

Knowledge Stream

Research and Development Office

FY 2017 Research Review





Research and Development Office Contact Information

Levi Brekke
Chief
303-445-2494
lbrekke@usbr.gov

John Whittler
Science and Technology
Program Coordinator
303-445-2241
jwhittler@usbr.gov

Yuliana Porras-Mendoza
Advanced Water Treatment Research
Coordinator and Desalination and
Water Purification Research Program
Manager
303-445-2265
yporrasmendoza@usbr.gov

Erin Foraker
Renewable Energy and Infrastructure
Research Coordinator
303-445-3635
eforaker@usbr.gov

Ken Nowak
Water Availability Research
Coordinator
303-445-2197
knowak@usbr.gov

Samantha Zhang
Technology Transfer Administrator
303-445-2126
szhang@usbr.gov

Ronda Dorsey
Programs Information Specialist
303-445-2624
rdorsey@usbr.gov

Rosann Velnich
Budget Analyst
303-445-2231
rvelnich@usbr.gov

Patricia Loetel
Administrative Assistant
303-445-2125
ploetel@usbr.gov

Message from the Chief

Hello and welcome to the "FY 17 Research Review" issue of the *Knowledge Stream*!

In this issue, the Research and Development (R&D) Office is pleased to highlight accomplishments toward addressing the many technical challenges facing Reclamation as it manages, develops, and protects water and related resources in an environmentally and economically sound manner. These accomplishments were the result of funding support from two R&D programs (Science and Technology (S&T) and Desalination and Water Purification Research Advanced Water Treatment (DWPR)), and through the many project-level collaborations involving Reclamation Regional and Denver Offices, other Federal agencies, and non-Federal organizations.

Example accomplishments you will learn about include:

- Implementing electro-osmotic pulse (EOP) technology to stop water leaks through concrete.
- Exploring the feasibility of using unmanned aerial aircraft systems (UAS) in managing rockfall hazard areas.
- Using synthetic sheet piles to improve canal safety.
- Optimizing hydraulic turbine operation and maintenance with cavitation detection technology.
- Improving power system safety with personal protective grounds (PPG).
- Developing a surrogate acoustic system to obtain continuous fluvial bedload measurements.
- Investigating effectiveness of Helix downstream fish passage design adaptations at various locations based on site-specific hydraulic criteria.
- Creating a new high quality catalog of landfalling atmospheric rivers to explore drivers of variability in seasonal total precipitation along the West Coast.

In addition, you will also learn about special topics in open water data with Reclamation's Water Information System (RWIS), continued investment in the detection and management of invasive mussels, and funding opportunities with the Coordinated Technology Implementation Program (CTIP). The issue also highlights other S&T Program advancements in Technology Transfer and Prize Competitions. Activity area coordinators and contacts are provided inside if you would like to follow-up and learn more about these activities. We hope you enjoy!

Levi Brekke
Chief, Research and Development

Subscribe to the *Knowledge Stream*:

research@usbr.gov

PO Box 25007
Denver Federal Center
Denver, Colorado 80225-0007
303-445-2125

Visit the R&D website at <https://www.usbr.gov/research/>



Contents



John Whitley, Reclamation's Science and Technology (S&T) Program Coordinator, served as Content Lead for this issue.

John manages S&T program goals, policies, and business practices by coordinating research selection and execution, innovating administration, supporting budget formulation, developing partnerships, and supporting technology transfer to move research into practice.

2 Message from the Chief

4 Program Highlights

Desalination & Water Purification Research Program
Science & Technology Program

8 Research Area Results

Water Infrastructure
Power and Energy
Environmental Issues for Water Delivery and Management
Water Operations and Planning
Developing Water Supplies

16 Special Topics

Open Water Data
Invasive Mussels
Coordinated Technology Implementation Program (CTIP)

21 Technology Transfer

22 Water Prize Competition Center

23 About the Knowledge Stream

Desalination & Water Purification Research Program

Program Highlights

Reclamation's Desalination and Water Purification Research Program (DWPR) is a nationwide competitive, merit-based program that funds research at three major levels: laboratory-scale, pilot-scale, and full-scale projects.

While the need for water for irrigated agriculture is greatest in the arid West, the need for high quality water for drinking and for industry is nationwide. The DWPR Program works with Reclamation researchers and partners to develop innovative, cost-effective, and technologically efficient ways to treat impaired waters to augment usable water supplies.

The program has aligned its objectives with the strategic desalination research agenda and the needs identified in the last two publications from the National Research Council of the National Academies, from 2008 and 2012, *Desalination: A National Perspective and Water Reuse: Potential for Expanding the Nation's Water Supply Through Reuse of Municipal Wastewater*, respectively.

Contact

Yuliana Porras-Mendoza
303-445-2265
yporrasmendoza@usbr.gov

More Information

DWPR Home
<https://www.usbr.gov/research/dwpr/index.html>

DWPR Research Projects
<https://www.usbr.gov/research/dwpr/reportpdfs.html>

DWPR helps Reclamation and its partners confront widening imbalances between supply and demand in basins throughout the Western United States through testing and development of new advanced water

treatment technologies. The DWPR Program focuses on three main goals: (1) augment the supply of usable water in the United States; (2) understand the environmental impacts of desalination and develop approaches to minimize these impacts relative to other water supply alternatives; (3) develop approaches to lower the financial costs of desalination so that it is an attractive option relative to other alternatives in locations where traditional sources of water are inadequate.

In FY 2017, Reclamation awarded \$3.62 million to conduct laboratory and pilot-scale desalination and water purification research in 13 states. Sixteen laboratory projects, four new pilot-scale projects and one continuing pilot-scale project were selected. The \$3.62 million in federal funding was matched by \$3.52 million in non-federal funds.

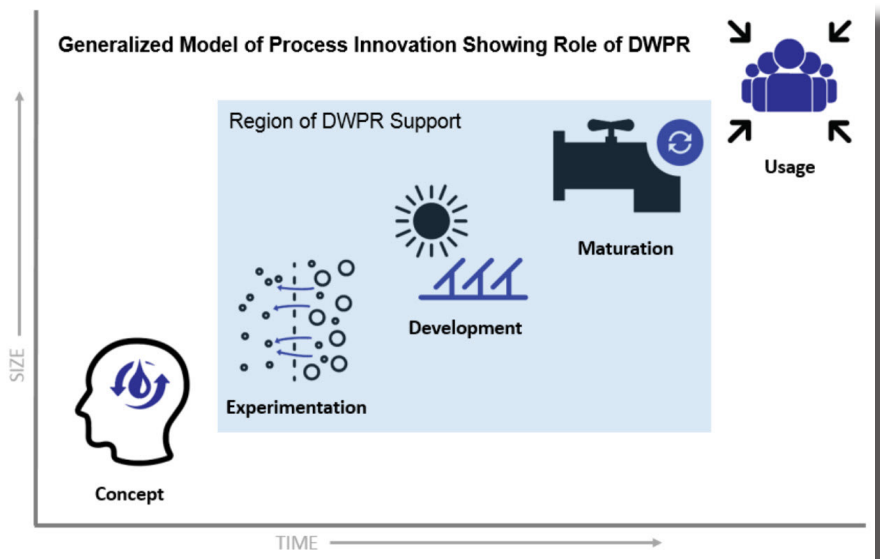

FY 2017 DWPR Laboratory-Scale Projects

<i>State</i>	<i>Organization</i>	<i>Reclamation Funding</i>	<i>Non-Federal Funding</i>
California	Orange County Water District	\$149,894	\$539,747
Connecticut	Yale University	\$150,000	\$39,236
	University of Connecticut	\$149,965	\$16,560
Florida	University of South Florida	\$150,000	\$0
Kansas	University of Kansas Center for Research, Inc.	\$54,802	\$54,802
Massachusetts	Massachusetts Institute of Technology	\$150,000	\$0
	Northeastern University	\$150,000	\$5,000
Nebraska	University of Nebraska, Lincoln	\$147,217	\$0
New Mexico	New Mexico Institute of Mining and Technology	\$148,704	\$73,242
New York	Research Foundation for the State University of New York	\$150,000	\$73,503
North Carolina	University of North Carolina	\$144,438	\$0
Oklahoma	University of Tulsa	\$144,396	\$0
Pennsylvania	Saint Francis University	\$133,519	\$0
	GreenBlu, LLC	\$149,994	\$149,998
Texas	Texas Tech University	\$144,696	\$0
Wyoming	University of Wyoming	\$148,880	\$0

FY 2017 DWPR Pilot-Scale Projects

<i>State</i>	<i>Organization</i>	<i>Reclamation Funding</i>	<i>Non-Federal Funding</i>
California	Orange County Water District	\$249,966	\$766,682
	Regents of the University of California, Los Angeles	\$299,062	\$300,000
Massachusetts	Massachusetts Institute of Technology	\$199,000	\$200,000
New Mexico	Regents of New Mexico State University	\$399,292	\$99,292

FY 2017 DWPR Second-Year Continuing Pilot-Scale Project from FY 2016

<i>State</i>	<i>Organization</i>	<i>Reclamation Funding</i>	<i>Non-Federal Funding</i>
California	Eastern Municipal Water District	\$200,000	\$1,876,688

Science & Technology Program

From Research to Impacts

The Science and Technology Program is working to advance Reclamation's technical abilities to manage, develop, and protect water and related resources in an environmentally and economically sound manner. The approach to support this activity is to address the full range of technical issues confronting Reclamation water and power managers and their project stakeholders through innovative development, applied, and demonstration research. The goals of the Science and Technology Program are:

1. Develop cost-effective solutions for the technical and scientific problems affecting accomplishment of Reclamation's mission, while leveraging funds with other research entities to advance research in a collaborative manner.
2. Build and strengthen scientific and engineering capacity for Reclamation in order to advance the most relevant research and demonstration projects for Reclamation.
3. Communicate those solutions to Reclamation offices, other water and power management officials, and the general public in order to build partnerships with other water and power management agencies and stakeholders.

Contact

John Whitler
303-445-2241
jwhitler@usbr.gov

More Information

FY 2017 S&T Program
Impacts and Highlights
<https://www.usbr.gov/research/st/fy17brochure.pdf>

S&T Research Projects
<https://www.usbr.gov/research/projects/index.html>

S&T Research Bulletins
<https://www.usbr.gov/research/publications/updates.html>

S&T Home
<https://www.usbr.gov/research/st/index.html>

The S&T Program is working to tell a better story about completed and ongoing research projects with demonstrated or projected benefits to Reclamation. These research projects are having a direct impact on Reclamation's ability to meet core mission needs of water and power delivery.

For many of these projects it was possible to estimate a return on investment to the S&T Program and a benefit cost ratio. Some of the projects highlighted have yet to undergo an economic evaluation, but show significant impacts through the narrative description of impacts. Please review the FY17 S&T Program Impacts and Highlights (<https://www.usbr.gov/research/st/fy17brochure.pdf>) document to review many of the projects that are leading to a better, faster, cheaper Reclamation.

RECLAMATION *Managing Water in the West*



FY 2017 Impacts and Highlights

Science and Technology Program



S&T Science Priority Research Areas and Categories



Power and Energy

Hydro Powerplants, Energy Efficiency, Pumping Plants, and Non-Hydropower Renewable



Water Infrastructure

Dams, Canals, Pipelines and Miscellaneous Water Infrastructure



Environmental Issues for Water Delivery and Management

Water Delivery Reliability, Invasive Species, Water Quality, Sediment Management, and River Habitat Restoration



Water Operations and Planning

Water Supply and Streamflow Forecasting, Water Operations Models and Decision Support Systems, Open Data, and Climate Change and Variability

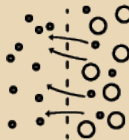

Developing Water Supplies

Advanced Water Treatment, Groundwater Supplies, Agricultural and Municipal Water Supplies, and System Water Losses

FY 2017 Program Stats

198 Projects

119 Lead Researchers

\$11.12M of Funding Utilized

\$11.56M Partner Cost Share (9 university, 11 local agencies, 3 tribes, 5 states, 12 federal agencies, 17 private for profit or non-profit partners)

Research Area Results



Water Infrastructure

Demonstration Project to Implement Electro-Osmotic Pulse (EOP) Technology to Stop Water Leaks through Concrete - ID 4553

Need and Response

Electro-osmotic pulse (EOP) was developed to control water seepage through concrete by reversing the movement of water, making it capable of drying-out concrete vaults and other high-head structures traditionally plagued with water ingress. After a year long test at Trinity Dam, a visual inspection observed the area was dry to the touch. EOP can decrease the amount of maintenance required by facilities where water is seeping through the walls or cracks cannot be grouted. In addition, this technology increases worker safety at facilities where water seepage and leaks cause corrosion of the ladders, ladder anchors, and other structure metalwork. EOP installation and operating costs are very low.

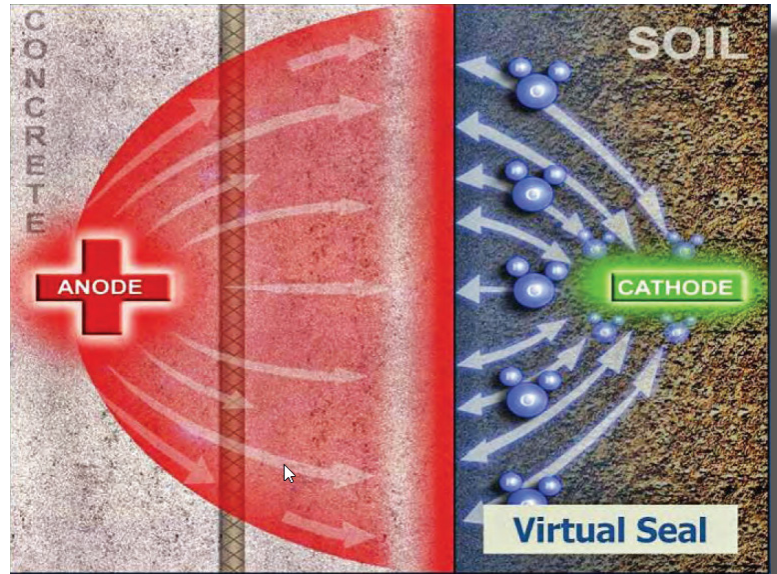

Contact

Erin Foraker
303-445-3635
eforaker@usbr.gov

Bobbi Jo Merten
303-445-3635
eforaker@usbr.gov

More Information

S&T Program Research
Project 4553
<https://www.usbr.gov/research/projects/detail.cfm?id=4553>

S&T Program Research
Project 7109
<https://www.usbr.gov/research/projects/detail.cfm?id=7109>

S&T Program Research
Project 1700
<https://www.usbr.gov/research/projects/detail.cfm?id=1700>

Partners

USACE-ERDC developed the technology and Trinity Dam supported the demonstration of the technology in a new application to expand the use of EOP beyond its original research objective.

ROI Information

S&T Investment \$168,000
Benefits \$267,000
Benefit-Cost Ratio 1.6

Impact

Water Delivery Benefit - Greater Infrastructure Longevity
Maintenance Benefit - Reduced Maintenance Costs
Other Benefit - Improved Worker Safety, Better Decision Making

Exploring the Feasibility of Using UAS in Managing Rockfall Hazard Areas - ID 7109

Need and Response

This project demonstrated the use of unmanned aircraft systems (UAS) to ensure safe and successful future UAS flights in support of rockfall mitigation at Hoover Dam. UAS rockfall inspections reduce dangerous rope access team activities and provides improved data, improved mitigation efforts, and better capability to compare data over time. This project will help the Bureau of Reclamation to plan and make better decisions regarding rockfall mitigation efforts by providing a process for obtaining and analyzing high quality, repeatable imagery and models of rockfall hazard areas through the use of UAS. In many cases, the largest benefit of UAS research is to have access to information that would otherwise be unavailable. This research will also demonstrate that using UAS to inspect penstocks, tunnels, siphons, and other inaccessible features could be cheaper and safer than traditional manned inspection techniques.

ROI Information

S&T Investment \$290,000

Benefits \$1,620,000

Benefit-Cost Ratio 5.6

Impact

Other Benefit - Improved Data Collection, Better Decision Making



Demonstration of Synthetic Sheet Piles to Improve Canal Safety - ID 1700

Need and Response

A field trial was conducted at the Truckee Canal in Fernley, Nevada, to evaluate the use of vinyl sheet piles to improve canal safety. Truckee Canal was selected for the field trial because a large amount of existing subsurface information was available to select a range of site conditions commonly encountered at other Reclamation canals. Synthetic sheet piles are being considered as a canal safety improvement measure to address embankment flaws (animal burrows, tree root systems, construction defects), which are often attributed to canal failures and incidents. The field trial demonstrated that vinyl sheet piles, which are half the cost and more corrosion resistant than traditional steel sheet pile, were an effective cut off wall alternative to improve canal safety. Information collected during this project will aid in the selection of viable canal sites for the use of vinyl sheet piles to improve canal safety at reduced costs.

Partners

The project would not have been possible without strong partnerships with the Lahontan Basin Area Office, Truckee Carson Irrigation District, and Crane Materials International, which provided nearly half of the project funding.

Impact

Water Delivery Benefit - Greater Infrastructure Longevity

Maintenance Benefit - Reduced Maintenance Costs

Other Benefit - Improved Worker Safety, Better Decision Making





Power and Energy

Cavitation Detection Technology for Optimizing Hydraulic Turbine Operation and Maintenance - ID 2944

Need and Response

Cavitation is an expensive problem for the hydroelectric power industry, causing damage to the turbine, costly repairs, lost generation, and decreased efficiency. Cavitation tests were performed at J.F. Carr, Flatiron, Flaming Gorge, Upper Molina, and Grand Coulee resulting in the development of new and reliable test techniques and instrumentation for cavitation detection, including a machine condition monitoring tool that allows plant operations better flexibility to avoid operating in cavitation producing conditions. These test results provide information that allows Reclamation to better understand operational cavitation zones and limitations. These benefits are derived from the ability to operate at higher capacities, reduce the frequency of new turbine runners being installed, and reduce outage time at the facility due to cavitation damages to the runners. This project also performed similar testing and analysis for four other facilities, and the methods and techniques developed can be applied at all 53 Reclamation powerplants as needed.



Contact

Erin Foraker
303-445-3635
eforaker@usbr.gov

More Information

S&T Program Research
Project 2944
<https://www.usbr.gov/research/projects/detail.cfm?id=2944>

S&T Program Research
Project 2910
<https://www.usbr.gov/research/projects/detail.cfm?id=2910>

S&T Program Research
Project 1711
<https://www.usbr.gov/research/projects/detail.cfm?id=1711>

S&T Program Research
Project 613
<https://www.usbr.gov/research/projects/detail.cfm?id=613>

ROI Information

S&T Investment \$335,000
Benefits \$5,730,000
Benefit-Cost Ratio 17.1

Impact

Power Generation Maintenance Benefit - Optimized and Improved Efficiency of Existing Hydropower Generation Machinery and Equipment
Maintenance Benefit - Reduced Maintenance Costs

Power System Diagnostics - Micro-Ammeter - ID 2910

Need and Response

The Direct-Current (DC) Micro-Ammeter efficiently locates defects and faults in generator stator windings. A stator winding fault is often very difficult to physically locate with the rotor in the machine. The new device decreases the length of time necessary to identify faults within generators from months to days, potentially reducing the forced outage time by several weeks or sometimes months. This technology was demonstrated at Buffalo Bill and Spring Creek and tested at Folsom, Palisades, and the Grand Coulee Left Powerplant. The methods and techniques developed can be applied at all 53 Reclamation powerplants.

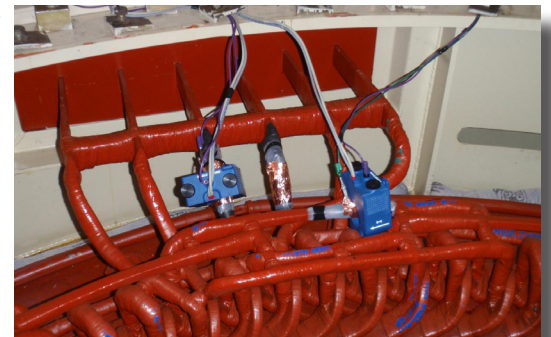

ROI Information

S&T Investment \$204,000
Benefits \$561,000
Benefit-Cost Ratio 2.8

Impact

Power Generation Maintenance Benefit - Optimized and Improved Efficiency of Existing Hydropower Generation Machinery and Equipment
Maintenance Benefit - Reduced Maintenance Costs

Feasibility of Rotor Installed Machine Corona Mapping with Patch Antennas - ID 1711

Need and Response

Currently, stator corona mapping is one of the most useful diagnostic measures of rotating machine health. However, because this test currently requires rotor removal to perform, it can rarely be accomplished. Moreover, rotor removal may require days or weeks of work for teams of personnel, and the test requires two technicians to enter the bore of an energized asset. In short, the current costs and risks associated with this important test are significant.

The technology and methods discussed in this project could potentially reduce, and in some cases completely eliminate costs and risks as the rotor would not have to be removed, and personnel would not have to physically enter the asset while it is energized. This research employs technology currently found in most smart phones and other consumer electronics, and shows its feasibility in corona mapping the stator windings of rotating machines.

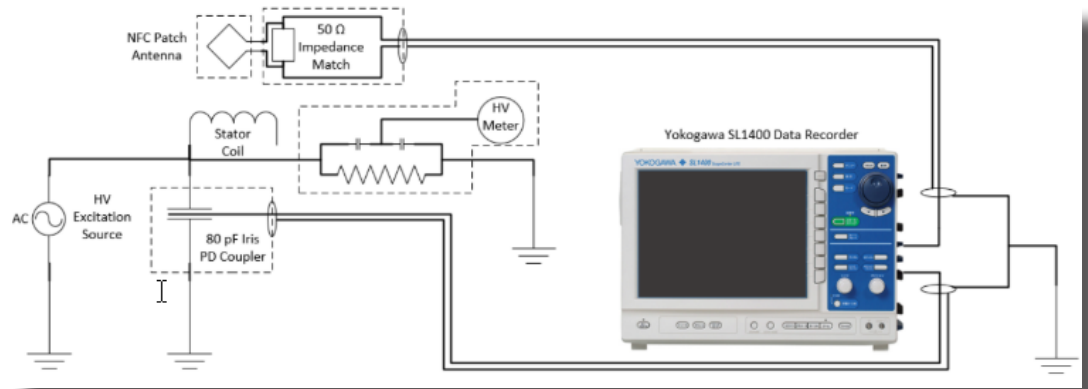

Impact

Power Generation Maintenance
Benefit - Optimized and Improved
Efficiency of Existing Hydropower Generation Machinery and Equipment
Maintenance Benefit - Reduced Maintenance Costs

Power System Safety - Personal Protective Grounds (PPG) - ID 613

Need and Response

This project improved the scientific understanding of grounds placement, configuration, and actual exposure voltages while working on high voltage machinery and transmission lines. The results reduce the potential for severe personal injuries and create a safer working environment. The research also supports avoided costs such as preventing arc flash events. A single arc flash event costs a minimum of \$750k, and typically costs over \$1M (Workplace Safety Awareness Council through a grant from Occupational Safety and Health Administration (OSHA)).

Partners

MP Region, UC Region, GP Region, PN Region, LC Region

ROI Information

S&T Investment \$864,000
Benefits \$1,000,000
Benefit-Cost Ratio 7.4

Impact

Power Generation Maintenance Benefit - Optimized and Improved Efficiency of Existing Hydropower Generation Machinery and Equipment
Maintenance Benefit - Reduced Maintenance Costs

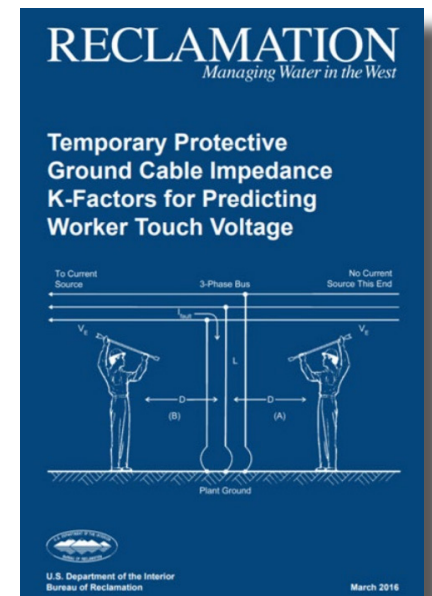



Environmental Issues for Water Delivery and Management

Helix Downstream Fish Passage Design - ID 3437

Need and Response

This project investigated whether the helix design developed for juvenile fish passage at Cle Elum Dam could be easily adapted to other locations based on site-specific hydraulic criteria. An innovative helix design for continuous downstream juvenile fish passage at Cle Elum Dam was modeled and designed in 2013 to 2015 with support from Reclamation's Columbia Cascades Area Office and the State of Washington.

The helix design allows for safe, volitional downstream fish passage at high-head dams (>100 ft) with large water surface fluctuations (>50 ft). Dams constructed without allowance for upstream and downstream fish passage have resulted in the extirpation of anadromous salmon and steelhead populations in many areas.

Providing access to high value spawning and rearing habitat that has been cut off due to the construction of dams is a key component for the recovery of threatened and endangered anadromous fish species. Successful adaptation of the Cle Elum Dam helix downstream fish passage system to other locations will provide another viable passage option, particularly for high-head dams with large water surface fluctuations.

Contact

Jennifer Bountry
303-445-3614
jbountry@usbr.gov

Impact

Other Benefit - Improved Data Collection, Better Decision Making

More Information

S&T Program Research
Project 3437
<https://www.usbr.gov/research/projects/detail.cfm?id=3437>

S&T Program Research
Project 137
<https://www.usbr.gov/research/projects/detail.cfm?id=137>

S&T Program Research
Project 2910
<https://www.usbr.gov/research/projects/detail.cfm?id=2910>

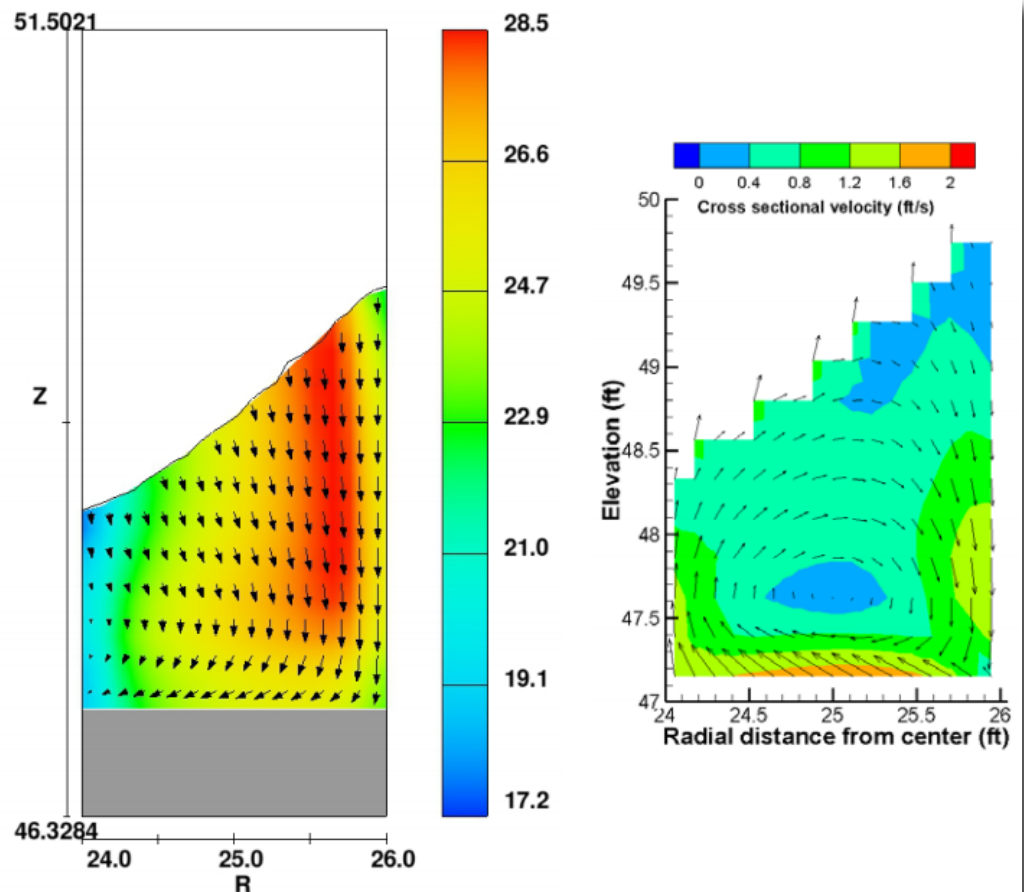

Development of Surrogate Acoustic System to Obtain Continuous Fluvial Bedload Measurements - ID 137

Need and Response

This is the only system of its kind in North America and perhaps the largest in the world. The Elwha Impact Plate System has been monitoring sediment during and after the removal of two large dams on the Elwha River. Continuous bed load is critical information that can inform reservoir sediment management and future dam removal efforts where sediment will not be mechanically removed but released downstream.

The benefits of this research include:

1. Safety - Bedload sediment typically moves only during flood events, when flow conditions are unsafe for direct measurement. This surrogate bedload measurement system provides the ability to continuously measure bedload while significantly reducing the risk to human safety;
2. Better Information - The continuous nature of the data provides information relative to the limited periodic measurements using classical means. Such information will improve the understanding of coarse bedload transport and insight to temporal patterns of bed load transport; and,
3. Improved decision-making - An increased understanding of bedload transport allows Reclamation engineers to better predict the impact of human actions in and around the nation's rivers. The coarsest fraction of fluvial sediment (typically transported as bed load) has the greatest influence on channel form.

Partners

University of Mississippi National Center for Physical Acoustics, USDA-ARS, USGS

Impact

Other Benefit - Improved Data Collection, Better Decision Making

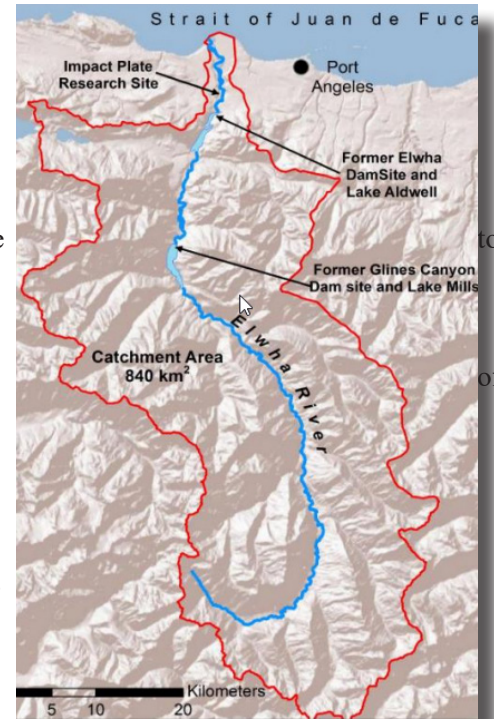

Ephemeral Tributary Sediment Transport Measurement - ID 2910

Need and Response

Acoustic methods can improve and expand the dataset associated with sediment movement in rivers used to inform engineering design and maintenance. This project builds on recent advances in surrogate research to expand application to ephemeral streams in the arid southwestern United States which run infrequently, but when they do, supply large amounts of sediment to the mainstream river. Due to the flashy nature (short-lived with a large peak) of ephemeral system runoff, measuring the volume of sediment delivery by standard methods is practically impossible. Acoustics can be used as a surrogate to provide data related to sediment transport (both suspended load and bed load) during flashy, monsoon-driven events in ephemeral basins.

Millions of dollars are spent annually on river maintenance activities on the Middle Rio Grande alone. Knowing the sediment budget of the river reach where a project is being planned is important for engineers who are tasked with design. Although engineers have been successful in the past, having a better estimate of the sediment budget for a reach should include sediment delivery from the upstream reach.

Impact

Other Benefit - Improved Data Collection, Better Decision Making



Developing Water Supplies

Literature Review and Sampling Plan Development for the San Juan River Quality Study - ID 1790

Need and Response

This study conducted a literature review focusing on water quality in the San Juan River watershed and collected data from previous efforts. The San Juan Lateral water treatment plant (SJL) is a component of the Navajo-Gallup Water Supply project, which will treat San Juan River water and deliver potable water. Knowledge gaps pertinent to the design and operation of the SJL water treatment plant were identified.

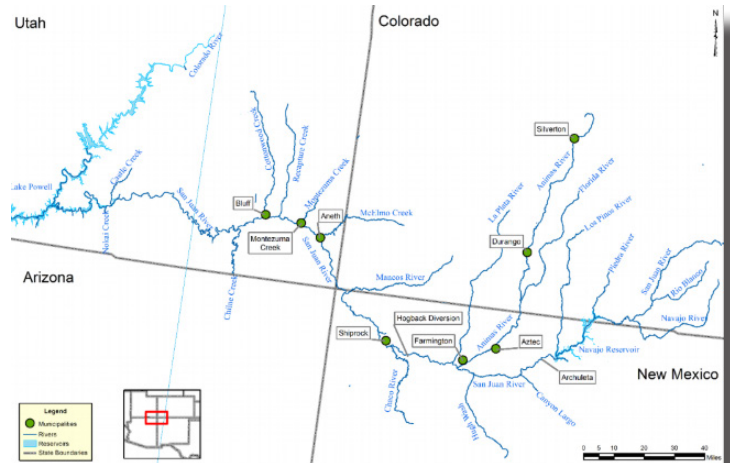

ROI Information

S&T Investment \$25,000
Benefits \$252,750
Benefit-Cost Ratio 10.1

Impact

Other Benefit - Improved Data Collection, Better Decision Making

Contact

Yuliana Porras-Mendoza
303-445-2265
yporrasmendoza@usbr.gov

More Information

S&T Program Research
Project 1790
<https://www.usbr.gov/research/projects/detail.cfm?id=1790>

S&T Program Research
Project 2922
<https://www.usbr.gov/research/projects/detail.cfm?id=2922>

City of Goodyear Wetlands Project - ID 2922

Need and Response

Reclamation's Science and Technology (S&T) program, Title XVI program, and the Lower Colorado Region Phoenix Area Office have been working with the City of Goodyear, Arizona, to develop a cost-effective and environmentally sensitive advanced water treatment alternative for managing inland reverse osmosis concentrate generated at the City of Goodyear's Bullard Water Campus.

Partners

New Mexico
Institute of
Mining and
Technology,
Ben-Gurion
University of

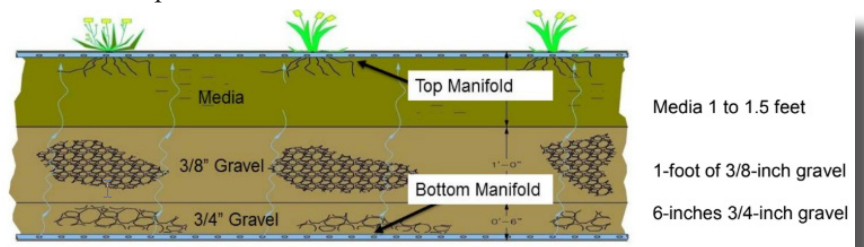

the Negev, United States Army Corps of Engineers, local landowners, and the United States Geological Survey. Project partners have funded nearly 80% of this research to date, and are expected to fund approximately 50% of future costs.

ROI Information

- S&T Investment \$1,020,000
- Benefits \$10,248,000
- Benefit-Cost Ratio 10.0

Impact

Water Delivery Benefit - Expanding Available Water Supplies
Other Benefit - Better Decision Making



Water Operations and Planning

Seasonal and Extended-range Predictability of Atmospheric Rivers and their Associated Precipitation - ID 1501

Need and Response

Atmospheric rivers (AR) are fast-moving ribbons of moisture-laden air that originate over the Pacific Ocean. Upon making landfall, typically on the west coast of North America, the result is often intense and persistent precipitation. As part of the record-breaking 2017 AR season, multiple strong, nearly back to back ARs in late January and early February produced record precipitation in parts of California. The precipitation and ensuing flooding created additional challenges for water managers.

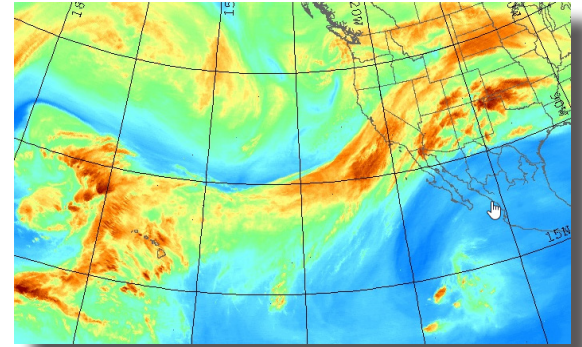

This project created a new high quality catalog of landfalling ARs from 1948 to present. The catalog is being used to explore drivers of variability in landfalling ARs and the contribution of ARs to seasonal total precipitation along the West Coast. Preliminary results from these investigations show promising insights regarding the prediction of ARs, specifically orientation at landfall, which greatly influences where precipitation will be most pronounced.

Contact

Ken Nowak
303-445-2197
knowak@usbr.gov

More Information

S&T Program Research
Project 1501
<https://www.usbr.gov/research/projects/detail.cfm?id=1501>

S&T Program Research
Project 1620
<https://www.usbr.gov/research/projects/detail.cfm?id=1620>

In parts of the West Coast of the United States, up to 60% of total annual precipitation can be delivered by atmospheric rivers. Accordingly, a weak AR season can be a significant detriment to annual water supply. Conversely, a strong AR event or multiple ARs, in close proximity, can create notable flooding, as was experienced by parts of California in early 2017. This highlights that improved AR forecasting, from seasonal outlooks, to individual events is of great value to water managers.

Impact

Other Benefit - Improved Data Collection, Better Decision Making

Development of an Ensemble National-Domain Dataset of Gridded Meteorological Fields - ID 1620

Need and Response

This project developed a new dataset of historical gridded meteorological data (temperature and precipitation) for use in studies supporting water management. Historical meteorological data are used in a variety of water management related applications, such as calibration of hydrologic models and hydrologic hazard assessments. If historical meteorological estimates deviate even modestly from “truth,” this can impact model calibration, thereby perpetuating error into future applications of that model configuration. For example, a hydrology model calibrated based on an under-estimation of historical precipitation will be producing observed streamflow based on less precipitation than actually occurred. For some input precipitation, the model will generate more streamflow than is likely to be realized, which could have serious implications for both long-term planning and real-time operations. An ensemble of historical meteorological forcing data enables more robust calibration to reduce the likelihood of such issues.

Impact

Water Delivery Benefit - Reduce Risk of Water Delivery Interruptions, Increase Potential for More Water Deliveries

Special Topic: Open Water Data

Reclamation Water Information System (RWIS)

Need and Response

RWIS is an open data pilot in which select water data are aggregated from Reclamation's five regions to a single, publicly accessible web-based data portal. Previously, Reclamation had no central repository for water-related data and no agency-wide public-facing location for sharing water-related data. The RWIS team worked with regional and Denver staff to make available select Reclamation reservoir, river, and related hydrologic data in human and machine-readable formats, downloadable and accessible via a map interface, data query, and web services. RWIS serves as a foundation to serve more data to the public and within Reclamation.

Since launching less than a year ago, the RWIS system is currently serving approximately 683 data requests per month. The cost to manually fulfill such a data request rate is estimated to be \$1.6M/year. Accordingly, over the next ten years, RWIS is expected to provide over \$10M in avoided costs (economic benefits), compared to the approximately \$1M S&T investment in the current version of the system.

Contact

Ken Nowak
303-445-2197
knowak@usbr.gov

More Information

S&T Program Research
Project 1627
<https://www.usbr.gov/research/projects/detail.cfm?id=1627>

Reclamation Water
Information System
<https://water.usbr.gov>

Team Contact
rwis@usbr.gov

Reclamation Supports the Open Water Data Initiative

Open data generally provides enhanced Federal transparency and accountability, encourages civic engagement in resource issues, enables innovation in accomplishing an agency's mission, and supports economic development and entrepreneurship through the mobilization of data. Furthermore, the RWIS pilot provides specific benefits associated with making Reclamation water data open (see below).

Partners

MP Region, UC Region, GP Region, PN Region, LC Region

ROI Information

S&T Investment \$1,020,000
Benefits \$10,200,000
Benefit-Cost Ratio 10.1

Impact

Other Benefits - Better Decision Making

1. More informed decision making by Reclamation, its partners, and other organizations by providing efficient and timely access to data;
2. Reduced costs by decreasing staff time required to fulfill data requests through the development of a standard data-sharing framework;
3. Improved efficiency in data access for external partners, the public, and the educational community;
4. Minimized duplication of efforts by providing a Reclamation-wide forum; and
5. Making access to Reclamation data more consistent with standards of other Interior, Federal, state and local entities.

RWIS provides historical and current data in easy-to-port, consistent, automated formats that a variety of stakeholders may use. Users can incorporate the machine-readable data from RWIS into apps and models to help plan operations, droughts, floods, and more!

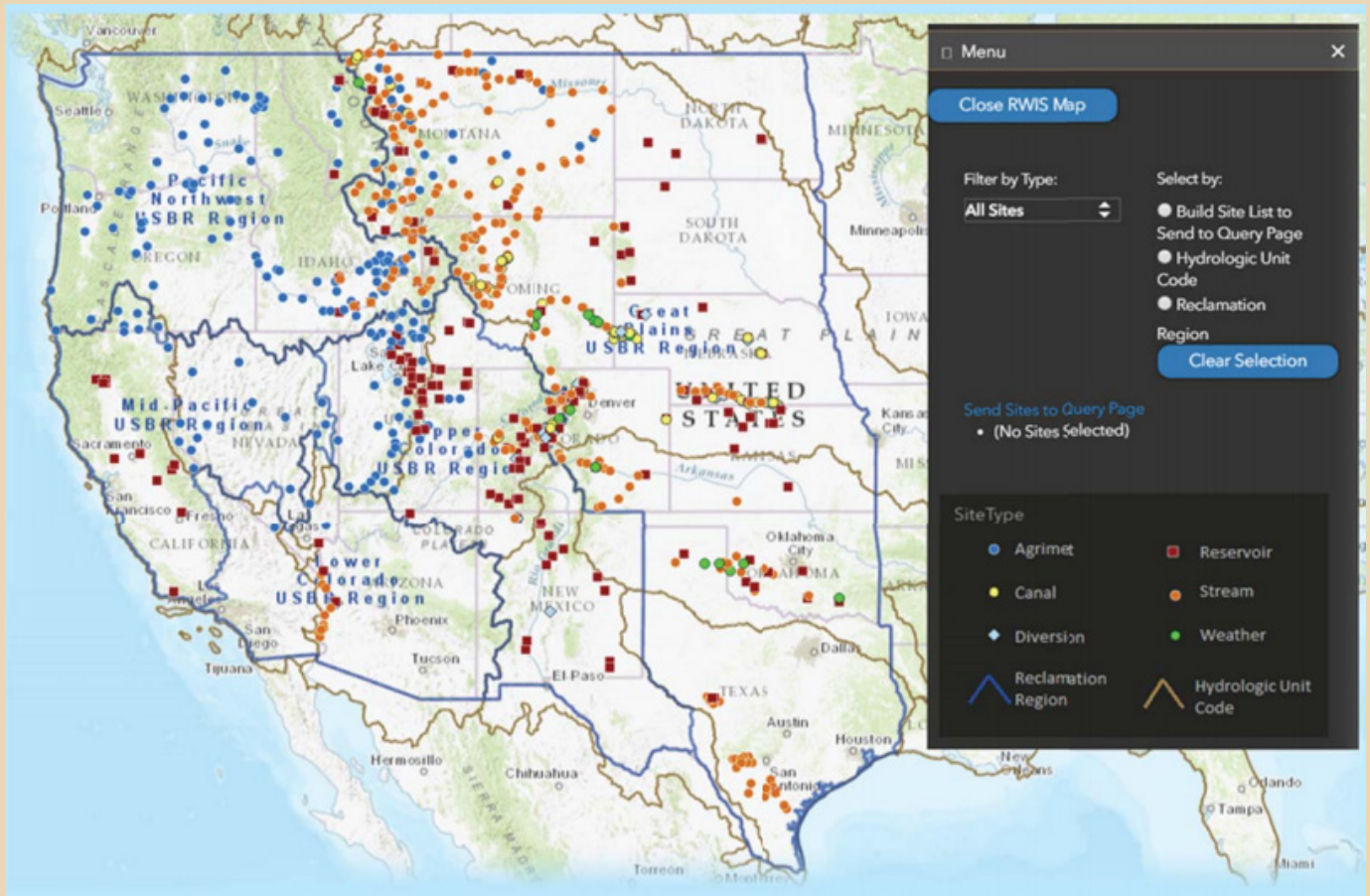

What can be done with RWIS?

- Incorporate real-time streamflow and reservoir levels/flow to see detailed picture of local conditions.
- Use SCADA system and RWIS to monitor operations and flow
- Analyze infrastructure and operations for strengths and weaknesses to withstand flood conditions.
- Track floods, droughts and other emergencies for real-time responses and compare historical and current information to determine patterns.
- Monitor water quality, habitat conditions, and other parameters over time.

Special Topic: Invasive Mussels

S&T Program Continues Research Investment for Zebra and Quagga Mussels

Reclamation's Science and Technology Program is providing funding support for research and development to detect and control invasive mussels throughout Reclamation. This research is developing, evaluating, and demonstrating effective technologies for the detection, prevention, control and management of invasive mussels both in the lab and in a field setting.

Significant progress was made in the last five years on detection methodologies and laboratory capabilities. Additionally, closed-pipe control technologies, specifically ultra-violet light (UV) systems, have proven effective. Research is ongoing and will address these priorities:

1. Continued improvements in early detection and monitoring methods;
2. Demonstration and evaluation of conventional and promising new open water control technologies;
3. Identification and development of effective long-term biological and engineering solutions;
4. Distribution and sharing of information on best practices for dealing with infestations.

Contact

Sherri Pucherelli
303-445-2015
spucherelli@usbr.gov

More Information

S&T Program Research
Project 1712
<https://www.usbr.gov/research/projects/detail.cfm?id=1712>

Reclamation's Zebra and
Quagga Mussels Main
<https://www.usbr.gov/mussels/>

Ultraviolet Light Treatment for Invasive Mussel Biofouling in Hydropower Generator Cooling Systems - ID 1712

Need and Response

Ultraviolet light (UV) treatment for reduction of invasive mussel biofouling in generator cooling systems was studied at hydropower facilities located along the lower Colorado River over eight years. Ultra violet light treatment was found to significantly reduce harmful invasive mussel settlement. This research was the impetus for full scale implementation of UV treatment at two powerplants in the Lower Colorado Region. Since full scale implementation at Parker Dam, operators have noticed a significant reduction in cooler overheating and maintenance.

In 2017, no coolers were impacted by mussel settlement. The treatment also has the potential to reduce the risk of unplanned outages at certain facilities. Parker Dam only experienced one unplanned outage as a result of mussel fouling, while Davis Dam experienced approximately 12, and UV treatment may help to mitigate this issue. The findings of this research have the potential to benefit a variety of Reclamation and non-Reclamation facilities in the future.



FY 18 Active S&T Mussel Projects

- Open Access Web-based Database of Invasive Aquatic Research and Water Quality Data - RDLES
- Alternate Control Strategy for Dreissinids Using Carbon Dioxide
- Sequencing of the Quagga Mussel Genome as a Tool for Biocontrol
- Molecular Methods for the Reclamation Detection Laboratory for Exotic Species (RDLES)
- Economic Evaluation of Activities Associated with Invasive Mussel Management
- Self-Cleaning Strainers and Filtration to Mitigate Mussel Impacts
- Hydraulically Driven Grinders to Mitigate Mussel Shell Debris
- Development of Methods for the Spectrophotometric Analysis of Water Supplies
- Underwater Imaging for Intake Trashracks at Glen Canyon to Assess of Mussel-Related Impacts
- Comparison of Next-generation DNA Sequencing to Traditional Morphological Identification for Environmental Monitoring
- Invasive Mussel Veliger Morphology
- Literature Review and Synthesis of Invasive Mussel Control Techniques
- San Justo Mussel Eradication
- Biologic Control Tests for Mussel Control
- Effective and Safe Decontamination for Underwater Inspection Equipment Exposed to Quagga and Zebra Mussels
- Continuation of Field Research on Advanced Coatings for Mussel Control
- Impact of UV Treatment on Hydroid Biofouling in Generator Cooling Pipes at Parker Dam
- Ranking and Categorizing Aquatic Invasive Species Threatening Western US Waters

Partners

The primary research partners were the Lower Colorado Dam's Office (LCDO) and RNT Consulting INC. Research partners provided approximately \$992,500 of in-kind labor and equipment to accomplish this research.

ROI Information

S&T Investment \$1,020,000

Benefits \$10,200,000

Benefit-Cost Ratio 10.1

Impact

Other Benefits - Better Decision Making

1. More informed decision making by Reclamation, its partners, and other organizations by providing efficient and timely access to data;
2. Reduced costs by decreasing staff time required to fulfill data requests through the development of a standard data-sharing framework;
3. Improved efficiency in data access for external partners, the public, and the educational community;
4. Minimized duplication of efforts by providing a Reclamation-wide forum; and
5. Making access to Reclamation data more consistent with standards of other Interior, Federal, state and local entities.

Special Topic: Coordinated Technology Implementation Program (CTIP)

Cooperative Technology Deployment and Sharing Program

The Coordinated Technology Implementation Program (CTIP) is a program funded by Federal Highway Administration (FHWA) that provides \$1.5 million annually to Federal



Contact

Dan Staton
Transportation Program
Manager
303-445-3858
staton@usbr.gov

More Information

Coordinated Technology
Implementation Program
<http://www.ctiponline.org>

agencies and tribes to help implement new technologies for Transportation assets such as roads, bridges, trails, and others. The program does not fund research, but rather looks for existing solutions that have already been developed. CTIP helps to implement new technologies that are not yet widely used.

CTIP is problem statement based meaning they are asking for applicants to completely define a problem versus providing solutions to the problem. If you have a Transportation asset related problem, be on the lookout for the Fiscal Year 2019 CTIP Problem Statement request. The request will typically come out in November with a due date in January. Reclamation owns 2,600 miles of road, over 1,700 bridges, 1,300 miles of trails, 450 boat ramps, and many more transportation related assets. Some potential Reclamation Transportation asset related problems include:

- Developing design standards for bridge railing on low volume roads with wide farm machinery.
- Re-coating steel bridges with difficult to access members.
- Loss of roadway width due to wave action.
- Expanding Unmanned Aerial Systems (UAS) use for transportation assets
- RFID technologies for low cost monitoring.
- Ultra High Performance Concrete for bridge decks.
- Bridge expansion joint repairs.
- Deep patch embankment repair with geosynthetics.
- Tracking visitor use using cell phone counts.
- Carbon Fiber Reinforced Plastic bridge repair.

Technology Transfer

Intellectual Property Protection and Effective Information Dissemination

During FY18, 35 technology transfer activities were supported. This included five active Cooperative Research and Development Agreements (CRADA), 14 active Material Transfer Agreements (MTA), 12 Patents, and four Licenses.

Evaluate Cavitation Damage and Turbine Runner Replacement Costs for Hydropower Plants

Reclamation has entered into CRADA with Alstom General Electric (Alstom) to evaluate cavitation, rough zone, and fatigue work at one of Reclamation's Power Plants. Turbine runner cavitation-erosion, excessive vibrations, and fatigue to the hydropower turbines are complex issues and add costs to the hydropower industry and its consumers. Developing new technologies and methods to detect and evaluate cavitation will provide Reclamation and other hydropower operators with better decision tools on condition, operations, and when to take a machine out of service for repairs. If this research is proven effective, it will increase efficiency and reduce operation and maintenance costs on Reclamation's hydropower fleet and help improve hydropower generation worldwide.

Testing New Technologies for Hydropower Generation Applications

Reclamation entered into MTAs to receive and test power generation equipment including digital excitation controllers, digital power system stabilizers, and three phase power bridges. These systems were developed by U.S. hydropower manufacturers including Andritz Hydro, L&S Electric, Inc., and Schneider Electric Systems Inc. Under the MTAs, Reclamation conducted tests, to determine their suitability for hydropower generation applications and provides each manufacturer with a report stating the tests that were performed, and whether or not the tests passed or failed.

MTAs allowed hydropower manufacturers to gain insights on the feasibility and requirements to manufacture and market their products to the global hydropower generation community. They also gained access to Reclamation's technical expertise and laboratory facilities, not readily available in the private sector, that are able to test and evaluate technologies for hydropower applications.

Evaluate Performance of Hydrokinetic Energy to Canal Operation and Infrastructure

Reclamation and the City and County of Denver Water (Denver Water) entered into a CRADA to evaluate hydrokinetic energy (HK) performance and impacts to canal operation and infrastructure. HK energy is a fairly new renewable energy resource that obtains energy from moving water in open channel systems. Reclamation has over 1,600 miles of canals and is interested in understanding this resource and its impacts on existing canal operation and infrastructure.

A pilot field demonstration is conducted with Denver Water installing HK turbines in one of their canals. If the proposed HK technology proves effective with minimal impacts to canal systems, then it will provide another potential source of renewable energy for canal owners including Reclamation. The CRADA combines the research expertise, test equipment and facilities, and Denver Water's background intellectual property in an effort to accelerate achieving the research objectives of the CRADA.

Contact

Samantha Zhang
303-445-2126
szhang@usbr.gov

More Information

Technology Transfer Main
https://www.usbr.gov/research/technology_transfer/index.html

Available Technologies
https://www.usbr.gov/research/technology_transfer/technologies.html

Water Prize Competition Center

Reclamation's Prize Challenges

Prize competitions are a unique tool for accelerating research to address elusive mission and operations challenges through private sector and “citizen solvers.” By tapping into a wealth of knowledge through on-line crowdsourcing techniques, prize competitions help Federal agencies advance research and development, drive innovation and generate a wealth of technical ideas and theoretical concepts in a cost effective manner for complex research issues that traditional R&D has not impacted or made significant progress.

Reclamation categorizes its prize competitions research needs into three main Theme Areas: Water Availability, Infrastructure Sustainability, and Environmental Compliance. The benefit gained by Reclamation is estimated to be between \$15,000 and \$30,000 per solution received, with the total value of solutions obtained from prize competitions to date as \$7.2 million.

Prizes also have non-monetary benefits, including:

- synergy building around ideas between researchers brought together from various disciplines and organizations;
- improved identification of the mission or operational problem and research need; and
- creation of communities of practice around a given problem.



Water Availability Theme Area **Sub-Seasonal Forecast Rodeo**

Improving sub-seasonal forecasts of temperature and precipitation (lead-times ranging from 15 to 45 days and beyond) would allow water managers to better prepare for shifts in hydrologic regimes, such as the onset of drought or occurrence of wet weather extremes. This competition involved solvers submitting forecasts of temperature and precipitation for 1 year, competing in real-time against other teams as well as official forecasts from the National Oceanic and Atmospheric Administration (NOAA).

Prize Competition Team Lead: Kenneth Nowak | knowak@usbr.gov
Learn more at: <https://www.usbr.gov/research/challenges/forecastrodeo.html>

Infrastructure Sustainability Theme Area **Long-Term Corrosion Protection of Existing Hydraulic Steel Structures**

Steel structures corrode, or degrade, without a properly applied corrosion control method. This degradation is typically identified by localized or general thinning of material, which reduces the structure's ability to support load, carry water, etc. Failure of hydraulic steel structures can cause extensive downtime, loss of productivity, property damage, and even loss of life. This competition sought new long-term solutions to protect steel structures in water immersion service to reduce the high cost incurred to keep steel infrastructure reliable and functional.

Prize Competition Team Lead: Bobbi Jo Merten | bmerten@usbr.gov
Learn more at: <https://www.usbr.gov/research/challenges/corrosion.html>



Contact

Ronda Dorsey
Prize Competition
Program Administrator, Acting
303-445-2624
rdorsey@usbr.gov

More Information

Water Prize Competition Center
<https://www.usbr.gov/research/challenges/index.html>

About the Knowledge Stream

The *Knowledge Stream*, published by the Bureau of Reclamation's Research and Development Office, is a seasonal magazine bringing mission-critical news about the agency's research and science, as well as the many challenges associated with managing water and generating power in the West, including: projects, tools, methods, practices, results, innovation, prize competitions, publications, and more.

Regional Science and Technology Coordinators Contact Information

Whether you are a regional researcher, Reclamation partner or customer, or just have an idea for a project that can help your region, the Regional Science and Technology Coordinators can help you with your research ideas, proposals, and projects.

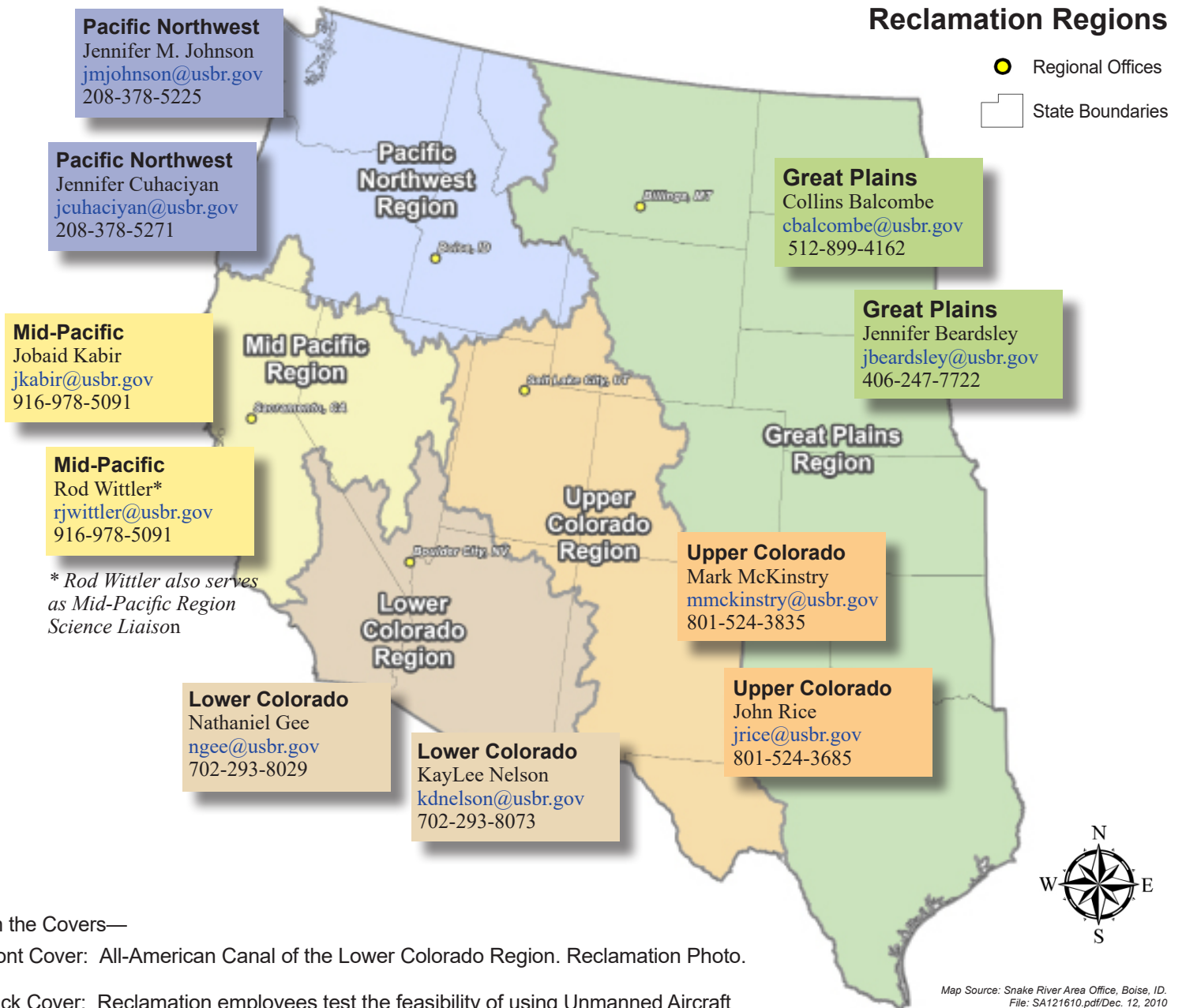

On the Covers—

Front Cover: All-American Canal of the Lower Colorado Region. Reclamation Photo.

Back Cover: Reclamation employees test the feasibility of using Unmanned Aircraft Systems (UAS) in managing rockfall hazard areas, such as at Hoover Dam. Reclamation photo. See S&T Project 7109 on p. 9 to learn more.

Map Source: Snake River Area Office, Boise, ID.
File: SA121610.pdf/Dec. 12, 2010

