

# **New Technology for Preventing Residential Electrical Fires: Arc-Fault Circuit Interrupters (AFCIs)**

By  
Douglas A. Lee\*  
Andrew M. Trotta\*  
William H. King, Jr.\*

Abstract - A new generation of residential electrical branch circuit breakers that incorporates technology to detect and mitigate the effects of arcing faults is described. Fire loss estimates attributed to electrical wiring and the development of the arc-fault circuit interrupter for the prevention of residential electrical fires are discussed. The industry voluntary standard for arc-fault circuit interrupters as well as the 1999 *National Electrical Code* requirement are reviewed.

## **INTRODUCTION**

Annually, over 40,000 fires are attributed to home electrical distribution systems. These fires result in more than 300 deaths and over 1,400 injuries each year. Statistics from 1992-1996 show level trends in each of these estimates with no indications of decline. In 1996, \$680 million in property loss was attributed to home electrical distribution fires.<sup>1</sup>

Arcing faults are one of the major causes of electrical wiring fires.<sup>2</sup> A 1994 insurance company survey of 660 electrical fires indicated that over 33% of these fires were from arcing conditions.<sup>3</sup> This data is further supported in a report by Smith and McCoskrie<sup>4</sup> that summarized the characteristics of 149 investigated residential fires.

Many of the investigations revealed failure modes characteristic of unwanted arcing.

When unwanted arcing occurs, it generates high temperatures and discharges molten metal that can ignite nearby combustibles such as paper, insulation, vapors, and some carpets.

The temperature of an arc can be several thousand degrees Celsius depending on the available current, voltage, and materials involved.<sup>5, 6, 7</sup>

Typically, a circuit breaker or other circuit protection device (e.g. fuse) is used to protect electrical branch circuit wiring, and reduce the risk of fire from overheating of installed wiring due to overloads or faults. The role of the circuit protection device is to interrupt the current before the heat generated by an overload or fault damages the wire's electrical insulation and/or reaches temperatures that could result in a risk of fire. An overload is a condition in which the current drawn by the sum of the electrical loads (appliances), which are connected to a particular circuit, exceeds the current capacity (ampacity) of the circuit conductors.

There are different types of electrical faults. One example is a short circuit, in which circuit conductors of opposite polarity contact each other, resulting in an immediate increase in current. Another type is a ground fault in which an ungrounded line conductor is faulted to a metal enclosure or other grounding conductor.

### **The Evolution of Circuit Protection Devices**

Circuit protection devices have evolved in capability and function from the time that fuses were introduced in the late 1800s, to the introduction of circuit breakers in the 1920s, to today with the introduction of arc-fault circuit interrupters (AFCIs). These

changes evolved both for convenience and to provide enhanced protection for electrical wiring systems.

Fuses were the first overcurrent protection devices used in residential electrical systems. A fuse interrupts current when an internal metal element melts if the current exceeds its rated capacity for a specified length of time. Fuses are designed with characteristics to match the application. A fast-acting fuse opens quicker than a slow-blow fuse, which has a greater thermal inertia to allow short-term overloads that may occur as a consequence of a normal load change. Examples are incandescent lights and refrigerator compressors, which draw initial currents that are several times higher than their steady state levels. Despite the simplicity and reliability of fuses, there are several disadvantages that have diminished their use in residential distribution systems. Fuses without a replaceable link need to be replaced after being blown. Early fuses were the same physical size for several current ratings, so a 20-ampere fuse could be inserted where a 15-ampere fuse was required. Because it is necessary to keep replacement fuses on-hand, some users would bypass the fuse completely if opened often or they ran out of replacements. Either of these could lead to dangerous overheating.

In the 1920s, Westinghouse Corporation invented the circuit breaker,<sup>8</sup> an electromechanical overcurrent protection device that can be reset after it interrupts an overcurrent condition. Upon detection of an overload or fault, an internal latch is released, and the contacts are driven apart by a spring. A circuit breaker uses two different mechanisms to detect an overcurrent condition that will cause it to trip and interrupt the current. The magnetic or instantaneous trip reacts to rapid increases in

current with a magnitude of at least 8 to 12 times the rating of the circuit breaker. This is intended to remove short circuits rapidly. The other mechanism is a thermal trip, which uses a bimetal strip that heats up when the current exceeds the rating. As it heats, the thermal strip bends and unlatches the contacts. The response of the element relies on the product of the square of the current and the time ( $I^2t$ ). Conventional circuit breakers address many of the disadvantages related to fuses; however, they may be considered less reliable since their operation relies on the action of several mechanical parts and the flow of high currents to activate them.

As part of the U.S. Consumer Product Safety Commission's (CPSC's) 1994 and 1995 efforts to reduce residential electrical system fires, the CPSC sponsored work on detecting and monitoring conditions that could lead to or cause fires in homes. The work was performed by Underwriters Laboratories Inc. (UL) and was documented in a report entitled, "Technology for Detecting and Monitoring Conditions that Could Cause Electrical Wiring System Fires." The study uncovered several possible technologies and concluded that arc-fault detection combined with ground-fault protection was the most promising technology to reduce the risk of fire when combined with conventional circuit breakers.<sup>9</sup> At that time, such an arc-fault circuit breaker did not exist as a commercial device. Additional research<sup>10</sup> has led to the development of the AFCI as a commercial product.

AFCIs are circuit protection devices designed to protect against fires caused by arcing faults in electrical wiring. An AFCI is formally defined as "a device intended to provide protection from the effects of arc faults by recognizing characteristics unique to

arcing and by functioning to de-energize the circuit when an arc-fault is detected.”<sup>11</sup> It is important to note that AFCIs may mitigate the effects of arcing faults but cannot eliminate them. In some cases, the initial arc may cause ignition prior to detection and circuit interruption by the AFCI.

## **ARCING**

Technically, an arc is defined as “a continuous luminous discharge of electricity across an insulating medium, usually accompanied by the partial volatilization of the electrodes”.<sup>12</sup> Some arcs are a normal consequence of device operation, such as opening a light switch or commutation from a motor. These devices are designed to contain arcs from combustible surroundings. However, other arcs are unwanted and may occur as a result of damaged or deteriorated wires and cords. For arcs in electrical distribution systems, the insulating medium is an air gap (for parting arcs), wire insulation, or any other insulator used to separate the electrodes or line and neutral conductors. An arc will not jump an air gap and sustain itself unless there is at least 350 V<sup>7</sup> across the gap. Therefore, in 120/240 Vac systems, it is difficult for arcing to cause ignition unless arc tracking occurs, or the electrodes loosely contact each other causing a sustained arcing fault.<sup>5</sup>

### **How Arcing Faults Develop**

There are two basic types of arcing faults – series and parallel. Series arcing faults occur when the current-carrying path in series with the load is unintentionally broken.

Arcing may occur across the broken gap and create localized heating. The magnitude of the current in a series arc is limited by the load. The series arcing currents are typically well below the typical circuit breaker's ampacity rating (often referred to as handle rating) and, therefore, would never trip the conventional circuit breaker either thermally or magnetically. Series arcing can lead to overheating that can be hazardous. Examples of conditions that may result in series arcing faults include loose connections to a receptacle or a wire splice, a worn conductor from over flexing of a cable, or a pinched cable in which the conductor has been severed.

A parallel arcing fault occurs when there is an unintentional conducting path between conductors of opposite polarity. Parallel arcing is only limited by the available fault current of the source and the impedance of the fault. If the fault is of low impedance, then the overcurrent device should open. However, when the fault impedance is relatively high, there may be insufficient energy to open the overcurrent device. This can cause arcing that can propel particles of molten metal onto nearby combustibles. A short circuit caused by an intermittent contact is one type of parallel arcing fault that can create hazardous arcs. A line-to-ground arcing fault is another form of parallel arcing fault and occurs when an ungrounded line conductor is faulted to a metal enclosure or other metal structure in contact with a grounding conductor. Examples of these are cords cut by furniture with a metal leg or loose wires that contact a grounded surface.

Parallel arcing faults are known to develop in three stages: leakage, tracking, and arcing.<sup>13</sup> Leakage currents normally occur in every electrical wiring system due to parasitic capacitance and resistance of the cable insulation. Leakage current values below 0.5 mA

are considered safe.<sup>14</sup> If the wiring is maintained in good condition, the wiring may be used safely for several decades.<sup>15</sup> However, when the wiring is subjected to moisture, conductive dusts, salts, sunlight, excessive heat, or high-voltage lightning strikes, the insulation can break down and conduct higher leakage currents.<sup>7</sup> As leakage current increases – undetected across the conduction path – the surface can heat up and pyrolyze the insulation. This process, known as tracking, produces carbon that generates more heat and progressively more carbon.<sup>16</sup> Although this process may continue for weeks, months, or longer without incident, eventually, sustained arcing may occur.

Parallel arcing faults are generally considered more hazardous than series arcing faults, since there is more energy associated with a parallel arcing fault than a series arcing fault. Parallel arcing faults usually result in peak currents above the handle rating of the conventional circuit breaker. This may trip the circuit breaker magnetically, if the impedance of the fault is low and the available fault current is sufficient. However, in many instances, the available short-circuit (fault) current is not sufficient to trip the circuit breaker instantaneously (magnetic trip). In addition, in many instances, the fault may be intermittent, so the overcurrent will not be sustained long enough to trip the conventional circuit breaker thermally.

## **MITIGATING THE EFFECTS OF ARCING**

Conventional circuit breakers are designed to protect the branch circuit wiring. The thermal settings are selected to prevent overloading of the circuit, while the instantaneous trip is intended for rapid removal of short circuits. Typically, instantaneous

tripping levels for 15 ampere (A) and 20 A residential circuit breakers are set way above 120 A rms (between 140 to 225 A rms) to avoid nuisance tripping from appliance inrush currents. The *Standard for Molded-Case Circuit Breakers, Molded-Case Switches, and Circuit-Breaker*, UL 489,<sup>17</sup> requires that 15 A and 20 A circuit breakers trip thermally in 2 minutes with a load current of 200 percent of the handle rating and in 1 hour with a 135 percent load current. This means that a 15 A circuit breaker can have a 30 A load for 2 minutes or a 20.25 A load for 1 hour before tripping. There are no calibration requirements for instantaneous tripping for conventional circuit breakers in UL 489.

### **Lowering the Instantaneous Trip Level of Circuit Breakers**

A 1992 study<sup>18</sup> sponsored by the Electronic Industries Association (EIA) was conducted by UL to determine if the instantaneous trip level of conventional circuit breakers could be significantly reduced. The purpose of reducing the instantaneous threshold was to mitigate the effects of arcing faults in extension and power cords used with appliances in residences. Tests were conducted on 1,590 receptacles in 80 residences to determine the available short-circuit current in 15 A and 20 A receptacles. Plot A in Figure 1 is a distribution of the estimated short-circuit current available versus the percentage of circuits having sufficient fault current to trip a breaker. Plot B in Figure 1 is the short-circuit current with 6 feet of No. 18 AWG appliance cord plugged into the receptacle being tested. The average available short-circuit current in surveyed residences at receptacles in 15 A branch circuits was 300 A. The average available short-circuit current at receptacles in 20 A branch circuits was 467 A.



Figure 1 shows that 100 percent of the receptacles surveyed had over 75 A available short circuit current. The ability of the circuit breaker to trip depends on the instantaneous trip level of the installed circuit breaker and the available short-circuit current. A 15 A circuit breaker with a 150 A instantaneous trip level should trip with a short-circuit fault in 84 percent of the receptacles surveyed. However, for a fault at the end of a 6-foot No. 18 AWG appliance cord plugged into the receptacle, the available fault current at only 78 percent of the receptacle locations would be sufficient to trip a 15 A circuit breaker. Similarly, a 15 A circuit breaker with a 195 A instantaneous trip level would trip with a short circuit fault in 69 percent of the receptacles surveyed. With a fault at the end of a 6-foot appliance cord plugged into the receptacle, the breaker would trip only 56 percent of the receptacles.

Figure 1.

### 15A Receptacle Circuits

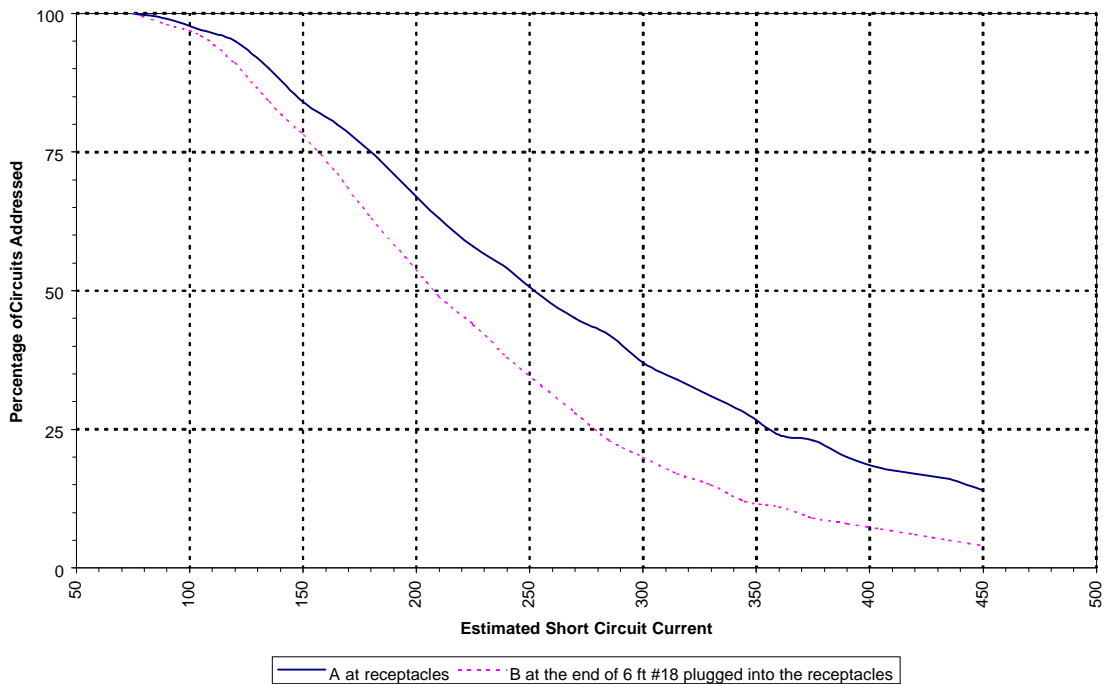

When an arcing fault occurs rather than a short circuit, the data is even less favorable. This is because 1) an arcing fault adds some impedance to the circuit that limits the fault current even further, and 2) parallel arcing faults have erratic current flow that reduces the rms current, which is needed to trip the circuit breaker. According to one manufacturer, these two factors increase the effective instantaneous trip level by 50 A.<sup>6</sup> In the previous example, for short-circuit currents, a circuit breaker with a 150 A instantaneous trip level would trip 84 percent of receptacles. For an arcing fault, however, the effective instantaneous trip level would increase to 200 A. Thus, the circuit breaker would trip in less than 69 percent of receptacles (the percentage associated with an instantaneous trip level of 195 A).

The results of the study sponsored by the EIA determined that lowering the instantaneous trip level below 105 A rms would provide a greater potential reduction in fire risk. Lowering the instantaneous trip level to 75 A rms to cover all receptacles would also increase the possibility of nuisance tripping. AFCI technology, on the other hand, has the ability to detect the current signatures of parallel arcs so that the effective instantaneous trip level can be lowered to 70 A rms without the increased risk of nuisance tripping.

### **Arc-Fault Circuit Interrupters (AFCIs)**

Presently, AFCIs are designed into conventional circuit breakers combining traditional overload and short-circuit protection with arc fault protection. The AFCI circuit breaker provides protection for branch circuit wiring and limited protection for power cords and extension cords. Some designs combine GFCI (ground-fault circuit interrupter) and AFCI protection (see section on GFCIs). Receptacle types are being developed, but no receptacle-type AFCIs were available at the time this paper was written.

Single-pole 15-ampere and 20-ampere AFCI circuit breakers are presently available, although additional AFCI design configurations are anticipated. Presently, the AFCI circuit breakers cost about the same as the GFCI circuit breakers, but costs are expected to decrease with demand. The AFCI circuit breakers have a test button and look similar to GFCI circuit breakers (see Figure 2). Like GFCIs, AFCIs require monthly testing to inform the user that the AFCI is functioning properly.

Figure 2.

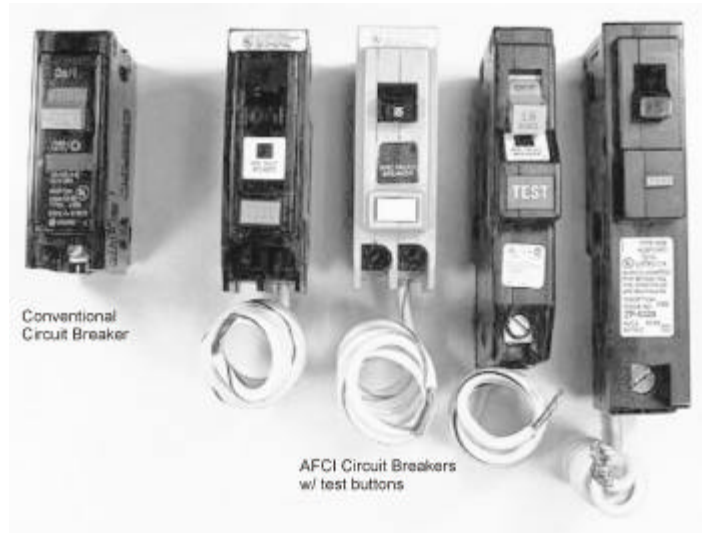

### **How AFCIs Work**

Both “good” and “bad” arcs produce a current signature or waveform. “Good” arcs are characterized by being periodic or repetitive (occur each 60 Hz cycle) and can be non-sinusoidal (not the shape of a sine wave). “Bad” arcs are characterized by non-periodic or non-repetitive waveforms. The AFCI circuitry continuously monitors current flow through the AFCI. AFCIs use detection circuitry to discriminate between normal and unwanted arcing conditions. Once an unwanted arcing condition is detected, the control circuitry in the AFCI trips the internal contacts, thus de-energizing the circuit and reducing the potential for a fire to occur.

Methods for the detection of “bad” arcs include looking at certain frequencies, discontinuities, and inconsistencies in the current waveform. For detection, both

magnitude and duration of a particular half cycle are required. Some detection algorithms also look at rising or falling edges of an arcing current for their detection criteria. The industry voluntary standard for AFCIs requires a trip if 8 half cycles of arcing occur within a 0.5 second window.\* An AFCI should not trip during normal current conditions.

Figure 3<sup>19</sup> is a block diagram of a single pole AFCI circuit breaker. The AFCI electronics function independently from the thermal and instantaneous sensing functions of the conventional circuit breaker. The AFCI electronics detect current flow from the load terminals with the use of a load current sensor. The load current sensor can be either a resistive sensor or a magnetic sensor. The output of the load current sensor is fed into an arc signature filter that passes frequency components of arcing waveforms while rejecting other power line frequencies. The arc signature filter output is amplified and fed into a logic circuit that determines if an unsafe condition exists. As discussed before, both amplitude and duration are used to detect the unwanted arcing condition. If the logic determines that the load must be de-energized, a signal is fed to a triac used to energize a solenoid that opens the circuit breaker contacts.

Figure 3.

---

\* UL 1699 defines an arcing half cycle as, “all of the current traces occurring within a period of 8.3 ms (for a device rated 60 Hz). Within that time period there may be current flow for some but not all of the time. Prior to and following each period of current flow, there may be a period of no current or very reduced current. Very reduced current is considered to be current with an amplitude less than 5% of the available current or current that continues for not more than 0.42 ms. This may last for either a portion of a half cycle or for several half cycles. A complete sinusoidal half cycle of current flow is not considered to be an arcing half cycle.”

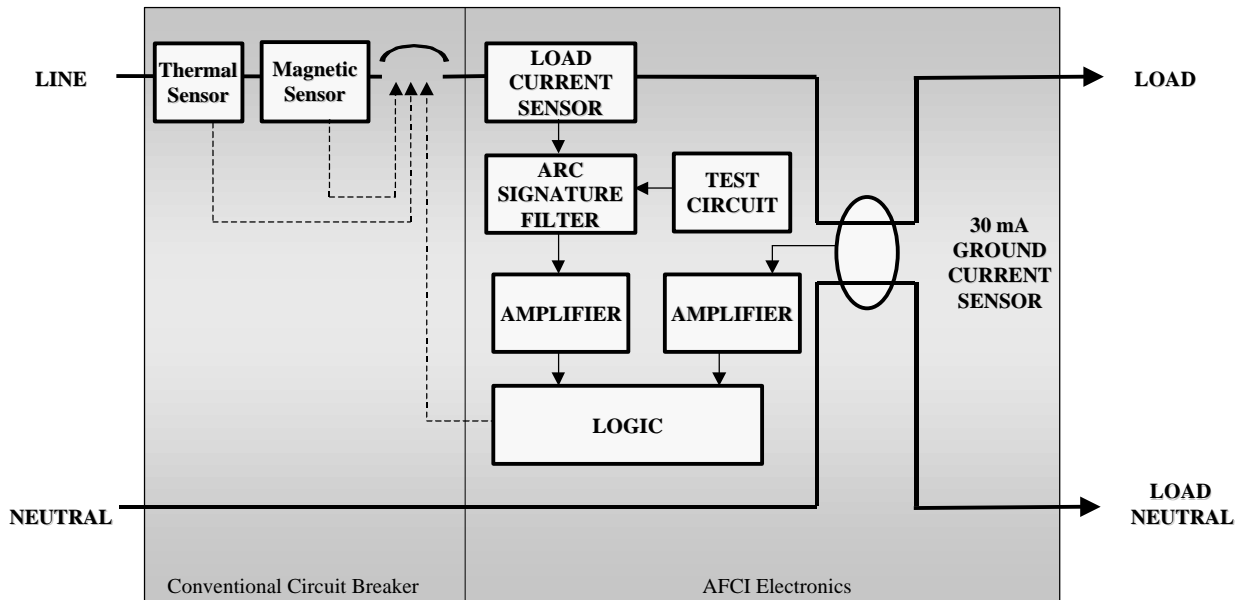

### Single Pole AFCI Circuit Breaker

An AFCI also uses a ground current sensor (typically 30 mA) for “pre-arcing” detection and protection. This sensor allows the AFCI to detect slowly-developing insulation breakdown that typically precedes line-to-ground and line-to-neutral arc faults. Additionally, lower level series arcing may become a fault to ground in three wire systems or systems that are grounded. The ground current sensor output is amplified and fed into the logic circuit. If the logic determines that the magnitude and duration of the ground fault is hazardous, the solenoid will open the circuit breaker contacts.

A test circuit is provided to ensure that the arc fault detection circuit is functioning properly. A test button is used to generate a signal that is similar to an arcing output waveform of the load current sensor. The test button will de-energize the circuit if the device is functioning properly.

An AFCI circuit breaker can be combined with personnel level GFCI protection by lowering the threshold of the ground current sensor to 6 mA. A second test circuit is required to test the GFCI function of the combination AFCI and GFCI device. Also, the grounded neutral protection is required per UL 943, *Standard for Ground Fault Circuit Interrupters*.

Figure 4<sup>19</sup> is a block diagram of a two-pole AFCI circuit breaker. This device can be used on a variety of circuits including 3-wire, 120/240 Vac circuits, 120 Vac shared neutral circuits, or 240 Vac circuits obtained from a 120/240 Vac source.<sup>20</sup> The shared neutral circuit, also referred to as a “home run” or “multi-wire branch” circuit, is a common household wiring technique that uses one three-conductor plus ground cable instead of two separate two-conductor plus ground cables to feed two branch circuits. Many electricians use this practice in order to save labor and material costs. These applications must use a load current sensor, arc signature filter, and amplifier for each of the phases L1 and L2. Although the logic circuit determines if a circuit needs to be de-energized, both phases must be de-energized, since the fault may be in the three-conductor plus ground cable. The device requires two test circuits, one for each phase. The ground current sensor uses all three conductors to sense leakage currents, and both circuits trip.

Figure 4.

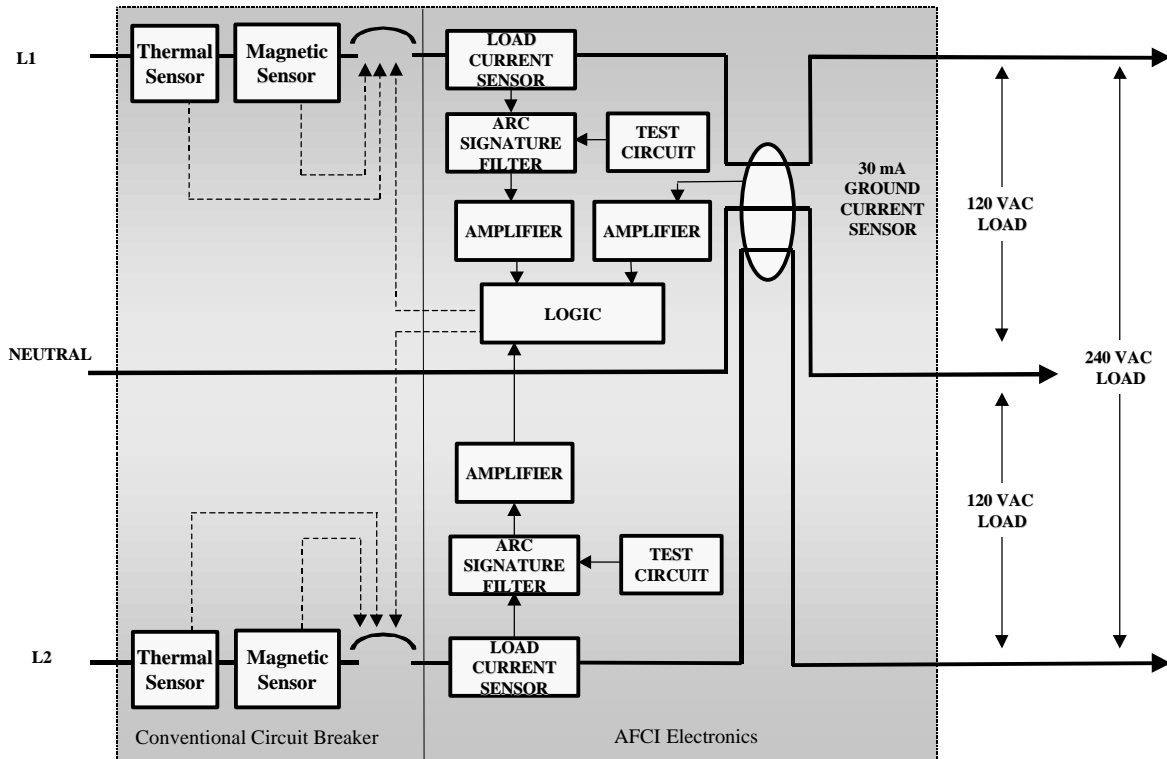

Two Pole AFCI Circuit Breaker

Similarly to the single pole, combination AFCI and GFCI, a two-pole AFCI circuit breaker can combine personnel GFCI protection. Like the single-pole version, an extra test button is required to test the GFCI function of the combination AFCI/GFCI.

The AFCI circuit breakers described above use analog circuitry with custom chips or integrated circuits (ICs) to perform some of the circuit functions. Similar arc detection technologies can be achieved using a digital approach. The digital AFCI can use the same



current sensor and ground current sensors. Both the current signal and the ground current signal are amplified and converted into a digital signal with an ADC (analog to digital converter). The microprocessor then calculates the line current and the irregularities in the current signals using special algorithms in software to determine if arcing is present. If the microprocessor determines that the load must be de-energized, a signal is fed to a triac used to energize a solenoid that opens the circuit breaker contacts. As in analog circuitry, a custom IC can be used to reduce the required space of the digital circuitry. The digital approach allows for easier algorithm changes in the development process and increased flexibility in the testing process.

Existing AFCIs do not detect another cause of electrical fires – the glowing connection – unless an arc or ground fault is also present.<sup>21</sup> A glowing connection is a special case of a high resistance connection that can dissipate a considerable amount of energy and glows to the point of incandescence.<sup>22</sup> In addition to their heat output, glowing and other poor connections are manifested by excessive voltage drop across the connection. The magnitude of the voltage drop varies with the impedance of the connection and the load current. (The impedance of the circuit will also have an effect on the ability of a conventional circuit breaker to instantaneously trip when the short circuit current is below the instantaneous trip threshold.) The AFCI will detect some of the secondary effects of the glowing connection, such as arc faults and ground faults. By detecting these secondary effects, the AFCI can eliminate a critical factor in further destruction – the flow of electric current.

## UL STANDARD FOR AFCIs

In December 1996, a task force of the Molded Circuit Breaker Section of the National Electrical Manufacturers Association (NEMA), with UL's participation, completed a draft standard for AFCIs. In the fall of 1997, the standard was transferred to UL for conversion to a UL standard for AFCIs. The first edition of the *Standard for Arc-Fault Circuit-Interrupters*, UL 1699, was published in February 1999. Prior to this time, AFCIs were listed under the *Standard for Molded-Case Circuit Breakers, Molded-Case Switches, and Circuit-Breaker Enclosures*, UL 489, and classified for mitigating the effects of arcing faults.

The first edition of UL 1699 has three major sections, which are summarized below:<sup>23</sup>

Efficacy Tests - The device shall demonstrate arc detection by sensing current levels and conditions unique to arcing and function to de-energize the circuit. Two methods are used to simulate arcing:

- The carbonized path method uses high voltage to cause electrical insulation pyrolysis across parallel conductors resulting in arcing.
- The point contact or guillotine method represents contact arcing when sharp objects cut through parallel wires.

Unwanted Tripping Tests - The device shall demonstrate the ability to avoid nuisance tripping with loads that might produce waveforms similar to an unwanted arc. The six categories of load conditions are:

- Inrush Current – These loads require high currents for initial startup of the load, such as tungsten-filament light bulbs and motors with starting capacitors.
- Normal Operation Arcing – These loads have normal operating arcs that are generally not hazardous. Examples of these loads are motors with brushes, thermostatically controlled heating appliances, wall switches, and unplugging of loads with power on.
- Non-sinusoidal Waveform – These loads have non-sinusoidal current waveforms during normal operation. The loads include electronic lamp dimmers, variable-speed power tools, switching power supplies in computers, and fluorescent lamps.
- Cross Talk – This test is designed to ensure that the device under test does not trip as the result of an arcing condition on an adjacent circuit.
- Multiple Load – This test uses multiple combinations of loads with non-sinusoidal waveforms to test for nuisance tripping.
- Lamp Burnout – These tests are designed to verify that the AFCI will not experience a nuisance-tripping problem when lamps burn out.

Operation Inhibition Tests - The device shall demonstrate that it can detect arcs and de-energize the circuit when it is in series or parallel with a range of circuit conditions that could hide, attenuate, or mask the arc signature. The three conditions are:

- Masking - The device is subjected to a variety of loads in series and parallel with the arc.

- EMI filters – EMI filters are installed on a branch circuit to determine if the filter affects the device’s ability to detect an arc.
- Line Impedance – Line impedance that might attenuate energy at certain frequencies is tested to determine if the device trips.

UL 1699 requires over 75 different tests to qualify the AFCIs for UL listing. UL 1699 also includes surge protection and test requirements similar to UL 943.

### **CPSC STAFF TESTS OF AFCIs**

In 1997, when the devices were first produced for sale, the CPSC staff began evaluating AFCIs. These first production samples were rated 15 A or 20 A, 120 V, single pole. The main objective of the tests was to determine if the AFCIs could distinguish an electrical signal of a normal load from that of an arcing fault and not pose a nuisance tripping problem. The CPSC staff conducted a series of tests to evaluate the AFCIs including both efficacy and unwanted tripping tests.

Tests followed the requirements established in the draft UL standard, although some tests were modified (more stringent than the standard) to simulate loading of appliances that might cause unwanted tripping (e.g. adding an additional 500 watts of load to the inrush current test or excessively loading and stalling power tools). Waveforms for the tests were captured and stored.

Figures 5 and 6 are representative waveforms recorded from the Efficacy Tests completed by the CPSC staff and are characteristic of “bad” arcs. Figures 7-9 are

representative waveforms from the Unwanted Tripping Tests and are characteristic of “good” or normal arcs.

Figure 5 shows a parallel arc waveform from a guillotine test using an SPT-2 No.16 AWG wire specimen. When the guillotine shorted the line and neutral conductors, arcing occurred up to the available fault current during portions of half cycles 1, 3, 4 and 5. As shown in Figure 5, arcing did not occur during half cycle 2. Waveforms from “bad” arcs have discontinuities and may not conduct on consecutive half cycles. Arcing from half cycles 3, 4 and 5 was above 70 A peak, and the AFCI tripped.

Figure 5.

Guillotine, SPT-2 16 AWG  
Voltage and Current

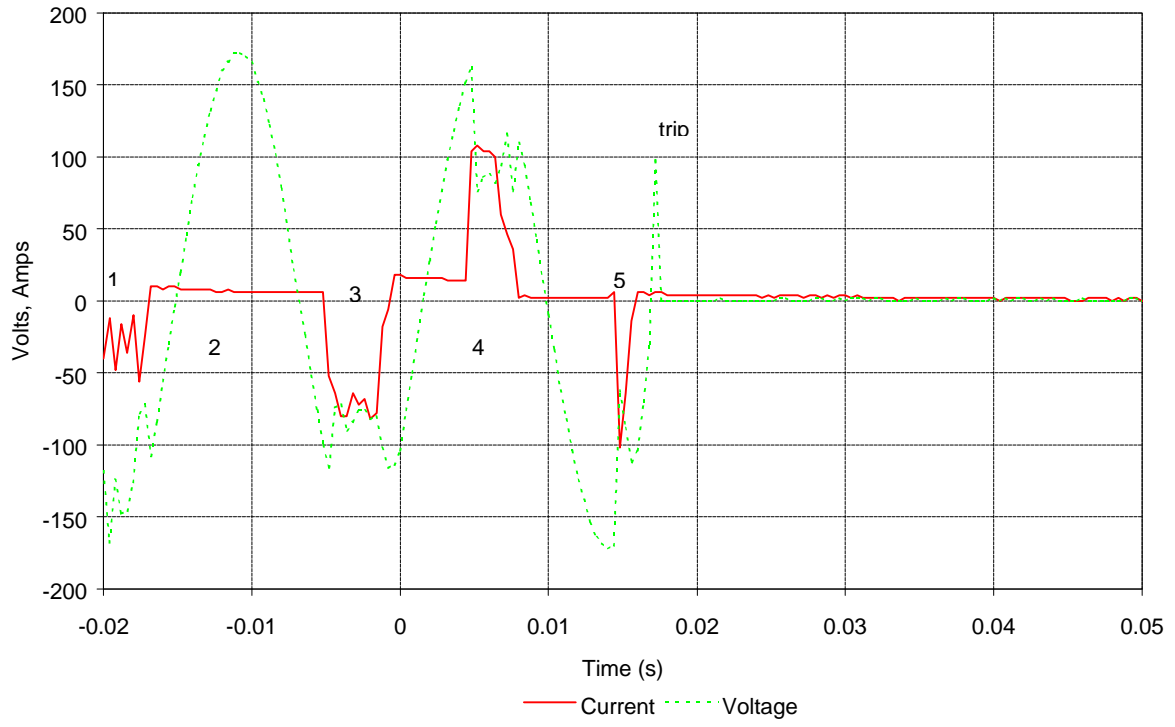

Figure 6 shows the results of a guillotine test on type NM-B 14-2 AWG wire with ground. This cable is the common cable installed in homes today. For this test, the AFCI was found to trip quicker than in the line-to-neutral fault in the SPT-2 cable. This is because the AFCI included a 30 mA ground current sensor for detection of ground faults. The guillotine created a ground fault between the bare ground conductor located between the line and neutral conductors. In most instances, a fault from either the line or neutral conductor will occur to the ground conductor next to it. The AFCI tripped after the first half cycle. The potentially hazardous currents shown in Figures 5 and 6 would not trip a conventional circuit breaker.

Figure 6.

Guillotine, NM-B 14-2 AWG  
Voltage and Current

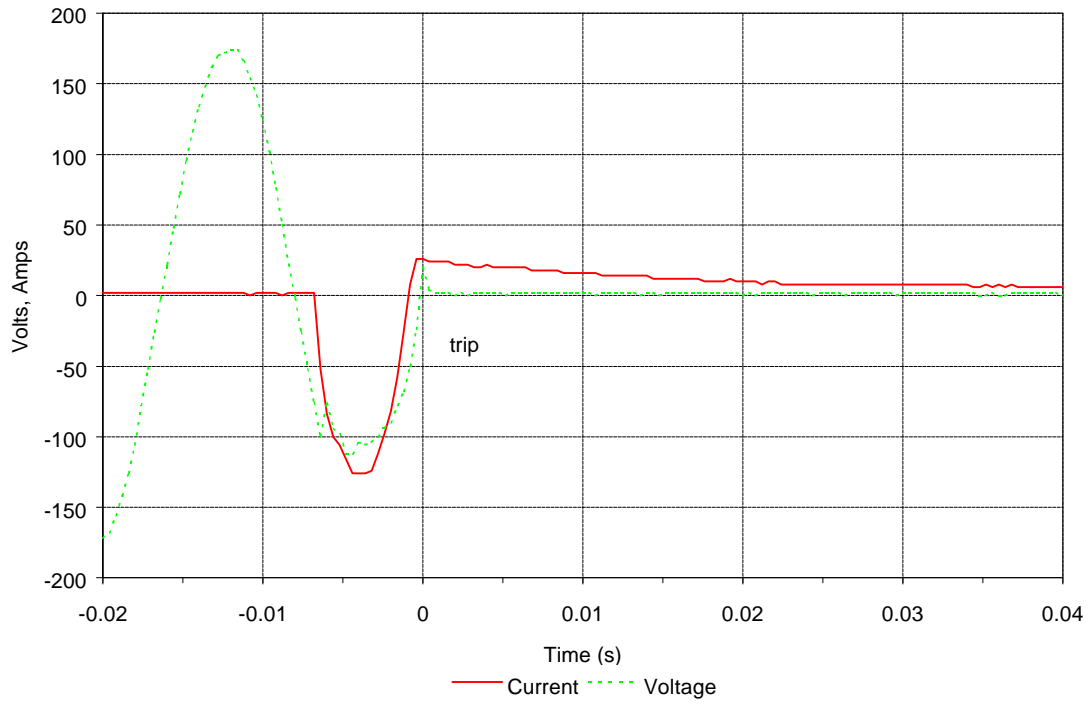



Figure 7 shows the inrush current of an 1800 watt tungsten filament lamp load. Typical inrush currents for lamps are 10-15 times greater than the steady-state currents and are larger when the current is switched on near the peak of the voltage and the bulbs are cool. In this case, a peak current of 150 A was measured with an 1800 watt load. The AFCI did not nuisance trip.

Figure 7.

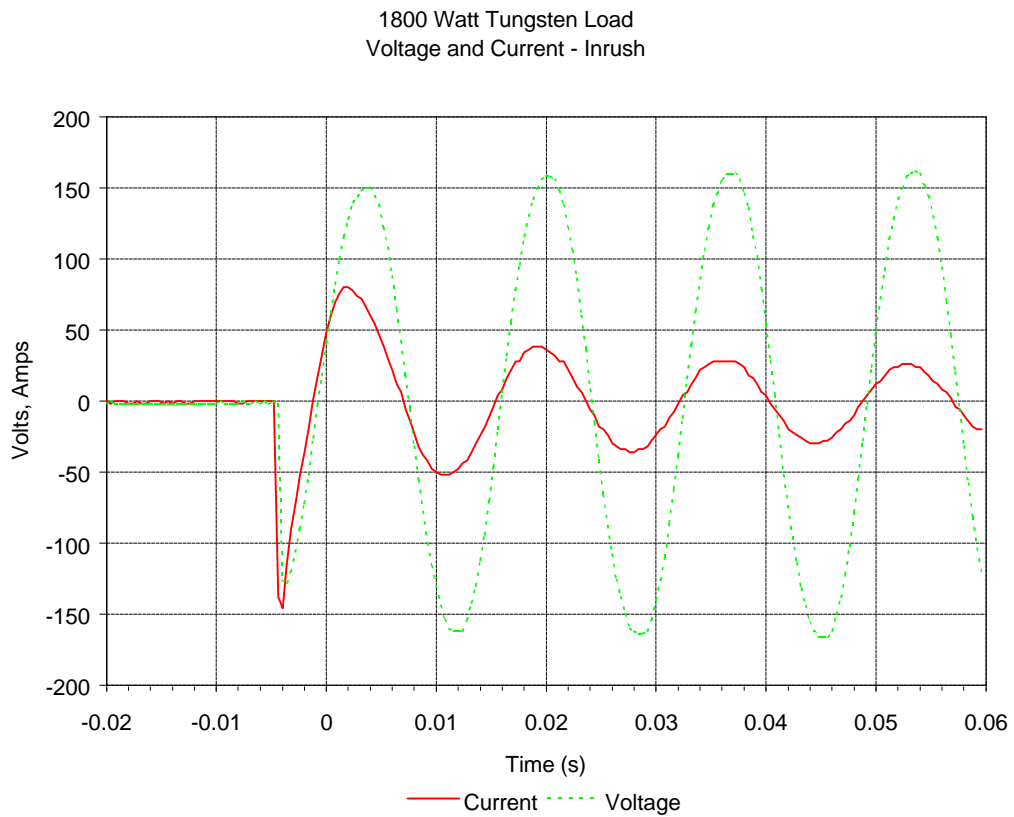

Figure 8 shows the current waveform for a 12 A rms air conditioner. Initially, only the fan is on so the current draw is low. When the compressor starts, it draws 80 A peak current for about 0.15 seconds (nine cycles of 60 Hz). The inrush current is approximately five times the steady state current draw. The AFCI did not nuisance trip.

Figure 8.

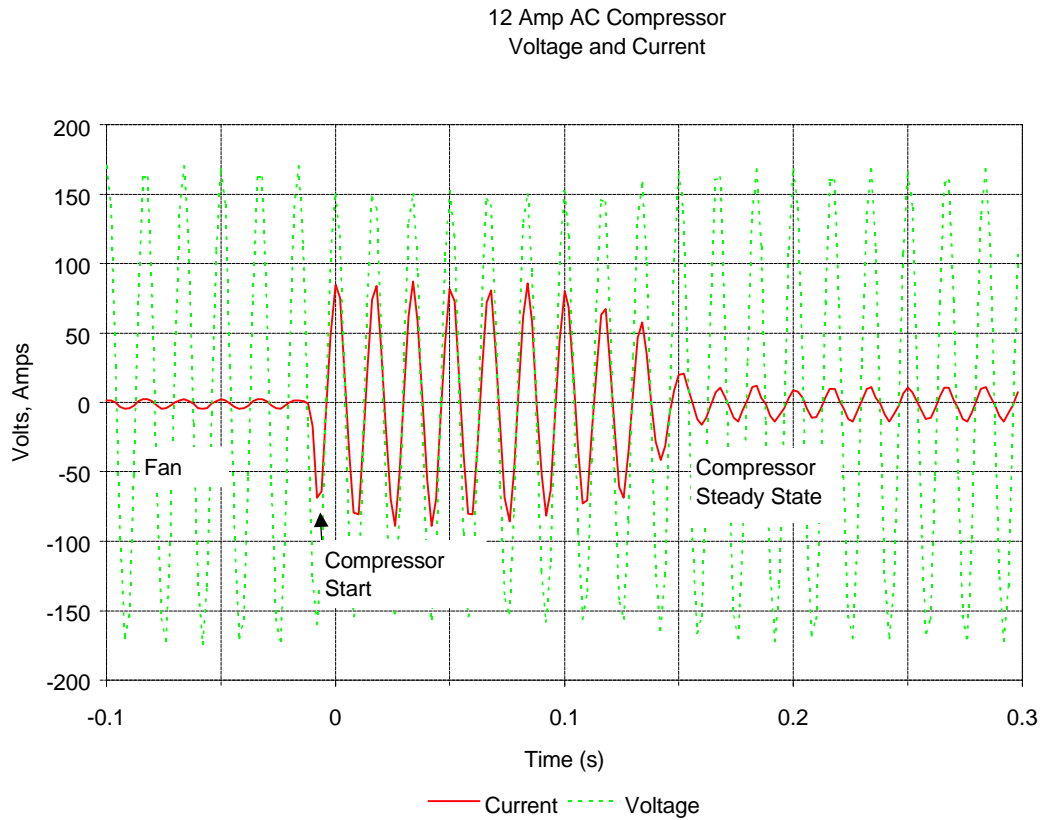
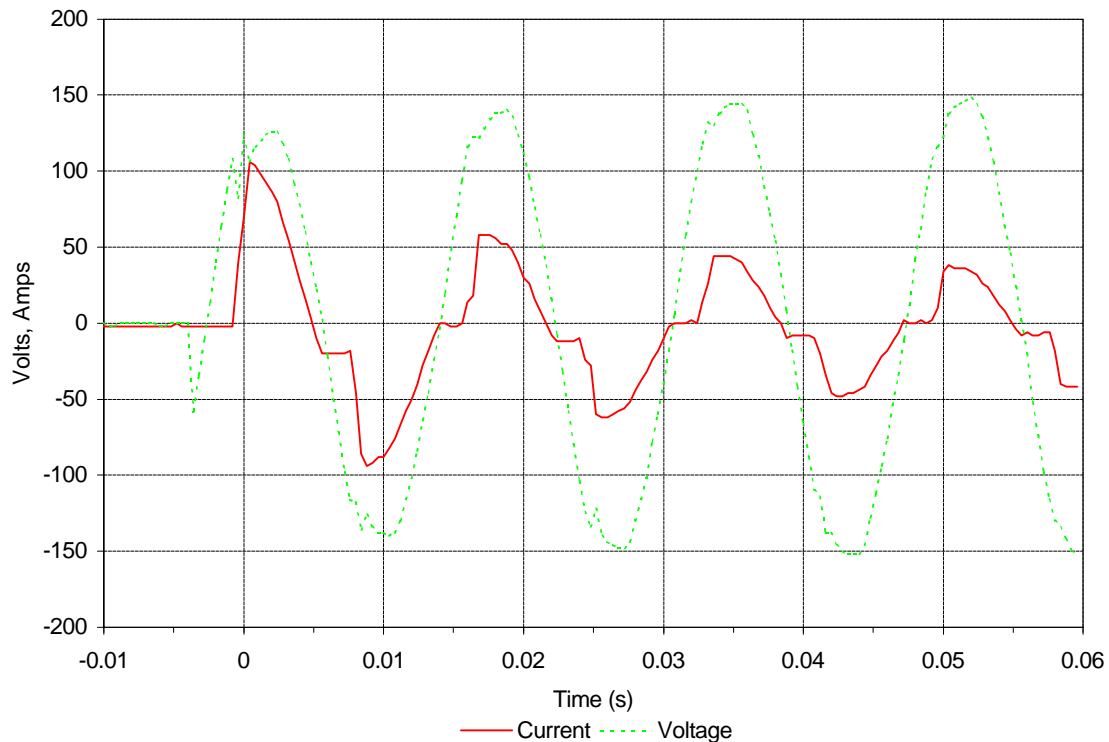

Figure 9 shows the current to three 500 watt halogen lamps with triac dimmers. The lamps were controlled by a single snap switch and were set to three-quarters power. The current waveform is non-sinusoidal because each lamp is controlled by a triac that switches current on during a portion of each half cycle. The phase of the current is delayed based on the dimmer switch setting. Initial peak inrush currents of 120 A were measured when the lamps were switched on. The AFCI did not nuisance trip.

Figure 9.

(3) 500 Watt Halogen Lamps  
Voltage and Current



CPSC staff completed four different efficacy tests on several AFCIs from different manufacturers. CPSC staff also completed over 25 unwanted tripping tests with these AFCIs. The AFCIs all passed.

The CPSC staff's tests verified that AFCIs would trip when "bad" arcing was simulated by shorting adjacent conductors and carbonizing insulation. In addition, AFCI circuitry distinguished "good" arcs or electrical signals of normal household loads without presenting nuisance tripping problems.

### **1999 NATIONAL ELECTRICAL CODE REQUIREMENTS**

The 1999 *National Electrical Code (NEC)* requires AFCIs on bedroom branch circuits effective in the year 2002.<sup>11</sup> AFCIs would replace the conventional thermal/magnetic circuit breakers currently used in a panel. Although the *NEC* requirement is only for bedroom circuits in new residential construction, AFCIs may be applied for added protection in other circuits and for installation in existing homes as well. Older homes with aging and deteriorating wiring systems can especially benefit from the added protection of AFCIs. AFCIs should also be considered whenever adding or upgrading a panel box while using existing branch circuit conductors.

### **GROUND-FAULT CIRCUIT INTERRUPTERS**

The AFCI should not be confused with the GFCI, or ground-fault circuit interrupter. The GFCI is designed to protect people from severe or fatal electric shocks, while the AFCI protects against fires caused by arcing faults. The GFCI also can protect

against some electrical fires by detecting arcing and other faults to ground,<sup>24</sup> but it cannot detect hazardous across-the-line arcing faults that can cause fires.

The *NEC* requires GFCI protection for receptacles located outdoors; in bathrooms, garages, kitchens, crawl spaces and unfinished basements; and at certain locations such as near swimming pools. A combination AFCI and GFCI can be used to satisfy the *NEC* requirement for GFCI protection only if it is specifically marked as a combination AFCI and GFCI.

#### **SUMMARY:**

Over 40,000 fires are attributed to home electrical wiring each year; arcing faults are one of the major causes of electrical wiring fires. To reduce the number of residential electrical fires, the U.S. Consumer Product Safety Commission sponsored a study of new technologies that could detect and monitor conditions that could lead to or cause electrical fires. The study, conducted by Underwriters Laboratories, led to the introduction of arc-fault circuit interrupter technology combined with conventional circuit breakers. This present generation of AFCIs offers protection to mitigate the effects of arcing faults without presenting nuisance tripping problems.

The 1999 *National Electrical Code (NEC)* requires AFCIs on bedroom branch circuits effective in the year 2002. Although the *NEC* requirement applies only to new residential construction, AFCIs may be used for installation in existing homes as well. Older homes with aging and deteriorating wiring systems can especially benefit from the added protection of AFCIs.

\* *Mr. Lee and Mr. Trotta are staff Electrical Engineers with the U.S. Consumer Product Safety Commission (CPSC) and each have over 13 years of experience in electronic detection systems, electrical distribution systems, and electrical consumer products. Mr. King is currently the Chief Engineer for Electrical and Fire Safety with the CPSC and has over 36 years of experience in electrical product safety.*

*The views are those of the authors and are not intended to represent the views of the Commission or other members of its staff. Since the article was written in the authors' official capacity, it is in the public domain and may be freely copied or reprinted.*

## References:

- 
- <sup>1</sup> Ault, Singh, and Smith, “1996 Residential Fire Loss Estimates”, U.S. Consumer Product Safety Commission, Directorate for Epidemiology and Health Sciences, October 1998, Tables 1, 6, 10, and 14.
- <sup>2</sup> Witt, Roger, Comment on Proposal Number 2-129, “National Electrical Code Committee Report on Comments”, NFPA 70 – A98 ROC, State Farm Insurance Co., p. 106.
- <sup>3</sup> Zlan Ltd Web Site, [On line] URL: <http://www.zlan.com/arc.htm>.
- <sup>4</sup> Smith and McCoskrie, “Residential Electrical Distribution System Fires”, U.S. Consumer Product Safety Commission, 1987.
- <sup>5</sup> Gregory, G. and Scott, G., “The Arc-Fault Circuit Interrupter: An Emerging Product”, IEEE Transactions on Industry Applications, Vol. 34, No. 5, September/October 1998.
- <sup>6</sup> Engel, J., Clarey R., and Doring, T., “Arc-Fault Circuit Interrupters: New Technology for Increased Safety”, International Association of Electrical Inspectors, 1997.
- <sup>7</sup> NFPA 921, Guide for Fire and Explosive Investigations 1998 Edition, National Fire Protection Association, Inc., Chapter 14.
- <sup>8</sup> Roberts, Earl, Overcurrents and Undercurrents, Electrical Safety Advances through Electronics, Reptec, 1996, Chapters 1-2.
- <sup>9</sup> “Technology for Detecting and Monitoring Conditions That Could Cause Electrical Wiring System Fires”, Underwriters Laboratories Inc., U.S. Consumer Product Safety Commission, September 1995.
- <sup>10</sup> “Report of Research on Arc-fault Detection Circuit Breakers for National Electrical Manufacturers Association”, Underwriters Laboratories, March 15, 1996.
- <sup>11</sup> NFPA 70, National Electrical Code 1999 Edition, National Fire Protection Association, Inc., 1998, Article 210.
- <sup>12</sup> The New IEEE Standard Dictionary of Electrical and Electronic Terms, Institute of Electrical and Electronics Engineers, 1993, p. 51.
- <sup>13</sup> Technical notes “Fire Shield Cord Sets”, Technology Research Corporation, 1999.
- <sup>14</sup> UL 943, Standard for Safety, Ground-Fault Circuit-Interrupters, Underwriters Laboratories Inc., August 1993.
- <sup>15</sup> National Association of Home Builders, article.
- <sup>16</sup> Yereance, Robert A., Electrical Fire Analysis, Charles C. Thomas - Publisher, 1987, pp.132-138.
- <sup>17</sup> UL 489, Standard for Molded-Case Circuit Breakers, Molded-Case Switches, and Circuit-Breaker Enclosures, Oct 31, 1996, pp. 33-46.
- <sup>18</sup> “An Evaluation of Branch-Circuit Circuit-Breaker Instantaneous Trip Levels”, Underwriters Laboratories Inc., Electronic Industries Association, October 25, 1993.
- <sup>19</sup> Block Diagram, Dr. Joseph Engel, Cutler-Hammer, January 1999.
- <sup>20</sup> Product Brochure “Cutler-Hammer Arc Fault Circuit Interrupters”, October 1997.
- <sup>21</sup> Gregory, George D., “Using Arc-Fault Circuit Interrupters to Reduce Residential Fires”, EC&M, November 1997.
- <sup>22</sup> Meese and Beausoleil, NBSIR 77-608341: “Exploratory Study of Glowing Electrical Connections,” October 1977.
- <sup>23</sup> UL 1699, Standard for Arc-Fault Circuit-Interrupters, Underwriters Laboratories Inc., Feb 26, 1999, pp. 27-50.
- <sup>24</sup> Gordon, Ted, “Fire Protection Features of GFCIs”, ASHI Technical Journal, U.S.Consumer Product Safety Commission, Spring 1993.