

Minute
No. 442

Finned Tube Heating Boilers

K. Fenning pointed out that Alberta had witnessed some incidents associated with blockage of combustion products in a finned tube area of heating boilers. A Bulletin was released in Alberta on December 31, 1993 (see Appendix B). An investigation of the subject boilers indicated that the temperature of the recirculated water to the boiler was not low (it was 155°F). Fifteen additional boilers installed in Alberta were inspected and all were found to have some degree of blockage. It was noted that the manufacturer's printed instructions prescribed a very intense schedule of heat exchanger inspection and maintenance: "... check the heat exchanger for fouling after the following periods of operation: 24 hours, 7 days, 30 days, 90 days, and once every six months thereafter". It was pointed out that inspection of the heat exchanger is very difficult requiring major disassembly of the appliance. Similar problems to that reported in Alberta were also reported in Saskatchewan and the Northwest Territories. V. Sztainbok did not believe that CGA Approvals had received any reports. If these incidents were in fact related to CGA certified products, he requested that data be sent to CGA. CGA will investigate and take up the matter with the manufacturer.

The Council agreed that the Standards Committee should consider this issue and consider adding coverage to lessen reliance on inspection and maintenance and to require a flame roll-up switch. It was felt that unless the Standards Committee takes action to upgrade the standard for boilers, installation restrictions, similar to those for swimming pool heaters (ie. prohibiting installations in dwelling units), may have to be imposed.

Honeywell

To: FAX # 216-642-3463 Julie Cairns / Std. Staff
FAX # 703-525-8159

From: Al Anderson

Subject: Water Heater Subcomm. Agenda
Item #13 for Sept. 23-24

When the Subcommittee reviews Item #13 please have them also look at page 2-5 of item #2. The Dampor Subcomm. has a working Group to develop a Harmonized Std. They too want to remove the construction/performance requirements in all appliance std's for vent dampers. This is the same goal being proposed by Mr. Grieco.

Hopefully the water heater Subcomm. will support the Vent Dampor proposal.

Thanks,
Al 9/8/93

ITEM 13.
Z21/CGA Joint Water Heater
Subcommittee Meeting,
September 23-24, 1993

**REPLACE AUTOMATIC VENT DAMPER SECTIONS IN Z21
WATER HEATER STANDARDS WITH REFERENCE TO ANSI Z21.66**

Action Requested

Replace the automatic vent damper sections of Z21.10.1, Z21.10.3, and Z21.56 with a reference to the *Standard for Automatic Vent Dampers for Use with Gas-fired Appliances*, ANSI Z21.66.

Background

Attached is an October 19, 1992 letter from Mr. Spencer Grieco, Director, Product Certification, American Gas Association Laboratories. (See Attachment I.)

Additional Background

Also attached are Sections 1.26 and 2.25 under Z21.10.1-1990, which is similar to coverage contained in the Z21.10.3 and Z21.56 standards. (See Attachment II.)

(b) CLEARER 3/13/95
✓ No items identified



Laboratories

October 19, 1992

Mr. Allen J. Callahan
Z21 Administrative Secretary
8501 E. Pleasant Valley Road
Cleveland, Ohio 44131

Subject: Agenda Item for Subcommittee on Standards for Gas Water Heaters

Dear Mr. Callahan:

Action Requested: Review sections 1.26 and 2.26 of ANSI Z21.10.1-1990, sections 1.26 and 2.25 of ANSI Z21.10.3-1990 and sections 1.24 and 2.22 of ANSI Z21.56-1989 to determine, if they can be deleted from the standard and replaced with simple references to ANSI Z21.66 Automatic Vent Dampers as shown below.

Background: There exists an ANSI standard Z21.66, Automatic Vent Damper Devices for use with Gas-fired Appliances. This standard contains the same provisions referenced in the above sections. We believe the automatic vent damper sections were added to the water heater standards before ANSI Z21.66 was adopted.

The Laboratories recommends that the wording in the above referenced sections be replaced with the following wording.

1.26 AUTOMATIC VENT DAMPERS

Automatic vent dampers, when provided, shall comply with the applicable construction provisions of the Standard for Automatic Vent Dampers for Use with Gas-fired Appliances, ANSI Z21.66.

2.26 AUTOMATIC VENT DAMPERS

Automatic vent dampers, when provided, shall comply with the applicable performance provisions of the Standard for Automatic Vent Dampers for Use with Gas-fired Appliances, ANSI Z21.66.

Your consideration of this matter is appreciated.

Sincerely,

A handwritten signature in black ink that reads 'S. Grieco'.

Spencer Grieco
Director
Product Certification

Excerpts from Z21.10.1-1990:

PART I
CONSTRUCTION

1.26 AUTOMATIC VENT DAMPER DEVICES

1.26.1 The damper of a vent damper device shall be downstream of both the draft hood inlet and the draft hood relief opening and shall not restrict either.

1.26.2 A vent damper device shall be suitable for attachment to the draft hood outlet or shall be an integral part of the draft hood. If an interconnecting section of vent connector is required, it shall be supplied by the water heater manufacturer attached to either the draft hood or the vent damper device.

1.26.3 All parts of a vent damper device, including fasteners, shall be corrosion resistant, suitable for the application and temperatures to which exposed and shall not show evidence of deterioration during the tests specified herein.

Metal parts in contact with flue gases or subject to condensation shall be at least one of the following:

- a. Aluminum-coated steel at least 0.018 inch (0.457 mm) thick with not less than 0.40 ounces per square foot (0.123 kg/m²) of aluminum with the bond between the steel and aluminum being an iron-aluminum alloy;
- b. Chromium-coated low-carbon steel in which the chromium is diffused into the surface of the steel to form an iron-chromium alloy;
- c. Type 1100 aluminum at least 0.016 inch (0.406 mm) thick; or
- d. Other metal having equivalent durability and resistance to corrosion and heat.

Cast iron may be used for nonmoving parts if it can be demonstrated that corrosion or heat will not impair the intended function and durability of the damper.

1.26.4 A vent damper device that is not an integral part of the draft hood shall have a single inlet, a continuous vent gas passageway and a single outlet. The outlet connection shall accommodate a vent connector of integral inch diameter size. Both the inlet and outlet connections shall have at least a 1¼-inch (31.8 mm) lip for attachment.

1.26.5 For a water heater equipped with a continuous pilot, the minimum internal free venting area of the vent gas passageway of a vent damper device, with the damper in the closed position, shall be not less than 1/2 square inch (3.2 cm²).

1.26.6 A water heater equipped with a vent damper device shall have two automatic valves, in series, each of which opens and closes the main gas supply when called upon to function. For the purposes of this provision, a thermostatically operated valve is an automatic valve.

1.26.7 All electrical components of an electrically operated vent damper device shall be factory wired into the electrical circuit of the water heater, or the vent damper device shall be supplied with a wiring harness. A connection diagram shall be supplied showing the exact arrangement of the wiring. (See 1.30.3-d.)

1.26.8 The mechanical circuits and connections of a mechanically actuated vent damper device shall comply with the following:

- a. All materials and fittings built in or supplied by the manufacturer with the vent damper device shall be submitted for examination.
- b. All materials and fittings supplied for use with and as a part of the vent damper device shall be judged with respect to their suitability for the particular application.
- c. The general construction and assembly of mechanical circuits shall be of a neat and workmanlike character and shall be mechanically secure without strain on any member. The circuits shall be positively located, supported and protected against damage from moving parts. Mechanical circuit material shall be protected from any combustion product condensate unless suitable for such service.
- d. Connections which need to be broken for any component intended to be serviced shall be made in such a manner that they may be disconnected and reconnected without new connections being required.

1.26.9 A thermally actuated vent damper device shall have no friction surfaces, bearings or hinges, unless the vent damper device includes features that will prevent draft hood spillage in the event of seizure of friction surfaces, bearings or hinges.

1.26.10 The damper of an electrically operated or mechanically actuated vent damper device shall assume its open position in the event of motive power failure or deenergization of the vent damper device, unless electrically interlocked with an automatic gas ignition system so as to prevent operation of the automatic gas ignition system when the damper is in other than the fully open position, or unless the loss of

motive power will prevent operation of the automatic gas ignition system when the damper is in other than the fully open position.

1.26.11 Operation of an electrically operated or mechanically actuated vent damper device shall produce a single closed position of the damper.

1.26.12 Electrically operated and mechanically actuated vent damper devices shall be equipped with means which will visually indicate the position of the damper when the vent damper device is installed as intended.

1.26.13 Electrically operated and mechanically actuated vent damper devices shall incorporate integral means actuated directly by the damper, or by the assembly of parts securely attached to the damper so as to maintain a fixed relationship to the damper, which will provide an interlock with both the automatic valves specified in 1.25.6 to prevent main burner firing unless the damper is in the fully open position.

PART II

PERFORMANCE

2.25 AUTOMATIC VENT DAMPER DEVICES

Whenever the use of air above room temperature is specified and required for use in conducting the following performance tests, flue gases from a water heater or burner assembly, mixed with air to obtain the specified temperature, shall be used.

2.25.1 Strength

A vent damper device shall be sufficiently rigid in construction to withstand a load equivalent to the following without impairment of operation or significant distortion.

Method of Test

The vent damper device shall be installed on the appliance as specified in the manufacturer's installation instructions. The vent damper device shall then be operated for 10 cycles before any load is imposed to ascertain that the damper is operating properly.

a. A vent damper device having a vertical outlet shall have a vertical compression load, equal to 5 pounds per inch (0.09 kg/mm) of nominal outlet diameter, applied without impact to the outlet. With this load imposed, the vent damper device shall be operated for 10 cycles, shall operate properly, and shall exhibit no significant distortion upon visual examination.

b. A vent damper device having a horizontal outlet shall have a 10-foot (3.05 m) length of vent pipe, made of sheet steel not less than 0.0195* inch (0.495 mm) thick, of suitable diameter attached in a horizontal position to the outlet, the other end of the vent pipe being supported at a point not more than 1 inch (25.4 mm) from its extremity. With this load imposed, the vent damper device shall be operated for 10 cycles, shall operate properly, and shall exhibit no significant distortion upon visual examination.

2.25.2 Operation Under Variable Voltage or Variable Motive Power

a. An electrically operated vent damper device shall function properly and shall not adversely affect the operation of the appliance control system when the electrical supply voltage to the water heater is varied over a range of 85 to 110 percent of the voltage marked on the appliance rating plate.

Method of Test

The vent damper device shall be installed on the appliance as specified in the manufacturer's installation instructions.

The supply voltage to the appliance shall be adjusted to 85 percent of the voltage marked on the appliance rating plate and, with the appliance at room temperature, the appliance control system shall be operated, by a switch in the thermostat circuit, to allow the main burner to alternately operate and turn off. This procedure shall be repeated 10 times, and during each cycle the vent damper device and main burner automatic gas valve shall function properly. The damper shall be open whenever the gas is admitted to the main burner.

This procedure shall be repeated with the supply voltage to the appliance adjusted to 110 percent of the voltage marked on the appliance rating plate.

b. A mechanically actuated vent damper device shall function properly when the motive power is varied over a range of 75 to 125 percent of the range of motive power marked on the vent damper device (see 1.31.34-d).

Method of Test

At room temperature, damper operation shall be observed when the motive power to the vent damper device is 75 and 125 percent of the range of motive power. The damper shall function properly for 10 cycles under each of these conditions.

* This corresponds to No. 24 U.S. Standard gage sheet steel with all applicable minus tolerances included.

2.25.3 Damper Force of a Thermally Actuated Vent Damper Device

This test shall be conducted before conduct of 2.25.5.

The damper of a thermally actuated vent damper device shall be capable of exerting a force of at least 2 ounces (57 gram-force) when moving in both the direction to open the damper and the direction to close the damper.

Method of Test

The vent damper device shall be installed in the position(s) specified in the manufacturer's installation instructions in a simulated venting system capable of alternately delivering to the vent damper device a supply of room temperature air and a supply of air at a temperature of 575 ± 25 F (301.5 ± 14 °C).

The damper force shall be measured using a strain gage or equivalent instrument coupled to the damper at the location that undergoes the greatest amount of movement as the damper goes from the closed to the open position.

The vent damper device shall be at room temperature, with the damper in the closed position. Air at a temperature of 575 ± 25 F (301.5 ± 14 °C) shall then be passed through the vent damper device. The force exerted by the damper to move from its closed position toward the open position shall be measured and shall be at least 2 ounces (57 gram-force).

The strain gage shall then be coupled to the damper in the opposite direction and room temperature air passed through the vent damper device. The force exerted by the damper to move from its open position toward the closed position shall be measured and shall be at least 2 ounces (57 gram-force).

2.25.4 Exposure to Temperature Extremes

The vent damper device shall function properly and not be damaged after exposure to high and low temperature extremes.

Method of Test

a. The vent damper device shall be installed in a simulated venting system in the position(s) specified in the manufacturer's installation instructions. The damper shall be opened in a normal manner and maintained in this position for a period of 24 hours with the air at a temperature of 575 ± 25 F (301.5 ± 4 °C) continually passing through the vent damper device.

At the end of this period, room temperature air shall be introduced until the vent damper device has been brought to room temperature, and the vent damper device shall then be operated for 10 cycles to determine that it functions properly and has not become damaged.

b. The vent damper device, with the damper in the closed position, shall be maintained in an ambient temperature of 32 ± 5 F (0 ± 3 °C) for a period of 24 hours.

At the end of this period, the vent damper device shall be operated for 10 cycles to determine that it functions properly and has not become damaged. Electrically operated and mechanically actuated vent damper devices shall be subjected to the ambient temperature of 32 ± 5 F (0 ± 3 °C) while they are operated for these 10 cycles.

c. In addition, a thermally actuated vent damper device shall be maintained in an ambient temperature of 725 ± 25 F (385 ± 14 °C) for a period of 2 hours.

At the end of this period, room temperature air shall be introduced until the vent damper device has been brought to room temperature, and the vent damper device shall then be operated for 10 cycles to determine that it functions properly and has not become damaged.

2.25.5 Continued Operation

A vent damper device shall withstand 100,000 cycles of opening and closing the damper without any mechanical failure, impairment of operation, or damage.

Method of Test

The vent damper device shall be installed in the position(s) specified in the manufacturer's installation instructions in a simulated venting system capable of alternately delivering to the vent damper device a supply of room temperature air and a supply of air at a temperature of 575 ± 25 F (301.5 ± 14 °C).

The following cycling sequence, as applicable, shall be repeated until a total of 100,000 cycles of opening and closing of the damper have been completed, after which the vent damper device shall function properly and not be warped, bent, broken or otherwise damaged.

a. Electrically operated and mechanically actuated vent damper devices:

A control system which will actuate the damper of the vent damper device to alternately open and close shall be connected to the vent damper device and the air delivery means.

The damper shall be caused to assume its open position, and a supply of air at 575 ± 25 F (301.5 ± 14 °C) shall be passed through the vent damper device for at least 5 seconds. This temperature shall be measured in the air stream at the outlet of the vent damper device.

The source of heat for the air supply shall then be shut off and the damper caused to assume its closed position for at least 5 seconds. The damper shall then be caused to assume its open position until the air passing through the vent damper device attains a temperature of 175 ± 25 F (79.5 ± 14 °C).

The damper shall then be caused to assume its closed position for at least 5 seconds, after which the damper shall be caused to assume its open position and the source of heat for the air supply turned on.

b. Thermally actuated vent damper devices:

The damper shall be allowed to assume its open position by passing a supply of air at 575 ± 25 F (301.5 ± 14 °C) through the vent damper device. This temperature shall be measured in the air stream at the outlet of the vent damper device.

After the damper has been in the open position for at least 5 seconds, the source of heat for the air supply shall be shut off and room temperature air passed through the vent damper device.

After the damper has been in the closed position for at least 5 seconds, the source of heat for the air supply shall again be turned on.

ITEM 14.
Z21/CGA Joint Water Heater
Subcommittee Meeting,
September 23-24, 1993

**REVIEW EFFORTS TO REVISE WIND TEST
CRITERIA FOR FURNACES AND BOILERS**

Action Requested

Review for information efforts to revise the wind test criteria for boilers and furnaces.

Background

Attached for review are letters dated October 30 and December 8, 1992, to manufacturers of furnaces and boilers certified by the American Gas Association Laboratories (AGAL), from Mr. Spencer P. Grieco, AGAL Product Certification. The attached letters outline industry efforts to revise the current wind test criteria to primarily address boilers and furnaces which are designed to be mechanically vented horizontally through an outside wall.

Additional Background

Subsequently, the AGAL has agreed to further modify its adopted "interim wind test protocol," based on the outcome of consideration by the Technical Working Group (TWG) of the joint Z21/CGA furnace subcommittee, at its June 1993 meeting.

It is anticipated that the furnace subcommittee will review the above efforts at its September 21-22, 1993 meeting in Cleveland. A verbal report will be made at this meeting on the outcome of the furnace subcommittee's review.

Additional Information

Initial indications are that the AGAL plans to use the revised wind test criteria for testing water heaters which are designed to mechanically vent horizontally through an outside wall.

At its May 1993 meeting, the joint Z21/CGA boiler subcommittee reviewed the above efforts regarding the revised wind test criteria. The boiler subcommittee took no action on this item, and requested clarifications of some aspects of the revised criteria.

(14-1)

ADJ. CLEARING 3/13/95
✓ No. 113-10-111-1

Comments Processed

**IMPORTANT LETTER
FOR INFORMATION ONLY**

October 30, 1992

TO: MANUFACTURERS OF CERTIFIED FURNACES AND BOILERS

SUBJECT: REVISION OF INTERIM WIND TEST PROTOCOL

ACTION REQUESTED:

This letter provides notice that A.G.A. Laboratories has adopted a revised interim wind test protocol for evaluating side wall vented, mid-efficiency gas furnaces and boilers.

Your firm may need to adopt revised design and testing practices to assure that your products meet this new protocol.

BACKGROUND

On April 14, 1992, a meeting was held in Cleveland, Ohio with industry personnel including representation from four Nationally Recognized Testing Laboratories. The purpose of the meeting was to determine if wind testing procedures are being conducted according to that written in the ANSI Standards.

As a result of that meeting the group recommended that the testing laboratories continue to conduct wind test as has been done in the past with existing equipment including portable wind apparatus used in manufacturer's laboratories certified by A.G.A. The group also suggested that the harmonized furnace task group continue to investigate the issue of wind apparatus to see if the current portable equipment being used meets the "intent" of the standards.

On July 13 & 14 the Z21/CGA Joint Central Furnace Technical Working Group met and discussed the wind test issue. As a result, they suggested revisions to the wind test for "Furnaces Vented Horizontally Through An Outside Wall."

A.G.A. LABORATORIES ACTION PLAN

The Laboratories has adopted the suggested revisions to the wind test as an interim wind test protocol. A copy of those changes are enclosed for your information. Please note that the suggested revisions do not apply to "Direct Vent Furnaces" or "Central Furnaces For Outdoor Installation." The changes also include a reduction in the wind velocity from 40 mph to 31 mph.

Any comments or questions to this interim wind test protocol should be directed to me or Dick Weiser, Manager, Production Control and Planning.

Sincerely yours,

SPENCER P. GRIECO
Director
Product Certification

PART II
GAS-FIRED CENTRAL FURNACES
PERFORMANCE

2.33 FURNACES VENTED HORIZONTALLY THROUGH AN OUTSIDE WALL

A furnace for indoor installation designed to vent the flue gases horizontally through an outside wall, shall comply with 2.33.1 through 2.33.4 with both the maximum and the minimum vent lengths specified by the manufacturer (see 1.2.23 and 2.2.5).

2.33.1 A manually ignited pilot(s) shall be capable of being ignited when the vent terminal is exposed to the effect of a wind having a nominal velocity of 10 miles per hour (4.47 m/s).

Method of Test

The test shall be conducted at normal inlet test pressure.

The furnace shall be installed as specified in 2.25.1. Deflector walls shall be installed in order that the wind from the wind apparatus shall not affect that section of the furnace normally located indoors.

A wind having a nominal velocity of 10 miles per hour (4.47 m/s) (0.04 inch water column (10 Pa) static pressure measured on a flat surface perpendicular to the wind source) shall be produced by a blower and directed against the vent terminal. The blower shall be located so the wind is directed perpendicularly to the surface of the wall structure to which the terminal is attached.

At the discretion of the testing agency, additional tests may be conducted with a wind of the same velocity directed from other directions.

With the furnace subjected to the above wind conditions, the pilot(s) shall be capable of being ignited.

2.33.2 The main burner(s) shall not become extinguished and shall ignite from the automatic ignition device(s) without excessive delay, and intermittent and interrupted ignition systems shall ignite when the vent system is exposed to a vent pressure of 0.40 inch water column (100 Pa) [31 miles per hour (13.86 m/s) wind velocity].

Method of Test

These tests shall be conducted at normal inlet test pressure.

a. The test method specified in 2.33.1 shall be applied when testing with a wind directed other than perpendicular to the wall, except that the wind produced by the blower shall have a nominal velocity of 31 miles per hour (13.86 m/s) [0.40 inch water column (100 Pa) velocity pressure measured with a pitot tube at the vent terminal].

The pilot(s), if provided, shall be ignited before the furnace is subjected to the wind. While operating under the above wind conditions, the pilot(s) when operating alone, and the pilot(s) and main burner(s) when operating simultaneously, shall not become extinguished during a 10-minute period.

The main burner valve shall then be shut off. After a period of at least 30 seconds, the main burner valve shall be turned on. An intermittent or interrupted ignition system (if provided) shall ignite, and the main burner gas shall ignite from the automatic ignition devices(s) without excessive delay. The furnace shall also comply with this test when the burner(s) is turned on and off by the automatic controls.

At the discretion of the testing agency, additional tests may be conducted with a wind of the same velocity directed from other directions.

b. The following test method shall be applied at the maximum vent length specified.

Remove only the vent terminal from the horizontal vent, when a vent terminal is used. Equip the vent pipe with a piezo ring (see Figure 3) 12 inches (805 mm) from the outlet of the horizontal vent. Connect the piezo ring to a differential pressure gage which can be read directly to within 0.005 inch water column (1.24 Pa) pressure. The manometer reference pressure connection shall be extended to a point adjacent to the furnace combustion air supply opening.

Turn off the gas supply to the furnace. Start furnace operation. Restrict the end of the vent until the pressure at the piezo ring reaches 0.40 inch water column (100 Pa). Stop furnace operation. Turn on gas supply to the furnace. With the restriction still in place, start the furnace operation from a cold start. While under the above condition, the pilot(s) when operating alone, and the pilot(s) and main burner(s) when operating simultaneously, shall ignite and not become extinguished. After steady-state conditions are attained readjust the restriction to maintain 0.40 inch water column (100 Pa). While operating under the above condition, the pilot(s) and main burner(s) shall not become extinguished during a 10-minute period. While maintaining the vent pressure of 0.40 inch water column (100 Pa) the burner(s) shall be turned on and off by the automatic controls, and the main burner(s) shall ignite without excessive delay.

2.33.3 A furnace shall not produce a concentration of carbon monoxide in excess of 0.04 percent in an air-free sample of the flue gases when its vent terminal is exposed to the effects of winds having nominal velocities from zero to 31 miles per hour (13.86 m/s) [0.40 inch water column (100 Pa)].

Method of Test

This test shall be conducted at normal inlet test pressure.

Burner and primary air adjustments shall be made in accordance with 2.5.4.

a. The furnace shall be operated until a constant flue gas temperature has been attained. The test method specified in 2.33.2a shall be applied when testing with wind directed other than perpendicular to the wall, except that the wind produced by the blower shall be varied to have nominal velocities from zero to 31 miles per hour (13.86 m/s) [0.40 inch water column (100 Pa) velocity pressure measured with a pitot tube] at the vent terminal. During the application of this range of wind velocities, sufficient flue gas samples shall be secured and analyzed to determine that the carbon monoxide concentration does not exceed 0.04 percent in an air-free sample of the flue gases.

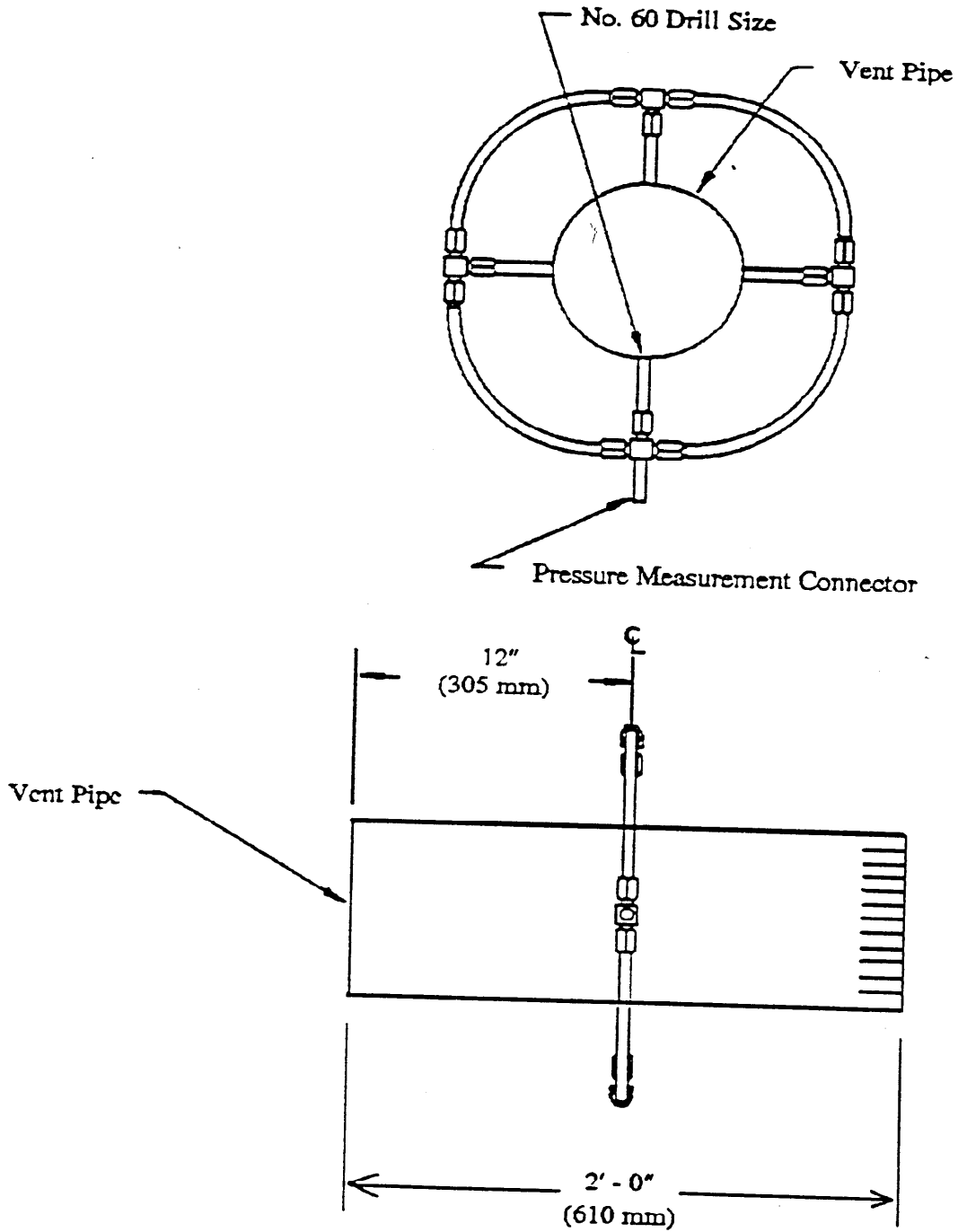

Figure 3.
Piezo Ring
and
Details of Typical Construction
3

At the discretion of the testing agency, additional tests may be conducted with winds of the same velocities directed from various directions.

b. The furnace shall be operated until a constant flue gas temperature has been attained. The test method specified in 2.33.2-b, shall be applied, except that the vent pressure shall be varied from zero to 0.40 inch water column (100 Pa). During the application of this range of vent pressure, sufficient flue gas samples shall be secured and analyzed to determine that the carbon monoxide concentration does not exceed 0.04 percent in an air-free sample of a the flue gases.

2.33.4 The operating characteristics of a furnace shall not be affected by the wind conditions specified in 2.33.3.

This provision shall be deemed met when the variation in the carbon dioxide concentration in the flue gases is not in excess of the limit specified in the following Method of Test.

Method of Test

2.5.4. Burner and primary air adjustments shall be made in accordance with 2.5.4.

The furnace shall be operated under a still air condition at normal inlet test pressure until a constant flue gas temperature is attained. A flue gas sample shall then be secured and analyzed for carbon dioxide.

The conditions specified in 2.33.3 shall then be imposed on the vent terminal and sufficient flue gas samples secured and analyzed under the various conditions to determine the carbon dioxide concentration.

The carbon dioxide concentration with the furnace subjected to any of the conditions specified in 2.33.3 shall not be less than 50 percent of the carbon dioxide concentration produced by the furnace when operated at normal inlet test pressure under a still air condition.

At the discretion of the testing agency, additional tests may be conducted with winds of the same velocities directed from other directions as specified in 2.33.3-a.

December 8, 1992

TO: MANUFACTURERS OF CERTIFIED FURNACES AND BOILERS

SUBJECT: UP-DATE OF THE INTERIM WIND TEST PROTOCOL

With my letter of October 21st I supplied an Interim Wind Test Protocol for evaluating side wall vented, mid-efficiency gas furnaces and boilers. Please note, the wind protocol is not restricted to "mid-efficiency" furnaces and boilers but is intended for "all" side wall vented furnaces and boilers with the exception of Direct Vent Types only.

On November 4th and 5th, the Harmonized Furnace Technical Working Group met to solidify the wind test procedures for furnaces. In that meeting a correction was made to the velocity pressure of 0.40 inch water column representing 31 miles per hour (13.86 mls) wind velocity. The correct pressure is 0.47 inch water column. The effective vent static pressure remains at 0.40 inch water column.

Also, the working group has revised coverage for "Direct Vent Furnaces" and "Central Furnaces for Outdoor Installation". On February 2nd, 3rd and 4, 1992 the Harmonized Central Furnace Subcommittee will be meeting to accept the new wind test procedures. If they do, we will immediately adopt the new procedures for certification purposes with the following understandings:

1. All new furnace and boiler designs submitted to A.G.A. Laboratories for certification that require wind test will be tested to the new wind test procedure.
2. Certified product that changes design affecting the vent system design or new design that might be affected by wind testing will be tested to the new wind procedure.
3. I am proposing an effective date for the new wind test procedure to be 18 months from the date of approval by the American National Standards Institute, Inc. Any certified product which has not been tested to the new procedure by that date will be called in for test.

If you have any comments or questions to this interim wind test procedure or the effective date, please plan to address them at the February 2nd, 3rd and 4th Furnace Subcommittee meeting in Cleveland, Ohio.

Sincerely yours,



SPENCER P. GRIECO
Laboratories Vice President
Product Certification

ITEM 15.
Z21/CGA Joint Water Heater
Subcommittee Meeting,
September 23-24, 1993

**REVIEW COMMENTS REGARDING WHETHER THE REFERENCE
TO NSF STANDARD 14 IN Z21.10.1 IS APPROPRIATE**

Action Requested

1. Review comments regarding whether the reference to National Sanitation Foundation (NSF) Standard 14 is the applicable standard to reference under 1.14.2, Dip Tubes, in Z21.10.1; and
2. Verify if the above referenced standard is the intended standard, and if not, revise 1.14.2 in Z21.10.1 accordingly.

Background

Attached is an August 19, 1992 letter to Mr. Bobby Crawford, American Gas Association Laboratories (AGAL), from Mr. William Slattery, Apcom, Inc. (*See Attachment I.*) In his August 19 letter, Mr. Slattery indicated that an error exists in the *A.G.A. Requirements for Nonmetallic Dip Tubes For Use In Gas-fired Water Heaters*, No. 1-89. Mr. Slattery noted that Mr. Don Wudarski of the NSF had indicated that the NSF 61 Standard is the correct reference, rather than NSF 14.

Also attached is a September 28, 1992 response letter from Mr. Crawford to Mr. Slattery. (*See Attachment II.*) In his response, Mr. Crawford noted that the A.G.A. Requirement 1-89's reference to NSF 14 is consistent with coverage under 1.14.2 in Z21.10.1-1990.

Additional Background

Attached are excerpts from the Scope of NSF Standard 14 and NSF Standard 61. (*See Attachment III.*) The NSF 14 excerpt indicates that it was adopted by NSF in October 1965, and has been revised since 1977. In addition, the NSF 61 excerpt indicates that it is a relatively new standard, adopted by NSF in June 1988 and revised in October 1988.

History of NSF 14 Reference
in Z21 Water Heater Standards

At its November 16-17, 1977 meeting, the Z21 water heater subcommittee was informed that the Technical Committee of the Gas Appliance Manufacturers Association's (GAMA) Water Heater Division had determined there are applicable standards which

(15-1)

(b) CLEARER: 3/13/95
 No Edits Identified
Edits Made
NSF 14/61
Comments Forwarded

could be referenced in the construction provisions of the water heater standards covering nonmetallic dip tubes. The GAMA technical committee recommended that the NSF Standard 14 be referenced under the dip tube section of Z21.10.1. The subcommittee concurred with this and recommended a clarification of Z21.10.1 to the Z21 Committee. Similar modifications were also recommended for the Z21.10.3 and Z21.56 standards, respectively. The reference to NSF 14 was added as worded below, which is excerpted from 1.14.3 in Z21.10.1b-1979:

"Evidence of current certification under National Sanitation Foundation Standard 14 for potable water (NSF-PW) with appropriate end use shall be deemed acceptable."

Subsequently, the NSF 14 reference was editorially revised as shown below from 1.14.3 in Z21.10.1-1984:

"Evidence of current certification under National Sanitation Foundation Standard 14 for Plastic Piping System, Components and Related Materials with appropriate end use shall be deemed acceptable."

A search of past subcommittee meeting minutes did not indicate any record of discussion on revising the title of the NSF 14 reference in the 1984 edition. The above reference has not been revised since.

APCOM Inc.

Southeast Parkway
P. O. Box 687
Franklin, Tennessee 37065-0687
(615) 794-5574 • FAX (615) 791-0660

American Gas Association
8501 East Pleasant Valley Road
Cleveland, OH 44131

August 19, 1992

attn: Bobby Crawford
re: AGA Requirements for Nonmetallic Dip Tubes for use in Gas-Fired Water Heaters No. 1-89
September 6, 1989

Dear Mr. Crawford

I wish to draw reference to an error in the above mentioned standard. Reference Part I, Sect. 1.3.2, para. 2;

Evidence of current certification under National Sanitation Foundation Standard 14 for Plastic Piping System, Components and Related Materials with appropriate end-use shall be deemed acceptable.

Should read: 61 - 1991, Drinking Water System Components - Health Effects

This writer, after conversing with Don Wudarski at NSF in Atlanta, GA., noted this while researching certification requirements. Mr. Wudarski states that the nonmetallic dip tube is under the 61 std rather than the 14 std. This was related to George Atoulikian who directed me to write this matter to your attention.

I will look forward to your findings as to this matter.

Sincerely,

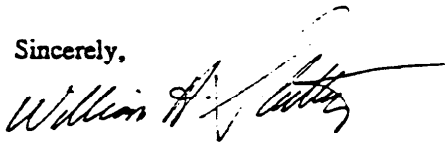

William H. Slattery
Product Engineer

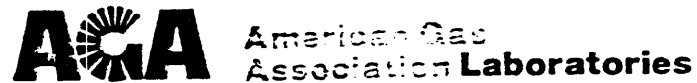

8501 East Pleasant
TELEX 260574 AGA
Tenn

September 28, 1992

Mr. William H. Slattery
Product Engineer
APCOM, Inc.
Southeast Parkway
P.O. Box 687
Franklin, Tennessee 37065-0687

Subject: A.G.A. Requirements For Nonmetallic Dip Tubes For Use In
Gas-Fired Water Heaters, No. 1-89

Dear Mr. Slattery:

Thank you for your letter of August 19, 1992 regarding the reference to NSF Standard 14 in A.G.A. Requirement No. 1-89.

The reference to NSF Standard 14 is consistent with the current ANSI standard for gas water heaters, ANSI Z21.10.1-1990, which has the identical reference on page 12 under paragraph 1.14.2.

We are in the process of confirming the proper reference with NSF. Based on our findings, we will make appropriate recommendations to the Z21 water heater subcommittee and corresponding revisions, if required, to A.G.A. 1-89.

Thanks again for calling this matter to our attention.

Very Truly Yours,

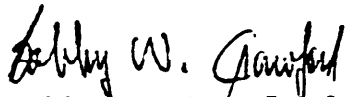
Bobby W. Crawford
Manager
Advanced Technology

cc: G. Atoulikian
A. Callahan
S. Grieco
G. Gruss
T. Perera

NATIONAL SANITATION FOUNDATION
STANDARD 14
FOR
PLASTICS PIPING SYSTEM COMPONENTS AND RELATED
MATERIALS

As Prepared by
The NSF Joint Committee
on
Plastics
and
Recommended for Adoption
by
The NSF Council of Public Health Consultants
Adopted
by
The NSF Board of Trustees
October 1965

Revised February 1977
Revised November 1978
Revised November 1980
Revised November 1983
Revised November 1984
Revised November 1985
Revised August 1986
Revised October 1987
Revised December 1988

National Sanitation Foundation
3475 Plymouth Road
P. O. Box 1468
Ann Arbor, Michigan 48106 USA

**NSF STANDARD 14
FOR
PLASTICS PIPING SYSTEM COMPONENTS AND RELATED MATERIALS**

SECTION 1. GENERAL

- 1.0 **SCOPE:** This standard covers thermoplastic and thermoset plastics piping system components (pipe, fittings, valves, joining materials, appurtenances, etc.). It also covers ingredients and materials used to fabricate components and plastics coatings. It provides definitions and requirements for ingredients, materials, products, quality assurance, marking, and record keeping. These are covered in separate sections of this standard. All sections need to be examined to determine the total requirements for a specific product. This standard includes minimum requirements for plastics piping system components and related materials.
- 1.1 **MINIMUM REQUIREMENTS:** Variations from these minimum requirements may be permitted when they provide products suitable for the intended end use. Units with components covered under other NSF standards or criteria shall comply with those applicable requirements.
- 1.2 **STANDARD REVIEW:** A complete review of this standard shall be conducted at least every five years. These reviews shall be conducted by representatives from industry, public health, and user groups of the NSF Joint Committee on Plastics.

SECTION 2. DEFINITIONS

- 2.0 **APPURTENANCES:** Accessories of a plastics piping system designed for special applications or end uses. Appurtenances may include, but not be limited to pipe, fittings, valves, storage tanks, tank liners, special coatings, faucet parts, and riser assemblies.
- 2.1 **BOND:** The union of materials.
- 2.2 **BUILDING DRAIN:** The lowest part of a drainage piping system receiving discharge from soil, waste, and other drainage pipe inside the building. It conveys these wastes to the building sewer, beginning 3 feet (0.9 m) outside the building wall.
- 2.3 **BUILDING SEWER:** The portion of horizontal piping of a drainage system extending from the end of the building drain, receiving discharge of the building drain. It conveys the discharge to a public or private sewer, individual sewage disposal system, or other point of disposal.
- 2.4 **CALCIUM CARBONATE:** An ingredient obtained by crushing or grinding limestone or precipitating calcium carbonate, that may be modified by the application of calcium stearate or stearic acid to improve dispersion characteristics.
- 2.5 **CALCIUM STEARATE:** An ingredient consisting of calcium with a mixture of solid organic acids obtained from fats.

NATIONAL SANITATION FOUNDATION
STANDARD 61
FOR
DRINKING WATER SYSTEM COMPONENTS - HEALTH EFFECTS

As Prepared By
The NSF Joint Committee
on
Drinking Water Additives
and
Recommended for Adoption
by the NSF Council of Public Health Consultants

Adopted
by
The NSF Board of Trustees
June 1988
Revised October 1988

Copyright© 1988
National Sanitation Foundation
3475 Plymouth Road
P.O. Box 1468
Ann Arbor, Michigan 48106 USA

Phone: 313/769-8010
FAX: 313/769-0109
Telex: 753215

NSF STANDARD 61 FOR
DRINKING WATER SYSTEM COMPONENTS -
HEALTH EFFECTS

SECTION 1. GENERAL

- 1.0 SCOPE: This standard is intended to cover specific materials or products that come into contact with drinking water and/or in contact with drinking water treatment chemicals. The primary focus of the standard is on contaminants or impurities which may be imparted indirectly to drinking water. The products and/or materials covered include, but are not limited to process media (carbon, sand, etc.), protective materials (coatings, linings, liners, etc.), joining and sealing materials (solvent cements, welding materials, gaskets, etc.), pipes and related products (Pipes, tanks, fittings, etc.), and mechanical devices used in treatment/transmission/distribution systems (valves, chlorinators, separation membranes, etc.).
- 1.1 LIMITATIONS: The requirements of this standard are limited to addressing potential health effects, except where specific application and/or performance standards are referenced. The criteria set forth in this standard cover products produced by good manufacturing practices and generally recognized manufacturing processes. As the presence of unusual or unexpected impurities may be dependent upon the method of manufacture and the quality of raw material used, products prepared by other than recognized methods of manufacture or with unusual raw materials shall be fully evaluated in accordance with Section 3.0 of this standard (general requirements). Products that have been evaluated and found to meet other NSF standards having requirements equivalent to this standard, may be acceptable for drinking water applications without separate evaluation under this standard.¹
- Units with components or parts covered under other NSF Standards or Criteria, shall comply with those applicable requirements.
- 1.2 ALTERNATE MATERIALS: Where specific materials are mentioned in this standard, it is understood that the use of alternate materials will be acceptable provided they are evaluated and determined to be satisfactory. Products using specific materials not named in the appropriate section of this standard shall have these unnamed materials evaluated in a manner consistent with the appropriate requirements for these materials.
- 1.3 STANDARD REVIEW: A complete review of this standard shall be conducted at least every five (5) years to keep requirements consistent with new technology. These reviews shall be conducted by representatives of industry, public health, and users on the Joint Committee for Drinking Water Additives.

¹Final acceptance of a product for drinking water application is the responsibility of the appropriate federal, state, and/or local regulatory agent.

ITEM 16.
Z21/CGA Joint Water Heater
Subcommittee Meeting,
September 23-24, 1993

**REVIEW THE TERM "READILY ACCESSIBLE" IN THE WATER HEATER
STANDARDS TO CLARIFY ITS INTENT AND PROPOSE A DEFINITION**

Action Requested

1. Review those provisions where the term "readily accessible" appears in the Z21 water heater standards (Z21.10.1, Z21.10.3 and Z21.56); and
2. Clarify the intent of the above term in each case and consider proposing a definition for the above term.

History

At its September 21-22, 1993 meeting, the joint subcommittee considered a suggestion under "Other Business" to clarify the term "readily accessible" in the water heater standards by adding an appropriate definition.

It was noted that the phrase "readily accessible" is defined in the National Fuel Gas Code (ANSI Z223.1/NFPA 54) as follows:

"Accessible, Readily. Having direct access without the need of removing or moving any panel, door, or similar covering of the item described."

In addition, it was pointed out that Z223.1 and the central furnace standard (ANSI Z21.47-1990) both contain the following definition:

"Accessible. Having access to, but which first may require the removal of a panel, door or similar covering of the item described."

It was noted that in many provisions of the water heater standards, the phrase "readily accessible" is not intended to be interpreted as complying with the Z223.1 definition. This possible conflict may become apparent during a testing agency's evaluation of a gas control location on an appliance, in which the control must be accessed by removing or moving a panel or door. If a testing agency interprets the water heater standards' term "readily accessible" as defined in Z223.1, it may deem the appliance not in compliance with the water heater standards. Therefore, the subcommittee was requested to clarify this matter.

(16-1)

④b) CLEARED: 3/13/95
✓ No Info Identified

Comments Processed

During discussion, it was suggested that the subcommittee adopt the central furnace standard's definition for "accessible," and delete the term "readily" from the phrase "readily accessible," wherever it appears in the water heater standards. However, it was noted that in some provisions, it would not be appropriate to delete the term "readily" from this phrase.

Chairman Hosler commented that it would not be prudent to delete the term "readily," without first conducting a case-by-case review of each provision containing the term "readily accessible."

The subcommittee requested staff to develop an agenda item for its next meeting on this subject, reproducing all water heater standards' provisions where the phrase "readily accessible" is found. It was acknowledged that if the subcommittee agrees to retain the phrase in some provisions, there may be a need to add a definition for "readily accessible."

Z21 Water Heater Standards Coverage

Attached are excerpts from the Z21 water heater standards showing the provisions where the term "readily accessible" appears. (*See Attachment I.*)

In addition, attached for the subcommittee's information are excerpts from the Z21 water heater standards showing the provisions where the term "accessible" appears. (*See Attachment II.*)

Additional Coverage Related to Accessibility

For the subcommittee's information, the following is an excerpt from newly added coverage which will appear in ANSI Z21.10.1-1993, Z21.10.3-1993, and Z21.56a-1993:

"1.11 AUTOMATIC GAS IGNITION SYSTEMS

"1.11.13 When a piezo-electric spark device is provided, the means to activate the spark generator shall be located so as to be easily operated or, if concealed in normal operation, shall be capable of being reached by the simple removal of an access cover without the use of tools. The use of tools to remove the access cover of a water *[pool]* heater for outdoor installation shall be acceptable."

Excerpts from Z21.10.1-1990:

STAFF NOTE: The term "readily accessible" is shaded for ease of reference.

PART I

CONSTRUCTION

1.9 MAIN BURNER ORIFICES AND ORIFICE FITTINGS

1.9.1 Orifice fittings, except those used with multiple injection tube burners, shall be readily accessible for adjustment and replacement. In all cases, orifice fittings shall be securely positioned to prevent misalignment with the burner mixer.

STAFF NOTE: The above provision also appears in Z21.10.3 and Z21.56.

1.9.3 Threaded hexagon head or equivalent fixed orifice spuds shall be provided for the main burners of water heaters for installation in manufactured homes (mobile homes) and recreational vehicles convertible for use with natural gas or liquefied petroleum gases. They shall be readily accessible after the burner(s) and mixer tube(s) have been removed.

STAFF NOTE: Text similar to the above also appears in Z21.10.3 and Z21.56.

1.15 MANUALLY OPERATED GAS VALVES

1.15.2 A manual valve or pilot shutoff device for turning on and shutting off the gas supply to the pilot burner shall be provided and shall be located so as to be readily accessible.

STAFF NOTE: The above provision also appears in Z21.10.3 and Z21.56.

1.15.3 A water heater not for installation in a recreational vehicle shall have a manual gas shutoff valve provided in a readily accessible location for turning on or shutting off the gas to the main burner(s).

STAFF NOTE: Text similar to the above also appears in Z21.10.3 and Z21.56.

1.15.4 A water heater for installation in a recreational vehicle shall have either:

- a. A manual gas shutoff valve provided in a readily accessible location for turning on or shutting off the gas to the main burner(s); or
- b. A readily accessible means at the appliance for manually interrupting the ungrounded leg of the electrical power to both appliance control valves if the appliance has a nominal 12 volt, or less, direct current (d.c.) direct ignition system and two solenoid valves for controlling main burner gas flow.

STAFF NOTE: The above provision is exclusive to Z21.10.1.

1.15.8 Gas burner valves shall be readily accessible for repair and adjustment.

STAFF NOTE: The above provision also appears in Z21.10.3 and Z21.56.

1.16 GAS APPLIANCE PRESSURE REGULATORS

1.16.4 Gas appliance pressure regulators shall be readily accessible for servicing and replacement.

STAFF NOTE: The above provision also appears in Z21.10.3 and Z21.56.

1.17 ADJUSTMENT OF MINIMUM INPUT RATING

Any field adjustment means on controls designed for two or more rates shall be readily accessible and leakproof. Controls not equipped with field adjustment means shall be set by the manufacturer so the low-flow condition is not lower than the manufacturer's specified minimum input rating.

STAFF NOTE: The above provision also appears in Z21.10.3 and Z21.56.

1.18 THERMOSTATS

Thermostats, when provided, shall be readily accessible for servicing or replacement and shall comply with the applicable construction provisions of the Standard for Gas Appliance Thermostats, ANSI Z21.23.

STAFF NOTE: The above provision also appears in Z21.10.3. However, the Z21.56 pool heater standard does not require "readily accessible" thermostats or operating controls, as follows:

"1.17.2 Thermostats shall be accessible for servicing or replacement and shall comply with the applicable construction provisions of the Standard for Gas Appliance Thermostats, ANSI Z21.23."

"1.17.5 Operating controls shall be accessible for servicing and replacement."

1.19 AUTOMATIC VALVES

Automatic valves, when provided, shall be readily accessible for servicing and replacement and shall comply with the applicable construction provisions of the Standard for Automatic Valves for Gas Appliances, ANSI Z21.21.

STAFF NOTE: Text similar to the above also appears in Z21.10.3 and Z21.56, which includes safety shutoff valves, in addition to automatic valves.

1.21 AUTOMATIC GAS SHUTOFF SYSTEMS

1.21.1 Each water heater shall be provided with an automatic gas shutoff system actuated by high water temperature as an integral part of the appliance. The automatic gas shutoff system shall be readily accessible for servicing or replacement and shall incorporate an automatic gas shutoff device which complies with the applicable construction provisions of the Standard for Relief Valves and Automatic Gas Shutoff Devices for Hot Water Supply Systems, ANSI Z21.22.

STAFF NOTE: Text similar to the above also appears in Z21.10.3 and Z21.56.

1.22 RELIEF VALVES

1.22.2 When relief valves to prevent excessive water pressure, temperature or vacuum are provided, they shall be readily accessible for servicing or replacement, and shall comply with the applicable construction provisions of the Standard for Relief Valves and Automatic Gas Shutoff Devices for Hot Water Supply Systems, ANSI Z21.22.

STAFF NOTE: Text similar to the above also appears in Z21.10.3 and Z21.56.

Excerpts from Z21.10.1-1990:

STAFF NOTE: The term "accessible" is shaded for ease of reference.

PART I

CONSTRUCTION

1.2 GENERAL CONSTRUCTION AND ASSEMBLY

1.2.11 Storage vessels shall be equipped with a drain valve to facilitate emptying the tank for cleaning or withdrawing small quantities of water to eliminate foreign deposits. Drain valves on counter-type water heaters shall be **accessible** from the front of the appliance.

STAFF NOTE: The above provision is exclusive to Z21.10.1.

1.8 PRIMARY AIR ADJUSTMENT MEANS

1.8.4 Means shall be provided to secure air shutters in any desired position. Such means shall be **conveniently accessible** for adjustment with the burner(s) in place and the water heater in operation and shall be located so as not to interfere with adjustment of orifice caps when used.

STAFF NOTE: Text similar to the above also appears in Z21.10.3 and Z21.56.

1.10 AUTOMATIC GAS IGNITION SYSTEMS

1.10.6 Fixed primary air openings on blue flame pilots shall be of a size that will give a satisfactory flame when using the manufacturer's recommended orifice size for each of the test gases. Otherwise, blue flame pilots shall be equipped with **fully accessible** adjustable primary air control devices with adequate means for holding them in the desired adjustment position.

STAFF NOTE: Text similar to the above also appears in Z21.10.3 and Z21.56.

1.10.14 Pilot orifice adjustment means shall be fully accessible for adjustment and servicing. When a fixed orifice is used, the orifice spud shall be easily accessible for removal and replacement.

STAFF NOTE: Text similar to the above also appears in Z21.10.3 and Z21.56.

1.21 AUTOMATIC GAS SHUTOFF SYSTEMS

1.21.8 Functional parts of automatic gas shutoff devices shall be accessible for servicing and replacement without disconnecting the water lines or removing the water heater casing. Raising of the appliance top for the purpose of such accessibility or replacement is acceptable under this provision.

STAFF NOTE: Text similar to the above also appears in Z21.10.3 and Z21.56.

1.28 ELECTRICAL EQUIPMENT AND WIRING

1.28.9 Splices in wiring shall be located only in accessible junction boxes. Splices shall be made mechanically secure, soldered, and suitably insulated with tape, or suitable fixture-type splicing connectors shall be employed. Provision shall be made to prevent accidental mechanical strain on splicing devices. (Strain relief is not necessary when wiring is done in conduit, metal-clad cable or raceways.)

STAFF NOTE: Text similar to the above also appears in Z21.10.3 and Z21.56.

1.31 MARKING

1.31.26 ELECTRICAL DIAGRAMS.

- e. The electrical diagrams specified in "a" above shall be attached to the appliance in a location where they are accessible during servicing of the electrical components. Some means of color, letter or number coding corresponding to the appliance wiring shall be used in the diagrams to facilitate circuit identification.

STAFF NOTE: Text similar to the above also appears in Z21.10.3 and Z21.56.

Excerpts from Z21.10.3-1990:

STAFF NOTE: The term "accessible" is shaded for ease of reference.

PART I

CONSTRUCTION

1.2 GENERAL CONSTRUCTION AND ASSEMBLY

1.2.7 Heating surfaces shall be securely fastened in position and shall be **accessible** for cleaning without major dismantling. Disconnection of the flue or vent connector and draft hood, the water, gas and low-voltage electrical supply, or removal of the top of the water heater, shall be considered as complying with this provision.

STAFF NOTE: The above provision also appears in Z21.56.

1.10 AUTOMATIC GAS IGNITION SYSTEMS

1.10.14 Pilot gas flow adjustment means shall be **fully accessible** for adjustment and servicing.

STAFF NOTE: The above provision also appears in Z21.56.



ITEM 17.
Z21/CGA Joint Water Heater
Subcommittee Meeting,
September 23-24, 1993

**CGRI RESEARCH TO STUDY THE RELEASE OF
COMBUSTION PRODUCTS FROM SIDEWALL-VENTED
APPLIANCES INTO THE INDOOR ENVIRONMENT**

Action Requested

Review information regarding Canadian Gas Research Institute's experimental study of release of combustion products from sidewall vented appliances into the indoor environment.

Background

Attached is a copy of a November 24, 1992 letter from Mr. Ed Farkas, Canadian Gas Research Institute (CGRI), to Mr. Ken Bales, Canadian Gas Association, informing him of CGRI's experimental study of release of combustion products from side-wall vented appliances into the indoor environment. Mr. Farkas indicated that CGRI feels that the results of the study would be of interest to various CGA committees, and would be prepared to present information to appropriate committees, receive input from them during the course of the work, and after it is completed.

Mr. Ken Bales requested that the attached November 1992 letter from CGRI be presented to the appropriate Z21/CGA joint subcommittees.

Additional Background

A copy of the CGRI report is attached.

results indicate that there is no need to develop a test for depressure. i.e. 50% no leakage back into house

✓ (b) CLEARED: 3/13/95
No info identified
[Signature]



**CANADIAN GAS RESEARCH INSTITUTE
INSTITUT CANADIEN DES RECHERCHES GAZIERES**

55 Scarsdale Road, Don Mills, Ontario M3B 2R3 • Tel: (416) 447-8465 • Fax: (416) 447-6757

November 24, 1992

to: Ken Bales

from: Ed Farkas

At the request of our member organizations, we are currently carrying out an experimental study of release of combustion products from sidewall-vented appliances into the indoor environment.

Rate of release will be measured for representative appliances, for zero depressurization and for varying degrees of depressurization.

The cost of the work is being shared between the CGRI core program and the Industrial Research Assistance Program (IRAP) which is part of National Research Council. The Canadian Home Builders' Association assisted in putting the IRAP financial support in place. Funding for the CGRI core program comes from the CGRI member organizations.

We believe the results of the work will be of interest to various CGA committees. We are prepared to present information to appropriate CGA committees, and receive input from them, during the course of the work, and after it is completed.

I should amplify the first paragraph above by noting that the equipment to be examined in each case consists of the appliance and its venting system.

RESISTANCE OF SIDE-WALL VENTED APPLIANCES
TO COMBUSTION PRODUCT LEAKAGE
WHEN OPERATING WITHIN
DEPRESSURIZED STRUCTURES

59-108

R. D. LaFONTAINE, C.E.T.

H. PATEL, C.E.T.

MAY, 1993

(15) ~~CLEARER~~: 3/13/95
✓ No title identified

Comments Processed

TABLE OF CONTENTS

LIST OF TABLES	iii
LIST OF FIGURES	iv
ACKNOWLEDGEMENTS	v
SUMMARY	vi
1. INTRODUCTION	1
2. TEST FACILITY	2
2.1 Depressurization Chamber	2
2.2 Measurement Instrumentation	3
2.3 Instrumentation Sensitivity	3
3. CHAMBER INSTALLATION OF THE APPLIANCE	4
4. REQUIRED TEST MEASUREMENT DATA	6
4.1 Chamber Depressurization Level	6
4.2 Appliance Input Rate and Vent CO ₂ Concentration	6
4.3 Appliance Combustion Gases CO ₂ Concentration	6
4.4 Chamber Atmosphere and Background CO ₂ Concentrations	7
4.5 Standing Pilot Burner Input Rate	7
4.6 Auxiliary Blower Tracer Gas Concentration	7
5. LEAKAGE SOURCES IDENTIFICATION AND CORRECTIVE MEASURES	8
6. PROPOSED TEST AND CALCULATION PROCEDURE	8
7. VALIDATION OF TEST METHODOLOGY	11
8. TEST PROGRAM DATA PRESENTATION	11
8.1 Appliance #1	12
8.2 Appliance #2	12
8.3 Appliance #3	13
8.4 Appliance #4	13
8.5 Appliance #5	13
8.6 Appliance #6	14
8.7 Appliance #7	14
8.8 Appliance #8	14
8.9 Appliance #9	15
8.10 Appliance #10	15
8.11 Hybrid Test Results	15
CONCLUSIONS	17
RECOMMENDATIONS	19
REFERENCES	20

LIST OF TABLES

TABLE	TITLE	PAGE
1	Data Summary - Appliance #1	21
2	Data Summary - Appliance #2	22
3	Data Summary - Appliance #3	23
4	Data Summary - Appliance #4	24
5	Data Summary - Appliance #5	25
6	Data Summary - Appliance #6	26
7	Data Summary - Appliance #7	27
8	Data Summary - Appliance #8	28
9	Data Summary - Appliance #9	29
10	Data Summary - Appliance #10	30

LIST OF FIGURES

FIGURE	TITLE	PAGE
1	CO ₂ Leakage VS Chamber Depressurization Appliances #1 Through #5	31
2	CO ₂ Leakage VS Chamber Depressurization Appliances #6, #7, #9 and #10	32
3	CO ₂ Leakage VS Chamber Depressurization Appliance #8	33

ACKNOWLEDGEMENTS

This project was conducted as a component of the CGRI core program funded by Gas Technology Canada (GTC) with additional financial support from the Industrial Research Assistance Program (IRAP) of the National Research Council of Canada. Appreciation is extended to IRAP for this support and to the Canadian Home Builders Association (CHBA) for assisting in putting the financial arrangements in place.

SUMMARY

This project investigated a test procedure for determining combustion products leakage characteristics of side-wall vented gas-fired appliances under chamber depressurization levels up to 50 Pa. (0.20 inches water column). A total of ten appliances were processed through the test procedure. The appliances included four water heaters, two furnaces, two fireplaces, and two clothes dryers.

The test procedure was shown to be capable of 92% to 95% accuracy which was dependent on the requirement for supplementary chamber exhausting to obtain the desired depressurization value. A strong dependency on instrumentation sensitivity was indicated, especially at low contaminant concentrations.

Combustion product leakage quantification indicated very low leakage except for one water heater and one furnace. Minor remedial sealing of identified leakage sources on these particular appliances reduced leakage by 18% and 94% respectively, bringing these appliances more in line with the other eight appliances.

The very low leakage rates determined in this investigation do not support this type of test procedure being made a mandatory certification requirement for these types of appliances.

1. INTRODUCTION

This project addressed a request for a validated program to assess, in a systematic and quantitative manner, the issue of combustion product leakage from gas-fired appliances into the indoor environment under depressurization conditions. The scope of this investigation was limited to sidewall-vented appliances under conditions of depressurization ranging up to 50 Pa (0.20 inches water column). Leakage of combustion products was to be investigated in relation to the degree of depressurization at the location of the appliance.

This project was prompted by an initiative from the Canadian Gas Association in response to a request for guidance, in identifying appliances susceptible to leakage, from the Canadian Standards Association F326 Technical Committee on Residential Mechanical Ventilation Systems.

The two specific objectives of the project were:

- To develop and validate a laboratory test method and, if possible, a field-applicable method for determining the extent of combustion product leakage from appliances of concern in this project. These methods could be used for testing and development purposes by manufacturers, certification agencies and, if possible, field personnel.
- To provide quantitative information on the extent of leakage from representative appliances for use by Standards setting bodies and regulatory agencies.

A total of ten appliances were evaluated using the test protocol developed in this project. The appliances included four water heaters, two furnaces, two fireplaces, and two clothes dryers.

2. TEST FACILITY

2.1 Depressurization Chamber

In order to establish the required conditions, it was necessary to contain the appliance in a structure which could be evacuated to generate a desired level of depressurization. In order to quantify any resultant leakage of combustion products, it was necessary to contain those gases in a dynamic system and accurately measure *all* exfiltration from the chamber. Omission of any unmeasured exfiltration would result in a smaller quantity of combustion product leakage being determined in the calculation procedure.

An existing chamber in the CGRI Laboratory measuring nominally eight feet cubed was utilized in this project to contain an individual appliance under investigation. The internal volume was halved for this project by installing a partition wall in order to accelerate the establishment of steady state pollutant concentration conditions inside the structure. The structure was made as air tight as reasonably possible in order to minimize the quantity of exfiltration necessary to reduce the internal ambient pressure to the desired level. The air tightness of the test facility will determine whether the appliance alone can generate the levels of depressurization desired or whether additional chamber exhausting would be required. An auxiliary exhaust blower was used to supplement appliance exhausting from the chamber when necessary. A circulating blower inside the chamber was utilized to promote homogeneous mixing within the structure, thereby minimizing stratification and

permitting point sampling of the interior atmosphere. Auxiliary cooling was provided by tandem air conditioning units for appliances discharging significant heat into the chamber.

2.2 Measurement Instrumentation

Carbon dioxide was used as the sole tracer gas in these test procedures. The choice of CO₂ as the tracer gas was based on the relatively high concentration of this gas in the combustion products of most appliances. Elimination of the injection of any other tracer gas was originally considered a benefit to the overall ease and accuracy of the procedure through simplification of methodology. Two infra-red CO₂ analyzers with ranges of 0 - 20% and 0 - 5,000 ppm were utilized in this study.

Nominal relationships between CO₂ and NO_x were determined for each appliance with the use of a chemiluminescence NO/NO_x analyzer with selective ranges from 10 ppm to 10,000 ppm full scale. The indoor air quality criteria for NO_x as opposed to CO₂ or water vapour may be the limiting factor in determining maximum leakage criteria for some appliances. The nominal NO_x to CO₂ ratio was applied to CO₂ determinations to estimate the respective NO_x pollutant emission.

2.3 Instrumentation Sensitivity

The high level CO₂ infra-red analyzer had a 20% full range and a digital display output sensitivity of 0.05 percentage points between 0 and 20% of full scale and 0.10 percentage points between 20% to 100% of full scale.

The low level CO₂ infra-red analyzer had a 5,000 ppm full range and a digital display output sensitivity of 10 ppm between 0 and 20% of full scale and 20 ppm between 20% to 100% of full scale.

The chemiluminescence NO_x analyzer had multiple ranges of 10 ppm to 10,000 ppm full scale and an analogue display output with a sensitivity of 0.5% of full scale.

Instruments were zeroed with nitrogen where appropriate and calibrated with certified span gas of appropriate range.

The flow tubes for tracer gas injection were used in conjunction with calibrated flow curves for CO₂ or appropriate correction factors. All tracer gas injection rates were corrected for temperature and pressure using a type K thermocouple and a 0-100 +/-2 inch water column magnehelic gauge. The bottled CO₂ was commercial grade (min 99.5%).

3. CHAMBER INSTALLATION OF THE APPLIANCE

All appliance installations used the maximum recommended equivalent length of venting prescribed by their individual installation instructions. This was intended to place the appliance in a worst case situation by imposing the highest flow resistance on its vent system which would result in the highest CO₂ concentration in its vent gases. Typically, the change in CO₂ concentration between minimum and maximum equivalent vent lengths is not very significant but would affect the final determinations and was, therefore, standardized in this fashion. The assembly of the vent and sealing of joints and/or seams were carried out as prescribed by the individual appliance manufacturer's instructions.