

ERK

# NISTIR 5950

---

---

## Study of Technology for Detecting Pre-Ignition Conditions of Cooking-Related Fires Associated with Electric and Gas Ranges and Cooktops, Final Report

---

---

Erik L. Johnsson

Building and Fire Research Laboratory  
Gaithersburg, Maryland 20899

# NIST

United States Department of Commerce  
Technology Administration  
National Institute of Standards and Technology

CPSA ~~§~~ (b)(1) Cleared

*[Signature]*  
No Mfrs/PrvtLbrs or

Products Identified

Excepted by \_\_\_\_\_  
Firms Notified

---

---

**Study of Technology for Detecting Pre-Ignition  
Conditions of Cooking-Related Fires Associated  
with Electric and Gas Ranges and Cooktops,  
Final Report**

---

---

Erik L. Johnsson

January 1998  
Building and Fire Research Laboratory  
National Institute of Standards and Technology  
Gaithersburg, MD 20899



CPSCA 6 (b)(1) Cleared  
2/6/98  
No Mfrs/Prvt. Ents. of  
Products Identified  
\_\_\_\_ Excepted by \_\_\_\_\_  
\_\_\_\_ Firms Notified,  
Comments Processed.

**U.S. Department of Commerce**  
William M. Daley, Secretary  
**Technology Administration**  
Gary R. Bachula, *Acting Under Secretary*  
for *Technology*  
National Institute of Standards and Technology  
Raymond G. Kammer, *Director*

*Prepared for:*  
**U. S. Consumer Product Safety Commission**  
Directorate for Engineering Sciences  
*Division of Electrical Engineering*  
Bethesda, MD 20814  
Contract No.: CPSC-IAG-95-1145

## Executive Summary

A significant portion of residential fires stem **from** kitchen cooking fires. Existing fire data indicate that these kitchen cooking fires primarily are unattended and most often involve oil or grease. Previous study has determined that strong indicators of impending ignition for several foods cooked on range surfaces are temperatures, smoke **particulates**, and hydrocarbon gases. The purpose of this experimental investigation was to determine the feasibility of utilizing one or more of these common characteristics of the pre-ignition environment as input to one or more sensor(s) in a pre-fire detection device. This device would detect approaching ignition and allow alarm or shutoff of the range for foods cooked on electric and gas ranges without generating false alarms during a variety of normal, or standard, cooking activities.

The aspect of feasibility explored by the National Institute of Standards and Technology was the physical possibility of differentiating between the characteristics of broad ranges of pre-ignition and normal environments. The ultimate goal of the overall study being conducted by the Consumer Product **Safety** Commission (CPSC) is to evaluate the overall feasibility of incorporating such a device into ranges that would react with alarm or shutdown to pre-ignition conditions and reduce the occurrence of unwanted kitchen fires without undue disruption of attended cooking. This evaluation of overall feasibility by the CPSC includes consideration of the reasonableness and magnitude of the social and economic costs and benefits in addition to the physical feasibility of a detection system.

In order to evaluate the physical feasibility of a pre-ignition range-fire detector, a substantial number of cooking procedures were examined. Simulations of unattended cooking leading to ignition as well as normal, or standard, cooking procedures that have the potential to mimic pre-ignition characteristics were included in the study. A total of 16 cases consisting of 5 normal, 5 unattended, and 6 that progressed from normal to unattended were tested on a typical electric range with an inactive range hood. To determine the effects of range type and hood status on sensor performance, two cases were repeated with the range hood active and three cases were repeated on a gas range. The total number of variations was 21, and each case was repeated once for a total of 42 tests.

A variety of measurements was made for each test. An aspirated sample probe was used to pump gases to carbon monoxide, carbon dioxide, and hydrocarbon analyzers. Thermocouples provided temperature measurements at locations near the food and in and around the range and range hood. Hydrocarbon-gas sensors of varying sensitivities to different types of hydrocarbon gases were placed on and around the range and range hood to enable evaluation of the response of potential detector components. Household photoelectric and ionization smoke detectors were placed around the room to evaluate the degree of false alarm incidence using these existing technologies.

The following conclusions are based on measurements and observations of combinations of specific ranges, pans, foods, and ventilation so extrapolation to other conditions should be made with caution.

- Measurements confirm that the cooking environment near the range during unattended cooking approaching ignition exhibits significantly higher levels of temperatures,

hydrocarbons, and **particulates** than the cooking environment produced by most normal, standard cooking procedures.

- Some attended, standard cooking procedures, such as blackening of fish, may produce conditions similar to those conditions approaching ignition because the procedures themselves are purposefully designed to use extreme temperatures.
- Several sensors positioned in certain locations offer high levels of differentiation when used alone. Depending on the setting of the threshold, a majority of cooking cases would appropriately cause alarm or not alarm.
- No single sensor performed faultlessly without the use of modifications of the detection system to account for special attended cooking cases, but one gas sensor on the range hood and a thermocouple contacting the bottom of the cooking pan were most effective.
- Standard household photoelectric and ionization smoke detectors identify pre-ignition conditions well, but generate a significant number of false alarms when used alone for the particular tests conducted.
- A limited effort at algebraically combining three sets of two sensor signals generates more robust differentiation, and for the best pair, pre-fire and normal conditions were clearly separated with the exception of one attended cooking case which would produce a false **alarm** rather than a failure to alarm.
- Results with impact on detection were insensitive to range type, range-hood status, and pan material.
- Based on the findings of this investigation, pre-fire detection systems for range-top cooking are physically feasible and merit further consideration.

## Acknowledgements

This work was sponsored by the U.S. Consumer Product Safety Commission with the support of the U. S. Fire Administration pursuant to Interagency Agreement No. **CPSC-IAG-95-1145**. Although they were developed in conjunction with CPSC staff, the materials presented here do not necessarily represent the views of the U.S. Consumer Product Safety Commission.

The author expresses appreciation to the Association of Home Appliance Manufacturers and Underwriters Laboratories for their cooperation and assistance and to the range manufacturers for their generous donation of ranges and helpful insights throughout the project.

The author wishes to acknowledge the hard work of Roy **McLane** and Marco Femandez in preparing and installing the sensors and other laboratory apparatus, Emil Braun in designing the electronics needed for the sensors and detectors, and Michelle King and Marco Femandez in conducting the experiments. The author also expresses appreciation to Laurean **DeLauter**, Gary Roadarmel, and others of the NIST Building 205 crew for their help with safety.

## Contents

<b>Executive Summary</b> .....	iii
Acknowledgements .....	v
Contents .....	vi
List of Figures .....	viii
<b>List of Tables</b> .....	<b>xi</b>
1.0 Introduction .....	1
1.1 <b>Review of Phase I</b> .....	1
1.2 Introduction to Phase II .....	2
2.0 Experimental .....	2
2.1 Gene&Design .....	2
2.1.1 Facility Construction .....	2
2.1.2 Kitchen Ranges and Range Hood .....	3
2.1.3 Test Case Cooking Procedures and Parameters .....	4
2.2 Instrumentation .....	9
2.2.1 Gas Analyzers. ....	9
2.2.2 Thermocouples .....	<b>17</b>
2.2.3 Laser-Attenuation and Scattering Apparatus .....	18
2.2.4 Video and Photographic Equipment .....	<b>18</b>
2.3 Sensors and Detectors .....	18
2.3.1 Gas Sensors .....	19
2.3.2 <b>Smoke Detectors</b> .....	22
2.4 General Procedure .....	22
2.5 Data Acquisition, Reduction, and Plotting .....	22
3.0 Results .....	25
3.1 General Experimental Results .....	25
<b>3.2 Gas Concentrations.</b> .....	25
3.3 Gas-Sensor Responses .....	27
3.4 Smoke-Detector Responses .....	27
3.5 Temperatures .....	27
3.5.1 <b>Pan and Food</b> .....	42
3.5.2 <b>Range and Range Hood</b> .....	42
3.6 Laser Attenuation and Scattering .....	42
3.7 Recorded Images .....	49

## Contents cont'd.

4.0 Analysis and Discussion .....	49
4.1 Analysis Techniques .....	49
4.2 Detection Potential of Devices .....	51
4.2.1 <b>Gas Sensors</b> .....	51
4.2.2 Thermocouples .....	69
4.2.3 Combinations of Sensors .....	73
4.2.4 Smoke Detectors .....	78
4.3 Effects of Cooking-Environment Variables .....	85
4.3.1 Food and Cooking Method .....	85
4.3.2 <b>Range Type</b> .....	89
4.3.3 Range-Hood Status .....	93
4.3.4 <b>Pan Material</b> .....	98
4.4 Reproducibility .....	98
4.4.1 Measurement Uncertainty .....	98
4.4.2 Consistency Between Phase I and II Results .....	101
4.4.3 Consistency Within Phase II Results .....	101
5.0 Summary and Conclusions .....	106
5.1 Summary .....	106
5.2 Conclusions .....	106
5.3 Suggestions for Future Work .....	108
6.0 References .....	109
7.0 Appendices .....	110
Appendix A. General Test Procedure .....	111
Appendix B. Sample Test Log Sheet .....	113
Appendix C. Data Analysis - Sample <b>Program Control</b> File .....	115

## List of Figures

Figure 1.	Categories of tests . . . . .	12
Figure 2.	Locations of near-range probes and thermocouples . . . . .	13
Figure 3.	Schematic of near-range configuration, instruments, sensors, and thermocouples . . . . .	15
Figure 4.	Locations of sensors and thermocouples away from the range . . . . .	16
Figure 5.	CO, hydrocarbon, and CO, concentrations versus time for french-fried potatoes in soybean oil ( <b>normal→unattended</b> ). . . . .	26
Figure 6.	CO, hydrocarbon, and CO, concentrations versus time for blackened <b>catfish</b> (normal) . . . . .	28
Figure 7.	Site 7 hydrocarbon-sensor responses versus time for french-fried potatoes in soybean oil ( <b>normal→unattended</b> ). . . . .	29
Figure 8.	Site 9 hydrocarbon-sensor responses versus time for french-fried potatoes in soybean oil ( <b>normal→unattended</b> ). . . . .	30
Figure 9.	Site 11 hydrocarbon-sensor responses versus time for french-fried potatoes in soybean oil ( <b>normal→unattended</b> ). . . . .	31
Figure 10.	Sites 7, 9, 11 water vapor and CO-sensor responses versus time for <b>french-fried</b> potatoes in soybean oil ( <b>normal→unattended</b> ). . . . .	32
Figure 11.	Site 9 hydrocarbon-sensor responses versus time for blackened catfish (normal) . . . . .	33
Figure 12.	Site 9 hydrocarbon-sensor responses versus time for chicken in <b>soybean</b> oil (unattended). . . . .	34
Figure 13.	All photoelectric detector alarm signals versus time for <b>french-fried</b> potatoes in soybean oil ( <b>normal→unattended</b> ). . . . .	35
Figure 14.	All ionization detector alarm signals versus time for french-fried potatoes in soybean oil ( <b>normal→unattended</b> ). . . . .	36
Figure 15.	All photoelectric detector alarm signals versus time for broiled steak ( <b>normal</b> ). . . . .	37
Figure 16.	All ionization detector alarm signals versus time for broiled steak (normal). . . . .	38
Figure 17.	Temperatures near the pan versus time for french-fried potatoes in soybean oil ( <b>normal→unattended</b> ). . . . .	39
Figure 18.	Temperatures near the pan versus time for blackened catfish (normal). . . . .	40
Figure 19.	Temperatures near the pan versus time for chicken in soybean oil (unattended). . . . .	41
Figure 20.	Temperatures of the range versus time for <b>french-fried</b> potatoes in soybean oil ( <b>normal→unattended</b> ). . . . .	43
Figure 21.	Temperatures above the range versus time for <b>french-fried</b> potatoes in soybean oil ( <b>normal→unattended</b> ). . . . .	44
Figure 22.	Temperatures of the range versus time for water and oil (normal+unattended) . . . . .	45



### List of Figures cont'd.

Figure 23.	Temperatures above the range versus time for water and oil (normal-, unattended). . . . .	46
Figure 24.	Laser attenuation versus time for french-fried potatoes in soybean oil ( <b>normal→unattended</b> ). . . . .	47
Figure 25.	Laser attenuation versus time for water and oil ( <b>normal→unattended</b> ). . . . .	48
Figure 26.	Pan-bottom temperature versus time for cooling-lag test of 500 mL oil on the type-A electric range. . . . .	50
Figure 27.	Site 6 total-cooking-gas sensor maximum normal and minimum ignition output 30 s before ignition versus test number. Data for the gas-range tests (35-38) are from the site 4 total-cooking-gas sensor. . . . .	52
Figure 28.	Site 9 carbon monoxide sensor maximum normal and minimum ignition output 30 s before ignition versus test number. . . . .	53
Figure 29.	Site 10 total-cooking-gas sensor maximum normal and minimum ignition output 30 s before ignition versus test number. Data for the gas-range tests (35-38) are from the site 8 total-cooking-gas sensor. . . . .	55
Figure 30.	Site 7 general-alcohol sensor maximum normal and minimum ignition output 30 s before ignition versus test number. . . . .	59
Figure 31.	Site 7 cooking-alcohol sensor maximum normal and minimum ignition output 30 s before ignition versus test number. . . . .	60
Figure 32.	Site 9 general-hydrocarbon sensor maximum normal and minimum ignition output 30 s before ignition versus test number. . . . .	61
Figure 33.	Site 9 general-alcohol sensor maximum normal and minimum ignition output 30 s before ignition versus test number. . . . .	62
Figure 34.	Site 9 total-cooking-gas sensor maximum normal and minimum ignition output 30 s before ignition versus test number. . . . .	63
Figure 35.	Site 9 cooking-alcohol sensor maximum normal and minimum ignition output 30 s before ignition versus test number. . . . .	64
Figure 36.	Site 11 general-hydrocarbon sensor maximum normal and minimum ignition output 30 s before ignition <b>versus</b> test number. . . . .	65
Figure 37.	Site 11 general-alcohol sensor maximum normal and minimum ignition output 30 s before ignition versus test number. . . . .	66
Figure 38.	Site 11 total-cooking-gas sensor maximum normal and minimum ignition output 30 s before ignition versus test number. . . . .	67
Figure 39.	Site 11 cooking-alcohol sensor maximum normal and minimum ignition output 30 s before ignition versus test number. . . . .	68
Figure 40.	Site 19 thermocouple temperature maximum-normal and minimum ignition output 30 s before ignition versus test number. . . . .	70
Figure 41.	Focus-burner pan-bottom temperature maximum normal and minimum ignition output 30 s before ignition versus test number. . . . .	71
Figure 42.	Focus-burner pan-bottom temperature maximum normal and minimum ignition output 60 s before ignition versus test number. . . . .	72

## List of Figures cont'd.

Figure 58.	Site 9 general-alcohol sensor response versus time before ignition for water and oil ( <b>normal→unattended</b> ) for the electric (A) range with the hood on and off. . . . .	94
Figure 59.	Site 9 general-alcohol sensor response versus time for broiled steak (normal) for the electric (A) range with the hood on and off. . . . .	95
Figure 60.	Site 9 general-alcohol sensor response versus time before ignition for chicken ( <b>normal→unattended</b> ) for the electric (A) range with the hood on and off. . . . .	96
Figure 61.	Site 9 general-alcohol sensor responses versus test number for water and oil ( <b>normal→unattended</b> ), broiled steak (normal), and chicken in oil ( <b>normal→unattended</b> ) for the electric (A) range with the hood on and off. . . . .	97
Figure 62.	Food temperature versus time before ignition for soybean oil (unattended) on the electric (A) ranges in aluminum and stainless-steel pans. . . . .	99
Figure 63.	Site 9 general-alcohol sensor response versus time before ignition for soybean oil (unattended) on the electric (A) ranges in aluminum and stainless-steel pans. . . . .	100
Figure 64.	Food temperature versus time before ignition for soybean oil (unattended) <b>on the electric (A) range for Phase I and Phase II.</b> . . . . .	102
Figure 65.	Laser attenuation versus time before ignition for soybean oil (unattended) <b>on the electric (A) range for Phase I and Phase II.</b> . . . . .	103
Figure 66.	Site 9 general-alcohol sensor maximum normal and minimum ignition output 30 s before ignition versus cooking case number for tests using the electric (A) range and inactive hood. . . . .	104
Figure 67.	Pan-bottom temperature maximum normal and minimum ignition output 30 s before ignition versus cooking case number for tests using the electric (A) range and inactive hood. . . . .	105
Figure 68.	Heating time to ignition versus cooking case number for tests using electric (A) range and inactive hood. . . . .	107

## List of Tables

Table 1.	Case description and procedure list . . . . .	5
Table 2.	Experimental test matrix . . . . .	10
Table 3.	Instrumentation list . . . . .	14
Table 4.	List of sensors . . . . .	20
Table 5.	Identification key for sensors and detectors . . . . .	21
Table 6.	Sensor and detector location descriptions . . . . .	23
Table 7.	Selected sensors' false-alarm and alarm-failure performance for 42 tests . .	56
Table 8.	Smoke detectors' false alarm and alarm failure performance for 42 tests . .	84

**List of Figures cont'd.**

Figure 43. Focus-burner pan-bottom temperature multiplied by site 7 general-alcohol sensor voltage maximum **normal** and minimum ignition output 30 s before ignition versus test number. # signifies results from substitute thermocouple data. . . . . 74

Figure 44. Focus-burner pan-bottom temperature multiplied by site 7 cooking-alcohol sensor voltage maximum normal and minimum ignition output 30 s before ignition versus test number. # signifies results **from** substitute thermocouple data. . . . . 75

Figure 45. Focus-burner pan-bottom temperature multiplied by site 9 cooking-alcohol sensor voltage maximum normal and minimum ignition output 30 s before ignition versus test number. # signifies results from substitute thermocouple data. . . . . 76

Figure 46. Focus-burner pan-bottom temperature multiplied by site 9 cooking-alcohol sensor voltage maximum normal and minimum ignition output 60 s before ignition versus test number. # signifies results from substitute thermocouple data. . . . . 77

Figure 47. Average photoelectric smoke-detector alarm time for all tests versus site number. . . . . 79

Figure 48. Sites 5-13 photoelectric smoke detectors ratio of alarm times to normal times for all tests versus test number. . . . . 80

Figure 49. Sites **5-13** photoelectric smoke detectors ratio of alarm times to ignition times for all tests versus test number. . . . . 81

Figure 50. Sites **14-17** photoelectric smoke detectors ratio of alarm times to normal times for all tests versus test number. . . . . 82

Figure 51. Sites **14-17** photoelectric smoke detectors ratio of alarm times to ignition times for all tests versus test number. . . . . 83

Figure 52. Average ionization smoke-detector alarm time for. all tests versus site number. . . . . 86

Figure 53. Sites **14-17** ionization smoke detectors **ratio** of alarm times to normal times for all tests versus test number. . . . . 87

Figure 54. Sites **14-17** ionization smoke detectors ratio of alarm times to ignition times for all tests versus test number. . . . . 88

Figure 55. Pan-bottom temperature versus time before ignition for chicken in oil (**normal→unattended**) for the electric (A) and gas (**B**) ranges. . . . . 90

Figure 56. Site **9** general-alcohol sensor response versus time before ignition for chicken in oil (**normal→unattended**) for the electric (A) and gas (**B**) ranges. . . . . \* . . . . \* . . . . \* 91

Figure 57. Laser attenuation versus time before ignition for chicken in oil (**normal+unattended**) for the electric (A) and gas (**B**) ranges. . . . . 92

## 1.0 Introduction

Nearly 3,700 deaths, about 19,000 injuries, and over \$4 billion in property damage were caused in 1995 in the United States by over 400,000 residential fires [1]. In recent analyses of data collected through the National Fire Incident Reporting System, **NFIRS**, the National Fire Protection Association has estimated that range/oven appliance fires, a majority of which involve food, average about 20% of all residential **fires** and are responsible for approximately 20% of the injuries, 5% of the deaths, and 5% of the property loss associated with residential fires [2]. Until recently, there was little research directed toward increasing understanding of the pre-ignition conditions of food fires that might be monitored to indicate an incipient **fire** or of the devices that might be used to detect and act upon such conditions. The objective of this project is to identify pre-ignition conditions and the methods and devices that can be used to detect such conditions and alert, or intervene, to reduce the risk of food fires associated with electric and gas ranges and **cooktops** and thereby reduce the number of cooking-related fires in homes. The ultimate goal of the overall study being conducted by the Consumer Product Safety Commission (CPSC) is to evaluate the overall feasibility, including cost and benefit, of incorporating such devices into ranges.

### 1.1 Review of Phase I

The objective was addressed through two major activities in Phase I. The details are provided in the Phase I report [3]. In order to identify the pre-ignition conditions, experiments were performed to monitor specific aspects of the environment and how they changed as ignition conditions were approached. Various foods were heated at high settings using electric and gas ranges with the range hood on for half of the tests. Temperatures of the surroundings close to the pan, plume velocity, and laser-attenuation measurements were recorded. A Fourier transform infrared, **FTIR**, spectrometer was used to determine if the production of any specific gas species was significant. Analysis of the experimental results determined that strong indicators of approaching ignition were high temperatures close to the pan, smoke particulate levels, and hydrocarbon gases. Monitoring one or more of these conditions was deemed promising for successful detection of approaching food ignition. **Additional** results of the Phase I work were that each of the particular electric and gas ranges tested produced similar ignition signatures for the same foods, but required different heating periods to achieve them, and that the particular range hood used did not have a significant effect on ignition conditions. The Phase I testing focused on three foods: soybean oil, bacon, and table sugar.

The second Phase I activity was the identification of methods, materials, and devices with potential for detecting and responding to pre-ignition conditions. This was accomplished with a literature and patent search which focused on sensing devices and technologies capable of detecting cooking-related conditions as well as control technologies capable of shutting off gas and electric ranges in the event of a detected threat. The bibliographical information on technologies related to these goals was provided with comments regarding their potential usefulness in a kitchen range pre-ignition detection system. The most promising technologies for monitoring the conditions of interest included tin-oxide sensors for hydrocarbon gases and carbon

monoxide, scattering- and attenuation-type photoelectric smoke detectors, and thermocouple **thermometry**. The search also revealed that logical processing of two or more detected signals has been used in other applications and could be utilized for food pre-ignition detection to limit false alarms. Finally, it was determined that control technologies exist that could be used upon the detection of pre-fire conditions for the shutdown and restart of gas and electric ranges.

## 1.2 Introduction to Phase II

Phase **I** demonstrated that common signatures of approaching ignition exist for the three foods cooked on electric and gas ranges. Phase II was designed to obtain additional data on cooking cases and practical sensors. The objective of Phase II was to determine whether there is potential for devices, alone or in conjunction with others, to detect approaching ignition and allow **alarm** or shutoff of the range for foods cooked on electric and gas ranges without generating undue false alarms during a variety of normal and usually safe cooking activities. The term “normal” will be used in this report to describe accepted, standard cooking procedures derived **from** recipes or range/oven operation manuals. “Normal” will also indicate that the procedure is attended or monitored. The **term** “false alarm” will generally be used to describe a situation in which a sensor output surpasses an established **alarm** threshold when normal cooking is **occurring** rather than unattended cooking, which is heating maintained at a high level beyond standard practice. Additional clarification of these terms will be used as specific situations are described.

The experiments were designed to (1) establish whether or not a set of normal cooking practices and a set of pre-ignition situations generate **sufficiently** different signatures to discriminate between these conditions, and (2) test a few readily available detection devices with the ability to respond to the signatures identified by (1). The experiments addressed a broad, yet **finite**, range of common cooking configurations to determine whether there is potential to detect impending food fires. The nature and extent of practical **difficulties** that might limit the application of certain devices were also assessed.

## 2.0 Experimental

### 2.1 General Design

The purpose of these tests was described in the Phase II introduction. In order to accomplish the purpose, a kitchen facility was necessary which included sources of electrical power and natural gas, ranges, range hood, and some means of air flow control. It was also **necessary** to develop a set of cooking cases and procedures that would reflect a broad range of environments for which the **performance** of the various sensors could be examined. This section addresses the design of these experimental elements.

#### 2.1.1 Facility Construction

A small, stand-alone laboratory was built for the Phase I testing and was used again for

Phase II. It was located in Building 205, the Large-Fire Facility, at the National Institute of Standards and Technology (NIST). The interior dimensions of the room were: 3.66 m (12 ft) width, 2.44 m (8 ft) depth, and 2.44 m (8 ft) height. Details of the room's construction including a drawing are contained in the Phase I report [3]. The same cabinets were retained to reproduce a kitchen environment. Additional access holes were made in the room walls for external supplies of electrical power and natural gas as well as a large amount of sensor wiring. A range hood (described in Section 2.1.2) was installed above the range. The same range-hood ductwork and room exhaust hood and ductwork were used as described for Phase I [3].

Electrical power and natural gas were provided in a similar manner as before [3]. The same 220 V house circuit, boosted to 240 V, was used. Additional 120 V electrical cords were added to accommodate the several power supplies needed for sensors, detectors, and heating tapes. A higher capacity rotameter was used on two tests due to a much higher natural-gas demand. The flow was monitored either with the 4.7 L/min (10 SCFH) rotameter used for Phase I or the higher capacity 23.6 L/min (50 SCFH) rotameter. The gas delivery pressure was maintained at 1.7 kPa (7.0 in of water).

### 2.1.2 Kitchen Ranges and Range Hood

Four different ranges were used in these tests: A - electric with open-coil sheathed heating elements; B - **high-output**, sealed-burner gas; C - electric smoothtop; and D - down-draft electric slide-in with a grilling attachment. The majority (34) of the tests were conducted on range A, four tests utilized range B, and two tests each were performed on ranges C and D. Each range was 76 cm (30 in) wide. The electric range with open-coil elements had two 15 cm (6 in) and two 20 cm (8 in) burners. The 15 cm and 20 cm burner elements were rated at 1.33 kW and 2.35 kW, respectively, for 240 V electricity. The front set of burners on each range was used for the pan of focus as in Phase I in order to allow comparison with the previous measurements. The larger, **higher-output** burner was always used for the pan of focus to maximize the food heating rate and minimize the time to ignition. The gas range had two 2.6 kW (9000 BTU/h) burners and two 3.5 kW (12000 BTU/h) burners. The gas range's large burner was on the left in contrast to the right for the electric range. The smoothtop electric range, including the oven and burners, was rated for 11.4 kW at 120/240 V. It was used only for the oven's self-cleaning capability. The **down-draft** range was used for its grilling and down-draft features, and it was rated for 14.1 kW at 120/240 with a fan capacity of 236 L/s (500 cfm). The grilling attachment was located on the right side of the range.

The range hood was a 76 cm (30 in) wide model made of stainless steel, and it had a 170 L/s (360 cfm) flow capacity. This unit's cost and flow capacity were above average for the range hoods on the market, yet such models were generally available. The hood opening extended 45 cm (18 in) out from the wall and tapered from about 75 cm (29.5 in) wide at the wall to 63 cm (25 in) at the front over the **frontmost** 24 cm (9 in). It was not in use for most experiments, but was engaged at maximum flow for several experiments in order to determine its effect on the results.

### 2.1.3 Test Case Cooking Procedures and Parameters

The purpose of this set of experiments was to characterize the environment **preceding** ignition during simulated unattended cooking and the potential for false-alarm generation during periods of normal cooking. In order to maximize the data available from each test, some tests combined an initial period of normal cooking followed by a period of simulated unattended cooking on high heat. Some normal cooking tests which were not extended to unattended situations were chosen because they ordinarily utilize high heat and/or produce visible and sometimes accumulating smoke. Other tests were similar to the Phase I tests in that they simulated the unattended, high-heating situation from the beginning.

Three parameters were varied in order to establish their effects on the pre-ignition and normal cooking signatures: (1) food type, (2) range type, and (3) hood operation. A wider variety of foods was tested than in Phase I. Industry input was sought to develop a representative set of cooking cases. Although there are nearly an infinite number of cooking situations, sixteen different cases were studied to encompass a **sufficiently** broad range of cooking activities to ensure that any evidence for a detection window between normal and dangerous conditions was broadly applicable. Gas and electric ranges were of interest because of potential differences in thermal and chemical environments due to the ranges themselves, regardless of the food being cooked, as well as the different temperature-time histories for the same cooking operation. The range-hood status was of interest primarily because a forced air flow has the potential to either enhance the signals generated during normal cooking or weaken those generated during approaching ignition. Any detection system must not be confused by the use or non-use of a range hood. A range hood with 70% greater flow capacity than that used in Phase I was installed in order to answer questions about the effect of a hood having a flow capacity closer to the maximum generally available on the market.

Table 1 describes the sixteen cooking cases tested in Phase II. All single-pan cases used a large, front burner. For all multi-pan cases, the combustible-food pan was located on the large, front burner. This baseline set of tests used the A-type electric range (except for cases 6 and 15 as is explained later). The range hood was inactive to allow for worst-case build-up of cooking products. Cases 1 and 3 are unattended and were selected to establish pre-ignition conditions using the Phase II instrumentation set for the same **cases** tested in Phase I. Cases 4, 5, 7-9, 11, and 13 were selected to represent normal cooking activities. Cases **7-9**, 11 and 13 involve unattended cooking following a period of normal cooking procedures. These cases are designated **"normal→unattended"** and were designed to provide both normal and pre-ignition data. Cases 1-3, 10, 12, and 14 simulate unattended cooking for the entire duration of the tests. All unattended cases, whether following normal cooking or not, utilize the highest burner setting even if the normal procedure does not prescribe heating on high. This was done to achieve the fastest ignition possible which was deemed the most dangerous situation. Case **6** employs the C-type smoothtop range with the self-cleaning oven feature. Two additional normal cooking cases, 15 and 16, were added based on suggestions from the range industry. Case 15 uses the D-type down-draft grilling range, and case 16 uses the A-type electric range. Cases 1 and 2 were designed to assess effects of differences in cookware material. The number of tests designed to examine cooking behaviors using electric ranges with the range hood off **totalled** 32 (16 cases,

Table 1. Case description and procedure list.

Cooking Cases	Descriptions	General Procedures
1. Soybean oil (A) (unattended)	500 mL oil in a 26 cm (10 in) diameter stainless-steel (aluminum bottom) frying pan.	Heat on high until ignition.
2. Soybean oil (B) (unattended)	500 mL oil in a 26 cm (10 in) diameter heavy gauge aluminum frying pan.	Heat on high until ignition.
3. Bacon (unattended)	227 g (8 oz) bacon in a 26 cm (10 in) diameter stainless-steel (aluminum bottom) frying pan.	Thaw bacon. Heat on high until ignition.
4. Water - multiple pans (normal)	4 pans: 2.5 L water in 3.8 L (4 qt) stainless-steel (aluminum bottom) sauce pans.	Heat 1 pan of water on high with pan covered, but allowing for pressure release. After water is rapidly boiling, remove cover from pan. Heat the remaining 3 pans and remove the covers one at a time every 20 min after they have reached boiling. Then maintain the boiling another 20 min after all of the covers are removed.
5. Broiled steak (normal)	454 g (1 lb) T-bone steak and 15 mL (1 tbsp) soybean oil in broiling pan.	Thaw meat, preheat broiler for 4 min. Slash meat every 5 cm (2 in). Place broiler such that meat is approximately 8 cm (3.1 in) from the heating element. Broil for 10 min with the door closed. Turn meat and broil for 10 min more with the door partly open.
6. Self-cleaning oven operation with debris (normal)	227 g (8 oz) of raw beef suet.	Divide suet in many (approx. 25) small pieces and distribute evenly in broiler pan. Activate the self-cleaning oven cycle.



Cooking Cases	Descriptions	General Procedures
7. French-fried potatoes in soybean oil (normal→unattended)	227 g (8 oz) frozen french-fried potatoes and 500 mL oil in a 26 cm (10 in) diameter stainless-steel (aluminum bottom) frying pan.	Heat oil to 190 °C (374 °F) on high. Introduce frozen fries to oil. Reduce heat to medium-high and turn fries until done. Increase heat to high until ignition.
8. Macaroni and cheese (normal→unattended)	206 g (7.25 oz) macaroni in 1.42 L (6 cps) water in 2.8 L (3 qt) medium gauge aluminum sauce pan. Additions: 59 mL (4 tbsp) margarine, 59 mL (0.25 cp) skim milk, cheese sauce packet.	Boil water rapidly on high heat. Add macaroni and stir. Boil 9 min. Drain and mix in margarine, milk, and cheese. Place back on burner on high heat.
9. Soybean oil and water (normal→unattended)	1 pan: 500 mL oil in a 26 cm (10 in) diameter stainless-steel (aluminum bottom) frying pan. 3 pans: 2.5 L water in a 3.8 L (4 qt) stainless-steel (aluminum bottom) sauce pot.	Heat oven to 204 °C (400 °F), and heat water on high on three burners. After 9 min, heat oil on high on one burner for 5 min. Decrease heat under oil to medium-low. After 18 min, increase heat under oil to high until ignition.
10. Soybean oil - multiple pans (normal→unattended)	4 pans: 500 mL oil in a 26 cm (10 in) diameter stainless-steel (aluminum bottom) frying pan.	Heat oven to 204 °C (400 °F), and heat oil on high on all burners for 5 min. Decrease heat on all four burners to medium-low. After 15 min, change one burner's heat setting to high until ignition.

Cooking Cases	Descriptions	General Procedures
11. Chicken in soybean oil (normal→unattended)	Approximately 750 g (1.65 lb) of chicken (3 whole legs) in 500 mL soybean oil in a 26 cm (10 in) diameter stainless-steel (aluminum bottom) frying pan.	Heat oil to 190 °C (374 °F) on high. Introduce chicken to oil. Reduce heat to medium and turn chicken every 4 min for 20 min. Increase heat to high until ignition.
12. Chicken in soybean oil (unattended)	Approximately 750 g (1.65 lb) of chicken (3 whole legs) in 500 mL soybean oil in a 26 cm (10 in) diameter stainless-steel (aluminum bottom) frying pan.	Heat oil to 190 °C (374 °F) on high. Introduce chicken to oil. Maintain high heat until ignition.
13. Stir-fry vegetables in soybean oil (normal→unattended)	283 g (10 oz) stir-fry vegetable mix and 50 mL (3.4 tbsp) soybean oil in a 36 cm (14 in) diameter stainless-steel wok with burner ring.	Heat oil to 280 °C (536 °F) on high. Introduce vegetables. Stir vegetables constantly at medium-high heat for 5 min. Increase heat to high until ignition.
14. Stir-fry vegetables in soybean oil (unattended)	283 g (10 oz) stir-fry vegetable mix and 50 mL (3.4 tbsp) soybean oil in a 36 cm (14 in) diameter stainless-steel wok with burner ring.	Heat oil to 280 °C (536 °F) on high. Introduce vegetables. Stir vegetables for 15 s to coat with oil. Maintain heat on high until ignition.
15. Grilled steak (normal)	Grill 454 g (1 lb) T-bone steak on grilling attachment of down-draft range.	Thaw meat, and preheat grill for 5 min. Slash meat every two inches. Place meat on grill. Grill for 5 min, turn meat and grill for 5 min. Repeat.

Cooking Cases	Descriptions	General Procedures
16. Blackened catfish (normal)	Approximately 227 g (8 oz) catfish fillet and 50 mL (3.4 tbsp) melted butter in a 26 cm (10 in) diameter stainless-steel (aluminum bottom) . frying pan.	Heat butter to 100 °C (212 °F). Pre-heat pan on high for 3 min. Put melted butter in pan. Place fillet in pan. Sprinkle blackening seasonings on the exposed side. Heat for 2 min, turn and season, heat for 2 min, and remove from heat.

2 tests/case). The initial tests and their repeats were randomized within each range type to minimize systematic errors. Table 2 lists the tests in the order they were conducted. The times listed in Table 2 are discussed in Section 4.1.

Cases 5, 9, and 11 were repeated (an additional two tests each) with the range hood on to evaluate the effects of the range hood's air flow on the measurements. The high-flow-capacity range hood was used with its highest setting for each of these tests. Air flow velocities in the hood were measured with a bidirectional probe [4,5]. Phase I test results were insensitive to the flow induced by a moderate-flow-capacity range hood [3]. Cases 9 and 11 were repeated (an additional two tests each) on the B-type gas range with the range hood inactive to characterize the effects of range type on the measurements. The additional tests to examine these variables **totalled** 10 (5 cases and 2 tests/case). Figure 1 shows the categories of tests that were conducted.

One additional test was not fully instrumented and therefore is not included in the case list. It characterized the residual heating effect of a deenergized electric burner. A **stainless-steel/aluminum-bottom** frying pan, like those used for the cooking tests with 500 mL of soybean oil, was placed on the large **burner** on range A with thermocouples monitoring burner, pan, and food temperatures. At 30 s to 60 s before previously experienced ignition times, the burner was deenergized, and data were obtained regarding thermal inertia and time to temperature decrease. This information about time to temperature decrease was used to ascertain the minimum period preceding ignition required to shut down the range in order to prevent reaching ignition conditions. In other words, this established the latest shutdown time for this test after which ignition would not occur. Only one test was conducted so the results only provide a rough estimate of this time. Additional testing by the CPSC was planned to provide more data on this issue.

## 2.2 Instrumentation

A variety of instruments was used to characterize the pre-ignition cooking environment. Measurements focused on those aspects showing the most potential from Phase I. Table 3 describes the instrumentation used in the discrimination test series.

### 2.2.1 Gas Analyzers

A gas-sampling probe was located 23 cm (9 in) above the center of the large burner surface in order to monitor the gases evolved from the cooking process. The probe consisted of a 2.4 m (8 ft) length of 6.4 mm (0.25 in) OD copper tubing. The probe is portrayed in Figure 2. A pump was used to draw gases through the probe to a rack of analyzers. A portion of the unaltered sample passed through a total-hydrocarbon (**HC**) analyzer. The remainder of the flow passed through a dry-ice trap, a paper filter, and a tube of desiccant, and then into a combination carbon dioxide (**CO<sub>2</sub>**) and carbon monoxide (**CO**) analyzer. Heating tape was wrapped around the probe from approximately 7 cm (2.5 in) above the probe tip to the sample inlet for the hydrocarbon analyzer. The heating tape was maintained at approximately 50 °C (122 °F) by three variable current supplies in order to limit condensation. The hydrocarbon analyzer was a

Table 2. Experimental test matrix.

Test No.	Range , Type	Hood Status	Case No.	Case Description	Normal/ Unattended	$t_{\text{ignition}}$ 's	$t_{\text{normal}}$ 's
1	Electric (A)	Off	1	Oil (stainless steel)	U	608	
2	Electric (A)	Off	3	Bacon	U	605	
3	Electric (A)	<b>Off</b>	12	Chicken (unattended)	U	1849	
4	Electric (A)	Off	5	Broiled steak	N		1528
5	Electric (A)	Off	4	Water	N		4139
6	Electric (A)	<b>Off</b>	7	Fries	Nu	1236	735
7	Electric (A)	On	9	Water, oil	<b>NU</b>	2359	1980
8	Electric (A)	<b>Off</b>	11	Chicken (normal)	<b>NU</b>	2668	1520
9	Electric (A)	On	5	Broiled steak	N		1518
10	Electric (A)	Off	13	Stir-fry (normal)	<b>NU</b>		620
11	Electric (A)	<b>Off</b>	16	Catfish	N		480
12	Electric (A)	Off	9	Water, oil	<b>NU</b>	2358	1980
13	Electric (A)	Off	10	Oil (4 pans)	<b>NU</b>	1632	1260
14	Electric (A)	Off	<b>14</b>	Stir-fry (unattended)	U		
15	Electric (A)	On	11	Chicken (normal)	Nu	2699	1530
16	Electric (A)	Off	5	Broiled steak	N		1500
17	Electric (A)	Off	3	Bacon	U	561	
18	Electric (A)	<b>Off</b>	2	Oil (aluminum)	U	594	
19	Electric (A)	<b>Off</b>	4	Water	N		<b>4440</b>
20	Electric (A)	<b>Off</b>	8	Macaroni & cheese	Nu	3197	945
21	Electric (A)	<b>Off</b>	16	Catfish	N	510	489
22	Electric (A)	<b>Off</b>	7	Fries	<b>NU</b>	1214	705
23	Electric (A)	Off	13	Stir fry (normal)	Nu	1157	610
24	Electric (A)	<b>Off</b>	<b>1</b>	Oil (stainless steel)	U	637	
25	Electric (A)	<b>Off</b>	11	Chicken (normal)	<b>NU</b>	2721	1520
26	Electric (A)	<b>Off</b>	14	<b>Stir-fry</b> (unattended)	U	1005	
27	Electric (A)	<b>Off</b>	2	Oil (aluminum)	U	616	
28	Electric (A)	On	9	Water, oil	<b>NU</b>	2409	1980
29	Electric (A)	On	5	Broiled steak	N		1500
30	Electric (A)	<b>Off</b>	10	Oil (4 pans)	<b>NU</b>	1688	1260
31	Electric (A)	Off	12	Chicken (unattended)	U	1858	

Test No.	Range Type	Hood Status	Case No.	Case Description	Normal / Unattended	t <sub>ignition</sub> ' s	t <sub>normal</sub> ' s
32	Electric (A)	Off	9	Water, oil	NU	2379	1980
33	Electric (A)	Off	8	Macaroni & cheese	NU		1016
34	Electric (A)	On	11	Chicken (normal)	NU	2767	1535
35	<b>Gas (B)</b>	<b>Off</b>	9	Water, oil	NU		1980
36	<b>Gas (B)</b>	<b>Off</b>	11	Chicken (normal)	Nu	4387	1560
37	<b>Gas (B)</b>	<b>Off</b>	9	Water, oil	NU		1980
38	<b>Gas (B)</b>	<b>Off</b>	11	Chicken ( <b>normal</b> )	Nu	4170	1580
39	Electric (C)	<b>Off</b>	6	Se&cleaning	N		
40	Electric (C)	Off	6	<b>Self-cleaning</b>	N		
41	Electric ( <b>D</b> )	On to off	15	Grilled steak	N		1609
42	Electric ( <b>D</b> )	On to off	15	Grilled steak	N		1618

**Pre-Fire/Normal Cooking  
Discrimination Tests  
(Electric Range, Hood Off)**

**Hood Effect Tests  
(Electric Range,  
Hood On)**

**Range Effect Tests  
(Gas Range, Hood Off)**

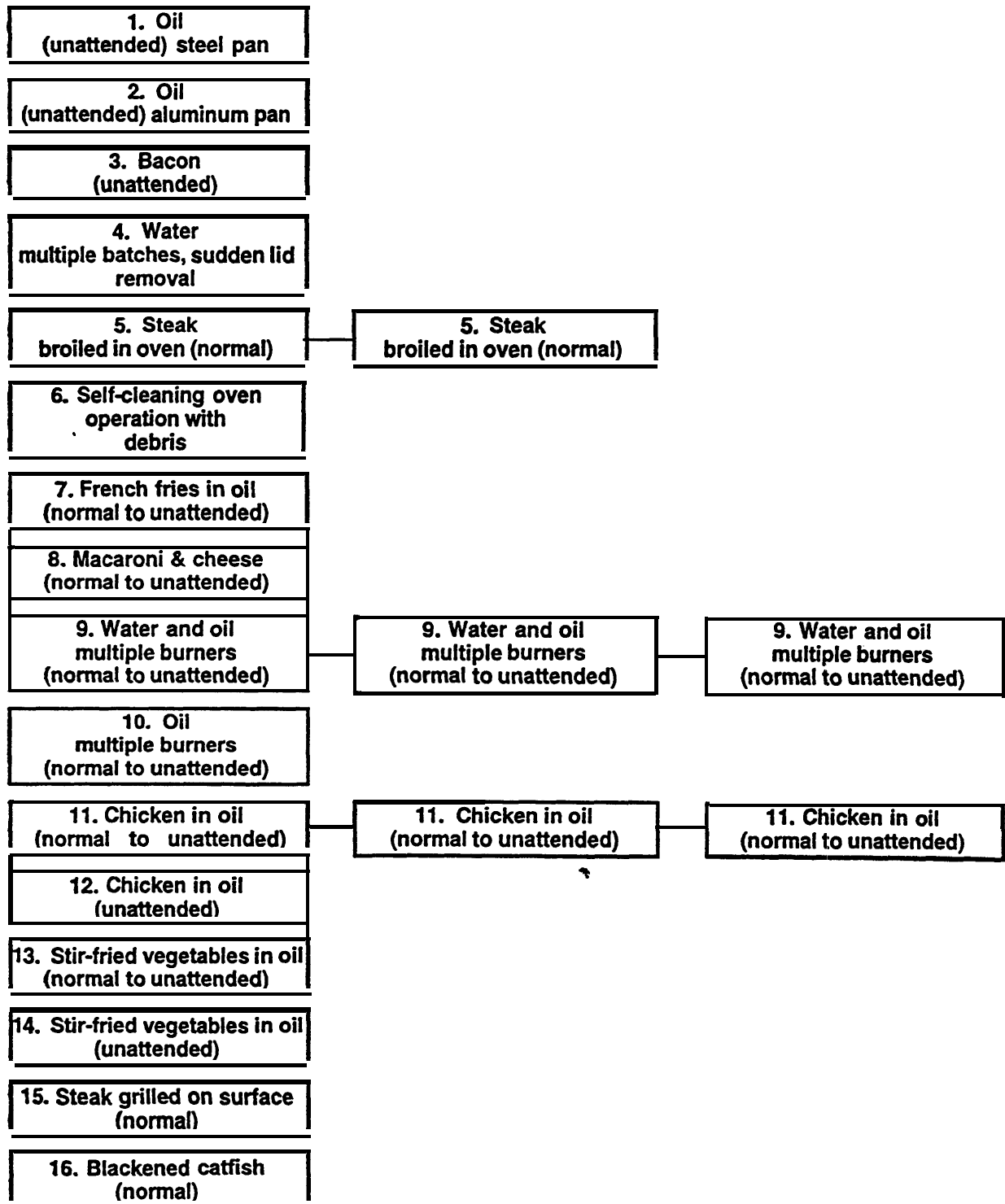
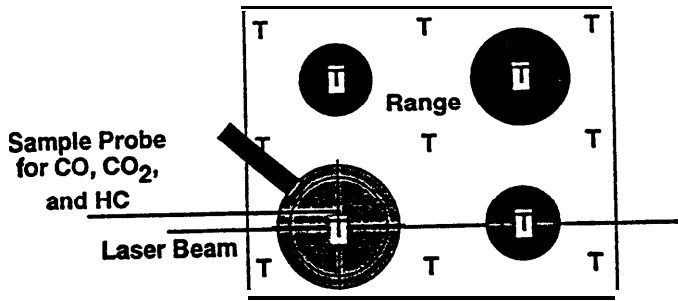
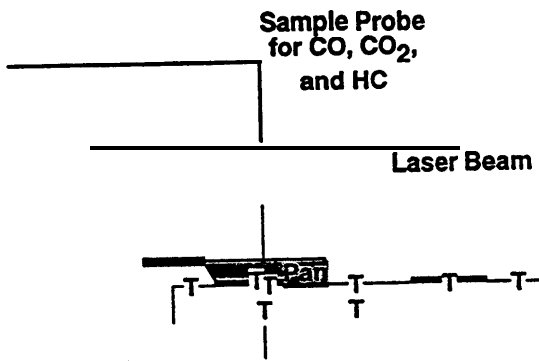

Figure 1. Categories of tests.



Range - Top View



Range - Front View

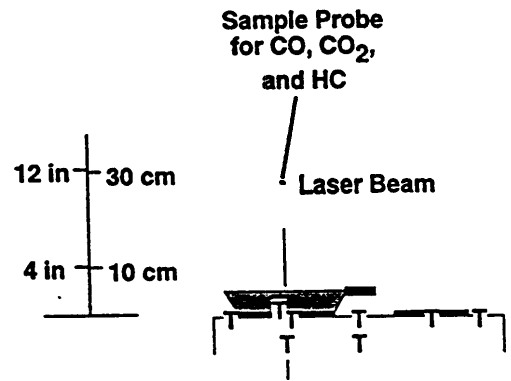

Range - Side View

Under-surface thermocouple applied for electric range A only

**Key**

T Thermocouple Location

Figure 2. Locations of near-range probes and thermocouples.



Table 3. Instrumentation list.

Instrument	Measurement	Location
Laser ( <b>HeNe</b> ) and photodiodes	Laser attenuation and scattering by smoke related to relative aerosol mass concentration above cooking area	<b>23</b> cm (9 in) above burner surface. See Figure 3
Thermocouples	Temperatures	See Figures 2, 3, 4
Total-hydrocarbon <b>analyzer</b>	Hydrocarbon gas volumetric concentration as methane equivalent (only those not condensable < 50°C)	Above hydrocarbon food, see Figure 2
Carbon dioxide <b>analyzer</b>	Carbon dioxide volumetric concentration (dry basis)	Above hydrocarbon food, see Figure 2
Carbon monoxide <b>analyzer</b>	Carbon monoxide volumetric <b>concentration</b> (dry basis)	Above hydrocarbon food, see Figure 2
Bidirectional <b>probe [4,5]</b>	Range-hood duct flow velocity	30 cm ( <b>12</b> in) before last vertical section of duct
Video camera	Visual record of cooking area phenomena	Outside room, focused on cooking region
Data acquisition system	Data collection	Outside room

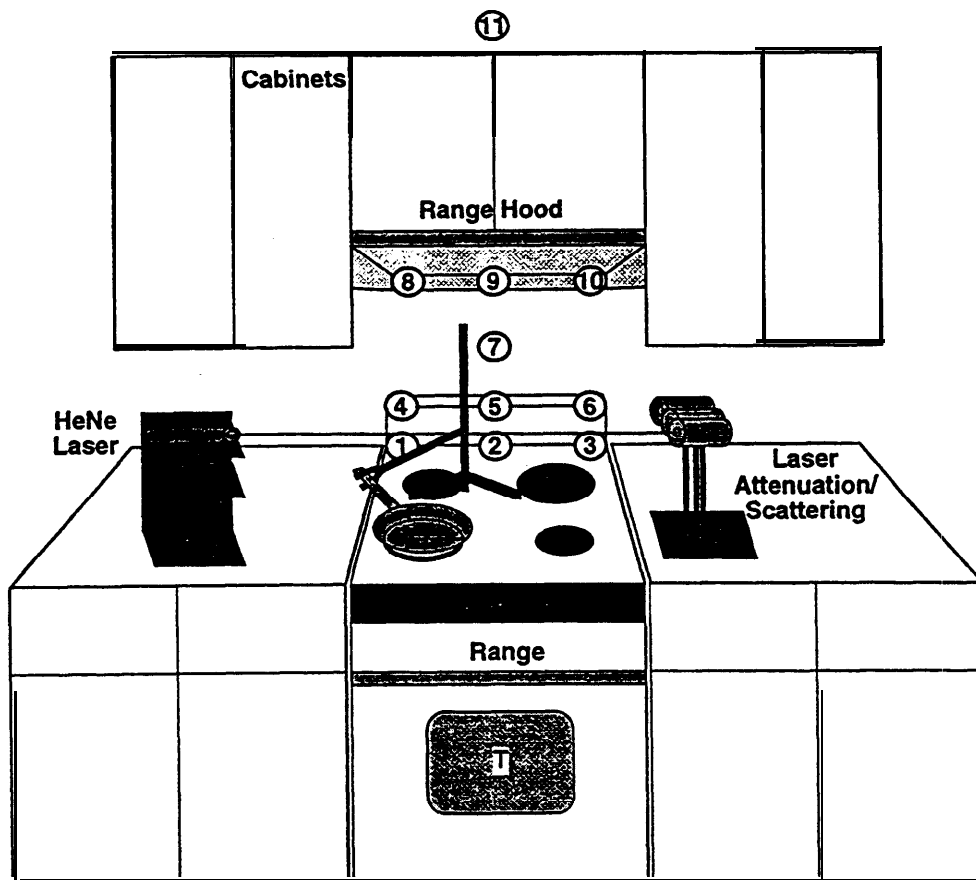

Overall View

Key

- ⑪ Sensor Housing Location
- T Thermocouple Location

Figure 3. Schematic of near-range configuration, instruments, sensors, and thermocouples.

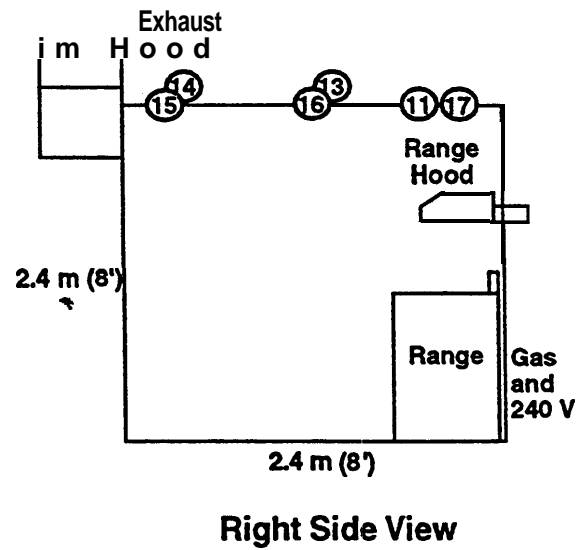
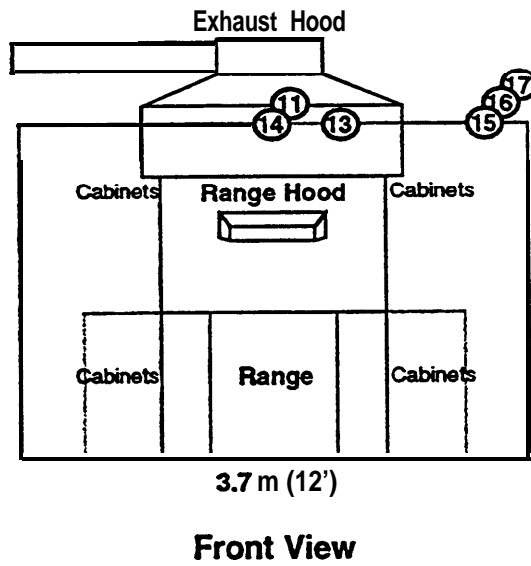
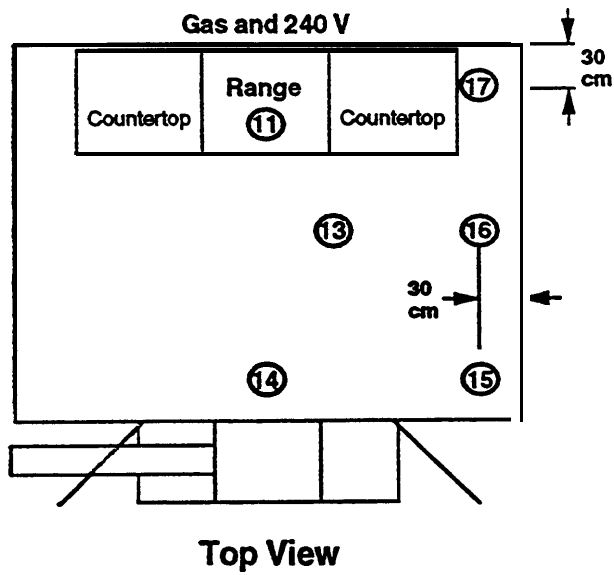

**Key**

⑪ **Sensor Housing Location**

Figure 4. Locations of sensors and thermocouples away from the range.

Rosemount Model **400A\***. The hydrocarbon measurement was calibrated in terms of the equivalent concentration of methane. The combination **CO<sub>2</sub>** and CO analyzer was an Infrared Industries Dual Gas Analyzer and used non-dispersive infrared technology. Both **CO<sub>2</sub>** and CO concentrations were measured from dry gas samples.

### 2.2.2 Thermocouples

Thermocouples were used to measure temperatures in three general areas: near the food, around the range, and above the range. For the area near the food, thermocouples were placed at the center of each burner and contacted to the pan bottom if a pan was present. The contact was not through permanent fastening, but was ensured by spring loading the thermocouple. For electric range A, the thermocouple was located inside the center coil of the burner element and did not contact the element itself. For the gas range, the thermocouples were also bent in order to contact the pan bottom, and for protection, ceramic tubes were placed around the thermocouples in the vicinity where they passed through the flame. One thermocouple was placed in the food near the center of the pan. The pan and food thermocouples were all Omega model number KMQSS-020(G)-12 [stainless-steel sheathed, 0.51 mm (0.020 in) sheath diameter, K-type (Chromel-Alumel), grounded, 30 cm (12 in) long]. For range A, additional thermocouples were located on the drip pan centered below the burner and on the surface beneath the drip pan centered below the burner.

For the area around the range, thermocouples were placed on the top surface at **left**, center, and right positions along the front and midway back from the front of the burner area of the range. For range A, a thermocouple was also placed beneath the top surface of the range at the center left to right and front to rear of the burner area. These locations are depicted in Figure 2. A thermocouple was placed on the upper **surface** inside the oven 5.5 cm (2.2 in) behind the door opening and centered across the oven.

For the area above the range, one thermocouple was placed above the food in the buoyant plume approximately 3 mm (0.1 in) below the end of the sample probe. Thermocouples accompanied each of the sensor-group sites located on or near the range hood as well as those located on the ceiling. These are shown in Figures 3 and 4. A pair of thermocouples were placed on the inside surface of the front edge of the **range** hood. These thermocouples were Omega model no. **SA1-K [30** gauge, 0.25 mm (0.010 in) diameter, K-type (Chromel-Alumel), 91 cm (36 in) long, Teflon insulated, self-adhesive backing]. A thermocouple was also located under each of the **left** and right filter elements of the hood. These thermocouples and those used at each sensor site and on the range surface were Omega model no. **5TC-GG-(K)-30-(72) [30** gauge, 0.25 mm (0.010 in) diameter, K-type (Chromel-Alumel), 183 cm (72 in) long, glass braid

---

\*Certain commercial equipment, instruments, or materials are identified in this report to specify adequately the experimental procedure which allows its duplication. Such identification does not imply recommendation, endorsement, or disapproval by the National Institute of Standards and Technology, nor does it imply that the materials or equipment identified are necessarily the best available for the purpose. Some of the materials or equipment were used in a manner or conditions for which they were not designed.

insulation]. The assortment of thermocouples used for the experiments cost approximately \$10 to \$30 each.

### 2.2.3 Laser-Attenuation and Scattering Apparatus

Laser attenuation and scattering measurements were performed in order to monitor the quantity and characteristics of the smoke produced during each test. Laser attenuation is due to light reflection and absorption and is the fraction of initial laser intensity that does not **transmit** through a cloud of particulates. A laser-attenuation system consists of a laser and a light detector, such as a photodiode, aligned optically so the laser light passes through the medium to be measured and into the photodetector. In Phase I, two laser-attenuation systems were used at two different heights above the burner of interest, 18 cm (7 in) and 28 cm (11 in) [3]. For Phase II, only one laser-attenuation system was used at a height of 23 cm (9 in), but in addition to an attenuation measurement, attempts were made to gather light-scattering data at two angles. The He-Ne laser-attenuation and scattering system was arranged such that the beam passed through the axis of symmetry of the pan of focus. The optics were open and accessible rather than **self**-contained such as in photoelectric smoke detectors. The He-Ne laser was a Melles Griot model number **05-LLR-811** and generated a 1 **mW** beam. It was mounted on a **vertical-translation** stand to enable alignment. The laser and photodiode detector are depicted in Figure 3.

Laser-light scattering is the fraction of initial laser intensity that is reflected by a cloud of particulates. Relative scattered-light intensities were measured by two additional photodiodes which were mounted on optical rods and connected to power sources and signal amplifiers. The scattering was measured at 5° and 10° from the **forward** direction. The photodiodes (**Hamamatsu S1337-1010BQ**, 100 **mm<sup>2</sup>** active surface area), operational amplifier circuits, power source box, and mountings with connections for power input and signal output were the same as those used by Pitts et al [4] and for Phase I [3]. An iris was also placed in front of each photodiode and opened to approximately 4 mm (0.16 in) to reduce the amount of stray light that could reach the photodiodes. For the scattering photodiode detectors, narrow band-pass filters (Melles Griot **03FIL006**, 632.8 nm) were installed to only allow light of the laser's wavelength to pass through. The pre-test output of the attenuation photodiode amplifier with unobstructed laser light was 7 V - 9 V.

### 2.2.4 Video and Photographic Equipment

As in Phase I, a VHS video camera was centered outside of the doorway of the laboratory and focused to capture a view of the cooking scene. Close views were recorded at early stages of heating and wider views were recorded when smoke generation began. A zoom-lens camera was used to take still 35 mm slide photographs of the test area and cooking process.

## 2.3 Sensors and Detectors

This section describes the readily available gas sensors and smoke detectors which were installed to determine their capability to differentiate between normal and pre-ignition conditions.

### 2.3.1 Gas Sensors

Criteria were developed for the sensors to be used in the study as part of the Phase I NIST effort. The following list highlights the key sensor selection considerations. These criteria were for test purposes only and are not universal guidelines for sensor selection.

1. Available as a functioning model, even if a prototype.
2. Cost less than \$250 for one or \$500 for multiple samples.
3. Reusable - not ruined, destroyed, or altered by detection of the pre-ignition signature or by a power **off/on** cycle.
4. Unobtrusive, with potential for additional miniaturization or installation within/on the range without obstruction of cooking activities, counter space, or hood flows.
5. Include instructions or ready access to consultation with the manufacturer.
6. Have a means of perceiving the pre-ignition signature from a range-mounted location, or if non-range-mounted, require little modification or installation effort.
7. Capable of continuous analog output or an analog alarm signal output.
8. Not susceptible to contaminant accumulation.

Tin-oxide gas sensors were selected from two manufacturers based on these criteria and applied to this investigation. The first, Figaro, markets several Taguchi-type thin-film sensors with sensitivities geared towards specific groups of gases. The sensors used were those marketed as sensitive to general hydrocarbons (**TGS813**), general alcohols and volatile organic compounds (**TGS822**), general cooking gases (**TGS880**), cooking alcohols (**TGS882**), and water vapor (**TGS883**). Except for the water-vapor sensor, each of these sensors responded to several gases including methane, carbon monoxide, ethanol, propane, isobutane, and hydrogen, but with different combinations of sensitivities. The gas sensor sensitivities were affected by both temperature and humidity so sensor outputs resulted from combined reaction to levels of the hydrocarbon gas mixture, water vapor, and temperature. The effects of the three variables on sensor output were in the same direction, i.e., increased levels of each variable increased sensor output. Costs for the gas sensors ranged from \$10 to \$25 each.

The sensors were connected to output circuits and 15 V dc power supplies. The sensors' internal heating elements were supplied with a 5 V heating voltage. Three to six sensors were powered by each power supply. Sensors were placed **individually** or with one or two others in a sensor housing. The housings consisted of 4.4 cm (1.75 in) long pieces of 7.0 cm (2.75 in) OD bakelite tubing with 0.3 cm (0.12 in) wall thickness attached to a 0.5 cm (0.19 in) thick disk of bakelite at one end with mounting holes for the sensors.

Carbon monoxide sensors were purchased from Capteur Sensors and **Analysers**, Ltd. These were thick-film tin-oxide sensors (part no. **1C-G-S-0-05-CM-E-07**) and came with a filter to eliminate hydrocarbons. Their cost was approximately \$70 each. Each CO **sensor** used a 5 V dc power supply and had its own printed circuit board to regulate the heating **element** to maintain a constant temperature between 400 °C (750 °F) and 500 °C (930 °F). The sensor's resistance varied depending on the gas concentration, and a simple voltage-divider circuit was constructed to provide an output signal.

The approximate sensor locations are shown in Figures 3 and 4. Table 4 summarizes the sensors used in the discrimination test series. Table 5 is the key for all of the individual sensors

Table 4. List of sensors.

<b>Sensor</b>	<b>Measurement</b>	<b>Location</b>
Thermocouples	Temperatures	See Figures 2, 3, 4
Smoke-particulate sensors (4 ionization and 8 photoelectric)	Voltage representing detector response and transition to alarm state	Several locations. See Figures 3, 4
Gas sensors (tin-oxide type): carbon monoxide, hydrocarbons, volatile <b>organics</b> , cooking gases, cooking alcohols, water vapor	Voltage representing response to contacting gases	Several locations. See Figures 3, 4

Table 5. Identification key for sensors and detectors.

Sensor Group or Designation	Associated Sensors, Detectors
A	General-hydrocarbon sensor General-alcohols ( <b>VOCs</b> ) sensor
Ah	Same as A with heat resistant cases
B	Total-cooking-gases sensor Cooking-alcohols sensor Water-vapor sensor
C	Total-cooking-gases sensor
D	Carbon monoxide sensor
X	Photoelectric smoke detector
Z	Ionization smoke detector
T	Thermocouple temperature sensor



and sensor groups and types employed in the following tables and figures. The locations of the sensors and sensor groups are depicted in Figures 2-4. Table 6 lists the sensors groups and their relative orientations. Twenty-five sensors were mounted in 16 housings in 11 locations near the range. A site for various sensors was not a single point, but an area where: some combination of sensors was clustered. Two of the general sensors were ordered with special heat-resistant housings, and these were placed at site 9 near the majority of food ignitions. The heat-resistant versions cost about \$25 each which was about twice as much as the regular models.

### 2.3.2 Smoke Detectors

The photoelectric-type smoke-detector models used were a type available for household or commercial use. They consisted of a detector module, mounting base, and test cable. The model numbers were Detection Systems DS-250, **MB4W**, and **TC2000**, respectively. The base diameter was 16 cm (6.3 in). The plug-in test cable produced an analog voltage signal. The eight detectors were all powered by a single 12 V dc power supply. Alarm signals were also recorded from the photoelectric detectors. These detectors cost about \$45 each.

The ionization-type smoke detectors were an inexpensive model (\$10-\$15 each) designated for home use. The manufacturer donated three of the four units used and provided modification instructions that enabled retrieval of analog responses and alarm voltages without affecting product performance. The ionization-detector diameter was 14.2 cm (5.6 in). The four detectors were each powered by individual 9 V batteries.

Both types of smoke detectors were only used for providing an alarm signal and not for quantitative smoke-obscuration measurements. The detectors were all listed and labeled by Underwriters Laboratories (**UL**). The detector locations are shown in Figures 3 and 4 and described in Table 6 using Table 5 as the key.

## 2.4 General Procedure

Each experiment began with no heat applied to the food and ended soon after ignition of the food or upon completion of the cooking procedure. The general steps involved in these experiments are provided in Appendix A. Usually **two** or three personnel would conduct each test. Because of the frequency with which fires occurred, additional help was often notified when the food was about to ignite. A test log sheet was used to make notes of the times and nature of phenomena and observations. A sample blank sheet is included as Appendix B.

## 2.5 Data Acquisition, Reduction, and Plotting

Data acquisition, reduction, and plotting were accomplished using the same equipment and software as in Phase I. A more complete description of these processes is included in the Phase I report [3]. A computer, scanner box, and digital voltmeter constituted the data acquisition system. The data system had a capacity of 60 instrument channels and 160 thermocouple channels, but 56 and 42, respectively, were actually used. The data system was capable of scanning the 98 channels at 8 s intervals, which was the setting for most tests, but a few of the

Table 6. Sensor and detector location descriptions.

Site No.	General Location	Sensor Groups	Specific Sensor-Housing Orientation
1	Base of splash panel at left edge of range	C	Centered at nominal site location
2	Base of splash panel at center of range	C	Centered at nominal site location
3	Base of splash panel at right edge of range	C	Centered at nominal site location
4	Top of splash panel at center of range	C	Centered at nominal site location
5	Top of splash panel at center of range	C	Centered at nominal site location
		X	Centered 1.3 cm (0.5 in ) above C housing, contacting both 7A and 7B
6	Top of splash panel at right edge of range	C	Centered at nominal site location
7	On rear wall just below range hood at center of range	A	Contacting bottom of range hood with left edge of housing against the plane of range symmetry
		B	Contacting bottom of range hood with right edge of housing against the plane of range symmetry
8	Front of range hood at left edge of range	C	Centered at nominal site location
9	Front of range hood at center of range	Ah	Contacting front edge of range hood with left edge of housing against the 9D housing
		B	Contacting front edge of range hood with right edge of housing against the 9D housing
		D	Contacting front edge of range hood centered on hood
		X	Oriented vertically with base plane along plane of hood front edge and bottom centered over and contacting 9D housing.
10	Front of range hood at right edge of range	C	Centered at nominal site location

Site No.	General Location	Sensor Groups	Specific Sensor-Housing Orientation
11	On the ceiling over front, center of range hood, i.e., above site 9, 46 cm (18 in) from rear wall	A	Contacting the front of 11X with left edge of housing against the plane of range symmetry
		B	Contacting the front of 11X with right edge of housing against the plane of range symmetry
		D	Contacting both 11A and 11B to the front, centered on plane of range symmetry
		X	Centered at nominal site location
13	On the ceiling, centered front to back, 106 cm (42 in) from right wall	X	Centered at nominal site location
14	On the ceiling, centered left to right, 15 cm from front wall	X	Centered at nominal site location
		Z	Contacting 14X to the right, 15 cm (6 in) from front wall
15	On the ceiling, 30 cm (12 in) from right wall and front wall (square)	X	Centered at nominal site location
		Z	Contacting 15X to the right, 30 cm (12 in) from front wall
16	On the ceiling, centered front to back, 30 cm (12 in) from right wall	X	Centered at nominal site location
		Z	Contacting 16X to the right, centered front to back
17	On the ceiling, 30 cm (12 in) from right wall and rear wall (square)	X	Centered at nominal site location
		Z	Contacting 17X to the right, 30 cm (12 in) from rear wall

longer tests utilized 10 s, 12 s, or 30 s time intervals due to the expected slow rates of change of the measured variables.

A data acquisition program developed at the Building and Fire Research Laboratory was used in conjunction with a computer. The program produces data files as follows: ascii test descriptions are placed at the top of the file, followed by digitized background readings, range calibration measurements, and finally the time dependent test data.

The reduction of data was performed with **RAPID [6]** software which was developed at NIST especially for fire tests. More details concerning the use of **RAPID** are available in the Phase I report [3]. **RAPID** requires an input data file of data collected by the data acquisition system and a program control file which contains the data channel descriptions and command instructions for data analysis. A sample program control file is included as Appendix C. The final output of the reduction process is a file containing the reduced data in columns. This file is readable by a variety of computer plotting and analysis programs. A complete set of the data in electronic form will be available through the CPSC.

Data plotting was performed on a Macintosh Centris 650 with Kaleidagraph version 3.0 software. The use of Kaleidagraph is described in the Phase I report [3]. A set of 11 plots was created for each test to visually inspect the time behavior of the measured variables. These plots are attenuation, carbon monoxide, selected hydrocarbons, ionization detectors, photoelectric detectors, site 11 gas sensors, site 7 gas sensors, site 9 gas sensors, temperatures near the food, selected temperatures on the range, and selected temperatures above the range surface. Similar plots for certain tests will be presented as examples in Section 3. Some data smoothing was employed to clarify general trends in the midst of large signal fluctuations. Smoothing is noted on the appropriate plots. A description of smoothing techniques is in the Phase I report [3].

## 3.0 Results

### 3.1 General Experimental Results

Selected plots of measured quantities are included in this section with notes regarding particularly interesting features. Primarily, results from baseline tests performed on the electric range A will be shown in this section. A discussion of **range** and hood effects is provided in Section 4.3. Statistical analyses of the test measurements are provided in Section 4. A small number of tests are used as examples because of the large total number of measurements for each of 42 tests. The trends are typical although there are some variations in detailed behavior and measured values from test to test. Important quantitative differences are addressed in Section 4.

### 3.2 Gas Concentrations

The results of gas-analyzer measurements for two tests are shown in Figures 5 and 6. Figure 5 is a plot of CO, CO<sub>2</sub>, and total-hydrocarbon concentrations versus time for a test of french-fried potatoes cooked in 500 mL of soybean oil. The concentrations of CO and CO<sub>2</sub> were measured on a dry basis (water removed). The concentration unit of parts per million is designated by ppm. The CO<sub>2</sub> concentration increased from an initial background level of 0.1%

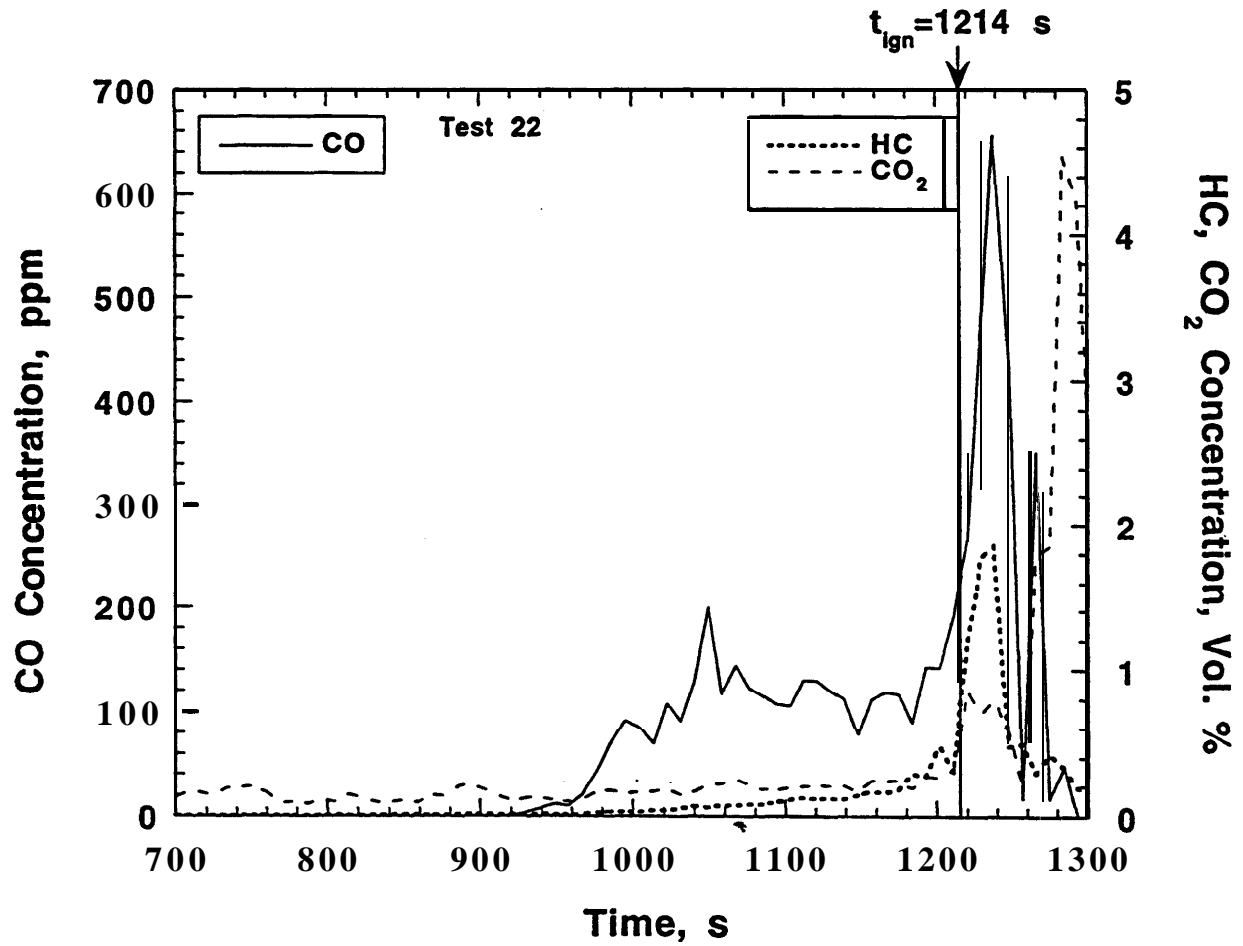

Figure 5. CO, hydrocarbon, and CO<sub>2</sub> concentrations versus time for **french-fried** potatoes in soybean oil (**normal**→**unattended**).

to about 0.3% before ignition. The CO concentration increased from 0 ppm to about 200 ppm with all of the rise occurring in the 300 s preceding ignition. The hydrocarbon concentration increased from 0% to 0.5% over about the same period as CO. After ignition, CO and hydrocarbon concentrations continued to rise because the lid used to smother the fire increased interior pan and food temperatures and thus smoke production. The late peak of CO concentration reflects the use of the fire extinguisher to cool the pan and **extinguish** reignitions.

Figure 6 shows the corresponding results for a test of blackened catfish. The ignition line appears delayed relative to the analyzer signals because for this particular test, the food ignited about 30 s after the pan was removed from the hot burner and placed on a cold burner away from the gas sampling probe. The CO<sub>2</sub> concentration remained near its background level through 480 s when the pan was removed from the heat. No extinguisher was used so the CO<sub>2</sub> level remained low. The CO concentration increased **from** 0 ppm initially to about 1200 ppm at 480 s with most of the rise occurring after 380 s. The hydrocarbon concentration increased from 0% to 2% between 240 s and 480 s.

### 3.3 Gas-Sensor Responses

There are a larger representation of gas-sensor plots included compared to any other sensor type because there were 25 individual gas sensors. The focus of the figures is on those sensors that were located along the plane of symmetry of the range and responded with relative strength. The plots show sensor output voltage versus time. Output voltages have had initial background voltages subtracted from them. The responses of the hydrocarbon- and alcohol-gas sensors at sites 7, 9, and 11 for a test of french-fried potatoes cooked in 500 mL of soybean oil are shown in Figures 7, 8, and 9. The water-vapor and CO-sensor responses for the same sites and test are shown in Figure 10. In each plot, the responses to the introduction of the fries to the hot oil at 285 s are shown. Figure 11 shows the responses of the hydrocarbon sensors at site 9 for a blackened catfish test with no ignition. Figure 12 shows the responses of the hydrocarbon sensors at site 9 for unattended chicken in 500 mL of soybean oil.

### 3.4 Smoke-Detector Responses

The two kinds of smoke detectors had **different** cooking condition responses as they reached **alarm** states. The photoelectric detectors simply changed from a **nonalarm** zero voltage value abruptly to an alarm-state voltage of 5 V. Figure 13 shows the output signals for all of the photoelectric detectors versus time for a french-fries test. The ionization detectors reacted in a gradual fashion related more closely to the amount of smoke contacting them. When the voltage output crossed zero and became negative, the alarm was activated. Figure 14 shows the output signals for the four ionization detectors for the same french-fries test. Figures 15 and 16 are the corresponding plots of photoelectric and ionization detector outputs for a broiled-steak test.

### 3.5 Temperatures

The plots of temperature are divided into two categories: near the pan or food, and on the range upward to the range hood.

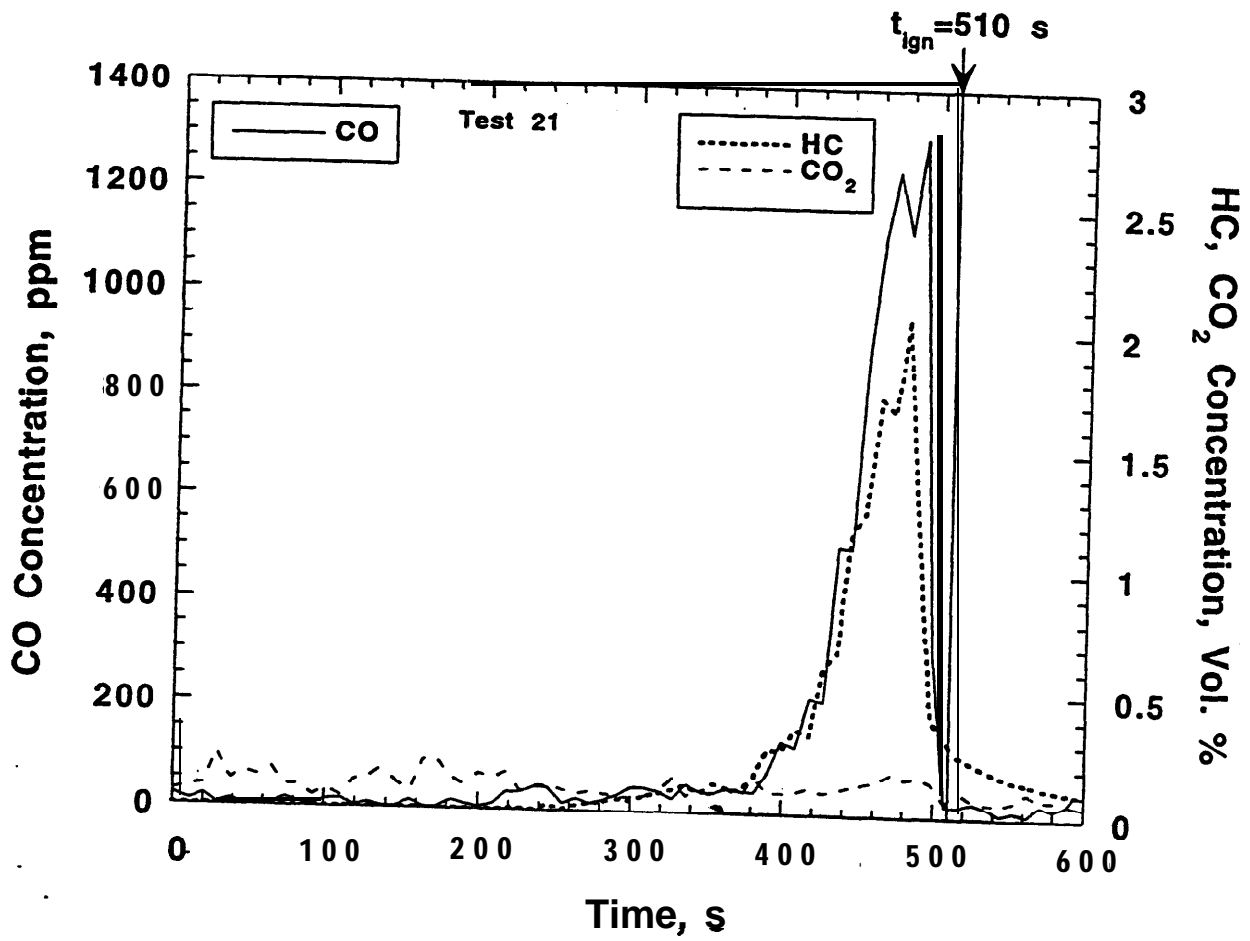

Figure 6. CO, hydrocarbon, and CO<sub>2</sub> concentrations versus time for blackened catfish (normal).

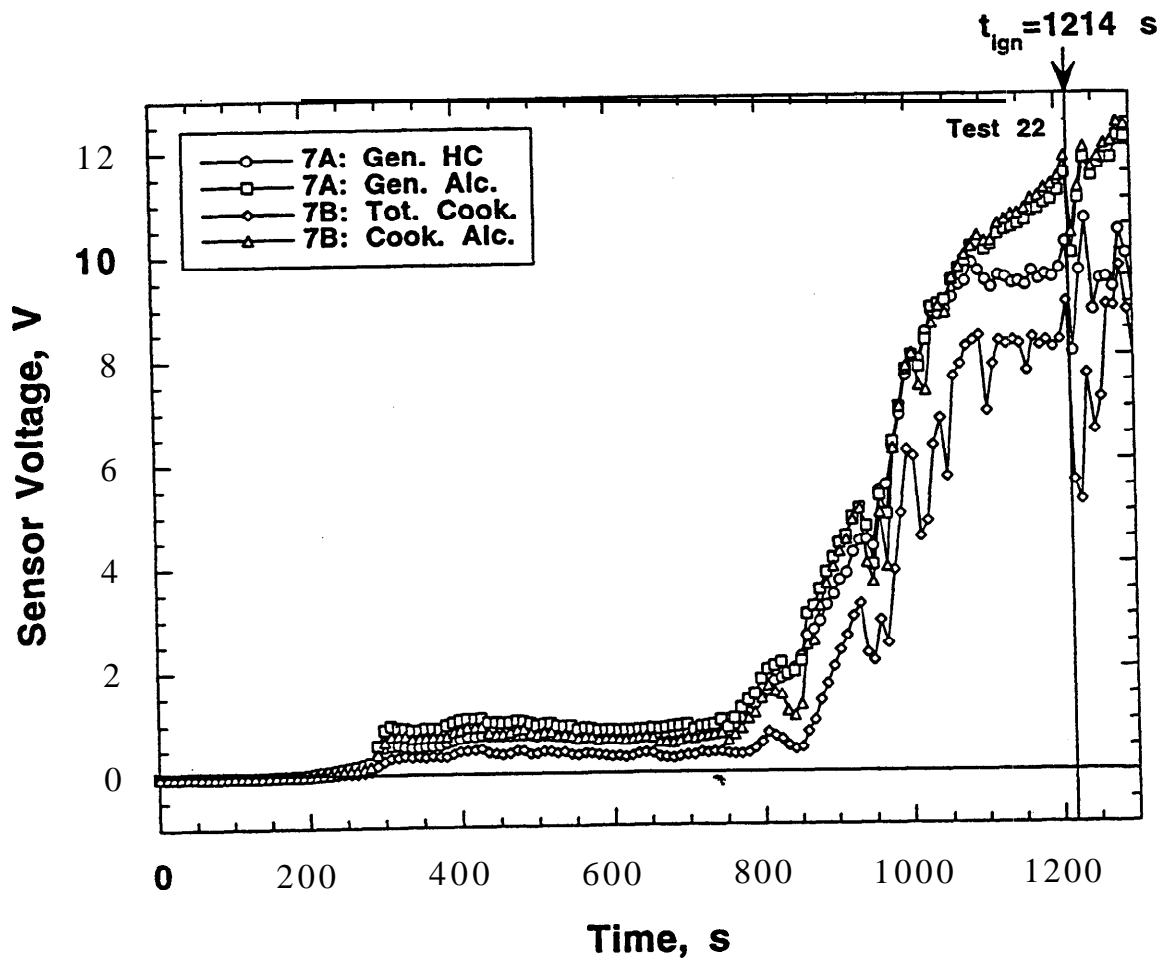

Figure 7. Site 7 hydrocarbon-sensor responses versus time for **french-fried** potatoes in soybean oil (**normal**→**unattended**).



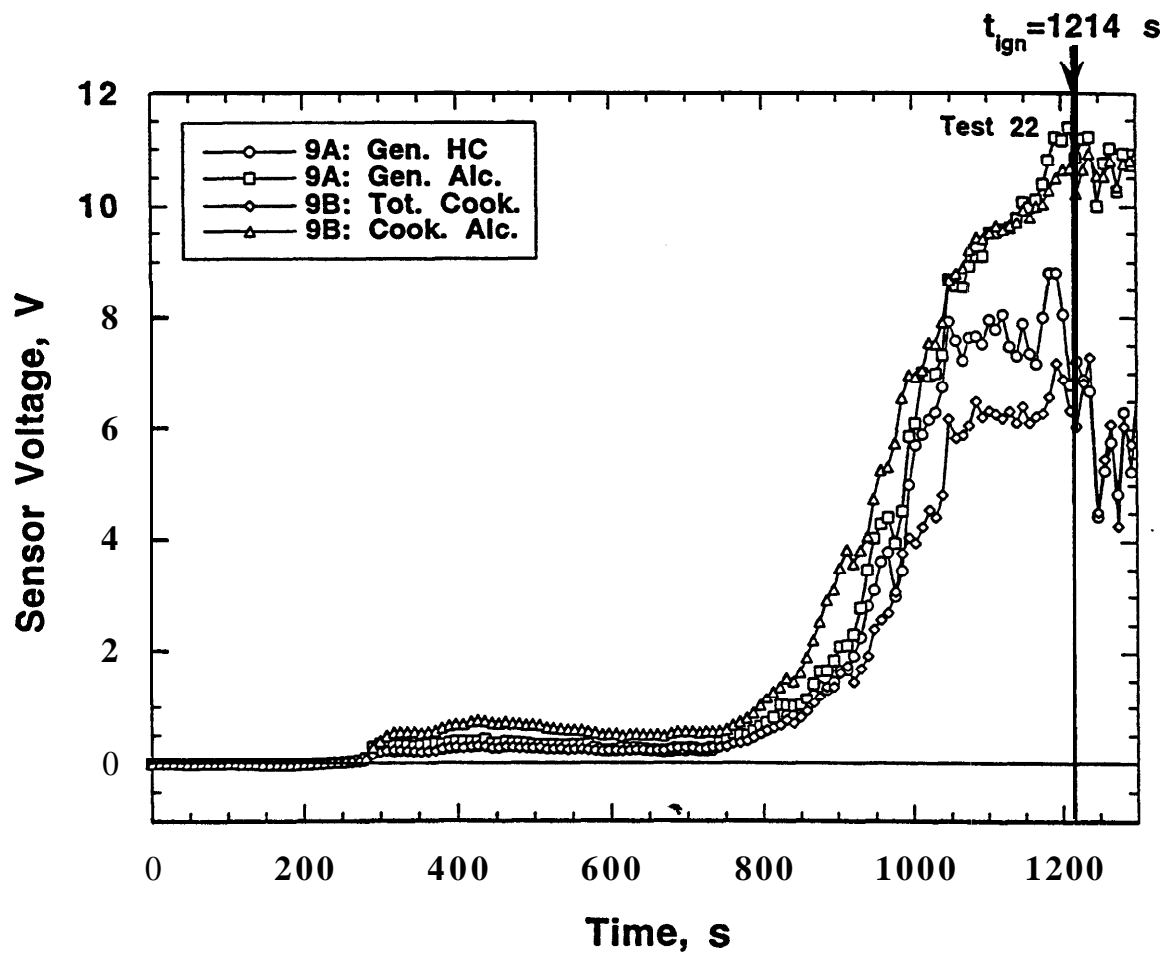

Figure 8. Site 9 hydrocarbon-sensor responses versus time for **french-fried** potatoes in soybean oil (**normal**→**unattended**).

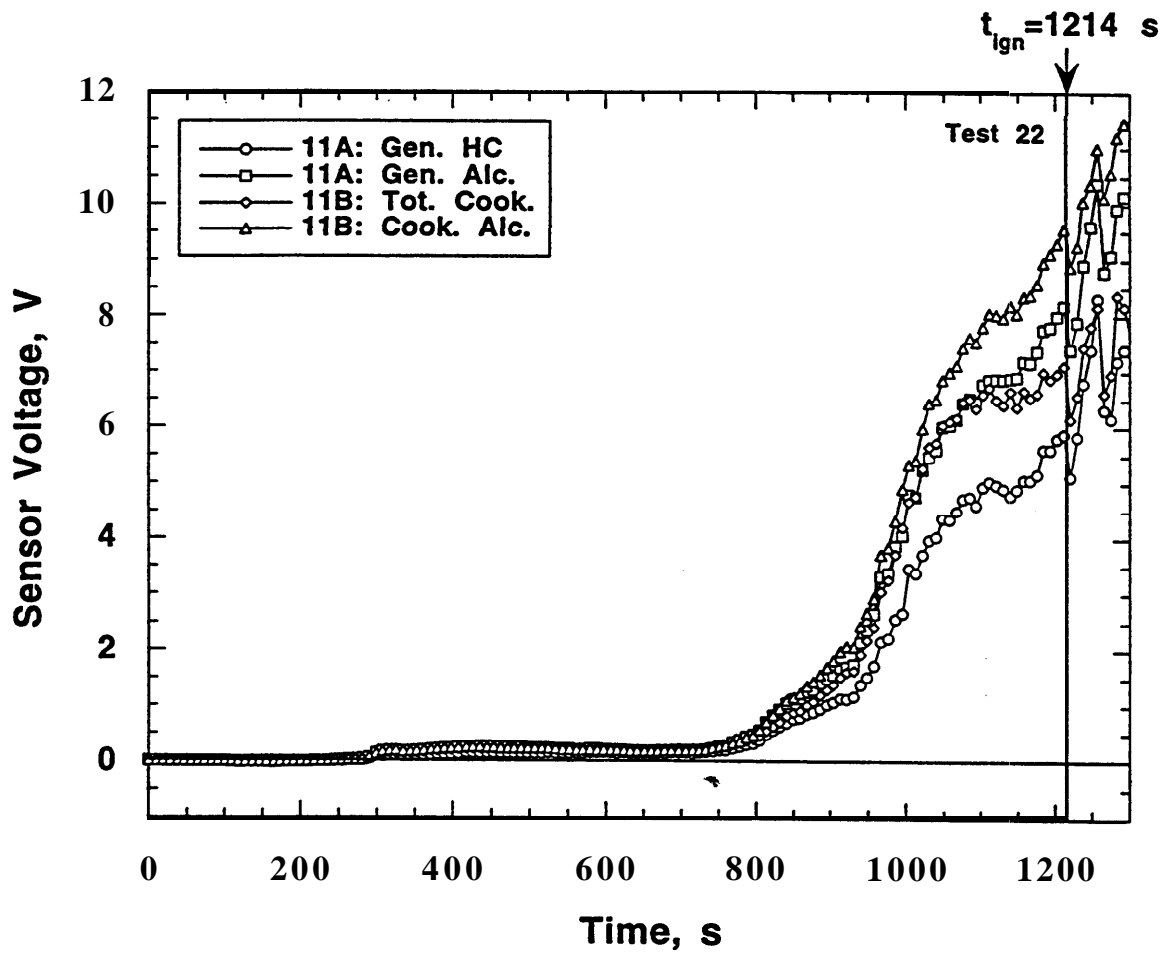

Figure 9. Site 11 hydrocarbon-sensor responses versus time for **french-fried** potatoes in soybean oil (**normal**→**unattended**).

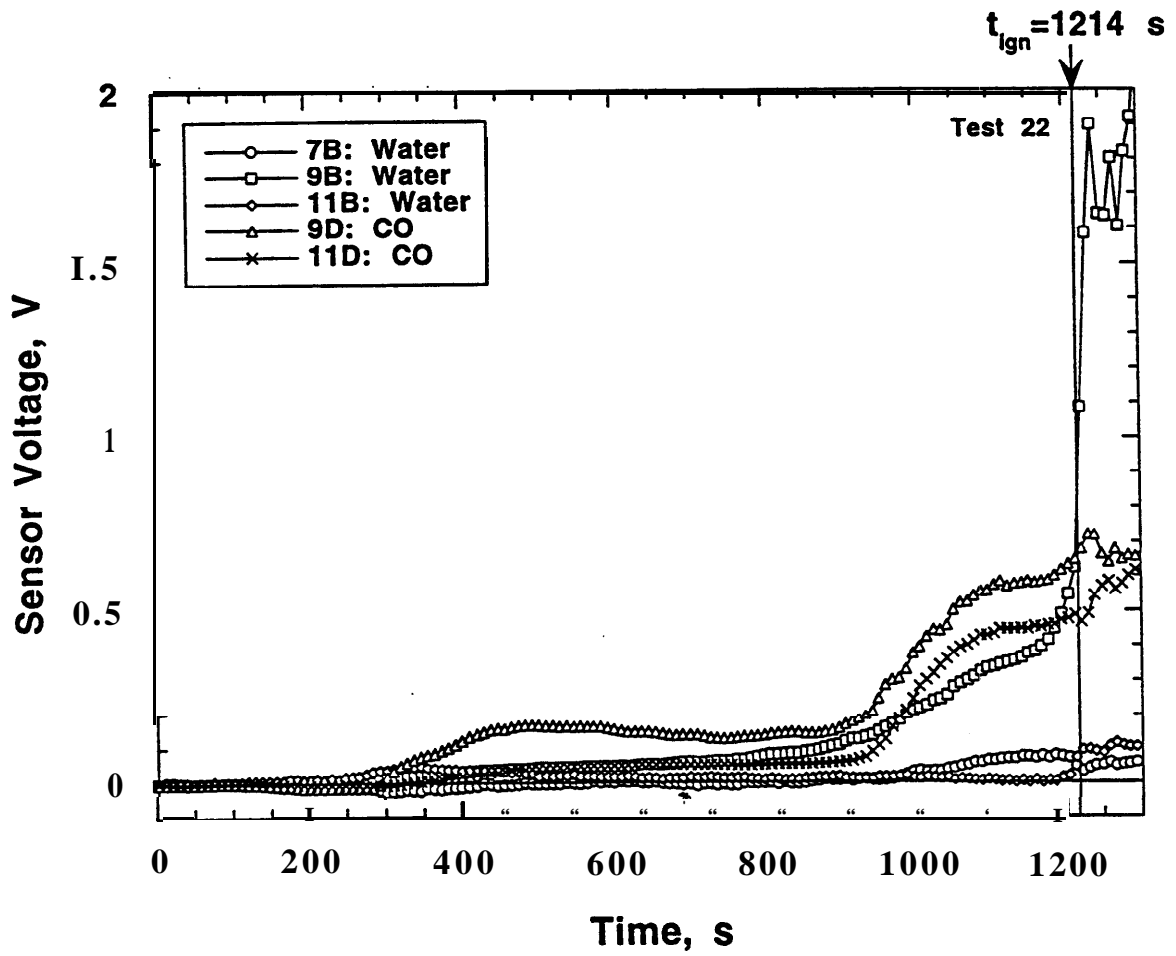

Figure 10. Sites 7, 9, 11 water-vapor and CO-sensor responses versus time for french-fried potatoes in soybean oil (normal→unattended).

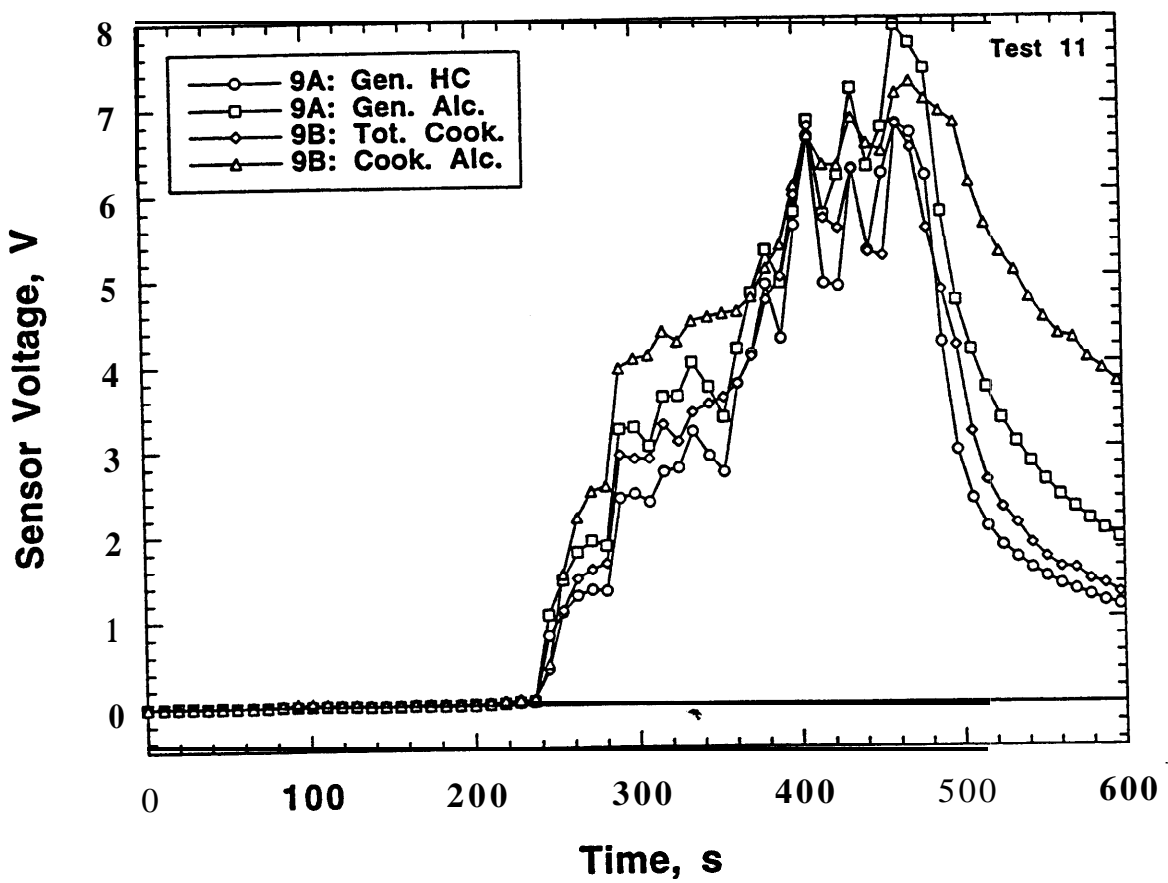

Figure 11. Site 9 hydrocarbon-sensor responses versus time for blackened **catfish** (normal).

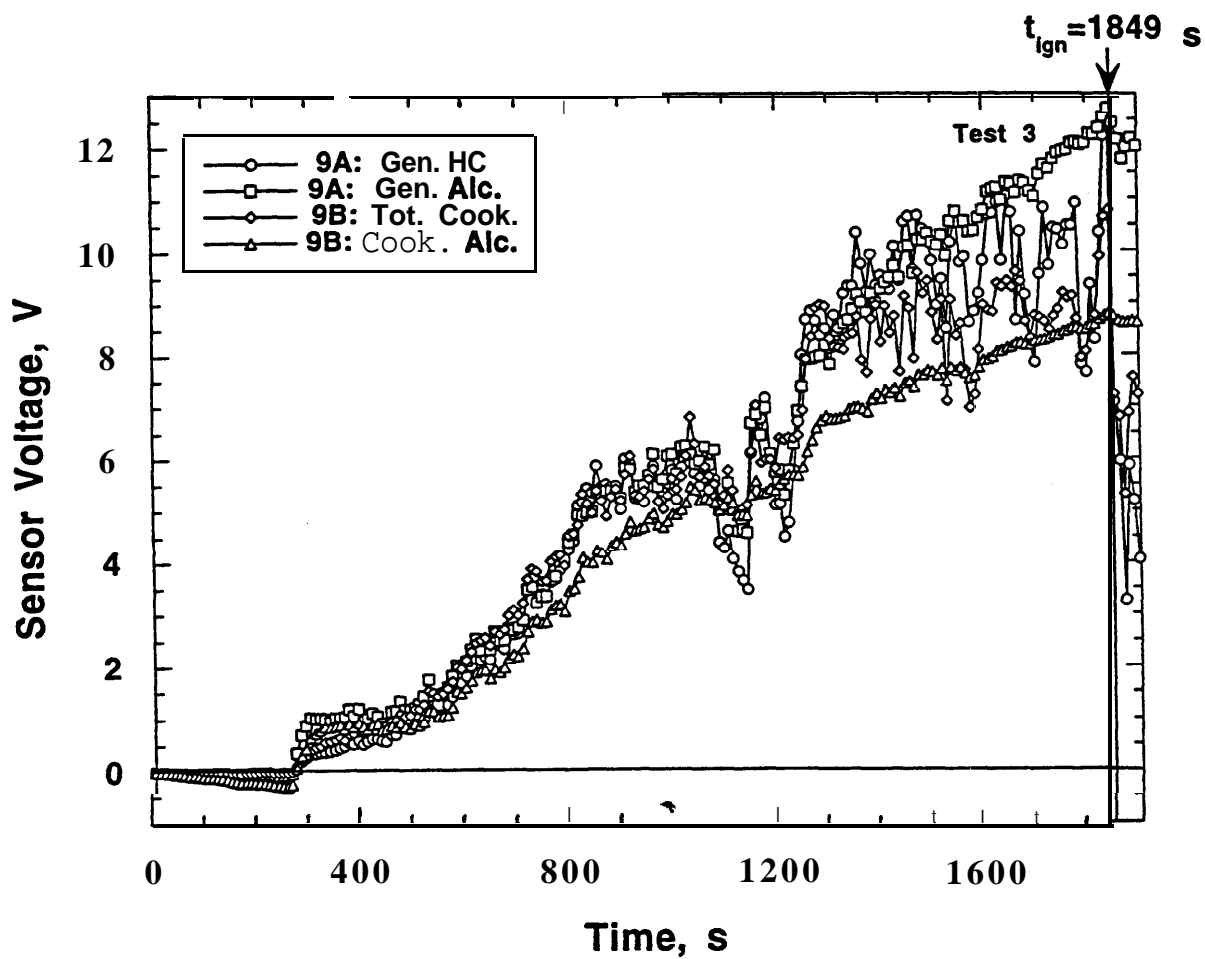

Figure 12. Site 9 hydrocarbon-sensor responses versus time for chicken in soybean oil (unattended).

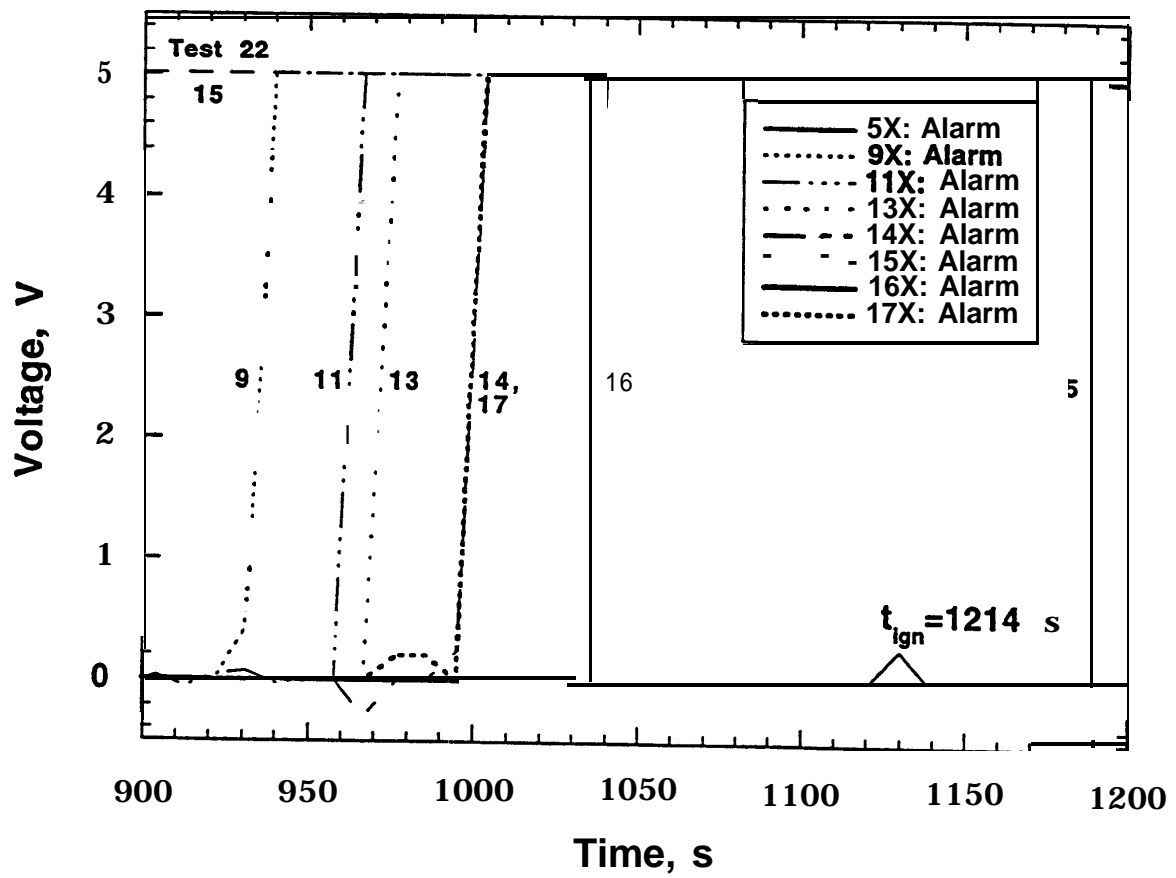

Figure 13. All photoelectric detector **alarm** signals versus time for **french-fried** potatoes in soybean oil (**normal**→**unattended**).

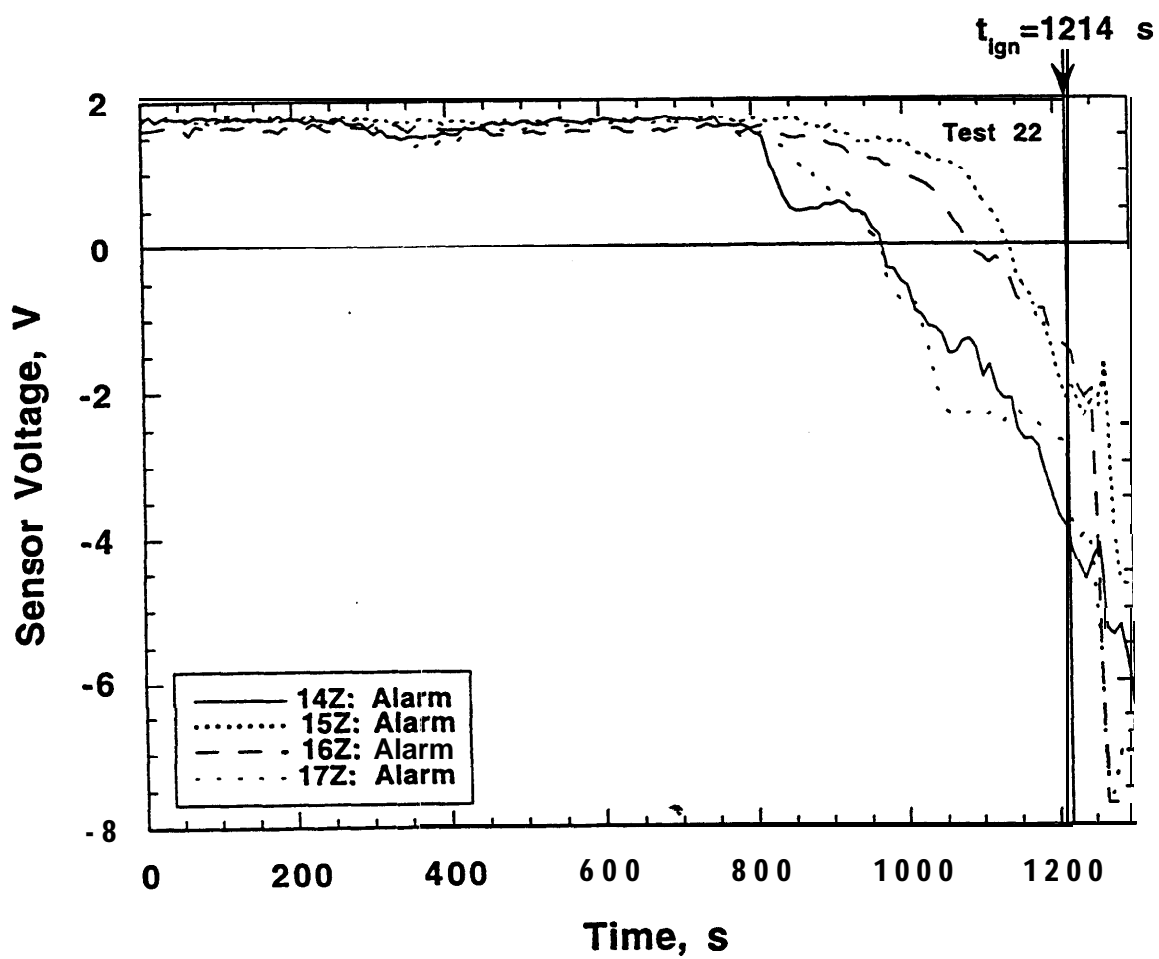

Figure 14. All ionization detector alarm signals versus time for french-fried potatoes in soybean oil (**normal**→**unattended**).

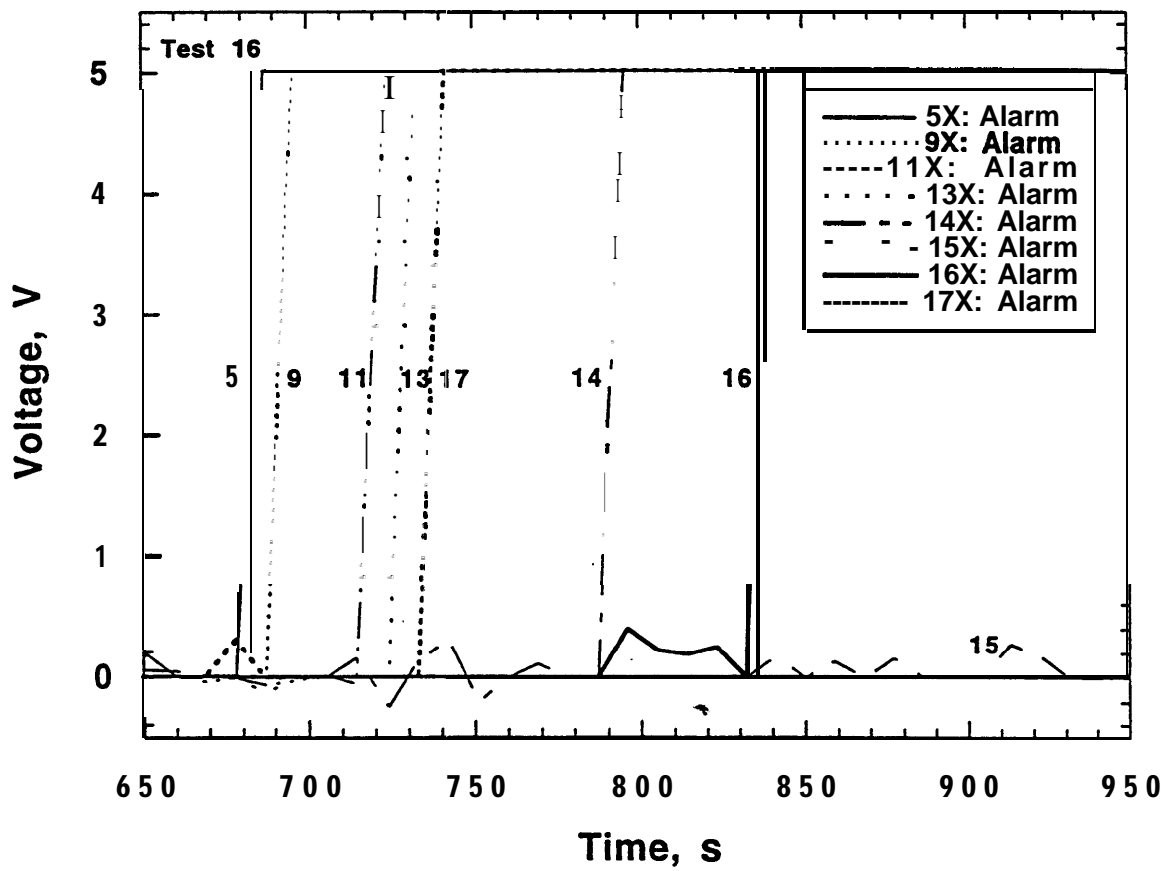

Figure 15. All photoelectric detector alarm signals versus time for broiled steak (normal).



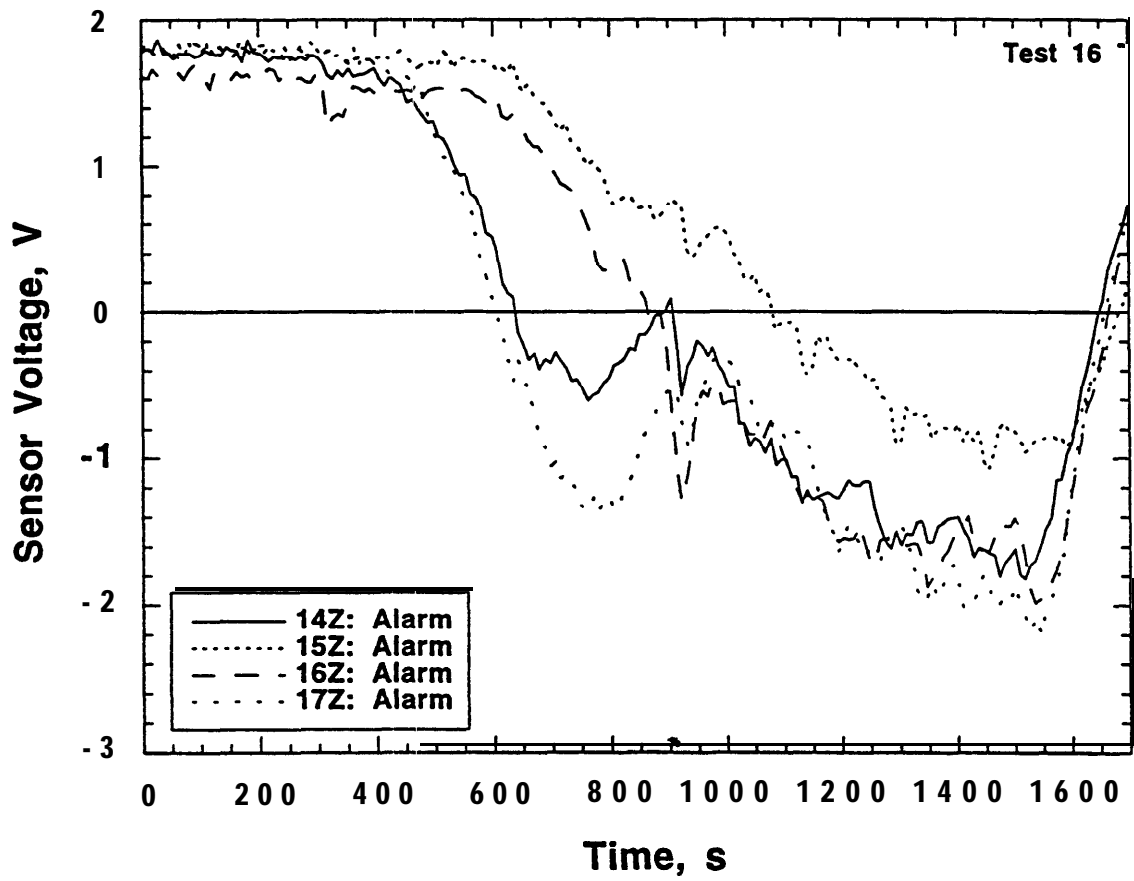

Figure 16. All ionization detector alarm signals versus time for broiled steak (normal).

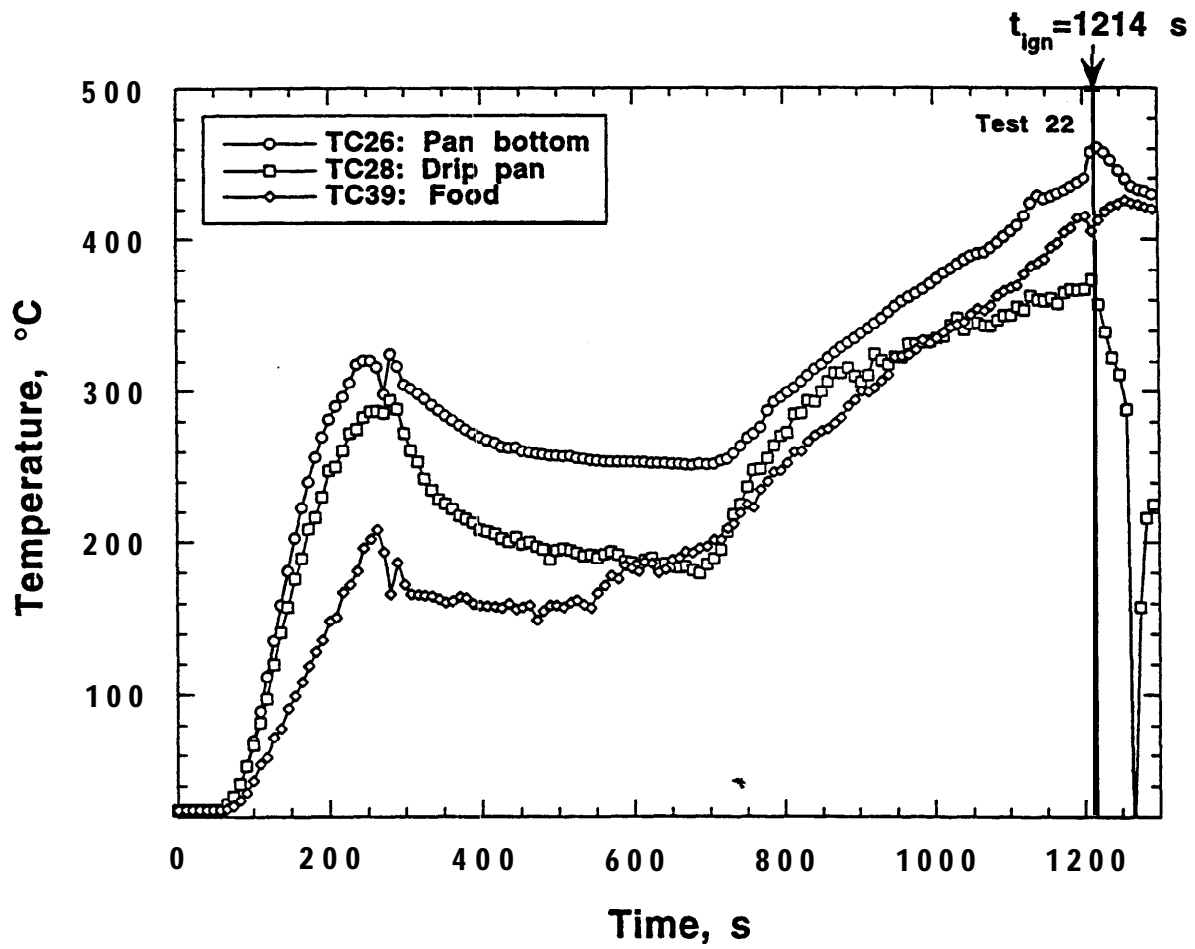

Figure 17. Temperatures near the pan versus time for french-fried potatoes in soybean oil (normal→unattended).

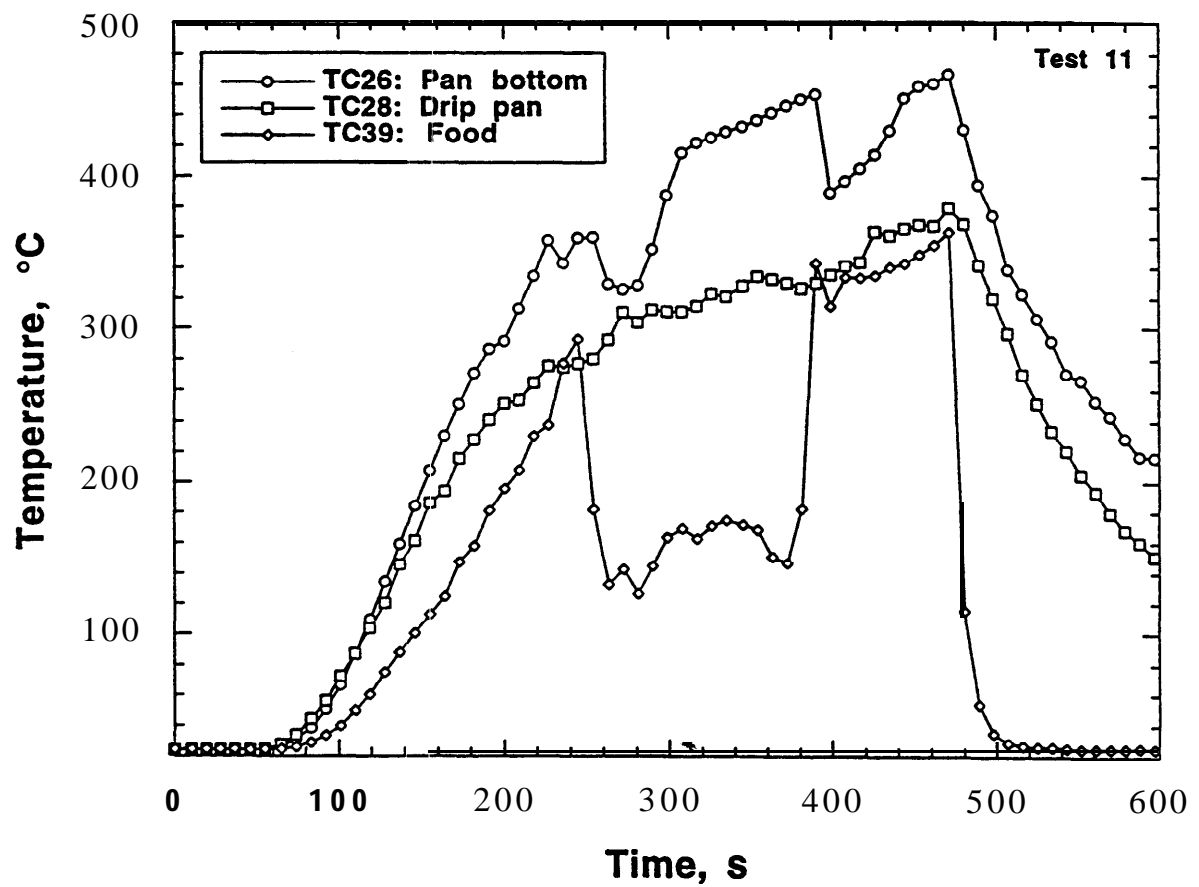

Figure 18. Temperatures near the pan versus time for blackened catfish (normal).

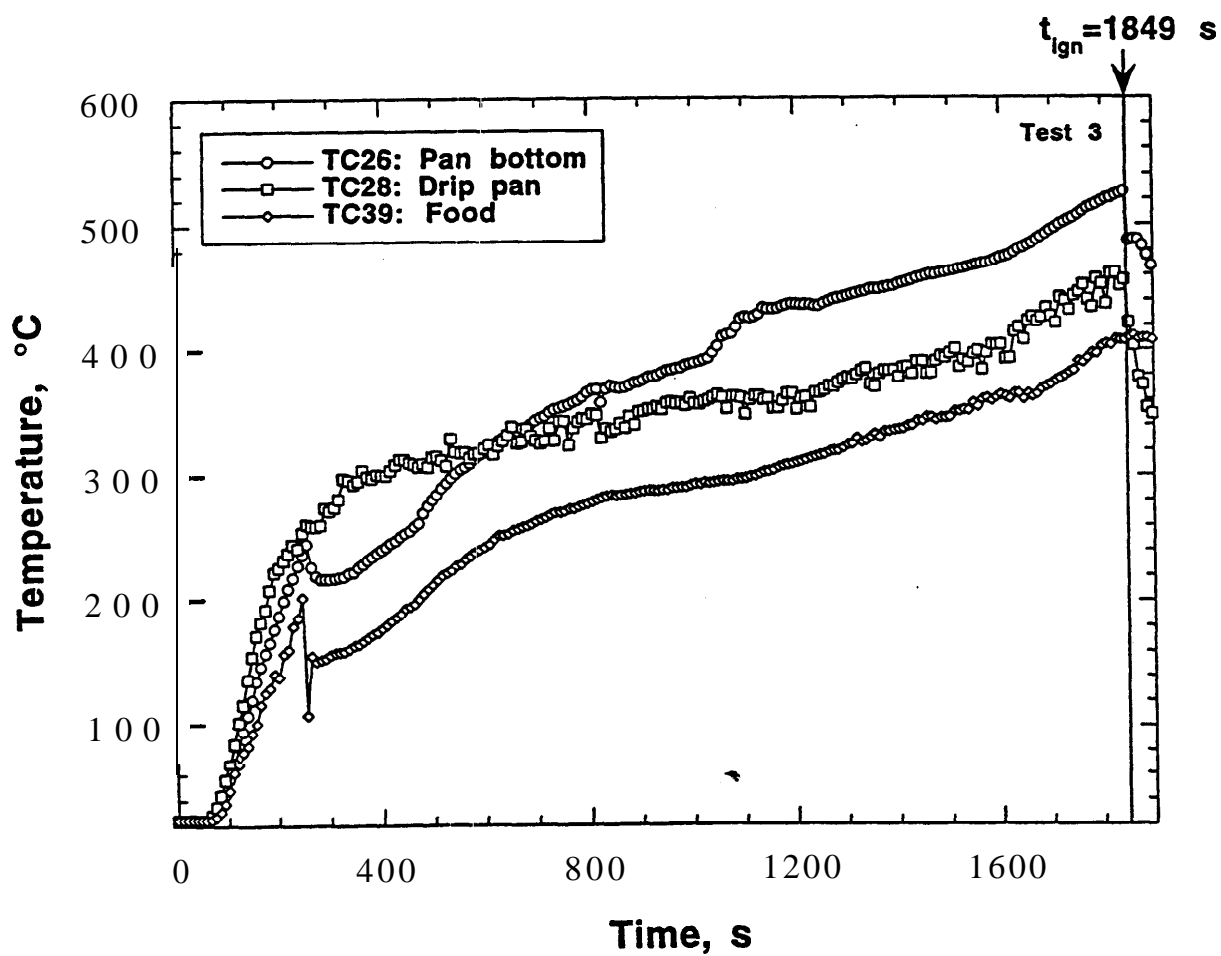

Figure 19. Temperatures near the pan versus time for chicken in soybean oil (unattended).

### 3.51 Pan and Food

Figure 17 shows a plot of three thermocouple responses versus time for a **french-fried-potatoes** test. Numbered thermocouples and their corresponding locations are described in Appendix C. Thermocouple 26 measured the temperature on the pan bottom. Pan temperatures often increased following ignition because the thermocouple remained in contact with the pan after the lid was put in place which trapped additional heat in the pan and raised its temperature. Thermocouple 26 malfunctioned for portions of tests 24-32. Thermocouple 28 was located near the center of the drip pan under the burner. Thermocouple 39 was located in the food itself. Since the food thermocouple was not fixed in the pan, temperature plots often show fluctuations due to stirring or turning of the **food** which exposed the thermocouple to relatively colder or hotter local areas. Figures 18 and 19 show the corresponding three temperature-time histories plotted for the cases of **catfish** and chicken in oil (unattended), respectively. The lower food temperature beginning at about 250 s in **Figure 18** was due to the introduction of the fish into the pan.

### 3.5.2 Range and Range Hood

Figure 20 shows a plot of **thermocouple** responses versus time associated with the range for a **french-fried-potatoes** test. Thermocouples **19, 22,** and 23 were located on the center of the range surface, at the center of the front edge, and in the right front corner near the focus burner, respectively. Thermocouples 29 and 30 were located underneath the drip pan of the focus burner and underneath the range surface at the center of the range, respectively. The sharp drop **in some** temperatures after ignition was due to the cold gas from the **CO<sub>2</sub> fire** extinguisher. Figure 21 shows thermocouple responses from above the range for the same test. Thermocouple 9 was located at site 9 with the gas sensors on the center of the front of the range hood. Thermocouple 35 was located under the right-side hood filter. Thermocouple 40 was located just below the end of the gas-sampling probe. Figures 22 and 23 show results for the same locations as in Figures **20** and **21** except that they were produced by a test of water on three burners with the oven on and oil on the focus burner. Also, thermocouple 31 on Figure 22 shows the additional trace of the oven temperature which exhibited a cycling behavior.

## 3.6 Laser Attenuation and Scattering

Figures **24** and **25** show laser-attenuation measurements versus time for tests of **french-fried potatoes** and water and oil, respectively: The circles represent the actual data points, and the curves were generated by partially smoothing the data. A 2% smooth, for example, replaces a data point with a point generated from a least-squares **curve** fit through the original point and the surrounding 2% of all of **the** data. Light-scattering measurements were found to be impractical due to very low **signal-to-noise** ratios.

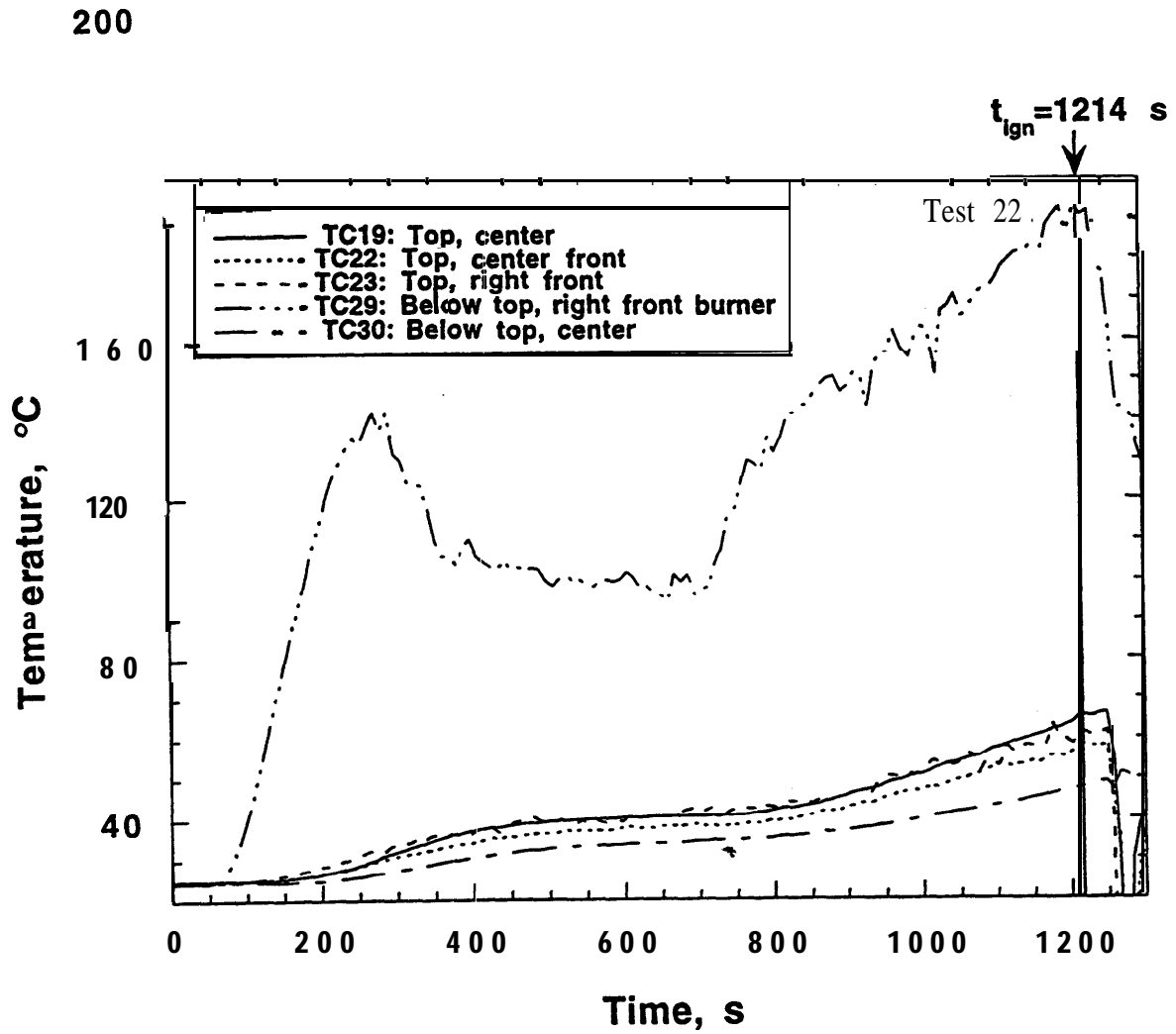

Figure 20. Temperature of the range versus time for **french-fried** potatoes in soybean oil (normal→unattended).

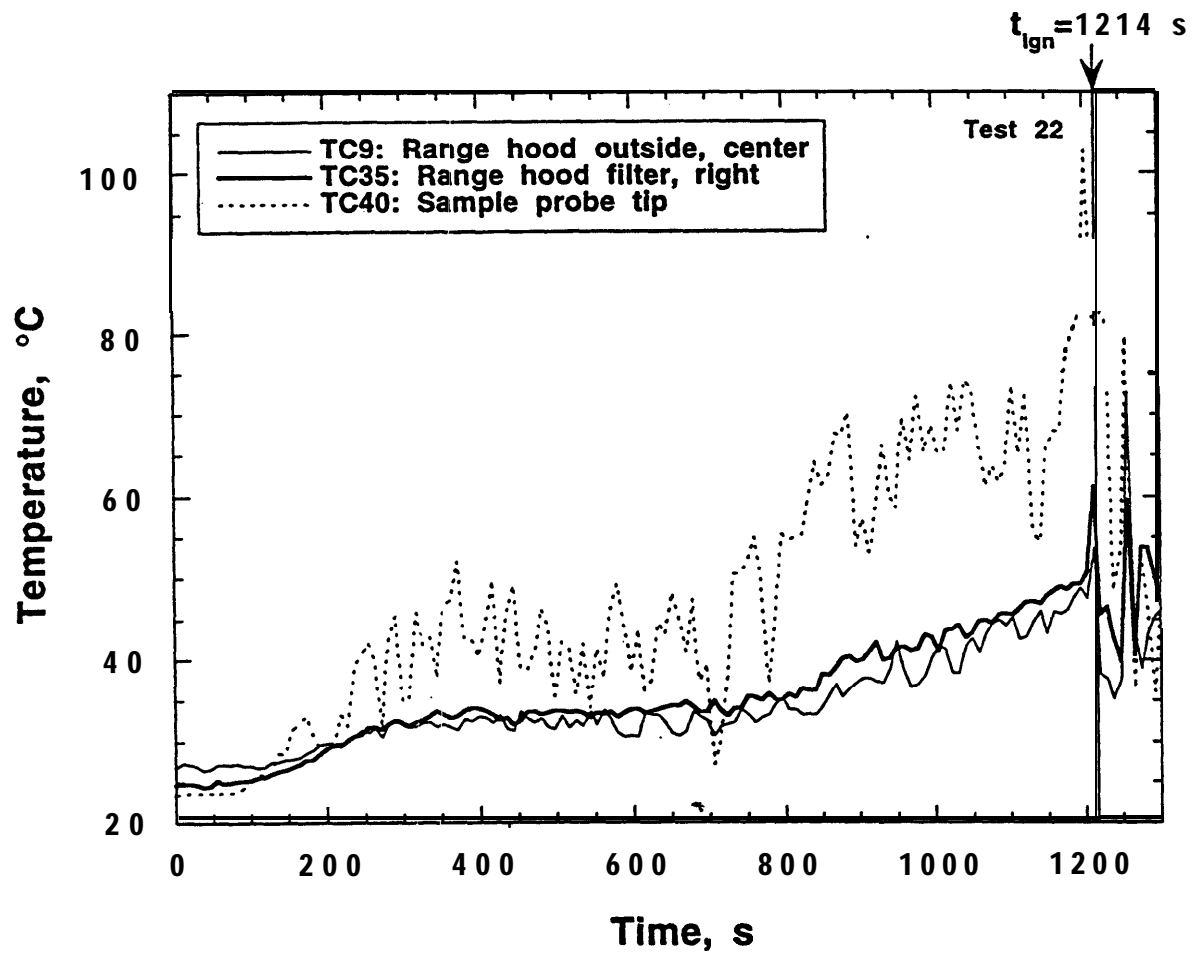

Figure 21. Temperatures above the range versus time for french-fried potatoes in soybean oil (normal→unattended).

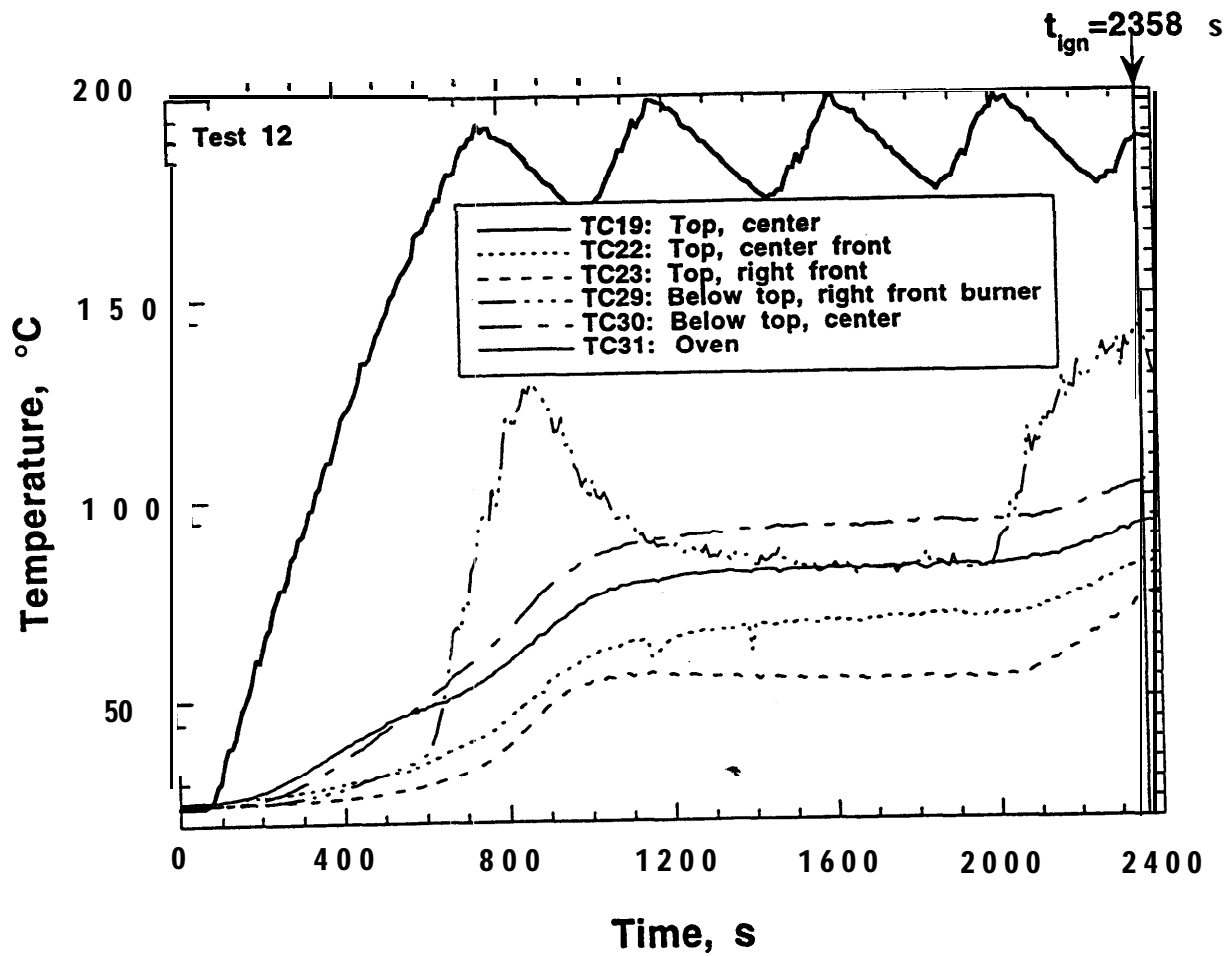

Figure 22. Temperatures of the range versus time for water and oil (normal→unattended).



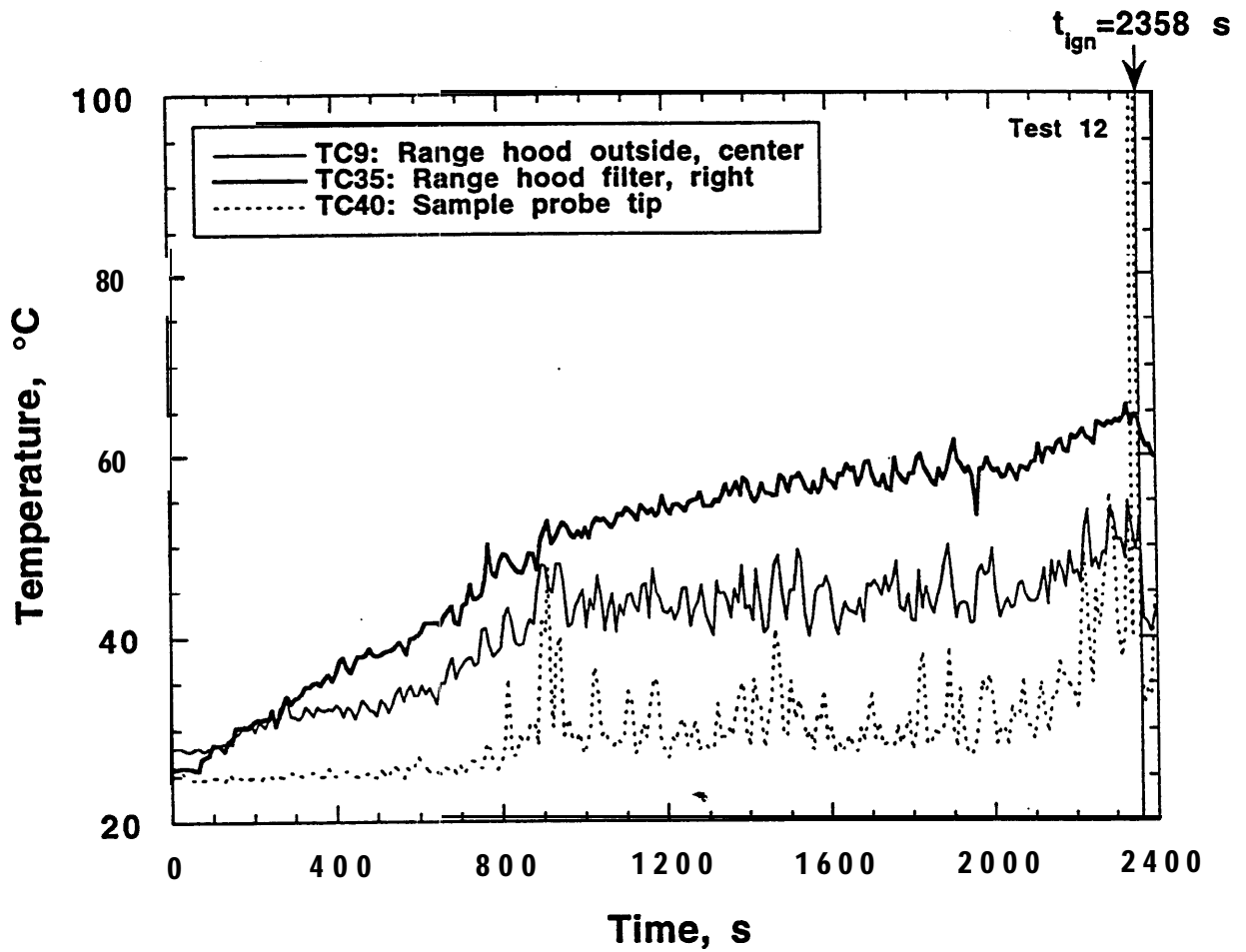

Figure 23. Temperatures above the range versus time for water and oil (normal→unattended).

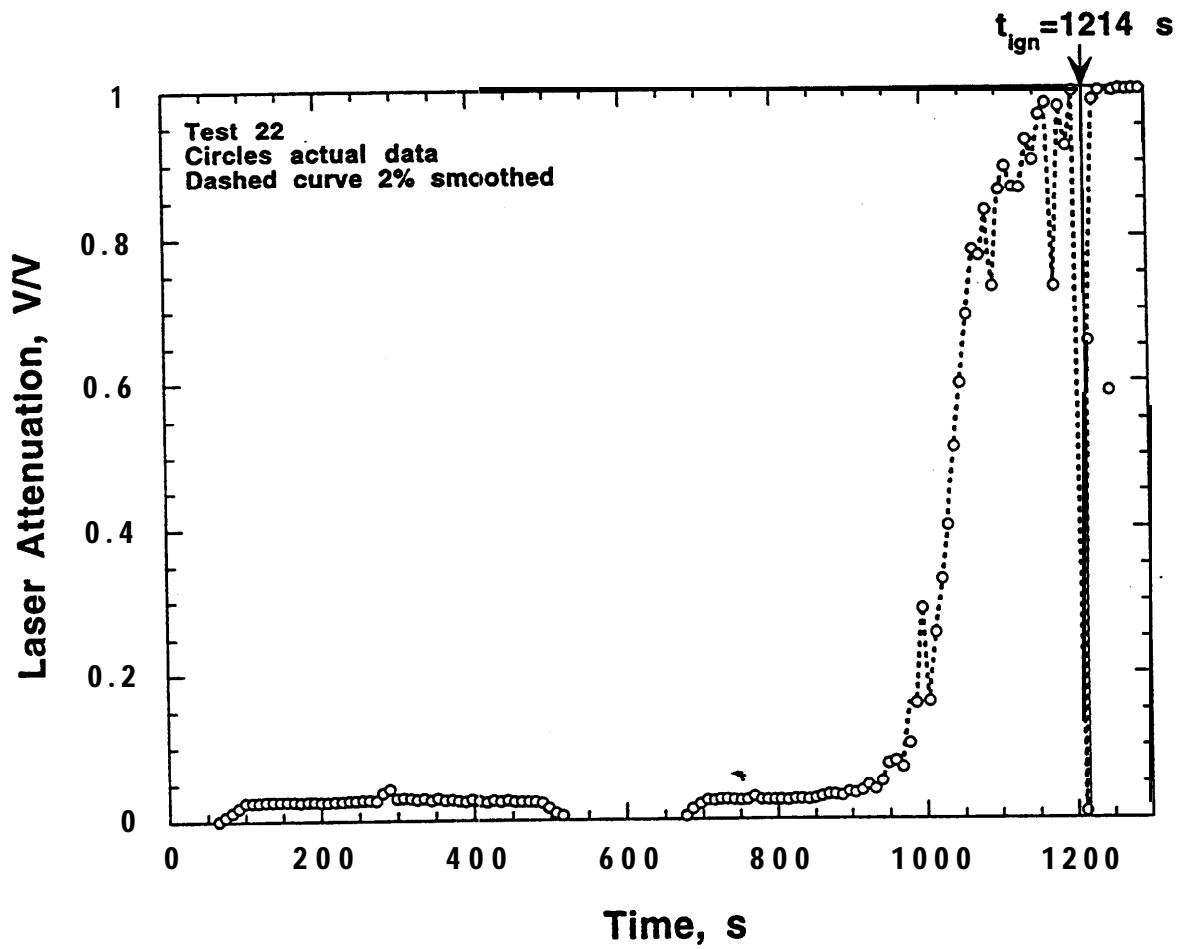

Figure 24. Laser attenuation **versus** time for french-fried potatoes in soybean oil (normal→unattended).

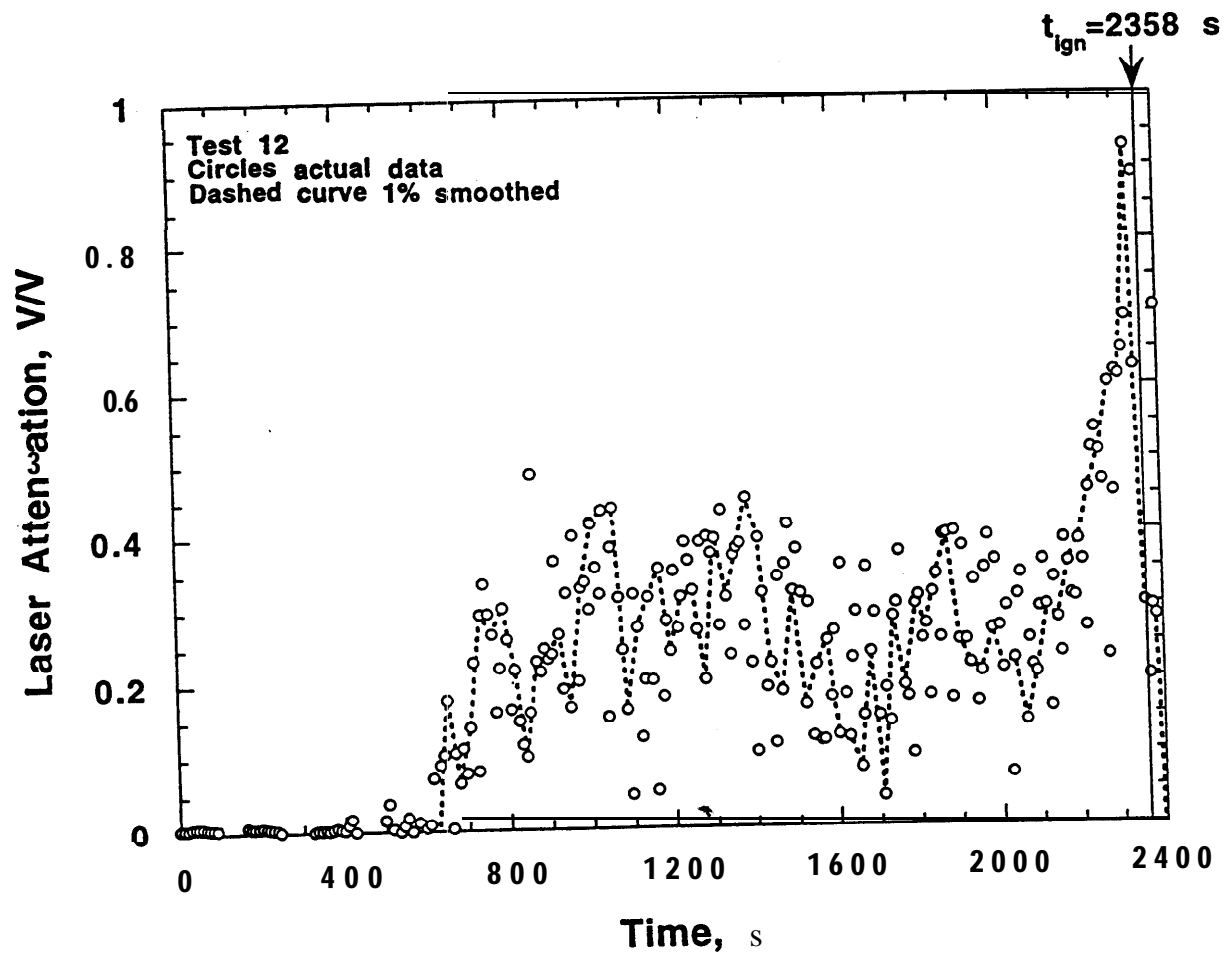

Figure 25. Laser attenuation versus time for water and oil (normal→unattended).

### 3.7 Recorded Images

The videotape recordings provide considerable qualitative and quantitative details concerning the tests. The instants of ignition are clearly defined, allowing more exact times **and** modes of ignition to be determined. The recordings are also useful for characterizing the depth and thickness of the smoke layer for each experiment.

A total of 120 slide photographs were taken for this experimental series. The slides portray the experimental apparatus, cooking phenomenon, and pre- and post-test images of the food.

## 4.0 Analysis and Discussion

### 4.1 Analysis Techniques

Table 2 lists the tests and their corresponding designations as normal, unattended, or both. Depending on the designation, times for ignition and times chosen as normal are listed as well for each test. The normal times are when the heating period of a test was concluded or when the unattended portion of a test began. A few unattended tests (10, **14**, **33**, **35**, and 37) did not lead to ignition, but the times when heating was stopped were used as ignition times. These tests were among those performed for the cases of stir-fry vegetables, macaroni and cheese, and oil and water (with the gas range). This was done because the levels of smoke and/or melting of metal were judged sufficiently undesirable or potentially dangerous enough to warrant designating the situations as alarm-worthy.

The normal and ignition times were used for each test to perform analyses. Since the identification of a detection window, or distinct **difference** between normal and ignition conditions, for all tests is the objective, the maximum measured values during the normal cooking periods and the minimum measured values in the 30 s (and sometimes 60 s for comparison) preceding ignition were calculated for every variable. In figures to follow, these are designated by "**nMax**" and "**i30Min**", respectively. The minimum was the data point of least value of typically three or four points **from** the 30 s period. The normal maximum values were the highest levels that occurred during normal cooking. Minima and maxima were used rather than averages in order to capture the sensor signals that would be employed by an actual detection system including noise or fluctuations inherent in the measurements. Table 2 lists the normal and ignition times used for the data **analysis**.

Unless otherwise stated, all of the minima are from the 30 s preceding ignition. Thirty seconds was chosen as the pre-ignition time of primary focus based on the cooling-lag test on electric range A which indicated an 11 s delay before food and pan-bottom temperatures began to decrease after power was cut off. Figure 26 shows the pan-bottom and food temperatures versus time for the cooling-lag test. Thirty seconds provides nearly 20 s of additional time preceding ignition as an added safety factor.

Most of the measurements showed that the variables sensed did not generate signals that would be useful inputs for a **pre-fire** detection system. They showed insufficient or no differentiation between normal and pre-fire conditions so they have no potential as detection

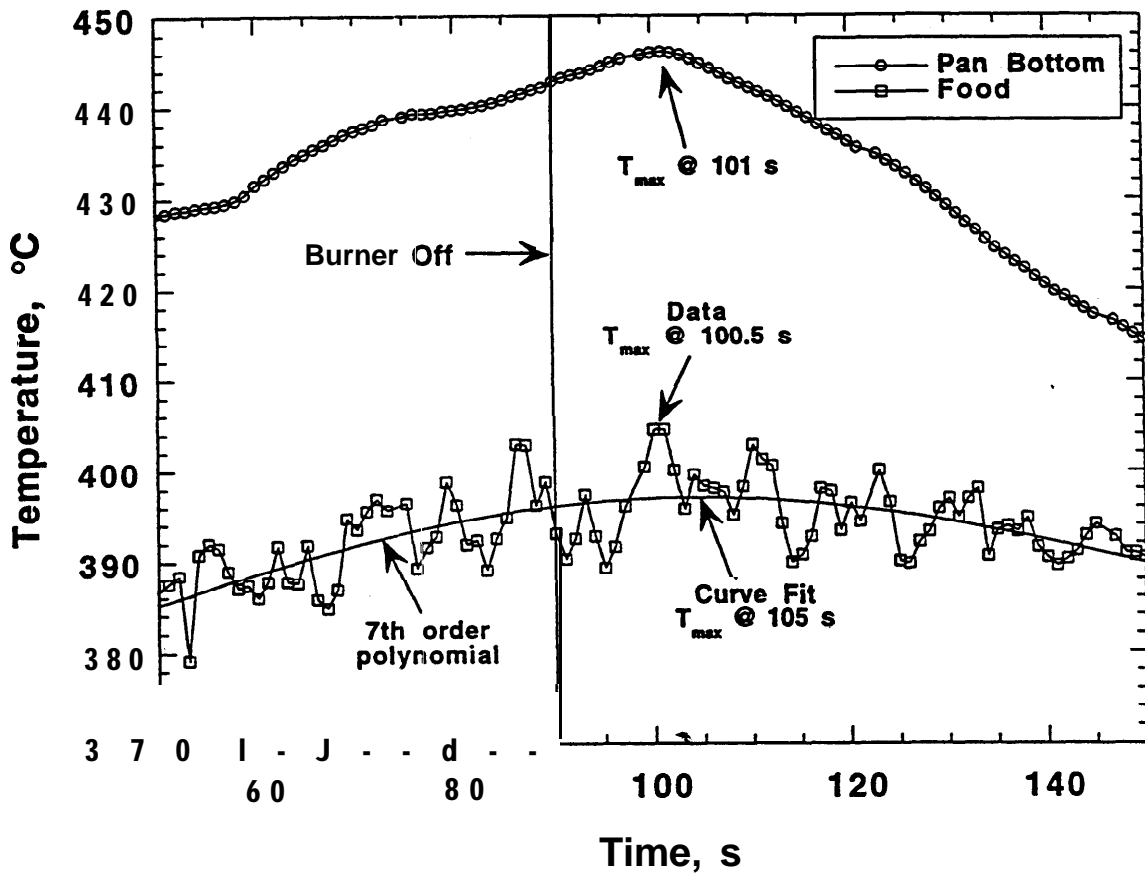

Figure 26. Pan-bottom temperature and food temperatures versus time for cooling-lag test of 500 mL oil on the **type-A** electric range.

devices at their specific locations. Instruments such as the laser-attenuation system and gas analyzers are not candidates for detector components because of their bulk and expense. The focus of analysis, therefore, was placed on the sensors located along the plane of symmetry of the range to see if single sensors alone could **successfully** provide coverage across the width of the range. Less focus was given to sensors off of the plane of symmetry because a detection system requiring localized coverage by 2 or 4 sensors of each type would be prohibitive due to higher costs and complexity. Performance results for gas sensors, thermocouples, and smoke detectors are summarized in Sections 4.2.1 through 4.2.4.

#### 4.2 Detection Potential of Devices

The following list of questions was generated through discussions between **NIST**, CPSC, and range-industry representatives. The questions reflect important considerations in the evaluation of the detection success and implementation potential of the devices.

1. Does detection occur with **sufficient** time for the actuation of a shutoff device and cooling of the area so ignition cannot occur?
2. Does the device **function** consistently with the range hood on and **off**?
3. Does the device fail to respond to normal conditions, or not generate false alarms?
4. Can the device be exposed to a kitchen environment, especially contaminants, with a rate of deterioration in performance consistent with 20 years of range life expectancy?
5. What is the probable capability in reducing food fires?
6. How easily can the device be: incorporated into a new **range/cooktop**?
7. Is the device **useful** as a retrofit, as a new component, or as an external independent device?
8. What is the cost of the device as purchased, and what might be the mass produced costs, costs for range installation, or costs for modification as retrofits available from manufacturers or suppliers?

Points 1-5 are addressed in the following sections, and the NIST study especially focuses on points 1-3. Points 6-8 should be dealt with through the engineering development of a detection system.

##### 4.2.1 Gas Sensors

**Figures 27** and **28** are examples of sensor outputs that were found not to be especially **useful** for discriminating between **normal** and pre-ignition conditions. Figure 27 shows the normal maxima and pre-ignition minima for the total-cooking-gas sensor at site 6, which was located behind the focus burner on the splash panel of the range. On the plot, the individual test numbers are on the independent axis. Since the gas burner of focus was located on the opposite side of the range from the primary electric burner, data from the site 4 sensor replaced the site 6 data for the gas-range tests. The signals were generally weak with no clear separation between normal and pre-ignition conditions. This result was due to the relatively low height of the sensor above the range surface which prevented exposure to the majority of the cooking gases.

Figure 28 shows the response of the CO sensor located on the range hood at site 9. The regions of maximum normal points and minimum ignition points overlap substantially. For an

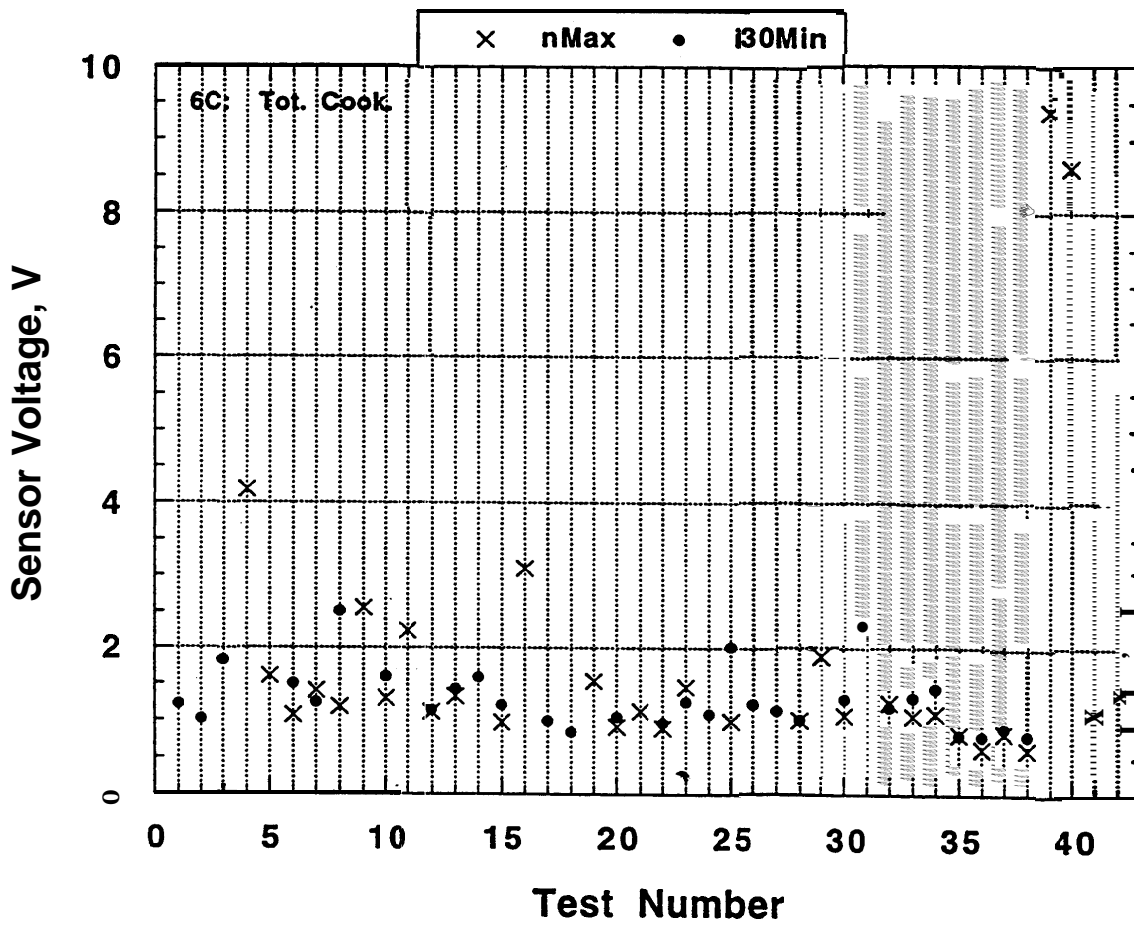

Figure 27. Site 6 total-cooking-gas sensor maximum normal and minimum ignition output 30 s before ignition versus test number. Data for the gas-range tests (35-38) are from the site 4 total-cooking-gas sensor.

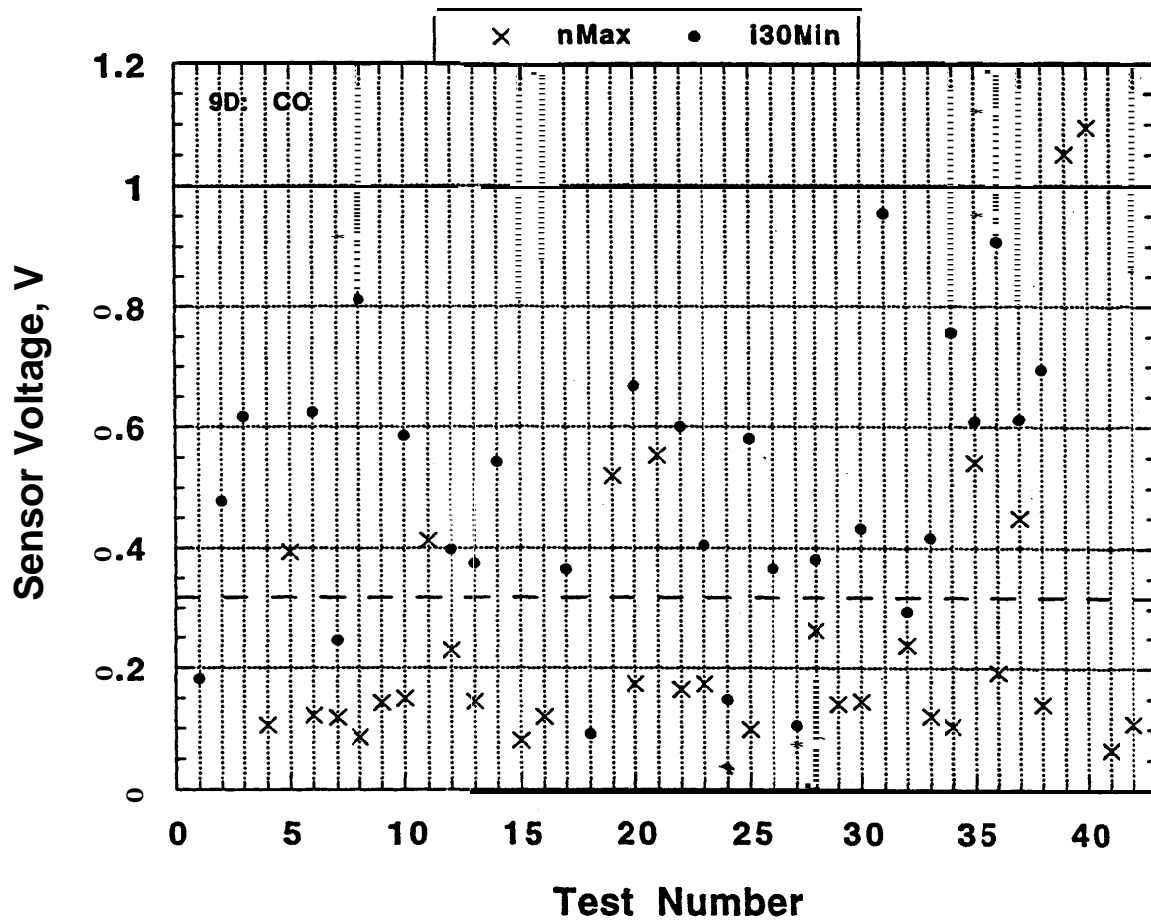

Figure 28. Site 9 carbon monoxide sensor maximum normal and minimum ignition output 30 s before ignition versus test number.



alarm threshold of 0.32 V, the sensor generated a 25% false-alarm rate and 20% failure-to-alarm rate. This sensor, while in one of the best locations for exposure to plume gases, did not show significant enough differences between normal and pre-ignition CO levels to make it a **good** candidate for a detection system.

Figure 29 shows the results for the site 10 total-cooking-gas sensor. Since the gas burner of focus was located on the opposite side of the range from the primary electric burner, data from the site 8 sensor replaced the **site** 10 data for the gas-range tests. For an alarm threshold of 4.8 V, the sensor generated a 19% false-alarm rate and a 7% failure-to-alarm rate.

Some false alarms occurred for cases that may be characterized as special which has an **impact** on the performance characterization of each sensor. The tests have been separated into categories reflecting these **special** cases in Table 7. Table 7 is a chart which lists the sensors discussed in this section and the **section** on thermocouples, their associated figures, their assigned alarm thresholds, and their false-alarm and failure-to-alarm rates based on the thresholds. The following paragraphs discuss the information in Table 7 and its interpretation.

The thresholds in Table 7 were selected with an effort to minimize both false alarms and failures to alarm, but the chosen values are not the only valid settings nor are they necessarily the best. For the alarm **columns** in Table 7, the numbers in parentheses are the percentages reflected by the test numbers that are listed. The percentages were calculated by dividing the number of incidents of false alarm or alarm failure (failure to alarm) by the total numbers of opportunities for each. These totals are 32 for false alarms and 30 for failures to alarm and reflect the number of tests or portions of tests that were normal and unattended, respectively.

The special cooking-case columns in Table 7 are steak, fish, cleaning, and other. The blackened-fish case is an inherently attended cooking procedure for which a temporary deactivation (with automatic reactivation) of the detection system by the operator could prevent disruption of **cooking** by range **shutdown**. Another solution to special attended cooking cases could be motion detector technology which could confirm that a process is indeed attended. Broiling of steak and the self-cleaning oven cases are operations that don't utilize the range surface and are also not a threat for ignition. Inclusion of an input to the detection system algorithm indicating that the **oven** is in use for broiling or self-cleaning could prevent these activities from being disrupted. In the "other" category, cases 5, 10, and 19 appear for some sensors. Case 10 is stir-fry vegetables which is another inherently attended cooking procedure which could be protected from disruption as **described** previously. Cases 5 and 19 are multiple pans of boiling water. The reason that these normal cases generated higher readings was that oil residue from previous tests was not completely removed from the burners and produced some smoke for several minutes in the early heating period. If this occurred in a real kitchen, the prevention of the production of smoke could be considered a positive situation, and the shutdown of the range would alert the operator that debris should be cleaned **from** a burner.

Additional columns in Table 7 are for "real" false alarms, and "real" and "other" failures to **alarm**. The tests listed under the "real" columns could not be accounted for in the ways that oven broiling and cleaning and attended cooking could be. Therefore the "real" tests represent deficiencies in the ability of particular sensors to differentiate between normal and pre-ignition conditions. The "other" instances are considered in the discussion of specific sensor results. Based on the preceding explanations of the table, the gas sensors already discussed did not

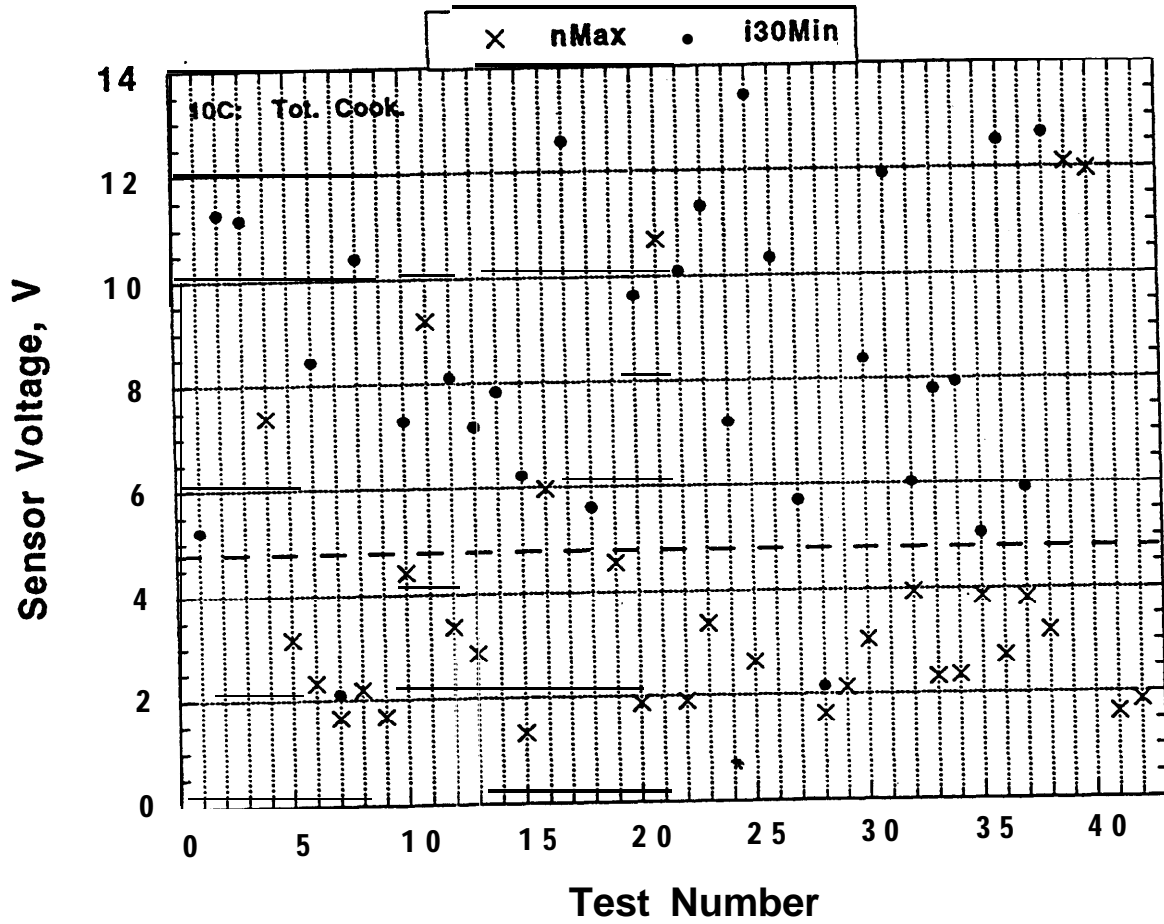

Figure 29. Site 10 total-cooking-gas sensor maximum normal and minimum ignition output 30 s before ignition **versus** test number. Data for the gas-range tests (35-38) are from the site 8 **total-cooking-gas** sensor.

Table 7. Selected sensors' false-alarm and alarm-failure performance for 42 tests

Fig. No.	Sensor	Thresh-hold	Tests with False Alarms					Tests with Alarm Failures	
			Real (%)	Steak (%)	Fish (%)	Cleaning (%)	Other (%)	Real (%)	Other (%)
28	9D Carbon Monoxide	0.32 V	35,37 (6)		11,21 (6)	39,40 (6)	5,19 (6)	1,7,18,24,27,32 (20)	
29	10C Total Cooking	4.8 V		4,16 (6)	11,21 (6)	39,40 (6)		7,28 (7)	
30	7A General Alcohol	3.5 V	35,37 (6)	4,9,16,29 (13)	11,21 (6)		10,19 (6)		
31	7B Cooking Alcohol	3.3 V	35,37 (6)	4,9,16,29 (13)	11,21 (6)		10,19 (6)		
32	9A General Hydrocarbon	2.5 V	34 (3)	16 (3)	11,21 (6)	39,40 (6)		7,35 <sup>s</sup> (7)	
33	9A General Alcohol	3.1 V		4,16 (6)	11,21 (6)	39,40 (6)		7,35 <sup>s</sup> (7)	
34	9B Total Cooking	2.7 V		4 (3)	11,21 (6)	39,40 (6)		7,35 <sup>s</sup> (7)	1 (3)
35	9B Cooking Alcohol	3.5 V			11,21 (6)	39,40 (6)	19 (3)		
36	11A General Hydrocarbon	1.7 V		4 (3)	11,21 (6)	39,40 (6)		7,35 <sup>s</sup> (7)	

Fig. No.	Sensor	Thresh- hold	Tests with False Alarms					Tests with Alarm Failures		
			Real (%)	Steak (%)	Fish (%)	Cleaning (%)	Other (%)	Real (%)	Other (%)	
37	11A General Alcohol	3.0 V		4 (3)	11,21 (6)	39,40 (6)		7,35 <sup>s</sup> (7)		
38	11B Total Cooking	2.2 V		4,16 (6)	11,21 (6)	39,40 (6)		7,35 <sup>s</sup> (7)		
39	11B Cooking Alcohol	3.5 V		4 (3)	11,21 (6)	39,40 (6)		7,35 <sup>s</sup> (7)		
40	T19	50 °C	5,7,12,13,19,28, 30,32,35,37 (31)	4,9,16, 29 (13)	11 (3)	39,40 (6)		17 (3)		
41	Tpan (30 s)	340 °C	12 (3)		11,21 (6)		19 (3)			
42	Tpan (60 s)	340 °C	12 (3)		11,21 (6)		19 (3)	23 (3)		
43	Tpan X 7A Gen. Alc.	1500 V°C	*		11,21 (6)		19 (3)			
44	Tpan X 7B Cook. Alc.	1500 V°C			11,21 (6)		19 (3) <sup>s</sup>			
45	Tpan X 9B Cook.Alc.(30 s)	1400 V°C			11,21 (6)		19 (3)			
46	Tpan X 9B Cook.Alc.(60 s)	1400 V°C			11,21 (6)		19 (3)			

<sup>s</sup> Test 35 did not proceed to ignition and therefore did not produce a true failure to alarm.

perform as poorly as first stated. The site 9 CO sensor generated 6% false-alarm and 20% failure-to-alarm rates. The site 10 total-cooking-gas sensor generated 0% and 7% rates, respectively.

The responses for the best **gas** sensors at sites 7, 9, and 11, which were the three **major** sites on the range's plane of symmetry, are presented in the following figures. These sensors showed significant differentiation between normal and pre-fire conditions. None of the gas sensors produced complete separation of the conditions **sufficient** to allow its use as a single detector that would have both acceptable false-alarm and failure-to-alarm rates unless the special cases were considered in the detection scheme. The site **9B** cooking-alcohol sensor was most effective, and with the use of modifications to the detection system to account for special attended cooking cases would perform **perfectly**.

Figures 30 and 31 are for gas sensors at site 7. Figure 30 shows the site 7 general-alcohol sensor's normal maxima and ignition minima for each test. An alarm threshold set at 3.5 V would not produce any failures to alarm, but 12 instances of false alarms would have occurred in the 42 tests. Some of the false alarms are special cases as have been noted. The sensors would have alarmed for all of the broiled-steak tests, the self-cleaning-oven tests, the **blackened-catfish** tests, and some of the stir-fried-vegetable and multiple-water tests. The remaining tests that would produce false alarms **are** 35 and 37 which are both water-and-oil tests heated on the gas range. No failures to alarm would be generated by this sensor. Figure 31 shows the compiled test results for the site '7 cooking-alcohol sensor. With a threshold set at 3.3 V, the identical set of false alarms would occur as for the site 7 general-alcohol sensor with the same reasoning.

Figures 32 through 35 are for site 9 gas sensors. Figure 32 shows the general hydrocarbon-gas sensor's responses. For a threshold set at 2.5 V, two water-and-oil tests, 7 and 35, would result in failure to alarm. Test 35, however, did not proceed to ignition, and the data point results from the time when heating was stopped so only one failure to alarm is authentic. Catfish tests 11 and 21, steak test 16, self-cleaning tests 39 and 40, and normal-to-unattended chicken test 34 would all produce false alarms. Figure 33 shows the plot for the general-alcohol sensor at site 9. With a threshold of 3.1 V, this sensor would perform very similarly as the site 9 general-hydrocarbon sensor. The differences would be a false alarm for steak test 4 and no false alarm for chicken test 34. Figure 34 shows **the plot** for the site 9 total-cooking-gas sensor. With a threshold of 2.7 V, it **would** perform just as the site 9 general-alcohol sensor except steak test 16 would not produce a false alarm. Figure 35 shows the responses of the cooking-alcohol sensor at site 9. This sensor would produce no **failures-to-alarm** with an alarm threshold of 3.5 V. The only false alarms would occur for catfish tests 11 and 21, self-cleaning oven tests 39 and 40, and water test 19 with the smoking oil on the rear burner. This gas sensor had the best performance of the site 7 **and** 9 sensors discussed thus far.

Figures 36 through 39 show the results for the site 11 gas sensors. For the **general-hydrocarbon** sensor results shown in Figure 36, many of the ignition voltages are much lower than for previous sensors and are close to the main body of normal-cooking maxima. A threshold of 1.7 V would produce the same set of faults as the total-cooking-gas sensor at site 9. Figure 37 shows that a threshold of 3 V would produce the same results for the general-alcohol sensor as the site 11 general-hydrocarbon sensor. Other threshold values could be chosen which would

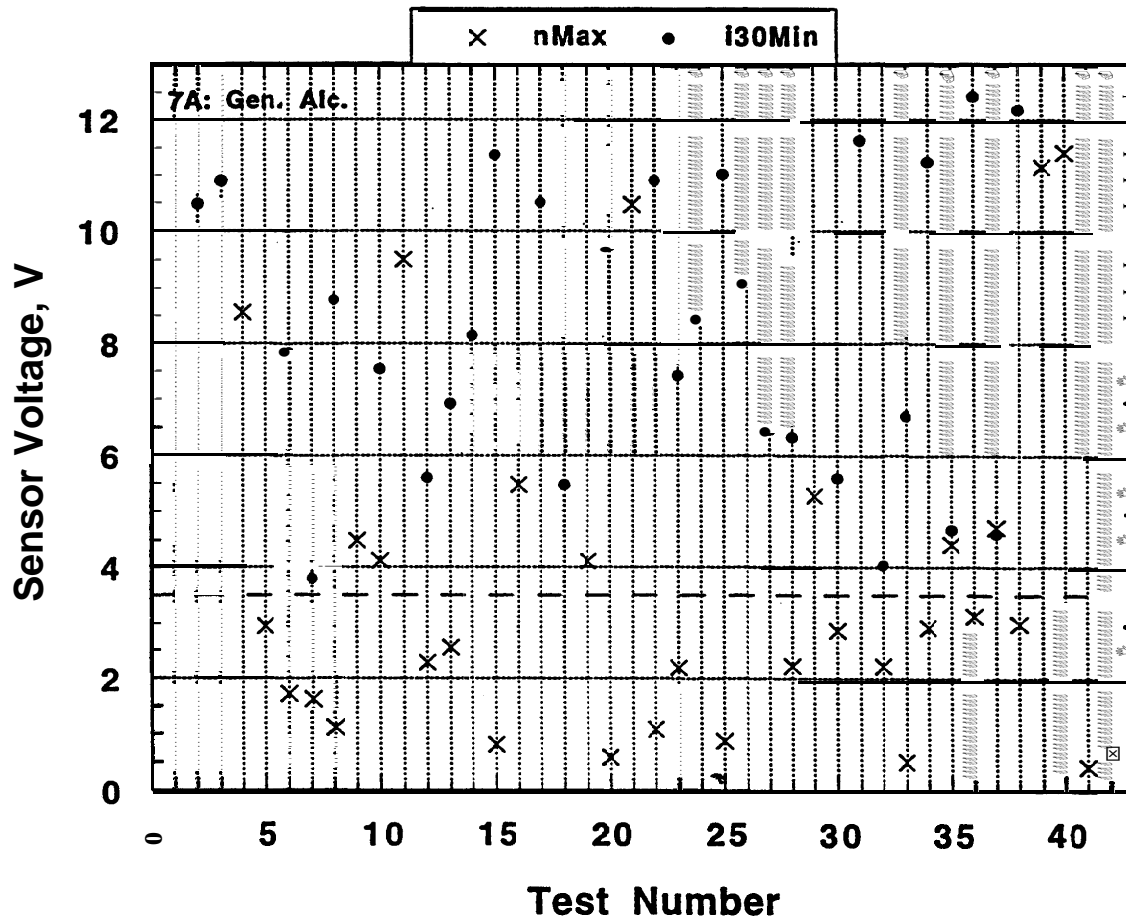

Figure 30. Site 7 general-alcohol sensor maximum normal and minimum ignition output 30 s before ignition versus test number.

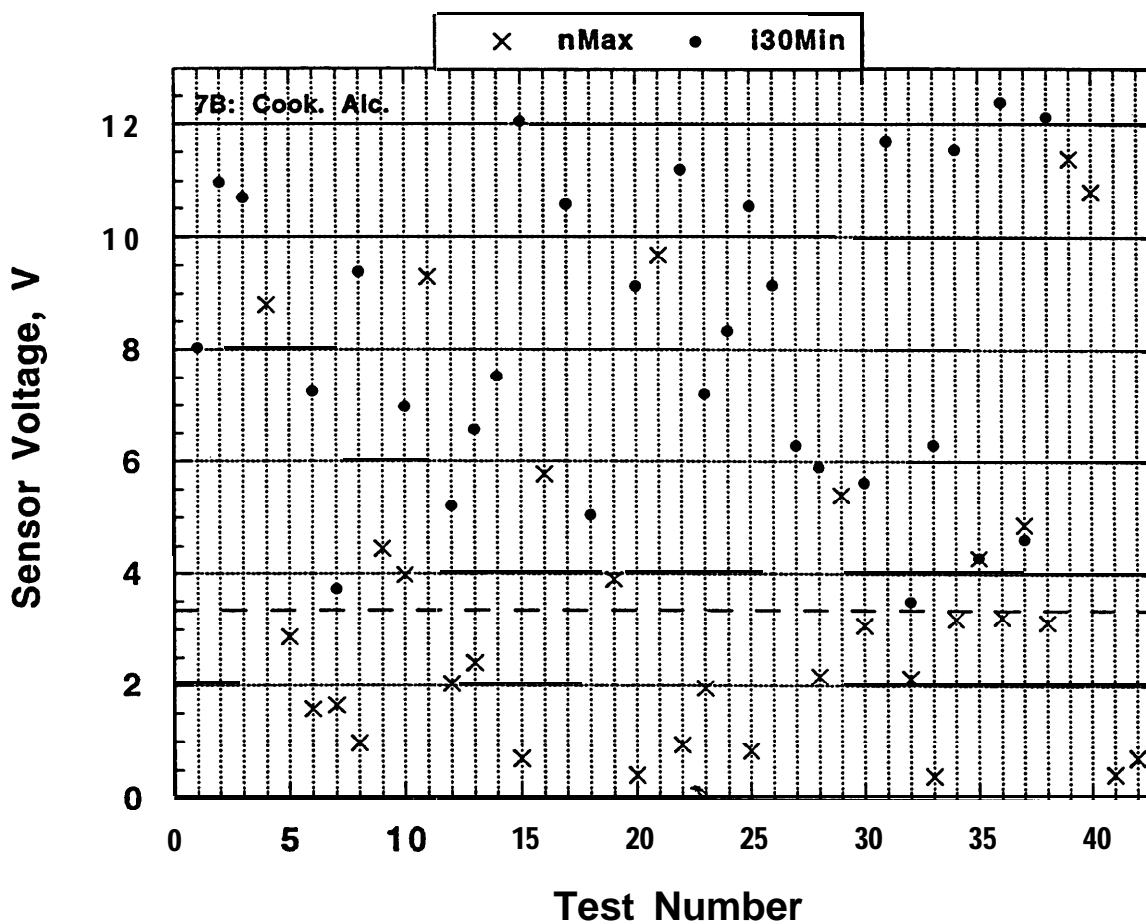

Figure 31. Site 7 cooking-alcohol sensor maximum normal and minimum ignition output 30 s before ignition **versus** test number.

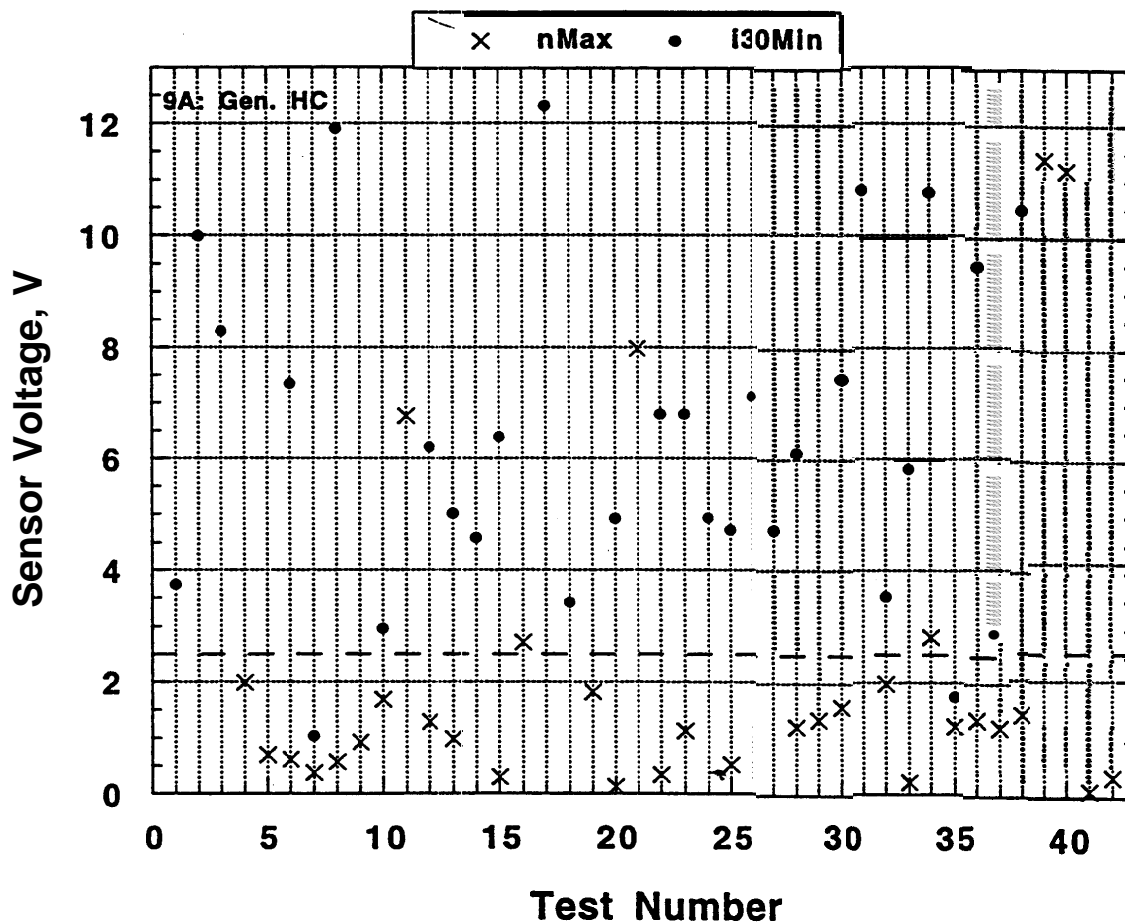

Figure 32. Site 9 general-hydrocarbon sensor maximum normal and minimum ignition output 30 s before ignition versus test number.



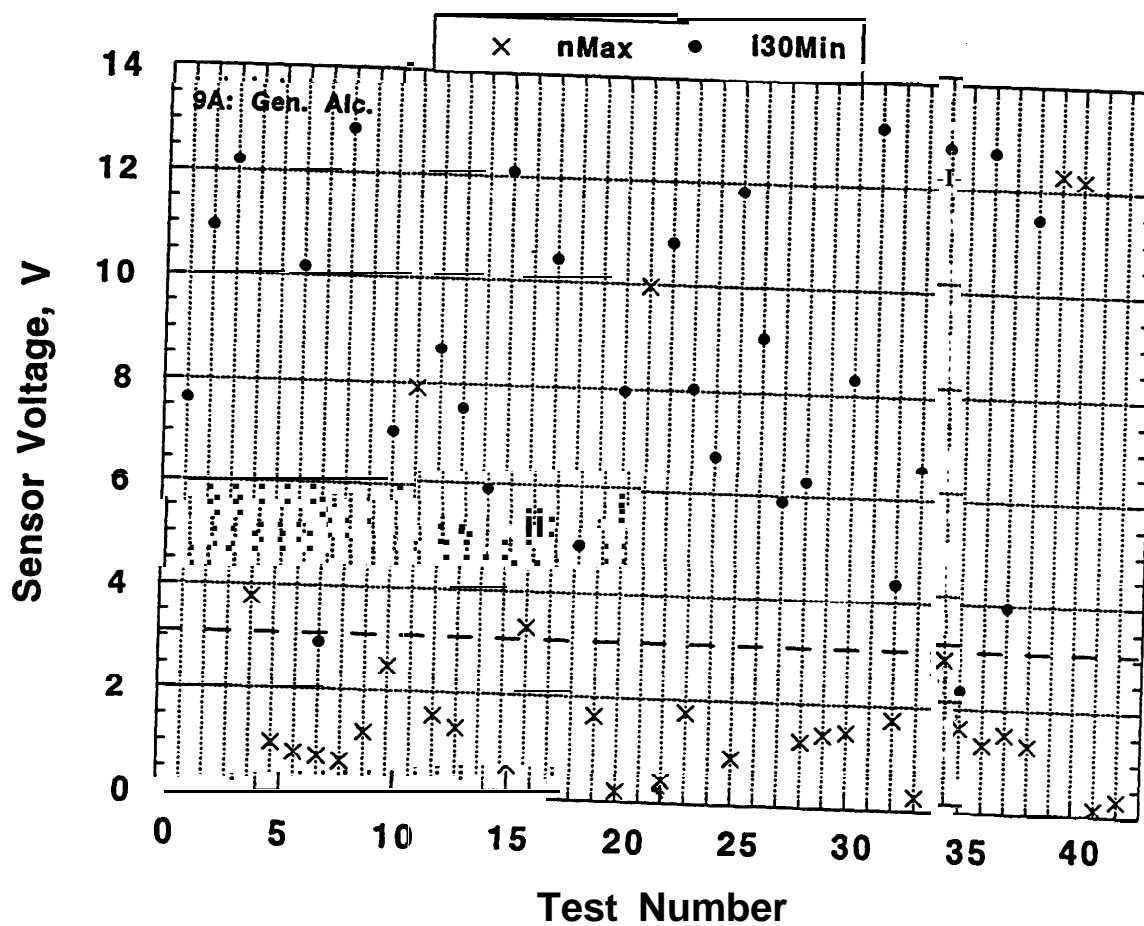

Figure 33. Site 9 general-alcohol sensor maximum **normal** and minimum ignition output 30 s before ignition **versus** test number.

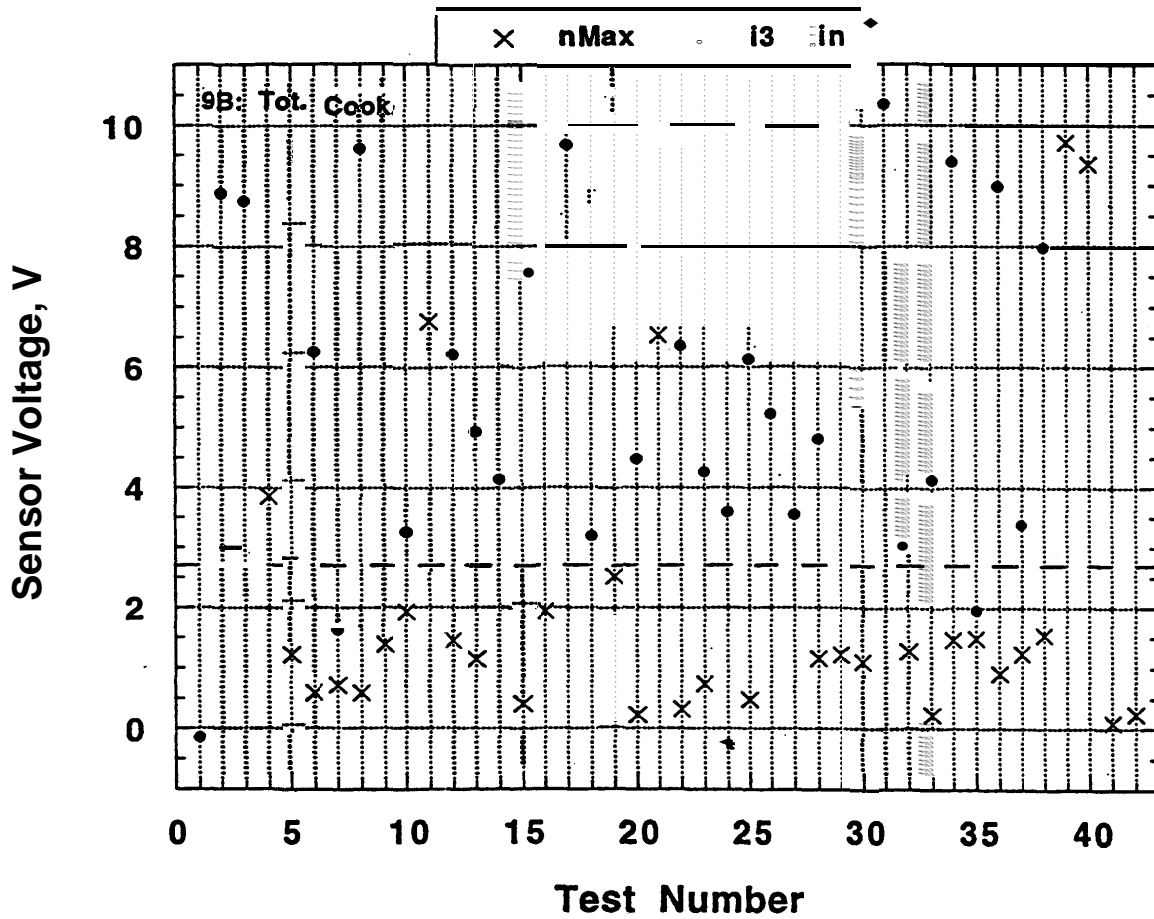

Figure 34. Site 9 total-cooking-gas sensor maximum normal and minimum ignition output 30 s before ignition versus test number.

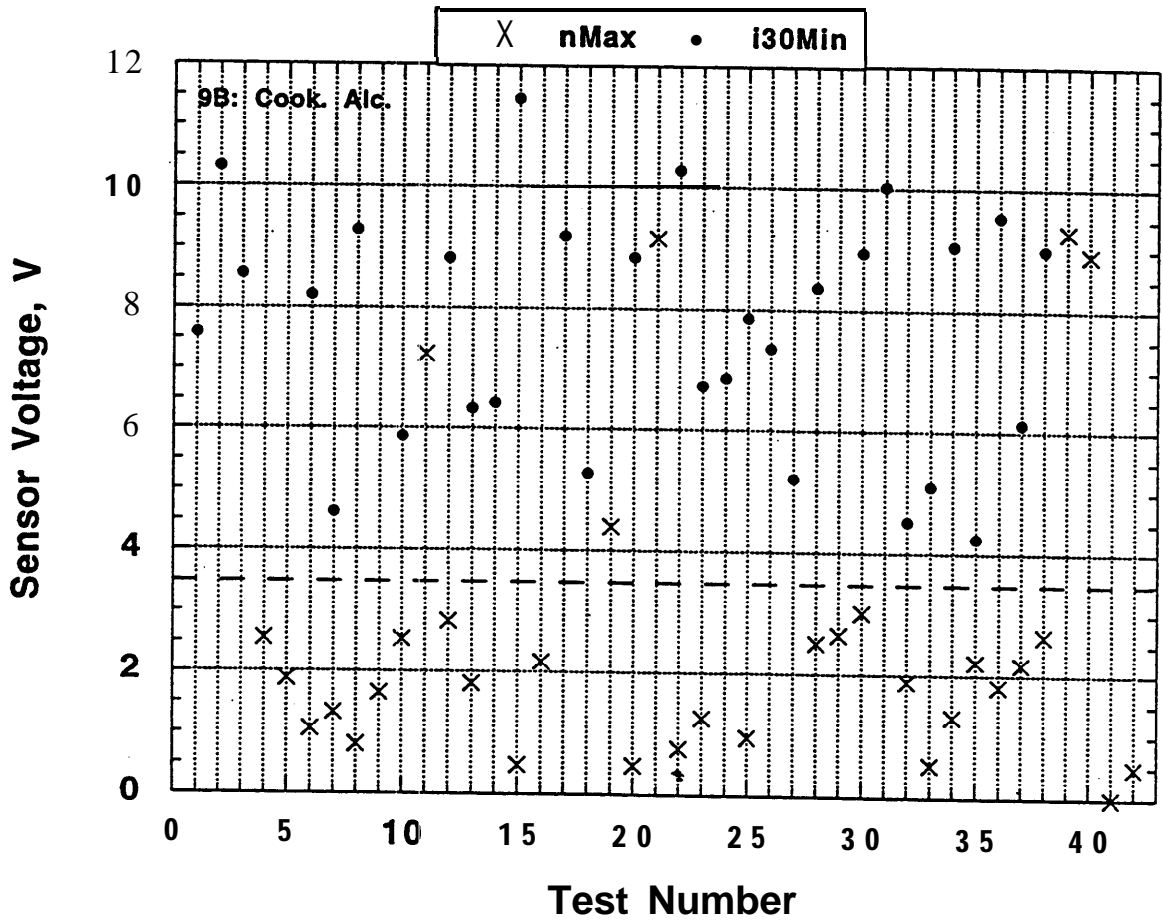

Figure 35. Site 9 cooking-alcohol sensor maximum normal and minimum ignition output 30 s before ignition versus test number.