

LANDSAT D DATA FORMAT CONTROL BOOK

VOLUME V
(PAYLOAD)

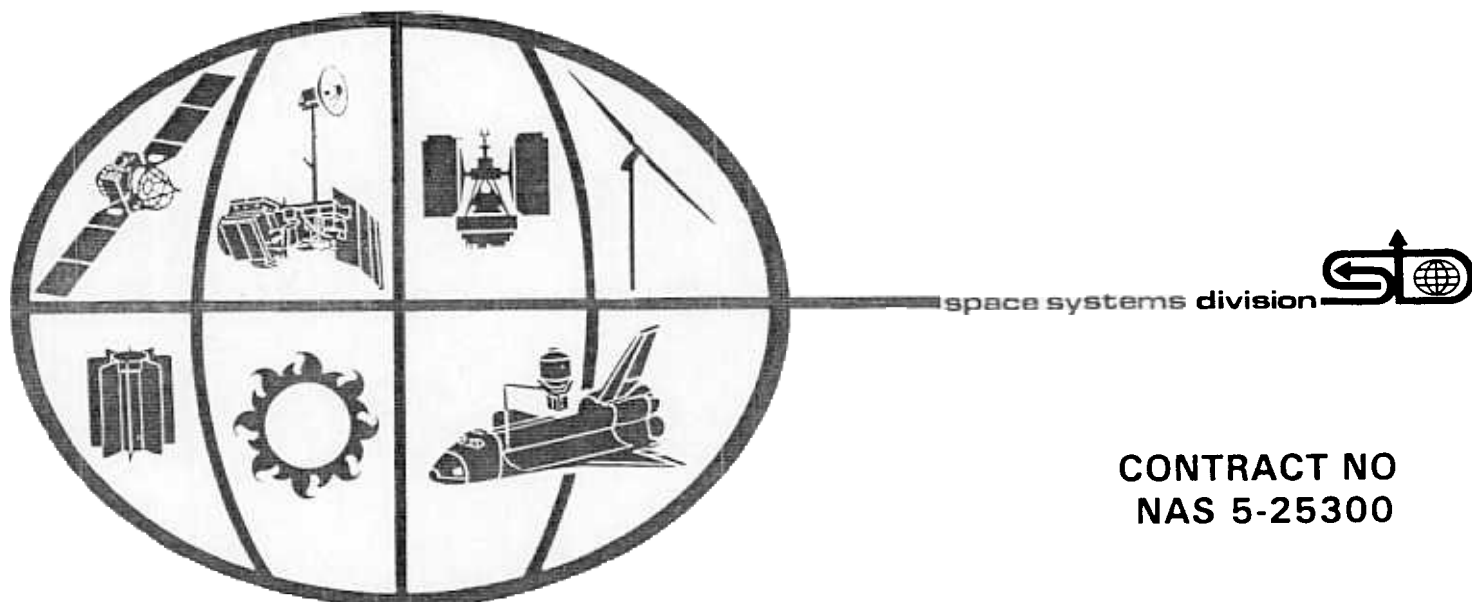

space systems division



CONTRACT NO
NAS 5-25300

Date: 12/15/81

DFCB DISTRIBUTION

SVS-10126A - AN-1 12/15/81

*T. AEPLI	M7235	D. ABBOTT	GSFC, BLDG. 28	NASA	
*H. ANDREW	U7035	T. ASLAM	GSFC, BLDG. 28	CONTRACT	CODE 435,
E. BEYER	M7235	*J. AVERY	GSFC, BLDG. 28	* OFFICER	GSFC (15)
E. BUERGER	M7235	*J. BROOKS	GSFC, BLDG. 28		
*R. CLAYTON	M7235	J. BROWN	GSFC, BLDG. 28		
*G. EHRGOTT	M7222	A. CHERICO	GSFC, BLDG. 28		
W. FRANKLIN	M7222	A. COFFIN	GSFC, BLDG. 28		
*P. GIUSTINO	M7034	R. CROUSE	GSFC, BLDG. 28		
*H. GUNTHER	M7024	E. DAY	GSFC, BLDG. 28		
*A. KITTO	U7035	*J. DIETZ	GSFC, BLDG. 28		
*N. KOEPP-BAKER	M7222	J. EFNER	GSFC, BLDG. 28		
*D. KORENSTEIN	M7235	*R. GRUBIC	GSFC, BLDG. 28		
*P. MALHERBE	M7222	R. HICKS	GSFC, BLDG. 28		
M. LAMNIN	M7222	*T. HORN	GSFC, BLDG. 28		
R. QUINN	M4618	T. KELLER	GSFC, BLDG. 28		
*J. REGER	M7235	F. KRAUS	GSFC, BLDG. 28		
J. SCHUMACHER	M7222	L. KUYKENDALL	GSFC, BLDG. 28		
J. SEITNER	M7222	*J. MARTAK	GSFC, BLDG. 28		
S. SIEGEL	M7222	*R. RHODES	GSFC, BLDG. 28		
R. STAUFFER	M7222	H. RICE	GSFC, BLDG. 28		
*R. TALIPSKY	U7035	D. SMITH	GSFC, BLDG. 28		
W. WOLFE	M7235	*J. SPEER	GSFC, BLDG. 28		
<u>LANDSAT LIBRARY</u>	M7047	*R. SPENCER	GSFC, BLDG. 28		
		H. STUVEN	GSFC, BLDG. 28		
		D. SUNG	GSFC, BLDG. 28		
		R. WATTIS	GSFC, BLDG. 28		
		*B. WARREN	GSFC, BLDG. 28		
		R. WILTAMUTH	GSFC, BLDG. 28		
		*T. WINCHESTER	GSFC, BLDG. 28		
		*D. WISE	GSFC, BLDG. 28		
		L. WOOLLEY	GSFC, BLDG. 28		
		<u>LANDSAT LIBRARY</u>	GSFC, BLDG. 28		

* Indicates copy of document required.
 Remainder to receive distribution list only

SVS-10126
Volume V
31 July 1981

LANDSAT D
DATA FORMAT CONTROL BOOK
VOLUME V (PAYLOAD)

Prepared for
GODDARD SPACE FLIGHT CENTER
Greenbelt, Maryland 20771

Under
Contract No. NAS 5-25300

by

GENERAL ELECTRIC SPACE DIVISION
Valley Forge Space Center
P.O. Box 8555
Philadelphia, Pennsylvania 19101

LSD-WPC-012

LANDSAT-D
DATA FORMAT CONTROL BOOK
VOLUME V (PAYLOAD)

PREPARED BY: *H. Andrew* DATE: 7/28/81
H. Andrew, Systems Engineer

APPROVED BY: *T. Aepli* DATE: 7/29/81
T. Aepli, Manager
Landsat-D Systems Engineering

APPROVED BY: *S. Capodici* DATE: 7-29-81
S. Capodici
Landsat-D Program Manager

ISSUED BY: *Donna Johnston* DATE: 7/31/81
Print Control & Reproduction

REVISION LOG

This log identifies those portions of this specification which have been revised since original issue. Revised portions of each page, for the current revision only, are identified by marginal striping.

Revision	Paragraph Number(s) Affected	Rev. Date

TABLE OF CONTENTS

SECTION

1	Introduction	1-1
1.1	Overview of Payload Data Systems	1-1
1.2	Payload Data Systems and Data Flow Description	1-1
1.2.1	Flight Segment	1-1
1.2.1.1	Thematic Mapper	1-5
1.2.1.2	Multispectral Scanner System	1-15
1.2.1.3	MSS Multiplexer	1-23
1.2.1.4	Wideband Communications Subsystem	1-27
1.2.2	Ground Segment	1-29
1.2.2.1	Data Management System (DMS)	1-29
1.2.2.2	Control and Simulation Facility (CSF)	1-30
2	Thematic Mapper Data Formats	2-1
2.1	General	2-1
2.2	TM Format	2-1
2.2.1	Major Frame Sync Code	2-2
2.2.2	Minor Frame Format	2-2
2.2.3	Time Code Format	2-6
2.2.4	Mid Scan Code Format	2-8
2.2.5	End Scan Code Format	2-8
2.2.6	Line Length Data	2-10
2.2.7	Post Amble Data	2-12
2.2.8	Encoding	2-12
3	Multispectral Scanner Data Formats	3-1
3.1	General Information	3-1
3.2	MSS Major Frame Format	3-1
3.2.1	Preamble	3-4
3.2.2	Line Start Code	3-4
3.2.3	Minor Frame	3-7
3.2.4	Time Code	3-7
3.2.5	Scene Data	3-8
3.2.6	Mid Scan Code	3-8
3.2.7	End Scan Code	3-10
3.2.8	Calibration or DC Restore	3-10
4	Acronyms and Abbreviations	
5	References and Sources	

LIST OF FIGURES

FIGURE	TITLE	PAGE
1-1	Landsat-D Payload Data System Flow	1-2
1-2	Payload Data	1-3
1-3	Thematic Mapper - General Configuration	1-7
1-4	Thematic Mapper Optical System	1-10
1-5	Thematic Mapper Functional Block Diagram	1-11
1-6	MSS Overview	1-17
1-7	Ground Scan Pattern for a Single MSS Detector	1-18
1-8	Scanner Functional Block Diagram	1-21
1-9	Typical Calibration Wedge Curve	1-22
1-10	MSS Multiplexer Functional Block Diagram	1-24
1-11	Wideband Communications Subsystem	1-28
1-12	CSF "Quick-Look" Hardware Block Diagram	1-32
2-1	TM PN Code	2-4
2-2	TM Minor Frame Format	2-5
2-3	TM Time Code Format	2-7
2-4	TM End Scan Code Format	2-9
2-5	TM Line Length/Scan Direction Code	2-11
3-1	MSS Major Frame Format	3-3
3-2	MSS Minor Frame Format	3-6
3-3	MSS Time Code Format	3-9
3-4	MSS Mid/End Scan Code Format	3-11

LIST OF TABLES

TABLE	TITLE	PAGE
1-1	MSS Modes	1-15

SECTION 1
INTRODUCTION

OVERVIEW OF PAYLOAD DATA SYSTEMS

LANDSAT-D flight segment payload is the Thematic Mapper and the Multispectral Scanner. This section of the Data Format Control Book defines the payload data formats.

PAYLOAD DATA SYSTEMS AND DATA FLOW DESCRIPTION

following paragraphs provide narrative and visual descriptions of the Landsat-D payload data handling hardware and data flow paths. Figure 1-1 shows the pictorial top-level TM and MSS data flow and Figure 1-2 shows the detailed subsystem level block diagrams of the flight and ground segments, respectively.

1.2.1 FLIGHT SEGMENT

The flight segment section describes the key subsystems and shows payload data from the Landsat sensing instruments through to the GSFC Landsat-D Data Management System. Figure 1-2 shows an overview of the payload data flow.

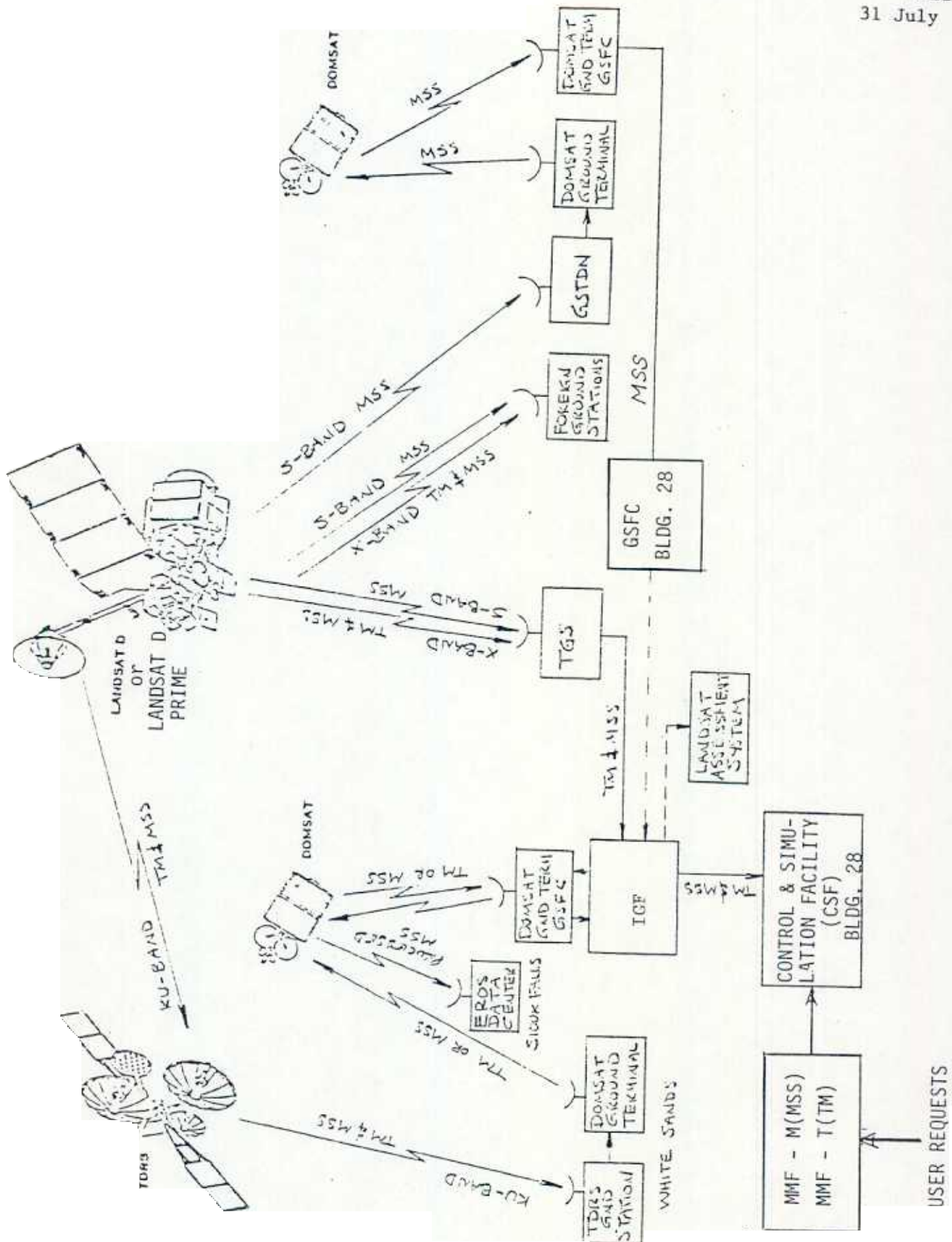

Note: Broken lines indicate hand carry tape data.

Figure 1-1. Landsat-D Payload Data System and Flow

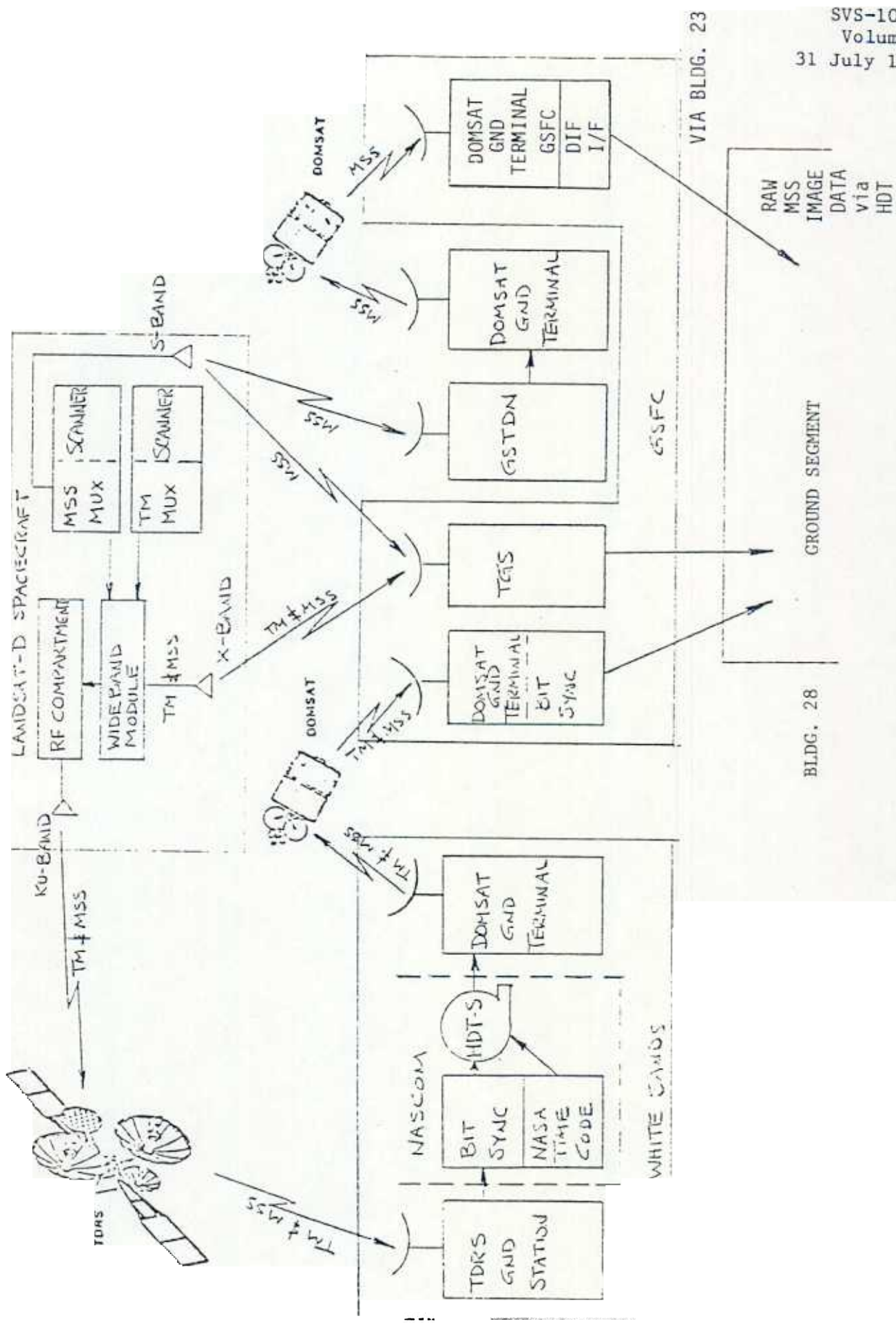

Figure 1-2. Payload Data Transmission

On board the Landsat spacecraft, TM data are output to the wideband communications system. From this point, the X-band data link can transmit data directly to foreign ground stations or to the GSFC Transportable Ground System. The TM data can also be routed to the RF compartment and transmitted over the high-gain Ku-band antenna to a TDRS satellite.

The Ku-band data is relayed by the TDRS S/C to the TDRS ground station at White Sands. The TDRS Ground Segment records the TM data for subsequent transmission over the DOMSAT link. The TM serial data stream is recorded on the 42-track wideband tape recorder with the NASA 36-bit time code generalized locally and recorded on one of the 42 tracks. The serial data tape track assignment is the same as the HDT-R tape with exception of the NASA time code. (The time format is explained in DFCB Vol. IV, Products.)

The tape, referred to as the HDT-S tape, is transferred to the White Sands DOMSAT ground terminal, where, within a few hours, it is played back at one-half (1/2) speed over the DOMSAT link to the DOMSAT ground terminal at GSFC Bldg. 23. DOMSAT GSFC records the data on the HDT-R tapes which are subsequently transferred to the Ground Segment GSFC Bldg. 28.

The GSFC TGS can receive TM data directly from the Flight Segment. The TGS transfers the data to the Data Receive Record and Transmit System (DRRTS).

The Multispectral Scanner data can be transmitted over the Ku-band and follow the same path as the TM data. However, the White Sands Domsat Ground Station can playback an MSS tape at either two or three times the speed at which

it was recorded by the White Sands TDRS Ground Station. Alternately, the data can be transmitted bent pipe between the White Sands TDRS and the White Sands Domsat ground stations. This provides a direct transmission link (no tape recording) from the TDRS satellite to the GSFC Domsat Ground Terminal.

MSS data can be transmitted from the MSS MUX over an S-band link directly to the foreign ground stations or to the GSFC Transportable Ground Station. The MSS S-band can be linked to the Ground Spacecraft Tracking Data Network (GSTDN) ground stations at Goldstone California or at Fairbanks, Alaska. The GSTDN stations record the MSS data on tape for subsequent transmission over the Domsat link to the Domsat Ground Terminal at GSFC Building 23. The GSFC Domsat Ground Terminal records the MSS data on HDT-R tapes and transfers the tapes to the Landsat Data Management System. Figure 1-2 shows the MSS data transmission paths.

1.2.1.1 Thematic Mapper

The Thematic Mapper is intended for multispectral sensing from low polar orbits. Figure 1-3 shows the General Configuration of the Thematic Mapper subsystem. The instrument mounts in the spacecraft in a roughly horizontal position with the sun shade pointing toward earth. A scan mirror is located directly above sun shade aperture, surrounded by its drive mechanisms, control electronics and scan monitor hardware. The mirror itself is a very lightweight design constructed of beryllium with an eggcrate internal structure for maximum stiffness and minimum inertia. The main structure is aluminum honeycomb with the telescope optics rigidly mounted to it through a graphite-epoxy support structure.

The primary mirror mounts about halfway down the length of the instrument, preceded by optical baffling and the secondary mirror. The secondary mirror is supported by struts to the telescope support structure. Directly behind the primary mirror are located the scan line corrector, the internal calibrator, and the visible focal plane, along with mounting hardware and alignment mechanisms. The internal calibrator uses an incandescent lamp feeding through a fiber optics bundle as a source for bands 1 through 5 and 7. It uses a commandable-temperature blackbody for band 6. The scan line corrector is a small, motor driven, two mirror system which rotates at a rate equal and opposite to the angular velocity of the spacecraft in the orbital track direction.

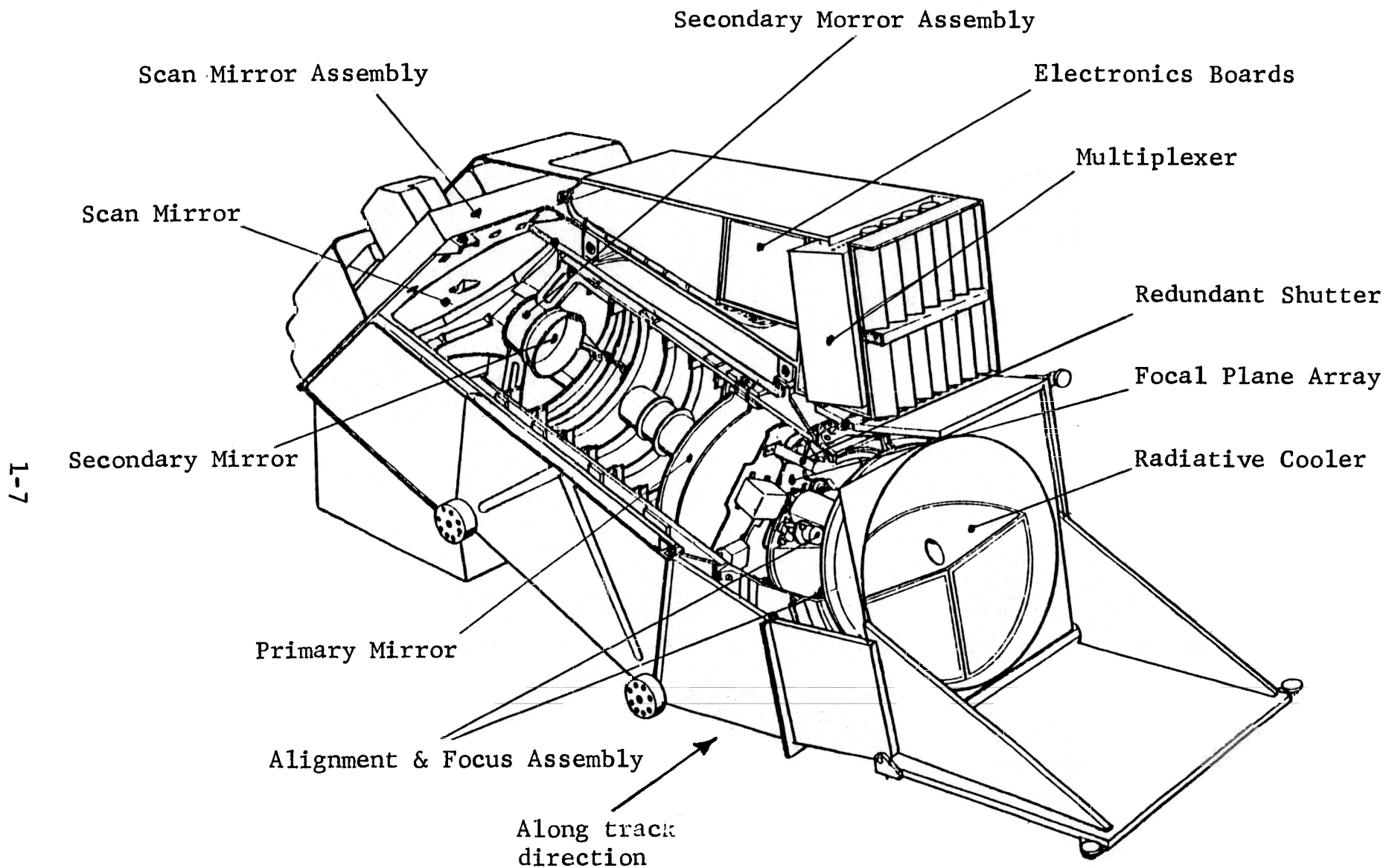

Figure 1 - 3 Thematic Mapper General Configuration

The radiative cooler, relay optics, and infrared detector arrays are located on the aft end of the instrument. The cooler has a protective door and outgassing heaters.

Electronic equipment is packaged in a wedge-shaped box above the telescope. It contains the multiplexer and signal amplifiers and filters for all channels. Most of the power dissipated in the instrument occurs in this box. Thermal louvers radiate the heat into space. A bimetallic strip automatically controls the louvers to maintain the proper operating temperature.

Figure 1-4 illustrates the optical design approach. A principal feature of the design is the use of an object plane scan mirror, which simplifies the performance requirements for the rest of the optical system by requiring the telescope to operate only at very small field angles. Further, the same zone of each element is used at all scan angles. Many of the major optical problems of off-axis images are eliminated, i.e., pupil size, image distortion, coma and astigmatism.

The telescope is an f/6 design, chosen to provide a reasonable size image at the focal plane. The image quality requirements are easily met by the Ritchey-Chretien design.

The scan line corrector shifts the optical line of sight by the width of the detector array at the end of each scan. The scan line corrector employs two small mirrors, parallel to each other, but rotating on a common axis to displace the optical axis.

Relay optics, of reflective design, transfer the energy to the cooled focal plane. The two relay elements and the concentric design were selected for simplicity and ease of assembly and alignment. The folded configuration was chosen as a convenient way to obtain an optical axis parallel to the axis of the radioactive cooler. The image quality of the relay is excellent over the required field, allowing for addition of a third cooled spectral band, band 7. The object plane scanning concept provides freedom from scan modulation for the infrared detectors.

The spectral bands are controlled by bandpass filters. The filters are positioned close to the detector elements to reduce the effects of optical crosstalk. In bands 5, 6 and 7 the filters are kept cool in order to reduce background radiation from the filter itself.

The internal calibration employs three lamps, various optical filters, and fiber optics to produce seven radiance levels within the dynamic range of each of bands 1 to 5 and 7; a commandable blackbody is used to obtain three temperature levels in band 6. A feedback control loop incorporating a silicon photodiode is used to maintain a constant radiance output during lamp operation over the life of the Thematic Mapper.

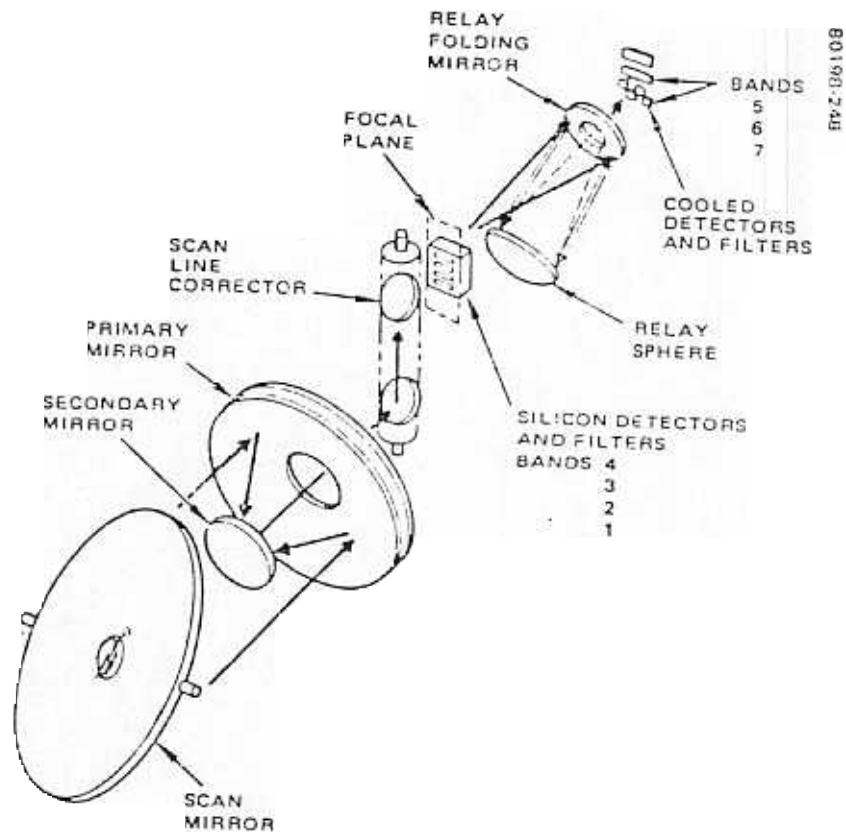

Figure 1-4. Thematic Mapper Optical System

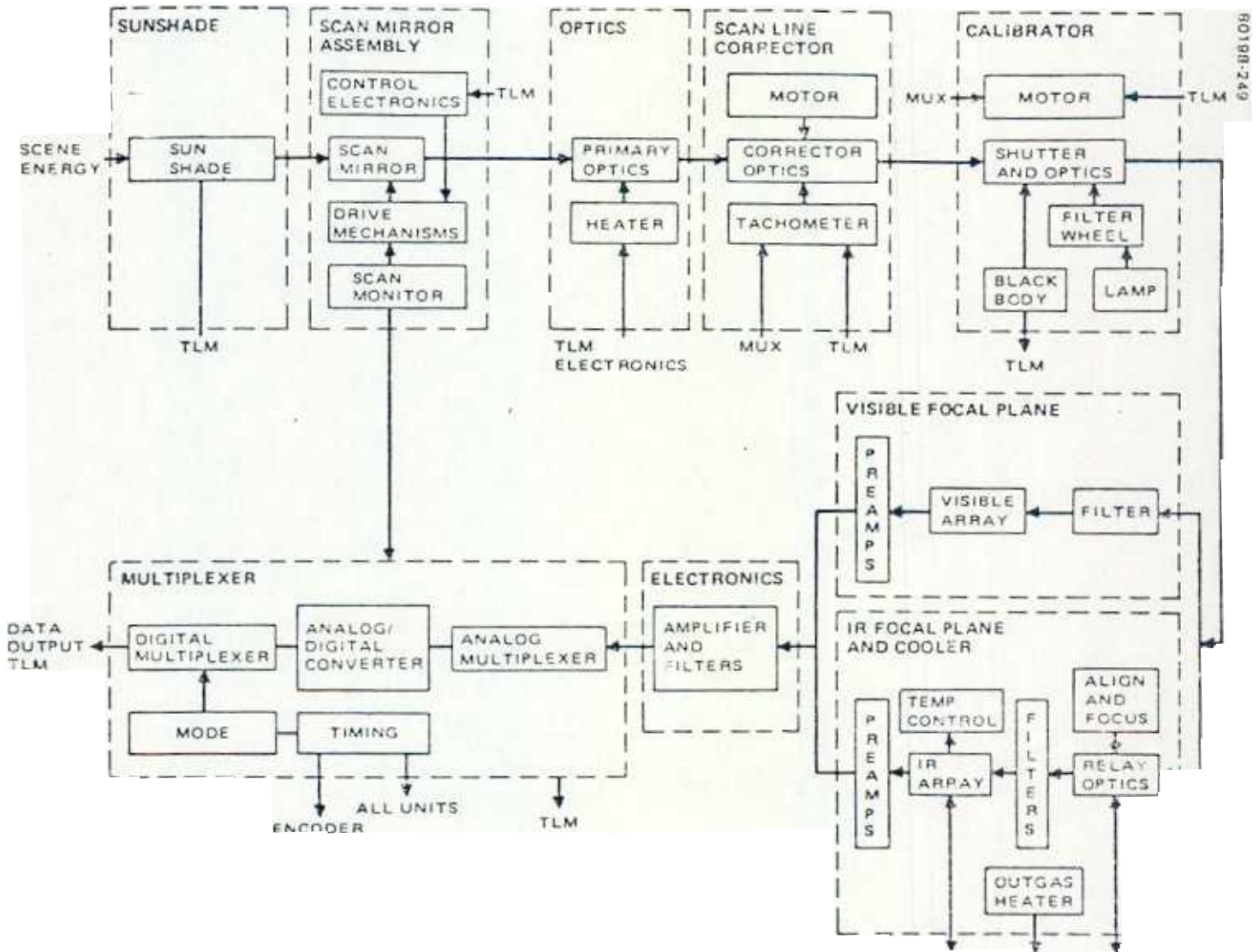

Figure 1-5. Thematic Mapper Functional Block Diagram

The Thematic Mapper functions as illustrated in the abbreviated block diagram of Figure 1-5. Radiant energy enters the instrument through the sun shade. calibrator allows external calibration of the visible bands once per orbit. Scanning of the field of view is done by the scan mirror in the cross track direction and by the motion of the spacecraft in the along-track direction. scan mirror is a 21 x 16 inch ellipse which presents equal area at all scan angles. It provides a linear scan motion covering a swath on the ground of km. A precision digital controller drives the mirror. A scan line corrector located behind the primary optics compensates for the forward motion of the spacecraft and allows the scan mirror to produce usable data in both scan directions

The telescope is of the Ritchey-Chretien type with 16 inch primary optics. It contains a internal calibration system for both the visible and thermal bands. It has a ground-commandable focus adjustment and a registration alignment mechanism for the infrared bands. The detector package for the visible bands consists of four linear arrays of 16 silicon detectors, each located at the focal plane along with their preamplifiers

The energy for the infrared bands passes through relay optics to the infrared array mounted on the radiative cooler. The cooled array consists of two 16-element linear arrays of indium-antimonide cells and a 4-element array of mercury-cadium-telluride cells. The radiative cooler is a two-stage unit with ground-selectable closed loop temperature control.

signals from the detectors are amplified, filtered and sent to the multiplexer. The multiplexer accepts 100 channels of signal data, analog multiplexes all detector channels in each band on a single channel, converts to digital, and then multiplexes the digital channels along with telemetry data from the spacecraft on a single 84.9 Mbps digital output stream.

System timing is provided by the multiplexer based on signals received from the scan monitor in the scan mirror assembly. Optical pulses are generated by the scan monitor at the start, middle and end of each scan line. These signals are in the multiplexer along with a crystal oscillator to provide timing signals for synchronization of the scan line corrector, calibration shutters, filter shutter and dc restore circuits. In this manner all appropriate functions remain in synchronization and all images retain geometric fidelity even in the presence of slight phase shifts in the scan mirror.

In addition to encoding and formatting of sensor information, the TM MUX provides a time reference and signals for timing and coordinating the operation of the portions of the Thematic Mapper instrument. The multiplexer provides a 10.61 megahertz clock signal to the Scan Mirror Assembly which uses it as a time reference for controlling the highly precise scan mirror motion. A slower clock at 1/408 bit rate or 208.1 kHz, is also provided to the scan line corrector.

The Multiplexer receives signals from the Scan Mirror Electronics to indicate the beginning and end of the period in the Scan Mirror's travel when data should be taken. The "line stop" signal (indicating the end of the formatting period)

is buffered and retransmitted to the Scan Line Corrector to initiate the SLC motions which correct for overlap. A second signal, delayed from "line stop" by a programmable period, acts as a synchronization signal to the calibrator shutter. (The calibrator shutter places calibration light sources in telescope field of view during the turnaround period of the scan mirror. Multiplexer also provides a 208.1 kilohertz clock to the Thematic Mapper power supply. The power supply DC-to-DC converter synchronizes itself to this clock which in turn is synchronous with the Multiplexer's sample rate. This precaution reduces the probability of power supply noise appearing as coherent patterns in the resulting imagery.

1.2.1.2 Multispectral Scanner System

The Multispectral Scanner (MSS) subsystem gathers data by imaging the surface of the earth in several spectral bands simultaneously through the same optical system. Figure 1-6 is a simplified pictorial overview that includes the scanner functional block diagram. The MSS is a 4-band scanner operating in the solar-reflected spectral band region from 0.5 to 1.1 micrometer wave length. The four spectral bands are:

- Band 1 0.5 to 0.6 micrometers (visible)
- Band 2 0.6 to 0.7 micrometers (visible)
- Band 3 0.7 to 0.8 micrometers (near IR)
- Band 4 0.8 to 1.1 micrometers (near IR)

Bands 1 through 3 use photomultiplier tubes as detectors; Band 4 uses silicon photodiodes. There are six detectors in each band.

The MSS can operate in either the compressed or linear mode, and with either a gain of 1 times or 3 times. Table 1-1 (MSS Modes) shows the possible selections for the MSS bands 1 through 4

Table 1-1. MSS Modes

	LINEAR	COMPRESSED	GAINS	
			1X	3X
BAND 1	X	X	X	X
BAND 2	X	X	X	X
BAND 3	X	X	X	
BAND 4	X		X	

Figure 1-7 illustrates the dynamics of the scan pattern. The MSS scans cross-track swaths of 185 kilometers width, imaging 6 scan lines across in each of the 4 spectral bands simultaneously (24 scan lines total). The object plane is scanned by means of an oscillating flat mirror between the scene and the double-reflector telescope type of optical chain. The 14.9 degree cross-track field of view is obtained as the mirror oscillates.

The instantaneous field of view of each detector subtends an earth-area square of 83 meters on a side from the nominal orbital altitude (705 KM). Field stops are formed for each line imaged during a scan, and for each spectral band, by the square input end of an optical fiber. Six of these fibers in each of 4 bands are arranged in a 4 by 6 matrix in the focused area of the telescope.

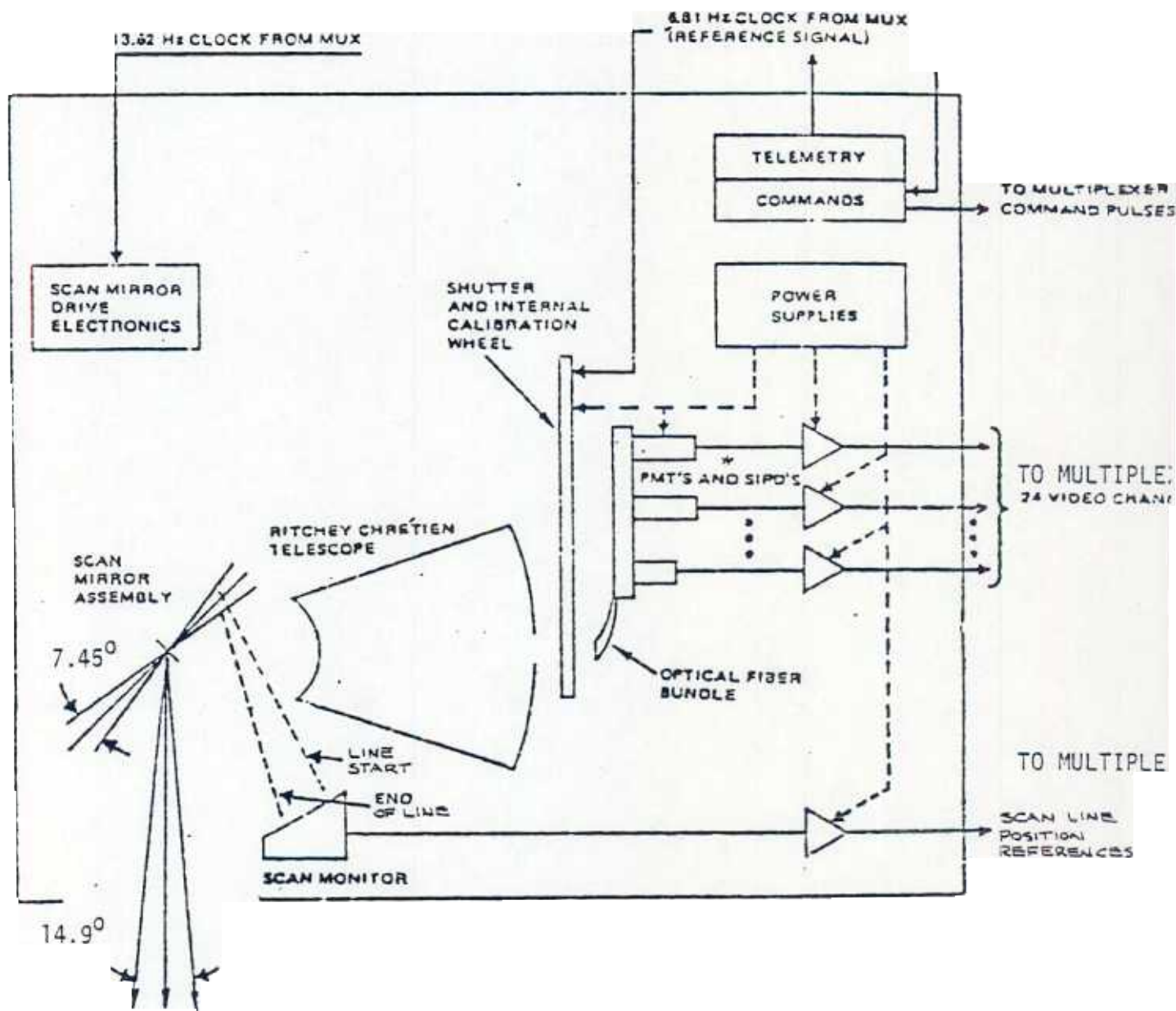

- * PMT- Photomultiplier Tubes (Bands 1 to 3)
- * SIPO's-Silicon Photodiodes (Band 4)

Figure 1-6. MSS Overview

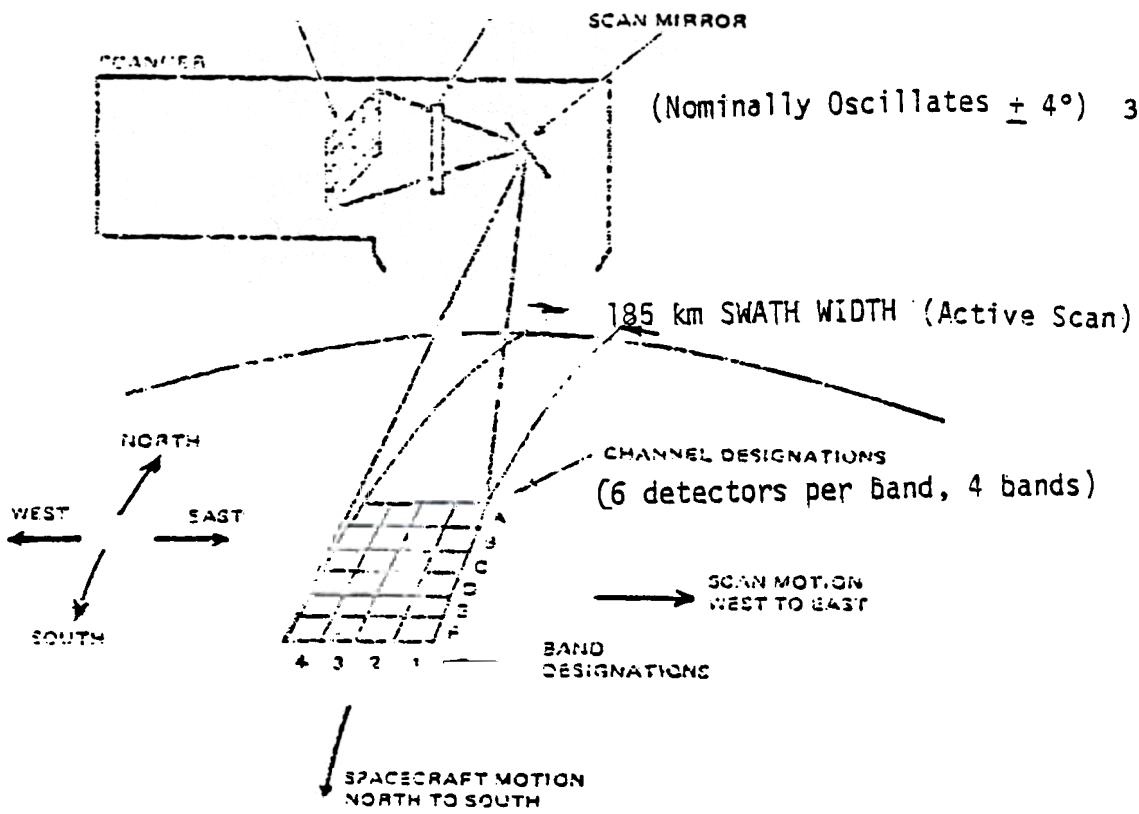

Figure 1-13. MSS Field Stop Pattern Projected on the Earth's Surface

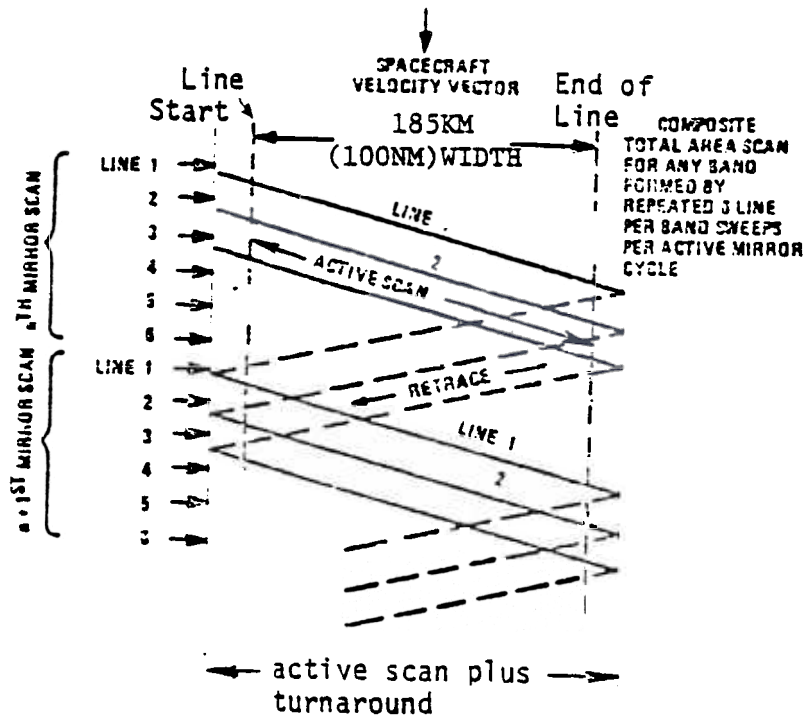

Figure 1-7. Ground Scan Pattern for a Single MSS Detector

Light impinging on each glass fiber is conducted to an individual detector through an optical filter, unique to the spectral band served. An image of a line across the swath is swept across the fiber each time the mirror scans, causing a video signal to be produced at the scanner electronics output for each of 24 channels. These signals are then sampled, digitized and formatted by the MSS multiplexer. The MSS multiplexer formats the video, sync code and time code

15 megabit/second serial data stream. The scanner functional block diagram is shown in Figure 1-8. The signals in bands 1 and 2 can be amplified by a factor of three upon command to increase response to low level scene radiance.

The along-track scan is produced by the orbital motion of the spacecraft. The nominal orbital velocity causes an along-track motion of the subsatellite point of 6.82 km/sec neglecting spacecraft perturbation and earth rotation effects. By oscillating the mirror at a rate of 13.62 Hz, the subsatellite point will have moved 501 meters along the track during the 73.42-millisecond active scan and retrace cycle. The width of the along track field-of-view of six detectors is

501 meters. Thus, complete coverage of the total 185 kilometer wide swath is obtained. The line scanned by the first detector in one cycle of the active mirror scan lies adjacent to the line scanned by the sixth detector of the previous mirror scan.

On-board calibration is accomplished as follows. During the retrace interval, the scan mirror makes the transition from east to west, a shutter wheel closes off the optical fiber view to the earth and a light source is projected on the fibers via a prism. A continuously variable neutral density filter is

swept across the light path so that each video channel carries a triangular pulse of about 10.2 milliseconds duration which begins with an abrupt transition black to white and descends monotonically back to black. The shutter is designed to rotate once for every two scans so that the calibration signals are available during alternate retrace intervals.

nominal shape of the calibration or gray wedge is shown in Figure 1-9. The actual shape and level varies somewhat for the detectors in the various spectral bands. The calibration wedge trailing edge density levels (digital decrease from 63 to 0, and appears once every 147 ms (alternate scans). The location of the CAL signal in the bit stream is determined by the rotation of the shutter and the physical location of the calibration lamp. The precise location of the CAL signal is not controlled by the multiplexer, and the CAL signal location within the bit stream may not be same for each scan. The calibration ramp versus characteristic can be processed to provide the required number of gray scale levels of descending half power levels for radiometric correction. Assuming that the calibration lamp intensity is constant, it is possible to obtain a check of the relative radiometric levels and also to equalize gain changes which may occur in the six detectors of a spectral band

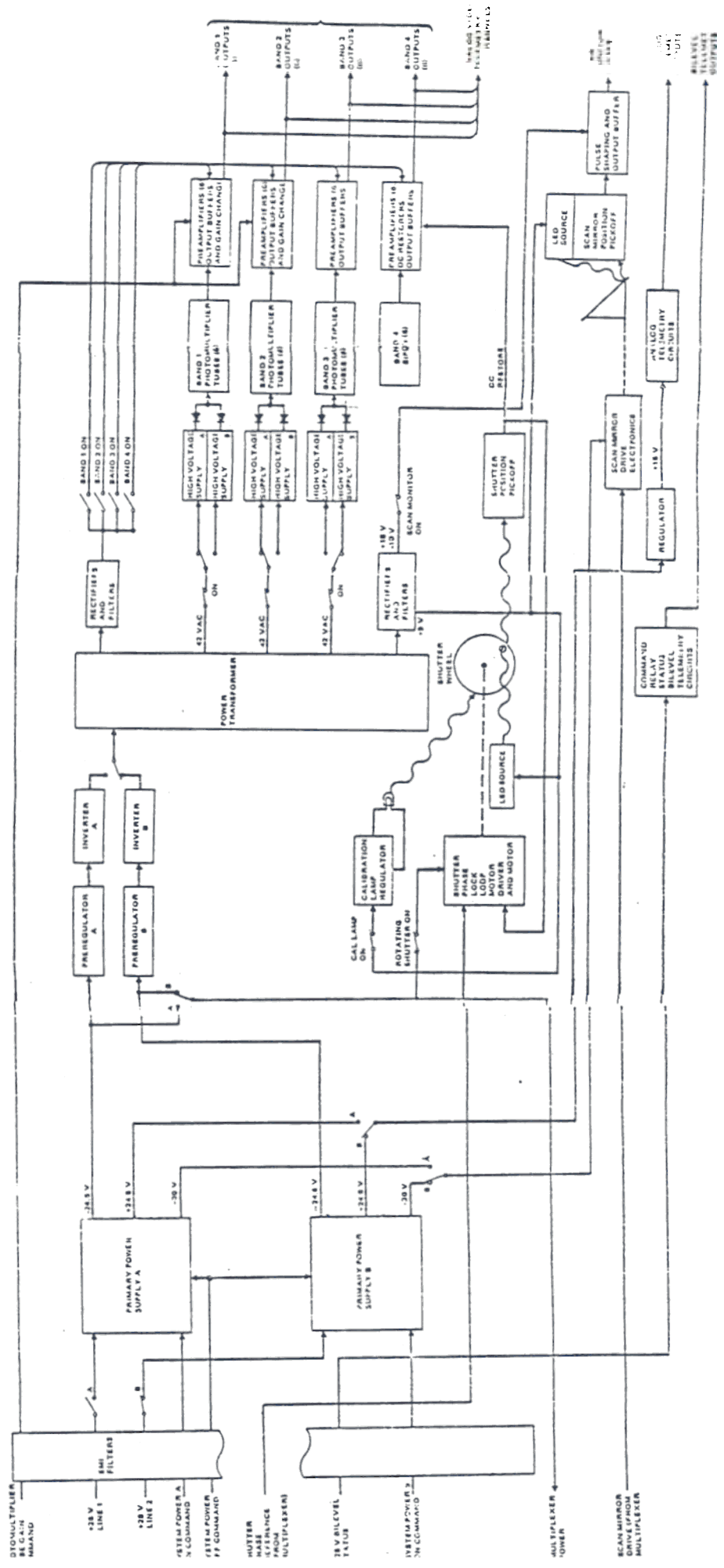

1.2.1.3 MSS Multiplexer

The MSS multiplexer provides to or receives from the spacecraft the signals listed below.

<u>SIGNAL</u>	<u>TO/FROM</u>
Data Signal	To spacecraft wideband and S-Band systems
Bit rate clock signal	To IM DPU
Time code envelope	To IM DPU
Time code clock	To IM DPU
Time code data signal	From IM DPU

Figure 1-10 illustrates these functional interfaces.

Figure 1-10. MSS Multiplexer Functional Block Diagram

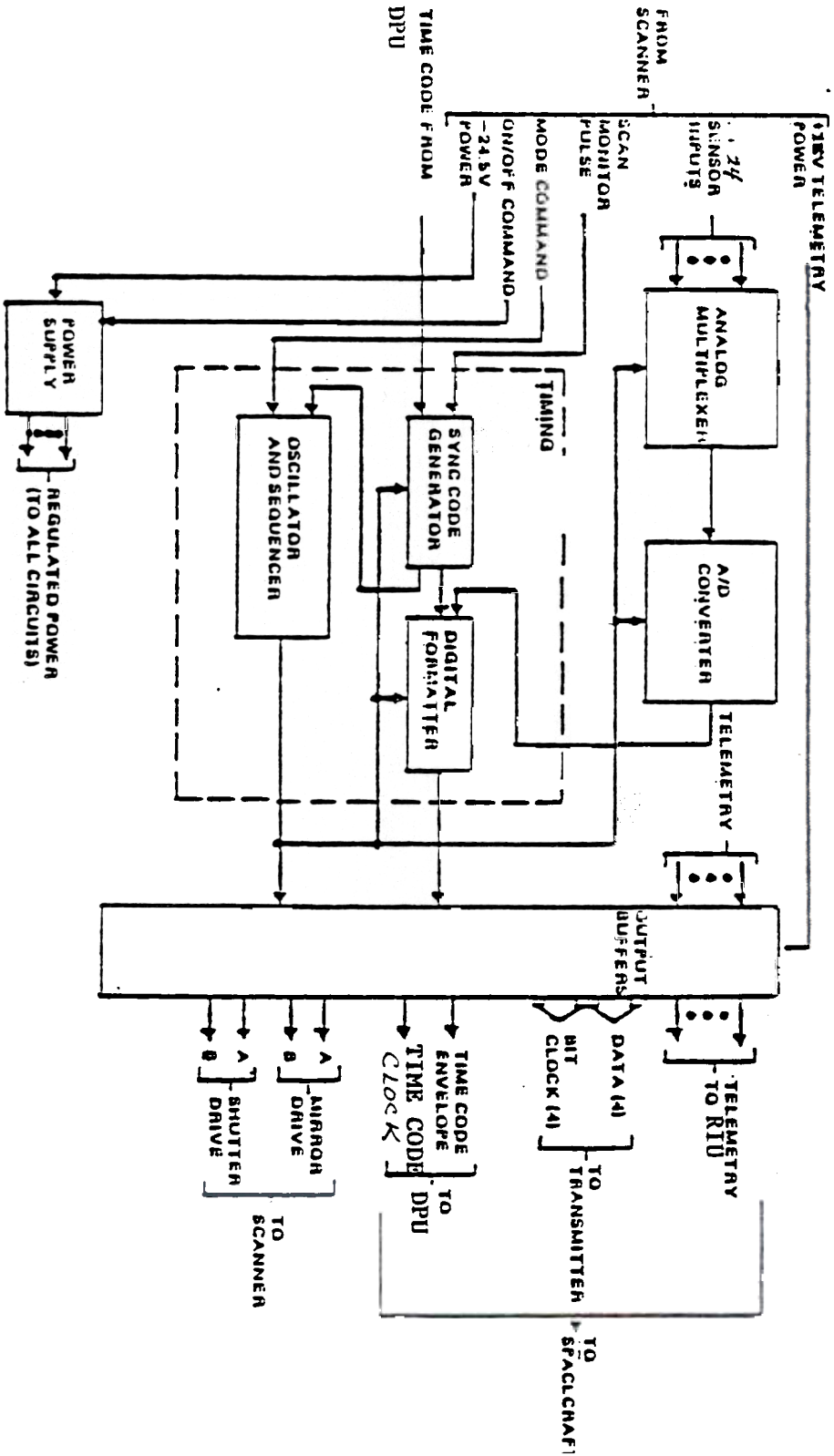

The MSS MUX receives analog video data from each of the six sensors in the four spectral scanner bands. The data in each band represents six scan lines with calibration inputs for each complete cycle of the scan mirror. The MUX inserts into the bit stream, the information required for ground synchronization. This includes the Preamble, the Line Start Code and the End Scan Code. The MUX, upon command, inserts a Mid Scan Code which identifies the center of the scan.

The MUX reads the 49-bit spacecraft time code generator, and inserts the returned time code into the data bit stream. The time code occupies the first 49 video word locations immediately following the line start code of each scan line.

The binary data bit stream from the MUX and a bit rate clock (15 MHz) is provided to the spacecraft wideband and S-Band systems. The MUX status and diagnostic outputs are relayed to the Flight Segment telemetry subsystem via the scanner. The MUX provides timing signals to the shutter motor, power inverter and scan mirror in the MSS scanner. The commutated samples of video in Bands 1-3 can be directed by command to either a signal compression amplifier or linear amplifier within the MUX prior to encoding. The advantage of signal compression is that it makes use of the photomultiplier tube noise characteristic, to provide better resolution at low light levels than would be obtained with linear quantization. By compressing the high light levels and expanding the lower levels, a better match of the quantization noise to the detector noise is achieved. Noise for the silicon diode detector channels of Band 4 are established by the equivalent load resistor noise and is best matched by the linear quantization.

The scanner generates scan monitor pulses which are used to synchronize the video with the mirror scan. The first scan monitor pulse marks the start of an active scan. Upon receipt of the first scan monitor pulse (SMP1), the multiplexer inserts a Line Start Code (LSC) in the serial bit stream. The LSC is the complement of the Preamble Word. A Minor Frame Sync Code follows the LSC and the MUX commutator is reset so that the channel for line "A" of the first band is always sampled first. The first 50 words of the first minor frame contains time code from the Digital Processing Unit (DPU).

The second scan monitor pulse (SMP2) identifies the mid-scan position of the scan mirror. When enabled by ground command, the multiplexer generates a Mid Scan Code and inserts it in the bit stream. The third scan monitor pulse identifies the end of an active scan. Upon receipt of the third scan monitor pulse (SMP3), the multiplexer generates an End of Line Code (ELC) and inserts it into the serial bit stream.

The word rate is maintained uniform from scan to scan and divides integrally into a scan cycle. The 13.62 Hz mirror drive signal is derived by the MUX from its 30 MHz master oscillator. Only the line start and minor frame synchronization need to be acquired by ground processing in each scan and this is facilitated by having the word synchronization information. A detailed description of the MSS data format is presented in Section 3.

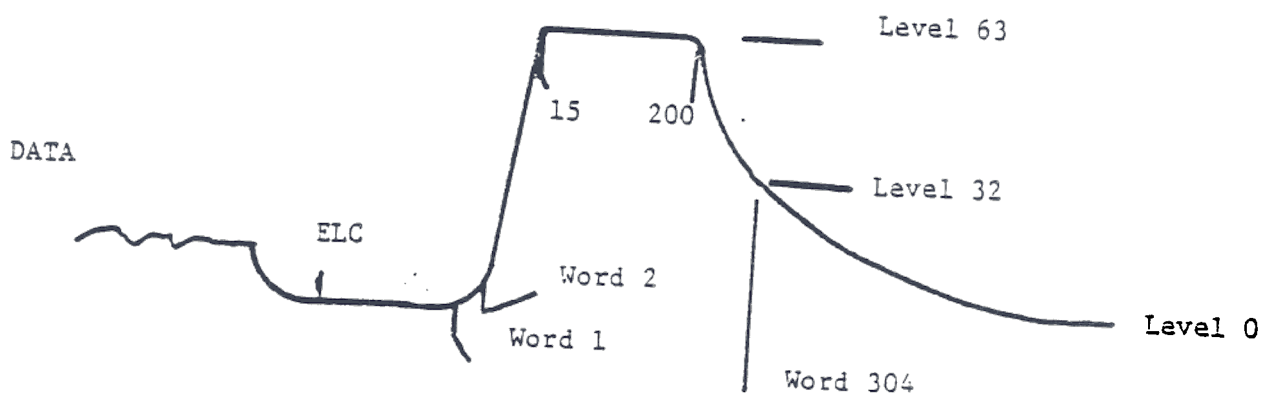

ELC= End of Line Code

Figure 1-9. Typical Calibration Wedge Curve

TO TDRS

TM & MSS
15003.4MHz+85MHz

AUTOTRACK
13775MHz+5MHz

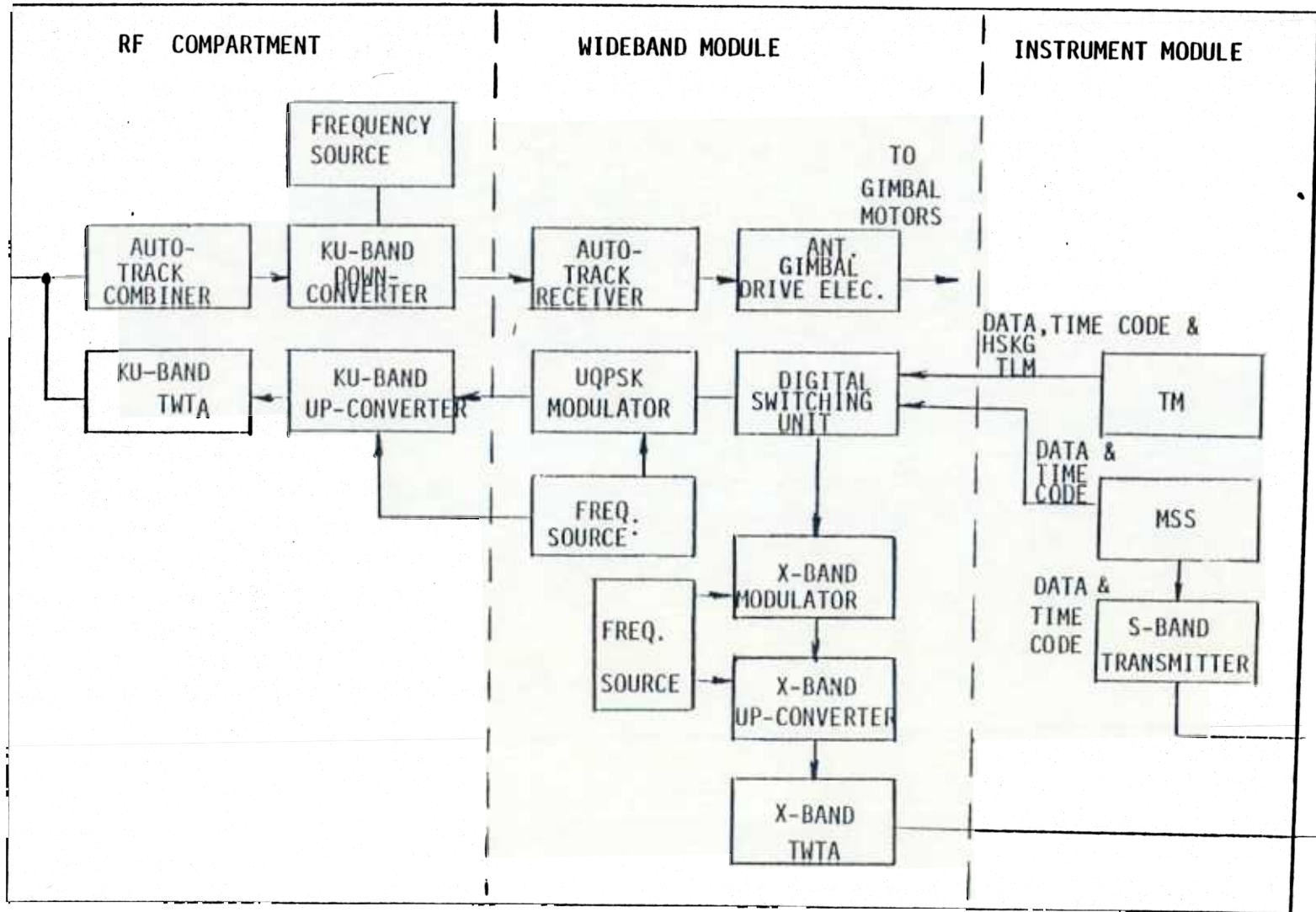

TO FOREIGN G.
GSTON,
TGS
2265.5+15MHz

to forei
G.S., TGS
8212.5+85MHz

FIGURE 1-11. WIDEBAND COMMUNICATIONS SUBSYSTEM

1.2.1.4 Wideband Communications Subsystem

The Wideband Communications Subsystem (WCS) receives digital data signals from the Thematic Mapper (TM) and the Multiplexer Scanner (MSS) sensors and transmits these data to the Tracking and Data Relay Satellite System (TDRSS) at Ku-band and/or to selected ground stations at X-band.

The WCS consists of a wideband module, an RF compartment and the gimbal drive assembly as shown in Figure 1-11.

wideband module contains the X-band transmission link equipment, signal and power control, gimbal drive electronics, the modulator portion of the Ku-band transmission link equipment, and the autotrack receiver.

RF compartment contains the Ku/S-band antenna, the Ku-band switching, diplexing, upconversion components, TWTA's, and downconverters for the Autotrack system. The RF compartment and Ku/S-band antenna are attached to the top of the antenna mast by means of the gimbal drive assembly, a two-axis rotary mechanism consisting of an elevation-over azimuth mount.

Direct Readout (S-band) link receives digital data and clock signals from the MSS and transmits the data to foreign stations, the GSFC Transportable ground station and to the Ground Spacecraft Tracking Data Network (GSTDN) at Goldstone, California and at Fairbanks, Alaska.

1.2.2 GROUND SEGMENT

The Landsat-D Ground segment at GSFC receives payload data via several options as described in Section 1.2.1 and illustrated in Figure 1-2. The options for data flow within the DMS and CSF and the formats to be detailed in Section 2.

1.2.2.1 Data Management System (DMS)

The DMS is capable of accepting data from many sources including data in time from the Transportable Ground Station (TGS) and from the TDRSS Ground Station via a Domestic Communication Satellite (DOMSAT) link. Image data is assessed for cloud cover by a fully automatic algorithm for Thematic Mapper data and a computer-aided, semi-automatic cloud cover assessment process for the Multi-Spectral Scanner (MSS). The computer-aided semi-automatic cloud cover assessment process may also be used for TM data to provide a continuous or intermittent check on the fully automatic process. Radiometric and geometric corrections in two of three map projections (two of the three are mutually exclusive) are computed for all imagery. All imagery is radiometrically corrected and formatted to archival high density tapes (HDT-A's) with ancillary and annotation data appended. A subset of Thematic Mapper (TM) data is selected for full geometric correction in any one of the map projections. Full image selection may be made for all imagery but sub-image (quadrant) selection may be made for CCT (Computer Compatible Tape) generation on TM only. The entire process is controlled using fully automated production scheduling with provision for complete manual supervisory and override

capability. A single centralized integrated data base and formal Data Base Management System (DBMS) supports the entire DMS and provides full management visibility into the production control and scheduling processes by interactive query, graphics displays, hard copy reports and catalogs.

The product generation will be described in Data Format Control Book Vol. VI, Products.

1.2.2.2 Control and Simulation Facility (CSF)

Payload data are provided to the CSF from the DMS (DRRTS) following bit synchronization and demultiplexing. Sensor wideband data will be quick-look evaluated in real-time during TGS data acquisition periods and in an off-line manner whenever DOMSAT data transfer occurs. Within the CSF, the "quick look" (Q-L) display provides real-time/playback data monitoring capability, permitting prompt detection of faulty detectors in the flight instrument, and a visual indication of the degree of quality of the incoming raw data by on-line contents inspection. The Q-L display hardware, illustrated functionally in Figure 1-12 provides data selection and display on the detector data streams provided by the DMS.

The Demux (located in the DMS/DRRTS) is a high-speed frame synchronizer and data decommutator which accepts data and bit rate clock directly from the Bit Synchronizer. The Demux provides:

1. Search and acquisition for preamble, scan line start code, minor frame sync, and end scan code.

2. Decommuration and bit inversion
3. Extraction of time code.

Thus, each Demux can send one selected demultiplexed detector data stream and the corresponding "stripped" S/C time code data to the CSF for quick look evaluation. In addition, the Demux also has a limited error detection capability.

The Data Select Unit (DSU) provides: data select control, display control, and printer control. The high speed digital printer is used to provide hard copy records of time code.

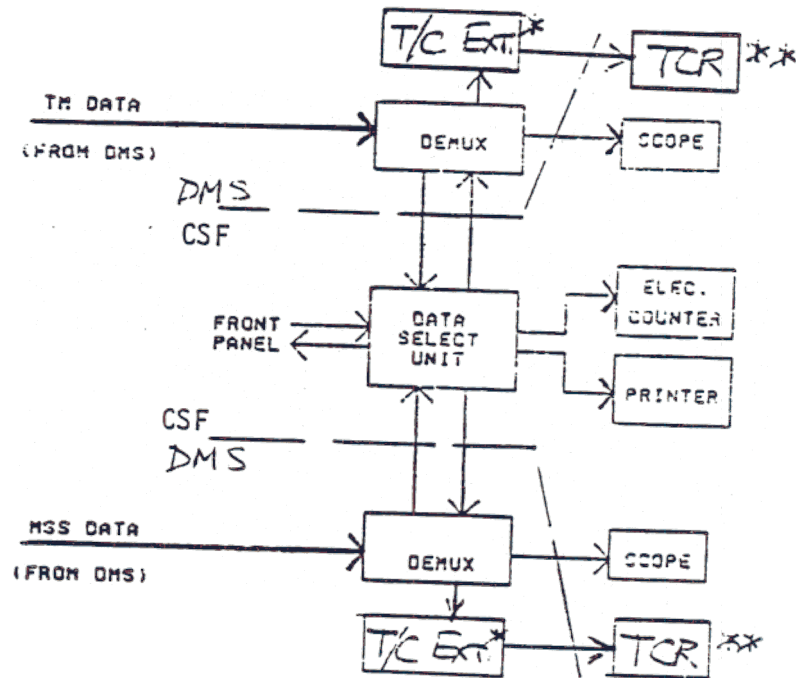

Note: * Time code extractor
 ** Time code recorder

Figure 1-12. CSF "Quick-Look" Hardware Block Diagram

SECTION 2
THEMATIC MAPPER DATA FORMATS

GENERAL

Thematic Mapper outputs a serial bit stream and clock to the Wideband Communication System. The data rate is $84.903 \pm 0.080 \times 10^6$ bits per second. The format of the data is defined in Section 2.2 and the data content is described in Section 2.3

TM FORMAT

Thematic Mapper data is partitioned into major frames. Each major frame is identified by a major frame synchronization (sync) code. Major frames are of varying length and contain the following data:

Major Frame Sync Codes
Time Code
Video Data
Mid-Scan Code (optional)
Video data
End-Scan Code
Line Length
Post-Amble

These data are defined in the following paragraphs.

2.2.1 MAJOR FRAME SYNC CODE

Major frame sync is a unique 102 word pattern. The 816 bits are those defined in Figure 2-1. The major frame sync identifies the start of each major frame. The SYNC code is generated by a 10 bit shift register whose first and fourth bits are exclusive 'or-ed' to produce the eleventh bit. The seed code, starting with the first bit is 0011110110. The code is synchronized to the minor frame so that the last ten bits are ones. Major Frame Sync can interrupt any data at word boundaries. Major Frame sync occurs within $2 \pm 1/2$ word times of the scan mirror start position. Major Frame sync is not encoded.

2.2.2 MINOR FRAME FORMAT

minor frames (see Figure 2-2) are comprised of 816 bits portitioned into 102, 8 bit, words. The first 4 words are minor frame synchronization code. The sync code is, starting with the first bit of first word:

00000010 00110111 00010110 11010001

Minor frame sync code words are not encoded.

fifth word in each minor frame contains data from one of the four Band 6 sensors. The Band 6 sensors are submultiplexed in the order: Sensor 1, Sensor 3, Sensor 2, Sensor 4 commencing with minor frame 1 (the 2nd minor frame) of each major frame. The 8 bits of data in the Band 6 word are encoded as described in paragraph 2.2.8.

The sixth word in each minor frame contains either a minor frame counter number or a word provided by the spacecraft Digital Processing Unit (DPU). The minor frame counter commences with a count of "zero" at minor frame number 16 (the minor frame in the major frame) and is incremented by 1 and inserted every sixteen minor frames.

The DPU word is either SYNC, FILLER or PCD. The words are output from the DPU in the order FILLER, SYNC, PCD, PCD, PCD, FILLER, FILLER... SYNC words are hexadecimal 16's (00010110). FILLER words are hexadecimal 32 (00110010). PCD words are repeated twice (3 words total) and represent 8 bits of Payload Correction Data. DPU and counter words are encoded as described in paragraph 2.2.8. The last 96 words in each minor frame contains one sample from each of the 16 detectors in Bands 1, 2, 3, 4, 5 and 7. These data are formatted as shown in Figure 2-2. Video data commences with minor frame number 7 (eighth minor frame of the major frame) and continues, with interruptions, until post-amble data. Video data is interrupted by Time Code End Scan Code, and Line Length each major frame, and Mid Scan Code if selected by command. Video data is encoded as described in paragraph 2.2.8.

Bit # 1

00111101101101000000010100001011010101000111110111
10010010110000010011001000101000110110111000000111
1000111011111110010000110001011011101000011010101
00111100101101100100000100010010011000000101100010
10011101100111000101111110101000101110110101100001
10011011010100000111010011110100110101001001110000
01111100111001101111010001010101101111100001001110
10001110101111101101001000010000101001010110001110
0111111011000010001101001110010011110000110111011
00011000111101111101001001010000001101000110010111
01001011010001000101100110100101001000110000111011
01111000001011100101011100111011101110011001110101
01110111101100101000100110110001000011100101111100
10100110011001010101001111110011000110101111001101
0110100110001001011100001011110101010101111111010
00001010100101111000101011110111010100110111001000
1110001111111111

Bit # 816

Figure 2-1. TM PN Code

MNF SYNC CODE

00000010	00110111	00010110	11010001	BAND G	PCD or Counter Word
1-1 *	2-1	3-1	4-1	5-1	7-1
1-3	2-3	3-3	4-3	5-3	7-3
1-5	2-5	3-5	4-5	5-5	7-5
1-7	2-7	3-7	4-7	5-7	7-7
1-9	2-9	3-9	4-9	5-9	7-9
1-11	2-11	3-11	4-11	5-11	7-11
1-13	2-13	3-13	4-13	5-13	7-13
1-15	2-15	3-15	4-15	5-15	7-15
1-2	2-2	3-2	4-2	5-2	7-2
1-4	2-4	3-4	4-4	5-4	7-4
1-6	2-6	3-6	4-6	5-6	
1-8	2-8	3-8	4-8	5-8	
1-10	2-10	3-10	4-10		
1-12	2-12	3-12	4-12		
1-14	2-14	3-14	4-14	5-14	
1-16	2-16			5-16	7-16

MINOR FRAME FORMAT

Typical Band/Sensor Designation

Word progression within MNF is from top of table to bottom going from left to right within each row

Figure 2-2. TM Minor Frame Format

2.2.3 TIME CODE FORMAT

The six minor frame immediately following Major Frame Sync contain the time at which the scan mirror intercepts the start position. The first six words of each time code minor frame are the same as a defined in paragraph 2.2.2 (i.e. minor frame sync Band 6 and DPU words)

The remaining 96 words contain 16 bits of time code information. Each bit is expanded (replicated) to fill six words (48 bits). The time code information is formatted as shown in Figure 2-3. It can be seen from this figure that the data in minor frames 1 and 6 form a guard band as do the data in the columns formed by words 7 thru 12 and 97 thru 102. All other columns except the two formed by words 49 thru 54 and 91 thru 96 represent Binary Coded Decimal (BCD) words with minor frame 2 containig the eight weight bit, frame 3 the four weight bit, frame 4 the two weight and frame 5 the unit weight bit. The 96 time code words in each time code minor frame are encoded as described in paragraph 2.2.8.

MNF # 1	MNFS BAND 6 PAYLOAD CORRECTION DATA	0	0	0	0	0	0	0	0	1	1	1	1	1	1	1	1
MNF # 2	MNFS BAND 6 PAYLOAD CORRECTION DATA	0	10 DAY-2 ³	10 HRS-2 ³	10 MIN-2 ³	10 SEC-2 ³	100 MS-2 ³	1 MS-2 ³	1	100 DAY-2 ³	1 DAY-2 ³	1 HR-2 ³	1 MIN-2 ³	1 SEC-2 ³	10 ms-2 ³	.0625 ms-2 ³	1
MNF # 3	MNFS BAND 6 PAYLOAD CORRECTION DATA	0	10 DAY-2 ²	10 HRS-2 ²	10 MIN-2 ²	10 SEC-2 ²	100 MS-2 ²	1 MS-2 ²	1	100 DAY-2 ²	1 DAY-2 ²	1 HR-2 ²	1 MIN-2 ²	1 SEC-2 ²	10 ms-2 ²	.0625 ms-2 ²	1
MNF # 4	MNFS BAND 6 PAYLOAD CORRECTION DATA	0	10 DAY-2 ¹	10 HRS-2 ¹	10 MIN-2 ¹	10 SEC-2 ¹	100 MS-2 ¹	1 MS-2 ¹	W	100 DAY-2 ¹	1 DAY-2 ¹	1 HR-2 ¹	1 MIN-2 ¹	1 SEC-2 ¹	10 ms-2 ¹	.0625 ms-2 ¹	1
MNF # 5	MNFS BAND 6 PAYLOAD CORRECTION DATA	0	10 DAY-2 ⁰	10 HRS-2 ⁰	10 MIN-2 ⁰	10 SEC-2 ⁰	100 MS-2 ⁰	1 MS-2 ⁰	Z	100 DAY-2 ⁰	1 DAY-2 ⁰	1 HR-2 ⁰	1 MIN-2 ⁰	1 SEC-2 ⁰	10 ms-2 ⁰	.0625 ms-2 ⁰	1
MNF # 6	MNFS BAND 6 PAYLOAD CORRECTION DATA	0	0	0	0	0	0	0	0	0	0	0	0	0	0	0	0

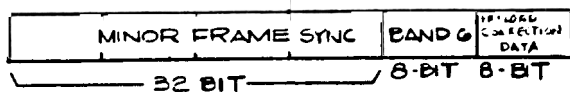

16 SLOTS

Spacecraft ID W Z
 Landsat-D 1 0
 Landsat-D' 0 1

TYPICAL SLOT- EACH BINARY SLOT VALUE IS EXPANDED TO 48-BITS.
 ALL TIME CODE INFORMATION IS REPRESENTED AS BCD
 DIGITS, EACH DIGIT EXPANDED TO 48-BITS.

FIGURE 2-3 TM TIME CODE FORMAT

2.2.4 MID-SCAN CODE FORMAT

The mid-scan code is a fiducial mark that can be inserted, by ground command, in the data stream to mark the center of the mirror sweep. Mid-scan code consists of 48 words of white (level 255) followed by 48 words of black (level 0). Mid-scan will occur within two to nine word times of scan mirror center position. Mid-scan code may interrupt video data at word boundaries. Mid scan code does not replace minor frame sync, Band 6 data or PCD data. Mid-scan code is encoded as defined in paragraph 2.2.8.

2.2.5 END-SCAN CODE FORMAT

The End-Scan code is a fiducial mark that is always inserted in the data stream to mark the end of mirror sweep. End scan code (Figure 2-4) consists of 48 words of black (level 0), followed by 48 words of white (level 255), followed by 48 words of black and ending with 48 words of white. End scan code occurs within two to nine words of scan mirror and position. End scan code may interrupt video data at word boundaries. End scan data does not replace minor frame sync, Band 6 or PCD data. End-Scan Code is encoded as defined in paragraph 2.2.8.

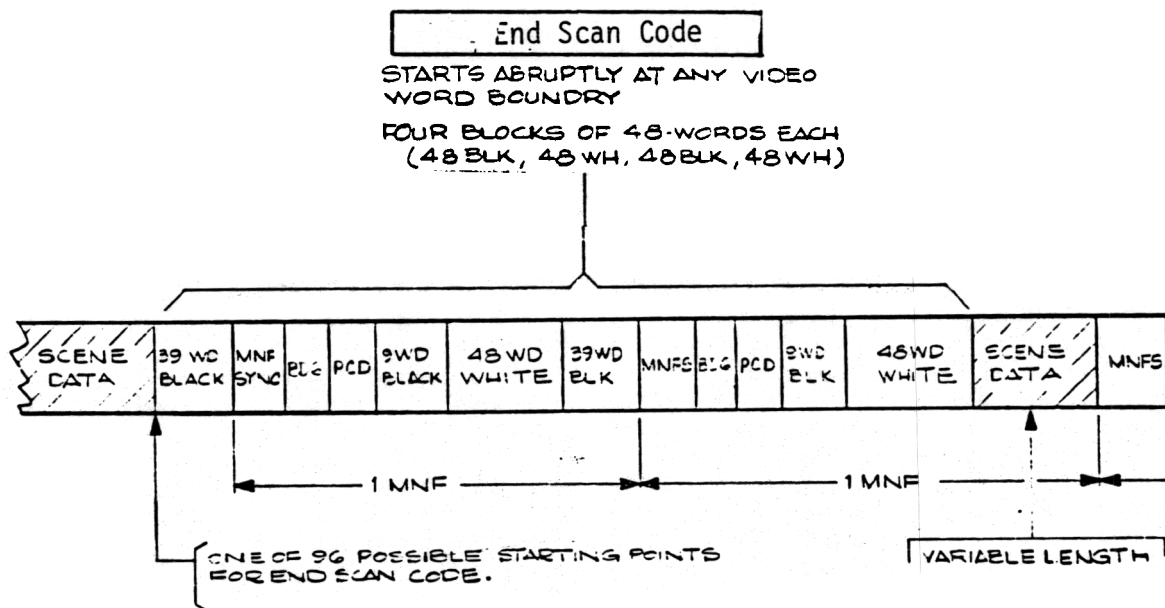

Figure 2-4. TM End Scan Code Format

LINE LENGTH DATA

first two complete minor frames following the minor frame in which the End scan code is completed, contain Line Length data (see Figure 2-5). Line Length data is comprised of 32 bits. Each bit is expanded (by repetition) to fill six words hence requiring 192 words. Line Length data does not replace minor frame sync, Band 6, and DPU or frame counter words. Line Length data is partitioned into three fields as shown in Figure 2-5. The first field "SHSERR", is the second half scan error (in counts) from a nominal of 161,165. The second field "FHSERR", is the first half scan error (in counts) from a nominal of 161,164. Both fields are comprised of a sign bit followed by 11 binary weighted bits, MSB first. Negative magnitudes (sign bit = 1) are two's complement. Scan errors can be converted to timing errors by multiplying the number of counts by twice the word period. The third field "SCANDIR" is the scan direction associated with the previous major frame. A forward scan (West to East descending node) is denoted by all one's. A reverse scan is denoted by all zero's. Line Length data is encoded as described in paragraph 2.2.8.

LINE LENGTH/SCAN DIRECTION

BEGINS WITH FIRST MNF AFTER END SCAN CODE
 32 BITS OF INFORMATION EXPANDED BY 6 WD/BIT
 TO 192 WORDS.
 APPLIES TO PREVIOUS SCAN LINE.

SHSERR - SECOND HALF SCAN ERROR COUNT
 DIFFERENCE FROM NOMINAL LENGTH FROM
 MID SCAN TO END SCAN (161165).

FHSERR - FIRST HALF SCAN ERROR COUNT
 DIFFERENCE FROM NOMINAL LENGTH FROM
 START SCAN TO MID SCAN (161164).

12 BIT WORD

- 1 SIGN BIT (0=PLUS, 1=MINUS)
- 11 BIT MAGNITUDE MSB 1ST NEGATIVE
 VALUES ARE TWO'S COMPLEMENT.
- 1 COUNT = 2 WORD PERIODS.

SCANDIR - SCAN DIRECTION 8 BITS
 ALL 1'S = FORWARD SCAN
 (WEST TO EAST AT DESCENDING NODE)
 ALL 0'S = REVERSE SCAN

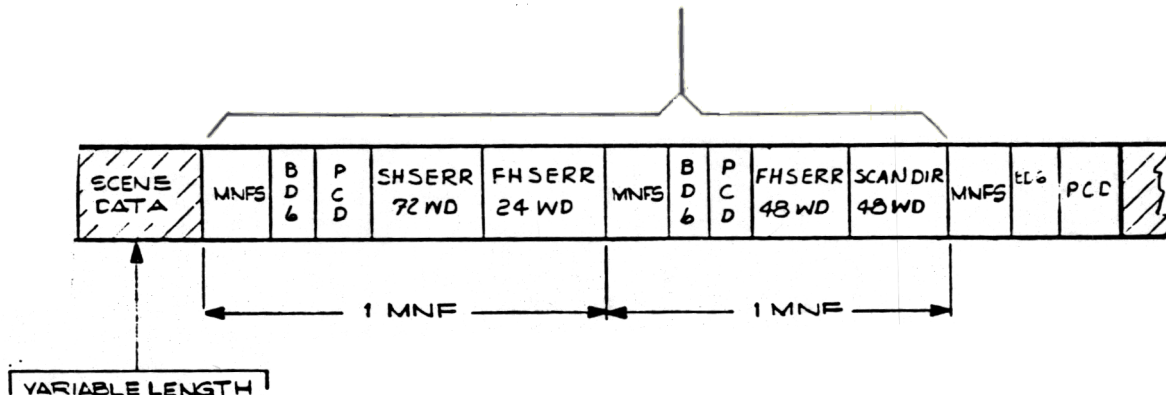

SHSER = Second half scan error

FHSER = First half scan error

Figure 2-5. TM Line Length/Scan Direction Code Format

2.2.7 POST-AMBLE DATA

Post-Amble data begins at the 960th minor frame following End Scan code. Ambler continues until it is interrupted by Major Frame Sync. Major frame will interrupt Post Amble only at word boundaries. Post-Amble minor frames contain the standard minor frame sync words (4), Band 6 data and PCD or Frame Counter words. The remaining words of each minor frame shall contain the inverse of the PN code (\overline{PN}) shown in Figure 2-1. The \overline{PN} code data is not encoded. The \overline{PN} code data starts with the 49th bit of the pattern and is reset at each minor frame

2.2.8 ENCODING

Specific TM words are encoded. Encoding consists of inverting the four least significant bits of the word and exclusive "or-ing" the resultant word with PN code shown in Figure 2-1. The PN code used in the exclusive or is synchronized to and reset each minor frame so that the last 10 bits available are all ones. The following TM words are not encoded:

Major Frame Sync

2. Minor Frame Sync

SECTION 3

MULTI-SPECTRIAL SCANNER DATA FORMATS

GENERAL

The MSS bit stream is created by the MSS Multiplexer at a nominal $15.625 \pm 0.01\%$ megabits per second. The bit stream is grouped into six bit words, and for image data, 150 words (6 rows of 25 words each) are grouped to form a Minor Frame. The Minor frames are grouped to form a Major Frame. And one Major frame contains the information for one complete scan of the MSS mirror which requires a nominal 75.42 milliseconds.

MSS MAJOR FRAME FORMAT

One MSS Major Frame contains the information generated during one complete sweep of the MSS scan mirror. Figure 3-1 shows the content of a major frame. The scanner generates scan monitor pulses which are used by the multiplexer to synchronize the scene data with the position of the scan mirror.

Drawing 47E253714 (Revision C dated 10/27/80) Multispectral Scanner Data Format contains the specifications for the MSS data format. This drawing will be checked for later revisions

Figure 3-1 shows that the first part of a major frame contains the preamble which is the word (000111) repeated and not grouped into minor frames. The first scan monitor pulse occurs about 11.4 milliseconds after the start of the preamble. Upon the receipt of the first scan monitor pulse, the multiplexer

inserts the Line Start Code Word (111000_2) into the serial bit stream. After the Line Start Code, the multiplexer groups the bit stream into minor frames. And minor frames continue until the start of the Preamble for the beginning the major frame.

code information is contained in the first fifty (50) words of the first minor frame following the Line Start Code. A complete time code occupies two contiguous major frames, and is reformatted in alternate pairs of major frames

When enabled by ground command and upon receipt of the second scan monitor pulse, the multiplexer inserts a Mid Scan Code into the bit stream which preempts scene data. The third scan monitor pulse signals the end of the valid scene data, and the multiplexer inserts the End Scan Code in the scene data bit stream. The End Scan Code preempts scene data.

The minor frames immediately following the End Scan Code, contain about eleven (11 milliseconds of invalid scene data

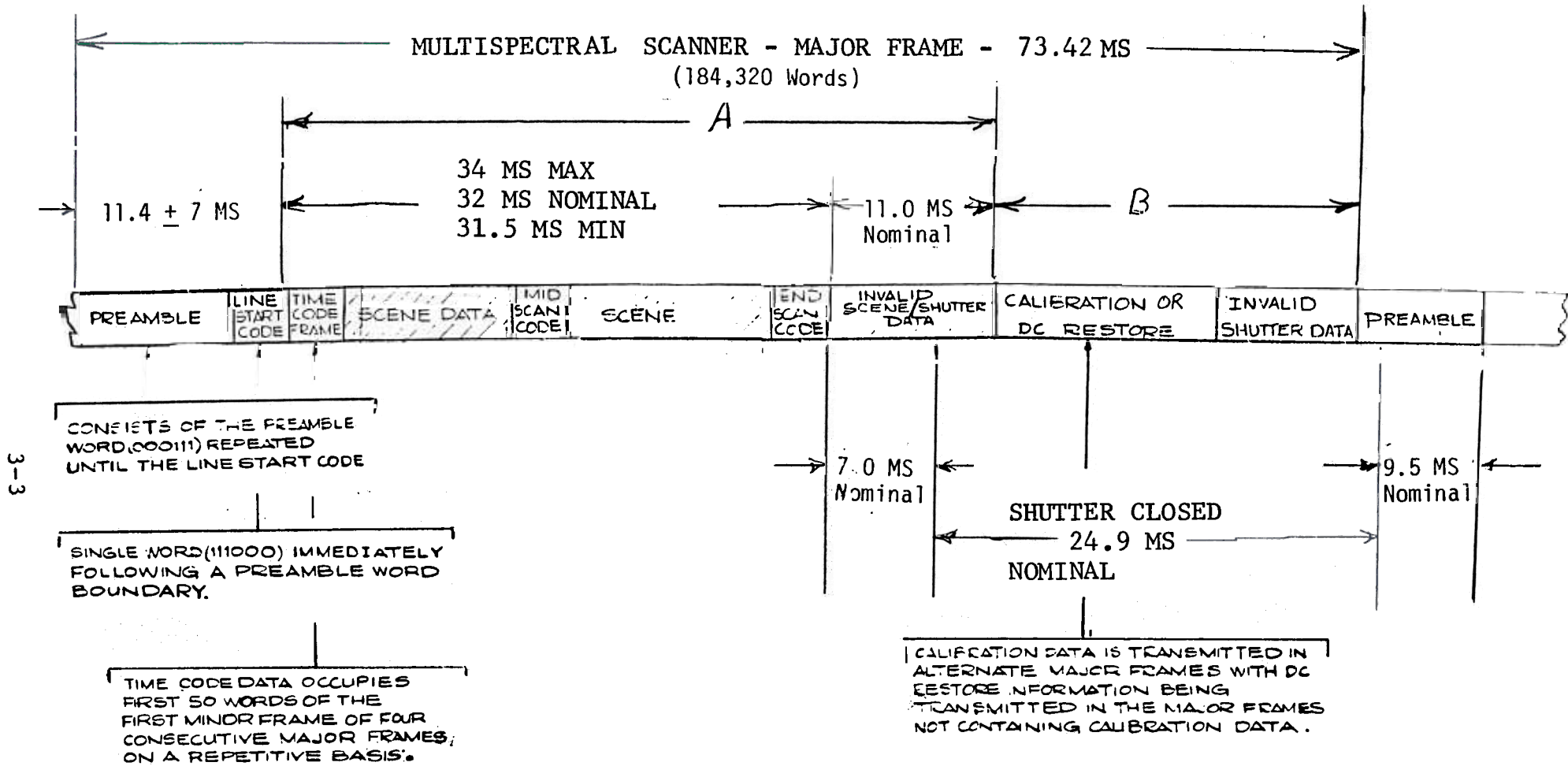

NOTE: MID SCAN & END SCAN CODES
CONSIST OF 100 WORDS OF BLACK FOLLOWED
BY 100 WORDS OF WHITE.

See Drawing #47E253714 - Multispectral Scanner Data Format
Revision C, dated 10/27/80

DIMENSION	A	B
CALIBRATION	42.8 ± 2 MS	10.2 ± 2 MS
DC RESTORE	43.3 ± 2 MS	20.0 ± 2 MS

FIGURE 3-1 MSS MAJOR FRAME FORMAT

The MSS shutter closes about seven (7) milliseconds after ELC and remains closed for about 24.9 milliseconds.

While the shutter is closed and about eleven (11) milliseconds after the End Scan Code, either DC RESTORE or CALIBRATION information is inserted into the MSS image bit stream. The DC Restore and Cal information appears in alternate major frames.

After the DC Restore or calibration information and exactly 184,320 words from the start of a major frame, the multiplexer begins the Preamble to start the next major frame.

3.2.1 PREAMBLE

The preamble is the first segment of a major frame, and it consists of the word 000111 repeated until the first scan monitor pulse is received from the scanner.

3.2.2 LINE START CODE

Following the receipt of the first scan monitor pulse and at the end of a preamble word, the Line Start Code is inserted into the bit stream. The LINE START CODE is the word 111000 and the occurrence of six ones (111111) signals the start of the scene data.

Upon the receipt of a SCAN MONITOR OFF command (RIU #7 Channel 07), the MSS scanner stops generating scan monitor pul, and the multiplexer generates a substitute Line Start Code that is inserted in the bit stream. The substitute

Line Start Code is located 11.4 milliseconds after the start of the PREAMBLE. In this mode, no MSC or ELS is inserted into the serial bit stream.

EACH MNF CONSISTS OF 150 WORDS (6 BITS PER WORD)

144 WORDS VIDEO DATA

1 WORD MINOR FRAME SYNC

1 WORD MINOR FRAME SYNC COMPLEMENT

4 WORDS (UNUSED WORDS)

(DATA TRANSMISSION ORDER IS FROM LEFT TO RIGHT TOP TO BOTTOM WITHIN TABLE)

MNFS	1A	2A	1B	2B	1C	2C	1D	2D	1E	2E	1F	2F	3A	4A	3B	4B	3C	4C	3D	4D	3E	4E	3F	4F
ID	1A	2A	1B	2B	1C	2C	1D	2D	1E	2E	1F	2F	3A	4A	3B	4B	3C	4C	3D	4D	3E	4E	3F	4F
ID	1A	2A	1B	2B	1C	2C	1D	2D	1E	2E	1F	2F	3A	4A	3B	4B	3C	4C	3D	4D	3E	4E	3F	4F
MNFS	1A	2A	1B	2B	1C	2C	1D	2D	1E	2E	1F	2F	3A	4A	3B	4B	3C	4C	3D	4D	3E	4E	3F	4F
ID	1A	2A	1B	2B	1C	2C	1D	2D	1E	2E	1F	2F	3A	4A	3B	4B	3C	4C	3D	4D	3E	4E	3F	4F
ID	1A	2A	1B	2B	1C	2C	1D	2D	1E	2E	1F	2F	3A	4A	3B	4B	3C	4C	3D	4D	3E	4E	3F	4F

MNFS = 001011

MNFS = 110100

ID Code:

LANDSAT D = 001100

LANDSAT D' = 110011

NOTE:

The value for sensor data range from 000000 being the least positive input value and 111111 being the most positive input value. The values are transmitted with their center two bits inverted MSB first.

Figure 3-2 MSS MINOR FRAME Format

If the SCAN MONITOR is ON, and the multiplexer fails to receive a line start scan monitor pulse, the multiplexer will, after searching for an additional 7 ms, insert a substitute Line Start Code.

3.2.3 MINOR FRAME

Figure 3-2 shows the format of a typical Minor Frame of MSS image data. A minor frame is made up of 150 6-bit words divided into six rows of 25 words each. The first word of each row is reserved for minor frame sync or for spacecraft identification. The first word of row one contains the Minor Frame Sync (MNF) word (001011). The first word of row number four contains the complement of the Minor Frame Sync (110100). The first word of rows two, three, five and six contain Spacecraft Identification. Landsat D is six bits of zeros with the center two bits inverted (001100), and Landsat D Prime is six bits of ones with the middle two bits inverted (110011).

Words 2 through 25 contain either time code or scene data. The scene information is encoded in a six bit word and the middle two bits are inverted.

3.2.4 TIME CODE

The first 50 words of the first minor frame of each major frame contains time code from the DPU. Figure 3-3 shows the time code format. A single time code is divided into two parts. The first part is transmitted in the major frame i and the next major frame $i + 1$. Major Frames $i + 2$ and $i + 3$ contain Time code but in a different format. The Time Code format is repeated every fourth Major Frame.

The Time Code Format includes a 4 bit Spacecraft Identification Code. As shown in Figure 3-3, bits 1 and 2 are contained in the Source ID field of line i , and bits 3 and 4 are contained in the Source ID field of line $i+2$.

$$\begin{aligned} \text{LANDSAT-D} &= 1110_2 \text{ and} \\ \text{LANDSAT-D}^1 &= 110^1_2. \end{aligned}$$

3.2.5 SCENE DATA

Figure 3-2 shows the format of a typical Minor Frame of MSS scene data. A minor frame consists of 6 rows of 25 words each. Word one is reserved for minor frame sync or spacecraft identification. Words 2 through 13 contain scene samples A through F from bands 1 and 2 (band interleaved). Words 14 through 25 contain sample A through F from bands 3 and 4 (band interleaved).

3.2.6 MID SCAN CODE

When commanded on (MID SCAN CODE ON), the MUX will insert a MID SCAN CODE in the MSS bit stream. Upon the receipt of a Middle of Scan Monitor Pulse from scanner, and following the end of the current word, the MUX inserts the MID SCAN CODE into the bit stream. For the next 100 words, the MUX transmits the black sensor level (code 001100). In the next 100 words, the MUX transmits the white sensor level (code 110011). The MID SCAN CODE starts at any word boundary. Minor Frame Sync Words are not preempted, and the total length of a MID SCAN CODE is 200 words. Figure 3-4 shows the MID SCAN CODE Format.

3-9

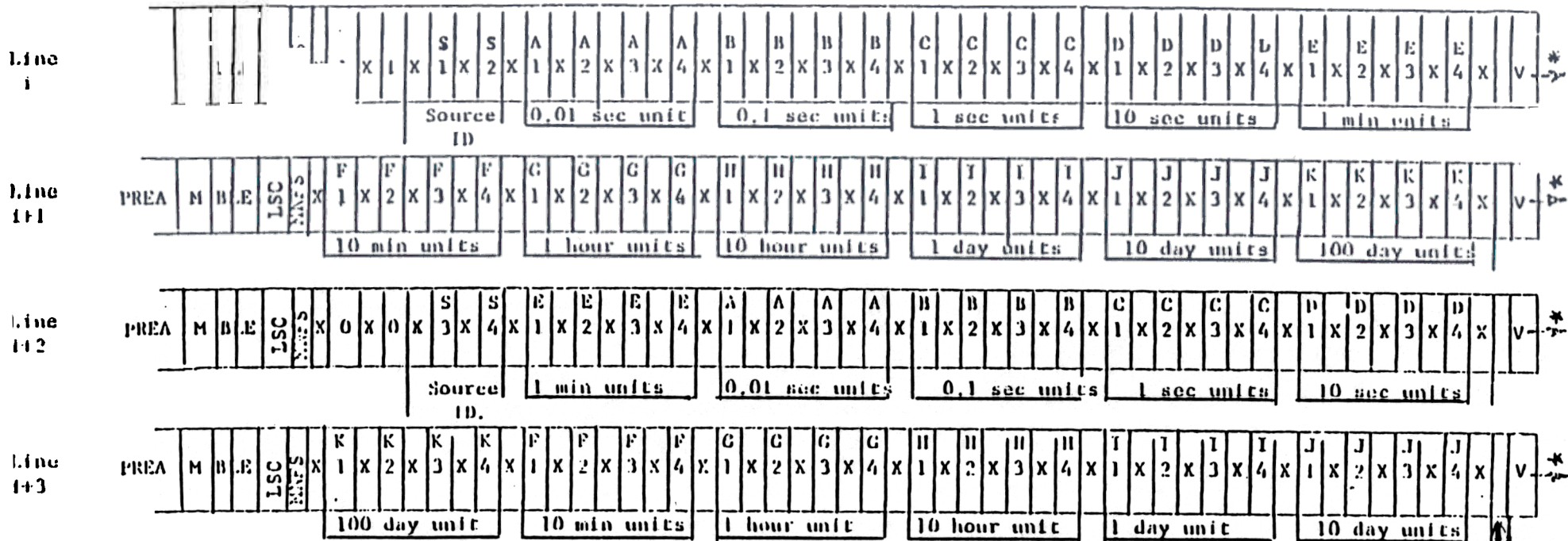

Time Code:
Update Every
1+2n Lines
where n = 1,2,3...

- Notes:
1. LSB first in time (TC units only)
 2. Coding

	0	1
Max. Internal	000000	111111
Max Output	001100	110011
Demux Output	000000	111111
 3. No data during time code - ...
 4. Video data - V
 5. Line start code - LSC
 6. Source ID S3 S4
 LANDSAT D 0
 LANDSAT D' 0 1

Notation

- A = hundredths of seconds
- B = tenths of seconds
- C = units seconds
- D = tens seconds
- E = units minutes
- F = tens minutes
- G = units hours
- H = tens hours
- I = units days
- J = tens days
- K = hundreds days
- S = Source Identification

Spacecraft ID
LANDSAT D = data "0"
LANDSAT D' = data "1"

LSD-MPC-012

* Video to end of scan

SVS-10126
Volume V
31 July 1981

3.2.7 END SCAN CODE

When the scan mirror reaches the end of the image scan, the scanner sends an end of scan monitor pulse to the multiplexer. The multiplexer upon receipt of the end of scan monitor pulse, preempts the sensor data and inserts the END CODE. The ELC is identical to the MID SCAN CODE shown in Figure 3-4. After the ELC, invalid sensor data is transmitted until calibration data or preamble is encountered.

3.2.8 CALIBRATION OR DC RESTORE

Nominally, eleven milliseconds after the ELC and on every other major frame, 10.2 milliseconds of calibration data are inserted in the major frame. A wedge shaped calibration pulse is inserted in the video data output of bands 1 through 4. Figure 3-1 shows the location of the calibration within the Major Frame.

The CALIBRATE segment starts 42.8 ± 2 ms after LINE START CODE and continues 10.2 ± 2 milliseconds. On alternate major frames (sweeps of the scanner) CALIBRATE segment is replaced with a DC Restore segment. The DC Restore is 20 ± 2 milliseconds of zero level inserted in band 4 only. The DC Restore starts 43.3 ± 2 milliseconds after the LINE START CODE.

- STARTS AERUPTLY AT ANY WORD BOUNDARY WHEN MIDSCAN IS ENABLED
- CONSISTS OF 100 WORDS OF BLACK (LOW INTENSITY LEVEL) FOLLOWED BY 100 WORDS OF WHITE (HIGH INTENSITY LEVEL).
- MNFS AND MNFS ARE NOT PRE-EMPTED BY MIDSCAN OR ENDSCAN CODE ALTHOUGH THEIR TIME SLOT IS COUNTED IN DETERMINING THE TOTAL CODE LENGTH OF 200 WORDS.

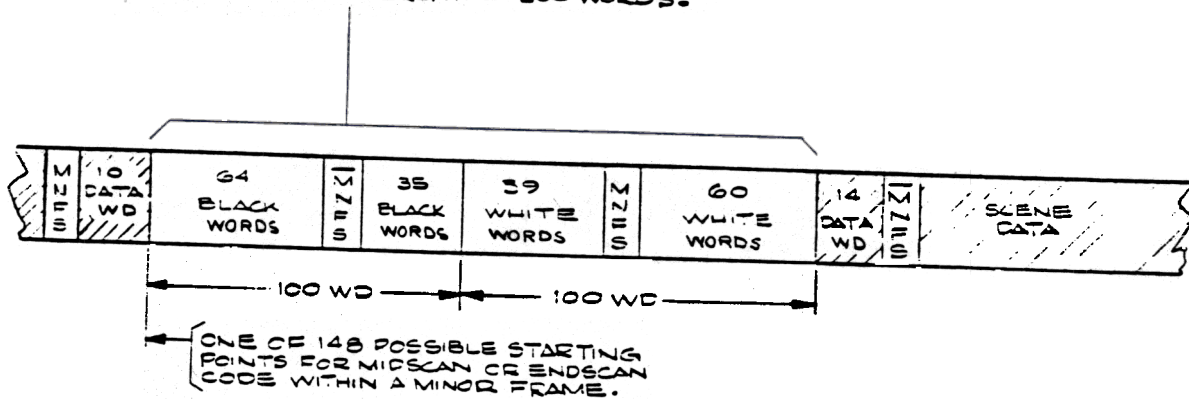

Figure 3-4. MSS MID/END Scan Code Format

SECTION 4

ACRONYMS AND ABBREVIATIONS

ACS	Attitude Control System
	Analog to Digital
	Band-to-Band Registration
	Bus Coupling Unit
	Binary Coded Decimal
	Band 6 Data
	Band-Interleaved-by-line
	Band-Interleaved-by-Pixel
	Band Sequential
CCSA	Computer Address
CC	Computer Command Slot
	Computer Compatible Tape
C&DH	Command and Data Handling
	Cooled Focal Plane Assembly (Array)
CMD	Command
CPN	Control Point Neighborhoods
	Calibration/Restore Shutter
CSF	Control and Simulation Facility
CU	Central Unit
DBMS	Data Base Management System
DC	Direct Current

Decom	Decommutator
Demux	Demultiplexer
Demod	Demodulator
	Data Format Control Book
	Data Management System
DOMSAT	Domestic Communication Satellite
	Digital Processing Unit
DRRTS	Data Receive Record Transmit Subsystem
	Downlink Synchronization Module
	Data Extraction and Formatting
EDC	EROS Data Center
EDIPS	EDC Digital Image Processing System
ELC	End of Line Code
	Earth Resources Observation System
ERTS	Earth Resources Technology Satellite
EU	Expander Unit
FAIRS	Full Aperture Infrared Source
FM	Flight Model
FOV	Field-of-View
FPA	Focal Plane Array
FPDA	Focal Plane Detector Array
GECP	Geometric Correction
GDOP	Geometric-Dilution-of-Precision (the ratio of uncertainty in position of uncertainty in range measurements)

Greenwich Mean Time
Global Positioning System
Goddard Space Flight Center
GSTDN Ground Spaceflight Tracking Data Network
HDT High Density Magnetic Tape
HDT-A High Density Magnetic Tape - Archive Tape
HDT-P High Density Magnetic Tape - Product Tape
HDT-R High Density Magnetic Tape - Raw Data Tape
HDT-S High Density Magnetic Tape - White Sands Tape
HgCdTe Mercury Cadmium Telluride
HOM Horizontal Oblique Mercator
Horizontal Resampling
TLM Housekeeping Telemetry
Interface Control Document or Drawing
Instantaneous Field-of-View
Image Generation Facility
IGFOV Instantaneous Geometric FOV
IM Instrument Module
Indium Arsenide
Indium Antimonide
Inter-Record Gap
IRIG-A Inter-Range Instrumentation Group, standard time, format A
Light Emitting Diode
LFA Laminar Flow Array

	Left-Hand Circular
	Line Length Code
LS	Line Start
	Least Significant Bit
	Landsat-D
	Least Significant Word
MA	Multiple Access
	Mega Bits Per Second
MDB	Multiplex Data Bus
	Multiplexer-Demultiplexer (MUX-DEMUX)
M/F	Minor Frame
MMS	Multimission Modular Spacecraft
MNFS	Minor Frame Sync Code
Mod	Modulator
MSB	Most Significant Bit
MSS	Multispectral Scanner or Module Support Structure
MSW	Most Significant Word
MUX	Multiplexer
NASA	National Aeronautics and Space Administration
NASCOM	NASA Communications Network
NDS	Navigation Data Satellite
NETD	Noise Equivalent Temperature Difference
NRZ	Nonreturn to Zero (digital code)
NRZ-L	Non-Return to Zero Level

On Board Computer

ONS Operational Navigation Satellite

 Pulse Amplitude Modulation

PCD Payload Correction Data

 Pulse Code Modulation

 Power Distribution Unit

 Pre-Flight Disconnect

PM Propulsion Module

 Pre-Modulation Processor

PN Pseudo Noise

$\overline{\text{PN}}$ Inverse Pseudo Noise

 Pre-Processor Modulator

 Pulses Per Second

POCC Payload Operations Control Center

PROM Program Read Only Memory

 Propulsion (Subsystem)

PS Polar Stereographic

PSDO Parallel/Serial Data Output

PSK Phase Shift Keyed

 Quick Look

 Random Access Memory

RDCP Radiometric Correction

RF Radio Frequency

 Right Hand Circular

Remote Interface Unit
Receiver/Processor Assembly (GPS)
RT Real Time
Scan Angle Monitor
SBRC Santa Barbara Research Center
Spacecraft
SC&CU Signal Conditioning & Control Unit
SiFPA Silicon Focal Plane Array (Assembly)
SiFPA Silicon Focal Plane Array (Assembly)
Scan Line Corrector
Scan Line Sync
SMA Scan Mirror Assembly
SMC Scan Mirror Control
SME Scan Mirror Electronics
SMM Solar Maximum Mission
SOM Space Oblique Mercator
SQPSK Staggered Quadriphase Phase Shift Keyed
SSA S-Band Single Access
STACC Standard Telemetry and Command Components
STDN Spaceflight Tracking Data Network
STINT STACC Interface Unit
SUBCOM Subcommutation
TA Telemetry Address
TBS To Be Supplied

TC	Time Code
TCG	Time Code Generator
	Tracking and Data Relay Satellite
TDRSS	Tracking and Data Relay Satellite System
	Transportable Ground Station
	Telemetry
TM	Thematic Mapper
TWTA	Traveling Wave Tube Amplifier
UQPSK	Unbalanced Quadrature Phase Shift Keyed
	Universal Transverse Mercator
	Vertical Resampling
WB	Wideband
	Wide Band Video Tape
WBVTR	Wideband Video Tape Recorder
WCS	Wideband Communications Subsystem

SECTION 5

REFERENCES AND SOURCES

1. Landsat-D Mission System Proposal; Proposal No. C-77285, Parts 1 and 2; GE, 19 October 1977.
2. Landsat-D Support Instrumentation Requirements Document (SIRD); NASA, January 1979.
3. Specification for the Landsat-D System, Revision C; GSFC-430-D-100; NASA/GSFC, August 1978.



***SPACE
SYSTEMS
DIVISION***

Headquarters: Valley Forge, PA Huntsville, AL Lanham, MD
 Houston, TX Sunnyvale, CA Beltsville, MD
 Palmdale, CA Bedford, MA Washington, D.C. Area