

Safeguarding Equipment and Protecting Workers from Amputations



Small Business Safety and Health Management Series

U.S. Department of Labor
Occupational Safety and Health Administration

OSHA 3170
2001

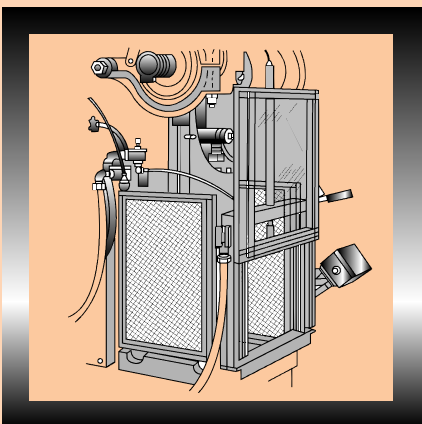
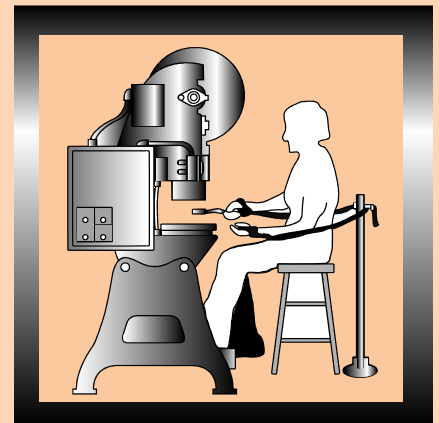
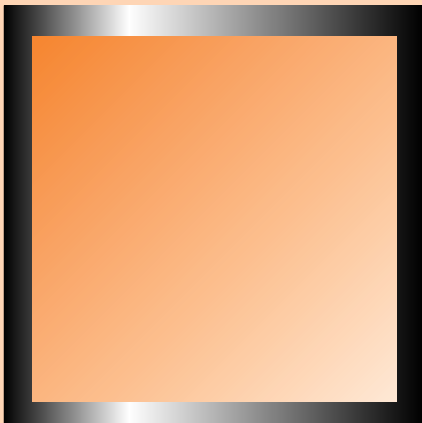
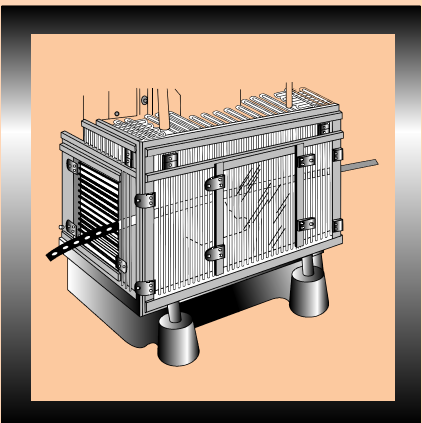
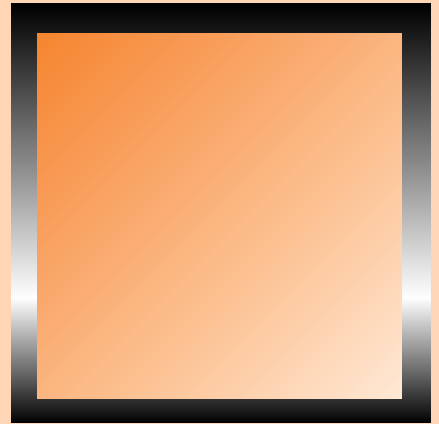
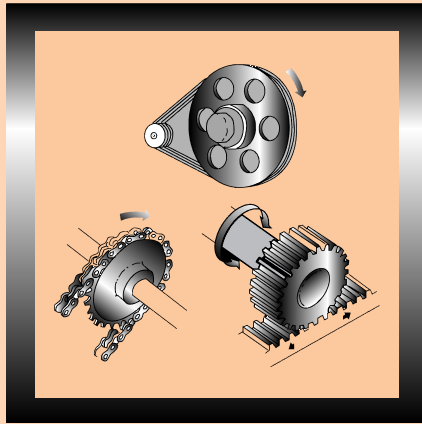

This publication provides a generic, non-exhaustive overview of a particular standards-related topic. This publication does not itself alter or determine compliance responsibilities, which are set forth in OSHA standards themselves, and the *Occupational Safety and Health Act*. Moreover, because interpretations and enforcement policy may change over time, for additional guidance on OSHA compliance requirements, the reader should consult current administrative interpretations and decisions by the Occupational Safety and Health Review Commission and the courts.

Material contained in this publication is in the public domain and may be reproduced, fully or partially, without the permission of the Federal Government. Source credit is requested but not required.

This information will be made available to sensory impaired individuals upon request. Voice Phone: (202) 693-1999; teletypewriter (TTY) number: 1-877-889-5627.

Safeguarding Equipment and Protecting Workers from Amputations



Small Business Safety and Health Management Series

U.S. Department of Labor
Occupational Safety and Health Administration

OSHA 3170
2001

Introduction	1
Who Should Read This Guide?	1
Why Is This Guide Important?	1
How Can This Guide Help Me?	1
What Does This Guide Cover?	1
Are There Specific Standards and Requirements for Safeguarding Machinery?	1
Are There Other Requirements I Need to Know About?	1
What Types of Hazards Do I Need to Look for?	2
How Can I Control Potential Hazards?	2
 Recognizing Amputation Hazards	 3
What Types of Mechanical Components Are Hazardous?	3
What Types of Mechanical Motions Are Hazardous?	3
What Are the Hazardous Activities Involving Stationary Machines?	5
 Controlling Amputation Hazards	 6
What Are Some Basic Safeguarding Methods?	6
What Are Guards?	6
What Are Some Safeguarding Devices I Can Use?	8
Are There Other Ways to Safeguard Machines?	13
What Is Guarding by Location?	13
What Is Safeguarding by Feeding Methods?	13
Can Workers Use Hand-Feeding Tools?	14
Are Foot Controls Another Option?	14
What About Controls for Machines with Clutches?	14
Do I Need to Safeguard Machinery?	15
What Administrative Issues Must Be Considered When Safeguarding Machinery?	15
Are There Standards for Machine Safeguards?	16
 Identifying Hazards for Specific Types of Machinery	 17
What Are Mechanical Power Presses and Their Hazards?	17
How Do I Safeguard My Mechanical Power Presses?	18
What Work Practices and Administrative Controls Should I Use?	19
What Other Controls Pertain to Mechanical Power Press Die Set-Up and Maintenance?	20
What Type of Training Should I Provide?	20
What Work Practices Should I Use?	20
What Do I Need to Know About Power Press Brakes?	20
What Are the Hazards Associated with Power Press Brakes?	21
How Can I Safeguard Power Press Brakes?	21
What About Work Practices and Administrative Controls for Power Press Brakes?	22
What Are the Hazards Associated with Conveyors?	23
What Do I Need to Know About Conveyors?	23
What Types of Engineering Controls Should I Use for Conveyors?	24
What Work Practices and Administrative Controls Do I Need to Use?	26
What Are the Hazards from Printing Presses?	27
What Types of Controls Can I Use to Safeguard Printing Presses?	28
What Are the Work Practices and Administrative Controls I Can Use for Printing Presses?	29
What Are the Hazards from Roll-Forming and Roll-Bending Machines?	29
What Engineering Controls Should I Use to Protect Employees?	30

Are There Work Practice and Administrative Controls I Can Employ for These Machines?	31
What Are Shearing Machines and Their Hazards?	32
What Controls Can I Use on Shearing Machines?	33
Are There Other Controls I Can Implement?	34
What Are the Hazards Associated with Food Slicers?	35
What Types of Controls Can I Use to Safeguard Slicers?	35
What Are the Hazards of Using Meat Grinders?	36
What Are the Engineering and Other Controls I Can Use to Prevent These Hazards?	37
How Do Meat-Cutting Band Saws Pose Hazards?	38
What Safeguards Can I Use?	39
What About Drill Presses and Related Hazards?	40
What Are Some Methods for Safeguarding Drill Presses?	41
What About Milling Machines and Related Hazards?	41
What Are Some Milling Machine Safeguarding Methods?	42
What Are the Hazards of Working with Grinding Machines?	43
How Can I Safeguard Grinding Machines?	44
What Are the Hazards from Slitters?	45
What Are Some Ways to Safeguard Slitter Machines?	46
Other Sources of OSHA Assistance	48
Safety and Health Program Guidelines	48
State Programs	48
Consultation Services	48
Voluntary Protection Program (VPP)	49
Strategic Partnership Program	49
Training and Education	49
Electronic Information	49
OSHA Publications	50
Emergencies, Complaints, and Further Assistance	50
References	51
Appendices	
A. Amputation Hazards Not Covered in This Guide	53
B. Amputation Hazards Associated with Other Equipment and Activities	54
C. OSHA Office Directory	55
List of Tables	
Table 1. Commonly Used Machine Guards	7
Table 2. Types of Safeguarding Devices	9
List of Figures	
Figure 1. Rotating Motion	3
Figure 2. Reciprocating Motion	3
Figure 3. Transversing Motion	4
Figure 4. Cutting Action	4
Figure 5. Punching Action	4

Figure 6. Shearing Action	5
Figure 7. Bending Action	5
Figure 8. Inrunning Nip Points	5
Figure 9. Fixed Guard on a Power Press	6
Figure 10. Power Press with Adjustable Barrier Guard	6
Figure 11. Self-Adjusting Guard on a Radial Saw	8
Figure 12. Interlocked Guard on Roll Make-up Machine	8
Figure 13. Pullback Device on a Power Press	8
Figure 14. Restraint Device on Power Press	12
Figure 15. Presence Sensing Device on a Power Press	12
Figure 16. Safety Tripod on a Rubber Mill	12
Figure 17. Two-Hand Control	12
Figure 18. Power Press with Gate	13
Figure 19. Power Press with Plunger Feed	13
Figure 20. Shuttle Ejection Mechanism	14
Figure 21. Typical Hand Feeding Tools	14
Figure 22. Properly Guarded Foot Control	14
Figure 23. Part Revolution Mechanical Power Press with Two-Hand Control.....	17
Figure 24. Hand Feeding Tools Used in Conjunction with Pullbacks on a Power Press	19
Figure 25. Power Press Brake Bending Metal	21
Figure 26. Two Person Power Press Brake Operation with Pullbacks	22
Figure 27. Belt Conveyor	24
Figure 28. Screw Conveyor	24
Figure 29. Chain Driven Live Roller Conveyor	24
Figure 30. Slat Conveyor	24
Figure 31. Roll-to-Roll Offset Printing Press	27
Figure 32. Sheet-Fed Offset Printing Press	27
Figure 33. Roll-Forming Machine	30
Figure 34. Infeed Area of a Roll-Forming Machine	30
Figure 35. Hydraulic Alligator Shear	32
Figure 36. Power Squaring Shear	32
Figure 37. Meat Slicer	35
Figure 38. Stainless Steel Meat Grinder	36
Figure 39. Stainless Steel Meat-Cutting Band Saw	38
Figure 40. Drill Press with Transparent Drill Shield	40
Figure 41. Bed Mill	42
Figure 42. Horizontal Surface Grinder	44
Figure 43. Paper Slitter	46

Who Should Read this Guide?

Anyone responsible for the use and care of stationary machinery—employers, employees, safety professionals, and industrial hygienists—should read this publication. This guide can help you, the small business employer, identify and manage common amputation hazards associated with operating and using stationary equipment.

Why Is This Guide Important?

Amputations are among the most severe and disabling workplace injuries. They are widespread and involve various activities and equipment. (The U.S. Bureau of Labor Statistics 1996 annual survey indicated that there were approximately 10,000 amputations for all industry sectors.) About one-half of all workplace amputations occur in the manufacturing sector and the rest occur across the construction, agriculture, wholesale and retail trade, and service industries. These injuries result from using stationary machines such as saws, presses, conveyors, and bending, rolling, or shaping machines as well as from powered and non-powered hand tools, forklifts, doors, and trash compactors; and during materials handling activities.

How Can This Guide Help Me?

As an employer, this information will help you protect your employees. It will help you and your employees recognize, manage, and control the potential hazards of the stationary machines in your workplace. The information does not cover all equipment associated with amputation or amputation hazards in maritime and agriculture operations.

What Does This Guide Cover?

The first two sections of the document, **Recognizing Amputation Hazards** and **Controlling Amputation Hazards**, look at sources of amputations and how to safeguard machinery. The section on Specific Machinery, Hazards, and Safeguards deals with the hazards and safeguarding methods for the equipment most frequently associated with workplace amputations: mechanical power presses, power press brakes, shears, food slicers, meat grinders, meat-cutting band saws, drill presses, milling machines, grinding machines, and slitting

machines. In addition, the references and appendices identify applicable OSHA standards, what amputation hazards are not covered, and other types of equipment associated with amputations.

Are There Specific Standards and Requirements for Safeguarding Machinery?

Yes. Although this guide recommends work practices and ways to safeguard machinery, there are legal requirements in OSHA standards that you need to know and comply with. These include, for example, OSHA General Industry Standards, *Title 29 of the Code of Federal Regulations (CFR)*, Part 1910 and the Construction Industry Standards in 29 *CFR* 1926. Specifically, Subpart O of the General Industry Standards and Subpart I of the Construction Standards outline the machine guarding requirements for much of the equipment presented in this publication. Consult these standards directly to ensure full compliance with the provisions. States with OSHA - approved plans have equivalent standards. These and other OSHA standards and documents are available online at www.osha.gov

Are There Other Requirements I Need to Know About?

The American National Standards Institute (ANSI) publishes voluntary consensus standards on the safe care and use of specific machinery. ANSI standards also may give you guidance for complying with OSHA performance-based standards, such as 29 *CFR* 1910.212-*General Requirements for all machines*. ANSI standards are sometimes incorporated into OSHA regulations, and in these cases, employers are accountable for complying with the specific version referenced. OSHA generally recommends, however, that employers use the most recent version of ANSI standards.

2 Introduction

Under the Fair Labor Standards Act (FLSA), the Secretary of Labor has designated certain non-farm jobs as particularly hazardous for employees younger than 18. Generally, these workers are prohibited from operating:

- band saws,
- circular saws,
- guillotine shears,
- punching and shearing machines,
- meatpacking or meat-processing machines, and certain power-driven machines:
 - paper products machines,
 - woodworking machines,
 - metal forming machines, and
 - meat slicers.

What Types of Hazards Do I Need to Look for?

To prevent worker amputations, you and your employees must be able to recognize the contributing factors, such as the mechanical components of machinery, the mechanical motion that occurs at or near these components, and the specific worker activities performed with the mechanical operation.

How Can I Control Potential Hazards?

Machine safeguarding is the primary way to control amputation hazards associated with stationary machinery. Work practices, employee training, and administrative controls also play an important role in preventing and controlling these workplace hazards. (See OSHA's 1989 Safety and Health Program Management Guidelines and OSHA standards in the References section.)

Anyone working around stationary equipment should be able to identify potential amputation hazards. Understanding the mechanical components of machinery, the mechanical motion that occurs at or near these components, and specific worker activities performed in conjunction with machinery operation will help workers avoid injury.

What Types of Mechanical Components Are Hazardous?

Three types of mechanical components present amputation hazards:

- **Point of Operation** is the area of the machine where the machine performs work. Mechanical actions that occur at the point of operation, including cutting, shaping, boring, and forming.
- **Power-Transmission Apparatuses** are all components of the mechanical system that transmit energy such as flywheels, pulleys, belts, chains, couplings, connecting rods, spindles, cams, and gears.
- **Other Moving Parts** are the parts of the machine that move while the machine is operating, such as reciprocating, rotating, and transverse moving parts as well as lead mechanisms and auxiliary parts of the machine.

What Types of Mechanical Motions Are Hazardous?

All mechanical motion is potentially hazardous. Here are the basic types of hazardous mechanical motions:

- **Rotating Motion** (Figure 1) is circular motion such as action generated by rotating collars, couplings, cams, clutches, flywheels, shaft ends, and spindles, that may grip clothing or otherwise force a body part into a dangerous location. Projections such as screws or burrs on the rotating part increase the hazard potential.

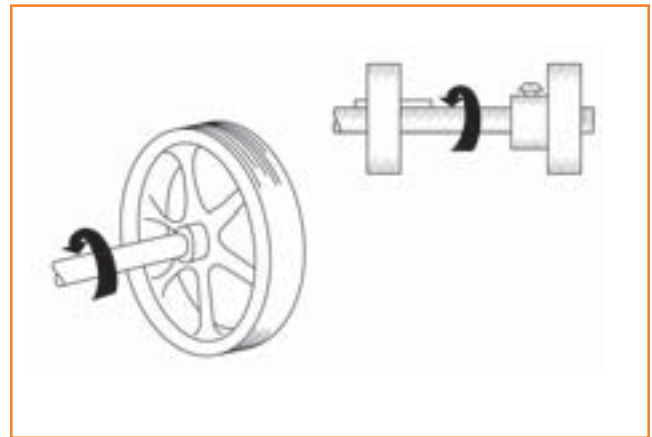

Figure 1. Rotating Motion

- **Reciprocating Motion** (Figure 2) is back-and-forth or up-and-down motion that may strike or entrap a worker between a moving part and a fixed object.

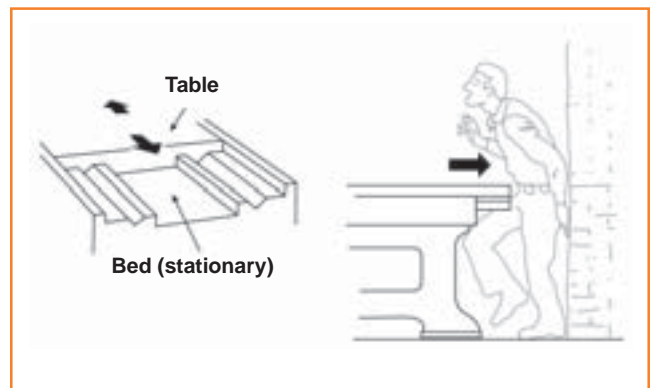

Figure 2. Reciprocating Motion

4 Recognizing Amputation Hazards

- **Transversing Motion** (Figure 3) is motion in a straight, continuous line that may strike or catch a worker in a pinch or shear point created by the moving part and a fixed object.

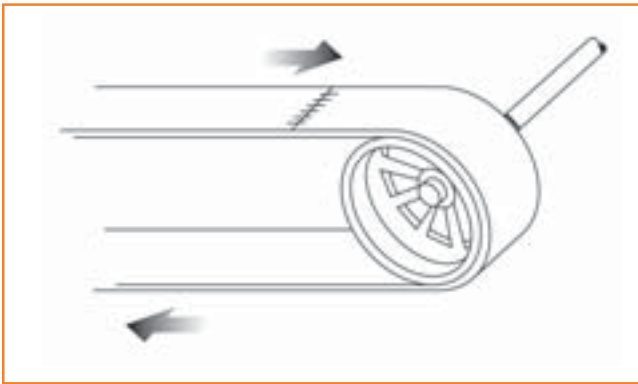

Figure 3. Transversing Motion

- **Cutting Action** (Figure 4) occurs by sawing, boring and drilling, milling, and slicing or slitting machinery.

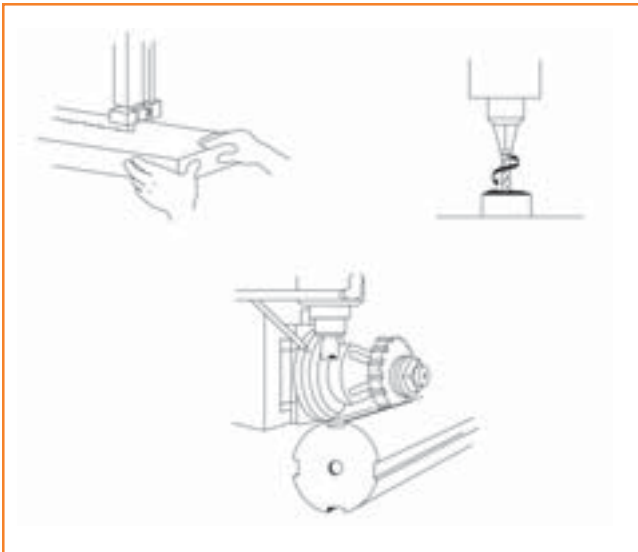

Figure 4. Cutting Action

- **Punching Action** (Figure 5) begins when power causes the machine to hit a slide (ram) to stamp or blank metal or other material. The hazard occurs at the point of operation where the worker inserts, holds, or withdraws the stock by hand.

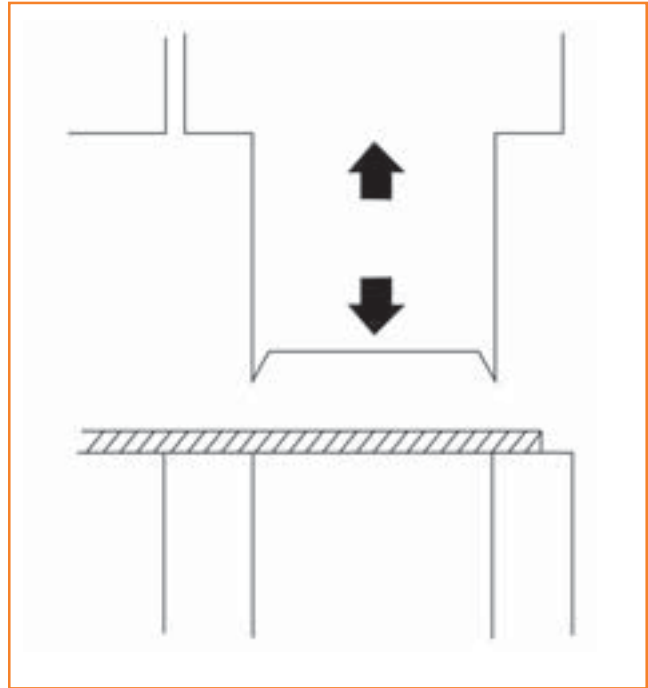

Figure 5. Punching Action

- **Shearing Action** (Figure 6) is powered slide or knife movement used to trim or shear metal or other materials generates the motion. The hazard occurs at the point of operation where the worker inserts, holds, or withdraws the stock by hand.

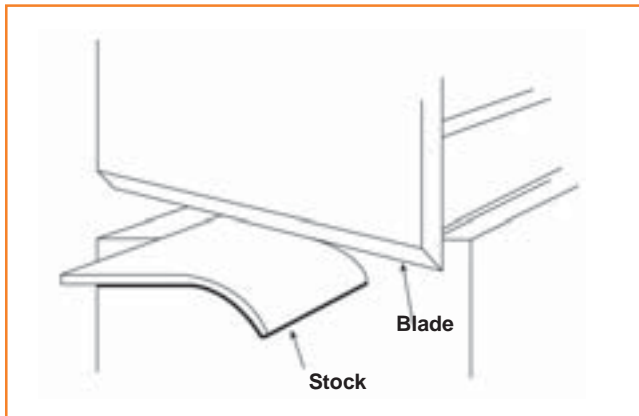

Figure 6. Shearing Action

- **Bending Action** (Figure 7) is power applied to a slide to draw or stamp metal or other materials generates the motion. The hazard occurs at the point of operation where the worker inserts, holds, or withdraws the stock by hand.

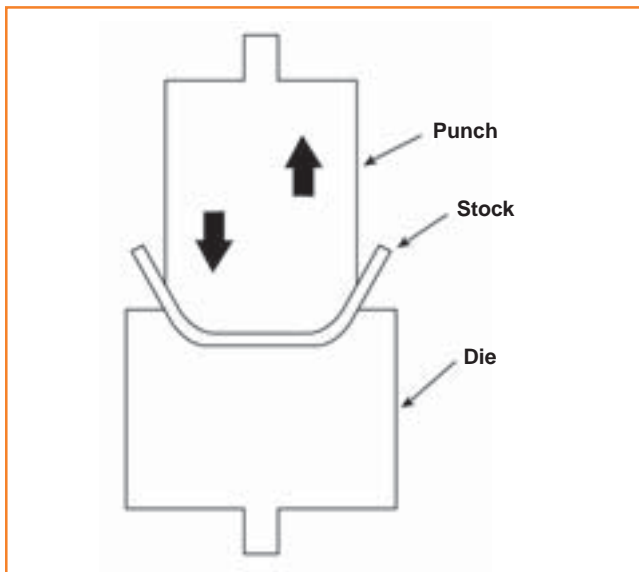

Figure 7. Bending Action

- **In-Running Nip Points** (Figure 8), also known as “pinch points,” develop when two parts move together and at least one moves in rotary or circular motion. In-running nip points occur whenever machine parts move toward each other or when one part moves past a stationary object.

Typical nip points include gears, rollers, belt drives, and pulleys.

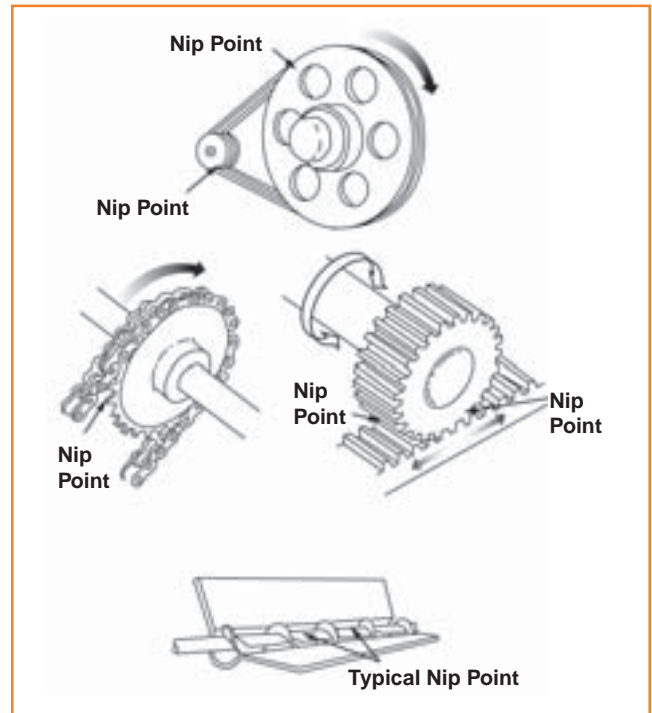

Figure 8. In-running Nip Points

What Are the Hazardous Activities Involving Stationary Machines?

Workers operating stationary machinery perform various activities that present potential amputation hazards:

- Machine set-up/threading/preparation,
- Normal operation,
- Clearing jams,
- Machine adjustments,
- Cleaning of machine,
- Lubricating of machine parts, and
- Scheduled and unscheduled maintenance.

When evaluating activities for potential amputation hazards, you should consider the entire operation, individual activities associated with the operation, and the potential for injury to workers nearby.

6 Controlling Amputation Hazards

Machine safeguarding is the primary means of controlling amputation hazards associated with stationary machinery during normal operations. In addition, work practices, employee training, and administrative controls play an important role in the prevention and control of workplace amputations.

OSHA requires adequate safeguards for all machines and equipment generating hazardous mechanical movement. OSHA's general industry and construction industry requirements for machine guarding are listed at the end of this chapter.

What Are Some Basic Safeguarding Methods?

Two basic methods are used to safeguard machines: guards and devices. Guards provide physical barriers that prevent access to danger areas. Devices function by interrupting the machine's operating cycle to prevent workers from reaching or entering the danger area while the machine is cycling. Both types of safeguards should be designed and installed to ensure worker protection.

Criteria for Machine Safeguarding

- Prevents worker contact with the hazard area during the operating cycle.
- Avoids creating additional hazards.
- Is secure, tamper-resistant, and durable.
- Avoids interfering with normal operation of the machine.
- Allows for safe lubrication and maintenance.

What Are Guards?

Guards are physical barriers that enclose dangerous machine parts and prevent worker contact with them. Guards must be secure and strong. Workers should not be able to bypass, remove, or tamper with guards. To prevent tampering, guards typically require a tool to unfasten and remove them. Guards should not create additional hazards such as pinch points or shear points between guards and other machine parts. Guards should not obstruct

the operator's view or prevent workers from doing a job. Metal bars, Plexiglass™, or similar guards are suitable. Guard openings should be small enough to prevent workers from accessing danger areas. (See Table 1 and Figures 9 through 12 for commonly used machine guards.)

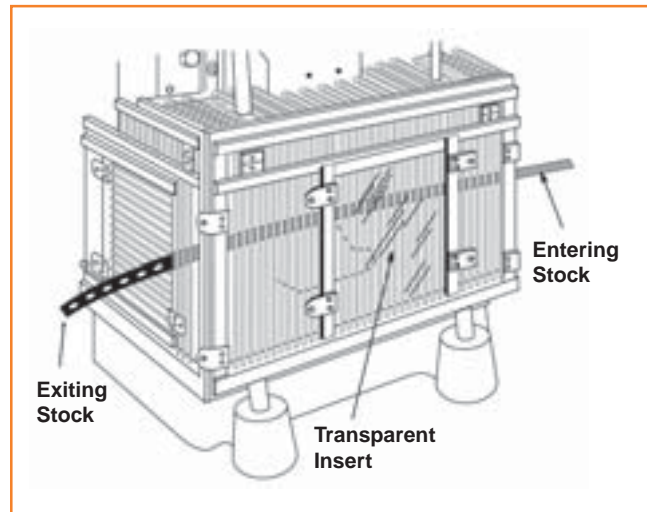

Figure 9. Fixed Guard on a Power Press

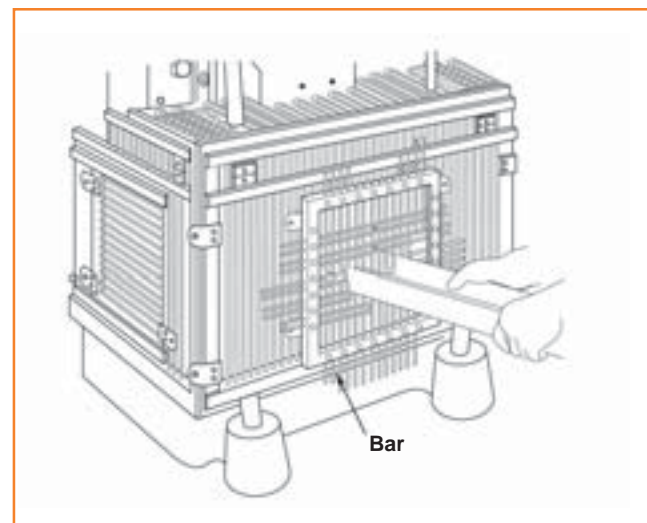

Figure 10. Power Press with Adjustable Barrier Guard

Table 1. Commonly Used Machine Guards

Types of Machine Guards			
Type	Safeguarding Action	Advantages	Limitations
Fixed	Barrier that allows for stock feeding but does not permit operator to reach the danger area.	<ul style="list-style-type: none"> • Can be constructed to suit many applications. • Permanently encloses the point of operation or hazard area. • Provides protection against machine repeat. • Allows simple, in-plant construction, with minimal maintenance. 	<ul style="list-style-type: none"> • Sometimes not practical for changing production runs involving different size stock or feeding methods. • Machine adjustment and repair often require guard removal. • Other means of protecting maintenance personnel often required (lockout/tagout).
Adjustable	Barrier that adjusts for a variety of production operations.	<ul style="list-style-type: none"> • Can be constructed to suit many applications. • Can be adjusted to admit varying stock sizes. 	<ul style="list-style-type: none"> • May require frequent maintenance or adjustment. • Operator may make guard ineffective.
Self-Adjusting	Barrier that moves according to the size of the stock entering point of operation. Guard is in place when machine is at rest and pushes away when stock enters the point of operation.	<ul style="list-style-type: none"> • Off-the-shelf guards are often commercially available. 	<ul style="list-style-type: none"> • Does not provide maximum protection. • May require frequent maintenance and adjustment.
Interlocking	Shuts off or disengages power and prevents machine start-up when guard is open. Should allow for inching of machine. Replacing the guard should not automatically restart the machine.	<ul style="list-style-type: none"> • Allows access for machine set-up, adjustment, or jam removal without time-consuming removal of fixed guards when used with hand tools or safety blocks. 	<ul style="list-style-type: none"> • May require periodic maintenance or adjustment. • Movable sections cannot be used for manual feeding. • Some designs may be easy to defeat.

8 Controlling Amputation Hazards

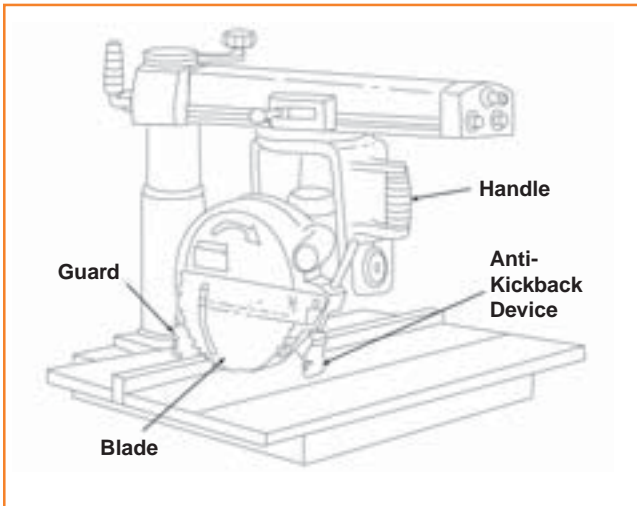

Figure 11. Self-Adjusting Guard on a Radial Saw

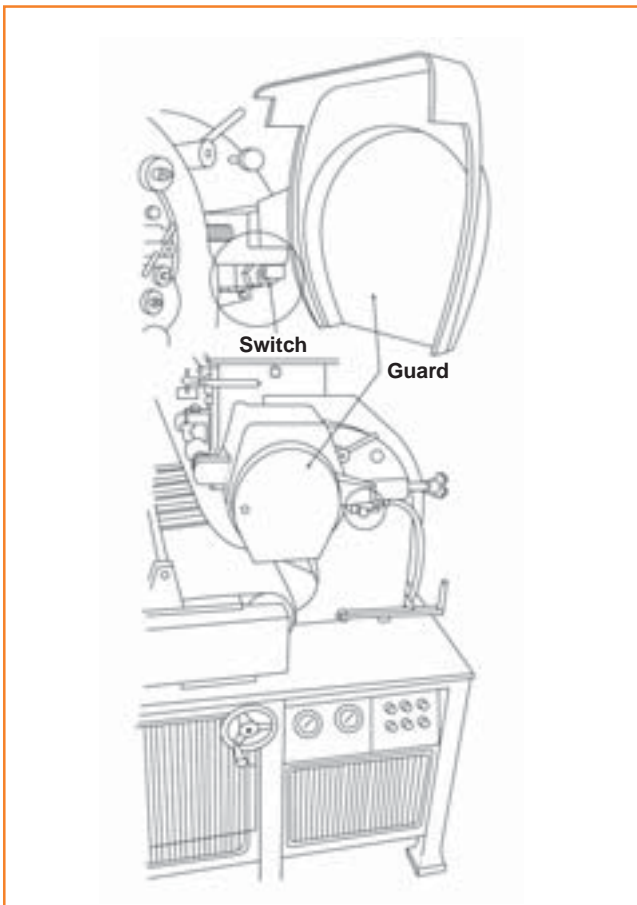

Figure 12. Interlocked Guard on Roll Make-up Machine

What Are Some Safeguarding Devices I Can Use?

Safeguarding devices typically help prevent operator contact with the point of operation. They may be used in place of guards or as a supplemental control when guarding alone does not adequately enclose the hazard. Safeguarding devices either (1) interrupt the normal cycle of the machine if the operator's hands are at the point of operation, (2) prevent the operator from reaching into the point of operation, or (3) withdraw the operator's hands if they are located in or near the point of operation when the machine cycles. (See Table 2 and Figures 13 through 18 for the types of safeguarding devices.)

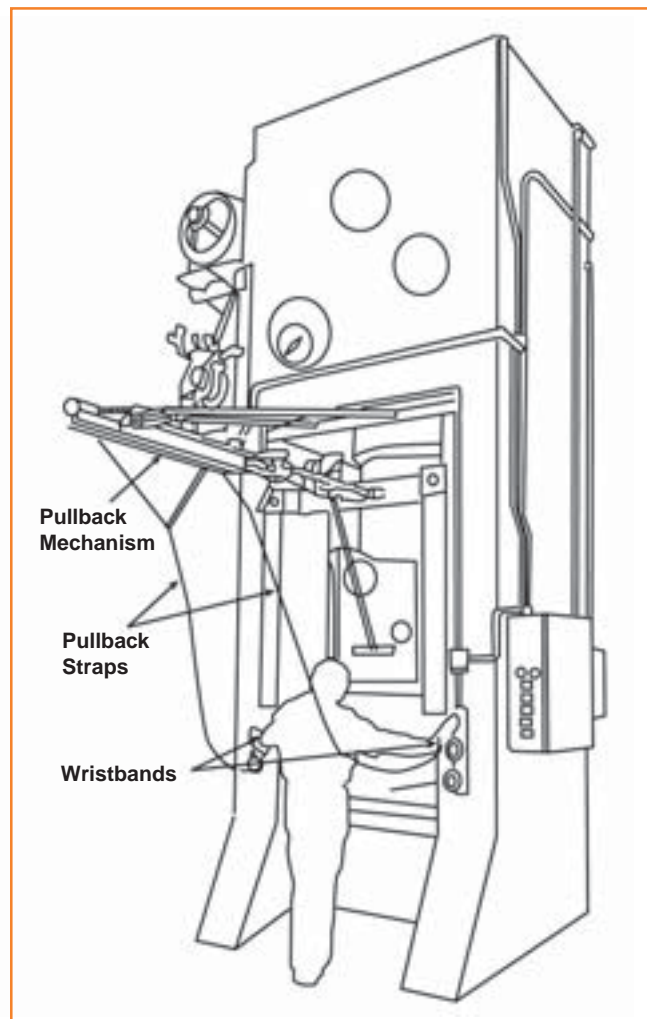

Figure 13. Pullback Device on a Power Press

Table 2. Types of Safeguarding Devices

Types of Machine Devices			
Type	Method of Safeguarding	Advantages	Limitations
Pullback Devices	Cords connected to operator’s wrists and linked mechanically to the machine automatically withdraw the hands from the point of operation during the machine cycle.	<ul style="list-style-type: none"> • Allows the hands to enter the point of operation for feeding and removal. • Provides protection even in the event of mechanical repeat. 	<ul style="list-style-type: none"> • Close supervision ensures proper use and adjustment. Must be inspected prior to each operator change or machine set-up. • Limits operator’s movement and may obstruct their work space. • Operator may easily make device ineffective by not adjusting the device properly.
Restraint Devices	Wrists are connected by cords and secured to a fixed anchor point which limit operator’s hands from reaching the point of operation at any time.	<ul style="list-style-type: none"> • Simple, few moving parts; requires little maintenance. • Operator cannot reach into the danger area. • Little risk of mechanical failure; provides protection even in the event of mechanical repeat. 	<ul style="list-style-type: none"> • Close supervision required to ensure proper use and adjustment. Must be inspected prior to each operator change or machine set-up. • Operator must use hand tools to enter the point of operation. • Limits the movement of the operator; may obstruct work space around operator. • Operator may easily make device ineffective by disconnecting the device.

10 Controlling Amputation Hazards

Table 2. Types of Safeguarding Devices (Continued)

Types of Machine Devices			
Type	Method of Safeguarding	Advantages	Limitations
Presence-Sensing Devices	Interlock into the machine's control system to stop operation when the sensing field (photoelectric, radio frequency, or electromagnetic) is disturbed.	<ul style="list-style-type: none"> • Adjusts to fit different stock sizes. • Allows access to load and unload the machine. • Allows access to the guarded area for maintenance and set-up activities. 	<ul style="list-style-type: none"> • Restricted to machines that stop operating cycle before operator can reach into danger area (e.g., machines with partial revolution clutches or hydraulic machines). • Must be carefully maintained and adjusted. • Does not protect operator in the event of a mechanical failure. • Operator may make device ineffective.
Presence-Sensing Mats	Interlock into machine's control system to stop operation when a predetermined weight is applied to the mat. A manual reset switch must be located outside the protected zone.	<ul style="list-style-type: none"> • Full visibility and access to the work area. • Install as a perimeter guard or over an entire area. • Configure for many applications. 	<ul style="list-style-type: none"> • Restricted to machines that stop operating cycle before operator can reach into danger area (e.g., machines with partial-revolution clutches or hydraulic machines). • Some chemicals can degrade the mats. • Does not protect operator during mechanical failures.
Safety Trip Controls (pressure-sensitive body bar, safety triprod, safety tripwire)	Stops machine when tripped.	<ul style="list-style-type: none"> • Simple to use. 	<ul style="list-style-type: none"> • Must be manually activated. • May be difficult to activate due to location. • Protects operator only. • May require a machine brake.

Table 2. Types of Safeguarding Devices (Continued)

Types of Machine Devices			
Type	Method of Safeguarding	Advantages	Limitations
Two-Hand Control	Requires concurrent and continued use of both hands, preventing them from entering the danger area.	<ul style="list-style-type: none"> • Operator’s hands are at a predetermined location. • Operator’s hands are free to pick up new parts after completion of first part of cycle. 	<ul style="list-style-type: none"> • Requires a partial cycle machine with a brake and anti-repeat feature. • Operator may make devices without anti-tiedown ineffective. • Protects the operator only.
Two-Hand Trip	Requires concurrent use of both hands, prevents them from being in danger area when machine cycle starts.	<ul style="list-style-type: none"> • Operator’s hands are at a predetermined location. • Can be adapted to multiple operations. • No obstruction to hand feeding. 	<ul style="list-style-type: none"> • Operator may make devices without anti-tiedown ineffective. • Protects the operator only. • Sometimes impractical because distance requirements may reduce production below acceptable level. • May require adjustment if tooling changes. • Requires anti-repeat feature.
Type “A” Gate (moveable barrier)	Applicable to mechanical power presses. Provides barrier between danger area and operator (or other workers) until completion of machine cycle.	<ul style="list-style-type: none"> • Prevents operator from reaching into danger area during machine cycle. • Provides protection from machine repeat. 	<ul style="list-style-type: none"> • May require frequent inspection and regular maintenance. • May interfere with operator’s ability to see work.
Type “B” Gate (moveable barrier)	Applicable to mechanical power presses and press brakes. Provides a barrier between danger area and operator (or other workers) during the downstroke.	<ul style="list-style-type: none"> • May increase production by allowing the operator to remove and feed the press on the upstroke. 	<ul style="list-style-type: none"> • Can only be used on machines with a part-revolution clutch or hydraulic machines. • May require frequent inspection and regular maintenance. • May interfere with the operator’s ability to see work.

12 Controlling Amputation Hazards

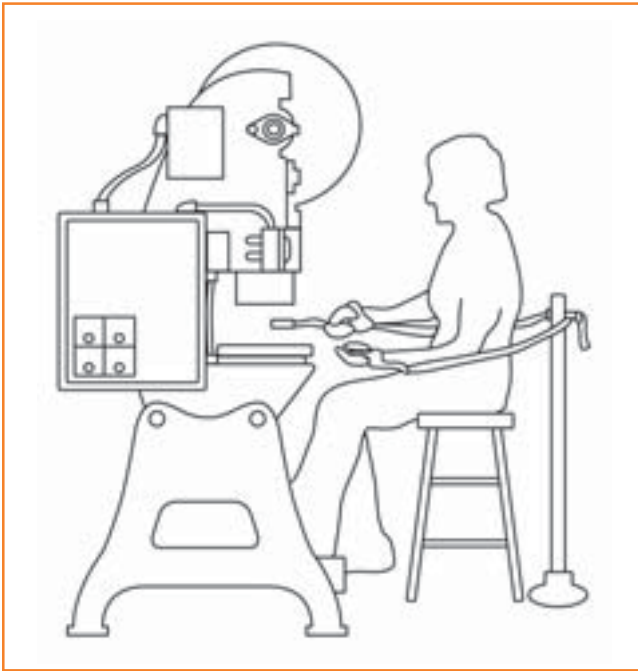

Figure 14. Restraint Device on Power Press

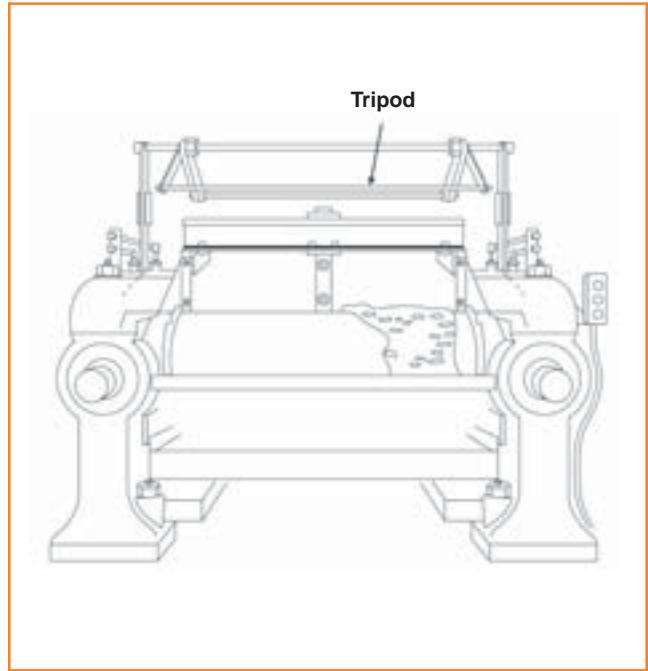

Figure 16. Safety Tripod on a Rubber Mill

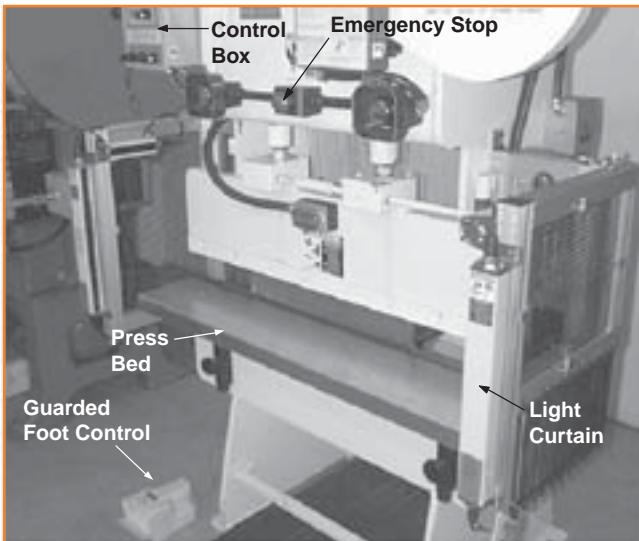

Figure 15. Presence Sensing Device on a Power Press

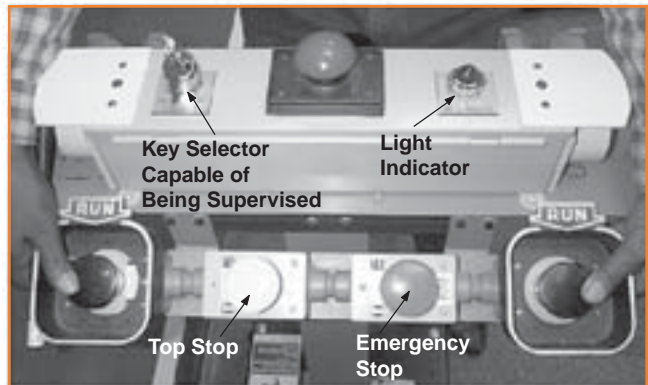

Figure 17. Two-Hand Control

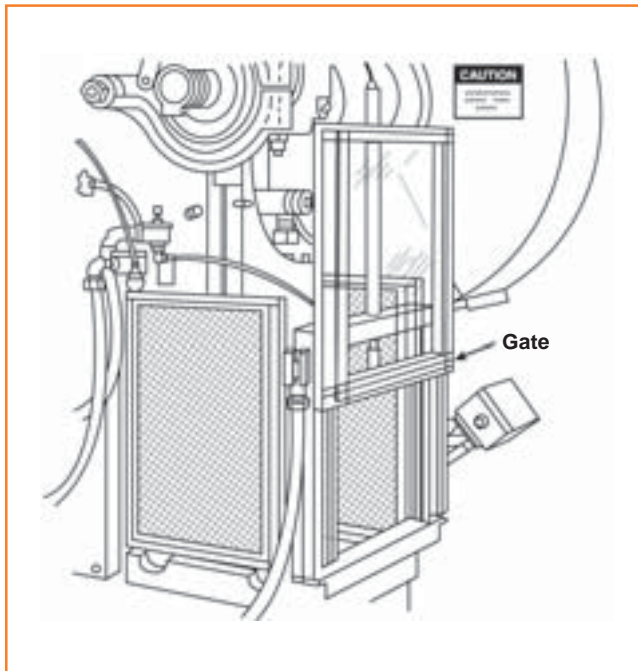

Figure 18. Power Press with Gate

Are There Other Ways to Safeguard Machines?

Yes, other methods for safeguarding machines include guarding by location or distance and by feeding methods that prevent operator access to the point of operation.

What Is Guarding by Location?

Safeguarding by location involves positioning or designing a machine so that the hazardous parts are away from areas where employees work or walk, or alternatively, installing enclosure walls or fences that restrict access to machines.

What Is Safeguarding by Feeding Methods?

The feeding process can be safeguarded by distance if the operators maintain a safe distance between their hands and the point of operation. For instance, if the stock is several feet long and only one end of the stock is being worked on, the operator may be able to hold the opposite end while performing the work. Safeguarding by distance is

sometimes used during power press brake operations to ensure its effectiveness. This method of safeguarding requires close supervision and training.

Automatic and semiautomatic feeding and ejection methods can protect the worker by minimizing or eliminating direct contact with machinery. These methods typically require frequent maintenance, however, and are only protective for normal machine operation.

Examples of semiautomatic feeding methods include gravity feeds, where the part slides down a chute into the point of operation and magazine feeding, where the worker places the part in a magazine which is then fed into the point of operation. Automatic and semiautomatic ejection methods include pneumatic (jet of air), magnetic, mechanical (such as an arm), or vacuum. Figures 19 and 20 illustrate different types of automatic feeding and ejecting methods.

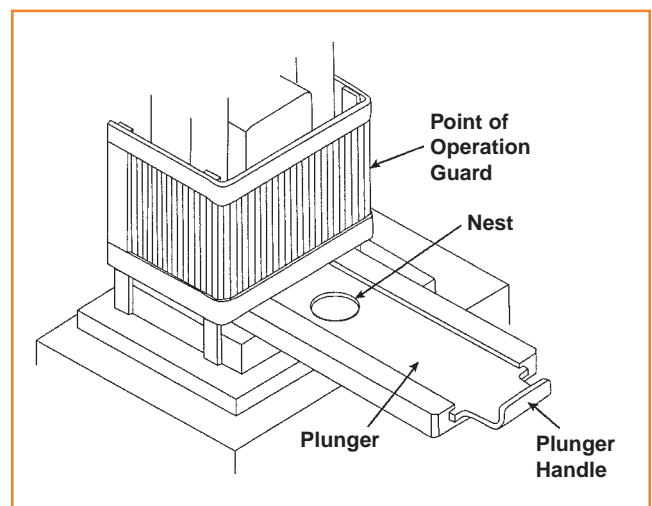

Figure 19. Power Press with Plunger Feed

14 Controlling Amputation Hazards

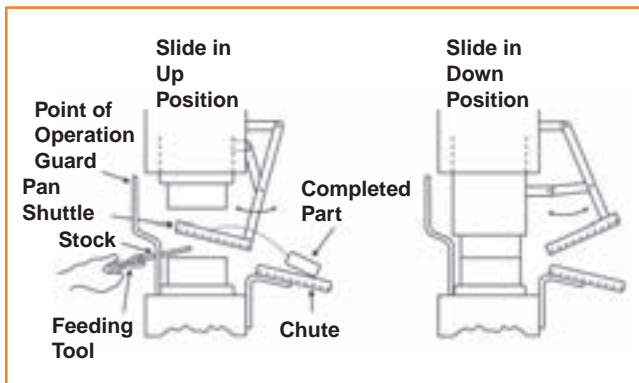

Figure 20. Shuttle Ejection Mechanism

Can Workers Use Hand-Feeding Tools?

Operators can use tools to feed work pieces into equipment to keep their hands away from the point of operation, but this should be done only in conjunction with the guards and devices described previously. Using hand tools requires close supervision to ensure that the operator does not bypass their use to increase production. Tools should be stored near the operation to encourage their use. To prevent repetitive trauma disorders, hand-feeding tools should be ergonomically designed for the specific task being performed. (Figure 21 shows typical hand-feeding tools.)

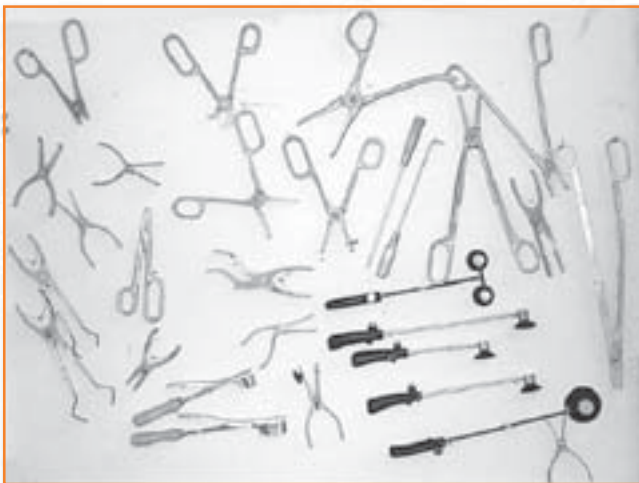

Figure 21. Typical Hand Feeding Tools

Are Foot Controls Another Option?

Foot controls are not safeguards because they do not keep the operator's hands out of the danger area. If you use them, they will need some type of guard or device, such as barriers or pullouts with interlocks capable of controlling the start up of the machine cycle. Using foot controls may increase productivity, but the freedom of hand movement allowed while the machine is operating increases the risk of a point of operation injury. Foot controls must be guarded to prevent accidental activation by another worker or by falling material and not allow continuous cycling. They work best when the operator is in a sitting position. Always avoid the hazard of riding the pedal (keeping the foot on the pedal while not actively depressing it.) (See properly guarded and positioned foot control in Figure 22.)



Figure 22. Properly Guarded Foot Control

What About Controls for Machines with Clutches?

Certain machines can be categorized based on the type of clutch they use—full-revolution or part-revolution. Differing modes of operation for these two clutches determine the type of guarding that can be used.

Once activated, full-revolution clutches complete a full cycle of the slide (lowering and raising of the slide) and cannot be disengaged until the cycle is complete. So, presence-sensing devices may not work and a worker must maintain a safe distance when using two-hand trips. Machines incorporating full-revolution clutches, such as power presses, must also incorporate a single-stroke device and anti-repeat feature.

The part-revolution clutch can be disengaged at any time during the cycle to stop the cycle before it completes the down stroke. For example, part-revolution presses can be equipped with presence-sensing devices, but full-revolution presses cannot. Likewise, hydraulic presses can be stopped at any point in the cycle, and their safeguarding is similar to guarding for part-revolution clutch presses.

Do I Need to Safeguard Machinery?

You are responsible for safeguarding machines and should consider this need when purchasing machinery. Most new machinery is available with safeguards installed by the manufacturer, but used equipment may not be.

In cases where machinery has no safeguards, you can purchase safeguards from the original machine manufacturer or an after-market manufacturer. You can also build and install the safeguards in-house. Safeguarding equipment should be designed and installed only by technically qualified professionals. In addition, the original equipment manufacturer should review the safeguard design to ensure that it will protect employees without interfering with the operation of the machine or creating additional hazards.

Regardless of the source of safeguards, the guards and devices you use should be compatible with a machine's operation and designed to ensure safe operator use. The type of operation, size, and shape of stock; method of feeding; physical layout of the work area; and production requirements all affect the selection of safeguards. Also, safeguards should be designed with the machine operator in mind. To ensure effective and safe operator use,

guards and devices should suit the operation. For example, if an operation is prone to jamming, installing a fixed guard may not work. An interlocked guard or presence-sensing device may be a more practical solution.

What Administrative Issues Must Be Considered When Safeguarding Machinery?

As an employer, you need to consider house-keeping practices, employee apparel, and employee training. Implement good housekeeping practices to promote safe working conditions around machinery by doing the following:

- Remove slip, trip, and fall hazards from the areas surrounding machines;
- Use drip pans when oiling equipment;
- Remove waste stock as it is generated;
- Make the work area large enough for machine operation and maintenance; and
- Place machines away from high traffic areas to reduce worker distraction.

Workers should not wear loose-fitting clothing, jewelry, or other items that could become entangled in machinery, and long hair should be worn under a cap or otherwise contained to prevent entanglement in moving machinery.

Adequate instruction in the safe use of machines and supervised on-the-job training are essential in preventing amputation injuries. Only trained employees should operate machinery.

16 Controlling Amputation Hazards

Train Employees in the Following:

- All hazards in the work area, including machine-specific hazards;
- Safe work practices and machine operating procedures;
- The purpose and proper use of machine safeguards; and
- All procedures for responding to safeguarding problems such as immediately reporting unsafe conditions such as missing or damaged guards and violations of safe operating practices to supervisors.

In addition to employee instruction and training, you should provide adequate supervision to reinforce safe practices. Take disciplinary action to enforce safe work practices and working conditions.

Are There Standards for Machine Safeguards?

Yes, there are specific OSHA standards for machine guarding. The OSHA General Industry machine guarding requirements are established in 29 *CFR* Part 1910 Subpart O. Section 1910.212 establishes general regulations that apply to all machines and operations. Section 1910.219 covers the principal requirements for the guarding of most power-transmission apparatus. The other sections of Subpart O provide more detailed requirements for specific machinery.

29 CFR Part 1910 Subpart O—Machinery and Machine Guarding

- 1910.211—*Definitions.*
- 1910.212—*General requirements for all machines.*
- 1910.213—*Woodworking machinery requirements.*
- 1910.215—*Abrasive wheel machinery.*
- 1910.216—*Mills and calenders in the rubber and plastics industries.*
- 1910.217—*Mechanical power presses.*
- 1910.218—*Forging machines.*
- 1910.219—*Mechanical power-transmission apparatus.*

The OSHA Construction Industry machine guarding requirements are in 29 *CFR* Part 1926 Subpart I. Section 1926.300 establishes general regulations that apply to all machines and operations. Section 1926.307 covers the principal requirements for the guarding of most power-transmission apparatus. The other sections of Subpart I provide more detailed requirements for specific machinery.

29 CFR Part 1926 Subpart I—Tools—Hand and Power

- 1926.300—*General requirements.*
- 1926.301—*Hand tools.*
- 1926.302—*Power-operated hand tools.*
- 1926.303—*Abrasive wheels and tools.*
- 1926.304—*Woodworking tools.*
- 1926.305—*Jacks—lever and ratchet, screw, and hydraulic.*
- 1926.306—*Air receivers.*
- 1926.307—*Mechanical power-transmission apparatus.*

As discussed earlier, there are many machines associated with amputation hazards, but the ones presented here are most frequently involved in amputations. The types of machinery listed here rank from those with the most amputations to those with fewer injuries for all industries.¹ For other types of hazardous equipment and machinery, see Appendix B. In addition, as an employer you should consult the OSHA standard for specific machinery to ensure compliance with all requirements.

Machinery Associated with Amputations

1. Mechanical Power Presses
2. Power Press Brakes
3. Powered and Non-Powered Conveyors
4. Printing Presses
5. Roll-Forming and Roll-Bending Machines
6. Shearing Machines
7. Food Slicers
8. Meat Grinders
9. Meat-Cutting Band Saws
10. Drill Presses
11. Milling Machines
12. Grinding Machines
13. Slitters

What Are Mechanical Power Presses and Their Hazards?

Although there are three major types of power presses—mechanical, hydraulic, and pneumatic—the machinery that accounts for a large number of workplace amputations are mechanical power presses.

¹U.S. Department of Labor, OSHA, Office of Statistics, 1999. Based on BLS Annual Survey data for the number of amputations by source and type of event for various industry divisions and industries with high rates and high numbers of amputations in 1995.

In mechanical power presses, tools or dies are mounted on a slide, or ram, which operates in a controlled, reciprocating motion toward and away from the stationary bed or anvil containing the lower die. When the upper and lower dies press together on the workpiece, a re-formed piece is produced. Once the downstroke is completed, the re-formed workpiece is removed either automatically or manually, a new workpiece is fed into the die, and the process is repeated. (See Figure 23.)

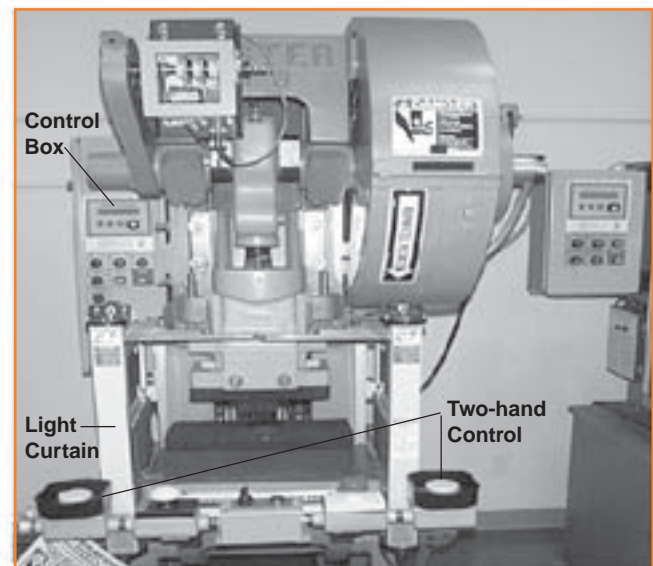

Figure 23. Part Revolution Mechanical Power Press with Two-Hand Control

Amputations occurring from point of operation hazards are the most common types of injuries associated with mechanical power presses. Inadequate safeguarding allows the operators to inadvertently activate the power press's tripping mechanism while their fingers are in the die (point of operation). For example, amputations can occur when an operator instinctively reaches into the point of operation to adjust a misaligned part or release a jam. Amputations also occur when an operator's normal feeding rhythm is interrupted, resulting in inadvertent placement of the operator's hands in the point of operation. Such injuries typically happen while the operator is riding the

18 Identifying Hazards for Specific Types of Machinery

foot pedal. Examples of inadequate or ineffective safeguarding include the following:

- Guards and devices disabled to increase production, to allow the insertion of small-piece work, or to allow better viewing of the operation.
- Two-hand trips/controls bridged or tied-down to allow initiation of the press cycle using only one hand.
- Devices such as pullbacks or restraints improperly adjusted to fit the specific operator.
- Controls of a single-operator press by-passed by having a co-worker activate the controls while the operator positions or aligns parts in the die, or repairs or troubleshoots the press.
- Failure to properly lockout/tagout presses or to have a special method in place for making adjustments, clearing jams, performing maintenance, installing or aligning dies, or cleaning the machine.

Case History #1

While using an unguarded, foot pedal-operated, full-revolution mechanical power press that made trip collars for wood stoves, an employee used his hands to feed and remove finished parts and scrap metal. He placed the completed part to the left side of the press, then turned to place the scrap in the bin behind him. As he turned back to face the press, he inadvertently stepped on the foot pedal and activated the press while his hand was in the die area. His left hand was amputated at the wrist.

Case History #2

An employee was operating an unguarded 10-ton, full-revolution mechanical power press to stamp mailbox parts, and using a hand tool to load the press, she placed her left hand in the lower die to reposition a misaligned part. At the same time, she inadvertently depressed the foot pedal, activating the press and crushing her left index finger.

Some amputations are linked to machine failure, such as failure of a single-stroke linkage resulting in a “double cycle,” electronic failure of two-hand controls, brake failure resulting in the slide falling, and jammed relays in light curtains.

How Do I Safeguard My Mechanical Power Presses?

Mechanical power presses are extremely versatile, and selecting appropriate safeguarding methods depends on the specific press design and use. You should consider the press, the type of clutch used, the stock size, the length of production runs, and the method of feeding.

You can use engineering controls such as guards to prevent injuries. For example, 29 *CFR* 1910.217 requires employers to provide and ensure the use of point of operation guards or properly installed devices on every operation performed on a press when the die opening is greater than 1/4 inch. If the dies of a power press can be adjusted so that they never open more than 1/4 inch, there is no need for a point of operation guard. This is referred to as “stroke limitation” and is a good choice when practical.

In addition, guards must conform to the maximum permissible openings of Table O-10 of 29 *CFR* 1910.217. Guards must prevent entry of hands or fingers into the point of operation through, over, under, or around the guard.

Mechanical Power Press Safeguarding Methods by Clutch Type

Full-Revolution Clutch	Part-Revolution Clutch
Point of Operation Guard	Point of Operation Guard
Pullback	Pullback
Restraint	Restraint
Type A Gate	Type A or B Gate
Two-Hand Trip	Two-Hand Control
	Presence-Sensing Device

Mechanical power press point of operation safeguards must accomplish the following goals:

- Prevent or stop the normal press stroke if the operator’s hands are in the point of operation; or
- Prevent the operator from reaching into the point of operation as the die closes; or
- Withdraw the operator’s hands if inadvertently placed in the point of operation as the die closes; or
- Prevent the operator from reaching the point of operation at any time; or
- Require the operator to use both hands for the machine controls that are located at such a distance that the slide completes the downward travel or stops before the operator can reach into the point of operation; or
- Enclose the point of operation before a press stroke can be started to prevent the operator from reaching into the danger area before die closure or enclose the point of operation prior to cessation of the slide motion during the downward stroke.

Source: 29 *CFR* 1910.217(c)(3)(i)

What Work Practices and Administrative Controls Should I Use?

“No Hands in Die” Policy

A “no hands in die” policy should be implemented and followed whenever possible. Under this policy, operators never place their hands in the point of operation (die area). Adherence to this policy would eliminate point of operation amputations.

The types of work practices and administrative controls you provide can make a big difference in reducing the potential for amputation hazards. For example, if workers operate presses under a “no hands in die” policy using feeding methods such as hand-tool feeding, safeguarding (two-hand trip, Type A and B gates, or presence-sensing device) you still must protect operators. Hand-tool feeding alone does not ensure that the operator’s hands cannot reach the danger area. (Figure 24 illustrates the use of hand feeding tools in conjunction with pullbacks on a power press.)

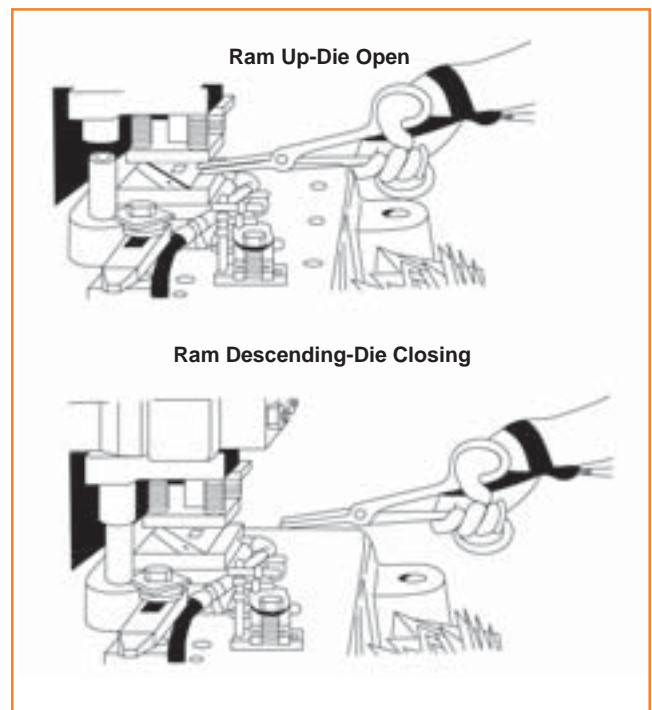

Figure 24. Hand Feeding Tools Used in Conjunction with Pullbacks on a Power Press

Removing scrap or stuck work with tools is required even when hand feeding is allowed according to 29 *CFR* 1910.217(d)(1)(ii). You must furnish and enforce the use of hand tools for freeing or removing work or scrap pieces from the die to reduce the amount of time an operator’s hand is near the point of operation.

What Other Controls Pertain to Mechanical Power Press Die Set-Up and Maintenance?

For example, always do the following:

- Control point of operation hazards created when guards are removed for set-up and repair by operating the machine in the inch mode. This involves using two-hand controls to gradually inch the press through a stroke when the dies are being tested on part-revolution clutch presses.
- Avoid making machine repairs or modifications while the machine can be stroked.
- Prevent stroking by using die blocks or interlocked barrier guards.
- Disconnect or remove foot controls while die work is being performed if they are used to initiate the stroke.

What Type of Training Should I Provide?

Training is essential for worker protection. As an employer, you should

- Train operators in safe mechanical press operation procedures and techniques before they begin work on the press.
- Supervise operators to ensure that correct procedures and techniques are being followed.

What Work Practices Should I Use?

In addition, work practices such as regular mechanical power press inspection, maintenance, recordkeeping, and reporting are essential.

- 29 *CFR* 1910.217(e)(1)(i) requires a program of periodic and regular inspections of mechanical power presses. You must inspect and test the condition of the clutch/brake mechanism, anti-repeat feature, and single-stroke mechanism and maintain records of these inspections and the maintenance performed.
- 29 *CFR* 1910.217(g), requires the reporting of all point of operation injuries within 30 days to either the Director of the Directorate of Safety Standards Programs, OSHA, U.S. Department of Labor, Washington, DC 20210, or the state agency administering a plan approved by OSHA.

- 29 *CFR* 1910.147 requires the performance of servicing and maintenance activities under an energy control program.

Applicable Standards

- 29 *CFR* 1910.217, *Mechanical power presses*.
- 29 *CFR* 1910.219, *Mechanical power-transmission apparatus*.
- 29 *CFR* 1910.147, *The control of hazardous energy (lockout/tagout)*.

Sources of Additional Information

- OSHA Instruction CPL 2-1.24A, *National Emphasis Program on Amputations*
- OSHA publication 3067, *Concepts and Techniques of Machine Safeguarding* (<http://www.osha.gov/pls/publications/pubindex.list#3067>)
- OSHA Technical Links—Machine Guarding (<http://www.osha-slc.gov/SLTC/machineguarding/index.html>)
- OSHA Lockout/Tagout Interactive Training Program (<http://www.osha-slc.gov/dts/osta/lototraining/index.htm>)
- NIOSH CIB 49, *Injuries and Amputations Resulting From Work With Mechanical Power Presses* (May 22, 1987)
- OSHA Instruction STD 1-12.21—29 *CFR* 1910.217, *Mechanical Power Presses, Clarifications* (10/30/78)
- ANSI B11.1-1988 (R1994), *Machine Tools—Mechanical Power Presses, Safety Requirement for Construction, Care, and Use*

What Do I Need to Know About Power Press Brakes?

Power press brakes are similar to mechanical power presses in that they use vertical reciprocating motion and are used for repetitive tasks. Press brake operation is either mechanical or hydraulic. Press brakes are either general-purpose or special-purpose brakes, according to ANSI B11.3, *Power*

Press Brakes, Safety Requirements for the Construction, Care, and Use of. General-purpose press brakes have a single operator control station. A servo-system activates the special-purpose brake which may be equipped with multiple operator/helper control stations. (See Figure 25 for a power press brake operation.)



Figure 25. Power Press Brake Bending Metal

What Are the Hazards Associated with Power Press Brakes?

As with mechanical power presses, point of operation injuries are the most common type of injury associated with power press brakes. Here are some frequent causes of amputations from power press brakes:

- Foot controls being inadvertently activated while the operator’s hand is in the point of operation. The likelihood of this type of injury increases as the size of stock decreases and brings the operator’s hands closer to the point of operation.
- Parts of the body caught in pinch points created between the stock and the press brake frame while the bend is being made.

- Controls of a single-operator press bypassed by having a coworker activate the controls while the operator positions or aligns stock or repairs or troubleshoots the press.
- Failure to properly lockout/tagout presses or to have an alternative measure that provides effective protection for safety during the necessary tasks of making adjustments, clearing jams, performing maintenance, installing or aligning dies, or cleaning the machine.

Case History #3

An operator was bending small parts using an 80-ton unguarded press brake. This required the employee’s fingers to be very close to the point of operation and consequently, the operator lost three fingers when his hand entered the point of operation. The operator on the previous shift had reported to the supervisor that the operator placed his fingers close to the point of operation, but was told nothing could be done but that the operator should be careful.

Case History #4

An operator was bending metal parts using a 36-ton part-revolution power press brake that was foot-activated and equipped with a light curtain. About 3-4 inches of the light curtain had been “blanked out” during a previous part run. While adjusting a part at the point of operation, the employee accidentally activated the foot pedal and amputated three finger tips.

How Can I Safeguard Power Press Brakes?

Engineering controls, work practices, and administrative controls can be used to effectively guard power press brakes. Engineering controls such as presence-sensing devices are sometimes used to safeguard power press brakes. When installed on special-purpose press brakes, these devices may

require muting or balancing to allow the bending material to move through the protected zone. Always ensure that these devices are properly adjusted for the specific stock and task to be performed. Failure to adjust the device could leave it “blanked out” in certain areas and expose operators to point of operation hazards.

Be sure to safeguard general-purpose power press brakes by location, or by barrier guard, pullbacks, or restraints when operated by a single operator and helper. (Figure 26 shows a general-purpose power press brake used in conjunction with pullbacks.) Other forms of helper safeguarding are ineffective and not applicable to general-purpose power press brakes. Special-purpose power press brakes are equipped with advanced control systems that are adaptable to all forms of safeguarding concepts and devices, such as two-hand controls and multiple operator/helper actuating controls. Use anti-repeat devices to protect operators at the point of operation on special-purpose power press brakes to comply with ANSI B11.3.

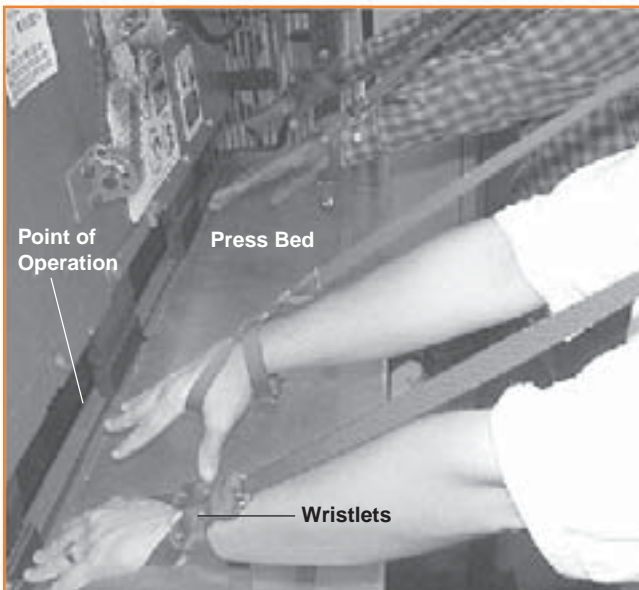

Figure 26. Two Person Power Press Brake Operation with Pullbacks

Under some conditions, absolute safeguarding of power press brakes may be impractical. This is especially true for press brakes used to process small-quantity runs involving the fabrication of unique pieces. When absolute physical guarding is impractical or infeasible for small quantity runs, OSHA recognizes the use of a “safe distance” as an alternative safeguarding method. Additional information about a “safe distance” safeguarding program can be found in OSHA CPL 2-1.25—*Guidelines for Point of Operation Guarding of Power Press Brakes*.

What About Work Practices and Administrative Controls for Power Press Brakes?

- Implement the following work practices to ensure safe operation of power press brakes with foot pedals, especially when the operator is working with small parts:
 - Use foot pedals only with other guards or devices but keep a safe distance between the operator’s hand and the point of operation when the use of such safeguards is not feasible.
 - Be certain that the stock size is large enough to ensure that the operator is unable to reach into the point of operation during the down stroke when a foot control is used to stroke the press brake.
 - Don’t ride the foot pedal.
 - Protect foot pedals from accidental activation and continuous cycling.
 - Use hand-feeding tools for operations when the operator’s hands come closer to the point of operation as the size of stock decreases.
- Ensure that all power press brake operators receive appropriate training from experienced operators and supervision until they can work safely on their own.
- Develop and implement safe operating procedures for power press brakes and conduct periodic inspections to ensure compliance.
- Require workers to perform servicing and maintenance activities under an energy control program in accordance with 29 *CFR* 1910.147.

Applicable Standards

- 29 CFR 1910.212, *General requirements for all machines.*
- 29 CFR 1910.219, *Mechanical power-transmission apparatus.*
- 29 CFR 1910.147, *The control of hazardous energy (lockout/tagout).*

Sources of Additional Information

- OSHA publication 3067, *Concepts and Techniques of Machine Safeguarding* (http://www.osha-slc.gov/Publications/Mach_SafeGuard/)
- OSHA Technical Links—*Machine Guarding* (<http://www.osha-slc.gov/SLTC/machineguarding/index.html>)
- OSHA Lockout/Tagout Interactive Training Program (<http://www.osha-slc.gov/dts/osta/lototraining/index.htm>)
- OSHA Directive - CPL 2-1.25, *Guidelines for Point of Operation Guarding of Power Press Brakes*
- OSHA Interpretation - 1910.212, *Point of Operation Guarding on Power Press Brakes* (03/25/1983)
- ANSI B11.3-1982 (R1994), *Power Press Brakes, Safety Requirements for the Construction, Care, and Use of*

What Are the Hazards Associated with Conveyors?

Conveyor-related injuries typically involve a worker’s hands or fingers becoming caught in nip points or shear points on conveyors and may occur in these situations:

- Cleaning and maintaining a conveyor especially when it is still operating.
- Reaching into an in-going nip point to remove debris or to free jammed material.
- Allowing a cleaning cloth or an employee’s clothing to get caught in the conveyor and pull the worker’s fingers or hands into the conveyor.

Other conveyor-related hazards include improperly guarded sprocket and chain drives. Overhead conveyors warrant special attention because most of the conveyor’s drive train is exposed. Employees have also been injured while stepping or walking on or near conveyors.

Case History #5

While removing a cleaning rag from the ingoing nip point between the conveyor belt and its tail pulley (non-powered end of the conveyor), an employee’s arm became caught in the pulley, which amputated his arm below the elbow.

Case History #6

While servicing a chain-and-sprocket drive assembly on a roof tile conveyor system, an employee turned off the conveyor, removed the guard, and began work on the drive assembly without locking out the system. When someone started the conveyor, the employee’s fingers became caught in the chain-and-sprocket drive and were amputated.

What Do I Need to Know About Conveyors?

Conveyors are used in many industries to transport materials horizontally, vertically, at an angle, or around curves. Types include non-powered and powered, live roller, slat, chain, screw, and pneumatic. Conveyors eliminate or reduce manual material handling tasks, but they present amputation hazards associated with mechanical motion. (See Figures 27 through 30 for examples of common conveyors.)

24 Identifying Hazards for Specific Types of Machinery

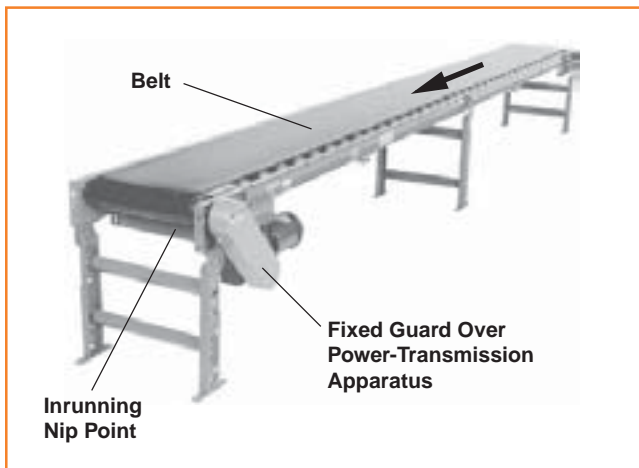

Figure 27. Belt Conveyor

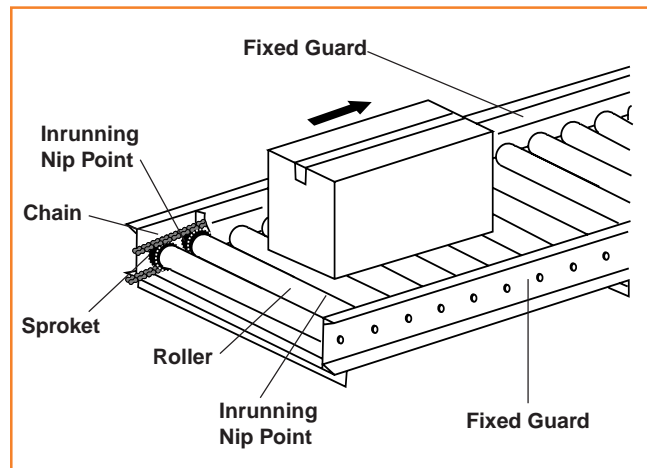

Figure 29. Chain Driven Live Roller Conveyor

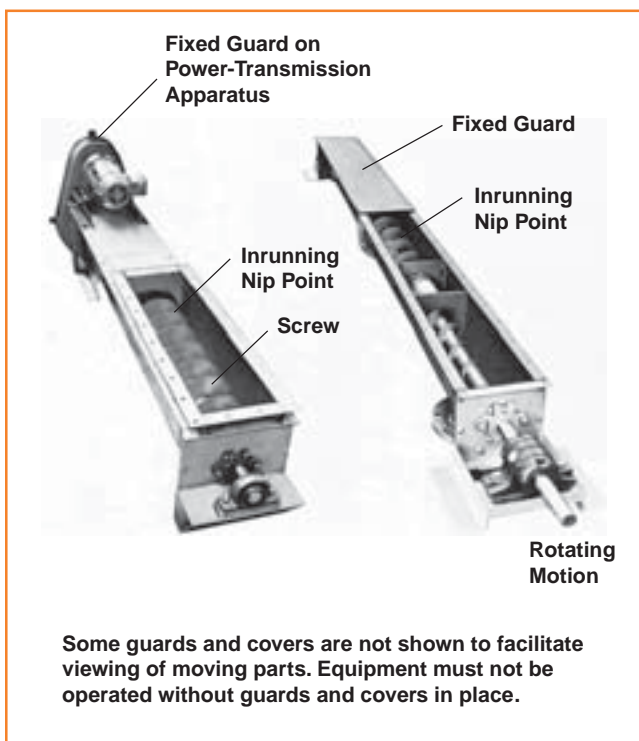

Figure 28. Screw Conveyor

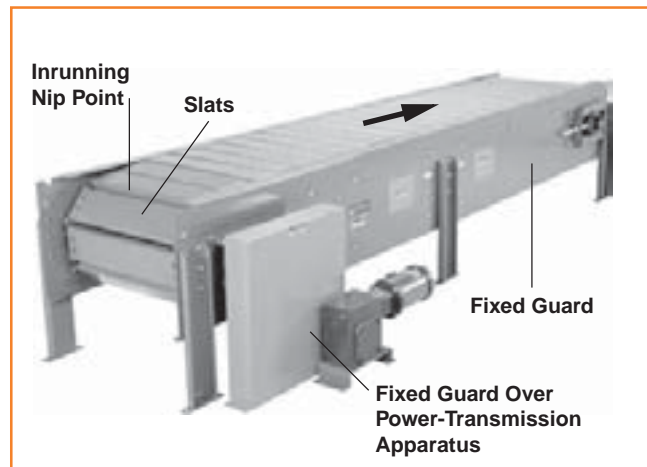

Figure 30. Slat Conveyor

What Types of Engineering Controls Should I Use for Conveyors?

Some general controls you might use include the following:

- Install guards for all sprockets, chains, rollers, belts, and other moving parts. Guarding by location—locating moving parts away from employees to prevent accidental contact with the hazard point—is one option for guarding conveyors. It is particularly difficult, however, to use this method when guarding the in-going nip points on certain conveyors such as roller

conveyors because the exposed rollers are crucial to the function of the conveyor.

- Use prominent warning signs or lights to alert workers to the conveyor operation when it is not feasible to install guarding devices because they interfere with the conveyor's operation.
- Ensure that all conveyor openings such as wall and floor openings, and chutes and hoppers, have guards when the conveyor is not in use.
- Ensure that start buttons have guards to prevent accidental operation.
- Ensure that conveyor controls or power sources can accept a lockout/tagout device to allow safe maintenance practices.

For crossovers, aisles, passageways, you need to do the following:

- Ensure that all accesses and aisles that cross over or under or are adjacent to the conveyor have adequate clearance and hand rails or other guards.
- Place crossovers in areas where employees are most likely to use them.
- Ensure that all underpasses have protected ceilings.
- Post appropriate hazard warning signs at all crossovers, aisles, and passageways.
- Considering emergency egress when determining placement of crossovers, aisles, and passageways.

For emergency stops or shut-offs, you will need these engineering controls:

- Equip conveyors with interlocking devices that shut them down during an electrical or mechanical overload such as product jam or other stoppage. When conveyors are arranged in a series, all should automatically stop whenever one stops.
- Equip conveyors with emergency stop controls that require manual resetting before resuming conveyor operation.
- Install clearly marked, unobstructed emergency stop buttons or pull cords within easy reach of workers.

- Provide continuously accessible conveyor belts with emergency stop cables that extend the entire length of the conveyor belt to allow access to the cable from any point along the belt.

Typical Conveyor Hazards and Safeguarding Methods

Belt conveyors

Hazards: Conveyor take-up and discharge ends, where the belt or chain enters or exits the in- going nip point; where the belt wraps around pulleys; where the belt changes direction, such as take-ups; or where multiple conveyors are adjoined.

Controls: Guarding of belt conveyors is not always feasible because guarding devices interfere with normal operation. Options for hazard control include guarding by distance as well as installing hazard warning signs and signals.

Screw conveyors

Hazards: In-going nip points of turning helical flights for the entire length of the screw conveyor when the housing is opened.

Controls: Screw conveyor housing should completely enclose the moving elements of the conveyor except for the loading and discharge points. If such guarding is not feasible, the entire conveyor should be guarded by railing unless it is guarded by location—the hazardous areas cannot be easily accessed by employees. Permanently affixed grids or Plexiglass™ can be installed to allow the operator to inspect the operation. Open troughs can be used if such covers are not feasible; but they should be guarded by location. Alternatively, the trough side walls should be high enough to prevent employees from reaching over falling into the trough.

Typical Conveyor Hazards and Safeguarding Methods (Continued)

Chain conveyors

Hazards: Moving chains since the chains can not be enclosed without impairing the function of the conveyor.

Controls: Guarding of chain conveyors is not always feasible because guarding devices interfere with normal operation. Options for hazard control include guarding by distance and installing hazard warning signs and signals.

Roller conveyors

Hazards: In-going nip points between the drive chain and sprockets; nip points between belt and carrier rollers; and nip points at terminals, drives, take-ups, idlers, and snub rollers.

Controls: Roller conveyors should have permanent guards that can be adjusted as necessary to protect the worker. For example, when transporting small items on a roller conveyor that does not require the use of the entire roller width, the unused section of rollers closest to the workers should be guarded.

What Work Practices and Administrative Controls Do I Need to Use?

- Develop and implement safe operating procedures for conveyors and conduct periodic inspections to ensure compliance.
- Allow only trained individuals to operate conveyors and only trained, authorized staff to perform maintenance.
- Train employees working with or near conveyors regarding the location and use of emergency stopping devices and the proper procedures for conveyor operation.

- Forbid employees to ride on conveyors.
- Instruct employees to cross over or under conveyors only at properly designed and safeguarded passageways.
- Instruct employees to lubricate, align, and maintain conveyors when the conveyor is stopped. If this is impractical, advise workers to perform this work at a safe distance from any in-going nip points or pinch points. Installing extended oiler tubes and adjusting screws will help in these instances.
- Prohibit employees working with or near conveyors from wearing loose clothing or jewelry, and require them to secure long hair with nets or caps.
- Perform servicing and maintenance under an energy control program in accordance with 29 CFR 1910.147.

Applicable Standards

- 29 CFR 1926.555, *Conveyors*.
- ANSI B20.1-57, *Safety Code for Conveyors, Cableways, and Related Equipment* [incorporated by reference in 1926.555 (a)(8)]
- 29 CFR 1910.212, *General requirements for all machines*
- 29 CFR 1910.219, *Mechanical power-transmission apparatus*
- 29 CFR 1910.147, *The control of hazardous energy (lockout/tagout)*

Sources of Additional Information

- OSHA publication 3067, *Concepts and Techniques of Machine Safeguarding* (http://www.osha-slc.gov/Publications/Mach_SafeGuard/)
- OSHA Technical Links—Machine Guarding ([http://www.osha-slc.gov/SLTC/machine guarding/ index.html](http://www.osha-slc.gov/SLTC/machine%20guarding/index.html))
- OSHA Lockout Tagout Interactive Training Program ([http://www.osha-slc.gov /dts/osta/lototraining/index.htm](http://www.osha-slc.gov/dts/osta/lototraining/index.htm))
- ANSI/ASME B20.1-1996, *Safety Standard for Conveyors and Related Equipment*
- ANSI/CEMA 350-1988, *Screw Conveyors*
- ANSI/CEMA 402-1992, *Unit Handling Conveyors—Belt Conveyors*
- ANSI/CEMA 404-1985, *Unit Handling Conveyors—Chain Driven Live Roller Conveyors*
- ANSI/CEMA 403-1985, *Unit Handling Conveyors—Belt Driven Live Roller Conveyors*
- ANSI/CEMA 401-1994, *Unit Handling Conveyors—Roller Conveyors—Non-powered*
- ANSI/CEMA 405-1985, *Package Handling Conveyors—Slat Conveyors*

What Are the Hazards from Printing Presses?

Printing presses vary by type and size, ranging from relatively simple manual presses to the complex large presses used for printing newspapers, magazines, and books. Printing presses are often part of a larger system that also includes cutting, binding, folding, and finishing equipment. Many modern printing presses rely on computer controls, and the high speeds of such equipment often require rapid machine adjustments to avoid waste.

This section discusses amputation hazards associated with two common types of printing

presses: web-fed and sheet-fed printing press systems. Web-fed printing presses are fed by large continuous rolls of substrate such as paper, fabric or plastic; sheet-fed printing presses, as their name implies, are fed by large sheets of substrate. In both types, the substrate typically feeds through a series of cylinders containing printing plates and supporting cylinders moving in the opposite direction. (Figures 31 and 32 illustrate a roll-to-roll offset printing press and a sheet-fed offset printing press.)

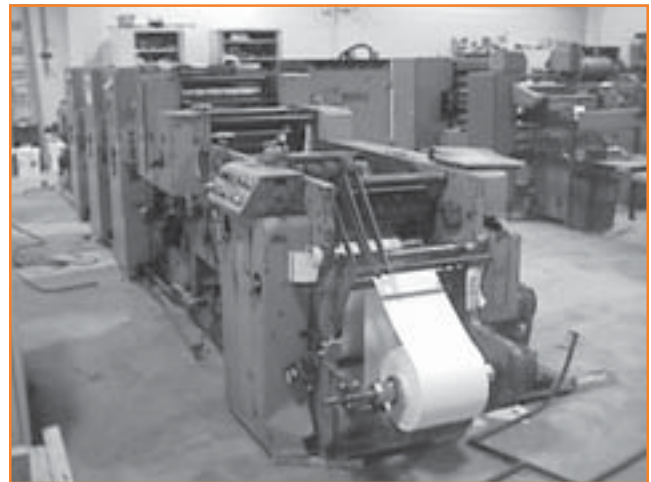

Figure 31. Roll-to-Roll Offset Printing Press

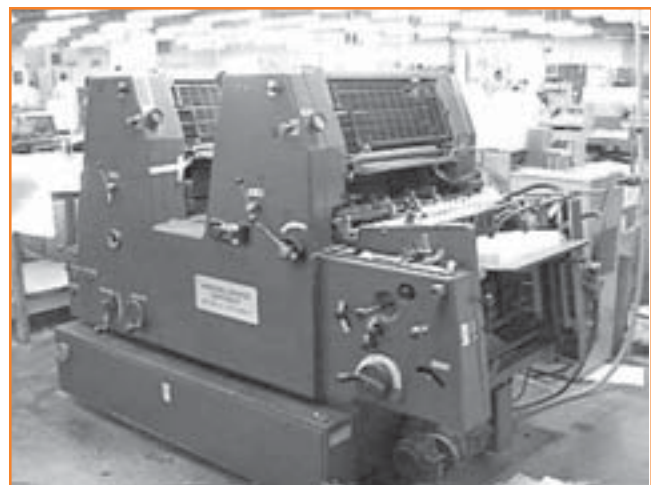

Figure 32. Sheet-Fed Offset Printing Press

28 Identifying Hazards for Specific Types of Machinery

As with other machines, many printing press-related amputations occur during cleaning and maintenance activities. For example, amputations frequently occur when workers get their fingers or hands caught in the in-going nip points created between two rollers while performing these tasks:

- Cleaning or attempting to free material from the rollers.
- Hand-feeding substrate into the in-running rollers during press set-up while the machine is operating.

Case History #7

An employee was adding ink at the top of a printing press when he spotted a small piece of wood in the area of the moving rollers. He caught his hand in the moving rollers as he attempted to remove the wood and had to have his forearm surgically amputated.

Case History #8

An offset printing press operator lost his right hand while attempting to remove dried ink on a moving roller using a rag. The guard covering the lower ink train rollers had been flipped up, exposing the rollers. The rag got caught in a nearby roller, pulling the employee's hand into the in-going nip point. The employee immediately hit the *press stop button* but the roller rotated one-half turn before stopping. His hand was crushed and had to be amputated at the hospital.

Source: OSHA IMIS Accident Investigation Database

What Types of Controls Can I Use to Safeguard Printing Presses?

As with most machinery, you can rely on engineering, work practice, and administrative controls to protect employees against injuries when using printing presses. For example, some basic engineering controls include the following:

- Install guarding on all hazard points, including all accessible in-going nip points between rollers

and power-transmission apparatus (such as chains and sprockets), that are accessible during normal operation.

- Safeguard nip point hazards with barrier guards or nip guards. Nip guards should be designed and installed without creating additional hazards. For example, the distance between the nip guard and the adjacent roller/cylinder should be minimized. Additionally, to prevent wedging, the angle between the nip guard and the surface of the roller should not be less than 60 degrees.
- Install fixed barrier guards at rollers that do not require operator access.
- Use fixed guards that can only be opened with tools (to prevent tampering) at points requiring operator access once per shift or less.
- When you need more frequent access to the press, use interlocked guards, which are designed to stop the printing press when opened or moved, instead of fixed guards. Interlocked guards should not allow normal operation of the press while open.
- Use an inch or reverse function to perform actions such as substrate feeding, machine adjustment, and lubrication when one or more interlocked guards is moved to allow operator access. The speed and distance of the inch function should be designed to ensure that it does not pose a hazard if not otherwise guarded.
- Require press operators to perform normal start-up procedures before the press can be operated. Replacing an interlocked guard should not automatically trigger machine operation.
- Use additional safeguarding methods such as guarding by location as well as devices for stopping the printing press such as trip bars and pull cords.
- Remember that interlocks and stops do not stop the press immediately and that non-driven idler rollers may continue to rotate when the press is stopped and can cause injury.

All printing presses should incorporate a signaling system in accordance with ANSI B65.1-1995 as follows:

- Make sure that printing presses attended by more than one operator or ones outside of the operator’s viewing area be equipped with visual and audible warning devices to alert workers regarding the press’s operational status—in operation, safe mode, or impending operation.
- Install visual warning devices of sufficient number and brightness and locate them so that they are readily visible to press personnel.
- Ensure that audible alarms are loud enough to be heard above background noise.
- Provide a warning system that activates for at least 2 seconds prior to machine motion.

What Are the Work Practices and Administrative Controls I Can Use for Printing Presses?

Work practices and administrative controls recommended for printing presses include the following:

- Develop and implement safe operating procedures for printing presses and conduct periodic inspections to ensure compliance.
- Ensure that all press operators receive appropriate training and supervision until they can work safely on their own.
- Instruct workers to lubricate, align, and maintain printing presses only when presses are stopped. If this is impractical, advise employees to maintain a safe distance from any in-going nip points. Installing extended oiler tubes and adjusting screws will help in these instances.
- Prohibit employees working with or near printing presses from wearing loose clothing or jewelry and require them to secure long hair with a net or cap.
- Perform servicing and maintenance activities under an energy control program in accordance with 29 CFR 1910.147.

In addition, perform minor servicing tasks using the Inch-Safe-Service procedure specified in ANSI B65.1. These include the following tasks: clearing

certain types of paper jams; minor cleaning, lubricating, and adjusting operations; certain plate-changing and blanket-changing tasks; and, in some cases, webbing and paper roll changing. The Inch-Safe-Service procedure, at a minimum, calls for the use of a stop/safe drive push-button control. Under this procedure, the stop/safe function cannot serve as the energy control device when you are performing lockout.

Applicable Standards

- 29 CFR 1910.212, *General requirements for all machines.*
- 29 CFR 1910.219, *Mechanical power-transmission apparatus.*
- 29 CFR 1910.147, *The control of hazardous energy (lockout/tagout).*

Sources of Additional Information

- OSHA publication 3067, *Concepts and Techniques of Machine Safeguarding* (http://www.osha-slc.gov/Publications/Mach_SafeGuard/)
- OSHA Technical Links—Machine Guarding (http://www.osha-slc.gov/SLTC/machine_guarding/index.html)
- OSHA Lockout/Tagout Interactive Training Program (<http://www.osha-slc.gov/dts/osta/lototraining/index.htm>)
- ANSI B65.1-1995, *Safety Standard-Printing Press Systems*

What Are the Hazards from Roll-Forming and Roll-Bending Machines?

Roll-forming and roll-bending machines primarily perform metal bending, rolling, or shaping functions. Roll forming is the process of bending a continuous strip of metal to gradually form a pre-determined shape using a self-contained machine. Roll-forming machines may also perform other processes on the metal, including piercing holes, slots, or notches; stamping; flanging; and stretch-bending. Roll bending is essentially the same process, except that the machine produces a bend across the width of flat or pre-formed metal to achieve a curved or angular configuration.

30 Identifying Hazards for Specific Types of Machinery

Roll-forming and roll-bending machines frequently are set up and operated by one person. (Figure 33 illustrates a roll-forming machine producing a finished product. Figure 34 illustrates the in-feed section of a roll-forming machine.)

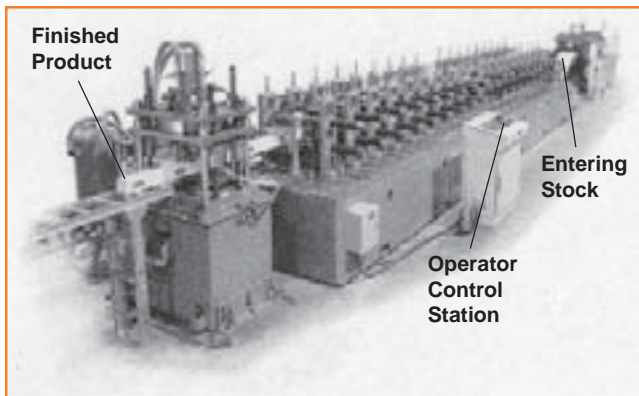

Figure 33. Roll-Forming Machine

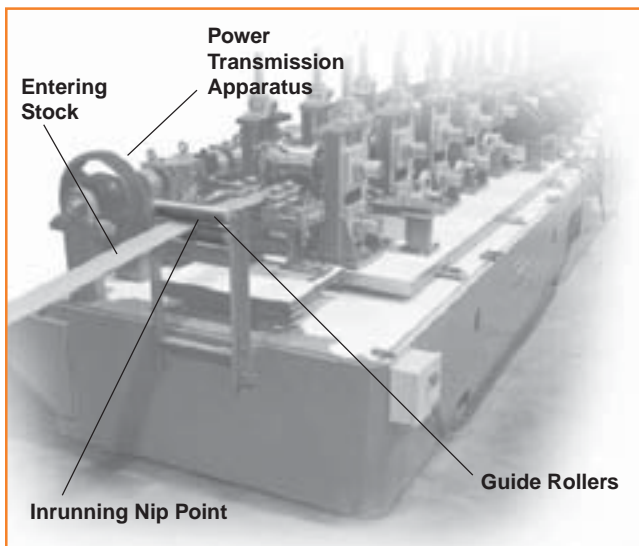

Figure 34. Infeed Area of a Roll-Forming Machine

The most common type of amputation hazard associated with roll-forming and roll-bending machines are point of operation hazards created by in-running nip points. Amputations occur when the hands of the operator feeding material through the rolls get caught and are then pulled into the point of

operation. Causes of amputations related to roll-forming and roll-bending machines can occur from the following:

- Having an unguarded or inadequately guarded point of operation;
- Locating the operator control station too close to the process;
- Activating the machine inadvertently; and
- Performing cleaning, clearing, changing, or inspecting tasks while the machine is operating or is not properly locked or tagged out.

Case History #9

While feeding a metal sheet into a roller, an employee caught his right hand in the roller and amputated one finger.

Case History #10

An employee wearing gloves caught his left hand in a roll-forming machine, resulting in partial amputation of two fingers. The employee was standing close to the moving rollers, feeding flat steel sheet from behind and catching it on the front side. There was no point of operation guard on the front roller and the foot operating pedal was very close to the machine.

What Engineering Controls Should I Use to Protect Employees?

Roll-forming and roll-bending machines are available in a wide variety of sizes and designs, and safeguarding methods must be tailored for each machine. Several factors affect the ways to safeguard the equipment, including machine size, operating speed, thickness of product, length of production runs, required production accuracy, sheet feeding methods, and part removal methods. Depending on the size and type of machine, a number of different safeguarding devices and

methods may be required to adequately protect the operator as well as other workers nearby. For example, you can do the following:

- Install fixed or adjustable point of operation guards at the in-feed and out-feed sections of machines. If the stock or end-product does not differ greatly from run to run, a fixed guard may be preferable. If the stock or end-product is variable, however, an adjustable guard may be more suitable.
- Install fixed point of operation guards to cover the sides of the rollers to prevent an employee from reaching into the in-going nip points of the rollers.
- Install fixed or interlocked guards to cover any other rotating parts, such as a power- transmission apparatus.
- Install safety trip controls, such as a pressure-sensitive body bar or safety tripwire cable on the in-feed section of the machine to shut down the machine if an employee gets too close to the point of operation.
- Install emergency stop controls that are readily accessible to the operator.
- Use an awareness barrier guard with an interlocking gate around the perimeter of the machine to prevent unauthorized entry.
- Locate foot pedal controls away from the point of operation and guard them in such a way as to prevent inadvertent activation.
- Allow only one control station to operate at any one time when a single machine has more than one set of operator controls, this does not apply to the emergency stop controls which must be operable from all locations at all times.
- Position operating stations in a way that ensures operators are not exposed to the machine's point of operation.
- Safeguard operator control stations to prevent inadvertent activation by unauthorized employees.

Are There Work Practice and Administrative Controls I Can Employ for These Machines?

Yes. You can also prevent hazards from this equipment by doing the following:

- Develop and implement safe operating procedures for roll-forming and roll-bending machines and conduct periodic inspections of the operation to ensure compliance.
- Ensure that all operators receive appropriate on-the-job training under direct supervision of experienced operators until they can work safely on their own.
- Ensure that operators use the jog mode during feeding operations if appropriate; and that they maintain a safe distance from the machine's rollers.
- Require workers to perform servicing and maintenance activities under an energy control program in accordance with 29 *CFR* 1910.147.

Applicable Standards

- 29 *CFR* 1910.212, *General requirements for all machines.*
- 29 *CFR* 1910.219, *Mechanical power-transmission apparatus.*
- 29 *CFR* 1910.147, *The control of hazardous energy (lockout/tagout).*

Sources of Additional Information

- OSHA publication 3067, *Concepts and Techniques of Machine Safeguarding* (http://www.osha-slc.gov/Publications/Mach_SafeGuard/)
- OSHA Technical Links—Machine Guarding (http://www.osha-slc.gov/SLTC/machine_guarding/index.html)
- OSHA Lockout/Tagout Interactive Training Program (<http://www.osha-slc.gov/dts/osta/lototraining/index.htm>)
- ANSI B11.12-1996 *Roll-Forming and Roll-Bending Machines—Safety Requirements for Construction, Care, and Use*

What Are Shearing Machines and Their Hazards?

Mechanical power shears contain a ram for their shearing action. The ram moves a non-rotary blade at a constant rate past the edge of a fixed blade. Shears may be mechanically, hydraulically, hydro-mechanically, pneumatically, or manually powered and are used to perform numerous functions such as squaring, cropping, and cutting to length.

In the basic shear operation, stock is fed into the point of operation between two blades. A hold-down may then be activated that applies pressure to the stock to prevent movement. One complete cycle consists of a downward stroke of the top blade until it passes the lower fixed blade followed by an upward stroke to the starting position. (See Figures 35 and 36 for examples of alligator and power squaring shears.)

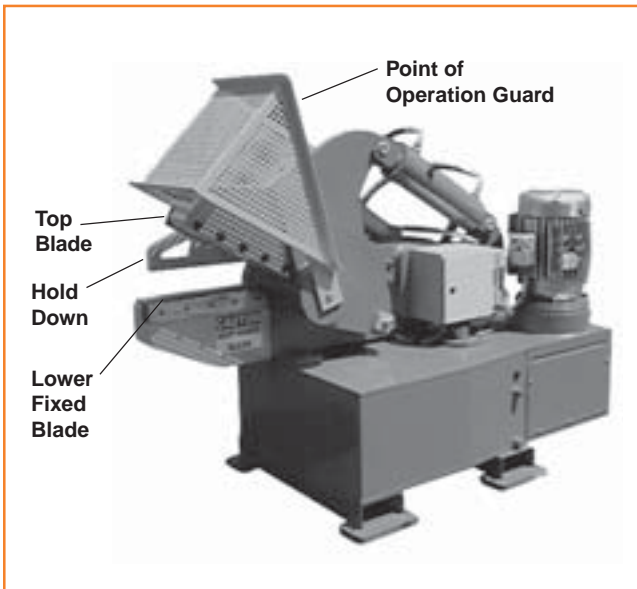

Figure 35. Hydraulic Alligator Shear



Figure 36. Power Squaring Shear

Shears can be categorized as stand-alone manual shears, stand-alone automatic shears, and process-line shears.

Stand-alone manual shears. An operator controls them from a control station. The operator feeds the shear either by hand or by activating the automatic loading mechanism and activates the equipment using hand or foot controls or a tripping device on the back side of the shear. An example is an alligator shear.

Stand-alone automatic shears. These feed and stroke automatically and continuously. The operator uses hand-activated or foot-activated controls to initiate the operation requiring limited additional operator interaction. An example is a guillotine shear.

Process-line shears. These are integrated into an automated production process and are controlled automatically as part of the process. Examples include crop shears and cut-to-length shears.

The primary hazard associated with shears is the shearing action at the point of operation. Amputations may occur in the following situations:

- The foot control inadvertently activates while the operator's hands are in the point of operation. Such amputations usually relate to foot-activated, stand-alone manual shears that require the use of both hands to feed the stock.
- A tripping device located on the back side of the shear's mouth operates the shear but does not prevent the operator from reaching into the hazard area. Such tripping devices, commonly found on stand-alone manual shears, may increase productivity but must be used in conjunction with appropriate safeguards.
- When there is no hold-down and stock being fed into a stand-alone manual shear kicks out and strikes the operator's hands or fingers.
- The shear is not equipped with either a full-revolution or a part-revolution clutch. Even after it is shut down, a shear that is not equipped with either type of clutch continues to cycle until its energy is exhausted.

Case History #11

After breaking metal with a mechanical alligator shear, an employee turned the shear off and was picking up debris on the ground when he placed his left hand on the shear and amputated his fingers. The shear's flywheel was not equipped with a clutch or similar device. So, when the shear was shut off, the jaw continued to operate on stored energy.

Case History #12

An employee was cutting material with a 50-inch guillotine shear equipped with two-hand trip buttons to prevent employees from reaching into the blade area. He had taped up one of the buttons and used his knee to trip the other button. With both hands under the blade he inadvertently hit the free button with his knee. This activated a stroke of the blade which amputated both of his hands just below the wrists.

What Controls Can I Use on Shearing Machines ?

Because shears have a wide variety of applications, safeguarding methods must be determined individually for each machine based on its use. A number of different safeguarding methods may be necessary to adequately protect the operator as well as other workers nearby. For example, you will need to consider the machine size, operating speed, size and type of material, length of production runs, required accuracy of the work, methods for material feeding and removal, operator controls, and clutch type.

Here are some engineering controls you should use:

- Use automatic-feeding devices such as conveyors with stand-alone manual shears when the material is uniform in size and shape.
- Equip mechanical shears with either a part-revolution or full-revolution clutch. Methods of safeguarding depend on the type of clutch in use. Shears equipped with full-revolution clutches used in single-stroke operations must be equipped with an anti-repeat feature.

The following recommendations apply to safeguarding the shear's point of operation during feeding activities at the front of the machine:

- Install a fixed or adjustable point of operation guard at the in-feed of the shearing machine to prevent operator contact with the shear's point of operation as well as the pinch point of the hold-down. The guard's design should prevent the employee from reaching under or around it.
- Install a safety trip control device—such as a pressure-sensitive body bar, safety tripod, or safety tripwire cable—at the in-feed section of the shear.
- Install a presence-sensing device, such as a light curtain, near the in-feed area of a stand-alone automatic or process-line shear.
- Install hold-down devices that prevent the work piece from kicking up and striking the operator.

- Install and arrange two-hand trips and controls so that the operator must use both hands to initiate the shear cycle. Two-hand trips and controls should be designed so they cannot be defeated easily. The ANSI B11.4 *Shears—Safety Requirements for Construction, Care, and Use* standard recommends the installation of additional safeguarding when two-hand controls are used on part-revolution shears, based on the nature of the shearing operation. ANSI specifies the use of guards on full-revolution shears.
- Use restraints for stand-alone manual shears when other guarding methods are not feasible or do not adequately protect employees. These devices may not be appropriate if the job requires employees mobility.
- Install guarded operating stations at a safe distance from the shear's point of operation to prevent inadvertent activation.
- Mount guarded foot pedal controls at a safe distance away from the point of operation to prevent accidental activation.
- Instruct employees to inspect all guarding to ensure that it is in place properly before the machine is operated.
- Instruct supervisors to ensure that operators keep their hands out of the shear's point of operation at all times while the machine is energized and not properly locked out.
- Instruct employees not to perform activities on the back side of a shear while it is operating or still energized.
- Prohibit employees from riding the foot activation pedal.
- Ensure that all operators receive on-the-job training under the direct supervision of experienced operators until they can work safely on their own.
- Require workers to perform servicing and maintenance activities under an energy control program in accordance with 29 *CFR* 1910.147.

The following recommendations apply to safeguarding for operations performed at the rear of the shear:

- Install fixed guards on the back side of shears.
- Install an awareness barrier guard with an interlocking gate, a presence-sensing device (light curtain), or a safety trip control (safety tripwire cable or safety tripod) on the back side of the shear.

Are There Other Controls I Can Implement?

Yes. Here are some work practices and administrative controls for shearing machines you can follow:

- Develop and implement safe operating procedures for shearing machines and conduct periodic inspections to ensure compliance.
- Instruct operators to use distancing tools when their hands might reach into the point of operation because of the size of the material being cut.
- Instruct employees to perform routine maintenance on the clutch and braking systems.

Applicable Standards

- 29 *CFR* 1910.212, *General requirements for all machines.*
- 29 *CFR* 1910.219, *Mechanical power-transmission apparatus.*
- 29 *CFR* 1910.147, *The control of hazardous energy (lockout/tagout).*

Sources of Additional Information

- OSHA Instruction CPL 2-1.24A, *National Emphasis Program on Amputations*
- OSHA publication 3067, *Concepts and Techniques of Machine Safeguarding* (http://www.osha-slc.gov/Publications/Mach_SafeGuard/)
- OSHA Technical Links—Machine Guarding (<http://www.osha-slc.gov/SLTC/machine-guarding/index.html>)
- OSHA Lockout/Tagout Interactive Training Program (<http://www.osha-slc.gov/dts/osta/lototraining/index.htm>)
- ANSI B11.4-1993, *Shears—Safety Requirements for Construction, Care, and Use*

What Are the Hazards Associated with Food Slicers?

Food slicers are electrically powered machines typically equipped with a rotary blade, an on/off switch, thickness adjustment, and a food holder or chute. A pushing/guarding device or plunger may be used to apply pressure to the food against the slicer blade, or pressure may be applied by gravity and/or by an attachment connected to the food holder. (See Figure 37.)

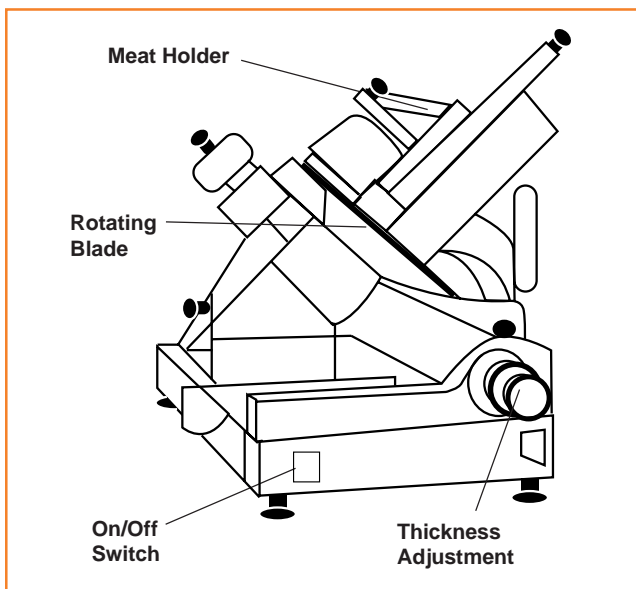

Figure 37. Meat Slicer

Amputations resulting from work with food slicers can occur as follows:

- When the operator adjusts or services the slicer while it is still operating or while it is switched off but still plugged in, or energized. In the latter case, amputations occur when the operator accidentally switches the slicer on.
- When the operator fails to use the sliding attachment on the food-holding device, especially when slicing small pieces of meat.
- When the operator hand-feeds food into a chute-fed slicer without using the proper pushing/guarding device or plunger.

Case History #13

Two employees, an operator and an assistant, were using a meat slicer to slice turkey. The assistant was holding a box of turkey in a tilted position while the operator fed the turkey into the slicer. The operator removed the guard from the meat slicer because the turkey kept jamming. The slicer's knives caught the operator's glove and pulled his hand into the knives, amputating his finger just above the nail.

Case History #14

An employee was cleaning a meat slicer that was turned off but still plugged in. He inadvertently turned the machine on by bumping the on/off switch, resulting in an amputation of his right ring finger.

What Types of Controls Can I Use to Safeguard Slicers?

Some engineering controls you should use include the following:

- Install guards that cover the unused portions of the slicer blade on both the top and bottom of the slicer.
- Buy slicers already equipped with a feeding attachment on the sliding mechanism of the food holder or purchase the attachment separately and install it prior to use.
- Instruct employees to use a pushing/guarding device with chute-fed slicers.
- Provide employees with a plunger for chute-fed slicers that are not equipped with a pushing/guarding device.

Other work practices and administrative controls you can employ for food slicers include appropriate procedures and training. For example, you should do the following:

- Develop and implement safe operating procedures for slicers and conduct periodic inspections to ensure compliance.

36 Identifying Hazards for Specific Types of Machinery

- Ensure that all operators receive on-the-job training under the direct supervision of experienced operators until they can work safely on their own.
- Instruct operators to turn off and unplug slicers when not in use or when left unattended for any period of time.
- Instruct operators to use plungers to feed food into chute-fed slicers. For other slicers, they should use the feeding attachment located on the food-holder. Never place food into the slicer by hand-feeding or hand pressure.
- Tell operators that, although not required, wire mesh gloves may be worn while operating the slicer or cleaning the slicer's blade.
- Instruct operators to retract the slicer blade during cleaning operations.
- Instruct employees to perform servicing and maintenance activities under an energy control program in accordance with 29 *CFR* 1910.147. If the slicer is cord-and-plug connected equipment for which exposure to the hazards of unexpected energization or start up of the equipment is controlled by the unplugging of the equipment from the energy source and by the plug being under the exclusive control of the employee performing the servicing and maintenance, 1910.147 does not apply.

Applicable Standards

- 29 *CFR* 1910.212, *General requirements for all machines.*
- 29 *CFR* 1910.219, *Mechanical power-transmission apparatus.*
- 29 *CFR* 1910.147, *The control of hazardous energy (lockout/tagout).*

Sources of Additional Information

- OSHA publication 3067, *Concepts and Techniques of Machine Safeguarding* (http://www.osha-slc.gov/Publications/Mach_SafeGuard/)
- OSHA Technical Links—Machine Guarding (<http://www.osha-slc.gov/SLTC/machine-guarding/index.html>)
- OSHA Lockout/Tagout Interactive Training Program (<http://www.osha-slc.gov/dts/osta/lototraining/index.htm>)

What Are the Hazards of Using Meat Grinders?

Electrically powered meat grinders typically have a feeding tray attached to a tubular throat, a screw auger that pushes meat to the cutting blade and through the cutting plate, an on/off switch, a reverse switch, and a plunger. (See Figure 38.)

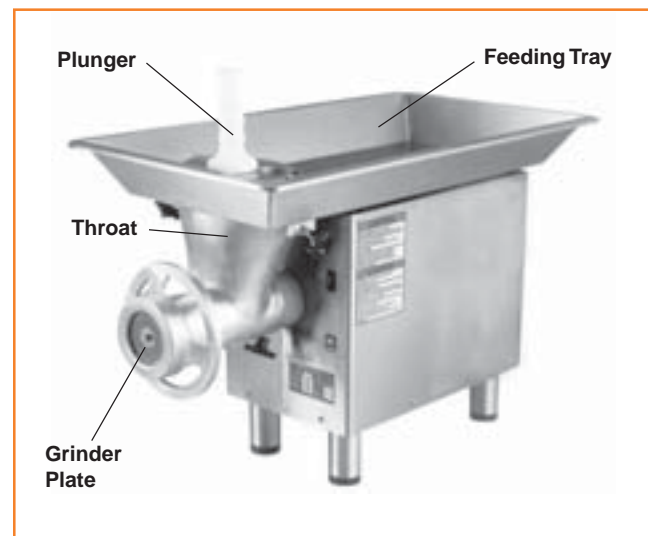

Figure 38. Stainless Steel Meat Grinder

Amputations can occur when:

- The operator reaches into the throat of the grinder while it is still operating or while it is switched off but still plugged in (energized). In the latter case, amputations occur when the operator accidentally switches the grinder back on.

- The operator fails to use the attached feeding tray and throat.

Defective meat grinders, such as ones with holes in the throat or screw auger area, are also a source of workplace amputations and must be taken out of service.

Case History #15

An operator amputated his arm below the elbow while hand-feeding potatoes into a five-horsepower meat grinder through a feed throat with a 4-inch by 6-inch opening and no point of operation guard. This untrained employee had been working on the machine for only 15 minutes.

Case History #16

An employee amputated her hand about 4 inches above the wrist while using an inadequately guarded meat grinder. She had disassembled the grinder to clean it, but did not replace the fixed guard along with stainless steel tray when she reassembled it. Also, she did not use the plunger provided for feeding the meat into the grinder. The machine pulled her hand into the 3-inch diameter auger and amputated it above the wrist.

Source: OSHA IMIS Accident Investigation Database

What Are the Engineering and Other Controls I Can Use to Prevent These Hazards?

In terms of engineering controls, the following are effective:

- Equip meat grinders with properly sized throats that prevent the operator's hands from inadvertently reaching the point of operation.
- Provide operators with properly sized plungers to eliminate the need for their hands to enter the feed throat during operation.

In addition, work practice and administrative controls such as these can help prevent accidents and injuries:

- Develop and implement safe operating procedures for meat grinders to ensure that the guards are adequate and in place, and that the grinder feeding methods are performed safely. Conduct periodic inspections of grinder operations to ensure compliance.
- Ensure that all operators receive appropriate on-the-job training under direct supervision of experienced operators until they can work safely on their own.
- Instruct operators to turn off and unplug grinders when not in use or when left unattended for any period of time.
- Instruct operators to use the proper plunger device to feed meat into grinders. No other device should be used to feed the grinder.
- Instruct employees to operate only grinders with feeding trays and throats installed.
- Instruct operators to use the meat grinder only for its intended purpose.
- Perform appropriate servicing and maintenance activities under an energy control program in accordance with 29 *CFR* 1910.147. If the slicer is a cord and plug connected equipment for which exposure to the hazards of unexpected energization or start up of the equipment is controlled by the unplugging of the equipment from the energy source and by the plug being under the exclusive control of the employee performing the servicing and maintenance, 1910.147 does not apply.

38 Identifying Hazards for Specific Types of Machinery

Applicable Standards

- 29 CFR 1910.212, *General requirements for all machines.*
- 29 CFR 1910.219, *Mechanical power-transmission apparatus.*
- 29 CFR 1910.147, *The control of hazardous energy (lockout/tagout).*

Sources of Additional Information

- OSHA Instruction CPL 2-1.24A, *National Emphasis Program on Amputations*
- OSHA publication 3067, *Concepts and Techniques of Machine Safeguarding* (http://www.osha-slc.gov/Publications/Mach_SafeGuard/)
- OSHA Technical Links—Machine Guarding (<http://www.osha-slc.gov/SLTC/machine-guarding/index.html>)
- OSHA Lockout/Tagout Interactive Training Program (<http://www.osha-slc.gov/dts/osta/lototraining/index.htm>)

How Do Meat-Cutting Band Saws Pose Hazards?

Band saws can cut wood, plastic, metal, or meat. These saws use a thin, flexible, continuous steel strip with cutting teeth on one edge, that runs around two large motorized pulleys or wheels. The blade passes through a hole in the work table where the operator feeds the stock. Blades are available with various teeth sizes, and the saws usually have adjustable blade speeds.

Unlike band saws used in other industries, meat-cutting band saws are usually constructed of stainless steel for sanitary purposes and for easy cleaning. The table, which may slide or roll, has a pushing guard installed to protect the operator while feeding the saw. Meat-cutting band saws may also be equipped with a fence and pushing guard to feed the meat through the band saw. (See Figure 39.)

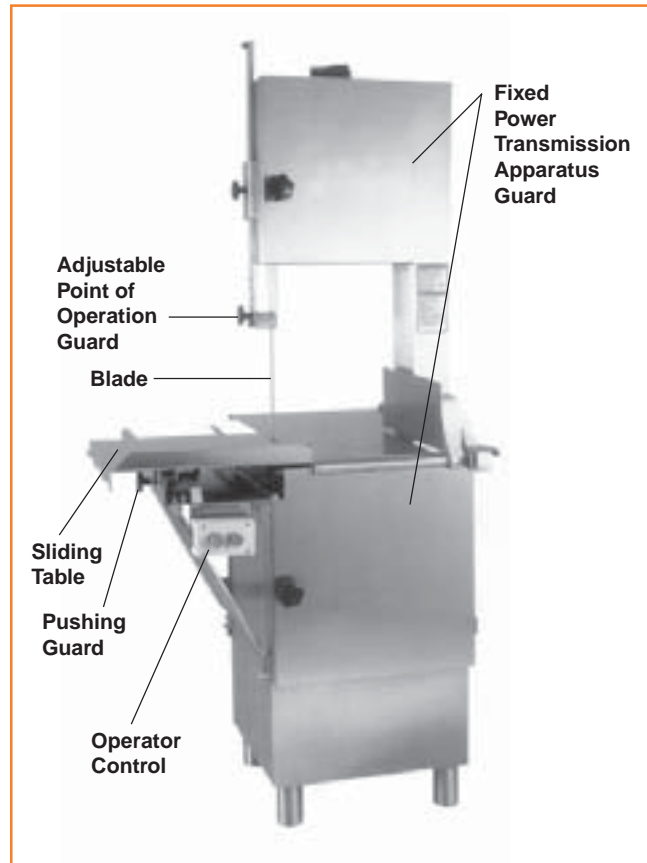

Figure 39. Stainless Steel Meat-Cutting Band Saw

Amputations occur most frequently when operators' hands contact the running saw blade while feeding meat into the saw. The risk of amputation is greatest when operators place their hands too close to the saw blade, in a direct line with the saw blade, or beneath the adjustable guard during feeding operations. Here are some common causes of amputations involving meat-cutting band saws:

- The operator's hand slips off the meat or otherwise accidentally runs through the blade.
- The operator attempts to remove meat from the band saw table while the blade is still moving.
- The operator's gloves, jewelry, or loose-fitting clothing became entangled in the saw blade.

Case History #17

While operating a band saw to cut pork loin, an employee amputated his right index finger when his hand slipped and contacted the moving blade.

Case History #18

An operator amputated the tip of his right ring finger while using a band saw to cut 1/4-inch slabs of meat from a 4-inch thick piece of beef. As the piece of meat got smaller, his hands moved too close to the saw blade. The employee was not using the pusher guard provided for the saw.

Source: OSHA IMIS Accident Investigation Database

What Safeguards Can I Use?

Engineering controls you can use include the following:

- Install a guard over the entire blade, except at the working portion, or point of operation of the blade. The guard must be adjustable to cover the unused portion of the blade above the meat during cutting operations.
- Enclose the pulley mechanism and motor completely.
- Install a brake on one or both wheels to prevent the saw blade from coasting after the machine shut off.
- Provide a pushing guard or fence to feed meat into the saw blade.

The following work practice and administrative controls will help ensure safety in your workplace:

- Develop and implement safe operating procedures for meat-cutting band saws to ensure the guards are adequate and in place and that operators safely perform feeding methods. Conduct periodic inspections of the saw operation to ensure compliance.

- Ensure that all operators receive adequate on-the-job training under the direct supervision of experienced operators until they can work safely on their own.
- Instruct operators to adjust the point of operation guard to admit only the meat.
- Instruct operators to use the pushing guard or fence to feed the saw, especially when cutting small pieces of meat.
- Instruct operators to use only sharp meat-cutting blades and to tighten blades to the appropriate tension.
- Instruct operators not to wear gloves, jewelry, or loose-fitting clothing while operating a band saw and to secure long hair in a net or cap.
- Prohibit operators from removing meat from the band saw while the saw blade is still moving.
- Instruct operators to turn off and unplug band saws when not in use or when left unattended for any period of time.
- Instruct employees to perform servicing and maintenance activities under an energy control program in accordance with 29 *CFR* 1910.147. If the band saw is a cord and plug connected equipment for which exposure to the hazards of unexpected energization or start up of the equipment is controlled by the unplugging of the equipment from the energy source and by the plug being under the exclusive control of the employee performing the servicing and maintenance, 1910.147 does not apply.

40 Identifying Hazards for Specific Types of Machinery

Applicable Standards

- 29 CFR 1910.212, *General requirements for all machines.*
- 29 CFR 1910.213, *Woodworking machinery requirements.*
- 29 CFR 1910.219, *Mechanical power-transmission apparatus.*
- 29 CFR 1910.147, *The control of hazardous energy (lockout/tagout).*

Sources of Additional Information

- OSHA publication 3067, *Concepts and Techniques of Machine Safeguarding* (http://www.osha-slc.gov/Publications/Mach_SafeGuard/)
- OSHA Technical Links—Machine Guarding (<http://www.osha-slc.gov/SLTC/machineguarding/index.html>)
- OSHA Lockout/Tagout Interactive Training Program (<http://www.osha-slc.gov/dts/osta/lototraining/index.htm>)
- OSHA publication 3157, *A Guide for Protecting Workers from Woodworking Hazards*

What About Drill Presses and Related Hazards?

Electrically powered drill presses use a rotating boring bit to drill or cut holes in wood or metal. The holes may be cut to a desired preset depth or completely through the stock. A basic drill press operation consists of selecting an appropriate drill bit, tightening the bit in the chuck, setting the drill depth, placing the material on the drill press bed, securing the work to the bed so that it will not rotate during drilling, turning the drill press on, and pulling the drill press lever down so that the drill bit will be lowered into the stock. (See Figure 40.)

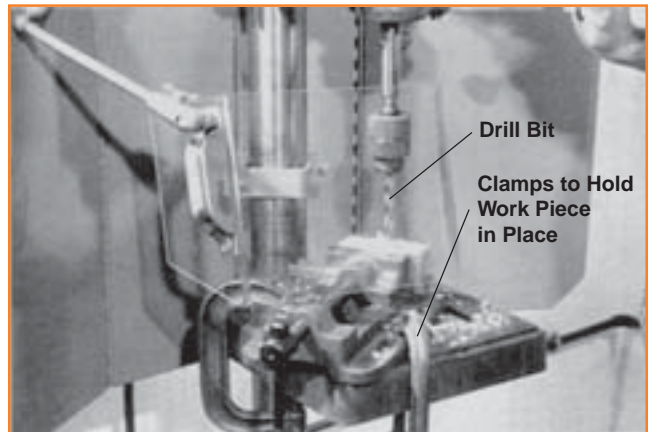

Figure 40. Drill Press with Transparent Drill Shield

Amputations typically occur when the operator's gloves, loose-fitting clothing, or jewelry become entangled in the rotating drill bit. Here are some other causes of drill press-related amputations:

- Inadequately guarding points of operation or power-transmission devices.
- Performing servicing and maintenance activities such as changing pulleys and belts, changing or tightening drill bits, lubricating the drill press, and cleaning the drill press without de-energizing the drill press.
- Making adjustments to the drill press such as setting the depth, securing the material to the drill press bed, and repositioning the wood or metal while the drill bit is still rotating.

Case History #19

A mechanic amputated the first joints of his left index and middle fingers while changing the belt position on a multi-pulley drill press. While the mechanic was pulling the belt on, it suddenly went around the outside pulley, pulling the mechanic's fingers through the nip point.

Case History #20

A machinist amputated his left index finger at the first joint while drilling holes into a machined part. As he moved the part to begin drilling another hole, his gloved hand got caught in the drill bit.

Source: OSHA IMIS Accident Investigation Database

What Are Some Methods for Safeguarding Drill Presses?

For drill presses, you can install guards and other controls and perform work practices:

- Install guarding over the motor, belts, and pulleys.
- Install an adjustable guard to cover the unused portion of the bit and chuck above the material being worked.
- Replace projecting chucks and set screws with non-projecting safety-bit chucks and set screws.
- Cover operator controls so that the drill press cannot be turned on accidentally.
- Develop and implement safe work practices for drill-press operations and conduct periodic inspections to ensure compliance.
- Train and supervise all operators until they can work safely on their own.
- Instruct employees not to wear gloves, jewelry, or loose-fitting clothing while operating a drill press and to secure long hair in a net or cap.
- Make sure operators secure material to the drill press bed with clamps before drilling, so that the material will not spin and strike the operator. The operator should not manually secure the work to the drill press bed while drilling holes.
- Do not adjust the drill press while the drill bit is still rotating.
- Use the drill press only for its intended purposes.
- Shut off the drill press when not in use or when left unattended for any period of time.
- Remove the chuck immediately after each use.

- Perform appropriate servicing and maintenance activities under an energy control program in accordance with 29 *CFR* 1910.147.

Applicable Standards

- 29 *CFR* 1910.212, *General requirements for all machines.*
- 29 *CFR* 1910.213, *Woodworking machinery requirements.*
- 29 *CFR* 1910.219, *Mechanical power-transmission apparatus.*
- 29 *CFR* 1910.147, *The control of hazardous energy (lockout/tagout).*

Sources of Additional Information

- OSHA publication 3067, *Concepts and Techniques of Machine Safeguarding* (http://www.osha-slc.gov/Publications/Mach_SafeGuard/)
- OSHA Technical Links—Machine Guarding (<http://www.osha-slc.gov/SLTC/machine-guarding/index.html>)
- OSHA Lockout/Tagout Interactive Training Program (<http://www.osha-slc.gov/dts/osta/lototraining/index.htm>)
- OSHA publication 3157, *A Guide for Protecting Workers from Woodworking Hazards*

What About Milling Machines and Related Hazards?

Electrically powered milling machines cut metal using a rotating cutting device called a milling cutter. These machines cut flat surfaces, angles, slots, grooves, shoulders, inclined surfaces, dovetails, and recessed cuts. Cutters of different sizes and shapes are available for a wide variety of milling operations.

Milling machines include knee-and-column machines, bed-type or manufacturing machines, and special milling machines designed for special applications. Typical milling operations consist of

42 Identifying Hazards for Specific Types of Machinery

selecting and installing the appropriate milling cutter, loading a work piece on the milling table, controlling the table movement to feed the part against the rotating milling cutter, and calipering or measuring the part. (See Figure 41.)

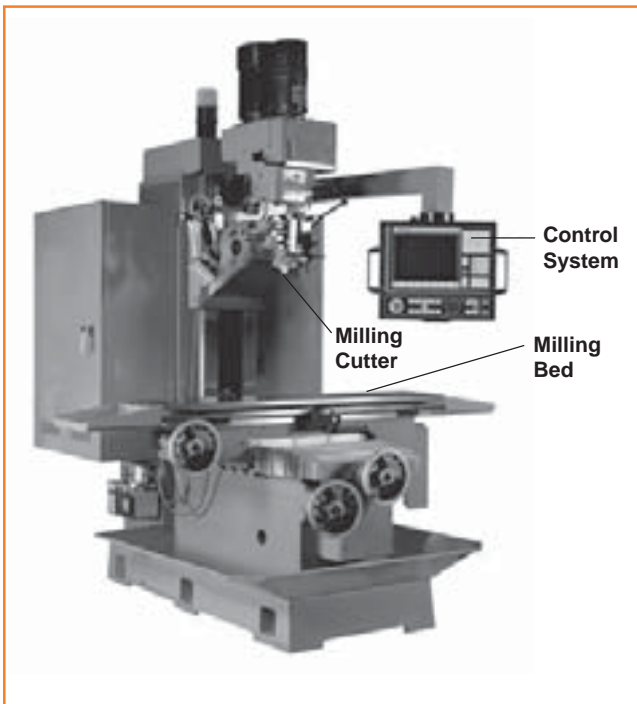

Figure 41. Bed Mill

There are some frequent causes of amputation from milling machines:

- Loading or unloading parts and calipering or measuring the milled part while the cutter is still rotating.
- Performing servicing and maintenance activities such as setting up the machine, changing and lubricating parts, clearing jams, and removing excess oil, chips, fines, turnings, or particles while the milling machine is either stopped but still energized, or while the cutter is still rotating.
- Getting jewelry or loose-fitting clothing entangled in the rotating cutter.

Case History #21

While replacing parts on a horizontal milling machine, an employee shut off the machine, which put the revolving cutter in a neutral position. The employee, however, did not disengage the clutch to stop the cutter and proceeded to replace parts while the cutter was still moving. He amputated three fingers.

Case History #22

An employee was using a milling machine to cut metal samples to length. After a part had been cut, the employee needed to gauge the part size. While he was checking the edge of the sample, the blade caught the tip of his glove, pulled his hand into the cutting area, and amputated his right ring finger and part of his middle finger.

Source: OSHA IMIS Accident Investigation Database

What Are Some Milling Machine Safeguarding Methods?

You should implement the following engineering, work practices, and administrative controls:

- Install self-closing guards that enclose the milling cutter when the table has been withdrawn.
- Install an interlocked barrier guard around the table. When equipped with a cutter blade brake, the brake should be applied when opening or removing the interlocked barrier guard.
- Use other safeguarding devices such as splash shields, chip shields, or barriers if they provide effective protection to the operator and when it is impractical to guard cutters without interfering with normal production operations or creating a more hazardous situation.
- Instruct operators not to use a jib or vise that prevents the point of operation guard from being adjusted appropriately.

- Develop and implement safe work practices for machine operators and conduct periodic inspections to ensure compliance.
- Ensure that all operators receive appropriate on-the-job training by experienced operators until they can work safely on their own.
- Instruct operators to move the work holding device back to a safe distance when loading or unloading parts and calipering or measuring the work and not to perform these activities while the cutter is still rotating unless the cutter is adequately guarded.
- Prohibit operators from reaching around the cutter or hob to remove chips while the machine is in motion or not de-energized.
- Instruct operators to remove fines, turnings, or particles only with a brush while the cutter is stopped.
- Instruct operators to place the jib or vise locking arrangement so that force must be exerted away from the milling cutter.
- Instruct operators not to leave the cutter exposed after withdrawing work piece.
- Instruct operators to turn off the milling machine when not in use or when left unattended for any period of time.
- Instruct employees not to wear gloves, jewelry, or loose-fitting clothing while operating a milling machine and to secure long hair in a net or cap.

Applicable Standards

- 29 CFR 1910.212, *General requirements for all machines.*
- 29 CFR 1910.219, *Mechanical power-transmission apparatus.*
- 29 CFR 1910.147, *The control of hazardous energy (lockout/tagout).*

Sources of Additional Information

- OSHA publication 3067 *Concepts and Techniques of Machine Safeguarding* (http://www.osha-slc.gov/Publications/Mach_SafeGuard/)
- OSHA Technical Links—Machine Guarding (http://www.osha-slc.gov/SLTC/machine_guarding/index.html)
- OSHA Lockout/Tagout Interactive Training Program (<http://www.osha-slc.gov/dts/osta/lototraining/index.htm>)
- National Safety Council, *Accident Prevention Manual for Industrial Operations: Engineering and Technology*. 10th. Ed. Itasca, IL

- Instruct operators to perform servicing and maintenance activities under an energy control program in accordance with 29 CFR 1910.147.

What Are the Hazards of Working with Grinding Machines?

Grinding machines primarily alter the size, shape, and surface finish of metal by placing a workpiece against a rotating abrasive surface or wheel. Grinding machines may also be used for grinding glass, ceramics, plastics, and rubber.

Examples of grinding machines include abrasive belt machines, abrasive cutoff machines, cylindrical grinders, centerless grinders, gear grinders, internal grinders, lapping machines, offhand grinders, surface grinders, swing frame grinders, and thread grinders. (See Figure 42.)

Amputation injuries occur when the operator's hands enter the point of operation during the following activities:

- Grinding on the side of the wheel not designed for grinding.
- Using an inadequately guarded grinding wheel.
- Using an incorrectly adjusted or missing work rest or a poorly maintained or unbalanced abrasive wheel.

44 Identifying Hazards for Specific Types of Machinery

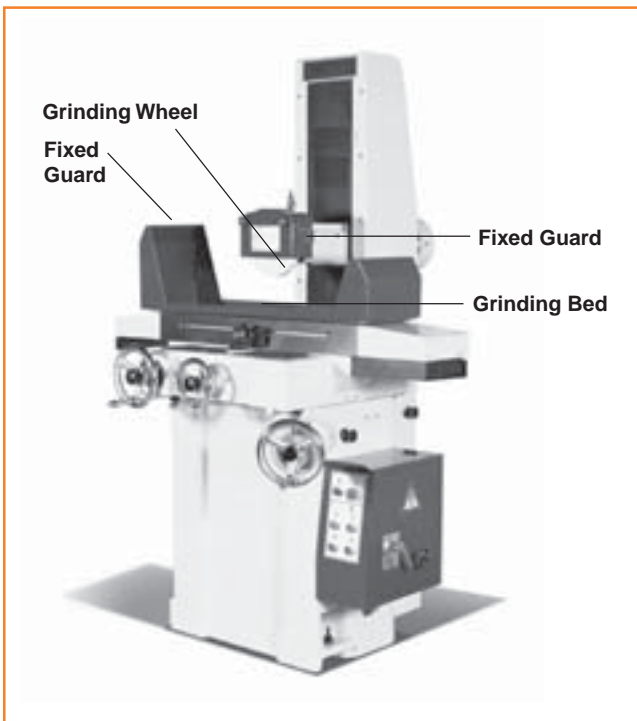

Figure 42. Horizontal Surface Grinder

- Wedging a tool between the work rest and the abrasive wheel, causing the wheel to break into flying particles.
- Adjusting the work rest, balancing the wheel, cleaning the area around the abrasive wheel, attempting to stop a rotating abrasive wheel by hand, and loading and unloading parts or measuring parts while the abrasive wheel is still rotating.

Case History #23

After grinding a piece of steel on an offhand grinder, an employee turned off the machine and tried to stop the wheel with a piece of scrap steel. His hand slipped and hit the rotating abrasive wheel, amputating the tip of his left middle finger.

Case History #24

An employee was operating a large surface grinder to grind a groove into a steel part in a large pump repair shop. The part was secured with a vise and placed on a magnetic table. The employee was trying to measure the groove while the table was moving back and forth beneath the grinding wheel. The safe practice, both written and customary, is to disengage the hydraulics for the table and stop the wheel before reaching in to measure or remove a part. Though experienced at operating this machine and aware of the strict rule, the employee attempted to take measurements while the table and wheel were moving and ground off part of his left index finger.

How Can I Safeguard Grinding Machines?

You can help prevent worker accidents and injuries by using guards and other engineering controls. Here are some examples:

- Install safety guards that cover the spindle end, nut, and flange projections or otherwise ensure adequate operator protection.
- Install adjustable and rigid work rests on off-hand grinding machines.
- Install guards on foot-operated controls to prevent accidental activation.
- Instruct operators to use hand tools to maintain a safe distance between the operator and the point of operation when needed.

Work practices and administrative controls also are important. Here are some recommended ways to safeguard grinding machines by using the following controls:

- Develop and implement safe work practices for grinding machine operations and conduct periodic inspections to ensure compliance.

- Ensure that all operators receive appropriate on-the-job training and supervision until they can work safely on their own.
- Instruct operators to inspect the grinding wheel to ensure that it is not defective, unbalanced, loose, or too small.
- Instruct operators to inspect the point of operation guard and to adjust it if necessary prior to each use.
- Instruct operators to adjust the work rest to within 1/8 inch from the wheel.
- Instruct employees not to wear gloves, jewelry, or loose-fitting clothing while operating grinding machines and to secure long hair in a net or cap.
- Instruct employees to keep their hands as far away as possible from the point of operation while feeding work into an offhand grinder.
- Instruct employees not to adjust the guard or clean the grinding machine while the abrasive wheel is still rotating.
- Instruct employees to perform servicing and maintenance activities under an energy control program in accordance with 29 CFR 1910.147.

Applicable Standards

- 29 CFR 1910.215, *Abrasive wheel machinery.*
- ANSI B7.1-70, *Safety Code for the Use, Care and Protection of Abrasive Wheels* [incorporated by reference in 1910.215(b)(12)]
- 29 CFR 1926.303, *Abrasive wheels and tools.*
- 29 CFR 1910.219, *Mechanical power-transmission apparatus.*
- 29 CFR 1910.147, *The control of hazardous energy (lockout/tagout).*

Sources of Additional Information

- OSHA publication 3067, *Concepts and Techniques of Machine Safeguarding* (http://www.osha-slc.gov/Publications/Mach_SafeGuard/)
- OSHA Technical Links—Machine Guarding (<http://www.osha-slc.gov/SLTC/machine-guarding/index.html>)
- OSHA Lockout/Tagout Interactive Training Program (<http://www.osha-slc.gov/dts/osta/lototraining/index.htm>)
- ANSI B7.1—2000, *Use, Care, and Protection of Abrasive Wheels*
- ANSI B11.9—1975 (R1997), *Grinding Machines, Safety Requirements for the Construction, Care, and Use of*
- ANSI B5.37—1970 (R1994), *External Cylindrical Grinding Machines—Centerless*
- ANSI B5.42—1981 (R1994), *External Cylindrical Grinding Machines—Universal*

What Are the Hazards from Slitters?

Slitters use rotary knives to slit flat rolled metal, plastic film, paper, plastic, foam, and rubber as well as other coiled or sheet fed materials. Slitters range from small hand-fed paper slitters to large-scale automated metal slitters, complete with metal processing and handling units such as unwinders and rewinders. Both light and heavy gage slitters are available. (See Figure 43.)

Amputations often occur when clothing or body parts come in contact with slitter blades or get caught in the movement of coils and rolls. Here are some examples:

- Workers can inadvertently get their fingers and hands caught in the in-going nip points of the slitter or associated machinery such as rewinders.
- Gloves, jewelry, and loose clothing can get entangled in in-going nip points or in the rotary knives of the slitter.

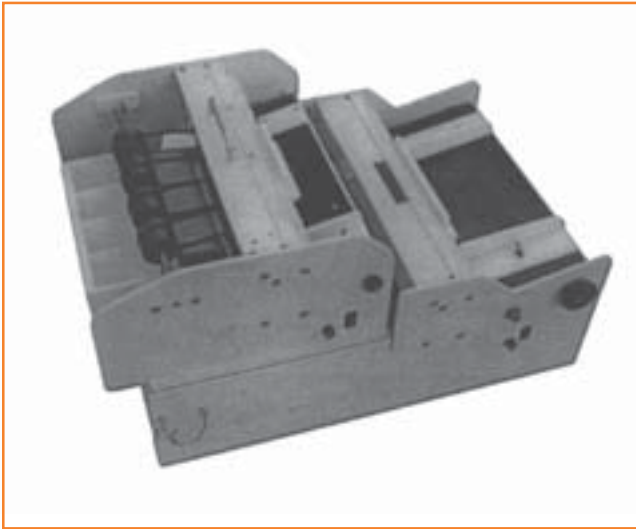

Figure 43. Paper Slitter

- Workers can suffer an amputation when clearing, adjusting, cleaning, or servicing the slitter while it is either still operating, or shut off but still plugged in (energized).

Case History #25

An employee was operating a precision slitting machine to slit a roll of aluminum. As the employee reached into the machine to make an adjustment because the aluminum was not being slit properly, the employee's right arm got caught in the slitter. A set of rollers pulled his arm and amputated his right thumb and forefinger.

Case History #26

An employee was feeding cardboard strips onto slit steel as it was being coiled on a slitter machine. While the machine was operating, the employee was placing the cardboard strips on the coils. After reaching over the steel strips, the coiled steel on the mandrel pulled his right arm into the machine and amputated it.

What Are Some Ways to Safeguard Slitter Machines?

You can use guards and other engineering controls such as the following:

- Install a fixed or adjustable point of operation guard at the in-feed and out-feed section of the machine.
- Install a fixed point of operation guard to cover the sides of the unwinder/rewinder to prevent an employee's hands or clothing from entering into the rollers.
- Install fixed or interlocked guards to cover other moving parts of the machine such as the power-transmission apparatus.
- Use an awareness barrier guard with an interlocking gate around the perimeter of the machine to prevent unauthorized entry.
- Provide guards for operator control stations to prevent inadvertent activation.

You can also implement work practices and administrative controls to help do the following:

- Develop and implement safe work procedures for machine operators and conduct periodic inspections to ensure compliance.
- Ensure that all operators receive appropriate on-the-job training and supervision until they can work safely on their own.
- Instruct employees to perform servicing and maintenance activities under an energy control program in accordance with 29 *CFR* 1910.147.

Applicable Standards

- 29 CFR 1910.212, *General requirements for all machines.*
- 29 CFR 1910.219, *Mechanical power-transmission apparatus.*
- 29 CFR 1910.147, *The control of hazardous energy (lockout/tagout).*

Sources of Additional Information

- OSHA publication 3067 *Concepts and Techniques of Machine Safeguarding* (http://www.osha-slc.gov/Publications/Mach_SafeGuard/)
- OSHA Technical Links—Machine Guarding (http://www.osha-slc.gov/SLTC/machine_guarding/index.html)
- OSHA Lockout/Tagout Interactive Training Program (<http://www.osha-slc.gov/dts/osta/lototraining/index.htm>)

OSHA can provide extensive help through a variety of programs, including assistance about safety and health programs, state plans, workplace consultations, voluntary protection programs, strategic partnerships, and training and education, and more.

Safety and Health Program Management Guidelines

Effective management of worker safety and health protection is a decisive factor in reducing the extent and severity of work-related injuries and illnesses and their related costs. In fact, an effective safety and health program forms the basis of good worker protection and can save time and money—about \$4 for every dollar spent—and increase productivity.

To assist employers and employees in developing effective safety and health programs, OSHA published recommended *Safety and Health Program Management Guidelines* (*Federal Register* 54(16): 3904-3916, January 26, 1989). These voluntary guidelines can be applied to all places of employment covered by OSHA.

The guidelines identify four general elements that are critical to the development of a successful safety and health management system:

- Management leadership and employee involvement,
- Worksite analysis,
- Hazard prevention and control, and
- Safety and health training.

The guidelines recommend specific actions, under each of these general elements, to achieve an effective safety and health management system. *The Federal Register* notice is available online at www.osha.gov

State Programs

The *Occupational Safety and Health Act of 1970* (*OSH Act*) encourages states to develop and operate their own job safety and health plans. OSHA approves and monitors these plans. There are currently 26 state plans: 23 cover both private and

public (state and local government) employment; 3 states, Connecticut, New Jersey, and New York, cover the public sector only. States and territories with their own OSHA-approved occupational safety and health plans must adopt and enforce standards identical to, or at least as effective as, the federal standards and provide extensive programs of voluntary compliance and technical assistance, including consultation services.

Consultation Services

Consultation assistance is available on request to employers who want help in establishing and maintaining a safe and healthful workplace. Largely funded by OSHA, the service is provided at no cost to the employer. Primarily developed for smaller employers with more hazardous operations, the consultation service is delivered by state governments employing professional safety and health consultants. Comprehensive assistance includes an appraisal of all aspects of the employer's existing safety and health management system. In addition, the service can help employees in developing and implementing an effective safety and health management system. No penalties are proposed or citations issued for hazards identified by the consultant. OSHA provides consultation assistance to the employer with the assurance that his or her name and firm and any information about the workplace will not be routinely reported to OSHA enforcement staff.

Under the consultation program, certain exemplary employers may request participation in OSHA's Safety and Health Achievement Recognition Program (SHARP). Eligibility for participation in SHARP includes, but is not limited to, receiving a full service, comprehensive consultation visit, correcting all identified hazards, and developing an effective safety and health program management system.

Employers accepted into SHARP may receive an exemption from programmed inspections (not complaint or accident investigation inspections) for a period of 1 year initially, or 2 years upon renewal. For more information concerning consultation assistance, see the list of consultation projects listed at the end of this publication. For more information concerning consultation assistance, see the list of

consultation projects listed at the end of this publication.

Voluntary Protection Program (VPP)

Voluntary Protection Programs and onsite consultation services, when coupled with an effective enforcement program, expand worker protection to help meet the goals of the *OSH Act*. The three VPPs—Star, Merit, and Demonstration—are designed to recognize outstanding achievements by companies that have developed and implemented effective safety and health management systems. The VPPs motivate others to achieve excellent safety and health results in the same outstanding way as they establish a cooperative relationship between employers, employees, and OSHA.

For additional information on VPPs and how to apply, contact the OSHA regional offices listed at the end of this publication.

Strategic Partnership Program

OSHA's Strategic Partnership Program, the newest member of OSHA's cooperative programs, helps encourage, assist, and recognize the efforts of partners to eliminate serious workplace hazards and achieve a high level of worker safety and health. Whereas OSHA's Consultation Program and VPP entail one-on-one relationships between OSHA and individual worksites, most strategic partnerships seek to have a broader impact by building cooperative relationships with groups of employers and employees. These partnerships are voluntary, cooperative relationships between OSHA, employers, employee representatives, and others (e.g., trade unions, trade and professional associations, universities, and other government agencies).

For more information on this program, contact your nearest OSHA office, or visit OSHA's website at www.osha.gov.

Training and Education

OSHA's area offices offer a variety of information services, such as compliance assistance, technical advice, publications, audiovisual aids and speakers for special engagements. OSHA's Training Institute in Des Plaines, IL, provides basic and advanced courses in safety and health for federal and state compliance officers, state consultants,

federal agency personnel, and private sector employers, employees, and their representatives.

The OSHA Training Institute also has established OSHA Training Institute Education Centers to address the increased demand for its courses from the private sector and from other federal agencies. These centers are nonprofit colleges, universities, and other organizations that have been selected after a competition for participation in the program.

OSHA awards grants through its Susan Harwood Training Grant Program to nonprofit organizations to provide safety and health training and education to employers and workers in the workplace. The grants focus on programs that will educate workers and employers in small business (fewer than 250 employees), training workers and employers about new OSHA standards or about high-risk activities or hazards. Grants are awarded for 1 year and may be renewed for an additional 12-month period depending on whether the grantee has performed satisfactorily.

OSHA expects each organization awarded a grant to develop a training and/or education program that addresses a safety and health topic named by OSHA, recruit workers and employers for the training, and conduct the training. Grantees are also expected to follow up with people who have been trained to find out what changes were made to reduce the hazards in their workplaces as a result of the training.

Each year OSHA has a national competition that is announced in the *Federal Register* and on the Internet at <http://www.osha-slc.gov/Training/sharwood/sharwood.html>. For more information on grants, training, and education, contact the OSHA Training Institute, Office of Training and Education, 1555 Times Drive, Des Plaines, IL 60018, (847) 297-4810.

Electronic Information

OSHA has a variety of materials and tools available on its website—www.osha.gov. These include *e-Tools*, *Expert Advisors*, *Electronic Compliance Assistance Tools (e-CATs)*, *Technical Links*, regulations, directives, publications, videos, and

other information for employers and employees. OSHA's software programs and compliance assistance tools walk you through challenging safety and health issues and common problems to find the best solutions for your workplace.

OSHA's CD-ROM includes standards, interpretations, directives, and more and can be purchased on CD-ROM from the U.S. Government Printing Office. To order, write to the Superintendent of Documents, P.O. Box 371954, Pittsburgh, PA 15250-7954 or phone (202) 512-1800. Specify OSHA Regulations, Documents and Technical Information on CD-ROM (ORDT), GPO Order No. S/N 729-013-00000-5. The price is \$45 per year (\$56.25 foreign); \$21 per single copy (\$26.25 foreign).

OSHA Publications

OSHA has an extensive publications program. For a listing of free or sales items, visit OSHA's website at www.osha.gov or contact the OSHA Publications Office, U.S. Department of Labor, OSHA/OSHA Publications, P.O. Box 37535, Washington, DC 20013-7535. Telephone (202) 693-1888 or fax to (202) 693-2498.

Emergencies, Complaints, and Further Assistance

To report an emergency, file a complaint, or seek OSHA advice, assistance, or products, call 1-800-321-OSHA or contact your nearest OSHA regional or area office listed at the end of this publication. The teletypewriter (TTY) number is 1-877-889-5627.

You can also file a complaint online and obtain more information on OSHA federal and state programs by visiting OSHA's website at www.osha.gov.

American National Standards Institute

- ANSI B5.52M-1980 (R1994), *Presses, General Purpose, Single Point, Gap Type, Mechanical Power (Metric)*
- ANSI B5.37—1970 (R1994), *External Cylindrical Grinding Machines—Centerless*
- ANSI B5.42—198 (R1994), *External Cylindrical Grinding Machines—Universal*
- ANSI B7.1—2000, *Use, Care, and Protection of Abrasive Wheels*
- ANSI B11.1-1988 (R1994), *Machine Tools—Mechanical Power Presses, Safety Requirement for Construction, Care, and Use*
- ANSI B11.3-1982 (R1994), *Power Press Brakes, Safety Requirements for the Construction, Care, and Use of*
- ANSI B11.9—1975 (R1997), *Grinding Machines, Safety Requirements for the Construction, Care, and Use of*
- ANSI B11.12-1996 *Roll-Forming and Roll-Bending Machines—Safety Requirements for Construction, Care, and Use*
- ANSI B11.4-1993, *Shears—Safety Requirements for Construction, Care, and Use*
- ANSI B20.1-57, *Safety Code for Conveyors, Cableways, and Related Equipment* [incorporated by reference in 1926.555 (a)(8)]
- ANSI B65.1-1995, *Safety Standard—Printing Press Systems*

**American National Standards Institute/
Conveyor Equipment
Manufacturers Association**

- ANSI/CEMA 401-1994, *Unit Handling Conveyors—Roller Conveyors—Non-powered*
- ANSI/CEMA 402-1992, *Unit Handling Conveyors—Belt Conveyors*
- ANSI/CEMA 403-1985, *Unit Handling Conveyors—Belt Driven Live Roller Conveyors*

**American National Standards Institute/
American Society of Mechanical Engineers**

- ANSI/ASME B20.1-1996, *Safety Standard for Conveyors and Related Equipment*

**National Institute for Occupational Safety
and Health**

- NIOSH CIB 49, *Injuries and Amputations Resulting from Work with Mechanical Power Presses* (May 22, 1987)

National Safety Council

- National Safety Council, *Accident Prevention Manual for Industrial Operations: Engineering and Technology*. 9th. Ed. Itasca, IL
- National Safety Council, *Accident Prevention Manual for Business and Industry: Engineering and Technology* 11th Ed. Itasca, IL

**Occupational Safety and Health
Administration Standards**

- 29 CFR 1910.147—*The control of hazardous energy (lockout/tagout)*.
- 29 CFR 1910.211—*Definitions*.
- 29 CFR 1910.212—*General requirements for all machines*.
- 29 CFR 1910.213—*Woodworking machinery requirements*.
- 29 CFR 1910.215—*Abrasive wheel machinery*.
- 29 CFR 1910.217—*Mechanical power presses*.
- 29 CFR 1910.219—*Mechanical power-transmission apparatus*.
- 29 CFR 1926.300—*General requirements*.
- 29 CFR 1926.301—*Hand tools*.
- 29 CFR 1926.302—*Power-operated hand tools*.
- 29 CFR 1926.303—*Abrasive wheels and tools*.
- 29 CFR 1926.304—*Woodworking tools*.
- 29 CFR 1926.307—*Mechanical power—transmission apparatus*.
- 29 CFR 1926.555—*Conveyors*.

Occupational Safety and Health

Administration Instructions

- OSHA Instruction CPL 2-1.24A, *National Emphasis Program on Amputations*
- OSHA Instruction STD 1-12.21—29 CFR 1910.217, *Mechanical Power Presses, Clarifications* (10/30/78)
- OSHA Directive— CPL 2-1.25, *Guidelines for Point of Operation Guarding of Power Press Brakes*
- OSHA Directive STD 1-7.3, *The Control of Hazardous Energy (Lockout/Tagout)—Inspection Procedures and Interpretive Guidance*

Occupational Safety and Health

Administration Interpretations

- OSHA Interpretation - 1910.212, *Point of Operation Guarding on Power Press Brakes* (03/25/1983)

Occupational Safety and Health

Administration Training Programs

- OSHA's Lockout Tagout Interactive Training Program (<http://www.osha-slc.gov/dts/osta/lototraining/index.htm>)

Occupational Safety and Health

Administration Publications

- OSHA Publication 3067- *Concepts and Techniques of Machine Safeguarding* (http://www.osha-slc.gov/Publications/Mach_SafeGuard/)
- OSHA Publication 3120- *Control of Hazardous Energy (Lockout/Tagout)*
- OSHA publication 3157- *A Guide for Protecting Workers from Woodworking Hazards*

Occupational Safety and Health

Administration Technical Links

- OSHA Technical Links—Machine Guarding (<http://www.osha-slc.gov/SLTC/machineguarding/index.html>)

The following amputation hazards and related activities are not covered in detail in this document. They are either covered in other OSHA publications or specific OSHA standards. While you may find the general hazard recognition and machine guarding concepts presented in the ***Recognizing Amputations Hazards and Controlling Amputation Hazards*** sections of this document helpful, please refer to the applicable topic-specific resources and standards listed in the reference section of this publication for a complete discussion of these hazards.

Amputation Hazards Associated with Saws

Saws are the top source of amputations in wholesale and retail trade and in the construction industry. Table saws, radial arm saws, and band saws are the primary stationary saws responsible for saw-related amputations in the workplace. Sawing machinery used for woodworking applications is not specifically addressed in this guide. You can find specific guidance on these saws in OSHA Publication 3157, *A Guide for Protecting Workers From Woodworking Hazards*; 29 CFR 1910.213, *Woodworking machinery requirements*; 29 CFR 1910.243, *Guarding of portable powered tools*; and 29 CFR 1926.304, *Woodworking tools*.

Amputation Hazards Associated with Machine Servicing and Maintenance

Most machine servicing and maintenance amputations occur when workers failed to render safe all potentially hazardous energy before starting work or do not properly apply lockout/tagout devices to a machine's energy control devices. Servicing and maintenance activities associated with amputations include setting up machines for production operations, bypassing guards to clear jams, and replacing or servicing machine parts. OSHA's Lockout/Tagout standard (29 CFR 1910.147) and the sources listed below contain further information.

For detailed information about lockout/tagout see the following publications:

- OSHA Directive STD 1-7.3, *The Control of Hazardous Energy (Lockout/Tagout)—Inspection Procedures and Interpretive Guidance*
- OSHA's Lockout Tagout Interactive Training Program (<http://www.osha-slc.gov/dts/osta/lototraining/index.htm>)
- OSHA Publication 3120, *Control of Hazardous Energy (Lockout/Tagout)*

Amputation Hazards in Agriculture and Maritime Operations

Requirements for machine guarding in agriculture operations are contained in the Standards for Agriculture, 29 CFR Part 1928 Subpart D—*Safety for Agricultural Equipment*, and requirements for machine guarding in maritime operations can be found in the Shipyard Employment Standards, 29 CFR Part 1915 Subpart H—*Tools and Related Equipment*, the Marine Terminals Standard, 29 CFR Part 1917 Subpart G—*Machine Guarding*, and the Longshoring Standard, 29 CFR Part 1918 Subpart I—*General Working Conditions*.

Additional Health and Safety Hazards

Other health and safety hazards associated with using stationary machines, but not addressed in this guide, include noise, vibration, ergonomic stresses, exposure to hazardous chemicals (e.g. metalworking fluids) and dust, electric hazards, and flying objects.

Please visit the OSHA website at www.osha.gov for more information on how to recognize and control these hazards.

Although stationary machines are associated with amputations more frequently than any other source, amputations can result from other sources. This appendix briefly identifies other equipment and activities associated with amputations:

- **Powered and Non-Powered Hand Tools.** Portable hand tools such as saws, grinders, shears, and bolt cutters, are associated with amputations in the construction, retail trade, and services industries.
- **Material Handling.** Amputations related to manual material handling tasks often result when heavy or sharp objects fall from an elevated surface or shift during transfer. Amputation often occurs when the employee attempts to limit the movement of, or damage to, material as it shifts or falls.
- **Forklifts.** Amputation hazards related to forklift operation and use include employees being trapped or pinned between the forklift and another object; struck or run over by the forklift; struck by falling or shifting loads or overturning forklifts.
- **Doors and Covers.** Amputation hazards are not limited to mechanical equipment or heavy loads. Doors also have the potential to amputate fingers. These injuries typically result when a door closes while a person's hands are in the door jamb. Manhole covers, commercial garbage disposal covers, and tank or bin covers can also amputate fingers and toes.
- **Trash Compactors.** Many businesses use small trash compactors for reducing the volume of wastes such as cardboard. Often these compactors are not properly guarded and employees are not properly trained in their use. The majority of these amputations result from employees being struck by the ram/piston either during the initiating stroke or the return stroke. The ram/piston should be guarded if any part of an operator's body is exposed to the danger area during the operating cycle. Likewise, before reaching into any trash compactor the operator should deenergize and lock out the machine.

OSHA Regional Offices**REGION I**

(CT,* ME, MA, NH, RI, VT*)
JFK Federal Building, Room E340
Boston, MA 02203
(617) 565-9860

REGION II

(NJ,* PR,* VI*)
201 Varick Street, Room 670
New York, NY 10014
(212) 337-2378

REGION III

(DE, DC, MD,* PA,* VA,* WV)
The Curtis Center
170 S. Independence Mall West
Suite 740 West
Philadelphia, PA 19106-3309
(215) 861-4900

REGION IV

(AL, FL, GA, KY,* MS, NC,* SC,* TN*)
Atlanta Federal Center
61 Forsyth Street, SW, Room 6T50
Atlanta, GA 30303
(404) 562-2300

REGION V

(IL, IN,* MI,* MN,* OH, WI)
230 South Dearborn Street, Room 3244
Chicago, IL 60604
(312) 353-2220

REGION VI

(AR, LA, NM,* OK, TX)
525 Griffin Street, Room 602
Dallas, TX 75202
(214) 767-4731 or 4736 x22

REGION VII

(IA,* KS, MO, NE)
City Center Square
1100 Main Street, Suite 800
Kansas City, MO 64105
(816) 426-5861

REGION VIII

(CO, MT, ND, SD, UT,* WY*)
1999 Broadway, Suite 1690
Denver, CO 80202-5716
(303) 844-1600

REGION IX

(American Samoa, AZ,* CA,* HI, NV,*
Northern Mariana Islands)
71 Stevenson Street, Room 420
San Francisco, CA 94105
(415) 975-4310

REGION X

(AK,* ID, OR,* WA*)
1111 Third Avenue, Suite 715
Seattle, WA 98101-3212
(206) 553-5930

*These states and territories operate their own OSHA-approved job safety and health programs (Connecticut, New Jersey, and New York plans cover public employees only). States with approved programs must have a standard that is identical to, or at least as effective as, the federal standard.

OSHA Area Offices

U.S. Department of Labor - OSHA
Vestavia Village, 2047 Canyon Road
Birmingham, AL 35216-1981
(205) 731-1534

U.S. Department of Labor - OSHA
3737 Government Boulevard, Suite 100
Mobile, AL 36693-4309
(334) 441-6131

U.S. Department of Labor - OSHA
301 W. Northern Lights Blvd, Suite 407
Anchorage, AK 99503-7571
(907) 271-5152

U.S. Department of Labor - OSHA
TCBY Building, Suite 450
425 West Capitol Avenue
Little Rock, AR 72201
(501) 324-6291(5818)

U.S. Department of Labor - OSHA
3221 North 16th Street, Suite 100
Phoenix, AZ 85016
(602) 640-2348

U.S. Department of Labor - OSHA
5675 Ruffin Road, Suite 330
San Diego, CA 92123
(619) 557-5909

U.S. Department of Labor - OSHA
101 El Camino Plaza, Suite 105
Sacramento, CA 95815
(916) 566-7471

U.S. Department of Labor - OSHA
1391 Speer Boulevard, Suite 210
Denver, CO 80204-2552
(303) 844-5285

U.S. Department of Labor - OSHA
7935 East Prentice Avenue, Suite 209
Englewood, CO 80111-2714
(303) 843-4500

U.S. Department of Labor - OSHA
One Lafayette Square, Suite 202
Bridgeport, CT 06604
(203) 579-5581

U.S. Department of Labor - OSHA
Federal Building
450 Main Street, Room 613
Hartford, CT 06103
(860) 240-3152

U.S. Department of Labor - OSHA
Caleb Boggs Federal Building
844 N King Street, Room 2209
Wilmington, DE 19801-3319
(302) 573-6518

U.S. Department of Labor - OSHA
8040 Peters Road, Building H-100
Fort Lauderdale, FL 33324
(954) 424-0242

U.S. Department of Labor - OSHA
Ribault Building, Suite 227
1851 Executive Center Drive
Jacksonville, FL 32207
(904) 232-2895

U.S. Department of Labor - OSHA
5807 Breckenridge Parkway, Suite A
Tampa, FL 33610-4249
(813) 626-1177

U.S. Department of Labor - OSHA
450 Mall Boulevard, Suite J
Savannah, GA 31406
(912) 652-4393

U.S. Department of Labor - OSHA
2400 Herodian Way, Suite 250
Smyrna, GA 30080-2968
(770) 984-8700

U.S. Department of Labor - OSHA
LaVista Perimeter Office Park
2183 N. Lake Parkway
Building 7 - Suite 110
Tucker, GA 30084-4154
(770) 493-6644/6742/8419

U.S. Department of Labor - OSHA
210 Walnut Street, Room 815
Des Moines, IA 50309
(515) 284-4794

U.S. Department of Labor - OSHA
1150 North Curtis Road, Suite 201
Boise, ID 83706
(208) 321-2960

U.S. Department of Labor - OSHA
1600 167th Street, Suite 9
Calumet City, IL 60409
(708) 891-3800

U.S. Department of Labor - OSHA
701 Lee Street
Suite #950
Des Plaines, IL 60016
(847) 803-4800

U.S. Department of Labor - OSHA
11 Executive Drive, Suite 11
Fairview Heights, IL 62208
(618) 632-8612

U.S. Department of Labor - OSHA
344 Smoke Tree Business Park
North Aurora, IL 60542
(630) 896-8700

U.S. Department of Labor - OSHA
2918 West Willow Knolls Road
Peoria, IL 61614
(309) 671-7033

U.S. Department of Labor - OSHA
46 East Ohio Street, Room 423
Indianapolis, IN 46204
(317) 226-7290

U.S. Department of Labor - OSHA
217 W. 3rd Street North
Room #4500
Wichita, KS 67202
(316) 269-6644

U.S. Department of Labor - OSHA
John C. Watts Federal Building
330 W. Broadway, Room 108
Frankfort, KY 40601-1922
(502) 227-7024

U.S. Department of Labor - OSHA
9100 Bluebonnet Centre Boulevard
Suite 201
Baton Rouge, LA 70809
(225) 389-0474 (0431)

U.S. Department of Labor - OSHA
639 Granite Street, 4th Floor
Braintree, MA 02184
(617) 565-6924

U.S. Department of Labor - OSHA
Valley Office Park
13 Branch Street
Methuen, MA 01844
(617) 565-8110

U.S. Department of Labor - OSHA
1441 Main Street, Room 550
Springfield, MA 01103-1493
(413) 785-0123

U.S. Department of Labor - OSHA
1099 Winterson Road, Suite 140
Linthicum, MD 21090-2218
(410) 865-2055/2056

U.S. Department of Labor - OSHA
202 Harlow Street, Room 211
Bangor, ME 04401
(207) 941-8177

U.S. Department of Labor - OSHA
100 Middle Street, Suite 410 West
Portland, ME 04101
(207) 780-3178

U.S. Department of Labor - OSHA
40 Western Avenue, Room 608
August, ME 04330
(207) 622-8417

U.S. Department of Labor - OSHA
801 South Waverly Road, Suite 306
Lansing, MI 48917-4200
(517) 327-0904

U.S. Department of Labor - OSHA
300 South 4th Street, Room 1205
Minneapolis, MN 55415
(612) 664- 5460

U.S. Department of Labor - OSHA
6200 Connecticut Avenue, Suite 100
Kansas City, MO 64120
(816) 483-9531

U.S. Department of Labor - OSHA
911 Washington Avenue, Room 420
St. Louis, MO 63101
(314) 425-4289

U.S. Department of Labor - OSHA
3780 I-55 North, Suite 210
Jackson, MS 39211-6323
(601) 965-4606

U.S. Department of Labor - OSHA
2900 4th Avenue North, Suite 303
Billings, MT 59101
(406) 247-7494

U.S. Department of Labor - OSHA
Century Station Federal Office Building
300 Fayetteville Street Mall, Room 438
Raleigh, NC 27601-9998
(919) 856-4770

U.S. Department of Labor - OSHA
Overland - Wolf Building
6910 Pacific Street, Room 100
Omaha, NE 68106
(402) 221-3182

U.S. Department of Labor - OSHA
1640 East Capitol Avenue
Bismark, ND 58501
(701) 250-4521

U.S. Department of Labor - OSHA
279 Pleasant Street, Suite 201
Concord, NH 03301
(603) 225-1629

U.S. Department of Labor - OSHA
1030 St. Georges Avenue
Plaza 35, Suite 205
Avenel, NJ 07001
(732) 750-3270

U.S. Department of Labor - OSHA
500 Route 17 South, 2nd Floor
Hasbrouck Heights, NJ 07604
(201) 288-1700

U.S. Department of Labor - OSHA
Marlton Executive Park, Building 2
701 Route 73 South, Suite 120
Marlton, NJ 08053
(609) 757-5181

U.S. Department of Labor - OSHA
299 Cherry Hill Road, Suite 304
Parsippany, NJ 07054
(973) 263-1003

U.S. Department of Labor - OSHA
505 Marquette Avenue, NW
Suite 820
Albuquerque, NM 87102
(505) 248-5302

U.S. Department of Labor - OSHA
705 North Plaza, Room 204
Carson City, NV 89701
(775) 885-6963

U.S. Department of Labor - OSHA
401 New Karner Road, Suite 300
Albany, NY 12205-3809
(518) 464-4338

U.S. Department of Labor - OSHA
42-40 Bell Boulevard
Bayside, NY 11361
(718) 279-9060

U.S. Department of Labor - OSHA
5360 Genesee Street
Bowmansville, NY 14026
(716) 684-3891

U.S. Department of Labor - OSHA
6 World Trade Center, Room 881
New York, NY 10048
(212) 466-2482

U.S. Department of Labor - OSHA
3300 Vickery Road
North Syracuse, NY 13212
(315) 451-0808

U.S. Department of Labor - OSHA
660 White Plains Road, 4th Floor
Tarrytown, NY 10591-5107
(914) 524-7510

U.S. Department of Labor - OSHA
1400 Old Country Road, Room 208
Westbury, NY 11590
(516) 334-3344

U.S. Department of Labor - OSHA
36 Triangle Park Drive
Cincinnati, OH 45246
(513) 841-4132

U.S. Department of Labor - OSHA
Federal Office Building
1240 East 9th Street, Room 899
Cleveland, OH 44199
(216) 522-3818

U.S. Department of Labor - OSHA
Federal Office Building
200 North High Street, Room 620
Columbus, OH 43215
(614) 469-5582

U.S. Department of Labor - OSHA
Federal Office Building
234 North Summit Street, Room 734
Toledo, OH 43604
(419) 259-7542

U.S. Department of Labor - OSHA
420 West Main, Suite 300
Oklahoma City, OK 73102
(405) 231-5351/5389

U.S. Department of Labor, OSHA
Federal Office Building
1220 Southwest 3rd Avenue, Room 640
Portland, OR 97204
(503) 326-2251

U.S. Department of Labor - OSHA
850 North 5th Street
Allentown, PA 18102
(610) 776-0592

U.S. Department of Labor - OSHA
3939 West Ridge Road, Suite B12
Erie, PA 16506-1887
(814) 833-5758

U.S. Department of Labor - OSHA
Progress Plaza
49 North Progress Avenue
Harrisburg, PA 17109
(717) 782-3902

U.S. Department of Labor - OSHA
U.S. Custom House, Room 242
Second and Chestnut Streets
Philadelphia, PA 19106-2902
(215) 597-4955

U.S. Department of Labor - OSHA
Federal Office Building
1000 Liberty Avenue, Room 1428
Pittsburgh, PA 15222-4101
(412) 395-4903

60 Appendix C OSHA Office Directory

U.S. Department of Labor - OSHA
20 North Pennsylvania Avenue
Penn Place, Room 2005
Wilkes-Barre, PA 18702-3590
(570) 826-6538

U.S. Department of Labor - OSHA
Triple SSS Plaza Building
1510 F. D. Roosevelt Avenue, Suite 5B
Guaynabo, PR 00968
(787) 277-1560

U.S. Department of Labor - OSHA
Federal Office Building
380 Westminster Mall, Room 543
Providence, RI 02903
(401) 528-4669

U.S. Department of Labor - OSHA
1835 Assembly Street, Room 1468
Columbia, SC 29201-2453
(803) 765-5904

U.S. Department of Labor - OSHA
2002 Richard Jones Road, Suite C-205
Nashville, TN 37215-2809
(615) 781-5423

U.S. Department of Labor - OSHA
903 San Jacinto Boulevard, Suite 319
Austin, TX 78701
(512) 916-5783 (5788)

U.S. Department of Labor - OSHA
Wilson Plaza
606 N. Carancahua, Suite 700
Corpus Christi, TX 78476
(512) 888-3420

U.S. Department of Labor - OSHA
8344 East R.L. Thornton Freeway, Suite 420
Dallas, TX 75228
(214) 320-2400 (2558)

U.S. Department of Labor - OSHA
700 E San Antonio
Room C-408
El Paso, TX 79901
(915) 534-6251

U.S. Department of Labor - OSHA
North Starr II, Suite 302
8713 Airport Freeway
Fort Worth, TX 76180-7610
(817) 428-2470 (485-7647)

U.S. Department of Labor - OSHA
350 N. Sam Houston Parkway, Suite 120
Houston, TX 77060
(281) 591-2438 (2787)

U.S. Department of Labor - OSHA
17625 El Camino Real, Suite 400
Houston, TX 77058
(281) 286-0583/0584 (5922)

U.S. Department of Labor - OSHA
Federal Office Building
1205 Texas Avenue, Room 806
Lubbock, TX 79401
(806) 472-7681 (7685)

U.S. Department of Labor - OSHA
160 E 300 South
Heber-Wells Building
P. O. Box 146650
Salt Lake City, UT 84114-6650
(801) 530-6901

U.S. Department of Labor - OSHA
Federal Office Building
200 Granby Street, Room 835
Norfolk, VA 23510
(757) 441-3820

U.S. Department of Labor - OSHA
505 106th Avenue, N.E., Suite 302
Bellevue, WA 98004
(206) 553-7520

U.S. Department of Labor - OSHA
2618 North Ballard Road
Appleton, WI 54911-8664
(920) 734-4521

U.S. Department of Labor - OSHA
Federal Building U.S. Courthouse
500 Barstow Street, Room B-9
Eau Claire, WI 54701
(715) 832-9019

U.S. Department of Labor - OSHA
4802 E. Broadway
Madison, WI 53716
(608) 264-5388

U.S. Department of Labor - OSHA
Henry S. Reuss Building
310 W. Wisconsin Ave., Suite 1180
Milwaukee, WI 53202
(414) 297-3315

U.S. Department of Labor - OSHA
405 Capitol Street
Suite 407
Charleston, WV 25301
(304) 347-5937

OSHA-Approved Safety and Health Plans

Commissioner

Alaska Department of Labor
1111 W. 8th Street, Room 306
P.O. Box 21149
Juneau, AK 99802-1149
(907) 465-2700

Director

Industrial Commission of Arizona
800 W. Washington
Phoenix, AZ 85007
(602) 542-5795

Director

California Department of Industrial Relations
455 Golden Gate Avenue - 10th floor
San Francisco, CA 94102
(415) 703-5050

Commissioner

Connecticut Department of Labor
200 Folly Brook Boulevard
Wethersfield, CT 06109
(860) 566-5123

Director

Hawaii Department of Labor and
Industrial Relations
830 Punchbowl Street
Honolulu, HI 96831
(808) 586-8844

Commissioner

Indiana Department of Labor
State Office Building
402 West Washington Street - Room W195
Indianapolis, ID 46204
(317) 232-2378

Commissioner

Iowa Division of Labor
1000 E. Grand Avenue
Des Moines, IA 50319
(515) 281-3447

Commissioner

Indiana Department of Labor
State Office Building
402 West Washington Street
Room W195
Indianapolis, IN 46204
(317) 232-3325

Secretary

Kentucky Labor Cabinet
1047 U.S. Highway 127 South, Suite 4
Frankfort, KY 40601
(502) 564-3070

Commissioner

Maryland Division of Labor and Industry
Department of Labor Licensing and Regulation
1100 N. Eutaw Street, Room 613
Baltimore, MD 21201-2206
(410) 767-2215

Director

Michigan Department of Consumer and
Industry Services
P.O. Box 30004 - 4th Floor, Law Bldg
Lansing, MI 48909
(517) 373-7230

Commissioner

Minnesota Department of Labor and Industry
443 Lafayette Road
St. Paul, MN 55155
(651) 296-2342

Commissioner

North Carolina Department of Labor
4 West Edenton Street
Raleigh, NC 27601-1092
(919) 807-2900

Commissioner

New Jersey Department of Labor
John Fitch Plaza - Labor Building
Market and Warren Streets
P.O. Box 110
Trenton, NJ 08625-0110
(609) 292-2975

Secretary

New Mexico Environment Department
1190 St. Francis Drive
P.O. Box 26110
Santa Fe, NM 87502
(505) 827-2850

Commissioner

New York Department of Labor
W. Averell Harriman State Office
Building-12, Room 500
Albany, NY 12240
(518) 457-2741

Administrator

Nevada Division of Industrial Relations
400 West King Street
Carson City, NV 89703
(775) 687-3032

Administrator

Oregon Department of Consumer and
Business Services
Occupational Safety and Health Division
(OR-OSHA)
350 Winter Street, N.E., Room 430
Salem, OR 97310-0220
(503) 378-3272

Secretary

Puerto Rico Department of Labor and Human
Resources
Prudencio Rivera Martinez Building
505 Muñoz Rivera Avenue
Hato Rey, PR 00918
(787) 754-2119

Director

South Carolina Department of Labor,
Licensing and Regulation
Koger Office Park, Kingtree Building
110 Centerview Drive
P.O. Box 11329
Columbia, SC 29210
(803) 896-4300

Commissioner

Tennessee Department of Labor
and Workforce Development
710 James Robertson Parkway
Nashville, TN 37243-0659
(615) 741-2582

Commissioner

Labor Commission of Utah
160 East 300 Street, 3rd floor
P.O. Box 146650
Salt Lake City, UT 84114-6650
(801) 530-6901

Commissioner

Virginia Department of Labor
and Industry
Powers-Taylor Building
13 South 13th Street
Richmond, VA 23219
(804) 786-2377

Commissioner

Virgin Islands Department of Labor
2203 Church Street
Christiansted, St. Croix, VI 00820-4660
(340) 773-1990

Commissioner

Vermont Department of Labor
and Industry
National Life Building—Drawer 20
120 State Street
Montpelier VT 05620-3401
(802) 828-2288

Director

Washington Department of Labor
and Industries
P.O. Box 44001
Olympia, WA 98504-4001
(360) 902-4200
(360) 902-5430

Administrator

Worker's Safety and Compensation
Division (WSC)
Wyoming Department of Employment
Herschler Building, 2nd Floor East
122 West 25th Street
Cheyenne, WY 82002
(307) 777-7786

OSHA Consultation Offices

Safety State Program University of Alabama
432 Martha Parham West
Post Office Box 870388
Tuscaloosa, AL 35487
(205) 348-3033

Consultation Section
ADOL/AKOSH
3301 Eagle Street
Post Office Box 107022
Anchorage, AK 99510
(907) 269-4957

OSHA Consultation
Arkansas Department of Labor
10421 West Markham
Little Rock, AR 72205
(501) 682-4522

Consultation and Training
Division of Occupational Safety and Health
Industrial Commission of Arizona
800 West Washington
Phoenix, AZ 85007-9070
(602) 542-1695

CAL/OSHA Consultation Service
2211 Park Towne Circle, Suite #4
Sacramento, CA 95825
(916) 574-2555

Occupational Safety and Health Section
Colorado State University
115 Environmental Health Building
Fort Collins, CO 80523
(970) 491-6151

Division of Occupational Safety and Health
Connecticut Department of Labor
38 Wolcott Hill Road
Wethersfield, CT 06109
(860) 566-4550

Office of Occupational Safety and Health
D.C. Dept of Employment Services
950 Upshur Street, N.W.
Washington, DC 20011
(202) 541-3727

Occupational Safety and Health
Division of Industrial Affairs
Delaware Department of Labor
4425 Market Street
Wilmington, DE 19802
(302) 761-8219

Director of Environmental Safety and Health
Environmental and Occupational Health
College of Public Health
13201 Bruce B. Downs Boulevard
MDC 56
Tampa, FL 33612
(813) 974-9962

Onsite Consultation Program
Georgia Institute of Technology
O'Keefe Building, Room 22
151 6TH Street N.W.
Atlanta, GA 30332
(404) 894-2643

OSHA Onsite Consultation
Department of Labor, Government of Guam
107 F Street
Tiyam, GU 96931
9-1-(671) 475-1101

Consultation and Training Branch
Dept of Labor and Industrial Relations
830 Punchbowl Street
Honolulu, HI 96813
(808) 586-9100

Iowa Workforce Development Labor Services
Bureau of Consultation and Education
1000 East Grand Avenue
Des Moines, IA 50319
(515) 281-7629

Safety and Health Consultation Program
Boise State University
Department of Health
1910 University Drive
Boise, ID 83725
(208) 426-3283

Illinois Onsite Consultation
Industrial Service Division
Department of Commerce and Community Affairs
State of Illinois Center - Suite 3-400
100 West Randolph Street
Chicago, IL 60601
(312) 814-2337

Division of Labor
Bureau of Safety, Education and Training
Room W195
402 West Washington
Indianapolis, IN 46204-2287
(317) 232-2688

7(c)(1) Consultation Program
Kansas Department of Human Resources
512 South West 6th Street
Topeka, KS 66603-3150
(785) 296-7476

Division of Education and Training
Kentucky Labor Cabinet
1047 U.S. Highway 127, South
Frankfort, KY 40601
(502) 564-6895

7(c)(1) Consultation Program
Louisiana Department of Labor
1001 N. 23rd Street, Rm 230
Post Office Box 94094
Baton Rouge, LA 70804-9094
(225) 342-9601

Division of Occupational Safety and Health
Department of Workforce Development
1001 Watertown Street
West Newton, MA 02165
(617) 727-3982

MOSH Consultation Services
Attention: Ms. Colleen Ridler
312 Marshall Avenue Rm 600
Laurel, MD 20707
(410) 880-4970

Division of Industrial Safety
Maine Bureau of Labor Standards
Workplace Safety and Health Division
State House Station #45
Augusta, ME 04333-0045
(207) 624-6460

Consultation Education and Training Division
Bureau of Safety and Regulation
Michigan Department of Consumer
and Industry Services
7150 Harris Drive Post Office Box 30643
Lansing, MI 48909-8143
(517) 322-1809

Department of Labor and Industry
Consultation Division
443 LaFayette Road
Saint Paul, MN 55155
(651) 297-2393

Onsite Consultation Program
Division of Labor Standards
Department of Labor and Industrial Relations
3315 West Truman Boulevard
Post Office Box 449
Jefferson City, MO 65109
(573) 751-3403

Mississippi State University
Center for Safety and Health
2906 North State Street
Suite 201
Jackson, MS 39216
(601) 987-3981

Department of Labor and Industry
Bureau of Safety
Post Office Box 1728
Helena, MT 59624-1728
(406) 444-6418

Bureau of Consultative Services
NC Department of Labor–OSHA Division
4 West Edenton Street
Raleigh, NC 27601-1092
(919) 807-2905

Division of Environmental Engineering
Room 304
1200 Missouri Avenue
Bismarck, ND 58504
(701) 328-5188

Division of Safety and Labor Standards
Nebraska Department of Labor
State Office Building, Lower Level
301 Centennial Mall, South
Lincoln, NE 68509-5024
(402) 471-4717

New Hampshire
Department of Health and Human Services,
Office of Health Management
6 Hazen Drive
Concord, NH 03301-6527
(603) 271-2024

New Jersey Department of Labor
Division of Public Safety and
Occupational Safety and Health
225 E. State Street - 8th Floor West
P.O. Box 953
Trenton, NJ 08625-0953
(609) 292-3923

New Mexico Environment Dept
Occupational Health and Safety Bureau
525 Camino de los Marquez, Suite 3
Post Office Box 26110
Santa Fe, NM 87502
(505) 827-4230

Division of Safety and Health
State Office Campus
Building 12, Room 130
Albany, NY 12240
(518) 457-2238

Safety Consultation and Training Section
Division of Industrial Relations
Department of Business and Industry
1301 Green Valley Parkway
Henderson, NV 89014
(702) 486-9140

On-Site Consultation Program
Bureau of Occupational Safety and Health
LAWS Division/ Ohio Department of Commerce
50 W. Broad Street, Suite 2900
Columbus, OH 43215
(614) 644-2631

Oklahoma Department of Labor
OSHA Division
4001 North Lincoln Boulevard
Oklahoma City, OK 73105-5212
(405) 528-1500

Oregon OSHA
Department of Consumer and Business Services
350 Winter Street, N.E., Room 430
Salem, OR 97310
(503) 378-3272

Indiana University of Pennsylvania
Room 210 Walsh Hall
302 E. Walk
Indiana, PA 15705-1087
(724) 357-2396

Occupational Safety and Health Office
Department of Labor and Human Resources
21st Floor
505 Muñoz Rivera Avenue
Hato Rey, PR 00918
(787) 754-2171

OSHA Consultation Program
Division of Occupational Health
and Radiation Control
Rhode Island Department of Health
3 Capital Hill
Providence, RI 02908
(401) 222-2438

South Carolina Department of Labor,
Licensing and Regulation
3600 Forest Drive
Post Office Box 11329
Columbia, SC 29204
(803) 734-9614

Engineering Extension
Onsite Technical Division
SD State University, West Hall
Box 510,907 Harvey Dunn Street
Brookings, SD 57007
(605) 688-4101

OSHA Consultative Services Division
Tennessee Department of Labor
3rd Floor
710 James Robertson Parkway
Nashville, TN 37243-0659

Workers' Health and Safety Division
Workers' Compensation Commission
Southfield Building
4000 South I H 35
Austin, TX 78704
(512) 804-4640

State of Utah Labor Commission
Workplace Safety and Health
Consultation Services
160 East 300 South
Salt Lake City, UT 84114-6650
(801) 530-6901

Division of Occupational Safety and Health
Vermont Department of Labor and Industry
National Life Building, Drawer #20
Montpelier, VT 05602-3401
(802) 828-2765

Virginia Department of Labor and Industry
Occupational Safety and Health
Training and Consultation
13 South 13th Street
Richmond, VA 23219
(804) 786-6359

Division of Occupational Safety and Health
Virgin Islands Department of Labor
3021 Golden Rock
Christiansted St. Croix, VI 00840
(809) 772-1315

Washington Dept of Labor and Industries
Division of Industrial Safety and Health
Post Office Box 44643
Olympia, WA 98504
(360) 902-5638

Wisconsin Department of Health and
Human Services
Division of Health
Section of Public Occupational Health
Room 112
1414 East Washington Avenue
Madison, WI 53703
(608) 266-9383

Wisconsin Department of Commerce
Division of Marketing, Advocacy
and Technical Development
Bureau of Manufacturing Assessment
N14W23833 Stone Ridge Drive Suite B100
Waukesha, WI 53188-1125
(262) 523-3044

West Virginia Department of Labor
Capitol Complex Building #3, Room 319
1800 East Washington Street
Charleston, WV 25305
(304) 558-7890

Wyoming Department of Employment
Workers' Safety and Compensation Division
Herschler Building, 2 East
122 West 25th Street
Cheyenne, WY 82002
(307) 777-7786

