

CHAPTER 5: GENERAL SITE AND BUILDING ELEMENTS

501 General

501.1 Scope. General *site* and *building elements* required to be *accessible* by Chapter 2 shall comply with the applicable provisions of this chapter.

502 Parking Spaces

502.1 General. Car and van parking *spaces* required to be *accessible* shall comply with 502.

502.2 Vehicle Spaces. Car and van parking *spaces* shall be 96 inches (2440 mm) wide minimum, shall be marked to define the width, and shall have an adjacent access aisle complying with 502.3.

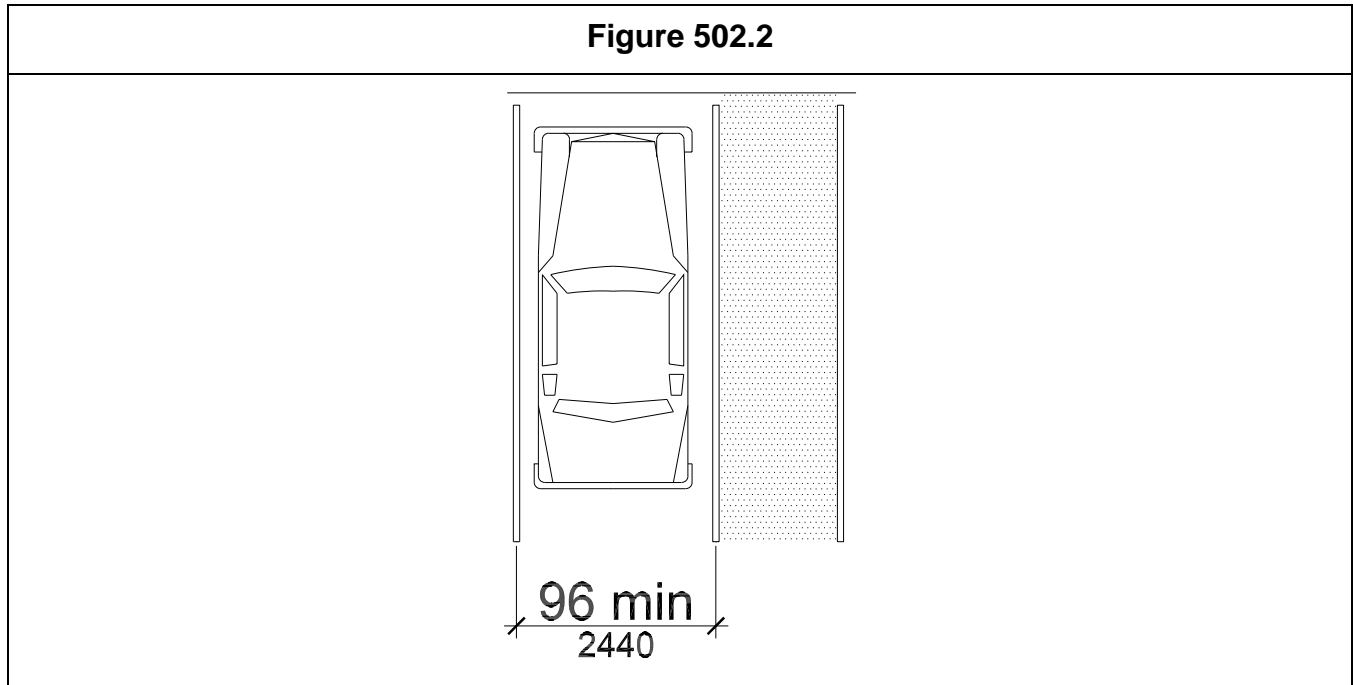

502.3 Access Aisle. Access aisles serving parking spaces shall comply with 502.3. Access aisles shall adjoin an *accessible route*. Two parking spaces shall be permitted to share a common access aisle.

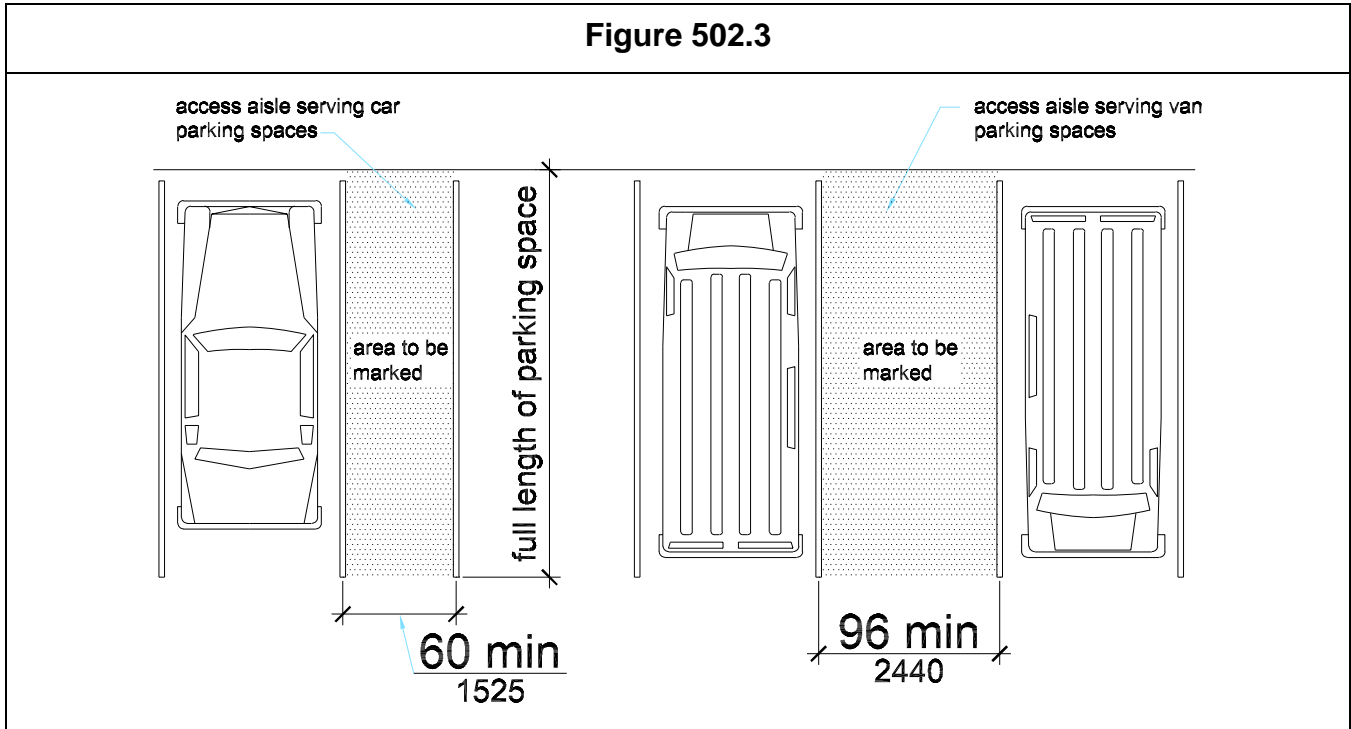

502.3.1 Width. Access aisles serving car parking spaces shall be 60 inches (1525 mm) wide minimum. Access aisles serving van parking spaces shall be 96 inches (2440 mm) wide minimum.

502.3.2 Length. Access aisles shall extend the full length of the parking spaces they serve.

502.3.3 Marking. Access aisles shall be marked so as to discourage parking in them.

Advisory 502.3.3

The method and color of marking are not specified in this document but may be addressed by State or local laws or regulations. Since van access aisles are required to be as wide as the *accessible parking space*, it is important that they be clearly marked. Bollards or other barriers can help prevent misuse of the aisle provided that they do not obstruct the access aisle or required connecting *accessible route*. If used, bollards must be placed at the boundary of the access aisle so they do not prevent the deployment of *wheelchair* lifts or the use of mobility aids.

502.4 Floor or Ground Surfaces. Parking *spaces* and access aisles serving them shall comply with 302. Changes in level are not permitted. Access aisles shall be at the same level as the parking *spaces* they serve.

Advisory 502.4

Access aisles are required to be level in all directions to provide a level surface for *wheelchair* transfer to and from vehicles.

EXCEPTION: Slopes not steeper than 1:48 shall be permitted.

502.5 Vertical Clearance. Van parking *spaces*, access aisles serving them, and a vehicular route from an *entrance* to van parking *spaces* and from van parking *spaces* to an exit shall provide a vertical clearance of 98 inches (2490 mm) minimum.

502.6 Identification. Where *accessible* parking *spaces* are required to be identified by *signs*, the *signs* shall include the International Symbol of Accessibility complying with 703.7. Such *signs* shall be 60 inches (1525 mm) minimum above the floor or ground surface measured to the bottom of the *sign*.

503 Passenger Loading Zones

503.1 General. Passenger loading zones required to be *accessible* shall comply with 503.

503.2 Vehicle Pull-up Space. Passenger loading zones shall provide a vehicular pull-up *space* 96 inches (2440 mm) minimum in width, 20 feet (6100 mm) minimum in length and an adjacent access aisle complying with 503.3.

503.3 Access Aisle. Access aisles serving passenger loading zones shall comply with 503.3. Access aisles shall adjoin an *accessible route*.

Figure 503.3

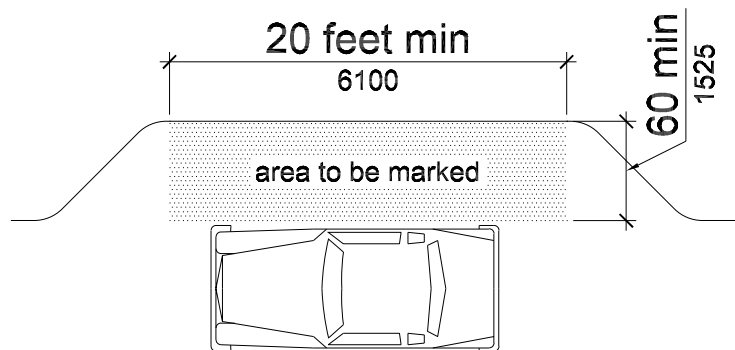

503.3.1 Width. Access aisles serving vehicle pull-up *spaces* shall be 60 inches (1525 mm) wide minimum.

503.3.2 Length. Access aisles shall be 20 feet (6100 mm) minimum in length and shall extend the full length of the vehicle pull-up *spaces* they serve.

503.3.3 Marking. Access aisles shall be marked so as to discourage parking in them.

503.4 Floor and Ground Surfaces. Vehicle pull-up *spaces* and access aisles serving them shall comply with 302. Changes in level are not permitted. Access aisles shall be at the same level as the vehicle pull-up *space* they serve.

EXCEPTION: Slopes not steeper than 1:48 shall be permitted.

503.5 Vertical Clearance. Vehicle pull-up *spaces*, access aisles serving them, and a vehicular route from an *entrance* to the passenger loading zone, and from the passenger loading zone to an exit, shall provide a vertical clearance of 114 inches (2895 mm) minimum.

504 Stairways

504.1 General. Stairs required to be *accessible* shall comply with 504.

Advisory 504.1

Although these requirements do not mandate handrails on stairs that are not part of a means of egress, State or local *building* codes may require handrails.

504.2 Treads and Risers. All steps on a flight of stairs shall have uniform riser heights and uniform tread depths. Risers shall be 4 inches (100 mm) minimum in height and 7 inches (180 mm) maximum in height. Treads shall be 11 inches (280 mm) minimum in depth, measured from riser to riser.

Figure 504.2

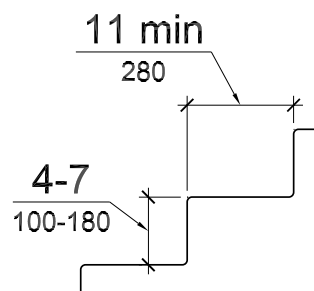

504.3 Open Risers. Open risers are not permitted.

504.4 Tread Surface. Stair treads shall comply with 302. Changes in level are not permitted.

EXCEPTION: Treads shall be permitted to have a slope not steeper than 1:48.

504.5 Nosings. The radius of curvature at the leading edge of the tread shall be 1/2 inch (13 mm) maximum. Nosings that project beyond vertical risers shall have the underside of the leading edge curved or beveled. If not vertical, risers shall slope under the tread at an angle of 30 degrees maximum from vertical; however, the permitted projection of the nosing shall be 1-1/2 inches (38 mm) maximum beyond the rear of the tread below.

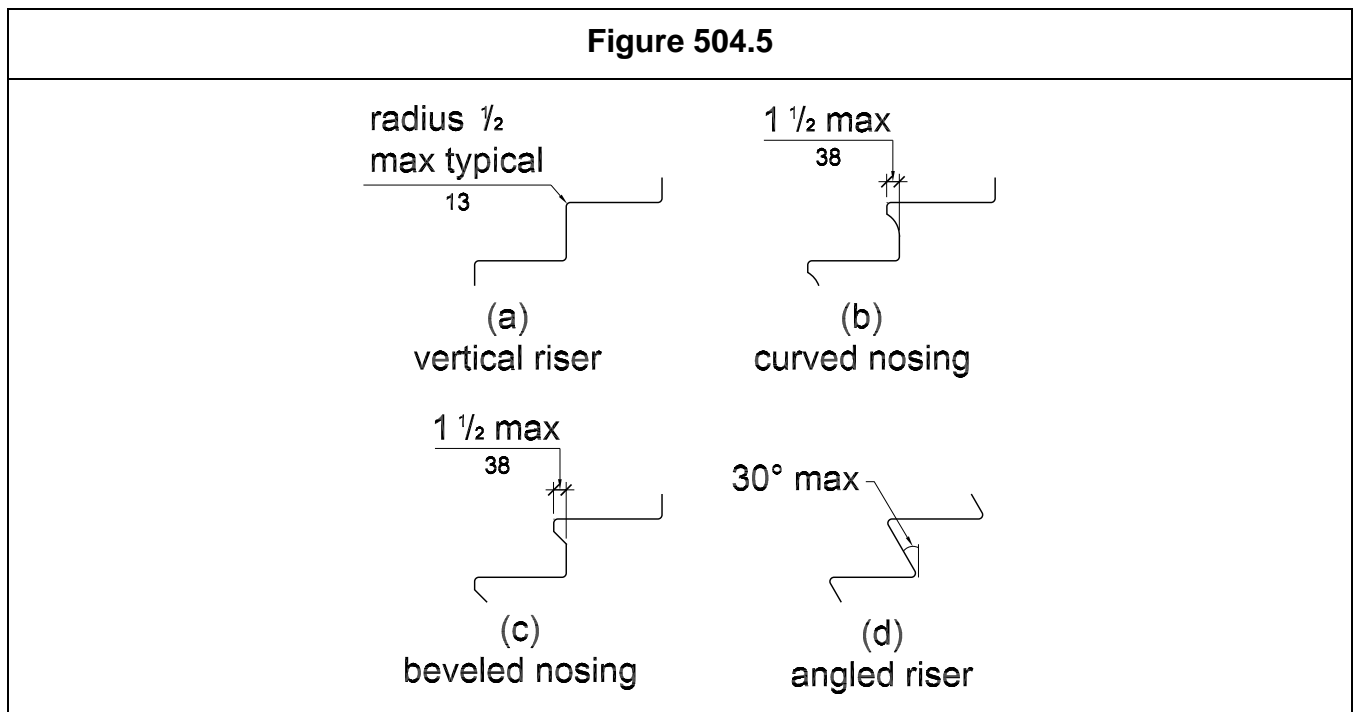

504.6 Handrails. Stairs shall have handrails complying with 505.

504.7 Wet Conditions. Landings subject to wet conditions shall be designed to prevent the accumulation of water.

505 Handrails

505.1 General. Handrails required by 405 at *ramps* or 504 at stairs shall comply with 505.

505.2 Where Required. Handrails shall be provided on both sides of stairs and *ramps*.

EXCEPTIONS: 1. Handrails are not required on both sides of aisle stairs and aisle *ramps* provided with a handrail at either side or within the aisle width.

2. Handrails are not required on *ramps* with a rise of 6 inches (150 mm) maximum.

505.3 Continuity. Handrails shall be continuous within the full length of each stair flight or *ramp* run.

EXCEPTION: Handrails are not required to be continuous in aisles serving seating.

505.4 Height. Top of gripping surfaces of handrails shall be 34 inches (865 mm) minimum and 38 inches (965 mm) maximum vertically above stair nosings and *ramp* surfaces. Handrails shall be at a consistent height above stair nosings and *ramp* surfaces.

Figure 505.4

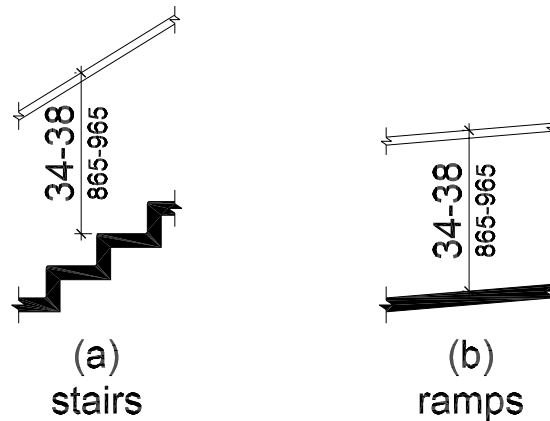

Advisory 505.4

The requirements for stair and *ramp* handrails in this document are for adults. When children are the principle users in a *building or facility* (e.g., elementary schools), a second set of handrails at an appropriate height can assist them and aid in preventing accidents. A maximum height of 28 inches (710 mm) measured to the top of the gripping surface from the ramp surface or stair nosing is recommended for handrails designed for children. Sufficient vertical clearance between upper and lower handrails, 9 inches (230 mm) minimum, should be provided to help prevent entrapment.

505.5 Clearance. Clearance between handrail and wall shall be 1-1/2 inches (38 mm) minimum.

Figure 505.5

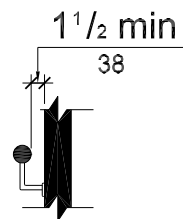

505.6 Gripping Surface. Gripping surfaces shall be continuous, without interruption by newel posts, other construction *elements*, or obstructions.

EXCEPTION: Handrail brackets or balusters attached to the bottom surface of the handrail shall not be considered obstructions provided they comply with the following:

- a. not more than 20 percent of the handrail length is obstructed;
- b. horizontal projections beyond the sides of the handrail occur 2-1/2 inches (64 mm) minimum below the bottom of the handrail; and

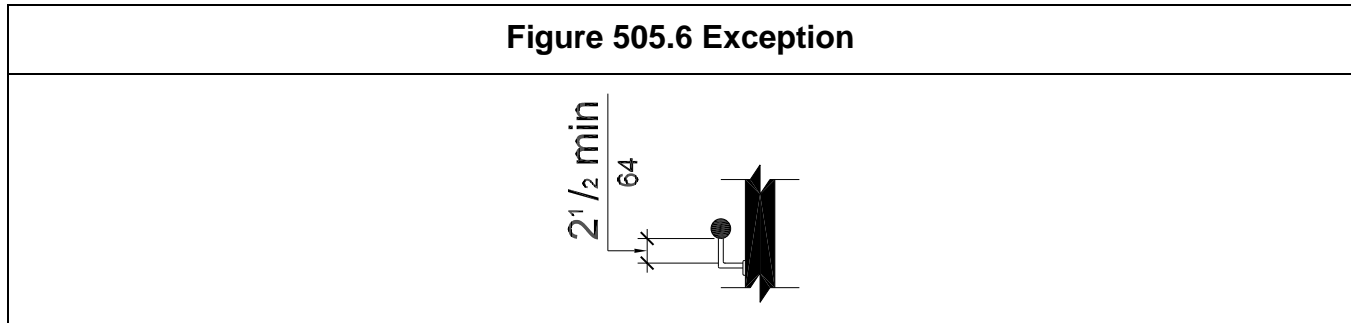

c. edges have a 1/8 inch (3.2 mm) minimum radius.

505.7 Cross Section. Handrails shall have a circular cross section with an outside diameter of 1-1/4 inches (32 mm) minimum and 2 inches (51 mm) maximum, or shall provide equivalent graspability in accordance with 505.7.1.

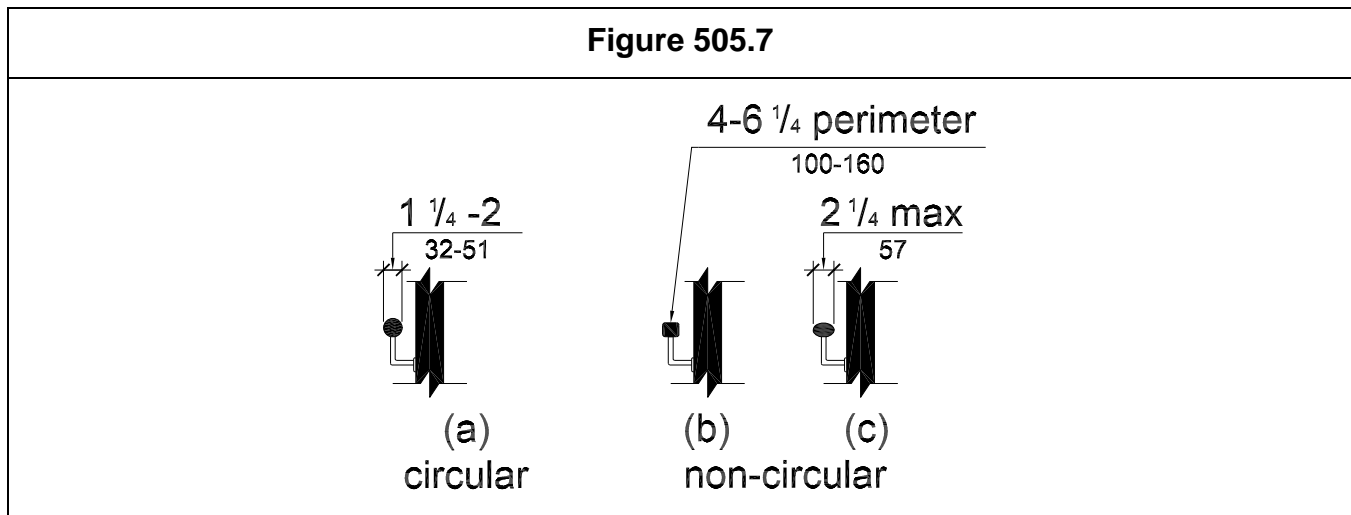

505.7.1 Non-Circular Cross Sections. Non-circular cross sections shall have a perimeter dimension of 4 inches (100 mm) minimum and 6-1/4 inches (160 mm) maximum, and a cross-section dimension of 2-1/4 inches (57 mm) maximum.

505.8 Surfaces. Handrails and any wall or other surfaces adjacent to them shall be free of any sharp or abrasive *elements*. Edges shall have a 1/8 inch (3.2 mm) minimum radius.

505.9 Fittings. Handrails shall not rotate within their fittings.

505.10 Handrail Extensions. Handrails shall extend beyond stair runs and *ramp* runs in accordance with 505.10.

EXCEPTIONS: 1. Extensions are not required for continuous handrails at the inside turn of switchback or dogleg stairs and *ramps*.

2. Extensions are not required for handrails in aisles serving seating where the handrails are necessarily discontinuous to provide access to seating and to permit crossovers within the aisle.

3. In *alterations*, full extensions of handrails shall not be required where such extensions would be hazardous or impossible due to plan configuration.

505.10.1 Top and Bottom Extension at Ramps. *Ramp* handrails shall extend horizontally above the landing for 12 inches (305 mm) minimum beyond the top and bottom of *ramp* runs. Such extension shall return to a wall, guard, or the walking surface, or shall be continuous to the handrail of an adjacent *ramp* run.

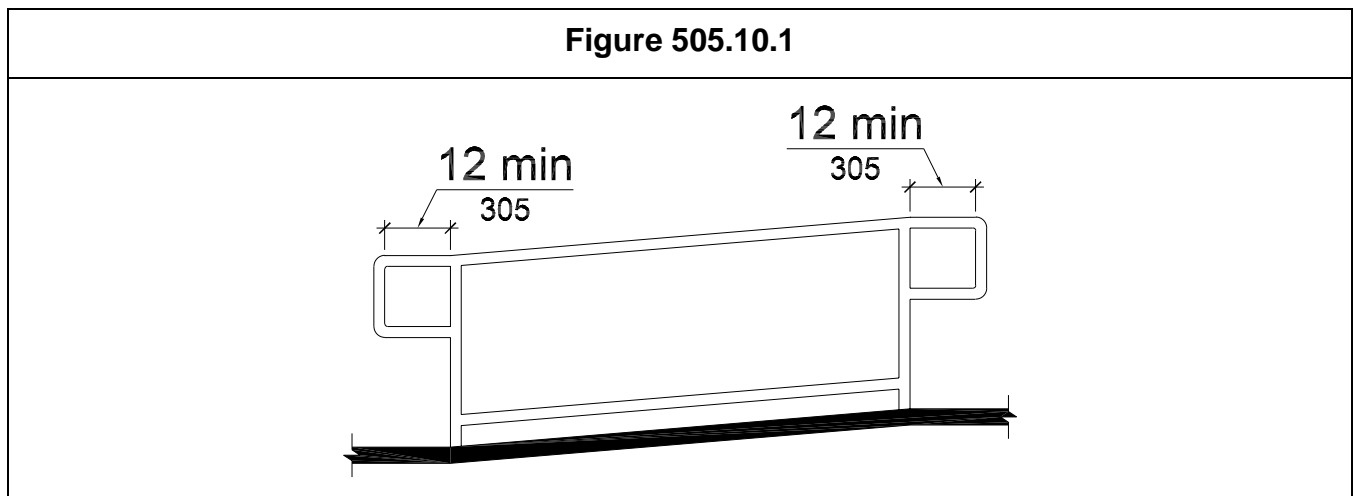

505.10.2 Top Extension at Stairs. At the top of a stair flight, handrails shall extend horizontally above the landing for 12 inches (305 mm) minimum beginning directly above the first riser nosing.

Such extension shall return to a wall, guard, or the walking surface, or shall be continuous to the handrail of an adjacent stair flight.

Figure 505.10.2

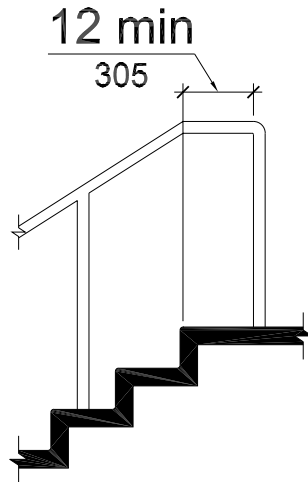

505.10.3 Bottom Extension at Stairs. At the bottom of a stair flight, handrails shall extend at the slope of the stair flight for a horizontal distance equal to one tread depth beyond the last riser nosing and an additional 12 inches (305 mm) minimum horizontally at a height equal to that of the sloping portion of the handrail as measured above the stair nosings. Such extension shall return to a wall, guard, or the walking surface, or shall be continuous to the handrail of an adjacent stair flight.

Figure 505.10.3

