

# **APEC AIR SHIPMENT OF LIVE AND FRESH FISH & SEAFOOD GUIDELINES**

---

---

**A Manual on  
Preparing, Packaging and Packing  
Live and Fresh Fish & Seafood Air Shipments  
along with Customs and Inspection Guidelines  
for Six APEC Member Economies**

**First Edition**



**ASIA-PACIFIC ECONOMIC COOPERATION**

**APEC Fisheries Working Group  
January 1999**

---

---

Published by First Coastal Corporation

for the APEC Secretariat  
438 Alexandra Road  
#14-01/04 Alexandra Point  
Singapore 119958  
Tel: (65) 276 1880  
Fax: (65) 276 1775  
Email: [info@mail.apecsec.org.sg](mailto:info@mail.apecsec.org.sg)  
Web site: <http://www.apecsec.org.sg>

**81999 APEC Secretariat**

APEC #98-FS-03.1

ISBN # 0-9669316-0-2

**APEC  
AIR SHIPMENT  
OF LIVE AND FRESH FISH & SEAFOOD  
GUIDELINES**

---

Developed by:

First Coastal Corporation  
4 Arthur Street  
Westhampton Beach, New York 11977 USA  
Telephone: (1) 516-288-2271  
Fax: (1) 516-288-8949  
E-mail: [mail@firstcoastal.net](mailto:mail@firstcoastal.net)

Aram V. Terchunian, President  
Nancy A. Kunz, Project Coordinator  
Linda J. O'Dierno, Project Coordinator

January 1999

#### NOTE BENE:

It should be carefully noted that import regulations tend to be extremely volatile. Regulations are often adopted without notification and some regulations which have been on the books for years and never invoked are suddenly enforced. Often these shifts are in response to specific trade and sanitation issues. It is best to check with the buyer to make sure that the product will clear Customs and that all of the required documentation has been included.

#### ACKNOWLEDGMENTS:

The Project Team is grateful for the assistance received from the many organizations and individuals interviewed during the course of this investigation and during the development and preparation of this manual. The team apologizes if any person or organization has been omitted from the acknowledgements: Kwun Tung Wholesale Fish Market, Aberdeen Wholesale Fish Market, Hong Kong Fish Marketing Organization, CHOW CHAN HONG, WONG pui-Kwong, LEUNG Sze-fai, LEE Chung-piu, Johnny Y.K. CHU, NG Wai-ming, Fanny CHAU, Ira E. Kasoff, Hong Kong Department of Health, Cathay Pacific Cargo, Chung MAK, Ray Lo Tak Wai, Charles K.L. Tse, Maria NG, United Airlines Worldwide, Sam S.C. Cheung, Jacky Yu, Andy M.T. Yuen, Northwest Airlines, Dorothy Yeung, Master Champion Holding Ltd., Kathy Kingston, Daily Fresh & Company, Frinda Lee, Union Fine Foods Co. (HK) Ltd., Roy T.Tan, Tri Valley Growers, Phillip C. Holloway, Japan Ministry of Health and Welfare, Hajime Toyofuku, Embassy of the United States of America-Tokyo, Gregory Loose, Tomohiro Asakawa, International Express, Yoshiaki Nozaki, Kenji Nakato, Mitsuo Mizutani, Toho Suisan Co, Ltd, Shin'ichi Gorai, Sanwa Kaisan Co Ltd., Akira Umeda, Joseph Theodore Kay, Embassy of the United States of America-Seoul, Christina F. Halle, Noryang Jin Fisheries Marketing Co, Ltd, Young-Ho Lee, Kabi Global, Woo Joo Chang, Korean American Business Institute, Hae-Sang Yoo, Daerim Corporation, Michelle Kim, Yang-Gee Paik, Korean Air, D.I. Yoo, J.K. Chung, Manna Seafoods Co, Ltd, Y.T. Ahn, Chinese Taipei Bureau of Commodity Inspection & Quarantine, Hans Yang, Sue-Jen Huang, Yih-Sin Su, American Institute in Taiwan, Daniel A. Marinez, Elite Foods International Corp., Kay S.L. Huang, James Hay, Wellcome Taiwan Company, Ltd, Rabin Wang, Primary Production Department Singapore, Cheok Weng Chong, Seawaves Frozen Food PTE, Ltd, William Tang, Seafood Industries Association Singapore, Loy Ngiap Whay, Johnny Peh, Mary Low, United States Department of Commerce, John Tennyson, Steve Winters and Lund's Fisheries, Mike Byrne.

# TABLE OF CONTENTS

<b>INTRODUCTION</b> .....	1
---------------------------	---

## **SECTION ONE: PREPARING THE SHIPMENT FOR THE GLOBAL MARKET**

<b>1. GENERAL PREPARATION</b> .....	3
Bacterial Growth and Temperature .....	4
Packaging Systems .....	4
Handling Product .....	5
General Shipping Rules .....	5
International Freight Forwarders .....	6
<b>2. DOCUMENTATION</b> .....	6
Air Waybill .....	7
Certificate of Origin .....	8
Commercial Invoice .....	8
Health (Sanitary) Inspection Certificate .....	8
Shipper's Export Declaration .....	9
ATA Carnets .....	9
Harmonized Commodity Code .....	9
Shipper's Certificate for Live Animals .....	10
Insurance Certificate .....	11
CITES Certificate .....	11
<b>3. PACKAGING FOR THE GLOBAL MARKET</b> .....	12
Insulation .....	14
Expanded Polystyrene .....	15
New Insulating Materials .....	15
Coolants .....	15
Modified Atmosphere Packaging .....	16
<b>4. PACKING FOR THE GLOBAL MARKET</b> .....	16
General Information .....	16
Shipping Live Fish and Seafood .....	17
E Type Containers .....	19
Unit Load Devices .....	19
Marking and Labeling .....	20
Special Marking Requirements for Dry Ice .....	21
Product Identification Markings .....	21
<b>5. AIRLINES AND AIR CARGO CARRIERS</b> .....	21
General Information .....	22
Claims .....	24

Temperature Recording Devices .....	24
Insurance .....	24

## **SECTION TWO: PRODUCT SPECIFIC INFORMATION**

1. Fresh Finfish .....	27
Fresh Tuna .....	27
Fresh Flatfish .....	28
2. Live Finfish .....	29
Specialized Transport Systems .....	29
Breathing Bags .....	30
Standard Shipping Procedures .....	30
Shipment Markings/Labeling for Live Finfish .....	32
Special Packaging for Live Finfish .....	33
3. Live Eels .....	34
4. Live Shrimp .....	34
5. Live Lobsters .....	35
6. Live Abalone .....	36
7. Live Green Sea Urchins .....	37
8. Live Oysters .....	37
9. Live Mussels .....	38
10. Live Crabs .....	38

## **SECTION THREE: MARKET SPECIFIC INFORMATION**

Chinese Taipei .....	39
Hong Kong .....	51
Seoul .....	65
Singapore .....	77
Tokyo .....	97
United States of America. ....	119

## **SECTION FOUR: INSPECTION SYSTEMS**

HACCP .....	151
ISO 9000 .....	152

**APPENDICES:**

**AIR CARGO CONTACTS**

Chinese Taipei .....i  
Hong Kong .....ii  
Seoul, Korea .....iii  
Singapore .....iv  
Tokyo. ....v  
USA, Los Angeles .....vi  
USA, New York. ....vii

**MEASUREMENT CONVERSION CHART** .....ix

**SELECTED INTERNET SITES** .....xiii

**CITES (RELEVANT SPECIES)** .....xv

**EXPORT GLOSSARY** .....xxi

## INTRODUCTION

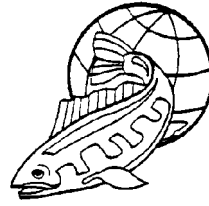

Exporting and importing can be a practical, profitable and challenging endeavor for fish and seafood firms. Currently, the worldwide demand for fresh and live fish and seafood products is growing. Companies within Pacific Rim economies have the product and a golden opportunity to enter and expand into global fresh and live fish and seafood markets.

Accessing these lucrative markets often requires air cargo transportation of fragile fish and seafood products over great distances. Live and fresh fish and seafood are extremely dependent on the transit environment to maintain their optimum selling condition and avoid mortality. Special packing systems should be employed to avoid temperature abuse and counteract rough handling. Those special transportation systems coupled with changing government regulations can make it difficult for companies to achieve their full selling potential in the live and fresh fish and seafood export market.

There are constant changes and improvements in the technology of air cargo transportation of live and fresh fish and seafood. The fish and seafood, air cargo and packaging industries are always looking for ways to make packaging systems safer, more cost effective and easier to use. New and innovative systems are developed on a regular basis to meet the requirements for individual species and target markets. Finding the best system can be a hit or miss but establishing working relationships with air cargo carriers and freight forwarders can serve to keep shippers informed of packaging up-dates and improvements.

Consulting with air cargo carriers and freight forwarders will also result in a better understanding of Customs procedures in the APEC Economies. Rules and regulations regarding import and export change routinely. Although, the manual provides relevant information on regulations that were current at the time of publication, differing regulations may be operative at the time that shipments are made. Avoiding problems prior to shipment is a more desirable result than having a shipment detained by Customs. Delays in Customs often results in decreased product quality and a corollary decrease in product value.

Direct involvement in global markets can return a greater profit than selling through an agent or a broker. But it requires an increased investment of time and effort and a commitment to detail and follow through. Attention to communication becomes more important. Different Economies pose the challenges of great travel distances, time zone differences, languages, business customs and approved species common names. Differing Economies' business practices, tariff structures,



government regulations, currency exchanges and internal and external transportation systems must also be considered.

Experience in international markets has shown that varying Economies' import regulations can be extremely volatile. Regulations are often adopted or enforced without notification. Regulations "on the books" for years and never invoked can suddenly be enforced. These shifts in policy are frequently in response to specific trade issues. It is usually best to work with an experienced importer/buyer or freight forwarder to help ensure that live and fresh fish and seafood products clear Customs with the appropriate documentation in place.

There is a calculated amount of information overlap within this manual. This is intentional on the part of the authors. It ensures that reading selected sections will provide comprehensive and/or essential information on the preparation and shipping of live and fish and seafood.

This manual should assist in preparing the supplier/shipper to meet the expectations of APEC Economies' Customs regulations and help smooth the way in shipping live and fresh fish and seafood products.

**SECTION ONE:  
PREPARING THE SHIPMENT  
FOR THE GLOBAL MARKET**

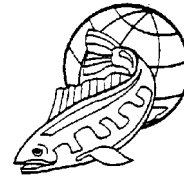

## **11. GENERAL PREPARATION**

When preparing to airship live and fresh food fish and shellfish, including cultured fish and fish fry (to be known as “fish and seafood” for the remainder of the manual), the shipper must be aware of packing, labeling, documentation and insurance requirements for both the country of origin, the country/region of destination and the air cargo carrier. Because these regulations change often, the best source of up-to-date information is a reliable importer/buyer or freight forwarder and an air cargo carrier that handles fish and seafood on a regular basis. These shipping requirements, often time consuming and expensive, are magnified when the product is either fresh or live.

Since price is often dependent upon product quality, it is critical to ensure that product arrives in the best possible condition at its final destination. When dealing with fresh or live product, Customs and handling delays reduce product quality and can decrease profits for all concerned. When the product is being shipped to distant customers and must pass through a number of different handlers, the exporter must be diligent in following all shipping requirements to help ensure that the **product:**

- ✈ *Is handled correctly at the plant/farm to assure excellent preshipping condition.*
- ✈ *Is packed correctly so that it arrives in good condition.*
- ✈ *Is labeled correctly to ensure that it is handled properly, arrives on time and at the correct final destination.*
- ✈ *Is documented correctly to meet foreign government regulations as well as meet proper collection standard.*
- ✈ *Is insured against damage, loss or pilferage (This can be the responsibility of the buyer or the seller depending upon the terms of the contract.).*

- ✈ *Arrives at the final destination at a time during which it can be quickly processed and released by Customs and inspection services.*
- ✈ *Travels by the most direct and fastest routing possible.*

Selecting high quality product for air shipment adds extra assurance that the product will arrive in a condition acceptable to the buyer. Air shipment costs are high. In order to offset those costs against profit margins the best possible price must be obtained for the product. This will only be achieved if the product arrives at its destination in prime condition.

### ■ **Bacterial Growth and Temperature**

Bacterial contamination of shipping containers and other materials that come in contact with product can lead to product deterioration and, in the case of live fish and seafood, mortality. Through proper sanitation procedures and low temperatures within the container, bacterial growth can be controlled and slowed.

Critical factors affecting temperature during air shipment include:

- P The initial temperature of the product.
- P The mass of the product.
- P The packaging system used.

### ■ **Packaging Systems**

The packaging system refers to the type of coolant, insulation, water proof materials and outer carton used. Any reused packaging materials should be thoroughly sanitized to limit bacterial growth. Fresh products should be chilled prior to packing. Chilling also slows bacterial growth.

Because of potential corrosion problems, airlines have very specific requirements about packaging systems used for fish and seafood products. Saltwater and brine are even more corrosive than freshwater.

Airlines, generally, recommend using polyethylene bags to pack fish and seafood. Polyethylene is superior to vinyl chloride in terms of cost savings, water tightness and strength. The major disadvantage is that it can be easily punctured by sharp objects. In all cases, bag thickness should be sufficient to retain liquids and resist punctures. Generally, shippers double-bag product.

A water absorbent material is recommended for inclusion in the packaging system to avoid leakage. This can be an absorbent pad that is impregnated with an organic gel agent, a simple absorbent pad, newspapers, wood shavings or shredded paper. Gel agents effectively trap water. By removing drip water from the product, bacterial growth can be slowed.

## ■ Handling Product

### **FRESH FISH AND SEAFOOD QUALITY IS DEPENDENT UPON:**

- Condition of the fish and seafood at time of harvest.
- Method of harvest and handling.
- Species of fish and seafood.
- Post mortem changes in the fish and seafood.

Product handling that assures high quality should begin on the fishing vessel or at the fish farm. Quality levels will also depend on natural factors including seasonal changes, particular harvest areas, feeding behavior, sex and spawning condition of the fish and seafood.

Harvest methods and onboard handling factor greatly in maintaining product quality and freshness. For example, the rough gloves used by harvesters can cause physical damage leading to bacterial infections with a significant reduction in harvest value. Holding tanks for live fish and seafood should be designed to avoid physical damage. Only fish and seafood in prime condition should be selected for live export.

Some importers have specific requirements regarding product handling, pack styles and size grading. Check with the importer/buyer, prior to packing, to determine the particular requirements. This attention to detail may ensure the best possible price.

## ■ General Shipping Rules

Although the actual shipping of live and fresh fish and seafood products may prove difficult, time consuming and complicated, following two general rules should make the process easier:

1. Organize and plan the most cost-effective air freight policy before getting ready to ship.
2. Obtain assistance from professional shippers/agents and others whenever possible.

When working with fresh or live products, diligent handling prior to shipment plays an important role in guaranteeing the arrival of the product in good condition.

Fresh products should be prechilled to 0° Centigrade prior to packing. Icing, brine chilling and other methods can be used. Prechilling the container and other packaging material can also maintain a low temperature during shipment. Prechilling the container prevents products from absorbing package heat. Packaging procedures should be conducted in a quick and efficient manner to minimize temperature increases. Products should be kept under refrigeration until they are delivered to the air cargo carrier.

Always check with the shipper and buyer to confirm that the selected packaging type is acceptable.

### ■ **International Freight Forwarders**

Freight forwarders are independent businesses that handle export shipments for compensation. The selection of a reputable freight forwarder familiar with overseas air shipment of live/fresh fish and seafood can make a substantial difference in product quality. International freight forwarders should be familiar with import rules and regulations in foreign countries, methods of shipping, export regulations and the necessary documentation. A knowledgeable freight forwarder can assist in air line packaging requirements and in providing Customs information. Some freight forwarders specialize in fish and seafood products.

In addition, freight forwarders can review the letter of credit, commercial invoice, packing list, and other documents to ensure that everything is in order. They may also make arrangements with Customs brokers to ensure that the goods comply with all necessary documentation. The cost of these services is a legitimate export expense and should be factored into the final price charged to the customer. Some airlines will not work directly with exporters and prefer to work with a freight forwarder.

## **12. DOCUMENTATION**

Fish and seafood exports move on paper. Major and costly delays in moving products are caused by missing or inadequate documentation. Check with the buyer to make sure that the most current air cargo packaging and Customs requirements are understood. The seller has the responsibility to ensure that the buyer or the agent has the correct flight details before the product is in the air. Copies of all documents should be faxed to the buyer or agent before the product lands at the final destination.

Some Customs authorities will accept faxed copies of the required documentation. Faxing the documentation will not only provide the buyer with the information needed to accept the shipment and clear Customs, but may also avoid the considerable delays caused by missing documentation.

To facilitate import clearance, a set of required documents should be securely attached to one package of the consignment. This is in addition to the set of documents that must be attached to the air waybill.

### ■ **Air Waybill**

An air waybill is a receipt for the cargo and a contract for transportation between a shipper and an air cargo carrier. The air waybill provides documentary evidence that a shipment has been made and is, therefore, a receipt. It also indicates the condition of the product upon the carrier's acceptance. The air waybill will show the number of packages being shipped, the weight of the shipment and the type of product being shipped. It should also include a 24-hour telephone number for the shipper.

The "Handling Information" box of the air waybill should include information about the contents of the shipment such as: "*LIVE*" or "*FRESH*", "*In case of delay, refrigerate if possible*", "*Hold in cooler for pick-up.*"

If dry ice is used, the following phrase must be indicated on the handling information section of the air waybill: "*Dangerous Goods--Shipper's Declaration Not Required*". The entry for the "Nature and Quantity of Goods" should describe the product, include the dimensions or volume and, **if dry ice is used**, provide the following dangerous goods information:

- Proper shipping name which is either "CARBON DIOXIDE, solid (dry ice)" or "DRY ICE".
- Hazard class number for Dry Ice which is "9".
- UN identification number for dry ice which is UN 1845.
- Number of packages containing dry ice.
- Net quantity of dry ice per package (dry ice amount **MUST** be in kilograms).
- UN Packing Group for Dry Ice which is "III".

For example: A shipment of four packages of fresh salmon, each containing two kilograms of dry ice, the entry would read:

**"FRESH SALMON, DRY ICE; 9; UN 1845; 4 X 2 kg III"**

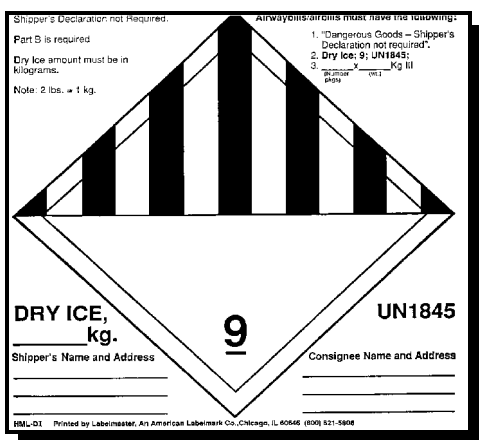

The dry ice label should also be affixed to all packages containing dry ice.

### ■ Certificate of Origin

The Certificate of Origin is a document required by some countries which is used to assure the buying country precisely in which country the goods were produced. The Certificate of Origin is issued by the competent authority in the exporting country.

### ■ Commercial Invoice

A commercial invoice is a bill for the goods from the seller to the buyer. It is often used by governments to determine the true value of goods for the assessment of Customs duties. It is also used in the preparation of consular documentation and to develop import/export statistics.

Governments using the commercial invoice to control imports often specify its form, content, number of copies, language to be used, etcetera. A commercial invoice should include basic information about the transaction including a description of the goods, the address of the shipper and seller, delivery and payment terms, etcetera. The description of the product is important. It must correspond with the other forms. The buyer needs the commercial invoice to prove ownership and to arrange payment.

### ■ **Health (Sanitary) Inspection Certificate**

Some importers and countries require a health inspection certificate. The need for a health certificate may also vary depending on the product. These certificates are issued by the competent authority or its designee in the country of origin. Essentially this certifies that the product meets certain standards imposed by the importing country (such as, permissible level of mercury, bacterial count, level of chemical contaminants, etcetera).

Foreign import requirements for fish and seafood products tend to change frequently. Check with the buyer or local consulate to determine what type (s) of inspection and certification is needed.

### ■ **Shippers Export Declaration**

Some countries require a shipper's export declaration to control exports and as a source document for export statistics. It includes complete information on the shipment. This document is used to indicate proper authorization to export. It generally contains specific information about the shipment including: 1) description of the products, 2) net and gross weights, 3) value, 4) shipper's name, and; 5) consignee's name, etc. A Harmonized Commodity Code number is usually required.

### ■ **ATA Carnets**

The ATA Carnet system permits commercial and professional travelers to take commercial samples, advertising and promotional material or other professional equipment into member countries without paying customs duties. Carnets are commonly used for trade show materials. The carnet, which is a Customs document, permits the holder to carry or send merchandise temporarily into certain foreign countries for display, demonstration or similar purposes without paying duties or posting bonds. Not all countries are members of the ATA carnet system. Economy specific requirements can be found in the individual economy sections of this manual.



### ■ **Harmonized Commodity Code**

This is a standard statistical classification system for imported and exported commodities. It is used to collect import/export statistics and to levy customs duties.



**■ Shipper's Certification for Live Animals**

When shipping live fish, International Airline Transportation Association (IATA) rules call for the filing a Shipper's Certification for Live Animals in duplicate.

	<b>Documentation</b>	
<b>SHIPPER'S CERTIFICATION EXAMPLE (Front)</b>		
 <b>SHIPPER'S CERTIFICATION FOR LIVE ANIMALS</b> <i>(to be completed in duplicate)</i>		
<p>This is to certify that <i>(check appropriate box)</i>:</p> <p><input type="checkbox"/> In addition to having completed all advance arrangements, this consignment is properly described and packed, and is in proper condition for carriage by air according to the current edition of the IATA Live Animals Regulations and all applicable carrier and governmental regulations. The animal(s) of this consignment is (are) in good health and condition.</p> <p><input type="checkbox"/> Animals taken from the wild for shipment have been appropriately acclimatised.</p> <p><input type="checkbox"/> This consignment <i>does not include</i> Appendix I species as described in the Convention on International Trade in Endangered Species of Wild Fauna and Flora or in other applicable national legislations. Applicable permits/certificates are attached to the air waybill.</p> <p><input type="checkbox"/> The endangered species contained in this consignment can be legally carried and imported into the country of ultimate destination and through the transit countries en route.</p> <p>The shipper accepts that carriers will not be liable for any loss, damage or expense arising from death due to natural causes, or death or injury of any animal caused by the conduct or acts of the live animal itself or of other animals, such as biting, kicking, goring or smothering, nor for that caused or contributed to by the conditions, nature or propensities of the animals. In no event will carrier be liable for death or injury to an animal attendant caused or contributed to by the condition, conduct or acts of animals.</p>		
<b>Number of Package(s)</b>	<b>Specific Container Requirement Number (see IATA Live Animals Regulations)</b>	<b>Species (description and names — scientific and common) and Quantity of Animals</b>
Name and address of shipper ..... Signature of shipper..... Date..... <small>Year/Month/Day (See reverse side for special conditions)</small>		Shippers failure to comply in all respects with the applicable IATA Live Animals Regulations and any other international and/or national government regulations, may be in breach of applicable law and subject to legal penalties.
Air Waybill No.	Airport of Departure	Airport of Destination
<p><b>Note:</b> Recommended size: ISO Standard A4.</p>		

### ■ **Insurance Certificate**

If the seller provides insurance, the insurance certificate states the type and amount of coverage. When the seller is quoting a C.I.F. (cost, insurance and freight) price for the product, it is understood that he or she is providing insurance coverage for the shipment from the time it leaves the vessel/plant/farm to the time it is delivered and accepted by the buyer.

### ■ **CITES Certificate**

The Convention on International Trade in Endangered Species of Wild Fauna and Flora (CITES) is an international treaty that has been in effect since 1975. CITES is the only global treaty focused on the protection of plant and animal species from unregulated international trade.

There are three appendices comprising CITES: Appendix I, which protects threatened species from all international trade; Appendix II, which regulates trade in species not threatened with extinction but which may become threatened if trade goes unregulated; and, Appendix III, which gives countries the option of listing native species already protected within their own borders. Relevant sections of the CITES Appendices are included in the Appendix of this document.

Currently, there are 143 member economies committed to the principles established by CITES. In particular, that any trade in protected plant and animal species is sustainable and that there is a process through which member countries work together to ensure that wildlife trade is carried out in accordance with the treaty. The CITES administrative body is headquartered in Geneva, Switzerland, providing original CITES documents in three languages: English, French and Spanish.

The People's Republic of China (Hong Kong), Singapore, the Republic of Korea, the United States of America and Japan are CITES members.

There are a number of bony fishes and molluscan species, most of which are not commercially viable, that fall under CITES Appendix I or II. However, it is advisable to double check with APEC member economies' Customs agencies to ascertain which species are included in the listings. For reference, the species listings can be found in this manual's Appendix. Species listings can also be found on the U.S. Fish and Wildlife Internet site: <<http://www.fws.gov/~r9dia/cites.html>>.

For Appendix II species, a separate export permit must be issued for each shipment and the scientific authority from the exporting country must have advised a management authority that export will not be detrimental to the species in the wild. For some species, an aquaculture certificate can be issued. For those economies not a party to CITES, such as Taiwan, but that trade with CITES members, a competent authority can issue documentation comparable to CITES certificates. Some economies have additional regulations in addition to the CITES certification. Check with the importer or the competent authority in the economy to which the product is being exported.

### **13. PACKAGING FOR THE GLOBAL MARKET**

Proper packaging for air cargo shipment is essential for important economic reasons. The better the condition of the product upon arrival, the greater the net returns and the more solid the supplier's reputation becomes in the marketplace.

There are other specialized packaging systems available in addition to those that are described in this manual. It is best to check with both the air cargo carrier and the importer/buyer to determine if the packaging system selected is acceptable. Also check with the air cargo carrier to determine if there is a weight limitation on unit packaging.

Packing and packaging for the export market is similar to the process for domestic sales. But, as is true for domestic shipments, export market shipment packing and packaging requirements will vary according to the type of product, type of market and method of shipment. Packing materials used on airlines must withstand leakage, vibration, shock, stacking and changes in temperature and atmospheric pressure.

Proper packing is indispensable to maintaining both the products' freshness and the customers' satisfaction. Insulating materials can help to maintain temperature. If the product tends to leak liquids, it should be packed with an absorbent pad in polybags. Absorbent pads help to remove liquid drip which can be a medium for bacterial growth.

Sellers know their product's attributes best. It must be assumed that no one on the way to the buyer truly understands the product as well as the seller. If the seller packs the product, assuming that it will probably be mishandled during its journey to the buyer, the properly packed product may still retain its quality and integrity.

Packing materials should be strong enough to withstand rough handling and temperature abuse but as light as possible to reduce shipping costs. Outer packaging materials should be multi-walled, wax impregnated fiber board/cardboard boxes with fan folded corners. Boxed product should be banded at least twice for added strength. The best quality boxes have reinforced corners.

For the overseas air transport of chilled goods, heavy corrugated or solid fiberboard cartons or sturdy expanded polystyrene boxes lined with polybags are generally used. Boxes that are wax saturated, wax coated or treated with some other water resistant process are desirable. In addition to preventing water leakage, these boxes also have greater strength when wet. The combination of a corrugated box and a molded foam box is a commonly used seafood packing system. Both expanded polystyrene and fiberboard have a high rate of breathability and allow for a certain amount of air exchange. However, for certain species, ventilation holes are suggested. See Section Two for product specific information.

For some markets and products, wooden crates are preferred (for products such as, sea urchin roe, crabs, tuna). For environmental reasons, some countries have begun to limit expanded polystyrene use. Other countries have set up recycling centers to handle expanded polystyrene. Some countries encourage the use of reusable boxes. However, reusable boxes result in additional costs in returning boxes to shippers. Most products should be enclosed in a polyethylene bag to prevent leakage. Often goods are double-bagged. The minimum thickness of the polybag should be at least 4 mm. Some airlines require a thickness of 9 mm.

Packaging for air shipments should be light, leak-proof and able to withstand rough handling. The wall thickness in expanded polystyrene boxes varies from 15 mm in a 6-kilo box to 19 mm in a 10-kilo box to 25 mm in a 25-kilo box. Wall thickness not only provides additional insulation but also strengthens the box. Some airlines have specifications on the wall thickness required for the size of the box. Certain airlines will not accept expanded polystyrene boxes more than 25 kilos without an outer carton. The major disadvantage of polystyrene is breakage if handled roughly. These boxes are difficult to clean and can create disposal problems.

Corrugated fiberboard boxes are economical, shock absorbent and easy to handle but are neither waterproof nor water-repellent unless they are specifically treated. The thickness of the corrugated wall depends on the weight of the box being shipped. Some general guidelines for minimum wall thickness are:

- ! Less than 10 kilos in weight, 4.8 mm. wall thickness.
- ! 10-20 kilos in weight, 7.0 mm. wall thickness.
- ! More than 20 kilos, double wall plus outside support

Wet-lock boxes are often used for seafood shipments. These boxes have a multi-walled construction and a wax-impregnated or waterproof coating on both the inside and outside of the box. Wet ice is usually not advised for inner packaging materials and some air cargo carriers restrict its use. Instead, wet newspapers or rags will provide the needed damp environment. Although wet seaweed can be used, it sometimes gives off noxious gases as it decays. If wet ice is used as a coolant, it should be sealed in polybags.

It is important to check with the air cargo carrier of choice prior to selecting packing materials. Some air cargo carriers will not accept polystyrene. Others will only accept pre-approved containers. Some require an absorbent pad in addition to a leakproof container. There can also be weight limits on the container. Some carriers prefer a gross weight of 27.7 kilos (60 pounds) to 36.36 kilos (80 pounds) for each container. Many carriers also require a top loading capacity of at least 227.27 kilos (500 pounds). It is wise to check with air cargo carriers for their specifications well in advance of preparing the product for shipment or even before the shipping boxes are purchased.

Check with the importer/buyer to determine whether there are any in-country regulations prohibiting the use of disposable packaging and containers. The major drawbacks to the use of returnable containers are the high cost of initial purchase, the cost of returning empty containers and maintenance costs.

The shipper cannot afford to have fresh/ live fish and seafood rejected either at the airline or in the Customs clearance process. Returning products to the plant for repacking can result in excessive delays, added expense, the loss of quality and the loss of a sale. In some countries, product that is rejected by Customs officers will be moved into refrigerated storage and held at the buyer's expense. *This means that costs are rising while product quality and value are decreasing.*

### ■ **Insulation**

Insulators slow the penetration of heat into a package. The proper combination of insulating materials and coolants will help to maintain a low temperature for the product and, thereby, aid in the maintenance of product quality. The insulating abilities of materials are additive. A packaging system that includes both an expanded polystyrene box and a fiberboard outer carton would have superior insulating capability.

Many insulators lose their effectiveness when they become wet. Therefore, when designing a packaging system, consider the use of polybags to supplement fiberboard and expanded polystyrene to restrict moisture saturation of the insulator.

The following insulating materials are often used for seafood shipments. They are listed in descending order of their ability to insulate:

1. Urethane Foam.
2. Expanded Polystyrene.
3. Shredded paper.
4. Double-walled corrugated fiberboard.

### ■ **Expanded Polystyrene (Styrofoam)**

Expanded polystyrene (EPS) boxes are widely used in the fish and seafood industry. These boxes provide excellent insulating capability but are bulky, can be broken by rough handling and disposal can be costly. In the case of expanded polystyrene the thicker the wall of the box, the better the insulation. Expanded polystyrene is not waterproof. Many airlines suggest that expanded polystyrene be used in conjunction with a fiberboard box. The United States Department of Agriculture has approved expanded polystyrene for food uses.

Some expanded polystyrene systems consist of stackable trays with drainage holes. This system reduces compression on the product and allows constant washing. As the ice melts, it washes away surface bacteria. This system also drains drip loss and minimizes growth of bacteria on the product. Liquids drain into the bottom unit of the stack.

### ■ **New Insulating Materials**

There are new insulations available that not only have better R factors, but are also reusable. These new insulators help extend product life and, in some cases, reduce freight costs since they lessen the volume of packing. In determining the type of insulation to use, it is usually wise to assume that the product will spend at least 24 hours outside of a refrigerated environment at some time during the shipment process. New lightweight insulating materials use a metallic surface to reflect almost all radiant heat (97%). This effectively reduces the thickness of the insulating material. The ThermoGard system consists of a metallic plastic bag in which the product is packed, a bubble pack insulating wrap and a leak-proof carton. Another system, Stratech aluminum boxes have a wall thickness of only 5 mm and, supposedly, have the same insulating properties as expanded polystyrene boxes with a 30-mm wall thickness. These are only a few of the new systems on the market.

Bubble pack insulating materials have become increasingly popular because, unlike expanded polystyrene, they can easily be broken down. Bubble wrap is flexible and can be wrapped around products which adds to its usefulness. The combination of the air pockets in the bubble wrap combined with a foil layer effectively reflect almost all of the ambient heat. These systems are also reusable.

### ■ **Coolants**

The shipper should check with the air cargo carrier for the list of acceptable coolants. Some airlines have limits on the amount of coolant per pack especially when the coolant is dry ice and many require preapproval for the use of dry ice. (See section on “Dry Ice”). Sufficient coolants should be used to ensure that product can go unrefrigerated for 72 hours. Wet ice is often discouraged or prohibited because it is messy and highly corrosive to aircraft. If wet ice is used, an absorbent pad should be included in the bottom of the carton to absorb water as the ice melts. In almost all cases, absorbent pads should be included in seafood shipments to absorb drip loss which can be considerable during shipment. When wet ice is used, it should be packed in sealed polybags.

Dry ice (solid carbon dioxide), although effective, evaporates leaving empty space and creates a hazard to living animals in close proximity because it displaces oxygen. Because of its extremely low temperature (-78.9°Centigrade), to avoid freezer burn, dry ice should not come in direct contact with product. Use of dry ice is not recommended with any container that is airtight. If a gas impermeable barrier bag is used, dry ice should not be used. In most cases, dry ice must conform to IATA Dangerous Goods Regulations and Series 45-11. In the United States, the net weight of dry ice must be marked on the outside of each package in which it is used. This allows carriers to monitor the quantity of dry ice in the hold. The international identification number for dry ice is UN 1845. Dry

ice usually requires preapproval by the air cargo carrier. And some airlines prohibit the use of dry ice entirely. Check with the airline. The limit on dry ice also varies with the type of aircraft used on a particular route.

The major advantage of using gel packs is that all the liquid is bound, therefore reducing the danger of leakage during thawing. Because gel packs maintain a relatively constant volume, they also lessen the possibility that product will shift during transit. A nontoxic gel pack is preferable since there is always a possibility that the pack could rupture. This can be a problem when shipping fish and seafood with spines or hard, rough shells.

#### ■ **Modified Atmosphere Packaging (MAP)**

In Modified Atmosphere Packaging (MAP) air is replaced by other gas mixtures usually carbon dioxide or nitrogen. These gas mixtures help to inhibit the growth of microorganisms and reduce oxidative reactions that may lead to product rancidity. Product is not preserved and still must be kept under refrigeration. The costs of this technology make it cost effective for only high value products.

Sometimes gases such as carbon monoxide are used to preserve color in species such as bluefin tuna. Such treatment is illegal in certain markets. Check with the importer/buyer.

Because of the absence of oxygen, MAP and vacuum-packed fish and seafood products have an increased risk of botulism growth and must be kept below three degrees Centigrade.

## **4. PACKING FOR THE GLOBAL MARKET**

#### ■ **General Information**

In most cases, products should be packed tightly, leaving only enough room for coolants. Gel packs are generally preferred because they last longer, are reusable and do not create empty space as they melt. Empty space allows products to shift which may result in physical damage. However, care must be taken to not over-pack. For example, when packing a high quality product such as fresh, bled flatfish for the Japanese market, compression of the fish must be avoided. In this instance it is better to pack fish in smaller boxes.

Coolants such as gel packs, dry ice and wet ice sealed in polyethylene bags should be placed along the bottom and at the top of the container to absorb heat from the outside. Poor placement of coolants greatly reduces their efficiency. It is essential to avoid hot spots in the packaging. When determining the amount of coolant to use, it is important to consider the volume of product that is being shipped.

Avoid product over chill. Do not allow the gel pack to touch the product directly. Newspapers

or other similar material can be used as a baffle between the coolant and the product. In addition, placing coolant in the top of the shipping crate can set up a counter current exchange where cold air sinks to the bottom of the carton and warm air rises. As the warm air rises, it cools and sinks, thereby maintaining product temperature.

Boxes should be able to withstand being packed five units high. Almost all air cargo carriers require a minimum of two bands on each box.

Fish and seafood shipments should include an absorbent pad that can leach liquids away from the product prevent leakage. Some absorbent pads are treated with gel agents that bind water as it drips away from the product. These gelling agents not only absorb water but can reduce odors and retard bacterial growth in some instances.

### ■ **Shipping Live Fish and Seafood**

In addition to the normal packing requirements, there are also ethical problems involved with the shipping of live fish and seafood products. To avoid potential criticisms, it is generally a good idea to employ a code of practice that deals with care and handling issues when shipping live product.

When shipping live fish and seafood, there are a number of species specific factors that must be considered to ensure that the product arrives alive. These factors include: 1) respiratory rates; 2) ability to handle stress; 3) excretory functions, and; 4) temperature tolerance ranges.

Reducing the metabolic rate of the live product can significantly increase the viability of the shipment. Metabolic rate reduction can be accomplished in two ways: 1) use of an anesthetic; or 2) reduction of temperature. Anesthetic use is not approved for food fish and seafood in most markets. Even if anesthetics are approved for food products, the purge period (to rid the product of the drug) would probably be greater than the usual pre-purchase holding time in the final market. Trials are now underway where natural substances are used as anesthetics and some have proven successful.

Oxygen requirements for live fish and seafood are related to: 1) body size; 2) ambient temperature; 3) nutritional state, and; 4) metabolic rate. Oxygen consumption increases with temperature, body size and activity level. Diurnal rhythms also affect oxygen demand. Handling and packing procedures should be designed to keep metabolic rates at a low level. In most cases, this can be accomplished by reducing temperature and eliminating feeding for several days prior to shipping. The optimal time to cease feeding varies depending upon the species. Feed reduction schemes should consider product weight loss in order to ensure that the product condition remains prime.

The maximum oxygen content in water is five to ten ppm. Generally oxygen consumption by animals is estimated to be between 10 and 1,000 milliliters per hour per kilo. Saltwater fish are less efficient at using oxygen than freshwater fish and therefore more susceptible to oxygen depletion. Oxygen consumption doubles or triples for every ten degree rise in water temperature. At the same time,



quantities of oxygen dissolved in blood and water are higher in lower temperature water. These factors combine to make maintaining low temperature a critical issue when shipping live fish and seafood. When shipping during the warmer months or when shipping to warmer climates, the quantity of fish per carton should be reduced. If products will require re-oxygenation, check with the airline to see if this is possible.

During shipment finfish discharge large quantities of ammonia compounds as final metabolic products. Ammonia becomes dissolved in the water and is difficult to remove. In high concentrations, ammonia can be toxic. When dealing with live finfish shipments, consider the amount of ammonia discharged in relation to the amount of water in the shipment.

For shipping long distances, there should be sufficient oxygen to allow the product to survive for 48 hours from the time of acceptance by the airline.

Live shellfish shipments need ventilation during shipping, therefore, shipping containers should not be sealed. Some packaging systems include ventilation holes near the top edge of the shipping carton.

Specialized shipping systems are available for particular types of fish and seafood. For example, new packing for lobsters includes a system in which each lobster is placed in a separate compartment. This system prevents lobsters from fighting. Therefore, they consume less oxygen and physical damage is reduced. Although such specialized packaging may be more expensive, check the weight of packing. There may be savings in shipping costs that can offset the more expensive packaging. Reduction in mortality can also offset higher packing costs.

Some of the bulkier, specialized shipping systems should be loose shipped. If product is to be shipped in an airline supplied container such as an LD3, consider the volume of the packing. Shippers who use Unit Loading Devices usually reject bulky packs that handle only a small number of lobsters because they cannot pack a sufficient number in an air line supplied container.

## ■ E TYPE CONTAINERS

Seafood products are often packed in E type containers. “EH,” “E” and “EO” containers are shipper supplied corrugated cartons that are standard in the airline industry. They are available from most box companies

■ **Unit Loaded Devices (ULDs)**

Unit Loaded Devices (ULDs) by the airline. Not all routes or

are shipping containers provided all airlines supply the same ULDs. They are available in a variety of configurations. Some

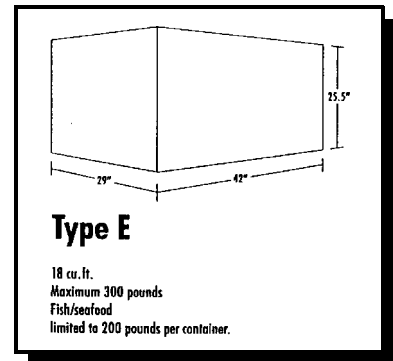
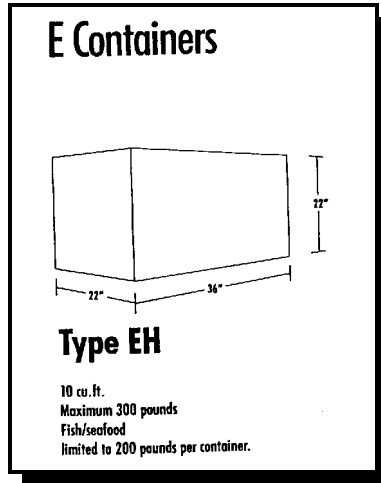
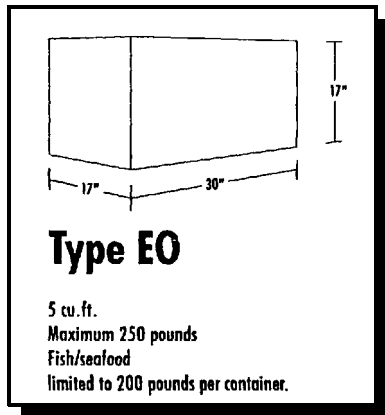

airlines pack all seafood in

ULDs.

Usually the airline can provide information on the temperature range that can be maintained within the ULD. A few ULDs are refrigerated. Others (Envirotainers) use dry ice with a fan to circulate the air. However, most airlines will not guarantee that a constant temperature will be maintained.

When using airline supplied containers, it is important to allow for air circulation around the product. This may require the use of a pallet to allow air to circulate under the product. It is also important to allow headroom and to keep product away from the walls of the container. Generally the ULD should be lined with a polyethylene sheet and absorbent pads.

Weight should be evenly distributed within the ULD. Heavy objects should be placed at the bottom and toward the edges of the unit. Lighter objects should be toward the center and top. It is also important to arrange boxes so that labels are visible in order to facilitate sorting.

Some packaging companies produce specialized packing systems designed to fit into the configuration of a ULD. This allows shippers to maximize the use of space within the unit.

■ **Marking and Labeling**

Shipping cartons should be labeled properly and legibly to reflect the contents and the handling instructions: **“Perishable--Fresh Seafood”** **“Perishable--Live Seafood”** and **“this end up.”**

**Clarity in shipping instructions regarding refrigeration is crucial.** Too often, product is ruined because it is placed in a freezer rather than a coldstore. Workers in the final shipping destination may not clearly understand the labeling. Use graphic symbols, for example, the *freezer penguin* with a slash through it to prevent a product from being placed in a freezer rather than a coldstore. Indicating legibly via graphics and in the appropriate languages on the package that the product should be kept under refrigeration and should not be frozen is critical

Cautionary marks should also be used. Use of internationally recognized symbols in addition to the word "**perishable**" will help to ensure that the buyer receives the product in the best possible condition.

However, because of liability issues, some airlines will not accept packages that have external refrigeration/freezer markings or that indicate on the air waybill that product should be kept under refrigeration. These airlines are concerned that products will not be refrigerated at either the point of origin or the final destination and do not wish to assume the liability. When shipping fresh or live products, such regulations should raise a red flag and cause the shipper to reconsider using that particular airline.

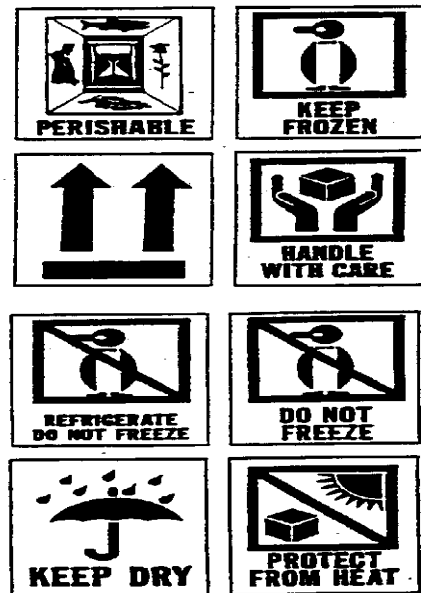

*Markings Used In International Trade*

To assist the selected air cargo carrier in transporting products to their final destination, identification marks should be used on each package. These marks should include:

- ✈ Country/Region of origin.
- ✈ Gross and net weight (in kilos and pounds).
- ✈ Number of each package, size of case.
- ✈ Port of entry overseas.
- ✈ Shipper and receiver.
- ✈ Final destination and order number.

If not preprinted on shipping cartons, markings should be written in waterproof ink and should appear on three sides of the container, preferably on the side and/or ends and top.

“This side up” and “Perishable” labeling should be affixed to the outer packaging along with ISO 9000 “Arrows.”

■ **Special Marking Requirements for Dry Ice**

The net weight of dry ice (solid carbon dioxide) must be marked in a specific format, including the UN identification code, on the outside of each package in which it is used as a refrigerant. This allows air cargo carriers to monitor the quantity of dry ice in their holds. Such markings should read “Dry Ice 9, UN 1845, Net Weight 2kgIII”

The package should also bear the international black and white label indicating dry ice. The label should be placed near the dry ice identification markings. This label must be at least 10 cm X 10 cm.

■ **Product Identification Markings**

It is recommended that shipments be identified on the outside of the container with the common name of the species such as “Perishable - Fresh Salmon” or Perishable - Live Lobsters.” The scientific name should also be included, if available.

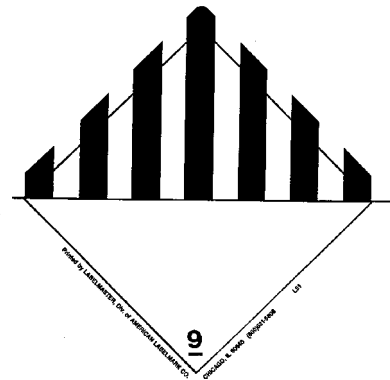

## 5. AIRLINES AND AIR CARGO CARRIERS

■ **General Information**

Most international airlines maintain an overseas freight (air cargo) division. These airline companies are generally experienced in shipping samples, live product, or high value relatively low volume fresh product. Depending upon the airline, products may be shipped on either a freighter or a passenger flight. Some airlines will not handle live products at certain times of the year because of the ambient temperature at either the point of embarkation or arrival. Just because a carrier handled product at one time does not mean that it will handle that same product at another.

Because fish and seafood is a highly perishable commodity, it is important to select an air cargo carrier that is familiar with the product and has a demonstrated commitment to shipping and properly handling fish and seafood.

Potential temperature abuse problems can exist aboard the aircraft itself, in holding areas and on the tarmac. Air cargo carriers must also be cognizant of the handling and placement of the more fragile products such as lobsters within the cargo hold. Reliability and transport time can be higher priorities than price when selecting an air cargo carrier. This is especially true when shipping live products.

Some airline companies are more prone to bump fish and seafood from flights than others. Therefore, it is critical to investigate the reliability of the carrier. Airlines have a variety of rates based on either Specific Commodity Rates (SCR) or Container rates. Narrow body aircraft only carry bulk loaded cargo so rates tend to be SCR or there may be rates for "EH" and "E" containers (which are shipper supplied corrugated containers standard in the airline industry).

Cargo rates change often and there are many "special rates" available. Always check with airline companies to determine the best rates. Some airlines offer special rates when products are extremely perishable. These rates are considered "confirmed--must ride." They offer a protection against bumping and may be worth the higher cost. A listing of air cargo carriers servicing the selected economies is included in the appendix.

There can be specific problems when shipping out of or through very warm climates. Hot weather can trigger weight restrictions which sometimes necessitate the bumping of cargo. Check with the airline to determine the priority level for fish and seafood cargo. Most air carriers can provide a range of temperatures that will be maintained within the cargo hold. This varies by type of plane and position of the cargo on the plane. Different zones have different temperatures.

To select the best air cargo carrier for shipping fish and seafood to a particular economy, draw up an airline schedule requiring minimum handling over the shortest shipping hours. Determine air cargo charges by weight for flights from several different airports. Special, lower rates for food are sometimes applied to shipments from certain airports. Freight forwarders can assist with this and also provide support services for preparing export documents, such as the commercial invoice, packing lists, air waybills, etcetera.

To avoid delays, schedule the product to arrive at the airport in ample time prior to the designated flight. Some airlines require that product arrives a certain number of hours prior to departure. Many will not accept a last minute delivery. Make sure that all shipping documents are in place. Fish and

seafood are fragile commodities and must be handled with care throughout the shipping process. Temperature abuse is the single greatest factor in loss of quality in fish and seafood products.

Check airline flight schedules carefully to help ensure that the product arrives promptly and in good condition. Although many Asian companies operate for a half day on Saturdays, most buyers prefer products to arrive on Monday or Tuesday. That provides the maximum amount of time to sell the product. Product arriving on a weekend or a holiday may not clear Customs in a timely fashion or may incur additional overtime expenses that contribute to the cost of the shipment.

Many airlines surveyed in the preparation of this manual identified late delivery for outgoing shipments and late pick-up of incoming shipments as major problems when handling fish and seafood. Most airlines have a specific delivery window during which they would like products to arrive for outgoing flights. This provides sufficient time to check the packaging and documentation, and to make sure that the product is loaded onto the aircraft correctly. Late pick-up was also identified as a problem. Because fresh and live seafood products are so fragile, it is critical that they move through the transportation chain as rapidly as possible.

Given current levels of competition among airlines, it is critical to shop for the best possible routes and rates. It is absolutely essential to determine how many stops the plane will make prior to reaching the cargo's final destination. Be advised that the term "direct flight" does not mean nonstop. Check to see how many stops the flight will make if any. How long will the aircraft remain on the ground? While the aircraft is on the ground, cooling systems are not operational. Determine how long the layover will be, if the cooling system shut down will negatively affect product quality, and if so, select a different flight.

In an effort to maximize efficiency, many airlines are now offering "tail to tail" service where cargo is moved directly from one plane to another. This type of service can offer improved transit times, less exposure to the elements, and lower costs. "Tail to tail" service can allow shippers to take advantage of less crowded routes. With limited cargo space, the more popular routes are often sold out. When all cargo space is sold out on popular routes, some shippers opt to airship the product into an airport near the final destination and transport it the rest of the way over the road.

When shipping live fish and seafood products, inform the airline that your product needs air and a pressurized compartment. Make sure that each box is marked "**Live Seafood**" in large letters.

Some airlines have very specific acceptance requirements for fish and seafood products. Check with the airline. Almost every airline that accepts fish and seafood for shipment has regulations that must be followed if the product to be accepted for transport. Unfortunately, many of these airlines do not have published written requirements. If the supplier selects an airline that does not supply written shipping directions, then it is incumbent upon the supplier to work closely with the airline's cargo office to make sure that the product is packed and packaged in an acceptable fashion.

## ■ **Claims**

Every effort is made by the air carrier to meet delivery needs and arrival notification within operational constraints. However, if an unforeseen delay or other problem results in a delayed shipment a consignee should be prepared to take delivery and remember that settlement procedures

exist for the resolution of any claims following final delivery of cargo. **Where there is a potential for loss, all relevant records should be kept.**

## ■ **Temperature Recording Devices**

Relatively inexpensive time/temperature loggers that can determine where in the distribution chain temperature fluctuations may have occurred are available. These devices are generally used for perishable, high value products that must travel. Both single use and multiple use indicators are available.

In a few cases, these devices have been used in legal proceedings when there has been dispute regarding handling and product quality. However, there are no established legal rules for the use of these records. When time/temperature loggers are used, most disputes are settled out of court.

## ■ **Insurance**

For exporters shipping F.O.B. (free on board), F.A.S. (free alongside) or C.&F. (cost and freight) where payment terms are Open Account, Collection by Draft, or any other method which requires payment after release of goods, the exporter is exposed financially if the:

- ! Buyer neglects to insure.
- ! Buyer's insurance has limited coverage and an uninsured loss occurs.
- ! Buyer does have insurance when a loss occurs, but receives claim payment for their insurer in local currency, exposing the exporter to a potential loss from fluctuations in exchange rates.
- ! Buyer rejects goods as not being in sound condition, but physically no damage occurred during shipping. This would leave the exporter with a financial interest in unclaimed goods located hundreds to thousands of miles away.

For these reasons, it is in the exporter's best interest to ship CIF (cost, insurance, freight). Shipping CIF will allow the exporter to:

- ! Tailor the insurance program to meet the exporter's specific needs. The exporter cannot always rely on the overseas customer to hold the exporter's contract.
- ! Ensure all shipments are automatically covered subject to the terms of the exporter's contract.
- ! Ensure rates are competitive based on the exporter's shipping experience, not the buyer's.
- ! Ensure claim payments are in the country of origin's currency, and that negotiating and settling claims can be accomplished locally with an insurance agent of choice.

If it is obligatory that the buyer insures imports domestically, contingency coverage can often be provided by the exporter's local insurance carrier to pay for losses should the buyer's policy not cover them.





## SECTION TWO: PRODUCT SPECIFIC INFORMATION

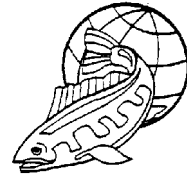

### 1. FRESH FINFISH

To maintain finfish freshness and quality during the shipping process, transportation space, speed and temperature control are critical. Finfish and shipping materials should be pre-chilled to help maintain a low temperature. In addition, finfish should not come in direct contact with coolants since this may cause the product to become freezer-burned.

#### **When considering shipping fresh finfish, remember:**

- ! Coldwater finfish spoils more rapidly than warmwater finfish.
- ! Larger finfish have a better shelf life than smaller finfish of the same species.
- ! The higher the fat content of the finfish, the faster it spoils.
- ! Round finfish spoils more rapidly than flat finfish.

When developing a shipping and packing strategy, consider the temperature at the final destination. In general, fish and seafood shipments often spend time on the tarmac, exposing them to the ambient temperature and weather conditions. Therefore, pack accordingly.

Higher quality fresh finfish, still in rigor mortis, is often sold as a premium product and commands higher prices especially at auction. To preserve this quality, live finfish should be dispatched quickly, bled thoroughly, cleaned well and sufficiently chilled prior to packaging for shipment. This is commonly done by breaking the spine by the neck and bleeding the finfish by cutting at the base of the pectoral fins to sever the veins along the lateral line and at the tail (the caudal peduncle). Reportedly, chilling to between minus three and zero degrees centigrade preserves the best quality.

#### **■ Fresh Tuna (also applicable to swordfish and other large fish)**

Large tuna are often packed in a wooden crate or a heavy corrugated fiberboard box with a skid at the bottom. Expanded polystyrene or another insulating material is used to insulate the box. The box should then be lined with a polyethylene sheet. The tuna should be placed in a polybag or wrapped in a sheet of polyethylene with coolants packed into the oral and abdominal cavities. The polybag

or the polyethylene sheet should be sealed to avoid drip. Some shippers use a special green paper for high-priced markets. It is believed that this paper helps to preserve the quality of the tuna.

Some shippers suggest packing dry ice wrapped in a water absorbent material in the oral cavity and at the tail. Others recommend using a foam rubber sheet under the fish to protect it from physical damage. Shipping strategies are developed by trial and error.

The box should be completely sealed and up-arrows and perishable markings should be affixed prominently.

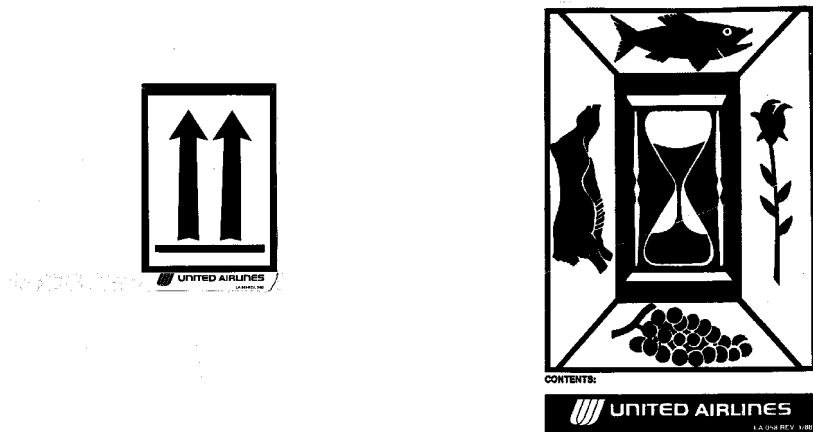

Smaller tuna can be packed in corrugated fiberboard boxes without the skid.

### ■ Fresh Flatfish

For some markets, especially the sushi and sashimi markets, flatfish can be bled using the “ike jime” procedure in which a cut is made toward the front of the flatfish severing the major artery and the spinal cord. Placement of the cut is made to preserve the greatest amount of flatfish flesh. This paralyzes the flatfish. A second cut is made in the tail to hasten the removal of blood. Flatfish are then chilled slowly to maintain circulation and facilitate the bleeding process. After the flatfish have been bled, they are transferred to a salt/ice water slurry and chilled to 12° Centigrade. Although flatfish are often packed in 13 kilogram net cartons, more expensive species can be packed in 8 kilogram cartons to avoid compression. Special nesting expanded polystyrene packing systems are also available. For many markets, product is best sorted by 0.5 kilogram increments.

Bleeding produces a desirable white color in the flesh and on the underside of the flatfish. When flatfish are not bled properly or are under stress, blood spots can appear on the white side of the fish during shipping. Because flatfish are graded depending upon the amount of blood spotting, careful handling to avoid stress and proper bleeding techniques can increase the price received for the product. Bleeding delays the onset of rigor and prolongs rigor once it has begun.

Another technique to avoid undue stress in flatfish while in transit employs a patented method of severing the spinal cord without severing the artery. This essentially prevents live flatfish from thrashing about in the shipping box.

Once the flatfish have been immobilized, they can be packed in a standard wet lock box lined with expanded polystyrene or in one of the new stackable expanded polystyrene systems. In these systems, flatfish are placed in shallow expanded polystyrene boxes with drainage holes in the bottom. Coolant is used in each of the boxes to maintain temperature. These boxes are then stacked (usually) three deep. The bottom box is a receiver for drip from the boxes above. Allowing for drainage helps to ensure that the flatfish are not packed in bacteria laden drip.

Survivability during waterless transport varies depending upon the species. After conditioning, some species can be packed simply wrapped in a damp cloth in a polystyrene box with gel packs and an absorbent pad. This eliminates the need for bleeding procedures.

Boxes are sealed with tape and placed inside a polyethylene bag. This side “up arrows” should be used to ensure that the product is handled properly throughout the shipping process.

## **2. LIVE FINFISH**

### **■ Specialized Transport Systems**

There are some specialized packing systems that employ an oxygen generator to oxygenate the fish during air transit, however, only a few airlines will accept such systems because of safety concerns. These systems have been successful in transporting fish for times in excess of 40 hours. Some of these systems include compartmentalized boxes in which each fish is held in a separate compartment. Others have a single compartment. The advantage of separating the fish is that it decreases the potential for physical damage resulting from interactions among the fish.

These systems often include:

- ! An air pump.
- ! An oxygen source.
- ! A carbon dioxide absorbing system.
- ! An oxygen diffusing mechanism.

Because there is a consistent source of oxygen and oxygen levels can be kept close to the saturation point while carbon dioxide is being removed, the amount of water required is greatly reduced.

If the system diffuses sufficiently high volumes of oxygen into the water, carbon dioxide can be stripped. Some systems rely on carbon dioxide absorbing mechanisms while others simply have a

very efficient oxygen diffusing system that forces carbon dioxide out of the water. This allows for better oxygen saturation.

The major drawback to these systems is that many airlines will not carry oxygen generators.

### ■ **Breathing Bags**

Breathing bags are made of specialized membranes that allow for the exchange of air and carbon dioxide. This eliminates the need for using pure oxygen in the shipment. Air space is not needed in the shipping bag since air moves freely from the surroundings into the bag while carbon dioxide diffuses out. The higher the temperature of the water, the better the breathability of the bag. Bags can be doubled and heat sealed, and still function efficiently. If a number of bags are packed in the same carton, the bags should be separated by cardboard or newspaper. This allows them to breathe efficiently. Bags can be reused. The major drawback is the initial cost of the bag compared to standard polyethylene bags.

### ■ **Standard Shipping Procedures**

Shipping live freshwater and saltwater finfish requires the shipper to thoroughly understand the physiology and special needs of the product. Paramount to ensuring that the product arrives alive is the selection of only high quality, good condition product for shipment. IATA regulations prohibit travel times more than 48 hours for live fish.

Shipping procedures will vary depending on the time of year and climate into which product is being shipped. During the warmer months, the quantity of finfish shipped per carton should be reduced anticipating a higher oxygen demand by the finfish.

**Controlling temperature and shock is absolutely critical** to ensuring that the product arrives in good condition. A way to reduce finfish stress and shock, is to acclimate the product prior to shipping. One method frequently employed is slowly reducing the product's internal temperature. How rapidly this can be accomplished is species dependent and is best determined through trial and error with the target species. The lowering of temperature is accompanied by a reduction in metabolic rate until the finfish reach a state of pseudo-hibernation. Pseudo-hibernation helps reduce stress thus providing better quality and more valuable end products.

Some finfish species require slow acclimatization to temperature reduction while other species can be chilled rapidly. There is an upper and lower temperature tolerance for different species. These limits can change depending upon the environment and season. It is incumbent upon the shipper to know the product's limits and to acclimate the finfish accordingly.

Economy dictates that water weight should be reduced in the shipping container. However, reducing water amounts can lead to inherent problems such as:

- Insufficient oxygen - saltwater finfish use oxygen less efficiently than freshwater finfish.
- Carbon dioxide build-up.
- Detrimental changes in pH level.
- Detrimental temperature changes.
- Build-up of fish discharges.
- Loss of finfish surface mucus.
- Physical damage and/or mortality.

Discharge build-up coupled with finfish surface mucus loss can cause increased bacterial levels resulting in clogged gills and respiratory interference. Physical damage, whatever its cause, will make finfish more susceptible to bacterial infection. This reduces the product's commercial value and/or can lead to high mortality levels. Because of these factors, it is critical not to overcrowd a shipment.

When packing in water, water quality must be considered. Depending upon the water source, there can be problems with chlorine, heavy metals, pH and lack of beneficial electrolytes. If problems are encountered, it may be feasible to check the quality of the water in which the fish are shipped. During shipment, the fish are under stress and this can exacerbate any water quality problems.

Temperature regulation is critical in the successful shipping of live finfish. Species vary in terms of temperature tolerances and the ability to withstand extended shipping times ***Remember that during travel, the temperature cannot be lowered. All that can be done is to maintain the original temperature of the shipment.*** Finfish should be acclimated to the lower traveling temperature prior to packing. The shipping box and packing material should be pre-chilled prior to adding the finfish.

While it is important to avoid temperature increases it is also important to avoid or reduce the over-chill of a product. If insulation is inadequate, product can become over-chilled when shipping into or through regions with very low ambient temperatures. If coolants such as gel packs and dry ice come into direct contact with the finfish they can cause physical damage or over-chilling. Wrapping gel packs in newspaper is one method employed to avoid this potential problem.

Generally, placing gel packs into the transport system prior to adding the finfish is recommended. Some researchers recommend placement along the sides of the packing box while others place the

gel packs in the top of the box. Placement in the top of the shipping box can set up a countercurrent exchange system where cold air sinks and flows over the fish and hot air rises where it is chilled by the gel packs. Placement along the sides of the packing box reduces heat exchange from the ambient temperature outside the packing box.

Depending upon the species and its particular requirements, finfish can be packed wrapped in wet cloths, in damp polyester batting, or in a polyethylene bag with a small amount of water. Water should be limited to a maximum of one quarter to one third of the bag capacity. Some species, such as live adult eels, require even less water. Depending upon the species, some fish require total submersion in water while others simply need a very humid environment. In some cases, air should be vacuumed out of the bag and replaced with pure oxygen. Again, this is species dependent.

Finfish oxygen consumption doubles or triples for every 10 degree rise in temperature. At lower temperatures, dissolved oxygen in the blood and water is greater than at higher temperatures. Low temperatures also reduce finfish metabolism. In addition, fewer waste products will be produced by the finfish during low temperature shipment. To reduce the production of finfish waste products during travel, feeding should be reduced or completely stopped prior to shipment. The number of days the finfish are on the restricted diet regime is dependent on the species. Feed reductions and stoppages should be balanced with weight-loss concerns.

For the reasons above, the quantity of finfish in the shipping container should be reduced during the warmer months or when shipping within and to tropical and subtropical climates where the ambient temperature is high. A disposable temperature recorder can be used to pinpoint places in the shipment time line where major temperature shifts can occur. The recorder will identify whether the shipper delivered the finfish at the appropriate temperature to the air cargo carrier and whether temperature abuse occurred during transit.

Some finfish species require the injection of pure oxygen while others can survive with natural ventilation. Generally the volume of oxygen injected is two thirds to three quarters of the bag volume. Lack of agitation during air shipping reduces the diffusion of oxygen into the water. Increasing concentrations of carbon dioxide in the water, as a result of metabolic processes, can depress the pH. Low pH increases the toxicity of carbon dioxide. Increased carbon dioxide also affects hemoglobin's ability to transport oxygen. Some species of fish will actually experience gill burn when breathing at the surface during transport in a pure oxygen environment. In case there is a delay during shipment, the bag should not be heat sealed. It should be twisted, looped, folded over and sealed with an elastic band. This will allow for re-oxygenation if significant delays occur. Air cargo carriers will not re-oxygenate the shipment unless special arrangements have been made in advance.

#### ■ **Shipment Markings/Labeling for Live Finfish**

Shipment markings and labeling should be in English in addition to language which may be required by importing or exporting country.

All live finfish shipments should be marked with at least one IATA live animal label and up arrows. Finfish should be packed to survive 48 hours transit time from the time of acceptance by the airline. The shipper should clearly print the acceptable temperature range in Centigrade and Fahrenheit on the outside of the box in which the finfish are packed. The time and date at which the finfish was packed should also be indicated. Again, remember:

- 1) All live finfish shipments should have at least one IATA live animal label.
- 2) The full name, address and contact number of the shipper, consignee and a 24-hour contact.
- 3) The scientific and common name of the finfish and quantity of each species contained in the container as shown on the shippers certification.
- 4) Up arrows on all four sides of the containers whenever possible.
- 5) Print acceptable temperature range in Centigrade and Fahrenheit on the outside of the box.

### ■ Special Packaging for Live Finfish

Double bagging is generally suggested. Spiny finfish should be placed in an inner container of hard plastic within a polyethylene bag separated from an outer polyethylene bag by several layers of paper. Only one species should be contained per bag. The inner bag should be filled with water to approximately one third of its capacity.

Add water and then fish. To inject oxygen, hold the oxygen tube at the bottom of the bag. Press out air from inside of the bag and bubble oxygen through the water. Blow more oxygen in to inflate the bag. Twist the top of the bag, fold it over and secure with an elastic band.

It is recommended that expanded polystyrene containers, sheets or other insulating material be used to maintain an appropriate temperature and to protect the fish from rough handling.

### **LIVE ANIMALS**

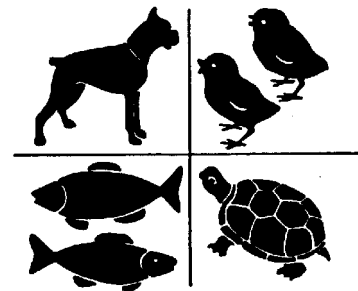

contents: \_\_\_\_\_  
**UNITED AIRLINES**  
LA 679 PRINTED IN U.S.A.

### **3. LIVE EELS**



Young eels should be packed in polybags filled with either freshwater or saltwater to one third of their capacity. After the eels have been added, pure oxygen can be injected. The eel bag should be filled only to about 60-70% of its capacity. The top of the bag should be twisted, folded over and sealed with an elastic band. The bag may also be heat sealed, however, this prevents re-oxygenation in case of an excessive delay. To help ensure the integrity of the product, double-bagging should be used. The outside container can be either expanded polystyrene or corrugated fiberboard. Adult eels can be packed in the same manner but the amount of water can be reduced.

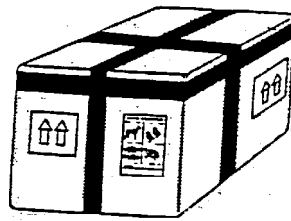
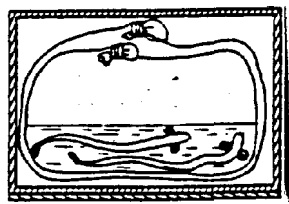

#### 4. LIVE SHRIMP

To preserve the structure of live shrimp (prawns) including claws, legs and antennae, they should be cooled to a temperature that achieves lethargy. Reducing the temperature to near the pseudo-hibernation point, makes handling easier and less stressful for the shrimp. However, if the shrimp is chilled too much, it will not survive. Unfortunately, the temperature at which the shrimp begin to die has not been identified for many species.

Chilling shrimp to near pseudo-hibernation has been used successfully for kuruma shrimp (*Penaeus japonicus*). These shrimp can withstand low temperatures. To avoid drastic temperature swings, kuruma shrimp are often harvested at night when the ambient temperature is lower. The shrimp are then placed in a seawater holding tank with a good aeration system. The temperature is lowered slowly. This is generally accomplished by adding ice sealed in plastic bags to avoid diluting the seawater. Some shippers reduce the temperature more rapidly and have had good results. The temperature threshold for pseudo-hibernation is dependent upon species, harvest area, and season. This process can take from four to six hours. In some cases, rapid chilling can cause loss of legs and, in prawns, the loss of claws. With the larger prawns, claws are often bound with elastic bands.

Live shrimp can also be packed in pre-chilled sawdust or wood shavings. These materials do not have good insulating properties so it is generally advisable to use an additional insulator. Some studies indicate that Japanese cedar is a preferred packing material because it seems to have some anti-bacteriological quantities. Other researchers believe that this material effectively absorbs metabolic waste products. In all cases, sawdust should be free of resins, pesticides and other chemical treatments. Live shrimp should be packed so that they are suspended in the medium but not compressed or able to move about. Movement can cause physical damage to the product. Enough

water should be sprayed into the shavings to make them moist but not excessively wet. The box should be filled to the top so that it is impossible for the live shrimp to crawl out of the shavings and become dehydrated. In a humid, low temperature environment, ammonia, produced as a metabolic waste, begins to accumulate and can become toxic. Generally, this problem is not as severe when shrimp are shipped in water.

Some packers substitute algae for sawdust. This provides the added advantage of creating a high humidity environment but care must be taken to ensure that the algae does not begin to decay and release noxious gases.

Other species of shrimp such as black tiger shrimp (*Penaeus monodon*) and freshwater prawns (*Macrobrachium rosenbergii*) cannot tolerate low temperatures. These species are often packed in oxygenated water in plastic bags.

Some researchers have noted increased survival rates when live shrimp were packed in a water and pure oxygen system. This oxygen environment also seemed to buffer the live shrimp against the effects of temperature fluctuation.

## **5. LIVE LOBSTERS**

Stress and physical damage are the major factors influencing live lobster quality during transport. Live lobster shipment stress factors include: temperature shifts such as inadequate cooling in warm climates and insufficient warmth in cold climates; low humidity; low oxygen; overcrowding, and; rough handling. Lobsters are solitary animals and are easily stressed when placed in communal settings. At different times of the year, live lobsters may have soft shells and increased blood protein levels. These seasonal shifts should be considered when developing a shipping protocol. Packaging coolants such as wet ice or gel packs that come in direct contact with live lobsters can cause stress and mortality.

To reduce the production of nitrogenous waste materials during transport, live lobsters should be held without feeding for several days prior to shipment. Recirculating seawater systems allow the live lobsters to purge. However, care must be taken not to hold lobster too long. Eventually when held without feeding, the live lobster will begin to digest its muscle tissue and build up of wastes will increase. There have been some experiments with materials that can absorb ammonia or can split the molecule into nontoxic substances. These processes are still experimental.

To avoid cannibalism and physical damage, live lobster (*Homarus americanus*) claws must be either pegged or banded shut. Most shippers use bands since these cause less physical damage to the product. Only good quality products should be shipped. Generally a minimum of a 24-hour waiting period prior to shipment should be used to allow lobsters to purge and to identify any weak individuals.

Prior to shipping, the body temperature of live lobsters should be lowered. Pre-chilling should be achieved slowly through a gradual reduction in body temperature. The ideal temperature is dependent upon the species and the ambient temperature of the harvest area. Cold water species can be chilled to 4° Centigrade and shipped at temperatures ranging from 1-7° Centigrade. Tropical species may be rendered dormant at temperatures as high as 14° Centigrade.

Live lobsters can be kept alive, out of water, in a high humidity environment for approximately 24 hours. Once the transport time increases beyond that, mortality increases significantly.

Live lobsters can be shipped in fiberboard boxes lined with expanded polystyrene. An absorbent pad should be placed in the bottom of the box. The live lobsters can be cushioned with moist newspapers. Live lobsters should be packed in layers separated by moist newspaper. Some shippers use seaweed, however, some algal species produce noxious gases as they break down and can harm the lobsters. Under the best shipping conditions, the humidity within the packing box should be approximately 70%.

Because live lobsters are high value products, care must be taken to avoid physical damage during shipping. New packing systems that allow lobsters to be packed vertically in individual compartments are available. The “Cloud Pack” system has been approved by IATA and many major air cargo carriers. This pack consists of a bottom section which holds the live lobster body and tail, a center section which holds the claws and a cover that contains gel ice and a moisture medium. The tail is folded under and the live lobster is placed in a compartment with the head and claws above the body. This packaging is expensive but can be reused and mortality is reduced. However, the shipping volume is increased and requires bulk shipping. Shippers who use ULDs may find that shipping costs become prohibitive because of the volume of the packaging.

## **6. LIVE ABALONE**

Live abalone are well suited for shipping because of their ability to attach to a substrate and survive out of seawater. Although chilling can decrease the metabolic rate, super chilling can kill abalone. Careful chilling will reduce the production of carbon dioxide and waste products during transport time.

Live abalone are usually not fed for two to four days prior to shipment. This reduces waste production during transit. Live abalone are generally shipped in plastic bags filled with pure oxygen with a thin sponge moistened with seawater. Live abalone survive best in a moist environment. If covered with water, they can actually suffocate during shipment. The sponge will also absorb moisture that is produced by the abalone during shipping. Place the live abalone on a waxed fiberboard or a plastic substrate. Once they take hold of the substrate they can be placed in the plastic bag. Some companies pack with a moist piece of clean burlap over the top of the abalone. Larger abalone generally require more oxygen than smaller specimens.

With transit times of less than six hours, live abalone can survive without an oxygen infusion. With proper packaging and oxygen infusion, live abalone can survive transit times up to 36 hours.

## **7. LIVE GREEN SEA URCHINS**

Live green sea urchins are relatively easy to ship while other species are much more delicate. Some shippers recommend pre-chilling the urchins and the packaging material. Live green sea urchins are simply placed into an insulated container that has been lined with a polyethylene bag. Gel packs are added as a coolant to retain a low temperature and the bag is sealed.

## **8. LIVE OYSTERS**

If handled carefully, live oysters can survive out of water for a week. Prior to shipment, fouling materials should be removed from the live oysters. Live oysters grown in suspended culture systems tend to have thinner shells than those grown on bottom, so extra care in packaging is advised. The area of harvest should always be considered when developing a shipping protocol.

Sometimes, live oysters harvested from submerged beds sometimes must be “hardened” prior to shipping. Since these live oysters have not been exposed to the periodic dry conditions in the intertidal zone, they will sometimes gape when exposed to air. This holding process (hardening) sometimes takes as much as three weeks. Gaping reduces the shelf life, quality of the product, and customer satisfaction. If the live oysters are cleaned and placed in mesh bags in the intertidal zone where they are acclimated to periods of dryness for several weeks, repeated exposure to air will strengthen the adductor muscle that closes the shell. This can reduce the amount of gaping and can strengthen the product to undergo shipping.

Live oysters from colder waters should be tested for Paralytic Shellfish Poisoning (PSP) as well as any additional tests that may be required by the importing country.

Generally 50 pound boxes are preferred for shipping live oysters in order to avoid damaged shells. A padding material, possibly newspapers can be used in the bottom of the box. A plastic liner is added. Live oysters are then placed in the box in layers with the cup side down. This helps to retain the liquid. Live oysters are layered in this manner to about 2 inches from the top of the box. Additional padding is placed around the top and sides of the live oysters. The plastic liner is then folded over the top of the live oysters and a coolant (gel packs) is placed on top. As usual, gel packs should not come into direct contact with the product since the shells may rupture the gel pack or the product can become over-chilled. For added protection, the gel packs can be wrapped in newspaper.

The box should not be completely sealed since live oysters circulation. Markings on the packing box should indicate that product and should have up arrows.

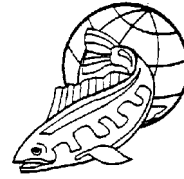

require air  
it contains live

In the United States, the size and format of the packing box specified by the rules of the Interstate Shellfish Sanitation Most importing countries require that oysters and other shellfish be managed under an equivalent program.

labels are  
P r o g r a m .  
m o l l u s c a n

## 9. LIVE MUSSELS

Farmed mussels have thin shells and, like oysters, should be handled with care. Live mussels must be kept moist and cold at all times. The byssus threads which attach the mussel to the substrate should not be pulled out since this will kill the mussel. Some processors cut the byssus threads. Immediately upon harvest the mussels should be chilled using wet ice. All melt water should drain away from the product.

Generally the inside of the box is lined with a polyethylene sheet or bag. Ice bags or frozen gel packs are packed around the product. To maintain a humid environment, moist rags or seaweed can be used. Temperature should be maintained between 2-4° Centigrade.

## 10. LIVE CRABS

Live crabs should be held for 24 hours prior to shipping. During this period their body temperature should be slowly lowered. High stocking densities and warm temperatures often result in cannibalism. For many species, live crabs are tied with raffia. This reduces cannibalism and movement during shipment.

During shipment, control of temperature and humidity is critical. Most live crabs survive best in an environment of approximately 70% relative humidity. Low temperatures can be achieved by the use of a coolant (gel packs) placed in bottom of the packing box. Moisture absorbent pads can be placed around the gel packs. Live crabs can be packed in layers separated by moistened material such as wood shavings, newspapers or burlap. A layer of moistened materials can be placed on top. The box should have ventilation holes on the top edge. Crabs should not be packed as high as the ventilation holes.

### **SECTION THREE:**

# CHINESE TAIPEI

Chinese Taipei imports nearly all of its energy needs along with most of the raw materials needed to maintain industrial production and a diversity of manufactured and agricultural goods. The phased reduction of tariffs and non-tariff barriers on industrial and agricultural products following Chinese Taipei accession to the World Trade Organization (WTO) should raise its annual import growth rate to 8-9 percent throughout the rest of the decade. Chinese Taipei outbound foreign exchange restrictions have been liberalized.

Chinese Taipei has made considerable progress in improving market access for foreign goods and services by lowering tariff and non-tariff barriers and easing investment approval procedures. Although import duties were lowered (the average tariff is 9 percent on industrial products), the tariff for fish and seafood products range from 20-50 percent.

Generally, Chinese Taipei consumers show a strong preference for live and fresh fish and seafood. But consumers (young adults and double income families) are beginning to purchase more frozen products out of convenience.

## I. GENERAL SHIPPING PROCEDURES

(Be advised that shipping regulations change on a regular basis)

■ <b>Language</b>	Mandarin Chinese (official language), English												
■ <b>Weights and Measures</b>	Metric												
■ <b>Currency</b>	NEW Taiwan Dollar (NT\$)												
■ <b>International Dialing Code</b>	886												
■ <b>Public Holidays</b>	The following are the official civic and religious holidays, when banks, offices and most shops are closed. Most holidays fall on a fixed date every year, but some traditional holidays change according to the Chinese lunar calendar from year to year:  <table><tr><td>Founding Day</td><td>January 1-3</td></tr><tr><td>*Chinese New Year</td><td>January - February</td></tr><tr><td>Youth Day</td><td>March 29</td></tr><tr><td>Tomb Sweeping Day</td><td>April 5</td></tr><tr><td>*Dragon Boat Festival</td><td>June</td></tr><tr><td>*Mid-Autumn Festival</td><td>September</td></tr></table>	Founding Day	January 1-3	*Chinese New Year	January - February	Youth Day	March 29	Tomb Sweeping Day	April 5	*Dragon Boat Festival	June	*Mid-Autumn Festival	September
Founding Day	January 1-3												
*Chinese New Year	January - February												
Youth Day	March 29												
Tomb Sweeping Day	April 5												
*Dragon Boat Festival	June												
*Mid-Autumn Festival	September												

Teacher's Day	September 28
National Day	October 10
Taiwan Retrocession Day	October 25
Chiang Kai-shek's Birthday	October 31
Sun Yat-sen's Birthday	November 12
Constitution Day	December 25

\* According to the Chinese lunar calendar

## ■ Documents for Commercial Shipments

(Please refer to the "Preparing the Shipment" chapter and glossary for further explanation of terms)

Documents required for commercial shipments to, or from Chinese Taipei include the commercial invoice, bill of lading or air waybill, packing list, and certificate of origin. Most shipments of live and fresh fish and seafood products to Chinese Taipei do not require certificates of inspection or quarantine issued in the country of origin but are subject to inspection and quarantine upon importation into Chinese Taipei. The major exceptions are live or chilled salmonids, perches, catfish and cyprinids which do require health certificates. Health certificates can be helpful in speeding the passage of other products through Customs.

No requirements exist as to the form of a commercial invoice or bill of lading. Customs does not permit the grouping of marks or numbers on a shipment of mixed commodities.

### 1 Commercial Invoice.

Commercial Invoices ( Four copies should be prepared).

Included in the Commercial Invoice:

- a) Date of issue of the invoice.
- b) Name and address of the supplier.
- c) Name and address of the importer.
- d) Number of cases.
- e) Gross weight and measurements.
- f) Full description of goods.
- g) Total product value for Customs.
- h) Import License Number.
- i) Discounts or commissions if any.

All invoices must be signed and certified as true and correct by the supplier (original signatures required on each copy).

NOTE: The commodity description and value on the commercial invoice must agree with those on the import license.

2. Certificate of Origin.  
Required on some products.
3. Delivery Order.
4. Packing List.
5. Suppliers certificate.
6. Price declaration form.

#### ■ Sample Shipments

Sample shipments require one original commercial invoice and four (4) copies. Samples also require an import license.

#### ■ Payment Methods

Bank-to-bank Letters of Credit (L/C) constitute Chinese Taipei's most important import payment process. On a lesser scale, company to company payments are made via Open Account (O/A), Documents Against Payment (D/P) and Documents Against Acceptance (D/A). Exporters can minimize financial risk by requiring Chinese Taipei trading partners to finance their imports through L/Cs. A large majority of Chinese Taipei's importers utilize usance L/Cs with validity of up to 180 days.

#### ■ Import License

Chinese Taipei continues to maintain an import licensing system. A foreign supplier's pro-forma invoice (quotation) is required for application of an import permit.

Companies in Chinese Taipei must be registered with the Board of Foreign Trade (BOFT) before they are permitted to engage in foreign trade.

The import licensing system is imposed on some sensitive products such as squid and several other fishery products.

#### ■ Customs Clearance

Customs clearance should be arranged through the importer, a Customs broker or through the seller's representative.



Refrigerated and frozen storage is available at the Air Cargo Terminal at Chiang Kai-shek Airport

Restricted items include: Fish and live animals

#### ■ **Packaging**

There are no known legal requirements stipulating specific packaging materials or sizes to be used for fish and seafood.

#### ■ **Labeling, Marking Requirements**

Import requirements and enforcement for food products entering Chinese Taipei are frequently modified. It is recommended that exporters contact the Chinese Taipei importer directly to ensure that product specifications and labeling meet current regulations.

For **retail packaged** fresh fish and seafood imported into Chinese Taipei the following applies:

Chinese Taipei labeling regulations require that the net contents of packaged goods will be shown in metric units. Dual labeling in metric and non-metric units is permitted. Measurements calibrated in non-metric units must show metric equivalents.

In 1995 Chinese Taipei tightened regulations on Chinese labeling for food items, expanding coverage to all food products sold at retail (but allowing exemptions for some food service items) and requiring the labels to be affixed prior to customs clearance. Required information includes name and address of manufacturer or importer, date of production and/or expiration date and list of ingredients.

Chinese Taipei's Consumer Protection Law requires that all imported goods have Chinese language labels and instructions which will be at least as comprehensive as the language-of-origin labels and accompanying instructions.

Revisions to Chinese Taipei's "Law Governing Food Sanitation" went into effect in March 1995. The Chinese Taipei authorities are strictly enforcing the food and beverage labeling requirements. Improper or altered labels risk rejection by customs food inspectors at the port of entry. If this occurs, it is difficult, if not impossible, to retrieve product or return goods to the country of origin.

All food products imported into Chinese Taipei must indicate the following information in Chinese on the label:

- ! Product name.
- ! Weight, volume or quantity of the contents (if a mixture of two or more components they must be listed separately).
- ! Name of food additives.
- ! Name and detailed address of the manufacturer.
- ! Name and detailed address of the importer.
- ! Date of manufacture (year, month, date) must be printed in that order.

To distinguish the month from the date, the Chinese character for “month” and “date” must be included on the label. An expiration date may be used in lieu of the date of manufacture. Coded formats are not allowed.

The following types of businesses may apply for an exemption from the Chinese labeling requirement:

- a. Food processing plants which import food for processing.
- b. Restaurants, fast food stores and bakeries, which import food for their own kitchen.
- c. Importers who import food for processing, for re-pack or change-pack, not for distribution.

It is important that exporters contact the importer directly to ensure that product specifications and labeling meet current Chinese Taipei regulations

## ■ Export Documentation

### Certificate of Origin

Required for some products and can be useful for others.

To apply for a Certificate of Origin, the exporter must complete an application form and submit it to the Bureau of Commodity Inspection and Quarantine (BCIQ) along with the following documents:

1. Documents certifying that the commodities have been examined and released by the Customs office for shipment.
2. A document stating the origin of the raw materials, a certificate of processing or related document.
3. A copy of the Bill of Lading or air waybill.

4. A copy of the sales invoice issued by the exporter.
5. (For export processed products whose raw materials are imported from abroad) customs import certificate, import license or a copy of a sales invoice issued by the foreign manufacturer or trader.

With documents stating that the commodity and Certificate of Origin must be delivered to a consignee at the same time, an exporter may apply for earlier issuance of Certificate of Origin prior to the customs examination and release for shipment. However, certificates of the Customs examinations and release should be submitted to BCIQ within 45 days after the shipment to conclude the case. Otherwise, such an advantage of issuing the certificate earlier will be withheld.

## **II. TARIFFS**

There appear to be no systemic problems in Customs regulations for exporters to Chinese Taipei. In the past five years, Chinese Taipei has made significant progress in reducing tariffs. Although Chinese Taipei is not a member of the World Trade Organization (WTO), it is negotiating to join. Chinese Taipei has also agreed to abide by the WTO Customs valuation code.

Chinese Taipei has an import duty on fish and seafood products that averages between 20-50 percent on a C.I.F. basis, ad valorem. In addition to the import duty, importers must also pay a 0.5 percent harbor construction fee and a 5 percent value-added tax (VAT). Goods entering Chinese Taipei by air freight or parcel post are exempt from harbor fees. A commodity tax must be paid if an imported product falls into one of eight commodity categories. Fish and seafood products do not fall into any of the categories, therefore, no commodity tax is levied on fish and seafood products.

Importers must pay a Customs clearance fee on each shipment of approximately \$400 USD.

The dutiable value of an import into Chinese Taipei is defined as its CIF value. If Customs officials consider an invoice's transactions value to be too low, they will value the item based on the actual transaction value. Chinese Taipei uses non-tariff barriers selectively.

Chinese Taipei's Executive Yuan promulgated "Regulations Governing Revenue, Expenditure, Custody and Disbursement of Fish Product Balance Fund" in April 1994. Under the regulations, whenever prices of mackerel, sardine, squid, saury, oceanic shrimps (excluding lobsters), hair-tail fish, gurnard, milkfish and such officially promulgated species come down in a row, the Chinese Taipei government provides subsidies with the balance fund, thus protecting the commercial fishing industry.

### **III. INSPECTION**

#### **■ Standards**

“Chinese National Standards (CNS),” written and published by the National Bureau of Standards of the Ministry of Economic Affairs, lists relevant standards requirements for imported products into Chinese Taipei. CNS are similar in conformity with international standards such as ISO.

#### **■ Commodity Inspection**

The Bureau of Commodity Inspection and Quarantine (BCIQ) carries out necessary commodity inspection measures according to Commodity Inspection Law. The purpose of this inspection is to promote the quality of commodities, ensure product safety, and protect consumer interests. The methods of commodity inspections generally conform to international standards.

#### **■ Food Additives**

With regard to food products, Chinese Taipei authorities maintain a restrictive list of food additives and colorings and allowable tolerances for chemical residues on fresh food products. Imported products can only contain approved ingredients. Substitutes are not allowed entry.

### **IV. CHINESE TAIPEI’S CONSUMER PROTECTION LAW**

On January 11, 1994, Chinese Taipei passed a new Consumer Protection Law (CPL). The law has implications for all importers of fish and seafood products into Chinese Taipei. Many importers have expressed concern about this law due to its vague wording and broad liability provisions. The following is a summary:

The CPL calls for goods to be “free from any danger to safety or sanitation”.

The CPL provides for very broad liability by including every “business operator” in the marketing chain for possible punitive damages arising from cases of consumer injury.

The CPL allows third parties (for example, consumer groups, family members) to sue on behalf of an injured party.

The CPL requires business operators “to properly handle the complaint made by the consumers within 15 days of such complaint”.

Provisions for caps on court fees and punitive damage awards could encourage frivolous lawsuits.

Consumer protection groups are given broad new powers under the law. Concern has been raised that such consumer groups may initiate unfounded suits on behalf of consumers.

Local authorities have broad powers under the CPL and most of the enforcement responsibility, as well as responsibility for conducting investigations and product testing.

The CPL does not make clear the relationship between the consumer protection law and negligence provisions under Chinese Taipei's civil law.

The CPL requires that all imported goods be "accompanied with labels and instructions in Chinese, the contents of which will not be less comprehensive than the contents of labels or pamphlets from the place of origin".

## **V. SPECIFIC REGULATIONS FOR FISH AND SEAFOOD**

With the exception of live or chilled salmonids, perches, catfish and cyprinids, no health documents are required to import fish and seafood to Chinese Taipei.

Although it is not mandatory, a certificate of country of origin and an export health certificate can be helpful for import. All seafood imports are subject to inspection upon entry by Chinese Taipei's Bureau of Commodity Inspection and Quarantine (BCIQ).

### **■ Importation from Cholera-infected Areas**

Chinese Taipei *prohibits* the importation of fish and seafood from cholera-infected areas. Before Customs processing can begin, any shipment which *has passed through* cholera-infected areas must be held by the quarantine authority until it is confirmed that it is not contaminated by toxigenic *Vibrio cholerae*.

Fish and seafood products in enclosed containers passing through cholera-infected areas should be properly sealed with metallic or plastic straps showing a control code prior to leaving the port of embarkation.

In order to apply for quarantine inspection, the bill of lading issued at the exporting company must include the control codes shown on the straps, containers' assigned numbers and total number of containers shipped.

If the product does not have the appropriate seals and paperwork, it is subject to a 36-48 hour quarantine period during which time it will be tested for the presence of *Vibrio cholerae*. The Cholera Testing Fee is NT \$ 2000.

■ **Salmonid, perch, catfish and cyprinids health certificate**

A health certificate, issued by the animal quarantine authorities of the exporting country, is required for the import of live/chilled salmonids, perch, catfish and cyprinids. The health certificate should include the following items:

1) Origin of the products, including:

- S Name of the exporting country.
- S Name of the animal quarantine authority.
- S The state or province from which the product originates.

2) A statement regarding the status of the following diseases in fish in the exporting country:

a) Salmonids:

- S Viral hemorrhagic septicemia (viral hemorrhagic septicemia virus).
- S Infectious hematopoietic necrosis (Infectious hematopoietic necrosis virus).
- S Salmonid herpes virus infection (Salmonid herpes virus type 2).
- S Infectious pancreatic necrosis (Infectious pancreatic necrosis virus).
- S Bacterial kidney disease (*Renibacterium salmoninarum*).

b) Perches:

- S Epizootic hematopoietic necrosis (Epizootic hematopoietic necrosis virus).

c) Catfishes:

- S Catfish herpes virus infection (Ictalurid herpes virus type 1).
- S Catfish edwardsiellosis (*Edwardsiella ictalurica*)

d) Cyprinids:

- S Spring viremia of carp (Spring viremia of carp virus).

- 3) Declaration document must state:
  - a) The exporting country is free from the diseases listed above in part 2. Or,
  - b) The exporting country is not free from one or several of the diseases listed, and the fish of the present consignment have been eviscerated.
- 4) All appropriate boxes or containers shall be marked with all the items specified in part 1, above.

#### ■ Quarantine/Health Contact

##### **Bureau of Commodity Inspection & Quarantine (BCIQ)**

Dr Chou Ting-Kuang, Director  
Department of Animal and Plant Quarantine  
Bureau of Commodity Inspection & Quarantine  
4 Chinan Road, Section 1  
Chinese Taipei  
Tel: (886) (2) 343-1816  
Fax: (886) (2) 393-2324

#### **VI. BONDED FACTORIES AND WAREHOUSES**

Bonded factories may be established anywhere in Chinese Taipei. They are not restricted to designated industrial or export processing zones. Bonded factory companies produce primarily for export markets and may import their manufacturing components, raw materials, and production equipment duty free. They may sell a designated percentage of their production on the Chinese Taipei market.

Bonded storage facilities are available in Chinese Taipei and are limited almost entirely to those warehouses under the direct supervision of the Directorate General of Customs. Goods may be entered into bonded warehouses on arrival in Chinese Taipei, provided the consignee has made prior application to Customs for such entry.

#### **VII. CHINESE TAIPEI FREE TRADE ZONES**

Chinese Taipei does not have any duty free foreign trade zones or free ports. However, Chinese Taipei has established three export processing zones (EPZs) in order to encourage investment, and to expand the export of services and products. Therefore, all products imported by enterprises located in EPZs for their own use are exempt from Customs duties. However, the authorities will

not extend duty-free treatment to items whose duty rate is already considered minimal, materials known to pollute the environment, and items for which a domestic source is readily available.

### **VIII. CHINESE TAIPEI'S FISH AND SEAFOOD DISTRIBUTION SYSTEM**

Several methods are utilized to distribute imported fish and seafood to the retail sector. Although the majority of fish and seafood are currently sold through wholesale markets, such markets have seen a significant decrease in both volume and value of products traded as more importers establish direct linkages with wholesalers and retailers.

The vast majority of imported fish and seafood are sold to wholesalers who in turn sell directly to restaurants, hotels and retail outlets. Very little imported fish and seafood are handled by distributors.

Estimates place 65% of all imported fish and seafood being sold in wet markets and 30% sold in supermarkets/hypermarkets. The remainder (5%) is sold to restaurants by importers. Some large restaurants and outdoor banquet operators purchase products from wholesale markets or wet markets.

### **Additional Chinese Taipei Contacts:**

The Taiwan Fisheries Bureau (TFB), the Fourth Division of the TFB takes charge of transportation and marketing, preservation of fresh fisheries products, development of sanitary conditions in the market, promotion of sales and assistance in fish markets.



To safeguard the consumer's health the TFB has set up sanitation examination centers at 19 of Chinese Taipei's leading fish markets. Fish and seafood products are sample checked.

Overseas Fisheries Development Council of the Republic of China  
19, Lane 113, Roosevelt Road Sec 4  
Chinese Taipei  
Tel: (886) 2-738-5486  
Fax: (886) 2-738-4329

Bureau of Commodity Inspection & Quarantine (BCIQ)  
4, Chinan Road, Sec 1,  
Chinese Taipei  
Tel (886) 2- 343-1700  
Fax: (886) 2- 393-2324

Fish Breeding Association of the Republic of China  
14-8F, Hao Sen Road,  
PingTung, Chinese Taipei  
Tel: (886) 8-7230700  
Fax: (886) 8-7230699

China External Trade Development Council (CETRA)  
4-8th Fl., 333, Keelung Road, Sec 1  
Chinese Taipei  
Fax: 886-2-757-6633

**HONG KONG**

**(Hong Kong Special Administrative Region of the People's Republic of China)**

The Hong Kong Special Administrative Region of the People's Republic Of China (HKSAR) is a free port and does not levy any Customs tariffs or duties on imports. Hong Kong maintains no anti-dumping laws, countervailing duty laws, import quotas or tariffs. There are no value-added or general services taxes. It is a major trading center with a large number of agents and distributors. Hong Kong essentially serves as a gateway to mainland China with its enormous consumer population.

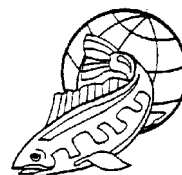

## **I. GENERAL SHIPPING PROCEDURES**

(Be advised that shipping regulations change on a regular basis)

- **Language** Chinese (Cantonese, National) , English (National)  
Note: Language on documents should be in English
  
- **Weights and Measures** Metric
  
- **Currency** Hong Kong Dollar (HK\$)
  
- **International Dialing Code** 852
  
- **Public Holidays**

The following are the official holidays when banks, offices and many shops are closed. Most holidays fall on a fixed date every year, but some traditional holidays change according to the Chinese lunar year:

New Year's Day	January 1
Chinese New Year	January - February
Ching Ming Festival	April 4
Easter	March - April (3 days)
Tuen Ng (Dragon Boat Festival)	June 20
August Saturday	August (third week)
Liberation Day	August 26
Mid-Autumn Festival	September - October
Chung Yeung Festival	October 21
Christmas	December 25 - 26

## ■ Commercial Shipments

(Please refer to the “Preparing the Shipment chapter and glossary for further explanation of terms)

Hong Kong adheres to the Standards Code negotiated under the General Agreement on Tariffs and Trade (GATT). Any food, whether imported or locally produced, intended for sale in Hong Kong must comply with the local food laws.

### 1 Commercial Invoice.

No special form of invoice is required but two copies should be supplied. The following details should be included on the invoice:

- a) Number of packages.
- b) Marks, prices and descriptions of goods.
- c) Quantity.
- d) Place of origin.
- e) Insurance and freight.
- f) Additional information to facilitate Customs clearance.
- g) CIF and FOB value.

## ■ Certificate of Origin

Not generally required. However, may be required in certain circumstances. Check with the buyer.

## ■ Marking

There are no special marks particular to Hong Kong. It is not essential to have shipping instructions marked on cases in Chinese characters.

## ■ Labeling

Non-tariff barriers such as labeling requirements, standards, etcetera. are virtually nonexistent. However, labeling should be designed in a manner not to mislead the consumer. Labeling can be in either English or Chinese.

For retail sales, a use by date (day/month/year) is required in Chinese characters, the name and address of the processor, the net weight and the storage conditions. Labeling can be in either English or Chinese. Irradiated products must be labeled in both Chinese and English.

## ■ Sample Shipments

Samples or advertising/promotion materials of no commercial value and which are not for resale are exempt from duty and require only a Pro Forma Invoice. Samples with commercial value can be imported under an ATA Carnet available through local Chambers of Commerce.

## ■ Transshipment of Product

Documentation required for transshipping goods:

- 1) Transit permit.

2) Health certificate when applicable.

## **II. TARIFFS**

The Hong Kong Special Administrative Region of the People's Republic of China (HKSAR of the PRC) is a free port and does not levy any Customs tariff on imports. There is no tariff quota or surcharge. There are no value added or general services taxes. Excise duties are levied on only four types of goods irrespective of whether they are imported or locally manufactured. Live and fresh fish and seafood are not taxed.

Traders are required by law to use the Harmonized System to make trade declarations. The Hong Kong Imports and Exports Classification List (Harmonized System) is published by the HKSAR Government and is available at the sales office of the Hong Kong Customs Census and Statistics Department and the HKSAR Government Publications Centre.

## **III. IMPORT/EXPORT DECLARATIONS**

Under the Import and Export (Registration) Regulations, Chapter 60 of the Laws of Hong Kong, every person who imports or exports any article other than an exempted article is required to lodge with the Commissioner of Customs and Excise an accurate and complete import/export declaration and to pay the necessary declaration charges within 14 days after the importation/exportation of the article. The import/export declarations lodged by importers and exporters are primarily used for compiling trade statistics by the Census and Statistics Department.

On receipt of the import/export declarations, the Customs and Excise Department transfers them to the Census and Statistics Department for checking and compliance of trade statistics based on information contained therein. To enable work to proceed effectively, the Commissioner of Customs and Excise has authorized specific officers of the Census and Statistics Department to enforce the regulations relating to import/export declarations.

### **■ Exempted Articles**

Exempted Articles (that apply to fish and seafood products) as stipulated in regulation 3 of the Import and Export (Registration) Regulations:

- Transshipment cargo.
- Transit cargo.
- Articles imported or exported by the Government or the armed forces.
- Any article:

i. which consists solely of, and, is marked clearly as, a sample of any product and which is intended, to the satisfaction of the Commissioner, to be distributed free of charge for the purpose of advertising the article of which it is a sample.

ii. valued at less than HK \$1,000, which consists solely of a sample of any product and is intended, to the satisfaction of the Commissioner, to be used for the purpose of advertising the article of which it is a sample.

iii. which is imported solely for the purpose of exhibition and which is intended, to the satisfaction of the Commissioner, to be exported after it has been exhibited and is neither sold nor disposed of in any other way in Hong Kong.

iv. which is exported solely for the purpose of exhibition and which is intended, to the satisfaction of the Commissioner to be imported after the exhibition.

v. which is imported after having been exported for exhibition in accordance with subparagraph (iv).

vi. which is imported or exported under and in accordance with an ATA Carnet.

- Marine fish, including edible crustaceans, molluscs and other similar edible products derived from the sea, arriving in Hong Kong direct from fishing grounds on fishing craft registered or licensed in Hong Kong.

Hong Kong uses the Harmonized Commodity Description and Coding System (HS). Since there are no duties nor tariffs on most products, the system is used to assist in making international comparisons.

■ **Methods for Lodgement of Import/Export Declarations** <[www.info.gov.hk/censtatd](http://www.info.gov.hk/censtatd)>

Import and export declarations should be submitted on appropriate forms (*Import Declaration Form 1A (for imports of food items only)*; *Export/Re-export Declaration Form 2*) or on diskette in specified format. Import declarations can be submitted electronically through the Electronic Data Interchange-Trade Declaration System (EDI-TDEC System).

Import /export declarations can be lodged in person at the following offices with payment of imports and exports declaration charge by cash or crossed check made payable to “The Government of the Hong Kong Special Administrative Region”:

- a) Customs and Excise Department Collection Office (Kowloon)  
G/F, Middle Road Multi-Story Carpark Building  
Tsimshatsui  
Kowloon  
Tel: (852) 2311 3035

- b) Customs and Excise Department Collections Office (Hong Kong)  
2/F, Harbour Building  
38 Pier Road, Central  
Hong Kong  
Tel: (852) 2852 3048

Office hours of the collection offices are as follows:  
Monday - Friday 09:00 - 16:30  
Saturday - 09:00 - 12:00

Further inquiries on procedures can be addressed to the Trade Statistics Branch of the Census and Statistics Department at Wanchai Tower, 12 Harbour Road, Wanchai, Hong Kong, Telephone (852) 2877 1818, Fax: (852) 2824 2782.

## **IV. TEMPORARY IMPORTS**

### **■ Temporary Import of Goods under ATA Carnets**

HKSAR accepts the ATA Carnets issued by the authorized issuing associations of countries which are contracting parties to Customs Convention on the ATA Carnets for Temporary Admission of Goods or, the Convention on Temporary Admission (Istanbul Convention).

Goods imported into HKSAR under ATA Carnets are granted temporary admission into the territory without payment of duty and without having to lodge and import or export declaration to the Commissioner of Customs and Excise. Payment of imports and exports declaration charge are exempted.

The ATA Carnets however, do not exempt other statutory requirements such as import licenses or quota visa. Persons importing goods under ATA Carnets are advised to obtain the required documents from the relevant authorities prior to importation.

In HKSAR, the authorized issuing association of ATA Carnets is the Hong Kong General Chamber of Commerce (HKGCC). Its office is located at 23/F, Sivercorp International Tower, 707-713 Nathan Road, Mongkok, Kowloon, Hong Kong. Tel: 852 2395 5515; Fax: 852 2398 3309.

A fee is charged for each issue of the ATA Carnet at HK\$ 859 for members of the HKGCC and HK\$ 1,700 for nonmembers. In addition an amount equal to the duty payable on the goods at the country of import will be collected as guarantee for due compliance of the terms and conditions of the Carnet.

### **■ Temporary Import of Prohibited Goods**

In general, prohibited goods are exempted from obtaining import licenses if they are passing through HKSAR without leaving the importing conveyance. This would include endangered species of fish and seafood. Contact the Agriculture and Fisheries Department at 6/F, Canton Road Government Offices, 393 Canton Road, Kowloon, Hong Kong, Tel: 852 2733 2282; Fax: 852 2766 3749 for more information.

## **V. CUSTOMS INSPECTION** < [www.info.gov.hk/customs](http://www.info.gov.hk/customs)>

The Customs and Excise Department control on imported goods is done through inspection of documents such as manifests, and where necessary, physical examination of the goods. Physical examination is conducted on a selective basis. Selected consignments are detained for physical examination by Customs Officers.

Hong Kong is in the process of linking the Department of Health, air cargo companies and Customs to help speed the clearance process.

### **■ Customs Clearance**

If a consignment of goods is elected by Customs for examination, the importer or representative can approach the air cargo carrier or freight forwarder concerned for advice on Customs clearance procedures. Or, direct inquiries can be made with the Customs Headquarters which will then provide contact information on the Customs Office at the airport.

Contact:  
Customs & Excise Department Headquarters  
9/F, Harbour Building  
38 Pier Road  
Central, Hong Kong  
Customs Duty Controller  
Tel: 852 2852 3185  
Fax: 852 2542 3334

Required documentation for Customs clearance of commercial consignments includes:

- Air waybill or bill of lading.
- Manifest, commercial invoice, packing list, shipper's catalogue.
- Other documents, such as the import license, removal permit, etcetera.  
(Dependent on the final disposition of the cargo).

Customs clearance is available at the airport through the consignee, and is available 24 hours a day. There are no restrictions regarding the clearance of consignments and no charges exist.

### ■ Import Declaration

In general, any person who imports any goods into Hong Kong is required to lodge with the Customs and Excise Department an import declaration within 14 days after the importation of the goods. Export declaration is required for exports.

The declaration must be in the prescribed form or microcomputer diskette in specified format. Declaration forms are available for sale at the following offices:

- Customs and Excise Department Collection Office (Hong Kong)  
2/F, Harbour Building, 38 Pier Road, Central, Hong Kong
- Customs and Excise Department Collection office (Kowloon)  
G/F, Middle Road, Multi-Story Carpark Building,  
Tsimshatsui, Kowloon
- Government Publications Sales Centre  
G/F, Queensway Government Offices, Low Block,  
66 Queensway, Hong Kong

Import declarations should be lodged at the above Collection Offices with payment of the imports and exports declaration charge. For food items, a flat rate of HK \$5 per declaration is charged irrespective of the value of the shipment. For exports, the rate is HK\$5 for the first HK\$10,000 of value and HK\$0.50 for each additional HK\$1,000.

Inquiries about the submission of import and export declarations can be addressed to the Trade Statistics Branch of the Census and Statistics Department at Wanchai Tower, 12 Harbour Road, Wan Chai, Hong Kong, Telephone (852) 2877 1818 Fax: (852) 2824 2782

### ■ Storage Charges

For imports, the first 48-hour period is free commencing at 02:00 hours on the day following the day of arrival. This free period does not include Sundays or public holidays. Subsequent 24-hour periods (including Sundays and public holidays) or part thereof are charged at HK\$ 1.70 per kg. There is a minimum charge per consignment of HK\$ 34.00. Import and export charges are available for valuable cargo shipments. Contact Hong Kong International Airport for details.

Cold storage facilities are available at Customs.

### ■ Customs Hours

For general cargo: Monday through Friday 08:00 - 15:00.

Saturday, Sunday and public holidays closed.

Clearance outside Customs hours is possible for live products and perishables.



## ■ Hong Kong Air Terminal

Hong Kong Air Cargo Terminals Limited (HACTL) has established the following customer service standards:

- Consignments to be available for collection, examination or transshipment 3 hours after arrival.
- Cleared consignments to be available within 15 minutes of consignee arriving at import collection points.
- Customers will not wait more than 30 minutes after arrival for allocation of truck dock.
- Cargo reception will be completed within 30 minutes after customer's arrival at truck docks.

## ■ Useful Customs Telephone Contacts

General Enquires

- 24- hour Enquiry Hotline Service Tel: (852) 2815 7711
- Duty Controller's Office Tel: (852) 2852 3185 Fax: (852) 2542 3334
- Duty Controller's Office (24 hours) Tel: (852) 2921 6610

Trade Declaration and Assessment

- Enquiry on Completing and Lodging Import/Export Declaration Tel: (852) 2852 3048 Fax: (852) 2739 6232
- Import/Export Declaration Verification and Assessment Tel: (852) 2398 5297 Fax: (852) 2398 1848

## VI. CITES/ENDANGERED SPECIES

*(List of CITES fish and seafood species can be found in the Appendix )*

The Hong Kong Government is a party to the Washington Convention on the Control of Trade of Endangered Species and exercises strict control over the shipment of live specimens of "Scheduled Species". "Endangered Species" include both live and dead endangered species and their parts and derivatives.

No CITES scheduled fish and seafood species will be accepted for shipment unless a valid export license has been obtained from the country of departure and a valid import license for the country of import, issued under CITES based local legislation.

To import or possess any endangered species, a CITES Import/Possession License must be obtained for individual shipments in advance (one month minimum) from the Agriculture and Fisheries Department. Applications, supported with valid documents such as export permit from the exporting country and invoice, should be made in specified form (AF 243 Rev. 3/97 for import or possession, AF 244 for export) and submitted to:

Import Control Section  
Agriculture and Fisheries Department at 6/F  
Canton Road Government Offices  
393 Canton Road  
Kowloon, Hong Kong  
Tel: (852) 2733 2282  
Tel: (852) 2733 2452 (24-hour Interactive Telephone Inquiry)  
Fax: (852) 2766 3749

CITES Re-Export Certificate  
Endangered Species Protection (Licensing) Section  
Room 640  
Agriculture and Fisheries Department  
393 Canton Road  
Kowloon, Hong Kong  
Tel: (852) 2733 2233  
Fax: (852) 2376 3749  
From Monday to Friday: 08:30 - 12:45 hrs; 13:45 - 16:30 hrs  
Saturday: 09:00 - 11:45 hrs

Specified forms are available from the Department of Agriculture and Fisheries. Forms can be downloaded from the Internet at: <<http://www.info.gov.hk/forms>>.

Documents to support the application to the Agriculture and Fisheries Department include:

- |             |  |
|-------------|--|
| For Import: | Photocopy of a valid CITES Export Permit from the CITES Management Authority of the exporting country.   |
| For Export: | Photocopy of the Import/Possession License issued by the Department of Agriculture and Fisheries or Export Permit/Certificate of Origin issued by the exporting country for certain specimens.<br>Documents (such as an invoice) showing the chain of transactions from the original importer, and subsequent traders to the exporter. |

For Possession:            Photocopy of the original Possession License issued by the Department of Agriculture and Fisheries to the traders (supplier).  
Documents (such as an invoice) showing the transaction from the supplier to the applicant.

Normally five working days are required for processing an application for licenses that cover parts and derivatives, and eight working days for live specimens. Applications may be delayed if information is incomplete or supporting documents are lacking. An appropriate fee will be charged for the issue of a license. Inspection of specimens by the Department of Agriculture and Fisheries may be required.

The issue of licenses is not automatic and import/export/delivery of the specimens should only be arranged after the relevant licenses have been granted.

## **VII. FISH AND SEAFOOD IMPORTS**

The importation of fish and seafood into Hong Kong is governed by the Food and Drugs section of the Public Health and Municipal Services Ordinance Cap. 132 and its subsidiary legislation which is enforced by the Hygiene Division of the Department of Health.

The legislation states: “Countries exporting food products, agricultural products or otherwise, to Hong Kong are expected to grow, harvest and process food according to the Code of Hygienic Practice recommended by the Codex Alimentarius Commission of the Food and Agriculture Organization of the United Nations, World Health Organization or other Good Manufacturing or Agricultural Practice of recognized standards as appropriate. To ensure the quality and wholesomeness of the food, competent authorities of the country of origin are requested to issue health certificates in respect of their products for export to Hong Kong.”

### **■ Health Certificates**

While not always requested by relevant Hong Kong authorities, it is prudent for fish and seafood imported into Hong Kong to be accompanied by a Health Certificate. The Health Certificate requested by Hong Kong’s governmental authorities should include the following information:

1. Health Certificate of Food in General:
  - (a) Health certification to be made by the competent authority in the country of origin.
  - (b) Health certification:
    - (i) The (name of imported food product) is processed and packed

under hygienic conditions.

- (ii) The (name of imported food product) does not contain any substance or substances in such amount as to be poisonous, harmful or injurious to health.
- (iii) The (name of imported food product) is fit for human consumption and is permitted to be sold as food for human consumption in (name of country of origin).

2. Health Certification for Marine Products:

- (a) The marine product is processed and packed under hygienic conditions.
- (b) The marine product does not contain any substances including biotoxins, contaminants like pesticides, trace metals, etc. in such amounts as to be poisonous, harmful or injurious to health.
- (c) The marine product is fit for human consumption and is permitted to be sold as food in the country of origin.

For marine products coming from cholera infected places, the following additional certification is also required:

- (i) The marine product is not collected from areas where any cholera case has been reported.
- (ii) The marine product has been found to be free from the infection of cholera vibrios.

For marine products to be consumed in the raw state (sushi and sashimi), an additional statement “fit for human consumption in the raw state” is required.

3. Health Certificate for Oysters to be Consumed in the Raw State:

- A) Health certification by the competent health authority of the country of origin including the following information:
  - (i) The oysters are collected or harvested from sanitary waters which have not been polluted; or the oysters have been cleansed by relaying in clean water for (state number) days or

the oysters have been cleansed in the approved shellfish purification plant at (address of plant).

- (ii) The oysters are packed under hygienic conditions.
- (iii) The oysters do not contain any substance which is poisonous, harmful or injurious to health.
- (iv) The oysters are fit for human consumption and are permitted to be sold as food for human consumption in (state country of origin).

B) Microbiological guidelines:

- (i) Total aerobic plate count: Not exceeding 50,000 organisms per gram of oyster meat.
- (ii) Most probable number: Not exceeding 3 per gram of oyster meat.  
*Escherichia coli*:

The Department of Health also monitors and limits the use of preservatives such as boric acid and sulfur dioxide in shrimp. Preservatives are not allowed in fresh fish.

For further information, contact:

Department of Health  
Hygiene Division  
Tel: (852) 2961-8809  
Fax: (852) 28933547  
Attn: Mr W.M. NG

■ **Department of Health Requirements**

Any food, intended for sale in Hong Kong, whether imported or locally produced must comply with the local food laws. Countries exporting food products to Hong Kong are expected to grow, harvest and process food according to the Code of Hygienic Practice recommended by the Codex Alimentarius Commission of the Food and Agriculture Organization of the United Nations, World Health Organization or other Good Manufacturing or Agricultural Practice of recognized standards as appropriate. The Health Department suggests that HACCP be used in the production of food products.

The Health Department tests for food adulteration including the maximum concentration of heavy metals including mercury, cadmium and arsenic. Samples for testing are purchased.

There are no specific temperature requirements for the storage and transport of food, however, chilled product should be held at -4°C or below.

The Health Department also monitors preservatives including boric acid and sulfur dioxide which are not allowed in fresh fish. Ascorbic acid (sorbic acid) is limited to 1,000 ppm.

Products destined for the sushi and sashimi market should be accompanied by a health certificate indicating that the product is “fit for human consumption in the raw state”.

In general, product is released within six (6) hours depending upon the number of consignments arriving. Plans are on-line to develop a computer system that will link the Department of Health with Customs and air cargo companies to move goods more rapidly. The Department of Health issues a release letter. This can be done electronically to speed movement of goods.

## **VIII. FISH AND SEAFOOD WHOLESALE MARKETING**

There are seven auctions for fresh fish and seafood in Hong Kong. The Aberdeen Wholesale Fish Market is the largest but it handles primarily domestic harvest. The auction at Kwun Tong Wholesale Fish Market handles live fish and seafood.

Much of the cultured product finds its way to the live fish and seafood dealers throughout Hong Kong. Live fish and seafood is placed in holding tanks at dockside or on barges usually adjacent to the major wholesale markets/auctions, where wet market retailers and restaurant distributors can buy fresh/chilled product at the same time that they buy live product. Live product imported from other producing countries is also sold from the same location. Once a selection is made, the live dealer delivers the product to the customer. The trucks are equipped with air compressors to provide air to the tanks built into the truck body.

Traditionally, in Hong Kong, fresh fish and seafood is that which is still swimming in the water at the time of purchase or that the heart is still seen pumping. The presence of *fresh* blood highlights the freshness of various finfish that have been split open to reveal their organs.

■ **Fish Marketing Organization** <[www.info.gov.hk/afd/fish/capture.htm#6-2-4](http://www.info.gov.hk/afd/fish/capture.htm#6-2-4)>

The Fish Marketing Organization (FMO), a non-trading body in Hong Kong, is a non-profit-making administered by the Director of the Agriculture and Department.

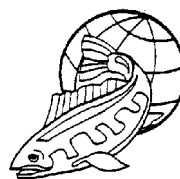

governmental  
organization  
Fisheries

The FMO provides orderly marketing for both fishermen and retailers of marine fish. Seven markets are run by the FMO. Revenue is obtained from a 7% commission on sales.

commercial  
wholesale fish

**Wholesale Fish Markets run by the FMO:**

Cheung Sha Wan Wholesale Fish Market	Tel: (852) 2307 8758
Kwun Tong Wholesale Fish Market	Tel: (852) 2775 5987
Sai Kung Wholesale Fish Market	Tel: (852) 2792 2735
Aberdeen Wholesale Fish Market	Tel: (852) 2552 8853
Shau Kei Wan Wholesale Fish Market	Tel: (852) 2568 6312
Castle Peak Wholesale Fish Market	Tel: (852) 2450 6445
Tai Po Wholesale Fish Market	Tel: (852) 2664 4208

**■ Permit to Transport Marine Fish**

Transportation of marine fish in Hong Kong is governed by Regulation 3 of the Marine Fish (Marketing and Exportation) Regulation, Cap 291. The regulation requires a Marine Fish Transportation Permit from the Director of Marketing, Agriculture and Fisheries Department for marine fish (excluding live marine fish) to be transported in excess of 60 kg on land or in the waters of Hong Kong. Any person who contravenes this regulation commits an offense and is liable to a fine of \$ 10,000 and to imprisonment for six (6) months.

Further Inquiries regarding the Marine Fish Transportation Permit contact:

Fisheries Officer,  
Fisheries Marketing and Economics Section  
Agriculture and Fisheries Department  
Tel: (852) 2 733 2206  
Fax: (852) 2 311 3731

**SEOUL, REPUBLIC of KOREA**

The Republic of Korea (ROK) is one of the major trading countries in the world. In implementing the World Trade Organization (WTO) agreement, the Korean government allowed all fish and seafood products to be imported into Korea in July, 1997. However, it does not imply removal of the regulations for relating to tariffs and safety inspection. Therefore, it is necessary for importers and exporters to obtain the latest requirements from the National Fisheries Products Inspection Station (NFPIS) and the Korea Food and Drug Administration (KFDA). The inspection regulations administered by the Ministry of Health and Welfare are specified under the Food Hygiene Law. The Permit Standards for Safety are found in the Food Hygiene Law and Food Additives Code.

## **I. GENERAL SHIPPING REGULATIONS**

(Be advised that shipping regulations change on a regular basis)

■ **Language** English, Korean

■ **Weights** Metric

■ **Currency** South Korean won (W)

■ **International Dialing Code** 82

■ **Public Holidays** The following are the official civic and religious holidays, when banks, offices and most shops may be closed. Most holidays fall on a fixed date every year, but some traditional holidays change according to the lunar calendar from year to year:

New Year	January 1
Lunar New Year	January/February
Independence Day	March 1
Labor Day (May Day)	May 1
The Buddha's Birthday	May 3
Children's Day	May 5
Memorial Day	June 6
Constitution Day	July 17
Liberation Day	August 15

Lunar Thanksgiving	September/October
National Foundation Day	October 3
Christmas Day	December 25

■ **Documents for Commercial Shipments**



(Please see the preparing the shipment chapter/glossary for further explanation of terms)

1. Commercial Invoice.  
Commercial Invoices are required in duplicate.  
  
All Commercial and Consular Invoices must include:
  - a) Place of shipment.
  - b) Port of origin.
  - c) Port of arrival.
2. Certificate of Origin.
3. Packing lists are required for most shipments.
4. Letter of Credit.
5. Sanitation (health) certificates may be required.
6. An air waybill made out to the order of an exchange bank designated by the importer, is required for nearly all shipments.
7. Country of Origin labeling or marking is required on every item. Korea enforces strict Country of Origin (COO) labeling. These regulations require that all imported goods be affixed with “easily readable” labels or stickers indicating country of origin. For standardization of labeling, the National Fisheries Products Inspection Station (NFPIS) offers instruction and performs monitoring functions. Often the importer will provide the seller with appropriate labels.

#### ■ Sample Shipments

Samples may be temporarily imported under the ATA Carnet system free of duty. Customs duties will be levied on items not re-exported within a six (6) month period. The license may be extended for a further six (6) months with approval from the appropriate authorities. Samples with no commercial value are admitted free of duty. Duty-free samples, which may not be sold or used for other purposes, must either be re-exported within a period of six (6) months or marked or spoiled so that they cannot be sold.

#### ■ Markings

All commodities must be labeled and marked in accordance with international practices (IATA) and local labeling requirements.

#### ■ Nomenclature

The common name of the fish and seafood species used on documents must be a name accepted by the Korean authorities. Importers can provide direction to suppliers on acceptable common names. Some exporters have indicated that the Korean government is extremely strict about labeling regulations. Therefore, it is imperative that exporters use the correct nomenclature for their products. A good resource is “The Dictionary of Aquatic Animals and Plants Name” [sic]. This book has colored plates and lists fishes by their Korean name with the corresponding English, Japanese and scientific names. Experienced importers often provide their suppliers with labels in both English and Korean that reflect the most current information required. It is also important to correctly identify the product form such as “head-on” or “head off.”

#### ■ Packing

No special packing considerations are involved for fishery imports into Korea. However, packing should be designed to prevent loss through damage, rough handling, pilferage, or deterioration. Sturdy boxes, with interiors and exteriors waterproofed, should be securely metal strapped, where appropriate.

#### ■ Insurance

Privately imported products are shipped either CIF or C& F according to arrangements made with the customer. Currently, the Korean government is encouraging Korean traders to insure imports with insurance firms. Today, more and more imports are being shipped C&F although CIF quotations are sometimes required.

#### ■ Import Clearance

Imported product clearance is available through Customs brokers from Monday to Friday between 09:00 and 18:00 and on Saturday, between 09:00 and 12:00. Special arrangements can be made for off hours clearance. Customs duties can be paid after obtaining the import license. Importers can pay Customs duties within 15 days following the import declaration.

For further details, contact the Seoul Main Customs House by telephone (82) 2 512 3100 and by Fax: (82) 2 3445 5721 or the Kimpo Main Customs House at the Kimpo International Airport by telephone: (82) 2 665 3100 and by Fax: (82) 2 660 5678.

The revised Customs Act (1994) allows the importer to make a pre-declaration before the goods arrive at the airport.

## II. TARIFFS

Korean tariffs vary according to Harmonized Commodity Code numbers. All tariffs on fish and seafood products are assessed on an ad valorem basis. The dutiable value of the goods is

normally the CIF price at the time of import declaration. Tariffs are payable before the goods are permitted to clear Customs. Duties are generally 10% for live and frozen fish and seafood and 20% for chilled/fresh and processed fish and seafood.

Korea sometimes applies “adjustment tariffs” to control imports. These are often used on live fish imports such as sea bass, loaches and sea bream. These tariffs may be 100% or less. For example, recent tariff adjustments on fish and seafood have included 100% on live sea bream, live sea bass, live loaches and 50% on live eel.

Korea’s tax system has been composed primarily of a value-added tax (VAT) and a special excise tax on luxury items. At present, a single flat rate of 10 percent is applicable on all imported items subject to the VAT (applied to the CIF value + Customs duty).

### **III. INSPECTION**

All fishery products are subject to sanitation inspection by the National Fisheries Products Inspection Station (NFPIS) or the Korea Food and Drug Administration (The National Quarantine Station) of the Ministry of Health and Welfare. The inspection may involve laboratory testing. However, there are no significant delays in the release of the product from Customs. The first shipment from a supplier is almost always subject to more precise inspections.

There are two organizations of inspection for imported fish and seafood products. One is inspection by the National Fisheries Product Inspection Station (NFPIS) and the other is inspection by either the Korea Food and Drug Administration or the National Quarantine Station under the Ministry of Health and Welfare.

The NFPIS inspects raw materials and primary processed products such as live finfish, shellfish and crustaceans as well as fresh, chilled, frozen, salted, smoked and dried fishery products. The Korea Food and Drug Administration and the National Quarantine Station inspects highly-processed products such as fish paste products and canned, bottled and seasoned products.

Since all imported live and fresh fish and seafood products are inspected by the National Fisheries Products Inspection Station, suppliers should be extremely familiar with food safety regulations, particularly the Korean Food Code and Food Additives Code. The amount of food additives allowable in products is specified in the “Official Book of Food Additives.” There is a list of 550 food additives approved for use in Korea. Tolerances are established on a product by product basis. The best sources of information on these topics as related to live and fresh fish and seafood products are reliable importers.

There are three kinds of inspection for fish and seafood products: 1) paper inspection; 2) physical (organoleptic) inspection, and; 3) precision (laboratory) inspection. The use of each depends upon import purpose, inspection history and the country exporting the goods. The NFPIS has

reduced the use of precision inspection and increased the use of paper inspection so that the freshness of the product might not be compromised by the time involved in the inspection process. If goods are determined to present a danger to consumers, then the NFPIS is authorized to take measures such as recalling the goods in accordance with the Fisheries Products Inspection Law and the Food Hygienic Law.

■ **Inspection Methods Used:**

Physical (organoleptic) Inspection -

Product state, taste, smell, color, markings and packaging state are examined.

Residual Heavy Metals -

Product is inspected for the presence of residual amounts of harmful heavy metals such as mercury, lead and total heavy metals.

Antibiotic Residuals -

Product is inspected for the presence of residual amounts of antibiotics such as oxytetracycline and synthetic disinfectants.

Radioactive Contamination -

Product is inspected for the presence of radioactive nuclear substances such as Cs<sup>134</sup>, Cs<sup>137</sup> and I<sup>131</sup>.

Natural Toxins -

Product is inspected for the presence of paralytic shellfish toxins and blowfish toxins.

Parasites -

Limited products, such as loach, are inspected for the presence of gnathostoma, spinigerum and other parasites.

#### **IV. SPECIFIC REGULATIONS FOR FISH AND SEAFOOD IMPORTS**

1. No certification is required but quarantine inspections are required when live/fresh fish and seafood arrive at the airport.
2. Finfish and lobsters cannot contain greater than 0.1 ppm of oxytetracycline.
3. Standards of allowable heavy metal residues for marine finfish and shellfishes:
  - a) Total amount of mercury: 0.5 mg/kg maximum (Deep sea caught finfish and shellfishes and most tunas are excluded from this provision).

- b) Lead: 2.0 mg/kg maximum.

#### **Heavy Metal Testing Criteria:**

Mercury testing is conducted according to standards set forth by the Association of Official Analytical Chemistry (AOAC). All marine products including live and fresh must undergo testing for mercury (meeting the standard of 0.5 mg/kg) and lead (meeting the standard of 2.0 mg/kg). Lead testing is more time consuming than mercury testing.

Fish and seafood inhabiting a depth of more than 200 meters are considered to be “deep marine fish.” According to the Ministry of Health and Welfare (MHW), deep marine fish include: *Sebastes* spp. *Alfonsino Berycoid* fish, queen crab, whelk, blue fin tuna, albacore, bigeye tuna, yellow fin tuna, sail fish, spear fish, black marlin, white marlin, swordfish, skip jack, little tuna, bullet mackerel, frigate mackerel, cow shark, cat shark, mackerel shark, bonito shark. The list is the same as the list provided in GATT notification 94.115, but excludes anglerfish and three or four other species.

4. Standards for allowable Paralytic Shellfish Poisoning (PSP) for shellfish and its products cannot exceed 80µg/100g maximum.

#### **■ Fishery Inspection Law**

Major revisions to the Fishery Inspection Law include:

- ! Strengthening the role of the National Fisheries Products Inspection Station (NFPIS) including implementation of Hazard Analysis Critical Control Point (HACCP) Inspection.
- ! Implementation of overseas registration system of domestic facilities in accordance with the standards set by the European Union countries and the United States to which Korean products are exported.
- ! Implementation of inspection for harmful insects and parasites.

## **V. EXPORT INSPECTION**

Previously, all fish and seafood products for export from Korea were inspected. However, since 1993, only items designated by the Ministry of Maritime Affairs and Fisheries for inspection (“obligatory inspection” items) and those designated by importing countries for inspection (“desired inspection” items) have been subjected to regular inspection. To determine which species are currently designated for inspection, Korean exporters should check with the:

National Fisheries Product Inspection Station  
192-7, ILSan 1-Dong, ILSan-KU, Koyang City, Kyunggi-Do, Korea  
Tel: (82) (0344) 976-1057  
Fax: (82) (0344) 976-1059

The NFPIS inspects locally produced products through testing for the presence of heavy metals, antibiotic substances, shellfish toxins and food-poisoning germs at the harvesting, unloading and auctioning stages.

## **VI. KOREA AND WORLD TRADE**

In September 1992, Korea agreed to abide by the General Agreement on Trade and Tariffs (GATT) and developed country commitments, such as notifying the World Trade Organization (WTO) proposed mandatory standards or regulations or changes to existing mandatory standards or regulations that affect trade. Korea also agreed to provide periods of public comment and adjustment by foreign firms before new standards and regulations go into effect. In January 1993, the ROKG issued a prime ministerial decree which mandates adherence of government agencies to GATT standards code procedures. The decree requires that all ROKG standards-making activities be transparent, subject to open and nondiscriminatory public review and comment, and consider the effect on trade and ability of firms to comply within the proposed time frame. Currently existing standards, testing and certification requirements are not affected by this new law.

## **VII. STANDARD KOREAN TRADE PRACTICES**

Korea imposes restrictions on credit terms. Sixty to ninety (60-90) day credit terms are restricted to items with a tariff rate of 10% or less. Use of deferred payment terms for other goods requires a license from the Foreign Exchange Bank and permission from the Governor of the Bank of Korea. Such permission is rarely granted.

There are two kinds of trading agents. One is the offer sales agent whose business is issuing offer sheets and conducting sales promotion activities on behalf of foreign suppliers on a commission basis. The other is a stock sales agent who is an actual importer or distributor and who imports and sells. Most agents request an exclusive contract to market the product(s) in Korea for at least one year.

Margins can vary depending upon the individuals or companies, the products, the season and competitive situation. Importers' margins are generally 10 to 20 percent.

In order to minimize difficulties with the Korean government, new importers are advised to meet with officials of the Korean Customs Service (KCS) at Kimpo Airport in Seoul. It is advisable to do this before large shipments are ordered. Bring samples of the product and request that KCS provide the tariff classification and rate of duty. Ask if there are any restrictions, special

documentation requirements or unique labeling requirements. Ask which, if any agencies will have control or authority over the processing and release of the products and meet with officials from these agencies.

The Korean Customs Service is actively seeking to facilitate fair trade and has designated a senior official at its headquarters to resolve problems. Issues that cannot be resolved through open discussions with the Customs office at the port of entry may be directed to:

Director General  
Cooperation Bureau  
Korean Customs Service  
920, Dunsan-Dong, Seo-Ku, Taejon 302-173, Korea

The Customs EDI Clearance System for Imports (CEDIM) has been in operation since July 1996. CEDIM enables traders, customs brokers, banks and other import-related bodies to file import declarations.

## **VIII. SELLING IMPORTED FISHERY PRODUCTS IN SEOUL**

With the full liberalization of fish and seafood imports, the two major fish and seafood markets in Seoul are establishing a new marketing channel for imported fish and seafood products. Importers will be allowed to establish market retail outlets so that they can sell imported products directly to consumers. This should significantly reduce retail prices since it will eliminate middlemen.

There are two other marketing channels available for imported fish and seafood products. The most common is auctioning of imported fishery products at the wholesale markets. Middlemen participate in the auctions on behalf of distributors. The product is then distributed to retailers such as fish stores, supermarkets and department stores. The other marketing channel is for importers to distribute the product directly to retailers or distributors.

### **REPUBLIC of KOREA CONTACT LIST**

Fishery Policy Bureau  
Ministry of Maritime Affairs and Fisheries  
826-14 Jinsol Building, Yuksam-Dong, Kangnam-Ku, Seoul, Korea  
Tel: (82) (02) 567-2674  
Fax: (82) (02) 567-2677

National Fisheries Product Inspection Station  
192-7, ILSan 1-Dong, ILSan-Ku, Koyang City, Kyunggi-DO, Korea  
Tel: (82) (02) 762-9211  
Fax: (82) (02) 976-1059

Overseas Development Department  
Agricultural & Fishery Marketing Corporation  
191, 2-Ka, Hangang Ro, Youngsan-Ku, Seoul, Korea  
Tel: (82) (02) 797-4022, 794-746-4044  
Fax: (82) (02) 790-5265

Korea Trade Investment Promotion Agency (Kotra)  
159, Samsung-Dong, Kangnam-Ku Seoul, Korea  
Korea Trade Center, P.O. Box 123  
Tel: (82) (02) 551-4181  
Fax: (82) (02) 551-4477

Korean American Business Institute  
808, Paiknam Building, 1-Ka, Ulchi-Ro, Chung-Ku, Seoul, Korea  
Tel: (82) (02)753-7750  
Fax: (82) (02) 752-6921

Noryangjin Fishery Wholesale Market  
13-8, Noryangjin-Dong, Tongjak-Ku, Seoul, Korea  
Fish Price Automatic Responses: Tel: (82) (02) 817-0621  
Purchasing and Forwarding Consultation: Tel: (82) (02) 814-5612  
Other Questions: Tel: (82) (02) 814-2211/9

Garak-Dong Agricultural & Marine Products Total Wholesale Market  
600, Garak-Dong Songpa-Ku, Seoul, Korea  
Tel: (82) (02) 202-8522  
Fax: (82) (02) 405-9595/408-6005

The American Chamber of Commerce in Korea  
Westin Chosun Hotel 2<sup>nd</sup> floor, 87 Sokong-Dong, Chung-ku, Seoul, Korea  
Tel: (82) (02)- 753-6471  
Fax: (82) (02)-755-6577

International Cooperation Division  
Ministry of Health and Welfare (MHW)  
1, Chungang-dong, Kwacheon-City, Kyunggi-Do, Seoul, Korea  
Tel: (82) (02)503-7524  
Fax: (82) (02)504-6418

Korea Deep Sea Fisheries Association  
Samho Building A-dong, 6<sup>th</sup> Floor  
275-1, Yangjae-Dong, Seocho-Ku, Seoul, Korea  
Tel: (82) (02) 589-1621/24



Fax: (82) (02) 589-1630/1

**National Fisheries Products Inspection Stations:**

Headquarters: 192-7, ILSan 1-Dong, ILSan-Ku, Koyang City  
Kyunggi-Do, Korea  
Tel:(82) (0334)976-1057  
Fax: (82) (02) 976-1059

Pusan: 10-4, 6-ka Jungang-dong, Jung-ku  
Pusan, Korea  
Tel: (82) (051)442-2801

Seoul: Cargo Terminal Annex, 2<sup>nd</sup> Floor, Konghang-Dong #281  
Kangseo-Ku, Seoul, Korea  
Tel: (82) (02)662-3682

Inchon: 30-16, 3-ka, Sinheng-dong, Jung-Ku, Inchon, Korea  
Tel: (82) (032)881-6066

Jumunjin: 316-2 Jumunjin-eup, Kangnung, Kangwon-do, Korea  
Tel: (82) (0391)662-2074

Janghang: 523, 2-ka, Changseon-dong, Janghang-eup  
Seachon-kun, Choongchung Nam-do, Korea  
Tel: (82) (0459) 956-0028

Yeosu: 100-9, Bongsan-dong, Yeosu, Cholla Nam-Do, Korea  
Tel: (82) (0662)41-6382

Mokpo: 8-5, Yu-dong, Mokpo, Cholla Nam-do, Korea  
Tel: (82) (0631) 43-0945

Wando: 782-55 Jungang-ri, Wando-eup, Wando-kun,  
Cholla Nam-Do, Korea  
Tel: (82) (0633) 54-2681

Pohang: 616, Duho-Dong, Buk-Ku, Pohang- City,  
Kyungsang Buk-Do, Korea  
Tel: (82) (0562) 231-0092

Tongyeong: 151-28, Hangnam-dong, Tongyeong,  
Kyungsang Nam-do, Korea  
Tel: (82) (0557) 645-3373

Cheju: 1306, Ildo-1Dong, Cheju City, Cheju-do, Korea  
Tel: (82) (064) 22-3396



# SINGAPORE



Singapore's economy relies on entrepot trade, ship building and repairing, oil refining, electronics and banking. Some agriculture exists - growing plants and vegetables, and some fishing. Most foodstuffs and raw materials are imported.

However, Singapore's economic activity more than compensates for its lack of natural resources. Singapore's natural harbor is considered its most valuable resource and is one of the world's busiest ports. Singapore is a major oil refining and distribution center and a leader in shipbuilding and repairing. It is also a leader in high technology manufacturing, particularly computer and telecommunications equipment. Singapore is regarded as an important communications and financial center for Asia with more than 140 banks.

Singapore consumers represent a vast host of cultures, many of which demand fresh and live fish and seafood products in their diets as a part of their national cuisine. In addition, Singapore's large tourism industry caters to world tastes, thus making the importation of fish and seafood products into Singapore a necessity.

## I. GENERAL SHIPPING PROCEDURES

(Be advised that shipping regulations change on a regular basis)

- **Language** Mandarin Chinese (national), Malay (official and national), Tamil (official), English (official and for commerce)
- **Weights and Measures** Metric
- **Currency** Singapore dollar (S\$)
- **International Dialing Code** 65
- **Public Holidays** The following are the official civic and religious holidays, when banks, offices and most shops are closed. Most holidays fall on a fixed date every year, but some traditional holidays change according to the Chinese lunar calendar from year to year. Not all Muslim festivals listed are national but will affect Muslim businesses. Muslim festivals

are timed according to local sightings of various phases of the Moon and the dates given are approximations. Hindu festivals are declared according to local astronomical observations:

New Year's Day	January 1
Chinese New Year	January - February
Hari Raya Puasa (end of Ramadan)	late February
Good Friday	March/April
Hari Raya Haji, Feast of Sacrifice	April
Labour Day	May 1
Vesak Day	May 25
National Day	August 9
Deepavali	October/November
Christmas day	December 25

#### ■ Documents for Commercial Shipments

(Please refer to the "Preparing the Shipment" chapter and glossary for further explanation of terms)

1. Commercial Invoice.

The combined commercial invoices of origin and value are required in duplicate. The invoices should include:

- a) Date of issue of the invoice.
- b) Name and address of the supplier.
- c) Name and address of the importer.
- d) Marks and number of packages.
- e) Gross and net weights and measurements for each package.
- f) Full description of goods.
- g) Total product value for Customs.

2. Annual Import License.

An annual import license issued by the Primary Production Department (PPD) is required for fish and fishery products (includes finfish, crustaceans and molluscs).

### ■ **Certificate of Origin**

A certificate of origin is not usually required unless specifically requested, it is tacitly assumed that the origin of the product is the exporting country.

### ■ **Sample Shipments**

Commercial samples, where liable to duty, may be admitted on deposit of duty, which will be refunded on re-exportation within one and six months. The use of ATA Carnets will be authorized for the temporary admission of goods in the following categories:

- 1) Commercial samples and advertising film.
- 2) Goods for international exhibits.
- 3) Professional equipment.

The guaranteeing organization is the Singapore International Chamber of Commerce.

### ■ **Packaging**

There are no known legal requirements stipulating specific packaging materials or sizes to be used for fish and seafood. However, it is advised that live products are packed under IATA guidelines.

### ■ **Labeling/ Marking Requirements**

It is recommended that exporters contact their Singapore importer directly to ensure that product specifications and labeling meet current regulations.

Please see Section V for further information on labeling requirements for molluscan shellfish products sold in Singapore.

## **II. TARIFFS**

Singapore pursues a free and fair trade policy. Other than a Goods & Services Tax (GST) which was introduced on April 1, 1994 for imported goods, very few goods are dutiable or under control.

There are no tariffs nor any non tariff barriers, other than the GST, for fresh and live fish and seafood shipped into Singapore.

### ■ **Goods & Services Tax (GST)**

The GST is levied on imported goods at the rate of 3% of the CIF value of the goods. Fish and seafood products are non-dutiable.

For imported non-dutiable goods which are removed to a bonded warehouse for storage or imported

under the major exporter scheme, the GST will be temporarily suspended. The GST is payable to Customs when the goods are removed from the bonded warehouse for local consumption. In the case of goods imported under the major exporter scheme, the importer must collect GST on local sales. The importer must account for this GST to the Internal Revenue Authority of Singapore (IRAS) during the accounting period concerned.

If the goods are deposited in the free trade zone (FTZ) pending re-export or transshipment, the GST payable is suspended. The GST is payable on goods used or consumed in the FTZ as well as on their removal into Customs territory for home consumption. GST is also payable on any supply made in the FTZ if the goods supplied are used or consumed in the FTZ. However, GST is not payable on any supply made in the FTZ if the goods supplied are meant for re-export or transshipment.

### **III. CUSTOMS CLEARANCE**

Customs clearance is available at Singapore Changi Airport through a clearing agent or the consignee. Regular Customs hours are Monday through Friday 8:30 to 17:00, Saturday 8:30 to 13:00. Twenty-four (24) hour Customs clearance service is provided to import/export deliveries with appropriate permits.

#### **■ Documents Required for Clearance of Cargo**

The following documents should be produced to Customs when goods are cleared from the Free Trade Zone (FTZ) in Singapore Changi Airport and when imported by road via the Woodlands Checkpoint:

- S** Customs permits, Trade Development Board (TDB) permits or joint Customs/TDB permits as appropriate.
- S** Invoices, packing lists, bills of lading/airway bills and any other supporting documentation.

Health documentation is not required for imports of live or fresh finfish. However, for molluscan shellfish, health certification is required (see Section V).

#### **■ Customs Declarations:**

Customs declarations are required for the movement of fish and seafood products into Singapore. The import declaration is sent to the Trade Development Board (TDB) which in turn sends it to the Primary Production Department (PPD) for approval which is returned to the TDB and the cargo is cleared.

Types of Customs Declarations include:

1) Inward declaration.

- S** For removal of goods from arrival points (including air) to licensed premises or other approved places of storage.

2) Trans-shipment declaration.

- S** For removal of goods:
- Imported by sea from vessels at anchorage to the Free Trade Zone (FTZ) for storage.
  - From the FTZ for re-export to foreign destinations.
  - From the point at which they arrive on import to another point at which they are to be re-exported (for example, from Peninsular Malaysia via Woodlands Checkpoint to Singapore Changi Airport).

3) Removal declaration.

- S** To cover movement of goods between licensed or approved premises within Customs territory (for example, from one licensed warehouse to another).

4) Payment declaration.

- S** For payment of duty and/or GST on goods which are to be consumed in Singapore.

5) Outbound declaration.

- S** To cover movement of goods from Customs territory (for example, removal of goods from licensed/approved premises for export or storage in the FTZ).

6) Duty exemption/GST Relief Certification.

- S** To cover movement of goods which are exempted from payment of duty/GST in Singapore.

7) Duty Exemption/GST Payment declaration.

- S** To cover movement of goods which are exempted from payment of Customs duty but GST payable.

**■ Processing and Approval of Customs Declarations**

In Singapore, all declarations for movement of goods are submitted and processed electronically through the TradeNet system. Only Singapore-registered companies may apply to declare permits through the TradeNet system.

Declarations can be made separately to the Trade Development Board (TDB) or Customs or jointly to TDB and Customs. Where a joint declaration is applied, it will first be routed



to TDB and then to Customs for processing. For goods which are subject to import controls, the declaration will, after processing by the TDB, be routed to the authority administering the controls before finally being transmitted to Customs for processing and approval. The declaration is forwarded to the Primary Production Department (PPD) for fish and seafood products approval.

To submit a TradeNet declaration, a trader has to be assigned a unique reference number. This number assigned to a Customs or joint declaration serves to identify a particular declaration. This reference number consists of three elements - the declaring company's Central Registration (CR) number, the date of transmission (YY MM DD) and the declaration's serial number. It is normally assigned automatically by the trader's software system.

Approved Customs permits are transmitted back to the trader who will print the permit, such as the Cargo Clearance Permit (CCP), at the trader's premises for clearance for the goods. The CCP must be signed by the declarant. Only one copy of the CCP is to be printed and used for cargo clearance.

A trader can use the TradeNet System to declare:

- i. A maximum of 50 items of goods in a Customs or Joint Customs/TDB declaration.
- ii. Mixed items of dutiable and non-dutiable goods in a Customs or Joint Customs/TDB declaration provided that the goods are:
  - a) Under one bill of lading/air waybill (except in the case of through transshipment).
  - b) To be released from the same place.
  - c) To be removed to one place of receipt.

#### ■ **Conditions of Declarations**

Traders are advised to carefully read the conditions imposed on the Cargo Clearance Permits for compliance. Declarants are also advised to make true and correct declarations when submitting declarations to Customs for approval. Singapore law provides penalties for noncompliance of conditions and false, wrong or incorrect declarations

#### ■ **Singapore Free Trade Zones (FTZ)**

There are seven Free Trade Zones in Singapore. Six are for cargo arriving via ocean freight, one for air cargo. The air cargo FTZ is the Singapore Changi Airport.

## **IV. TRADENET**

To facilitate trade, the Singapore Trade Development Board (TDB) simplified import and export procedures. Trade documents are processed through TradeNet - an electronic data interchange (EDI) system.

Traders have to use TradeNet to submit permit applications electronically to government bodies such as TDB, Customs & Excise Department and other competent authorities for processing and approval. If the application is approved, the permit will be issued electronically to the sender. The system is administered by Singapore Network Services PTE Ltd (SNS). It makes use of the concept of mailboxes and the SNS computer is the central mailbox exchange.

The SNS network provides the following facilities for TradeNet users:

1. Central Mailbox System for exchange mail.
2. Information Services.
  - " Cargo Information System Enquiry
  - " Database Services
  - " Company Billing Enquiry
3. Network Facilities.
  - " Password Management
    - # facility to change the password
  - " Message Manager (MM) Archive
    - # facility to retrieve lost permits (within a day)
  - " MM Acknowledgment
  - " Service Administrator Services

TradeNet facilitates Customs clearance, with most cargo cleared within three (3) hours. TradeNet allows products to be moved under control, when necessary, under a country or product basis.

For more information or to register as TradeNet user, contact Tel: (65) 778 5611

### **■ Central Registration Number**

All Singapore importers and exporters are required to register with the Import & Export Office for a Central Registration Number (CR No.) The CR may be applied for through the Internet, in person, by fax or through the post. If the CR is urgently required, apply through the Internet.

#### **Internet Application**

Internet access at: <<http://www.asiaconnect.com/TDB/TRS/crnum.html>>.  
Follow the directions given.

#### **Applying in Person**

Submit the application form completed and signed by the manager/sole proprietor/partner/Director of the company or establishment.

Bring a photocopy of the company's valid incorporation/registration certificate and the company's rubber stamp with the address. If the company is registered with the TDB or the Monetary Authority of Singapore (MAS), an approval letter from the TDB or MAS must accompany the form.

The application should be brought to the Import & Export Office at Bugis Junction Office Tower. The last application must be submitted before 4:30 p.m. during weekdays and 12:30 p.m. on Saturday.

### **Applying by Fax**

Fax a letter to the Supervisor, Import & Export Office of the TDB to request an application form for the CR Number. The fax number is: (65) 337 2061.

An application form will be sent via fax within four working hours.

Return fax the completed form to the Import & Export Office together with the valid copy of the company's incorporation/registration certificate. If the company is registered with TDB or MAS include the approval letter in the fax transmission.

### **Applying by Post**

Post the completed form together with a copy of the importing company's incorporation/registration certification to:

CR No. Application  
Imports & Exports Office  
Singapore Trade Development Board  
230 Victoria Street  
#07-00, Bugis Junction Office Tower  
Singapore 188024

### **■ After Office Hours Approvals for Air Cargo**

It is possible to submit applications to SAAA Cargo Services PTE Ltd or any cargo agent at the Singapore Changi Airfreight Centre for processing with full descriptions of the goods to be imported. The following should be attached:

- S** One copy of the invoice.
- S** One copy of the air waybill (AWB).

The cargo agent will key in the application for processing and approval through TradeNet.

After approval, collect the original first print of the Cargo Clearance Permit (CCP), a copy of the invoice and a copy of the air waybill. The cargo agent certifies the original first print of the CCP.

Delivery of cargo from the Free Trade Zone (FTZ), such as the Singapore Changi Airfreight Centre, will only be allowed if the approved CCP is shown to the Customs officer on duty.

## **V. INSPECTION**

Every import declaration for fish and seafood is transmitted to the Primary Production Department (PPD) for processing. If approved the declaration is returned to the TDB and goes onto Customs Clearance.

Every consignment of high risk fish and seafood will be detained for inspection and (bacteriological) testing at Singapore Customs. It is important to ascertain if the imported product falls into the high risk category by contacting the Primary Production Department. High risk products have been identified as raw oysters, cooked crab meat/prawns and cockle meat.

The Primary Production Department generally “auto approves” low risk imported fish and seafood products. If fish and seafood products are to be transshipped, the health certificate requirements are not looked at by Customs.

### **■ Primary Production Department (PPD)**

#### **RE: Import, Export and Transshipment of Fish and Seafood by Air Cargo**

The Primary Production Department’s (PPD) Import Control Section (ICS), Veterinary Public Health & Food Supply Division, is responsible for ensuring that Singapore’s supply of meat, fish, fresh fruits and vegetables is safe for human consumption, thus the PPD is charged with regulating the imports of these products.

#### **General Requirements for Importers:**

1. The importer must be registered or licensed by PPD. Application forms are available at ICS.
  - A S\$ 75.00 annual import license fee is required for fish and fishery products (includes finfish, crustaceans and molluscs).
2. The importer must be registered under the Business Registration Act or incorporated under the Companies Act. A copy of an up-to-date business profile printout from the Registry of Company and Business is required at the time of registration/licensing.
3. The importer must obtain a GIRO account for payment of fees.

4. There is no requirement for a permit to import, export or transship fish and fishery products (excluding species controlled under CITES).

**Requirements for Fish and Fishery Products:**

1. Fees.
  - S\$ 2.50 per declaration approved
2. The importer should submit the following supporting documentation for approval:
  - Health certificate (for high risk seafood which includes frozen oyster, cockle meat, cooked prawn/shrimp and crab meat).
  - Bills of lading/air waybills.
  - Invoices.
3. Every consignment of high risk seafood will be detained for inspection and testing.

Contact:

The Director  
Primary Production Department  
Ministry of National Development  
5 Maxwell Road  
#03-00 Tower Block  
MND Complex  
Singapore 069110  
Tel: (65) 3257616/3257652  
Fax (65) 22206068

■ **HACCP Certification**

The Primary Production Department (PPD) issues HACCP certificates for facilities that would like to be covered under this inspection system.

■ **Requirements/Conditions Governing Import of Oysters**

Singapore has strict regulations governing the importation of raw molluscan shellfish:

1. The import of chilled raw shucked oysters or chilled raw oyster meat into Singapore is strictly prohibited.
2. Frozen raw oysters may be imported into Singapore subject to the following conditions:
  - 2.1 Permission to Import:

Prior to import, permission to import must be obtained from the Veterinary Public Health & Food Supply Division, Primary Production Department.

- 2.2 The bacteriological guidelines for frozen oysters:
- a) Aerobic plate count      Less than 500,000 per gm
  - b) *Escherichia coli*        Less than 20 per gm
  - c) *Vibrio parahaemolyticus* Less than 100 per gm
  - d) Salmonella, Shigella      Nil in 50 gm  
and *Vibrio cholera*

2.3 Health Certificate:  
Every consignment must be accompanied by a health certificate issued by the relevant government authority of the country of origin stating:

- a) The oysters were harvested from approved waters and processed in an approved establishment/plant in a sanitary and hygienic manner.
- b) The oysters have not been treated with chemical preservatives or other additives injurious to health.
- c) The product is fit for human consumption.

2.3.2 The Health Certificate must also contain the following information:

- a) Description of the product and packaging (including brand/trade mark if any).
- b) Quantity by weight.
- c) Name and address of the processing establishment.
- d) Name (s) and address (es) of the harvesting area (s), if different from (c) above.
- e) Date of harvesting and/or freezing.
- f) Name and address of consignor.
- g) Name and address of consignee.

2.4 Labeling:

Individual packages of oysters in the consignment must be properly labeled with at least the following information:

- a) Product description and brand, if any.
- b) Name of consignee.

2.5 Inspection and Sampling:

2.5.1 Consignments which do not comply completely with the Health Certificate and Labeling requirements shall not be allowed for import.

2.5.2 All consignments will also be inspected and passed by the Department before the oysters can be released for sale. Samples for laboratory analysis will be taken without compensation, from each consignment imported according to the schedule below:

- a) Three (3) sample units for consignment that is less than 500 kg and individual package size that is more than 1 kg.
- b) Five (5) sample units for all other cases.
- c) Each sample unit shall be at least 500 gm and consist of an intact package (s).

3. Consignments of oysters found to contain chemical preservatives or other additives injurious to health or fail to comply with the bacteriological standards shall be rejected and must either be returned to the country of origin or destroyed.
4. Live oysters may also be imported into Singapore subject to the conditions of Paragraphs 2 & the Department reserves the right to collect samples, without compensation to the company, from any consignment for inspection and laboratory analysis.

■ **Other fish and seafood restrictions**

- S The import of chilled blood cockle meat into Singapore is strictly prohibited.
- S The import of chilled crabmeat (including chilled crab claws) into Singapore is strictly prohibited.

## **VI. SINGAPORE REGULATIONS**

### **RE: IMPORTATION OF FISH AND FISHERY PRODUCTS**

All imported foodstuffs have to be registered with the Food Control Department. Registration can be undertaken by sending or faxing to the Department a copy of the inward declaration that has been approved by the Singapore Trade Development Board (TDB). Registration covers a one-year period for a particular product.

## 1. DEFINITION

- 1.1 Fish refers to any of the varieties of marine, brackish water or freshwater fishes, Crustacea, aquatic Mollusca, turtles, marine sponges, trepang and any other form of aquatic life and the young and eggs thereof.
- 1.2 Processed fish means fish that has been cured, cooked, frozen or preserved in any manner and includes any product derived or manufactured wholly or in part from fish, and reference to processing fish shall be construed accordingly.

## 2. SOURCES OF SUPPLY AND IMPORT REQUIREMENTS

- 2.2 Fish and fishery products which are wholesome and fit for human consumption from any country unless otherwise mentioned may be imported/exported with a license. Please check with the Department for any countries suspended from import for outbreak of food-borne diseases). Economies which export molluscan shellfish to Singapore will have to meet the basic requirements of a shellfish sanitation program. Live oysters can only be imported from *Australia, Canada, France, Netherlands, New Zealand, United Kingdom and USA*.
- 2.3 Fish and fishery products may be inspected and sampled from time to time upon import. Import of frozen oysters, frozen cooked crabmeat, frozen cooked prawns and frozen blood cockle meat require health certification from the relevant Government authority of the country of origin and are subject to mandatory inspection, sampling and laboratory testing before sale. Live oysters are inspected and sampled on a random basis under the ongoing surveillance program to monitor the microbial quality. Health certificates for live and frozen oysters, frozen cooked crabmeat, frozen cooked prawns and frozen cockles have to contain the description of the product; quantity by weight; name and address of the processing establishment; name and address of harvesting area (for oysters); date of harvest and/or freezing (for oysters); name and address of consignor; and, name and address of consignee. The health certificates also have to certify that:
  - a. The products (specify) were harvested from approved waters (for oysters only) and processed in an approved establishment/plant in a sanitary and hygienic manner.
  - b. The product (specify) have not been treated with chemical preservatives or other additives injurious to health.
  - c. The product is fit for human consumption



### 3. APPLICATION FOR LICENSE AND CARGO CLEARANCE PERMIT

3.1 The importer of fish and fishery products is required to apply for an import, export or transshipment of fish other than ornamental fish license with the Primary Production Department at 5 Maxwell Road #02-00 Tower Block MND Complex, Singapore 06911- prior to import. The fee for the license is S\$75.00 per annum. Every consignment of fish and fishery products has to be declared on a cargo clearance permit through the TradeNet system and approved by the Department. The fee for the approval of each permit is S\$2.50. Both the license and permit fees are debited through GIRO from the importers account.

### 4. DOCUMENTS REQUIRED

4.1 The importer or declarant has to fax supporting documents such as invoices, and health certificates (if applicable) quoting the unique reference number of the TradeNet system to the Department via Fax No. (65)3257650 when sending cargo clearance permit for approval.

### 5. INSPECTION

5.1 An importer is required to contact the Food Inspection Services Branch of the Department (Tel. (65) 3257654) to arrange for inspection. The message for inspection is indicated on the cargo clearance permit. Products under detention for laboratory examination are not to be used, re-packed, sold or released for sale until endorsement of approval is given on the permit.

### 6. OTHER CONDITIONS

The import of oysters, cooked crabmeat, cooked prawns and blood cockle meat in chilled form is not allowed.

## **VII. SINGAPORE FOOD REGULATIONS**

### **RE: The Sale of Food Act (Chapter 283)**

The import of food into Singapore is governed by the Sale of Food Act 1973 and The Food Regulations 1988 and all subsequent amendments. The Food Control Department for the Ministry of the Environment enforces the legislation.

The following are excerpts from the “The Sale of Food Act” that apply to the sale of fish and seafood into Singapore:

*No person shall sell, expose or offer for sale, consign, deliver or import any meat, poultry, fish, fruit or vegetable in the raw or unprocessed state, which has in it or on it*

*(otherwise than for the purpose of marking) any added coloring matter except that the husk of any nut may have on it added permitted coloring matter.*

*Sequestrants:*

*In these Regulations, "sequestrant" means any substance which, when added to food, combines with a metal ion in the food and renders the metal ion inactive so as to stabilize certain characteristics associated with the food, including color, flavor and texture.*

*Permitted:*

*(3) Citric acid, phosphoric acid and tartaric acid or the calcium salts of the above-mentioned acids, as well as glycine may be added to food to serve as sequestrants.*

*(4) Calcium disodium ethylenediaminetetraacetate may be used only in:*

*(a) canned fish, including crustaceans at a level not exceeding 250 ppm.*

*No person shall import, sell, advertise, manufacture, consign or deliver any article of food containing arsenic, lead and copper in amounts in excess of those specified in the Eleventh Schedule:*

*(B) Other Food*

*(2) Canned fish and meat, meat extract and hydrolyzed protein:*

*Arsenic 1 ppm*

*Lead 2 ppm*

*Copper 20 ppm*

*(15) Fish, crustaceans and molluscs:*

*Arsenic 1 ppm*

*Lead 2 ppm*

*Copper 20 ppm*

*No person shall import, sell, advertise, manufacture, consign or deliver any fish or fish product containing mercury in excess of 0.5 ppm or any article of food containing mercury in excess of 0.05 ppm.*

*The importation or sale of food which has been exposed to ionizing radiation is prohibited except under a license issued specifically for that consignment of food from the Director.*

*Part IV Standards and Particular Labeling Requirements for Food.*

71. *Fish shall be any edible and wholesome part of any marine or freshwater animal, other than a mammal, that is ordinarily used for human consumption, and shall include crustaceans and molluscs.*

72. *Fresh or chilled fish shall be fish which has been maintained in a wholesome condition without any part having been frozen.*
73. *Frozen fish shall be fish which has been subjected to a freezing process specifically designed to preserve the wholesomeness and quality of the product and maintained in a wholesome condition at a temperature of below -15° Centigrade except during frozen storage defrosting cycle or during transfer from the delivery vehicle to the frozen fish store on frozen fish display unit. The temperature of the frozen fish shall at no time exceed -12° Centigrade.*

*First Schedule*

*Fees for Analysis, Certificates, etcetera:*

- |  |      |  |
|--|------|--|
| 1. <i>Analysis of any food or appliance under section 8 of the Act (including the fee for the prescribed certificate of the results of the analysis where such certificate is given)</i> | .... | <i>The fee chargeable by the Director of Scientific Services</i>   |
| 2. <i>Copy of the results of analysis under section 10(2) of the Act</i>   | .... | <i>S\$ 20 per copy</i>   |
| 3. <i>Food (Export) Certificate</i>  | .... | <i>(a) S\$ 60 per certificate (in duplicate) per consignment<br/>(b) S\$5 per additional copy of certificate</i> |
| 4. <i>Food (Inspection Certificate)</i>  | .... | <i>S\$60 per certificate</i>   |
| 5. <i>Certified true copy of official documents</i>  | .... | <i>S\$5 per copy</i>   |

*Second Schedule.*

*Permitted Use of General Terms in the Declaration of Ingredients:*

*The following substances may be designated by generic terms in the list of ingredients:*

<i>Substance</i>	<i>Generic Term</i>
<i>Fish when forming an ingredient of fish products</i>	<i>Fish</i>

*Tenth Schedule.*

*Food with Maximum Amounts of Pesticides:*

<i>Substance</i>	<i>Maximum residue limit (ppm)</i>	<i>Type of Food</i>
<i>Aldrin</i>	<i>0.2</i>	<i>Fat of meat, fish (edible portions) milk and milk products (fat basis)</i>
<i>Lindane</i>	<i>1</i>	<i>Fish, beans (dry), cocoa beans, cocoa mass, radishes</i>
<i>Pyrethrins</i>	<i>3</i>	<i>Cereal grains, fish (dried)</i>

*Twelfth Schedule.*

*Microbiological Standard for Food:*

<i>Type of Food</i>	<i>Total Count at 37° C for 48 hours</i>	<i>Coliform Count</i>
<i>Cooked crab meat, prawns and shrimp</i>		<i>Not more than 500,000 per gram</i>
<i>Molluscs, ready for consumption</i>		<i>not more than 500,000 per gram</i>
<i>Fish, ready for consumption</i>		<i>not more than 100,000 per gram</i>

## **VIII. SINGAPORE FISH AND SEAFOOD MARKETING**

To facilitate the import of fresh and live fish and seafood to meet the increasing domestic demand and better utilize Singapore's position as a major port, a 17-hectare commercial fishery terminal complex with fish docks and a wholesale market was established in Jurong in 1969. Fish

processing plants, cold storage and ice manufacturing plants are located at this site. The wholesale market handles about 250 tons of fresh fish each day.

Exports of fresh and chilled fish are mainly for markets within the region. Imports consist mainly of fresh and frozen marine fish, shrimp, tuna and cephalopods.

Singapore has an open and transparent distribution system. The distribution chain is often very short with importers acting as distributors and agents, directly dealing with retailers. Supermarkets and hypermarkets are often direct importers making the distribution chain even shorter.

Retailers and supermarkets/hypermarkets generally charge slotting or listing fees for shelf space. The supplier may be expected to pay an extra discount in relation to the amount of chiller space required. An administrative fee of S\$10,000 may also be required. In general retail price margins for chilled product are about 20-25%.

**ADDITIONAL SINGAPORE CONTACTS:**

Seafood Industries Association

BLK 1003 #02-19/11

Bukit Merah Central

Singapore 159836

Tel: (65) 278-2538

Fax: (65) 278-7518

Singapore Fish Merchant General Association

35 Fishery Port Road

413 Fish Merchant Office Building

Singapore 619742

Tel: (65) 265-0051

Fax: (65) 266-2585

Primary Production Department

Ministry of National Development

5 Maxwell Road

#03-00 Tower Block

MND Complex

Singapore 069110

Tel: (65) 325 7616/325 7652

Fax: (65) 2 220-6068



## Tokyo, JAPAN

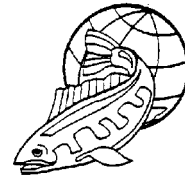

Japan is a highly competitive market with consumers who have been traditionally willing to pay a high price for quality. But as willing as the Japanese consumer has been to pay these higher prices and their tolerance for high cost consumer goods, products are increasingly selling at lower prices and value. Discount retailing is flourishing. It is believed that cost consciousness is partly due to long term uncertainty about the economy, especially job security, and partly due to increased awareness of high prices in Japan compared to those in overseas markets. This trend in decreased prices may soon apply to certain fish and seafood products as well.

### I. GENERAL SHIPPING PROCEDURES

(be advised that shipping regulations change on a regular basis)

■ <b>Language</b>	Japanese (national and commerce), English (commerce)
■ <b>Weights and Measures</b>	Metric
■ <b>Currency</b>	yen ¥
■ <b>International Dialing Code</b>	81
■ <b>Public Holiday:</b>	Note: a) If a holiday falls on a Sunday, the following day is treated as a holiday. b) Over the New Year, many businesses are closed January 1-3.
	New Year's Day January 1
	Coming of Age Day January 15
	National Foundation Day February 11
	Vernal Equinox Day March 20
	Greenery Day April 29
	Constitution Memorial Day May 3
	Children's Day May 5
	Day of the Sea July 20
	Respect for Aged Day September 15
	Autumnal Equinox Day September 23
	Sports Day October 10



Culture Day	November 3
Labour Thanksgiving Day	November 23
Birthday of the Emperor	December 23

## ■ Commercial Shipments

(Please refer to the “Preparing the Shipment” chapter and glossary for further explanation of terms)

Any person wishing to import goods into Japan must declare them to the Director-General of Customs and obtain an import permit after necessary examination of the goods concerned. The formalities start with the lodging of an import declaration and end with the receipt of an import permit after the necessary examination and payment of Customs duty and excise tax. More than 90 percent of import clearance is computerized.

### 1. Commercial Invoice and Export Packing List.

The commercial invoice and export packing list is required in triplicate. The exporter or an international freight forwarder on behalf of the exporter can prepare the documents. Documents should include:

- a) Marks.
- b) Numbers.
- c) Names and addresses of the consignor and consignee.
- d) Full description of goods.
- e) Quantity and value of goods.
- f) Harmonized Commodity Code.
- g) Place and date of the invoice.
- h) Conditions of contract relating to the value of the goods.
- i) Shippers signature.

Copies are submitted to the Customs office. Remember to list every product, quantities for each product, each unit price, and total value for the invoice. Prices and total value must clearly indicate whether they are FOB or CIF. A packing list must include the names of every product (if practical, scientific names should be added), and the quantities of each product. All numbers on the invoice and packing list must match.

### 2. Shipper’s Export Declaration.

A shipper’s export declaration should be prepared in the exporting country before shipping products to Japan. Copies should be forwarded to the appropriate governmental agencies. In many instances this document is prepared and forwarded to the appropriate agencies by international freight forwarders on behalf of the exporter.

### ■ Certificate of Origin

Certificates of Origin are not required for goods for which conventional and beneficial rates of duty are claimed, for example, goods which are entitled to GATT or Most Favored Nation rates of duty. A declaration of origin in the Commercial Invoice is sufficient for this purpose. However, goods originating from a third country may require a Certificate of Origin.

Some Japanese importers may request a certificate of origin whether the government requires one or not. The Japanese government requires a certificate of origin for any marine products listed in CITES appendices.

### ■ Air Waybill

An air waybill should be prepared by either an international freight forwarder or the air cargo carrier. Upon the arrival of the shipment in Japan, the air cargo carrier will forward the shipment to a Customs broker designated by the importer, and the air waybill will be used to claim the shipment from the air cargo carrier.

### ■ Insurance Certificate

Insurance is not required by the Japanese government. Insurance coverage should be decided between exporters and importers. It may be difficult to obtain insurance coverage since most policies do not cover live fish and seafood due to the high mortality risk.

### ■ Health Certificates

Health certificates are required when a product is being imported from an area designated as high risk by the Japanese government.

### ■ Import License

Some fish and seafood products are subject to an import quota (IQ) system. Under the IQ system, the importer must first obtain an IQ allocation Certificate from the Ministry of International Trade and Industry (MITI) which entitles him/her to receive an import license on Application to an authorized foreign exchange bank

### ■ Customs Clearance

Customs clearance at the Tokyo International Airport is available Monday-Friday from 8:30-17:00. Saturday 8:30-12:30. Closed Sundays and National Holidays. Out of hours clearance is available Monday through Saturday.

### ■ Packaging

Hay and straw are prohibited as packaging materials.

### ■ Labeling

Bags, sacks, containers or retail packages of fish and seafood products shall be labeled with Japanese words required by the Ministerial Ordinance before selling, displaying with intent to sell or using in business. For instance, retail or wholesale packaged fresh oysters must have a label that indicates: 1) the name of the product, for example, "Namakaki (Fresh Oyster)," "Karatsuki namakaki (fresh oyster in shell)," and so forth.; 2) the use by date; 3) the name and address of the processor; 4) all food additives used; and, 5) storage instructions. For raw oysters or shucked fresh shellfish, a statement of whether or not the product is intended to be consumed raw must be included.

For raw oysters or a frozen product of filleted fish or shucked fresh shellfish a statement of whether or not the product is intended to be consumed raw is required.

#### ■ Disposition of Import Documents

The package containing the commercial invoice, export packing list, air waybill and optional documents (insurance certificate, certificate of origin and health certificate) etcetera, usually accompanies the cargo. Normally this is arranged by the international air freight forwarder or can be completed by the exporter.

Upon arrival in Japan, a Japanese Customs broker engaged by the importer receives the cargo from the air cargo carrier. The broker facilitates Customs clearance on behalf of the importer by preparing necessary documents such as a food import declaration for the Ministry of Health and Welfare (MHW), arranges product inspection for the Quarantine Office and Customs Office, and advances import duties. The imported products are then forwarded to a warehouse or central wholesale market designated by the importer.

The above document package is also presented to the importer's bank to release funds from the importer's account if a letter of credit has been established.

## II. SHIPPING SAMPLES

There are three methods of importing samples into Japan:

- 1) Import with no limitation on the place, time or period of use of the samples. In certain cases, commodity tax must be paid, except when total value is less than 10,000 Yen or where the samples are of little individual value. In these cases samples are to be clearly identified so that they cannot be sold. No import license is required for gift imports of import quota (IQ) items not exceeding 180,000 Yen in total value.
- 2) Import by ATA Carnet. No import duty and commodity tax will be required, provided that the samples are not for sale and are to be re-exported within one year, for example products for demonstration or exhibit use. The ATA Carnet has to be arranged before the goods have left the country of origin.

- 3) Where such articles do not have an ATA Carnet, they may be imported duty and tax free provided that a bank guarantee equal to the duty payable is presented to Customs. A Customs broker in Japan is essential to carry out these transactions.

### **III. TARIFFS**

Tariffs are administered by the Customs Bureau of the Ministry of Finance. Japan's tariff schedule has four columns of applicable rates: general, GATT, preferential and temporary. Japan's preferential system of tariffs grants lower or duty-free rates to products from developing countries.

#### **■ Import Taxes**

In addition to the Customs duty, a 3% consumption tax (general excise tax) is levied on all goods sold in Japan and payment is required at the time of import declaration. The consumption tax is assessed on the CIF value of the product plus the import duty.

Duties and consumption tax are payable when making an import declaration at the time of Customs clearance by the importer. The Import Declaration Form (Customs Form C 5030) is filled out by the importing company and is used as an import declaration form. Packages containing items with a value of 10,000 Yen or less are exempt from the duty and the consumption tax.

#### **■ Customs Valuation**

Tariff duties are assessed on the CIF value ad valorem or specific rates, and, in a few instances are charged a combination of both. Check with the importer to determine the tariff duties.

#### **■ Import License/Import Quota**

Many goods qualify as "freely importable" and do not require an import license. However, some species of live and fresh fish and seafood products are subject to an import quota (IQ) system. Under the IQ system, the importer must first obtain an IQ Allocation Certificate from the Ministry of International Trade and Industry (MITI) which entitles the importer to receive an import license on application to an authorized foreign exchange bank

#### **■ Marine products on the Japanese import quota (IQ) list**

HS 0301.99-210 Live Fish for Aquaculture

- a. Herring (*Clupea* spp).
- b. Cod and cod-like fish (*Gadus* spp, *Theragra* spp, and *Merluccius* spp).
- c. Yellowtail and amberjack (*Seriola* spp).
- d. Mackerel (*Scomber* spp).
- e. Sardine and Anchovy (*Etrumeus* spp, *Sardinops* spp, and *Engraulis* spp).
- f. Jack mackerel (*Trachurus* spp and *Decapterus* spp).

- g. Saury (*Cololabis* spp).
- HS 0302.40-000: Fresh herring (*Clupea harengus* and *C. pallasii*).
- HS 0302.50-000: Fresh cod and cod-like fish (*Gadus morhua*,  
*G. ogac* and *G. macrocephalus*).
- HS 0302.61-010: Fresh sardine (*Sardinops* spp).
- HS 0302.61-090:
  - a. Fresh sardine (*Sardina pilchardus*).
  - b. Sardinella (*Sardinella* spp).
  - c. Brisling or sprats (*Sprattus sprattus*).
- HS 0302.64-000: Fresh mackerel (*Scomber scombris*, *S. australasicus* and *S. japonicus*).
- HS 0302.69-011: Fresh yellowtail and amberjack (*Seriola* spp).
- HS 0302.69-012: Fresh cod and cod-like fish (*Gadus* spp, *Theragra* spp and  
*Merluccius* spp).
- HS 0302.69-013: Fresh horse mackerel (*Trachurus* spp And *Decapterus* spp).
- HS 0302.70-020: Fresh hard roes of cod and cod-like fish (*Gadus* spp, *Theragra* spp  
and *Merluccius* spp).
- HS 0304.10-110: Fresh fillets
  - a. Herring (*Clupea* spp).
  - b. Cod and cod-like fish (*Gadus* spp, *Theragra* spp, and *Merluccius* spp).
  - c. Yellowtail and amberjack (*Seriola* spp).
  - d. Mackerel (*Scomber* spp).
  - e. Sardine and Anchovy (*Etrumeus* spp, *Sardinops* spp, and *Engraulis* spp).
  - f. Horse mackerel (*Trachurus* spp) and *Decapterus* spp).
  - g. Saury (*Cololabis* spp).
- HS 0304.10-190: Fresh fish meat (with the exception of fillets):
  - a. Herring (*Clupea* spp).
  - b. Cod and cod-like fish (*Gadus* spp, *Theragra* spp and *Merluccius* spp).
  - c. Yellowtail and amberjack (*Seriola* spp).
  - d. Mackerel (*Scomber* spp).
  - e. Sardine and Anchovy (*Etrumeus* spp, *Sardinops* spp, and *Engraulius* spp).
  - f. Horse mackerel (*Trachurus* spp and *Decapterus* spp).
  - g. Saury (*Cololabis* spp).

- HS 0307.21-000: Live, fresh or chilled scallops (*Pecten* spp, *Chlamys* spp, and *Placopecten* spp) including queen scallops.
- HS 0307.41-090: Live, fresh or chilled cuttlefish (*Sepia officinalis*, *Rossia macrosoma*, and *Sepiolo* spp) and squid (*Ommastrephes* spp, *Loligo* spp, *Nototodarus* spp, and *Sepioteuthis* spp), with the exception of kisslip cuttlefish (*Sepia lycidas*).
- HS 0307.91-200: Fresh adductors of shellfish (*Sepia officinalis*, *Rossia macrosoma*, and *Sepiolo* spp). And squid (*Ommastrephes* spp, *Loligo*, *Nototodarus* spp, and *Sepioteuthis* spp) with the exception of kisslip cuttlefish (*Sepia lycidas*).
- HS 0307.91-390: Live, fresh or chilled squid and cuttlefish with the exception of kisslip cuttlefish *Sepia lycidas*-, *Ommastrephes* spp, *Loligo* spp, *Nototodarus* spp, and *Sepioteuthis* spp.

#### ■ Import/Export Documentation

Customs procedures have been simplified. However, a number of documents are still required for clearance including:

- For import quota items, an import license, usually valid for six months from date of insurance.
- An Import Declaration Form ( Customs Form C 5030).
- Shipping documents such as a commercial invoice, packing list, and an original and shipped air waybill (shipments by air).
- A certificate of origin if the goods are entitled to favorable duty treatment.
- Any additional documents necessary as proof of compliance with relevant Japanese laws and standards regulations, if applicable.

#### ■ Free Trade Zones/Warehouses

Japan has no free trade zones. There are however, different types of bonded areas.

#### ■ Bonded Areas

##### 1) Designated Bonded Area

A designated bond area is a public space authorized by the Ministry of Finance. In these areas, located near ports of entry, foreign cargo (shipments to be exported, to be imported and in transit) can be unloaded, transported, and stored up to one month, This temporary space is used for Customs declaration and handling , and can be used by anybody for a fee.

2) Bonded Shed

This is a space authorized by the Director General of Customs Houses and it performs the same function as a designated bonded area.

3) Bonded Warehouses

Foreign cargo can be stored at bonded warehouses for up to two years ( and longer with special permission). As long as cargo is stored in a bonded warehouse, Custom duty is not applied.

4) Bonded Factories

Bonded factories allow manufacturers to produce goods with foreign materials without paying Customs duties on those foreign materials.

5) Bonded Exhibition Sites

This is exhibition space authorized by the Director General of Customs House for an international event. Foreign cargo can be exhibited or used with simple declaration. Equipment and materials to be displayed at a bonded exhibition site should be identified as such and arrangements must be made with the freight forwarder prior to shipment.

#### IV. CUSTOMS INFORMATION <[www.mof.go.jp/~customs/iport-e.htm](http://www.mof.go.jp/~customs/iport-e.htm)>

##### ■ Customs and Tariff Bureau

The Customs and Tariff Bureau is an internal bureau of Japan's Ministry of Finance. The role of the Customs administration includes:

1. Taxation

Customs collects Customs duties, consumption tax, tonnage dues and special tonnage levied on the net tonnage of ships engaged in international trade, and performs the post-entry examination after the completion of import clearance in order to check whether the importer's declaration was true and correct.

2. Customs Clearance

Under the Customs Law, any person who is to export or import goods shall so declare to the Director-General of Customs. Customs checks the legitimacy of export and/or import declarations and examine goods as required.

3. Surveillance and Control

Enforcement activities are conducted 24 hours a day.

#### 4. Supervision of Hozei Areas

Customs supervises hozei areas, such as hozei warehouses and hozei manufacturing warehouses, in which collection of Customs duty, consumption tax and so on is temporarily reserved.

Contact:

Tokyo Customs House  
5-5-20 Konan Minato-ku  
Tokyo 108 Japan  
Tel: (81) 3 3472 7000

#### ■ Customs Counselor System (CCS)

The Customs Counselor System (CCS) is available to provide the correct information on import and export procedures to concerned parties. The CCS will mitigate misunderstandings and if necessary, amend or improve import and export procedures via consultation or by hearing complaints.

Contact:

Customs Clearance System  
Tokyo Air Cargo Terminal Sub-branch Customs  
Tel: (81) 3 473 29 0605

## V. EXPORTING LIVE & FRESH FISH and SEAFOOD

### RE: General Market Conditions

#### ■ Auction Houses and Markets

In Japan, auction houses at central wholesale markets in major cities import fish and seafood on a consignment basis for auction and remit the payment to exporters about one week after deducting a 5.5% commission, import duties, trucking charges, etcetera. Other auction houses outside major cities may not engage in direct importing but they can auction fish and seafood imported by other import agents. Tsujiki Market in Tokyo is the largest and most famous wholesale market/auction in Japan.

Auction houses are authorized by the Ministry of Agriculture, Forestry and Fisheries to make consignment or own-account sales through (a) auction house bidding or (b) negotiated sales to middle buyers and authorized wholesale buyers. Auction house sales commission at central wholesale markets is fixed at 5.5% for marine products. Auction house sales commissions at landing ports is around three percent 3%.



Tsukiji Market is closed on Sundays, all national holidays and specific customary holidays such as the first three days in January. Auction companies should be able to supply calendars with the holidays and closed days specified.

Japan is a demanding market. Therefore, it is important to send only high quality product if planning to sell on consignment. It is also important to determine the quality parameters required by Japanese buyers.

#### ■ Shipping Process and Cost Analysis

The cost of shipping live/fresh fish and seafood products to Japan will include:

**Product Cost + Freight Charges + Insurance + 3 % GST based on the CIF price and import duty + import duty + Customs Clearance Charge and Miscellaneous Costs + Trucking Charges from Airport + 5.5 % Commission on final sale price.**

If an exporting company determines that it can deliver high quality live/fresh fish and seafood to the Japanese market, the next step is to contact the auction houses (companies) to determine if interest in the product exists. If the auction house is interested, begin the process by sending preliminary shipping information by fax to the selected auction house(s). Include the air flight number, country (region) of origin, quantity and weight of the product being sent. After the shipment has been sent, secure a copy of the commercial invoice, packing list and air waybill number from the freight forwarder. Transmit this information to the auction house by fax as soon as possible. This is absolutely necessary so that the auction company can arrange customs clearance, trucking, etc. for the shipment. It is critical that the auction company make arrangements to pick up the shipment as soon after it arrives as possible. This is a period of time when product is often left on the tarmac and not in refrigerated space.

The exporting company should pay careful attention to the arrival schedule of its product at the Tokyo International Airport. Avoid flights that arrive on Saturday afternoon (auctions are closed on Sunday) or the day before holidays. Remember auctions are held early in the morning.

The general method of payment is by either letter of credit (LC) or a direct cash wire.

## V. DISTRIBUTION SYSTEMS FOR VARIOUS SPECIES

- 1) Exporter auction house middlemen restaurants/retailers consumers (tuna, fluke, tilefish, grouper, northern shrimp, sea urchin roe, oysters, king crab monkfish liver, etc.)

- 2) Exporter import agent/importer auction house middlemen  
Restaurants/retailers consumers (tuna, fluke, tilefish, grouper,  
northern shrimp, sea urchin roe, abalone, oysters, blue crabs, etc.)
- 3) Exporter importer/distributor restaurant/retailer consumers  
(lobster, rock lobster, Dungeness crab, abalone, sea urchin roe,  
cherrystone clams)

## VII. IMPORT REGULATIONS

### RE: RESTRICTED SPECIES

The following is a listing of species that are import restricted into Japan:

Sailfish (*Erilepis zonifer*), Escolar (*Lepidocybiun flavorunneum*) and Oilfish (*Ruvettus pretiosus*), prohibited due to toxicity of glycerides and wax esters.

Blowfish, prohibited due to toxicity **with the exception** of the following species harvested in the Japan Sea, Pohai Sea, Yellow Sea and East China Sea: *Fugu niphobles*, *F. poecilonotum*, *F. pardale*, *F. vermiculare vermiculare*, *F. vermiculare porphyreum*, *F. ocellatus*, *F. chrysops*, *F. ruberipes ruberipes*, *F. ruberipes chinensis*, *F. xanthopteron*, *F. stictonotum*, *F. flavidus*, *Lagocephalus laevigatus inermis*, *L. wheeleri*, *L. gloveri*, *Liosaccus pachygaster*, *Chilomycterus affinis*, *Diodon holocanthus*, *D. liturosus*, *D. hystrix*, *Ostracion cubicus*.

Live crawfish (*Pacifcastacus sculus*), prohibited for import due to the possibility of rice plant and rice paddy destruction from crawfish feeding on plant roots and other dike vegetation.

Pink conch (*Strombus gigas*) which is listed in Appendix II of CITES must be accompanied by an export permit document or a certificate of re-export when exported to Japan.

Whole Dungeness crab (*Cancer magister*) must contain less than 20 ppm of domoic acid in the viscera. Whole Dungeness crab and Baird Tanner crab harvested in northern waters must contain less than 80µg/100 grams of Paralytic Shellfish Poison (PSP) in the viscera.

*Plectropomus oligacanthus*, *Epinephelus fusogutatus*, Moon tail seabass or Louti (cherry) grouper (*Variola louti*), Red Mumea (*Lutjanus bohar*), Humpback red snapper (*Lutjanus gibbus*) and Barracuda (*Sphyraena barracuda*) are prohibited due to ciguateric toxins.

In addition:

- Oysters for raw consumption are allowed from those areas which have developed an oyster export program in compliance with the Ministry of Health and Welfare requirements.
- The Ministry of Health and Welfare routinely inspects sea urchin roe.
- During the summer (July 1-October 31) the Ministry of Health and Welfare operates an annual monitoring program for *Vibrio parahaemolyticus* in sea urchins and bivalves for raw consumption.

## VIII. SPECIES SPECIFIC DOCUMENTATION

### ■ CITES Listed Species

When exporting species listed in CITES Appendices to Japan, they must be accompanied by an export permit document or a certificate of re-export. In the United States, these are issued by the Fish & Wildlife Service of the United States Department of the Interior.

### ■ ICCAT Bluefin Tuna Statistical Document

Pursuant to the 1992 International Commission of the Conservation of Atlantic Tuna (ICCAT) recommendations, each Atlantic Bluefin tuna must be accompanied by an ICCAT bluefin Tuna Statistical Document. Although this document is intended to accompany Atlantic bluefin tuna, the Japanese government also requires this document for Pacific bluefin tuna.

## IX. FISH AND SEAFOOD HYGIENIC REQUIREMENTS

### ■ Japanese Food Sanitation Law (the Law)

The Japanese Food Sanitation Law is designed to prevent health hazards arising from food and to promote safe and proper handling of food. Both imports and foods produced in Japan are subject to this law.

In accordance with Article 16 of the Law, importers are required to submit “Notification of Importation of Food, Etc.” to the Quarantine Station on behalf of the Minister of Health and Welfare (MHW) immediately after the arrival of the shipment in a Japanese port, by using a designated form.

While most items of the notification form can be completed from ordinary import/export documents such as the invoice and air waybill, some information must be supplied directly

to the importer. Some of this information concerns food additives. It is wise to determine whether or not specific additives may be used prior to export.

An import notification submitted to the Quarantine Station is examined by food sanitation inspectors to determine whether the shipment meets standards based on the Law.

If and when MHW finds the notification acceptable, MHW will inspect the goods if necessary. If and when the inspection is completed with satisfactory results, the Customs clearance will follow.

#### ■ Hygienic Inspection

The Ministry of Health and Welfare requires hygienic inspections for all imported raw/live fish and seafood if necessary. When compliance cannot be determined based upon the import notification documents and it is necessary to inspect the actual shipment, an “inspection order” is issued to the importer. This can occur if the shipment falls under the category of products which are likely to be in violation of the Law. The Inspection Order includes physical (organoleptic), chemical and bacteriological analysis.

Monitoring inspections may be carried out for other shipments. Food Sanitation Inspectors at the Airport Quarantine Stations inspect samples of fish and seafood selected randomly from a shipment. Inspectors check the appearance, odor, body temperatures, etcetera, for signs of deterioration. Monitoring inspection also includes other visual and organoleptic tests and determines chemical and bacteriological levels. If all samples are judged to be safe for human consumption, the MHW will release the shipment.

■ **Currently Designated Products Under “Inspection Order”**

Fish or Fishery Products	Lab Analysis Items
Puffer fish	Identification of species, tetrodotoxin
Aquacultured eel	Oxolinic acid
Aquacultured shrimp	Antibiotics, oxolinic acid
Aquacultured salmon	Antibiotics, oxolinic acid, sulfa drugs
Aquacultured puffer fish	Formaldehyde
Packed terrapin, tuna	CO
Arkshell	Color
Salmon roe, cod roe	NO <sub>2</sub>
Shellfish	PSP, DSP
Processed eel	Total plate count, coliforms
Raw Consumption Oyster	Bacteria count, most probable number of E coli, E coli 0157

■ **Natural Toxins/Pesticides/Heavy Metal/Industrial Contaminants etc. Tolerances**

Sales of fish harvested in polluted waters are restricted.

1) Natural Toxins

Paralytic Shellfish Poisoning (PSP): 4μ/g

Diarrhetic Shellfish Poisoning (DSP): 0.05μ/g

2) Pesticides

Dieldrin (Blue mussel): 0.1ppm

3) Heavy Metals

MHW set preliminary standards for mercury (in 1973) and PCBs (in 1972) in fish.

Mercury

Total mercury: 0.4 ppm

Methyl Mercury: 0.3 ppm

Fish found to be contaminated with mercury exceeding these standards must not be shipped to the market. However, tuna, swordfish, sailfish, bonito, skipjack, sablefish (gindara), rockfish, alfonsino (kinmedai), sharks, echubaigai and Tanner crab (benizuwaigai) are exempt. Fish and shellfishes from rivers of island water area (excluding those from lakes and marshes) are also exempt.

4) Industrial Contaminants

PCB: 0.5 ppm for edible portion of fish harvested offshore and from deep, distant waters.

3.0 ppm for edible portion of fish harvested in inland and in-shore waters.

5) Rot

It is prohibited to manufacture or process food for the purpose for sale that is rotten, decomposed or immature.

6) Food borne pathogens

Under Article 4 of the Law, there should be no contamination by pathogens.

7) Parasites

Under Article 4 of the Law, sales of fish and fishery products with parasites injurious to human health are prohibited.

■ **Product Manufacturing and Storage Standards**

**RE: The Japanese Food Sanitation Law**

The following summary is taken from the Japanese Food Sanitation Law.

Food in general:

- a) Product Standard: No antibiotic must be contained. Fish, shellfish and seafood must contain no antibiotic and chemically synthesized anti-bacterial with the exception of oxytetracycline which should not be greater than 0.1 ppm.
- b) Manufacturing Standard: Irradiation of food is prohibited with the exception of irradiation for the management of the manufacturing or processing process and that the absorption to the food is less than ten rad or specified otherwise for specific food items.

- c) Storage Standard: Total coliform group must be negative for non food ice or cooling agent which directly contact food for preservation. The use of antibiotic and irradiation for food preservation are prohibited.

■ **Oysters for Raw Consumption**

- a) Processing standards: Oysters for raw consumption must be harvested in waters that contain no more than 70 counts of total coliform per 100 ml of sea water. If harvested in other waters containing less than 70 counts of total coliform per 100 ml, oysters must be depurated with natural seawater or artificial salt water below 3% salinity. Water must be changed or sterilized consistently. Live oysters must be well washed immediately after being taken from water and before processing. Instruments used for shucking oysters must be well washed or sterilized. Containers for shucked oysters must be metal or synthetic products easy to clean and sterilize.

- b) Product standards: Fresh oysters for raw consumption:  
*E. coli* MPN: 230 counts or below per 100 grams.  
Total Plate Counts: 50,000 counts or below per one gram.

Storage temperature:  
Below 10° Centigrade for fresh oysters for raw consumption.

Use by date:  
Based on their scientific data, the Japanese Fisheries Association sets a four-day limit to sell shucked oysters for raw consumption from the date of shucking and a five-day period for shucked oysters for cooked consumption (shucking date is day one).

c) Manufacturing Standard: Oysters for raw consumption must be processed in a hygienic place and the use of synthetic additives (with the exception of hypochlorite) is prohibited.

d) Storage Standard: Unfrozen oysters must be stored at temperatures below ten degree Centigrade and frozen product must be stored at temperatures below minus 15° Centigrade. Oysters must be packaged in clean hygienic plastic film, aluminum foil or water proofed paper. Unfrozen raw consumption oysters may also be packaged in clean container with lid.

Fresh shucked oysters are normally put in plastic bags and cardboard or Styrofoam cartons for export to Japan. To improve the quality of the product, Japanese importers and wholesalers suggest the following procedures:

- 1) Purge shucked oysters in a 3% salt/water solution for at least three hours to completely remove oyster discharges.
- 2) Drain oysters well before packing in plastic bags and carton to meet ten kilo net oyster weight.
- 3) Put paper over the plastic bags containing oysters, then put gel packs over the paper to prevent freezing.
- 4) Avoid using plastic jars (these remind some buyers of medicine jars).

Contact:  
Veterinary Sanitation Division  
Environmental Health Bureau  
Ministry of Health and Welfare  
1-2-2, Kasugaseki,  
Chiyoda-ku, Tokyo Japan  
Tel: 81 3 3595 2337

#### ■ Japan Food Research Laboratories

The Japanese Food Research Laboratories (JFRL) can conduct specific product testing if required.



## **X. SPECIFIC SPECIES INFORMATION**

### **■ Importation of Shrimp/Prawns**

There are no import quotas for shrimp and prawns. However, it is necessary to go through import procedures based on the quarantine laws and the Food Sanitation Law.

Shrimp and prawn imported from cholera-infested regions must be inspected for cholera bacteria based on the quarantine laws. If bacteria are detected, importing is stopped and disinfection and other measures are taken. Importers must check with the World Health Organization (WHO) and quarantine offices to determine which areas are currently designated as cholera infected.

The current tariff rate for live, fresh and chilled shrimp and prawn is 4 %.

### **■ Importation and Handling of Flatfish**

There are several methods that have been suggested for improving the quality of flatfish, including:

- 1) Selecting fish before or in rigor mortis.
- 2) Avoid fish that have loose skin.
- 3) Avoid damaged fish especially on the blind (bottom) side.

Japanese importers pay a premium price for some species. Species in the family Paralichthyidae are often used as a substitute for Japanese "Hirame" and command a very high price. Species in the family Pleuronectidae are substituted as "Karei" and have a somewhat lower price. Ideally, to maintain quality, fresh flatfish should be killed quickly. This is often accomplished by breaking the spine and then bleeding by making a cut along the lateral line behind the pectoral fins and at the caudal peduncle. This process prolongs rigor mortis.

Fish should be cleaned and chilled to  $-3^{\circ}$  to  $0^{\circ}$  Centigrade prior to shipment. Packing in smaller cartons ( 8 kilos) can reduce compression and provide the best possible product. Generally fish are graded in 0.5 kilo increments.

### **■ Shipping and selling Tuna**

Fresh tuna is shipped to Japan for sale on the auction. Packing and shipping tuna is expensive. Therefore, it is critical for product to arrive in the best possible condition to command the best possible price. Shipping the fish as soon after harvest as possible may make a difference in the quality of the tuna and thus a difference in price.

Important points to check include for quality include:

- 1) Freshness.
- 2) Meat color should be bright red not dark.
- 3) Fat content.

Often the tail segment is cut off to check meat color and fat content. A special tool can be used to cut a core section of the fish to check these factors.

Tuna should be chilled thoroughly but not frozen. Pack ice around the body as well as inside the head and the belly. This should be done after the gills and guts are removed. Japanese fishermen do this on board to maximize the quality of their harvest. They also bleed the fish by cutting the tail and the blood vessels behind the neck and right behind the pectoral fins.

High quality tuna should be packed in individual wooden "coffins" to maximize quality. Often specially treated green paper is used to wrap the fish to preserve quality.

If fish are being sold on consignment, preliminary shipping information should be sent by fax to the auction house. Include the flight number and quantity and weight of the tuna being sent. After completion of the shipment, get a copy of the commercial invoice, packing list and also the air waybill number from the freight forwarder. Fax this information to the auction house as soon as possible, so that the auction house can arrange Customs clearance, trucking, etcetera, in Japan.

Auction results are available in about 24 to 36 hours. Payment should reach the exporter's bank account in a week or two. The auction results are reported to the exporter directly or through its agent. Auction results include the price for each fish, market conditions on the day of sale, total quantity of tuna sold, weather conditions, and so forth, as well as recommendations for improvement.

High quality tuna results in a very good price. If the first shipment brings a disappointing result, the exporter should be patient and follow any suggestions for improvement. It might even be possible for the auction company to send a technician for a short period of time to train fishermen and staff.

## **ADDITIONAL TOKYO, JAPAN CONTACTS**

Tokyo Customs House  
5-5-20 Konan Minato-ku  
Tokyo 108 Japan  
Tel: (81) 3 3472 7000

Customs Clearance System  
Tokyo Air Cargo Terminal Sub-branch Customs  
Tel: (81) 3 473 29 0605

Veterinary Sanitation Division  
Environmental Health Bureau  
Ministry of Health and Welfare  
1-2-2, Kasugaseki  
Chiyoda-ku, Tokyo Japan  
Tel: (81) 3 3595 2337  
Fax: (81) 3 3503 7964

Japan Food Research Laboratory Tokyo  
52-1 Yoyogichi, Shibuya-ku, Tokyo 151, Japan  
Tel: (81) 3 3469 7131  
Fax: (81) 3 3469 7009

### **Auction Houses:**

Tohto Suisan  
2-1, 5-chome  
Tsukiji, Chuo-ku, Tokyo 104, Japan  
Tel: (81) 3 3541 1803  
Fax: (81) 3 3541 5647

Daiichi Suisan  
Tel: (81) 3 3545 1345  
Fax: (81) 3 3541 1466

Chuo Gyorui  
Tel: (81) 3 3541 6071  
Fax: (81) 3 3545 5612

Daito Gyorui  
Tel: (81) 3 5565 8151  
Fax: (81) 3 3543 6611

Tsukiji Uoichiba  
Tel: (81) 3 3541 6130  
Fax: (81) 3 3543 4960

Japan Marine Products Importers Association  
Kamakurabashi Bldg.  
1-7-1 Uchikanda  
Chiyoda-ku, Tokyo 101, Japan  
Tel: (81) 3 5280 2891  
Fax: (81) 3 5280 2892



**UNITED STATES OF AMERICA  
LOS ANGELES, CALIFORNIA  
NEW YORK, NEW YORK**

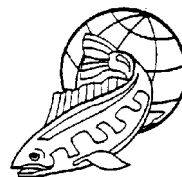

The United States of America is one of the most open economies in the world and a leading proponent of the General Agreement on Tariffs and Trade (GATT) goals. The United States is among the most developed and sophisticated financial environments in the world. There are thousands of national or federally chartered banks along with hundreds of foreign banks with operations in the United States. These banking networks provide many payment options for exporters to the United States.

The United States is the fourth largest country in the world. It is also a nation of many different cultures and regional diversities. The United States export market for fish and seafood products is large but federal government inspection standards are stringent.

## **II. GENERAL SHIPPING REGULATIONS**

■ **Language** English (national and commerce)

■ **Weights and Measures** Metric, Customary English/American

■ **Currency** United States Dollar (US\$)

■ **International Dialing Code** 1

■ **Public Holidays** The following are the official national holidays when banks, most federal and state offices and many businesses are closed. Often when a holiday falls on a Saturday or Sunday it will be observed the following Monday; Thanksgiving always falls on a Thursday, and few people work the next day turning the holiday into a four-day weekend. It is important to remember that work week in the United States is considered to be Monday through Friday.

New York's Day	January 1
Martin Luther King Day	January 15 (celebrated the third Monday of the month)
President's Day	Mid-February (celebrated the third Monday of the month)

Memorial Day	May 31 (celebrated the last Monday of the month)
Independence Day	July 4
Labor Day	September (the first Monday of the month)
Columbus Day	October 12
Veteran's Day	November 11
Thanksgiving Day	November (celebrated the last Thursday of the month)
Christmas Day	December 25

## ■ Commercial Shipments

(Please refer to the "Preparing the Shipment" chapter and glossary for the further explanation of terms)

1. Commercial Invoice.
  - a) Date of issue of the Invoice.
  - b) Name and address of the supplier.
  - c) Name and address of the importer.
  - d) Marks and number of packages.
  - e) Gross and net weight and measurements for each package.
  - f) Full description of the goods.
  - g) Total product value for Customs.
  
2. Shipper's Export Declaration.  
 The Shipper's Export Declaration is used to control exports and compile trade statistics and must be prepared and submitted to the Customs agent for shipments valued at more than \$ 2,500.
  
3. Labeling Requirements.
  - S Prepared in English, typewritten or in other non-erasable medium.
  - S Shipper's mark.
  - S Country of Origin.
  - S Weight marking (in pounds and kilograms).
  - S Number of packages and size of cases (in inches and centimeters).
  - S Handling Marks (international pictorial symbols).
  - S Cautionary markings.
  - S Port of Entry.
  - S Labels for perishable products.
  - S Legibility is extremely important.

## ■ Tariffs

Import duties for fish and seafood range from 3% to 15%. Check the Harmonized Tariff Schedule of the United States for species specific rates.

### ■ Certificate of Origin

A certificate of origin is not usually required unless specifically requested, it is tacitly assumed that the origin of the product is the exporting country.

## II. UNITED STATES FOOD AND DRUG ADMINISTRATION (FDA)

All imported fish and seafood products regulated by the Food and Drug Administration (FDA), Department of Health and Human Services must comply with the Federal Food, Drug and Cosmetic Act (FDCA) and sub-regulations.

The FDA mission is to enforce the FDCA which is designed to protect consumers' health, safety and pocketbook. These laws apply equally to domestic and imported products. The FDA regards fish and seafood as the most perishable of flesh foods. Many fish and seafood products have been detained at ports and entry points due to contamination. In addition, many products have been detained due to decomposition and filth. Sometimes preservatives or other additives, including drugs used for aquaculture, are used in fish and seafood products. Any additive used must be one recognized by the FDA as safe and must be declared on the label.

Chemical contamination from lakes, rivers and the oceans has been found to concentrate in certain species of fish and seafood. Excessive residues of pesticides, mercury, and other heavy metals are prohibited. Naturally occurring marine toxins also concentrate in some species, especially shellfish. Products adulterated with excessive levels of these toxins will be refused entry into the United States.

The FDA's mandatory Hazard Analysis and Critical Point (HACCP) program, implemented in December 1997, requires fish and seafood processors, re-packers and warehouses - both domestic and foreign exporters to the United States - to follow this modern food safety system thus further ensuring fish and seafood's safety.

The HACCP system focuses on identifying and preventing hazards that could cause food-borne illnesses rather than relying on spot-checks of manufacturing processes and random sampling of finished fish and seafood products to ensure safety.

All imported fish and seafood products are subject to examination by the FDA. Imported products are required to meet the same standards as domestic products. By definition, all imported products must be pure, wholesome, safe to eat, and produced under sanitary conditions. All products, when applicable, must contain informative and truthful labeling in English.



The FDCA prohibits the importation and distribution of products (including fish and seafood) that are adulterated and/or misbranded. As defined in the FDCA the term **adulteration** has to do with the content of a product (such as the addition of a substance which makes a product inferior, impure, not genuine, etcetera) while **misbranding** includes statements on labels or labeling that are false or misleading.

Additionally, if the foods offered for sale as consumer commodities, they must also comply with the requirements of the Fair Packaging and Labeling Act (FPLA). The FPLA requires additional labeling for consumer size packages ensuring that the labels provide consumers accurate information about the quantity of contents and other information facilitating value comparisons. The FDA advises the international fish and seafood industry that packaged product containing preservative(s) (such as sulfites, etcetera) artificial coloring or flavoring must bear labeling that declares prominently and conspicuously the presence of these substances. Without such labeling these products are misbranded.

If product will be offered for sale directly to consumers (for example, through grocery stores and club stores) the product must be labeled in accordance with the Nutritional Labeling and Educating Act (NLEA) of 1990. Please contact the FDA for further information.

#### ■ **FDA Analyses of Fish and Seafood Products**

Imported fish and seafood products are subject to inspection at the time of entry into the United States. FDA is generally notified of an importation by submission of the Importers Entry Notice (FDA-700 set) The acceptability of the food products is determined on the basis of their compliance with the FDCA, the FPLA, the NLEA and through the physical, chemical and/or bacteriological analyses. Analyses can be performed for food borne biological hazards such as filth, decomposition and/or microbiological contamination. Appropriate analysis can also detect adulteration with pesticides and/or industrial chemicals, natural poisons called marine biotoxins, illegal use of color or food additives and violations of the economic provisions of the FDCA.

#### ■ **FDA and EPA Guidance Levels for Fish and Seafood Products**

The following table contains the listing of published FDA and Environmental Protection Agency (EPA) tolerances, action levels and guidance levels relating to safety attributes of fish and seafood products. In many cases, these levels represent the point at, or above which, the FDA or EPA will take legal action to remove products from the market or confiscate at the port of entry. The levels contained in this table may not always be suitable for critical limits:

**Table 1 - FDA & EPA Guidance Levels**

Ready to eat fishery products (minimal cooking by consumer)	Enterotoxigenic <i>Escherichia coli</i> (ETEC) - 1 x 10 <sup>3</sup> ETC/g, LT or ST positive.
Ready to eat fishery products (minimal cooking by consumer)	<i>Listeria monocytogenes</i> - presence of organism.
All fish	<i>Salmonella</i> species - presence of organism.
All fish	1. <i>Staphylococcus aureus</i> - positive for staphylococcal enterotoxin, or 2. <i>Staphylococcus aureus</i> level is equal to or greater than 10 <sup>4</sup> /g (MPN).
Ready to eat fishery products (minimal cooking by consumer)	<i>Vibrio cholerae</i> - presence of toxigenic 01 on non-01.
Ready to eat fishery products (minimal cooking by consumer)	<i>Vibrio parahaemolyticus</i> - levels equal to or greater than 1 x 10 <sup>4</sup> /g (Kanagawa positive or negative).
Ready to eat fishery products (minimal cooking by consumer)	<i>Vibrio vulnificus</i> - presence of pathogenic organism.
All fish	<i>Clostridium botulinum</i> - 1. Presence of viable spores or vegetative cells in products that will support their growth, or 2. Presence of toxin.
Clams and oysters, fresh or frozen - imports	Microbiological - 1. <i>E.coli</i> - MPN of 230/100 grams (average of subs or 3 or more of 5 subs); 2. APC - 500,000/grams (average of subs or 3 or more of 5 subs).
Clams, oysters and mussels, fresh or frozen - domestic	Microbiological - 1. <i>E.coli</i> or fecal coliform - 1 or more of 5 subs exceeding MPN of 30/100 grams or 2 or more exceeding 230/100 grams; 2. APC - 1 or more of 5 subs exceeding 1,500,000/gram or 2 or more exceeding 500,000/grams.

Salt-cured, air dried uneviscerated fish	Not permitted in commerce (Note small fish exemption).
Tuna, mahi mahi, and related fish	Histamine - 500 ppm set based on toxicity. 50ppm set as defect action level, because histamine is generally not uniformly distributed in a decomposed fish. Therefore, 50 ppm is found in one section, there is the possibility that other units may exceed 500 ppm.
All fish	Polychlorinated Biphenyls (PCBs) - 2.0 ppm (edible portion)*.
Fin fish and shellfish	Aldrin and Dieldrin - 0.3 ppm (edible portion).
Frog legs	Benzene Hexachloride - 0.3 ppm (edible portion).
All fish	Chlordane - 0.3 ppm (edible portion).
All fish	Chlordecone - 0.4 ppm crabmeat and 0.3 ppm on other fish (edible portion).
All fish	DDT, TDE and DDE - 5.0 ppm (edible portion).
All fish	Heptachlor and heptachlor epoxide - 0.3 ppm (edible portion).
All fish	Mirex - 0.1 ppm (edible portion).
All fish	Diquat - 0.1 ppm*.
Fin fish and crayfish	Fluridone - 0.5 ppm*.
Fin fish	Glyphosate - 0.25ppm*.
Shellfish	Glyphosate - 3.0 ppm*.
Fin fish	Simazine - 12 ppm*.
All fish	2,4-D - 1.0 ppm*.
Salmonids, catfish and lobster	Oxytetracycline - 2.0 ppm.
All fish	Sulfamerazine - no residue permitted.
Salmonids and catfish	Sulfadimethoxine/ormetoprim combination - 0.1 ppm.
All fish	Unsanctioned drugs ** - no residue permitted.
Crustacea	Toxic elements: 76 ppm arsenic; 3ppm cadmium; 12 ppm chromium; 1.5 ppm lead; 70 ppm nickel.
Clams, oysters and mussels	Toxic elements: 86 ppm arsenic; 4 ppm cadmium; 13 ppm chromium; 1.7 ppm lead; 80 ppm nickel.
All fish	Methyl mercury - 1.0 ppm***.

All fish	Paralytic shellfish poison (PSP) - 0.8 ppm (80 $\mu$ g/100g) saxitoxin equivalent.
Clams, mussels and oysters, fresh, frozen or canned	Neurotoxic shellfish poison (NSP) - 0.8 ppm (20 mouse units/100 gram) brevetoxin- 2 equivalent.
All fish	Amnesic shellfish poison (ASP) - 20 ppm domoic acid, except in the viscera of Dungeness crab, where 30 ppm is permitted.
Molluscan shellfish	Diarrhetic shellfish poison - 0.2 ppm okadaic acid plus 35-methyl okadaic acid (DXT 1).
<p>* These values are tolerances.</p> <p>** Sanctioned drugs are approved drugs, low regulatory priority drugs and drugs used under an INAD. See the FDA Aquaculture Drugs Table.</p> <p>*** The FDA has listed methyl mercury as a potential safety hazard for bonito, halibut, Spanish mackerel, King mackerel, marlin, shark, swordfish and bluefin tuna. The selection of these species was based on historical data on levels of methyl mercury found in fish consumed in the United States</p> <p><i>Note:</i> The term “fish” refers to fresh or saltwater fin fish, crustaceans, other forms of aquatic animal life other than birds or mammals, and all mollusks, as defined in 21 CFR 123.3(d).</p>	

#### ■ Sulfite Residues

Fish and seafood products are among those foods to which sulfiting agents can be added to prevent discoloration. Sulfite residues are monitored by the FDA because these residues can cause allergic reactions in some asthmatic people and others who may be sulfite-sensitive. The FDA has determined that sulfite residues in the range of 60 to 100 ppm are in accordance with current good manufacturing practice in shrimp processing. Shrimp with edible portions exceeding the 100 ppm levels will be considered adulterated.

The compliance for sulfite residues levels for other fish and seafood products will be evaluated case by case.

#### ■ FDA Aquaculture Drugs

The FDA believes that unregulated drug use in aquacultured fish and seafood holding pounds poses a potential human health hazard. These substances may be carcinogenic and/or may cause antibiotic resistance in humans. To control this hazard in food animals, all drugs, whether for direct medication or for the addition to feed, must be approved by the FDA. Under certain conditions authorized by FDA, unapproved new animal drugs may be used in conformance with the terms of an Investigational New Animal Drug (INAD) application.

Incentives for the use of animal drugs in aquatic animal species include the need to: 1) treat and prevent diseases; 2) control parasites; 3) affect reproduction and growth; and, 4) tranquilization (for example, during times of transit). Relatively few drugs have been approved for aquaculture use. As a result, aquaculturists may not use unapproved drugs, general purpose chemicals that are not labeled for drug use, and approved drugs in a manner that deviates from the labeled instructions.

Labels of approved drugs list mandatory withdrawal times, where applicable. These withdrawal times must be observed to ensure that the edible tissue is safe when it is offered for sale. Tissue residue tolerances have been established for some drugs.

**1. FDA approved aquaculture drugs**

FDA approved aquaculture drugs with their species and withdrawal times are listed below. Additional details on approved drug manufacturers, conditions of use (for example, disease conditions and dosage levels) can be obtained from the FDA, Center for Veterinary Medicine; or the “Guide to Drug, Vaccine and Pesticide Use in Aquacultural Extension Service,” Publication B-5085. The approved manufacturers can also be found on the FDA Internet site: <http://vm.cfsan.dfa.gov/~dms/haccp-2k.html>.

In the case of non-United States grown product, please contact the FDA to determine the drugs that can be used on products destined for export to the United States.

- ! **Formalin Solution**, may only be used in salmon, trout, catfish, largemouth bass, and bluegill for the treatment of protozoa and for control of fungi of the family Saprolegniaceae on the eggs of salmon, trout and pike (esocids), and for the control of external protozoan parasites on shrimp.
- ! **Tricaine methane sulfonate (MS-22)**, may be used in the families Ictaluridae (catfish), Salmonidae (salmon and trout), and Esocidae (pike), and Percidae (perch). It may not be used within 21 days of harvest. In other fish and cold-blooded animals the drug should be limited to use in hatcheries or laboratories.
- ! **Oxytetracycline**, for feed use, may only be used in salmonids, catfish and lobster. Withdrawal times are: pacific salmon, 7 days; other salmonids, 21 days; catfish, 21 days; lobster, 30 days. Oxytetracycline tolerance in the flesh is 2.0 ppm.
- ! **Sulfamerazine**, may only be used in trout. It may not be used within 21 days of harvest. Sulfamerazine tolerance in the flesh is zero. *Note:* this product is not currently marketed in the United States.

- ! **Sulfadimethoxine/ormetoprim combination**, may only be used in salmonids and catfish. Withdrawal times are: salmonids, 42 days, catfish, 3 days. Sulfadimethoxine/ormetoprim combination tolerance in the flesh is 0.1 ppm for both drugs.
  
- ! **FDA low regulatory priority aquaculture drugs**  
 FDA's Center for Veterinary Medicine identified the following number of "low regulatory priority aquaculture drugs." The following list identifies these compounds and provides their indicated use and usage levels. These compounds have undergone review by the FDA and have been determined to be new animal drugs for low regulatory priority. Additional information on this subject can be obtained from: the FDA Center of Veterinary Medicine; or "Guide to Drug, Vaccine and Pesticide Use in Aquaculture," Texas Agriculture Extension Service, Publication B-5085.
  
- ! **Acetic Acid**, used in a 100 to 200 ppm dip for 1 to 10 minutes as a parasite remover for fish.
  
- ! **Calcium Chloride**, used to increase water calcium concentration to insure proper egg hardening. Dosages used would be that necessary to raise calcium concentration to 1 - 20 ppm CaCO<sub>3</sub>. Used up to 150 ppm indefinitely to increase the hardness of water for holding and transporting fish in order to enable fish to maintain osmotic balance.
  
- ! **Calcium Oxide**, used as an external protozoacide for fingerlings to adult fish at a concentration of 2000 mg/L for 5 seconds.
  
- ! **Carbon Dioxide Gas**, used for anesthetic purposes in cold, cool, and warm water fish.
  
- ! **Fuller's Earth**, used to reduce the adhesiveness of fish eggs to improve hatchability.
  
- ! **Garlic (whole form)**, used for control of helminth and sea lice infestations of marine salmonids at all life stages.
  
- ! **Hydrogen Peroxide**, used at 250-500 mg/L to control fungi on all species and life stages of fish, including eggs.
  
- ! **Ice**, used to reduce metabolic rate of fish during transport.
  
- ! **Magnesium Sulfate**, used to treat external monogenic trematode infestations and external crustacean infestations in fish at all life stages. Used in all freshwater

species. Fish are immersed in a 30,000mg Mg So<sub>4</sub> solutions for 5 to 20 minutes.

**Onion (whole form)**, used to treat external crustacean parasites, and to deter sea

! **Papaia**

masses in order to improve hatchability and decrease the incidence of disease.

!

, used as an aid in osmoregulation; relieves stress and prevents shock. Dosages used would be those necessary to increase in

! **Povidone Iodine**

disinfectant during and after water hardening.

! **Sodium Bicarbonate**

introducing carbon dioxide into the water to anesthetize fish.

!

**Sodium Chloride**, used in a 0.5% to 1.0% solution for an indefinite period as an osmoregulatory aid for the relief of stress and prevention of shock; and 3% solution for 10 to 30 minutes as a parasite remover,

!

, used in a 15% solution for 5 to 8 minutes to treat eggs in order to improve their hatchability.

**Urea & Tannic Acid**, used to denature the adhesive component fish eggs at

minutes, followed by separate solution of 0.75g tannic acid/5 liters of water for an additional 6 minutes. These amounts will treat approximately 400,000 eggs.

following conditions are met; 1) the substances are used for the stated purposes; 2) the substances are used at the prescribed levels; 3) the substances are used according to good

and 5) there is not likely to be an adverse effect on the environment (United States).

## ▣ Food Additives

components of food, either directly or indirectly, or which may otherwise affect the characteristics of the food. The term specifically includes any substance intended for use

of the food, and any source of radiation intended for any such use.

But the law excludes from the definition of a “food additive”:

1. Substances generally recognized as safe (GRAS) by qualified experts.
2. Substances used in accordance with a previous approval (“prior sanction”) under either the Federal FDCA, the Poultry Products Act or the Federal Meat Inspection Act.
3. Pesticide chemicals in or on raw agricultural products.
4. Color additives.
5. New animal drugs.

Please note that pesticide chemicals, color additives, and new animal drugs are subject to similar safety requirements of other sections of the law.

Importers not certain whether chemicals or other ingredients used in their products are subject to the safety clearance requirements of the Federal FDCA may seek an opinion from the FDA. In addition see Sections on approved Aquaculture Drugs and Color Additives and Table 1 - FDA & EPA Guidance Levels.

#### ■ Color Additives

The FDCA provides that foods, drugs, cosmetics and some medical devices are adulterated if they contain color additives that have not proved safe to the satisfaction of the FDA for the particular use. A color additive is a dye, pigment or other substance, whether synthetic or derived from a vegetable, animal, mineral or other source, which imparts a color when added to a food, drug, cosmetic or the human body.

Contact the FDA to determine which color additives are prohibited for use in live and fresh fish and seafood: Food and Drug Administration, Office of Cosmetics and Colors (HFS-105), 200 C Street, S W, Washington, D.C. 20204, United States.

#### ■ FDA Temperature Recommendations

Fresh fish and seafood is highly perishable. The qualifier “fresh” on the label only applies to unprocessed products. The FDA recommends that a proper refrigeration temperature be maintained at all times as close as possible to the temperature of ice (0°C). The proper temperature should be ensured from time of harvest and during subsequent storage, processing and throughout all distribution channels(s). Vacuum-packaged product must be refrigerated at all times.

#### ■ FDA Seafood List

##### **Re: Acceptable common names for fish and seafood products**

To prevent substitution of one kind of fish and seafood product for another, the consequent deception of the consumer, it is essential that labels bear names which accurately identify the products designated. Words like “fish,” “shellfish,” “seafood” and “mollusc” are not sufficient; the name of the specific product must be used. Many fish, crustaceans and molluscs have well-established common or usual names throughout the United States. These may not be replaced with other names, even though the other names may be used in some areas or countries. These may not be replaced with coined names,



even though the coined names may be considered more attractive or to have greater sales appeal.

A more difficult problem is deciding what constitutes the proper designation for fish and seafood which has not previously been marketed in the United States, and thus which has not acquired an established common or usual name in the United States. In selecting an appropriate name for such a product, full consideration must be given to its proper biological classification, and to avoiding a designation which duplicates or may be confused with the common name or usual name, in this country, of some other species.

Fish and seafood products must be identified with a common or market name that is acceptable in the United States. Refer to the FDA publication entitled “The Seafood List” which specifies the acceptable market or common names for finfish and invertebrates (mollusks and crustaceans) species. If the species is not listed, the FDA recommends that the importer submit for FDA review of the scientific name (genus and species) and the proposed common name or market name. It is advisable to use either the Acceptable Market Name or Common Name in labeling fish and seafood which will help assure that labeling of the product will comply with FDA and National Marine Fisheries Service (NMFS) regulations. **Use of the vernacular name is not encouraged, and may cause the fish and seafood to be considered misbranded.**

“The Seafood List” was developed by the FDA, in cooperation with the NMFS. The print version of “The Seafood List” may be purchased. To order, contact:

United States Government Printing Office  
Superintendent of Documents, Mail Stop SSOP  
Washington, D.C. 20402-9328 United States  
Ask for Reference Number: ISBN 0-16-042999-4  
Tel: (202) 783 3238

“The Seafood List” can also be viewed on the FDA Internet site:  
<<http://vm.cfsan.fda.gov/~frf/seaintro.html>> .

#### ■ **FDA Import Procedures** < [www.fda.gov](http://www.fda.gov)>

##### **Re: Fish and Seafood**

To ensure that the FDA is notified of all regulated products imported into the United States, the importer or the importer’s representative, **must file an entry notice and acquire a bond to cover the imported goods for release with the United States Customs Service.** FDA is notified by Customs of the entry and makes a decision as to the article’s admissibility. The procedure is outlined below:

1. Importer or agent files entry documents with United States Customs Service within five working days of the date of arrival of a shipment at a port of entry.

2. FDA is notified of an entry or a regulated food through:
  - S Duplicate copies of Customs Entry Documents (CF 3461, CF 3461 ALT, CF 7501 or alternative).
  - S Copy of commercial invoice.
  - S Surety to cover potential duties, taxes and penalties.
  
3. FDA reviews Importer's Entry Documents to determine if a physical examination, port examination, sample examination should be made.
  
- 4A. Decision is made not to collect a sample. FDA sends a "May Proceed Notice" to United States Customs and the importer of record. The shipment is released as far as FDA is concerned.
  
- 4B. Decision is made to collect a sample based on:
  - S Nature of the product.
  - S FDA priorities.
  - S Past history of the commodity.

FDA sends a "Notice of Sampling" to United States Customs and the importer of record. The shipment must be held intact pending further notice. A sample is collected from the shipment. The importer of record may move the shipment from the airport to another port or warehouse (see United States Customs section for more details).
  
5. FDA obtains a physical sample. The sample is sent to an FDA District Laboratory for analysis.
  
- 6A. FDA analysis finds the sample in compliance with requirements. FDA sends a Release Notice to United States Customs and the importer of record.
  
- 6B. FDA analysis determines that the sample "appears to be in violation of the Food, Drug and Cosmetic Act and other Acts." FDA sends United States Customs and the importer a record a Notice of Detention and Hearing which:
  - S Specifies the nature of violation(s).
  - S Gives the importer of record 10 working days to introduce testimony as to the admissibility of the shipment.

The hearing is the importer's only opportunity to present a defense of the importation and/or to present evidence as to how the shipment may be made eligible for entry.

- 7A. Consignee, true owner, importer of record, or a designated representative responds to the Notice of Detention and Hearing. The response permits the introduction of testimony either verbal or written, as to the admissibility of the shipment.
- 7B. Consignee, true owner, importer of record, or a designated representative neither responds to the Notice of Detention and Hearing nor requests an extension of the hearing period.
- 8A. FDA conducts a hearing concerning the admissibility of the product. The hearing is an opportunity to present relevant matters and is confined to the submission of pertinent evidence.
- 8B. FDA issues a Notice of Refusal of Admission to the importer of record. This is the same person or firm who was sent a Notice of Sampling and the Notice of Detention and Hearing are sent a copy of the Notice of Refusal.
- 9A. Importer of record presents evidence indicating that the product is in laboratory and which are within the published guidelines for levels of contaminants and defects in food for human use, may be presented.  
  
Importer of record submits an Application for Authorization to Recondition or to Perform Other Action (FDA Form FD 766). The form into compliance by relabeling or other action, or by converting to a non-food use. A detailed method to bring the food into compliance must be
- 10A. FDA collects a follow-up sample to determine compliance with guidelines.  
  
FDA evaluates the reconditioning procedure proposed by the importer. A bond is required for payment of liquidated damages.  
  
FDA finds that the sample is "in compliance." A Release Notice with the statement "Originally Detained and Now Released" is sent to United States

- 11B. FDA finds that the sample is not in compliance. The importer may either submit an Application for Authorization to Recondition or to Perform Other Action (see 9B), or, FDA will issue a Notice of Refusal of Admission (see 8B).
- 11C. FDA approves importer's reconditioning procedures. The approved application contains the statement "Merchandise Should be Held Intact Pending the Receipt of FDA's Release Notice".
- 11D. FDA disapproves applicant's reconditioning procedure if past experience shows that the proposed method will not succeed. A second and final request will not be considered unless it contains meaningful changes in the reconditioning operation to ensure a reasonable change of success. The applicant is informed on FDA Form FD 766.
- 12. Importer completes all reconditioning procedures and advises FDA that the goods are ready for inspection/sample collection.
- 13. FDA conducts follow-up inspection/sample collection to determine compliance with the terms of the reconditioning authorization.
- 14A. FDA analysis finds that the sample is in compliance. A Release Notice is sent to the importer and to United States Customs. The charges for FDA supervision are assessed on FDA Form FD 790. Copies are sent to United States Customs which is responsible for obtaining total payment including any expenses incurred by their personnel.
- 14B. FDA analysis finds that the sample is still not in compliance. Charges for the FDA supervision are assessed on FDA Form FD 790. Copies are sent to United States Customs which is responsible for obtaining total payment including expenses incurred by their personnel.

**■ FDA Tips for Fish and Seafood Importers**

The following tips from the FDA can help importers clear fish and seafood entries:

- S** Determine before shipment that the product to be imported is legal.
- S** Have private laboratories examine samples of foods to be imported and certify the analysis of the processor. While not conclusive, these analyses might serve as an indication of the processor's ability to produce acceptable, legal products.
- S** Become acquainted with FDA's legal requirements, before contracting for a shipment.

S

entry.

S



Fresh and fresh-frozen oysters, clams and mussels for importation into the United States are subject to rejection unless from countries that participate in the National Shellfish

Republic of Korea, Chile, Mexico, Australia and New Zealand now have active programs and agreements with the FDA. For further information on the requirements of the National

Branch (HFS-400), 200 C Street SW, Washington, D. C. 20204, United States.

### ■ Shellfish Certification

FDCA and also with requirements of the individual State health agencies cooperating in the National Shellfish Sanitation Program (NSSP) administered by the FDA in cooperation

Because raw molluscan shellfish (clams, mussels and oysters) may transmit diseases such as typhoid fever, or be carriers of natural or chemical toxins, it is critical that they be obtained

Shellfish harvesting is prohibited in areas contaminated by sewage or industrial wastes. To enforce this prohibition, these areas are patrolled and warning signs are posted by State

harvested from approved growing areas and that shellfish shippers and exporters meet NSSP requirements before certifying the plant to FDA for listing in the Interstate Shellfish

information and use of food control officials, fish and seafood industry and other interested persons. The publication is distributed under the authorities of the Public Health Service

The “Interstate Certified Shellfish Shippers List” contains shippers that have been certified

For further information contact:

Director of Program & Enforcement Branch

200 C Street, SW

Washington, D.C. 20204 United States

Fax: (1) (202) 418.3198

<<http://vm.cfsan.fda.gov/~ear/shellfis.html>>

Shellfish plants certified by the State Shellfish Sanitation Control Authority (SSCA) are required to place their certification number on each container or package of shellfish shipped. The number indicates that the shipper is under State inspection, and that it meets the applicable state requirements. It also serves the important purpose of identifying and tracing shipments found to be contaminated or involved in disease outbreaks. Shippers are also required to keep records showing origin and disposition of all shellfish handled and to make these records available

#### ■ **FDA Import Alerts**

The purpose of Import Alerts is to identify and disseminate import information (problems, violative trends, etc.) to FDA personnel thus providing for more uniform and effective import coverage. Import Alerts identify products and shippers that have met the criteria for automatic detentions. Information on automatic detentions, import alerts or import bulletins policy contact the FDA, Division of Import Operations and Policy (DIOP), HFC-170, 5600 Fisher Lane, Rockville, MD 20857, United States.

The most recent Import Alerts for fish and seafood can be found on the FDA Internet site at:<[http://www.fda.gov/ora/fiars/ora\\_import\\_list\\_16.html](http://www.fda.gov/ora/fiars/ora_import_list_16.html)>.

#### ■ **FDA Computerization**

FDA assures the expeditious handling of imported products through the automation of its import operations. By combining the FDA Operational and Administrative system for Import Support (OASIS) and the United States Customs Service Automated Commercial System (ACS), the FDA reviewer is able to more efficiently evaluate and process each import entry.

The import filer transmits the required shipment-specific FDA data into ACS. Within minutes, that individual receives notification that either their shipment has been released or FDA wishes to review it. This system provides FDA with immediate data on products imported, provides information on potential problems and maintains national historic data files to develop profiles on specific products, shippers and manufacturers. Eventually all filers processing entries through the United States Custom's ACS will provide FDA information electronically.

#### ■ **FDA Certificates of Export**

The certificate of Export will generally indicate that the products are regulated by the FDA and that they are not at this time the subject of any enforcement action by the FDA. Such certificates are not guarantees nor a certification of the product's safety and quality. They are issued at the request of a domestic (United States) company.

### **FDA required provisions for issuing Certificate:**

810(e) of the Federal Food, Drug and Cosmetics Act as follows:

- 1.
2. Is not in conflict with the laws of the country to which it is intended
3. Is labeled on the outside of the shipping package that is intended for
4. The particular shipment is not sold or offered for sale in domestic

### **Requesting a Certificate:**

Each request by the exporter should be accompanied by:

An original label or, if no labels have been printed, a detailed draft version of the current label.

Sufficient information for each product for which a certificate is requested so the reviewer can properly identify the product.

Adequate identification of the actual manufacturer of each product.

4. *“The requester hereby presents and acknowledges that the company is aware that in making this request the company is subject to the Codes which makes it a criminal offense to knowingly and willfully make a false and fraudulent statement or to make or use a false agency of the United States or to knowingly and willfully falsify, conceal, or cover up any trick, scheme or device a material fact in United States”.*

### **Where to write for a Certificate:**

seafood:

**Office of Seafood, HFS-400**

Center of Food Safety and Applied Nutrition  
200 C Street, S.W.

It will take approximately four to six weeks to respond to certificate requests. There is a charge of \$10.00 per certificate.

#### ■ FDA Airport (region) Contacts

1. FDA - Los Angeles Resident Post  
1990 Mac Arthur Blvd.  
Suite 300  
Irvine, CA 92715 United States  
Import Operations:  
Tel: (1) (714) 252 7714
2. FDA - John F. Kennedy Airport Resident Post  
Halmar Bldg. 75  
Room 245  
Jamaica, New York 11430-1705 United States  
Tel: (1) (718) 553 1652  
Fax: (1) (718) 553 0472

#### ■ HACCP Program

The FDA/Office of Seafood has issued a “Seafood HACCP Regulations/Special Requirements for Imported Fish and Seafood Products/A Guide for Importers and Foreign Processors - Questions & Answers.” This document is intended for guidance only, to facilitate compliance with the new regulations. Questions that importers and foreign processors have concerning the interpretation of the requirements of the Seafood HACCP Regulations (21 CFR 123) should be submitted to the Food and Drug Administration, Office of Seafood (HFS - 417), 200 C Street, Washington, D.C. 20204, United States (FAX: (1) (202) 418-3196).

### III. UNITED STATES CUSTOMS SERVICE

The major responsibility of the United States Customs Service is to administer the Tariff Act of 1930, as amended. Primary duties include the assessment and collection of all duties, taxes and fees on imported merchandise, which includes live and fresh fish and seafood and the enforcement of Customs and related laws. As a major enforcement organization, the Customs service combats smuggling and fraud on the revenue and enforces the regulations of numerous other Federal agencies at ports of entry along the borders of the United States.

#### ■ Suggestions to Exporters for easier United States Customs Clearance

1. Include all information required on the Customs invoice.
2. Prepare invoices carefully. Type them clearly. Allow sufficient space between lines. Keep the data within each column.
3. Make sure that the invoices contain the information that would be shown on a well-prepared packing list.
4. Mark and number each package so that it can be identified with the corresponding marks and numbers appearing on the invoice.



5. Show on the invoice a detailed description of each item of goods contained in each
6. Mark the goods legibly and conspicuously with the name of the country of origin of the United States.
7. apply to your goods, such as the FDA laws relating to fish and seafood imports.
8. labeling etcetera, sent by the United States buyer. The buyers have probably made a careful check of the requirements which will have to be met with the product
9. Work with the United States Customs in developing packing standards for
10. the goods for shipment, do not allow narcotics smugglers the opportunity to
- 11.
12. that participates in the Automated Broker Interface (ABI).

purchaser or licensed Customs broker designated by the owner, purchaser or consignee)

Imported fish and seafood products are not legally entered until after the shipment has

Customs and the FDA and estimated duties have been paid. It is the responsibility of the

### ■ **Marking: Country of Origin**

a conspicuous place as legibly, indelibly and permanently as the nature of the article

purchaser in the United States the name of the country in which the article was

Live fish and seafood are exempted from being individually marked by Section 304 of the

of fresh fish and seafood packed in wholesale containers are also exempted from marking

Containers that contain live fish and seafood must be marked with the name of country of

constructed so that they can be readily opened for inspection of the contents.

## ■ United States Customs Seizures and Forfeitures

United States Customs seizes merchandise that an importer attempts to import in violation of United States law on behalf of more than 40 agencies of the United States Government. For live fish and seafood products these would include, but not be limited to, the Food & Drug Administration (FDA), the Department of Commerce, National Marine Fisheries Service (NMFS) and the Department of the Interior, United States Fish & Wildlife Service (USF&WS) for whom Customs acts as enforcement arm at the ports of entry, United States borders and mail locations.

Some merchandise seized is prohibited and some is merely restricted. Some merchandise is seized due to violation of entry requirements (failure to declare, false valuation to reduce duty, etcetera). Some is seized to secure payment of a penalty.

All seizures, forfeitures, mitigation and property dispositions are strictly governed by laws designed to afford the greatest possible due process.

- c. **Seizure Notice:** The importer is provided with a “Notice of Seizure,” listing the items seized, the law(s) violated. The violators’ options (rights and time to petition, elect judicial or administrative processing, etcetera,) and the Customs contact location and telephone number. The seizing officers also look for information on other possible claimants to the property. Customs sends identical seizures notices to all other persons with a valid interest in the property, who have the same rights as the violator.
  
- b. **Adjudication:** The Fines, Penalties & Forfeitures Officer (FPFO) for the Customs service port takes custody of the property and assigns the case to a specialist. If the importer files a petition for administrative relief, the mitigating facts and circumstances the importer provides, together with the report and findings of the seizing and investigating officers, are evaluated and weighed by the specialist. The specialist makes a recommendation to: forfeit some or all of the property to the Government; remit some or all of the property to the violator or claimant; remit the property and issue a penalty; release the property for immediate re-exportation; or return some or all of the property upon of a sum of money based on the property’s value in lieu of forfeiture. In this last type of resolution, the money paid is then forfeited to the Government.

**c. Forfeiture Notice:**

violator/claimant fails to petition or comply with the FPFO decision within the specified time. Forfeiture proceedings consist of public announcement,

with additional notice and time in which to make claims on the property. Intent to forfeit low-value merchandise is posted in the Customhouse of the

higher-value merchandise in a newspaper of general circulation in the appropriate area on three successive occasions, seven days apart. A

the forfeiture proceedings by contacting Customs. If the petition is accepted but fails again, Customs must re-institute forfeiture proceedings (the

property is transferred to the government.

Depending on the character of the forfeited property, it may be destroyed, shared with



Customs Management Centers (CMCs) ensure that Customs delivers high-quality, uniform service within their geographic area by serving as a single management level between the

the execution of the core business processes--trade compliance, passenger and outbound.

They also coordinate with counterpart Special Agent-In-Charge (SAC) offices in executing

Note: Please direct questions to the port - including Service Ports, Area Ports and Ports of Entry - at the locations indicated in Section rather than the CMCs concerning:

Release, Classification and Valuation of Imported Merchandise.

!

! Payment of Duties.

Fines, Penalties and Forfeiture.

!

! Other Activities Engaging the Trade Community.

**1. United States Customs Management Center**

P.O. Box 32639

Long Beach, CA 90815 United States

Contact: John Heinrich  
Tel: (1) (562) 980 3100  
Fax: (1) (562) 980 3107

2. **United States Customs Management Center**  
6 World Trade Center  
Room 716  
New York, NY 10048 United States  
Contact: Anthony Liberta  
Tel: (1) (212) 466 4444  
Fax: (1) (212) 466 2097

#### ■ **United States Customs Bonded Warehouses**

A United States customs-bonded warehouse is a building or other secured area in which dutiable goods may be stored, manipulated, or undergo manufacturing operations without payment of duty.

Upon entry of goods into the warehouse, the importer and warehouse proprietor incur liability under a bond. This liability is canceled when the goods are one of the following:

- Exported.
- Withdrawn for supplies to a vessel or aircraft in international traffic.
- Destroyed under Customs supervision.
- Withdrawn for consumption within the United States after payment of duty.

#### **Types of Customs bonded warehouses:**

The following are the classes of authorized Customs bonded warehouses that may be applicable to the holding of live and fresh fish and seafood:

1. Premises owned or leased by the United States Government and used for the storage of merchandise that is undergoing Customs examination, is under seizure, or is pending final release from the Customs custody. Unclaimed merchandise stored in such premises will be held under “general order.” When such premises are not sufficient or available for the storage of seized or unclaimed goods, such goods may be stored in a warehouse of Class 3 and 4.
2. Importers’ private bonded warehouses used exclusively for the storage of merchandise belonging or consigned to the proprietor thereof. A Class 4 or 5 warehouse may be bonded exclusively for the storage of goods imported by the proprietor thereof, in which case it should be known as a private bonded warehouse.

3. Public bonded warehouse used exclusively for the storage of imported
4. Bonded yards or sheds for the storage of heavy and bulky imported enclosures for the storage of imported animals (live products); and tanks for storage of imported liquid merchandise in bulk.  
  
Bonded warehouses established for the cleaning, sorting, re-packing or otherwise changing the condition of, but not the manufacturing of, imported proprietor.
6. conditionally duty-free merchandise for use outside the Customs territory. Merchandise in this class must be owned or sold by the proprietor and exportation by, or on behalf of, individuals departing from the Customs territory for foreign destinations.

**Advantages of using a bonded warehouse:**

No duty is collected until merchandise is withdrawn for consumption. An importer, merchandise from the bonded warehouse. If no domestic buyer is found for the imported articles, the importer can sell merchandise for export, thereby canceling

Many items subject to quota or other restrictions may be stored in a bonded warehouse. Check with the Customs office to ascertain if live and fresh fish and

In addition to the United States Customs Service, fish and seafood importers should contact the other agencies ( the Food & Drug Administration, the United States regarding products arise.

Goods may be entered for consumption, entered for warehouse at the port of there under the same conditions as the port of arrival.

■ **United States Customs Contacts:**

**Los Angeles CA:**

United States Customs Service

11099 S. La Cienega Blvd  
Los Angeles, CA 90045 United States  
Port Director: Thomas Winkowski  
Tel: (1) (310) 215 2618  
Fax: (1) (310) 215 2013  
Hours of Operation: 08:00 - 16:30  
Special Arrangements can be made for off hours inspection

Special Agent-In-Charge  
United States Customs Service  
300 South Ferry Street  
Room 2037  
Terminal Island, CA 90731 United States  
Tel: (1) (310) 514 6231  
Fax: (1) (310) 514 6280

**2. New York, New York**

United States Customs Service  
New York/JFK Area (Service Port)  
Bldg. # 77  
Jamaica, New York 11430 United States  
Port Director: John Martuge  
Tel: (1) (718) 553 1542  
Fax: (1) (718) 553 0077  
Hours of Operation: 08:00 - 16:30  
Special Arrangements can be made for off hours inspection

Special Agent-In-Charge  
United States Customs Service  
6 World Trade Center  
Room 714  
New York, NY 10048 United States  
Tel:(1) (212) 466 2900  
Fax: (1) (212) 466 2903

For more United States Customs contacts at John F. Kennedy Airport in New York, access the following Internet site: <<http://www.jfkcargo.com/jfkcustom.htm>>

**■ Commercial Invoice**

A commercial invoice, signed by the seller or shipper, or agent, is acceptable for Customs purposes if it is prepared in accordance with Section 141.86, Customs Regulations, and in the manner customary for a commercial transaction involving goods of the kind covered by

the invoice. Importers and brokers participating in the Automated Broker Interface may eliminate the paper document.

The commercial invoice must provide the following information, as required by the “Tariff

**S** The port of entry to which the merchandise is designated.

If merchandise is sold or agreed to be sold, the time, place and names of buyer and seller, if consigned, the time and origin of shipment and names of

**S** A detailed description of the merchandise, including the name by which each common names), the grade or quality, and the marks, numbers and symbols under which it is sold by the seller or manufacturer to the trade in the packages in which the merchandise is packed.

**S**

**S** If sold or agreed to be sold, the purchase of each item in the currency of the

**S** If the merchandise is shipped for consignment, the value for each item, in such value, the price in such currency that the manufacturer, seller, shipper, or owner would have received, or was willing to receive, for such wholesale quantities in the country of exportation.

**S**

**S** All charges upon the merchandise, itemized by name and amount including parking; and if not included above, all charges, costs, and expenses incurred in bringing the merchandise from alongside the carrier at the first United freight to the port of exportation need not be itemized by amount included in the invoice price and so identified. Where the required information does invoice.

- S All rebates, drawbacks and bounties, separately itemized, allowed upon the exportation of the merchandise.
- S The country of origin.
- S All goods or services furnished for the production of the merchandise not included in the invoice price.

If the merchandise on the documents is sold while in transit, the original invoice reflecting this transaction and the resale invoice or a statement of sale showing the price paid for each item by the purchaser will be filed as part of the entry, entry summary, or withdrawal documentation.

The invoice and all attachments must be in the English language, or will be accompanied by an accurate English translation.

Each invoice should state in adequate detail what merchandise is contained in each individual package.

If the invoice or entry does not disclose the weight, gauge, or measure of the merchandise necessary to ascertain duties, the importer of record will pay expenses incurred to obtain this information prior to the release of the merchandise from Customs custody.

Each invoice should include in detail, for each class or kind of merchandise, every discount from list or other base price which has been or may be allowed in fixing each purchaser price or value.

When more than one invoice is included in the same entry, each invoice with its attachments will be numbered consecutively by the importer on the bottom of the face of each page, beginning with number one.

#### ■ Foreign Trade Zones

Foreign Trade Zones are areas designated in the United States by the United States Customs Service to hold or otherwise manipulate goods for an unlimited period of time awaiting a favorable market in the United States or nearby countries without being subject to Customs entry, payment of duty, tax or bond. These areas are considered outside the customs territory of the United States for Customs importing procedures. The location of an establishment in a foreign trade zone has absolutely no bearing on the jurisdiction of the FDA or the applicability of the laws it administers. Foreign Trade Zones are part of the United States and the movement of regulated products into or out of such zones, including export, constitutes interstate commerce. Therefore, regulated products in foreign trade zones must comply with those laws that come under the purview of the FDA and the United States Customs.



## **IV. United States DEPARTMENT OF COMMERCE**

### **National Marine Fisheries Service (NMFS)**

Many governments require imported fish and seafood entering the country be accompanied by an inspection (health/sanitary) certificate. Essentially this certifies that the product meets certain standards imposed by the importing country ( for example, permissible level of mercury, bacterial count, level of chemical contaminants, and so forth.) The National Marine Fisheries Service (NMFS) of the United States Department of Commerce is the only federally authorized agency which conducts inspection and analysis of fishery commodities for export. The agency issues a United States Government Certificate attesting to the inspection and analysis findings. Determination of compliance of products being exported to foreign countries can also be certified.

- Origin and species of fish.
- Sanitary condition of processing facilities.
- Product inspection for wholesomeness, safety and suitability for human consumption.
- Chemical, biological and physical tests for adulterants, contaminants and microconstituents.

Import requirements for fish and seafood products tend to change frequently. Check with the buyer or the local consulate to determine what type of inspection certification is needed.

To request inspection services, complete form NOAA 89-814 and fax it to the appropriate inspection office. Or call for further information:

#### **1. Los Angeles Area**

Los Angeles Lot Inspection Office  
National Marine Fisheries Service  
5600 Rickenbacher Road, Bldg 7  
Bell, CA 90201 United States  
Tel: (1) (213) 526 7412  
Fax: (1) (213) 526 7417

#### **1. New York Area**

New York State/Federal Inspection Office  
State of New York  
Suffolk County State Office Building  
Hauppauge, NY 11787-5532 United States  
Tel: (1) (516) 952 3079  
Fax: (1) (516) 952 3390

For additional information on the Seafood Inspection Program contact:

National Marine Fisheries Service  
Seafood Inspection Program  
1315 East-West Highway  
Silver Spring, MD 20910 United States  
Tel: (1) (301) 713 2355  
Fax: (1) (301) 713 1081  
Internet: <<http://seafood.ssp.nmfs.gov/iss/issue.html>>

## **V. UNITED STATES DEPARTMENT OF THE INTERIOR United States Fish & Wildlife Service (US F&WS)**

As the United State's principal conservation agency, the Department of the Interior has the responsibility for most of the nationally owned public lands and natural resources. This includes assuring that the wisest use of the land and water resources, protecting fish and wildlife, preserving the environmental and cultural values of national parks and historical places and providing for the enjoyment of life through outdoor recreation.

## **VI. UNITED STATES DEPARTMENT OF AGRICULTURE (USDA) Animal and Plant Health Inspection Service (APHIS) International Services (IS) and Veterinary Services (VS)**

### **■ United State Origin Health Certificate**

The Animal and Plant Inspection Service (APHIS) protects and promotes United States agriculture. APHIS provides leadership in ensuring the health and care of animals and plants. APHIS has six (6) major program areas, two of which have significance to importers and exporters of United States fish and seafood: the International Services (IS) and Veterinary Services (VS).

### **■ International Services (IS)**

The mission of International Services (IS) is to provide leadership, management and coordination of "APHIS" international activities, with particular emphasis on protecting American agriculture/ aquaculture and enhancing United States exports.

International Services is the arm of APHIS that works outside of the United States to keep agriculture pests and diseases from entering the country, to facilitate agricultural exports, and to bring agricultural trade into harmony with agricultural health worldwide. IS duties overseas, includes facilitation of United States agricultural exports and providing pre-clearance of foreign commodities bound for the United States.

## ■ Veterinary Services (VS)

APHIS will certify the health status of exported aquatic animals when a certification is required by importing country. The certificate issued is called the “United States Origin Health Certificate.” Typically, importing countries will require that exported aquatic animals be inspected and tested for one or more specific diseases. APHIS maintains field offices in almost every state in the United States and a field force of trained personnel that can advise and assist aquaculture and other live aquatic producers with obtaining export health certification for the international movement of animals and products.

Exporters of live aquatic animals and products who are in need of export health certification should contact the APHIS office in their state. Informing the APHIS office about the proposed shipment as far in advance as possible is extremely advisable.

A second service provided by APHIS for aquaculture producers and shippers is assistance in obtaining the import requirements of foreign countries. However, ultimately, it is the responsibility of the shipper or producer to obtain a foreign country’s import requirements.

## ■ Standard Procedure for Certifying Aquacultured Species and Products for International Export

1. The exporting producer, working with the importer, obtains the health requirements for the regulating department/ministry of the importing country. The producer is responsible for certifying the accuracy of the requirements.
2. APHIS-VS conducts a site visit to evaluate the aquaculture production facility. The importing country’s requirements are used as a basis for the evaluation. Requirements common to all export shipments are reviewed including oversight of the facility by the accredited veterinarian; brood farm water source; brood stock identification; and diagnostic sampling protocol. Specific requirements of the importing country are also reviewed at this time. Site visits are conducted at a frequency determined by APHIS-VS.
3. The aquaculture producer’s accredited veterinarian collects required diagnostic samples. The accredited veterinarian forwards the samples to the APHIS-VS approved laboratory. The brood stock sampled must be identified on the laboratory submission document, including farm location and lot identity. The document must be complete and correspond to the Approved Laboratory test results.
4. The APHIS-VS approved laboratory transmits the diagnostic test results directly to APHIS-VS.
5. The accredited veterinarian completes the United States Origin Health Certificate and then forwards the certificate to APHIS-VS for review and endorsement.

- The certificate valid date will include the period of time when shipments may be made from a specific brood stock lot. The date may not be later than a reasonable, science-based time period for this
  - The certificate will be valid for only the country for which the importing country will be identified on the certificate.
6. The aquaculture producer will maintain a log of certificates and shipments to
- Health certificate number.
  - Destination country.
  -
- This log is forwarded to APHIS-VS at the end of each month.



## **SECTION FOUR: INSPECTION SYSTEMS**



### **7. HAZARD ANALYSIS CRITICAL CONTROL POINT (HACCP)**

The Hazard Analysis Critical Control Point (HACCP) concept can be described as a preventive system of control, particularly with respect to microbiological hazards which may occur during food production. HACCP considers food safety and wholesomeness.

*The Seven Principles or Steps in the traditional HACCP system are:*

8. Determine the hazards and risks associated with all aspects of the product being produced with respect to the end-use of such products.
9. Identify the critical control point(s) required to control the identified hazard(s).
3. Establish limits (Critical Limits) which must be met at each Critical Control Point (CCP) to control the identified hazard.
10. Establish Monitoring Procedures for each Critical Limit established at each CCP.
5. Establish Corrective Action to be taken if a Critical Limit is exceeded during monitoring. This Corrective Action is designed to bring the hazard back into control.
6. Establish a Record-Keeping System which provides positive documentation that Critical Limits are being met, and when not met, that Corrective Action was taken to bring the system back into control.
7. Establish Verification Procedures that demonstrate the HACCP system is functioning as planned.

The United Nations food standards group, *the Codex Alimentarius Commission*, has recommended that HACCP be adopted as a system for ensuring the safety of foods and the prevention of food-borne diseases. In order to export to North America or Europe, a company must demonstrate to the satisfaction of the regulating agencies that it is operating under an HACCP system.

## ■ Special Requirements for Molluscan Shellfish

Controlling the origin of molluscan shellfish (for example, from properly classified waters) is the most important preventive control for most hazards. HACCP plans of molluscan shellfish processors must include how this control is being performed, including how the processors are obtaining shellfish ONLY:

- ! From waters approved by a “shellfish control authority”.
- ! From harvesters who in compliance with local licensing requirement.
- ! If properly “tagged”.

## 2. ISO 9000

ISO 9000 standards are a system of quality assurance standards to help ensure that products are being produced under certain standards of quality. The system was developed by the International Standards Organization (ISO). ISO is a non-governmental organization and all standards developed by ISO are voluntary. ISO has no power to enforce or to implement the system. These common quality standards help to ensure that products produced by different manufacturers for different customers are of equal quality, hence the name ISO which is derived from the Greek word isos meaning “equal.”

In 1987, the international community through the International Standards Organization (ISO) produced the ISO 9000 standards.

The purpose of the ISO 9000 series of standards is to provide:

- Consistency and guidance in establishing quality systems. The objectives of the quality system are to achieve and sustain the quality of the product so as to meet the buyer’s needs and to provide confidence to both management and buyers that the intended quality is achieved. The ISO standards are written in mandatory terms so that they can be used as a contract between supplier and buyer. The standards are designed to protect the supplier as much as the buyer.

The series has five parts:

1. ISO 9000-A Guideline for the Selection and Use of the ISO Standards.
2. ISO 9001-A Model for Quality Assurance in Design/Development, Production, Installation and Servicing.
3. ISO 9002-A Model for Quality Assurance in Production and installation.
4. ISO 9003-A Model for Quality Assurance in Final Inspection and Test.
5. ISO 9004-A Guideline for Quality Management and Quality System Elements.

ISO 9000 and 9004 are guidelines. ISO 9000 is a guideline to establishing a quality system within a firm. It defines management responsibilities, principles and structures of a quality system and documentation and auditing procedures.

ISO 9001, 2, and 3 are the quality system models that can be used as contractual documents. The difference in the three relates to the complexity of the business process. For example, 9003 is a model for final product inspection only and is used when buying requirements only involve final product testing. ISO 9002 encompasses all of 9003 plus it includes processing controls. It is used when requirements include production or manufacturing. ISO 9001 encompasses all of 9002 and 9003 and includes a design or development function. It is used when requirements include product design/development and production.

The use of the ISO standards requires a quality manual, standard operating procedures and documentation (record keeping). The standards also require audits of a firm's quality system. Both internal and external audits are expected under ISO. Once a firm has established a quality system per the guidelines 9004 and the appropriate quality assurance model (9001, 9002 or 9003), the firm can become certified. To become certified to an ISO standard, an external (independent) audit of the quality system by an ISO registered third party is required.

ISO 9002 and HACCP are extremely compatible as both systems emphasize prevention of errors through proper controls as opposed to detection of errors through final or customer inspection. Both require processing controls, training and management commitment. In general, ISO requires more documentation and record keeping than HACCP.

ISO requirements are also compatible with Total Quality Management (TQM) systems. If a firm has a TQM system, they will probably find ISO standards easier to implement.



ISO 9000 certificates are issued by certification bodies independently of ISO, even when a particular body is a national standards organization that is an ISO member.

## ■ ISO Members

### **China (CSBTS)**

China Bureau of Technical Supervision  
4, Zhichun Road  
Haidian District  
P.O. Box 8010  
Beijing 100088, China  
*Telephone:* (86) 10 6 203 24 24  
*Telefax:* (86) 10 6 203 10 10

### **Japan (JISC)**

Japanese Industrial Standards Committee  
c/o Standards Department  
Ministry of International Trade and Industry  
1-3-1, Kasumigaseki, Chiyoda-ku  
Tokyo 100, Japan  
*Telephone:* (81) 3 35 01 20 96  
*Telefax:* (81) 3 35 80 86 37  
Internet: <<http://www.aist.go.jp/jisc/htm/jisc00.htm>>

### **Korea, Republic of (KNITQ)**

Korean National Institute of Technology and Quality  
1599 Kwanyang-dong  
Dongan-ku, Anyang-city  
Kyonggi-do 430-060, Korea  
*Telephone:* (82) 3 43 84 18 61  
*Telefax:* (82) 3 43 84 60 77

### **Singapore**

Singapore Productivity and Standards Board (PSB)  
1 Science Park Drive  
Singapore 118221  
*Telephone:* (65) 278 66 66  
*Telefax:* (65) 776 12 80  
Internet: <<http://www.psb.gov.sg/>>

**United States of America (ANSI)**

American National Standards Institute

11 West 42<sup>nd</sup> Street

13<sup>th</sup> Floor

New York, New York 10036, US

*Telephone:* (1) 212 642 49 00

*Telefax:* (1) 212 398 00 23

*Internet:* < <http://www.ansi.org/> >







**APPENDICES**  
**CHINESE TAIPEI AIR CARGO CONTACTS**

Airline	Telephone	Fax
Air Canada	(886) (02) 506-8167	(886) (2) 506-5386
Air Express Int'l. Singapore	(886) (02) 764-3960	(886) (2) 756-9106
Airborne Express	(886) (02) 757-6666	(886) (2) 757-6689
American Airlines	(886) (02) 563-1200	(886) (2) 542-8000
Asiana Airlines	(886) (02) 508-1114	(886) (2) 508-0960
Australia Asia	(886) (02) 531-1331	(886) (2) 531-1649
Cathay Pacific	(886) (02) 712-8228	(886) (2) 717-4834
China Airlines	(886) (02) 2715-2233	(886) (2) 251-45407
China Asia Airlines	(886) (02) 514-2821	(886) (2) 718-4257
Delta Airlines	(886) (02) 551-0923	(886) (2) 531-7364
DHL	(886) (02) 503-6858	(886) (2) 503-2781
EVA Airways	(886) (03) 351-5151	(886) (3) 335-2246
Federal Express	(866) (02) 788-3535	(886) (2) 788-2504
Korean Air	(886) (02) 521-4242	(886) (2) 561-1204
Northwest	(866) (02) 2772-2866	(886) (2) 719-0237
Silk Airlines	(866) (07) 227-0810	(886) (7) 226-0869
Singapore Airlines	(866) (02) 551-6655	(886) (2) 523-5955
TNT Express	(866) (02) 713-2345	(886) (2) 712-2345
Taiwan Airlines	(866) (02) 514-2783	(886) (2) 503-5398
Thai	(866) (02) 717-5299	(886) (2) 713-1910
US Airways	(866) (02) 776-6769	(886) (2) 776-6772
United Airlines	(866) (02) 703-4341	(886) (2) 709-7564
United Parcel Service	(866) (02) 288-33868	(886) (2) 288-33890

## HONG KONG AIR CARGO CONTACTS

Airline	Telephone	Fax
Air Canada	(852) 2759 9899	(852) 2759 9099
Airborne Express	(852) 2796 3223	(852) 2796 3881
ANA All Nippon Airlines	(852) 2848 4288	
Asiana Airlines	(852) 2523 2851	(852) 2524 6152
Cathay Pacific	(852) 2747 7722	(852) 2747 7000
Emery Worldwide	(852) 2796 3883	
JAL	(852)2769 7378	
Northwest	(852)2521 1019	
Singapore Airlines	(852) 2769 8613	(852) 2796 9458
Thai	(852) 2769 7411/-4	(852) 2766 3024
United Airlines	(852) 2305 1685/86	(852) 2754 2791
United Parcel Service	(852) 2735 3535	(852) 2738 5071

## SEOUL, REPUBLIC OF KOREA AIR CARGO CONTACTS

Airline	Telephone	Fax
Air Canada	(82) 02 757 9181	(82) 02 757 1660
Airborne Express	(82) 02 334 2161	(82) 02 334 7175
ANA (All Nippon Airlines)	(82) 02 752 1170	
Asiana Airlines	(82) 02 669 1397	(82) 02669 1194
Cathay Pacific	(82) 02 773 0344	(82) 02 756 0170
China Airlines	(82) 02 755 1523	(82) 02 756 0560
Emery Worldwide	(82)2 790 0061-5	
JAL	(82) 02 757 1714	
Korean Air	(82) 02 75 0747	(82) 02 779 2578
Singapore Airlines	(82) 02 3455 6702	(82) 02 774 1266
Thai	(82) 02 370 70077	(82) 02 661 1533
United Airlines	(82) 2 778 4965/66	(82) 2 318 7013
United Parcel Service	(852)2735 3535 (HK)	(852)2738 5071(HK)



## SINGAPORE AIR CARGO CONTACTS

Airline	Telephone	Fax
Air Canada	(65) 277-5688	
Airborne Express	(65) 542-6508	(65) 542-3716
ANA All Nippon Airlines	(65) 542-1111	
Cathay Pacific	(65) 542-5686	(65) 542-9456
China Airlines	(65) 737-2211	(65) 732-8627
DHL	1-800-285-8888	
Emery Worldwide	(65) 542-6644	(65) 542-5387
Federal Express	1-800-543-2811	(65)744-2656
JAL	(65) 542-1666	
Korean Air	(65) 542-0684	(65) 542-9875
Singapore Airlines	(65) 542-6294	
Thai	(65) 542-1222	(65) 542-1225
United Airlines	(65) 541-8336	(65) 543-0089
United Parcel Service	1-800-738-3388	(65) 326-2299

## TOKYO, JAPAN AIR CARGO CONTACTS

Airline	Telephone	Fax
Air Canada	(81) 3-586-0486	
Airborne Express	(81) 3-5461-8411	(81) 3-5461-8422
ANA (All Nippon Airlines)	(81) 3-5203-2255	
Asiana Airlines	(81) 0476-32-6188	(81) 0476-32-6090
Cathay Pacific	(81) 3-3545-8051	(81) 3-3595-8129
China Airlines	(81) 3-3436-1661	(81) 3-3431-3732
Delta Airlines	(81) 3-3667-8241	
Emery Worldwide	(81) 3-3669-9653	
JAL	(81) 3-5460-5747	
Korean Air	(81) 3-5443-3377	(81) 3-5443-3380
Northwest	(81) 3-3585-8791	
Singapore Airlines	(81) 3-213-1173	(81) 3-3287-2345
Thai	(81) 3-3593-0517	(81) 3-3593-3146
United Airlines	(81) 3-3817-4311	(81) 3-3817-4319
United Parcel Service	(852)2735-3535(HK)	(852)2738-5071(HK)

## LOS ANGELES, CALIFORNIA, USA AIR CARGO CONTACTS

Airline	Telephone	Fax
Air Canada	(1) 310-646-3921	(1) 310-646-0001
Air China	(1) 310-641-8888	(1) 310-641-0864
ANA All Nippon Airlines	(1) 310 417-0800	
American Airlines		(1) 310-646-2512
Asiana Airlines	(1) 310 642-0347	(1) 310- 642-0319
Cathay Pacific	(1) 310-417-0052	
China Airlines	(1) 310-646-4230	
Delta Airlines	(1) 310-646-4701	
Emery Worldwide		(1) 310-412-1489
JAL	(1) 310-646-2353	
Korean Air	(1) 310-646-9800	(1) 310-337-0762
Northwest	(1) 310-348-3852	
Singapore Airlines	(1) 310 646 6200	(1) 310-641-6348
Thai	(1) 310-670-8592	(1) 310-670-1057
United Airlines	(1) 310-646-4146	(1) 310-646-6043

## NEW YORK, NEW YORK, USA AIR CARGO CONTACTS

Airline	Telephone	Fax
Air Canada	(1) 718-244-0495	(1) 718-651-5467
Air China	(1) 718-528-0300	(1) 718-656-4785
ANA (All Nippon Airlines)	(1) 718-632-6460	
American Airlines	(1) 718-334-7400	(1) 718-632-3830
Asiana Airlines	(1) 718-244-7000	(1) 718-656-1122
Cathay Pacific	(1) 718-244-6260	(1) 718-244-6264
China Airlines	(1) 718-656-5545	(1) 718-995-8789
Delta Airlines	(1) 718-632-4487	(1) 718-632-2207
DHL	(1) 718-995-8132	(1) 718-656-8442
Emery Worldwide	(1) 718-995-1400	(1) 718-632-1809
EVA Airways	(1) 718-995-4928	(1) 718-995-4932
JAL	(1) 718-244-5100	
Korean Air	(1) 718-632-5550	(1) 718-632-5595
Northwest	(1) 718-632-3300	
Singapore Airlines	(1) 718-656-1020	(1) 718-244-1888
United Airlines	(1) 718-995-1400	(1) 718-632-1809

## MEASUREMENT CONVERSION CHART

To covert	Into	Multiply by
Centigrade	Fahrenheit	9/5th and add 32°F
Centimeters	Inches	0.3937
Centimeters	Meters	0.0100
Centimeters	Millimeters	10.000
Cubic feet	Cubic centimeters	28320.0000
Cubic feet	Cubic inches	1728.0000
Cubic feet	Liters	28.3200
Cubic inches	Cubic centimeters	16.38706
Cubic meters	Cubic feet	35.3100
Cubic meters	Cubic inches	61023,3779
Fahrenheit	Centigrade	Subtract 32°F and multiply by 5/9th
Feet	Centimeters	30.4800
Feet	Meters	0.3048
Feet	Inches	12.0000
Fluid Ounces (Imperial)	Milliliters	28.4123
Fluid ounces (Imperial)	Pints (Imperial)	0.0500
Fluid Ounces (US)	Milliliters	29.5729
Fluid ounces (US)	Pints (US)	0.0625
Grams	Ounces (avoirdupois)	0.0353
Imperial gallons	Liters	4.4560
Imperial gallons	US gallons	1.2009
Imperial pints	Fluid ounces (Imperial)	20.0000
Imperial pints	Liters	0.5682

Imperial quarts	Liters	1.1365
Kilograms	Pounds (16 ounces)	2.2046
Liters	Fluid ounces (Imperial)	35.1960
Liters	Fluid ounces (US)	33.8147
Liters	Imperial gallons	0.2200
Liters	Imperial pints	1.7598
Liters	US gallons	0.2642
Liters	US pints	2.1136
Liters	US quarts	1.0567
Meters	Centimeters	100.0000
Meters	Feet	3.2808
Meters	Inches	39.3700
Meters	Yards	1,093613
Millimeters	Centimeters	0.1000
Millimeters	Inches	0.0394
Ounces (avoirdupois)	Pounds	0.0625
Ounces (avoirdupois)	Grams	28.3495
Pounds	Ounces	16.000
Pounds	Grams	453.5924
Pounds (16 ounces)	Kilograms	0.4536
Tons (long)	Kilograms	1016.000
Tons (long)	Pounds	2240.0000
Tons (long)	Tons (Short)	1.1200
Tons (metric)	Kilograms	1000.0000
Ton (metric)	Pounds	2205.0000
Tons (Short)	Pounds	2000.000

Tons (Short)	Kilograms	907.1849
Tons (Short)	Tons (long)	0.8929
Tons (Short)	Tons (Metric)	0.9072
US gallons	Imperial gallons	0.8327
US gallons	Liters	3.7583
US pints	Fluid ounces (US)	16.0000
US pints	Liters	0.4732
US quarts	Liters	0.9463
Yard	feet	3
Yard	Meters	0.9144





## SELECTED INTERNET SITES

Asia-Pacific Economic Cooperation Secretariat < <http://www.apecsec.org.sg/>>

APEC Tariff Database < <http://www.apectariff.org>>

ASEAN Fisheries < [asean.fishnet.gov.sg](http://asean.fishnet.gov.sg)>

ASEAN Standards < <http://www.aseansec.org/accsq/sqmain.htm>>

ASEAN Secretariat URL < <http://www.aseansec.org/>>

United Nations Economic and Social Commission for Asia and The Pacific (ESCAP) Trade Facilitation Information Exchange (TraFIX) < <http://ecie.um.or.th>>

World Trade Organization (WTO) < <http://gatekeeper.juice.org/wto>>

World Bank < [www.worldbank.org](http://www.worldbank.org)>

Hong Kong Trade Development Council <<http://www.tdc.org.hk/main/main.html>>

Hong Kong Government Information Service < <http://www.info.gov.hk/isd/news/index.htm>>

Korean Overseas Information Service <[www.kois.go.kr](http://www.kois.go.kr)>

A Directory of Singapore Businesses < <http://www.asia1.com.sg/bizdir/>>

Singapore Yellow Pages < [www.yellowpages.com.sg](http://www.yellowpages.com.sg)>

Taiwan External Trade Development Council (CETRA) <<http://www.tptaiwan.org.tw/>>

Taiwan Yellow Pages < <http://tradepoint.amjes.com/tw/yp>>

Tokyo Fish Market < [www.mindnet.or.jp/tukji/tukji\\_e.htm](http://www.mindnet.or.jp/tukji/tukji_e.htm)>

World Aquaculture Society < [www.ansc.purdue.edu/aquanic/was.html](http://www.ansc.purdue.edu/aquanic/was.html)>

Commercial Fish and Shellfish Technologies <<http://mayflon.fst.vt.edu/cfast/>>

International Standards Organization <[www.iso.ch](http://www.iso.ch)>

China Airlines <[www.china.airlines.com](http://www.china.airlines.com)>

United Parcel Service < [www.ups.com/asia](http://www.ups.com/asia) >

Cathay Pacific Cargo < [www.cargo.cathaypacific-air.com](http://www.cargo.cathaypacific-air.com)>

ANA (All Nippon Airlines) Cargo <<http://svc.ana.co.jp/cargo>>

Asiana Airlines Cargo <[www.asianacargo.com](http://www.asianacargo.com)>

Air Canada Cargo <[www.aircanada.ca](http://www.aircanada.ca)>

Thai Airlines Cargo < [www.thaiair.com](http://www.thaiair.com)>

Korea Trade Association <[www.kotra.or.kr/](http://www.kotra.or.kr/)>

Hong Kong Trade Development Council <[www.tdc.org.hk/](http://www.tdc.org.hk/)>

Japan External Trade Organization (JETRO) <[www.jetro.go.jp](http://www.jetro.go.jp)>

Singapore Trade Development Board <[www.tdb.gov.sg](http://www.tdb.gov.sg)>

International Air Transport Association <[www.iata.org](http://www.iata.org)>

## CITES (Relevant Species)

The Convention on International Trade in Endangered Species of Wild Fauna and Flora (**CITES**) is an international treaty that has been in effect since 1975. CITES is the only global treaty whose focus is the protection of plant and animal species from unregulated international trade.

There are three appendices comprising CITES: Appendix I, which protects threatened species from all international trade; Appendix II, which regulates trade in species not threatened with extinction but which may become threatened if trade goes unregulated; and, Appendix III, which gives countries the option of listing native species already protected within their own borders.

Currently, there are 143 member countries committed to the principles established by CITES. In particular, that any trade in protected plant and animal species is sustainable and that there is a process through which member countries work together to ensure that wildlife trade is carried out in accordance with the treaty. CITES' administrative body is headquartered in Geneva, Switzerland, providing original CITES documents in three languages: English, French and Spanish.

The People's Republic of China (Hong Kong), Singapore, the Republic of Korea, the United States of America and Japan are CITES members.

There are a number of bony fish and molluscan species, most of which are not commercially valuable, that fall under CITES Appendix I or II. Species listings can be found on the U.S. Fish and Wildlife internet site: < <http://www.fws.gov/~r9dia/cites.html> > . However, for this manual all species listed under **Class Osteichthyes** and **Phylum Mollusca** are found in the following tables:

<b>TABLE 1</b>		
<b>Species</b>	<b>Common Name</b>	<b>Appendix</b>
<b>CLASS OSTEICHTHYES</b>	<b>BONY FISHES:</b>	
Order Ceratodontiformes (=Ceratodiformes)	Lungfishes:	
<i>Neoceratodus forsteri</i>	Australian lungfish	II
Order Coelacanthiformes:	Coelacanth:	
<i>Latimeria chalumnae</i>	Coelacanth, Gombasa	I
Order Acipenseriformes:	Sturgeons:	
<i>Acipenser naccarii</i>	Adriatic sturgeon, Italian sturgeon	II

<i>Scaphirhynchus suttkusi</i>	Alabama sturgeon	II
<i>Acipenser schrenckii</i>	Amur sturgeon	II
<i>Acipenser oxyrhynchus</i>	Atlantic sturgeon	II
<i>Acipenser baerii baicalensis</i>	Baikal sturgeon	II
<i>Acipenser sturio</i>	Baltic sturgeon	I
<i>Huso huso</i>	Beluga, European sturgeon, Giant sturgeon, Great sturgeon	II
<i>Acipenser fulvescens</i>	Bony sturgeon, Freshwater sturgeon, Great Lakes sturgeon, Lake sturgeon, Red sturgeon, Ruddy sturgeon, Rock sturgeon, Shell back sturgeon, Stone sturgeon, Switchtail	II
<i>Acipenser dabryanus</i>	Changjiang sturgeon, Dabry's sturgeon, River sturgeon, Yangtze sturgeon	II
<i>Psephurus gladius</i>	Chinese paddlefish, Chinese swordfish	II
<i>Acipenser sinensis</i>	Chinese sturgeon	II
<i>Acipenser transmontanus</i>	Columbia sturgeon, Oregon sturgeon, White sturgeon, Sacramento sturgeon	II
<i>Pseudoscaphirhynchus kaufmanni</i>	False shovelnose sturgeon, Large Amu-Dar shovelnose, Shovelfish	II
<i>Acipenser nudiventris</i>	Fringebarbel sturgeon, Ship sturgeon, Thorn sturgeon	II
<i>Acipenser medirostris</i>	Green sturgeon	II
<i>Acipenser oxyrhynchus desotoi</i>	Gulf sturgeon	II
<i>Scaphirhynchus platyrhynchus</i>	Hackleback, Sand sturgeon, Shovelnose sturgeon, Switchtail	II
<i>Huso dauricus</i>	Kaluga, Kaluga sturgeon	II
<i>Acipenser gueldenstaedtii</i>	Ossetra, Russian sturgeon	II
<i>Polydon spathula</i>	Paddlefish	II

<i>Scaphirhynchus albus</i>	Pallid sturgeon, White hackleback, White shovelnose, White sturgeon	II
<i>Acipenser persicus</i>	Persian sturgeon	II
<i>Acipenser mikadoi</i>	Sakhalin sturgeon	II
<i>Acipenser stellatus</i>	Sevruga, Star sturgeon, Starry sturgeon	II
<i>Acipenser brevirostrum</i>	Short-nosed sturgeon	I
<i>Acipenser baerii</i>	Siberian sturgeon	II
<i>Pseudoscaphirhynchus hermanni</i>	Small Amu-Dar shovelnose	II
<i>Acipenser ruthenus</i>	Sterlet	II
<i>Pseudoscaphirhynchus fedtschenkoi</i>	Syr-Dar shovelnose	II
<i>Psephurus gladius</i>	White sturgeon	II
Order Osteoglossiformes:	Bonytongues:	
<i>Arapaima gigas</i>	Arapaima	II
<i>Scleropages formosus</i>	Asian bonyfish	I
Order Cypriniformes:		
<i>Caecobarbus geertis</i>	African blind barb, Congo blind barb	II
<i>Chasmistes cujus</i>	Cui-ui	I
<i>Probarbus jullieni</i>	Ikan temolek, Pla eesok	I
Order Siluriformes:	Catfishes:	
<i>Pangasianodon gigas</i>	Thailand giant catfish	I
Order Perciformes:	Perch-like fishes:	
<i>Cynoscion macdonaldi</i>	Totoaba	I

<b>TABLE 2</b>		
<b>PHYLUM MOLLUSCA</b>		
<b>Species</b>	<b>Common Name</b>	<b>Appendix</b>
<b>CLASS: PELECYPODA (=Bivalvia)</b>	<b>CLAMS, MUSSELS:</b>	
<i>Conradilla caelata</i>	Birdwing pearly mussel	I
<i>Cyprogenia aberti</i>	Edible pearly mussel	II
<i>Dromus dromus</i>	Dromedary pearly mussel	I
<i>Epioblasma</i> (=Dysnomia) <i>curtisi</i> (=E. florentina <i>curtisi</i> )	Curtis' pearly mussel	I
<i>E. florentina</i> (=E. florentina <i>florentina</i> )	Yellow-blossom pearly mussel	I
<i>E. sampsoni</i>	Sampson's pearly mussel	I
<i>E. sulcata perobliqua</i>	White cat's paw mussel	I
<i>E. torulosa gubernaculum</i>	Green-blossom pearly mussel	I
<i>E. torulosa rangiana</i>	Tan-blossom pearly mussel	II
<i>E. torulosa torulosa</i>	Tuberculed-blossom pearly mussel	I
<i>E. turgidula</i>	Turgid-blossom pearly mussel	I
<i>E. walkeri</i>	Brown-blossom pearly mussel	I
<i>Fusconaia cuneolus</i>	Fine-rayed pigtoe mussel	I
<i>F. edgariana</i>	Shiny pigtoe mussel	I
<i>F. subrotunda</i>	Long solid mussel	II
<i>Hippopus</i> spp. (See <i>Tridacnidae</i> spp.) <i>Lampsilis brevicula</i>	Ozark lamp pearly mussel	II
<i>L. higginsii</i>	Higgin's eye mussel	I
<i>L. orbiculata orbiculata</i>	Pink mucket mussel	I
<i>L. satur</i>	Plain pocketbook mussel	I
<i>L. virescens</i>	Alabama lamp pearly mussel	I

<i>Lexingtonia dolabelloides</i>	Slab-side pearly mussel	II
<i>Plethobasus cicatricosus</i>	White wartyback mussel	I
<i>P. cooperianus</i>	Orange-footed pimpleback mussel	I
<i>Pleurobema clava</i>	Club pearly mussel	II
<i>P. plenum</i>	Rough pigtoe mussel	I
<i>Potamilus (=Proptera) capax</i>	Fat pocketbook mussel	I
<i>Quadrula intermedia</i>	Cumberland monkey-face mussel	I
<i>Q. sparsa</i>	Appalachian monkey-face mussel	I
<i>Toxolasma (=Carunculina) cylindrella</i>	Pale lilliput pearly mussel	I
<i>Tridacna derasa</i>	Giant clam	II
<i>T. gigas</i>	Giant clam	II
Tridacnidae spp. (Includes all species in genera <i>Hippopus</i> and <i>Tridacna</i> except those with earlier date in Appendix II - check with customs officials for listing dates)	Giant clams	II
<i>Unio (=Megalonaias) nickliniana</i>	Nicklin's pearly mussel	I
<i>U. (=Lampsilis or Cyrtonaias) tampicoensis tecomatensis</i>	Tampico pearly mussel	I
<i>Villosa (=Micromya) trabalis</i>	Cumberland bean mussel	I
<b>CLASS GASTROPODA:</b>	<b>SNAILS:</b>	
<i>Achatinella</i> spp.	Oahu tree snails	I
<i>Papustyla (=Paupina) pulcherrima</i>	Manus Island tree snail	II
<i>Paryphanta</i> spp. (New Zealand species only)	New Zealand amber snails	II
<i>Strombus gigas</i>	Queen conch	II





## EXPORT GLOSSARY

**Ad Valorem** “According to value”. See duty

**Agent.** See Foreign Sales Agent

**Air Waybill.** A bill of lading which covers both domestic and international flights transporting goods to a specified destination

Technically, it is a non-negotiable instrument of air transport which serves as a receipt for the shipper, indicating that the carrier has accepted the goods listed therein and obligates itself to carry the consignment to the airport of destination according to specified conditions.

**Antidiversion Clause.** See destination Control Statement

**ATA Carnet.** A Customs document permitting the holder to carry or send merchandise temporarily into certain foreign countries (for display, demonstration or international exhibits) without paying duties or posting bonds (not needed for seafood in most countries unless samples are brought back to the country of origin).

**Auction.** Sale at which product is sold to the highest bidder.

**Certificate of Origin.** A document certifying that merchandise (such as perishable goods) was in good condition immediately prior to shipment

**C&F. “Cost and Freight”.** A pricing term indicating that these costs are included in the quoted price.

**Chamber of Commerce.** An association of businesspeople organized to promote local business interests.

**C&I. “Cost and Insurance”.** A pricing term indicating that these costs are included in the quoted price

**CIF . “Cost, Insurance, Freight”.** A pricing term indicating that these costs are included in the quoted price.

**CIF&C. “Cost, Insurance, Freight and Commission”** A pricing term indicating that these costs are included in the quoted price

**CIF&E. “Cost, Insurance, Freight and (Currency) Exchange.”** A pricing term indicating that these costs are included in the quoted price.

**CITES** Convention on International Trade in Endangered Species of Wild Fauna and Flora. A global treaty whose focus is the protection of plant and animal species from unregulated international trade.

**Clean Bill of Lading.** A receipt for goods issued by a carrier with an indication that the goods were received in “Apparent good order and condition” without damages or other irregularities. Compare Foul Bill of Lading.

**Collection Papers.** All documents (invoices, bills of lading, etcetera. Submitted to a buyer for the purpose of receiving payment for a shipment.

**Commercial Invoice.** An itemized list of goods shipped, usually included among an exporter’s collection papers

**Commission Agent.** See purchasing agent

**Consignee.** The receiver of a shipment.

**Consignment.** Delivery of merchandise from an exporter (the consignor) to an agent (the consignee) under agreement that the agent sell the merchandise for the account of the exporter. The consignor retains title to the goods until the consignee has sold them. The consignee sells the goods for commission and remits the net proceeds to the consignor.

**Consignor.** The sender of a shipment.

**Consular Declaration.** A formal statement, made to the consul of a foreign country, describing goods to be shipped.

**Consular Invoice.** A document, required by some foreign countries, describing a shipment of goods and showing information such as the consignor, consignee, and the value of the shipment. Certified by a consular official of the foreign country, it is used by the country's customs officials to verify the value, quantity and nature of the shipment.

**Countervailing Duty.** An extra duty imposed by a government to offset export grants, bounties or subsidies paid to foreign suppliers in certain countries by the governments of those countries as an incentive to export.

**Customs.** The authorities designated to collect duties levied by a country on imports and exports. The term also applies to the procedures involved in such collection

**Customshouse Broker.** An individual or firm licensed to enter and clear goods through Customs.

**Devaluation.** The official lowering of the value of one country's currency in terms of one or more foreign currencies.

**Distributor.** A foreign agent who sells directly for a supplier and maintains an inventory of the supplier's products.

**Drawback.** A refund of duties paid on imported goods which is provided at the time of their re-exportation.

**Duty.** A tax imposed on imports by the Customs authority of a country. Duties are generally based on the value of the goods (ad valorem duties), some other factor such as weight or quantity (specific duties), or a combination of value and other factors (compound duties).

**Ex "From"** When used in pricing terms such as "Ex plant" or "ex vessel" it signifies that the price quoted applies only at the point of origin (in the two examples at the seller's plant or at dockside). In practice, this kind of a quotation

indicates that the seller agrees to place the goods at the disposal of the buyer at a specified place within a fixed period of time.

**Exchange Rate.** The price of one currency in terms of another, that is the number of units of one currency that may be exchanged for one unit of another currency.

**Export.** To send or transport goods out of a country for sale in another country. In International sales, the exporter is usually the seller of the seller's agent. Compare import.

**Export Broker.** An individual or firm that brings together buyers and sellers for a fee but does not necessarily take part in the actual sales transactions.

**Export License.** A government document which permits the "licensee" to engage in the export of designated goods to certain destinations.

**Export Management Company.** A private firm that serves as the export department for several processors, soliciting and transacting export business on behalf of its clients in return for a commission, salary, or retainer plus commission.

**Export Merchant.** A company that buys products directly from processors, then packages and marks the merchandise for resale under its own name.

**Export Trading Company.** A firm that purchases foreign goods for resale in its own local market.

**FAS "Free Along Side"** A pricing term indicating that the quoted price includes the cost of delivering the goods alongside a vessel

**FOB "Free on Board"** A pricing term indicating that the quoted price includes the cost of loading the goods into transport vessels at the specified place.

**Foreign Exchange.** The currency or credit instruments of a foreign country. Also transactions involving purchase and/or sale of currencies.

**Foreign Sales Agent.** An individual or firm that serves as the foreign representative of a domestic supplier and seeks sales abroad for the supplier.

**Foul Bill of Lading.** Receipt from the carrier indicating that the goods were received in damaged condition,

**Free Port.** An area such as a port city into which product may be legally moved without the payment of duties.

**Free Trade Zone.** A port designated by the government of a country for duty-free entry of any non-prohibited goods. Product may be stored, displayed, used for processing, etc. within the zone and re-exported without duties being paid. Duties are imposed on the product (or items processed from the product) only when the goods pass from the zone into an area of the country subject to the Customs Authority.

**Foreign Trade Zone.** See Free Trade Zone.

**Freight Forwarder.** An independent business which handles export shipments for compensation. Your freight forwarder is among the best sources of information and assistance on regulations and documentation, shipping methods and foreign import regulations.

**GATT “General Agreement on Tariffs and Trade.”** A multilateral treaty, the purpose of which is to help reduce barriers between the signatory countries and to promote trade through tariff concessions. WTO, the World Trade Organization, has succeeded GATT.

**Gel Pack.** A non-water coolant enclosed in a plastic outer layer that can be frozen and then used to keep product chilled.

**General Export License.** Any of the various export licenses covering export commodities for which Validated Export Licenses are not required. No formal application or written authorization is needed to ship exports under a general export license.

**Gross Weight.** The full weight of a shipment, including goods and packaging.

**HACCP.** Hazard Analysis Critical Control Point. An inspection system required for import into the European Union and the United States.

**Harmonized Commodity Code.** A uniform numerical coding system that is used to identify commodities, track imports/exports and to levy import taxes..

**IATA.** International Air Transport Association. A trade association of air carriers that provides information and standardized procedures for handling cargo.

**Ike Jime.** A method of paralyzing and bleeding fish to maintain quality.

**International Standards Organization.** A non-government body that has established standards to provide uniformity in handling and processing.

**Import.** To bring foreign goods into a country. In international sales, the importer is usually the buyer or an intermediary who accepts and transmits goods to the buyer.

**Import License.** A document required and issued by some national governments authorizing the importation of goods into their individual countries.

**Joint Venture.** A business undertaking in which more than one firm share ownership and control.

**Letter of Credit (L/C).** A document, issued by a bank, per instructions by a buyer of goods, authorizing the seller to draw a specified sum of money under specified terms, usually the receipt by the bank of certain documents within a given time.

**Licensing.** A business arrangement in which the processor of a product (or a firm with proprietary rights over certain technology, trademarks, etcetera) grants permission to some other group of individual to process that product (or make use of that proprietary material) in return for specified royalties or other payment.

**MAP Packaging.** A packaging system in which air is replaced by a mixture of other gases to inhibit the growth of microorganisms and to reduce oxidative reactions.

**Marking (or Marks).** Letters, numbers and other symbols placed on cargo packages to facilitate identification.

**Packing List.** A list showing the number and kinds of items being shipped, as well as other information needed for transportation purposes.

**Polystyrene.** A stiff foam material used as an insulation. Styrofoam.

**Polyurethane.** A light-weight foam polymer used as insulation.

**Proforma Invoice.** An invoice provided by a supplier prior to the shipment of merchandise, informing the buyer of the kinds and quantities of goods to be sent, their value and important specifications (weight, size, etcetera).

**Purchasing Agent.** An agent who purchases good in his/her own country on behalf of foreign importers such as government agencies and large private concerns.

**Quota.** The quantity of a specific kind that a country will permit to be imported without restriction of imposition of additional duties. (In many countries, seafood import quotas are based on how well their domestic fleet performs.)

**Quotation.** An offer to sell goods at a stated price and under specific conditions.

**Representative.** See Foreign Sales Agent.

**Rigor mortis.** A stage of muscle stiffness that occurs after death.

**Shipper's Export Declaration.** A form required for shipments in certain markets. The form indicates the value, weight, destination and other basic information about an export shipment.

**Styrofoam.** Trademark. A light polystyrene foam used as an insulation

**Through Bill of Lading.** A single bill of lading covering both the domestic and international carriage of an export shipment. An air waybill for instance, is essentially a through bill of lading used for air shipments.

**Value Added Tax.** A flat tax that is levied on products at each stage of the marketing chain.

**Wetlock Box.** A specially constructed fiberboard box that has been treated with a waterproofing material on the inside and the outside. These are commonly used for the transport of seafood products.

**World Trade Organization.** The World Trade Organization (WTO) was established on January 1, 1995 as the multilateral institution charged with administering agreed-upon rules for trade among member countries. It succeeded the General Agreement on Tariffs and Trade (GATT)



# **AIR SHIPMENT OF LIVE AND FRESH FISH & SEAFOOD GUIDELINES**

**First Edition  
January 1999**

Published for the APEC Secretariat  
APEC Fisheries Working Group  
438 Alexandra Road  
#14-01/04 Alexandra Point  
Singapore 119958  
Tel: (65) 276 1880  
Fax: (65) 276 1775  
Email: [info@mail.apecsec.org.sg](mailto:info@mail.apecsec.org.sg)  
Web site: <http://www.apecsec.org.sg>  
81998 APEC Secretariat  
APEC #98-FS-03.1  
ISBN # 0-9669316-0-2

Developed by:

First Coastal Corporation  
4 Arthur Street Post Office Box 1212  
Westhampton Beach, New York 11977 USA  
Telephone: (1) 516-288-2271  
Fax: (1) 516-288-8949  
E-mail: [mail@firstcoastal.net](mailto:mail@firstcoastal.net)

