



United States
Department of
Agriculture

Forest Service

Forest
Products
Laboratory

Research
Paper
FPL-RP-589



Roof Temperature Histories in Matched Attics in Mississippi and Wisconsin

Jerrold E. Winandy
H. Michael Barnes
Cherilyn A. Hatfield



Abstract

To address the problem of defining actual field temperatures of various wood components in wood-framed roof systems, roof temperatures were monitored in test structures situated in the northern and southern United States (Madison, Wisconsin, and Starkville, Mississippi, respectively). The field exposure structures were intended to simulate the attics of multifamily wood-framed structures for which Model Building Codes sometimes allow the use of fire-retardant-treated roof sheathing. The structures were instrumented to monitor interior attic air, exterior air, inner and outer plywood roof sheathing, and internal rafter temperatures in dry white-shingled structures and both dry and heavily humidified black-shingled structures. Temperatures were recorded from January 1992 through December 1999 in Wisconsin and from January 1996 through December 1999 in Mississippi. The Mississippi exposure generally induced 5°C to 10°C higher temperatures than did the Madison exposure, though the difference in annual maximum “1-h average” temperature of both exposures was usually no more than 3°C to 4°C.

Overall, black-shingled roof systems tended to be 5°C to 10°C warmer during the midafternoon of a sunny day than were comparable white-shingled roof systems. Few differences in plywood roof sheathing temperatures were noted between dry and heavily humidified structures. Attic air-space and rafter temperatures were generally 5°C to 10°C cooler in humidified attics than in dry attics.

The major difference in the temperature of wood components in the Wisconsin and Mississippi structures occurred during the winter, when temperatures were as much as 20°C lower in Wisconsin.

Keywords: roof temperature, plywood, roof sheathing, rafter, thermal degrade, fire-retardant treatment, shingles, attic

December 2000

Winandy, Jerrold E.; Barnes, H. Michael; Hatfield, Cheryl A. 2000. Roof temperature histories in matched attics in Mississippi and Wisconsin. Res. Pap. FPL–RP–589. Madison, WI: U.S. Department of Agriculture, Forest Service, Forest Products Laboratory. 24 p.

A limited number of free copies of this publication are available to the public from the Forest Products Laboratory, One Gifford Pinchot Drive, Madison, WI 53705–2398. Laboratory publications are sent to hundreds of libraries in the United States and elsewhere.

The Forest Products Laboratory is maintained in cooperation with the University of Wisconsin.

The use of trade or firm names is for information only and does not imply endorsement by the U.S. Department of Agriculture of any product or service.

The United States Department of Agriculture (USDA) prohibits discrimination in all its programs and activities on the basis of race, color, national origin, sex, religion, age, disability, political beliefs, sexual orientation, or marital or familial status. (Not all prohibited bases apply to all programs.) Persons with disabilities who require alternative means for communication of program information (Braille, large print, audiotape, etc.) should contact the USDA’s TARGET Center at (202) 720–2600 (voice and TDD). To file a complaint of discrimination, write USDA, Director, Office of Civil Rights, Room 326-W, Whitten Building, 1400 Independence Avenue, SW, Washington, DC 20250–9410, or call (202) 720–5964 (voice and TDD). USDA is an equal opportunity provider and employer.

Contents

	<i>Page</i>
Problem.....	1
Objectives	1
Background.....	1
Methods	2
Exposure Structures	2
Recording of Temperatures.....	3
Measurement of Moisture Content.....	5
Results and Discussion.....	5
Sheathing Temperatures.....	5
Exceedance Temperatures	5
Maximum Temperatures	5
Annual Temperature Trends	6
Peak Temperature Trends	9
Moisture Content	11
Concluding Remarks.....	11
Acknowledgments.....	16
References.....	16
Appendix A—Exceedance Temperature Data for WI Structures	17
Appendix B—Exceedance Temperature Data for MS Structures	22

Roof Temperature Histories in Matched Attics in Mississippi and Wisconsin

Jerrold E. Winandy, Research Wood Scientist
Forest Products Laboratory, Madison, Wisconsin

H. Michael Barnes, Professor
Mississippi State University, Mississippi

Cherilyn, A. Hatfield, Statistician
Forest Products Laboratory, Madison, Wisconsin

Problem

In the late 1980s, the degradation of wood treated with some fire retardant (FR) chemicals in roof systems became a problem of major national significance. Thousands of cases were reported throughout the eastern United States (NAHB 1990). Our understanding of this deterioration in serviceability caused by thermal degrade has been limited because we have been unable to specifically correlate laboratory experiments using steady-state and cyclic temperature exposures with actual diurnal field temperature histories of FR-treated roof sheathing plywood. This lack of correlation has inhibited our ability to predict thermal-induced degradation of FR-treated plywood in the field from thermal degradation rates derived in the laboratory.

In many reports of field problems with FR-treated plywood roof sheathing, improper or nonfunctional ventilation of roof systems was attributed as a co-contributor to thermal degradation (LeVan and Collet 1989, NAHB 1990). This has resulted in questions about the relationship between roof system temperatures in damp, nonventilated attics compared with normally dry systems and the potential for synergy between roof temperatures and roof moisture.

Objectives

The primary objective of this work is to collect actual field data documenting the actual thermal load history of various wood components in traditional light-framed structures. The roof temperature histories presented in this report provide reasonable estimates of actual thermal loads. In addition, the histories provide insight into the effects of shingle color, attic humidity, and climate on thermal loads and a data base for modeling the residual serviceability of roof sheathing for known wood thermal degradation rates (Lebow and Winandy 1999). The secondary objective of this work is to use matched laboratory and field data on mechanical properties to develop specific laboratory-to-field correlations. These correlations will provide specific guidance for deriving the

cyclic factor used in Section 7 of ASTM D6305 (ASTM 1999) because the current cyclic factor is an arbitrarily derived estimate rather than a calculated estimate. This report specifically addresses the primary objective and presents the findings from one of more than a dozen interrelated studies conducted in a 10-year research program to develop residual serviceability models for roof sheathing (Winandy 2000).

Background

Heyer (1963) reported temperature histories for wall and roof systems for six houses and one office building for 1 week to 2 consecutive summers (June–August). The houses were located in Tucson, Arizona; Athens, Georgia; Portland, Oregon; Diboll, Texas; and Madison, Wisconsin. The office building, which had served as the original headquarters of the Forest Products Society, was located in Madison, Wisconsin. In any one year, maximum roof temperatures were found to reach as high as 75°C but the cumulative duration of temperatures over 70°C did not exceed 21 h, and the cumulative duration of temperatures over 65°C did not exceed 64 h. This was thought to be important considering that design standards for wood (AF&PA 1997) require a strength property adjustment for sustained exposures above 37.8°C and greater adjustment for prolonged exposures up to 65.6°C.

Roof temperatures attained by structures have been modeled. Ozkan (1993) and Wilkes (1989) reported on surface and various component temperatures in flat roof systems. Wood sheathing temperatures were not considered. In the study by Ozkan (1993), which was conducted in a very hot and dry area in Arabia, temperatures of roofing surfaces of a field station reached 93°C during a 1½-year period (April 1989 to November 1990). The primary use of the station was to observe the effects of weathering and to measure the temperatures of the bituminous and polymeric waterproofing membranes and thermal insulation materials. In the study by Wilkes (1989), temperatures of metal roofs in eastern Tennessee reached as high as 73°C during January and May. For more exposure temperature histories for shingles, the reader

is referred to studies by the National Bureau of Standards (NBS 1979) and Blackenstowe (1987). The temperature histories discussed hereafter pertain to wood components of roof systems.

Computer models have been developed that predict the average temperature and moisture content of plywood roof sheathing and other lumber roof members based on various construction details, materials, ventilation factors, and solar gain (radiation load) for the roof (APA 1989, ASTM 1988, TenWolde 1997, Wilkes 1989). The APA-Engineered Wood Association reported on a model that predicts temperatures of plywood roof sheathing under a black membrane in flat-roofed systems. This model predicts that sheathing temperatures of 65°C, 70°C, 75°C, and 80°C might be exceeded for up to 36, 13, 5, and 2 h, respectively, over the course of an average year in Hartford, Connecticut (APA 1989). Wilkes (1989) developed and reported a predictive roof temperature model for multi-layer nonwood roof systems. This model does not account for moisture flux, which may be critical in wood roof systems.

TenWolde developed and later verified (TenWolde 1988 and 1997, respectively) a predictive roof temperature model. In the 1997 report, he described a predictive roof temperature model especially for sloped wood-based roof systems. This model shows that the surface temperature of plywood roof sheathing is dominated by solar gain and the heat exchange between the surface and ambient air, not by attic ventilation. Diurnal (daily cyclic) temperature variation and hourly sheathing temperature histories are also influenced by the radiant energy absorptivity of the roofing surface, roof pitch, and, to a lesser extent, insulation and attic ventilation. The TenWolde model predicts that wet plywood sheathing dries quickly under warm summer conditions, even if ventilation is minimal. For example, if plywood is installed at 60% moisture content, the moisture content is roughly 15% after 1 week and falls to 8% in roughly 2 weeks. The model also indicates that the absorptivity of solar (radiant) energy by the roofing material has the greatest effect on increasing or reducing the average temperature of the plywood roof sheathing. If the absorptivity of the roofing material is 0.92, the model predicts the maximum hourly temperature for the roof sheathing plywood as 60°C and the maximum predicted exterior roof membrane temperature as 66°C. If the absorptivity is changed to 0.2, supposedly representing a metal roof system, both the maximum predicted sheathing temperature and maximum predicted membrane temperature drop to 35°C. Roof pitch has only a moderate influence on reducing the exterior surface temperature and the average temperature of the plywood. The model also predicts that the presence of insulation installed directly on the underside of the sheathing has virtually no influence on sheathing temperature on the top surface, but raises the average sheathing temperature relative to that of the top surface. When the ventilation rate in uninsulated systems is increased from 8 to about 21 air

changes per hour, almost no decrease of the top surface sheathing temperature or the average sheathing temperature is predicted.

In 1992, a test facility was constructed at the Building Research Council of the University of Illinois to measure heat transfer, moisture movement, and airflow in typical residential attic structures under natural conditions (Rose 1992). The results of that study showed that during the summer in central Illinois, attic ventilation could lower attic air temperature by 15.5°C but sheathing temperature by only 5°C; information on rafter temperatures was not given. Attic ventilation had only a minor effect on roof shingle temperature. The findings of Rose (1995) affirmed the earlier predictions of TenWolde (1988) and were then used to verify the TenWolde model (1997). Eventually, the TenWolde model was used to predict roof temperature histories for plywood roof sheathing at a dozen locations across the United States. Those predictions were used to predict engineering design adjustments for FR-treated plywood roof sheathing in ASTM Standard D6305-98 (ASTM 1999).

Methods

Exposure Structures

In the summer of 1991, five field exposure structures were constructed near Madison, Wisconsin (43° latitude). In Madison, the average incidence angle of sunlight is 19.5° from the southern horizon on the winter solstice (December 21) and 43° on the summer solstice (June 21). The annual average declination angle is 31.25°. The Wisconsin exposure structures (WI structures) were constructed to face south in a shadeless area open to direct sunlight. The structures were spaced far enough apart to prevent any one structure from shading the next structure. The construction of the WI structures was fully described by Winandy and Beaumont (1995).

In 1994, a USDA Competitive Grant was received to construct and monitor matched exposure structures at the Mississippi Forest Products Laboratory, Mississippi State University, in Starkville, Mississippi (33.5° latitude). This research was part of an ongoing effort to relate temperatures in matched northern to southern U.S. roof systems (Barnes and others 1993). In Starkville, the average incidence angle of sunlight is 32.3° from the southern horizon on the winter solstice and 74.8° on the summer solstice. The annual average declination angle is 53.5°. The five exposure structures in Mississippi (MS structures) were constructed to face south in a shadeless area open to direct sunlight. As for the WI structures, the MS structures were spaced far enough apart to prevent any one structure from shading the next structure. The data from the MS structures provide a direct measure of a more severe (higher solar loading) location compared with Madison, Wisconsin (Winandy and Beaumont 1995). A typical exposure structure is shown in Figure 1.



Figure 1—Exposure structures at Mississippi Forest Products Laboratory, Mississippi State University, Starkville, Mississippi.

Because of the slope of the Starkville test site, the east side of the MS structures was situated from 0.46 to 1.2 m off the ground, whereas the west side ranged from 0.15 to 0.46 m off the ground (Fig. 1). The WI structures were located on fairly flat ground and were approximately 0.5 m above grade.

All 10 exposure structures were identical. They were 3.7 m wide by 4.9 m long and constructed to simulate part of a typical multifamily attic–roof system in which U.S. Model Building Codes sometimes allow FR-treated plywood roof sheathing. To replicate this type of construction on a smaller scale, the 3.7-m-wide structures simulated in cross section the 1/8- to 3/8-span section of a 14.8-m span, 3:12 pitch roof system in both roof area and attic volume (Winandy and Beaumont 1995).

Each exposure structure was completely enclosed and unventilated. The four exterior walls were sheathed with 12-mm-thick, 200-mm-grooved Southern Pine siding attached to nominal 2- by 4-in. (standard 38- by 89-mm) wall studs. The exterior surfaces were coated with one coat of primer and two top coats of latex solid-color (light gray, almost white) stain or paint. The walls, floors, and roof system were not insulated.

The floor system was constructed from 9.5-mm-thick plywood floor sheathing and nominal 2- by 10-in. (standard 38- by 235-mm) joists. The rafters were made from nominal 2- by 6-in. (standard 38- by 140-mm) lumber, and the roof sheathing was 19-mm-thick plywood. Thick plywood roof sheathing was required because sixteen 100- by 550-mm openings were cut in each 1.2-m-wide by 2.4-m-long by 19-mm-thick panel to accommodate wood specimens used in the laboratory-to-field correlation studies. This study was intended to correlate thermal-induced degradation of FR-treated plywood in the field to matched FR-thermal-degradation rates derived in the laboratory (Barnes and others 1993).

The study variables were exposure location (Madison, Wisconsin, or Starkville, Mississippi), roof shingle color (black or white), and structure moisture content (heavily humidified or dry).

Recording of Temperatures

To assess the effect of shingle color, the exposure structures were roofed with black or white CertainTeed XT–25 (CertainTeed Corp., Blue Bell, PA) fiberglass shingles weighing 106 kg/square. The black and white shingles had reflectance values of 3.4% and 26.1%, respectively. Both black and white shingles had an emissivity rating of 0.91. These shingles were essentially identical to those used in Champaign, Illinois, to study the behavior of attics constructed and ventilated in various ways (Rose 1992). Two WI structures had white shingles; the remaining three WI structures and all five MS structures had black shingles.

Three of the five WI exposure structures were each instrumented with nine type-T thermocouples placed at various locations within the structure (Fig. 2). These structures were (1) a black-shingled structure that was not ventilated or humidified, (2) a black-shingled structure that was unventilated and artificially humidified from April through October to maintain >85% relative humidity for most of the diurnal cycle, and (3) a white-shingled structure that was not ventilated or humidified. In Mississippi, all five structures were instrumented with thermocouples as shown in Figure 2. Two MS structures were humidified using a cold steam atomizing humidifier system such that the relative humidity was maintained at >85% for most of the diurnal cycle. The interiors of the other three MS structures were kept dry.

The location and function of each thermocouple are described in Table 1. The thermocouples attached to the top ply of the roof sheathing (T3 and T4) were monitored because, theoretically, small roof systems such as the ones we tested have been reported to remain cooler than large roof structures since air flow heats as it travels across the roof surface. Rose (1992) reported the effects of such a phenomenon on sheathing temperatures for a 9.2-m-wide roof system compared with a 12.8-m-wide system. The position of thermocouple T7 allowed us to correlate rafter and sheathing temperatures. Thermocouple T8 acted as the external reference thermistor, with a rated accuracy of $\pm 0.2^{\circ}\text{C}$ between -33°C and 48°C . Overall, the data from the thermocouples allowed us to correlate the roof temperatures of wood materials in various locations in a wood roof system with solar loads. Solar loads were monitored by the U.S. Weather Service at Mississippi State University in Starkville, Mississippi, and at the Dane County Regional Airport in Madison, Wisconsin.

To collect and record the temperature data at each location (Wisconsin and Mississippi) from each thermocouple location, two Campbell–Scientific (Logan, UT) model CR10 dataloggers and two model AM416, 32-channel multiplexers

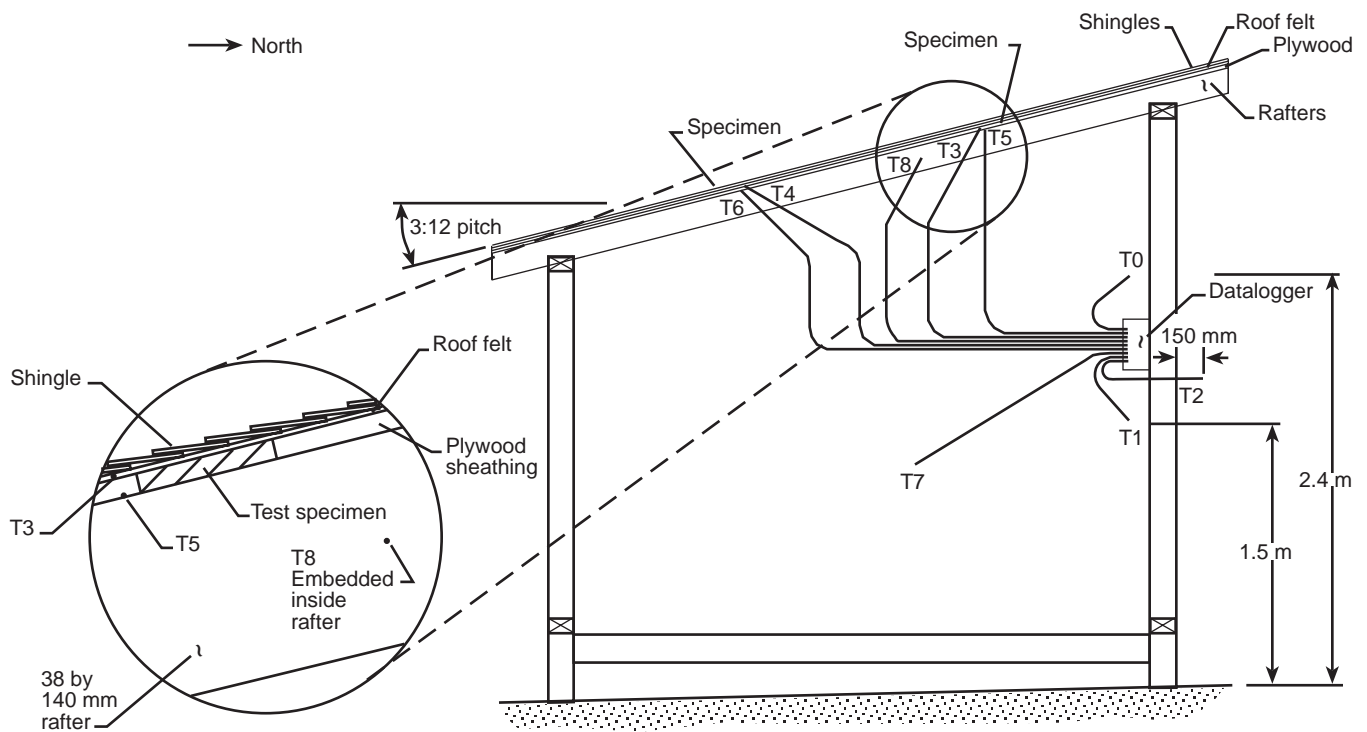

Figure 2—Schematic cross section of instrumented field exposure structure showing location of thermocouples (T0–T8) and channels for datalogger–multiplexer.

Table 1—Location and function of thermocouples in exposure structures^a

Thermocouple	Location	Measurement
T0	Central, along back (north) wall	Interior attic air temperature, 1 m above floor
T1	Central, along back (north) wall	Interior attic air temperature, 2 m above floor
T2	Central, along back (north) wall	Exterior air temperature, 2 m above grade
T3	Attached to top ply of plywood roof sheathing below roofing felt at 1/3 the rafter span, approximately 1.2 m from north (ridge) wall	Temperature of top ply of sheathing toward north wall
T4	Attached to top ply of plywood roof sheathing below roofing felt at 1/3 the rafter span, approximately 1.2 m from south (eave) wall	Temperature of top ply of sheathing toward south wall
T5	Attached to bottom ply of plywood roof sheathing at 1/3 the rafter span from the north (ridge) wall	Temperature of bottom ply of sheathing toward north wall
T6	Attached to bottom ply of plywood roof sheathing at 1/3 the rafter span from the south (eave) wall	Temperature of bottom ply of sheathing toward south wall
T7	Center of rafter at midspan	Correlation of rafter and sheathing temperatures
T8	Datalogger	External reference thermistor

^aAdditional detail is shown in Figure 2.

were used; one set (datalogger plus multiplexer) was used in Wisconsin and the other in Mississippi. The dataloggers had a reported accuracy of 0.2% over the service temperature range of -55°C to 85°C .

At each location, the datalogger and multiplexer were placed in a weather-sealed box located inside the middle structure of the five structures and located on a side wall approximately 1.83 m above the floor. Temperature data were collected every 5 min for each structure, and the datalogger was programmed to calculate and record hourly average temperatures. Each week, the hourly data were downloaded and saved using a laptop computer. The set-up of the datalogger and laptop computer in Mississippi is depicted on the cover of this report. The Wisconsin set-up was nearly identical and was previously described in detail by Winandy and Beaumont (1995).

Measurement of Moisture Content

At the Wisconsin site, moisture content was measured periodically at irregular intervals using an electrical resistance moisture content meter. The observations were collected during the day over the course of several years during all seasons. In Mississippi, moisture content was measured every 2 weeks over a 3-year period in four of the five exposure structures, except for one 4½-month period from late September 1998 to early February 1999.

Results and Discussion

The fact that the field structures were neither ventilated nor insulated means that the thermal data hereafter reported are truly indicative only of such constructions. Larger structures might theoretically experience slightly higher temperatures, but to exactly what degree is unknown (Rose 1992). Finally, because the attic floors were not insulated and not heated or cooled, as would probably be the case in a traditional light-framed wood structure, the cooler floors would be expected to subtly affect radiation exchange between the attic and underlying areas. However, we believe that much practical information can be learned from studying these field structure exposure temperature data.

We experienced thermocouple and multiplexer–datalogger problems in the WI heavily humidified (wet) black-shingled structure from January 1 to June 14 in 1996. We substituted the data from the WI dry black-shingled structure for this period because the dry and wet black-shingled structures in Wisconsin were found to have experienced very similar winter-to-spring temperatures in other years.

Sheathing Temperatures

Top- and bottom-of-sheathing temperatures were monitored at the one-third and two-third points in the roof, midway between the eaves and the ridge. In both the MS and WI structures, the difference in recorded hourly temperatures

between the two top-of-sheathing thermocouples (one-third and two-third span) seldom exceeded 1°C . This same $<1^{\circ}\text{C}$ difference was also found for the two bottom-of-sheathing thermocouples. The small difference in temperature between these two matched locations across the span of the structure shows that little practical difference really existed in the structures. This might be related to the small size of the test structures or their lack of ventilation. Rose (1992) found that increased ventilation in pitched, cathedral ceiling systems increased the across-the-span temperature differential. However, in a comparison of vented and unvented flat-roof systems, Rose (1995) found few differences in sheathing temperature between the eaves and the ridge. Our small difference in temperatures across the length of the roof span seems to confirm that few real differences exist in sheathing temperature between the eaves and the ridge. Accordingly, the two top-of-sheathing and two bottom-of-sheathing temperatures were averaged, and the average hourly value is reported.

Exceedance Temperatures

For the WI structures, the annual number of hours that the thermocouples recorded temperatures beyond various temperature limits were compiled into 5°C temperature bins. These 5°C bins (0°C to $<5^{\circ}\text{C}$, 5°C to $<10^{\circ}\text{C}$, ..., 70°C to 75°C) are hereafter defined as “exceedance temperatures.” The value reported as the exceedance temperature for 70°C is thus the number of hours the temperature at that thermocouple location equaled or exceeded 70°C , but is less than 75°C . Annual exceedance temperatures for the dry and wet black-shingled structures and dry white-shingled structure in Wisconsin, from 1992 to 1999, are given in Appendix A. Annual exceedance temperatures for the MS structures, from 1996 to 1999, are given in Appendix B. The exceedance temperature data were averaged over their 8- or 4-year history to produce an annualized roof temperature history for each configuration.

Maximum Temperatures

For the 4-year study at the Mississippi exposure site, maximum “1-h average” temperatures recorded for black-shingled roofs in dry structures were 78°C and 63°C for the top and bottom plies of the plywood roof sheathing, respectively, and 58°C for the rafter. The maximum temperatures recorded for the matched WI structures were 75°C , 59°C , and 54°C , respectively. MS and WI black-shingled structures showed only small differences (3°C to 4°C) in maximum record temperatures.

The maximum temperatures recorded for the WI white-shingled structure over the 8-year period were 64°C , 53°C , and 49°C for the top and bottom plies of the roof sheathing and the rafter, respectively. This clearly shows that the use of white shingles, as opposed to black shingles, can

dramatically lower the maximum temperatures—by 5°C to 11°C—in wood materials used in roof systems.

The maximum temperatures recorded in the 4-year Mississippi study for black-shingled roofs in heavily humidified structures were cooler than those for matched dry structures. For the wet black-shingled MS structures, maximum temperatures for the top and bottom plies of the roof sheathing and the rafter were 74°C, 58°C, and 54°C, respectively. The maximum temperatures of black-shingled roofs in heavily humidified structures in the 4-year Wisconsin study were cooler than those for matched dry WI structures. For the wet black-shingled WI structures, maximum temperatures for the top and bottom plies of the roof sheathing and the rafter were 74°C, 58°C, and 52°C, respectively. The maximum temperatures of wet MS and dry and wet WI structures were virtually identical. Daily 1-h maximum temperatures and annualized roof temperature data for Wisconsin exhibited similar values and trends to previously reported data from a 3-year study in Wisconsin (Winandy and Beaumont 1995).

Annual Temperature Trends

The average 8- or 4-year temperature histories for each thermocouple in each exposure structure are plotted for the WI structures in Figures 3 to 5 and for the MS structures in Figures 6 and 7. Note the general similarity in relative form of the exceedance temperature distributions between each exposure site, roof color, and attic humidity configuration. As expected, the MS structures experienced many more hours of exposure to high air temperatures than did the WI structures. However, although air temperatures were often warmer in Mississippi than in Wisconsin, the differences in annual maximum temperatures of the top and bottom of the plywood roof sheathing were very similar. We observed that the higher portions of the roof sheathing temperature histories were clearly controlled by solar radiation and not the outside air temperature (Figs. 3 to 7), which reaffirms the earlier observations of Winandy and Beaumont (1995) and the predictions of the TenWolde (1997) model. Figures 3 to 7 also show how internal rafter temperature is nearly coincident with inside attic air temperature and how both track relatively closely with outside air temperature. Thus, although solar radiation may control sheathing temperature, attic air space or rafter temperature is strongly influenced by outside air temperatures during most of the year.

Figures 8 to 11 show a direct comparison of temperatures recorded by individual thermocouples for each building configuration. Note that for both Mississippi and Wisconsin, the wet (heavily humidified) roof systems were generally similar in temperature to dry roof systems except during the hottest days or the highest portions of the temperature range. In the high temperature range, the thermocouples in nearly every location within the wet MS structures were usually 3°C to 4°C cooler than matched thermocouples in the dry MS structures. We believe that this was caused by evaporative

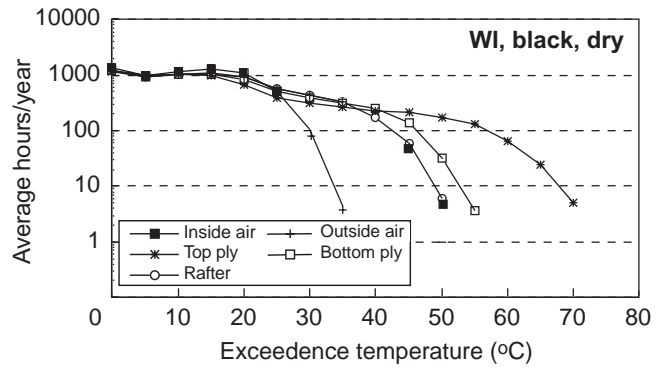

Figure 3—Annualized 8-year temperature history for dry black-shingled structure in Wisconsin.

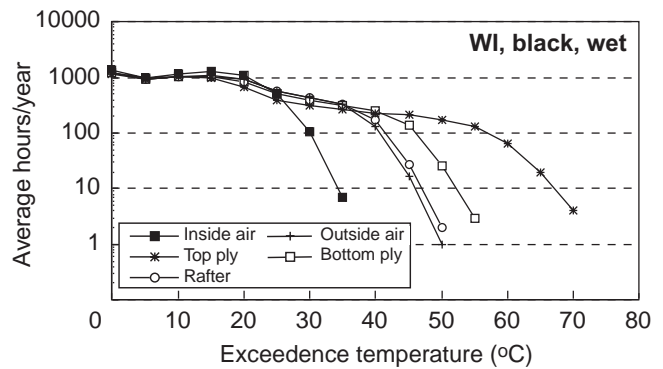

Figure 4—Annualized 4-year temperature history for wet black-shingled structure in Wisconsin.

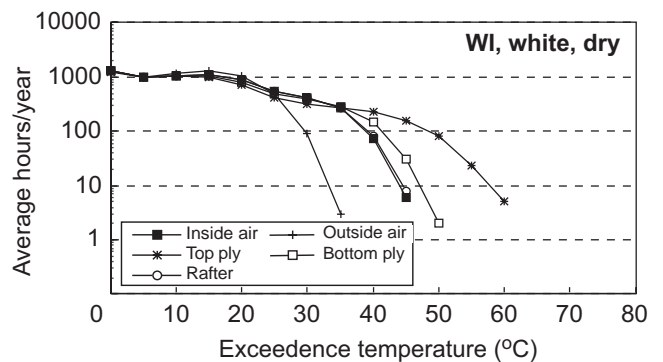

Figure 5—Annualized 8-year temperature history for dry white-shingled structure in Wisconsin.

cooling of the sheathing and rafter lumber during those warmest periods of each hot day. Although both the MS and WI wet structures experienced this same characteristic “evaporative cooling,” the matched wet and dry MS structures seemed to experience an even more pronounced deviation in thermocouple temperatures. We expect that this occurred because Mississippi has a warmer, more humid climate, and the MS exposure structures were subject to longer periods in the warmer, more humid temperature range,

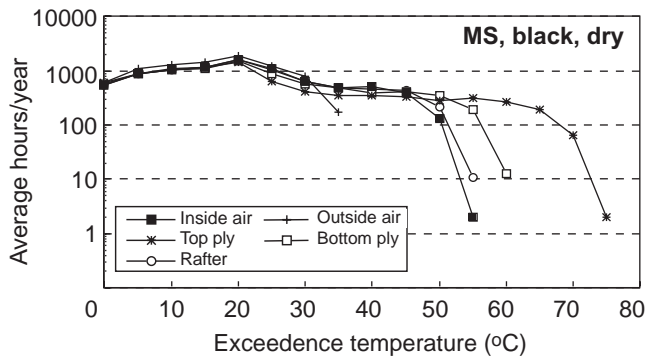

Figure 6—Annualized 4-year temperature history for dry black-shingled structure in Mississippi.

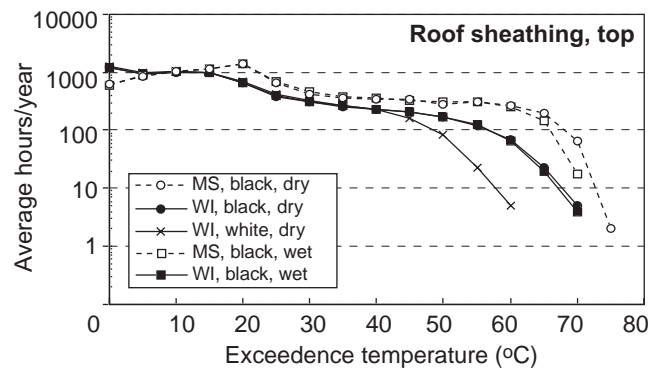

Figure 9—Air temperature history for top surface of plywood roof sheathing.

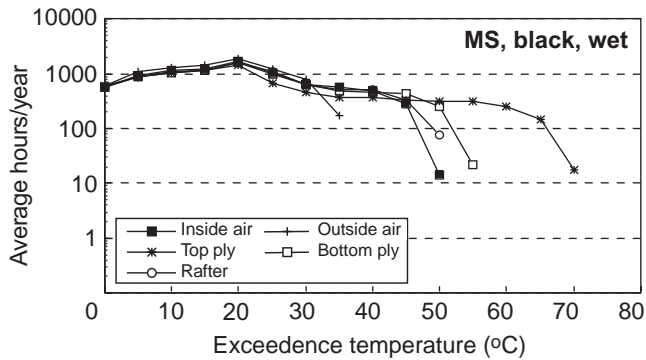

Figure 7—Annualized 4-year temperature history for wet black-shingled structure in Mississippi.

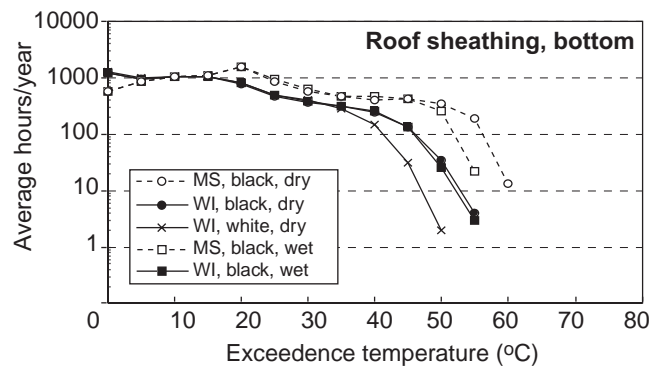

Figure 10—Air temperature history for bottom surface of plywood roof sheathing.

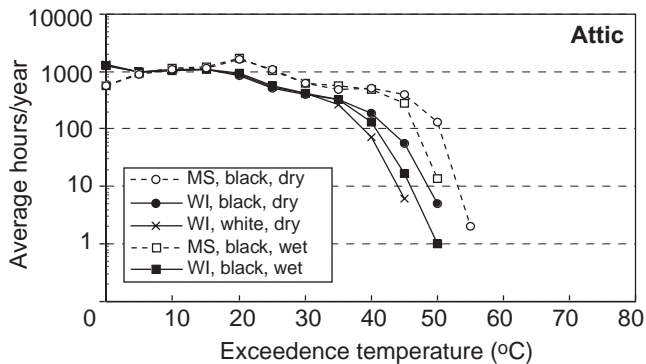

Figure 8—Attic air temperature history for test structures.

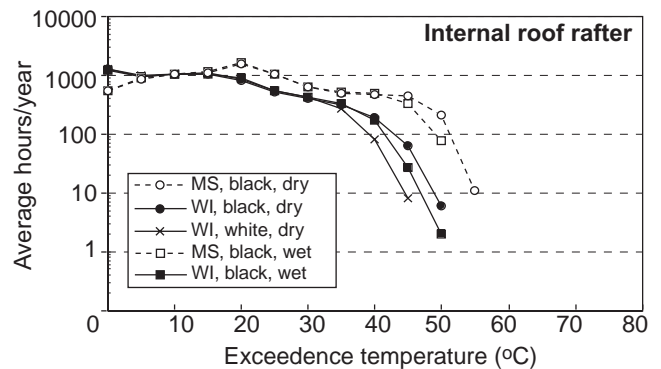

Figure 11—Air temperature history for internal rafters.

where measurable “evaporative cooling” would be more likely.

The warmer climate of Mississippi is readily apparent in the plot of the annualized 8- or 4-year average temperatures (Fig. 12a). Note that the temperature measured by each thermocouple was generally higher (by 10°C to 14°C) in the MS structures compared with the WI structures. Furthermore, temperatures of wet and dry structures were generally similar, except for the previously discussed deviation at the highest temperatures (Fig. 12b). In both the MS and WI

structures, the maximum plywood sheathing, rafter, and internal attic air temperatures during the monitoring periods were more similar than dissimilar, as earlier claims had suggested (ASTM 1988).

The minimum temperatures reveal the real difference in climatic influences for Mississippi and Wisconsin (Fig. 12c). Note that the annual minimum temperatures of wood components in WI structures (−35° to −40°C) were as much as 20°C colder than the minimum temperatures of MS structures (−20°C). Also note that the minimum temperatures of WI

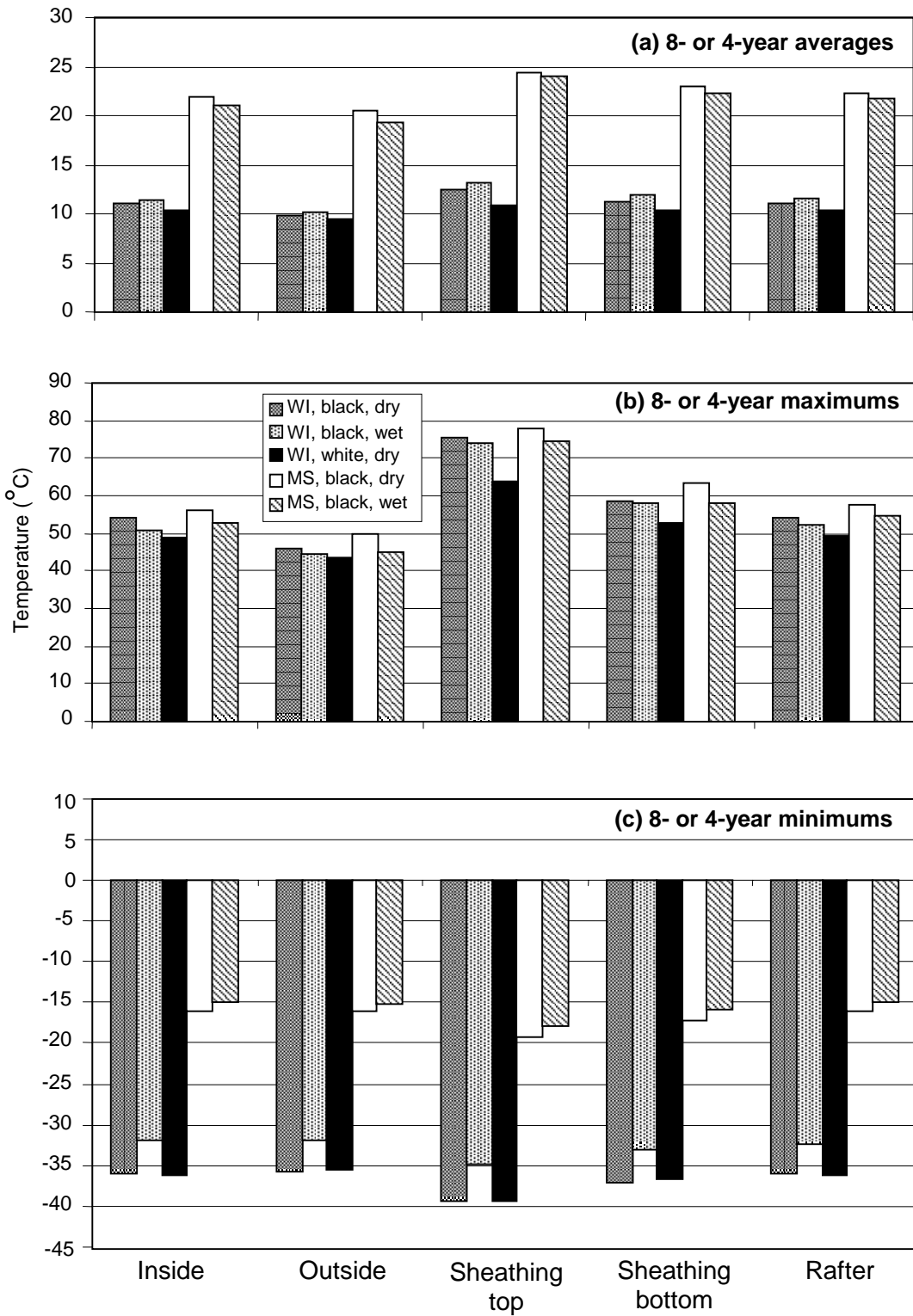

Figure 12—Average, maximum, and minimum 8- or 4-year temperatures for exposure structures.

Table 2—Eight-year average times at given temperatures for WI dry, black-shingled structure

Temperature (°C)	Time (h) at given temperature at various locations				
	Structure		Roof sheathing		
	Inside	Outside	Top	Bottom	Rafter
-40	0	—	1	1	1
-35	7	6	9	8	7
-30	13	15	18	14	13
-25	48	51	71	55	51
-20	149	162	172	156	149
-15	256	314	289	267	259
-10	548	622	595	571	561
-5	1,063	1,220	1,057	1,064	1,062
0	1,276	1,340	1,216	1,246	1,269
5	987	990	948	967	977
10	1,034	1,131	1,003	1,030	1,035
15	1,063	1,297	964	1,038	1,050
20	846	1,040	652	771	834
25	509	486	385	480	514
30	399	88	308	365	402
35	322	4	258	322	322
40	186	—	225	240	194
45	55	—	210	134	62
50	5	—	168	35	6
55	—	—	121	4	—
60	—	—	70	—	—
65	—	—	23	—	—
70	—	—	5	—	—
75	—	—	0	—	—

Table 3—Four-year average times at given temperatures for WI wet, black-shingled structure

Temperature (°C)	Time (h) at given temperature at various locations				
	Structure		Roof sheathing		
	Inside	Outside	Top	Bottom	Rafter
-40	1	—	2	1	1
-35	7	6	9	8	8
-30	12	14	14	12	11
-25	43	49	61	48	43
-20	138	161	160	151	142
-15	240	282	272	246	239
-10	523	554	568	555	532
-5	1,073	1,261	1,081	1,071	1,070
0	1,246	1,352	1,175	1,208	1,246
5	961	958	935	942	943
10	1,056	1,164	1,051	1,038	1,033
15	1,090	1,282	978	1,038	1,061
20	911	1,070	668	824	916
25	565	501	400	501	560
30	424	105	306	383	428
35	325	7	262	321	340
40	134	—	230	255	170
45	17	—	209	136	27
50	1	—	172	26	2
55	—	—	128	3	—
60	—	—	65	—	—
65	—	—	20	—	—
70	—	—	4	—	—
75	—	—	—	—	—

black- and white-shingled structures (Fig. 12c) were very similar to each other, whereas the maximum temperatures of these structures were very different from each other (Fig. 12b).

Annual outside air temperatures in Madison, Wisconsin, were distinctly bimodal. Thermocouple T2 readings showed two distinct peaks at 10°C to 15°C and -5°C to 0°C, with noticeably fewer values in the 5°C to 10°C range (Tables 2 to 4). The other thermocouple readings (attic air, top and bottom of plywood roof sheathing, and rafter) also showed signs of bimodality, but not as obviously. These findings are evident in the data for the WI structures by individual year and location—interior humidity configuration (Appendix A). The temperature histories of all thermocouple locations in the MS structures were unimodal (Appendix B). The Mississippi data did not exhibit the bimodal nature of the Wisconsin data. Tables 5 and 6 show the unimodal nature of the thermal loads for the MS structures.

Peak Temperature Trends

The temperatures achieved at each thermocouple location during the hottest 7-consecutive-day period over the 8- or 4-year history of each exposure structure are shown in Figures 13 and 14; the influence of exposure site and attic humidity during this time is shown in Figure 15. The individual “peak” temperatures recorded for both the dry black-shingled and dry white-shingled WI structures during the 8-year exposure period were similar to those recorded previously for a 3-year exposure study (Winandy and Beaumont 1995). Although the wood components under the white roofing material were much cooler on “peak” days than those under the black roofing material, the differences between sheathing temperatures of the dry black-shingled and dry white-shingled WI attics were minimal.

Table 4—Eight-year average times at given temperatures for WI dry, white-shingled structure

Temperature (°C)	Time (h) at given temperature at various locations				
	Structure		Roof sheathing		
	Inside	Outside	Top	Bottom	Rafter
-40	0	—	2	1	1
-35	7	6	9	8	7
-30	12	15	18	14	13
-25	47	50	74	55	50
-20	143	161	177	159	150
-15	258	308	296	273	262
-10	559	614	614	588	574
-5	1,074	1,213	1,111	1,097	1,085
0	1,308	1,333	1,248	1,288	1,307
5	993	996	976	985	987
10	1,058	1,145	1,045	1,062	1,057
15	1,102	1,278	1,003	1,061	1,086
20	888	1,061	700	821	868
25	546	492	408	490	538
30	428	91	318	397	427
35	266	3	271	287	266
40	73	—	227	148	82
45	6	—	161	31	8
50	—	—	83	2	—
55	—	—	23	—	—
60	—	—	5	—	—
65	—	—	—	—	—
70	—	—	—	—	—
75	—	—	—	—	—

Table 5—Four-year average times at given temperatures for MS dry, black-shingled structure

Temperature (°C)	Time (h) at given temperature at various locations				
	Structure		Roof sheathing		
	Inside	Outside	Top	Bottom	Rafter
-40	—	—	—	—	—
-35	—	—	—	—	—
-30	—	—	—	—	—
-25	—	—	—	—	—
-20	1	1	8	4	2
-15	13	14	29	15	13
-10	55	65	107	72	57
-5	202	243	331	258	215
0	552	591	609	562	544
5	882	1,080	857	866	870
10	1,078	1,273	1,043	1,048	1,057
15	1,150	1,423	1,159	1,108	1,139
20	1,596	1,925	1,398	1,532	1,563
25	1,070	1,193	641	866	1,036
30	639	783	421	581	647
35	494	176	355	482	493
40	507	—	348	399	466
45	398	—	338	418	445
50	130	—	284	356	211
55	2	—	310	190	11
60	—	—	272	13	—
65	—	—	194	—	—
70	—	—	64	—	—
75	—	—	2	—	—

As discussed previously in this report, wood components in the matched WI and MS structures experienced similar annual maximum temperatures, but MS structures were exposed to those peak temperature ranges for more hours each day. This result is clearly evident in the comparison of temperatures recorded over the hottest 7-consecutive-day period over the 8- and 4-year histories of the respective Wisconsin and Mississippi exposure sites (Figs. 13 and 14, respectively). The same scenario is evident in the temperature histories of wood components in the heavily humidified MS and WI structures. Like the temperatures of the dry structures, the individual annual peak temperatures of the wet black-shingled structures in Wisconsin (Fig. 13) and Mississippi (Fig. 14) were similar, but the daily peak temperatures in the MS structures were higher. These results suggest that the benefits and limitations of attic ventilation during warm summer periods are similar regardless of whether the buildings are located in the North or the South.

Many important trends can be summarized by analyzing the wood component and attic air temperatures over the hottest 7-consecutive-day period over the Wisconsin and Mississippi histories. Attic air temperatures were clearly higher in the MS structures than in the WI structures (Fig. 15). The effect of evaporative cooling is illustrated by the fact that attic air temperature in the MS wet black-shingled structure was similar to that in the WI dry black-shingled structure, and attic air temperature in the WI wet black-shingled structure was similar to that in the WI dry white-shingled structure. On the contrary, the top-of-sheathing temperatures of the dry and wet structures in both Mississippi and Wisconsin were very similar (Fig. 15). This seems to reinforce the idea that sheathing temperatures, especially temperatures at the top of the sheathing, are primarily controlled by solar radiation.

The temperatures of the bottom of the plywood sheathing fell between the temperatures recorded for the attic air and the top of the sheathing (Fig. 15). We observed that bottom-of-sheathing temperatures followed a thermal history that

Table 6—Four-year average times at given temperatures for MS wet, black-shingled structure

Temperature (°C)	Time (h) at given temperature at various locations				
	Structure		Roof sheathing		
	Inside	Outside	Top	Bottom	Rafter
-40	—	—	—	—	—
-35	—	—	—	—	—
-30	—	—	—	—	—
-25	—	—	—	—	—
-20	—	1	5	1	—
-15	8	14	14	11	9
-10	23	65	97	36	26
-5	229	243	316	254	232
0	578	591	601	568	559
5	915	1,080	871	867	887
10	1,130	1,273	1,032	1,058	1,079
15	1,213	1,423	1,160	1,130	1,169
20	1,686	1,925	1,425	1,581	1,632
25	1,028	1,193	686	961	1,074
30	625	783	456	646	652
35	557	176	378	473	524
40	480	—	366	471	508
45	283	—	324	430	339
50	14	—	312	256	78
55	—	—	312	22	—
60	—	—	250	—	—
65	—	—	145	—	—
70	—	—	18	—	—
75	—	—	—	—	—

seemed to be partially controlled by both the attic air and top-of-sheathing temperatures. Rafter temperatures also appeared to mirror the thermal history of bottom-of-sheathing temperatures. Rafter temperatures in the wet black-shingled MS structure fell between those of the MS dry black-shingled and WI dry black-shingled structures (Fig. 15). These observations reinforce the idea that the bottom-of-sheathing and internal rafter temperatures are jointly influenced by outside air and attic air temperatures and by solar radiation.

As discussed previously in this report, engineering design standards for wood (AF&PA 1997) require a strength property adjustment for sustained exposures above 37.8°C and greater adjustment for prolonged exposures up to 65.6°C. Average annualized exposures at various critical temperatures were derived using a nonparametric analysis. These values (Table 7) show the relative time the various wood building components spent in three AF&PA temperature regimes: (1) $\geq 37.8^\circ\text{C}$ but $< 51.7^\circ\text{C}$, (2) $\geq 51.7^\circ\text{C}$ but $< 65.6^\circ\text{C}$, and (3) $\geq 65.6^\circ\text{C}$. The data show that roof plywood sheathing and roof rafters are in these important temperature ranges for a significant portion of time. Recently derived models for the

residual serviceability of untreated wood roofing material have shown that such thermal loading might account for a 4% loss in strength for each 10 years of exposure in Madison, Wisconsin (Winandy 1998).

Moisture Content

Rose (1992) reported that when a good vapor barrier was maintained between warm living spaces and cooler attics, the moisture content (MC) of wood components used in flat- or cathedral-ceiling attics ranged from 8% to 22%, averaged between 13% and 15%, and was higher than 18% for less than 20 to 50 hours per year. These findings were similar regardless of whether the roof systems were ventilated or unventilated. However, Rose found that when the ceiling vapor barrier was broken, lumber in unventilated cathedral roof cavities could have more than 30% moisture content for more than 200 h/year. In our study, none of the MC measurements taken at the Wisconsin site was higher than 20% or lower than 6%. In winter, MC tended to range from 13% to 16% and in summer, from 8% to 12%. At the Mississippi site, wood MC was lowest during summer and highest during winter. In dry roof systems, sheathing MC varied from 1.5% in summer to 7.5% in winter; in artificially humidified roof systems, sheathing MC varied from 4% in summer to 17% in winter (Fig. 16). Thus, the results from the WI structures, which were not humidified during cold weather periods, and the MS structures, which were humidified all year long, affirm the trends in wood MC previously reported by Rose (1992).

Concluding Remarks

The results of this research study are summarized as follows:

- The annual 1-h maximum temperatures of various wood components were similar in Mississippi and Wisconsin roof systems; these temperatures were only 3°C to 4°C higher in the MS structures.
- Although the annual maximum and the form of the recorded exceedance temperatures were similar in the MS and WI exposure structures, the MS structures experienced temperatures in the higher range for many more hours per year compared to matched WI structures. Temperatures of wood components in the MS structures were generally 5°C to 10°C warmer than those of matched WI structures.
- Black-shingled roof systems tended to be 5°C to 10°C warmer on sunny afternoons compared with white-shingled systems.
- Moisture content of plywood roof sheathing in dry MS structures varied from 1.5% to 7.5% between summer and winter; moisture content of sheathing in wet (heavily humidified) MS structures varied from 4% to 17%. Moisture content of sheathing in dry WI structures varied from 6% to 13%.

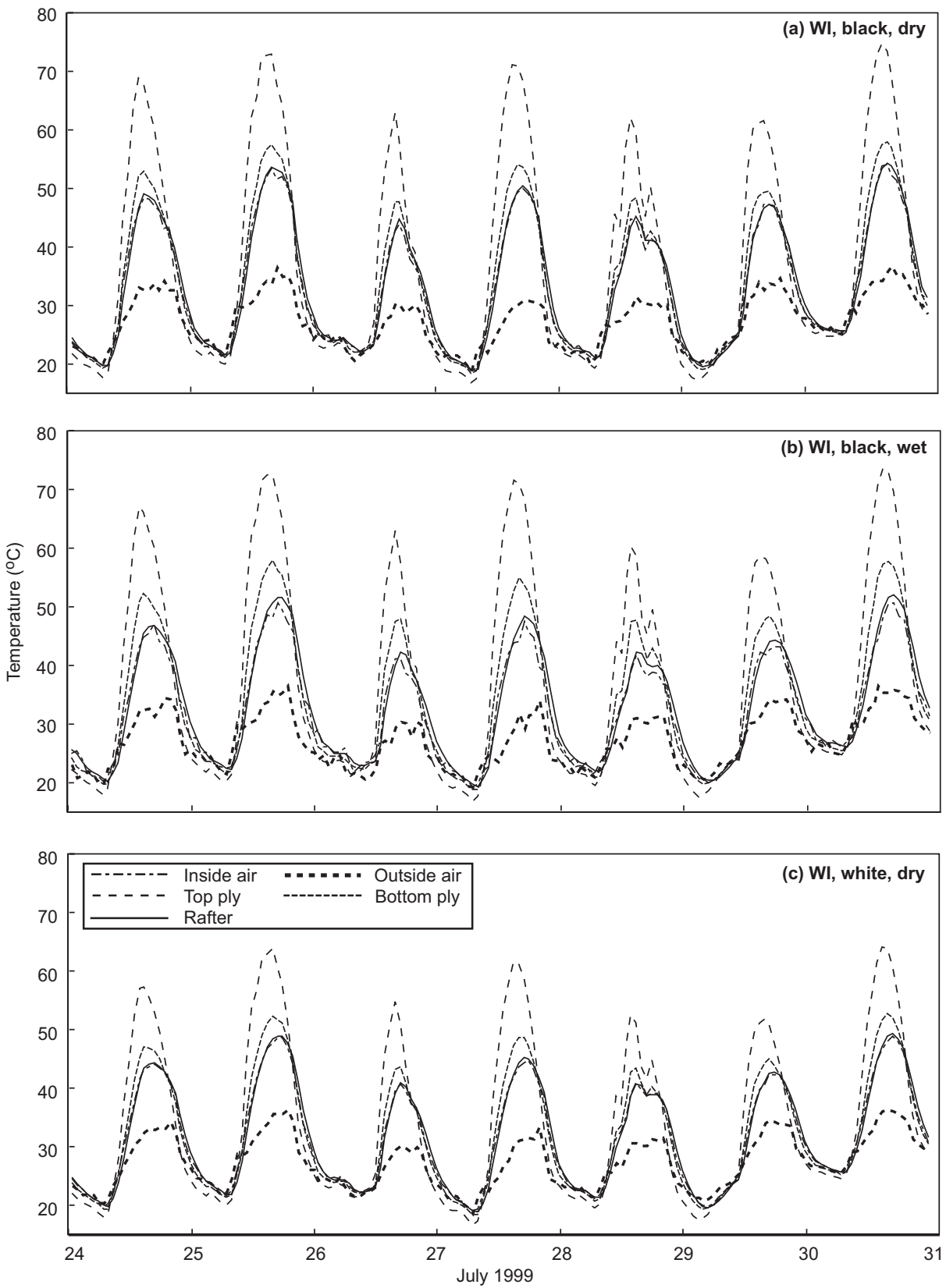

Figure 13—Temperatures at each thermocouple location during 7 hottest consecutive days in 8-year exposure of WI structures.

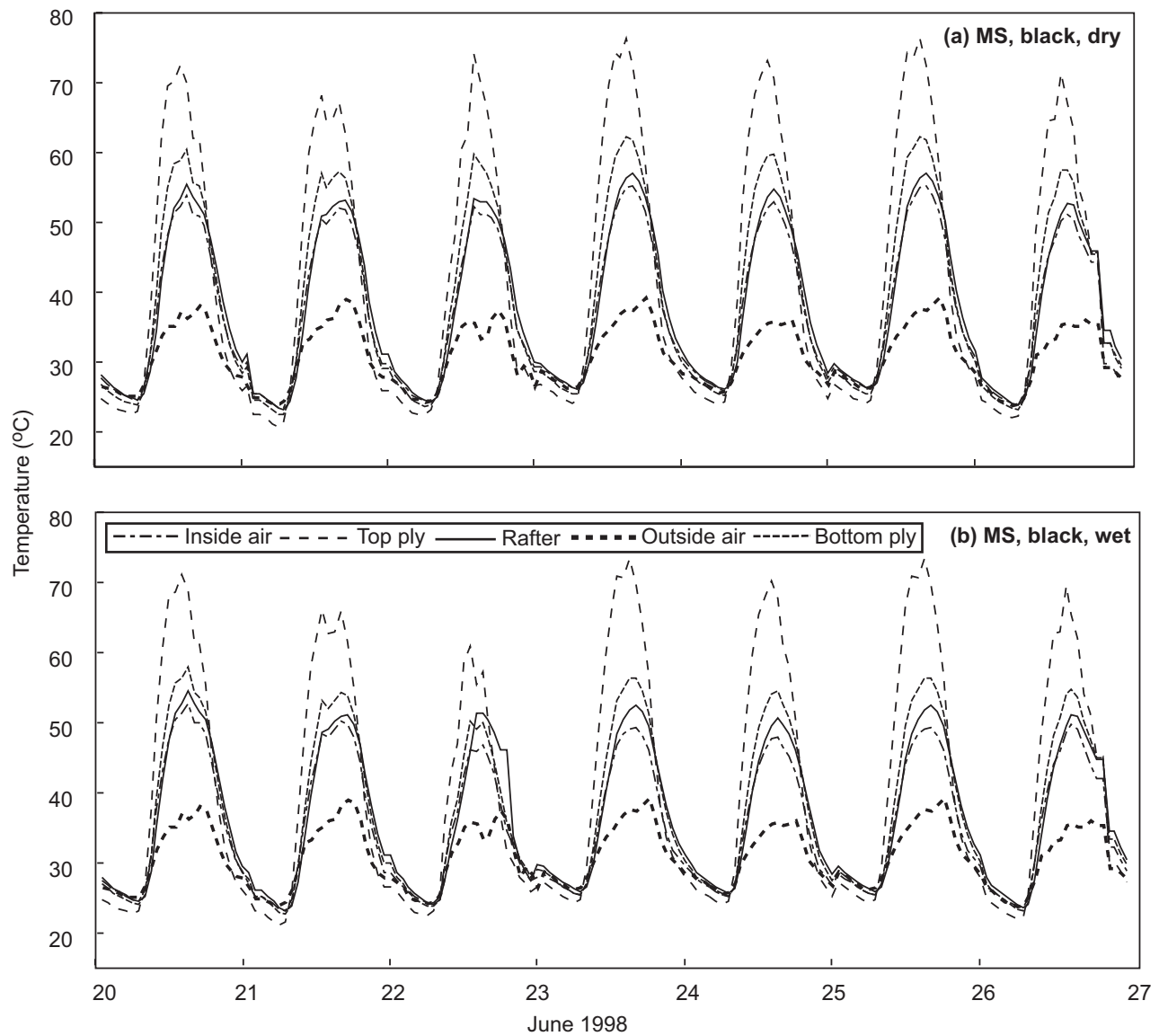

Figure 14—Temperatures at each thermocouple location during 7 hottest consecutive days in 4-year exposure of MS structures.

- Temperatures at the top of the roof sheathing were controlled by solar gain, not outside air or attic air temperatures.
- Temperatures at the bottom of the roof sheathing were usually controlled by solar gain, except on a few of the hottest days, when sheathing temperatures were also influenced by outside air or attic air temperatures.
- Rafter temperatures were usually controlled by attic air temperatures, except on a few of the hottest days, when they were also influenced by solar radiation.
- On hot days in heavily humidified structures, evaporative cooling is responsible for lower temperatures in plywood sheathing and wood rafters.
- The major difference in the temperature of wood components used in attics in the northern exposure (Wisconsin) compared with those used in the southern exposure (Mississippi) was in minimum temperatures, which were as much as 20°C lower in the WI structures.
- Annual outside air temperature is bimodal in Wisconsin, with two distinct peaks at 10°C to 15°C and -5°C to 0°C. Annual outside air temperature is unimodal in Mississippi, averaging between 10°C and 15°C.

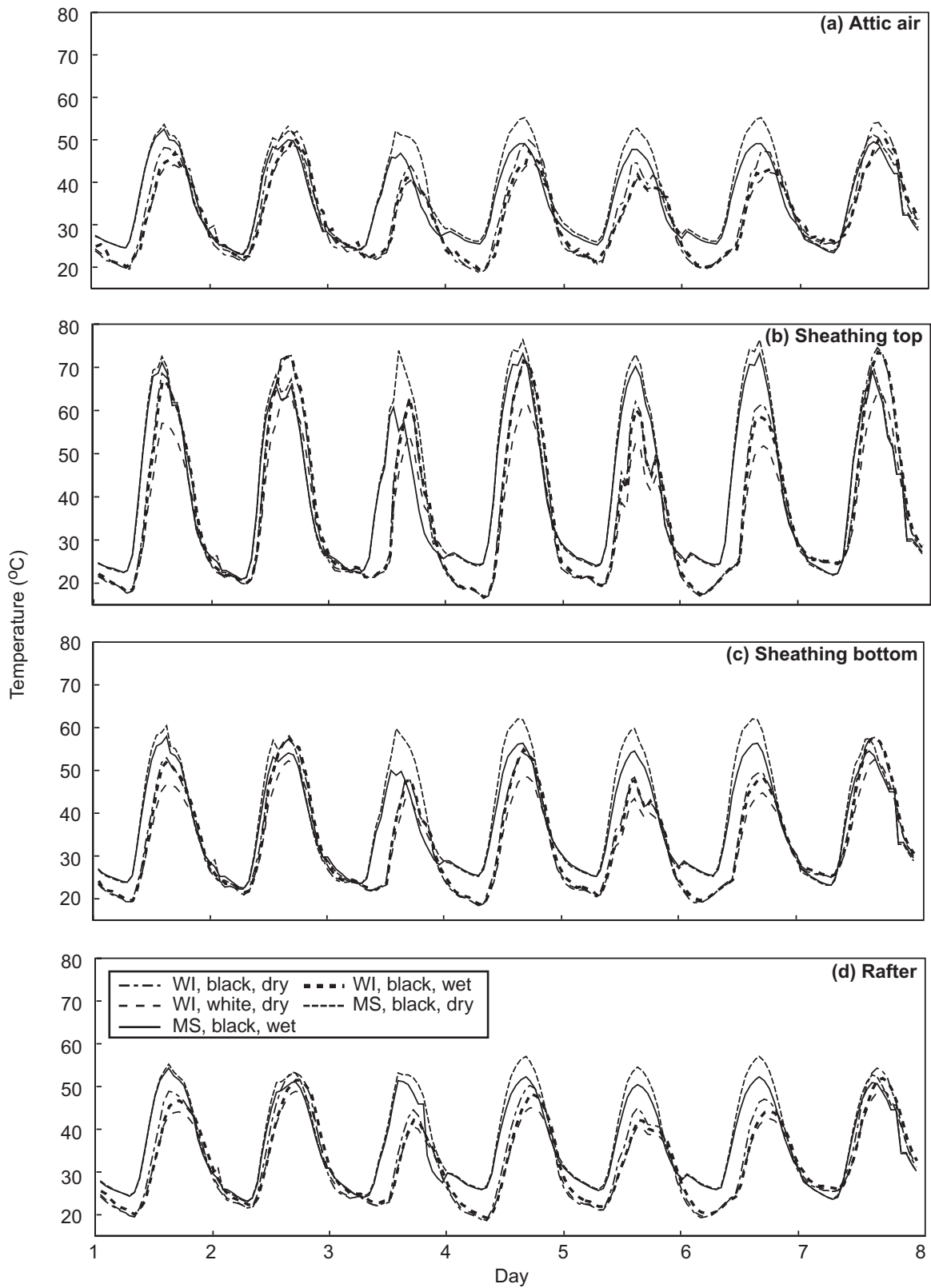

Figure 15—Influence of exposure site and attic humidity during 7 hottest consecutive days in exposure period.

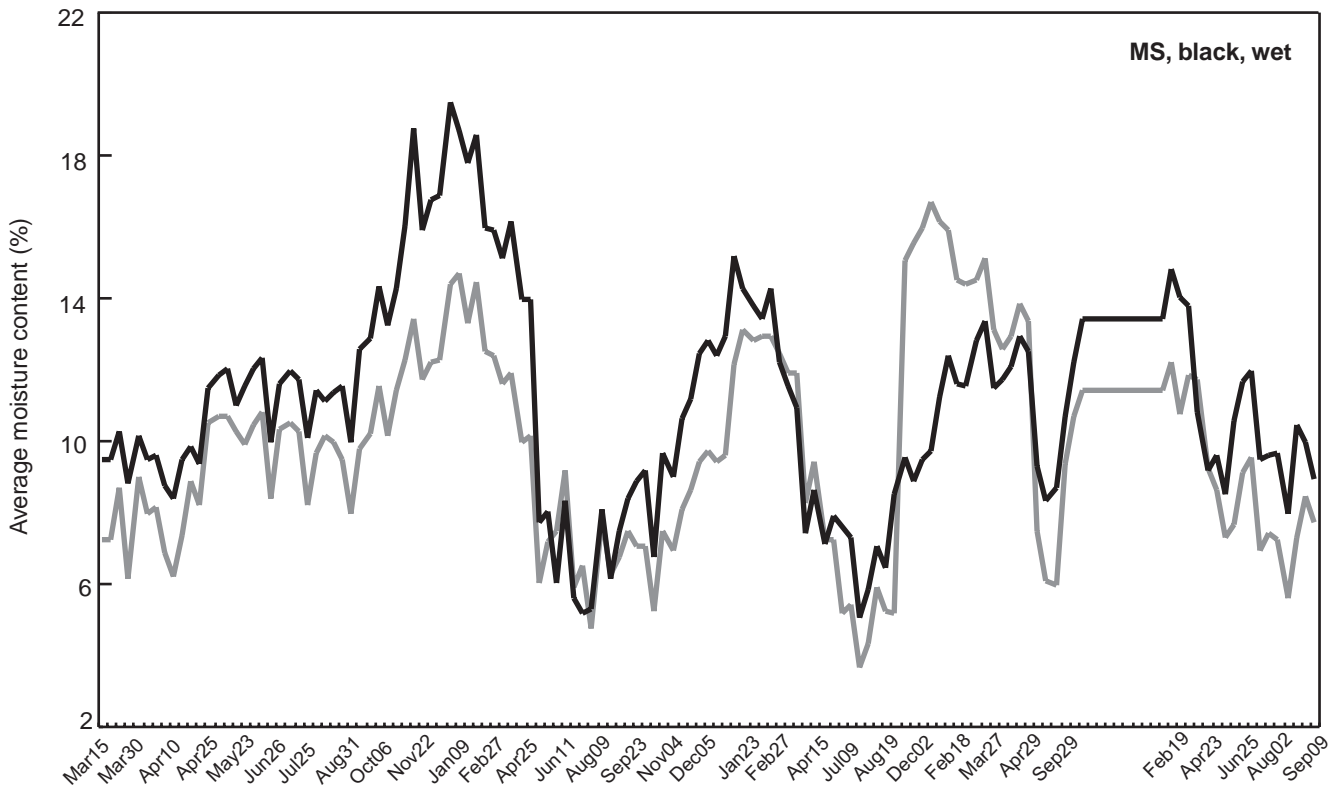
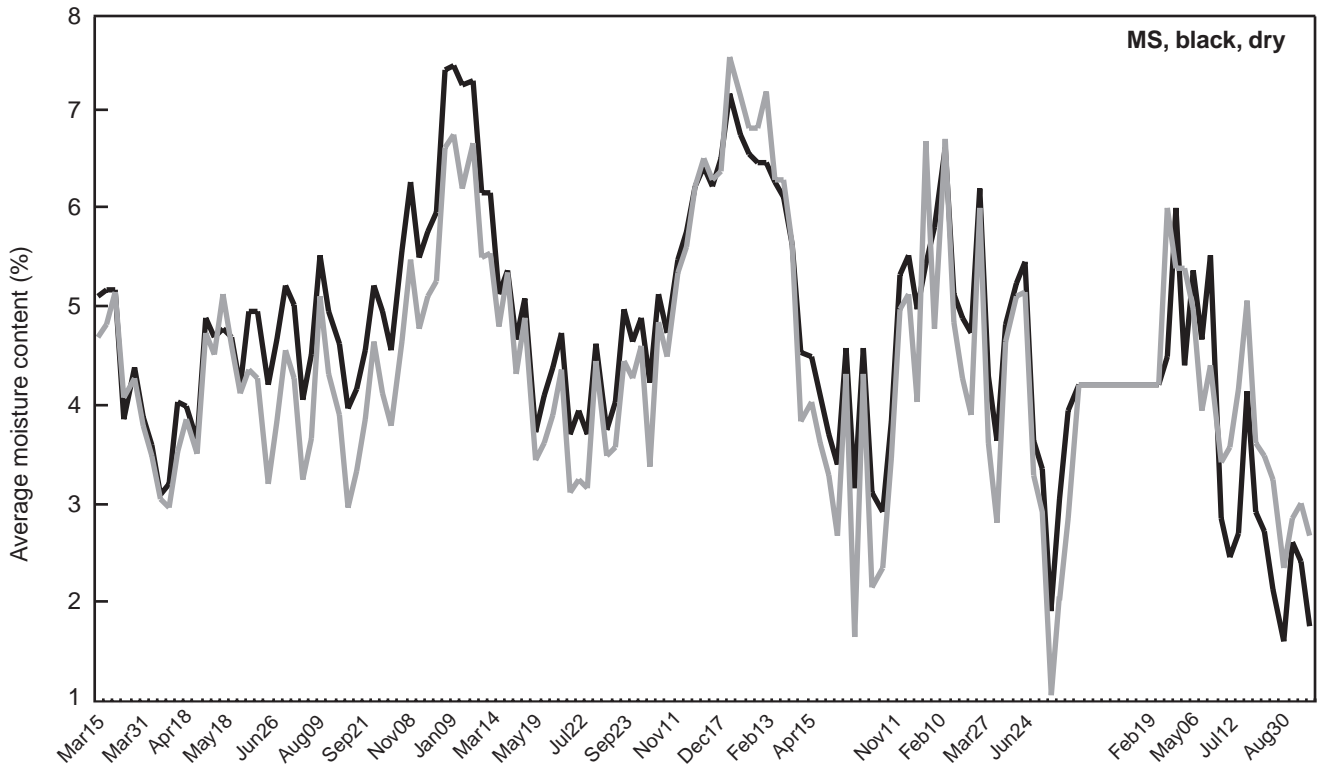

Figure 16—Moisture content history for dry and wet MS black-shingled structures.

Table 7—Duration of exposure of each test structure in high-temperature exposure ranges in current building design^a

Site	Shingle	Humidity	Sheathing or rafter location	≥37.8°C but <51.7°C	≥51.7°C but <65.6°C	≥65.6°C		
WI	Black	Dry	Top	608	302	23		
			Bottom	526	20	—		
			Rafter	389	2	—		
		Wet		Top	609	308	20	
				Bottom	537	13	—	
				Rafter	335	1	—	
		White	Dry	Top	546	73	—	
				Bottom	292	1	—	
				Rafter	190	—	—	
MS	Black	Dry	Top	932	790	234		
			Bottom	1,160	428	—		
			Rafter	1,232	122	—		
			Wet		Top	968	783	144
					Bottom	1,195	176	—
					Rafter	1,148	15	—

^aAF&PA 1997.

Acknowledgments

The authors would like to acknowledge the financial assistance of the USDA Competitive Grants program (grant no. 93–02444) and the New Jersey Department of Community Affairs. We also acknowledge the technical assistance of Louis Watson at Mississippi State University and Mike Grambsch and Earl Geske at Forest Products Laboratory, who monitored and programmed the temperature datalogging equipment. Rita Simonsen of the Forest Products Laboratory archived 8 years worth of field data. Finally, we wish to thank the CertainTeed Corporation for donation of the roofing materials used for the outdoor simulated-attic structures.

References

- AF&PA.** 1997. National design specification for wood construction. An American National Standards Institute/American Forest and Paper Association Standard. ANSI/AF&PA NDS–1997. Washington, DC: American Forest & Paper Association. 174 p.
- APA.** 1989. Fire-retardant-treated plywood: Prediction of performance. Tacoma, WA: American Plywood Association.
- ASTM.** 1988. Effect of fire retardant treatments (FRT) on the strength properties of wood. In: Minutes of workshop; 1988 April 26; Madison, WI: ASTM D7.06.04 Section: Fire performance of wood. U.S. Department of Agriculture, Forest Service, Forest Products Laboratory. 7 p.
- ASTM.** 1999. Standard practice for calculating bending strength design adjustment factors for fire-retardant-treated plywood roof sheathing. ASTM Annual Book of Standards, ASTM D6305–98. West Conshohocken, PA: American Society for Testing and Materials.
- Barnes, H.M.; Winandy, J.E.; Connors, T.E.** 1993. Laboratory/field correlations for FRT plywood. USDA National Research Initiative, competitive grant proposal for natural resources and the environment, Grant no. 93–02444. Washington, DC: U.S. Department of Agriculture, National Research Initiative.
- Blackenstowe, D.E.** 1987. Comparison of white versus black surfaces for energy conservation. In: Proceedings, 8th conference on roofing technology; 1897 April 16–17. Gaithersburg, MD: National Bureau of Standards.
- Heyer, O.C.** 1963. Study of temperature in wood parts of houses throughout the United States. Res. Note FPL–RN–012. Madison, WI: U.S. Department of Agriculture, Forest Service, Forest Products Laboratory.

Lebow, P.K.; Winandy, J.E. 1999. Verification of kinetics-based model for long-term effects of fire-retardants on bending strength at elevated temperatures. *Wood and Fiber Science*. 31(1): 49–61.

LeVan, S.L.; Collet, M. 1989. Choosing and applying fire-retardant-treated plywood and lumber for roof designs. Gen. Tech. Rep. FPL–GTR–62. Madison, WI: U.S. Department of Agriculture, Forest Service, Forest Products Laboratory. 11 p.

NAHB. 1990. Home builders guide to fire retardant treated plywood: Evaluation, testing, and replacement. Washington, DC: National Research Center of the National Association of Home Builders. 65 p.

NBS. 1979. Summer cooling and whole house ventilation. NBS special pub. 548. Reppart, M.H., ed. Gaithersburg, MD: National Bureau of Standards, U.S. Department of Commerce.

Ozkan, E. 1993. Surface and inner temperature attainment of flat roof systems in hot–dry climate. Riyadh, Saudi Arabia: King Saud University, Riyadh.

Rose, W.B. 1992. Measured values of temperature and sheathing moisture content in residential attic assemblies. In: Geshwiler, M., ed. Thermal performance of the exterior envelopes of building. In: Proceedings, ASHRAE/DOE/BTECC conference; 1992 December 1–10; Clearwater Beach, FL. Atlanta, GA: American Society of Heating, Refrigerating, and Air-Conditioning Engineers: 379–390.

Rose, W.B. 1995. Temperature and sheathing moisture content in residential attics. Unpub. rep., Champaign, IL: University of Illinois, Building Research Center.

TenWolde, A. 1988. The FPL roof temperature model. In: Effects of fire retardant treatments on strength properties of wood; Executive summary, ASTM D7 workshop; 1988 April. Madison, WI: U.S. Department of Agriculture, Forest Service, Forest Laboratory.

TenWolde, A. 1997. FPL roof temperature and moisture model. Res. Pap. FPL–RP–561. Madison, WI: U.S. Department of Agriculture, Forest Service, Forest Products Laboratory.

Wilkes, K.E. 1989. Model for roof thermal performance. Oak Ridge National Laboratory Rep. ORNL/CON–274. Oak Ridge, TN: Office of Scientific and Technical Information.

Winandy, J.E. 1998. Using kinetics-based models to address serviceability concerns for fire-retardant-treated wood at elevated in-service temperatures. In: Proceedings, 5th World conference on timber engineering; 1998 August 16–21: Montreux, Switzerland. Lausanne, Switzerland: Swiss Federal Institute of Technology.

Winandy, J.E. 2000. Serviceability modeling—Predicting and extending useful service life of FRT plywood roof sheathing. In: Proceedings, International Research Group for Wood Preservation, IRG/WP 00–20210, Stockholm, Sweden.

Winandy, J.E.; Beaumont, R. 1995. Roof temperatures in simulated attics. Res. Pap. FPL–RP–543. Madison, WI: U.S. Department of Agriculture, Forest Service, Forest Products Laboratory.

Appendix A—Exceedance Temperature Data for WI Structures

The data in Tables 8 to 27 show exceedance temperature data for field exposure structures in Madison, Wisconsin, from 1992 to 1999.

Table 8—Exceedance temperatures in WI dry, black-shingled structure, 1992

Temperature (°C)	Time (h) at given temperature at various locations				
	Structure		Roof sheathing		
	Inside	Outside	Top	Bottom	Rafter
–40	—	—	—	—	—
–35	—	—	—	—	—
–30	—	—	12	3	—
–25	32	25	32	33	35
–20	56	67	60	58	52
–15	172	183	244	196	176
–10	496	539	558	526	516
–5	1,230	1,453	1,238	1,250	1,243
0	1,589	1,714	1,485	1,542	1,565
5	1,035	961	1,023	1,023	1,036
10	1,020	1,149	977	1,020	1,030
15	1,075	1,427	935	1,017	1,032
20	772	929	559	677	752
25	467	305	369	445	487
30	374	32	292	349	379
35	310	—	258	297	314
40	135	—	204	225	142
45	21	—	204	104	25
50	—	—	158	19	—
55	—	—	103	—	—
60	—	—	61	—	—
65	—	—	12	—	—
70	—	—	—	—	—
75	—	—	—	—	—

Table 9—Exceedance temperatures in WI dry, black-shingled structure, 1993

Temperature (°C)	Time (h) at given temperature at various locations				
	Structure		Roof sheathing		
	Inside	Outside	Top	Bottom	Rafter
-40	—	—	—	—	—
-35	—	—	—	—	—
-30	—	—	3	—	—
-25	34	17	66	50	38
-20	143	152	183	154	144
-15	278	385	277	280	277
-10	592	703	642	631	603
-5	1,014	1,165	1,030	1,022	1,026
0	1,542	1,585	1,442	1,487	1,518
5	881	875	816	848	872
10	983	1,136	988	999	979
15	1,104	1,283	975	1,061	1,084
20	865	1,046	676	776	882
25	532	381	396	496	530
30	405	32	325	358	396
35	276	—	265	330	289
40	84	—	223	183	92
45	25	—	209	63	28
50	2	—	131	19	2
55	—	—	68	3	—
60	—	—	27	—	—
65	—	—	13	—	—
70	—	—	5	—	—
75	—	—	—	—	—

Table 10—Exceedance temperatures in WI dry, black-shingled structure, 1994

Temperature (°C)	Time (h) at given temperature at various locations				
	Structure		Roof sheathing		
	Inside	Outside	Top	Bottom	Rafter
-40	1	—	5	4	2
-35	27	22	35	29	29
-30	54	65	68	58	53
-25	98	124	110	110	104
-20	173	211	172	172	174
-15	268	300	305	276	263
-10	561	619	633	592	581
-5	860	914	842	860	858
0	986	1,088	999	998	984
5	1,075	1,189	998	1,035	1,065
10	1,045	1,134	1,012	1,044	1,052
15	1,223	1,528	1,059	1,164	1,198
20	832	1,007	663	765	832
25	554	486	414	505	555
30	444	69	314	388	432
35	335	4	264	334	332
40	186	—	246	260	204
45	35	—	225	132	39
50	3	—	183	31	3
55	—	—	129	3	—
60	—	—	59	—	—
65	—	—	22	—	—
70	—	—	2	—	—
75	—	—	1	—	—

Table 11—Exceedance temperatures in WI dry, black-shingled structure, 1995

Temperature (°C)	Time (h) at given temperature at various locations				
	Structure		Roof sheathing		
	Inside	Outside	Top	Bottom	Rafter
-40	—	—	—	—	—
-35	—	—	—	—	—
-30	2	—	8	5	3
-25	55	45	95	66	56
-20	204	188	250	217	204
-15	330	402	331	345	337
-10	591	828	625	604	593
-5	1,078	1,174	1,032	1,057	1062
0	1,187	1,172	1,127	1,161	1,202
5	1,032	985	980	1,016	1,019
10	902	1,000	860	897	906
15	825	1,024	839	836	819
20	923	1,109	761	827	914
25	550	635	387	537	555
30	413	187	325	343	410
35	305	11	235	315	295
40	242	—	219	244	250
45	109	—	213	199	120
50	12	—	170	78	15
55	—	—	134	13	—
60	—	—	115	—	—
65	—	—	43	—	—
70	—	—	11	—	—
75	—	—	—	—	—

Table 12—Exceedance temperatures in WI dry, black-shingled structure, 1996

Temperature (°C)	Time (h) at given temperature at various locations				
	Structure		Roof sheathing		
	Inside	Outside	Top	Bottom	Rafter
-40	2	—	6	3	3
-35	24	22	28	26	24
-30	32	44	32	31	29
-25	82	86	125	92	84
-20	235	287	256	245	236
-15	316	435	337	318	327
-10	672	712	721	702	684
-5	1,154	1,337	1,094	1,131	1,147
0	1,123	1,187	1,041	1,078	1,112
5	828	872	884	850	815
10	1,149	1,120	1,171	1,134	1,135
15	1,081	1,206	867	1,030	1,097
20	756	953	586	703	742
25	430	459	366	421	436
30	354	54	269	335	363
35	326	10	248	318	331
40	172	—	222	220	165
45	48	—	203	131	—
50	—	—	157	16	—
55	—	—	91	—	—
60	—	—	67	—	—
65	—	—	13	—	—
70	—	—	—	—	—
75	—	—	—	—	—

Table 13—Exceedance temperatures in WI dry, black-shingled structure, 1997

Temperature (°C)	Time (h) at given temperature at various locations				
	Structure		Roof sheathing		
	Inside	Outside	Top	Bottom	Rafter
-40	—	—	—	—	—
-35	—	—	—	—	—
-30	6	—	9	6	5
-25	40	53	65	46	46
-20	146	162	181	152	145
-15	229	270	255	241	235
-10	521	623	611	544	543
-5	1,213	1,385	1,185	1,216	1,218
0	1,369	1,441	1,287	1,333	1,347
5	934	837	915	909	927
10	1,025	1,146	945	1,019	1,035
15	996	1,339	989	1,005	986
20	869	1,023	605	773	842
25	496	418	372	483	498
30	384	63	317	365	388
35	304	—	252	306	295
40	181	—	225	213	197
45	41	—	192	124	47
50	6	—	158	21	6
55	—	—	117	4	—
60	—	—	57	—	—
65	—	—	18	—	—
70	—	—	5	—	—
75	—	—	—	—	—

Table 14—Exceedance temperatures in WI dry, black-shingled structure, 1998

Temperature (°C)	Time (h) at given temperature at various locations				
	Structure		Roof sheathing		
	Inside	Outside	Top	Bottom	Rafter
-40	—	—	—	—	—
-35	—	—	—	—	—
-30	—	—	3	—	—
-25	15	16	27	17	15
-20	81	75	116	91	84
-15	148	206	157	150	151
-10	380	349	427	384	380
-5	949	1,157	989	960	950
0	1,278	1,339	1,230	1,254	1,274
5	1,054	1,079	961	1,023	1,045
10	1,169	1,286	1,185	1,164	1,159
15	1,117	1,342	1,063	1,133	1,126
20	918	1,167	690	848	882
25	511	656	379	471	520
30	420	88	296	393	438
35	378	—	278	355	364
40	272	—	243	298	287
45	69	—	224	181	78
50	1	—	204	38	7
55	—	—	169	—	—
60	—	—	85	—	—
65	—	—	27	—	—
70	—	—	7	—	—
75	—	—	—	—	—

Table 15—Exceedance temperatures in WI dry, black-shingled structure, 1999

Temperature (°C)	Time (h) at given temperature at various locations				
	Structure		Roof sheathing		
	Inside	Outside	Top	Bottom	Rafter
-40	—	—	—	—	—
-35	5	2	8	6	5
-30	9	11	11	8	10
-25	31	44	49	28	28
-20	150	152	160	159	156
-15	310	330	404	329	309
-10	568	604	546	581	584
-5	1,007	1,176	1,042	1,016	993
0	1,134	1,195	1,113	1,117	1,147
5	1,054	1,119	1,009	1,029	1,033
10	980	1,079	888	960	986
15	1,080	1,228	981	1,056	1059
20	832	1,085	675	801	824
25	532	550	394	479	534
30	401	178	326	385	408
35	344	7	261	322	352
40	219	—	221	278	211
45	91	—	208	139	106
50	13	—	179	59	15
55	—	—	156	8	—
60	—	—	85	—	—
65	—	—	34	—	—
70	—	—	10	—	—
75	—	—	—	—	—

Table 16—Exceedance temperatures in WI wet, black-shingled structure, 1996

Temperature (°C)	Time (h) at given temperature at various locations				
	Structure		Roof sheathing		
	Inside	Outside	Top	Bottom	Rafter
-40	2	—	6	3	3
-35	24	22	28	26	24
-30	32	44	32	31	29
-25	82	88	124	94	85
-20	233	285	255	249	234
-15	324	433	339	317	325
-10	672	708	714	712	689
-5	1,135	1,342	1,095	1,121	1,133
0	1,129	1,191	1,037	1,067	1,113
5	817	854	849	826	791
10	1,086	1,098	1,156	1,057	1,050
15	1,128	1,199	889	1,062	1,136
20	785	913	612	740	810
25	473	468	380	449	470
30	377	123	276	340	381
35	324	16	248	311	318
40	151	—	219	232	176
45	10	—	210	135	17
50	—	—	155	12	—
55	—	—	99	—	—
60	—	—	51	—	—
65	—	—	10	—	—
70	—	—	—	—	—
75	—	—	—	—	—

Table 17—Exceedance temperatures in WI wet, black-shingled structure, 1997

Temperature (°C)	Time (h) at given temperature at various locations				
	Structure		Roof sheathing		Rafter
	Inside	Outside	Top	Bottom	
-40	—	—	—	—	—
-35	—	—	—	—	—
-30	5	—	9	6	4
-25	44	52	57	47	44
-20	138	163	173	160	142
-15	240	266	266	246	237
-10	529	613	589	558	522
-5	1,188	1,406	1,211	1,224	1,235
0	1,377	1,428	1,265	1,301	1,348
5	915	823	886	870	879
10	977	1,143	955	983	952
15	1,030	1,364	975	966	971
20	940	1,033	642	825	977
25	598	414	411	532	582
30	425	55	302	386	437
35	258	—	265	319	288
40	87	—	216	209	128
45	9	—	199	110	14
50	—	—	163	16	—
55	—	—	104	2	—
60	—	—	56	—	—
65	—	—	12	—	—
70	—	—	4	—	—
75	—	—	—	—	—

Table 19—Exceedance temperatures in WI wet, black-shingled structure, 1999

Temperature (°C)	Time (h) at given temperature at various locations				
	Structure		Roof sheathing		Rafter
	Inside	Outside	Top	Bottom	
-40	—	—	—	—	—
-35	5	2	8	7	6
-30	9	11	11	8	9
-25	29	40	38	31	27
-20	100	123	99	101	103
-15	248	229	326	268	243
-10	522	542	536	565	543
-5	975	1,154	1,009	955	949
0	1,255	1,440	1,199	1,221	1,255
5	1,091	1,090	1,047	1,077	1,088
10	1,015	1,127	929	988	1,012
15	1,067	1,220	976	1,005	1,028
20	915	1,093	695	845	895
25	598	507	416	529	586
30	430	172	337	374	431
35	318	10	265	320	349
40	145	—	218	269	171
45	34	—	212	135	58
50	4	—	182	53	7
55	—	—	140	9	—
60	—	—	73	—	—
65	—	—	36	—	—
70	—	—	8	—	—
75	—	—	—	—	—

Table 18—Exceedance temperatures in WI wet, black-shingled structure, 1998

Temperature (°C)	Time (h) at given temperature at various locations				
	Structure		Roof sheathing		Rafter
	Inside	Outside	Top	Bottom	
-40	—	—	—	—	—
-35	—	—	—	—	—
-30	—	—	3	1	—
-25	16	15	25	21	15
-20	82	74	113	93	89
-15	146	201	155	154	149
-10	369	353	431	386	373
-5	992	1,141	1,010	984	961
0	1,224	1,350	1,197	1,244	1,267
5	1,020	1,066	958	994	1,014
10	1,147	1,289	1,165	1,125	1,116
15	1,136	1,345	1,072	1,119	1,107
20	1,005	1,242	723	886	980
25	592	614	394	493	602
30	464	70	307	430	463
35	400	—	268	335	404
40	154	—	266	311	203
45	13	—	216	162	17
50	—	—	187	22	—
55	—	—	167	—	—
60	—	—	78	—	—
65	—	—	22	—	—
70	—	—	3	—	—
75	—	—	—	—	—

Table 20—Exceedance temperatures in WI dry, white-shingled structure, 1992

Temperature (°C)	Time (h) at given temperature at various locations				
	Structure		Roof sheathing		Rafter
	Inside	Outside	Top	Bottom	
-40	—	—	—	—	—
-35	—	—	—	—	—
-30	—	—	12	2	—
-25	31	25	36	34	35
-20	54	66	64	59	53
-15	168	184	249	200	175
-10	504	538	574	538	524
-5	1,271	1,437	1,284	1,281	1,283
0	1,622	1,713	1,532	1,585	1,603
5	1,035	976	1,059	1,047	1,038
10	1,037	1,149	1,019	1,057	1,059
15	1,124	1,407	976	1,058	1,110
20	793	937	615	742	772
25	505	316	382	444	477
30	409	36	303	379	412
35	199	—	267	256	206
40	32	—	210	89	37
45	—	—	135	13	—
50	—	—	59	—	—
55	—	—	8	—	—
60	—	—	—	—	—
65	—	—	—	—	—
70	—	—	—	—	—
75	—	—	—	—	—

Table 21—Exceedance temperatures in WI dry, white-shingled structure, 1993

Temperature (°C)	Time (h) at given temperature at various locations				
	Structure		Roof sheathing		
	Inside	Outside	Top	Bottom	Rafter
-40	—	—	—	—	—
-35	—	—	—	—	—
-30	—	—	4	—	—
-25	33	19	69	47	39
-20	142	147	187	160	146
-15	278	378	288	281	280
-10	616	703	662	659	627
-5	1,054	1,179	1,114	1,074	1,063
0	1,558	1,567	1,460	1,534	1,544
5	878	882	839	860	877
10	1,023	1,119	1,029	1,034	1,039
15	1,116	1,274	1,030	1,066	1,110
20	919	1,066	714	848	892
25	528	389	414	497	526
30	411	37	335	387	403
35	161	—	274	226	171
40	41	—	199	70	40
45	2	—	95	16	3
50	—	—	31	1	—
55	—	—	13	—	—
60	—	—	3	—	—
65	—	—	—	—	—
70	—	—	—	—	—
75	—	—	—	—	—

Table 22—Exceedance temperatures in WI dry, white-shingled structure, 1994

Temperature (°C)	Time (h) at given temperature at various locations				
	Structure		Roof sheathing		
	Inside	Outside	Top	Bottom	Rafter
-40	—	—	5	4	2
-35	27	22	36	30	29
-30	54	64	66	57	53
-25	96	122	115	111	104
-20	179	209	182	175	179
-15	263	299	316	276	266
-10	578	628	641	620	598
-5	870	902	907	901	874
0	1,021	1,095	1,026	1,021	1,039
5	1,095	1,178	1,037	1,059	1,067
10	1,075	1,147	1,066	1,087	1,077
15	1,273	1,501	1,129	1,223	1,251
20	859	1,024	683	790	844
25	595	496	439	527	584
30	446	70	328	421	449
35	272	3	289	293	277
40	53	—	246	141	61
45	4	—	165	22	6
50	—	—	70	2	—
55	—	—	12	—	—
60	—	—	2	—	—
65	—	—	—	—	—
70	—	—	—	—	—
75	—	—	—	—	—

Table 23—Exceedance temperatures in WI dry, white-shingled structure, 1995

Temperature (°C)	Time (h) at given temperature at various locations				
	Structure		Roof sheathing		
	Inside	Outside	Top	Bottom	Rafter
-40	—	—	—	—	—
-35	—	—	—	—	—
-30	2	—	8	5	3
-25	55	45	102	66	56
-20	199	196	257	224	207
-15	335	397	336	350	336
-10	607	793	658	620	622
-5	1,096	1,201	1,085	1,098	1,094
0	1,217	1,177	1,178	1,206	1,232
5	1,034	985	990	1,036	1028
10	919	1,006	887	893	894
15	849	997	865	855	853
20	957	1,103	760	899	955
25	593	642	464	522	569
30	424	208	307	392	420
35	301	10	278	279	289
40	151	—	233	230	172
45	21	—	164	81	30
50	—	—	130	4	—
55	—	—	47	—	—
60	—	—	11	—	—
65	—	—	—	—	—
70	—	—	—	—	—
75	—	—	—	—	—

Table 24—Exceedance temperatures in WI dry, white-shingled structure, 1996

Temperature (°C)	Time (h) at given temperature at various locations				
	Structure		Roof sheathing		
	Inside	Outside	Top	Bottom	Rafter
-40	2	—	9	4	3
-35	24	22	27	25	23
-30	25	42	31	31	31
-25	87	85	132	92	86
-20	229	278	264	258	237
-15	331	412	348	330	334
-10	693	682	766	721	706
-5	1,162	1,271	1,129	1,168	1,167
0	1,133	1,126	1,063	1,105	1,135
5	846	921	886	849	832
10	1,157	1,239	1,204	1,199	1,152
15	1,127	1,192	917	1,045	1,121
20	775	996	640	736	759
25	460	472	359	412	456
30	420	46	302	370	433
35	264	—	240	280	255
40	49	—	223	148	54
45	—	—	147	11	—
50	—	—	79	—	—
55	—	—	18	—	—
60	—	—	—	—	—
65	—	—	—	—	—
70	—	—	—	—	—
75	—	—	—	—	—

Table 25—Exceedance temperatures in WI dry, white-shingled structure, 1997

Temperature (°C)	Time (h) at given temperature at various locations				
	Structure		Roof sheathing		
	Inside	Outside	Top	Bottom	Rafter
-40	—	—	—	—	—
-35	—	—	—	—	—
-30	4	1	10	6	5
-25	42	51	57	48	43
-20	138	165	184	156	146
-15	234	255	266	253	237
-10	533	616	603	551	537
-5	1,219	1,409	1,255	1,253	1,244
0	1,412	1,429	1,339	1,393	1,409
5	942	827	936	931	923
10	1,008	1,139	1,012	1,018	1,005
15	1,072	1,324	964	1,015	1,048
20	927	1,042	707	841	913
25	524	433	404	482	533
30	405	69	305	389	404
35	246	—	259	269	251
40	48	—	200	134	54
45	6	—	160	17	8
50	—	—	79	4	—
55	—	—	15	—	—
60	—	—	5	—	—
65	—	—	—	—	—
70	—	—	—	—	—
75	—	—	—	—	—

Table 26—Exceedance temperatures in WI dry, white-shingled structure, 1998

Temperature (°C)	Time (h) at given temperature at various locations				
	Structure		Roof sheathing		
	Inside	Outside	Top	Bottom	Rafter
-40	—	—	—	—	—
-35	—	—	—	—	—
-30	—	—	3	—	—
-25	15	13	27	16	14
-20	63	74	112	79	74
-15	145	202	160	161	154
-10	336	357	445	385	370
-5	930	1,126	1,033	978	947
0	1,331	1,376	1,272	1,304	1,329
5	1,045	1,063	1,008	1,046	1,050
10	1,203	1,295	1,190	1,205	1,210
15	1,180	1,314	1,120	1,155	1,129
20	998	1,209	748	895	959
25	578	640	380	511	585
30	465	91	337	424	451
35	387	—	296	362	386
40	83	—	269	211	99
45	1	—	220	28	3
50	—	—	107	—	—
55	—	—	28	—	—
60	—	—	5	—	—
65	—	—	—	—	—
70	—	—	—	—	—
75	—	—	—	—	—

Table 27—Exceedance temperatures in WI dry, white-shingled structure, 1999

Temperature (°C)	Time (h) at given temperature at various locations				
	Structure		Roof sheathing		
	Inside	Outside	Top	Bottom	Rafter
-40	—	—	—	—	—
-35	3	2	8	5	4
-30	8	12	10	9	8
-25	20	37	50	23	22
-20	140	150	168	162	156
-15	311	339	408	336	312
-10	604	598	565	607	604
-5	990	1,176	1,080	1,021	1,008
0	1,171	1,184	1,111	1,152	1,168
5	1,065	1,137	1,050	1,048	1,079
10	1,043	1,067	950	1,006	1,019
15	1,072	1,218	1,023	1,069	1,068
20	874	1,111	731	815	846
25	584	547	420	528	575
30	443	174	323	413	440
35	295	8	266	333	296
40	126	—	239	163	140
45	11	—	199	62	15
50	—	—	106	8	—
55	—	—	42	—	—
60	—	—	11	—	—
65	—	—	—	—	—
70	—	—	—	—	—
75	—	—	—	—	—

Appendix B—Exceedance Temperature Data for MS Structures

The data in the following tables (Tables 28 to 35) show exceedance temperature data for field exposure structures in Starkville, Mississippi, from 1996 to 1999.

Table 28—Exceedance temperatures in MS dry, black-shingled structure, 1996

Temperature (°C)	Time (h) at given temperature at various locations				
	Structure		Roof sheathing		
	Inside	Outside	Top	Bottom	Rafter
-40	—	—	—	—	—
-35	—	—	—	—	—
-30	—	—	—	—	—
-25	—	—	—	—	—
-20	5	3	17	12	7
-15	22	39	58	20	23
-10	99	153	148	118	100
-5	234	351	335	295	254
0	576	596	593	564	560
5	818	996	780	797	805
10	1,056	1,183	1,043	1,034	1,035
15	1,155	1,382	1,206	1,118	1,147
20	1,717	2,085	1,456	1,657	1,700
25	1,008	1,119	638	828	980
30	610	710	438	574	598
35	483	167	327	422	476
40	488	—	363	406	456
45	415	—	317	401	428
50	98	—	257	348	212
55	—	—	315	188	3
60	—	—	243	2	—
65	—	—	202	—	—
70	—	—	48	—	—
75	—	—	—	—	—

Table 29—Exceedance temperatures in MS dry, black-shingled structure, 1997

Temperature (°C)	Time (h) at given temperature at various locations				
	Structure		Roof sheathing		
	Inside	Outside	Top	Bottom	Rafter
-40	—	—	—	—	—
-35	—	—	—	—	—
-30	—	—	—	—	—
-25	—	—	—	—	—
-20	—	—	1	—	—
-15	13	5	33	19	14
-10	61	61	109	79	63
-5	182	214	314	228	196
0	640	733	728	668	625
5	983	1,147	929	952	970
10	1,095	1,327	1,081	1,069	1,096
15	1,223	1,543	1,144	1,170	1,200
20	1,500	1,854	1,348	1,439	1,466
25	1,045	1,121	603	817	999
30	611	674	399	542	626
35	492	81	338	515	493
40	482	—	334	383	457
45	342	—	356	405	387
50	91	—	275	314	167
55	—	—	287	157	1
60	—	—	260	3	—
65	—	—	184	—	—
70	—	—	37	—	—
75	—	—	—	—	—

Table 30—Exceedance temperatures in MS dry, black-shingled structure, 1998

Temperature (°C)	Time (h) at given temperature at various locations				
	Structure		Roof sheathing		
	Inside	Outside	Top	Bottom	Rafter
-40	—	—	—	—	—
-35	—	—	—	—	—
-30	—	—	—	—	—
-25	—	—	—	—	—
-20	—	—	—	—	—
-15	—	—	2	—	—
-10	20	7	86	34	22
-5	206	228	324	266	217
0	539	554	653	561	535
5	947	1,179	877	917	939
10	1,013	1,210	958	991	996
15	1,026	1,258	1,070	981	1,008
20	1,554	1,815	1,457	1,543	1,526
25	1,146	1,299	670	907	1,092
30	652	962	394	582	674
35	479	248	371	499	500
40	530	—	323	394	466
45	465	—	363	432	506
50	181	—	292	405	268
55	2	—	327	230	11
60	—	—	315	18	—
65	—	—	191	—	—
70	—	—	85	—	—
75	—	—	2	—	—

Table 31—Exceedance temperatures in MS dry, black-shingled structure, 1999

Temperature (°C)	Time (h) at given temperature at various locations				
	Structure		Roof sheathing		
	Inside	Outside	Top	Bottom	Rafter
-40	—	—	—	—	—
-35	—	—	—	—	—
-30	—	—	—	—	—
-25	—	—	—	—	—
-20	—	—	12	4	—
-15	17	11	21	20	16
-10	40	39	83	55	43
-5	185	177	352	242	191
0	453	482	463	453	454
5	778	999	840	796	765
10	1,147	1,373	1,088	1,097	1,101
15	1,194	1,510	1,215	1,161	1,199
20	1,611	1,944	1,332	1,487	1,558
25	1,079	1,234	651	911	1,074
30	684	784	453	624	688
35	522	207	383	493	503
40	527	—	372	413	485
45	370	—	317	432	457
50	148	—	311	358	196
55	5	—	309	186	30
60	—	—	270	28	—
65	—	—	198	—	—
70	—	—	84	—	—
75	—	—	6	—	—

Table 32—Exceedance temperatures in MS wet, black-shingled structure, 1996

Temperature (°C)	Time (h) at given temperature at various locations				
	Structure		Roof sheathing		
	Inside	Outside	Top	Bottom	Rafter
-40	—	—	—	—	—
-35	—	—	—	—	—
-30	—	—	—	—	—
-25	—	—	—	—	—
-20	—	3	12	3	—
-15	20	39	18	21	22
-10	40	153	157	73	47
-5	286	351	358	306	290
0	647	596	596	620	613
5	860	996	810	810	811
10	1,122	1,183	1,012	1,031	1,072
15	1,180	1,382	1,176	1,120	1,150
20	1,780	2,085	1,493	1,684	1,740
25	923	1,119	681	901	996
30	568	710	479	618	609
35	542	167	331	435	507
40	453	—	363	452	470
45	350	—	303	404	387
50	13	—	304	290	70
55	—	—	286	16	—
60	—	—	250	—	—
65	—	—	146	—	—
70	—	—	9	—	—
75	—	—	—	—	—

Table 33—Exceedance temperatures in MS wet black-shingled structure, 1997

Temperature (°C)	Time (h) at given temperature at various locations				
	Structure		Roof sheathing		
	Inside	Outside	Top	Bottom	Rafter
-40	—	—	—	—	—
-35	—	—	—	—	—
-30	—	—	—	—	—
-25	—	—	—	—	—
-20	—	—	—	—	—
-15	3	5	22	11	3
-10	29	61	106	43	33
-5	211	214	289	234	207
0	671	733	705	652	637
5	994	1,147	936	956	988
10	1,157	1,327	1,078	1,083	1,114
15	1,258	1,543	1,169	1,199	1,210
20	1,540	1,854	1,369	1,478	1,547
25	1,025	1,121	644	914	1,048
30	612	674	418	611	622
35	524	81	375	476	484
40	441	—	359	449	471
45	275	—	328	388	316
50	20	—	273	244	80
55	—	—	309	22	—
60	—	—	248	—	—
65	—	—	127	—	—
70	—	—	5	—	—
75	—	—	—	—	—

Table 34—Exceedance temperatures in MS wet, black-shingled structure, 1998

Temperature (°C)	Time (h) at given temperature at various locations				
	Structure		Roof sheathing		
	Inside	Outside	Top	Bottom	Rafter
-40	—	—	—	—	—
-35	—	—	—	—	—
-30	—	—	—	—	—
-25	—	—	—	—	—
-20	—	—	—	—	—
-15	—	—	—	—	—
-10	—	7	57	3	—
-5	221	228	313	248	212
0	543	554	624	551	519
5	973	1,179	906	917	939
10	1,070	1,210	942	1,014	1,038
15	1,064	1,258	1,061	983	1,063
20	1,697	1,815	1,484	1,588	1,580
25	1,085	1,299	722	1,009	1,150
30	644	962	437	673	680
35	550	248	392	471	537
40	546	—	371	482	549
45	346	—	316	494	388
50	21	—	330	297	105
55	—	—	350	30	—
60	—	—	258	—	—
65	—	—	171	—	—
70	—	—	26	—	—
75	—	—	—	—	—

Table 35—Exceedance temperatures in MS wet, black-shingled structure, 1999

Temperature (°C)	Time (h) at given temperature at various locations				
	Structure		Roof sheathing		
	Inside	Outside	Top	Bottom	Rafter
-40	—	—	—	—	—
-35	—	—	—	—	—
-30	—	—	—	—	—
-25	—	—	—	—	—
-20	—	—	7	—	—
-15	8	11	17	13	10
-10	21	39	66	25	23
-5	196	177	305	227	218
0	452	482	477	450	466
5	831	999	832	786	811
10	1,169	1,373	1,095	1,102	1,091
15	1,349	1,510	1,232	1,219	1,252
20	1,728	1,944	1,355	1,573	1,661
25	1,077	1,234	698	1,021	1,100
30	677	784	490	683	697
35	610	207	415	511	569
40	479	—	369	502	540
45	162	—	349	434	265
50	1	—	341	193	57
55	—	—	301	21	—
60	—	—	245	—	—
65	—	—	135	—	—
70	—	—	31	—	—
75	—	—	—	—	—