Mortars



U.S. Marine Corps

PREFACE

This publication prescribes guidance for leaders and crewmen of mortar squads and platoons. It is concerned with the problems of mortar crew training. It presents practical solutions to assist in the timely delivery of accurate mortar fires but does not discuss all possible situations. Local requirements may dictate minor variations from the methods and techniques described herein. However, principles should not be violated by modification of techniques and methods.

The scope of this publication includes mortar crew training at squad and section levels. The 60-mm mortar, M224; 81-mm mortar, M29A1; 81-mm mortar, M252; 4.2-inch (107-mm) mortar, M30; and 120-mm mortar, M120, are discussed herein to include nomenclature, sighting, equipment, characteristics, capabilities, ammunition, and maintenance.

Note: For clarity and simplicity, the artwork in this manual does not show soldiers in BDUs. The words and required art detail cannot be seen due to the camouflage on BDUs.

The provisions of this publication are the subject of international agreements:

QSTAG 900	Characteristics of a Multirole Mortar Fuze (Edition One)
STANAG 2321	NATO Code of Colors for the Identification of Ammunition (Except Ammunition of a Caliber Below 22 millimeters)

The proponent of this manual is HQ TRADOC. Submit changes for improving this publication on DA Form 2028 (Recommended Changes to Publications and Blank Forms) and forward it to US Army Infantry School, ATTN: ATSH-INB-O, Fort Benning, GA 31905-5594.

Unless otherwise stated, whenever the masculine gender is used, both men and women are included.

FM 23-90
TECHNICAL ORDER 11W2-5-13-21
1 MARCH 2000

By Order of the Secretary of the Army:

ERIC K. SHINSEKI
General, United States
Army
Chief of Staff

Official:

JOEL B. HUDSON
Administrative Assistant to
the
Secretary of the Army
0000505

DISTRIBUTION: *Active Army, Army National Guard, and U.S. Army Reserve:* To be distributed in accordance with the initial distribution number 110209, requirements for FM 23-90.

**FIELD MANUAL
NO. 23-90
TECHNICAL ORDER
NO. 11W2-5-13-21**

**HEADQUARTERS
DEPARTMENT OF THE ARMY
AND THE AIR FORCE
WASHINGTON, DC, 1 March 2000**

<p>FM 23-90 MCRP 3-15.2A</p>
<p>MORTARS</p>

Table of Contents

PREFACE

CHAPTER 1 INTRODUCTION

- Section I General Doctrine
- 1-1. Effective Mortar Fire
 - 1-2. Mortar Positions
- Section II Indirect Fire Team
- 1-3. Applications
 - 1-4. Team Mission
- Section III Safety Procedures
- 1-5. Duties of the Safety Officer and Supervisory Personnel
 - 1-6. Ammunition Care and Handling
 - 1-7. Field Storage of Ammunition

CHAPTER 2 SIGHTING AND FIRE CONTROL EQUIPMENT

- Section I Compass, M2
- 2-1. Characteristics
 - 2-2. Description
 - 2-3. Use
- Section II Aiming Circles, M2 and M2A2

- 2-4. Characteristics
- 2-5. Description
- 2-6. Use
- 2-7. Accessory Equipment
- 2-8. Setup and Leveling of Aiming Circle
- 2-9. Declination Constant
- 2-10. Orienting of the Instrument on Grid North to Measure Grid Azimuth to Objects
- 2-11. Measurement of Horizontal Angle Between Two Points
- 2-12. Orienting of the 0-3200 Line on a Given Grid Azimuth
- 2-13. Orienting of the 0-3200 Line on a Given Magnetic Azimuth
- 2-14. Verifying the Lay of the Platoon
- 2-15. Orienting by Orienting Angle
- 2-16. Disassembly of Aiming Circle
- 2-17. Care and Maintenance
- Section III Sightunits
 - 2-18. Sightunit, M53-Series
 - 2-19. Operation of M53 Sightunit
 - 2-20. Care and Maintenance of M53 Sightunit
 - 2-21. Sightunit, M64-Series
 - 2-22. Sightunit, M67
- Section IV Boresights
 - 2-23. Boresight, M45-Series
 - 2-24. Boresight, M115
 - 2-25. Principles of Operation
 - 2-26. Installation
 - 2-27. Sight Calibration
 - 2-28. Boresight Method of Calibration
 - 2-29. Calibration for Deflection Using the M2 Aiming Circle
- Section V Other Equipment
 - 2-30. Instrument Light, M53E1
 - 2-31. Aiming Posts, M14 and M1A2
 - 2-32. Aiming Post Lights, M58 and M59
- Section VI Laying the Section
 - 2-33. Reciprocal Laying

		2-34. Reciprocal Laying on a Grid Azimuth
		2-35. Reciprocal Laying on a Magnetic Azimuth
		2-36. Reciprocal Laying Using the Orienting Angle
		2-37. Reciprocal Laying Using the Mortar Sights
		2-38. Reciprocal Laying Using the M2 Compass
		2-39. Placing Out Aiming Posts
		2-40. Alternate Method of Placing Out Aiming Posts
		2-41. Correction for Displacement of Sight
Section	VII	Loading and Firing
		2-42. Firing the Mortar
		2-43. Target Engagement
		2-44. Execution of Fire Commands
		2-45. Arm-and-Hand Signals
		2-46. Subsequent Fire Commands
		2-47. Repeating and Correcting of Fire Commands
		2-48. Reporting of Errors in Firing
		2-49. Night Firing
CHAPTER 3 60-mm MORTAR, M224		
Section	I	Squad and Section Organization and Duties
		3-1. Organization
		3-2. Duties
Section	II	Components
		3-3. Tabulated Data
		3-4. Cannon Assembly, M225
		3-5. Baseplate, M7
		3-6. Baseplate, M8
		3-7. Bipod Assembly, M170
Section	III	Operation
		3-8. Premount Checks
		3-9. Mounting of the Mortar
		3-10. Safety Checks Before Firing
		3-11. Small Deflection and Elevation Changes
		3-12. Large Deflection and Elevation Changes
		3-13. Referring of the Sight and Realignment of Aiming Posts
		3-14. Malfunctions

		3-15. Removal of a Misfire
		3-16. Dismounting and Carrying of the Mortar
Section	IV	Ammunition
		3-17. Classification
		3-18. Color Codes
		3-19. Preparation of Ammunition
		3-20. Types of Fuzes
		3-21. Standard B Ammunition
		3-22. Care and Handling
CHAPTER 4 81-mm MORTAR, M252		
Section	I	Squad and Section Organization and Duties
		4-1. Organization
		4-2. Duties
Section	II	Components
		4-3. Tabulated Data
		4-4. Cannon Assembly, M253
		4-5. Mount, M177
		4-6. Baseplate, M3A1
Section	III	Operation
		4-7. Premount Checks
		4-8. Mounting of the Mortar
		4-9. Safety Checks Before Firing
		4-10. Small Deflection and Elevation Changes
		4-11. Large Deflection and Elevation Changes
		4-12. Referring of the Sight and Realignment of Aiming Posts Using M64 Sight
		4-13. Malfunctions
		4-14. Removal of a Misfire
		4-15. Dismounting of the Mortar
Section	IV	Ammunition
		4-16. Classification
		4-17. Function
		4-18. High-Explosive Ammunition
		4-19. Red/White Phosphorus Ammunition
		4-20. Illuminating Ammunition

- 4-21. Types of Fuzes
- 4-22. Characteristics of Proximity Fuzes
- 4-23. Fuze Wrench and Fuze Setter
- 4-24. Preparation of Ammunition
- 4-25. Care and Handling

CHAPTER 5 81-mm MORTAR, M29A1

- Section I Squad and Section Organization and Duties
 - 5-1. Organization
 - 5-2. Duties
- Section II Components
 - 5-3. Tabulated Data
 - 5-4. Cannon Assembly, M29A1
 - 5-5. Bipod Assembly, M23A1
 - 5-6. Baseplate, M3
- Section III Operation
 - 5-7. Premount Checks
 - 5-8. Mounting of the Mortar
 - 5-9. Safety Checks Before Firing
 - 5-10. Small Deflection and Elevation Changes
 - 5-11. Large Deflection and Elevation Changes
 - 5-12. Referring of the Sight and Realignment of Aiming Posts Using M53 Sight
 - 5-13. Malfunctions
 - 5-14. Removal of a Misfire
 - 5-15. Dismounting of the Mortar
- Section IV Ammunition
 - 5-16. Function
 - 5-17. High-Explosive Ammunition
 - 5-18. White Phosphorus Ammunition
 - 5-19. White Phosphorus Ammunition
 - 5-20. Types of Fuzes
 - 5-21. Characteristics of Proximity Fuzes
 - 5-22. Fuze Wrench and Fuze Setter
 - 5-23. Preparation of Ammunition
 - 5-24. Care and Handling

CHAPTER 6 4.2-INCH MORTAR, M30

- Section I Squad and Section Organization and Duties
 - 6-1. Organization
 - 6-2. Duties
 - 6-3. Section Drill and Section Leader Duties
- Section II Components
 - 6-4. Tabulated Data
 - 6-5. Mortar Cannon, M30
 - 6-6. Mortar Mount, M24A1
- Section III Operation of Ground-Mounted Mortar
 - 6-7. Mounting of the Mortar
 - 6-8. Safety Checks Before Firing
 - 6-9. Small Deflection Change
 - 6-10. Large Deflection and Elevation Changes
 - 6-11. Loading and Firing of M329A2 Round
 - 6-12. Malfunctions
 - 6-13. Removal of a Misfire
 - 6-14. Dismounting of the Mortar
- Section IV Mortar Carriers, M106, M106A1, and M106A2
 - 6-15. Description
 - 6-16. Tabulated Data
- Section V Operation of Carrier-Mounted Mortar
 - 6-17. Mortar and Vehicular Mount
 - 6-18. Maintenance
 - 6-19. Placement of Mortar Into Firing Position on Carrier
 - 6-20. Laying for Deflection and Elevation
 - 6-21. Removal of a Misfire (Carrier-Mounted)
 - 6-22. Mounting of Mortar on Carrier From Ground-Mounted Position
 - 6-23. Dismounting of Mortar From Carrier
 - 6-24. Preparation for a March Order From Ground-Mounted Position
 - 6-25. Safety Checks
 - 6-26. Measurement of Minimum and Maximum Elevations
 - 6-27. Squad Formations
 - 6-28. Dismounted Mortar Squad

		6-29. Reciprocally Laying the Mortar Carrier Section
Section	VI	Ammunition
		6-30. Classification
		6-31. Types of Fuzes
		6-32. Preparation of Ammunition
		6-33. Care and Handling
CHAPTER 7 120-mm MORTAR, M120		
Section	I	Squad and Section Organization and Duties
		7-1. Organization
		7-2. Duties
Section	II	Components
		7-3. Tabulated Data for the 120-mm Mortar, M120
		7-4. Barrel Assembly, M298
		7-5. Bipod Assembly, M191 (Carrier-/Ground-Mounted)
		7-6. Bipod Assembly, M190 (Ground-Mounted)
		7-7. Baseplate, M9
Section	III	Operations
		7-8. Placing a Ground-Mounted 120-mm Mortar Into Action
		7-9. Performing Safety Checks on a Ground-Mounted 120-mm Mortar
		7-10. Performing Small Deflection and Elevation Changes on a Ground-Mounted 120-mm Mortar
		7-11. Performing Large Deflection and Elevation Changes on a Ground-Mounted 120-mm Mortar
		7-12. Malfunctions on a Ground-Mounted 120-mm Mortar
		7-13. Performing Misfire Procedures on a Ground-Mounted 120-mm Mortar During Combat
		7-14. Loading and Firing the Ground-Mounted 120-mm Mortar
		7-15. Taking the 120-mm Mortar Out of Action
Section	IV	Mortar Carrier, M1064A3
		7-16. Description
		7-17. Tabulated Data for the M1064A3 Carrier
Section	V	Operation of a Carrier-Mounted 120-mm Mortar
		7-18. Mortar and Vehicular Mount
		7-19. Maintenance
		7-20. Placing Carrier-Mounted 120-mm Mortar Into Action

- 7-21. Lay for Deflection and Elevation on a Carrier-Mounted 120-mm Mortar
 - 7-22. Performing Misfire Procedures on a Carrier-Mounted 120-mm Mortar During Combat
 - 7-23. Mounting of the Mortar From a Carrier to a Ground-Mounted Position
 - 7-24. Taking the Mortar Out of Action (Ground-Mounted to M1064A3 Carrier-Mounted)
 - 7-25. Performing Safety Checks on a Carrier-Mounted 120-mm Mortar
 - 7-26. Reciprocally Laying the Mortar Carrier Section
- Section VI Ammunition
- 7-27. Classification
 - 7-28. Authorized Cartridges
 - 7-29. Preparation for Firing
 - 7-30. Loading and Firing
 - 7-31. Unfired Cartridges
 - 7-32. Care and Handling of Cartridges
 - 7-33. Fuzes
 - 7-34. Setting Fuzes
 - 7-35. Resetting Fuzes

CHAPTER 8 FIRE WITHOUT A FIRE DIRECTION CENTER

- Section I Fire Procedures
- 8-1. Advantages and Disadvantages
 - 8-2. Firing Data
 - 8-3. Observer Corrections
 - 8-4. Initial Fire Commands
 - 8-5. Fire Commands
 - 8-6. Fire Control
 - 8-7. Movement to Alternate and Supplementary Positions
 - 8-8. Squad Conduct of Fire
 - 8-9. Reference Line
 - 8-10. Fire Adjustment
 - 8-11. Squad Use of Illumination and Smoke
 - 8-12. Attack of Wide Targets
 - 8-13. Attack of Deep Targets

- Section II Direct-Lay Method
 - 8-14. Step 1: Initial Firing Data
 - 8-15. Step 2: Referring the Sight
 - 8-16. Step 3: Bracketing the Target
 - 8-17. Step 4: Fire for Effect
- Section III Direct-Alignment Method
 - 8-18. Mortar Dismounted
 - 8-19. Mortar Mounted
 - 8-20. Natural Object Method
- Section IV Adjustment of Range
 - 8-21. Range Spottings
 - 8-22. Miscellaneous Spottings
 - 8-23. Bracketing Method
 - 8-24. Creeping Method of Adjustment
 - 8-25. Normal Fire Commands
 - 8-26. Modified Fire Commands
 - 8-27. Fire Control
 - 8-28. Establishment of a Reference Line and Shifting From That Line
 - 8-29. Ladder Method of Adjustment

CHAPTER 9 GUNNER'S EXAMINATION

- Section I Preparatory Instruction
 - 9-1. Methods of Instruction
 - 9-2. Prior Training
 - 9-3. Preparatory Exercises
 - 9-4. Examining Board
 - 9-5. Location and Date
 - 9-6. Eligible Personnel
 - 9-7. Qualification Scores
 - 9-8. General Rules
- Section II Gunner's Examination With Ground-Mounted Mortar
 - 9-9. Subjects and Credits
 - 9-10. Equipment
 - 9-11. Organization
 - 9-12. Procedure
 - 9-13. Mounting of the Mortar

- 9-14. Small Deflection Change
- 9-15. Referring of the Sight and Realignment of Aiming Posts
- 9-16. Large Deflection and Elevation Changes
- 9-17. Reciprocal Laying
- Section III Gunner's Examination With the Track-Mounted Mortar
 - 9-18. Subjects and Credits
 - 9-19. Equipment
 - 9-20. Organization
 - 9-21. Procedure
 - 9-22. Placement of Mortar Into a Firing Position From Traveling Position
 - 9-23. Small Deflection Change
 - 9-24. Referring of the Sight and Realignment of Aiming Posts
 - 9-25. Large Deflection and Elevation Changes
 - 9-26. Reciprocal Laying
 - 9-27. Support Squad

APPENDIX A TRAINING DEVICES

APPENDIX B MORTAR TRAINING STRATEGY

GLOSSARY

REFERENCES

AUTHENTICATION

DISTRIBUTION RESTRICTION: Approved for public release, distribution is unlimited.

*This publication supersedes FM 55-1, 30 November 1984.

CHAPTER 1

INTRODUCTION

The mission of the mortar platoon is to provide close and immediate indirect fire support for the maneuver battalions and companies.

Section I. GENERAL DOCTRINE

Doctrine demands the timely and accurate delivery of indirect fire to meet the needs of supported units. All members of the indirect fire team must be trained to quickly execute an effective fire mission.

1-1. EFFECTIVE MORTAR FIRE

For mortar fire to be effective, it must be dense enough and must hit the target at the *right* time with the *right* projectile and fuze. Good observation is necessary for effective mortar fire. Limited observation results in a greater expenditure of ammunition and less effective fire. Some type of observation is desirable for every target to ensure that fire is placed on the target. Observation of close battle areas is usually visual. When targets are hidden by terrain features or when great distance or limited visibility is involved, observation can be by radar or sound. When observation is possible, corrections can be made to place mortar fire on the target by adjustment procedures; however, lack of observation must not preclude firing on targets that can be located by other means.

- a. Mortar fire must be delivered by the most accurate means that time and the tactical situation permit. When possible, survey data are used to accurately locate the mortar position and target. Under some conditions, only a rapid estimate of the location of weapons and targets may be possible. To achieve the most effective massed fires, a survey using accurate maps should be made of each mortar position, registration points, and targets.
- b. The immediate objective is to deliver a large volume of accurate and timely fire to inflict as many casualties as possible on the enemy. The number of casualties inflicted in a target area can usually be increased by surprise fire. If surprise massed fires cannot be achieved, the time required to bring effective fires on the target should be kept to a minimum. The greatest demoralizing effect on the enemy can be achieved by delivery of a maximum number of effective rounds from all the mortars in the shortest possible time.
- c. Mortar units must be prepared to accomplish multiple fire missions. They can provide an immediate, heavy volume of accurate fire for sustained periods. Mortars are suppressive indirect fire (high-angle-of-fire) weapons. They can be

employed to neutralize or destroy area or point targets, screen large areas with smoke, and to provide illumination or coordinated HE/illumination.

d. In the armor and mechanized infantry battalions, mortars are normally fired from mortar carriers; however, they maintain their capability to be ground-mounted. Firing from the carrier permits rapid displacement and quick reaction.

1-2. MORTAR POSITIONS

Mortars should be employed in defilade to protect them from enemy direct fire and observation, and to take the greatest advantage of their indirect fire role. Although the use of defilade precludes sighting the weapons directly at the target (direct lay), it is necessary for survivability. Because mortars are indirect fire weapons, special procedures ensure that the weapon and ammunition settings used will cause the projectile to burst on or above the target. A coordinated effort by the indirect fire team ensures the timely and accurate engagement of targets.

Section II. INDIRECT FIRE TEAM

Indirect fire procedure is a team effort (Figure 1-1). Since the mortar is normally fired from defilade (where the crew cannot see the target), the indirect fire team gathers and applies the required data. The team consists of an FO, an FDC, and the gun squad.

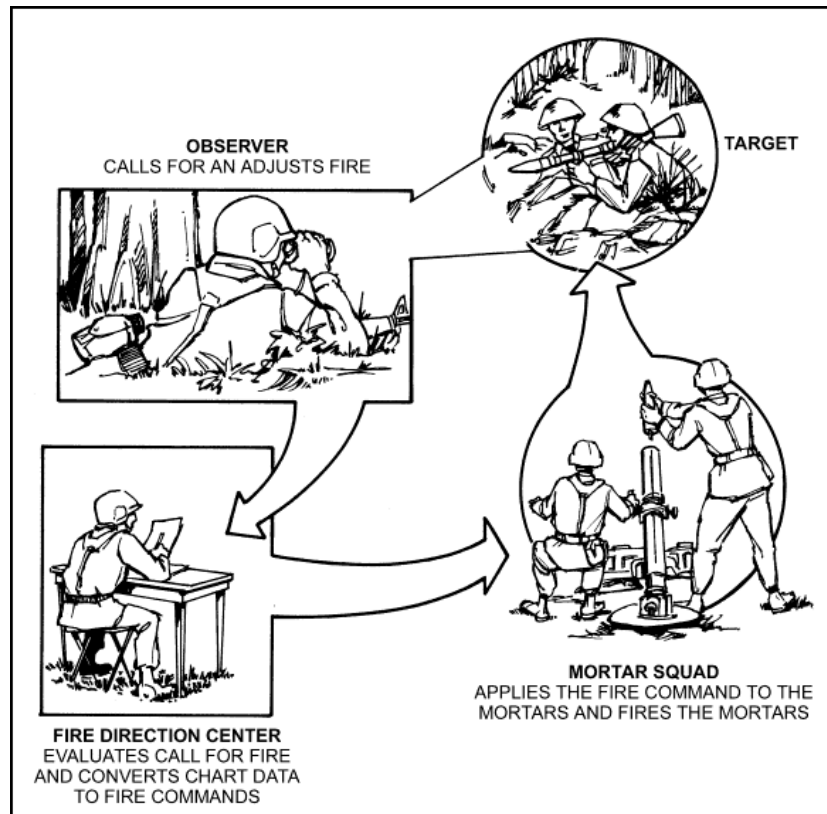

Figure 1-1. Indirect fire team.

1-3. APPLICATIONS

To successfully accomplish missions from a defilade position, certain steps must be followed in applying essential information and engaging targets.

- Locate targets and mortar positions.
- Determine chart data (direction, range, and vertical interval from mortars to targets).
- Convert chart data to firing data.
- Apply firing data to the mortar and ammunition.

1-4. TEAM MISSION

The team mission is to provide accurate and timely response to the unit it supports. Effective communication is vital to the successful coordination of the efforts of the indirect fire team.

- a. The forward observer (FO), as part of the fire support team (FIST), is normally provided by a direct support (DS) artillery battalion. One 4-man FO team supports each mechanized infantry company. The light infantry company is supported by a 10-man company-level FO team. The team is composed of a lieutenant, staff sergeant, radio-telephone operator, driver with a HMMWV at company headquarters, and six FOs (one 2-man team for each infantry platoon in the company). The FO's job is to find and report the location of targets, and to request and adjust fire.
- b. The fire direction center (FDC) has two computer personnel who control the mortar firing. They convert the data in a call for fire from the FO into firing data that can be applied to the mortars and ammunition.
- c. A mortar squad consists of three to five mortarmen, depending on the system. The squad lays the mortar and prepares the ammunition, using the data from the FDC fire command. When those data have been applied, the squad fires the mortar--it must also be able to fire without an FDC.

Section III. SAFETY PROCEDURES

Although safety is a command responsibility, each member of the mortar fire team must know safety procedures and enforce them. Misfire procedures discussed in this field manual are based on peacetime operations. (See ARTEP 7-90-Drill for combat operations.)

1-5. DUTIES OF THE SAFETY OFFICER AND SUPERVISORY PERSONNEL

Safety officers must help commanders meet the responsibility of enforcing safety procedures. The safety officer has two principal duties: first, to ensure that the section is properly laid so that when rounds are fired, they land in the impact area; second, to ensure that all safety precautions are observed at the firing point.

- a. **Duties Before Departing for Range.** The safety officer must read and understand the following:
 - AR 385-63.
 - Post range and terrain regulations.
 - The terrain request of the firing area to know safety limits and coordinates of firing positions.
 - Appropriate field and technical manuals pertaining to weapons and ammunition to be fired.

b. Duties of Supervisory Personnel. Supervisory personnel must know the immediate action to be taken for firing accidents. The following is a list of *minimum* actions that must be taken if an accident occurs.

- (1) Administer first aid to injured personnel, then call for medical assistance.
- (2) If the ammunition or equipment presents further danger, move all personnel and equipment out of the area.
- (3) Do not change any settings on or modify the position of the mortar until an investigation has been completed.
- (4) Record the ammunition lot number involved in the accident or malfunction and report it to the battalion ammunition officer. If a certain lot number is suspected, its use should be suspended by the platoon leader.

c. Mortar Range Safety Checklist. A mortar range safety checklist can be written for local use. The following is a suggested checklist, which can also include three columns on the right titled "Yes," "No," and "Remarks."

(1) *Items to check before firing.*

(a) Is a range log or journal maintained by the officer in charge?

(b) Is radio or telephone communication maintained with--

- Range control?
- Unit S3?
- Firing crews?
- Forward observers?
- Road or barrier guards?

(c) Are the required emergency personnel and equipment present on the range?

- Properly briefed and qualified medical personnel.
- A wheeled or tracked ambulance.
- Fire-fighting equipment.

(d) Are the following range controls and warning devices available, readily visible, and in use during the firing exercise?

- Barrier/road guards briefed and in position.
- Road barriers in position.
- Red range flag in position.

- Blinking red lights for night firing.
- Signs warning trespassers to beware of explosive hazards and not to remove duds or ammunition components from ranges.
- Noise hazard warning signs.

(e) Are current copies of the following documents available and complied with?

- AR 385-63.
- Technical and field manuals pertinent to the mortar in use.
- Appropriate firing tables.
- Installation range regulations.

(f) Are the following personal safety devices and equipment available and in use?

- Helmets.
- Protective earplugs.
- Protective earmuffs.

(g) Is the ammunition the correct caliber, type, and quantity required for the day's firing? Are the rounds, fuzes, and charges--

- Stored in a location to minimize possible ignition or detonation?
- Covered to protect them from moisture and direct sunlight?
- Stacked on dunnage to keep them clear of the ground?
- Strictly accounted for by lot number?
- Exposed only immediately before firing?
- Stored separately from ammunition and protected from ignition?

(h) Has the range safety officer verified the following?

- The mortar safety card applies to the unit and exercise.
- The firing position is correct and applies to the safety card, and the base mortar is within 100 meters of the surveyed firing point.
- Boresighting and aiming circle declination are correct.
- The plotting board or MBC is correct.
- The FO has been briefed on the firing exercise and knows the limits of the safety fan.
- The lay of each mortar is correct.
- The safety stakes (if used) are placed along the right and left limits.

- Each safety NCO and gunner has been informed in writing of the following:
 - Right and left limits (deflection).
 - Maximum elevation and charge.
 - Minimum elevation and charge.
 - Minimum time setting for fuzes.
- All personnel at the firing position have been briefed on safety misfire procedures.
- If the safety card specified overhead fire, firing is IAW AR 385-63.
- The mortars are safe to fire by checking-
 - Mask and overhead clearance.
 - Weapons and ammunition.
 - Properly seated sights on weapons.
 - Carefully positioned lights on the sights and aiming stakes for night firing.
- The OIC is informed that the range is cleared to fire and that range control has placed it in a "wet" status.

(2) Items to check during firing.

- (a) Are the unit personnel adhering to the safety regulations?
- (b) Is each charge, elevation, and deflection setting checked before firing?
- (c) Does the safety NCO declare the mortar safe to fire before the squad leader announces, "Hang it, fire"?
- (d) Do all gun settings remain at last data announced until a subsequent fire command is issued by the FDC?
- (e) Are ammunition lots kept separate to avoid the firing of mixed lots?

(3) Items to check after firing.

- (a) Have the gunners and safety NCO verified that no loose propellants are mixed with the empty containers?
- (b) Has the safety NCO disposed of the unused propellants?
- (c) Has the unused ammunition been inventoried and repacked properly?

(d) Have the proper entries been made in the equipment logbook (DA Form 2408-4).

(e) Has the OIC or safety officer notified range control of range status and other required information?

(f) Has a thorough range police been conducted?

d. **Safety Card.** The safety officer should receive a copy of the safety card from the OIC before allowing fire to begin. He constructs a safety diagram based on the information on the safety card. A safety card should be prepared and approved for each firing position and type of ammunition used. The form of the card depends upon local regulations (training list, overlay, range bulletin). Even without a prescribed format, it should contain the following:

- Unit firing or problem number.
- Type of weapon and fire.
- Authorized projectile, fuze, and charge zone.
- Grid of the platoon center.
- Azimuth of left and right limits.
- Minimum and maximum ranges and elevations.
- Any special instructions to allow for varying limits on special ammunition or situations.

e. **Safety Diagram.** The safety officer, on receipt of the safety card, constructs a safety diagram. The safety diagram is a graphic portrayal of the data on the safety card, which need not be drawn to scale but must accurately list the sight settings that delineate the impact area. The diagram serves as a convenient means of checking the commands announced to the gun crews against those commands that represent the safety limits.

(1) The diagram shows the right and left limits, expressed in deflections corresponding to those limits; the maximum and minimum elevations; and the minimum fuze settings (when applicable) for each charge to be fired. The diagram also shows the minimum and maximum range lines, the left and right azimuth limits, the deflections corresponding to the azimuth limits, and the direction on which the guns are laid. The safety diagram must show only necessary information.

(2) To accurately complete a safety diagram, the safety officer must use the information supplied by range control or, in the example in Figure 1-2, the safety card.

- | |
|--|
| <ol style="list-style-type: none">1. Enter the known data, supplied from the safety card, on the safety diagram.2. Determine the azimuth center sector. |
|--|

3. Determine mounting azimuth.
4. Determine mils left and right deviations of mounting azimuth.
5. Determine referred deflection.
6. Determine deflections to left and right limits.
7. Determine minimum and maximum charges and elevations.
8. If illumination is to be used, determine from the appropriate firing tables the minimum and maximum charges and ranges to burst and impact for the canister. The minimum range is used to determine the minimum charge and range to burst. The maximum range is used to determine the maximum charge and range to impact.

EXAMPLE

1. Place all data supplied by the safety card on the safety diagram at this time.
2. Add the right and left limits and divide by 2 to compute the azimuth center sector.

RIGHT LIMIT	0920
LEFT LIMIT	+ <u>0500</u>
TOTAL	= 1420

TOTAL = 1420 divided by 2 = 0710

3. The answer 0710 is the azimuth center sector to use.
4. Determine mounting azimuth. For all mortars (M16 plotting board), round off to nearest 50 mils; for example, 0710 = 0700.
5. Determine referred deflection. It can be any number, but 2800 is normally used.
6. Determine referred deflection for left and right limits.
 - a. Determine the number of mils from the mounting azimuth to the left limit.

MOUNTING AZIMUTH	0700
LEFT LIMIT	- <u>0500</u>
MILS TO LEFT LIMIT	= 0200

- b. Using the LARS rule for referred deflection, calculate the left limit deflection.

CENTER OF SECTOR	
REFERRED DEFLECTION	2800
MILS TO LEFT LIMIT	+ <u>0200</u>
LEFT LIMIT DEFLECTION	= 3000

- a. Determine the number of mils from the mounting azimuth to the right

limit.

RIGHT LIMIT 0920
MOUNTING AZIMUTH - 0700
MILS TO RIGHT LIMIT = 0220

- d. Using the LARS rule for referred deflection, calculate the right limit deflection.

CENTER OF SECTOR
REFERRED DEFLECTION 2800
MILS TO RIGHT LIMIT - 0220
RIGHT LIMIT DEFLECTION = 2580

7. Determine minimum and maximum charges and elevations by using the firing tables for the mortar being fired.

Note: When determining deflections for 4.2-inch mortars, add the minimum drift for the minimum range to the left limit deflection and maximum drift for the maximum range to the right limit deflection. This is the responsibility of the section sergeant.

Figure 1-2. Example of how to complete a safety diagram (continued).

1-6. AMMUNITION CARE AND HANDLING

A complete round of mortar ammunition contains all the components needed to get the round out of the tube and to burst it at the desired place and time. The key to proper ammunition functioning is protection. Rounds prepared but not fired should be placed back in their containers, fin end first. Safety is always a matter of concern for all section personnel, and it requires special attention where ammunition is concerned. Supervision is critical, because improper care and handling can cause serious accidents as well as inaccurate fire. Following are some of the principles of proper ammunition handling.

- Never tumble, drag, throw, or drop individual cartridges or boxes of cartridges.
- Do not allow smoking, open flames, or other fire hazards around ammunition storage areas.
- Inspect each cartridge before it is loaded for firing. Dirty ammunition can damage the weapon or affect the accuracy of the round.
- Keep the ammunition dry and cool.
- Never make unauthorized alterations or mix components of one lot with another.

Note: For care and handling of specific mortar rounds, see corresponding chapter in this manual.

a. **Projectiles/Cartridges.** Each projectile must be inspected to ensure that there is no leakage of the contents, and that the projectile is correctly assembled. The HE 4.2-inch mortar projectiles are issued without a fuze. Each is issued with a removable supplementary charge so that it can be used with an impact, mechanical, or VT (proximity) fuze.

b. **Burning of Unused Propelling Charges.** Mortar increments and propelling charges are highly flammable, and they must be handled with extreme care to preclude exposure to heat, flame, or any spark-producing source. This includes exposure to the hot residue from burning increments or propelling charges that float downward after a cartridge leaves the barrel. Like other types of ammunition, increments and propelling charges must be kept cool and dry. Storing these items inside the ammunition boxes until needed is an effective way to prevent premature combustion.

(1) Unused charges must not be saved but should be removed to a storage area until they can be burned or otherwise disposed of.

(2) Burning increments create a large flash and a lot of smoke. In a tactical environment, the platoon leader must ensure that burning increments do not compromise camouflage and concealment. The burning of increments in a dummy position, if established, can aid in the deception effort. The safety officer, in a range environment, supervises the disposal of unused propellant increments.

c. **Fuzes.** Never fire a round with a fuze that is not authorized for that round. Specific fuzes available for each weapon system are discussed in this manual.

(1) Fuzes are sensitive to shock and must be handled with care. Before fuzing a round, inspect the threads of the fuze and fuze well for cleanliness and crossed threads. The fuze should be screwed into the fuze well slowly until resistance is met and then firmly seated with a sharp twist of the M25 or M18 fuze wrench, as appropriate.

WARNING

Premature detonation may occur if a fuze is not properly seated.

(2) To prevent accidental functioning of the point-detonating elements of fuzes of the M524 series, the fuzes must not be dropped, rolled, or struck

under any circumstances. Any mechanical-time fuze that is set and modified must be reset to SAFE, and the safety wires (if applicable) must be replaced before the fuze is repacked in the original carton.

(3) All primers must be inspected before use for signs of corrosion. If a seal has been broken, it is likely that the primer has been affected by moisture and should be turned in.

d. **Segregation of Ammunition Lots.** Different lots of propellant burn at different rates and give slightly different effects in the target area. Therefore, the registration corrections derived from one lot do not always apply to another. Ammunition **MUST** be segregated by lot and weight zone (square weight [4.2-inch mortar only]). In the field storage area, on vehicles or in a dump, ammunition lots should be roped off with communications wire or twine and conspicuously marked with a cardboard sign or other marker.

1-7. FIELD STORAGE OF AMMUNITION

Most ammunition components can be stored at temperatures as low as -80 degrees F for not longer than three days and as high as 160 degrees F for not longer than four hours.

a. The greatest hazards to ammunition in the storage area are weather, enemy fire, NBC contamination, improper handling, and accidental fires. Regardless of the method of storage, those hazards must be considered. Some general considerations that apply to storage are as follows:

(1) Stack ammunition by type, lot number, and weight zone (Figure 1-3).

Note: WP ammunition must be stacked fuze-end up.

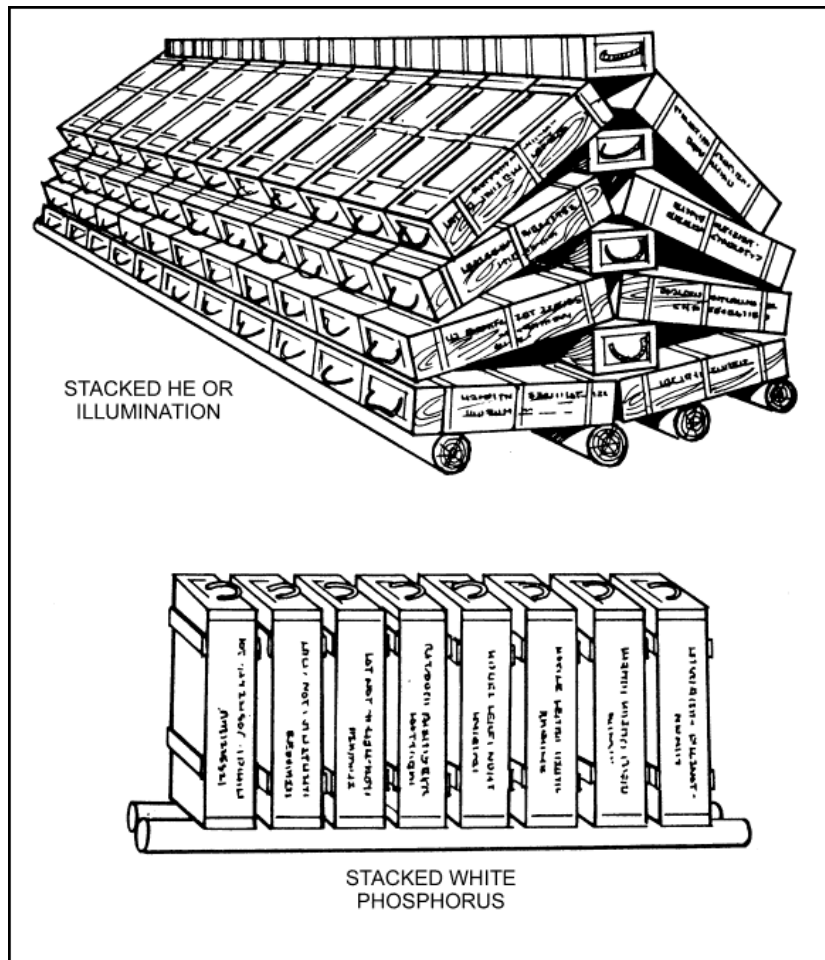

Figure 1-3. Stacked ammunition.

- (2) If ammunition is being stored on the ground, use good strong dunnage at least 6 inches under each stack.
- (3) Keep the ammunition dry and out of direct sunlight by storing it in a vehicle or covering it with a tarpaulin. Be sure adequate ventilation is provided around ammunition and between covering material and ammunition.

(4) Protect ammunition as much as possible from enemy indirect fires. If sandbags are used for protection, keep the walls at least 6 inches from the stacks and the roof at least 18 inches from the stacks to ensure proper ventilation.

b. An increase in malfunctions can occur with some proximity fuzes if fired when the temperature is below 0 degrees F or above 120 degrees F. Powder temperature affects the muzzle velocity of a projectile and is of frequent concern to the FDC.

CHAPTER 2

SIGHTING AND FIRE CONTROL EQUIPMENT

Proper employment of sighting and fire control equipment ensures effective fire against the enemy. This chapter describes this equipment and its applications.

Section I. COMPASS, M2

The compass (Figures 2-1 through 2-3) is used to measure azimuths or angles of site. It measures magnetic azimuths or grid azimuths, when the instrument has been declinated for the locality.

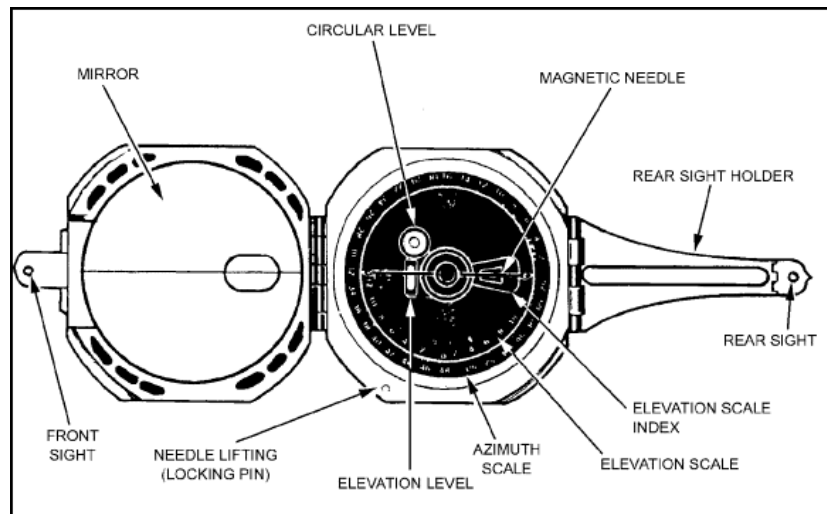

Figure 2-1. Compass, M2, (top view).

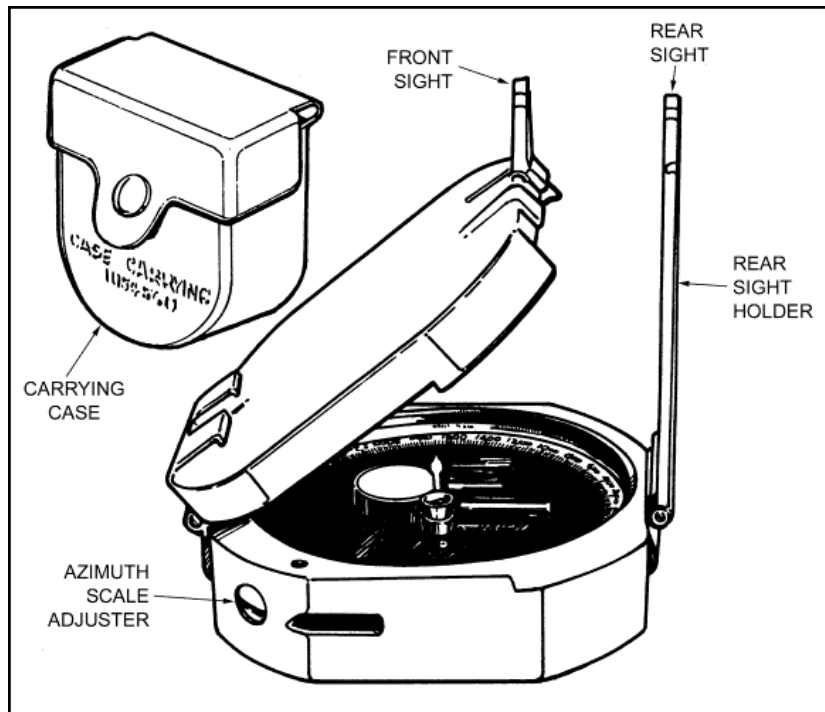

Figure 2-2. Compass, M2 (side view).

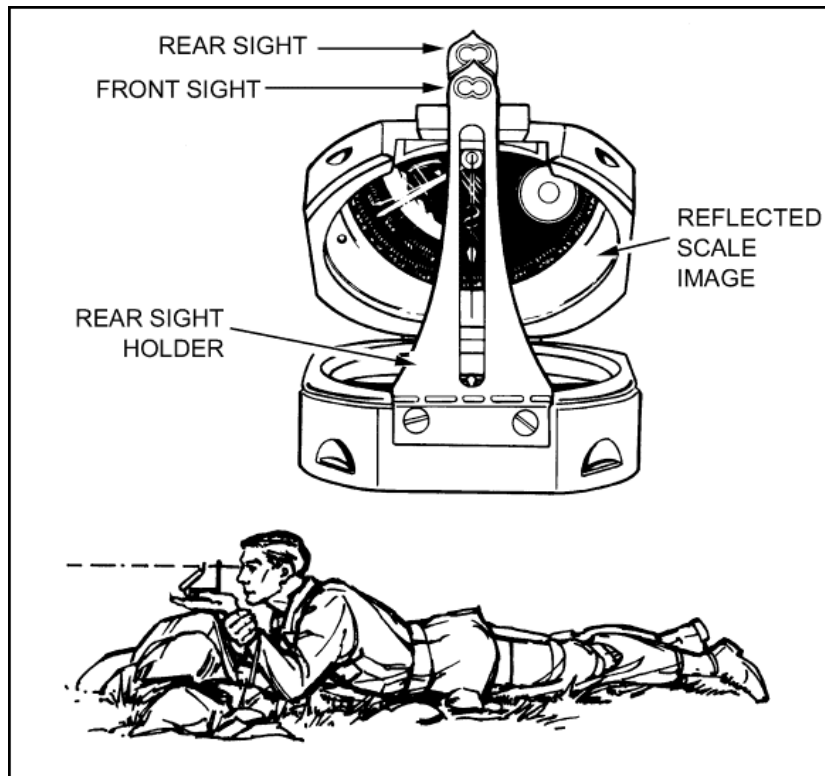

Figure 2-3. Compass, M2 (user's view).

Note: For detailed information, see TM 9-1290-333-15.

2-1. CHARACTERISTICS

The main characteristics of the M2 compass are:

Angle-of-site scale	1200-0-1200 mils
Azimuth Scale	0 to 6400 mils
Dimensions Closed	2 3/4 inches by 1 1/8 inches
Weight	8 ounces

2-2. DESCRIPTION

The principal parts of the compass are described herein.

a. **Compass Body Assembly.** This assembly consists of a circular glass window that covers the instrument, and keeps dust and moisture from its interior, protecting the compass needle and angle-of-site mechanism. A hinge assembly holds the compass cover in the position in which it is placed. A hole in the cover coincides with a small oval window in the mirror on the inside of the cover. A sighting line is etched across the face of the mirror.

b. **Angle-of-Site Mechanism.** The angle-of-site mechanism is attached to the bottom of the compass body. It consists of an actuating (leveling) lever located on the back of the compass, a leveling assembly with a tubular elevation level, and a circular level. The instrument is leveled with the circular level to read azimuths and with the elevation level to read angle of site. The elevation (angle-of-site) scale and the four points of the compass, represented by three letters and a star, are engraved on the inside bottom of the compass body. The elevation scale is graduated in two directions; in each direction it is graduated from 0 to 1200 mils in 20-mil increments and numbered every 200 mils.

c. **Magnetic Needle and Lifting Mechanism.** The magnetic needle assembly consists of a magnetized needle and a jewel housing that serves as a pivot. The north-seeking end of the needle is white. (The newer compasses have the north and south ends of the needle marked "N" and "S" in raised, white lettering.) On some compasses a thin piece of copper wire is wrapped around the needle for counterbalance. A lifting pin projects above the top rim of the compass body. The lower end of the pin engages the needle-lifting lever. When the cover is closed, the magnetic needle is automatically lifted from its pivot and held firmly against the window of the compass.

d. **Azimuth Scale and Adjuster.** The azimuth scale is a circular dial geared to the azimuth scale adjuster. This permits rotation of the azimuth scale about 900 mils in either direction. The azimuth index provides a means of orienting the azimuth scale at 0 or the declination constant of the locality. The azimuth scale is graduated from 0 to 6400 in 20-mil increments and numbered at 200-mil intervals.

e. **Front and Rear Sight.** The front sight is hinged to the compass cover. It can be folded across the compass body, and the cover is closed. The rear sight is made in two parts--a rear sight and holder. When the compass is not being used, the rear sight and holder are folded across the compass body and the cover is closed.

2-3. USE

The compass should be held as steadily as possible to obtain accurate readings. The use of a sitting or prone position, a rest for the hand or elbows, or a solid nonmetallic support

helps eliminate unintentional movement of the instrument. When being used to measure azimuths, the compass must not be near metallic objects.

a. To measure a magnetic azimuth--

- (1) Zero the azimuth scale by turning the scale adjuster.
- (2) Place the cover at an angle of about 45 degrees to the face of the compass so that the scale reflection is viewed in the mirror.
- (3) Adjust the front and rear sights to the desired position. Sight the compass by any of these methods:
 - (a) Fold the rear sight holder out parallel with the rear sight of the compass face perpendicular to its holder. Sight through the window in the cover. If the object sighted is at a lower elevation than the compass, raise the rear sight holder as needed. The compass is correctly sighted when it is level and the black centerline of the window, rear sight, and object are aligned.
 - (b) Raise the front and rear sights perpendicular to the face of the compass (Figure 2-2 and Figure 2-3). Sight over the tips of the rear and front sights. The compass is correctly sighted when it is level and the tips of the sights and object are aligned.
- (4) Hold the compass in both hands, at eye level, with the arms braced against the body and the rear sight near the eyes. For precise measurements, rest the compass on a nonmetallic stake or object.
- (5) Level the instrument by viewing the circular level in the mirror and moving the compass until the bubble is centered. Sight on the object, look in the mirror, and read the azimuth indicated by the black (south) end of the magnetic needle.

b. To measure a grid azimuth--

- (1) Index the known declination constant on the azimuth scale by turning the azimuth scale adjuster. Be sure to loosen the locking screw on the bottom of the compass. (The new lightweight [plastic] M2 compass has no locking screw.)
- (2) Measure the azimuth as described above. The azimuth measured is a grid azimuth.

c. To measure an angle of site or vertical angle from the horizontal--

(1) Hold the compass with the left side down (cover to the left) and fold the rear sight holder out parallel to the face of the compass, with the rear sight perpendicular to the holder. Position the cover so that, when looking through the rear sight and the aperture in the cover, the elevation vial is reflected in the mirror.

(2) Sight on the point to be measured.

(3) Center the bubble in the elevation level vial (reflected in the mirror) with the level lever.

(4) Read the angle on the elevation scale opposite the index mark. The section of the scale graduated counterclockwise from 0 to 1200 mils measures plus angles of site. The section of the scale graduated clockwise from 0 to 1200 mils measures minus angles of site.

Section II. AIMING CIRCLES, M2 AND M2A2

The aiming circle is used to obtain angular values. It is a low-power telescope that is mounted on a composite body and contains a magnetic compass, adjusting mechanisms, and leveling screws for establishing a horizontal plane. The instrument is supported by a baseplate for mounting on a tripod. Angular measurements in azimuth are indicated on graduated scales and associated micrometers.

2-4. CHARACTERISTICS

The main characteristics of the aiming circles are described herein.

	M2	M2A2
Weight (w/o equipment)	9 pounds	9 pounds
Weight (w/equipment less batteries)	21 pounds	21 pounds
Azimuth rotation	6400 mils	6400 mils
Elevation (maximum)	800 mils	1100 mils
Depression (maximum)	400 mils	400 mils
Magnification	4 power	4 power
Field of view	10 degrees	10 degrees

2-5. DESCRIPTION

The M2 and M2A2 aiming circles consist of an elbow telescope mounted on orienting and elevating mechanisms, which are contained within a main housing. The main housing, in turn, is supported by adjusting screws through the baseplate.

2-6. USE

The M2 or M2A2 aiming circle (Figure 2-4) is used for the precise measurement of the azimuth and elevation angles of a ground or aerial target with the respect to a preselected baseline as required for the orientation of indirect fire weapons. It can also be used for general topographical surveying.

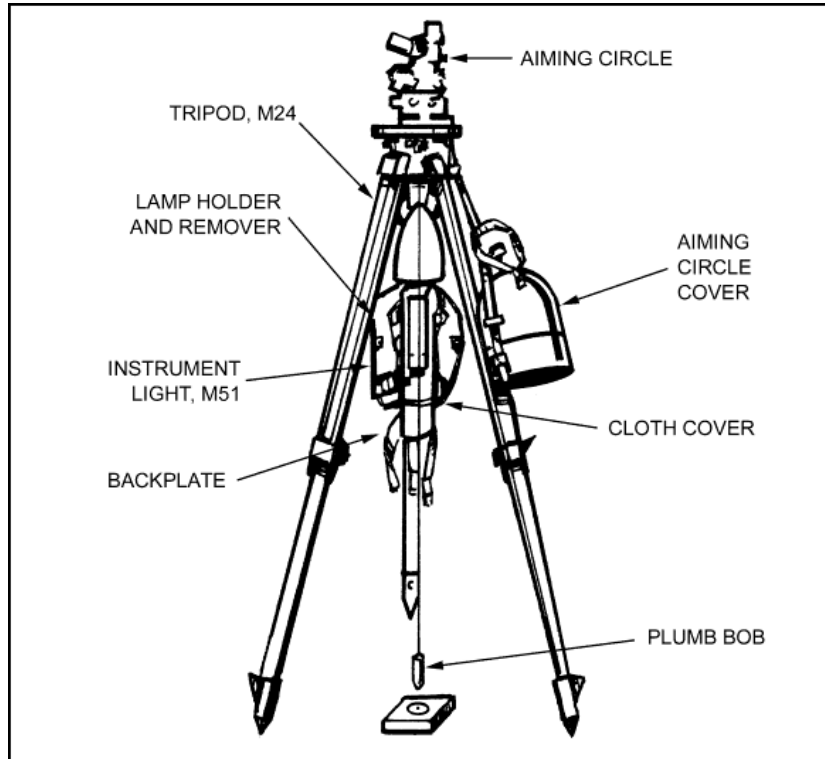

Figure 2-4. Aiming circles, M2 and M2A2, and accessory equipment.

Note: For detailed information, see TM 9-1290-262-15.

- a. The orienting and elevating mechanisms permit unlimited azimuth orienting movement (360 degrees [6400 mils] and limited elevation and depression [M2, 1200 mils; M2A2, 1500 mils]). Azimuth orienting rotation is controlled by two orienting knobs (Figure 2-5). Azimuth measurement is controlled by the micrometer knob. Elevation and depression movement are controlled by the elevation micrometer knob. The azimuth micrometer worm can be disengaged to

provide rapid azimuth measurement of movement by exerting pressure on the azimuth micrometer knob against the pressure of an internal spring-loaded plunger. Releasing the pressure on the azimuth micrometer knob allows the mechanism to reengage. A similar throw-out mechanism permits the azimuth orienting worm to also be disengaged to provide rapid azimuth orienting movement.

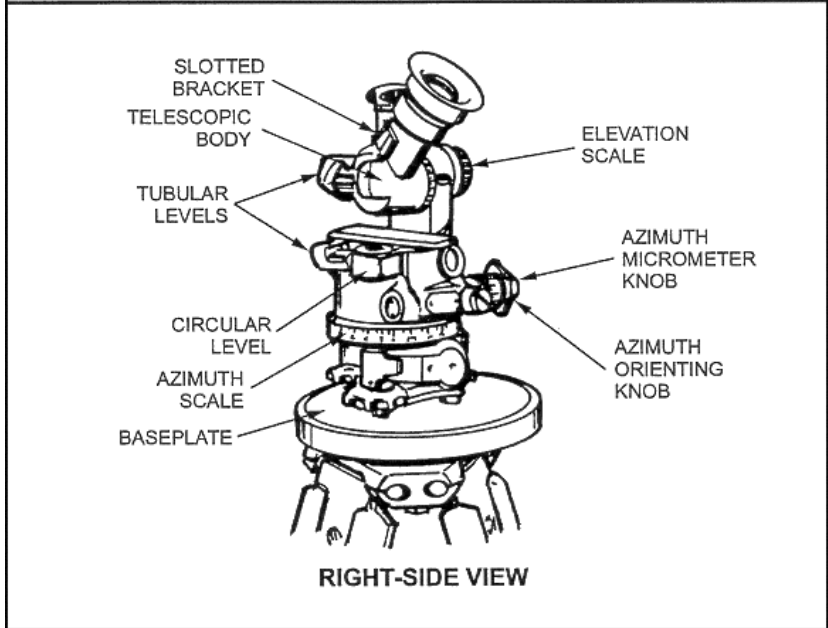
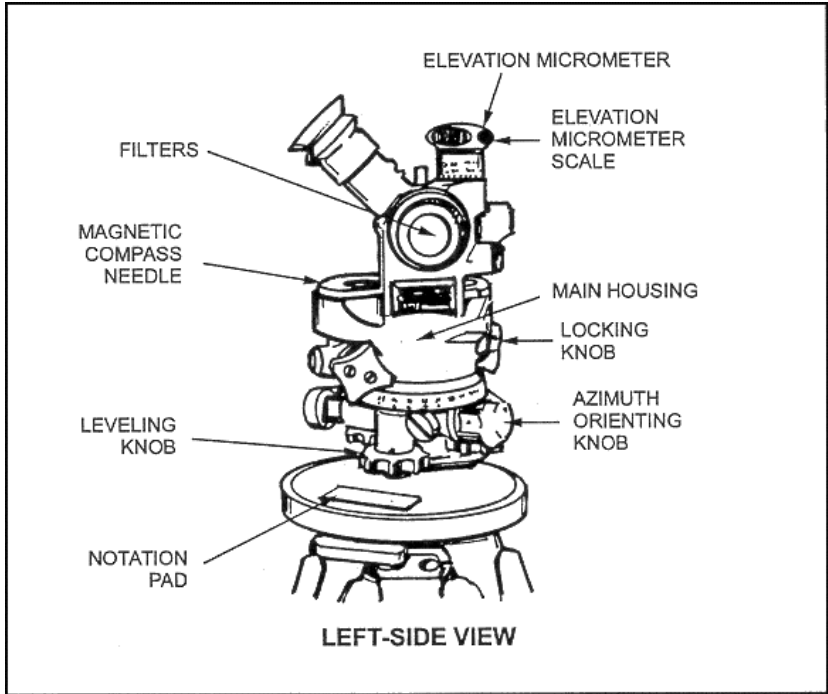

Figure 2-5. Aiming circle, M2

b. The telescope of the aiming circle is a four-power, fixed-focus, elbow-type instrument. The reticle of the telescope contains cross lines graduated to give azimuth and elevation angular readings from 0 to 85 mils in 5-mil increments. Thus, the FO can read small angular values directly from the reticle without referring to the azimuth and elevation micrometer scales. An externally stowed filter is provided for protection against the rays of the sun. A slotted bracket provides the means of securing the lamp bracket on one lead wire of the M51 instrument light so that illumination of the reticle during night operation can be accomplished. The reflector can be illuminated and used in conjunction with the sightunits on the mortars during night operations to backlight the vertical centerline of the aiming circle.

c. Three levels are contained within the telescope body and main housing of the aiming circle. One tubular level, held between two bosses on the telescope body, is used to establish a true horizontal line-of-sight. The two bosses supporting this level are machined to form an open sight for approximate alignment of the telescope and target, and for quick or emergency sighting. One circular level and one tubular level are held within bosses on the main housing. The circular level is used for rough leveling of the aiming circle, and the tubular level is used for fine leveling adjustments. The three leveling screws on the baseplate are used to level the instrument and each is controlled by a leveling screw knob.

d. A magnetic compass needle is located in a recess in the top of the housing. A magnifier and rectangular reticle located at one end of the recess enable the FO to observe the end of the compass needle and to align the line of sight of the telescope with the needle. The compass needle can be locked in position by actuating the locking lever on the side of the housing.

e. Azimuth scales and elevation scales are employed to measure accurate azimuth or elevation angles. The scales provide coarse readings and the micrometer provides fine reading. The two readings added together give the angle. Graduation intervals and numeral scales are graduated into relatively large round number intervals for convenience in reading. The scale intervals are in graduations of 100 mils.

(1) The azimuth scale is graduated from 0 to 6400 mils (zero equals 6400). The upper series forms the main azimuth scale, colored black and numbered at 200-mil intervals. The lower series, colored red, is numbered from 0 to 3200 mils (the large zero in the main scale equals 3200). The red scale should only be used when verifying the lay of the aiming circle with another aiming circle.

(2) The azimuth micrometer scale is graduated at 1-mil intervals and numbered from 0 to 100 at ten 10-mil intervals.

(3) The elevation scale is graduated and numbered on both sides of 0. Minus (red) readings represent depression and plus (black) readings represent elevations at 100-mil intervals from minus 400 to 800 mils.

(4) The elevation micrometer scale is graduated at 1-mil intervals from 0 to 99 mils--large zero is designated 0 and 100. Red numerals represent depression and black numerals represent elevation.

f. A notation strip is provided on the baseplate. This strip is a raised and machined surface on which scale readings, settings, or other data can be recorded for reference.

2-7. ACCESSORY EQUIPMENT

The accessory equipment for the M2 aiming circle includes the aiming circle cover, M24 tripod, and the accessory kit which includes the M51 instrument light, backplate, cloth cover, plumb bob, and a lamp holder and remover. This equipment is mounted on the M24 tripod when the instrument is set up for use.

a. The *aiming circle cover* is a metal cover that protects and houses the aiming circle when not in use. It attaches to the baseplate of the aiming circle and can be carried by means of its strap. When the aiming circle is in use, the cover is placed on the tripod head cover.

b. The *M24 tripod* comprises three telescoping wooden legs hinged to a metal head, which contains a captive screw for attaching the aiming circle. When not in use, the tripod cover should be fitted on the head to protect the head and captive screw from damage, and the legs are held retracted by a strap. Attachments are provided so that the aiming circle cover and cloth cover with attached accessory equipment can be mounted on its legs when the aiming circle is set up for use. A hook is also provided from which the plumb bob can be suspended by means of its attaching thread when in use.

c. The *M51 instrument light* is a lighting device for use with the M2 aiming circle during night operations and for certain test and adjustment procedures. The light is flashlight battery-powered and contains two attaching lead wires. A lamp bracket attached to one lead wire can be inserted into the slotted bracket of the aiming circle telescope for illumination of the telescope reticle. A hand light, attached to the other lead wire, can be used for general-purpose illumination (scales, level vials, reflector, compass needle, and so forth). Rotation of the rheostat knob turns the two lamps on and off and increases or decreases the intensity of illumination.

d. The *backplate* provides the necessary clips and attachments for securing and protecting the instrument light and lamp bracket, hand light, and lead wires of the light. The plate with the attached instrument light is stored within the cloth cover.

e. The *cloth cover* is used to store the backplate and attached M51 instrument light. It is also used to store the plumb bob and a lamp holder and remover. When the aiming circle is set up for use, the cloth cover with attached equipment is mounted on one of the legs of the M24 tripod. When not in use, attached snap fasteners keep the cover in a closed position.

f. The *plumb bob* is used to aid in orienting the aiming circle over a certain grid point. It composes a pointed weight attached to a nylon thread that can be suspended from the hook under the tripod head when in use. The effective length of the thread can be adjusted by means of the slide. When not in use, the plumb bob is stored within the cloth cover.

g. A *lamp holder* and *remover* are used to hold spare incandescent lamps for the M51 instrument light. They also facilitate the removal and replacement of unserviceable lamps in the light.

2-8. SETUP AND LEVELING OF AIMING CIRCLE

The aiming circle must always be level during operation.

a. Unstrap the tripod legs, loosen the leg clamp thumbscrews, extend the legs so that the tripod is about chest high, and tighten the leg clamp thumbscrews. Spread the legs about 18 inches apart, adjust the legs so the tripod head is about level, and plant the feet firmly in the ground.

b. Remove the tripod head cover. Open the baseplate cover of the aiming circle head. Keeping the baseplate cover pointed toward you, thread the tripod guide screw assembly into the aiming circle until it is firmly seated. The base of the aiming circle should not protrude over the machine surface of the tripod head. Pull out and down on the strap latch assembly. Remove the cover and hang it on the tripod head cover.

c. If the instrument is to be set up over an orienting point, attach the plumb bob to the hook. Adjust the tripod legs and aiming circle head until it is over the point.

d. Loosen the leveling screws to expose sufficient threads ($3/8$ to $1/2$ inch) on the three screws to permit the instrument to be leveled. Number the leveling screws clockwise, 1, 2, and 3 (Figure 2-6). Now place the tubular level vial over the notation pad. Grasp leveling screw number 1 between the thumb and forefinger of the right hand, and grasp leveling screw number 2 between the thumb and forefinger of the left hand. Turn the screws so that the thumbs move toward or away from each other. Using these two leveling screws, center the bubble. The bubble moves in the same direction as the left thumb.

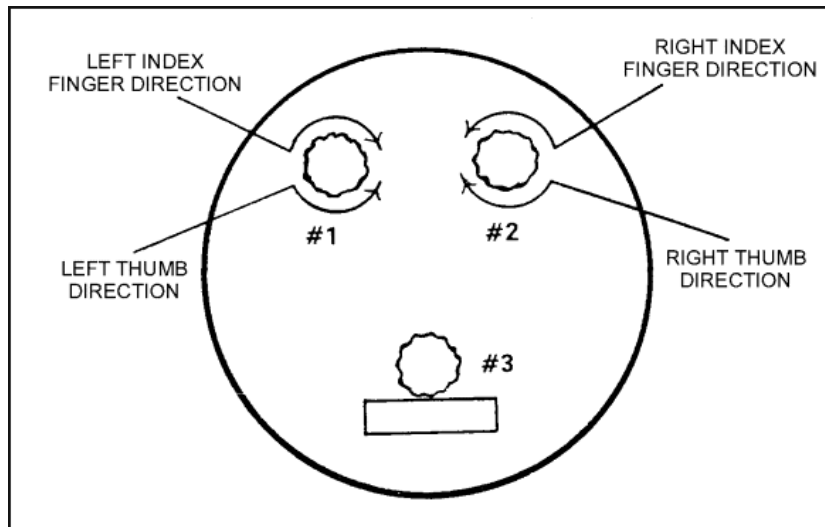

Figure 2-6. Leveling screws.

e. Rotate the aiming circle head until the magnifier is over the notation pad. Level the tubular level by turning only level screw number 3. The bubble should now remain level in any direction that the aiming circle is rotated. A variation of one graduation from the center of the vial is acceptable. If the bubble does not remain level, repeat this procedure.

Note: If the spring plate is bent, the aiming circle cannot be leveled and must be turned in to the DS maintenance unit.

f. The aiming circle should be set up at the distance indicated from the following objects:

OBJECT	DISTANCE (METERS)
High-tension power lines	150
Electronic equipment	150
Railroad tracks	75
Tanks and trucks	75
Vehicles	50
Barbed wire	30
Mortars or telegraph wire	25
Helmets, and so forth	10

2-9. DECLINATION CONSTANT

Since the magnetic needle of an aiming circle does not point to the grid north determined from a map, it is necessary to correct for this difference by using the declination constant. The declination constant of an instrument is the clockwise angle between grid north and magnetic north; that is, the grid azimuth of magnetic north. This constant differs slightly for different instruments and must be recorded on each instrument. The constant also varies for the same instrument in different localities. To determine the declination constant, proceed as follows:

a. **Declination Station.** Declination stations are established by corps artillery, division artillery, and artillery battalion survey teams to determine the declination constants of instruments and to correct for local attractions, annual variations, and instrument errors. When a unit moves from one locality to another, a station should be established where all instruments are declinated. If the declination constants for all instruments of a unit are determined at the same station, grid azimuths measured with each instrument will agree with the map grid, and all instruments will agree with each other. The point chosen for the declination station must have a view of at least two distant, well-defined points with a known grid azimuth. Two additional points are desirable, one in each quadrant, as a check.

b. **Procedure for Declinating Aiming Circle at a Declination Station.** Where a declination station is available, the procedure for declinating the aiming circle is as follows:

- STEP 1. Set up and fine-level the aiming circle directly over the declination station marker using the plumb bob.
- STEP 2. Place the grid azimuth of the first azimuth marker on the scales using the recording motion. Place the vertical cross line of the telescope on the azimuth marker using the nonrecording (orienting) motion. The aiming circle is now oriented on grid north.
- STEP 3. With the recording motion, rotate the instrument to zero. Release the magnetic needle and look through the magnifier. Center the north-seeking needle using the recording motion, then relock the magnetic needle.
- STEP 4. Notice the new azimuth on the scale, which is the declination constant--record it.
- STEP 5. Recheck the aiming circle level and repeat steps 2 through 4 using the remaining azimuth markers until three readings have been taken. If there is only one marker, repeat the entire procedure twice using the same marker.

STEP 6. Find the average declination constant using these three readings.

EXAMPLE 1

1st point reading = 6399 mils
2d point reading = 6398 mils
3d point reading = 6398 mils

Total = 19195 mils

$19195 \div 3 = 6398.3$ (rounded off to the nearest whole number) =
6398 mils (average declination constant)

EXAMPLE 2

1st point reading = 0030 mils
2d point reading = 0031 mils
3d point reading = 0029 mils

Total = 0090 mils

$0090 \div 3 = 0030$ mils (average declination constant)

STEP 7. Record the average declination constant in pencil on the notation (strip) pad of the aiming circle as its declination constant. All readings should be within 2 mils of each other; if not, repeat steps 2 through 4. Ensure the aiming circle is directly over the station marker to obtain the 2-mil tolerance. If the desired 2-mil accuracy is not gained after two tries, the aiming circle is defective and should be turned in for repair.

c. **Use of the Grid-Magnetic Angle.** If an aiming circle is used in a new area without a declination station, a declination constant can be determined by using the grid-magnetic (GM) angle from a map. When the GM angle (converted to mils) is westerly, it is subtracted from 6400 mils. The remainder is the declination constant. When the GM angle is easterly, the angle (in mils) is the declination constant.

d. **Redeclination of an Aiming Circle.** An aiming circle is redeclinated when moved over 25 miles (40 kilometers) from the last declination station. It is also redeclinated upon initial issue, when returned from repair (if 30 days since last declinated), or if severely jolted.

e. **Procedure for Declinating an Aiming Circle When a Declination Station is Not Available.** This procedure is the least desirable and should be used only

when no other means are available. It does not compensate for the error that could be inherent in the aiming circle.

(1) Determine the GM angle from the map of the area in which the aiming circle is to be used. This GM angle is used as indicated below.

(2) In 1, Figure 2-7, the difference between grid north and magnetic north is 200 mils (westerly). This total is then subtracted from 6400 mils. The declination constant that can be used is 6200 mils.

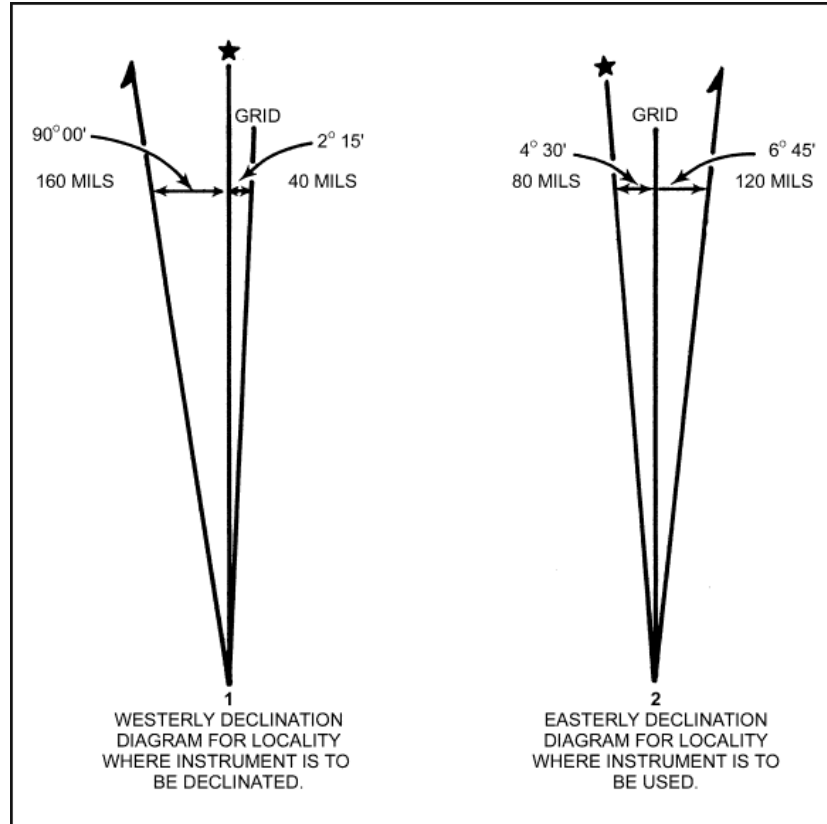

Figure 2-7. Marginal data from a map.

(3) In 2, Figure 2-7, the difference between grid north and magnetic north in a clockwise direction is 120 mils. This can be used as the declination constant.

f. When to Declinate the Aiming Circle. Certain rules prescribe how often and under what circumstances the aiming circle should be declinated to determine and keep the declination constant current. These rules are as follows:

(1) The aiming circle should be declinated when it is moved 25 miles or more from the area in which it was last declinated. A move of a few miles can change the relationship of grid north and magnetic north as measured by the instrument. In some locations, a move of less than 25 miles could require declination of the aiming circle.

(2) The aiming circle must be declinated after an electrical storm or after receiving a severe shock, such as a drop from the bed of a truck to the ground. The magnetic needle is a delicately balanced mechanism, and any shock can cause a significant change in the declination constant.

(3) The aiming circle should be declinated every 30 days to guard against changes that may have occurred due to unreported accidents to the instrument. If a radical change is observed, the instrument should be declinated again within a few days to determine if the observed change was due to a magnetic storm or is a real change in the characteristics of the instrument.

(4) The aiming circle should be declinated when it is initially received and when it is returned from support maintenance repair. Variations in the declination constant due to the time of day are not significant enough to warrant declinating again.

2-10. ORIENTING OF THE INSTRUMENT ON GRID NORTH TO MEASURE GRID AZIMUTH TO OBJECTS

The procedure to orient the aiming circle on grid north to measure grid azimuth to objects is as follows:

- a. Level the instrument.
- b. Set the azimuth micrometer and the azimuth scale on the declination constant of the instrument.
- c. Release the magnetic needle.
- d. With the orienting knob, align the south end of the needle accurately with the center etched line by using the magnetic needle magnifier.

- e. Lock the magnetic needle and close the orienting knob covers.
- f. Using the throw-out mechanism (azimuth knob), turn the telescope until the vertical line of the reticle is about on the object.
- g. By rotating the azimuth knob, bring the vertical line exactly on the object.
- h. Read the azimuth to the object on the azimuth and micrometer scales.

2-11. MEASUREMENT OF HORIZONTAL ANGLE BETWEEN TWO POINTS

To measure the horizontal angle between two points, at least two measurements should be made.

- a. Set the azimuth micrometer and the azimuth scale at zero.
- b. Rotate the instrument using the orienting knob throw-out mechanism until the vertical line of the telescope is about on the left edge of the left-hand object.
- c. Lay the vertical line exactly on the right edge of the left-hand object by rotating the orienting knob.
- d. Using the throw-out mechanism (azimuth knob), turn the telescope clockwise until the vertical line is about on the left edge of the right-hand object.
- e. Lay the vertical line exactly on the left edge of the right-hand object by turning the azimuth knob.
- f. Read the horizontal angle on the scales and record the value to the nearest 0.5 mil. This completes the first repetition.
- g. Rotate the aiming circle, using the lower motion, until the vertical cross line is again on the rear station.

Note: The value obtained from the first repetition is still on the scales.

- h. Rotate the aiming circle body, using the upper motion, until the vertical cross line is again on the forward station.
- i. Read and record the accumulated value of the two measurements of the angle to the nearest 0.5 mil. This completes the second repetition.
- j. Divide the second reading by 2 to obtain the mean angle to the nearest 0.1 mil. This mean angle must be within 0.5 mil of the first reading; if it is not, the measurement is void and the angle is measured again.

2-12. ORIENTING OF THE 0-3200 LINE ON A GIVEN GRID AZIMUTH

The procedure for orienting the 0-3200 line of the aiming circle on a given grid azimuth is illustrated below. In this example, the mounting azimuth is 5550 mils and the aiming circle is assumed to have a declination constant of 6380 mils.

- a. Set up and level the aiming circle.
- b. Subtract the announced mounting azimuth from the declination constant of the aiming circle (adding 6400 to the declination constant of the aiming circle if the mounting azimuth is larger). In this case, subtract the mounting azimuth 5550 from the declination constant 6380.

Solution:

Declination constant	6380 mils
Announced mounting azimuth	- <u>5550</u> mils
Remainder	830 mils

- c. Set the remainder on the azimuth and micrometer scales of the aiming circle. In this case, the remainder is 830 mils (recording motion).
- d. Release the compass needle. Look through the window in the cover housing and rotate the instrument until the needle floats freely using the orienting knob throw-out mechanism. For fine adjustments, use orienting knobs until the magnetic needle is exactly centered on the etched marks on the magnifier. Relock the compass needle to orient the 0-3200 line of the aiming circle on the mounting azimuth; in this case, grid azimuth of 5550 mils (Figure 2-8).

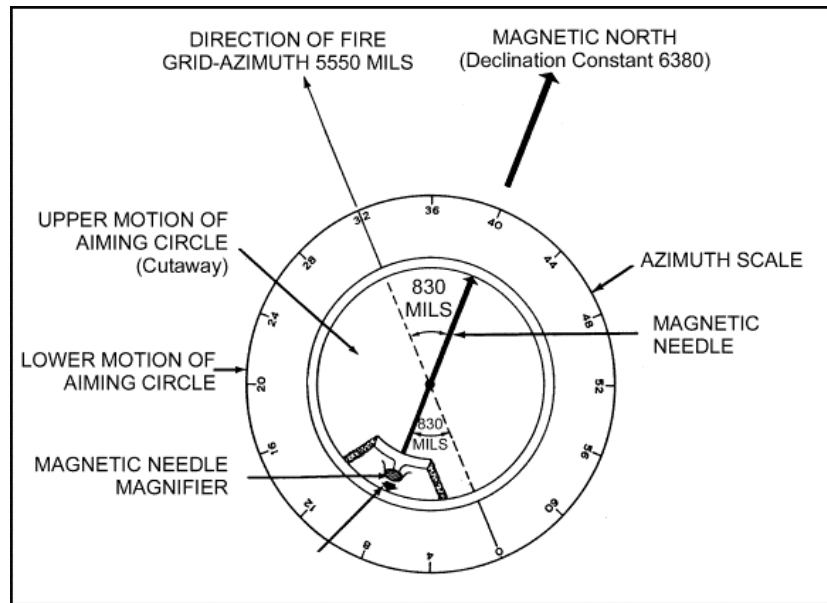

Figure 2-8. Aiming circle oriented in desired direction of fire.

- e. Once the aiming circle is oriented, do not disturb the lower motion of the aiming circle.

2-13. ORIENTING OF THE 0-3200 LINE ON A GIVEN MAGNETIC AZIMUTH

The procedure for orienting the 0-3200 line of the aiming circle on a given magnetic azimuth is as follows:

- a. Subtract the announced magnetic azimuth from 6400.
- b. Set the remainder on the azimuth and micrometer scales of the aiming circle.
- c. Release the compass needle and rotate the orienting knob until the magnetic needle is exactly centered in the magnetic needle magnifier. Lock the compass needle.
- d. The 0-3200 line of the aiming circle is now oriented on a given magnetic azimuth.

2-14. VERIFYING THE LAY OF THE PLATOON

After the platoon is laid, the platoon leader verifies the lay by using another M2 aiming circle, which is referred to as the safety circle.

- a. The platoon leader or designated safety officer sets up and orients an M2 aiming circle by using the method that was used with the lay circle (Figure 2-9). The aiming circle must be located where it can be seen by all mortars and should not be closer than 10 meters to the lay circle.

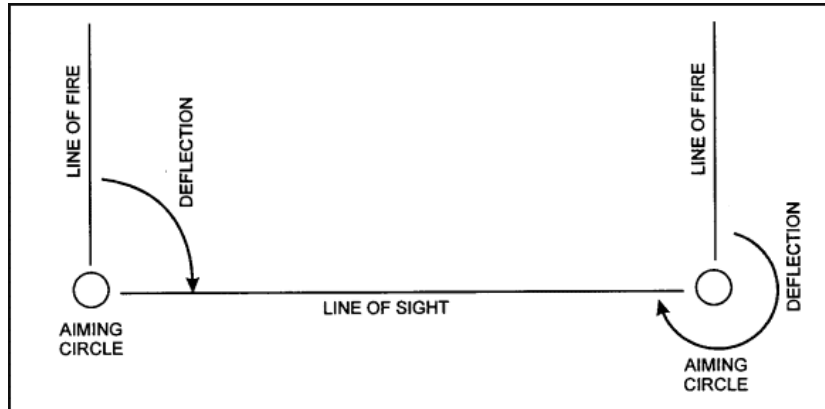

Figure 2-9. Method used to orient an M2 aiming circle.

- b. After picking up a line of sight on the lay circle, the safety circle operator commands, LAY CIRCLE REFER, AIMING POINT THIS INSTRUMENT. The lay circle operator sights his instrument onto the safety circle by use of the recording motion.
- c. When the aiming circle is used to orient another aiming circle for direction, the reading between the two circles will be 3200 mils apart, because both circles measure horizontal clockwise angles from the line of fire. To prevent confusion, remember that if you see red, read red. One half of the aiming circle azimuth scale has a second red scale that goes in the opposite direction of the black scale.
- d. There should be no more than 10 mils difference between the circles.
- e. If the lay circle and the safety circle deflection are within the 10-mil tolerance, the instrument operator on the safety circle places the deflection reading by the lay circle on the upper motion of the safety circle. With the lower motion, the instrument sights back on the lay circle. This serves to align the 0-3200 line of the safety circle parallel to the 0-3200 line of the lay circle.

f. The instrument operator on the safety circle commands, PLATOON, REFER AIMING POINT THIS INSTRUMENT. All gunners refer and announce the deflection to the safety circle. If the deflection referred by the mortar is within 10 mils, the operator on the safety circle announces that the mortar is safe. Once the mortars are safe, the operator announces, "The platoon is safe."

g. The platoon leader walks the gun line and visually checks the guns to ensure they are parallel. An M2 compass should also be used to ensure the guns are on the azimuth of fire.

2-15. ORIENTING BY ORIENTING ANGLE

Orienting by orienting angle eliminates magnetic errors that result from the use of the magnetic needle of the aiming circle.

a. An orienting angle is the horizontal clockwise angle from the mounting azimuth to the orienting line, the vertex being at the orienting station. It is a line of known direction established on the ground near the firing section which serves as a basis for laying for direction. This line is established by a survey team.

b. The instrument operator sets the aiming circle over the orienting station and levels it. He places the orienting angle on the azimuth scale. He then sights on the far end of the orienting line, using the lower motion. The magnetic needle is not used to orient the aiming circle. This eliminates any magnetic error that may exist in the instrument. The orienting knob cover is closed.

c. The 0-3200 line of the aiming circle is now oriented parallel to the mounting azimuth. Example azimuth of orienting line is 3200 mils. The azimuth on which the section leader wishes to lay the section is 1600 mils. The orienting angle is 1600 mils (Figure 2-10).

Azimuth of orienting line	3200 mils
Minus mounting azimuth	1600 mils
Orienting angle	- <u>1600 mils</u>

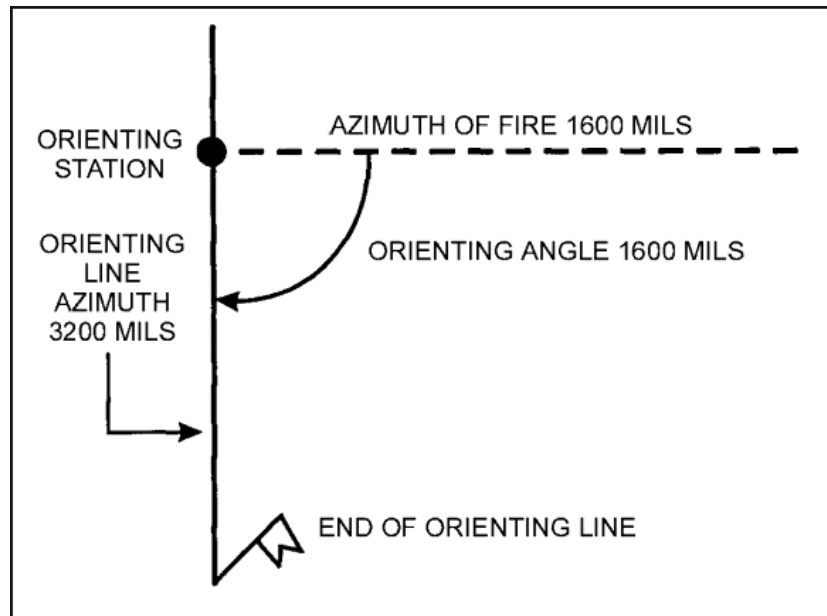

Figure 2-10. Orienting by orienting angle.

The aiming circle is set up over the orienting station by use of the plumb bob. The upper motion is used to set off 1600 mils on the aiming circle. The section leader sights on the end of the orienting line using the lower motion. The 0-3200 line of the aiming circle is now oriented.

2-16. DISASSEMBLY OF AIMING CIRCLE

Instructions for disassembling the aiming circle are located inside the circle cover.

2-17. CARE AND MAINTENANCE

The aiming circle cannot withstand rough handling or abuse. Proper care prolongs its life and ensures better results for the user. Inaccuracies or malfunctions result from mistreatment. The following precautions must be observed:

- a. Since stops are provided on instruments to limit the travel of the moving parts, do not attempt to force the rotation of any knob beyond its stop limit.
- b. Keep the instrument as clean and dry as possible. If the aiming circle is wet, dry it carefully.

- c. When not in use, keep the equipment covered and protected from dust and moisture.
- d. Do not point the telescope directly at the sun unless a filter is used; the heat of the focused rays can damage optical elements.
- e. Keep all exposed surfaces clean and dry to prevent corrosion and etching of the optical elements.
- f. To prevent excessive wear of threads and other damage to the instrument, do not tighten leveling, adjusting, and clamping screws beyond a snug contact.

Note: Only maintenance personnel are authorized to lubricate the aiming circle.

Section III. SIGHTUNITS

The M53-series and M64-series sightunits are the standard sighting devices used with the mortars. The sightunits are used to lay the mortar for elevation and deflection.

2-18. SIGHTUNIT, M53-SERIES

The sightunit, M53-series, consists of an M128 telescope mount and an M109 elbow telescope fastened together in one unit for operation (Figure 2-11). The elbow telescope provides magnification and a line of sight from which the weapon is aimed. The telescope mount secures the telescope in the correct position with respect to weapon azimuth and elevation axis).

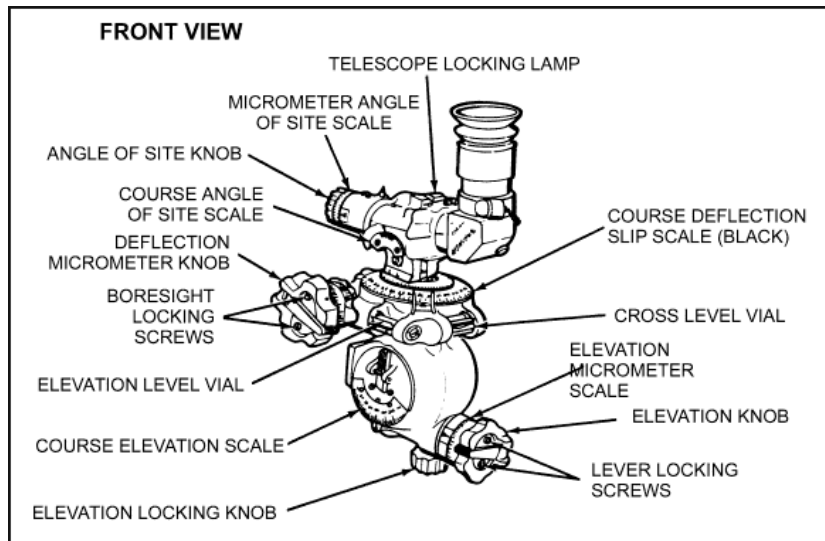

Figure 2-11. Sightunit, M53.

a. **Elbow Telescope, M109.** The elbow telescope (Figure 2-12) is a lightweight, 4-power, fixed-focus instrument with a 10-degree field of view that provides the optical line of sight for aiming the weapon in azimuth and elevation planes.

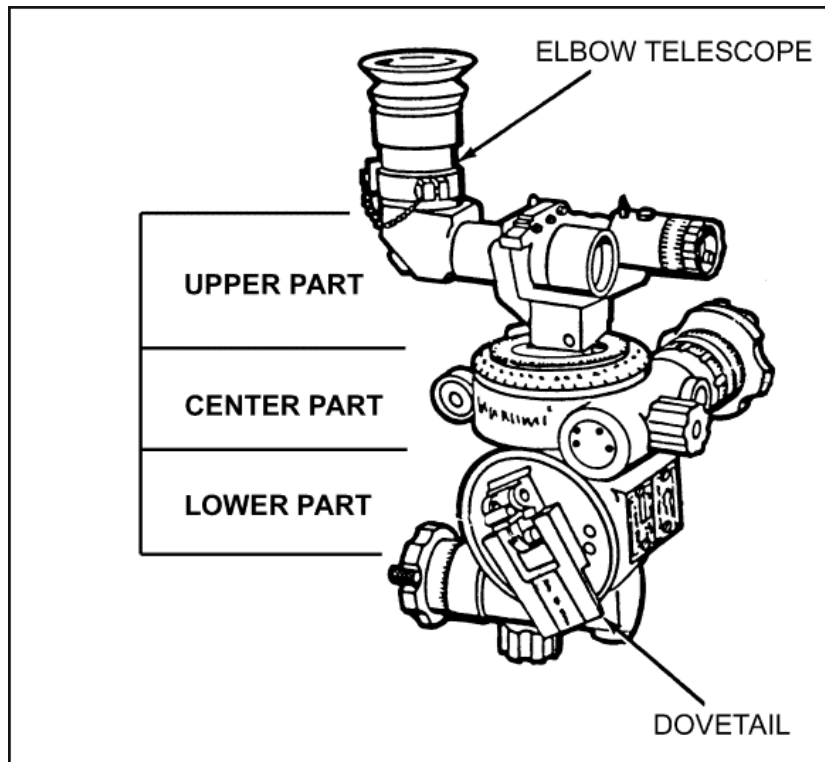

Figure 2-12. Sightunit with elbow telescope, M109.

(1) The telescope incorporates a cross- or lined-mil scale reticle that can be illuminated for night operations. The reticle pattern consists of two center lines at right angles to each other. Both center lines are graduated every 5 mils from 5 to 85 and are numbered every 10 mils in all four quadrants on both center lines.

(2) The telescope can be used in three positions: with the eyepiece to the left, right, or up. The eyepiece provides maximum comfort to the user. A telescope locking clamp permits the elbow telescope to be moved to any of the three positions and locked in these positions by the locking clamp. Indexes on the telescope and support indicate the horizontal and vertical positions of the center lines on the reticle when boresighted and the plumbed positions of the center lines. If the indexes are not lined up, the image is tilted.

(3) An angle-of-site mechanism, controlled by an angle-of-site knob, moves the telescope in a vertical plane.

b. **Telescope Mount, M128.** The telescope mount consists of three main parts: lower, center, and upper. The lower part contains a locking lever hatch, elevation micrometer knob with scales, and elevation locking knob. The center part contains a bushing for vertical axis, deflection micrometer knob and deflection locking knob, stationary and slip scales, and a pair of level vials. The upper part consists of a common horizontal axis. The telescope support is fitted with an open sight, light projection unit, and angle-of-sight knob with scales.

(1) *Lower part.* A dovetail located on the right side of the mount fits into the sight socket on the sight mount assembly to secure the sightunit to the weapon.

(a) A dual-purpose locking device in the lower section of the mount locks the dovetail of the sightunit into the sight socket of the sight mount assembly. The locking device is also used to unlock the connection between the dovetail parts for disassembly.

(b) A semicircular, course elevation scale on the left side has 18 graduations, each graduation representing 100 mils. The graduations are numbered every 200 mils, from minus 2 through 0 to 16. Negative (red) readings are for depression; positive (black) readings are for elevation settings. A reference index is inscribed on the lower part of the casting. The scale settings can be adjusted by loosening the two attaching screws, slipping the scale, and tightening the screws.

(c) The elevation knob elevates or depresses the line of sight and is fitted with a crank handle for large changes. Secured to the elevation knob is an adjustable micrometer scale consisting of positive and negative readings, numbered in black for elevation and red for depression. The scale has 100 graduations, each representing 1 mil, and is numbered every 10 mils from 0 to 90. A reference index is inscribed on the main casting. To release the scale for slipping, two screws at the front of the elevation knob must be loosened. A device controlled by a locking knob prevents the elevation knob from rotating during firing.

(2) *Center part.* The fixed deflection scale is a nonslip scale of 64 red graduations, with each 400 mils numbered in red from 0 to 60. The scale rotates with the upper part of the telescope mount when the deflection knob is turned.

(a) The deflection knob is fitted with a crank for large changes. The index for the scale is on a stationary bracket which is bolted to the main casting. The deflection micrometer scale consists of 100 red graduations numbered from 0 to 90 in increments of 10 mils. This scale is fastened to the deflection knob. To slip the micrometer scale, two screws at the front of the deflection knob must be loosened. The scale is pushed toward the sightunit and rotated to the desired setting.

(b) The coarse deflection slip scale is a large circular scale retained in place by friction and located adjacent to the fixed deflection scale. The slip scale has 64 black graduations numbered every 200 mils. The index for the scale is engraved on the main casting. The coarse deflection setting can be changed by depressing the scale and turning.

(c) The adjustable micrometer deflection slip scale, also located on the deflection knob, has 100 black graduations numbered from 0 to 90 in increments of 10 mils. The scale is retained in place by friction. The scale is fitted with an index attached to the main housing.

(d) Two level vials, located 90 degrees apart on the main housing, are used for leveling the sightunit. Both vials have rotating metal covers to protect them from damage.

(3) *Upper part.* The telescope support is equipped with an open sight, clamping mechanism, and mechanism for adjusting the angle-of-sight reading change.

2-19. OPERATION OF M53 SIGHTUNIT

Operation of the M53 sightunit is described herein.

a. **Attaching the Sightunit.** Insert the dovetail of the telescope mount into the sight socket. Press the locking lever inward, seat the mount firmly, and release the locking lever.

Note: Until the baseplate is firmly seated, remove the sight from the mortar before firing each round.

b. **Placing Sightunit Into Operation.** Place the sightunit into operation as follows:

(1) *Setting for deflection.*

(a) To place a deflection setting on the sight, turn the deflection knob. This turns the elbow telescope, the coarse deflection scales, and the deflection micrometer scales. Before attempting to place a deflection setting on the sightunit, ensure that the deflection locking knob is released. After placing a setting on the sight, lock the locking knob to lock the data onto the sight and to ensure that the scale does not slip during firing.

(b) When setting the deflection, it is necessary to use the red fixed coarse scale and the red fixed micrometer scale to obtain the desired setting. Set the first two digits of the deflection on the coarse scale and the last two on the micrometer scale.

Note: The black coarse scale and the black micrometer scale are slip scales.

(c) Setting a deflection on the deflection scale does not change the direction in which the barrel is pointing (the lay of the mortar). It only moves the vertical line off (to the left or right) the aiming line. The deflection placed on the sight is the deflection announced in the fire command. Place a deflection on the sight before elevation.

(2) Setting the elevation.

(a) To set for elevation, turn the elevation knob. This operates both the elevation micrometer and coarse elevation scales. Both scales must be set properly to obtain the desired elevation. For example, to place elevation 1065 mils on the M53 sightunit, turn the elevation knob until the fixed index opposite the moving coarse elevation scale is between the black 1000- and 1100-mil graduations on the scale (the graduations are numbered every 200 mils, from minus 2 through 0 to 16), and the 65-mil mark on the elevation micrometer is opposite the fixed index. When making elevation settings, remember that the black numbers are for elevation and the red numbers are for depression.

(b) Setting an elevation on the elevation scale does not change the elevation of the mortar barrel. The elevation to be placed on the sight is announced in the fire command.

(c) Before setting elevations on the sight, unlock the elevation locking knob. Once the elevation is placed on the sight, lock the elevation locking knob. This ensures the data placed on the sight do not accidentally change.

c. **Replacing the sightunit in the carrying case.** Before returning the sightunit to the carrying case, close the covers on the level vials and set an elevation of 800 mils and deflection of 3800 mils on the scales. Place the elbow telescope in the left horizontal position. All crank handles should be folded into the inoperative position. The M53 instrument light is stored in the same case with the rheostat knob down.

2-20. CARE AND MAINTENANCE OF M53 SIGHTUNIT

Although the M53-series sightunits are rugged, if abused or handled roughly, the unit could be inaccurate or malfunction.

- a. Avoid striking or otherwise damaging any part of the sight. Be particularly careful not to burr or dent the dovetail bracket. Avoid bumping the micrometer knobs, telescope adapter, and level vials. Except when using the sight, keep the metal vial covers closed.
- b. Keep the sight in the carrying case when not in use. Keep it as dry as possible, and do not place it in the carrying case while it is damp.
- c. When the sight fails to function correctly, return it to the DS maintenance unit for repair. Members of the mortar crew are **not** authorized to disassemble the sight.
- d. Keep the optical parts of the telescope clean and dry. Remove dust from the lens with a clean camel's-hair brush. Use only lens cleaning tissue to wipe these parts. Do not use ordinary polishing liquids, pastes, or abrasives on optical parts. Use only authorized lens cleaning compound for removing grease or oil from the lens.
- e. Occasionally oil only the sight locking devices by using a small quantity of light preservative lubricating oil. To prevent accumulation of dust and grit, wipe off excess lubricant that seeps from moving parts. Ensure that no oil gets on the deflection and elevation scales. (Oil removes the paint from the deflection scale.) No maintenance is authorized.

2-21. SIGHTUNIT, M64-SERIES

The sightunit (Figure 2-13) is the device on which the gunner sets deflection and elevation to hit targets by using the elevation level vial and the cross-level vial. After the sight has been set for deflection and elevation, the mortar is elevated or depressed until the elevation bubble on the sight is level. The mortar is then traversed until a proper sight picture is seen (using the aiming posts as the aiming point) and cross-level bubble is level. The mortar is laid for deflection and elevation when all bubbles are level. After the ammunition has been prepared, it is ready to be fired.

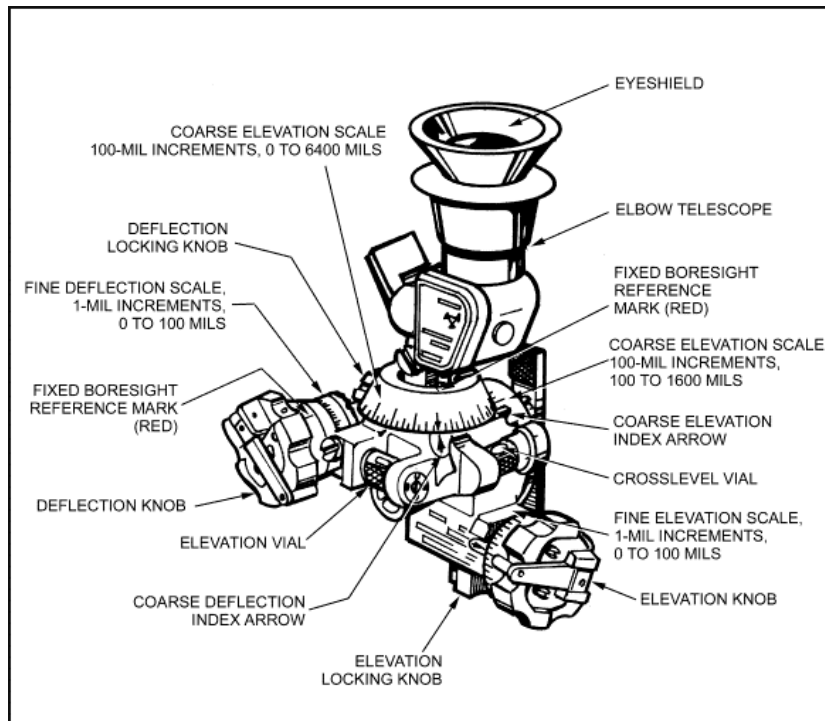

Figure 2-13. Sightunit, M64-series.

a. **Major Components.** The two major components are the elbow telescope and sight mount. The elbow telescope has an illuminated cross line. The sight mount has a dovetail, locking knobs, control knobs, scales, cranks, and locking latch.

(1) *Dovetail.* The dovetail is compatible with standard US mortars. When the dovetail is properly seated in the dovetail slot, the locking latch clicks. The locking latch is pushed toward the barrel to release the sight from the dovetail slot for removal.

(2) *Locking knobs.* The red locking knobs lock the deflection and elevation mechanisms of the sight during firing.

(3) *Micrometer knobs.* The elevation and deflection micrometer knobs are large for easy handling. Each knob has a crank for large deflection and elevation changes.

(4) *Scales.* All scales can be adjusted to any position. Micrometer scales are white. The elevation micrometer scale and fixed boresight references (red lines) above the coarse deflection scale and adjacent to the micrometer deflection scale are slipped by loosening slot-headed screws. Coarse deflection scales and micrometer deflection scales are slipped by depressing and rotating. The coarse elevation scale is factory set and should not be adjusted at crew level. (If the index does not align with the coarse elevation scale within ± 20 mils when boresighting at 800 mils, DS-level maintenance should be notified.) The screws that maintain the coarse elevation scale are held in place with locking compound. If the screws are loosened and then tightened without reapplying the locking compound, the coarse elevation scale can shift during firing.

b. **Illumination.** Instrument lights are not needed when using the sightunit at night. Nine parts of the sight are illuminated by tritium gas.

- Telescope.
- Coarse elevation scale.
- Coarse elevation index arrow.
- Elevation vial.
- Fine elevation scale.
- Coarse deflection index arrow.
- Cross-leveling vial.
- Fine deflection scale.
- Coarse deflection scale.

c. **Tabulated Data.** The tabulated data of the M64-series sightunit are as follows:

Weight: 2.5 pounds (2.2 kilograms).

Field of view: 17 degrees (302 mils).

Magnification: 1.5 unity power.

Length: 4 3/8 inches (11 centimeters).

Width: 4 3/4 inches (12 centimeters).

Height: 7 3/8 inches (19 centimeters).

Light source: Self-contained, radioactive tritium gas (H3).

CAUTION

When not in use, store the sightunit in its carrying case.

d. **Safety Precautions.** The radioactive material used in the sightunit for illumination during night operations is tritium gas (H^3), which is sealed in glass tubes. The gas is not hazardous when intact. If there is no illumination, the RPO or NBC officer should be notified.

WARNING

Do not try to repair or replace the radioactive material. If skin contact is made with tritium, wash the area immediately with nonabrasive soap and water.

(1) *Identification.* Radioactive self-luminous sources are identified by means of warning labels (Figure 2-14), which should not be defaced or removed. If necessary, they must be replaced immediately.



Figure 2-14. Warning label for tritium gas (H³).

(2) *Storage and shipping.* All radioactively illuminated instruments or modules that are defective must be evacuated to a depot maintenance activity. Defective items must be placed in a plastic bag and packed in the shipping container from which the replacement was taken. Spare equipment must be stored in the shipping container as received until installed on the weapon. Such items should be stored in an outdoor shed or unoccupied building.

Note: For information on first aid, see FM 21-11.

2-22. SIGHTUNIT, M67

The M67 sightunit (Figure 2-15) is used to lay the M120/M121 mortar for deflection and elevation. Lighting for night operations using the sightunit is provided by radioactive tritium gas contained in phosphor-coated glass vials. The sightunit is lightweight and portable. It is attached to the bipod mount by means of a dovetail. Coarse elevation and deflection scales and fine elevation and deflection scales are used in conjunction with elevation and deflection knob assemblies to sight the mortar system.

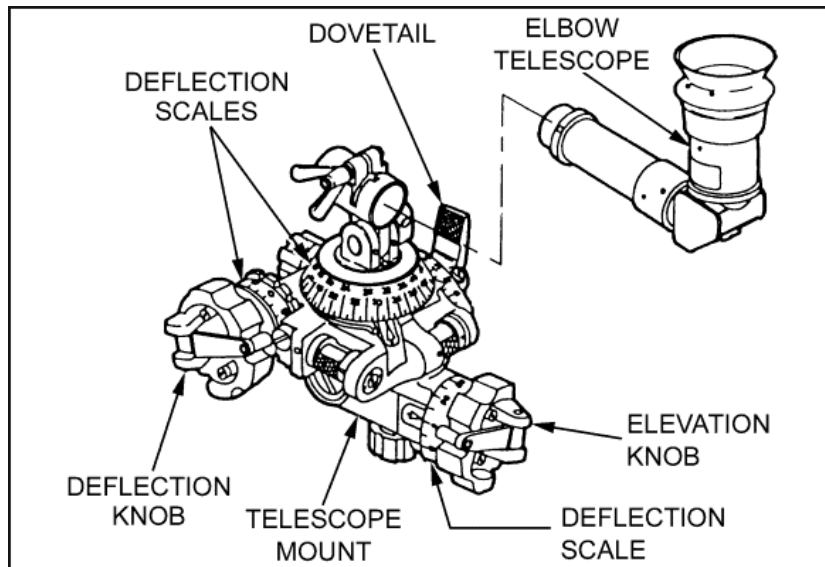

Figure 2-15. M67 sightunit.

a. **Major Components.** The M67 sightunit consists of two major components: the elbow telescope and the telescope mount.

(1) *Elbow telescope.* The elbow telescope is 4.0-power, hermetically sealed with a tritium illuminated crosshair reticle.

(2) *Telescope mount.* The telescope mount, provided with tritium back-lighted level vials, indexes, and translucent plastic scales, is used to orient the elbow telescope in azimuth and elevation.

CAUTION

When not in use, store the sightunit in its carrying case.

b. **Equipment Data.** The equipment data for the M67 sightunit are as follows:

Field of view	10 degrees
Magnification	4.0 X nominal 3.5 effective

Dimensions	4 3/8 x 5 3/8 x 8 1/2 inches (11.1 x 13.7 x 21.6 centimeters)
Illumination	Self-illuminated 6 to 8 years service life
Weight	2.9 pounds (1.3 kilograms)
Radioactive material	5.79 curies of tritium

c. **Safety Precautions.** The radioactive material used in the sightunit for illumination during night operations is tritium gas (H^3), which is sealed in glass tubes. The gas is not hazardous as long as the glass tubes are intact. If there is no illumination, the RPO or NBC officer should be notified. Radioactive self-luminous sources are identified by means of warning labels (Figure 2-14), which should not be defaced or removed. These warning labels should be replaced as necessary.

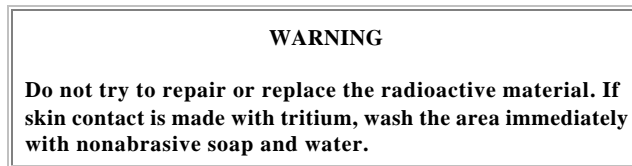

Section IV. BORESIGHTS

Boresights are adjusted by the manufacturer and should not require readjustment as a result of normal field handling.

2-23. BORESIGHT, M45-SERIES

The boresight, M45-series, detects deflection and elevation errors in the sight.

a. **Components.** The boresight, M45, (Figure 2-16) consists of an elbow telescope, telescope clamp, body, two strap assemblies, and clamp assembly.

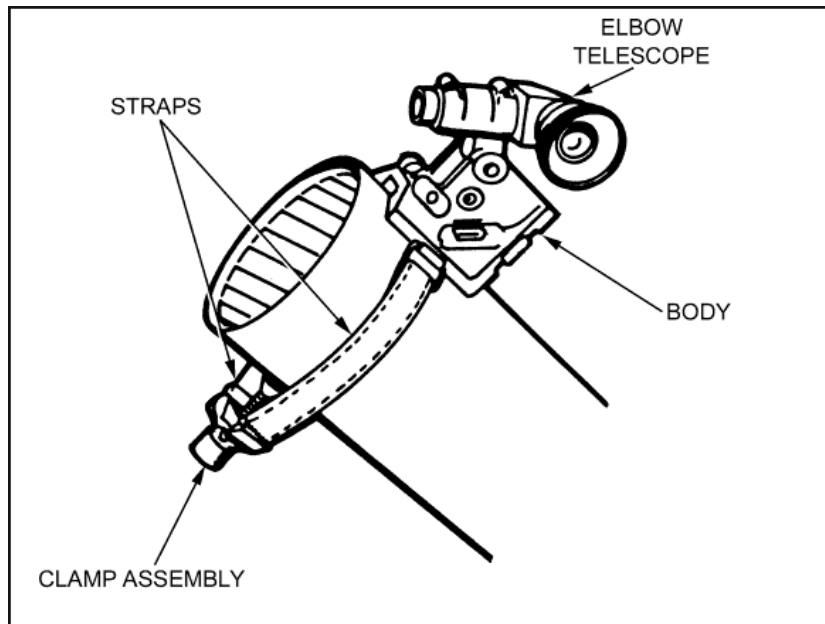

Figure 2-16. Boresight, M45.

- (1) The elbow telescope establishes a definite line of sight.
- (2) The telescope clamp maintains that line of sight in the plane established by the centerline of the V-slides.
- (3) The body incorporates two perpendicular V-slides. It contains level vials (preset at 800 mils elevation) that are used to determine the angle of elevation of 800 mils and whether the V-slides are in perpendicular positions. It also provides the hardware to which the straps are attached.
- (4) Two strap assemblies are supplied with each boresight and marked for cutting in the field to the size required for any mortar.
- (5) The clamp assembly applies tension to the strap assemblies to secure the boresight against the mortar barrel.

b. **Tabulated Data.** The tabulated data of the M45-series boresight are as follows:

Weight: 2.5 pounds

Field of View: 12 degrees
Magnification: 3 power

2-24. BORESIGHT, M115

The boresight, M115, (Figure 2-17) detects deflection and elevation errors in the sight. The boresight has three plungers that keep it in place when mounted in the muzzle of the barrel. The telescope has the same field of view and magnification as the M64-series sightunit. The elevation bubble levels only at 0800 mils.

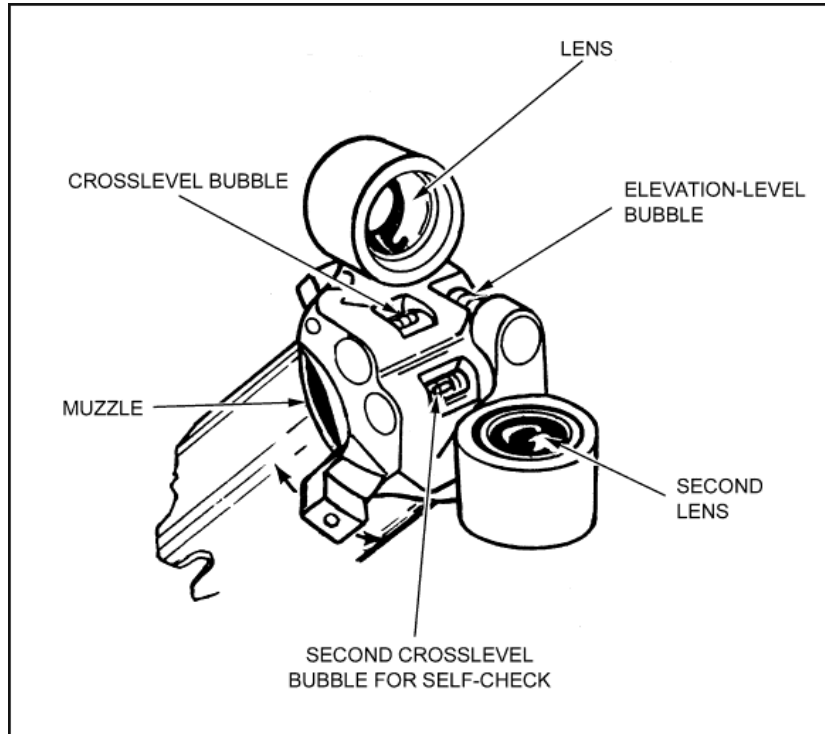

Figure 2-17. Boresight, M115.

a. **Second Cross-level Bubble.** A second cross-level bubble is used as a self-check of the M115. After leveling and cross-leveling, the M115 can be rotated 180 degrees in the muzzle until the second cross-level bubble is centered. The

image of the boresight target should not vary in deflection. A large deviation indicates misalignment between the cross-level bubble and lenses.

b. **Components.** The components of the M115 boresight are the body, telescope, and leveling bubbles (one for cross-leveling and one for elevation).

c. **Tabulated Data.** The tabulated data of the M115 boresight are as follows:

Weight:	5 ounces
Field of view:	17 degrees
Magnification:	1.5 power

2-25. PRINCIPLES OF OPERATION

The boresight is constructed so that the telescope line of sight lies in the plane established by the center lines of the V-slides. When properly secured to a mortar barrel, the centerline of the contacting V-slide is parallel to the centerline of the barrel. Further, the cross-level vial, when centered, indicates that the center lines of both slides, the elbow telescope, and the barrel lie in the same vertical plane. Therefore, the line of sight of the telescope coincides with the axis of the barrel, regardless of which V-slide of the boresight is contacting the barrel. The elevation vial is constructed with a fixed elevation of 800 mils.

2-26. INSTALLATION

Installation procedures for the M45 boresight are described herein.

- a. Remove the boresight, clamp assembly, and straps from the carrying case. Grasp the boresight by the body to prevent damaging the telescope.
- b. Place the ring over the hook and attach the strap snap to the eye provided on the strap shaft.
- c. If necessary, release the catches and reset the straps to the proper length.
- d. Remove any burrs or projecting imperfections from the seating area of the mortar barrel to ensure proper seating of the boresight. Attach the boresight to the barrel below and touching the upper stop band on the M252 mortar. However, attach the boresight about 1 inch from the muzzle of the barrel on all other mortars.

Note: For further information, see TM 9-1240-278-12.

2-27. SIGHT CALIBRATION

Always calibrate the mortar sight to the mortar on which it is to be mounted. This procedure is necessary since the sight socket that receives the sightunit is a machined part and varies in accuracy with each mortar. There is no set rule for frequency of calibration. The sight should be calibrated each time the mortar is mounted in a new location, since the movement might disturb the setting of the elevation and deflection scales. Time available and accuracy dictate the frequency of calibration.

2-28. BORESIGHT METHOD OF CALIBRATION

Once the mortar has been mounted, place the M53-, M64-, or M67-series sightunit into position in the sight socket. Using the M53- (fixed deflection [red] scale), the M64-, or the M67-series sightunit, place a deflection of 3200 mils and an elevation of 0800 mils on the scales. For the M252 mortar, place a deflection of 0 mils on the sight. Align the vertical cross line of the sight on an aiming point (at least 200 meters distant) by shifting the bridge assembly or bipod. If necessary use the traversing mechanism; however, keep the mortar within two turns of center of traverse (four turns of center of traverse for the 120-mm mortar). Make a visual check of the mortar for cant; if cant exists, remove this cant and re-lay, if necessary.

Note: For a detailed discussion of the boresight method of calibration, see applicable TM.

a. Elevation Setting.

- (1) Install the boresight on the mortar barrel. Center the cross-level vial by rotating the boresight slightly around the outside diameter of the mortar barrel. Slight movements are made by loosening the clamp screw and lightly tapping the boresight body. When the bubble centers, tighten the clamp screw.
- (2) Elevate or depress the mortar barrel until the boresight elevation level vial is centered. The mortar is now set at 800 mils (45 degrees) elevation.
- (3) Using the elevation micrometer knob, elevate or lower the sightunit until the elevation level bubble is centered. If necessary, cross-level the sightunit.
- (4) Recheck all level bubbles.
- (5) The reading on the coarse elevation scale of the sightunit should be 800 mils and the reading on the elevation micrometer scale should be 0. If adjustment is necessary, proceed as indicated below.
 - (a) Loosen the two screws that secure the coarse elevation scale and slip the scale (for the M53-series sightunit only) until the 800-

mil mark on the scale coincides with the reference mark on the housing. Tighten the two screws to secure the scales.

Note: Do not adjust the M64-series sightunit coarse elevation scale. If it does not line up with the 0800-mil mark, turn it in to DS maintenance.

(b) Loosen the two screws on the elevation micrometer knob and slip the elevation micrometer scale until the 0 mark on the micrometer scale coincides with the reference mark on the housing. Tighten the two screws to secure the micrometer scale.

(6) Recheck all level bubbles.

b. Deflection Setting.

(1) Check again to ensure that the sight setting reads 3200 on the fixed deflection (red) scale and elevation 800 mils. Set zero deflection for the M252 mortar.

(2) Traverse the mortar no more than two turns of center of traverse (four turns for the 120-mm mortar) and align the vertical cross line of the boresight on the original aiming point. Adjust the boresight to keep the cross-level bubble centered since the mortar could cant during traversing. (If the mortar is initially mounted on the aiming point, it decreases the amount of traverse needed to align the cross line on the aiming point.) Also, the elevation level bubble may need to be leveled.

(3) After the boresight is aligned on the aiming point, level the sight by centering the cross-level bubble. Rotate the deflection micrometer knob until the sight is aligned on the aiming point. The coarse deflection scale should read 3200 mils and the micrometer scales should read 0. If adjustment is necessary, loosen the two screws on the deflection micrometer knob and slip the micrometer deflection scale until the arrow on the index is aligned with the zero mark on the micrometer scale.

(4) To ensure proper alignment, remove and place the boresight in position underneath the barrel as shown in Figure 2-18. Center the boresight cross-level bubble and check the vertical cross line to see if it is still on the aiming point. If cant exists, the vertical cross line of the boresight is not on the aiming point. This indicates that the true axis of the bore lies halfway between the aiming point and where the boresight is now pointing.

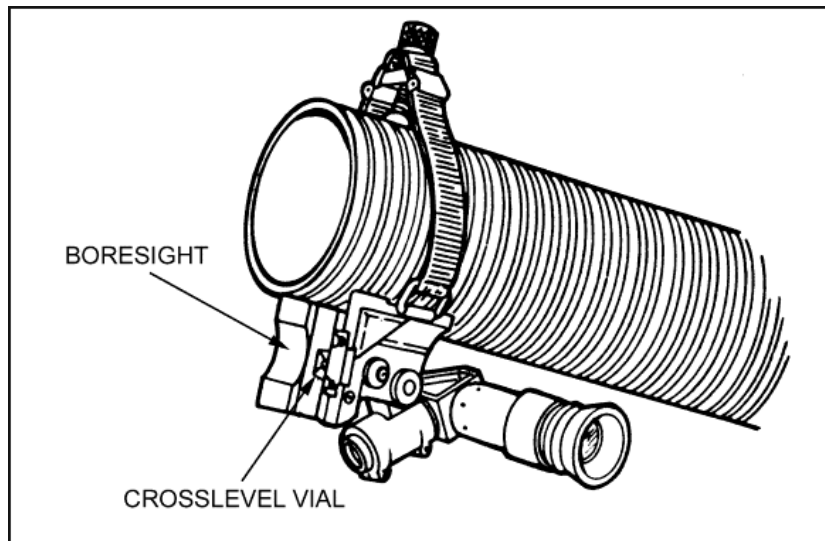

Figure 2-18. Checking for proper alignment with the boresight device.

(5) To correct this error, look through the boresight, traverse the mortar onto the aiming point. If bubbles are level, use the deflection micrometer knob and place the vertical cross line of the sight back onto the aiming point. With the sight in this position, index one-half of the mil variation between the sight and boresight. Slip zero on the micrometer scale to the index mark--for example, the mil variation is 10 mils and one-half of this value is 5 mils. Loosen the two screws on the deflection micrometer and index zero.

(6) Check all level bubbles, sightunit, and boresight.

(7) With a deflection on the micrometer scale of half the value of the original mil variation, both the sightunit and boresight are on the aiming point. If an error exists, repeat the procedure outlined above.

(8) Using the M64-series sightunit, adjust the deflection scale and micrometer scale of the sightunit to zero. To do this, loosen the deflection knob screws and slip the scale to zero. Adjust the deflection micrometer scale to zero by pushing in on the micrometer knob retaining button and slipping the scale to zero.

(9) Check again all level bubbles, and the lay of the sightunit and the boresight on the aiming point.

Note: The M53-series sightunit should be received from the manufacturer with the red deflection scale calibrated on 3200. If it is not, turn the sightunit in to DS maintenance for calibration.

c. Removal.

- (1) Loosen the clamp screw, releasing the boresight from the barrel.
- (2) Swing the elbow telescope until it is about parallel with the elevation level bubble.
- (3) Release the clamp assembly and straps by removing the ring from the hook and strap shaft.
- (4) Stow the clamp assembly and straps in the corner compartment. Put the boresight in the center compartment of the carrying case.

2-29. CALIBRATION FOR DEFLECTION USING THE M2 AIMING CIRCLE

Two methods can be used to calibrate the sight for deflection using the M2 aiming circle: the angle method (Figure 2-19) and the distant aiming point method (Figure 2-20).

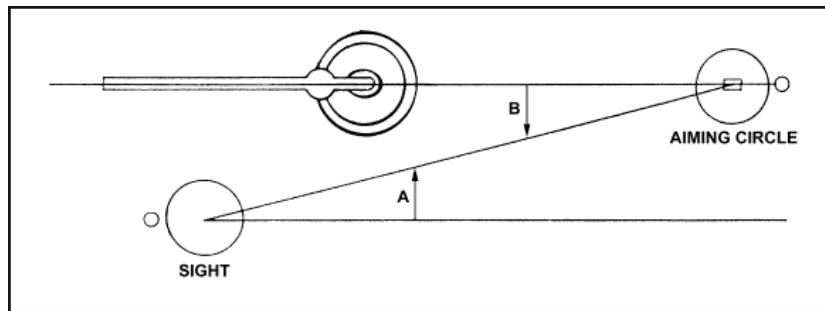

Figure 2-19. Calibration for deflection using the angle method.

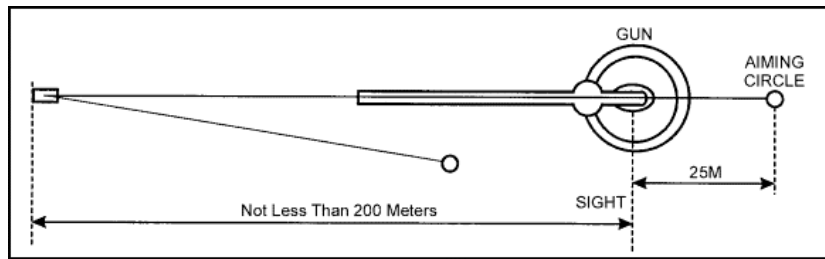

Figure 2-20. Calibration for deflection using the distant aiming point method.

a. Calibration for Deflection Using the Angle Method.

- (1) Set up the aiming circle 25 meters to the rear of the mounted mortar. (The mortar is mounted at 800 mils elevation.)
- (2) With the aiming circle fine leveled, index 0 on the azimuth scale and azimuth micrometer scale. Using the orienting motion (nonrecording motion) align the vertical line of the reticle of the telescope so that it bisects the baseplate.
- (3) Traverse and cross-level the mortar until the center axis of the barrel from the baseplate to the muzzle is aligned with the vertical line of the aiming circle telescope reticle.
- (4) Turn the deflection knob of the sight until the vertical line is centered on the lens of the aiming circle and read angle A, opposite the fixed index.
- (5) Turn the azimuth micrometer knob of the aiming circle until the vertical line of the telescope is laid on the center of the sight lens and read angle B, opposite the azimuth scale index. If the sight is in calibration, angles A and B will be equal. If they are not equal the sight is adjusted by loosening the two screws in the face of the deflection knob of the sight and slipping the micrometer deflection scale until the scale is indexed at the same reading as angle B of the aiming circle.

b. Calibration for Deflection Using the Aiming Point Method.

- (1) Set up the aiming circle and fine level. Align the vertical line of the telescope on a distant aiming point (a sharp, distinct object not less than 200 meters in distance).
- (2) Move the mortar baseplate until the baseplate is bisected by the vertical line of the telescope of the aiming circle. Mount the mortar at an elevation of 800 mils. Traverse and cross-level the mortar until the axis of

the barrel from the baseplate to the muzzle is bisected by the vertical line of the aiming circle (the mortar should be mounted about 25 meters from the aiming circle).

Note: Indexing the aiming circle at 0 is not necessary; only the vertical line is used to align the mortar with the distant aiming point.

(3) The aiming circle operator moves to the mortar and lays the vertical line of the sight on the same distant aiming point. If the sight is calibrated, the deflection scales of the sight are slipped to a reading of 3200.

Section V. OTHER EQUIPMENT

Other equipment required to operate and employ mortars are discussed in this section.

2-30. INSTRUMENT LIGHT, M53E1

The instrument light (Figure 2-21) illuminates the reticle of the M109 elbow telescope and scales of the M128 telescope mount during night operations. This instrument light is the standard night light used with the 4.2-inch and 120-mm mortars.

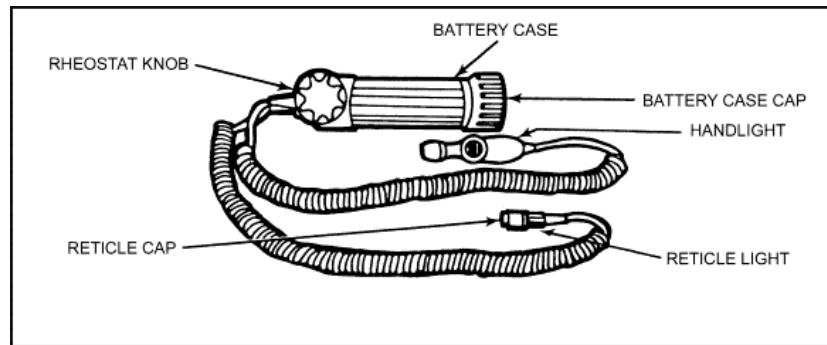

Figure 2-21. Instrument light, M53E1.

a. The light consists of mainly two flashlight batteries, battery case, rheostat knob, and two separate light assemblies attached to a pair of flexible lead wires that extend from one end of the battery case. Because the wires are coiled, the leads can be extended from a normal length of 2 feet to about 6 feet.

b. One light assembly consists of a bracket assembly that can be screwed into the lamp bracket holder for lighting the elbow telescope reticle. This light is turned on/off by the rheostat knob. The knob is also used to increase or decrease the

intensity of the illumination. The second light assembly is a hand light that can be directed upon the telescope mount scales or the level vials as required. The on/off switch for this light is located on the hand light.

c. To place the instrument light into operation (Figure 2-22), the cap is pressed inward at the end of the battery case and turned counterclockwise until free. Two BA-30 batteries are inserted terminal ends first. The cap is installed by turning clockwise until finger tight. Install the battery case of the light in the carrying case with the rheostat knob accessible. The carrying case is positioned so the lead wires reach the sightunit. The dust cover is removed from the lamp bracket holder of the M109 elbow telescope, and the protective cap is removed from the end of the light assembly lead. The end of the light assembly is threaded into the socket on the elbow telescope for illuminating the telescope reticle. The hand light is retained in the case until required for use. **DO NOT ATTEMPT TO USE THE M53 LIGHT ON THE LIGHT PROJECTOR OF THE M53 SIGHT.**

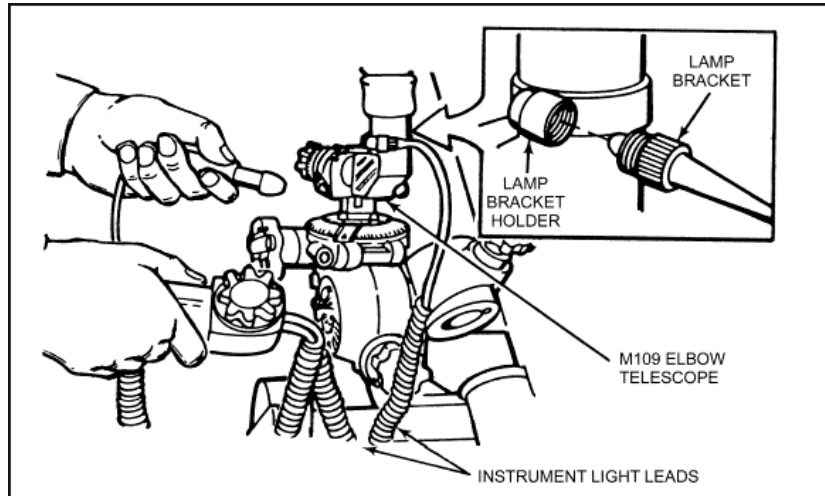

Figure 2-22. Installation of instrument light.

d. The M166 carrying case is a lightweight, sturdy case with an isofoam bed that provides storage for the M53 sightunit and the M53 instrument light (Figure 2-23).

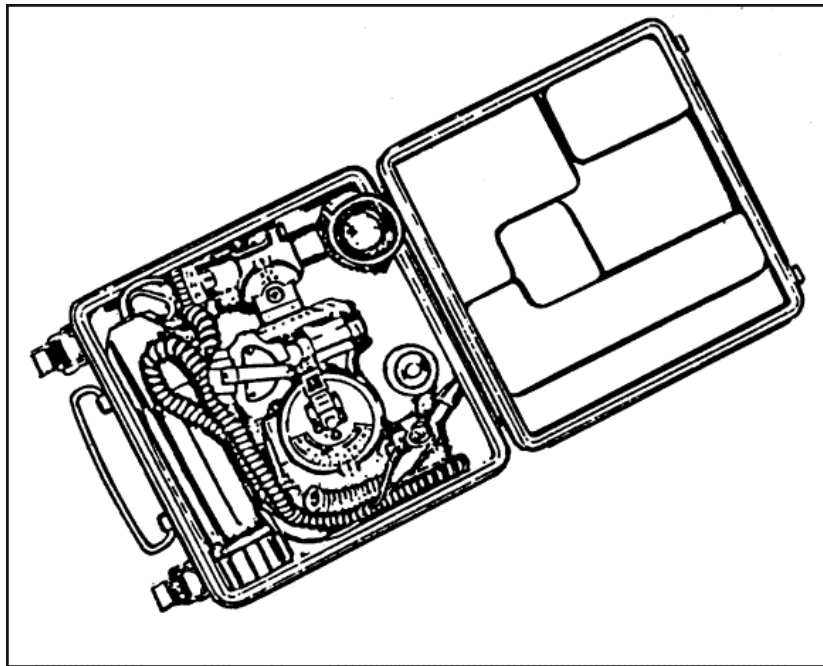

Figure 2-23. Carrying case, M166.

2-31. AIMING POSTS, M14 and M1A2

The M14 aiming posts (Figure 2-24) are used to establish an aiming point (reference line) when laying the mortar for deflection. They are made of aluminum tubing and have a pointed tip on one end. Aiming posts have red and white stripes so they can be easily seen through the sight. The M14 aiming post comes in a set of eight segments, plus a weighted stake for every 16 segments to be used as a driver in hard soil. The stake has a point on each end and, after emplacement, it can be mounted with an aiming post. The segments can be stacked from tip to tail, and they are carried in a specially designed case with a compartment for each segment. Four M1A2 aiming posts are provided with the mortar. They may be stacked end to end (two at most).

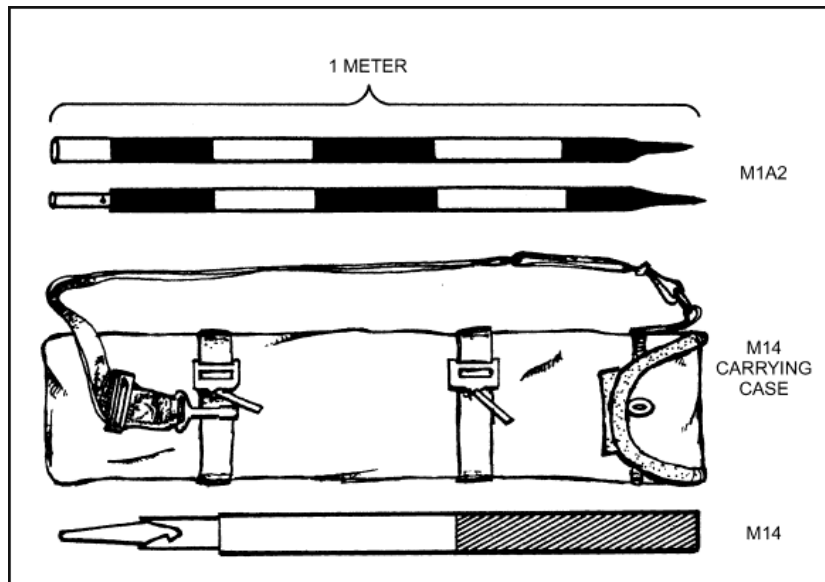

Figure 2-24. Aiming posts, M14 and M1A2.

2-32. AIMING POST LIGHTS, M58 and M59

Aiming post lights (Figure 2-25) are attached to the aiming posts so they can be seen at night through the sight. The near post must have a different color light than that of the far post. Aiming post lights come in sets of three--two green (M58) and one orange (M59). An extra third light is issued for the alternate aiming post. Each light has a clamp, tightened with a wing nut, for attachment to the aiming post. The light does not have a cover for protection when not in use and does not need batteries.

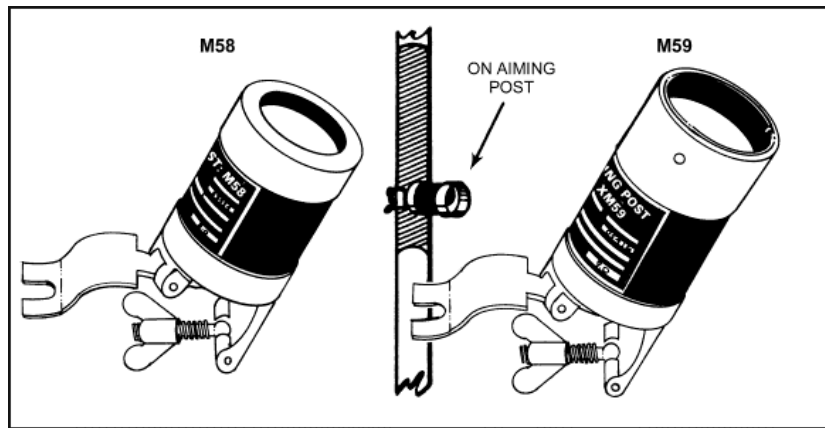

Figure 2-25. Aiming post lights, M58 and M59.

WARNING

Radioactive material (tritium gas [H3]) is used in the M58 and M59 aiming post lights. Radioactive leakage may occur if M58 and M59 aiming post lights are broken or damaged. If exposed to a broken or damaged M58 or M59 aiming post light or if skin contact is made with any area contaminated with tritium, immediately wash with nonabrasive soap and water, and notify the local RPO.

Section VI. LAYING THE SECTION

When all mortars in the section are mounted, the section leader lays the section parallel on the prescribed azimuth with an aiming circle. The mortar section normally fires a parallel sheaf (Figure 2-26). To obtain this sheaf, it is necessary to lay the mortars parallel. When a section moves into a firing position, the FDC determines the azimuth on which the section is to be laid and notifies the platoon sergeant (section sergeant). Before laying the mortars parallel, the section leader must calibrate the mortar sights. All mortars are then laid parallel using the aiming circle, mortar sight, or compass. The section is normally laid parallel by following two steps:

- STEP 1: Establish the 0-3200 line of the aiming circle parallel to the mounting azimuth.
- STEP 2: Lay the section parallel to the 0-3200 line of the aiming circle.

2: (reciprocal laying).

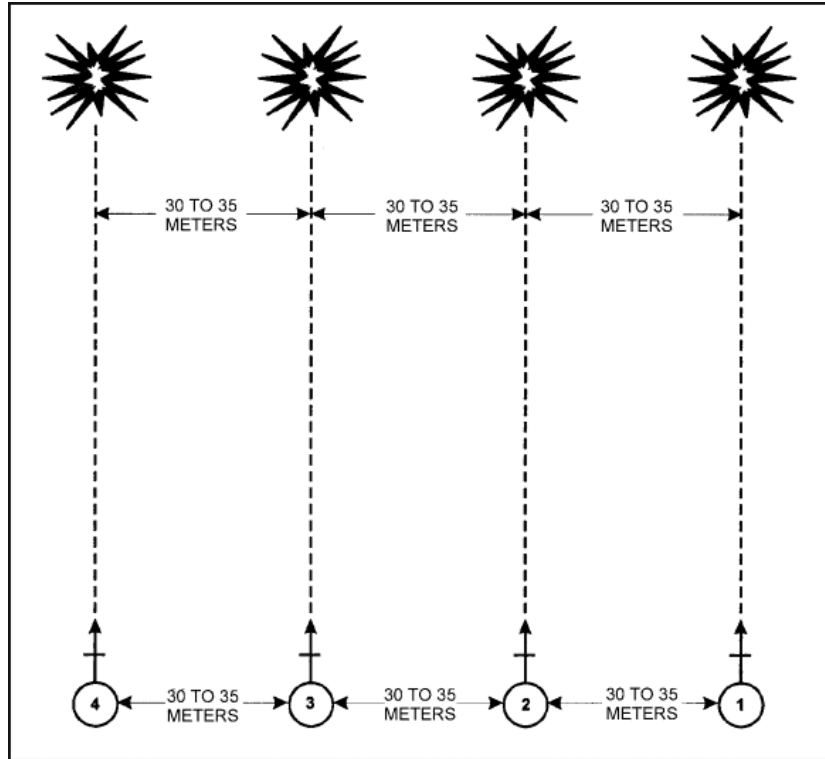

Figure 2-26. Parallel sheaf.

2-33. RECIPROCAL LAYING

Reciprocal laying is a procedure by which the 0-3200 line of one instrument (aiming circle) and the 0-3200 line of another instrument (sightunit) are laid parallel (Figure 2-27). When the 0-3200 lines of an aiming circle and the 0-3200 line of the sightunit are parallel, the barrel is parallel to both 0-3200 lines, if the sight has been properly calibrated. The principle of reciprocal laying is based on the geometric theorem that states if two parallel lines are cut by a transversal, the alternate interior angles are equal. The parallel lines are the 0-3200 lines of the instruments, and the transversal is the line of sight between the two instruments. The alternate interior angles are the equal deflections placed on the instruments

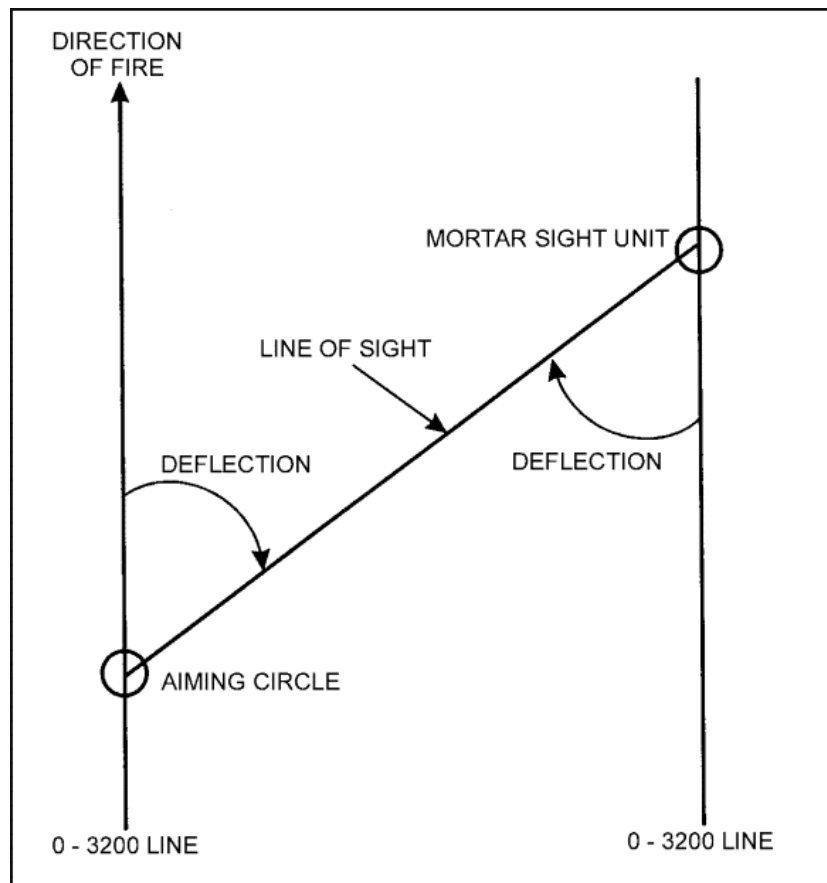

Figure 2-27. Principles of reciprocal laying.

a. Orient the aiming circle so that the 0-3200 line of the aiming circle is parallel to the mounting azimuth. The section leader announces to the mortar gunners (either by voice or visual signal), "Section, aiming point this instrument." The gunners turn their sights until the vertical cross line of the sight is sighted on the lens of the aiming circle and the mortar is level. The gunners announce (either by voice or visual signal), "Number (1, 2, and so on), aiming point identified." The section leader, using the upper motion, sights on the lens of the sightunit, reads the deflection on the azimuth micrometer scales, and announces the deflection to the gunner on the mortar. The gunner sets the deflection on the sightunit and causes

the mortar to be moved until the vertical cross line of the sight is sighted on the lens of the aiming circle and the mortar is level.

b. When the sight has been sighted on the aiming circle, the gunner reports, "Ready for recheck." The platoon sergeant (section sergeant) again sights on the lens of the sightunit, and reads and announces the deflection. This procedure is repeated until the gunner reports a difference of ZERO (or ONE) MIL between successive deflections. The mortar has then been laid.

2-34. RECIPROCAL LAYING ON A GRID AZIMUTH

This paragraph discusses the commands and procedures used in reciprocal laying of the mortar section on a given grid azimuth.

a. The FDC normally directs the section to lay the mortar parallel on a mounting (grid) azimuth.

b. The platoon sergeant (section sergeant) receives the command MOUNTING AZIMUTH FIVE FIVE FIVE ZERO (5550 mils) from the FDC.

(1) The mounting azimuth is 5550 mils, and the aiming circle has a declination constant of 450 mils.

Declination constant	450 mils
	+ <u>6400 mils</u>
	6850 mils
Minus the mounting (grid) azimuth	- <u>5550 mils</u>
Remainder to set on aiming circle	1300 mils

(2) The platoon sergeant (section sergeant) mounts and levels the aiming circle at a point from which he can observe the sights of all the mortars in the section (normally the left front or left rear of the section).

(3) He places 1300 mils on the azimuth and micrometer scales of the aiming circle (recording motion).

(4) Using the orienting knob, he centers the magnetic needle in the magnetic needle magnifier. This orients the 0-3200 line of the aiming circle in the desired direction (mounting azimuth 5550 mils).

(5) The platoon sergeant (section sergeant) announces, "Section, aiming point this instrument."

(6) All gunners refer their sights to the aiming circle with the vertical cross line laid on the center of the aiming circle. The gunner then announces, "Number two (one or three), aiming point identified."

(7) To lay the mortar barrel parallel to the 0-3200 line of the aiming circle (Figure 2-28), the platoon sergeant (section sergeant) turns the upper motion of the aiming circle until the vertical cross line is laid on the center of the lens of the mortar sight. He reads the azimuth and micrometer scales and announces the deflection. For example, "Number two, deflection one nine nine eight (1998)."

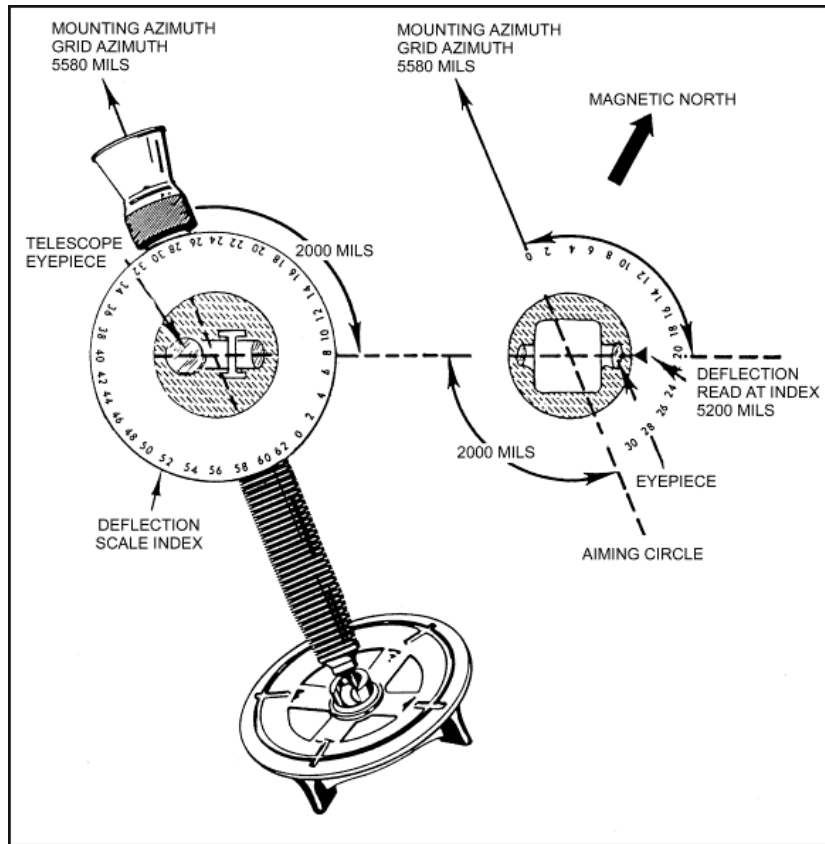

Figure 2-28. Mortar laid parallel with the aiming circle.

Note: When the M53 sightunit is used, it is calibrated at 3200 mils on the red deflection and micrometer scales. All readings from the aiming circle to the sight are placed on the red deflection scale and the mortar is laid on the aiming circle using this scale.

(8) The gunner repeats the announced deflection, "Number two, deflection one nine nine eight," and places it on his sight. Assisted by the assistant gunner, he lays the mortar so that the vertical line is once again laid on the center of the aiming circle after the gunner announces, "Number two, ready for recheck."

(9) Using the upper motion, the platoon sergeant (section sergeant) again lays the vertical cross line of the aiming circle on the lens of the mortar sight. He reads the new deflection from the azimuth and micrometer scales and announces the reading--for example, "Number two, deflection two zero zero zero."

(10) The gunner repeats the new deflection (Number two, deflection two zero zero zero) and places it on his sight. Assisted by the assistant gunner, he lays the mortar with the vertical cross line of the sight on the center of the aiming circle and announces, "Number two, ready for recheck."

(11) The above procedure is repeated until the mortar sight and aiming circle are sighted on each other with a difference of not more than ONE mil between the deflection readings. When so laid, the gunner announces, "Number two (one or three), zero mils (one mil), mortar laid." The mortar barrel is now laid parallel to the 0-3200 line of the aiming circle.

(12) The platoon sergeant (section sergeant) uses the same procedure to lay each of the other mortars in the section parallel. When all mortars are parallel to the 0-3200 line of the aiming circle, they are parallel to each other and laid in the desired azimuth (Figure 2-29).

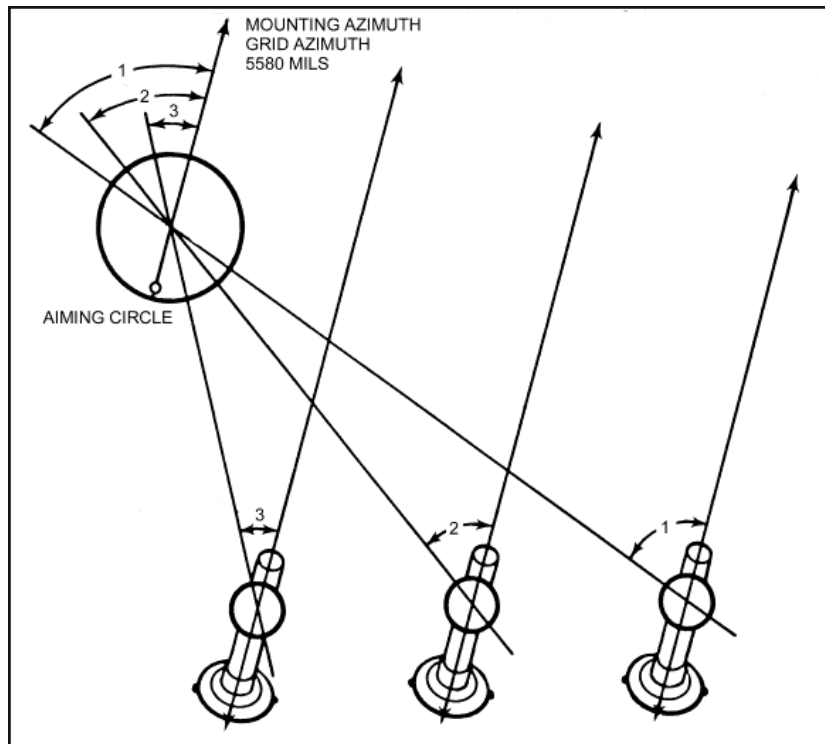

Figure 2-29. Mortars laid parallel in the desired azimuth.

Note: The section can be laid parallel by laying all mortars at the same time. The instrument operator reads deflections to each of the mortars in turn. As soon as the gunner of any mortar announces, "Ready for recheck," the instrument operator reads the new deflection to that mortar. By laying all mortars at the same time, the section is quickly ready to fire.

(13) As soon as each mortar is laid, the platoon sergeant (section sergeant) commands DEFLECTION TWO EIGHT ZERO ZERO (2800), REFER, PLACE OUT AIMING POSTS. (The aiming posts are normally placed out on a referred deflection of 2800 mils.) The gunner, without disturbing the lay of the mortar, places the announced deflection on his sight and aligns the aiming posts with the vertical line of the mortar sight. He then announces, "Up."

(14) When all mortar gunners announce, "Up," the instrument operator covers the head of the aiming circle, but leaves the instrument in position to permit a rapid recheck of any mortar, if necessary.

2-35. RECIPROCAL LAYING ON A MAGNETIC AZIMUTH

Although the section is normally laid parallel on a grid azimuth, it can be laid parallel on a magnetic azimuth by subtracting the magnetic mounting azimuth from 6400 mils and by setting the remainder on the azimuth and micrometer scales of the aiming circle. The section leader orients the instrument and lays the section.

2-36. RECIPROCAL LAYING USING THE ORIENTING ANGLE

The mortars of each section can be laid parallel more accurately if the instrument operator lays the section parallel by using the orienting angle. He sets up and levels the aiming circle; orients the aiming circle, and lays the section.

2-37. RECIPROCAL LAYING USING THE MORTAR SIGHTS

The mortar section can be laid parallel by using the mortar sights. For this method, it is best to have the mortars positioned so that all sights are visible from the base mortar. The base mortar (normally No. 2) is laid in the desired direction of fire by compass or by registration on a known point. After the base mortar is laid for direction, the remaining mortars are laid parallel to the base mortar as follows:

- a. The platoon sergeant (section sergeant) moves to the mortar sight of the base mortar and commands SECTION, AIMING POINT THIS INSTRUMENT. The gunners of the other mortars refer their sights to the sight of the base mortar and announce, "Aiming point identified."
- b. The platoon sergeant reads the deflection from the red scale on the sight of the base mortar. He then determines the back azimuth of that deflection and announces it to the other gunners.

Note: A back azimuth is determined by adding or subtracting 3200 to the initial deflection--for example, "Number three, deflection one two zero zero."

- c. Each gunner repeats the announced deflection for his mortar, places the deflection on his sight (using the red fixed scale), and re-lays on the sight of the base mortar. When the lens of the base mortar sight is not visible, the gunner lays the vertical cross line of his sight on one of the other three mortar sights (Figure 2-30). He is laid in by this mortar once it is parallel to the base mortar sightunit. He then announces, "Number one (or three), ready for recheck."

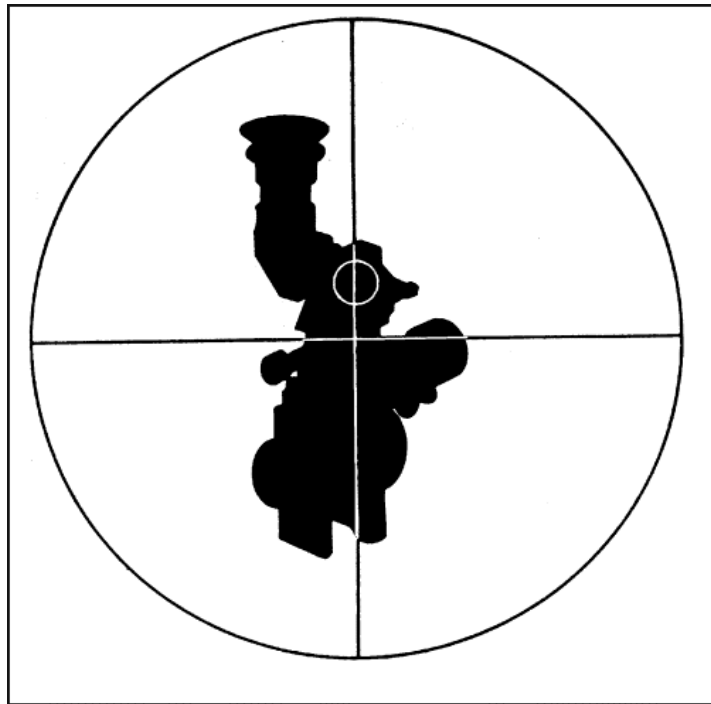

Figure 2-30. Sighting on the mortar sight.

d. After each mortar has been laid parallel within zero (or one mil), the mortar barrels are parallel to the base mortar (Figure 2-31).

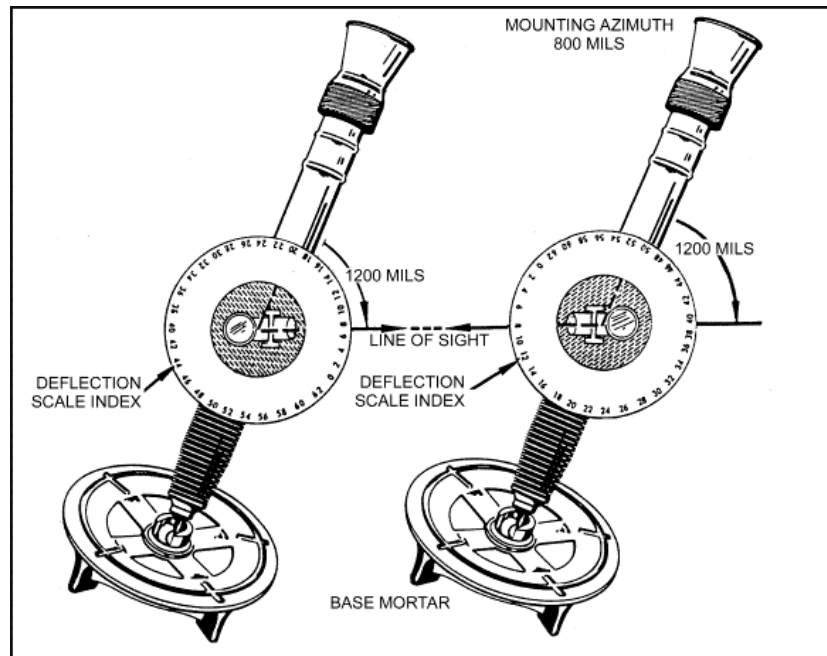

Figure 2-31. Mortar laid parallel with sights.

e. As soon as each mortar is laid, the platoon sergeant (section sergeant) commands NUMBER THREE, DEFLECTION TWO EIGHT ZERO ZERO (2800), REFER, PLACE OUT AIMING POSTS.

2-38. RECIPROCAL LAYING USING THE M2 COMPASS

A rapid means of laying the section parallel is by using the compass. This is an alternate means and is used only when an aiming circle is not available or when time dictates. It is not as accurate as the methods previously described.

- a. Before mounting the mortars, each squad leader places a base stake in the ground to mark the approximate location of the mortar.
- b. The platoon sergeant (section sergeant) announces the desired mounting azimuth--for example, "Mount mortars, magnetic azimuth two two one two."
- c. Each squad leader places his compass on the base stake marking the location of his mortar, and orients the compass on the desired mounting azimuth. By sighting

through the compass, he directs the second ammunition bearer in aligning the aiming posts along the mounting (magnetic) azimuth.

d. Each mortar is then mounted and laid on the aiming posts with a deflection of 3200 (zero on the M64-series sight) placed on the sight. If no mechanical or human error exists, the mortar barrels are now laid parallel. (This is normally not true, however, since both mechanical and human error usually exist.)

Note: Recognizing the difference in individual compasses, the platoon sergeant (section sergeant) can prescribe that all mortars be laid with one compass. This eliminates some mechanical error. It is also possible to lay only the base mortar as described above and then lay the remaining mortars parallel using the mortar sight method. The compass method is used only when the aiming circle or mortar sight method is not practical.

2-39. PLACING OUT AIMING POSTS

When a firing position is occupied, the gunner must determine in which direction the aiming posts are to be placed out. Factors to consider are terrain, sight blockage, and traffic patterns in the section area. If possible, the aiming posts should be placed out to the left front. This direction gives a large latitude in deflection change before sight blockage occurs. Also, the aiming posts do not interfere with the traffic pattern of troops and vehicles within the section area. Under normal conditions the front aiming post is placed out 50 meters and the far aiming post 100 meters.

a. When the black deflection scales and red line scales numerically coincide, local terrain features may not permit placing out the aiming posts at a referred deflection of 2800 mils. When this occurs, the following procedure is used:

Note: This is constant only with the M64 sightunit.

- (1) Determine the general direction to properly place out aiming posts that allows a maximum traverse before encountering a sight block.
 - (2) Refer the sight to that general direction and index any deflection to the nearest 100 mils.
 - (3) Place out the aiming posts.
 - (4) Record the deflection reading on the red scales.
- b. The black deflection scale of the M64 sightunit must be slipped when the mortar section is being used in a 6400-mil capability.

(1) After the mortar is initially laid for direction, rotate the deflection micrometer knob until the deflection scale is set on 2800 mils. Place out two aiming posts to the left front.

(2) Using the deflection course scale, index a deflection of 700 mils and place out two more aiming posts to the right rear.

(3) Be sure to use ONLY the aiming posts placed out at 2800 mils for the front reference points. Use the aiming posts placed out at 700 mils for the rear reference points.

Note: To ensure that the gunners are on the appropriate aiming posts, the section leader may direct that each mortar squad place out cardinal direction stakes around its mortar position. He should also announce the general direction of fire before giving the initial fire command.

c. When the M64 sightunit is used within the same firing section that is being used in a 6400-mil capability, the gunner must slip the black deflection scale of the sightunit so that 0 mils on the black deflection scale coincides with the red 3200-mil line.

d. When the section is laid parallel, the rounds usually land in the impact area the same distance apart as the mortars are mounted (25 to 30 meters). When they do not, the FO must adjust the sheaf.

(1) Sheaf adjustment is normally accomplished after the base mortar is adjusted on the registration point. The section leader has the section fire a section right (left) with the same charge and deflection setting as the base mortar (No. 2). The FO adjusts mortar No. 1 until it is in its proper position in the sheaf. Any adjustment of either mortar results in that mortar having a different deflection. This makes it necessary to announce a different deflection for each mortar to fire two mortars as a section. To avoid that complication, the sights are referred so that each sight has the same deflection reading.

(2) At the completion of the adjustment, the FDC commands SECTION, REFER DEFLECTION, (FDC gives the deflection of the base No. 2 mortar), REALIGN AIMING POSTS. The gunner refers his sight to the deflection setting and, without disturbing the lay of the mortar, directs the ammunition bearer in moving the aiming posts until they are aligned with the vertical cross line of the sight. The barrels of the mortars are parallel, and each mortar has the same deflection reading.

2-40. ALTERNATE METHOD OF PLACING OUT AIMING POSTS

After the section leader has laid the section for direction, he commands SECTION, REFER DEFLECTION (normally, TWO EIGHT ZERO ZERO), PLACE OUT AIMING POSTS. The gunner determines which general direction will enable him to place out his aiming posts and still allow a maximum traverse before encountering a sight block. He refers the sight to that direction and indexes any deflection to the nearest 100 mils. He then places out the aiming posts, assisted by the ammunition bearer, and informs the section leader of his deflection (Figure 2-32).

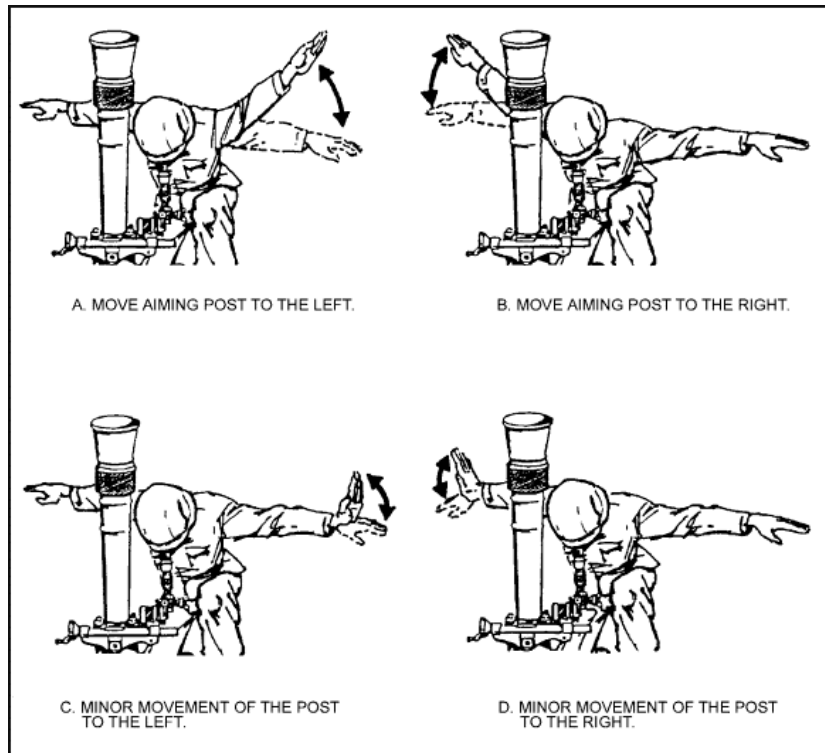

Figure 2-32. Arm-and-hand signals used in placing out aiming posts.

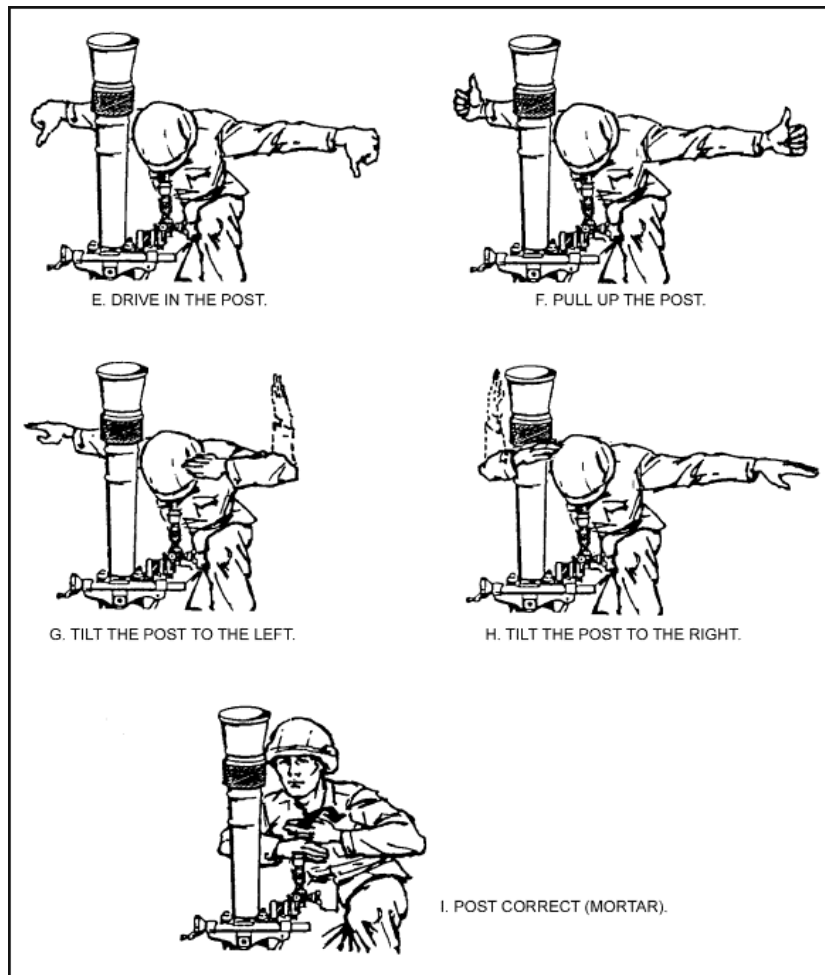

Figure 2-32. Arm-and-hand signals used in placing out aiming posts (continued).

a. Two more aiming posts must be placed out to prevent a sight block if the mortar is used in a 6400-mil capability. The section sergeant must then select an area to the rear of each mortar where aiming posts can be placed on a common deflection for all mortars. A common deflection of 0700 mils is preferred; however, any common deflection to the rear may be selected when obstacles,

traffic patterns, or terrain prevent use of 0700 mils. If the black deflection scale is moved, it can easily be re-indexed on the referred deflection.

b. After the section leader has laid the section for direction, he commands SECTION, REFER DEFLECTION (normally, TWO EIGHT ZERO ZERO), PLACE OUT AIMING POSTS. The initial steps are the same as those given above. The gunner refers the sight to the back deflection of the referred deflection and directs the ammunition bearer to place out two aiming posts 50 and 100 meters from the mortar position. If the gunner receives a deflection that would be obscured by the barrel, he indexes the referred back deflection, and lays in on the rear aiming post.

2-41. CORRECTION FOR DISPLACEMENT OF SIGHT

In laying the mortar for direction, the two aiming posts do not always appear as one when viewed through the sight(s). This separation is caused by one of two things: either a large deflection shift of the barrel or a rearward displacement of the baseplate assembly caused by the shock of firing.

a. When the aiming posts appear separated, the gunner cannot use either one as his aiming point. To lay the mortar correctly, he takes a compensated sight picture. Then, he traverses the mortar until the sight picture appears with the left edge of the far aiming post placed exactly midway between the left edge of the near aiming post and the vertical line of the sight. This corrects for the displacement. A memory trick for correcting displacement is: *Hey diddle diddle, far post in the middle.*

b. The gunner determines if the displacement is caused by traversing the mortar or by displacement of the baseplate assembly. To do so, he places the referred deflection on the sight and lays on the aiming posts. If both aiming posts appear as one, the separation is caused by traversing. Therefore, the gunner continues to lay the mortar as described and does not realign the aiming posts. When the posts appear separated, the separation is caused by displacement of the baseplate assembly. The gunner notifies his squad leader, who requests permission from the section/platoon leader to realign the aiming posts. (For more information, see Chapter 3, paragraph 3-14.)

Section VII. LOADING AND FIRING

Upon receiving a fire command from the section leader, the gunner repeats each element of it. He places the firing data on the sight and, assisted by the assistant gunner, lays the mortar. The first ammunition bearer repeats the charge element when announced by the gunner and prepares the round with that charge. (If a fuze setting is announced, the first ammunition bearer also repeats the setting and places it on the fuze.) He completes his preparation of the cartridge to include safety checks. The squad leader spot-checks the data on the sight and the lay of the mortar. He then commands FIRE.

2-42. FIRING THE MORTAR

The crew fires the mortar as follows:

- a. The gunner removes the sight, being careful not to disturb the lay of the mortar. He continues to remove the sight until the baseplate assembly is settled and there is no danger of the sight becoming damaged from the recoil of the mortar. The bipod assembly can slide up the barrel when the gunner fires the 81-mm mortar, M252 or the 120-mm mortar, M120. The gunner must not try to place the mortar back into position until the baseplate is settled.
- b. The first ammunition bearer passes a round to the assistant gunner. He holds the round with the palms of both hands up and near each end of the round so that the fuze is pointing in the general direction of the mortar.
- c. The assistant gunner takes the round from the first ammunition bearer with his right hand, palm up, and his left hand, palm down. He grasps the body of the round near the center, guides it into the barrel to a point beyond the narrow portion of the body of the shell, and releases the round. He cuts both hands sharply away and down along the barrel. At the same time, he pivots to the left and bends toward the first ammunition bearer, extending his hands to receive the next round. He is careful not to disturb the lay of the mortar as he loads the round (the round can bind as the base end enters the barrel). This can cause considerable dispersion in the target area and can create unsafe conditions due to erratic fire.

Note: See Chapter 6 for loading and firing the M329A2 round.

CAUTION

Do not load or fire the mortar while wearing gloves.

2-43. TARGET ENGAGEMENT

Target engagement is achieved through fire commands, which are the technical instructions issued to mortar crews. The basis for these commands is the data processed in the FDC. There are two types of commands: initial fire commands, issued to start a fire mission; and subsequent fire commands, issued to change firing data and to cease firing. The elements of both commands follow the same sequence. However, subsequent commands include only such elements that are changed, except for the elevation element, which is always announced. A correct fire command is brief and clear, and includes all the elements necessary for accomplishing the mission. The commands are sent to the platoon sergeant (section sergeant) by the best available means. To limit errors in transmission, the person receiving the commands at the mortar position repeats each element as it is received. The sequence for the transmission of fire commands is:

SEQUENCE	EXAMPLE
Mortars to follow	Section
Shell and fuze	HE quick
Mortars to fire	Number two
Method of fire	One round
Deflection	Deflection two eight hundred
Charge	Charge eight and four eighths
Time	
Elevation	Elevation nine hundred

Note: All fire commands follow this sequence. Elements not necessary for the proper conduct of fire are omitted.

2-44. EXECUTION OF FIRE COMMANDS

The various fire commands are explained herein.

a. **Mortars to follow.** This element serves two purposes: it alerts the section for a fire mission and it designates the mortars that are to follow the commands. The command for all mortars in the section to follow the fire command is SECTION. Commands for individual or pairs of mortars are given a NUMBER (ONE, TWO, and so forth).

b. **Shell and fuze.** This element alerts the ammunition bearers as to what type of ammunition and fuze action to prepare for firing--for example, HE QUICK; HE DELAY; HE PROXIMITY; and so forth.

c. **Mortar(s) to fire.** This element designates the specific mortar(s) to fire. If the mortars to fire are the same as the mortars to follow, this element is omitted. The command to fire an individual mortar or any combination of mortars is NUMBER(s) (ONE, THREE, and so forth).

d. **Method of fire.** In this element, the mortar(s) designated to fire in the preceding element is told how many rounds to fire, how to engage the target, and any special control desired. Also included are the number and type ammunition to be used in the fire-for-effect phase.

(1) *Volley fire.* A volley can be fired by one or more mortars. The command for volley fire is (so many) ROUNDS. Once all mortars are reported up, they fire on the platoon sergeant's (section sergeant's) command. If more than one round is being fired by each mortar, the squads fire the first round on command and the remaining as rapidly as possible consistent with accuracy and safety, and without regard to other mortars. If a specific time interval is desired, the command is (so many) ROUNDS AT (so many) SECONDS INTERVAL, or (so many) ROUNDS PER MINUTE. In this case, a single round for each mortar, at the time interval indicated, is fired at the platoon sergeant's (section sergeant's) command.

(2) *Section right (left).* This is a method of fire in which mortars are discharged from the right (left) one after the other, normally at 10-second intervals. The command for section fire from the right (left) flank at intervals of 10 seconds is SECTION RIGHT (LEFT), ONE ROUND. Once all mortars are reported up, the platoon sergeant (section sergeant) gives the command FIREX for example, SECTION RIGHT, ONE ROUND; the platoon sergeant (section sergeant) commands FIRE ONE; 10 seconds later FIRE TWO, and so forth.

(a) If the section is firing a section left, the fire begins with No. 3 and works to the right. The command LEFT (RIGHT) designates the flank from which the fire begins. The platoon sergeant (section sergeant) fires a section right (left) at 10-second intervals unless he is told differently by the FDC--for example, SECTION LEFT, ONE ROUND, TWENTY-SECOND INTERVALS.

(b) When it is desired to fire continuously at a target, the command is CONTINUOUS FIRE. When it is desired to maintain a smoke screen, it may be necessary to fire a series of sections right (left). In this case, the command is CONTINUOUS FIRE FROM THE RIGHT (LEFT). The platoon sergeant (section sergeant) then fires the designated mortars consecutively at 10-second intervals unless a different time interval is specified in the command.

(c) Changes in firing data (deflections and elevations) are applied to the mortars in turns of traverse or elevation so as not to stop or break the continuity of fire--for example, NUMBER ONE, RIGHT THREE TURNS; NUMBER TWO, UP ONE TURN. When continuous fire is given in the fire command, the platoon sergeant (section sergeant) continues to fire the section until the FDC changes the method of fire or until the command END OF MISSION is given.

(3) *Traversing fire.* In traversing fire, rounds are fired with a designated number of turns of traverse between each round. The command for traversing fire is (so many) ROUNDS, TRAVERSE RIGHT (LEFT) (so many) TURNS. At the platoon sergeant's (section sergeant's) command FIRE, all mortars fire one round, traverse the specified number of turns, fire another round, and continue this procedure until the number of rounds specified in the command have been fired.

(4) *Searching fire.* Searching fire is fired the same as volley fire except that each round normally has a different range. No specific order is followed in firing the rounds. For example, the assistant gunner does not start at the shortest range and progress to the highest charge or vice versa, unless instructed to do so. Firing the rounds in a definite sequence (high to low or low to high) establishes a pattern of fire that can be detected by the enemy.

(5) *At my command.* If the FDC wants to control the fire, the command AT MY COMMAND is placed in the method of fire element of the fire command. Once all mortars are reported up, the platoon sergeant (section sergeant) reports to the FDC: SECTION READY. The FDC then gives the command FIRE.

(6) *Do not fire.* The FDC can command DO NOT FIRE immediately following the method of fire. DO NOT FIRE then becomes a part of the method of fire. This command is repeated by the platoon sergeant (section sergeant). As soon as the weapons are laid the platoon sergeant (section sergeant) reports to FDC that the section is laid. The command for the section of fire is the command for a new method of fire not followed by DO NOT FIRE.

(7) *Deflection.* This element gives the exact deflection setting to be placed on the mortar sight. It is always announced in four digits, and the word DEFLECTION always precedes the sight setting--for example, DEFLECTION, TWO EIGHT FOUR SEVEN (2847). When the mortars are to be fired with different deflections, the number of the mortar is given and then the deflection for that mortar--for example, NUMBER THREE, DEFLECTION TWO FOUR ZERO ONE (2401).

(8) *Charge.* This element gives the charge consistent with elevation and range as determined from the firing tables--for example, CHARGE FOUR (4). The word CHARGE always precedes the amount--for example, ONE ROUND, CHARGE FOUR (4).

(9) *Time.* The computer tells the ammunition bearer the exact time setting to place on the proximity, MTSQ, and the MT fuze. The command for

time setting is TIME (so much)-- for example, TIME TWO SEVEN. The command for a change in time setting is a new command for time.

(10) *Elevation*. This element serves two purposes: first, it gives the exact elevation setting that is to be placed on the mortar sight; second, it serves as the command to fire, if no restrictions are placed on method of fire. When no restrictions are announced in the method of fire, the section, when laid, fires at the platoon sergeant's (section sergeant's) command FIRE. The platoon sergeant (section sergeant) may allow the mortar(s) to fire when ready. The elevation element is always given in a fire command. It is announced as, "Elevation (so many mils)."

2-45. ARM-AND-HAND SIGNALS

When giving the commands FIRE or CEASE FIRING, the section leader or squad leader uses both arm-and-hand signals and voice commands (Figure 2-33).

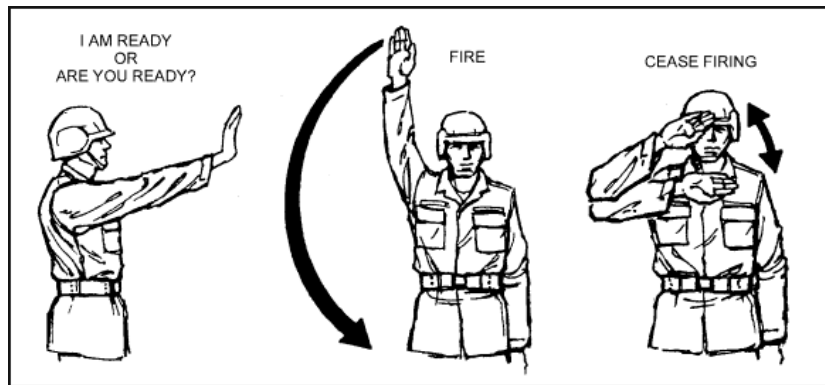

Figure 2-33. Arm-and-hand-signals for ready, fire, and cease firing.

- a. **Ready.** The signal for "I am ready" or "Are you ready?" is to extend the arm toward the person being signaled. Then, the arm is raised slightly above the horizontal, palm outward.
- b. **Fire.** The signal to start fire is to drop the right arm sharply from a vertical position to the side. When the section leader desires to fire a single mortar, he points with his arm extended at the mortar to be fired, then drops his arm sharply to his side.
- c. **Cease Firing.** The signal for cease firing is to raise the hand in front of the forehead, palm to the front, and to move the hand and forearm up and down several times in front of the face.

2-46. SUBSEQUENT FIRE COMMANDS

Only the elements that change from the previous fire command are announced in this command. However, the elevation element (command to fire) is always announced in the subsequent fire command.

- a. Changes in direction are given in total deflection to be placed on the sight--for example, DEFLECTION TWO EIGHT ONE TWO (2812).
- b. When a change is made in mortars to fire or in the method of fire, the subsequent command includes one or both of these elements and the elevation. When the elevation does not change, the command ELEVATION (so many mils) is given (same as that given in the previous command).
- c. To interrupt firing, CEASE FIRING or CHECK FIRE is commanded.
 - (1) CEASE FIRING indicates to the section the completion of a fire mission, but not necessarily the end of the alert. Firing is renewed by issuing a new initial fire command.
 - (2) CHECK FIRE indicates a temporary cessation of firing and allows firing to be resumed with the same data by the command RESUME FIRING or by a subsequent fire command.
- d. So that the mortar crews can relax between fire missions, the end of the alert is announced by the command END OF MISSION. All gunners then lay their mortars as directed by the FDC. Upon completion of a fire mission, all mortars normally lay on final protective fire data unless otherwise directed. It is the responsibility of the platoon sergeant (section sergeant) to ensure that the mortars are laid on final protective fire data and that the prescribed amount of ammunition for the final protective fire is prepared and on position.

2-47. REPEATING AND CORRECTING OF FIRE COMMANDS

If the platoon sergeant (section sergeant) or squad member fails to understand any elements of the fire command, he can request that element be repeated by starting--for example, "Say again deflection, elevation," and so forth. Misunderstanding is avoided when the repeated element is prefaced with "I say again deflection (repeats mils)."

- a. In an initial fire command, an incorrect element is corrected by stating, "Correction," and giving only the corrected element.
- b. In a subsequent command, an incorrect element is corrected by stating, "Correction," and then by repeating all of the subsequent commands. (The term "correction" cancels the entire command.)

2-48. REPORTING OF ERRORS IN FIRING

When any squad member discovers that an error has been made in firing, he immediately notifies his squad leader, who in turn notifies the FDC. Such errors include, but are not limited to, incorrect deflection or elevation settings, incorrect laying of the mortar, or ammunition improperly prepared for firing. Misfires are also reported this way. Errors should be promptly reported to the FDC to prevent loss of time in determining the cause and required corrective action.

2-49. NIGHT FIRING

When firing the mortar at night, the mission dictates whether noise and light discipline are to be sacrificed for speed. To counteract the loss of speed for night firing, the gunner must consider presetting both fuze and charge for illumination rounds with the presetting of charges for other rounds. The procedure for manipulating the mortar at night is the same as during daylight operations. To assist the gunner in these manipulations, the sight reticle is illuminated, and the aiming posts are provided with lights.

a. The instrument lights illuminate the reticle of the sights and make the vertical cross lines visible. The hand light on the flexible cord is used to illuminate the scales and bubbles.

b. An aiming post light is placed on each aiming post to enable the gunner to see the aiming posts. Aiming posts are placed out at night similar to the daylight procedure. The lights must be attached to the posts before they can be seen and positioned by the gunner. The gunner must issue commands such as NUMBER ONE, MOVE RIGHT, LEFT, HOLD, DRIVE IN, POST CORRECT. Tilt in the posts is corrected at daybreak. Some of the distance to the far post can be sacrificed if it cannot be easily seen at 100 meters. However, the near post should still be positioned about half the distance to the far post from the mortar. The far post light should be a different color from the one on the near post and be positioned so it appears slightly higher. Adjacent squads should alternate post lights to avoid laying on the wrong posts--for example, 1ST SQUAD, NEAR POST --GREEN LIGHT, FAR POST --RED LIGHT; 2D SQUAD, NEAR POST --RED LIGHT, FAR POST --GREEN LIGHT. (The M58 light is green and the M59 light is orange.)

c. The mortar is laid for deflection by placing the vertical cross line of the sight in the correct relation to the center of the lights attached to the aiming posts. The procedure for laying the mortar is the same as discussed in Section VI.

d. The night lights can be used to align the aiming posts without using voice commands.

(1) The gunner directs the ammunition bearer to place out the aiming posts. The ammunition bearer moves out 100 meters and turns on the night

light of the far aiming post. The gunner holds the instrument night light in his right (left) hand and, by moving the light to the right (left), directs the ammunition bearer to move to the right (left). To ensure that the ammunition bearer sees the light moving only in the desired direction, the gunner places his thumb over the light when returning it to the starting position. The gunner continues to direct the ammunition bearer to move the aiming post until it is properly aligned.

(2) The gunner moves the instrument light a shorter distance from the starting position when he desires the ammunition bearer to move the aiming post a short distance.

(3) The gunner holds the light over his head (starting position) and moves the light to waist level when he desires to have the ammunition bearer place the aiming post into the ground. In returning the instrument light to the starting position, the gunner covers the light with his thumb to ensure that the ammunition bearer sees the light move only in the desired direction.

(4) The gunner uses the same procedure described above when he wants the ammunition bearer to move the aiming post light to a position corresponding to the vertical hairline in the sight after the aiming post has been placed into the ground.

(5) The gunner reverses the procedure described above when he wants the ammunition bearer to take the aiming post out of the ground. The gunner places the uncovered light at waist level and moves it to a position directly above his head. He then directs alignment as required.

(6) When the gunner is satisfied with the alignment of the aiming posts, he signals the ammunition bearer to return to the mortar positions by making a circular motion with the instrument light.

Note: When the night light is used to signal, the gunner directs the light toward the ammunition bearer.

CHAPTER 3

60-mm MORTAR, M224

The 60-mm mortar, M224, reacts quickly to support infantrymen by engaging the target first. This allows infantrymen to confront the enemy while supporting the battle plan. The mortar can be fired accurately with or without a fire direction center.

Section I. SQUAD AND SECTION ORGANIZATION AND DUTIES

This section discusses the organization and duties of the 60-mm mortar squad and section.

3-1. ORGANIZATION

If the mortar section is to operate quickly and effectively in accomplishing its mission, mortar squad members must be proficient in individually assigned duties. Correctly applying and performing these duties enables the mortar section to perform as an effective fighting team. The section leader commands the section and supervises the training of the elements. He uses the chain of command to assist him in effecting his command and supervising duties.

3-2. DUTIES

The mortar squad consists of three soldiers. Each squad member is cross-trained to perform all duties involved in firing the mortar. The positions and principal duties are as follows:

- a. The *squad leader* is in position to best control the mortar squad. He is positioned to the right of the mortar, facing the barrel. He is also the FDC.
- b. The *gunner* is on the left side of the mortar where he can manipulate the sight, elevating gear handle, and traversing assembly wheel. He places firing data on the sight and lays the mortar for deflection and elevation. Assisted by the squad leader (or ammunition bearer), he makes large deflection shifts by shifting the bipod assembly.
- c. The *ammunition bearer* is to the right rear of the mortar. He prepares the ammunition and assists the gunner in shifting and loading the mortar. He swabs the barrel every 10 rounds or after each end of mission.

Section II. COMPONENTS

The 60-mm mortar, M224, can be fired in the conventional mode or handheld mode (Figure 3-1). The mortar is a muzzle-loaded, smooth-bore, high-angle-of-fire weapon. It can be drop-fired or trigger-fired and has five major components.

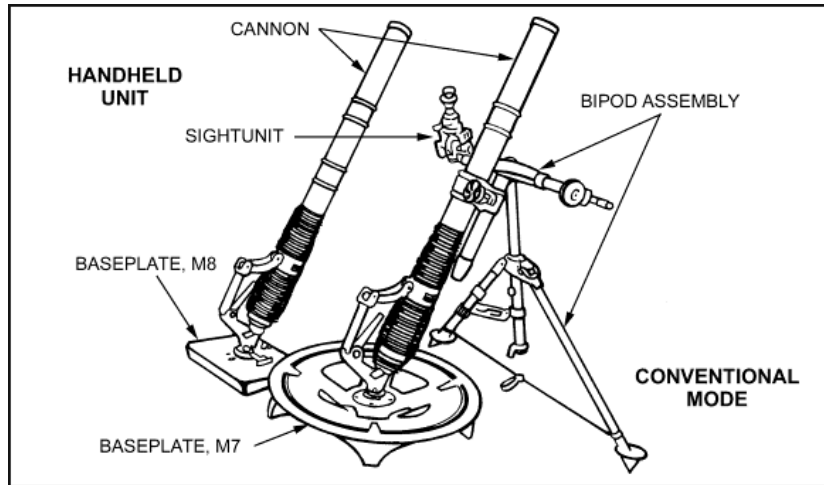

Figure 3-1. The 60-mm mortar, M224, (handheld mode and conventional mode).

3-3. TABULATED DATA

The tabulated data of the 60-mm mortar are as shown in Table 3-1.

CONVENTIONAL MODE	HANDHELD MODE
----------------------	------------------

WEIGHTS

Complete mortar	46.5 pounds	18.0 pounds
Cannon, M225	18.0 pounds	14.4 pounds
Bipod Assembly, M170	15.2 pounds (traverse, 250 miles)	
	2.5 pounds	
Sightunit, M64A1	(1.5 candlepower; 17.5 degrees field of view)	
	14.4 pounds	
Baseplate, M7	3.6 pounds	
Baseplate, M8		

RANGE

Cannon, M225	70 meters	75 meters
Minimum	3,490 meters	1,340 meters
Maximum	70 to 3,490 meters	70 to 1,340 meters
HE (M888)	70 to 3,490 meters	70 to 1,340 meters
HE (M720)	44 to 1,930 meters	50 to 1,300 meters (charge 3)
HE (M49A4)	33 to 1,630 meters	3)
WP (M302A1)	725 to 951 meters	45 to 1,200 meters (charge 3)
Illum (M83A3)	56 to 538 meters	3)
TP (M766) SRTR		725 to 750 meters (charge 2)

RATE OF FIRE

<i>Maximum</i>	30 rounds for first 4 minutes	
M720/M888		
M49A4	30 rounds for 1 minute; 18 rounds for next 4 minutes	No limit at charges 0 and 1
<i>Sustained</i>		
M720/M888	20 rounds per minute indefinitely	
M49A4	8 rounds per minute indefinitely	

TYPE OF FIRE	Drop-fire	Drop-fire (charges 0 and 1 only) Trigger-fire*
---------------------	-----------	--

CARRYING OPTIONS	One-man carry	One-man carry
-------------------------	---------------	---------------

Two-man carry
Three-man carry

*Do not trigger-fire above charge 1.

Table 3-1. Tabulated data.

3-4. CANNON ASSEMBLY, M225

The cannon assembly (Figure 3-2) has one end closed by a base cap. The base cap end of the cannon has cooling fins on the outside, which reduce heat generated during firing. Attached to the base cap end is a combination carrying handle and firing mechanism. The carrying handle has a trigger, firing selector, range indicator, and auxiliary carrying handle. On the outside of the barrel is an upper and a lower firing saddle. The lower saddle is used when firing at elevations of 1100 to 1511 mils; the upper saddle is used when firing at elevations of 0800 to 1100 mils.

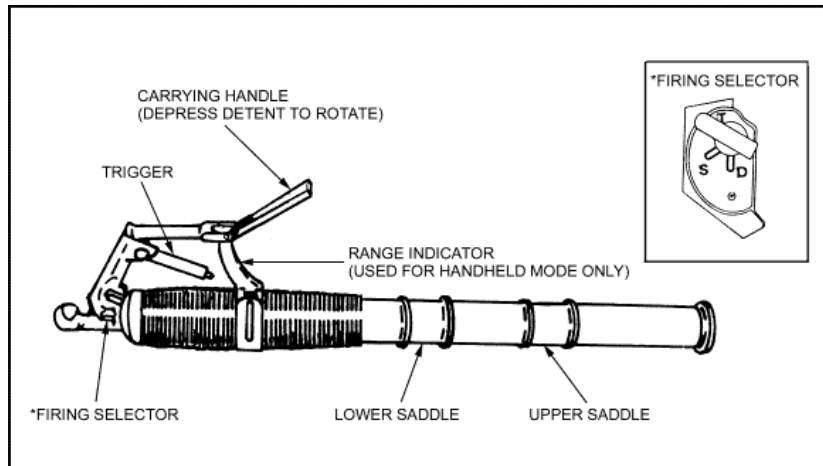

Figure 3-2. Cannon assembly, M225.

Note: When the bipod is positioned in the upper saddle, one turn of the traversing handwheel will move the barrel 10 mils. When the bipod is positioned in the lower saddle, one turn of the traversing handwheel will move the barrel 15 mils.

3-5. BASEPLATE, M7

The baseplate, M7, (Figure 3-3) is a one-piece, circular, aluminum-forging base. It has a ball socket with a rotating locking cap and a stationary retaining ring held in place by four screws and lock washers. The locking cap rotates 6400 mils, giving the mortar full-circle firing capability. The underside of the baseplate has four spades to stabilize the mortar during firing.

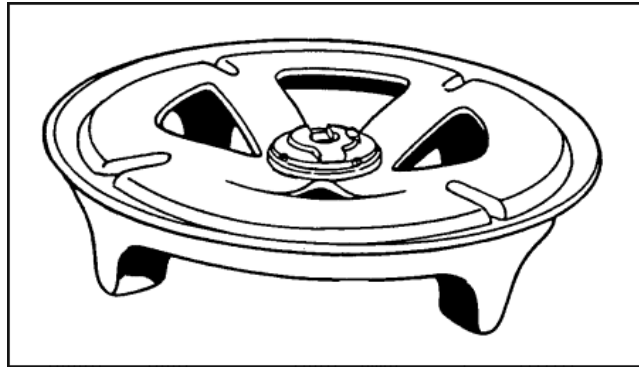

Figure 3-3. Baseplate, M7.

3-6. BASEPLATE, M8

The baseplate, M8, (Figure 3-4) is a one-piece, rectangular, aluminum-forging base. It should be used when the mortar is fired in the handheld mode. The baseplate allows the mortar to be fired 0800 mils left and 0800 mils right of the center of sector for a total sector coverage of 1600 mils. It has a socket in which the barrel can be locked to the baseplate by securing the locking arm. The underside of the baseplate has four spades to strengthen and stabilize the mortar during firing. Two spring-loaded plungers lock the baseplate to the barrel in its carry position.

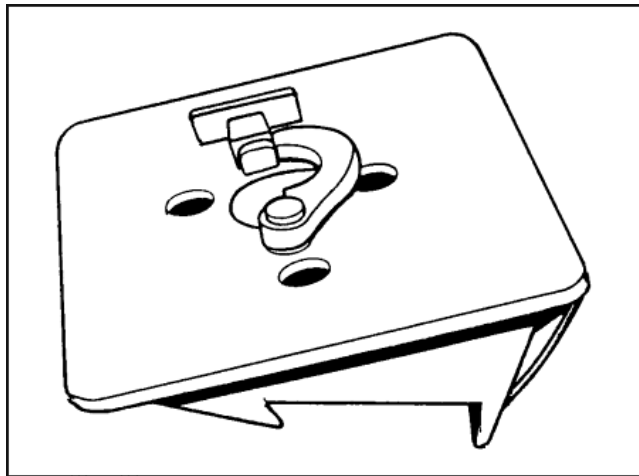

Figure 3-4. Baseplate, M8.

3-7. BIPOD ASSEMBLY, M170

The bipod assembly (Figure 3-5) can be assembled to the barrel either before or after assembly of the barrel to the baseplate. It consists of seven subassemblies.

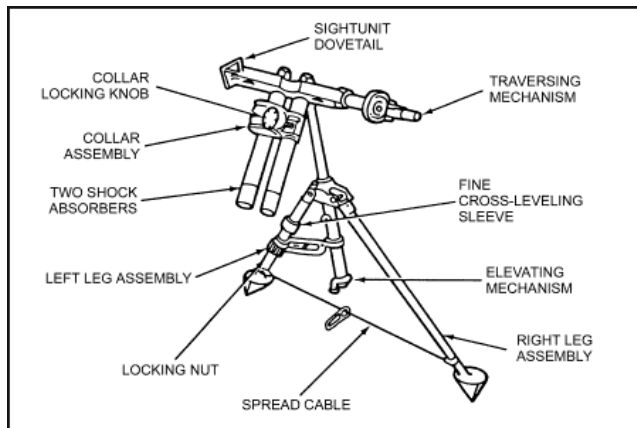

Figure 3-5. Bipod assembly, M170.

a. **Collar Assembly.** The collar assembly, with an upper and lower half, is hinged on the left and secured by a locking knob on the right. The collar fastens in one of the two firing saddles (depending on the elevation being fired), securing the bipod to the barrel.

b. **Shock Absorbers.** Two shock absorbers located on the underside of the collar assembly protect the bipod and sight from the shock of recoil during firing.

c. **Traversing Mechanism.** The traversing mechanism moves the collar assembly left or right when the traversing hand crank is pulled out and turned. The hand crank is turned clockwise to move the barrel to the right, and counterclockwise to move the barrel to the left. The left side of the traversing mechanism has a dovetail slot to attach the sight to the bipod.

d. **Elevating Mechanism.** The elevating mechanism is used to elevate or depress the barrel by turning the hand crank at the base of the elevation guide tube. This assembly consists of an elevating spindle, screw, hand crank, and housing (elevation guide tube). The housing has a latch to secure the collar and shock absorbers to the housing for carrying. The hand crank is turned clockwise to depress, and counterclockwise to elevate.

e. **Right Leg Assembly.** The right leg assembly has no moving parts. It consists of a foot, tubular steel leg, and hinge attached to the elevating mechanism housing.

f. **Left Leg Assembly.** The left leg assembly consists of a foot, tubular steel leg, hinge attached to the elevating mechanism housing, locking nut, and fine cross-leveling sleeve.

(1) The locking sleeve is near the spiked foot. It is used to lock the elevation housing in place.

(2) The fine cross-leveling nut above the locking sleeve is used for fine leveling.

g. **Spread Cable.** The spread cable is a plastic-coated steel cable attached to the bipod legs, which controls the spread of the two tubular steel legs. A snap hook is fixed to the cable to secure the bipod legs when they are collapsed for carrying.

Section III. OPERATION

Safe operation of the 60-mm mortar requires that training include drill practice on tasks for safe manipulation and effective employment. Crew training achieves the speed, precision, and teamwork needed to deliver responsive and effective fire on target.

3-8. PREMOUNT CHECKS

Before the mortar is mounted, the squad must perform premount checks. Each squad member should be capable of performing all the premount checks.

- a. The gunner performs the premount checks on the mount so that--
 - The spreader cable is fixed to both legs and taut.
 - The clearance on the left leg above the adjusting nut is two fingers in width.
 - The locking sleeve is neither too loose nor too tight.
 - The traversing bearing is centered.
- b. The squad leader performs the premount checks on the barrel so that--
 - The barrel is clean both inside and outside.
 - The firing pin is visible.
 - The spherical projection is clean, and the firing pin is firmly seated.
 - The selector switch is on drop-fire mode.
- c. The ammunition bearer is responsible for the premount checks on the baseplate ensuring that--
 - The rotatable socket cap moves freely and has a light coat of oil.
 - The ribs and braces are checked for breaks and dents, and the inner ring is secured to the outer ring.
- d. When all pieces of equipment are checked, the gunner notifies the section leader by announcing, "All correct."

3-9. MOUNTING OF THE MORTAR

The squad leader picks up and places the sight case and two aiming posts at the exact position where the mortar is to be mounted.

- a. The ammunition bearer places the outer edge of the baseplate against the baseplate stake. He aligns the left edge of the cutout portion of the baseplate with the right edge of the baseplate stake. He then rotates the socket cap so that the open end points in the direction of fire.
- b. The gunner picks up the bipod with his left hand on the traversing hand crank and his right hand on the dovetail slot. He moves forward of the baseplate about 12 to 15 inches and faces the baseplate on line with the left edge (gunner's viewpoint) of the baseplate. Dropping down on one knee in front of the bipod, the gunner supports the bipod with his left hand on the gear case. He then detaches the hook and unwraps the cable assembly. The gunner places his left hand on the midsection of the traversing slide and his right hand on the mechanical leg, and he extends the bipod legs the length of the cable assembly. He then aligns the center

of the bipod assembly with the center of the baseplate. He ensures that the elevation guide barrel is vertical and the locking nut is hand tight. The gunner moves to the mechanical leg side and supports the bipod with his left hand on the shock absorber. He unscrews the collar locking knob to open the collar.

c. The ammunition bearer picks up the barrel and inserts the spherical projection of the base plug into the socket. He rotates the barrel 90 degrees to lock it to the baseplate. If performed properly, the carrying handle is on the upper side of the barrel, facing skyward.

d. The gunner pushes down on the shock absorber and raises the collar assembly. The ammunition bearer lowers the barrel and places the lower saddle on the lower part of the collar. The gunner closes the upper part of the collar over the barrel. He replaces the locking knob to its original position and makes it hand tight. The ammunition bearer cranks the elevation hand crank up 15 to 17 turns.

e. The gunner takes the sight out of the case and sets a deflection of 3200 mils and an elevation of 1100 mils. He mounts the sight to the mortar by pushing the lock latch on the sight inward. He slides the dovetail on the sight into the dovetail slot on the bipod until firmly seated. The gunner releases the latch. He should tap up on the bottom of the sight to ensure proper seating. He then levels the mortar first for elevation 1100 mils, and then cross-levels. The gunner announces, "(gun number) up," to his squad leader.

3-10. SAFETY CHECKS BEFORE FIRING

Safety checks are performed by the entire squad.

a. The gunner ensures that--

(1) There is mask and overhead clearance.

(a) Since the mortar is normally mounted in defilade, there could be a mask such as a hill, trees, buildings, or a rise in the ground. Roofs or overhanging tree branches can cause overhead interference. The gunner must be sure the round does not strike any obstruction.

(b) When selecting the exact mortar position, the squad leader checks quickly for mask and overhead clearance. After the mortar is mounted, the gunner checks it thoroughly. He determines mask and overhead clearance by sighting along the top of the barrel with his eye placed near the base plug. If the line of sight clears the mask, it is safe to fire. If not, he may still fire at the desired range by selecting a charge zone having a higher elevation for that particular range. When firing under the control of an FDC, the

gunner reports to the FDC that mask clearance cannot be obtained at a certain elevation.

(c) Firing is slowed if mask clearance is checked before each firing. Therefore, if the mask is not regular throughout the sector of fire, the minimum mask clearance is determined to eliminate the need for checking on each mission. To do this, the gunner depresses the barrel until the top of the mask is sighted. He then levels the elevation bubble and reads the setting on the elevation scale and elevation micrometer. That setting is the minimum mask clearance. The gunner notifies the squad leader of the minimum mask clearance elevation. Any target that requires that elevation or lower cannot be engaged from that position.

(d) Placing the mortar in position at night does not relieve the gunner of the responsibility for checking for mask and overhead clearance.

(2) The barrel is locked to the baseplate and the open end of the socket cap points in the direction of fire. The bipod should be connected to either the upper or lower saddle of the barrel.

(3) The barrel is locked on the collar by the locking knob.

(4) The locking nut is wrist tight.

(5) The cable is taut.

(6) The selector switch on the barrel is on drop-fire.

b. One crewman ensures that the bore is clean; he swabs the bore dry.

c. The second crewman ensures that each round is clean, safety pin is present, and ignition cartridge is in proper condition.

3-11. SMALL DEFLECTION AND ELEVATION CHANGES

With the mortar mounted and the sight installed, the gunner lays the sight on the two aiming posts (placed out 50 and 100 meters from the mortar) on a referred deflection of 2800 mils and an elevation of 1100 mils. The mortar is within two turns of center of traverse. The vertical cross line of the sight is on the left edge of the aiming post.

a. The gunner is given a deflection change in a fire command between 20 and 60 mils. The elevation change announced must be less than 90 mils and more than 35 mils.

b. As soon as the sight data are announced, the gunner places it on the sight, lays the mortar for elevation, and then traverses onto the aiming post by turning the traversing handwheel and the adjusting nut in the same direction. A one-quarter turn on the adjusting nut equals one turn of the traversing handwheel. When the gunner is satisfied with his sight picture he announces, "Up."

Note: The gunner repeats all elements given in the fire command.

c. After the gunner has announced "Up," the mortar should be checked by the squad leader to determine if the exercise was performed correctly.

3-12. LARGE DEFLECTION AND ELEVATION CHANGES

With the mortar mounted and the sight installed, the gunner lays the sight on the two aiming posts (placed out 50 and 100 meters from the mortar) on a referred deflection of 2800 mils and an elevation of 1100 mils.

a. The gunner is given a deflection and elevation change in a fire command causing the gunner to shift the mortar between 200 and 300 mils and an elevation change between 100 and 200 mils.

b. As soon as the sight data are announced, the gunner places it on the sight, elevates the mortar until the elevation bubble floats freely, and then centers the traversing bearing. If the elevation is between 1100 to 1511 mils, the cannon is mounted in the lower saddle. If the elevation is between 0800 to 1100 mils, the high saddle is used. If the saddle is changed, the squad leader helps the gunner.

c. The squad leader moves into position to the front of the bipod on either knee and grasps the bipod legs (palms out), lifting until the feet clear the ground enough to permit lateral movement. The gunner moves the mortar as the squad leader steadies it, attempting to horizontally maintain the traversing mechanism. To make the shift, the gunner places the fingers of his right hand in the muzzle (Figure 3-6) and his left hand on the left leg, and moves the mortar until the vertical line of the sight is aligned approximately on the aiming post. When the approximate alignment is completed, the gunner signals the squad leader to lower the bipod by pushing down on the mortar.

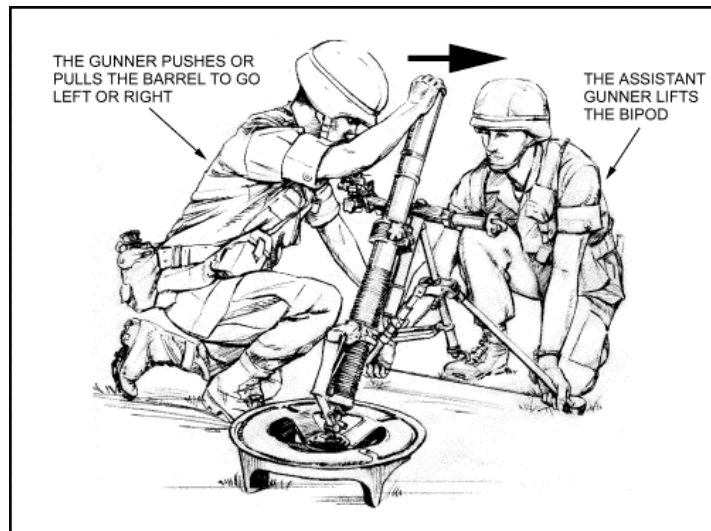

Figure 3-6. Large deflection and elevation changes.

d. The gunner levels the mortar for elevation, then cross-levels. He continues to traverse and cross-level until the correct sight picture is obtained. The mortar should be within two turns of center of traverse when the exercise is completed.

3-13. REFERRING OF THE SIGHT AND REALIGNMENT OF AIMING POSTS

Referring the sight and realigning aiming posts ensure that all mortars are set on the same data. The section leader, acting as the FDC, has one deflection instead of two.

- a. The sheaf is paralleled, and each mortar is laid on the correct data.
- b. The section leader, acting as the FDC, prepares an administrative announcement using the format for a fire command and the hit data of the base piece as follows:

"Section."
"Do not fire."
"Refer deflection one eight zero zero (1800)."
"Realign aiming posts."

- c. The gunners refer their sights to the announced deflection. Each gunner checks his sight picture. If he has an aligned sight picture, no further action is required.

d. In laying the mortar for direction, the two aiming posts do not always appear as one when viewed through the sight. This separation is caused by either a large deflection shift of the barrel or by a rearward displacement of the baseplate assembly caused by the shock of firing.

e. When the aiming posts appear separated, the gunner cannot correctly use either one of them as his aiming point. To lay the mortar correctly, he takes a compensated sight picture (Figure 3-7). He traverses the mortar until the sight picture appears with the left edge of the far aiming post, which is placed exactly midway between the left edge of the near aiming post and the vertical line of the sight. This corrects for the displacement.

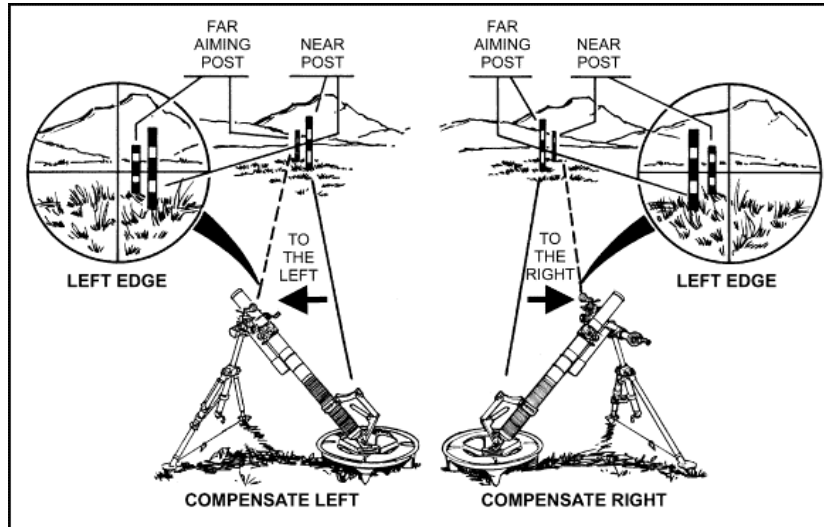

Figure 3-7. Compensated sight picture.

f. At the first lull in firing, the gunner must determine whether the displacement is caused by traversing the mortar or by displacement of the baseplate assembly. To do this, he places the referred initial deflection on the sight and lays on the aiming posts. If both aiming posts appear as one, the separation is caused by traversing. In this case, he continues to lay the mortar as described and does not realign the aiming posts. When the posts still appear separated, the separation is caused by displacement of the baseplate assembly. He notifies his squad leader, who in turn requests permission from the section leader to realign the aiming posts. To realign the aiming posts using the sightunit, the gunner--

- (1) Places on the sight the deflection originally used to place out the posts.

(2) Lays the mortar so that the vertical line of the sight is aligned on the left edge of the far aiming post.

(3) Without shifting the mortar, refers the sight until the vertical cross line falls on the left edge of the near aiming post. This actually measures the angle between the posts.

(4) With this last deflection set on the sight, re-lays the mortar until the vertical cross line is aligned on the far aiming post.

(5) Without shifting the mortar, refers the sight again to the original referred deflection used to place out the aiming posts. The line of sight, through the sight, is now parallel to the original line established by the aiming posts.

(6) Looking through the sight, directs the ammunition bearer to move the aiming posts so that they are realigned with the sight's vertical line. The posts are now realigned to correct the displacement.

Note: This procedure is used only when displacement is so great that it is difficult to obtain a compensated sight picture.

3-14. MALFUNCTIONS

Mortarmen must be aware of the following malfunctions.

a. **Misfire.** A misfire is a complete failure to fire. It can be caused by a faulty firing mechanism or faulty element in the propelling charge explosive train. A misfire cannot be immediately distinguished from a delay in functioning of the firing mechanism or from a hangfire; therefore, it must be handled with care. All firing malfunctions should be considered a misfire. Mechanical malfunctions can be caused by a faulty wiring pin or by rounds lodged in the barrel because of burrs, excess paint, oversized rounds, or foreign matter in the barrel. Procedures for removing a misfire are discussed in paragraph 3-15.

b. **Hangfire.** A hangfire is a delay in the functioning of a propelling charge explosive train at the time of firing. In most cases, the delay ranges from a split second to several minutes. Thus, a hangfire cannot be distinguished immediately from a misfire.

c. **Cookoff.** A cookoff is a functioning of one or more of the explosive components of a round chambered in a hot weapon, initiated by the heat of the weapon.

3-15. REMOVAL OF A MISFIRE

The procedures for removing a misfire are different for handheld and conventional modes. The propelling charge may not function for the following reasons:

- Defective ignition cartridge.
- Defective, damaged, or loose firing pin.
- Fouled firing pin or firing pin obstructed by extraneous material.
- Fouled bore.
- Excess oil or water in the bore.
- Misaligned stabilizing fin.
- Foreign matter or excess paint on round.
- Selector switch on SAFE or TRIGGER.

a. **Conventional Mode.**

(1) When a misfire occurs, any member of the squad immediately announces, "Misfire." The entire squad stays with the mortar. If it is obvious to the squad leader that the round has reached the bottom of the barrel and it has failed to ignite, the gunner places the selector switch on trigger fire and squeezes the trigger several times to try to clear the round.

WARNING

During peacetime live-fire training, the ammunition bearer moves at least 50 meters to the rear of the mortar.

- Notes:**
1. A faulty firing pin assembly on a 60-mm mortar, M224, requires that the firing pin be tightened upon completion of firing when frequent trigger firing using M720-, M721-, or M722-series ammunition. These type rounds usually fire when trigger fired.
 2. In case of a hangfire, kick the cannon several times to dislodge the round.

CAUTION

Trigger fire the M720-series rounds with charges 0 and 1 only. If an emergency requires trigger fire above charge 1, the baseplate must be well seated and extreme caution taken.

(2) If the round fails on trigger fire, the gunner places the selector switch back on drop fire. Staying clear of the muzzle at all times, the squad leader holds the bipod legs to prevent slippage. The gunner strikes the barrel sharply several times with the heel of his boot just above the handle assembly. If the round fails to dislodge after trigger firing and kicking, the gunner places the selector switch on SAFE.

WARNING

During peacetime live-fire training, the gunner and squad leader join the ammunition bearer and wait one minute (in case of a cookoff). After waiting one minute, the gunner returns to the mortar.

(3) The gunner checks for heat by starting from just below the muzzle and working down to the base with his fingertips. If the barrel is too hot to be handled, he cools it with water (or snow) and checks it one minute later. If no water (or snow) is available, the barrel is air cooled until it can be easily handled with bare hands.

Notes: 1. Liquids must never be poured into the barrel.

2. During peacetime live-fire training, the gunner signals the squad leader to come forward once the barrel is cool.

(4) The gunner locks the data down on the sight, then removes the sight and places it in a safe location. He then lowers the barrel to its minimum elevation and backs off one-quarter turn. **DO NOT MOVE THE BIPOD LEGS OR CHANGE THE FIRING SADDLE DURING THIS PROCEDURE.** The gunner unlocks the barrel from the baseplate by loosening the locking knob until the barrel can be rotated. He rotates the barrel 90 degrees in the socket cap so that the flats on the barrel are aligned with the flats of the socket cap. The squad leader places his left leg in front of the nonmechanical leg of the bipod to keep the bipod steady during the misfire removal. After placing his leg in this position, the squad leader places his left hand near the top of the barrel and his right hand on the underside, just below the muzzle. He prevents any part of his body from passing in front of the muzzle.

WARNING

Once the barrel reaches the horizontal, it must not be lowered back down until the round is extracted. If the round slips down the barrel before extraction, it could ignite, causing death or personal injury.

(5) The gunner continues to raise the barrel so that the base of the barrel is higher than the top. With the muzzle pointing toward the ground, the gunner shakes it slightly to help dislodge the round. As the round starts to clear the muzzle, the squad leader squeezes his thumbs against the body of

the round--not the fuze--and removes it. If the round fails to come out once the barrel is lifted, the barrel is lowered back to the horizontal. It is removed from the bipod assembly and placed in a designated dud pit. EOD personnel are notified for removal or disposal.

(6) Once the round has been removed, the squad leader gives the round to the ammunition bearer who inspects it. The ammunition bearer replaces any safety pins and inspects the primer of the ignition cartridge. If dented, the round should not be fired. If the primer has not been dented, the firing pin on the mortar should be checked for proper seating and tightened down if needed.

(7) While the round is being inspected, the gunner lowers the barrel back into the baseplate and remounts the sightunit to the bipod. The ammunition bearer then swabs the bore, and the gunner re-lays the mortar on the previous firing data.

Note: If the baseplate moved during the misfire procedure, the mortar must be reciprocally laid.

(8) If the primer on the round has not been dented, the gunner tries to fire the round again. If the same round misfires, he repeats the misfire procedures. If the primer has been dented, he notifies organizational maintenance IAW unit SOP.

b. Handheld Mode.

(1) When a misfire occurs, any member of the squad immediately announces, "Misfire." The entire crew stays with the mortar, and the gunner immediately pulls the trigger twice. If the round still fails to function, he announces, "Misfire." The gunner places the selector switch on SAFE and bounces the mortar from at least 6 inches off the ground to dislodge the round. (Disregard if the crew heard the round strike the bottom of the barrel.)

WARNING

During peacetime live -fire training, the gunner stays with the mortar and all other crew members move at least 50 meters behind the mortar.

Note: The gunner bounces the mortar only if the round is between the muzzle and firing pin.

(2) The gunner places the selector switch back on trigger fire and squeezes the trigger twice--the mortar should fire. If the round does not fire, he places the selector switch on SAFE and supports the mortar barrel with sand bags, logs, or empty ammunition boxes to keep the barrel upright and stable. He ensures the barrel is up and pointing downrange. The gunner checks for heat with his fingertips only, starting just below the muzzle and working down to the base.

WARNING

During peacetime live -fire training, the gunner joins the rest of the squad and waits one minute.

(3) If the barrel is hot, the gunner cools it with water (or snow) and then rechecks for heat. If there is no water (or snow), he lets the barrel air cool until it can be easily handled with bare hands.

Note: During peacetime live-fire training, the gunner signals the squad to come forward once the barrel is cool.

(4) Once the barrel is cool, the squad leader places his left hand (fingers and thumb extended and together) near the top of the barrel and his right hand on the underside just below the muzzle. In one smooth motion, the gunner lifts the base of the mortar with the M8 baseplate to the horizontal position. Once the barrel reaches the horizontal position, the squad leader extends the meaty portion of his thumbs over the end of the muzzle. The gunner continues to raise the base of the barrel past the horizontal. With the muzzle pointing downward, the gunner slightly shakes the barrel to help dislodge the round. As the round starts to clear the muzzle, the squad leader catches the round by squeezing his thumbs against the sides of the body--not the fuze--and removes it. The squad leader passes it to the ammunition bearer. If the fuze has safety pins (other than the M734), he tries to replace them.

(5) The ammunition bearer inspects the primer of the ignition cartridge. If dented, he does not try to fire the round again. If the pins cannot be replaced, the fuze may be armed. He lays the round in the designated dud pit and notifies EOD personnel.

(6) If the round does not come out after lifting the barrel up and shaking it, the gunner returns the barrel to the horizontal. The squad leader places the barrel in the designated dud pit and notifies EOD personnel.

WARNING

Once the barrel reaches the horizontal, it must not be lowered back down until the round is extracted. If the round slips down the barrel before extraction, it could ignite, causing death or personal injury.

(7) If the primer on the round has not been dented, the gunner lifts the base as high as possible. He shakes the barrel to dislodge any debris and swabs the bore. He tries to fire the round again. If two misfires occur in a row without the primer being dented, the gunner notifies organizational maintenance IAW unit SOP.

3-16. DISMOUNTING AND CARRYING OF THE MORTAR

To dismount and carry the mortar, the squad leader commands OUT OF ACTION.

a. **Dismounting.** The ammunition bearer retrieves the aiming posts. The gunner removes the sight, places an elevation of 0800 mils and a deflection of 3200 mils on the M64 sightunit, and places it in the case. Then he lowers the mortar to its minimum elevation and backs off one-quarter turn. He then centers the traversing mechanism and unlocks the collar with the collar locking knob.

(1) The squad leader grasps the base of the barrel and turns it 90 degrees (a one-quarter turn), until the spherical projection is in the unlocked position in the baseplate socket. He then lifts up on the base end of the barrel and removes it from the collar assembly. The ammunition bearer secures the baseplate.

(2) The gunner relocks the collar with the collar locking knob. He moves to the front of the bipod and faces it, kneels on his right knee with his left hand on the gear case, and loosens the locking nut. He tilts the bipod to his left and closes the bipod legs, placing the cable around the legs and rehooking the cable. He stands up, placing his right hand on the sight slot and his left hand on the traversing handwheel.

(3) On the command MARCH ORDER, squad members take the equipment distributed to them by the squad leader and move.

b. **Carrying.** The mortar can be carried by one or two men for short distances. When the sight is left mounted on the mortar, care must be taken to prevent damaging it.

(1) For a one-man carry, the mortar is in the firing position with the mount attached to the barrel at the lower saddle. The elevating mechanism is

fully depressed, and the bipod legs are together. The mount is folded back underneath the barrel until the elevating mechanism latches to the collar assembly. The cable is passed through one of the baseplate openings and wrapped around the barrel. The cable is attached to itself, using its snap hook. The carrying handle is used to carry the complete mortar.

(2) For a two-man carry, the M7 baseplate is one load, and the barrel/mount combination is the second load. The mount is attached to the barrel at the lower saddle, and the elevating mechanism is fully depressed. The bipod legs are together, and the bipod is folded up under the barrel until the elevating mechanism latches to the collar assembly. The cable is wrapped around the legs and barrel and hooked onto itself with its snap hook.

Note: The carrying position can be in the upper or lower saddle, depending on the mission or enemy situation.

(3) For the handheld mode, the M8 baseplate is left attached to the barrel. The baseplate is rotated 90 degrees to the right and rotated up until the two spring plungers on the front edge of the baseplate body latch onto the protrusion on the right side of the basecap. Then the auxiliary carrying handle is placed in the carrying position.

Section IV. AMMUNITION

This section implements STANAG 2321 and QSTAG 900 (Edition 1).

The type of ammunition selected to engage targets depends on the elevation.

3-17. CLASSIFICATION

All 60-mm mortar rounds, except training rounds, have three major components--a fuze, body, and tail fin with propulsion system assembly (Figure 3-8).

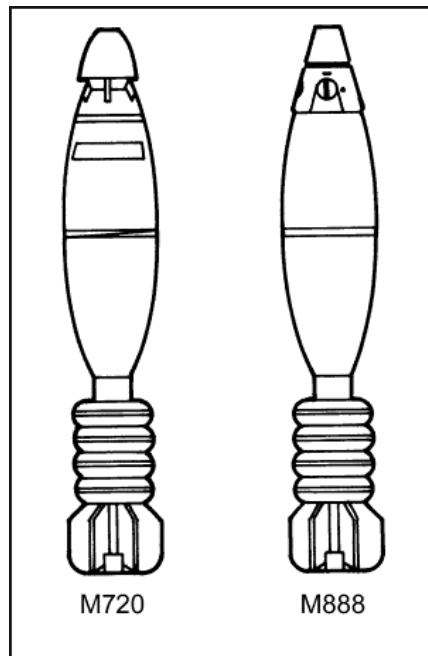

Figure 3-8. 60-mm mortar ammunition.

a. Based upon use, the principal classifications of training and service ammunition for the M224 mortar are as follows:

- (1) *High explosive (HE)*--Used against personnel and light materiel targets.
- (2) *White phosphorus (WP)*--Used as a screening, signaling, casualty-producing, or incendiary agent.
- (3) *Illumination (ILLUM)*--Used in night missions requiring illumination for assistance in observation.
- (4) *Training practice (TP)*--Used for training in limited areas.

b. The two service rounds specifically developed for the M224 mortar are the M720 and M888 HE rounds. The M720 round with multioption fuze (M734) has four settings--proximity, near-surface, impact, and 0.5-second delay. The M888 is

a standard point-detonating fuze (M935) with both impact and 0.5-second delay settings.

Note: A marking round, M722, and an illumination round, M721, have been type-classified.

c. The ammunition designed for the M2 and M19 mortars can be fired from the M224 mortar. When fired from the M224 mortar, greater ranges are achieved than those shown in the M2 and M19 firing tables. Standard A ammunition for the M2 and M19 mortars is standard B for the M224 mortar. No more than two charges are used when firing the M720 or M999 in either of the 60-mm mortars.

Note: Firing Table 60-P-1 has been published for all ammunition fired in the M224 mortar.

3-18. COLOR CODES

Mortar ammunition is painted and marked with a color code for quick, accurate identification. A color-code chart (Table 3-2) identifies rounds using the NATO color code and the US color code.

TYPE OF ROUND	NATO COLOR CODE			US COLOR CODE		
	ROUND	MARKINGS	BAND	ROUND	MARKINGS	BAND
HIGH EXPLOSIVE M720, M888, and M49A4 Causes troop casualties and damage to light material.	Olive Drab	Yellow Drab	NA	Olive	Yellow	Yellow
WHITE PHOSPHORUS M302A1 M302A2 To screen, signal, and act as an incendiary.	Light Green	Red	Yellow	Gray	Yellow	Yellow
ILLUMINATION M83A3 M721 To illuminate, signal, and mark.	White	Black	NA	NA	NA	NA
TRAINING PRACTICE M69TP M50A3 M766 (SRTR) For training and practice.	Blue Blue Blue	White White White	NA Brown NA	Blue Blue Blue	White White White	Brown

Table 3-2. Mortar ammunition color codes.

3-19. PREPARATION OF AMMUNITION

The ammunition bearer receives information in a fire command sent by the FDC and prepares the ammunition for firing. The number of rounds, type of round, fuze setting, and charge are all included in the fire command. To apply the data, the ammunition bearer selects the proper round, sets the fuze, and adjusts (removes or replaces) the charge on the quantity of rounds called for in the fire command. He also inspects each round for cleanliness and serviceability.

WARNING

For protection, a round(s) prepared but not fired should be returned to its container(s) *increment end first*. The pull wire on the M888 fuze must be replaced before returning it to its container.

The ammunition bearer should cut charges immediately in an FFE mission. In an adjust-fire mission, he should prepare the round and delay cutting the charges until FFE is entered. This is a precaution if the charge changes during adjustment.

3-20. TYPES OF FUZES

The two types of fuzes are the M734 multioption fuze and the M935 point-detonating fuze.

- a. **Multioption Fuze, M734.** This fuze for the M720 HE round can be set to function as proximity burst, near-surface burst, impact burst, or delay burst (Figure 3-9). Tools are not needed to set this fuze. The setting can be changed any number of times before firing without damaging the fuze. The fuze has no safety pins or wires to reduce preparation time. The round bursts at 1 to 4 meters (3 to 13 feet) above the target. If a round set for proximity fails to burst at the proximity distance above the target, it automatically bursts at 0 to 1 meter (0 to 3 feet) above the target. If a round set for near-surface burst (NSB) fails to burst at the near-surface distance above the target, it automatically bursts on impact. If a round set for impact fails to burst on impact, it automatically bursts 0.5 (1/2) second after impact (delay).

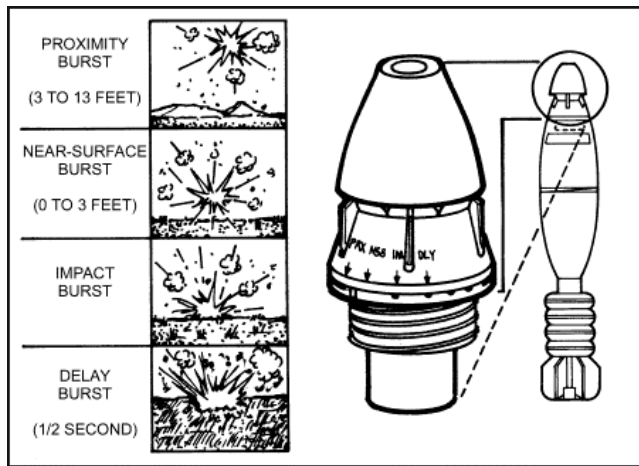

Figure 3-9. Multioption fuze, M734.

b. **Point-Detonating Fuze, M935.** This fuze for the M888 HE round can be set to function as superquick (SQ) or delay (D) (Figure 3-10). It has a standard pull-wire safety that is removed immediately before firing.

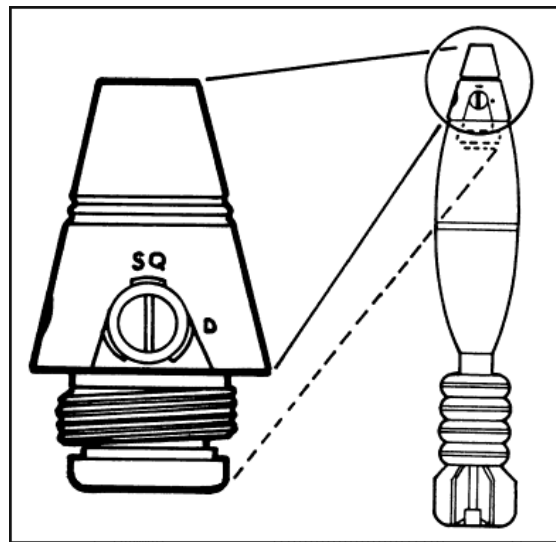

Figure 3-10. Point-detonating fuze, M935.

3-21. STANDARD B AMMUNITION

Standard B ammunition, designed for the M2 and M19 mortars, fits the bore (diameter) of the M224. Since the M224 has a longer barrel, firing tables developed for the standard B ammunition are not accurate when standard B ammunition is fired in the M224.

- a. The M720, M721, and M722 cartridges (designed specifically for M224 mortars) can be fired in the M19 mortar at reduced charges: maximum charge 2 for training and charge 3 in combat.
- b. The standard B rounds shown in Figure 3-11 are available for training with the M224. Ranges given are for general reference and could vary from those actually obtained. Never fire over charge 1 for the M720 or M888 cartridge when using the M224 in the handheld mode. Using standard B ammunition, HE can be fired up to charge 3 and WP/ILLUM can be fired up to charge 2.

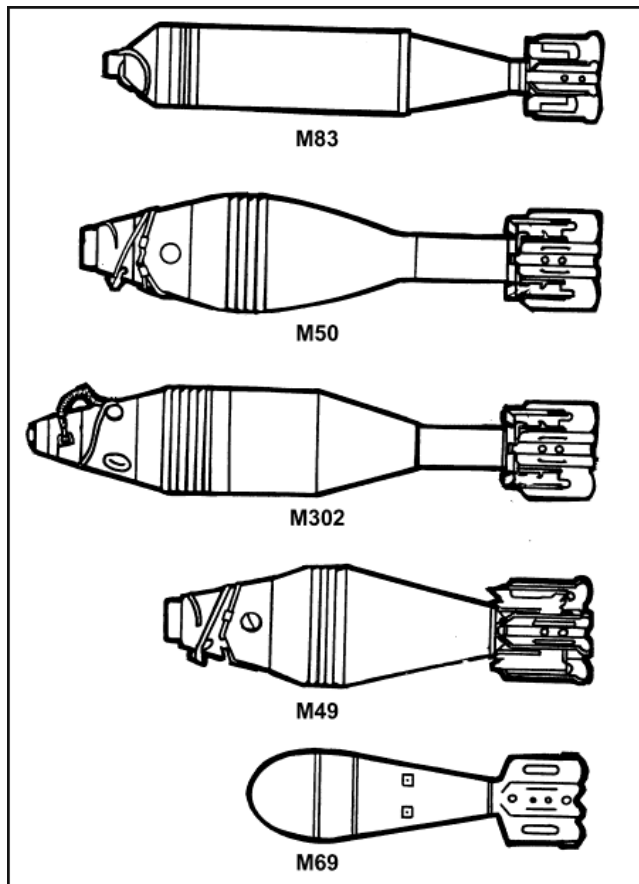

Figure 3-11. Standard B ammunition.

c. The M766 short-range training round (SRTR) cartridge (Figure 3-12) can be fired from the 60-mm mortar using standard sight and fire control equipment and firing table FT 60-P-1. A 60-mm subcaliber device can be inserted in the 4.2-inch mortar to fire the M766 (SRTR) for training 4.2-inch heavy mortar platoons.

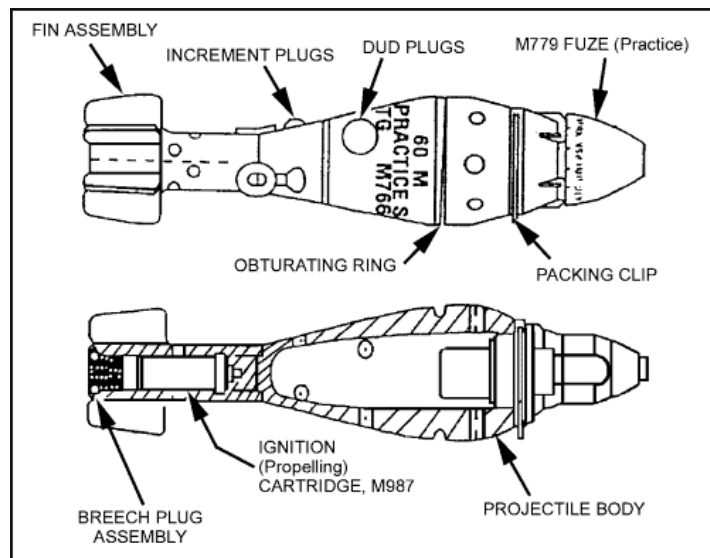

Figure 3-12. M766 (SRTR) cartridge.

(1) The M766 (SRTR) cartridge weighs 2.9 pounds and is 11 inches long. It has a maximum range of 538 meters and a minimum range of 56 meters. The cartridge is blue with white markings and one brown band.

(2) The M766 (SRTR) uses an M779 PD fuze, which produces a visible flash, a cloud of smoke, and an audible sound on impact for spotting purposes. The M779 has multioption type (PRX/NSB/IMP/DLY) dummy settings to simulate an M734 multioption fuze.

3-22. CARE AND HANDLING

Ammunition is manufactured and packed to withstand all conditions normally encountered in the field. However, moisture and high temperature can damage ammunition. Also, explosive elements in primers and fuzes are sensitive to strong shock and high temperature. Complete cartridges being fired should be handled with care.

WARNING

Do not try to disassemble any fuze.

a. The moisture-resistant seal of the shipping container should not be broken until the ammunition is to be used. When a large number of cartridges (15 or more for each squad) are prepared before a combat mission, the cartridges may be removed from the shipping container and the propellant increments adjusted. Then the fin assemblies should be reinserted into the container to protect the propelling charges.

b. Ammunition should be protected from mud, dirt, sand, water, and direct sunlight. Cartridges must be free of such foreign matter before firing. Ammunition that is wet or dirty should be wiped off at once.

c. Before firing, the gunner must remove the safety wire of the M888. Safety wires should be reinserted into all cartridges that have been prepared for firing but not used. Powder increments that have been removed should be replaced. Cartridges should be returned to their original packing and marked accordingly. (These cartridges should be used first in subsequent firings.)

WARNING

Duds are cartridges that have been fired but have not exploded. Duds are dangerous and should not be handled by anyone other than a member of the EOD team.

d. Ammunition should always be stored under cover. When this is not possible, it is raised at least 6 inches (15 centimeters) off the ground and covered with a double thickness of tarpaulin. Trenches are dug around the ammunition pile for drainage. WP cartridges must be stored with the fuze end up.

(1) In combat, store ammunition underground such as in bunkers.

(2) In the field, use waterproof bags, ponchos, ground cloths, and dunnage to prevent deterioration of ammunition. Ensure that ammunition does not become water-soaked.

(3) In arctic weather, store the ammunition in wooden boxes or crates. Place the boxes or crates on pallets and cover them with a double thickness of tarpaulin.

WARNING

Do not walk on, tumble, drag, throw, roll, or drop ammunition. Ensure that ammunition is kept in original container until ready for use. Do not combine WP and HE in

as outlined in TM 9-1300-206.

CHAPTER 4

81-mm MORTAR, M252

The 81-mm mortar, M252, delivers timely, accurate fires to meet the requirements of supported troops. This chapter discusses assigned personnel duties, crew drill, mechanical training, and characteristics of the mortar.

Section I. SQUAD AND SECTION ORGANIZATION AND DUTIES

Each member of the infantry mortar squad has principle duties and responsibilities. (See FM 7-90 for a discussion of the duties of the platoon headquarters.)

4-1. ORGANIZATION

If the mortar section is to operate quickly and effectively in accomplishing its mission, mortar squad members must be proficient in individually assigned duties. Correctly applying and performing these duties enables the mortar section to perform as an effective fighting team. The platoon leader commands the platoon and supervises the training of the elements. He uses the chain of command to assist him in effecting his command and supervising duties.

4-2. DUTIES

The mortar squad consists of five men (Figure 4-1). Their firing positions and principal duties are as follows:

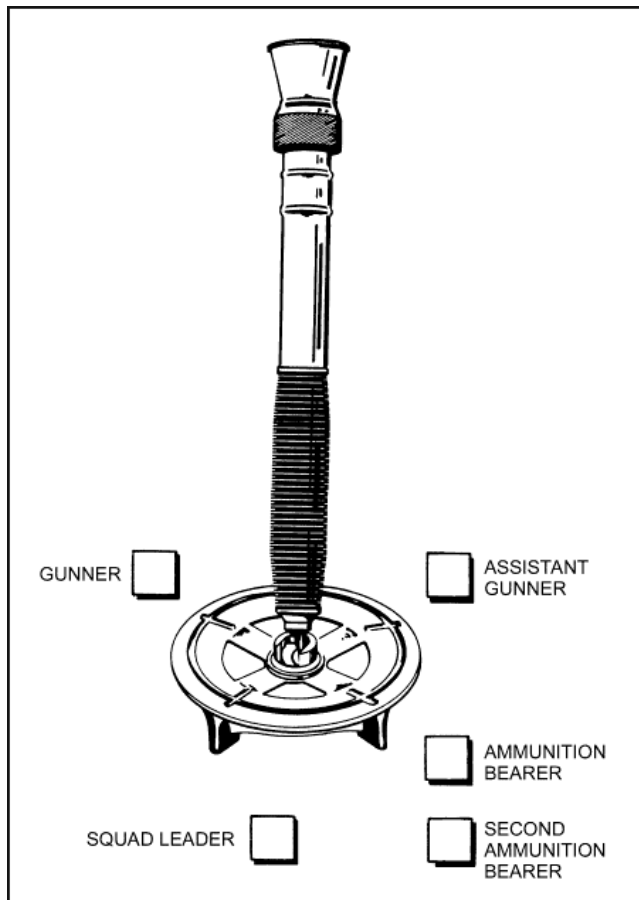

Figure 4-1. Position of squad members.

- a. The *squad leader* stands behind the mortar where he can command and control his squad. In addition to supervising the emplacement, laying, and firing of the mortar, he supervises all other squad activities.
- b. The *gunner* stands to the left side of the mortar where he can manipulate the sight, elevating handwheel, and traversing handwheel. He places firing data on the sight and lays the mortar for deflection and elevation. He makes large deflection shifts by shifting the bipod assembly and keeps the bubbles level during firing.

c. The *assistant gunner* stands to the right of the mortar, facing the barrel and ready to load. In addition to loading, he swabs the bore after 10 rounds have been fired or after each fire mission. He may assist the gunner in shifting the mortar when the gunner is making large deflection changes.

d. The *first ammunition bearer* stands to the right rear of the mortar. He has the duty of preparing the ammunition and passing it to the assistant gunner. He is also the squad driver.

e. The *second ammunition bearer* stands to the right rear of the mortar behind the ammunition bearer. He maintains the ammunition for firing and provides local security for the mortar position. He performs other duties as the squad leader directs.

Section II. COMPONENTS

The 81-mm mortar, M252, is a smooth-bore, muzzle-loaded, high-angle-of-fire weapon. The components of the mortar consist of a cannon, mount, and baseplate. This section discusses the characteristics and nomenclature of each component (Figure 4-2).

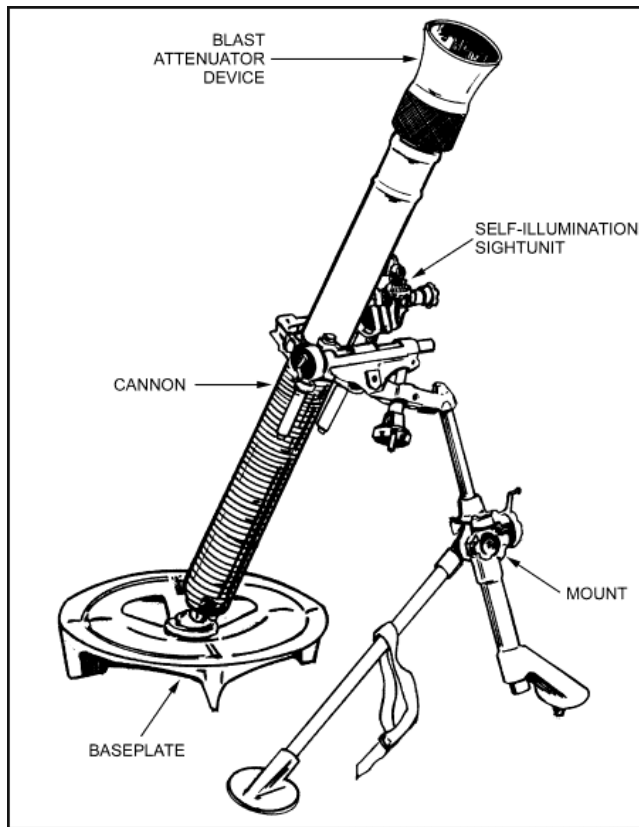

Figure 4-2. The 81-mm mortar, M252.

4-3. TABULATED DATA

The tabulated data of the 81-mm mortar, M252, are shown in Table 4-1.

Weights (pounds)	
System (including basic issue items)	121
Barrel (with blast attenuator device)	35
Mount	27
M3A1 Baseplate	29
M64A1 Sightunit	2.5

Ammunition	<u>HE</u>	<u>Smoke</u>	<u>Illum</u>	<u>Practice</u>
Ready to fire	9.4	10.6	9.1	9.4
In single container	12.0	13.8	12.4	12.5
In three-round pack	57.0	63.0	60.0	60.0
Elevation				
Elevation (approximate)				
For each turn of elevation drum (approximate)		800 to 1515 mils		
		10 mils		
Traverse				
Right or left from center (approximate)				
		100 mils (10 turns)		
Range				
Minimum to maximum		83 to 5,608 meters		
Rate of Fire				
Sustained				
Maximum		15 rounds per minute indefinitely		
		30 rounds per minute for 2 minutes		
HE Lethality (M821/M889)				
		30 percent greater than current US M374 series		
Smoke Screen (M819)				
(maximum range 4,875 meters)				
		90 to 150 by 30 to 40 meters		
		for 2 to 3 minutes		
Illumination (M853A1)				
(maximum range 5,050 meters)				
		600,000 candlepower for 1 minute		
HE Fuze Options				
		M821 w/multioption fuze M734		
		M889 w/point-detonating fuze M935		
Sight				
		M64A1, lightweight, self-Illuminating		

Table 4-1. Tabulated data.

4-4. CANNON ASSEMBLY, M253

The cannon assembly consists of the barrel that is sealed at the lower end with a removable breech plug, which houses a removable firing pin (Figure 4-3). At the muzzle end is a cone-shaped blast attenuator device (BAD) that is fitted to reduce noise. The BAD is removed only by qualified maintenance personnel.

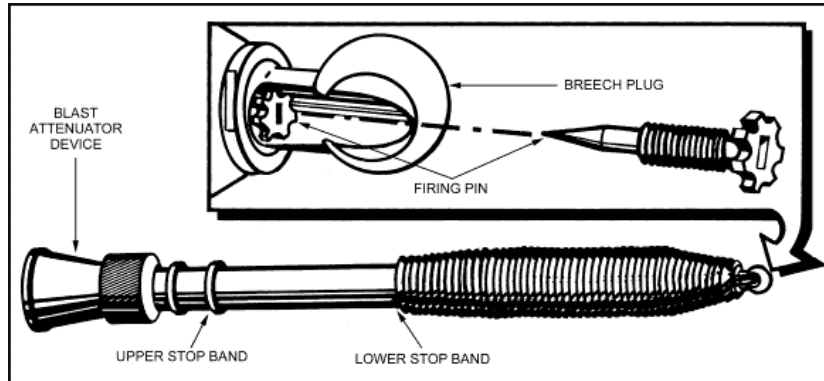

Figure 4-3. Cannon assembly, M253.

Note: The terms cannon and barrel are used interchangeably in this chapter.

4-5. MOUNT, M177

The mount consists of elevating and traversing mechanisms and a bipod (Figure 4-4).

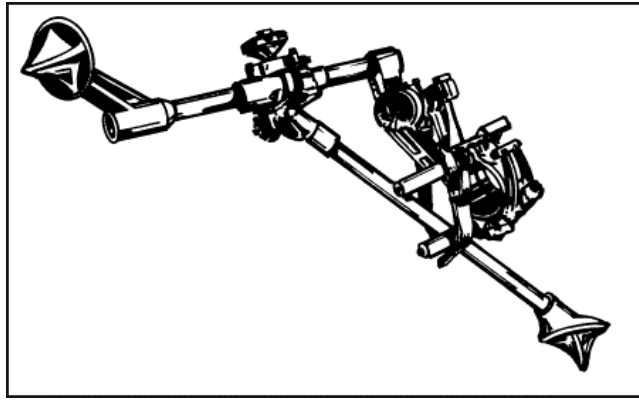

Figure 4-4. Mount, M177, in folded position.

- a. The bipod provides front support for the barrel and carries the gears necessary to lay the mortar. The barrel clamp, which consists of an upper and lower clamp, is situated at the top. The upper clamp is fitted with a locking arrangement that consists of a curved handle and a spring-loaded locking rod, which is ball-shaped at its lower end. The lower clamp is shaped and bored on each side to house the buffer cylinders. On its right side, the clamp is recessed to receive the ball end of the locking rod. A safety latch located at the side of the recess is used to secure the ball.
- b. The sight bracket is attached to the buffer carrier, which is fitted to the traversing screw assembly. Attached to the right of the screw is the traversing handwheel. The traversing screw assembly is fitted to the clamp assembly, which is pivoted in the center on an arm attached to the elevating leg. Attached to the arm is the cross-leveling mechanism, which is attached to the clamp assembly at its upper end.
- c. The elevating shaft is contained in the elevating leg; to the left of the elevating leg is the elevating handwheel. A plain leg is fitted to a stud on the elevating leg and is secured by a leg-locking handwheel. A spring-loaded locating catch is behind the elevating gear housing, which locates the plain leg in its supporting position for level ground. A securing strap is attached to the plain leg for securing the bipod in the folded position. Both legs are fitted with a disk-shaped foot with a spike beneath to prevent the mount from slipping.

4-6. BASEPLATE, M3A1

The baseplate (Figure 4-5) is of one-piece construction, and supports and aligns the mortar for firing. During firing, the breech plug on the barrel is sealed and locked to the rotatable socket in the baseplate.

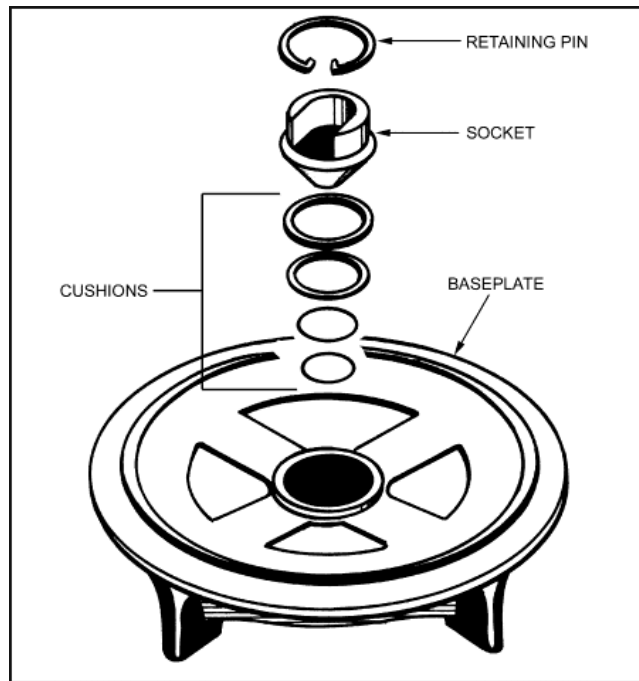

Figure 4-5. Baseplate, M3A1.

Section III. OPERATION

This section contains information on how to prepare the 81-mm mortar, M252, for firing, how to conduct safety checks, and, if a misfire should occur during firing, what actions the crew applies to remove the cartridge from the barrel.

4-7. PREMOUNT CHECKS

Before the mortar is mounted, the squad must perform premount checks. Each squad member should be able to perform all the following premount checks:

- a. The gunner checks the baseplate and ensures that--

- (1) The rotating socket is free to move in a complete circle.
- (2) The ribs and braces have no breaks, cracks, or dents.
- (3) The circlip is correctly located, securing the rotating socket to the baseplate.

b. The assistant gunner checks the bipod and ensures that--

- (1) The barrel clamps are clean and dry.
- (2) The barrel carrier is centered.
- (3) The securing strap is correctly located, securing the barrel clamps and buffers to the plain leg.
- (4) The leg-locking handwheel is hand tight.
- (5) Four inches of elevation shaft are exposed, and the shaft is not bent.

c. The first ammunition bearer checks the barrel and ensures that--

- (1) The barrel is clean and free from grease and oil both inside and out.
- (2) The breech plug is screwed tightly to the barrel.
- (3) The firing pin is secured correctly.
- (4) The blast attenuator device is secured correctly.

d. The squad leader supervises the squad drill and is responsible for supervising the laying out of the equipment as shown in Figure 4-6. The equipment is placed out the same as for the gunner's examination (Chapter 9).

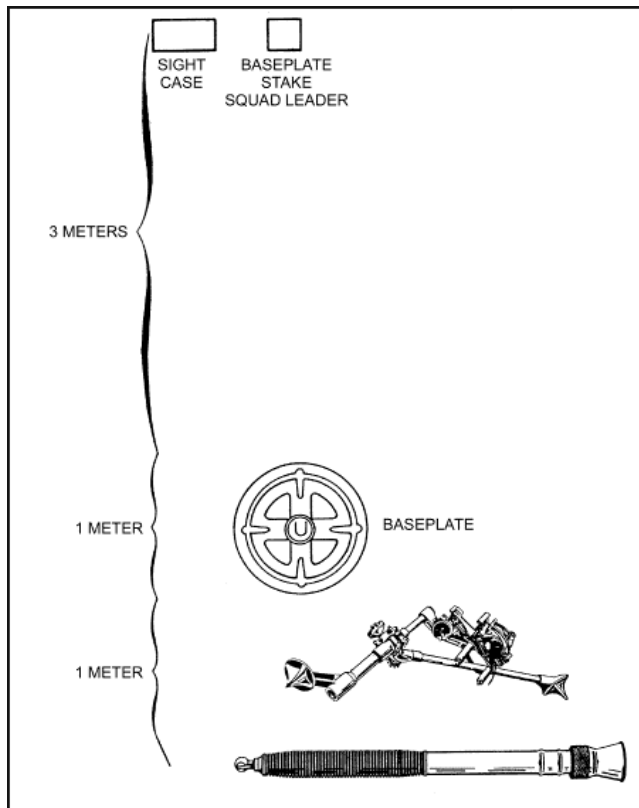

Figure 4-6. Layout of equipment.

4-8. MOUNTING OF THE MORTAR

The squad leader picks up the sight case and the two aiming posts, and moves to the exact position where the mortar is to be mounted. He places the sight case and aiming posts to the left front of the mortar position. The squad leader points to the exact spot where the mortar is to be mounted. He indicates the initial direction of fire by pointing in that direction and commands ACTION.

- a. The gunner places the outer edge of the baseplate against the baseplate stake so that the left edge of the cutaway portion of the baseplate is aligned with the right edge of the stake (Figure 4-7). He rotates the socket so that the open end is

pointing in the direction of fire. During training, the gunner may use the driving stake from the aiming post case.

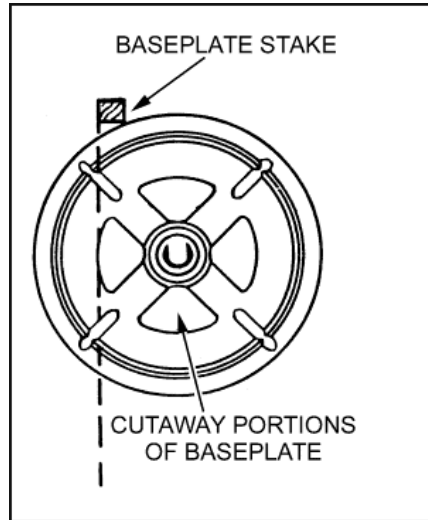

Figure 4-7. Baseplate placed against baseplate stake.

Note: The squad leader indicates the direction of fire when mounting.

b. When the baseplate is in position, the first ammunition bearer lowers the breech plug into the rotating socket and rotates the barrel a quarter of a turn to lock it. He ensures that the firing pin recess is facing upwards. He stands to the rear of the baseplate and supports the barrel until the bipod is fitted.

c. The assistant gunner lifts the bipod and stands it on its elevating leg so that the elevating handwheel is to the rear and the plain leg is to the front. He releases the securing strap, loosens the leg-locking handwheel, and lowers the plain leg until the locating catch engages in the recess. The leg-locking handwheel must then be tightened by hand, ensuring the teeth on either side are correctly meshed. The assistant gunner exposes 8 inches (200 millimeters) of elevation shaft, leaving the elevation handwheel unfolded. He opens the cross-level handwheel, traversing handwheel, and barrel clamp. The assistant gunner carries the bipod to the front of the barrel and places the bipod feet on the ground 12 to 15 inches in front of the baseplate and astride the line of fire. He positions the lower barrel clamp against the lower stop band on the barrel and secures the upper barrel clamp. He must ensure that the ball-shaped end of the locking rod is secured in its recess by the locking latch.

d. The gunner removes the sight from its case, mounts it on the mortar, and sets a deflection of 3200 mils and an elevation of 1100 mils. He levels all bubbles.

4-9. SAFETY CHECKS BEFORE FIRING

The following safety checks must be enforced before firing the mortar.

a. The gunner ensures that--

(1) Mask clearance and overhead clearance are sufficient.

(a) Since the mortar is normally mounted in defilade, there could be a mask such as a hill, tree, building, or rise in the ground. Overhead interference can be branches of trees or roofs of buildings. In any case, the gunner must ensure that the cartridge does not strike an obstacle.

(b) In selecting the exact mortar position, the leader looks quickly for mask clearance and overhead interference. After the mortar is mounted, the gunner makes a thorough check.

(c) The gunner determines mask and overhead clearance by sighting along the barrel with his eye near the breech plug. If the line of sight clears the mask, it is safe to fire. If not, he may still fire at the desired range by selecting a charge zone having a higher elevation. When firing under the control of an FDC, he reports to the FDC that mask clearance cannot be obtained at a certain elevation.

(d) Firing is slowed if mask clearance must be checked before each firing but this can be eliminated if minimum mask clearance is determined. This is accomplished by depressing the barrel until the top of the mask is clear. The gunner levels the elevation bubble by turning the elevation micrometer knob and reading the setting on the elevation scale and elevation micrometer--this setting is the minimum mask clearance. The squad leader notifies the FDC of the minimum mask clearance elevation. Any target that requires that elevation, or a lower one, cannot be engaged from that position.

(e) If the mask is not regular throughout the sector of fire, the gunner determines the minimum mask clearance as described above. Placing the mortar in position at night does not relieve the gunner of the responsibility of checking for mask clearance and overhead interference.

(2) The barrel is locked to the baseplate, and the open end of the socket points in the direction of fire.

(3) The firing pin recess faces upwards.

(4) The bipod locking latch is locked, securing the barrel clamps.

Note: See TM 9-1015-200-10 for more on loading and firing.

(5) The leg-locking handwheel is tight.

b. The assistant gunner cleans the bore and swabs it dry.

c. The first ammunition bearer ensures that each cartridge is clean, the safety pin is present, and the ignition cartridge is in good condition.

4-10. SMALL DEFLECTION AND ELEVATION CHANGES

With the mortar mounted and the sight installed, the gunner lays the sight on the two aiming posts (placed out 50 and 100 meters from the mortar) on a referred deflection of 2800 mils and an elevation of 1100 mils. The mortar is within two turns of center of traverse. The vertical cross line of the sight is on the left edge of the aiming point.

a. The gunner is given a deflection change in a fire command between 20 and 60 mils inclusive. The elevation change announced must be less than 90 mils and more than 35 mils.

b. As soon as the sight data are announced, the gunner places it on the sight, lays the mortar for elevation, and traverses onto the aiming post by turning the traversing handwheel and adjusting nut in the same direction. One-quarter turn on the adjusting nut equals one turn of the traversing handwheel. When the gunner is satisfied with his sight picture he announces, "Up."

Note: All elements given in the fire command are repeated by the squad.

c. After the gunner has announced, "Up," the squad leader should check the mortar to determine if the exercise was performed correctly.

4-11. LARGE DEFLECTION AND ELEVATION CHANGES

With the mortar mounted and the sight installed, the gunner lays the sight on the two aiming posts (placed out 50 and 100 meters from the mortar) on a referred deflection of 2800 mils and an elevation of 1100 mils.

- a. The gunner is given a deflection and elevation change in a fire command causing the gunner to shift the mortar between 200 and 300 mils for deflection and between 100 and 200 for elevation.
- b. As soon as the sight data are announced, the gunner places it on the sight. The gunner should expose 6 inches (150 millimeters) of elevation shaft and center the buffer carrier. This ensures a maximum traversing and elevating capability after making the movement.
- c. The assistant gunner moves into position to the front of the bipod on his right knee and grasps the bipod legs (palms up), lifting until they clear the ground enough to permit lateral movement. The gunner moves the mortar as the assistant gunner steadies it. The assistant gunner attempts to maintain the traversing mechanism on a horizontal plane. To make the shift, the gunner places the fingers of his right hand in the muzzle and his left hand on the left leg. He moves the mortar until the vertical line of the sight is aligned approximately on the aiming post. When the approximate alignment is completed, the gunner signals the assistant gunner to lower the bipod by pushing down on the mortar.
- d. The gunner rough levels the cross-level bubble by making the bubble bounce from one side to the other. He then checks the sight picture to ensure he is within 20 mils of a proper sight picture. If he is not within 20 mils, the gunner and assistant gunner must make another large shift before moving on.
- e. The gunner centers the elevation bubble. He lays for deflection, taking the proper sight picture. The mortar should be within two turns of center of traverse when the task is complete.
- f. The open end of the socket must continue to point in the direction of fire. Normally, it can be moved by hand, although this may be difficult to do if the mortar is moved through a large arc. If required, the gunner/assistant gunner lowers the barrel so that the breech plug engages with the open end of the socket, and he uses the barrel as a lever to move the socket.
- g. The barrel clamps can be moved along the barrel to counter large changes in elevation. This may preclude moving the bipod. It is especially useful if the baseplate sinks deep into the ground during prolonged firing. Upon completion of any bipod movement on the barrel, the gunner ensures that the firing pin recess is facing upward.
- h. Where the ground is uneven and there is no level surface for the bipod, the gunner can adjust the plain leg. While the assistant gunner supports the barrel, the gunner slackens the leg-locking handwheel, releases the locating catch, and positions the plain leg. The leg-locking handwheel must then be tightened, ensuring the teeth are correctly meshed.

4-12. REFERRING OF THE SIGHT AND REALIGNMENT OF AIMING POSTS USING M64 SIGHT

Referring and realigning aiming posts ensure that all mortars are set on the same data. The section leader, acting as FDC, has one deflection instead of two or more.

- a. The mortar is mounted and the sight is installed. The sight is laid on two aiming posts (placed out 50 and 100 meters from the mortar) on a referred deflection of 2800 mils and an elevation of 1100 mils. The mortar is within two turns of center of traverse. The gunner is given an administrative command to lay the mortar on a deflection of 2860 or 2740 mils. The mortar is then re-laid on the aiming posts using the traversing crank.
- b. The gunner is given a deflection change between 5 and 25 mils, either increasing or decreasing from the last stated deflection, and the command to refer and realign aiming posts.

EXAMPLE

REFER DEFLECTION TWO EIGHT SEVEN FIVE (2875), REALIGN AIMING POSTS.

- c. Upon receiving the command REFER, REALIGN AIMING POST, two actions take place at the same time in the mortar squad. The gunner places the announced deflection on the sight (without disturbing the lay of the weapon) and looks through the sightunit. At the same time, the first ammunition bearer moves out on the double to realign the aiming posts. He knocks down the near aiming post and proceeds to the far aiming post. Following the arm-and-hand signals of the gunner (who is looking through the sight unit), he moves the far aiming post so that the gunner obtains an aligned sight picture. The same procedure for aligning the far aiming post is used to align the near aiming post.

4-13. MALFUNCTIONS

See Chapter 3, paragraph 3-14 for a detailed discussion of malfunctions.

4-14. REMOVAL OF A MISFIRE

When a misfire occurs, any member of the squad immediately announces, "Misfire." The entire squad stays with the mortar. The gunner then kicks the barrel several times with his heel in an attempt to dislodge the round. If the round fires, the mortar is re-laid on the aiming point and firing is continued.

WARNING

During peacetime live -fire training, all personnel, except the gunner, move 50 meters or farther to the rear of the mortar.

a. If the round does not fire, the gunner tests the barrel for heat. If the barrel is cool enough to handle, the crew removes the round as described below. If the barrel is hot, the gunner may then apply water to the outside of the barrel until it is cool. If water is not available, the gunner must stand clear of the mortar until the barrel is cool.

WARNING

During peacetime live -fire training, if the round does not fire, the gunner joins the crew and waits one minute to avoid a possible personal injury due to a cookoff. After waiting one minute, the gunner returns to the mortar and tests the barrel for heat. When the barrel is cool enough to handle, the gunner signals for the rest of the crew to come forward.

b. After the barrel cools, the gunner removes the sight and firing pin. This ensures that the mortar does not fire should the round slip down the barrel during the subsequent drills. The gunner can depress the barrel, if necessary, to provide easier access to the firing pin. The gunner unlocks the barrel clamp and rotates the barrel, unlocking the breech plug from the rotating socket of the baseplate. Then he relocks the barrel clamp.

c. The gunner grasps both ends of the traverse screw assembly and supports the mortar during the subsequent drill. The assistant gunner places his right hand palm up (1 inch from the muzzle end) under the BAD and his left hand palm down (1 inch from the muzzle end) on top. He places his thumbs alongside the forefingers, being careful to keep both hands away from the muzzle. The first ammunition bearer puts both hands on the cooling fins under the barrel and slowly lifts the barrel until it is horizontal. He must not stand directly behind the mortar.

d. When the barrel reaches the horizontal position, and not before, the assistant gunner moves the thumb of each hand over the muzzle. When the fuze of the misfired round reaches the BAD, the assistant gunner stops the round with his thumbs (he does not touch the fuze) and carefully removes it from the barrel. The first ammunition bearer shakes the barrel to dislodge any remnants from the last round fired, and he lowers the barrel into the rotating socket of the baseplate.

e. The assistant gunner passes the round to the first ammunition bearer who inspects it for the cause of the misfire. If the primer of the ignition cartridge is dented, the first ammunition bearer attempts to replace the safety wire and places

the round in a marked, safe location for disposal by ordnance personnel. If the primer is not dented, the round may be used again. The firing pin must be replaced and the bore swabbed.

f. If the above procedure fails to remove the misfire, the barrel must be kept horizontal. Then it is removed from the bipod and laid horizontally on the ground at the dud pit until it can be turned over to ordnance personnel.

4-15. DISMOUNTING OF THE MORTAR

To dismount the mortar, the squad leader commands, OUT OF ACTION. At this command, the squad proceeds as follows:

- a. The gunner removes the sight and places it in the case with 3200 deflection and 0800 elevation indexed.
- b. The first ammunition bearer holds the barrel until the assistant gunner has removed the mount. The barrel is then rotated a quarter turn to unlock it from the socket, and it is placed in an area designated by the squad leader. The second ammunition bearer retrieves the aiming posts.
- c. The assistant gunner disengages the barrel clamps and moves the bipod from the immediate area of the mortar position. The barrel clamps are then closed. With the clamps facing away from him, the assistant gunner traverses the buffer carrier to the traversing handwheel and folds the handle. He exposes 1 inch (25 millimeters) of cross-level shaft and folds the handle. He exposes 4 inches (100 millimeters) of elevation shaft and folds the handle. Finally, the assistant gunner loosens the leg-locking handwheel, presses the spring-loaded locating catch, and raises the plain leg behind the buffer cylinders until it touches the traversing handwheel. He tightens the leg-locking handwheel (ensuring the teeth are correctly meshed) and fastens the securing strap over the arm and around the buffers.
- d. The gunner recovers the baseplate to the area designated by the squad leader.
- e. The squad leader picks up the aiming posts and sight. At the command, MARCH ORDER, the squad places the mortar, equipment, and ammunition in the squad vehicle and trailer.

Section IV. AMMUNITION

This section implements STANAG 2321 and QSTAG 900 (Edition 1).

The ammunition that can be fired by the 81-mm mortar, M252, is identified and described herein.

4-16. CLASSIFICATION

Ammunition is typed according to use (Table 4-2). High explosive is used for both fragmentation and blast effect against personnel and light-skinned vehicles. Red phosphorus/white phosphorus is used for screening, producing casualties, creating incendiary effects, and signaling. Illuminating is used for battlefield illumination and signaling. Training practice is used only for training.

	CARTRIDGE				
	M821	M889	M819	M853	M880
TYPE	HE	HE	RP	ILLUM	TP
STANDARD	A	A	A	A	A
MINIMUM RANGE (meters)	83	83	300	300	47
MAXIMUM RANGE (meters)	5,608	5,608	4,875	5,100	458
EFFECTIVE BURSTING AREA	40-meter diameter	40-meter diameter		1,200-meter diameter	
AVERAGE BURN TIME (seconds)				60	
FUZE	M734	M935	M772	M772 M768	M775
COLOR CODING	Olive drab w/yellow markings	Olive drab w/yellow markings	Light green Brown band w/black markings	White with black markings	Blue with white markings

Table 4-2. Types of rounds, classification, and characteristics for the 81-mm mortar, M252.

Note: Standard A ammunition for the M29A1 mortar is Standard B for the M252 mortar (Table 4-3). Standard B ammunition for the M29A1 mortar is Standard C for the M252 mortar.

	CARTRIDGE			
	M374A3	M375A2	M301A3	SABOT

TYPE	HE	WP	ILLUM	TP
STANDARD	A		A	NA
MINIMUM RANGE (meters)	73	70	100	70
MAXIMUM RANGE (meters)	4,800	4,595	3,150	435
EFFECTIVE BURSTING AREA	34-meter diameter		1,100-meter diameter	
AVERAGE BURN TIME (seconds)			60	
FUZE	M524 M526 M532	M524 M526 M567	M84	M744 M745 M746 M747
COLOR CODING	Olive drab w/yellow markings	Light green Yellow band with red markings	White with black markings	Silver metal

Table 4-3. Types of rounds, classification, and characteristics for the 81-mm mortar, M29A1 (Standard B for the 81-mm mortar, M252).

a. **Identification.** All mortar cartridges are painted to prevent rust and to identify their type.

(1) *Marking on container.* The contents of ammunition containers are shown by markings. Additional information is included on an ammunition data card inside each container.

(2) *Color code.* All rounds are colored according to their type.

(3) *Markings on rounds.* Each round is stenciled with the ammunition lot number, type of round, type of filler, and caliber.

b. **Ammunition Lot Number.** An ammunition lot number is assigned to each ammunition lot, which is marked on each cartridge and packing container. It is used for records such as reports on condition, malfunctions, and accidents.

c. **Authorized Cartridges.** The following are authorized (Standard B) cartridges for the 81-mm mortar, M252:

- High explosive--M821, M889, M374-series, and M362.

- Red phosphorus/white phosphorus--M819 and M375-series.
- Illuminating--M853 and M301-series.
- Training practice--M879, M880, M68, and sabot.

4-17. FUNCTION

Each cartridge has fins around the tail to stabilize it in flight and to cause it to strike fuze-end first. The propelling charge consists of an ignition cartridge and removable propellant increments. The ignition cartridge (with primer) is fitted into the base of the fin shaft. The removable increments are fitted onto or around the shaft, depending on their type. The cartridge is dropped down the barrel, fin-end first. The ignition cartridge strikes the firing pin and detonates, which causes a flash that passes through the radial holes in the shaft. The propellant increments are ignited, which produce rapidly expanding gases that force the cartridge from the barrel. The obturating ring ensures equal muzzle velocities in hot or cold barrels by keeping all the gases in the barrel until the cartridge has fired. When fired, the cartridge carries the ignition cartridge with it, leaving the mortar ready for the next cartridge.

4-18. HIGH-EXPLOSIVE AMMUNITION

Several types of HE ammunition are used in the 81-mm mortar, M252. HE ammunition is used against personnel and materiel.

- a. The M821 HE cartridge (M252 only) is a British-made cartridge fitted with the US M734 multioption fuze. It is constructed from ductile cast iron and contains about 1.5 pounds of cyclonite (RDX)/trinitrotoluene (TNT) composition explosive. The aluminum tail assembly has six integral fins equally spaced around the rear, which stabilize the round in flight. The cartridge is painted olive drab with yellow markings. Each cartridge weighs about 10 pounds and is provided with the M223 propelling charge, consisting of four horseshoe-shaped increments fitted around the tail.
- b. The M889 HE cartridge (M252 only XUS Marine Corps) is of the same construction as the M821 cartridge in every detail except the fuze, which is the M935.
- c. The M374A3 HE cartridge is constructed from pearlitic malleable cast iron and contains about 2.10 pounds of composition B explosive. It uses the M205 propelling charge, consisting of four horseshoe-shaped increments fitted around the tail. The cartridge is painted olive drab with yellow markings and weighs about 9.05 pounds. It can be fitted with either the M567, M524, or M532-series fuzes.
- d. The M374A2, M374A1, and M374 HE cartridges are painted olive drab with yellow markings and are constructed from pearlitic malleable cast iron. They contain about 2.10 pounds of composition B explosive. The M374 cartridge is

fitted with the M90 propelling charge. The M374A2 and M374A1 cartridges are fitted with the M90A1 propelling charge. Both the M90 and M90A1 propellants are in nine wax-tested, cotton cloth, bag increments assembled to the tail unit. The cartridge can be fitted with the M524-series, M526-series, M567, or M532 fuzes. Those cartridges assembled with the M524 (A1, A2, A3, or A4) fuze are for use by the US Marine Corps and US Navy only. Cartridges assembled with the M532 fuze must be fired above charge 0. Short cartridges can be expected when firing below charge 4. The cartridge weighs about 9.12 pounds.

e. The M362A1 and M362 HE cartridges are of steel forge construction and contain about 2.10 pounds of composition B explosive. They use the M5 propelling charge that consists of eight cloth bags attached to the tail unit. The cartridges are painted olive drab with yellow markings. They are fuzed with the M524-series, M256-series, or M532. Cartridges assembled with the M524 (A1, A2, A3, or A4) fuze are for use by the U.S. Marine Corps and U.S. Navy only. Cartridges assembled with the M532 fuze must be fired above charge 0. The cartridge weighs about 9.4 pounds.

4-19. RED/WHITE PHOSPHORUS AMMUNITION

Several types of RP/WP ammunition are described herein.

a. The M819 cartridge (M252 only) has a cylindrical body and contains red phosphorus that produces white smoke on contact with air. The cartridge uses the M218 propelling charge, which consists of four horseshoe-shaped increments fitted around the tail. The cartridge is painted light green with black markings and one narrow brown band. It uses the M772 mechanical time fuze and weighs about 10.6 pounds.

Note: Red phosphorus rounds can be fired from the M29/M29A1 at a reduced charge (maximum charge = charge 2). This round may be stored in a horizontal position.

b. The M375A3 cartridge is ballistically similar to the M374A3 (HE) cartridge. It contains white phosphorus that produces white smoke on contact with air. The cartridge is painted light green and has red markings and one narrow yellow band. The cartridge uses the M205 propelling charge and is assembled with the M567 or M524-series fuze. It weighs about 9.05 pounds. This round must be stored in a vertical position.

c. The M375A2, M375A1, and M375 cartridges may also be used. They are painted light green with red markings and one narrow yellow band. They are assembled with either an M524-series, M526-series, or M567 fuze. The M375 cartridge uses the M90 propelling charge while the M375A2 and M375A1 cartridges use the M90A1 propelling charge. Cartridges assembled with the M524 (A1, A2, A3, or A4) fuze are for use by the US Marine Corps and US Navy only.

Short cartridges can be expected when firing below charge 4. This cartridge is ballistically matched to the M374A2, M374A1, and M375 HE cartridges, and weighs about 9.12 pounds.

4-20. ILLUMINATING AMMUNITION

The M853 and M301A3 illuminating ammunition are described herein.

a. The M853 cartridge (M252 only) has a cylindrical body that contains an illuminating candle and parachute assembly. It provides illumination for about 60 seconds with 600,000 candlepower illumination. It is assembled with the M772A1 MTSQ. It uses the M219 propelling charge and weighs about 9.1 pounds.

b. The M301A3 cartridge has a cylindrical body that contains an illuminating candle and parachute assembly. The round has a burst height of 600 meters and provides illumination for about 60 seconds for an area of about 1,200 meters. It is painted white with black markings. It uses the M185 propelling charge that consists of eight increments fitted into the spaces between the fins and held by a propellant holder. The increments are individually wrapped with waterproof bags that are not removed. The cartridge must not be fired below charge 3.

4-21. TYPES OF FUZES

The types of fuzes described in this paragraph are point detonating, proximity, mechanical time, multioption, and dummy.

a. **Point-Detonating.** All PD fuzes are superquick--detonate on impact.

(1) The M935 fuze has two function settings: impact and delay. It is set using the bladed end of the M18 fuze wrench. It is fitted with a standard pull wire and safety pin that are removed immediately before firing.

(2) The M524-series fuze has two function settings: superquick/impact (SQ/IMP) and delay. When set at delay, the fuze train causes a 0.05-second delay before functioning. When set at SQ, the fuze functions on point impact or graze contact. The fuze contains a delayed arming feature that ensures the fuze remains unarmed and detonator safe for a minimum of 1.25 seconds of flight. It arms within a maximum of 2.50 seconds. To prepare for firing, the slot is aligned in the striker with SQ or delay using the M18 fuze wrench. The safety pull wire is removed just before inserting the cartridge into the mortar.

Note: If, upon removal of the safety wire, a buzzing sound in the fuze is heard, the round should not be used. The round is still safe to handle and transport if the safety wire is reinserted.

WARNING

If the plunger safety pin (upper pin) cannot be reinserted, the fuze may be armed. An armed fuze must not be fired since it will be premature. It should be handled with extreme care, and EOD personnel notified immediately. If it is necessary to handle a round with a suspected armed fuze, personnel must hold the round vertically with the fuze striker assembly up.

(3) The M256-series fuze has an SQ/IMP function only. It is fitted with a safety wire and pin that are removed immediately before firing.

(4) The M567 fuze is an impact fuze that has a SQ/IMP or D function. It comes preset to function on SQ/IMP, and the selector slot should align with the SQ mark on the ogive. To set for delay, the selector slot should be rotated clockwise until it is aligned with the "D" mark on the ogive. An M18 fuze wrench is used to change settings. The fuze has a safety wire that must be removed before firing.

b. Proximity (VT). The M532 fuze is a radio doppler fuze that has a proximity (PROX) or SQ/IMP function. An internal clock mechanism provides nine seconds of safe air travel (610 to 2,340 meters along trajectory for charge 0 through 9, respectively). Once set to act as an impact fuze, the mechanism cannot be reset for PROX. The fuze arms and functions normally when fired at any angle of elevation between 0800 and 1406 mils at charges 1 through 9. The fuze is not intended to function at charge 0. However, at temperatures above 32 degrees Fahrenheit and at angles greater than 1068 mils, the flight time is sufficient to permit arming. To convert the fuze from PROX to SQ/IMP, the top of the fuze must be rotated 120 degrees (one-third turn) in either direction. This action breaks an internal sheet pin and internal wire, thereby disabling the proximity function.

c. Mechanical Time. These fuzes use a clockwork mechanism to delay functioning for a specific time.

(1) The M772A1 fuze is a MTSQ. It can be set from 3 to 55 seconds at half-second intervals. The settings are obtained from the range tables and are applied using a wrench (number 9239539) or a 1 3/4-turn open-end wrench. The safety wire must be removed before firing.

(2) The M84 fuze is a single-purpose, powder-train, mechanical-time fuze used with the 81-mm M301A1 and M301A2 illuminating cartridges. It has a time setting of up to 25 seconds. The fuze consists of a brass head, body assembly, and expelling charge. The fuze body is graduated from 0 to 25 seconds in 1-second intervals; 5-second intervals are indicated by bosses. The 0-second boss is wider and differs in shape from the other body

bosses; the safe setting position is indicated by the letter "S" on the fuze body. The adjustment ring has six raised ribs for use in conjunction with fuze setter, M25, and a setting indicator rib (marked SET) about half the height and width of the other six ribs. Safety before firing is provided by a safety wire, which must be removed just before firing.

(3) The M84A1 fuze is a single-purpose, tungsten-ring, mechanical-time fuze used with the 81-mm M301A3 illumination cartridge. It has a time setting of up to 50 seconds. The fuze consists of a brass head, body assembly, and expelling charge. The fuze body is graduated from 0 to 50 seconds in 2-second intervals; 10-second intervals are indicated by bosses. The 0-second boss is wider and differs in shape from the other body bosses; the safe setting position is indicated by the letter "S" on the fuze body. The adjustment ring has six raised ribs for use in conjunction with fuze setter, M25, and a setting indicator rib (marked SET) about half the height and width of the other six ribs. Safety before firing is provided by a safety wire, which must be removed just before firing.

d. **Multioption.** The M734 multioption fuze is the only one used with the 81-mm mortar. It has four function settings: PRX (proximity) causes the cartridge to explode between 3 and 13 feet above the ground; NSB (near-surface burst) causes the cartridge to explode up to 3 feet above the ground; IM (impact) causes the cartridge to explode on contact; and DLY (delay) incorporates a 0.05-second delay in the fuze train before exploding the cartridge. No tools are needed to set the fuze, and the setting can be changed several times without damaging the fuze. It has no safety pins or wires to reduce preparation time. If the fuze does not function as set, it automatically functions at the next lower setting.

e. **Dummy.** The M751 fuze is the only dummy fuze used with the 81-mm mortar. It has two types: type 1 resembles the M734 fuze, and type 2 resembles the M935 fuze. The M751 is fitted with a smoke charge that operates on impact. The safety/packing clip should be removed when the cartridge is unpacked.

4-22. CHARACTERISTICS OF PROXIMITY FUZES

A proximity fuze is an electronic device that detonates a projectile by means of radio waves sent out from a small radio set in the nose of the projectile.

a. **Disposal Precautions.** Proximity-fuzed short cartridges, which are duds, contain a complete explosive train and impact element. They should not be approached for 5 minutes or disturbed for at least 30 minutes after firing. After the 30-minute waiting period, the dud is still dangerous but can be approached and removed carefully or destroyed in place by qualified disposal personnel. If the situation allows for a longer waiting period, the dud can be considered safe for handling after 40 hours.

b. **Burst Height.** The principal factors affecting height of burst are the angle of approach to the target and the reflectivity of the target terrain. The air burst over average types of soil ranges from 1 to 6 meters, depending on the angle of approach. High angles of approach (near vertical) give the lowest burst heights. Light tree foliage and light vegetation affect the height of burst only slightly, but dense tree foliage and dense vegetation increase the height of burst. Target terrain, such as ice and dry sand, gives lowest burst heights, whereas water and wet ground give highest burst heights.

c. **Crest Clearance.** Close approach to crests, trees, towers, large buildings, parked aircraft, mechanized equipment, and similar irregularities causes malfunctioning at heights greater than average level. When targets are beyond such irregularities, a clearance of at least 30 meters should be allowed to ensure maximum effect over the target area.

d. **Climatic Effects.** The fuzes may be used for day or night operations. They function normally in light rain; however, heavy rain, sleet, or snow can cause an increase in the number of early bursts. At extreme temperatures (below -40 degrees Fahrenheit and above 125 degrees Fahrenheit), it is not unusual to experience an increase in malfunctions proportionate to the severity of conditions.

e. **Care, Handling, and Preservation.** Proximity fuzes withstand normal handling without danger of detonation or damage when in their original packing containers or when assembled to projectiles in their packing containers.

WARNING

The explosive elements in primers and fuzes are sensitive to shock and high temperatures. Boxes containing ammunition should not be dropped, thrown, tumbled, or dragged.

f. **Installation.** The fuze should already be fitted to the cartridge. If not, the cartridge is placed on its side, and the closing plug is removed using an M18 fuze wrench. (The handle of the wrench is turned counterclockwise.) The fuze threads and fuze well threads are inspected for damage. The fuze is screwed into the cartridge body, and it is seated and secured using an M18 wrench. There must not be a visible gap between the fuze and cartridge body.

WARNING

Do not use the fuze if the thread(s) is damaged. Do not use the cartridge if the fuze well is damaged or if the explosive is visible on the thread.

4-23. FUZE WRENCH AND FUZE SETTER

The fuze wrench, M18, assembles the fuze to the cartridge, and the bladed tip on the end sets PD-type fuzes. The wrench (P/N 9349539) sets M772 MT and M768 time fuzes. It engages the 1 3/4-inch flats on the setting ring or the fuze head. The fuze setter, M25, sets M84-series time fuzes. Notches in the setter engage ribs in the setting ring of the fuze.

4-24. PREPARATION OF AMMUNITION

The propellant train (except the training cartridge) consists of an ignition cartridge and propellant charges. The ignition cartridge has a percussion primer and is assembled to the end of the fin assembly. The propelling charge is contained in four horseshoe-shaped, felt-fiber containers or nine wax-tested, cotton cloth, bag increments. The propelling charges are assembled around the fin assembly shaft.

a. Cartridges are shipped with a complete propelling charge, an ignition cartridge, and primer. Firing tables are used to determine the correct charge for firing. Remaining increments are repositioned towards the rear of the tail fin assembly when firing the cartridge with horseshoe-shaped increments at less than full charge.

Note: Charge 0--Ignition cartridge only.
Charge 1--Ignition cartridge and one increment.
Charge 2--Ignition cartridge and two increments.
Charge 9--Ignition cartridge and nine increments

b. Increments removed from cartridges before firing should be placed in a metal or wooden container located outside the firing vehicle/position at least 25 meters away. Excess increments should not accumulate near the mortar positions but are removed to a designated place of burning and destroyed. Check the post SOP before applying the following procedure:

- (1) Select a place at least 100 meters from the mortar position, parked vehicles, and ammunition piles.
- (2) Burn all dead grass or brush within 30 meters around the burning place. Do not burn increments in piles but spread them in a train 1 to 2 inches deep, 4 to 6 inches wide, and as long as necessary.
- (3) From this train, extend a starting train that will burn against the wind of single increments laid end to end. End this starting train with not less than 1 meter of inert material (dry grass, leaves, or newspapers).
- (4) Ignite the inert material.

- (5) Do not leave unused increments unburned in combat operational areas. The enemy will use them.

4-25. CARE AND HANDLING

Ammunition is made and packed to withstand all conditions ordinarily encountered in the field. However, since explosives are affected by moisture and high temperature, they must be protected.

a. Before-firing checks include the following:

- (1) Ammunition should be free of moisture, rust, and dirt.
- (2) The fin and fuze assembly must be checked for tightness and damage.
- (3) Charges must be kept dry.
- (4) Extra increments are removed if the cartridge is to be fired with less than full charge.
- (5) With the exception of a few unused increments (within the same ammunition lot number) as replacements for defective increments, excess powder should be removed from the mortar position.
- (6) The primer cartridge is checked for damage or dampness.
- (7) When opening an ammunition box, the ammunition bearer ensures the box is horizontal to the ground, not nose- or fin-end up. After the bands are broken and the box opened, the rounds should be removed by allowing them to roll out along the lid of the box (Figure 4-8). After the rounds have been removed, they should always be handled with two hands to prevent accidental dropping. Dropping may cause the propellant charges to ignite, causing bodily injuries.

WARNING

Incidents occurring from mishandling 300-series ammunition have resulted in minor burns to the hands and legs.

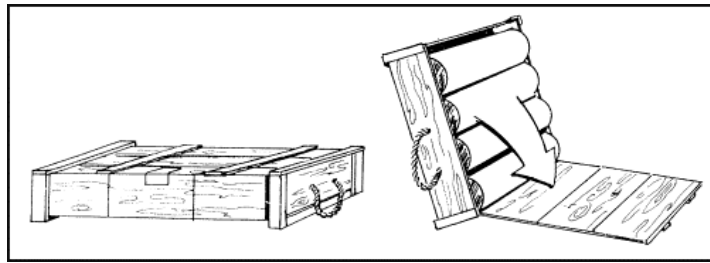

Figure 4-8. Correct way to open an ammunition box.

Note: The floating firing pin located within the primer has approximately 1/16 of an inch to move around. This may cause the firing pin to ignite the charges if the cartridge is dropped on the fin end (Figure 4-9).

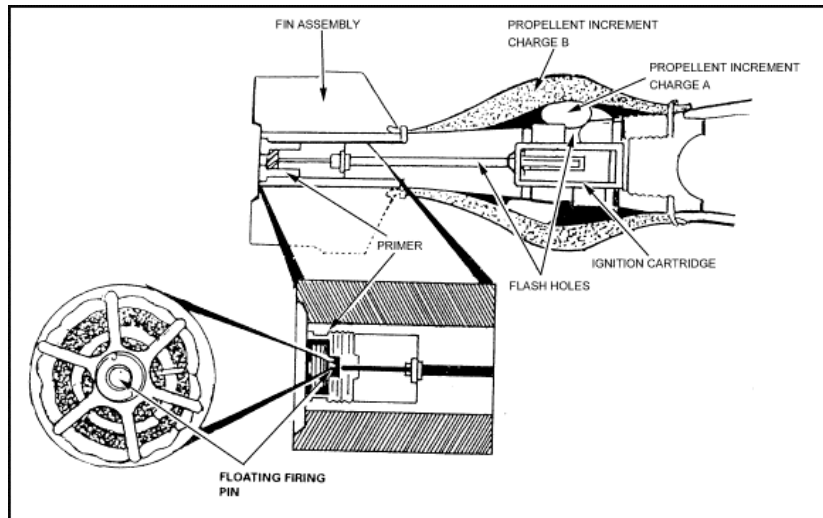

Figure 4-9. Floating firing pin.

(8) To help minimize the occurrence of short rounds and or duds, unpackaged ammunition that has been dropped should not be fired. It should be destroyed in accordance with standard procedures.

DANGER

M800-SERIES CARTRIDGES (HE, TP, SMOKE, AND ILLUMINATION) ARE AUTHORIZED FOR FIRING IN THE 81-mm, M29-SERIES MORTARS ONLY AT CHARGE 3 OR BELOW. FIRING THE M800-SERIES CARTRIDGES ABOVE CHARGE 3 CAN CAUSE CATASTROPHIC FAILURE OF THE MORTAR TUBE RESULTING IN PERSONNEL INJURY OR DEATH.

- b. Complete cartridges are always handled with care. The explosive elements in primers and fuzes are sensitive to shock and high temperature. Fuzes are not disassembled.
- c. The moisture-resistant seal of the container is broken when the ammunition is to be used. When a large number of cartridges are needed for a mission, they may be removed from the containers and prepared. Propelling charges are covered or protected from dampness or heat.
- d. The ammunition is protected from mud, sand, dirt, and water. If it gets wet or dirty, it must be wiped off at once. The powder increments, mainly, should not be exposed to direct sunlight. More uniform firing is obtained if ammunition is kept at the same temperature.
- e. The pull wire and safety wire are removed from the fuze just before firing. When cartridges have been prepared for firing, but are not used, all powder increments and safety wires are replaced. The cartridges are returned to their original containers. These cartridges are used first in subsequent firing so that once-opened stocks can be kept to a minimum.

WARNING

Do not handle duds; the fuzes could be armed. Duds are extremely dangerous. Do not move or turn them. To dispose of duds, immediately call the nearest EOD unit.

- f. Ammunition should be stored under cover. If it is necessary to leave the ammunition uncovered, it should be raised on dunnage at least 6 inches above the ground. The pile is covered with a double thickness of tarpaulin. Trenches are dug to prevent water from flowing under the pile. WP cartridges are stored with the fuze end up. Since phosphorus liquefies at about 100 degrees Fahrenheit, the ammunition is protected against an uneven rehardening of the filler. An air cavity can form on one side of a cartridge to unbalance it, causing instability in flight. Red phosphorus cartridges (M252 only) are stored the same as HE cartridges.

WARNING

When firing HE ammunition less than 400 meters, personnel must have adequate cover for protection from fragments.

DANGER

M800-SERIES AMMUNITION IS NOT AUTHORIZED FOR FIRING IN THE 81-mm MORTAR, M1.

CHAPTER 5

81-mm MORTAR, M29A1

The 81-mm mortar, M29A1, delivers timely, accurate fires to meet the requirements of supported troops. This chapter discusses personnel duties, mechanical training, and the characteristics of the mortar.

Section I. SQUAD AND SECTION ORGANIZATION AND DUTIES

Each member of the infantry mortar squad has principle duties and responsibilities. (See FM 7-90 for platoon drills.)

5-1. ORGANIZATION

For the 81-mm mortar section to operate effectively, each mortar squad member must be proficient in his individual duties. By performing those duties as a team member, he enables the mortar squad and section to perform as a fighting team. The platoon leader commands the platoon and supervises the training of the elements. He uses the chain of command to assist him in effecting his command and supervising duties.

5-2. DUTIES

The mortar squad consists of five men (Figure 5-1). Their firing positions and principal duties are as follows:

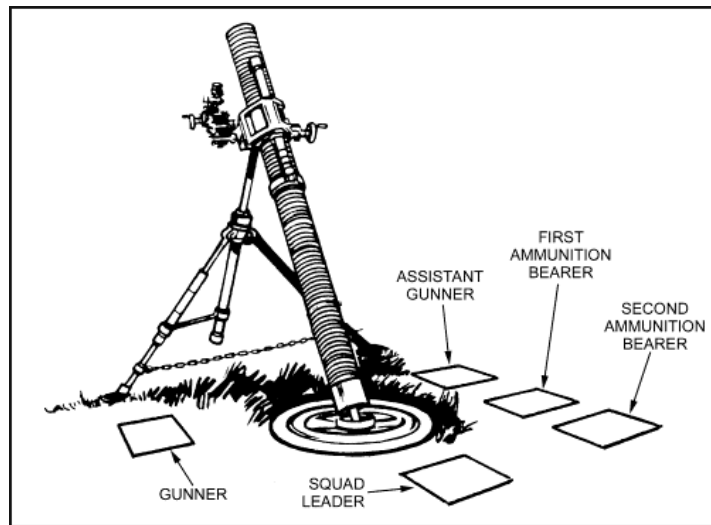

Figure 5-1. Positions of squad members.

- a. The *squad leader* stands behind the mortar where he can command and control his squad. In addition to supervising the emplacement, laying, and firing of the mortar, he supervises all other squad activities.
- b. The *gunner* stands on the left side of the mortar where he can manipulate the sight, elevating gear handle, and traversing assembly wheel. He places firing data on the sight and lays the mortar for deflection and elevation. He and assistant gunner make large deflection shifts by shifting the bipod assembly.
- c. The *assistant gunner* stands on the right of the mortar, facing the barrel and ready to load. In addition to loading, he is responsible for swabbing the bore after every 10 rounds have been fired or after each fire mission. He assists the gunner in shifting the mortar when making large deflection changes.
- d. The *first ammunition bearer* stands to the right rear of the mortar. He prepares the ammunition and passes it to the assistant gunner.
- e. The *second ammunition bearer* is normally behind the mortar, maintaining the ammunition for firing, providing local security for the mortar position, filling sandbags, and performing other duties as the squad leader directs. He normally places out and retrieves the aiming post. The second ammunition bearer is also the squad truck driver. When his duties do not require him to be with the vehicle, he

is used as an ammunition bearer (performing the same duties as the first ammunition bearer).

Section II. COMPONENTS

This section contains the technical data and description of each component of the 81-mm mortar, M29A1. The 81-mm mortar is a smooth-bore, muzzle-loaded, high angle-of-fire weapon (Figure 5-2). It consists of a cannon assembly, bipod assembly, and baseplate.

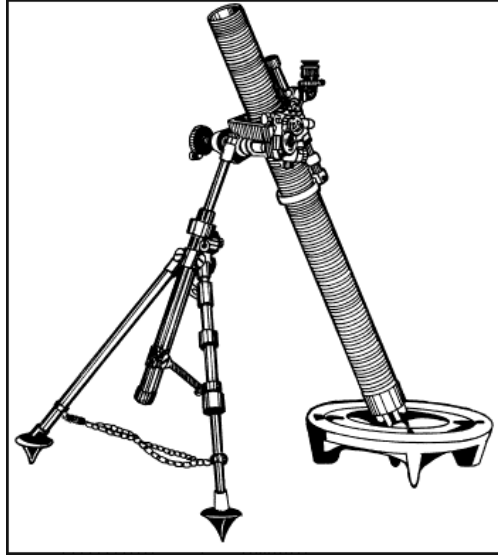

Figure 5-2. 81-mm mortar, M29A1.

5-3. TABULATED DATA

The tabulated data for the 81-mm mortar, M29A1, are as shown in Table 5-1.

Weights (pounds)	
System (including basic issue items)	121.5 (total in three loads)
Barrel	28
Mount	40
M3 Baseplate	25.4
M23A1 Baseplate	48
M53 Sightunit	5.25

Ammunition	<u>HE</u>	<u>Smoke</u>	<u>Illum</u>	<u>Practice</u>
Ready to fire	9.4	10.6	9.1	9.4
In single container	12.0	13.8	12.4	12.5
In three-round pack	57.0	63.0	60.0	60.0
<i>Note: M3 baseplate is standard A.</i>				
Elevation				
Elevation (approximate)	800 to 1511 mils			
For each turn of elevation crank (approximate)	10 mils			
Traverse				
Right or left from center (approximate)	95 mils (9 2 turns)			
Total turns of handwheel for full traverse (approximate)	190 mils (19 turns)			
Total traverse by movement of mount without moving baseplate	6400 mils			
Range				
Minimum to maximum	70 to 4,737 meters			
Rate of Fire				
Sustained	3 (charge 8) to 5 (charge 6) rounds per minute for 1 minute			
Maximum for 2 minutes	12 (charge 8) rounds per minute			
Maximum for 5 minutes	12 (charge 6) rounds per minute			
HE Lethality (M374 series)	34-meter diameter			
Smoke Screen (M375 series)	20-meter diameter			
Illumination (M301A3)	500,000 candlepower for 1 minute (1,200-meter area illuminated)			
HE Fuze Options	M524 PD, M536 PD, M532 proximity			
Sight	M53 series			

Table 5-1. Tabulated data.

5-4. CANNON ASSEMBLY, M29A1

The cannon assembly consists of the barrel, mount attachment ring, and base plug with a spherical projection that contains a removable firing pin (Figure 5-3).

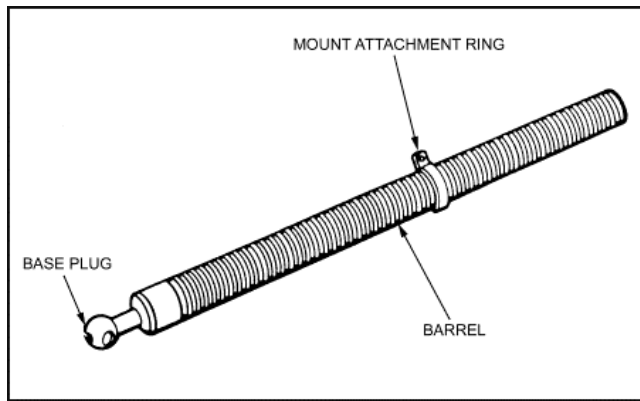

Figure 5-3. Cannon assembly, M29A1.

5-5. BIPOD ASSEMBLY, M23A1

The bipod assembly consists of the elevating and traversing mechanism, and bipod legs (Figure 5-4).

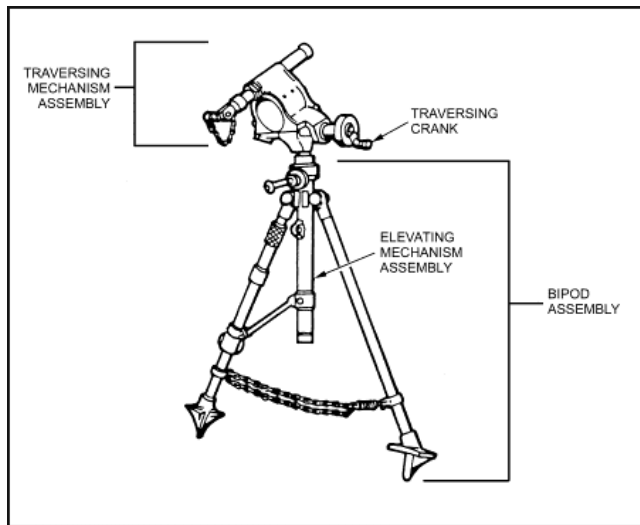

Figure 5-4. Bipod assembly, M23A1.

a. The *bipod legs* consist of two tubular steel legs that are hinged at the sides of the elevating mechanisms. The legs have spiked feet, and their spread is limited by an adjustable chain. A spring attached to the right end of the chain and the right leg relieves shock to the legs during firing. The right leg has no moving parts. The left leg has a cross-level mechanism consisting of a sliding bracket mounted on the leg with a locking sleeve and adjusting nut. The sliding bracket is connected to the elevating housing by a connecting rod. Any movement of the sliding bracket is transmitted through the connecting rod, elevating mechanism assembly, and traversing mechanism assembly to the barrel, moving it in a like manner. The locking nut locks the sliding bracket in any desired position on the leg. Cross-leveling is performed to remove any cant from the sight. The sight must be level to attain true readings in elevation and deflection. Cross-leveling is completed by rotating the adjusting sleeve on the upper part of the leg.

b. The *elevating mechanism* assembly includes a vertical spindle screw moving in an elevating housing assembly. The screw is turned by a bevel gear and pinion contained in the gear case. The gear and pinion are moved by an elevating crank. The top cover of the gear case contains an oil fitting for oiling the elevating screw, gear, and pinion.

c. The *traversing mechanism* consists of the yoke assembly, traversing mechanisms, and shock absorber. The yoke body supports the upper end of the barrel when the mortar is assembled.

Note: Older models of the yoke contain a level vial.

d. The sightunit is mounted in the dovetail sight slot on the left side of the yoke. The traversing mechanism is an internal screw shaft operating within a nut and tube. The handwheel turns the screw, which forces the nut to traverse the yoke and, therefore, the barrel. The tube over the nut is connected to the elevating shaft, which protrudes from the gear case of the bipod. The shock absorber is a compression spring-type unit mounted in the yoke. A shock absorber clevis screws to the projecting end of the shock absorber shaft. When the barrel is assembled to the yoke, this clevis is attached to the barrel ring with the shock absorber clevis locking pin.

5-6. BASEPLATE, M3

The baseplate (Figure 5-5) is of one-piece construction, and supports and aligns the mortar for firing. During firing, the base plug on the barrel is seated and locked to the rotatable socket in the baseplate. The barrel passes through the yoke of the mount and is secured to the shock absorber by a locking pin.

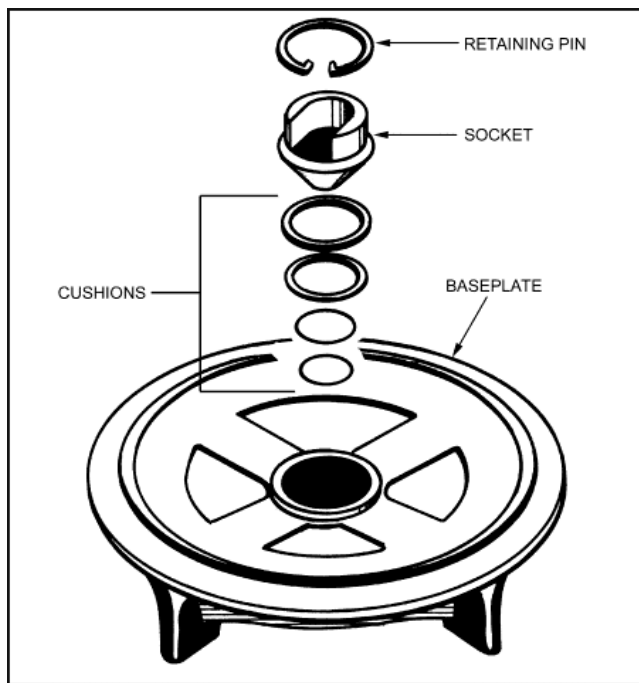

Figure 5-5. Baseplate, M3.

Section III. OPERATION

This section contains information on how to prepare the 81-mm mortar, M29A1, for firing, and how to conduct safety checks and misfire procedures.

5-7. PREMOUNT CHECKS

Before the mortar is mounted, the squad must perform premount checks. Each squad member should be able to perform the following premount checks:

- a. The *gunner* checks the mount and ensures that--
 - (1) The spread chain is doubled, wrapped around the legs, and hooked, untangled, to the left leg.
 - (2) The clearance on the left leg above the adjusting sleeve is two fingers in width.

(3) The locking nut is neither too loose nor too tight.

(4) The traversing bearing is centered.

(5) The clevis locking pin is fully seated.

b. The *assistant gunner* checks the barrel and ensures that--

(1) The barrel ring is centered between the two beveled cutouts on the outer ring.

(2) The barrel is clean both inside and outside.

(3) The firing pin is visible.

(4) The spherical projection is clean and the firing pin is firmly seated.

c. The *first ammunition bearer* checks the baseplate and ensures that--

(1) The rotatable socket cap moves freely and has a light coat of oil.

(2) The ribs and braces are free from breaks and dents, and the inner ring is secured to the outer ring (M23A1 baseplate).

d. After each piece of equipment is checked, the squad members notify the gunner that either the baseplate (or cannon) is correct or they report what is wrong with that piece of equipment.

e. The *squad leader* supervises the conduct of squad drill and is responsible for supervising the laying out of the equipment as shown in Figure 5-6. The equipment is placed out the same for the gunner's examination.

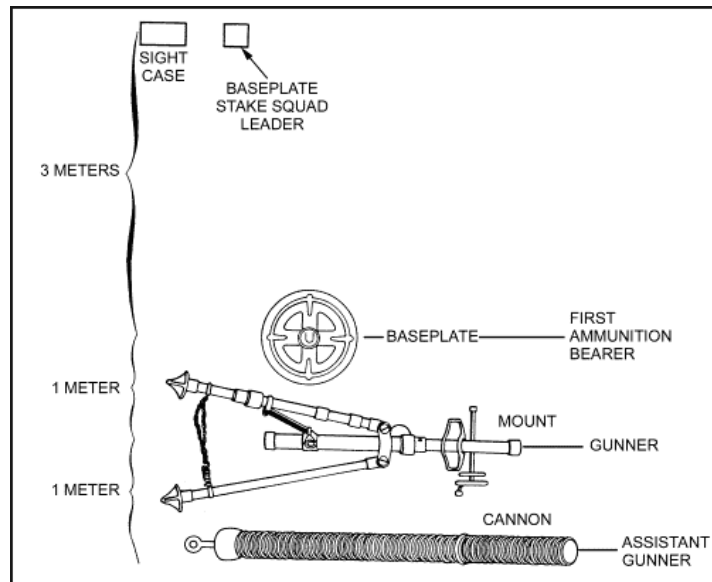

Figure 5-6. Layout of equipment.

5-8. MOUNTING OF THE MORTAR

The squad leader picks up the sight case and two aiming posts, and moves to the exact position where the mortar is to be mounted. He places the sight case and aiming posts to the left front of the mortar position. The squad leader points to the exact spot where the mortar is to be mounted. He indicates the initial direction of fire by pointing in that direction and commands ACTION.

- a. The first ammunition bearer places the outer edge of the baseplate against the baseplate stake, so that the left edge of the cutout portion of the baseplate is aligned with the right edge of the stake (Figure 5-7). He then rotates the socket cap so that its open end is pointing in the direction of fire.

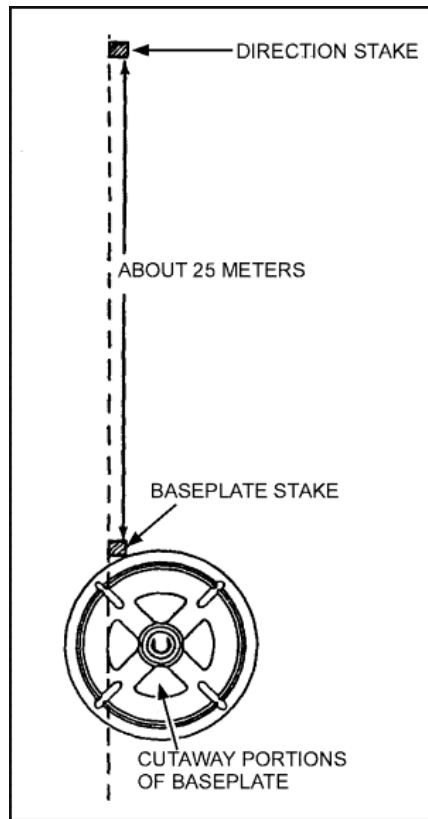

Figure 5-7. Baseplate placed against baseplate stake.

b. When the baseplate is in position, the gunner places his left hand on the traversing handwheel and his right hand on the sight slot, and lifts the bipod. He moves to the front, faces the baseplate, and places the bipod legs about 12 to 15 inches in front of the baseplate on line with the right edge so that an extension of the right edge of the baseplate would bisect the interval between the closed legs. Kneeling on his right knee in front of the bipod and supporting it with his left hand on the gear case, the gunner unhooks the doubled chain from the chain hook on the left leg, unwinds it, and rehooks the end loop on the chain hook. Lifting the left leg, he opens the legs to the full extent of the chain.

c. The gunner moves the elevating mechanism housing to the left until the traversing mechanism is in a horizontal position, and then tightens the locking sleeve.

d. The gunner rises and moves to the left rear of the bipod while supporting the bipod with his left hand on the shock absorber. He disengages the clevis locking pin and raises the yoke assembly to a horizontal position, keeping both hands on the shock absorber. He holds the clevis locking pin and chain out of the way with his right hand.

e. The assistant gunner inserts the barrel (mount attachment ring lug up and centered between the two beveled cutouts on the outer ring) into the yoke assembly with a slight twisting motion until the lug on the mount attachment ring fits into the shock absorber clevis (Figure 5-8). The gunner locks the clevis to the barrel ring with the clevis locking pin. The assistant gunner inserts the spherical projection of the base plug into the socket and rotates the barrel 90 degrees to lock it to the baseplate.



Figure 5-8. Bipod and mount attachment ring secured.

f. The gunner then places the traversing crank in its operating position. Removing the sight from its case, he mounts it on the mortar and sets it at a deflection of 3200 mils and an elevation of 1100 mils. He centers the elevation level bubble, centers the cross-level bubble, and rechecks the elevation bubble.

5-9. SAFETY CHECKS BEFORE FIRING

The following safety checks must be enforced before firing the mortar.

- a. The *gunner* makes certain that--
 - (1) There is mask and overhead clearance.

(a) Since the mortar is normally mounted in defilade, there may be a mask such as a hill, trees, a building, or a rise in the ground. Overhead interference can be caused by overhanging branches of trees or roofs of buildings. However, the gunner must ensure that the round does not strike an obstacle.

(b) In selecting the exact mortar position, the leader checks quickly for mask clearance and overhead interference. After the mortar is mounted, the gunner makes a thorough check.

(c) The gunner determines mask and overhead clearance by sighting along the top of the barrel with his eye placed near the base plug. If the line of sight clears the mask, it is safe to fire. If not, he can still fire at the desired range by selecting a charge zone having a higher elevation. When firing under the control of an FDC, he reports to the FDC that mask clearance cannot be obtained at a certain elevation.

(d) Firing would be slowed if mask clearance had to be checked before each firing but this can be eliminated if minimum mask clearance is determined. This is accomplished by depressing the barrel until the top of the mask is sighted. The gunner levels the elevation bubble and reads the setting on the elevation scale and elevation micrometer--this setting is the minimum mask clearance. The squad leader notifies the FDC of the minimum mask clearance elevation. Any target that requires that elevation, or a lower one, cannot be engaged from that position.

(e) If the mask is not regular throughout the sector of fire, the gunner determines the minimum mask clearance as described above. Placing the mortar in position at night does not relieve the gunner of the responsibility of checking for mask clearance and overhead interference.

(2) The barrel is locked to the baseplate with the open end of the socket cap pointing in the direction of fire. The barrel ring should be positioned between the etched markings on the barrel.

(3) The shock absorber clevis locking pin is secure.

(4) The locking sleeve is wrist tight.

(5) The chain is taut and is hooked to the left leg.

b. The *assistant gunner* ensures that the bore is clean, and he swabs the bore dry.

- c. The *ammunition bearer* ensures that each round is clean, the safety pin is present, and the ignition cartridge is in good condition.

5-10. SMALL DEFLECTION AND ELEVATION CHANGES

With the mortar mounted and the sight installed, the gunner lays the sight on the two aiming posts (placed out 50 and 100 meters from the mortar) on a referred deflection of 2800 mils and an elevation of 1100 mils. The mortar is within two turns of center of traverse. The vertical cross line of the sight is on the left edge of the aiming post.

- a. The gunner is given a deflection change in a fire command between 20 and 60 mils. The elevation change announced must be less than 90 mils and more than 35 mils.
- b. As soon as the sight data are announced, the gunner places it on the sight, lays the mortar for elevation, and then traverses onto the aiming post by turning the traversing handwheel and the adjusting nut in the same direction. A one-quarter turn on the adjusting nut equals one turn of the traversing handwheel. When the gunner is satisfied with his sight picture, he announces, "Up."

Note: All elements given in the fire command are repeated by the gunner.

- c. After the gunner has announced, "Up," the mortar should be checked by the squad leader to determine if the exercise was performed correctly.

5-11. LARGE DEFLECTION AND ELEVATION CHANGES

With the mortar mounted and the sight installed, the gunner lays the sight on the two aiming posts (placed out 50 and 100 meters from the mortar) on a referred deflection of 2800 mils and an elevation of 1100 mils.

- a. The gunner is given a deflection and elevation change in a fire command causing the gunner to shift the mortar between 200 and 200 mils and an elevation change between 100 and 200 mils.
- b. As soon as the sight data are announced, the gunner places it on the sight, elevates the mortar until the elevation bubble floats freely, and then centers the traversing bearing. This ensures a maximum traversing capability after making the movement.
- c. The assistant gunner moves into position to the front of the bipod on his right knee, places his right shoulder against the gear case, and grasps the bipod legs (palms out), lifting until they clear the ground enough to permit lateral movement. The gunner moves the mortar while the assistant gunner steadies it. The gunner attempts to horizontally maintain the traversing mechanism. To make the shift,

the gunner places the fingers of his right hand in the muzzle (Figure 5-9), his left hand on the left leg, and moves the mortar until the vertical line of sight is aligned approximately on the aiming post. When the approximate alignment is completed, the gunner signals the assistant gunner to lower the bipod by pushing down on the mortar.



Figure 5-9. Large deflection changes.

5-12. REFERRING OF THE SIGHT AND REALIGNMENT OF AIMING POSTS USING M53 SIGHT

Referring and realigning aiming posts ensure that all mortars are set on the same data. The section leader, acting as FDC, has one deflection instead of two.

a. The mortar is mounted and the sight is installed. The sight is laid on two aiming posts (placed out 50 and 100 meters from the mortar) on a referred deflection of 2800 mils and an elevation of 1100 mils. The mortar is within two turns of center of traverse. The gunner is given an administrative command to lay the mortar on a deflection of 2860 or 2740 mils. The mortar is then re-laid on the aiming posts using the traversing crank.

b. The gunner is given a deflection change between 5 and 25 mils, either increasing or decreasing from the last stated deflection, and the command to refer and realign aiming posts.

EXAMPLE: REFER DEFLECTION TWO EIGHT SEVEN FIVE (2875),
REALIGN AIMING POST.

c. Upon receiving the command REFER, REALIGN AIMING POST, two actions take place at the same time in the mortar squad. The gunner places the announced deflection on the sight (without disturbing the lay of the weapon) and looks through the sightunit. Also, the first ammunition bearer moves out to realign the aiming posts. He knocks down the near aiming post and proceeds to the far aiming post. Following the arm-and-hand signals of the gunner (who is looking through the sightunit), he moves the far aiming post so that the gunner obtains an aligned sight picture. The same procedure for aligning the far aiming post is used to align the near aiming post.

5-13. MALFUNCTIONS

See Chapter 3, paragraph 3-14 for a detailed discussion of malfunctions.

5-14. REMOVAL OF A MISFIRE

When a misfire occurs, any member of the squad immediately announces, "Misfire." The entire squad stays with the mortar. The gunner then kicks the barrel several times with his heel in an attempt to dislodge the round. If the round fires, the mortar is re-laid on the aiming point and firing is continued.

WARNING

During peacetime live -fire training, all personnel, except the gunner, move at least 50 meters to the rear of the mortar.

a. If the round does not fire, the gunner tests the barrel for heat. After one minute, if the barrel is cool enough to handle, the crew removes the round as described below. If the barrel is hot, the gunner may then apply water to the outside of the

barrel until it is cool. If no water is available, the gunner stands clear of the mortar until the barrel is cool.

WARNING

During peacetime live -fire training, if the round does not fire, the gunner joins the crew and waits one minute to avoid personal injury due to a cookoff. After waiting one minute, the gunner returns to the mortar and tests the barrel for heat. When the barrel is cool enough to handle, the gunner signals for the rest of the crew to come forward.

b. After the barrel cools, the gunner removes the sight and depresses the barrel to the minimum elevation. The assistant gunner braces the right leg of the bipod by placing his left leg in front of it. The gunner rotates the barrel while ensuring that he is positioned beside not behind, the weapon, until it is unlocked from the baseplate. The assistant gunner then places his right hand, palm up, under the barrel near the muzzle, and his left hand, palm down, on top of the barrel. He places the thumbs of both hands alongside the forefingers, being careful to keep both hands hand away from the muzzle.

c. The gunner lifts the base of the barrel until it is horizontal. He never lowers the base of the barrel below a horizontal position before the round has been removed. As soon as the barrel is in the horizontal position, and not before, the assistant gunner places the meaty portion of the thumb of each hand over the muzzle. When the fuze reaches the muzzle, the assistant gunner stops the round with his thumbs (avoiding the fuzes). He then carefully removes the round and passes it to the first ammunition bearer who inspects it to determine the cause of the misfire. If the primer of the ignition cartridge is dented, the ammunition bearer replaces the safety wire (if applicable) and places the round in a marked, safe location for disposition by ordnance personnel. If the primer is not dented, the round can be used again. The gunner shakes the barrel to dislodge any remnants from the last round fired, then locks the barrel.

d. If the procedure above fails to remove the misfire, the barrel must be kept horizontal. Then it is removed from the bipod and laid horizontally on the ground at the dud pit or safe area until it can be turned over to ordnance for disposal.

5-15. DISMOUNTING OF THE MORTAR

To dismount the mortar, the squad leader commands, OUT OF ACTION. At this command, the squad proceeds as follows:

a. The *second ammunition bearer* retrieves the aiming posts. The gunner removes the sight and places it in the sight box. He places an elevation of 800 mils and a

deflection of 3800 mils on the M53 sightunit. Then he lowers the mortars to its minimum elevation.

b. The *assistant gunner* turns the barrel 90 degrees, lifts up on the base end of the barrel and removes the barrel from the yoke assembly. He then turns to his left and places the barrel in the area designated by the squad leader.

c. The *gunner* disengages the clevis locking pin. He moves to the front of the bipod and faces it, kneels on his right knee with his left hand on the gear case, loosens the locking nut, and unhooks the chain from the left leg. He tilts the bipod to his left and closes the bipod legs, placing the chain around the legs and rehooking the chain. He stands up, placing his right hand on the sight slot and left hand on the traversing handwheel.

d. The *squad leader* picks up the aiming posts and sight. At the command MARCH ORDER, the squad places the mortar, equipment, and ammunition in the squad vehicle and trailer.

Section IV. AMMUNITION

This section implements STANAG 2321 and QSTAG 900 (Edition 1).

The ammunition that can be fired by the 81-mm mortar, M29A1, is identified and described herein. Ammunition is typed according to use (see Chapter 4, Table 4-2). High explosive is used against personnel and light-skinned vehicles. White phosphorus is used for screening, producing casualties, incendiary action, and signaling. Illuminating is used for battlefield illumination and signaling. Training practice is only for training.

The following are authorized cartridges for the 81-mm mortar, M29A1:

- High explosive--M374 series and M362 series.
- White phosphorus--M375 series, M370 series, and M57 series.
- Illuminating--M301 series.
- Training practice--M68 and M880 (SRTR).

The M29A1 may fire M821, M889, and M819 at reduced charges: charge 2 for training and charge 3 for combat.

Note: For a discussion of identification and ammunition lot numbers of cartridges, see Chapter 4, Section IV.

5-16. FUNCTION

Each cartridge has fins around the tail to stabilize it in flight and to cause it to strike fuze-end first. The propelling charge consists of an ignition cartridge and removable propellant

increments. The ignition cartridge (with primer) is fitted into the base of the fin shaft. The removable increments are fitted onto or around the shaft, depending on their type. The cartridge is dropped down the barrel, fin-end first. The ignition cartridge strikes the firing pin and detonates, which causes a flash that passes through the radial holes in the shaft. The propellant increments are ignited, which produce rapidly expanding gases that force the cartridge from the barrel. The obturating ring ensures equal muzzle velocities in hot or cold barrels by keeping all the gases in the barrel until the cartridge has fired. When fired, the cartridge carries the ignition cartridge with it, leaving the mortar ready for the next cartridge (Figures 5-10 and 5-11).

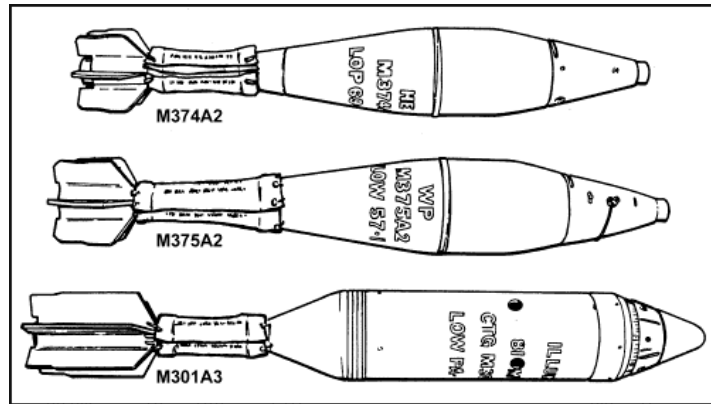

Figure 5-10. Standard A ammunition for 81-mm mortar, M29A1.

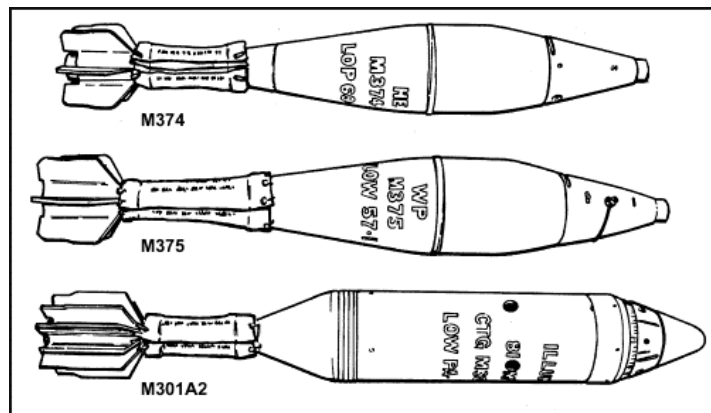

Figure 5-11. Standard B ammunition for 81-mm mortar, M29A1.

5-17. HIGH-EXPLOSIVE AMMUNITION

For a description of the types of HE ammunition, see Chapter 4, paragraph 4-18.

5-18. WHITE PHOSPHORUS AMMUNITION

For a description of the types of WP ammunition, see Chapter 4, paragraph 4-19.

5-19. ILLUMINATING AMMUNITION

For a description of the types of illuminating ammunition, see Chapter 4, paragraph 4-20.

5-20. TYPES OF FUZES

For a description of the types of fuzes, see Chapter 4, paragraph 4-21.

5-21. CHARACTERISTICS OF PROXIMITY FUZES

For an explanation of the characteristics of proximity fuzes, see Chapter 4, paragraph 4-22.

5-22. FUZE WRENCH AND FUZE SETTER

For details on the use of the fuze wrench and fuze setter, see Chapter 4, paragraph 4-23.

5-23. PREPARATION OF AMMUNITION

For an explanation of preparation of ammunition, see Chapter 4, paragraph 4-24.

5-24. CARE AND HANDLING

For proper care and handling of ammunition, see Chapter 4, paragraph 4-25.

CHAPTER 6

4.2-INCH MORTAR, M30

The 4.2-inch mortar, M30, delivers timely, accurate fires to meet the requirements of supported troops. This chapter discusses assigned personnel duties, organization, operation, carriers, and ammunition.

Section I. SQUAD AND SECTION ORGANIZATION AND DUTIES

Each member of the infantry mortar squad has principal duties and responsibilities. (See FM 7-90 for platoon drills.)

6-1. ORGANIZATION

The 4.2-inch mortar section is the basic fire unit for the mortar platoon. If the mortar section is to operate quickly and effectively in accomplishing its mission, mortar squad members must be proficient in individually assigned duties. Correctly applying and performing these duties enables the mortar section to perform as an effective fighting team. The platoon leader commands the platoon and supervises the training of the elements. He uses the chain of command to assist him in effecting his command supervising duties.

6-2. DUTIES

The 4.2-inch mortar squad consists of four men (Figure 6-1). Their firing positions and principal duties are as follows:

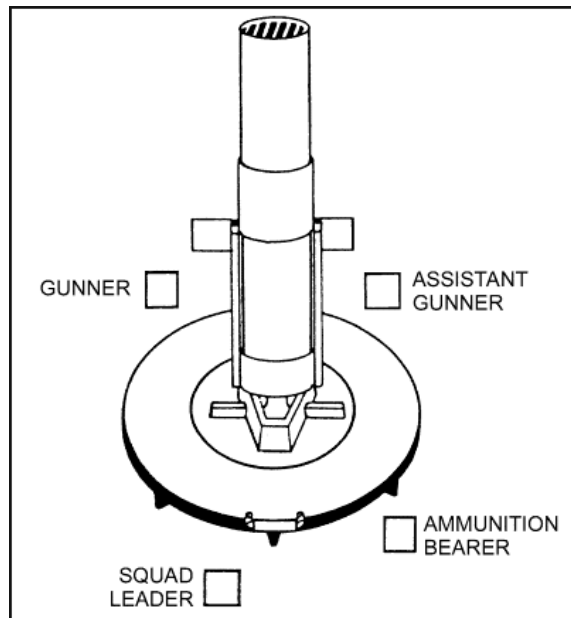

Figure 6-1. Positions of squad members.

- a. The *squad leader* stands behind the mortar where he can command and control his squad. In addition to supervising the emplacement, laying, and firing of the mortar, he supervises all other squad activities.
- b. The *gunner* stands on the left side of the mortar where he can manipulate the sight and elevating gear handle and traversing assembly wheel. He places firing data on the sight and lays the mortar for deflection and elevation. He and the assistant gunner make large deflection shifts by shifting the bridge assembly (or turntable when track mounted).
- c. The *assistant gunner* stands to the right of the mortar, facing the barrel and ready to load. In addition to loading, he assists the gunner in laying the mortar by cross-leveling the sight. He is responsible for swabbing the bore after each 10 rounds have been fired, or after each end of (fire) mission. He assists the gunner in shifting the bridge assembly (or turntable, if track mounted) when making large deflection changes, and shifts the mortar from low range to high range or vice versa when making large elevation changes.
- d. The *ammunition bearer/driver* stands behind the mortar to maintain, prepare, and then pass the ammunition to the assistant gunner for firing. He also places out

the aiming post. If necessary, he is also responsible (along with the squad leader) for the combat readiness of their mortar carrier.

6-3. SECTION DRILL AND SECTION LEADER DUTIES

Section training is the commander's responsibility. His imagination and ingenuity determine the value of this training; therefore, a prescribed sequence of training is not listed. The mortar section is drilled in all aspects of section training under the supervision of the section leader.

a. The section leader is located in the mortar section of the infantry heavy mortar platoon. He is responsible for the actions of the three mortar squads under his control. The duties of the section leader are as follows:

- Supervises the occupation of the firing position.
- Lays the section.
- Checks communications with the FDC and mortar squads.
- Gives section leader's report to the FDC.
- Has the mortar sights calibrated, if time permits.
- Controls the delivery of fires as directed by the FDC.
- Ensures that adequate and balanced stocks of ammunition are on hand and properly stored.
- Supervises the accounting of ammunition to include lot registration and control.
- Ensures that the section is laid on final protective fire data when not otherwise engaged.

b. At intervals, the squad is given the command to refer and realign their aiming posts and to remove misfires from the mortar.

Note: Guidelines for a training program can be found in ARTEP 7-90-MTP and ARTEP 7-90-Drill.

Section II. COMPONENTS

The 4.2-inch mortar, M30 (Figure 6-2), is a rifled, muzzle-loaded weapon with the mission to deliver high-angle, indirect fire. During firing, its components absorb the forces of recoil as a unit. The mortar can be hand carried for short distances when disassembled into five loads.

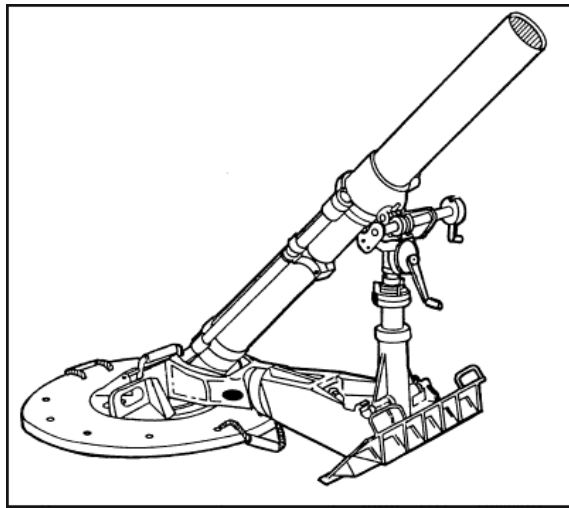

Figure 6-2. 4.2-inch mortar, M30.

6-4. TABULATED DATA

The tabulated data for the 4.2-inch mortar, M30, are as shown in Table 6-1.

WEIGHTS (pounds)		
Mortar complete (welded steel rotator and M53 sight)		672.25
Cannon, M30		156.50
Bridge assembly		169.00
Baseplate assembly		193.00
Standard assembly		59.50
Rotator assembly		57.50
Cast magnesium		89.00
Welded steel		5.25
Sight, M53		
RANGE (M329A2 ammunition) (meters)		
Maximum (approximate)		6,840
Minimum (approximate)		770
ELEVATION (Level ground; flat, even surface) (mils)	LOW RANGE	HIGH RANGE
Maximum	933	1156
Minimum	706	919
Firing elevations	800 or 900	900 or 1065
For each turn of elevating handle (approx)	13	13

SHIFTS (mils)	
Per turn of traversing crank (approximately)	10
On traversing mechanism (right or left from center)	125
Movement of standard assembly and bridge assembly	6400
RATE OF FIRE (M329A2 ammunition)	
The maximum rate of fire is 18 rounds per minute for the first minute and 9 rounds per minute for the next five minutes. This can be followed by a sustained rate of fire of 3 rounds per minute for prolonged periods.	
Note: Locational terms "right," "left," "front," and "rear" regarding the 4.2-inch mortar, M30, and sightunits, M53 and M64 series, apply when viewed in the direction the mortar is firing.	

Table 6-1. Tabulated data for the 4.2-inch, M30.

6-5. MORTAR CANNON, M30

The cannon (also referred to as the barrel) is a rifled tube 60 inches (152.4 centimeters) long with an inside diameter of 106.7 mm (4.2 inches) between lands (Figure 6-3). This rifling consists of 24 lands and 24 grooves of which the first 9 inches (22.86 centimeters), as measured from the base inside the barrel, are straight. The twist increases to the right from zero at this point to one turn in 84 inches (213 centimeters). The tube cap and firing pin are combined in a one-piece casting that screws onto the barrel. The trunnion pins on the cap fit into slots in the cap trunnion sockets in the bridge. These trunnion pins lock the cannon to the bridge assembly or socket assembly (track mounted) during firing. The coupling and sight mount assembly are held in position by two fully enclosed shock absorbers. The cannon is fastened to the standard assembly at this coupling. The sight socket and sight mount assembly are attached to this coupling.

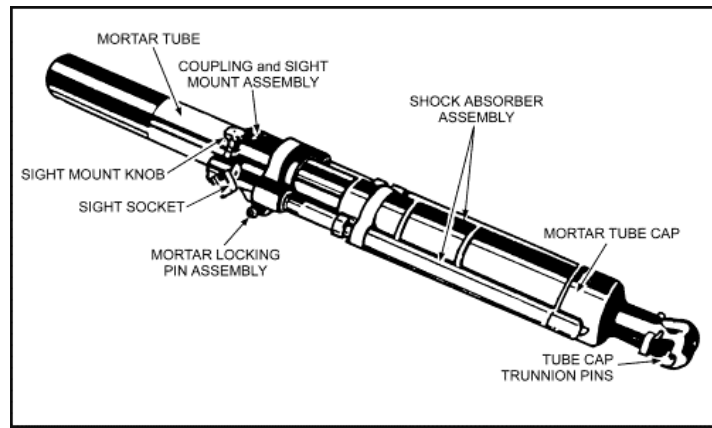

Figure 6-3. Cannon, M30.

Note: Although the terms cannon, tube, and barrel indicate an assembly in which ammunition is fired and which controls the initial direction of a projectile, in mortar terminology barrel is the most commonly used term. The M30 mortar cannon is the complete assembly consisting of the mortar tube, tube cap, firing pin, tube cap trunnion pins, coupling and sight mount assembly, sight socket, and shock absorbers. In order to facilitate understanding and increase learning, the term barrel is used throughout this chapter in all references pertaining to the mortar cannon (the complete cannon assembly).

6-6. MORTAR MOUNT, M24A1

The mortar mount consists of the standard assembly, bridge assembly, rotator assembly, and baseplate.

a. **Standard Assembly.** The standard assembly consisting of the elevating, traversing, and recoil mechanisms connects the cannon and bridge assembly or standard support on the turntable (Figure 6-4). It is held to the bridge assembly by two trunnions that fit into sockets on the bridge spade or standard support assembly. The connection for the mortar locking pin assembly on the standard assembly is fastened to the coupling and sight mount assembly by the mortar locking pin assembly. Both the elevating and traversing screws are enclosed.

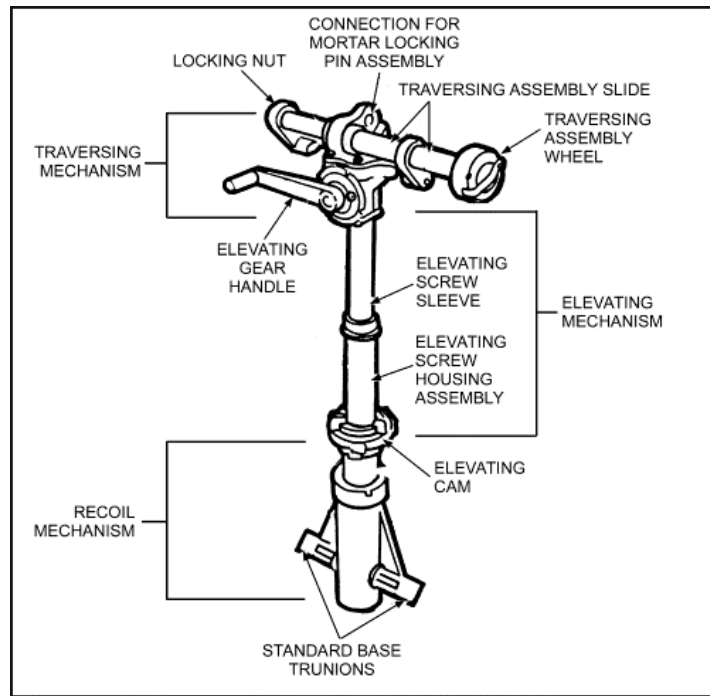

Figure 6-4. Standard assembly with elevating, traversing, and recoil mechanisms.

- (1) The elevating gear handle, located in front of the mortar at the top of the standard assembly, is used to elevate or depress the mortar throughout the low or high ranges of elevation. An elevating screw housing assembly in the lower part of the standard assembly makes possible the two ranges of elevation. The desired high or low range is selected by using the elevating mechanism cam located just above the recoil mechanism on the standard assembly.
- (2) The elevating mechanism cam (Figure 6-4) locks the elevating screw housing assembly in its low or high range position. This assembly cannot be locked in any intermediate position.
- (3) The traversing mechanism (Figure 6-4) consists of an enclosed screw and bearing located at the top of the standard assembly. It is operated by turning the traversing crank on the left side of the mechanism.

(4) The recoil mechanism consists of a series of springs mounted in the lower section of the standard assembly. They are designed to ease the downward shock of firing and to return the mechanism to the prefiring position.

b. **Bridge Assembly.** The bridge assembly (Figure 6-5) consists of two pieces joined by a swivel joint.

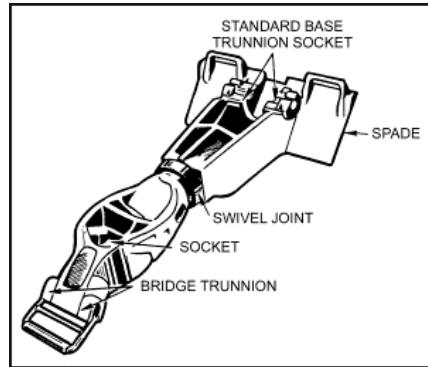

Figure 6-5. Bridge assembly.

(1) The socket end is designed to receive the tube cap. It has a closed slot in the left side of the socket and an open slot in the right side. These slots receive the tube cap trunnions. Two bridge trunnions behind the socket fit into the bridge trunnion socket on the rotator.

(2) The spade at the front of the bridge assembly facilitates the digging action of the bridge assembly during firing. Two steel trunnion sockets to the rear of the spade hold the standard assembly.

c. **Rotator Assembly.** The rotator assembly (Figure 6-6) is about 20 inches (50.8 centimeters) in diameter. The bridge trunnion sockets are on the upper side of the rotator assembly. A projection on the underside fits into a recess in the baseplate assembly and contains the rotator slide lock. The rotator slide lock is actuated by the insertion of the bridge trunnions into their sockets, which depresses the expansion pin and securely locks the rotator and baseplate assemblies together. This projection also forms the pivot around which the rotator assembly rotates on the baseplate assembly.

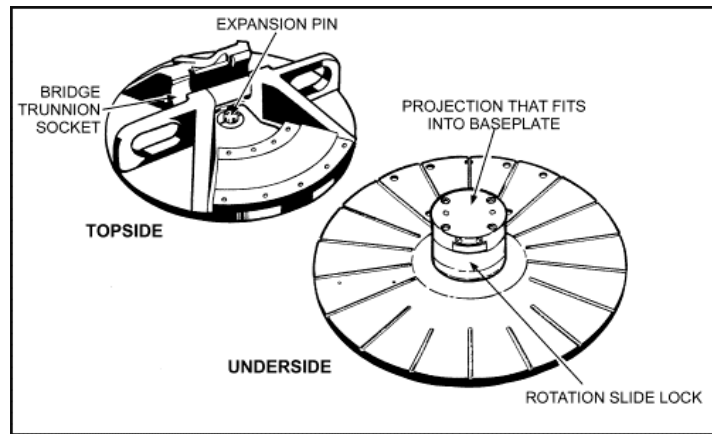

Figure 6-6. Rotator assembly.

d. **Baseplate and Rotator Assemblies.** The baseplate assembly (Figure 6-7) is about 38 inches (96.52 centimeters) in diameter. A recess in the center receives the bottom insert of the rotator assembly. The lower surface contains six ribs to increase the area in contact with the ground. Each rib has a depth of about 6 1/2 inches (16.51 centimeters).

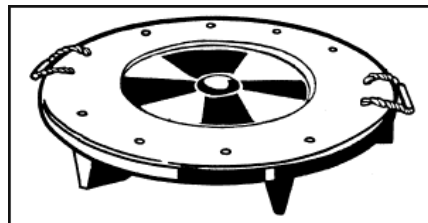

Figure 6-7. Baseplate.

WARNING

Two carrying handles are provided but not recommended for use since possible bodily injury may result.

Section III. OPERATION OF GROUND-MOUNTED MORTAR

This section contains information on how to prepare the 4.2-inch mortar, M30, for firing; how to conduct safety checks; and how to perform misfire procedures. The battalion heavy mortar platoon may be employed as a complete platoon of six mortar squads or it may be split and employed as two firing sections.

6-7. MOUNTING OF THE MORTAR

The purpose of squad drill is to develop teamwork within the mortar squad and to cross-train each mortar squad member.

- a. The squad leader picks up the sight case and two aiming posts, and moves to the exact position where the mortar is to be mounted. He places the sight case and aiming posts to the left front of the mortar position. He then points to the exact spot where the mortar is to be mounted and indicates the initial direction of fire. He commands, ACTION.
- b. The gunner on the left side and assistant gunner on the right secure the baseplate and rotator assemblies (carried as one unit). They place it in the position indicated by the squad leader. The assistant gunner positions the rotator assembly in the desired direction of fire.
- c. The gunner ensures that the sandbags or ammunition boxes are in position so that the bridge assembly rests on them. (Sandbags or ammunition boxes are used only for gunner examinations, crew drills, and demonstrations.) When the mortar is fired, the baseplate assembly is dug in to be firmly placed on the ground. This also ensures that the bridge assembly is level with the baseplate assembly.

Note: Squad members move to the mortar position from the left side and return on the right side when assembling and disassembling the cannon.

- d. The squad leader and ammunition bearer secure the bridge assembly; the ammunition bearer carries the socket end and seats the trunnions of the bridge assembly into the trunnion socket of the rotator. The squad leader elevates the spade end of the bridge, thus allowing the trunnions to slide into place (Figure 6-8). The squad leader places the spade end down on the sandbags or ammunition box and positions it so it is level in the horizontal plane.

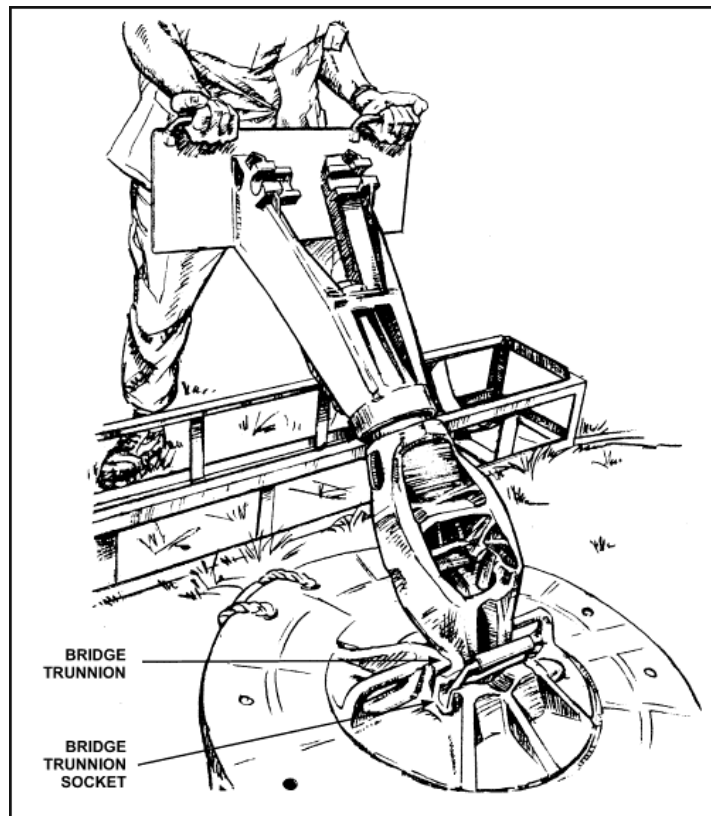

Figure 6-8. Rotator and bridge assemblies installed.

e. The assistant gunner picks up the standard assembly with his right hand on the traversing assembly wheel and his left hand on the locking lug. He places the standard base trunnions behind the standard base bearings, tilts the top of the standard forward, and pulls the standard toward himself. The standard base trunnions fall into the standard base trunnion sockets (Figure 6-9). The assistant gunner raises the standard assembly to the vertical position, turns the traversing assembly slide 180 degrees, centers the traversing assembly slide, and elevates the elevating mechanism 15 turns.

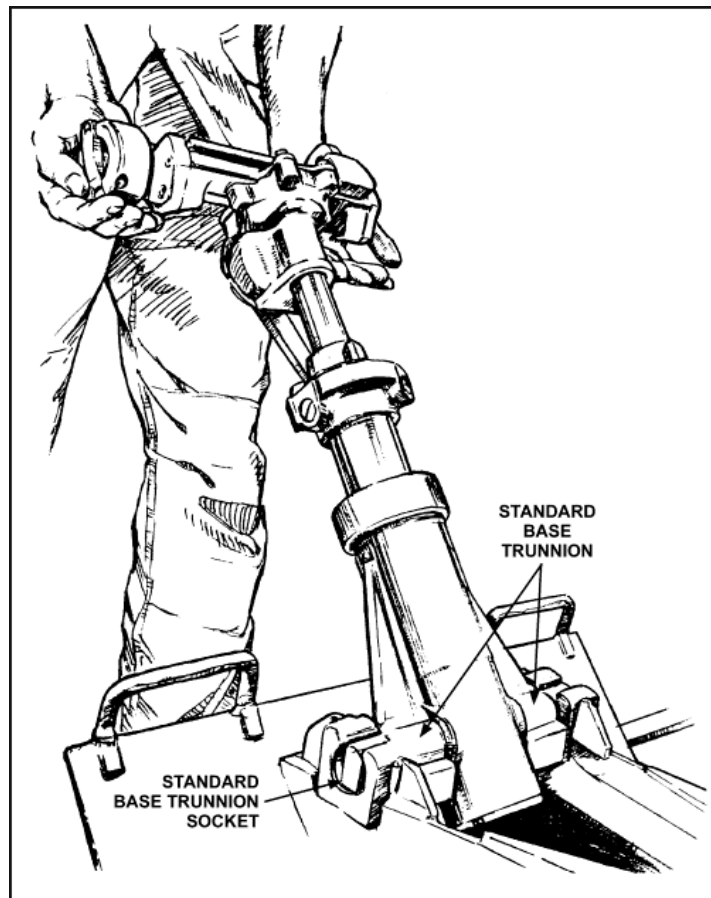

Figure 6-9. Installation of standard assembly.

f. The squad leader and ammunition bearer secure the barrel (the squad leader carrying the muzzle end) and bring it up on the left side. The squad leader inserts the left tube cap trunnion pin into its recess in the left side of the bridge socket (Figure 6-10). The ammunition bearer then cants the barrel to the right, allowing the right tube cap trunnion pin to slide down an elongated slot to its socket, and places the barrel on the right shoulder of the assistant gunner.

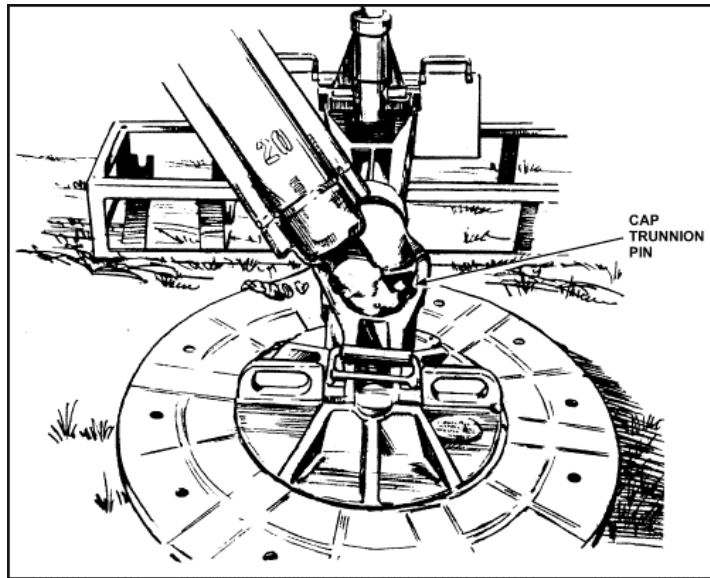
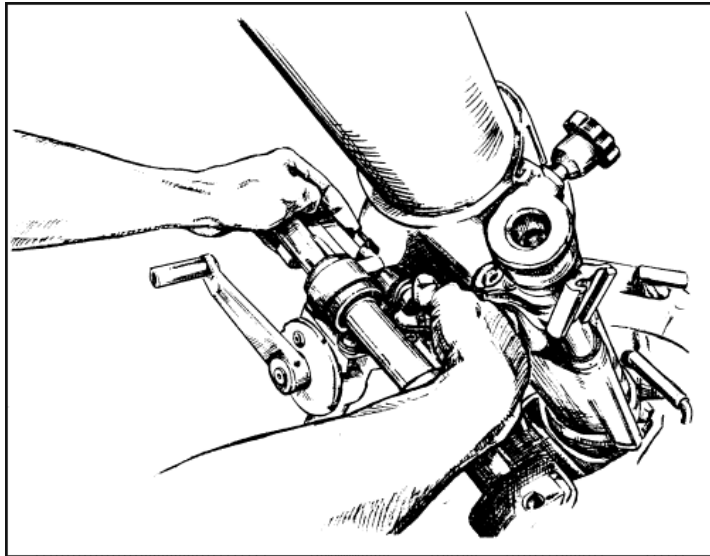

Figure 6-10. Barrel positioned into the bridge assembly.

g. The ammunition bearer withdraws the mortar locking pin assembly. The assistant gunner lowers the barrel until it fits into position on the locking lug of the slide assembly. He inserts the mortar locking pin and turns it 180 degrees in either direction to lock the barrel to the standard assembly (Figure 6-11). He removes the muzzle cover.



6-11. Barrel locked to the standard assembly.

h. The gunner (who has placed a 3200-mil deflection on the deflection scale of the M53 sightunit and 900 mils elevation) now places the sightunit on the mortar (Figure 6-12). He then ensures that the unit is properly seated in the sight socket to prevent errors or damage to the sight. Aided by the assistant gunner, he levels the mortar and announces, "Up."

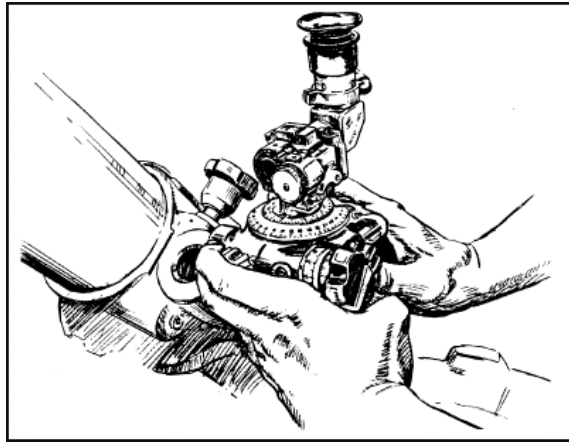

Figure 6-12. Sightunit installed.

- i. The squad leader verifies the proper mounting of the mortar and notifies the section leader that this mortar is mounted by announcing, "Number two (or appropriate mortar number) up."

6-8. SAFETY CHECKS BEFORE FIRING

The following safety checks must be enforced before firing the mortar.

- a. The gunner ensures that--
 - (1) Tube cap trunnion pins are properly inserted into the bridge socket.
 - (2) Bridge trunnions are properly inserted into the bridge trunnion socket of the rotator assembly.
 - (3) There is clearance between the bridge assembly and the rotator pad.
 - (4) The bridge spade has contact with the ground (sandbags should not be used to support the bridge spade during firing) and that any noticeable cant has been removed from the weapon.
 - (5) Standard base trunnions are properly seated into the sockets of the bridge.
 - (6) Elevating assembly cam is in the locked position.

(7) Standard assembly is properly coupled and locked to the barrel by the mortar locking pin assembly (turned 180 degrees in either direction).

(8) The mortar has mask and overhead clearance by placing his head near the tube cap and sighting along the barrel for any obstructions in the path of the round. The gunner checks the mortar at its maximum and minimum firing elevations.

b. The assistant gunner ensures that the bore is clean and swabs the bore dry. During firing, he swabs the bore after every 10 rounds fired or at the completion of each fire mission.

c. The ammunition bearer ensures that--

(1) Ammunition is clean and that all rust-preventive compound is removed from the fuze, body, cartridge container, and flash holes.

(2) Fuzes are screwed tightly against the shell body. If fuzes are loose, the ammunition bearer tightens them with the correct fuze wrench.

(3) Correct charge is placed on each cartridge, and the propelling charges are positioned properly.

(4) Ignition cartridge is present and the striker nut is tight.

Note: See TM 9-1015-215-12 for more information.

WARNING

The squad leader supervises the enforcement of safety procedures to prevent injury to personnel or damage to equipment.

6-9. SMALL DEFLECTION CHANGE

With the mortar mounted and sight installed, the sight is laid on the two aiming posts (placed out 50 to 100 meters from the mortar) on a referred deflection of 2800 mils and elevation of 900 mils. The mortar is within two turns of center of traverse, and the vertical cross line of the sight is on the left edge of the aiming post.

a. The gunner is given a deflection change in a fire command between 50 to 75 mils inclusive. As soon as the deflection change is announced, the gunner places the announced deflection on the sightunit and traverses back onto the aiming post. The sight is cross-leveled by the assistant gunner.

- b. After the gunner has announced, "Up," the mortar should be checked by the squad leader to determine if the exercise was performed correctly.

6-10. LARGE DEFLECTION AND ELEVATION CHANGES

With the mortar mounted and sight installed, the sight is laid on the two aiming posts (placed out 50 and 100 meters from the mortar) on a referred deflection of 2800 mils and an elevation of 900 mils (low range).

- a. The gunner is given a deflection and elevation change in a fire command. The gunner must shift the mortar between 200 and 300 mils inclusive and make an elevation change that causes him to elevate or depress the barrel. As soon as the deflection and elevation changes are announced, the gunner places the announced deflection on the sightunit. The assistant gunner unlocks the elevating mechanism cam and places the mortar in high or low range, whichever is appropriate.
- b. The gunner elevates or depresses the mortar until the bubble floats freely. The assistant gunner picks up the spade end of the bridge. Looking through the sight, the gunner places his left hand on the assistant gunner's shoulder, pulling to the left or pushing to the right, until the vertical cross line is on or near the correct sight picture.
- c. The assistant gunner moves back into position and cross-levels the sightunit. The mortar should be within two turns of center of traverse when the exercise is completed.

6-11. LOADING AND FIRING OF M329A2 ROUND

On receiving a fire command from the section leader, the gunner repeats each element. He places the firing data on the sight and, aided by the assistant gunner, lays the mortar. The ammunition bearer repeats the charge element when announced by the gunner and prepares the round with that charge. (If a fuze setting is announced, the ammunition bearer also repeats the setting and places it on the fuze.) He completes his preparation of the round to include the safety checks. The squad leader spot-checks the data on the sight and the lay of the mortar. He then commands, FIRE. The crew fires the mortar as follows:

- a. If firing from a ground mount, the gunner removes the sightunit, being careful not to disturb the lay of the mortar. He continues to remove the sightunit until the baseplate assembly is settled and there is no danger of the sightunit becoming damaged from the recoil of the mortar.
- b. The first ammunition bearer passes a round to the assistant gunner. He holds the round with the palms of both hands up near each end of the round so that the fuze is pointing in the general direction of the mortar.

c. The assistant gunner takes the round from the first ammunition bearer with his right hand palm up and his left hand palm down. The assistant gunner grasps the body of the round near the center and guides it into the barrel as far as the rotating band. The tail end (tail assembly, projectile base, and rubber obturator) of the cartridge is inserted into the muzzle. The assistant gunner rotates the cartridge clockwise until the pre-engraved band (M329A2 cartridge) engages the lands and grooves (rifling) in the barrel. The assistant gunner lowers the cartridge into the barrel (to the "4.2-INCH-M" marking).

d. While lowering the cartridge, the assistant gunner rotates it clockwise, ensuring the cartridge follows the twist of the rifling. He cuts both hands sharply away and down along the barrel. At the same time, he pivots to the left and bends toward the first ammunition bearer, extending his hands to receive the next round. The assistant gunner must not disturb the lay of the mortar as he loads the round (the round can bind when the base end enters the barrel). This can cause considerable dispersion in the target area and can create unsafe conditions because of erratic fire.

6-12. MALFUNCTIONS

See Chapter 3, paragraph 3-14 for a detailed discussion of malfunctions.

6-13. REMOVAL OF A MISFIRE

Misfire procedures are described herein.

a. During firing, the first crew member who notices a misfire has occurred announces, "Misfire."

(1) When a misfire is announced, the entire squad stays with the mortar. If the round did not slide down the barrel and the projectile body can be grasped, the gunner removes the stuck round. The M329A2 is freed by rotating it in a clockwise direction.

WARNING

During peacetime live -fire training, all personnel, except the gunner, move at least 50 meters to the rear of the mortar or carrier.

(2) If the round slid completely or partly down the barrel (not visible or only the fuze is visible), the gunner stands behind the barrel and kicks it sharply several times with the heel of his boot.

WARNING

During peacetime live-fire training, if the round does not fire, the gunner joins the crew and waits one minute to avoid personal injury due to a cookoff. After waiting one minute, the gunner then returns to the mortar and tests the barrel for heat. When the barrel is cool enough to handle, the gunner signals for the rest of the crew to come forward.

(3) If kicking the barrel does not dislodge the round, the gunner waits until the barrel is cool enough to handle with bare hands (he checks for heat with his fingertips from the muzzle to base plug). The barrel may be cooled with water or snow. If the barrel is not cool enough to handle, the gunner waits one minute to avoid an accident from a hangfire or the ignition cartridge and possible damage to the barrel from rapid quenching during cooling.

Note: If temperature is above 32 degrees, a minimum of three quarts of water is used. If temperature is below 32 degrees, a solution of two quarts of water and two quarts of antifreeze is used.

WARNING

The water or water and antifreeze cushions the impact of the round onto the firing pin should a stuck round dislodge during the removal operation. This prevents the primer from functioning. The round will not be refired.

(4) The gunner lifts the container of water or water and antifreeze from behind the barrel and pours the entire amount slowly into the barrel. If only water is used, a 2-minute wait is allowed to let the water flow past the cartridge to the bottom of the barrel. If water and antifreeze is used, a 30-minute wait is allowed to let the water flow past the cartridge to the bottom of the barrel.

WARNING

A stuck round could dislodge and fire as the water or water and antifreeze is being poured into the barrel. All personnel

ramp of the carrier is closed to protect the gunner. At no time will any part of the gunner's hands or body be placed in front of the muzzle of the barrel.

Note: The gunner moves back with other crew members when water and antifreeze is used to remove the cartridge from the ground-mounted mortar.

WARNING

Keep body and head away from front of the mortar.

b. Removal procedures are described herein.

- (1) The gunner locks the firing data on the sight, removes it, and places it in a safe place.
- (2) The gunner signals the squad to come forward and removes the sightunit.
- (3) The assistant gunner cranks the mortar barrel to its highest position in low range or to its lowest position in high range and backs off two turns.
- (4) The gunner traverses the mortar to the extreme left.
- (5) The gunner and assistant gunner tilt the mortar barrel, bridge assembly, and standard assembly to the left, allowing the cap assembly trunnion pin to slide up in the slots.
- (6) The squad leader and ammunition bearer, without getting behind the mortar barrel, should carefully lift the barrel out of the bridge trunnion socket and rest it on the bridge assembly. The gunner and assistant gunner return the bridge assembly to its original position.
- (7) The assistant gunner places his hands around the muzzle, making certain that no part of his hands extend over the muzzle.
- (8) The gunner supports the barrel in front of the standard assembly (Figure 6-13) with his right arm around the barrel.



Figure 6-13. Gunner supporting the barrel.

WARNING

Never lower the base of the barrel below a horizontal position until the cartridge has been removed.

(9) The squad leader and ammunition bearer carefully lift the base end of the barrel without getting behind it, and slowly raise it to the horizontal position, while the cartridge moves slowly toward the muzzle.

(10) The assistant gunner extends the thumbs of both hands over the muzzle as the barrel reaches the horizontal position. The squad leader and ammunition bearer continue to raise the rear of the barrel.

WARNING

When removing the cartridge, the assistant gunner does not touch the striker since it may be armed.

(11) The assistant gunner stops the cartridge with his thumbs, removes it, and places it a safe distance from the mortar position as prescribed by local policy (Figure 6-14). Explosive ordnance disposal personnel are notified.



Figure 6-14. Assistant gunner removing misfire.

WARNING

Under no circumstances will an attempt be made to refire the round.

(12) The gunner and ammunition bearer shake the barrel to remove any debris. The barrel is then placed back into the firing position, and the ammunition bearer swabs it.

(13) If another misfire occurs when firing is resumed, the cartridge is removed and the barrel is checked for damage or fouled firing pin.

c. If the cartridge cannot be removed from the barrel (ground-mounted), the crewmembers must follow these procedures:

(1) The gun crew returns the barrel to its horizontal position. The gunner pushes in, rotates, and disengages the mortar locking pin assembly, while supporting the standard assembly. The squad leader, assistant gunner, and ammunition bearer support the barrel, keeping it in the horizontal position.

(2) The squad leader, assistant gunner, and ammunition bearer remove the barrel from the standard assembly. Keeping the barrel horizontal, they place it on the ground in the direction of fire, a safe distance from the mortar. Explosive ordnance disposal personnel are notified.

Note: For more information on the disposition of misfires, see AR 385-63, TM 9-1300-206, or TM 9-1015-215-10.

6-14. DISMOUNTING OF THE MORTAR

To dismount the mortar, the squad leader commands, OUT OF ACTION. Then, the squad follows these procedures:

a. The second ammunition bearer retrieves the aiming posts. The gunner removes the sight, places an elevation of 800 mils and a deflection of 3800 mils on the M53 sightunit and places it in the case.

b. The assistant gunner replaces the muzzle cover.

c. If the mortar barrel is in high range, the assistant gunner places his shoulder under the barrel, unlocks the elevating cam, and gently lowers the barrel to the low range.

d. The assistant gunner disengages the mortar locking pin assembly and raises the barrel with his right shoulder to disengage the mortar from the standard assembly. The ammunition bearer removes the barrel from the assistant gunner's shoulder, then reinserts the mortar locking pin and cants the barrel to the left to disengage the trunnion pins. The squad grasps the base end of the barrel. Both mortarmen (squad leader and ammunition bearer) lift the barrel out of the socket.

e. The assistant gunner lowers the elevating mechanism, positions the connection for the mortar locking pin assembly to the extreme right, and folds the traversing crank to its inoperative position. He then rotates the standard assembly away from the baseplate assembly and lifts up, disengaging the standard base trunnions.

f. The ammunition bearer moves to the spade end of the bridge and elevates it. The squad leader disengages the bridge trunnions from the rotator assembly.

g. As the bridge spade is raised, the gunner removes the sandbags. The gunner and assistant gunner remove the baseplate and rotator assemblies (assembled).

h. The squad leader picks up the aiming posts and sightunit. At the command MARCH ORDER, the squad places the mortar, equipment, and ammunition in the squad vehicle and trailer.

Section IV. MORTAR CARRIERS, M106, M106A1, AND M106A2

This section is a guide for training mortar units equipped with the M106, M106A1, and M106A2 mortar carriers for mounting the 4.2-inch mortar, M30. The procedures and techniques for a mounted mortar are different from ground-mounted.

6-15. DESCRIPTION

The M106 carrier (Figure 6-15) is the M113 armored personnel carrier modified to carry the 4.2-inch mortar, M30, on a specially designed mount (Figure 6-16). It is an armored, full-tracked, self-propelled vehicle that can swim streams and small bodies of water. A caliber .50 machine gun is mounted on the cupola for the vehicle commander's use.

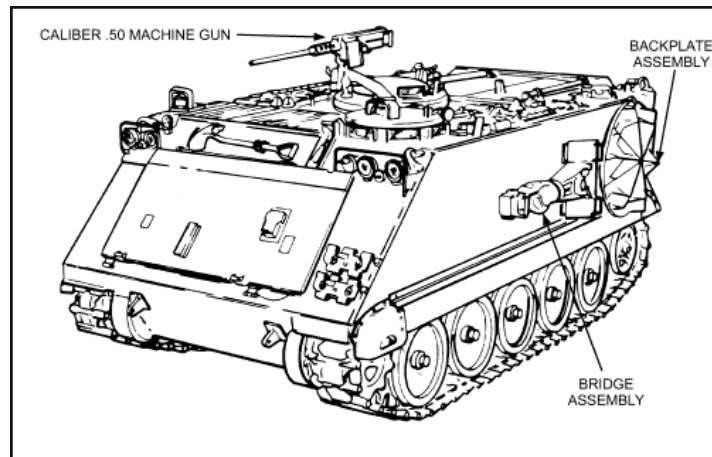

Figure 6-15. Mortar carrier, M106, left front view (caliber .50 machine gun mounted on cupola).

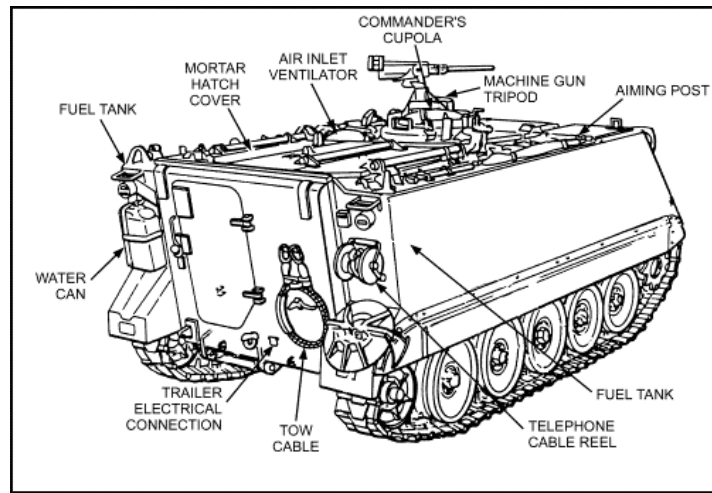

Figure 6-16. Mortar carrier, M106, top rear view.

a. To fire the 4.2-inch mortar from the carrier, the top plating to the rear of the carrier has a mortar-hatch cover, which is hinged and folds to both sides. The carrier provides limited armor protection for the squad during maneuver. In combat, the mortar is fired with the ramp closed and locked. During firing exercises in training, the mortar may be fired with the ramp open for visual inspection by safety personnel.

b. The mortar and its components can be removed from the carrier for ground-mounted firing. The baseplate, bridge, and rotator assemblies of the ground mount are stowed outside the carrier.

6-16. TABULATED DATA

The tabulated data of the M106 carrier are as shown in Table 6-2 follows:

GENERAL INFORMATION	M106	M106A1	M106A2
Crew capacity	5	5	6
Weight (pounds):			
Combat load	25,700	26,137	26,876
Airdrop	19,380	19,850	20,589
Ground pressure (psi) (combat weight)	8.2	8.3	8.6
Armament	4.2-inch mortar, M30; .50-caliber machine gun	4.2-inch mortar, M30; .50-caliber machine gun	4.2-inch mortar, M30; .50-caliber machine gun

AMMUNITION STOWAGE			
Mortar, 4.2-inch, M30	93 rounds	88 rounds	88 rounds
.50 Caliber	600 rounds	600 rounds	600 rounds
7.62-mm	720 rounds	720 rounds	720 rounds
Fuzes	54 fuzes	54 fuzes	54 fuzes
MEASUREMENTS (inches)			
Overall length	194	194	194
Maximum width	113	113	105 3/4
Maximum height	87	98	87 1/2
Ground clearance	16	16	17 1/8
FUEL CAPACITY (gallons)	85 gasoline	95 diesel	95 diesel
PERFORMANCE			
Speed (mph):			
Land	40	41.5	40
Water	3.5	3.5	3.6
Grade ability (percent):			
Forward slope	60	60	60
Slide slope	30	30	30
Vertical obstacle (inches)	24	24	24
Trench crossing (inches)	66	66	66
Turning radius (feet):			
Differential steer	22.8	22.8	22.8
Pivot steer	12.8	12.8	12.8
Cruising range (miles)	185	295	300
Fording capability	Unlimited	Unlimited	Unlimited
(Do not exceed gross weight rating)			
Bilge pump output (gpm)	44	44	44
MORTAR CAPABILITIES MOUNTED ON TURNTABLE	M106	M106A1	M106A2
Traversing limits (mils):			
Right of center with connection for mortar locking pin assembly		825	800
Left of center with connection for mortar locking pin assembly		775	800
Total traverse capability from extreme left to extreme right (mils)		1600	1600
Elevation limits (level track) maximum (mils)		1124	1600
Elevation limits (level track) minimum (mils)		740	1600

Table 6-2. Tabulated data for the M106 carrier.

Section V. OPERATION OF CARRIER-MOUNTED MORTAR

The mortar section is the basic fire unit for the mortar platoon. When a position is occupied, the mortars are emplaced 40 meters apart, making a section front (distance between flank mortars) of about 80 meters. The mortars are numbered 1, 2, and 3 from right to left when facing in the direction of fire, without regard to the permanent squad

numbers within the section--for example, the first squad is not necessarily mortar No. 1. The squads of the heavy mortar platoon in the mechanized infantry battalion and tank battalion, whose prime mover is the mortar carrier (M106, M106A1, or M106A2), consist of four men: the squad leader, gunner, assistant gunner, and ammunition bearer/driver (Figure 6-17). The differences in the procedures from a ground-mounted mortar squad are also discussed herein.

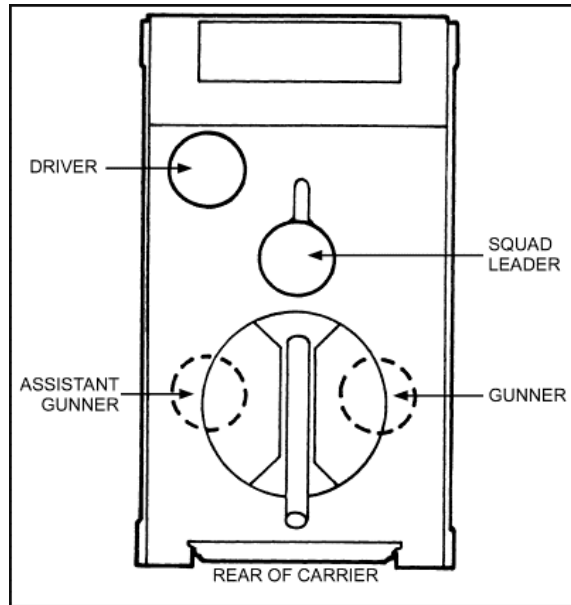

Figure 6-17.

6-17. MORTAR AND VEHICULAR MOUNT

The mortar is carried while attached to its vehicular mount. A mount tie-down strap is provided to tie the mortar (when it is depressed to its lowest elevation) and the standard base trunnion bearing support (when lowered to its lowest position) (Figure 6-18). The trunnion detent pins at the base assembly are placed in their innermost position. The vehicular mount is locked in position by the turntable traverse lock. Securing the mortar for distant moves is required to prevent damage to the standard assembly recoil and counterrecoil mechanism, and possible injury to personnel. The mortar is provided with a sight extension arm assembly, which is received by the socket of the coupling and sight mount assembly. The gunner uses the sight extension arm to sight on his aiming point above the hull of vehicle. The sight extension must be removed before movement to prevent wear on the sight mount coupling gears. The vehicular mount supports the mortar

and aids in securing the mortar for traveling. The mount consists of the components described in the following paragraphs.

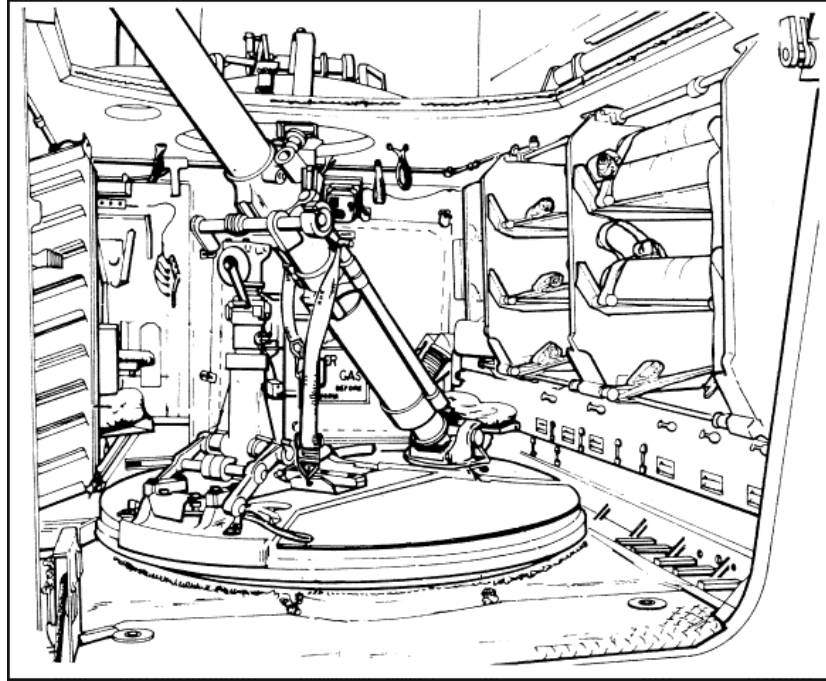

Figure 6-18. Vehicular mount.

a. **Mortar Standard Assembly Support.** The standard assembly support located at the front of the mortar turntable retains the mortar barrel in the firing position. The lock consists of spring-loaded release levers, a catch, and a spring-loaded guard. The catch automatically latches when the mortar and standard assembly are raised to the firing position. To release the catch, raise the guard, step on the release, and lower the mortar barrel and standard assembly.

b. **Traverse Locking Handle.** The traverse locking handle, located in the center of the mortar turntable, locks the turntable to the indexing ring during mortar firing. To engage the lock, push the handle down until the latch automatically engages. To release the lock, raise the latch and pull up the locking handle.

c. **Traversing Straps.** These two straps are used to help traverse the turntable when it must be forced into position.

d. **Mortar Barrel Socket Assembly.** The socket assembly, located at the rear of the mortar turntable, receives and retains the barrel with detent pins—one on each side of the socket. The pins have two detent positions. To insert the barrel, the pins must be pulled to their outermost detent position. To retain the barrel, the pins are pushed to their innermost detent positions.

e. **Mortar Tie-Down Strap.** The mortar tie-down strap is located on the mortar turntable. When not in use, the strap is stowed in the mortar equipment bag. The strap consists of a ratchet buckle with a hook on the lower and upper ends, with a D-ring attached in the center section. The strap is used to secure the mortar during travel. To install the strap, the ratchet end is hooked into the eye on the turntable, the upper end is wrapped around the barrel between the coupling and sight mount assembly, and the hook is fastened to the D-ring. The ratchet handle is operated up and down until the strap is tight. To loosen, the handle is opened all the way, the release latch is depressed, and the tie-down strap is pulled on.

f. **Recoil Stop Clamp.** The recoil stop clamp is a hinged collar installed on the standard assembly during on-vehicle mortar firing. This clamp prevents the barrel from being accidentally depressed beyond safe limits (Figure 6-19).

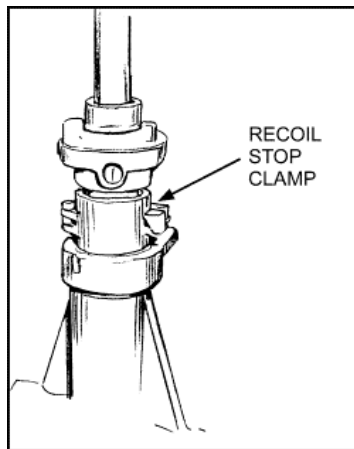

Figure 6-19. Recoil stop clamp.

6-18. MAINTENANCE

Care and cleaning of the mortar, instruments, and equipment are the duty and responsibility of the mortar squad. Care and cleaning of the carrier-mounted mortar are the same as for the ground-mounted mortar. All maintenance records for the mortar and carrier are kept IAW the instructions outlined in TM 38-750-1.

Note: See TM 9-1015-215-20&P for cleaning and lubricating procedures for the 4.2-inch mortar, M30, and the mount, M24A1. For maintenance procedures for the M106, M106A1, and M106A2 carriers, see TM 9-2300-257-10.

6-19. PLACEMENT OF MORTAR INTO FIRING POSITION ON CARRIER

This exercise should begin with the mortar and crew mounted in the carrier (Figure 6-20). The purpose of this exercise is to get the mortar into a firing position to be reciprocally laid, or to engage a target using the direct lay method. The driver leaves the engine running. The intercom between the driver and squad leader is maintained so that the squad leader can direct the driver to move the carrier for the first deflection reading in reciprocal laying. To mount the mortar in the firing position, the squad leader gives the preparatory command PREPARE FOR ACTION, and the mortar squad takes the following actions.

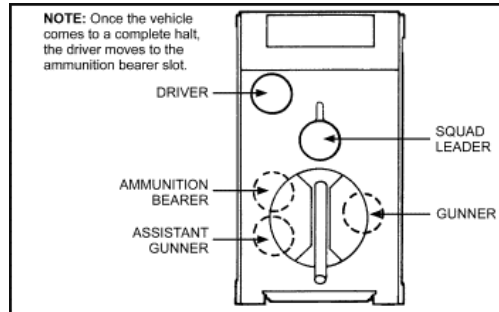

Figure 6-20. Mounted firing posts.

- a. The gunner moves to the center hatch cover chain and grasps the chain. The assistant gunner moves the left mortar hatch cover chain and grasps the chain. The ammunition bearer picks up the sight unit case. When the squad is ready, the squad leader commands ACTION.
- b. On the command ACTION, the gunner and assistant gunner unlock, fold, and lock the hatches. The gunner then unlocks, folds, and locks the right hatch cover into its fully open position.
- c. After the assistant gunner has locked the left hatch, he picks up the sight extension and passes it to the gunner. The gunner places the sight extension on the mortar and adjusts it to his height.

- d. The gunner removes the sightunit from its case, places a 3200-mil deflection and 900-mil elevation on the sight, and places it into the sight socket of the extension.
- e. The assistant gunner releases the tie-down strap ratchet and removes the strap. He then moves to the front of the mortar, places his right shoulder under the mortar, and pushes up until the standard support locks in the raised position. He then elevates the mortar about 15 turns.
- f. The assistant gunner removes the muzzle cover. The gunner and assistant gunner cross-level the mortar and level it for elevation. The ammunition bearer ensures that the detent pins are in their innermost detent position.
- g. The gunner then announces, "Up," and the squad leader signals up to the instrument operator. At this time, the crew should be at the firing post.
- h. The squad is now ready to reciprocal lay or to engage a target by the direct lay method.

6-20. LAYING FOR DEFLECTION AND ELEVATION

This procedure demands coordination and numerous exercises. The turntable must be properly adjusted and lubricated. The squad should know that the traversing turntable straps are used only when the turntable must be forced into position. The connection for the mortar locking pin assembly normally is within two turns of center after properly being laid. Two and one half turns may exist because of the 50-mil interval between the teeth of the turntable traversing ring. This procedure is the same as for the ground-mounted mortar with the following exceptions.

a. Large Deflection Shifts to the Left.

- (1) When a deflection greater than 75 mils is announced in the fire command, the assistant gunner prepares the turntable to be traversed before firing the round.
- (2) As soon as the deflection is announced, the gunner immediately indexes it on the sight (Figure 6-21). He ensures that the mortar is within two turns of center of traverse.

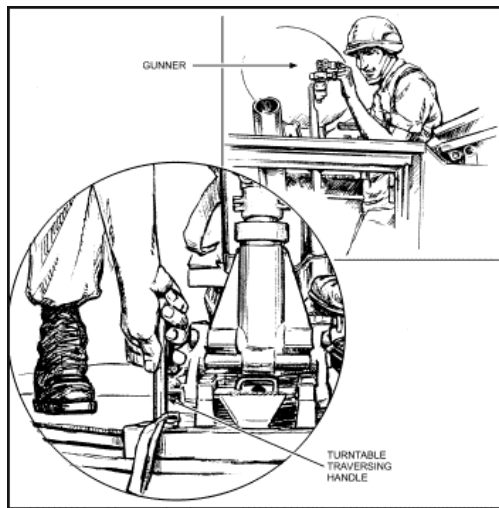

Figure 6-21. Gunner indexing the sight and assistant gunner unlocking the turntable traversing handle.

(3) The assistant gunner pushes down on the turntable traversing handle latch with his left foot. He then raises the handle to the unlocked position and assumes the following position: right foot on the standard support, left foot on the mortar tube socket assembly, right and left hands on the rim of the mortar hatch cover, and body braced on the fuze rack (Figure 6-22).



Figure 6-22. Positions for traversing the turntable.

(4) The gunner assumes the following position: right foot near or on the mortar tube socket assembly, left foot off the turntable, right hand on top of the coupling and sight mount assembly, and left hand on the traversing crank. At the same time, he looks through the telescope of the M53- or M64-series sightunit (Figure 6-22).

(5) The gunner commands PUSH. At this time the assistant gunner pushes the turntable with his right foot; and the gunner pushes with his right foot and pulls with his right hand.

(6) When the gunner has the approximately correct sight picture, he commands HOLD. Upon confirming this sight picture, he commands LOCK.

(7) The assistant gunner locks the traversing lock handle with his right hand (Figure 6-23) or right foot. (The gunner does not attempt to finalize his sight picture before the assistant gunner locks the turntable.)

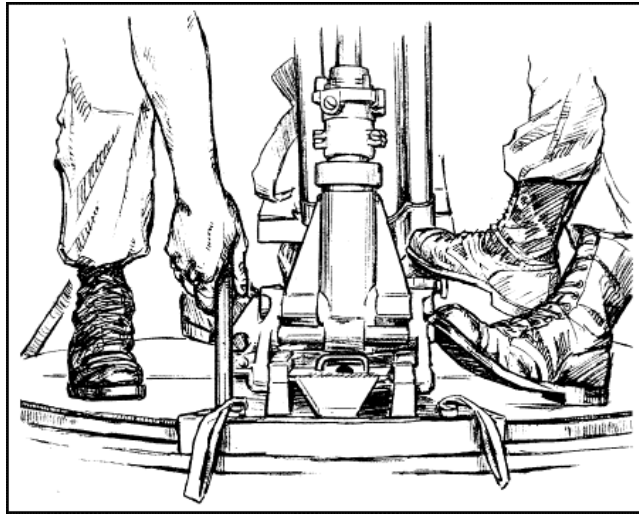

Figure 6-23. Assistant gunner locking the turntable traversing handle.

(8) The gunner and assistant gunner continue to lay the mortar for deflection and elevation using the operating mechanism on the mortar.

(9) When the mortar is correctly laid, the gunner announces, "Up," or commands FIRE.

b. Large Deflection Shifts to the Right. This exercise is the same as large deflection shifts to the left with the following exceptions:

(1) The gunner reverses the position of his feet on the turntable. His right foot is off the turntable and his left foot is on or near the standard support.

(2) When the turntable has been unlocked, the gunner commands PULL.

(3) The gunner and assistant gunner push the turntable with their left feet.

6-21. REMOVAL OF A MISFIRE (CARRIER-MOUNTED)

During firing, the first crew member who notices a misfire has occurred announces, "Misfire."

a. Procedures for removal of a cartridge when the barrel is carrier-mounted as described herein.

(1) The entire crew remains with the mortar.

WARNING

During peacetime live -fire training, when the water and antifreeze is used, the gunner joins the crew and waits the prescribed time. After waiting, the driver mounts the carrier first and then the gunner second.

(2) The gunner closes the ramp door. The driver lowers the ramp. The gunner signals the crew to mount the carrier.

(3) The driver moves to the left of the mortar, the squad leader moves to the right of the mortar, and the gunner and assistant gunner are in the firing positions. If the mortar is not centered, the gunner and assistant gunner now center the mortar toward the rear of the carrier.

(4) The gunner uses the traversing handwheel to center the mortar. The gunner removes the sight extension with the sightunit attached and places it on the carrier roof.

(5) The assistant gunner then elevates or depresses the mortar barrel to its lowest position in high range or to its highest position in low range (minus two turns). The gunner and assistant gunner must support the barrel while it is being lowered.

(6) The assistant gunner places his hands around the muzzle, making certain that no part of his hands extend over the muzzle. The gunner supports the barrel in front of the standard assembly.

WARNING

Never lower the base of the barrel below a horizontal position until the cartridge has been removed.

(7) The ammunition bearer removes the two detent pins. Then the squad leader and ammunition bearer carefully lift the base end of the barrel (without getting behind the barrel) and slowly raise it to the horizontal.

(8) The assistant gunner extends the thumbs of both hands over the muzzle as the barrel reaches the horizontal position. While the cartridge moves slowly toward the muzzle, the squad leader and ammunition bearer continue to raise the rear of the barrel.

WARNING

When removing the cartridge, the assistant gunner must not touch the striker since it may be armed.

(9) The assistant gunner stops the cartridge with his thumbs, removes it, and places it a safe distance from the mortar position (as prescribed by local policy). The squad leader and ammunition bearer shake the barrel to remove any debris. The barrel is then placed back into the firing position and the ammunition bearer swabs the barrel. Explosive ordnance disposal personnel are notified.

b. If the cartridge cannot be removed from the carrel (carrier-mounted), the crewmembers must follow these procedures:

(1) The gun crew returns the barrel to its horizontal position. The gunner pushes in, rotates, and disengages the mortar locking pin assembly, while supporting the standard assembly. The squad leader, assistant gunner, and ammunition bearer support the barrel, keeping it in the horizontal position.

(2) The squad leader, assistant gunner, and ammunition bearer remove the barrel from the standard assembly. Keeping the barrel horizontal, they place it on the ground in the direction of fire, a safe distance from the mortar. Explosive ordnance disposal personnel are notified.

Note: For more information on the disposition of misfires, see AR 385-63, TM 9-1300-206, or TM 9-1015-215-10.

6-22. MOUNTING OF MORTAR ON CARRIER FROM GROUND-MOUNTED POSITION

With the weapons system already out of action, the driver first ensures it is safe to lower the ramp and then does so.

a. The gunner and assistant gunner open the mortar hatch cover and ensure the turntable is centered to the rear of the track and locked. At the same time, the squad leader ensures that the detent pins are in their outermost detent positions.

b. With the gunner at the muzzle end of the mortar and the driver and squad leader at the base end of the mortar, they move the barrel into the carrier, base end first. The driver and squad leader place the tube cap trunnion pins into the tube socket, aligning the tube cap trunnion pin.

c. The gunner raises the muzzle end of the mortar high enough for the assistant gunner to mount the standard assembly. The assistant gunner aligns the standard base trunnion with the standard trunnion socket of the standard support, ensuring that the standard assembly is leaning toward the rear of the track when the trunnions are seated in the trunnion bearings. He then moves the standard assembly to the vertical position and supports the standard assembly.

Note: If the above procedures are not followed, the standard assembly can be emplaced improperly, causing undue stress on the standard support assembly.

d. The gunner lowers the barrel, aligning the locking lugs and standard assembly, pushes in the mortar locking pin assembly and turns it 180 degrees in either direction, locking the barrel to the standard assembly. He then ensures that the connection for the mortar locking pin assembly is centered, and that the standard assembly is fully depressed.

e. The assistant gunner secures the muzzle cover and tie-down strap, and places the muzzle cover on the barrel. He then hooks the ratchet end of the tie-down strap to the eye on the turntable and wraps the upper end around the barrel between the coupling and sight mount. After fastening the hook to the D-ring, he operates the ratchet until the strap is tight.

f. The bridge and baseplate assemblies are mounted by the gunner, the assistant gunner, and the driver. One mortarman always manipulates the bridge clamping assembly or baseplate locking clamp and, at the same time, aids in bracing these components. The rotator assembly is placed in its position on the right rear of the carrier.

g. The mortar and its components are now secured in the traveling position (Figure 6-19).

6-23. DISMOUNTING OF MORTAR FROM CARRIER

A minimum of four mortarman is required to remove the mortar and standard assembly from the travel position.

a. The driver ensures it is safe to lower the ramp and then does so. He joins the squad leader located at the base end of the mortar.

b. The assistant gunner removes the tie-down strap and muzzle cover from the mortar and stows them in the equipment bag. He then moves to the front of the mortar to support the standard assembly.

- c. The gunner unlocks the mortar locking pin and lifts up on the front of the mortar. The assistant gunner leans the standard assembly forward and removes it. The driver pulls the detent pins to their outermost detent positions.
- d. With the driver and squad leader at the base end of the barrel and the gunner at the muzzle end, they remove the barrel from the carrier.
- e. If the mortar is to be ground-mounted at this time, the crew removes the bridge, rotator, and baseplate assemblies from the carrier. The mortar is then mounted the same as in the previous paragraph.

6-24. PREPARATION FOR A MARCH ORDER FROM GROUND-MOUNTED POSITION

This exercise begins with the squad members at their firing posts at the ground-mounted mortar (Figure 6-24) and with the ramp of the carrier lowered. The preparatory command is PREPARE FOR MARCH ORDER; the command for execution is MARCH ORDER, upon which the crew proceeds as follows.

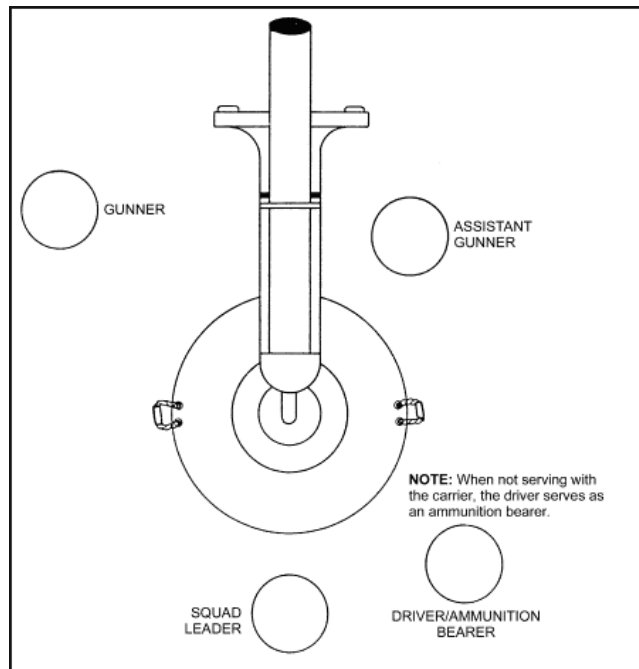

Figure 6-24. Firing posts (squad and mortar dismounted from carrier).

Note: When not serving with the carrier, the driver serves as an ammunition bearer.

a. Squad Leader.

- (1) Receives the sight from the gunner, places it in the sight case, and stows the case in the carrier.
- (2) Supervises the mounting of the mortar and the storing of the ammunition.
- (3) Directs the driver in the closing of the ramp.
- (4) Takes his mounted post.
- (5) Connects the breakaway plug.
- (6) Commands REPORT.
- (7) When the carrier is prepared for march order, reports, "Number one (two, three, or four); ready for march order."

b. Gunner.

- (1) Removes the sight and hands it to the squad leader.
- (2) Disconnects the barrel from the standard assembly.
- (3) Assists the ammunition driver/bearer and the driver in carrying and mounting the barrel.
- (4) Assists the assistant gunner in placing the mortar in the traveling position.
- (5) Assists the driver and assistant gunner in replacing the bridge and baseplate assemblies.
- (6) Assists the ammunition bearer/driver in carrying and stowing ammunition.
- (7) Assists in closing the mortar hatch cover.
- (8) Takes his mounted post.
- (9) Reports, "Gunner ready."

c. Assistant Gunner.

- (1) Swabs out the bore.
- (2) Mounts the recoil stop on the standard assembly.
- (3) Assists the ammunition bearer and gunner in carrying and stowing the baseplate and bridge assemblies.
- (4) Assists the gunner in placing the mortar in the traveling position.
- (5) Dismounts and mounts the standard assembly.
- (6) Attaches and tightens the traveling strap assembly to the mortar.
- (7) Stows the cleaning staff and places the muzzle cover on the barrel.
- (8) Assists the ammunition bearer in carrying and stowing ammunition.
- (9) Assists in closing the mortar hatch cover.
- (10) Takes his mounted post.
- (11) Reports, "Assistant gunner ready."

d. Driver.

- (1) On command of the squad leader, raises and lowers the ramp.
- (2) Moves the carrier as directed by the squad leader.
- (3) Stows the rotator assembly.
- (4) Assists the gunner and assistant gunner in mounting the mortar.
- (5) Takes his mounted post.
- (6) Reports, "Driver ready."
- (7) Assists the gunner and assistant gunner in dismounting, carrying, and stowing the bridge and baseplate assemblies.
- (8) Retrieves the aiming post.
- (9) Places the detent pins in the innermost detent.

6-25. SAFETY CHECKS

Specific safety checks must be performed before firing from the M106, M106A1, or M106A2 carrier. Most checks can be made by visual inspection. The gunner, assistant gunner, and ammunition bearer are responsible for physically performing these safety checks under the squad leader's supervision. The squad leader supervises to ensure that all precautions are taken to prevent possible damage to equipment or injury to personnel.

a. Gunner Safety Checks.

- (1) The trunnion detent pins are in the innermost detent.
- (2) The traversing lock handle is locked.
- (3) The standard support assembly is in a raised position and firmly latched.
- (4) The standard base trunnions are correctly aligned and seated in the standard support trunnion bearing.
- (5) The elevating mechanism cam is locked and operational.
- (6) The recoil stop is in position and the wing nut is tight.
- (7) The mortar locking pin is fully seated and locked.
- (8) A mask and overhead clearance exist through the entire traverse capability of the mortar mounted on the carrier.
 - (a) When a mask and overhead clearance do not exist at points along the full traverse and elevation capability of the mortar, the gunner traverses the barrel (using the turntable when necessary) and, by sighting along the barrel, aligns the barrel with the obstruction. Using the sight, he then measures the elevation, refers the sight back to the aiming posts, and takes a correct sight picture.
 - (b) When referring back to sight, he measures the number of mils, left or right, that the mask or overhead obstruction covers and announces the result to the squad leader.
- (9) The two mortar hatch covers are securely latched.

b. Assistant Gunner Safety Checks.

- (1) The mortar barrel is clear of foreign materials.

(2) The bore is swabbed before firing, and after every 10 rounds or fire for effect.

(3) The left mortar hatch cover is securely latched.

c. Ammunition Bearer Safety Checks.

(1) The rounds are clean and free of burrs.

(2) The fuze is screwed tightly against the shell body. If the fuze is loose, he tightens it with the correct fuze wrench.

(3) The correct charge is placed on each round and the propelling charges are properly positioned.

(4) The striker nut is tight.

(5) The proper fuze option or fuze time setting is selected.

6-26. MEASUREMENT OF MINIMUM AND MAXIMUM ELEVATIONS

When in a firing position, mortar carriers should be positioned on the best obtainable level ground. If the carriers are not on level ground, the mortars may not be able to fire at certain elevations because of the longitudinal cant of the carrier. When the carrier is positioned, the gunner measures the minimum elevations that can be obtained on his mortar by elevating and depressing the mortar barrel and measuring with his sight. He gives the results of his measurements to the squad leader who in turn informs the FDC. The FDC then determines which constant elevation to fire and may direct the squad leader to move his carrier to a new position.

Note: The sight must be calibrated before minimum and maximum elevations are measured.

6-27. SQUAD FORMATIONS

This paragraph discusses the traveling and firing positions of the squad members.

a. Traveling Posts. The squad takes traveling posts as follows:

(1) Squad leader: in the cupola, standing on the platform or seated on the cupola seat.

(2) Gunner (No. 1): on the gunner's seat, facing the assistant gunner (No. 2).

(3) Assistant gunner (No. 2): on the assistant gunner's seat, facing the gunner.

(4) Driver: in the driver's seat.

b. Firing Posts (Mounted). When the carrier-mounted mortar is prepared for action, the squad members take their firing positions as follows:

(1) Squad leader: any position in the carrier that allows him to supervise the action of the squad.

(2) Gunner (No. 1): to the left of the mortar where he can lay for elevation and direction.

(3) Assistant gunner (No. 2): to the right of the mortar where he can load the mortar and cross-level the sight for the gunner.

(4) Driver: in the driver's seat or the seat next to the vertical ammunition rack.

c. Firing Posts (Dismounted). When the mortar is ground-mounted and prepared for action, the squad members take their firing posts. The driver remains with the carrier.

6-28. DISMOUNTED MORTAR SQUAD

This exercise (Figure 6-25) begins with the squad members at their traveling posts with the ramp and ramp door closed. The preparatory command is PREPARE TO DISMOUNT; the command of execution is DISMOUNT. A mounted squad drill should be practiced under section and squad control.

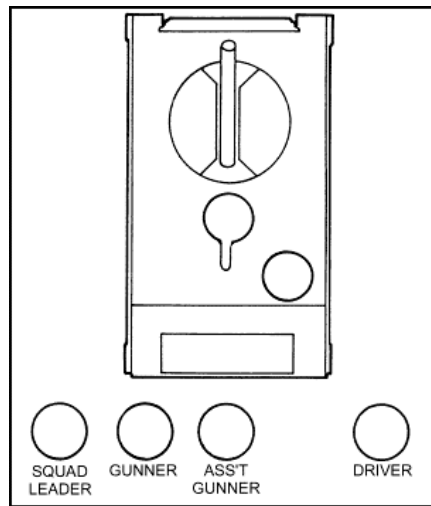

Figure 6-25. Dismounted posts.

- a. At the command PREPARE TO DISMOUNT, the driver disconnects the breakaway plug and turns off the master switch. The squad leader disconnects the breakaway plug and turns off the radio. The assistant gunner unlatches and opens the ramp door.
- b. At the command DISMOUNT, the assistant gunner, gunner, squad leader, and driver (in that order) dismount, move to the front of the carrier, and take their dismounted posts. Squad members move around the carrier using the fastest route available.

6-29. RECIPROCALLY LAYING THE MORTAR CARRIER SECTION

When fully trained, the mortar squad increases the speed and accuracy of the section functioning as a unit.

- a. The procedure for laying the carrier-mounted mortar parallel on the mounting azimuth is the same as for the ground-mounted mortar, with the following exceptions:
 - (1) When the first deflection is given to the mortars identifying the aiming point, all carrier engines are running.
 - (2) Intercom between the gunner and drivers is maintained until the carriers cease further pivots. The connection for the mortar locking pin

assembly is centered or is within two turns of center. The mortars are centered on the rear of the carriers and the correct sight pictures are on the aiming point. At this time, the carrier engines are turned off.

b. When a reconnaissance of a position has been made and is known by at least one member of the platoon, the procedure for laying the carrier-mounted mortars parallel on the mounting azimuth is as follows (ramps are always up for this exercise):

(1) The instrument operator, if not already in position, dismounts from the command post carrier and positions his instrument 75 meters to the front, right front, or left front of the area occupied by the carriers. He then orients the aiming circle on the mounting azimuth. He swings the aiming circle telescope, by using upper motion, in the general direction of the mortar carriers and awaits the signal from the squad leader when ready to be laid for direction. The instrument operator reciprocally lays the mortar squad upon signal from the first squad leader (normally the base squad) ready to be laid for direction.

(2) As soon as the base squad is positioned, the squad leaders align their respective squads: first squad 40 meters to the right of the base squad; and third squad 40 meters to the left of the base squad (left and right are given in relation to the direction of fire). All squad leaders note the alignment of the base squad and direct their drivers by intercom to pivot, aligning their respective carriers parallel to the base squad.

(3) The squad leaders then command PREPARE FOR ACTION. While the gunners and assistant gunners are placing the mortars into the firing positions, the squad leader is carrying the aiming posts, dismounting from the carriers through the ramp door, latching the door from the outside, and moving half the distance between their carriers and the instrument operator to relay commands.

(4) As soon as the gunners command UP, the squad leaders signal to the instrument operator I AM READY.

(5) On the command UP, the gunners immediately refer their sights to the aiming point, even though the command AIMING POINT THIS INSTRUMENT has not been given. The gunners are up when the connection for the mortar locking pin assembly is centered; the mortars are centered to the rear of the carriers; the sights are set at elevation 900 and 3200 deflection (zero with the M64-series); and the cross-level and elevation bubbles are centered.

(6) When the first deflection command is given, the gunners then index the sights at the given deflection and note the direction the telescopes

move. They look through the telescopes and signal to the drivers (who should be observing) the direction to pivot the carrier. The gunners may give this direction over the intercom to the drivers as a command PIVOT RIGHT (LEFT) and terminate the pivot by the command HALT. The gunners finalize the lay on the aiming point with all bubbles centered, ensuring that it does not take in excess of two turns to lay on the aiming point. The gunners then signal the drivers to cut the carrier engines. The gunners may transmit this signal to the drivers as a command CUT ENGINE.

(7) The instrument operator successively lays each squad. The carrier-mounted mortars are properly laid on the mounting azimuth when the connection for the mortar locking pin assembly is within two turns of center; the mortars are centered to the rear of the carriers; the last deflection given by the instrument operator is on the sights; all bubbles are centered; and the last sight picture obtained by the gunners is on the optical center of the aiming point.

(8) Without command, the gunners refer the sights to the deflection 2800 and direct the squad leaders in aligning the aiming posts. If any other referred deflection is to be used, the instrument operator announces this deflection before laying the mortar squads.

Section VI. AMMUNITION

This section implements STANAG 2321 and QSTAG 900 Edition 1.

Ammunition for the 4.2-inch mortar, M30, is issued in the form of semi-fixed complete rounds. A complete round of ammunition composes all of the ammunition components required to fire the round. For mortar ammunition, this includes a loaded projectile propelling charge to develop the required gas pressure to propel the projectile to its target, primer to initiate the burning of the ignition charge that ignites the propelling charge, and fuze to cause the projectile to function at the time and under the conditions desired. Semi-fixed ammunition is characterized by an accessible propelling charge that can be adjusted for firing. The propelling charge consists of an ignition cartridge and 41 propellant increments (39 for M329A2) assembled in a bag and sheets. To adjust the charge, the individual increments are removed from the cartridge container or cartridge container extension.

6-30. CLASSIFICATION

The 4.2-inch mortar ammunition is stabilized in flight by rotation rather than by fins as in the case of the 60-mm and 81-mm mortar ammunition (Table 6-3).

CARTRIDGE	TYPE	STANDARD	MINIMUM RANGE	MAXIMUM RANGE	EFFECTIVE RANGES	AVERAGE VELOCITY	RATE OF FIRE	COLOR CODING
-----------	------	----------	---------------	---------------	------------------	------------------	--------------	--------------

			(METERS)	(METERS)	AREA (METERS)	TIME (SECONDS)	(MPS)	
M329A2	HE	A	770	6,840	40E20			OLIVE DRAB WITH YELLOW MARKINGS
M329A1	HE	(B)	920	5,650	40E20			OLIVE DRAB WITH YELLOW MARKINGS
M328A1	SMOKE	A	920	5,650				LIGHT GREEN WITH RED MARKINGS, YELLOW BAND
M325A2	ILLUM		400	5,490	1,500-METER DIAMETER	90	5	WHITE WITH BLACK MARKINGS
M335A1	ILLUM		640	5,290	800-METER DIAMETER	70	10	WHITE WITH BLACK MARKINGS
M2A1	GAS	A	870	4,540				TOXIC, NONPERSISTENT, GREY WITH GREEN MARKINGS, ONE GREEN BAND, ONE YELLOW BAND (IF BURSTER PRESENT)
M2	GAS	(B)	870	4,540				TOXIC, PERSISTENT, GREY WITH GREEN MARKINGS, TWO GREEN BANDS, ONE YELLOW BAND (IF BURSTER PRESENT)
XM430	TAC/CS			5,650		60		TOXIC V AND G AGENT, GREY WITH GREEN MARKINGS, THREE GREEN BANDS, ONE YELLOW BAND (IF BURSTER PRESENT) IRRITANT, NONPERSISTENT, GREY WITH RED MARKINGS, ONE RED BAND, ONE YELLOW BAND (IF BURSTER PRESENT) IRRITANT, PERSISTENT, GREY WITH RED MARKINGS, TWO RED BANDS, ONE YELLOW BAND (IF BURSTER PRESENT)

Table 6-3. Ammunition for 4.2-inch mortar, M30.

a. **Identification.** Ammunition is identified by the markings on the original packing containers, which includes the ammunition lot number. Once removed from its packing, ammunition can also be identified by its color and markings.

Note: For further information concerning identification, model designation, lot number, painting and markings, and weight zones, refer to TM 9-1300-200. For the NATO color-coding standard, refer to TB 9-1300-256 and TB 34-9-93.

b. **Type.** Depending on the type of projectile filler, ammunition is classified as high explosive (HE), smoke (PWP or WP), or illumination (Figures 6-26 to 6-28).

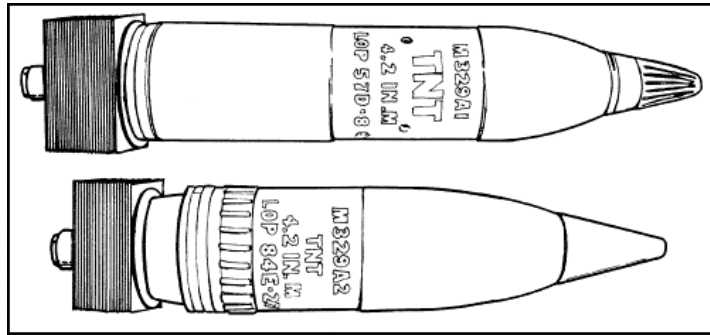

Figure 6-26. High-explosive 4.2-inch cartridges, M329A1 and M329A2 showing supplemental charge.



Figure 6-27. White phosphorus smoke 4.2-inch cartridge M328A1.

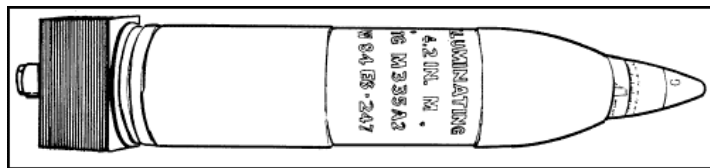

Figure 6-28. Illuminating 4.2-inch cartridge, M335A2, with mechanical time fuze, M565.

Note: For detailed information on mortar ammunition, see TM 9-1015-215-10, TM 9-1300-200, TM 9-1300-206, TM 43-0001-28, and FT 4.2-H-2.

6-31. TYPES OF FUZES

A fuze is a device used to explode a projectile at the time and under the circumstances required (Table 6-4).

CARTRIDGE	FUZE													
	FD				MT		MTSQ					PROX		
	M8	M48A3	M521	M51A5	M557	M562	M565	M501A1	M548	M577	M564	M520 Series	M513 Series	M514A1E1
CS M630									X					
GAS M2A1	X													
HE M329A1				X	X						X	X	P	
HE M329A2 (M329A1E1)					X						X	X		P
ILLUM M335A1						X		X						
ILLUM M335A2							X			X				
SMOKE WP M328		X												
SMOKE WP M328A1		X	X											

PD-POINT DETONATING
MT-MECHANICAL TIME
MTSQ-MECHANICAL TIME SUPERQUICK
PROX-PROXIMITY
P-REQUIRES REMOVAL OF SUPPLEMENTARY CHARGE, IF USED.

NOTE: When using the M732 fuze, see TM 43-0001-28.

Table 6-4. Fuze combination table for 4.2-inch mortar ammunition.

a. **Classification.** Three types of nose fuzes are used with the 4.2-inch mortar ammunition: time, impact, and proximity.

(1) *Time fuze.* This fuze is designed to function while the round is still in flight. Certain time fuzes are also provided with a backup impact element (time and impact). There are two types of time fuzes:

(a) Mechanical time. This fuze uses a clockwork mechanism to delay functioning for a specific time.

- MTA--The entry to select for an air burst option when computing data with the M23 MBC (4.2-inch only).
- MTB--The entry to select for a below-surface burst option when computing data with the M23 MBC (4.2-inch only).

(b) Powder-train time. This fuze uses a compressed black powder train to delay functioning for a specific time.

(2) *Impact fuze*. This fuze functions upon striking a resistant object. It is classified according to the time of function after impact as superquick or delay.

(3) *Proximity fuze*. This is a radio-activated point fuze that functions either after a preset arming time or, without setting or adjustment, upon approach to a target.

b. Bore-safe Fuze. A bore-safe fuze is one in which the explosive train is so interrupted that, while the round is still in the bore of the weapon, premature action of the bursting charge is prevented should any of the more sensitive elements (primer or detonator) function. The fuzes used with the ammunition described in this manual are considered *bore safe*.

6-32. PREPARATION OF AMMUNITION

To prepare a round for firing, remove the round from its container and the U-shaped packing stop from the tail assembly. Examine the round for burrs or deformities that might cause the round to stick in the tube or to malfunction. Ammunition with serious defects is not used. When handling a projectile, protect its base with the fiber container. Handle a round with its base up to protect the sensitive primer.

a. **Propelling Charges.** Propelling charges M6, M36A1, and M36A2 are used with 4.2-inch cartridges (Figure 6-29).

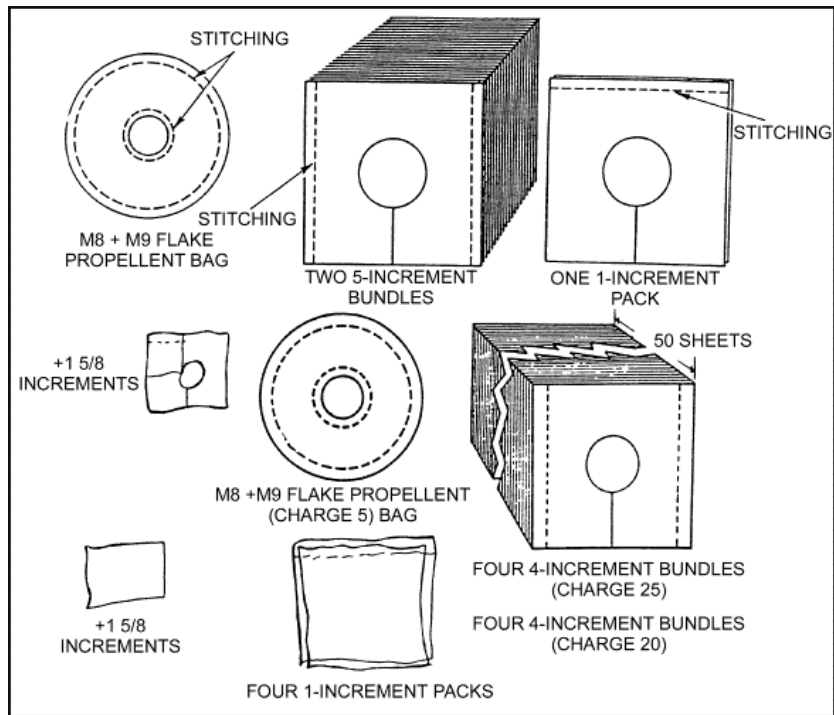

Figure 6-29. Arrangement of propelling charges.

Note: When using propellants M36A1 or M36A2, duds can occur when firing below charge 7.

(1) *Propelling charge, M6.* The M6 propelling charge consists of 25 1/2 increments assembled in the form of one half-increment sheet, four 5-increment bundles, and five single increments. The individual increments can be removed for firing adjustment (charge firing). The full propelling charge is assembled to the cartridge as issued. Maximum range is obtained with the full charge; lesser ranges, with fewer increments as indicated in the appropriate firing tables. The method of securing the propellant increments differs from round to round. In full charge for M2A1 chemical (gas or smoke) cartridges, increments are held firmly between the pressure plate nut and propellant holder.

(2) *Propelling charge, M36A1 and M36A2.* The M36A1 and M36A2 propelling charges differ from the M36 propelling charge in that a doughnut-shaped cloth bag containing M9 flake propellant replaces the first five M8 sheet propellant increments. This doughnut-shaped bag is not removed at any time. The striker nut assembly and cartridge container extension have been modified to allow direct ignition of the propellant, eliminating the need for changing the position of the ignition cartridge when the extension is removed.

b. Ignition Cartridges. The M2 ignition cartridge is used with the M6 propelling charge, and the M2A1 ignition cartridge is used with the M36A1 propelling charge. Both ignition cartridges contain a primer and look like a commercial 12-gauge shotgun cartridge. The M2A2 ignition cartridge, which has greater resistance to moisture and longer shelf life than the M2A1 ignition cartridge, is used with the M36A1 propelling charge only in the XM630 tactical CS M335A2 illuminating cartridge, and the M329A2 cartridge with the M36A2 propelling charge.

c. Adjustment of the Propellant Charge. The M329A2 cartridge is assembled with the M36A2 propellant charge. It composes a bag charge containing M8 propellant flakes and M8 propellant sheets.

(1) The bag charge is needed for proper burning of the propellant sheets and must not be removed in charge adjustment. The bag charge is located in the center of the propellant charge and must not be repositioned. The bag must be positioned over the flash holes in the center of the tail assembly for proper ignition. The cartridge is shipped with a full charge assembled, which includes 39 increments with the bag charge counted as five charges.

(2) The propellant charge is arranged from the base of the projectile as follows:

- Three 5-increment bundles.
- Five 1-increment bundles.
- A bag charge of five increments.
- Two half-increment sheets.
- Three 1-increment bundles.
- Two 5-increment bundles.

Note: Only Firing Table 4.2-K-2 may be used to determine the proper charge of firing for the M329A2.

(3) Propellant charges should be removed equally from both sides of the bag charge until the required charge remains. Excess charge sheets should

be placed in an empty wooden box with a lid to prevent accidental ignition during firing.

d. **Procedures.** To ensure proper ignition of increments when using the M6 propelling charge at less than full charge, the increments must cover the flash holes in the cartridge container and push up firmly against the striker nut. To use the M36A1 propelling charge with fewer than 25 1/2 increments, the cartridge container extension is removedXthe ignition cartridge does not require repositioning.

e. **Precautions.** Inspection for proper assembly of propelling charge is essential to avoid excessive chamber pressures, erratic ranges, and short rounds. When firing at any charge other than maximum charge, the propelling charge must be varied depending on the mortar-target range. (Charges are set so that increments of 1/8, 2/8, or 3/8 will not stick between the 5-increment or 1-increment bundles. The procedure when a charge ends with 1/8, 2/8, or 3/8 is demonstrated in Figure 6-30.

16 2/8 CHARGE

Bag	= 5 increments
Two 5-increment bundles	= 10 increments
Two 5/8-increment sheets	= 1 2/8 increments
Total	= 16 2/8 increments

30 1/8 CHARGE

Bag	= 5 increments
Four 5-increment bundles	= 20 increments
Four 1-increment sheets	= 4 increments
One 4/8-increment sheet	= 4/8 increment
One 5/8-increment sheet	= 5/8 increment
Total	= 30 1/8 increments

11 2/8 CHARGE

Bag	= 5 increments
One 5-increment bundle	= 5 increments
One 6/8-increment sheet	= 6/8 increment
One 4/8-increment sheet	= 4/8 increment
Total	= 11 2/8 increments

24 3/8 CHARGE	
Bag	= 5 increments
Three 5-increment bundles	= 15 increments
Three 1-increment sheets	= 3 increments
One 5/8-increment sheet	= 5/8 increment
One 6/8-increment sheet	= 6/8 increment
Total	24 3/8 increments

Figure 6-30. Examples of charges ending with 1/8, 2/8, or 3/8.

f. Preparation of an Unfuzed and Fuzed Deep-Cavity Round. The procedures for preparing an unfuzed and fuzed deep-cavity round are as follows:

- (1) To prepare an unfuzed or fuzed round for firing with mechanical time superquick (MTSQ) fuze--
 - (a) Use the cover of the fiber container to cover the striker nut, cartridge extension, and propelling charge before fuzing the round. This cover protects against accidental ignition.
 - (b) Place the round on its side with the closing plug or fuze pointing to the right.
 - (c) Remove the closing plug. If a round is fuzed, insert an M18 or M7A1 fuze wrench in the wrench slots of the fuze, ensuring the proper slot is used. Strike the wrench handle sharply with the hand in a counterclockwise direction while looking downward on the fuze. Do not strike any part of the fuze. Unscrew and remove the fuze.
 - (d) Inspect the cavity for damage and the presence of foreign material, and remove any loose material. If any HE filler is found adhering to the threaded portion of the fuze cavity, place the round aside for disposal by qualified ammunition personnel.
 - (e) Examine the nose threads and fuze to ensure they are in good condition--do not use components with damaged threads.
 - (f) Screw the fuze into the fuze cavity and tighten it securely with an M18 or M7A1 fuze wrench. Make sure the fuze shoulder seats firmly against the nose of the shell so that no space exists between them. Do not remove the supplementary charge.

(g) If not fired, restore the fuze and shell to their original condition and packing.

(2) To prepare an unfuzed or a fuzed deep-cavity round for firing with the M513 proximity fuze--

(a) Perform the steps outlined above.

(b) Using the tab lifting loop, remove the supplementary charge. Screw in the proximity fuze by hand. If the fuze binds, inspect the fuze cavity and the threads of both fuze and shell. Reject whichever is defective.

(c) Tighten the fuze with the M18 fuze wrench. Use only such force as can be applied by hand. Do not hammer on the wrench or use an extension handle. Do not force the fuze to the cartridge under any circumstances. If the fuze cannot be tightened to form a good seat between the shell and fuze, reject the defective component.

g. Preparation of the Fuze for Firing. The procedures for preparing the fuze for firing are as follows.

(1) *M535 fuze.* To set the fuze for delay action, turn the slot 90 degrees to align it with the index mark for DELAY. The setting can be changed for firing with the screwdriver end of the M18 fuze wrench or a similar tool. If nighttime, feel for the slot position and make the correct setting.

(2) *M563 MTSO Fuze.* Remove the safety wire from the fuze. If only impact action is desired, set the fuze for 100 seconds. Do not fire fuzes when set on the shipping mark "S." If time action is required, set the fuze to the desired time to the nearest 1/2 second using the M14, M26, M27, or M63 fuze setter.

Note: If the fuze is not fired after setting, reset the fuze to SAFE and replace the safety wire in its proper position before defuzing the round and returning the components to their packing containers. Turn the fuze in a clockwise direction only.

(3) *M513 Proximity fuze.* Make time settings the same as for a mechanical time fuze. Looking down on the nose of the fuze, rotate the M28 fuze setter in a clockwise direction. If point detonating action is desired, place a time setting of 90 seconds on the fuze.

(4) *M572 and M565 mechanical time fuzes.* These fuzes are used with the base-ejection M335A1 and M335A2 illuminating projectiles. Because of size and difference in threads, they cannot be interchanged with the MTSQ M501A1 fuze. These fuzes differ from the MTSQ M501A1 fuze in that they have a vernier scale to allow for accurate settings to the nearest .1 second. Set time by turning the fuze in a clockwise direction only. For further information on these fuzes, see TM 43-0001-28.

(5) *M557 point-detonating fuze.* This fuze is similar to the PD 51A5 fuze. The difference is that the M557 fuze contains a booster M125A1, which is a manufacturing component of the fuze and incorporates a delayed arming feature. This fuze is a combination superquick/delay fuze.

Note: When making time settings using the time fuzes, follow the NO-BACKUP rule, since backing up can damage the internal workings of some fuzes. To do so, the fuze time scale is made to turn clockwise. If the time required is exceeded, continue to turn the fuze until the proper time is in line again. If the time is exceeded and the fuze is turned counterclockwise, the internal parts of the fuze may be damaged, causing some fuzes to malfunction.

6-33. CARE AND HANDLING

Because explosives are adversely affected by moisture and high temperature, the following precautions must be observed

- a. Do not break the moisture-resistant seal on the fiber container until the ammunition is to be used.
- b. Protect the ammunition (particularly the fuze and the propellant) from high temperatures, including the direct rays of the sun. More uniform firing is obtained when the rounds are at the same temperature. When the filling of the white phosphorous (WP) shell melts (111.4 degrees F) and then hardens in any position other than on its base, a large percentage of the rounds will tumble in flight and result in duds. To prevent this, store WP-filled shells in an upright position (fuze end up).
- c. Do not remove safety devices from the fuze until just before firing.
- d. Keep the round and the propelling charges dry. Moisture causes incomplete combustion of the propelling charges, reduces the range, and can cause short rounds.
- e. When ammunition is left in the open, place it on at least six inches of dunnage and cover it with a double thickness of tarpaulin. Dig trenches around the pile to prevent water from flowing under it.

Note: For further precautions in storage, see TM 9-1015-215-10, TM 9-1300-206, and FM 9-207.

f. Before loading the round, make sure it is free of foreign matter such as sand, mud, and grease.

g. Protect the propelling charges of the rounds prepared for firing by slipping one end of the fiber container over the base of the round.

h. Return rounds prepared for firing to their original condition by reinserting the safety pins (when applicable), replacing the packing, and repacking the rounds into their original containers. Inspects fuzes before repacking. To keep opened stocks at a minimum, use repacked rounds first in subsequent firing exercises.

WARNING

Do not handle duds; the fuzes could be armed. Duds are extremely dangerous. Do not move or turn them. To dispose of duds, immediately call the nearest EOD unit.

i. To maintain accuracy in firing, it is important that ammunition of the same lot number be used on a given mission.

j. To know how much ammunition of a given lot number each squad has, ammunition should be stored by lot number. Storing ammunition by lot number also facilitates keeping track of suspended lots of ammunition as well as giving a means of determining which ammunition has been on position the longest. Ammunition that has been on position the longest should be fired first.

k. When repacking, do not mix lot numbers of ammunition.

CHAPTER 7

120-mm MORTAR, M120

The 120-mm mortar delivers timely, accurate fires to meet the requirements of supported troops. This chapter discusses assigned personnel duties, organization, mounting the mortar, and characteristics.

Section I. SQUAD AND SECTION ORGANIZATION AND DUTIES

Each member of the infantry mortar squad has principle duties and responsibilities.

7-1. ORGANIZATION

For the mortar section to operate effectively, each squad member must be proficient in his individual duties. By performing those duties as a team member, he enables the mortar squad and section to perform as a fighting team. The platoon leader commands the platoon and supervises the training of the elements. He uses the chain of command to assist him in effecting his command and supervising duties.

7-2. DUTIES

The mortar squad consists of five men (Figure 7-1). Their firing positions and principal duties are as follows:

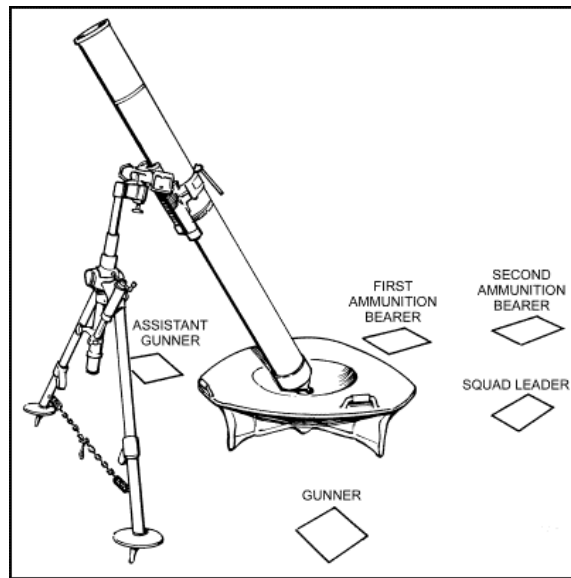

Figure 7-1. Position of squad members.

- a. The *squad leader* stands behind the mortar where he can command and control his squad. In addition to supervising the emplacement, laying, and firing of the mortar, he supervises all other squad activities.
- b. The *gunner* stands to the left side of the mortar where he can manipulate the sight, elevating handwheel, and traversing handwheel. He places firing data on the sight and lays the mortar for deflection and elevation. He makes large deflection shifts by shifting the bipod assembly and keeps the bubbles level during firing.
- c. The *assistant gunner* stands to the right of the mortar, facing the barrel and ready to load. In addition to loading, he swabs the bore after 10 rounds have been fired or after each fire mission. He assists the gunner in shifting the mortar when the gunner is making large deflection changes.
- d. The *first ammunition bearer* stands to the right rear of the mortar. He has the duty of preparing the ammunition and passing it to the assistant gunner. He is also the squad driver.
- e. The *second ammunition bearer* stands to the right rear of the mortar behind the ammunition bearer. He maintains the ammunition for firing and provides local

security for the mortar position. He performs other duties as the squad leader directs. He is also the driver for the ammunition vehicle.

Section II. COMPONENTS

This section contains the technical data and description of each component of the 120-mm mortar (Figure 7-2). The mortar is a smooth-bore, muzzle-loaded, crew-served, high angle-of-fire weapon. It consists of a cannon assembly, bipod assembly, and baseplate. The 120-mm mortar is designed to be employed in all phases and types of land warfare, and in all weather conditions. (See TM 9-1015-250-10 for detailed information.)

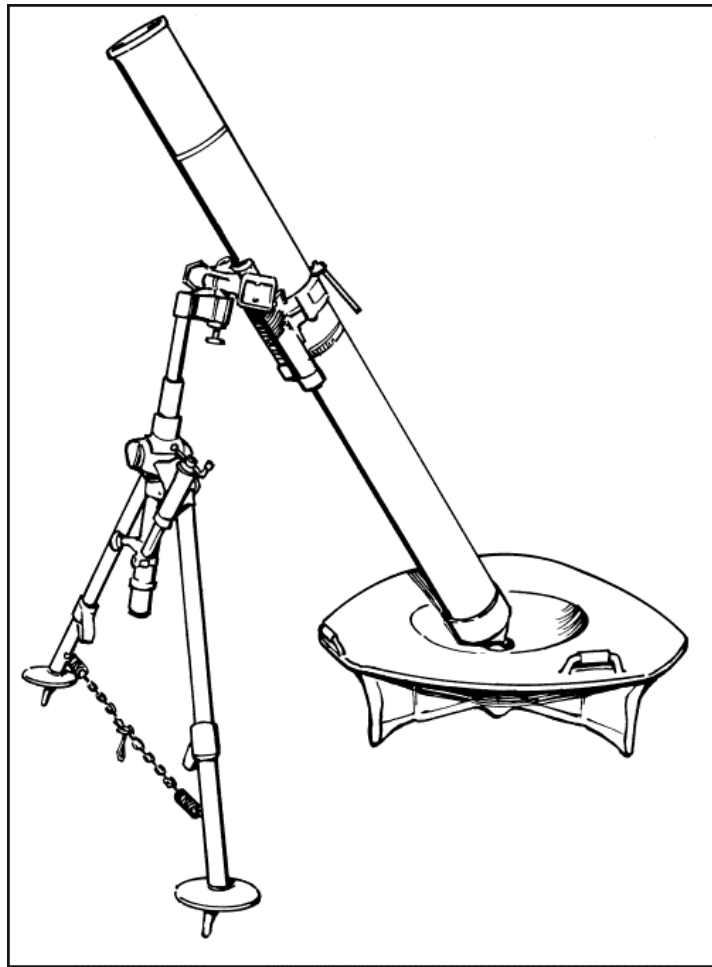

Figure 7-2. The 120-mm mortar.

7-3. TABULATED DATA FOR THE 120-mm MORTAR, M120

The tabulated data for the 120-mm mortar are as shown in Table 7-1.

Weights (pounds)

Cannon	110.0
Bipod	
M190 (ground-mounted)	70.0
M191 (carrier-mounted)	78.0
Baseplate	136.0
M67 sightunit	2.5
Trailer	399.0
Elevation (approximate mils)	
Elevation	0710 to 1510
For each turn of elevation crank	5
Traverse (approximate mils)	
Right or left from center using traversing wheel	136
With extension	316
One turn of traversing wheel	5
Range (meters)	
Maximum	7,200
Minimum	200
Rate of Fire (rounds per minute)	
Maximum	16 (first minute)
Sustained	4 (indefinitely)
Bursting Radius (meters)	75

Table 7-1. Tabulated data for the 120-mm, M120 mortar.

7-4. BARREL ASSEMBLY, M298

The barrel assembly consists of two parts: the tube and the base cap (Figure 7-3). The rear end of the tube is threaded to form a seat, which functions as a gas seal and centers the base cap.

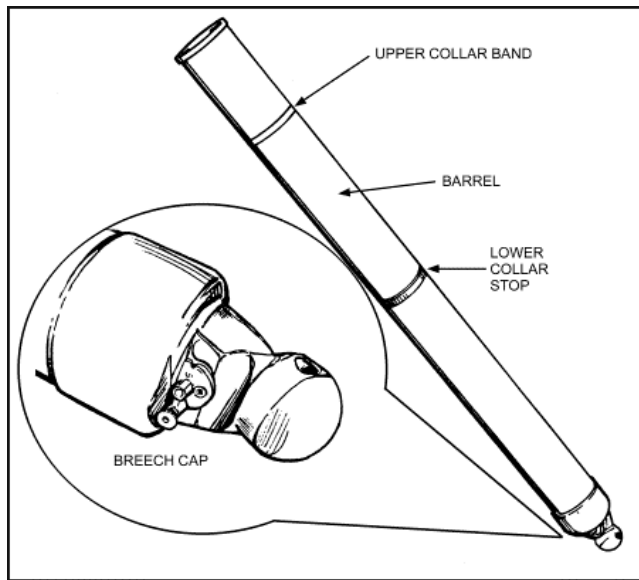

Figure 7-3. Barrel assembly, M298.

- a. The base cap screws into the base end of the tube with the front end of the base cap mating to the seat on the tube, forming a gas-tight metal seal. The external rear portion of the base cap is tapered and has a ball-shaped end. This end is cross-bored to help inserting or removing the base cap and locking it into firing position. The safety lever has two positions: F for fire and S for safe.
- b. When the safety lever shows the letter F, the firing pin protrudes and is in the fire position. When the lever shows the letter S, the weapon is in the safe position and the firing pin is withdrawn.

Note: The barrel and cap are serial numbered identically. They should not be interchanged.

7-5. BIPOD ASSEMBLY, M191 (CARRIER/GROUND-MOUNTED)

The bipod assembly, M191 (carrier/ground-mounted) (Figure 7-4) consists of the following main parts:

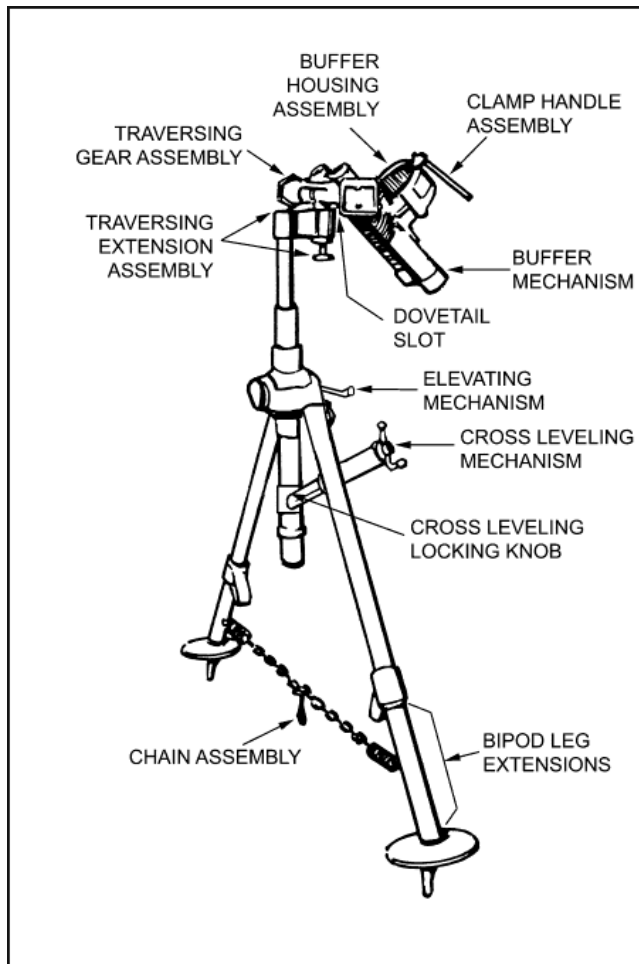

Figure 7-4. Bipod assembly, M191 (carrier/ground-mounted).

- Bipod leg extensions.
- Cross leveling mechanism.
- Traversing gear assembly.
- Traversing extension assembly.
- Elevating mechanism.
- Buffer housing assembly.
- Buffer mechanism.

- Clamp handle assembly.
- Cross leveling locking knob.
- Chain assembly.

7-6. BIPOD ASSEMBLY, M190 (GROUND-MOUNTED)

The bipod assembly, M190 (ground-mounted) (Figure 7-5) consists of the following main parts:

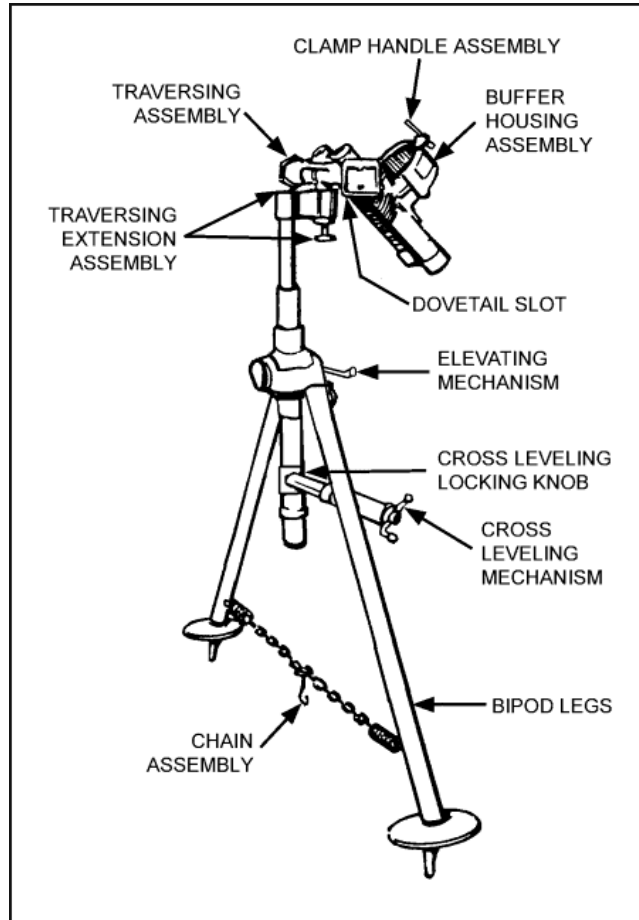

Figure 7-5. Bipod assembly, M190 (ground-mounted).

- Clamp handle assembly.
- Buffer housing assembly.
- Dovetail slot.
- Elevating mechanism.
- Cross leveling locking knob.
- Cross leveling mechanism.
- Chain assembly.
- Traversing extension assembly.
- Traversing gear assembly.
- Bipod legs.

7-7. BASEPLATE, M9

The baseplate (Figure 7-6) is shaped like a rounded triangle. It has a socket that enables a full 360-degree traverse without moving the baseplate. It also has legs (spades) under the baseplate, two carrying handles, and one locking handle.

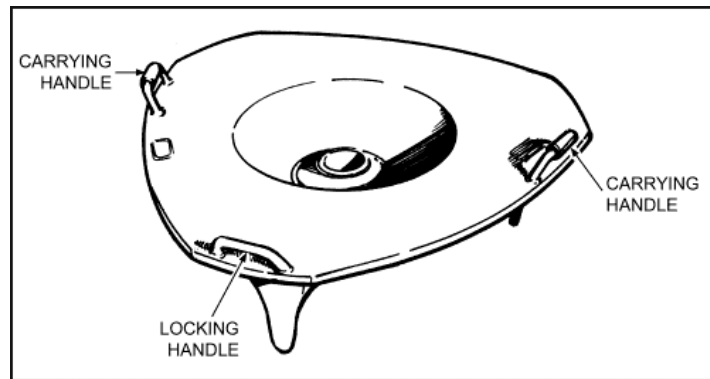

Figure 7-6. Baseplate, M9.

Section III. OPERATIONS

This section explains how to place the mortar into action by ground-mounting and leveling the weapon system from the trailer position; how to conduct safety checks; and what actions the crew applies to remove the cartridge from the barrel if a misfire should occur during firing.

7-8. PLACING A GROUND-MOUNTED 120-mm MORTAR INTO ACTION

The assistant gunner and two ammunition bearers are present. The mortar must be ground-mounted within 1 minute and 15 seconds. The M67 sight is set with a deflection of 3200 mils and an elevation of 1100 mils. All bubbles are centered within the outer red

lines. The traversing extension is locked in the center position. The bearing is the center of traverse. The barrel is locked into the baseplate with the white line up (on top). The bipod barrel clamp is positioned and locked. The bipod locking knob is hand tight.

Note: Left and right are in relation to the mortar's direction of fire.

- a. The driver/first ammunition bearer exits the mortar carrier and moves to the driver's side of the mortar trailer hitch. At the same time, the second ammunition bearer exits the armament vehicle and moves to the passenger's side of the mortar trailer hitch.
- b. Together, they unhook the trailer from the vehicle and position the trailer at the firing position with the baseplate toward the direction of fire. The first ammunition bearer then removes the muzzle plug.
- c. The assistant gunner exits the vehicle with the aiming posts and places them to the right side of the mortar.
- d. Once in position, both ammunition bearers raise the trailer until the baseplate is resting on the ground. The second ammunition bearer then releases the trailer while the first ammunition bearer continues to hold the trailer in place. The second ammunition bearer moves around to the right side of the mortar to assist in mounting the mortar.
- e. The gunner exits the vehicle with the sight and places it on the left side of the mortar. He then moves up to the left side of the mortar and removes the lock release lever pin. He releases the mortar baseplate and unhooks the bipod chain from the eye on the bipod leg and drops it. He then loosens the cross-level locking knob.

WARNING

Stay clear of the mortar baseplate to avoid injury from sudden release.

- f. The assistant gunner assumes his position on the right side of the mortar. He releases the lock release lever and then the clamping catch, and swings the trailer bridge assembly out of the way. He raises the bipod legs and rotates them 180 degrees. He spreads the bipod legs until they are fully extended, and the spread chain is taut. Once the bipod is placed on the ground, the assistant gunner tightens the cross-level locking knob.
- g. With the gunner standing on the left and the second ammunition bearer on the right, they grasp the traversing mechanism and bipod legs. With the assistant

gunner holding the bipod legs just above the spread chain, they pull and guide the barrel forward away from the trailer. The assistant gunner guides the bipod legs to a point (about 2 feet) in front of the baseplate and lowers them to the ground. At this point, the mortar is free from the trailer.

h. The first ammunition bearer moves the trailer to the point selected by the squad leader away from the mortar position.

i. The gunner unlocks the clamp handle assembly. The gunner, who is now standing to the rear and straddling the barrel, grasps under the recoil buffer assembly and pulls down, sliding the barrel clamp down the barrel until it rests against the lower collar stop.

j. The gunner makes sure the white lines on the barrel and the buffer housing assembly are aligned. He retightens the clamp handle assembly until it "clicks." Then, he places the selector switch on FIRE (F). The assistant gunner checks for slack in the spreader chain and ensures the traversing mechanism is within four turns from center of traverse. The assistant gunner also ensures the traversing extension is locked in the center position and the cross-leveling locking knob is hand tight.

Note: Part of the white line on the buffer housing assembly must overlap the white line on the barrel.

k. The gunner removes the sight from the sight box and indexes a deflection of 3200 mils and an elevation of 1100 mils on the sight. He places the sight in the dovetail slot of the bipod. The gunner and assistant gunner then level the mortar for elevation and deflection. When the gunner is satisfied with the lay of the mortar, he announces, "Gun up." The mortar is now mounted and ready to be reciprocally laid.

7-9. PERFORMING SAFETY CHECKS ON A GROUND-MOUNTED 120-mm MORTAR

Specific safety checks must be performed before firing mortars. Most can be made visually. The gunner is responsible for physically performing the checks under the squad leader's supervision.

a. The gunner checks for mask and overhead clearance.

(1) To determine mask clearance, the gunner lowers the barrel to 0800 mils elevation. He places his head near the base of the barrel and sights along the top of the barrel for obstructions through the full range of traverse.

(2) To determine overhead clearance, the gunner raises the barrel to 1500 mils elevation. He places his head near the base of the barrel and sights along the top of the barrel for obstructions through the full range of traverse.

Note: If at any point in the full range of traverse, both at minimum or maximum elevation, an obstruction is found, the gunner raises or lowers the barrel until the round will clear the obstruction when fired. He turns the sight elevation micrometer knob until the elevation bubble is level. He reads the elevation at this point and reports the deflection and elevation to the squad leader who, in turn, reports this information to the FDC.

b. The gunner ensures the barrel is locked to the baseplate.

(1) He locks the barrel onto the socket of the baseplate with the white line on the barrel facing up.

(2) He aligns the white line on the barrel with the white line on the clamp handle assembly.

c. The gunner checks the buffer housing assembly to ensure that it is locked. He checks this by loosening the clamp handle assembly about 1/4 of a turn and retightening it until a metallic click is heard.

d. The gunner checks the cross-leveling locking knob to ensure it is hand tight.

e. The gunner checks the spreader chain to ensure that it is taut.

f. The gunner checks the firing selector to ensure it is in the FIRE position with the "F" showing.

7-10. PERFORMING SMALL DEFLECTION AND ELEVATION CHANGES ON A GROUND-MOUNTED 120-mm MORTAR

The gunner receives deflection and elevation changes from the FDC in the form of a fire command. If a deflection change is required, it precedes the elevation change.

Note: Small deflection and elevation changes are greater than 20 mils but less than 60 mils for deflection and greater than 35 mils but less than 90 mils for elevation.

a. The gunner sets the sight for deflection and elevation.

(1) He places the deflection on the sight by turning the deflection micrometer knob until the correct 100-mil deflection mark is indexed on the coarse deflection scale. He continues to turn the deflection micrometer

knob until the remainder of the deflection is indexed on the deflection micrometer scale.

(2) The gunner places the elevation on the sight by turning the elevation micrometer knob until the correct 100-mil elevation mark is indexed on the coarse elevation scale. He continues to turn the elevation micrometer knob until the remainder of the elevation is indexed on the micrometer scale.

b. The gunner lays the mortar for deflection.

(1) After the deflection and elevation are indexed on the sight, the gunner floats the elevation bubble.

(2) He turns the elevating hand crank to elevate or depress the mortar until the bubble in the elevation level vial starts to move. This initially rough lays the mortar for elevation.

(3) After rough laying the mortar for elevation, the gunner looks through the sight and traverses to realign on the aiming post. He traverses half the distance to the aiming post, then cross-levels.

(4) Once the vertical cross line is near the aiming posts (about 20 mils), the gunner checks the elevation vial. If required, he re-lays for elevation by elevating or depressing the elevating mechanism. He makes final adjustments using the traversing handwheel and cross-levels by traversing half the distance and cross-leveling.

(5) When the vertical cross line is within 2 mils of the aiming posts, all bubbles are leveled, and the sight is set on a given deflection, the mortar is laid.

Note: If the given deflection exceeds left or right traverse, the gunner may choose to use the traversing extension assembly. This gives him an added number of mils in additional traverse to avoid moving the bipod. To use the traversing extension, the gunner pulls down on the traversing extension locking knob and shifts the cannon left or right. He re-locks the traversing extension locking knob by ensuring it is securely seated.

7-11. PERFORMING LARGE DEFLECTION AND ELEVATION CHANGES ON A GROUND-MOUNTED 120-mm MORTAR

The gunner receives deflection and elevation changes from the FDC in the form of a fire command. If a deflection change is required, it will always precede the elevation change. The gunner lays the mortar for a large deflection and elevation change.

Note: Large deflection and elevation changes are greater than 200 mils but less than 300 mils for deflection and greater than 100 mils but less than 200 mils for elevation.

a. The gunner receives a deflection and elevation change in the form of an initial fire command.

Note: All elements of the fire command are repeated by the gun squad.

b. As soon as the gunner receives the data, he places it on the sight and elevates or depresses the mortar to float the elevation bubble.

c. The assistant gunner positions himself in front of the bipod. He squats slightly with his legs spread shoulder-width apart and supports his elbows on his knees. He grabs the bipod legs and lifts them until the bipod clears the ground.

d. The gunner moves the mortar by placing his right hand over the clamp handle assembly and his left hand on the bipod leg. He pushes or pulls the bipod in the direction desired until the vertical cross line is within 20 mils of the aiming posts. Once completed, the gunner directs the assistant gunner to lower the bipod. He then floats the deflection bubble and looks into the sight to see if he is within 20 mils of his aiming posts.

e. The gunner and assistant gunner level the mortar for elevation. If after leveling the mortar for elevation, the vertical cross line of the M67 sight is within 20 mils of the aiming post, he would then center the deflection bubble and take up the proper sight picture by traversing half the distance to the aiming posts and cross-leveling.

f. The assistant gunner observes the gunner traversing to ensure that he stays within four turns of center-of-traverse. Should the gunner traverse away from center-of-traverse, the assistant gunner advises and instructs the gunner to center back up. The gunner center traverses, and with the help of the assistant gunner, he shifts the bipod again and repeats steps **c** through **e**.

Note: After leveling the mortar, if the vertical cross line of the M67 sight is not within 20 mils of the aiming post, then steps **c** through **e** are repeated.

g. The gunner makes minor adjustments as necessary and does a final check of the bubbles and center-of-traverse, and announces, "Up."

7-12. MALFUNCTIONS ON A GROUND-MOUNTED 120-mm MORTAR

See Chapter 3, paragraph 3-14 for a detailed discussion of malfunctions.

7-13. PERFORMING MISFIRE PROCEDURES ON A GROUND-MOUNTED 120-mm MORTAR DURING COMBAT

The barrel assembly of the towed 120-mm mortar must be at its lowest elevation to perform the misfire procedures. When a misfire occurs, all crew members, or the crew member that first notices, shout, "MISFIRE."

WARNING

To avoid possible injury to the crew, do not stand in front of or behind the barrel.

a. At the announcement of a misfire, all crew members remain with the mortar.

Note: During peacetime live-fire exercises, all crew members except the gunner will leave the firing position and move at least 100 meters to the rear of the mortar position.

b. The gunner stands to the left rear of the mortar and kicks the barrel several times. If the round does not fire, the gunner waits for one minute. (This allows the round to fire if there is a delayed action [hang fire] of the propelling charge.) After the one-minute wait, the gunner performs the following:

(1) He checks the barrel for heat using his bare hands. Starting at the muzzle, he lightly touches the barrel with his fingertips every few inches down to the breech cap. If the barrel is too hot, the crew uses some means (such as water or snow) to cool it down before attempting to remove the misfire.

(2) If the barrel is cool enough to handle, the gunner places the weapon on SAFE with the "S" showing.

c. The gunner locks the data down on the sight unit, removes the sight and places it in a safe place (sight box), and calls the crew forward.

d. The gunner then depresses the barrel to its lowest elevation using the elevation handwheel, leaving about a quarter inch of sleeve showing (so there is no metal to metal contact).

CAUTION

At no time will the clamp handle assembly be loosened (except during jammed or stuck rounds).

e. The assistant gunner secures the staff assembly with the extractor attached. He rotates it forward, stabilizing the extractor, and inserts the extractor into the cannon. He lowers it slowly into the cannon (hand over hand) until the extractor makes contact with the round. He rotates the extractor in either direction until he feels the detent pins connect into the round. He continues rotating until resistance is felt.

f. The assistant gunner lifts up slightly on the extractor to ensure it has connected with the round. He continues lifting the extractor until the body of the round appears at the muzzle. At this time, the gunner grasps the round and assists in removing the round. Together they move to the right of side of the weapon.

Note: Due to the weight of the round, the gunner may assist during the entire extraction process.

CAUTION

Once the assistant gunner ensures the extractor is firmly connected with the round, he extracts the round in one steady motion (using the hand-over-hand process) without stopping or lowering the round.

Note: If the round is jammed or stuck and cannot be removed by the extractor, the gunner holds the barrel and unlocks the clamp handle assembly while the assistant gunner stabilizes the bipod. The first ammunition bearer grasps the base of the cannon and rotates the it until the white line is in the down position while the gunner lifts the cannon to release it from the baseplate. The assistant gunner moves the bipod to the right and out of the way. The gunner and first ammunition bearer lift the cannon to a horizontal position and carry it, with the extractor in place, to the dud pit. Ensuring the cannon remains pointed down range, the platoon leader or platoon sergeant notifies EOD personnel.

g. The gunner stands to the left side of the weapon in the gunner's position. He holds his hands ready near the muzzle to grasp the round as soon as the body of the round clears the muzzle. The assistant gunner and gunner then complete removing the round from the barrel. Once the round has cleared the barrel, both crew members move to the right of the mortar position. The ammunition bearer comes forward and stands beside the gunner.

h. With the assistant gunner holding the round extractor by the handle and the gunner holding the round, the ammunition bearer presses on all four catches on the extractor at the same time, releasing the round from the extractor.

i. The gunner inspects the round. If the primer has been struck by the firing pin, the round is disposed of in accordance with range SOP. If no contact was made

with the firing pin, action is taken to clean any possible obstructions inside the barrel.

Note: Nondevelopment item (NDI) ammunition will not be refired.

j. The assistant gunner swabs the bore and the gunner places the safety mechanism on "F" (FIRE).

k. The gunner re-installs the sight, re-lays the mortar, and continues the mission.

Note: If the extractor cannot grasp the round, use another extractor if possible. If the extractor still cannot grasp the round, follow steps **l** through **q**.

l. The gunner holds the cannon near the muzzle and the assistant gunner holds the bipod assembly. The gunner opens the buffer housing assembly.

m. The gunner and ammunition bearer turn the cannon until the white line is in the down position and carefully remove the cannon from the breech cap socket.

n. Keeping the cannon horizontal and pointing in the direction of fire, the gunner and ammunition bearer move the cannon to the opposite side of the ammunition point. The assistant gunner places the ends of his thumbs over the edges of the muzzle, grasping the cannon with his fingers.

o. At the assistant gunner's command of LIFT, the ammunition bearer lifts the cannon's breech cap assembly causing the round to slide down to the assistant gunner's hands. The assistant gunner removes the round, inspects it, tries to replace the safety wire (if applicable), places the round in the dud pit, tags the round, and notifies EOD.

p. The assistant gunner swabs the bore.

q. The gunner re-lays the mortar and continues the mission.

Note: If the round is grasped but cannot be removed, follow steps **r** through **t**.

r. The gunner holds the cannon near the muzzle, and the assistant gunner holds the bipod assembly. The gunner opens the buffer housing assembly.

s. The gunner and ammunition bearer turn the cannon until the white line is in the down position and carefully remove the cannon from the breech cap socket.

t. Keeping the cannon horizontal and pointing in the direction of fire, the gunner and ammunition bearer lift the cannon (with the extractor still attached to the

round) and carry it to the dud pit, ensuring it remains pointing downrange. The platoon leader or platoon sergeant notifies EOD.

7-14. LOADING AND FIRING THE GROUND-MOUNTED 120-mm MORTAR

The following paragraphs explain the procedures for loading and firing a ground-mounted 120-mm mortar.

- a. The FDC issues a fire command to the squad leader.
- b. The squad leader records and issues the fire command to the squad.
- c. The squad repeats the fire commands.
- d. The ammunition bearer(s) prepares the round(s) IAW the fire command.
- e. The ammunition bearer prepares the round so that the squad leader can inspect it before it is passed to the assistant gunner. The ammunition bearer holds the round with both hands (palms up) near each end of the round body (not on the fuze or the charges).
- f. The assistant gunner checks the round for correct charges, fuze tightness, and fuze setting.
- g. When both the gun and the round(s) have been determined safe and ready to fire, the squad leader gives the following command to the FDC: NUMBER (NUMBER OF MORTAR) GUN, UP.
- h. The ammunition bearer holds the round with the fuze pointed to his left. By pivoting his body to the left, the assistant gunner accepts the round from the ammunition bearer with his right hand under the round and his left hand on top of the round.
- i. Once the assistant gunner has the round, he keeps two hands on it until it is fired.

CAUTION

The assistant gunner is the only member of the mortar squad who loads and fires the round.

- j. The squad leader commands, HANG IT, FIRE in accordance with the method of fire given by the FDC.

- k. The assistant gunner holds the round out in front of the muzzle at about the same angle as the cannon. At the command, HANG IT, the assistant gunner guides the round into the barrel (tail end first) to a point beyond the narrow portion of the body (about three-quarters of the round) being careful not to hit the primer or charges or disturb the lay of the mortar.
- l. Once the round is inserted into the barrel the proper distance, the assistant gunner shouts, "Number (number of mortar) gun, hanging."
- m. At the command, FIRE, the assistant gunner releases the round by pulling both hands down and away from the outside of the barrel. The assistant gunner ensures that he does not take his hands across the muzzle of the cannon as he drops the round.
- n. Once the round is released, the gunner and assistant gunner take a full step toward the rear of the weapon while pivoting their bodies so that they are both facing away from the blast.
- o. The assistant gunner pivots to his left and down toward the ammunition bearer and is now ready to accept the next round to be fired (only if there are no major movements of the bipod in which he is required to lift and clear the bipod off the ground).
- p. Subsequent rounds are fired based on the FDC fire commands.
- q. The assistant gunner ensures the round has fired safely before he attempts to load the next round.
- r. The assistant gunner does not shove or push the round down the barrel. The round slides down the barrel under its own weight, strikes the firing pin, ignites, and fires.
- s. The assistant gunner and gunner, as well as the remainder of the mortar crew, keep their upper body below the muzzle until the round fires to avoid muzzle blast.
- t. During an FFE, the gunner tries to level all bubbles between each round ensuring his upper body is away from the mortar and below the muzzle when the assistant gunner announces, "Hanging," for each round fired.
- u. The assistant gunner informs the squad leader when all rounds for the fire mission are expended, and the squad leader informs the FDC when all of the rounds are completed. For example, "NUMBER TWO GUN, ALL ROUNDS COMPLETE."

7-15. TAKING THE 120-mm MORTAR OUT OF ACTION

To take the 120-mm mortar out of action, the squad leader commands, OUT OF ACTION. Then, each member of the squad does the following:

- a. The gunner places the weapon on SAFE with the "S" showing.
- b. The second ammunition bearer retrieves the aiming posts, places them in their case, and puts the case on the right side of the mortar.
- c. The gunner places a deflection of 3800 mils and an elevation of 0800 mils on the sight.
- d. The gunner removes the sight from the dovetail slot and places it in the sight case. He places the sight mount cover back on and secures it with the snap button.

Note: Left and right are in relation to the mortar's direction of fire.

- e. The gunner loosens the clamp handle assembly.
- f. The gunner slides the buffer housing assembly up the barrel until it is aligned with the white line on the cannon near the muzzle. The white line on the barrel must match with the white line on the clamp handle assembly. The gunner tightens the buffer housing assembly until he hears a metallic click. He continues turning the handle until it is parallel to the barrel.
- g. The gunner centers the traversing extension and the traversing mechanism.
- h. The gunner lowers the elevation so that about four fingers (three to four inches) of the elevating mechanism remains exposed.
- i. The assistant gunner loosens the cross-level locking knob while the gunner steadies the barrel.
- j. The first ammunition bearer positions himself to the right side of the trailer. He positions the trailer behind the baseplate with the towing eye almost straight up. The second ammunition bearer assists when he has completed his task of retrieving the aiming posts.
- k. The first ammunition bearer holds the trailer in place with the barrel cradle touching the top of the breech cap. He blocks the wheels so that the trailer cannot roll.
- l. The second ammunition bearer releases the clamping catch on the trailer bridge assembly and swings the bridge assembly out of the way.

- m. The gunner and the second ammunition bearer grasp the traversing mechanism and bipod legs, then swing the barrel and bipod over the baseplate and onto the trailer. The assistant gunner loosens the cross-leveling locking knob and assists in raising the bipod legs, then joins the legs and rotates them 180 degrees.
- n. With the trailer still in the upright position, the first ammunition bearer makes sure that the upper collar stop is placed just forward of the upper barrel bracket on the trailer.
- o. The assistant gunner holds and lifts the baseplate onto the trailer as the first ammunition bearer returns the trailer to the towing position, lifting the entire mortar onto the trailer.
- p. The gunner attaches the hook on the spreader chain to the eye on the bipod leg. He adjusts the elevation so that the bipod legs fit under the trailer bridge assembly and retightens the locking knob.
- q. The assistant gunner closes the trailer bridge assembly. He locks the baseplate with the lock release lever and secures it with the pin. He then secures the trailer bridge assembly with the clamping catch.
- r. The first ammunition bearer replaces the muzzle cap.
- s. The first ammunition bearer moves to the driver's side of the towing eye. The second ammunition bearer moves to the passenger's side of the towing eye. Together, they move the trailer to the vehicle and hook the trailer to the towing pintle of the vehicle. They hook up the trailer light cable and safety chains.
- t. The gunner secures the sight case.
- u. The assistant gunner secures the aiming post case.
- v. The squad leader inspects to ensure all equipment is accounted for and properly secured.
- w. The squad leader announces, "Number two gun, up."

Section IV. MORTAR CARRIER, M1064A3

This section is a guide for training mortar units equipped with the M1064A3-series mortar carrier for mounting the M121 mortar. The procedures and techniques used for a mounted mortar are different from the ground-mounted mortar.

7-16. DESCRIPTION

The M1064A3 carrier (Figures 7-7 and 7-8) is an M113A3 armored-personnel carrier modified to carry the 120-mm mortar, M121, on a specially designed mount. It is fully tracked, highly mobile, and armor protected. It can be transported by air and can be dropped, and it has fording capabilities in up to 40 inches of water.

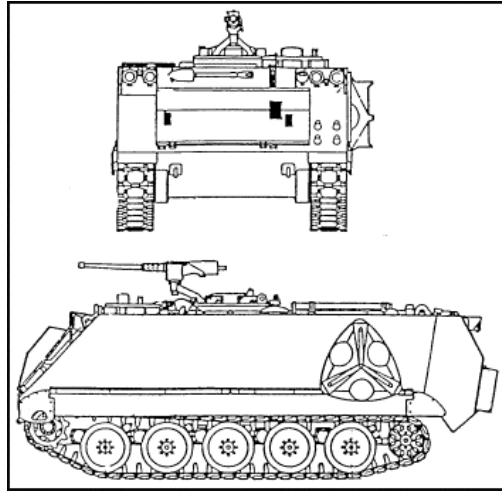

Figure 7-7. Mortar carrier M1064A3, front and side view.

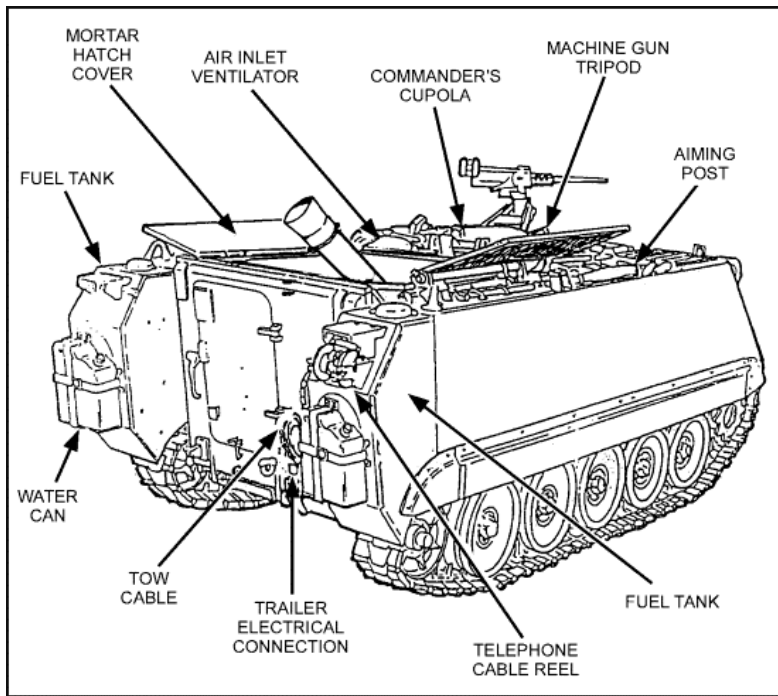

Figure 7-8. Mortar carrier M1064A3, rear view.

7-17. TABULATED DATA FOR THE M1064A3 CARRIER

Table 7-2 shows the tabulated data for the M1064A3 carrier and the mortar capabilities when mounted on a turntable.

GENERAL	
Weight	
Combat loaded	28,240 pounds
Air transportable	23,360 pounds
Ground pressure, combat loaded	8.97 psi
Personnel capacity	4
Fuel tank capacity	95 gallons
PERFORMANCE	
Speed on land	40 mph

Speed in water, with track	3.6 mph
Cruising range	300 miles
Turning radius	Pivot to infinite
Slope	60 percent
Side slope	40 percent
Trench crossing	66 inches
Vertical wall climbing	24 inches
Gross horsepower-to-weight ratio	19.5 hp/ton
ENGINE	
Make and model	Detroit diesel 6V53T
Displacement	318 cubic inches
Fuel	Diesel
Gross horsepower	275
TRANSMISSION, AUTOMATIC	
Make and model	Allison X200-4A
Type	Hydrokinetic
Steering	Hydrostatic
Brake type	Multiple wet plate
RUNNING GEAR	
Suspension type	Torsion bar
Road wheels	5 pairs per side, 24-inch diameter
Track type	Steel single pin, detachable rubber pad
Number of shoes	
Track pitch	63 left, 64 right
Track width	6 inches
Shock absorbers	15 inches
Wheel travel	3 per side 9.0 inches
ELECTRICAL SYSTEM	
Generator	200
Amperes	28
Volts, dc	4 type 6TL, 120 amp/hr, 12 volts each
Batteries	
ARMAMENT	
.50 caliber machine gun	2,000 ready rounds
120-mm mortar	69 ready rounds (45 horizontal, 24 vertical). Type of rounds carried depends on the tactical mission.

SQUAD WEAPONS	
Rifles, M16A2, 5.56-mm	4
ARMOR	
Hull	5083 Aluminum
FIRE EXTINGUISHERS	
Fixed	5 pounds CO ₂ for engine
Portable	compartment 5 pounds CO ₂
MORTAR CAPABILITIES MOUNTED ON TURNTABLE	
TRAVERSING LIMITS	
Right of center with traverse extension	858 mils
Left of center with traverse extension	808 mils
TOTAL TRAVERSE	
Capability from extreme left to extreme right	1486 mils 1666 mils
Without traversing extension	
With traversing extension	
ELEVATION LIMITS (LEVEL)	
Track maximum	1510 mils
Track minimum	0800 mils

Table 7-2. Tabulated data for the M1064A3 carrier .

Section V. OPERATION OF A CARRIER-MOUNTED 120-mm MORTAR

The mortar section is the fire unit for the mortar platoon. When a position is occupied, mortars are emplaced 75 meters apart making the section front (distance between flank mortars) about 150 meters. The mortars are numbered 1, 2, and 3 (from right to left) when facing the direction of fire. The squad of the mortar carrier consists of four members--squad leader, gunner, assistant gunner, ammunition bearer/driver. The differences in the procedures from a ground-mounted mortar squad are also discussed in this section.

7-18. MORTAR AND VEHICULAR MOUNT

The mortar is carried while attached to its vehicular mount. A clamping support is provided to hold the mortar during travel. A bipod support assembly provides attachment mounting for the M191 bipod and secures it in a locking position during travel. The

breech socket provides a base in which the weapon rests. The mortar is provided with a sight extension arm assembly, which is received by the socket of the coupling and sight mount assembly. The gunner uses the sight extension arm to sight on his aiming point above the hull of the vehicle. The extension must be removed before moving the mortar to prevent wear on the sight mount's coupling gears.

7-19. MAINTENANCE

Care and cleaning of the mortar, instruments, and equipment are the duty and responsibility of the mortar squad. Care and cleaning of the carrier-mounted mortar are the same as for the ground-mounted mortar. All maintenance records and lubricating procedures for the 120-mm mortar and the mount, M191, are located in TM 9-1015-250-10. For maintenance procedures for the M1064A3 carrier, see TM 9-2350-261-10.

7-20. PLACING A CARRIER-MOUNTED 120-mm MORTAR INTO ACTION

To place the mortar into action, the crew performs the following actions upon the squad leader's command, ACTION.

Note: If the weapon system cannot be leveled at any elevation given, the gunner is authorized to go to high range (low range) and move the buffer housing assembly along the cannon between the circular white line and the lower collar stop without moving past the vertical position until the gun system can be leveled.

- a. The gunner pulls the chain on the center cargo hatch releasing and folding it over onto the right hatch ensuring that the hatch locks into place. He then pulls the chain on the right cargo hatch releasing and folding it over and secures it.
- b. Once the gunner has the center and right cargo hatch secured, the assistant gunner pulls the chain on the left cargo hatch releasing and folding the hatch over ensuring that it is locked into place.
- c. The assistant gunner unlocks the clamping support assembly.
- d. The gunner loosens the clamp handle assembly and grasps the buffer housing assembly and pulls it down until it is flush with the lower collar stop.
- e. The gunner ensures the white line on the barrel is lined up with the white line on the buffer housing assembly. He then tightens the clamp handle assembly until a metallic click is heard. He places the weapon on FIRE with the "F" showing.
- f. The assistant gunner then passes the sight extension to the gunner and removes the muzzle cover.

- g. The gunner places the sight extension into the dovetail slot on the bipod and secures it.
- h. The gunner mounts the sight onto the sight extension and places a deflection of 3200 mils and an elevation of 1100 mils onto the sight and levels the deflection bubble with the cross-leveling handwheel on the bipod.
- i. The assistant gunner places the BAD onto the cannon and secures it and levels the elevation bubble.
- j. The gunner then ensures that the traversing mechanism is within four turns of center, and the traversing extension is centered on the bipod.
- k. When the gunner is satisfied that the mortar is mounted correctly, he announces, "Up" so that the squad leader can inspect the weapon system.
- l. The carrier-mounted 120-mm mortar is now placed into action and ready to be reciprocally laid.

7-21. LAY FOR DEFLECTION AND ELEVATION ON A CARRIER-MOUNTED 120-mm MORTAR

Deflection and elevation are received from the fire direction center in the form of a fire command. If a deflection change is required, it will always precede the elevation change.

Note: Small deflection changes are greater than 20 mils but less than 60 mils. Small elevation changes are greater than 35 mils but less than 90 mils. Large deflection changes are greater than 200 mils but less than 300 mils. Large elevation changes are greater than 100 mils but less than 200 mils.

a. *Small Deflection and Elevation Changes.*

- (1) The gunner is given a deflection and elevation change in the form of a fire command.
- (2) As soon as the gunner receives the fire command, he places the data on the sight and elevates or depresses the mortar to "float" the elevation bubble.
- (3) The gunner then looks into the sight to determine whether to traverse the mortar. He places his hand on the traversing handwheel and traverses one-half the distance to his aiming poles.
- (4) The gunner cross-levels his deflection bubble with the cross-level handwheel on the bipod.

(5) The gunner repeats steps (3) and (4) until the vertical cross line is within 2 mils of the left edge of the aiming posts and his deflection bubble is leveled.

(6) The gunner levels his elevation bubble with the elevation handwheel on the bipod.

(7) The gunner rechecks his data and bubbles to ensure the proper lay of the weapon system.

b. Large Deflection and Elevation Changes.

(1) The deflection and elevation are received from the FDC in the form of a fire command. If a deflection change is required, it precedes the elevation change.

Note: Large deflection changes are greater than 200 mils but less than 3000 mils. Large elevation changes are greater than 100 mils but less than 200 mils. This may require the buffer housing assembly to be moved up on the cannon. Ensure the bipod is not forward of the vertical position.

(2) Lay for large deflection and elevation change.

(a) The mortar is mounted and the sight is laid on the aiming posts with a deflection and an elevation.

(b) The gunner is given a deflection and an elevation change in the form of a fire command.

(c) As soon as the gunner receives the fire command, he places the data on the sight, and elevates or depresses the mortar to "float" the elevation bubble. The assistant gunner is allowed to "dead level" the elevation bubble.

(d) If in low range, the gunner unlocks the low-range support latch. With his left hand on the bipod leg and his right hand on the traversing mechanism, and with the assistant gunner's right hand on the bipod leg and his left hand on the traversing mechanism, together they raise the bipod into high range.

(e) The assistant gunner inserts the high-range locking pin to secure the bipod.

(f) If in high range, the gunner pulls the high-range locking pin. With his left hand on the bipod leg and his right hand on the traversing mechanism,

and with the assistant gunner's right hand on the bipod leg and his left hand on the traversing mechanism, together they lower the bipod into low range.

(g) The gunner then looks into his sight to determine if he has to shift the mortar and announces to the assistant gunner, "Unlock the turntable."

(h) With the assistant gunner's help, the gunner looks through his sight and shifts the mortar until the vertical cross line is aligned with the aiming poles.

(i) The gunner cross-levels his deflection bubble. Once leveled, he looks into the sight to determine if he is still within 20 mils of his aiming posts. If the vertical cross line is still within 20 mils of the aiming posts, the gunner announces to the assistant gunner, "Lock it" (referring to locking the turntable).

(j) With the turntable in the locked position, the gunner continues to traverse and cross-level until the vertical cross line is lined up with the aiming posts, and the deflection bubble is level.

(k) The gunner levels the elevation bubble. Before the gunner announces, "Gun up," he rechecks his data, bubbles, and four turns of center.

(3) When the mortar is traversed more than 60 mils left or right from center, a compensated sight picture occurs. To correct this, the rule to follow is "hey-diddle-diddle-far-pole-in-the-middle."

7-22. PERFORMING MISFIRE PROCEDURES ON AN M121 CARRIER-MOUNTED 120-mm MORTAR DURING COMBAT

The barrel assembly of the carrier-mounted 120-mm mortar must be at its lowest elevation to perform misfire procedures. However, crews must never change from high range to low range. When a misfire occurs, all crew members (or the crew member that first notices) shout, "Misfire."

WARNING

To avoid possible injury to the crew, do not change the range of the mortar (from high to low or from low to high). Do not stand in front of or behind the barrel.

a. At the announcement of "Misfire," all crew members remain with the mortar.

Note: During peacetime live-fire exercises, all crew members except the gunner leave the firing position and move at least 100 meters to the rear of the mortar position. All crew members will exit the carrier through the cargo hatches, climbing over the front of the carrier, and will return the same way.

b. The gunner stands to the right or left rear of the mortar and kicks the barrel several times. If the round does not fire after kicking the barrel, the gunner moves to where the rest of the crew is and waits for one minute. (This 1-minute wait allows the round time to fire should there be a delayed action [hangfire] of the propelling charge.) After the 1-minute wait, the gunner performs the following:

(1) He checks the barrel for heat using his bare hands. Starting at the muzzle, he lightly touches the barrel with his fingertips every few inches down to the breech cap. If the barrel is too hot, the crew uses some means (such as water or snow) to cool it down before attempting to remove the misfire.

(2) If the barrel is cool enough to handle, the gunner places the weapon on SAFE with the "S" showing.

c. The gunner locks the data down on the sight unit, removes the sight and places it in a safe place, and calls the crew forward.

d. The driver/ammunition bearer mounts the carrier from the front and lowers the ramp.

e. The gunner then depresses the barrel to its lowest elevation using the elevation handwheel, leaving about 1/4 inch of sleeve showing (so there is no metal to metal contact).

CAUTION

At no time will the clamp handle assembly be loosened (except during jammed or stuck rounds).

f. The assistant gunner removes the blast attenuator device and places it aside. He secures the staff assembly with the extractor attached. He rotates it forward, stabilizing the extractor, and inserts the extractor into the cannon. He lowers it slowly into the cannon (hand over hand) until the extractor makes contact with the round. He rotates the extractor in either direction until he feels the detent pins connect into the round. He continues rotating until resistance is felt.

g. The assistant gunner lifts up slightly on the extractor to ensure it has connected with the round. He continues lifting the extractor until the body of the round

appears at the muzzle. At this time, the gunner grasps the round and assists in removing the round. Once the round has cleared the cannon, the extractor with staff assembly and round is guided between the cannon and the cross-member. The gunner and assistant gunner move under the cross-member and down the ramp to the opposite side of the ammunition point at the rear of the carrier.

Note: Due to the weight of the round, the gunner may assist during the entire extraction process.

CAUTION

Once the assistant gunner ensures the extractor is firmly connected with the round, he extracts the round in one steady motion (using the hand-over-hand process) without stopping or lowering the round.

Note: If the round cannot be removed with the extractor, the assistant gunner kneels on the ramp to stabilize the bipod. The gunner places his left hand under the cannon and loosens the clamp assembly until the buffer housing assembly falls free from the cannon. The assistant gunner lowers the bipod to the ramp. The gunner and ammunition bearer lift the cannon to approximately a 60-degree angle and rotate the cannon until the white line is on the bottom. Together, they lift the cannon from the breech socket assembly and carry it to the dud pit. Ensuring the cannon remains pointed down range, the platoon leader or platoon sergeant notifies EOD personnel. (At no time will the cannon be lifted over or rested on the carrier's cross-member. The cannon **MUST** be taken under the cross-member.)

h. Once the gunner and assistant gunner have cleared the ramp, the ammunition bearer comes forward and stands beside the gunner.

i. With the assistant gunner holding the round extractor by the handle and the gunner holding the round, the ammunition bearer presses on all four catches on the extractor at the same time, releasing the round from the extractor.

j. The gunner inspects the round. If the primer has been struck by the firing pin, the round is disposed of in accordance with range SOP. If no contact was made with the firing pin, action is taken to clean any possible obstructions inside the barrel.

Note: Nondevelopment item (NDI) ammunition will not be refired.

k. The assistant gunner swabs the bore and the gunner places the safety mechanism on "F" (FIRE).

l. The gunner re-installs the sight, re-lays the mortar, and continues the mission.

Note: If the extractor cannot grasp the round, use another extractor if possible. If the extractor still cannot grasp the round, follow steps **m** through **r**.

m. The gunner holds the cannon near the muzzle and the assistant gunner holds the bipod assembly. The gunner opens the buffer housing assembly.

n. The gunner and ammunition bearer turn the cannon until the white line is in the down position and carefully remove the cannon from the breech cap socket.

o. Keeping the cannon horizontal and pointing in the direction of fire, the gunner and ammunition bearer move the cannon to the opposite side of the ammunition point. The assistant gunner places the ends of his thumbs over the edges of the muzzle, grasping the cannon with his fingers.

p. At the assistant gunner's command of LIFT, the ammunition bearer lifts the cannon's breech cap assembly causing the round to slide down to the assistant gunner's hands. The assistant gunner removes the round, inspects it, tries to replace the safety wire (if applicable), places the round in the dud pit, tags the round, and notifies EOD.

q. The assistant gunner swabs the bore.

r. The gunner re-lays the mortar and continues the mission.

Note: If the round is grasped but cannot be removed, follow steps **s** through **u**.

s. The gunner holds the cannon near the muzzle, and the assistant gunner holds the bipod assembly. The gunner opens the buffer housing assembly.

t. The gunner and ammunition bearer turn the cannon until the white line is in the down position and carefully remove the cannon from the breech cap socket.

u. Keeping the cannon horizontal and pointing in the direction of fire, the gunner and ammunition bearer lift the cannon (with the extractor still attached to the round) and carry it to the dud pit, ensuring it remains pointing downrange. The platoon leader or platoon sergeant notifies EOD.

7-23. MOUNTING OF THE MORTAR FROM A CARRIER TO A GROUND-MOUNTED POSITION

The procedures for placing the mortar into action by mounting it from a carrier to a ground-mounted position are described below.

Note: Left and right are in relation to the mortar's direction of fire.

- a. The driver lowers the ramp and dismounts the mortar from the carrier.
- b. The gunner pulls down on the chain for the center hatch and folds it over, then secures it to the right cargo hatch. He pulls down on the chain for the right cargo hatch and folds both hatches over, then secures them in place. The assistant gunner pulls down on the chain for the left cargo hatch and folds it over, then secures it in place.
- c. The squad leader dismounts the carrier and shows the crew where he wants the mortar to be mounted and indicates the direction of fire.
- d. The driver/ammunition bearer and assistant gunner release the baseplate by removing the safety pin and pushing the handle up. Together they tilt the baseplate out and lift it from the lower brackets.
- e. They place the baseplate at the firing position while the gunner retrieves the sight and aiming posts and places them on the left side of the baseplate.
- f. The assistant gunner holds the bipod while the gunner unlocks the clamp handle assembly. The assistant gunner lowers the bipod until it rests on the ramp. At the same time, the driver/ammunition bearer assembles the aiming posts.
- g. The assistant gunner releases the safety pins and rotates the handles until the arrows are facing each other and then pulls the handles out, releasing the bipod.
- h. The assistant gunner installs the bipod leg extensions onto the bipod and secures them with the safety pins.
- i. The assistant gunner and driver/ammunition bearer secure the bipod and carry it to the firing position. They place it about 2 feet in front of the baseplate.

CAUTION

Damage may occur to the turntable socket if the following procedures are not followed.

- j. The driver/ammunition bearer removes the muzzle plug while the gunner releases the clamping support assembly. Together they raise the barrel to a 60-degree angle and rotate it until the white line is facing the turntable. They then lift straight up removing the barrel from the socket.

k. The gunner and driver/ammunition bearer carry the barrel to the baseplate. With the white line on the barrel facing the ground, they tilt the barrel to a 60-degree angle. They carefully insert the barrel into the baseplate socket. They rotate the barrel until the white line is facing skyward and then lower it onto the buffer housing assembly ensuring the white line on the barrel aligns with the white line on the buffer housing assembly. The gunner then slides the buffer housing assembly down the barrel until it is flush with the lower collar stop on the barrel.

l. The gunner tightens the clamp handle assembly until a metallic click is heard.

m. The gunner places the safety mechanism on FIRE with the "F" showing.

n. The gunner places the sight on the weapon and indexes a deflection and elevation.

7-24. TAKING THE MORTAR OUT OF ACTION (GROUND-MOUNTED TO M1064A3 CARRIER-MOUNTED)

The procedures for mounting the mortar on the carrier from a ground-mounted position are described below.

a. The squad leader commands, OUT OF ACTION, PREPARE TO MARCH.

b. The gunner places the weapon on SAFE with the "S" showing.

c. The gunner places a deflection of 3200 mils and an elevation of 0800 mils on the M67 sight.

d. The gunner removes the sight from the dovetail slot. He places the sight in the sight case and secures it on the carrier.

e. The gunner then replaces the sight mount cover and snaps it.

f. The ammunition bearer retrieves the M14 aiming posts and the M58 and M59 aiming post lights and stows them on the carrier.

g. The assistant gunner kneels down and secures the bipod and lowers it to its lowest elevation leaving about one-quarter of a turn of the shaft showing.

h. The gunner opens the buffer housing assembly with his left hand while securing the barrel assembly with his right hand.

i. The gunner and ammunition bearer rotate the barrel assembly until the white line is on the bottom. They raise the barrel to about a 60-degree angle and lift it from the baseplate socket. They carry the barrel assembly to the carrier.

- j. The gunner and ammunition bearer make sure the clamping support assembly is open. They ensure the bipod support assembly is in the low-range position and the turntable is centered and locked.
- k. The gunner and ammunition bearer position the mortar barrel assembly just above the clamping support assembly with the white line facing down.
- l. The gunner and ammunition bearer carefully insert the breech cap ball into the socket. They raise the mortar barrel assembly and rotate it until the white line is in the up position. They install the muzzle plug and lower the mortar barrel assembly onto the clamping support assembly and lock it.
- m. The assistant gunner takes the bipod assembly to the carrier.
- n. The assistant gunner rests the bipod assembly on the carrier ramp with the cross-leveling mechanism pointing toward the gunner's position.
- o. The assistant gunner removes pins and leg extensions from the bipod legs and stows them in the step.
- p. The assistant gunner removes the handles from the bipod support assembly. He ensures the arrows are facing each other.
- q. The assistant gunner slides the bipod legs onto the attaching slot on the bipod support assembly.
- r. With the arrows facing each other and the holes matching, the assistant gunner inserts the handles through the bipod support assembly slot and legs. He turns the handles so that the arrows point toward the bipod legs and attaches the safety pins.
- s. The assistant gunner slides the buffer housing assembly up along the barrel assembly until it stops. He tightens the clamp handle assembly until he hears a metallic click.
- t. The assistant gunner and ammunition bearer carry the baseplate to the carrier,
- u. The assistant gunner and ammunition bearer make sure the pin is removed and the handle is up.
- v. The assistant gunner and ammunition bearer lift the baseplate with the spades away from the carrier and place the two corners without handles inside the rims of the lower brackets.
- w. The assistant gunner and ammunition bearer tilt the baseplate toward the carrier and pull the handle down and lock it with the pin.

x. The squad leader inspects to ensure all equipment is accounted for and properly secured.

y. The squad leader announces, "Number two gun up and prepared for march."

7-25. PERFORMING SAFETY CHECKS ON A CARRIER-MOUNTED 120-mm MORTAR

Specific safety checks must be performed before firing mortars. Most can be made visually. The gunner is responsible for physically performing the checks under the squad leader's supervision.

Note: The buffer housing assembly may need to be adjusted to complete this task.

a. The gunner checks for mask and overhead clearance.

(1) To determine mask clearance, the gunner places an elevation of 0800 on the sight and lowers the barrel until the elevation bubble is level. He places his head against the breech cap and sights along the barrel to see if any obstructions are in front of the mortars. With the gunner's head still against the breech cap, the assistant gunner traverses the mortar through its full range of traverse (traversing extension) to ensure that no obstructions are in front of the mortar.

(2) To determine overhead clearance, the gunner places an elevation of 1500 on the sight and raises the barrel until the elevation bubble is level. He places his head against the breech cap and sights along the barrel to see if any obstructions are in front of the mortar. With the gunner's head still against the breech cap, the assistant gunner moves the mortar through its full range of traverse (traversing extension) to ensure that no obstructions are in front of the mortar.

Note: If obstructions are found at any point in the full range of traverse or elevation, then the mortar is not safe to fire. (In a combat situation, it may be necessary to fire the mortar from that position; if this is the situation, traverse and or elevate the mortar until it clears the obstruction. Level the sight by using the elevation micrometer knob. *Record the deflection and elevation where the mortar clears the obstruction and report this information to the FDC.*)

b. The gunner checks to ensure the breech assembly is locked in the turntable socket and the white line on the cannon bisects the white line on the buffer housing assembly.

c. The gunner checks to ensure the M191 bipod assembly is locked to the turntable mount and the arrows on the mount handles are pointed down (vertical).

- d. The gunner checks to ensure the safety pins are installed,
- e. The gunner ensures that the buffer housing assembly is secured to the cannon by loosening the clamp handle assembly about one-quarter of a turn and tightening the clamp handle assembly until a metallic click is heard.
- f. The gunner ensures the cross-leveling locking knob is hand tightened.
- g. The gunner checks the bipod support assembly to ensure it is locked in the high or low position and the safety pin is installed.
- h. The gunner checks to ensure the turntable is in the locked position.
- i. The gunner checks to ensure the cargo hatches are open and locked.
- j. The gunner checks to ensure the blast attenuator device locking knob is hand tightened.
- k. The gunner checks to ensure the safety selector is in the FIRE position with the "F" showing.
- l. Ensure the bipod is not forward of the vertical position.

7-26. RECIPROCALLY LAYING THE MORTAR CARRIER SECTION

To reciprocally lay the mortar, follow the procedures discussed herein.

- a. The aiming circle (AC) operator lays the vertical cross line on the mortar sight and announces, "Aiming point this instrument."
- b. The gunner refers the sight (using the deflection micrometer knob) to the aiming circle with the vertical cross line, splitting the lens of the aiming circle, and announces, "Number (number of gun) gun, aiming point identified."
- c. The AC operator turns the azimuth micrometer knob of the aiming circle until the vertical cross lines are laid on the center of the gun sight lens. He reads the deflection micrometer scales and announces, "Number (number of gun) gun, deflection, two three one five (2315)."
- d. The gunner indexes the deflection announced by the AC operator on the sight and re-lays on the center of the AC lens by telling the driver to start the carrier. Looking through the sight, he tells the driver which direction to move the carrier (if necessary) and cross-levels. He ensures he has a correct sight picture (cross line splitting the AC lens), and the elevation and deflection bubbles are leveled. Once he has accomplished this, he announces, "Number (number of gun) gun, ready for recheck."

e. The AC operator gives the new deflection, and the process is repeated until the gunner announces, "Number (number of gun) gun, zero mils (or one mil); mortar laid."

f. As the squad announces, "Mortar laid," the AC operator commands the squad to give its referred deflection (normally 2800) and to place out aiming posts.

g. The gunner turns the deflection micrometer knob only and indexes a deflection of 2800 mils on his sight without disturbing the lay of the mortar.

h. The ammunition bearer runs with the aiming posts along the referred deflection about 100 meters from the mortar, dropping one post halfway (about 50 meters).

i. Once the far aiming post is placed out as described, the gunner uses arm-and-hand signals to guide the ammunition bearer to place out the near aiming post.

j. Once the correct sight picture is obtained, the gunner announces, "Number (number of gun) gun, up."

Section VI. AMMUNITION

Ammunition that can be fired by the 120-mm or 121-mm mortar are identified and described herein.

7-27. CLASSIFICATION

Ammunition is classified according to use. High explosive is used against personnel (in the open or in bunkers), light vehicles, and light bunkers. White phosphorus is used for screening and spotting. Illumination is used for battlefield illumination and signaling.

7-28. AUTHORIZED CARTRIDGES

The M929 smoke, M934 HE, and M933 HE cartridges are authorized to be fired from the M120 towed 120-mm mortar and the M121 carrier-mounted 120-mm mortar. The M57 HE, M91 illumination, and M68 smoke cartridges are authorized to be fired from a ground-mounted 120-mm mortar ONLY.

WARNING

Firing the M57, M68, or M91 120-mm cartridges from the M121 carrier-mounted mortar may cause bodily injury and hearing loss. These cartridges are not authorized to be fired from the carrier.

Note: 1. When using enhanced ammunition, the bursting area of the round is 75 meters:

when using NDI ammunition, the bursting area of the round is 60 meters.

2. A minimum range of 200 meters at charge 0 (charge may vary in firing table and whiz wheel) applies to all rounds and fuzes.

a. **M57 HE Cartridge (NDI)** (Figure 7-9).

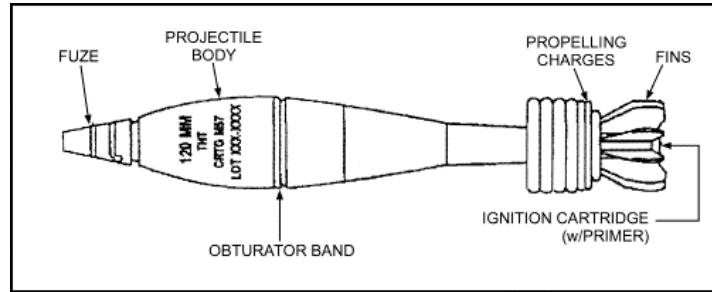

Figure 7-9. M57 HE cartridge.

- (1) Type and use: High explosive fragmentation and blast.
- (2) Identification: Olive drab with yellow markings.
- (3) Components: M935 point detonating (PD) fuze.
- (4) Maximum range: 6,300 meters at charge 8; 7,200 meters at charge 10.
- (5) Remarks: Used against personnel (in open or in bunkers), light vehicles, and light bunkers; weight to 20 pounds (13.18 kilograms).

b. **M68 Smoke Cartridge (NDI)** (Figure 7-10).

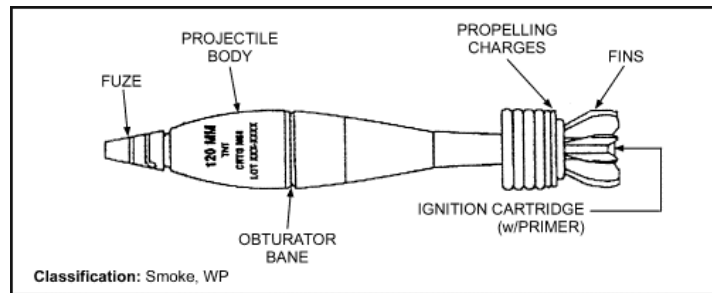

Figure 7-10. M68 smoke cartridge.

- (1) Identification: Light green with red markings.
- (2) Components: M935 PD fuze.
- (3) Maximum range: 6,300 meters at charge 8; 7,200 meters at charge 10.
- (4) Remarks: Used for screening and spotting.

WARNING

At temperatures exceeding 111.4 degrees Fahrenheit (44.1 degrees centigrade) (melting point of WP), store and transport WP rounds in a vertical position (nose up) to prevent voids in the WP.

c. M91 Illumination Cartridge (NDI) (Figure 7-11).

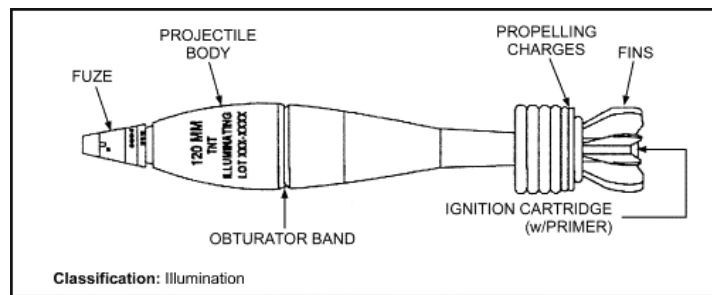

Figure 7-11. M91 illumination cartridge.

- (1) Identification: White with black markings.
- (2) Components: M776 (DM93) mechanical time superquick (MTSQ) fuze.
- (3) Maximum range: 6,200 meters at charge 8; 7,100 meters at charge 10.
- (4) Remarks: Contains candle and parachute used for illumination (weight to 29 pounds [13.18 kilograms]); burn time--46 to 60 seconds; candle power--1,000,000.

d. M933 HE Cartridge (Figure 7-12).

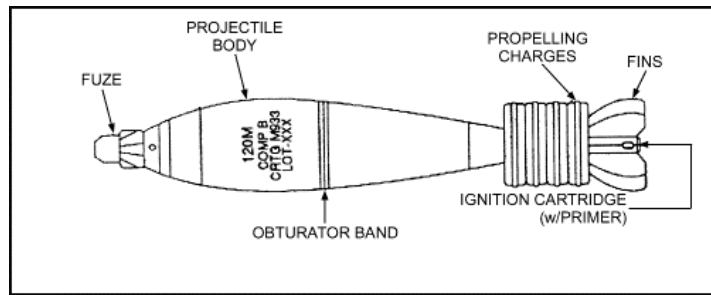

Figure 7-12. M933 HE cartridge.

- (1) Type and use: High explosive fragmentation and blast.
- (2) Identification: Olive drab with yellow markings.
- (3) Components: M745 PD fuze; M230 propelling charge.
- (4) Maximum range: 7,200 meters at charge 4.
- (5) Minimum range: 200 meters at charge 0.

e. M934 HE Cartridge (Figure 7-13).

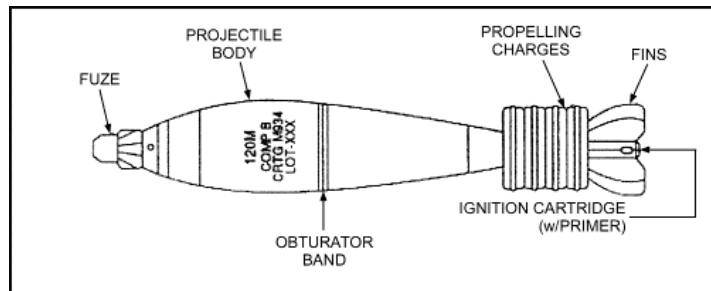

Figure 7-13. M934 HE cartridge.

- (1) Type and use: High explosive fragmentation and blast.
- (2) Identification: Olive drab with yellow markings.
- (3) Components: M745 PD fuze; M230 propelling charge.

(4) Maximum range: 7,200 meters at charge 4.

(5) Minimum range: 200 meters at charge 0.

f. **M929 Smoke Cartridge** (Figure 7-14).

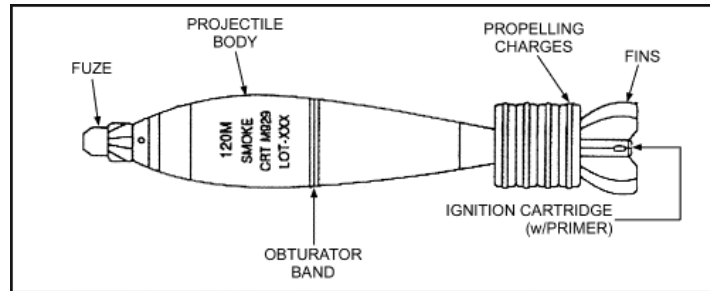

Figure 7-14. M929 smoke cartridge.

(1) Type and use: Smoke (white phosphorus); screening and spotting.

(2) Identification: Light green with light red markings.

(3) Components: M745 PD fuze, M230 propelling charge.

(4) Maximum range: 7,200 meters at charge 4.

(5) Minimum range: 200 meters at charge 0.

WARNING

At temperatures exceeding 111.4 degrees Fahrenheit (44.1 degrees centigrade) (melting point of WP), store and transport WP rounds in a vertical position (nose up) to prevent voids in the WP.

7-29. PREPARATION FOR FIRING

Follow the procedures described herein to prepare for firing.

a. Unpack cartridge.

(1) Remove the protective bag and desiccant bags (if any) secured to or covering the fin assembly.

Note: Examine the fin assembly for visible damage or looseness. Examine the fuzes and propelling charges for visible damage. Tighten loose fin assemblies (by hand) before firing. Cartridges with damaged (bent) fin assemblies, fuzes, or propelling charges will be turned in to the ammunition supply point as unserviceable.

(2) Remove the plastic shell or insert assembly (if any) covering the propelling charge.

b. Set the fuze for the required time or desired type of burst.

c. Adjust the propelling charge for desired range.

d. Remove or pull the safety wires (just before loading and firing the cartridge).

7-30. LOADING AND FIRING

Follow the procedures described herein to load and fire the 120-mm mortar.

a. Check to ensure that the cartridge has the proper amount of charge.

b. Remove the safety wire or clip (if any) before firing.

WARNINGS

1. Always check the mask and overhead clearance before firing.

2. PD and proximity fuzes may prematurely function when fired through extremely heavy rainfall.

3. Do not fire ammunition in temperatures above +146 degrees Fahrenheit (+63 degrees centigrade) or below -28 degrees Fahrenheit (-33 degrees centigrade).

4. Short rounds and misfires can occur if an excessive amount of oil or water is in the barrel during firing.

5. Before loading the cartridge, ensure the barrel and cartridge are free of sand, mud, moisture, snow, wax, or other foreign matter.

6. Ensure that all packing materials (packing stops, supports, and plastic bags) are removed from the cartridge.

7. Any glue or other foreign substance adhering to the cartridge, particularly at or near the obturator band, must be removed. If the substance cannot be removed, the cartridge will not be fired.

7-31. UNFIRED CARTRIDGES

This paragraph describes the procedures to follow for unfired cartridges.

- a. Replace the safety wire or clip, if removed from the fuze.

Note: If safety pins cannot be fully reinserted into the fuze, notify EOD.

- b. Reset the fuze (see paragraph 7-35).

- c. Reinstall the propellant increments so that the cartridge has a full charge in proper order.

Notes: 1. M57, M68, and M91 cartridges should have seven propellant increments. The proper order is one brown, two blue, and four white.

2. Do not mix propelling charge models or lots. Use original increments.

- d. Install packing stop. Repack cartridge.

7-32. CARE AND HANDLING OF CARTRIDGES

This paragraph describes the procedures to follow to care for and handle cartridges.

- a. Do not throw or drop live ammunition.

- b. Do not break the moisture resistant seal of the ammunition container until the cartridges are to be fired.

- c. Protect cartridges when removed from the ammunition container. Protect ammunition from rain and snow. Do not remove the plastic shell or insert assembly around the propelling charge until the propelling charge is to be adjusted. If protective bags were packed with the cartridge, cover the fin assembly and propelling charge to prevent moisture contamination. Stack cartridges on top of empty ammunition boxes or on 4 to 6 inches (10 to 15 centimeters) of dunnage. Cover cartridges with the plastic sheets provided.

- d. Do not expose cartridges to direct sunlight, extreme temperatures, flame, or other sources of heat.
- e. Cartridges must be shielded from small-arms fire.
- f. Store WP-loaded cartridges at temperatures below 111.4 degrees Fahrenheit (44.1 degrees centigrade) to prevent melting of the WP filler. If this is not possible, WP-loaded cartridges must be stored fuze-end up so that WP will resolidify with the void space in the nose end of the cartridge (after temperature returns below 111.4 degrees Fahrenheit [44.1 degrees centigrade]). Failure to observe this precaution could result in rounds with erratic flight.
- g. Store WP-loaded ammunition separate from other types of ammunition.
- h. Notify EOD of leaking WP cartridges. Avoid contact with any cartridges that leak.
- i. Protect the primer of cartridges during handling.
- j. Do not handle duds other than when performing misfire procedures.

7-33. FUZES

The fuzes used with cartridges for the 120-mm mortar are described in the following paragraphs.

- a. **M776 MTSQ Fuze** (Figure 7-15).

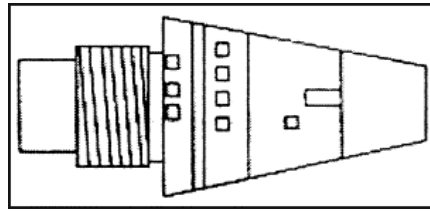

Figure 7-15. M776 MTSQ fuze.

- (1) Functions: Air burst or impact.
- (2) Settings: Six to 52 seconds.
- (3) Remarks: The fuze has a mechanical arming and timing device, expulsion charge, and safety wire or pin.

b. **M935 PD Fuze** (Figure 7-16).

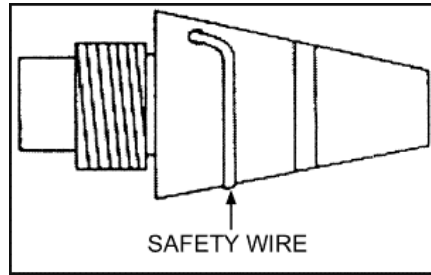

Figure 7-16. M935 PD fuze.

- (1) Functions: Impact.
- (2) Settings: Superquick or 0.05-second delay action.
- (3) Remarks: The fuze has a safety wire.

c. **M734 Multioption Fuze** (Figure 7-17).

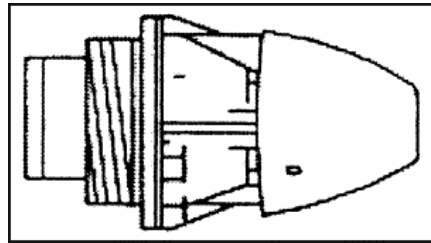

Figure 7-17. M734 multioption fuze.

- (1) Functions: Proximity or impact.
- (2) Settings: PRX, NSB, IMP, or DLY.
- (3) Remarks: The fuze can be set by hand.

d. **M745 PD Fuze** (Figure 7-18).

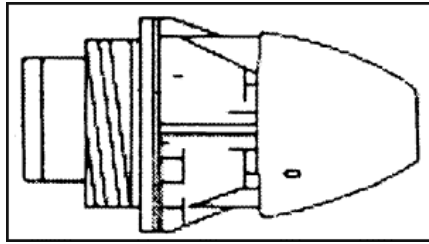

Figure 7-18. M745 PD fuze.

- (1) Functions: Impact.
- (2) Settings: None.
- (3) Remarks: The fuze functions on impact with superquick action only. The markings (PRX, NSB, IIMP, and DLY) are dummy settings. Rotation of the fuze head does not alter the function mode.

7-34. SETTING FUZES

The following paragraphs describe how to set fuzes for different functions.

a. M935 PD Fuze (Figure 7-19).

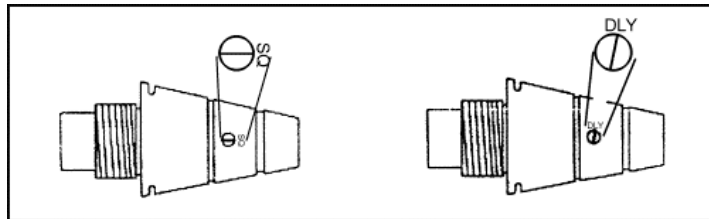

Figure 7-19. Setting the M935 PD fuze.

- (1) Superquick setting.
 - (a) These fuzes are shipped preset to function superquick on impact.
 - (b) Verify the setting before firing. The selector slot should be aligned with the SQ mark.
- (2) Delay setting.

(a) Turn the selector slot in a clockwise direction until the slot is aligned with the DLY mark.

(b) Use a coin or a flat-tip screwdriver to change settings.

b. **M776 (DM93) MTSQ Fuze** (Figure 7-20).

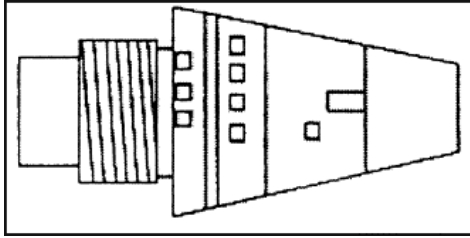

Figure 7-20. Setting the M776 (DM93) MTSQ fuze.

(1) Rotate the head of the fuze to the left (counterclockwise) until the inverted triangle or index line is aligned with the correct line and number of seconds of the time scale.

(2) Use the fuze setter to rotate the head of the fuze.

Note: Once the desired setting has been passed, continue counterclockwise to reach the desired setting. Try to index the desired setting in as few rotations as possible.

(3) See the firing table for the correct time setting.

(4) Remove the fuze safety pin or wire before firing.

c. **M745 PD Fuze.** No setting is required. The fuze functions on impact with superquick action only. Disregard the markings (PRX, NSB, IMP, and DLY) on the fuze head.

d. **M734 Multioption Fuze** (Figure 7-21). Fuze can be set by hand by rotating the fuze head (clockwise) until the correct marking (PRX, NSB, IMP, or DLY) is over the index line.

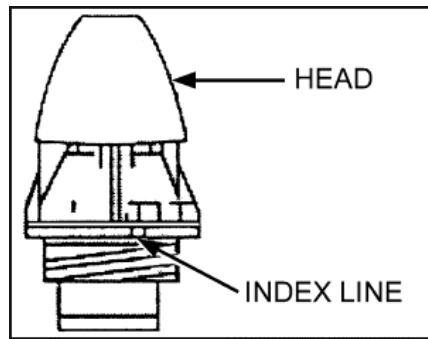

Figure 7-21. Setting the M734 multioption fuze.

- PRX--Proximity. The fuze comes set to PRX. Burst height is 3 to 13 feet (1 to 4 centimeters).
- NSB--Near surface burst (nonjamming). Burst height is 0 to 3 feet (0 to 1 meter).
- IMP--Impact (superquick).
- DLY--Delay (0.050 seconds).

7-35. RESETTING FUZES

This paragraph describes how to reset fuzes.

- a. **M935 PD Fuze.** Align the selector slot with the SQ mark.
- b. **M776 MTSQ Fuze.** Rotate the head of the fuze (counterclockwise) until the safe line (S or inverted triangle of the time scale) is aligned with the index line of the fuze body. Replace the safety wire.
- c. **M754 Multioption Fuze.** Rotate the fuze head (counterclockwise) until the PRX marking is over the index line.
- d. **M745 PD Fuze.** No resetting is required.

CHAPTER 8

FIRE WITHOUT A FIRE DIRECTION CENTER

The use of the target-grid method of fire control may not always be possible or desirable for placing fire on a target. Communications failure, casualties from enemy fire, lack of equipment, or the tactical situation may require that one or more mortars be employed without an FDC.

Section I. FIRE PROCEDURES

When the squads are under squad control, the FO or squad leader observes the target area, and adjusts and controls the fire by commands that are sent directly to the mortar crew. Employment of mortars without an FDC is only temporary--the FDC should be established as soon as possible.

8-1. ADVANTAGES AND DISADVANTAGES

Some of the advantages and disadvantages of operating without an FDC are discussed herein.

a. Advantages of operating without an FDC include:

- Speed in engaging a target.
- Better response to commanders.
- Fewer requirements for personnel and equipment.

b. Disadvantages of operating without an FDC include:

- The limited movement capability of the FO.
- The difficulty of massing or shifting fires on all targets within the range of the mortar.
- The necessity of locating the mortar position too far forward, where it is subject to enemy fire delivered on the friendly frontlines.
- Greater ammunition resupply problems.

8-2. FIRING DATA

The direct-alignment or direct-lay methods can be used to lay the mortar for direction. Initial range can be determined by--

- Eye estimation.
- Map, photographic map, or aerial photograph.
- Mil-relation formula.

8-3. OBSERVER CORRECTIONS

In fire without an FDC, the FO makes corrections differently than when operating with an FDC. He makes all his deviation corrections with respect to the gun-target (GT) line rather than with respect to the observer-target (OT) line. All deviation corrections are sent in mils or turns of the traversing handwheel.

a. Forward Observer Within 100 Meters of Mortar Position. The best FO location for rapid fire adjustment on the mortar is at the mortar position.

(1) The tactical employment of the mortar usually requires the FO to be in a position other than at the mortar. However, if the FO is located within 100 meters of the mortar position, the deviation error he reads in his binoculars can be applied directly to the sight without computation. This is true because the angle between the observer-burst line and OT line is equal to the angle between the mortar-burst line and GT line. Any slight difference between these two angles is compensated for by the inherent dispersion of the weapon and the bursting area of the round.

(2) For example, if the FO from a position within 100 meters of the mortar location observes the burst to the left of the target and reads that it is 40 mils left on the mil scale of his binoculars, he orders a correction of RIGHT FOUR ZERO. This correction is sent to the mortar in mils and is not converted to meters. The gunner applies this correction directly to the previous deflection setting using the LARS (left add, right subtract) rule.

b. Forward Observer More Than 100 Meters From Mortar Position. The FO cannot always be located within 100 meters of the mortar position.

(1) When the FO cannot locate within 100 meters of the mortar position, he must be within 100 meters of the gun-target line (Figure 8-1). This might prevent him from visualizing the gun-target line and getting within 100 meters of it. If the FO is attacking targets over a wide frontage, he would be required to move often but with limited movement. Therefore, the angle that exists between the mortar-burst line and GT line is not equal to the angle that exists between the observer-burst line and OT line--computations must be made to correct these differences.

(2) For example, if the FO is halfway between the mortar and target, the correction to be made on the sight is one-half his deviation spotting; if the mortar is half-way between the FO and the target, the correction is twice his deviation spotting. As other distances give other ratios, a correction factor must be applied to the number of mils spotted before ordering a deflection change. This factor is a fraction, the numerator of which is the OT distance and the denominator of which is the GT distance.

EXAMPLE:

If the distance from the FO to the target is 1,000 meters, the GT distance is 1,200 meters, and the deviation of the burst from the target, as read by the FO, is 60 mils (Figure 8-1), the correction is--

$$\frac{1,000}{1,200 \text{ (or } 5/6)} \times 60 \text{ mils} = 50 \text{ mils}$$

In applying this factor, simplicity and speed are important. The distances used should be to the nearest 100 meters.

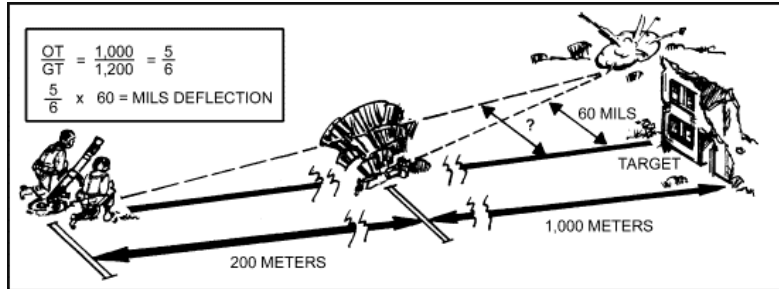

Figure 8-1. Observer more than 100 meters from mortar but within 100 meters of GT line.

8-4. INITIAL FIRE COMMANDS

Initial fire commands contain the necessary data to lay the mortars and fire the first round. The sequence for transmission of the initial fire command is as follows:

- Mortars to follow.
- Type of projectile and fuze.
- Mortars to fire.
- Method of fire.
- Deflection.
- Charge.
- Time setting.
- Elevation.

8-5. FIRE COMMANDS

Fire commands originate with the squad leader at the observation post when mortars are employed without an FDC.

a. **Normal Fire Commands.** The commands used in observed fire procedures without an FDC follow the procedure outlined above with the following exceptions:

(1) *Direction.* When operating without an FDC, the FO gives the direction as a shift from a known point (normally the registration point) in the initial fire command. In subsequent commands, he gives the deflection correction from the last round fired. For example, during an adjustment the FO requests moving the next burst right 50 mils. Regardless of the sight setting, his command for deflection is RIGHT FIVE ZERO. The gunner applies the LARS rule to obtain the deflection to be placed on the sight. The sight has a deflection setting of 20 mils; therefore, the gunner subtracts 50 mils from 20 mils and obtains the new sight setting of 3150 mils. Normally, when the registration has been completed, the aiming posts are placed out on a referred deflection.

(2) *Elevation (range).* The FO may refer to a firing table, determine the charge and elevation (in mils) corresponding to the GT range, and announce this charge and elevation in his fire command. He may, however, announce the range in meters and have the gunner refer to a firing table to determine the charge and elevation.

b. **Modified Fire Commands.** Modified fire commands differ from normal fire commands only in that the deflection and elevation changes in subsequent commands are given as turns of the traversing handwheel and elevating crank.

(1) The advantages of modified fire commands are speed and simplicity of execution by the gunner. One turn of the traversing handwheel is equal to about 10 mils of deflection, and unabridged firing tables have a column for the number of turns of the elevation crank to change the range 100 meters. When using modified fire commands, deflection and elevation changes are computed to the nearest quarter turn. When the FO anticipates using modified fire commands involving turns of the elevating crank, he is required to announce the range element of the initial fire command as a charge and elevation. This ensures that the FO and gunner are working in the same charge zone, since the number of turns required to move the burst of a round a given distance on the ground can vary considerably between two charge zones.

(2) The gunner lays the mortar for direction and elevation as given in the initial fire command; he does not need to refer to a firing table. Following the initial fire command, the gunner makes no attempt to align the sight on the aiming point or to level the elevation bubble. He makes the corrections by taking the turns given in the subsequent commands and keeping the cross-level bubble centered. If the gunner can no longer traverse in the desired direction, he should be able to align the sight on the aiming point,

to center the traversing bearing, to relay on the aiming point, and to resume traverse.

(3) In computing the number of turns of the elevation crank between two elevations in mils (taken from the firing table), the FO subtracts the smaller elevation from the larger and divides by 10 (one turn of the elevating crank being equal to about 10 mils of elevation). In the ladder method and bracketing method of adjustment for range, once the FO has obtained a bracket on the target, he does not need the firing table. He continues the adjustment by halving the number of turns of the elevating crank that established the preceding bracket.

EXAMPLE:

MODIFIED FIRE COMMANDS	NORMAL FIRE COMMANDS
RIGHT FOUR TURNS	RIGHT FOUR ZERO
DOWN NINE TURNS	ONE SEVEN ZERO
LEFT TWO TURNS	ZERO
UP FOUR AND ONE- HALF TURNS	LEFT TWO ZERO
RIGHT ONE TURN	ONE SIX ZERO ZERO
DOWN TWO TURNS	RIGHT ONE ZERO
THREE ROUNDS	ONE SIX FIVE ZERO
UP ONE TURN	THREE ROUNDS
	ONE SIX TWO FIVE

In this example, the first round burst between the FO and target. In a different example, assume that the first round was fired at a range of 900 meters and burst beyond the target. The FO wants to DROP ONE ZERO ZERO (100) for the next round and gives a modified fire command in turns of the elevating crank. Using charge 1, the elevation for the first round at 900 meters is 1275 mils. The elevation for a range of 800 meters is 1316 mils. Subtracting 1275 mils from 1316 mils gives a difference in elevation for the two ranges of 41 mils, or 4 turns. Therefore, the subsequent command to fire the second round is UP FOUR TURNS. The second round now bursts short of the target, establishing a bracket. The FO desires to split the bracket and commands, DOWN TWO TURNS, or one-half the number of turns that he previously gave to bracket the target. With this command, the FO is splitting a 100-meter bracket and could specify an FFE if he was engaging a tactical area target.

8-6. FIRE CONTROL

The FO controls the fire from an observation post, issuing fire commands directly to the mortar crew. He may select an OP close enough to the mortar so that he can give his fire commands orally to the mortar crew. When the OP is not close to the mortar position, the FO uses a telephone or radio to transmit fire commands.

8-7. MOVEMENT TO ALTERNATE AND SUPPLEMENTARY POSITIONS

When time or the situation dictates, the mortar may be moved to both alternate and supplementary positions, and registered on the registration point, final protective fire (in the defense), and as many targets as possible.

8-8. SQUAD CONDUCT OF FIRE

Conduct of fire includes all operations in placing effective fire on a target--for example, the FO's ability to open fire when he desires, to adjust fire, to determine the distribution of fire upon the target, to shift fire from one target to another, and to regulate the kind and amount of ammunition expended. Quick actions and teamwork of squad members are required.

- a. The normal sequence of instruction is on the 1,000-inch range, followed by the training shell range, and, finally, in the field with practice or combat ammunition.
- b. To ensure maximum efficiency, each squad member is acquainted with the principles of technique of fire for each type of adjustment and FFE. Frequent rotation of duty helps squad members to better understand this technique of fire. The FO is trained in all methods and techniques used in bringing effective fire on a target as quickly as possible.

8-9. REFERENCE LINE

The normal method of establishing initial direction when operating without an FDC is the direct-alignment method. After the initial direction has been established, the FO should conduct a registration on his registration point using only the direction stake as a reference point. After registration is completed, a reference line should be established by placing out aiming posts on a referred deflection, which then becomes the registration point or base deflection.

8-10. FIRE ADJUSTMENT

The FO normally adjusts fire by the bracketing or creeping method. He makes his spottings and gives his corrections with respect to the OT line. An off-line burst is brought to the OT line by applying a correction, which is determined by multiplying the observed deviation in mils by the estimated OT distance in thousands of meters (the deflection conversion table may also be used to determine this correction). The deviation

correction is sent to the FDC as RIGHT or LEFT. Bursts are kept graphically on the OT line by the FDC. The FO sends range corrections in meters to the FDC. When using the bracketing method of adjustment, the FO determines range corrections along the OT line by seeking an initial range bracket and thereafter successively splitting the bracket until the correct range is determined. When using the creeping method, the FO proceeds as discussed in Section IV.

8-11. SQUAD USE OF ILLUMINATION AND SMOKE

Illumination is designed to assist friendly forces with light for night operations. Smoke is used to obscure the enemy's vision for short periods.

a. **Use of Smoke.** After careful evaluation of the terrain and weather, the FO locates a point on the ground where he wishes to place a flank on his screen. For example, if a flanking wind prevails, the FO normally locates the point of impact in front of the target and upwind. If necessary, the FO adjusts fire to determine the correct location of this point. For a screening mission, splitting a 100-meter bracket is normally sufficient.

b. **Use of Illumination.** Control over the use of infantry mortar illuminating rounds is exercised by the battalion commander after coordination with adjacent units through the next higher headquarters. The correct relative position of the flare to the target depends upon the wind and terrain. The point of burst is so placed as to give the most effective illumination on the target and to make sure that the final travel of the flare is not between the FO and target. It is not necessary to adjust the round directly over the target due to the wide area of illumination.

(1) If there is a strong wind, the point of burst must be placed some distance upwind from the target so the flare drifts to the target location. The flare should be slightly to one flank of the target and at about the same range. When the target is on the forward slope, the flare is placed on the flank and at a slightly shorter range.

(2) For adjustment on a prominent target, better visibility is obtained by placing the flare beyond the target to silhouette it and to prevent adjustment on the target's shadow. When firing continuous illumination, a strong wind can decrease the time interval between rounds. For maximum illumination, the flare is adjusted to burn out shortly before reaching the ground.

8-12. ATTACK OF WIDE TARGETS

To attack wide targets, the FO must use distributed FFE. In distributed FFE, the gunner fires a specified number of rounds but manipulates the mortar for range or deflection between each round. Distributed fire on wide targets is called *traversing fire*. To place

traversing fire on a target, the FO must adjust fire on one end of the target, normally the end nearest to a known point.

a. After adjustment, the FO determines the width of the target in mils by using the mil scale in the binoculars, or by reading an azimuth to each end and subtracting the smaller from the larger. He then divides the mil width by 10, which is the number of mils that one turn of the traversing handwheel moves the mortar. This determines the number of turns needed to traverse across the target (computed to the nearest one-half turn).

b. In computing the number of rounds, the FO divides the width of the target by the bursting area of the round. He then divides the total number of turns by the number of intervals between the rounds to be fired to determine the number of turns between rounds (computed to the nearest one-half turn). There will always be one less interval than the number of rounds fired in the FFE phase.

c. After adjustment and before issuing the subsequent fire command, the FO must tell the gunner to prepare to traverse right or left. The gunner traverses the mortar all the way in the direction commanded and then back two turns (four turns on M120) on the traversing handwheel. With the aid of the assistant gunner, the gunner moves the bipod legs until he is approximately re-laid on his aiming posts. Using the traversing mechanism, the gunner then completes realigning the mortar and announces, "Up."

d. When the mortar is laid, the FO issues his subsequent fire command, announcing the number of rounds to be fired and the amount of manipulation between each round.

e. In Figure 8-2, the FO measures the width of his target to be 75 mils. Using a map, he estimates the range to be 2,200 meters. Using the mil relation formula, he determines the width of the target to be 165 meters and decides to attack the target with seven rounds. There will be six intervals between the seven rounds. Since the target is 75 mils wide, he determines the number of turns to be $7 \frac{1}{2}$ turns. To determine the number of turns between rounds, he divides the number of turns by the number of intervals ($7 \frac{1}{2}$ divided by 6 = 1.07). This is rounded off to the nearest one-half turn (1 turn).

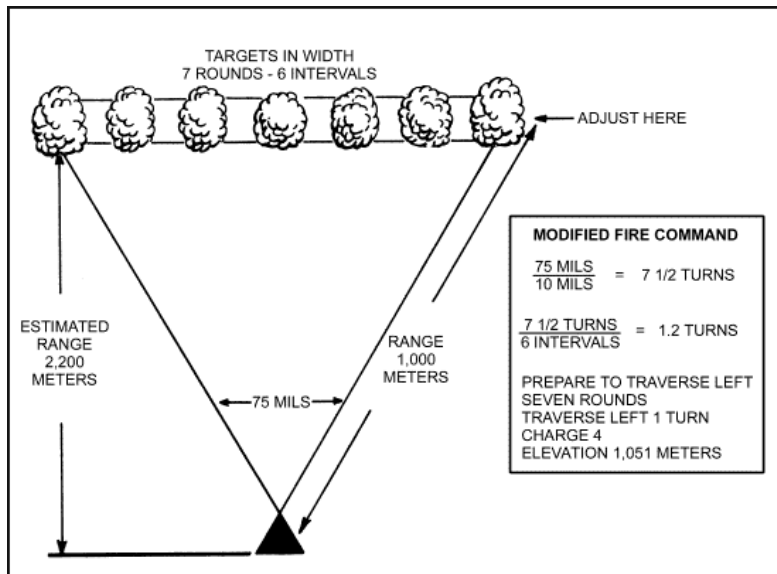

Figure 8-2. Traversing fire.

Note: When determining the rounds for FFE, the FO applies the following rule: one round for each 30 meters and four rounds for each 100 meters.

8-13. ATTACK OF DEEP TARGETS

The FO uses searching fire to place effective fire on deep targets (Figure 8-3). To engage a deep target, the FO must adjust on one end of the target, normally the far end. When the FO anticipates using searching fire, he announces the range as a charge and elevation. (See FM 23-91 for information on zone fires.)

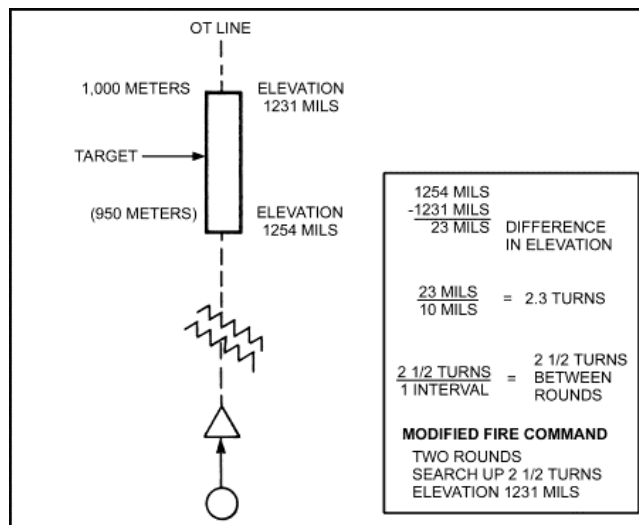

Figure 8-3. Searching fire.

- a. After adjustment is completed on one end of the target, the FO estimates the range to the other end of the target. Use of the firing table determines the number of turns of the elevating crank needed to change the range 100 meters. If the FO does not have this information, he can decide the number of turns by determining the difference in elevation in mils that exists between the two ranges. He divides this difference by 10 to determine the number of turns needed on the elevating crank to cover the target.
- b. The FO must then determine the number of rounds to be fired. Usually five rounds covers an area 100 meters deep, except at long ranges where dispersion is greater. Once he has determined the number of rounds to be fired, he determines the number of intervals between rounds. There will *always* be one less interval than the number of rounds fired.
- c. The FO then divides the total number of turns required by the total number of intervals to determine the number of turns the gunner must make between each round (compute to the nearest one-half turn).

EXAMPLE:

If the FO has adjusted to the far end of the target and found it to be 1,000 meters, he estimates the near edge of the target to be 950 meters. By using the firing table, he determines that he must make

five turns of the elevating crank to change the range 100 meters. Since the FO only wants to make a 50-meter change, he makes only half of the turns, which is 2 1/2 turns. If he did not have this information, he would determine that there is a 23-mil difference in elevation for the two ranges (elevation 1231 mils for range 1,000 meters, and elevation 1254 mils for range 950) and, by dividing by 10, that it would require two turns of the elevating crank.

The FO has determined that he will use three rounds to attack the target. There will be one interval between the two rounds fired. Then the FO divides the total number of turns required by the number of intervals, and rounds off the answer to the nearest one-half turn.

$$2 \frac{1}{2} \div 1 \text{ (interval)} = 2 \frac{1}{2} \text{ turns between rounds}$$

The FO is now ready to send the subsequent fire command to the gunner. The commands are:

TWO ROUNDS
SEARCH UP TWO AND ONE-HALF TURNS
ELEVATION ONE TWO THREE ONE (1231)

The gunner is told to search in the direction that the barrel moves. For this example, the barrel moves from 1231 mils to 1254 mils of elevation; therefore, the command is SEARCH UP.

Section II. DIRECT-LAY METHOD

In the direct-lay method of emplacing a mortar, the gunner sees the target through the mortar sight. No directional or aiming posts, FO, or FDC is used. The firing table should be used to try to obtain a first-round hit. If the first-round hit is not achieved, the firing table should be used to obtain a bracket. Depending on the location of friendly troops to the target, the bracket method, modified ladder method, or creeping method of adjustment apply.

8-14. STEP 1: INITIAL FIRING DATA

The elevation setting and charge selected should be obtained from a firing table. In the absence of a firing table, they can be determined through unit SOP or by other expedient techniques such as memorizing charge and elevation for 1,000, 2,000, and 3,000 meters; and firing with the charge and elevation setting closest to the estimated target range.

- a. Determine initial range by--

- Estimating.
- Using maps, photographic maps, and so on.
- Intersecting.

Note: When using the 4.2-inch mortar, the gunner must add drift to the sight after laying on the center of the target.

b. Place a 3200-mil deflection on the sight, and lay on the center of the target. With the appropriate elevation setting on the sight, center all bubbles by adjusting the lay of the barrel. Take appropriate actions to preclude damage to the sight and, with established charges, fire the first round. Replace the sight, if needed, and observe the burst of the round.

8-15. STEP 2: REFERRING THE SIGHT

Referring the sight centers the vertical line of the sight reticle on the burst.

- a. If the burst is over the target, turn the elevating crank up 4, 8, or 16 turns (8, the median, gives a significant change without becoming extreme), depending on the gunner's sensing of the round, range to the target, and other possible factors. If the burst is short, turn the elevating crank down 4, 8, or 16 turns.
- b. Turn the sight elevation micrometer knob to center the elevation bubble. (If the deflection change requires a bipod displacement, the desired range change is maintained.)
- c. Re-lay the barrel on center of target (centering both bubbles by adjusting the barrel. Fire the second round and observe the burst.

Note: Any alternate method of correction for range is to use the firing table.

8-16. STEP 3: BRACKETING THE TARGET

If the second round is a line shot and brackets the target, the bracket is split by changing the elevation of the barrel half the number of turns used in STEP 2. (If in STEP 2 the barrel was cranked up eight turns, now crank down four.) The third round is fired.

- a. If the second round is not a line shot but does bracket the target, refer the sight to center of burst and split the bracket by changing the elevation of the barrel half the number of turns used in STEP 2. Change the sight to the center elevation bubble, and then re-lay the barrel on center of target (centering both bubbles by changing the lay of the barrel).
- b. If the second round is not a line shot and does not bracket the target, repeat STEP 2 until a bracket is obtained.

8-17. STEP 4: FIRE FOR EFFECT

The appropriate actions of STEP 3 are repeated until an effect on the target is seen, then mortars fire for effect.

- a. After obtaining hits, change the sight to center the elevation bubble and vertical line of the sight reticle on the target, then record these data. Number the target and retain the number along with appropriate firing data. The mortar can be taken out of action, moved a short distance, and placed back into action with the mortar able to quickly and accurately attack the recorded target or other close targets.
- b. If fired upon during any of the above steps, the mortar can be displaced 75 to 100 meters with minimal effect on the fires as long as the elevation setting for the last round fired has been recorded or memorized. Once in the new position, use the recorded/memorized data as a starting point and then complete the interrupted step.

Section III. DIRECT-ALIGNMENT METHOD

When the FO/squad leader prepares the initial firing data, he uses the quickest and simplest method available. Initial data consist of a direction of fire and mortar-target range.

8-18. MORTAR DISMOUNTED

If the mortar is dismounted, the squad leader moves to a vantage point where he can see the targets and places out an aiming post. He directs a member of the mortar squad to place out a second aiming post (to be used as a baseplate assembly stake), aligning it with the first aiming post and target. The mortar crew mounts the mortar at the baseplate assembly stake, places 3200 mils deflection on the sight, and traverses the mortar, aligning the sight on the aiming post placed out by the squad leader. The gunner uses this aiming post as an aiming point or he may place out other aiming posts to be used as aiming points.

8-19. MORTAR MOUNTED

If the mortar is mounted, the squad leader moves to a vantage point on a line between the mortar and target. He places out an aiming post (direction stake) on which the gunner lays the mortar with the deflection set at 3200. The gunner uses this aiming post as an aiming point or he may place out other aiming posts to be used as aiming points.

Note: The squad leader can also move to a vantage point behind the gun.

8-20. NATURAL OBJECT METHOD

When the tactical situation does not permit alignment of aiming posts and the mortar is rapidly placed into action, the squad leader can establish the mounting azimuth as follows: He selects an object with a clearly defined vertical edge that is situated in the general direction of fire. He directs the gunner to mount and lay the mortar on the edge of this object with the deflection scale set at 3200 mils. By using the aiming point as a reference point, he can place fire on a target to the right and left by determining the angle in mils between the aiming point and target. He directs the gunner to place the corresponding deflection on the mortar using the LARS rule.

Section IV. ADJUSTMENT OF RANGE

The normal procedure for the adjustment of range is the establishment of a bracket along the OT line. A bracket is established when one group of rounds falls over and one group of rounds falls short of the adjusting point. The FO must establish the bracket early in the adjustment and then successively decrease the size of the bracket until it is appropriate to enter FFE.

8-21. RANGE SPOTTINGS

Definite range spottings are required to make a proper range adjustment. Any range spotting other than DOUBTFUL or LOST (UNOBSERVED) is definite.

a. Definite range spottings include:

- A burst or group of bursts on the OT line.
- A burst(s) not on the OT line by using a knowledge of the terrain, drifting smoke, shadows, and wind; caution and good judgment are required.
- The location of the burst fragmentation pattern on the ground.

b. Possible range spottings include:

- (1) *Over*. A burst that appears beyond the adjusting point.
- (2) *Short*. A burst that appears between the FO and adjusting point.
- (3) *Target*. A round that bursts within the target area.
- (4) *Range correct*. A burst or center of a group of bursts that is at the proper range.
- (5) *Doubtful*. A burst that can be observed but cannot be determined as over, short, target, or range correct.
- (6) *Lost over (short)*. A burst that is not observed but known to be definitely beyond or short of the adjusting point.

8-22. MISCELLANEOUS SPOTTINGS

Miscellaneous spottings are described herein.

- a. **Lost.** A burst is lost when its location cannot be determined. Lost rounds must be reported to the FDC, and a bold shift in deviation or range should be made.
- b. **Erratic.** A round that varies greatly from normal behavior is classified as an erratic round.

8-23. BRACKETING METHOD

When the first definite range spotting is obtained, the FO should make a range correction that is expected to result in a range spotting in the opposite direction--for example, if the first definite range spotting is SHORT, the FO should add enough to get an OVER with the next round. The inexperienced FO should use the following guide to determine the initial range change to establish a bracket (Figure 8-4).

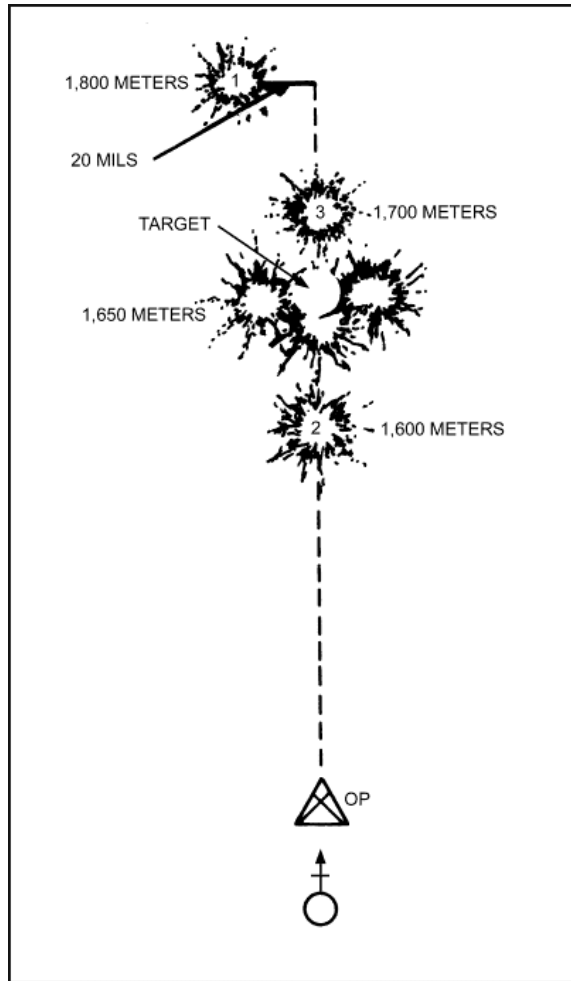

Figure 8-4. Bracketing method.

OT DISTANCE	MINIMUM RANGE CHANGE (ADD OR DROP)
Up to 999 meters	100 meters

Over 1,000 to 1,999 meters	200 meters
2,000 meters and over	400 meters

a. Once a bracket has been established, it is successively decreased by splitting it in half until it is appropriate to enter FFE. FFE is usually requested in area fire when a 100-meter bracket is split.

b. The FO must use his knowledge of the terrain, knowledge gained from previous firing, general experience, and good judgment in determining the size of the initial and subsequent range changes. For example, if the FO adds 800 after an initial range spotting of SHORT and the second range spotting is OVER but the bursts are much closer to the adjusting point than the initial rounds, a range change of DROP 200 would be appropriate.

8-24. CREEPING METHOD OF ADJUSTMENT

When danger-close mission is requested, the creeping method of adjustment is used. When the FO requests an adjustment on a target that is within 400 meters of friendly troops, he adds a 200-meter safety factor to ensure that the first round does not fall short. When the initial round is spotted, he estimates the overage in meters. He then makes the correction for range by dropping half of the estimated overage. Once he has given a correction of DROP FIVE ZERO (50), he continues a DROP FIVE ZERO (50) until he has either a RANGE CORRECT or TARGET or SHORT spotting. If, during the adjustment, a round falls short of the target, the FO continues the adjustment using the bracket method of adjustment.

8-25. NORMAL FIRE COMMANDS

The commands used in conduct of fire without an FDC follow the procedures discussed in paragraphs 8-4 and 8-5 with the following exceptions:

a. **Deflection (Direction).** When operating without an FDC, the FO normally gives the deflection as a shift from a known point in the initial fire command. In subsequent commands, he gives the deflection correction from the last round fired. For example, during an adjustment an FO desires to move the next burst 50 mils right. Regardless of the sight setting, his command for deflection is RIGHT FIVE ZERO. The gunner arrives at the deflection to be placed on the sight by applying the LARS rule.

b. **Elevation (Range).** The FO may refer to a firing table to determine the charge and elevation corresponding to the gun-target range. He announces this charge and elevation in his fire command. He may, however, announce the range in meters and have the gunner refer to the firing table to determine the charge and elevation. The gunner applies the deflection correction to the previous deflection

setting, determines the charge and elevation for the given range on the firing table, announces the charge to the first ammunition bearer, sets the elevation on the sight, and then lays for elevation and deflection. After selecting a constant elevation, the FO announces the charge for only range changes.

8-26. MODIFIED FIRE COMMANDS

The deflection and range changes in subsequent commands differ from usual fire commands in that they are given as turns of the traversing crank and changes in charge. The advantages of modified fire commands are speed and simplicity of execution by the gunner.

- a. One turn of the traversing crank is equal to about 10 mils of deflection, while three-eighths of a charge is equal to about 50 meters change in range. When using modified fire commands involving changes in range, the FO announces the range element of the initial fire command as charge and elevation. This ensures that the squad leader and gunner are working with the same constant elevation.
- b. The gunner lays the mortar for direction and elevation as given in the initial fire command. He does not need to refer to a firing table for the remainder of the mission. Following the initial fire command, he makes no attempt to align the sight on the aiming point. Corrections for deviation are made by applying the turns given in the subsequent commands. Range changes for the 4.2-inch mortar are made by varying the number of propellant increments (charges).
- c. In the bracketing method and ladder method of adjustment, once the FO obtains a bracket on the target, he does not need a firing table. He continues the adjustment by splitting successively the charge difference that established the preceding bracket.

8-27. FIRE CONTROL

The squad leader controls the fire from an OP, issuing fire commands directly to the mortar crew. He may select an OP close to the mortar so that he can give his fire commands orally or by arm-and-hand signals. When the OP is not close to the mortar position, he uses a telephone or radio.

8-28. ESTABLISHMENT OF A REFERENCE LINE AND SHIFTING FROM THAT LINE

The normal method of establishing initial direction when operating without an FDC is the direct--alignment method. After initial direction has been established, the FO should conduct a registration using only the direction stake. After he completes this registration, he establishes the GT line as a reference line. This is accomplished by referring the sight to the desired deflection (usually 3200 mils) and then realigning the direction stake on

this deflection. The following is an example of the FO located within 100 meters of the mortar position.

a. An FO has adjusted the fire of his squad on a target. A reference line has been established at 3200 mils on the azimuth scale. The FO observes another target and decides to adjust onto it. He estimates the GT range to be 1,800 meters, determines with his binoculars that the target is 60 mils to the right of the first target or registration point, and issues an initial fire command:

**NUMBER ONE
HE QUICK
ONE ROUND
THREE ROUNDS IN EFFECT
FROM REGISTRATION POINT, RIGHT SIX ZERO (60)
RANGE ONE EIGHT ZERO ZERO (800)**

The gunner sets his sight with a deflection of 3200 mils and applies the LARS rule (60 mils subtracted from 3200 mils equals a deflection of 3140). Looking at the FT, he finds the charge to be 9 5/8 at elevation 0900. He announces the charge to the ammunition bearer, and at the same time places the elevation on the sight. He lays the mortar and commands, FIRE.

b. This first round bursts beyond the target and 20 mils to the left as shown in Figure 8-5. The squad leader issues a subsequent fire command correcting the deflection and decreasing the range between himself and the target, thereby establishing a bracket. He commands, RIGHT TWO ZERO (20), RANGE ONE SIX ZERO ZERO (1600).

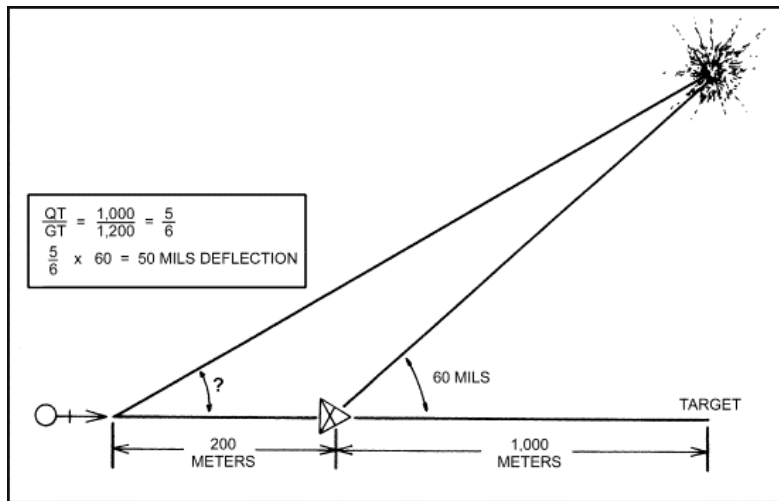

Figure 8-5. Observer more than 100 meters from the mortar but within 100 meters of the GT line.

c. The second round bursts between the FO and target and on the GT line as shown in Figure 8-5. The deflection is now correct, and a 200-meter bracket has been established. The squad leader's subsequent fire command is RANGE, ONE SEVEN ZERO ZERO (1700). The gunner selects the charge from his firing table, announces the charge to the first ammunition bearer, and when all is ready he commands, FIRE.

d. This third round bursts beyond the target and on the GT line (Figure 8-4). A 100-meter range bracket has now been established. In his next fire command, the squad leader combines the adjustment with FFE:

THREE ROUNDS
RANGE, ONE SIX FIVE ZERO (1650)

e. The bursting area of these rounds and their normal dispersion cover the target area with casualty-producing fragments. If the FFE fails to cover the target adequately, the squad leader makes any necessary changes in deflection or range and again orders FFE. This adjustment can also be fired using modified fire commands.

f. Modified fire commands for this mission are as follows:

NUMBER ONE
HE QUICK
ONE ROUND
THREE ROUNDS IN EFFECT
FROM RP
RIGHT SIX ZERO (60)
CHARGE 9 5/8
ELEVATION ZERO NINE ZERO ZERO (0900)

RIGHT TWO TURNS
CHARGE 8 4/8

CHARGE 9

THREE ROUNDS
CHARGE 8 6/8

8-29. LADDER METHOD OF ADJUSTMENT

Since surprise is an important factor in placing effective fire on a target, any form of adjustment that reduces the time interval between the burst of the first round for adjustment and FFE is useful. The ladder method of adjustment, a modification of the bracketing method, reduces the time interval and permits FFE to be delivered rapidly. The ladder method may also be used by the FO when firing with an FDC (Figure 8-6).

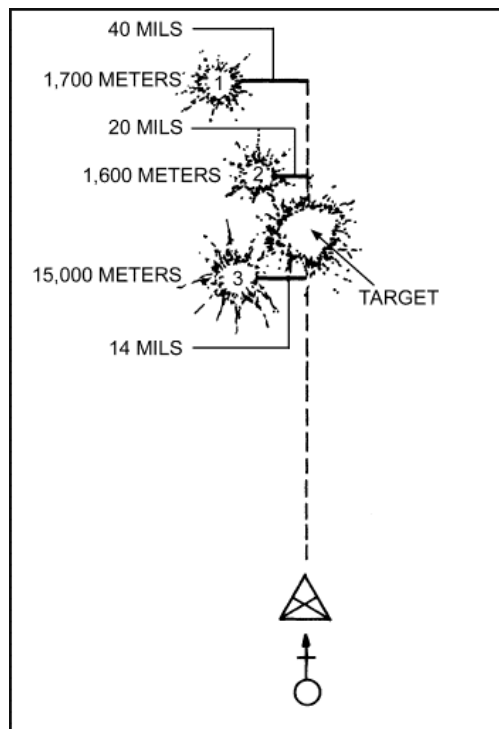

Figure 8-6. Ladder method of fire adjustment.

Note: In the following example, the FO is located within 100 meters of the mortar position.

a. The FO measures the deviation of a target from the registration point as right 30 mils. He estimates the GT range to be 1,600 meters. The size of the ladder is based on the minimum range change guide. To obtain a 200-meter ladder, the FO adds 100 meters to this estimated range to establish one range limit for the ladder and subtracts 100 meters from the estimated range to establish the other limit. This should result in a ladder that straddles the target. Three rounds are fired in this sequence: far, middle, and near at 10-second intervals. This helps the FO make a spotting, since no burst is obscured by the dust and smoke from a preceding burst. The FO checks his firing table to obtain the charge for the far range, 1,700 meters (charge 9); the middle range, 1,600 meters (charge 8 $\frac{4}{8}$); and the near range, 1,500 meters (charge 8), and issues the following initial fire command:

NUMBER ONE
HE QUICK
FIVE ROUNDS IN EFFECT
100-METER LADDER
FROM REGISTRATION POINT, RIGHT THREE ZERO (30)
ONE ROUND, CHARGE 9
ONE ROUND, CHARGE 8 4/8
ONE ROUND, CHARGE 8
ELEVATION ZERO NINE ZERO ZERO (0900)

b. This method of fire element in the normal initial fire command for the ladder contains the word "ladder." The elevation element gives the constant elevation to conduct the mission. The word "ladder" tells the gunner that three rounds will be fired as follows: the first at the charge announced (far range), the second at the announced middle charge, and the third at the last announced charge. The gunner indexes his sight for deflection at the base deflection minus 30, while the first ammunition bearer prepares the rounds with the designated charges.

c. The average deviation of all three rounds is left 30 mils. The target is bracketed between second and third bursts. The squad leader now has a 100-meter bracket of the target between 1,500 and 1,600 meters, and is ready to FFE. He issues the following subsequent fire command:

FIVE ROUNDS
RIGHT THREE TURNS
CHARGE 8 2/8

CHAPTER 9

GUNNER'S EXAMINATION

The gunner's examination tests the proficiency of the gunner. It is also a test of the three qualified assistants whom the candidate is allowed to choose. The candidate's success in the examination depends mainly on his ability to work harmoniously with these assistants. The examining board must consider this factor and ensure uniformity during the test. Units should administer the gunner's examination at least semiannually to certify crew proficiency.

Section I. PREPARATORY INSTRUCTION

Preparatory instruction for the gunner's examination teaches the soldier how to properly and accurately perform the gunner's duties. The squad leader is responsible for this preparation instruction. In TOE units, squad members should be rotated within the squad so that each member can become proficient in all squad positions. Individual test scores should be maintained; squad scores should be determined and compared with other squads to build esprit de corps.

9-1. METHODS OF INSTRUCTION

The applicability method of instruction is used for the gunner's examination.

- a. The conditions and requirements of each step of the qualification course are explained and demonstrated. Then each candidate is given practical work and is constantly supervised by his squad leader to ensure accuracy and speed-accuracy is stressed from the start; speed is attained through repetition.
- b. The platoon leader/platoon sergeant monitors the instruction given by the squad leaders within the platoon. Demonstrations are usually given to the entire group. Also, squads perform practical work under the supervision of the squad leader.

9-2. PRIOR TRAINING

A soldier must be proficient in mechanical training, crew drill, and fire commands and their execution before he qualifies to take the examination.

9-3. PREPARATORY EXERCISES

The preparatory exercises for the gunner's examination consist of training in those steps found in the qualification course. After sufficient preparatory exercises, candidates are

given the gunner's examination. Those failing the examination should be retrained for testing at a later date.

9-4. EXAMINING BOARD

The examining board consists of one officer and two senior NCOs who are proficient with the weapon. Not more than one member is selected from officers who are assigned to the candidate's organization. (The commander having authority to issue special orders appoints the board.) Scores are recorded on DA Form 5964-R (Gunner's Examination Scorecard) (Figure 9-1). A blank copy of this form is located in the back of this publication for local reproduction on 8 1/2-inch by 11-inch paper.

GUNNER'S EXAMINATION SCORECARD - MORTARS
For Use by Units and for the Candidate's Use - MORTARS

MORTAR CLASS - ()
 Career Mounted
 Career Mounted
 Support Squad

DATA REQUIRED BY THE PRIVACY ACT OF 1974

Authority: 10 USC 3012 (a) - Executive Order 13526
Principal Purpose: Evaluate individual's training in mortar
Routine Use: Evaluate individual's training in mortar
Disclosure: Disclosure of this information is mandatory. However, individuals are provided information control in accordance with a class name.

7. ORGANIZATION: HHC 1ST BN (MECH) 66th INF
 NAME (Last, First, MI): DOE, JOHN, J.
 CHECK ONE: M224 M252 M256 M260 M261

8. DATE: 10 MAY 90
9. GRADE: E-4
10. UIC: 000-00-4808

ITEM	How to Score	TOTAL SCORE		CREDIT SCORE	REMARKS
		1st	2nd		
8. Ground Mounting and Firing the Mortar and Position from Steady Position	1st Trial 2nd Trial	58 53	9 9	18	T.B.
9. Air - Small Deflection Change	1st Trial 2nd Trial	13 8	8 10	18	P.L.
10. Ground and Center - Receiving the M224 and Mapping during Zero Support direct firing	1st Trial 2nd Trial	70 73	9 9	19	P.A.
11. Air - Large Deflection and Mission Change	1st Trial 2nd Trial	38 40	8 8	16	H.W.
12. Ground and Center - Receiving M224 Support - Launch by Central	1st Trial 2nd Trial	47 44	9 10	19	H.H.
13. TOTAL CREDIT SCORE				90	

14. VERIFIED BY:
 IDENTIFIED NAME: 1LT JOHN P. ONLY
 SIGNATURE: [Signature]
 GRADE: S-2
 ORGANIZATION: HHC 1st Bn (Mech) 66th Inf
 DATE: 10 MAY 90

DA FORM 5964-R, SEP 80

Figure 9-1. Example of completed DA Form 5964-R.

9-5. LOCATION AND DATE

Each unit armed with a mortar weapon system gives examinations semiannually. Other units may conduct examinations or allow their eligible members to take the qualification

tests at nearby stations. (The commander authorized to issue special orders determines the date of the examination.) The area selected should be on flat terrain consisting of soil that allows for aiming posts to be easily positioned at 50 and 100 meters from the station position.

9-6. ELIGIBLE PERSONNEL

The following personnel are eligible to take the examination:

- Commissioned officers and enlisted men assigned to a mortar unit.
- Commissioned officers and enlisted men whose duties require them to maintain proficiency in the use of mortars, as determined by battalion and higher commanders.

9-7. QUALIFICATION SCORES

A candidate's earlier qualification ends when he is administered a record course with the mortar. He is classified according to his latest examination score as follows:

- Expert gunner 90 - 100
- First-class gunner 80 - 89
- Second-class gunner 70 - 79
- Unqualified 69 or less

9-8. GENERAL RULES

Conditions should be the same for all candidates during the test. The examining board ensures that information obtained by a candidate during testing is not passed to another candidate, and that candidates do not receive sight settings or laying of mortars left by a previous candidate.

- a. Unit equipment should be used in the examination; however, it should be the best available. Sight settings are considered correct when any part of the index coincides with any part of the line of graduation of the required setting.
- b. The left side of the aiming post is used for alignment. The elevation and cross-level bubbles are considered centered when the bubbles are resting entirely within the outer etched lines on the vials.
- c. The candidate is permitted to traverse the mortar to the middle point of traverse before each trial at laying the mortar, except at Station No. 5.

d. In any test that calls for mounting or emplacing the mortar, either by the candidate or the board, the surface emplacement is used. Digging is not allowed, and the rear of the baseplate assembly is not staked.

e. In time trials, the candidate does not receive credit for the trial if he performs any part of it after announcing, "Up."

f. The candidate selects his assistants from within his squad to participate in the test. When squad members are unavailable for testing, the candidate may select his assistants from outside the squad but from within his organization. The board makes sure that no unauthorized assistance is given the candidate during the examination.

g. A candidate is given three trials--one for practice and two for record. If he takes the first trial for record, then he must take the second trial for record even if he fails it. His credit score is the total of the two trials. When he fails in any trial through the fault of an examiner, defective sight, mortar, mount, or other instrument used, that trial is void and the candidate is given another trial as soon as possible. If his actions cause the mortar to function unsatisfactorily during testing, he receives no credit for that portion of the test.

h. When there is a mechanical failure and a mortar fails to maintain the lay after the candidate announces, "Up," a board member twists or pushes the mortar (taking up the play without manipulation) until the cross-level bubble is within the two outer etched lines. He then looks through the sight and if the vertical line is within two mils of the correct sight picture, the candidate is given credit for that trial, as long as other conditions are met.

i. The candidate must repeat all commands. Commands should be varied between trials, using even and odd numbers, and right and left deflections.

Section II. GUNNER'S EXAMINATION WITH GROUND-MOUNTED MORTAR

This examination tests the gunner's ability to perform basic mortar gunnery tasks with the ground-mounted mortar system.

9-9. SUBJECTS AND CREDITS

The examination consists of the following tests with maximum credit scores as shown.

Mounting the mortar	20 points
Small deflection change	20 points
Referring the sight and realigning aiming posts	20 points

Reciprocal laying

20 points

9-10. EQUIPMENT

The recommended equipment needed for the five stations includes 5 mortars, 5 sights, 1 aiming circle, 8 aiming posts, 5 stopwatches, and 16 filled sandbags or ammunition boxes (4.2-inch only).

9-11. ORGANIZATION

The organization prescribed in Table 9-1 is recommended for the conduct of the gunner's examination. Variations are authorized, depending on local conditions and the number of men being tested.

STATION	PHASE	EQUIPMENT	
		FOR CANDIDATE	FOR EXAMINING OFFICER
1	Mounting the mortar.	1 mortar 1 sight 2 sandbags (4.2-inch only) 1 baseplate stake	1 stopwatch
2	Small deflection change.	1 mortar 1 sight 2 sandbags (4.2-inch only) 2 aiming posts	1 stopwatch
3	Referring the sight.	1 mortar 1 sight 4 sandbags (4.2-inch only) 2 aiming posts	1 stopwatch
4	Large deflection and elevation change.	1 mortar 1 sight 4 sandbags (4.2-inch only) 2 aiming posts	1 stopwatch
5	Reciprocal laying.	1 mortar	1 stopwatch

		1 sight 4 sandbags (4.2-inch only) 2 aiming posts	1 aiming circle
--	--	--	-----------------

Table 9-1. Organization for conducting gunner's examination (ground-mounted).

9-12. PROCEDURE

The candidate carries his scorecard (Figure 9-1) from station to station. The evaluator at each station fills in the time, trial scores, and credit score, and initials the appropriate spaces.

9-13. MOUNTING OF THE MORTAR

The candidate is tested at station No. 1 on his ability to perform the gunner's duties in mounting the mortar.

a. **Equipment.** Prescribed in Table 9-1.

b. **Conditions.** The candidate is directed to mount the mortar with his authorized assistants. The conditions of the test are as follows:

(1) (*All mortars*) The candidate arranges his equipment as outlined in Figures 9-2 through 9-6. The emplacement is marked before the examination.

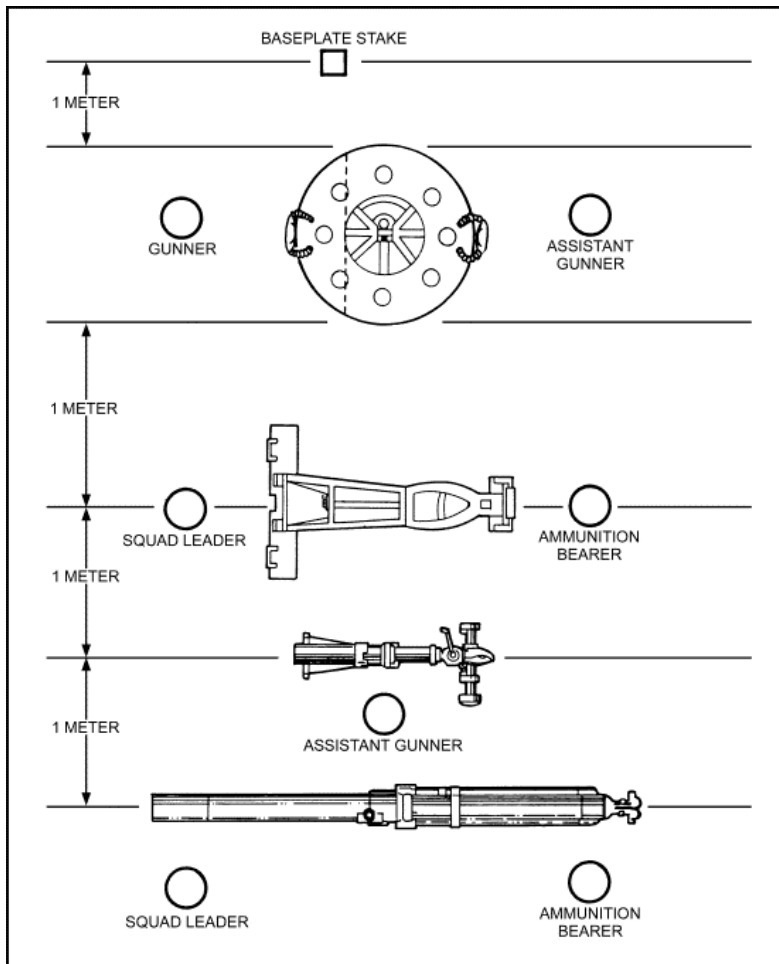

Figure 9-2. Diagram of equipment layout and position of personnel for the gunner's examination (4.2-inch mortar).

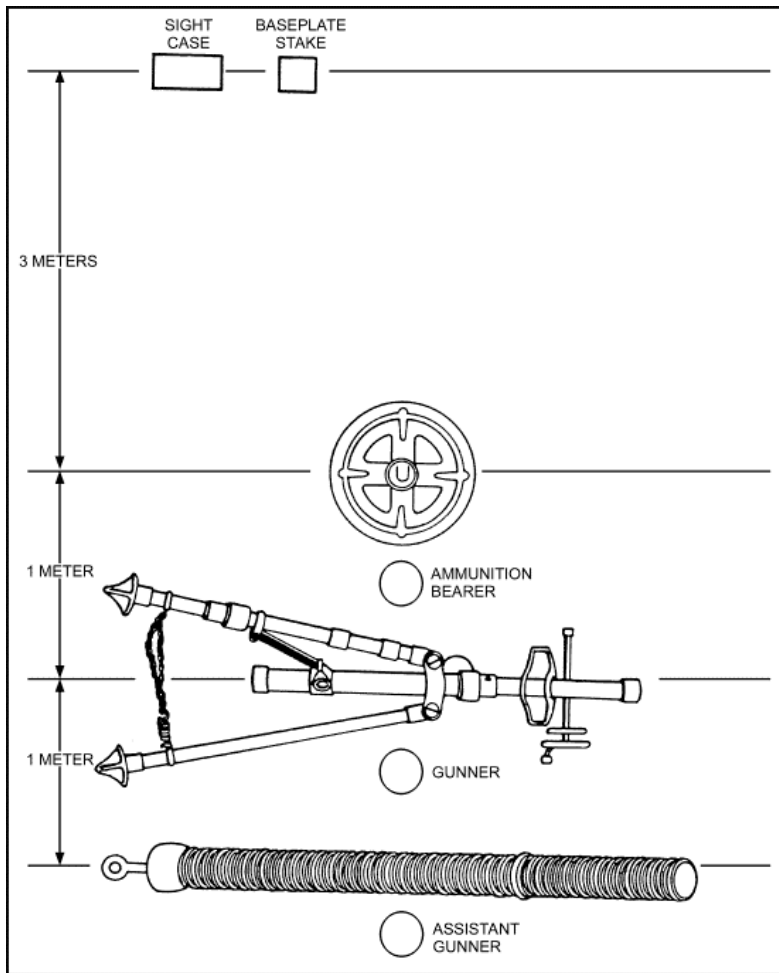

Figure 9-3. Diagram of equipment layout and position of personnel for the gunner's examination (81-mm mortar, M29A1).

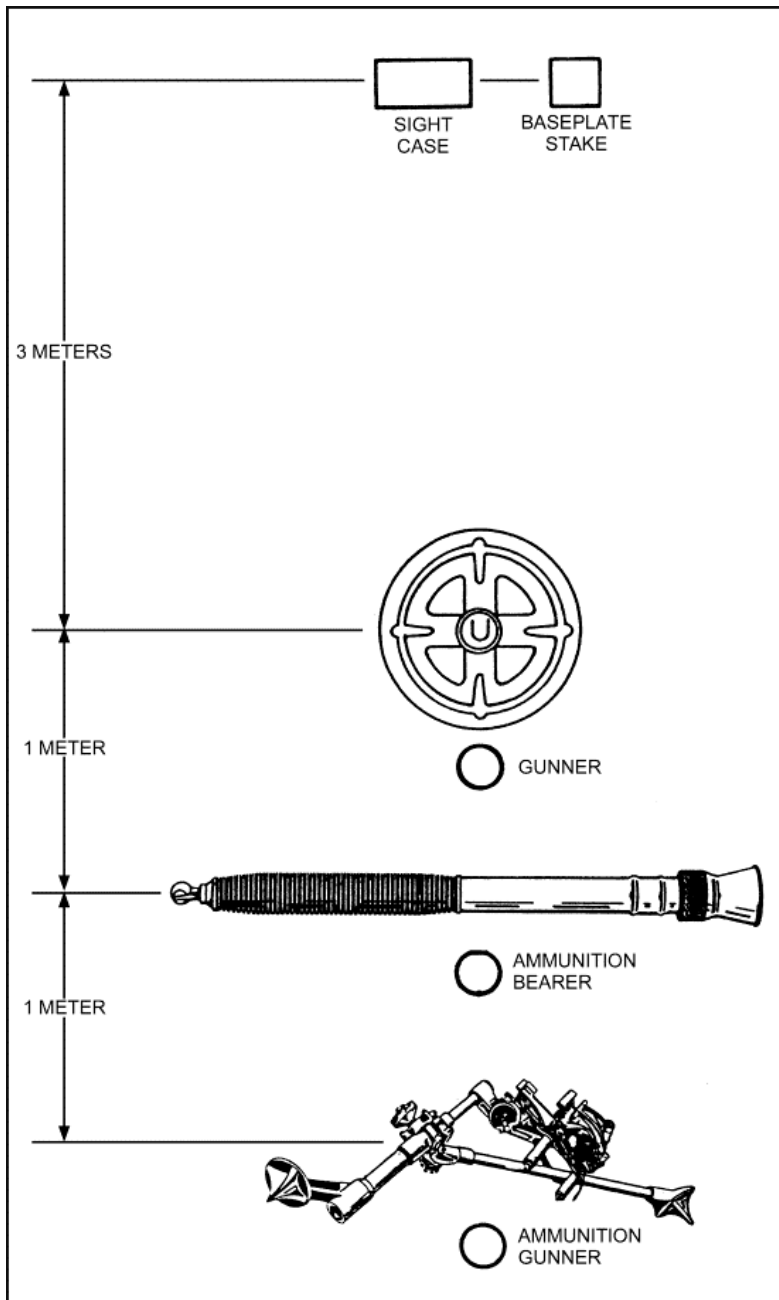

Figure 9-4. Diagram of equipment layout and position of personnel for the gunner's examination (81-mm mortar, M252).

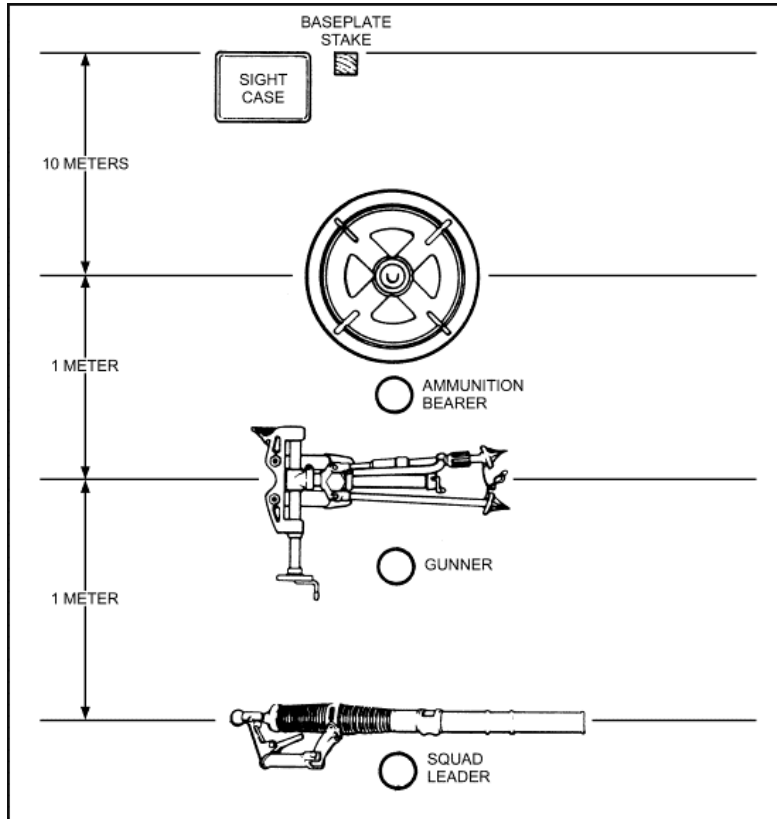

Figure 9-5. Diagram of equipment layout and position of personnel for the gunner's examination (60-mm mortar).

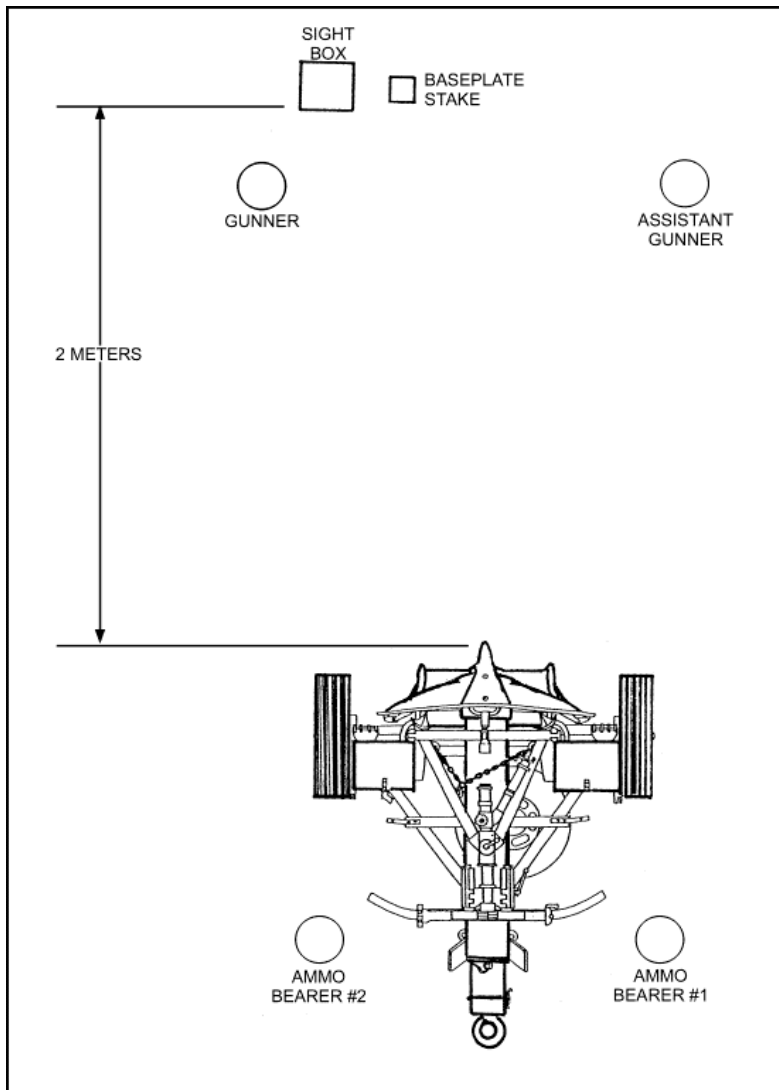

Figure 9-6. Diagram of equipment layout and position of personnel for the gunner's examination (120-mm mortar).

(2) *(All mortars)* The mortar sight is seated in its case with 3800 mils (3200 mils for the M64 sights) set on the deflection scale and 0800 mils set on the elevation scale, and the sightbox is closed and latched.

(3) *(4.2-inch only)* The two sandbags or ammunition boxes are placed under the spade to prevent the baseplate assembly from tilting. They are in position at the start of the examination.

(4) *(4.2-inch only)* The standard assembly is in low range at its lowest elevation, with the traversing assembly side traversed all the way to the right with the crank closed.

(5) *(4.2-inch only)* The mortar locking pin is fully inserted and locked.

(6) *(All mortars except 4.2-inch)* The candidate should examine the equipment before mounting.

(7) *(120-mm only)* Traverse extension is locked and centered.

c. Procedure. The candidate is given two trials; his credit score is the total of these two trial scores.

(1) The candidate and his assistants take their positions. The candidate is instructed to mount the mortar at 3200 mils deflection and 900 mils elevation for the 4.2-inch mortar, or 3200 mils deflection and 1100 mils elevation for all other mortars.

Note: When using the M53 series sightunit, the red deflection scale is used for all laying procedures.

(2) The evaluator points to the exact spot where the mortar is to be mounted. He indicates the initial direction of fire by pointing in that direction and gives the command ACTION, at which time the candidate begins mounting the mortar. After mounting the mortar, he should have 3200 mils deflection and 900 mils elevation on the sight for the 4.2-inch mortar or 1100 mils elevation and 3200 mils deflection for all other mortars.

(3) The assistants may manipulate the sight mount knob and elevation crank. They may center the connection for the mortar locking pin assembly, but they **MUST NOT** manipulate the sight for deflection or elevation settings.

(4) When the test is completed, the candidate announces, "Up." Time is charged against him from the command ACTION to the announcement "Up."

d. **Scoring.** Scoring procedures are as follows:

(1) The candidate receives no credit when the--

- Time exceeds 1 minute, 40 seconds (4.2 inch only); time exceeds 1 minute and 15 seconds (120-mm only); time exceeds 90 seconds (all other mortars).
- Sight is not set correctly for deflection and elevation.
- Cross-level and elevation bubbles are not centered.
- Mortar locking pin, or the clevis lock pin is not fully locked.
- Connection for the mortar locking pin assembly (buffer carrier, 60-mm mortar) or the traversing slide assembly is off center more than two turns.
- Assistant manipulates the sight for a deflection or elevation setting.
- The baseplate is not positioned correctly in relation to the baseplate stake.
- The selector switch on the barrel is not on D for drop-fire (60-mm mortar only).
- The collar assembly is not positioned on the lower saddle (60-mm mortar only).
- Firing pin recess is not facing upwards on the barrel (81-mm mortar, M252 only).
- Traverse is more than four turns (120-mm only).
- Barrel clamp is not locked (120-mm only).
- Cross-level lock is not tight (120-mm only).
- Leg-locking handwheel is not wrist-tight (81-mm mortar, M252 only).
- The coarse cross-level nut is not wrist-tight (60-mm and 81-mm, M29A1, mortars only).
- The collar locking knob is not secured (hand-tight) to the barrel (60-mm and 81-mm, M252, mortars only).
- The bipod legs are not fully extended and the spread cable or chain is not taut (60-mm; 81-mm, M29A1; and 120-mm mortars only).

(2) When the mortar is correctly mounted within the prescribed limits, credit is given as follows:

TIME
(seconds)

POINT CREDIT
FOR EACH TRIAL

120-mm	4.2-inch Mortar	All Other Mortars	
51 or less	50 or less	65 or less	10
52 to 57	51 to 60	66 to 70	9
58 to 63	61 to 70	71 to 75	8
64 to 69	71 to 80	76 to 80	7
70 to 75	81 to 90	81 to 85	6
	91 to 100	86 to 90	5
76 or over	101 or over	91 or over	0

9-14. SMALL DEFLECTION CHANGE

The candidate is tested at station No. 2 on his ability to perform the gunner's duties when he is given commands that require a change in deflection.

a. **Equipment.** Prescribed in Table 9-1.

b. **Conditions.** A mortar is mounted with the sight installed. The sight is laid on two aiming posts (placed out 50 to 100 meters from the mortar) on a referred deflection of 2800 mils and 900 mils elevation for the 4.2-inch mortar, and 2800 mils deflection and 1100 mils elevation for all other mortars. The mortar is center of traverse, and the vertical line of sight is on the left edge of both aiming posts.

(1) The candidate is allowed to check the deflection set on the sight before each trial.

(2) He is allowed to start each trial with his hand on the deflection knob. (The assistant may start with his hand on the sight mount knob [4.2-inch only]).

(3) The change in deflection does not involve movement of the bridge assembly but causes the candidate to traverse the mortar at least 50 mils and not more than 75 mils (4.2-inch) and at least 20 mils and not more than 60 mils (all mortars except 4.2-inch).

(4) Traversing extension is locked and centered (120-mm).

c. **Procedure.** The candidate is given two trials; his credit score is the total of these two trials.

(1) The candidate is given one assistant. A different command is given for each trial. The evaluator records the time and checks the candidate's work after each command has been executed.

(2) The evaluator announces an initial command requiring a change in deflection of 50 to 75 mils for the 4.2-inch mortar. All other mortars require a change in deflection of 20 to 60 mils and an elevation change of 35 to 90 mils. The candidate may proceed with the exercise as soon as the deflection element is announced. The evaluator announces the command in normal sequence and cadence.

(3) No manipulation by the assistant is allowed except for cross-leveling on the 4.2-inch mortar.

(4) Time is charged against the candidate from the announcement of the last digit of the elevation element until the candidate announces, "Up."

d. Scoring. Scoring procedures are as follows:

(1) The candidate receives no credit when the--

- Time exceeds 20 seconds (4.2-inch); time exceeds 76 seconds (120-mm); time exceeds 35 seconds (all other mortars).
- Sight is not set correctly for deflection or elevation.
- Elevation bubble is not centered.
- Cross-level bubble is not centered.
- Assistant manipulates the mortar or sight for elevation or deflection.
- Vertical cross line of the sight is more than 2 mils off the correct sight picture.

(2) When the mortar is laid correctly within the prescribed limits, credit is given as follows:

TIME (seconds)			POINT CREDIT FOR EACH TRIAL
120-mm	4.2-inch Mortar	All Other Mortars	
20 or less	8 or less	20 or less	10
21 to 23	9 to 11	21 to 23	9

24 to 26	12 to 14	24 to 26	8
27 to 31	15 to 17	27 to 31	7
32 to 35	18 to 20	32 to 35	6
36 or over	21 or over	36 or over	0

9-15. REFERRING OF THE SIGHT AND REALIGNMENT OF AIMING POSTS

The candidate is tested at station No. 3 on his ability to perform the gunner's duties in referring the sight and realigning the aiming posts.

a. **Equipment.** Prescribed in Table 9-1.

b. **Conditions.** The mortar is mounted with the appropriate or proper sight installed. The sight is laid on two aiming posts (placed out 50 and 100 meters from the mortar) on a referred deflection of 2800 mils and 900 mils elevation for the 4.2-inch mortar, and 2800 mils deflection and 1100 mils elevation for all other mortars.

(1) The mortar is within two turns of center of traverse (four turns for the 120-mm). The candidate receives an administrative command with a deflection of 2860 or 2740 mils. The mortar is then re-laid on the aiming posts using the traversing crank.

(2) The candidate checks the conditions before each trial and is allowed to start the test with his hand on the deflection knob of the sight.

(3) The change in deflection in the command must be less than 25 mils but greater than 5 mils. The elevation remains constant at 900 or 1100 mils.

(4) The candidate is allowed two assistants—one to place out aiming posts and one to move the bridge or bipod (mount) and to cross-level. The assistants do not manipulate the sight or mortar for elevation or deflection.

(5) Traverse extension will not be used. It will remain locked in the center position.

c. **Procedure.** The candidate is given two trials; his credit score is the total of these two trials.

(1) A different command is given for each trial. The evaluator records the time and checks the candidate's work after each command has been executed.

(2) When the candidate is ready, he is given a command--for example, REFER, DEFLECTION TWO EIGHT EIGHT ZERO (2880), REALIGN AIMING POSTS.

(3) The candidate repeats each element of the command, sets the sight with the data given in the command, and directs one assistant in realigning the aiming posts. Then he centers his traversing assembly and, with the help of the assistant gunner, moves the bridge or bipod (mount) assembly and re-lays on his aiming posts. After he lays the mortar on the realigned posts, he announces, "Up."

Note: This procedure ensures that, after a registration mission (using a parallel sheaf), the mortars have matching deflections.

(4) Time is taken from the announcement of refer and align aiming post to the candidate's announcement of "Up."

(5) The candidate's assistant may not leave the mortar position until he hears the word POSTS in the command REALIGN AIMING POSTS.

d. Scoring. Scoring procedures are as follows:

(1) No credit is given when the--

- Time exceeds 1 minute, 40 seconds (4.2-inch only); time exceeds (120-mm only); time exceeds 1 minute, 15 seconds (all other mortars).
- Traversing crank is turned before the aiming posts are realigned.
- Sight is not set correctly for deflection or elevation.
- Mortar is not cross-leveled or correctly laid for elevation.
- Vertical line of the sight is more than 2 mils off the correct sight picture.
- Traversing assembly slide is more than two turns (four turns for the 120-mm) to the left or right of the center position.
- Assistant manipulates the sight or mortar for elevation or deflection.

(2) When the mortar is found to be correctly laid within the prescribed limits, credit is given as follows:

**TIME
(seconds)**

**POINT CREDIT
FOR EACH TRIAL**

120-mm	4.2-inch Mortar	All Other Mortars	
60 or less	70 or less	60 or less	10
61 to 65	71 to 80	61 to 65	9
66 to 70	81 to 90	66 to 70	8
71 to 75	91 to 100	71 to 75	7
76 or over	101 or over	76 or over	0

9-16. LARGE DEFLECTION AND ELEVATION CHANGES

The candidate is tested at station No. 4 on his ability to perform the gunner's duties when he is given commands requiring a large change in deflection and elevation.

a. **Equipment.** Prescribed in Table 9-1.

b. **Conditions.** A mortar is mounted with the sight installed. The sight is laid on two aiming posts placed out 50 to 100 meters from the mortar on a referred deflection of 2800 mils (1100 mils elevation for the 120-mm). For the first trial, using the 4.2-inch mortar, 900 mils elevation (low range) is used; for the second trial, 1065 mils elevation (high range) is used (for all mortars but the 4.2-inch, the elevation change will be greater than 100 mils but less than 200 mils). The mortar is within two turns of center of traverse (four turns for the 120-mm).

(1) The candidate is allowed to check the deflection and elevation setting before each trial. He is allowed to start each trial with his hand on the deflection knob.

(2) The change in deflection involves movement of the bridge or bipod assembly and causes the candidate to shift the barrel not less than 200 mils and not more than 300 mils. The change in elevation causes him to elevate or depress the barrel from low range to high range, or vice versa.

(3) Traverse extension is locked and centered (for the 120-mm).

c. **Procedure.** The candidate is given two trials; his credit score is the total of these two trials.

(1) The candidate is given two assistants--one assistant may visually align the mortar while the other shifts the bridge and standard assemblies. The assistants neither manipulate the sight nor lay the mortar for deflection. A

different command is given for each trial. The evaluator records the time and checks the candidate's mortar after each command has been executed.

(2) The evaluator announces a command that requires a change in deflection and elevation, involving movement of the bridge assembly and a change in the elevation range--for example: NUMBER ONE, HE QUICK, ONE ROUND, DEFLECTION THREE ZERO FOUR FIVE (3045), CHARGE TWO FOUR (24), ELEVATION ONE ZERO SIX FIVE (1065).

(3) The candidate repeats each element of the command. As soon as the deflection element is given, he places the data on the sight and re-lays on the aiming point with a compensated sight picture. As soon as the mortar is laid, he announces, "Up." The assistants must remain in their normal positions until the deflection element is given.

(4) Time is taken from the announcement of the last digit of the elevation element of the fire command until the candidate announces, "Up."

d. Scoring. Scoring procedures are as follows:

(1) The candidate receives no credit when the--

- Time exceeds 1 minute and 15 seconds (60-mm mortar); time exceeds 55 seconds (120-mm); time exceeds 60 seconds (all other mortars).
- Sight is not set correctly for deflection or elevation.
- Mortar is not correctly laid for elevation.
- Mortar is not cross-leveled.
- Vertical line is more than 2 mils off the compensated or aligned sight picture.
- Traversing assembly slide is more than two turns (four turns for the 120-mm) to the left or right of the center position.
- Assistants make unauthorized movements or manipulations.
- Collar assembly is not positioned on the correct saddle for the announced elevation (60-mm).
- Traverse extension is not locked and centered (for the 120-mm).

(2) When the mortar is laid correctly within the prescribed limits, credit is given as follows:

**TIME
(seconds)**

**POINT CREDIT
FOR EACH TRIAL**

120-mm	4.2-inch Mortar	All Other Mortars	
35 or less	40 or less	35 or less	10
36 to 40	41 to 47	36 to 40	9
41 to 45	48 to 54	41 to 45	8
46 to 50	55 to 61	46 to 50	7
51 to 55	62 to 68	51 to 55	6
	70 to 75	56 to 60	5
56 or over	76 or over	61 or over	0

9-17. RECIPROCAL LAYING

The candidate is tested at station No. 5 on his ability to perform the gunner's duties in laying a mortar for direction.

a. **Equipment.** Prescribed in Table 9-1.

b. **Station Setup.** The evaluator sets up the aiming circle about 25 meters to the left front of the station. He levels the instrument and orients the aiming circle so that the 0-3200 line is in the general direction the mortar is mounted. A direction stake is placed out about 25 meters in front of the mortar position.

c. **Conditions.** The candidate is given one assistant to shift the bridge or bipod assembly. The assistant does not manipulate the sight or mortar in laying for elevation or deflection. The conditions of the test are as follows:

(1) The 4.2-inch mortar is mounted for the candidate at 900 mils elevation, 3200 mils deflection. All other mortars are mounted at 3200 mils deflection and 1100 mils elevation. The mortar is laid on a direction stake on the initial mounting azimuth with the traversing mechanism centered.

(2) The mounting azimuth on which the candidate is ordered to lay the mortar is not less than 150 mils or more than 200 mils away from the initial mounting azimuth.

(3) The evaluator sets up the aiming circle about 25 meters to the left front of the mortar, with the instrument leveled and the 0-3200 line already on the mounting azimuth on which the mortar is to be laid.

(4) The candidate is allowed to start the test with his hand on the deflection knob. The assistants must remain in their normal positions until the evaluator gives the first deflection element.

(5) Traverse extension is locked and centered (for the 120-mm).

d. **Procedure.** The candidate is given two trials; his credit score is the total of these two trial scores.

(1) The evaluator operates the aiming circle during this test. He lays the vertical line on the mortar sight and commands AIMING POINT THIS INSTRUMENT.

(2) The candidate refers his sight to the aiming point and replies AIMING POINT IDENTIFIED.

(3) The evaluator then announces the deflection--for example, "Number one, deflection two three one five (2315)."

(4) The candidate repeats the announced deflection, sets it on his sight, and lays the mortar on the center of the aiming circle lens. He then announces, "Number one ready for recheck." The evaluator announces the new deflection immediately so that there is no delay.

(5) The operation is completed when the candidate announces, "Number one, zero (or one) mil(s), mortar laid."

(6) Time is taken from the last digit of elevation first announced by the evaluator until the candidate announces, "Number one, zero (or one) mil(s), mortar laid."

e. **Scoring.** Scoring procedures are as follows:

(1) The candidate receives no credit when the--

- Time exceeds 1 minute, 55 seconds.
- Sight is not set correctly for deflection or elevation.
- Elevation bubble is not centered.
- Cross-level bubble is not centered.
- Vertical line of the sight is not centered on the aiming circle lens.
- The mortar sight and the aiming circle deflection difference exceeds 1 mil.
- Assistant performs unauthorized manipulations or movements.
- Traversing mechanism is more than two turns (four turns for the 120-mm) from center of traverse. Traverse extension is not locked in the center position.

(2) When the mortar is laid correctly within the prescribed limits, credit is given as follows:

TIME (seconds)	POINT CREDIT FOR EACH TRIAL
55 or less	10
56 to 67	9
68 to 79	8
80 to 91	7
92 to 103	6
104 to 115	5
116 or over	0

Section III. GUNNER'S EXAMINATION WITH THE TRACK-MOUNTED MORTAR

This examination tests the gunner's ability to perform basic mortar gunnery tasks with the track-mounted mortar system.

9-18. SUBJECTS AND CREDITS

The examination consists of the following tests with maximum credit scores as shown.

Placing the mortar into a firing position from the traveling position	20 points
Small deflection change	20 points
Referring the sight and realigning the aiming posts	20 points
Large deflection and elevation changes	20 points
Reciprocally laying	20 points

9-19. EQUIPMENT

The minimum equipment needed for the five stations includes five mortars, five M106-series carriers, five sights, one aiming circle, eight aiming posts, and five stopwatches.

9-20. ORGANIZATION

The organization prescribed in Table 9-2 is recommended for the conduct of the gunner's examination. Variations are authorized, depending on local conditions and the number of men being tested.

STATION	PHASE	EQUIPMENT	
		FOR CANDIDATE	FOR EXAMINING OFFICER
1	Placement of the mortar into firing position from the traveling position.	1 mortar carrier 1 mortar 1 sight	1 stopwatch
2	Small deflection change.	1 mortar carrier 1 mortar 1 sight 2 aiming posts	1 stopwatch
3	Referring of the sight and realignment of the aiming posts.	1 mortar carrier 1 mortar 1 sight 2 aiming posts	1 stopwatch
4	Large deflection and elevation changes.	1 mortar carrier 1 mortar 1 sight 2 aiming posts	1 stopwatch
5	Reciprocal laying.	1 mortar carrier 1 mortar 1 sight 2 aiming posts	1 stopwatch 1 aiming circle

Table 9-2. Organization for conducting gunner's examination (carrier-mounted).

9-21. PROCEDURE

The candidate carries his scorecard from station to station. The evaluator at each station fills in the time, trial scores, and credit score, and initials the appropriate spaces.

9-22. PLACEMENT OF MORTAR INTO A FIRING POSITION FROM TRAVELING POSITION

The candidate is tested at station No. 1 on his ability to perform quickly and accurately the gunner's duties in placing the mortar into the firing position from the traveling position.

a. **Equipment.** Prescribed in Table 9-2.

b. **Conditions.** The mortar is secured in the traveling position by the mortar tie-down strap.

- (1) The sight is in its case, and the case is in its stowage position.
- (2) The candidate selects an assistant gunner.
- (3) The blast attenuator device is removed and stored properly for the 120-mm mortar system.
- (4) The mortar hatch covers are closed and locked (the ramp may be in the up or down position).
- (5) The gunner and assistant gunner are seated in their traveling positions.
- (6) The evaluator ensures that the candidate understands the requirement of the test and instructs him to report I AM READY before each trial.

c. **Procedure.** The candidate is given two trials; his credit score for the test is the total of these two trials.

Note: The traverse extension (120-mm) is not used during the gunner's examination. It remains locked in the center position.

(1) The evaluator positions himself inside or outside the carrier where he can best observe the action of the candidate. The evaluator's position should not interfere with the action of the candidate.

(2) The trial is complete when the candidate announces, "Up."

d. **Scoring.** Scoring procedures are as follows:

- (1) The candidate receives no credit when the--
 - Time exceeds 1 minute, 30 seconds (4.2-inch only); time exceeds 1 minute, 15 seconds (120-mm only).
 - Sight is not set at 3200 mils deflection and 900 mils elevation for the 4.2-inch only; sight is not set at 3200 mils deflection and 1100 mils elevation for the 120-mm only.

- Elevation and cross-level bubbles are not centered (within outer red marks).
- Turntable and traversing assembly slide are not centered. (For the 120-mm, the traverse extension must also be centered and locked.)
- Mortar standard assembly support is not in the firing position (raised) (4.2-inch only).
- The traversing lock handle is not locked.
- The detent pins are not in the innermost detent (4.2-inch only).
- The standard base trunnions are not correctly seated and aligned in the standard support trunnion bearing (4.2-inch only).
- The elevation locking cam is not locked (4.2-inch only).
- The recoil stop clamp is not in position and the wing nut is not taut (4.2-inch only).
- The white line on the barrel is not aligned with the white line on the buffer housing assembly (120-mm only).
- The mortar locking pin is not fully seated and locked (4.2-inch only).
- The mortar carrier rear hatch covers are not securely latched.
- The safety mechanism is not set on FIRE (F showing) (120-mm only).
- The cross-level locking knob is not hand tight (120-mm only).
- The buffer housing assembly is not positioned against the lower collar stop (120-mm only).
- The blast attenuator device knob is not hand tight (120-mm only).
- The assistant manipulates the sight and or mortar for elevation and or deflection (120-mm only).

(2) When the mortar is found to be in the correct firing position within the prescribed limits, credit is given as follows:

TIME		POINT CREDIT FOR EACH TRIAL
(seconds)		
120-mm	4.2-inch Mortar	
50 or less	65 or less	10
51 to 57	66 to 70	9
58 to 63	71 to 75	8
64 to 69	76 to 80	7

70 to 75	81 to 85	6
	86 to 90	5
76 or over	91 and over	0

9-23. SMALL DEFLECTION CHANGE

The candidate is tested at station No. 2 on his ability to perform the gunner's duties when he is given commands that require a change in deflection.

a. **Equipment.** Prescribed in Table 9-2.

b. **Conditions.** The mortar is prepared for action with sight installed.

(1) The sight is laid on two aiming posts (placed out 50 to 100 meters from the mortar) on a referred deflection of 2800 and 900 mils elevation (for the 120-mm, referred deflection of 2800 and 1100 mils elevation). The turntable is centered, and the traversing mechanism is within two turns of center of traverse. For the 120-mm, the turntable is centered, the traversing mechanism is within four turns of center of traverse, and the traverse extension is centered and locked. The vertical line of the sight is on the left edge of both aiming posts.

(2) The change in deflection causes the candidate to traverse the mortar at least 50 but not more than 75 mils. For the 120-mm, traverse the mortar 20 to 60 for deflection and 30 to 90 for elevation.

(3) The candidate selects an assistant gunner (4.2-inch only).

(4) The candidate is allowed to begin the test with his hand on the deflection knob.

c. **Procedure.** The candidate is given two trials; his credit score for the test is the total of these two trials.

(1) The evaluator announces an initial command requiring a change in deflection.

(2) The candidate repeats each element of the command, sets the sight with the data given, and traverses and cross-levels the mortar until he obtains the correct sight picture.

(3) Time is charged against the candidate from the announcement of the last digit of the elevation element until the candidate's announcement of "Up."

(4) For the 120-mm, deflection of 20 to 60 mils and elevation 30 to 90 mils.

(5) For the 120-mm, traverse extension will not be used.

d. **Scoring.** Scoring procedures are as follows:

(1) The candidate receives no credit when--

- The time exceeds 20 seconds (35 seconds for the 120-mm).
- The deflection is not indexed correctly (deflection and elevation are not set correctly for the 120-mm).
- The elevation and cross-level bubbles are not centered within the outer lines.
- The vertical cross line of the sight is not within 2 mils of the left edge of the aiming post.
- The traverse extension is centered and locked in position (120-mm only).

(2) When the mortar is laid correctly within the prescribed limits, credit is given as follows:

TIME (seconds)		POINT CREDIT FOR EACH TRIAL
120-mm	4.2-inch Mortar	
20 or less	10 or less	10
21 to 23	11 and 12	9
24 to 26	13 and 14	8
27 to 31	15 and 16	7
32 to 35	17 and 18	6
	19 and 20	5

9-24. REFERRING OF THE SIGHT AND REALIGNMENT OF AIMING POSTS

The candidate is tested at Station No. 3 on his ability to perform the gunner's duties in referring the sight and realigning the aiming posts.

a. **Equipment.** Prescribed in Table 9-2.

b. **Conditions.** The sight is laid on two aiming posts (placed out 50 and 100 meters from the mortar) on a referred deflection of 2800 mils and 900 mils elevation for the 4.2-inch mortar (1100 mils elevation for the 120-mm). The ramp is down with ammunition bearer in or outside the vehicle.

(1) The mortar is within two turns of center of traverse (four turns for the 120-mm). The candidate receives an administrative command with a deflection of 2860 or 2740 mils. The mortar is then re-laid on the aiming posts using the traversing crank.

(2) The candidate checks the conditions before each trial. He is allowed to start the test with his hand on the deflection knob of the sight.

(3) The change in deflection in the command must be less than 25 mils but greater than 5 mils. The elevation remains constant at 900 mils (1100 mils for the 120-mm).

(4) The candidate selects two assistants--one assistant realigns the aiming posts and the other assists in moving the turntable and cross-leveling. The assistants do not manipulate the sight or mortar for elevation or deflection.

(5) The traversing extension will not be used. It will remain locked in the center position.

c. **Procedure.** The candidate is given two trials; his credit score is the total of these two trials.

(1) A different command is given for each trial. The evaluator records the time and checks the candidate's work after each command has been executed.

(2) When the candidate is ready, he is given a command--for example, REFER, DEFLECTION TWO EIGHT EIGHT ZERO (2880), REALIGN AIMING POSTS.

(3) The candidate repeats each element of the command, sets the sight with the data given in the command, and directs one assistant in realigning the aiming posts. Upon completion of these actions, the candidate centers the traversing assembly and, with the help of the other assistant, moves the turntable and re-lays on the aiming posts. After he lays the mortar on the realigned aiming posts, he announces, "Up."

(4) Time is taken from the announcement of REFER, DEFLECTION TWO EIGHT EIGHT ZERO (2880), REALIGN AIMING POSTS until the candidate announces, "Up."

(5) The candidate's assistants are not permitted to leave the carrier until the command REALIGN AIMING POSTS is given.

d. **Scoring.** Scoring procedures are as follows:

(1) The candidate receives no credit when the--

- Time exceeds 1 minute, 40 seconds for the 4.2-inch; time exceeds 1 minute, 15 seconds for the 120-mm.
- Traversing assembly slide is turned before the aiming posts are realigned.
- Traverse extension and turntable are not locked in the center position (120-mm).
- Sight is set incorrectly for deflection or elevation.
- Elevation and deflection bubbles are not centered.
- Sight picture is not correct.
- Traversing assembly slide is more than two turns (four turns for the 120-mm) to the left or right of the center position.
- Assistant manipulates the sight or mortar for elevation or deflection.

(2) When the mortar is laid correctly within the prescribed limits, credit is given as follows:

TIME (seconds)		POINT CREDIT FOR EACH TRIAL
120-mm	4.2-inch Mortar	
60 or less	75 or less	10
61 to 65	76 to 80	9

66 to 70	81 to 85	8
71 to 75	86 to 90	7
76 to 80	91 to 95	6
	96 to 100	5
81 or over	21 or over	0

Note: If for any reason either of the aiming posts fall before the candidate announces, "Up," the trial will be terminated and re-administered.

9-25. LARGE DEFLECTION AND ELEVATION CHANGES

The candidate is tested at station No. 4 on his ability to perform the gunner's duties when he is given commands requiring a large change in deflection and elevation.

a. **Equipment.** Prescribed in Table 9-2.

b. **Conditions.** The evaluator selects a deflection change that is at least 200 but not more than 300 mils off the referred deflection of 2800 mils and 1100 mils elevation.

(1) The change in deflection involves movement of the turntable. The change in elevation causes the candidate to elevate or depress the barrel from low range to high range, or vice versa. The change in elevation is not less than 100 mils and not more than 200 mils for the 120-mm mortar.

(2) The candidate selects two assistants.

(3) Traversing extension and turntable are locked the center position.

(4) The candidate is allowed to check the deflection and elevation settings before each trial.

(5) The candidate is allowed to begin the test with his hand on the deflection knob.

c. **Procedure.** The candidate is given three trials. If he chooses to use the first (practice) as record, he must use the second as record. If he chooses to use the first trial as practice, he must use the second and third trials as record. He selects two assistants--one assistant may visually align the mortar, while the other elevates or depresses the standard assembly and assists in moving the turntable. The assistant does not manipulate the sight or lay the mortar for deflection.

- (1) The evaluator announces a command that requires a change in deflection involving movement of the turntable and an elevation change involving movement of the elevating mechanism cam.
- (2) The candidate is allowed to start the test with his hand on the deflection knob. He repeats each element of the fire command and sets the sight with the data given in the command.
- (3) As soon as the deflection element is announced, he can immediately place the data on the sight. The assistants must remain in their normal positions until the elevation element is given.
- (4) The evaluator times the candidate from the announcement of the last digit of the elevation command to the candidate's announcement of "Up."
- (5) A different deflection and elevation are given in the second trial.

d. Scoring. Scoring procedures are as follows:

- (1) The candidate receives no credit when the--
 - Time exceeds 60 seconds (55 seconds for the 120-mm).
 - Sight is not indexed correctly for deflection or elevation.
 - Elevation and cross-level bubbles are not centered.
 - Vertical line of the sight is more than 2 mils off the correct compensated sight picture.
 - Traversing mechanism is more than two turns (four turns for the 120-mm) off center of traverse.
 - Turntable is not in the locked position.
 - Assistants make any unauthorized manipulation of the mortar or sightunit for elevation or deflection.
 - Traversing extension is not locked in the center position.
- (2) When the mortar is laid correctly within the prescribed limits, credit is given as follows:

TIME (seconds)		POINT CREDIT FOR EACH TRIAL
120-mm	4.2-inch Mortar	
45 or less	35 or less	10

46 to 50	36 to 40	9
51 to 55	41 to 45	8
56 to 60	46 to 50	7
61 to 65	51 to 55	6
	56 to 60	5
66 or over	61 or over	0

9-26. RECIPROCAL LAYING

The candidate is tested at station No. 5 on his ability to quickly and accurately perform the gunner's duties in reciprocally laying the mortar.

a. **Equipment.** Prescribed in Table 9-2.

b. **Conditions.** The mortar is prepared for action and laid on an initial azimuth by the evaluator and his assistants.

- (1) The sight is set at 3200 mils deflection and 900 mils elevation.
- (2) The evaluator sets up the aiming circle about 75 meters from the carrier where it is visible to the gunner.
- (3) The evaluator orients the aiming circle on an azimuth of not less than 150 mils or not more than 200 mils away from the initial azimuth.
- (4) The candidate is allowed to begin the test with his hand on the deflection knob with the carrier engine running.
- (5) A relay man is positioned halfway between the aiming circle and carrier to relay commands.
- (6) The traversing mechanism is centered and the traversing extension is locked in the center position.

c. **Procedure.** The candidate is given three trials. If he chooses to use the first (practice) as record, then he must use the second as record. If he chooses to use the first trial as practice, then he must use the second and third trials as record.

- (1) The evaluator operates the aiming circle during the test.

- (2) Once the candidate identifies the aiming point, the evaluator announces the deflection.
- (3) Time is started from the last digit of the first deflection announced by the evaluator.
- (4) When the candidate announces, "Ready for recheck," the evaluator immediately announces the new deflection.
- (5) The trial is complete when the gunner announces, "Zero mils (or one mil), mortar laid."

d. Scoring. Scoring procedures are as follows:

- (1) The candidate receives no credit when the--
 - Time exceeds 2 minutes, 15 seconds for the 4.2-inch; time exceeds 1 minute, 33 seconds for the 120-mm.
 - Difference between the deflection setting on the sight and the last deflection reading from the aiming circle is more than 1 mil.
 - Elevation and cross-level bubbles are not centered.
 - Vertical reticle line of the sight is not centered on the lens of the aiming circle.
 - Traversing extension is not locked in the center position.
 - The mortar sight and the aiming circle are not sighted on each other with a difference of more than 1 mil between deflection readings.
 - Turntable is not centered and locked.

(2) When the mortar is laid correctly, credit is given as follows:

TIME (seconds)		POINT CREDIT FOR EACH TRIAL
120-mm	4.2-inch Mortar	
55 or less	60 or less	10
56 to 67	61 to 75	9
68 to 79	76 to 90	8
80 to 90	91 to 105	7

91 to 95	106 to 120	6
	121 to 135	5
96 or over	136 or over	0

9-27. SUPPORT SQUAD

Support squads are located in cavalry units, task units, and light infantry units. The gunner's examination for the support squad is the same as that used by the mortar section, except for the reciprocal laying, and refer and realign stations. The tests below are substituted respectively for the reciprocal laying and for the refer and realign stations. The entire refer and realign station is eliminated, and the procedures for direct lay are used.

a. **Reciprocal Laying.** In this test (4.2-inch mortar only) the compass is substituted for the aiming circle.

(1) *Conditions.* The mortar is prepared for action and laid on an initial azimuth by the evaluator and his assistants.

(a) The turntable is centered with the sight set at 3200 mils deflection and 900 mils elevation.

(b) The evaluator places the M2 compass on a stake about 75 meters from the mortar carrier and measures the azimuth to the mortar sight. He then selects a mounting azimuth from the azimuth measured to the mortar sight.

(c) The candidate selects an assistant gunner and driver.

(d) The evaluator ensures that the candidate understands the requirements of the test and instructs him to report I AM READY before each trial.

(2) *Procedure.* The candidate is given two trials; his credit score for the test is the total of these two trials.

(a) The evaluator operates the compass during the test.

(b) When the candidate identifies the aiming point, the evaluator announces the deflection.

(c) When the gunner is laid back on the aiming point, he announces, "Up," and the evaluator commands REFER,

DEFLECTION TWO EIGHT ZERO ZERO (2800), PLACE OUT AIMING POSTS.

(d) The ammunition bearer moves out as soon as the initial deflection has been announced by the evaluator and places out the aiming posts as directed by the gunner.

(e) The trial is complete when the gunner announces, "Up," after the aiming posts are in position.

(3) *Scoring.* The scoring procedures are as follows:

(a) The candidate receives no credit when the--

- Time exceeds 2 minutes, 15 seconds.
- Deflection placed on the sight is incorrect.
- Elevation and cross-level bubbles of the sight are not centered.
- Turntable is not centered.
- Aiming posts are not properly aligned.

(b) When the mortar is laid correctly, credit is given as follows:

TIME (seconds)	POINT CREDIT FOR EACH TRIAL
70 or less	10
71 to 81	9
82 to 92	8
93 to 103	7
104 to 114	6
115 to 125	5
126 or over	0

b. Reciprocal Laying (Light Infantry Mortars). In this test, the sight-to-sight method is used to reciprocal lay the mortar.

(1) *Conditions.* The mortar is prepared for action on an azimuth by the evaluator and his assistants.

- (a) The sight is set at 3200 mils deflection and 1100 mils elevation.
- (b) The evaluator sets up the base mortar about 35 meters from the test mortars where it is visible to the gunner.
- (c) The evaluator orients the base mortar on an azimuth of not less than 150 mils or more than 200 mils away from the initial azimuth.
- (d) The candidate selects an assistant gunner (optional for the 60-mm mortar).
- (e) The candidate is allowed to begin the test with his hand on the deflection micrometer knob.
- (f) The evaluator ensures that the candidate understands the requirements of the test, and he instructs him to report I AM READY before each trial.

(2) *Procedure.* The candidate is given two trials; his credit score is the total of these two trials.

- (a) The evaluator positions himself at the base mortar and commands AIMING POINT THIS INSTRUMENT.
- (b) The gunner refers his sight to the aiming point and replies, "Aiming point identified."
- (c) The evaluator reads the deflection from the sight of the base mortar. He determines the back azimuth of that deflection by adding/subtracting 3200 mils and announces the deflection--for example, the deflection on the base mortar is 1200 mils. The evaluator adds 3200 mils to this deflection ($1200 + 3200 = 4400$ mils) and announces, "Number one, deflection four four zero zero (4400)."
- (d) The candidate repeats the announced deflection, sets it on the sight, and, with the help of his assistant gunner, lays the mortar on the center of the base mortar sight lens. He then announces, "Number one ready for recheck." The evaluator announces the new deflection as soon as possible so that there is no delay.
- (e) The operation is completed when the candidate announces, "Number one, zero (or one) mil(s), mortar laid."

(3) *Scoring.* The scoring procedures are as follows:

(a) The candidate receives no credit when the--

- Time exceeds 1 minute, 55 seconds.
- Deflection placed on the sight is incorrect.
- Elevation and cross-level bubbles of the sight are not centered.
- Mortar is not within two turns of center of traverse (four turns for the 120-mm).
- The sight and the base mortar sight are not sighted on each other with a difference of not more than 1 mil between deflection readings.

(b) When the mortar is laid correctly, credit is given as follows:

TIME (seconds)	POINT CREDIT FOR EACH TRIAL
55 or less	10
56 to 67	9
68 to 79	8
80 to 91	7
92 to 103	6
104 to 115	5
116 or over	0

APPENDIX A

TRAINING DEVICES

The most efficient and direct method of teaching conduct of fire is by firing combat ammunition under field conditions. However, ammunition training allowances and range limitations often restrict such training to subcaliber firing on reduced or miniature ranges.

Section I. THE 60-mm SUBCALIBER ASSEMBLY

The 60-mm subcaliber assembly is a training device for use with the 4.2-inch mortar system.

A-1. DESCRIPTION

The subcaliber assembly consists of a 60-mm barrel modified for inserting into a 4.2-inch barrel. The M2 60-mm barrel is the only barrel authorized for use. The components of the assembly are an insert, filler block, and filler block retriever.

- a. The insert (Figure A-1) consists of a 60-mm mortar barrel, which is fitted with two aluminum rings that allow it to fit snugly into the 4.2-inch barrel. The aluminum rings also prevent the rifling in the barrel from being scored (Figure A-2).

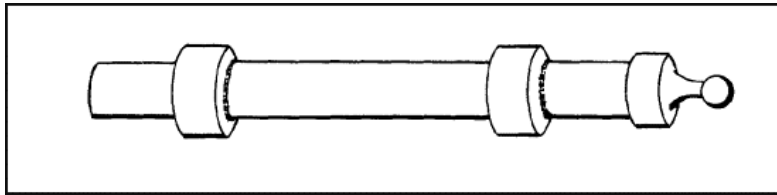

Figure A-1. The 60-mm mortar insert.

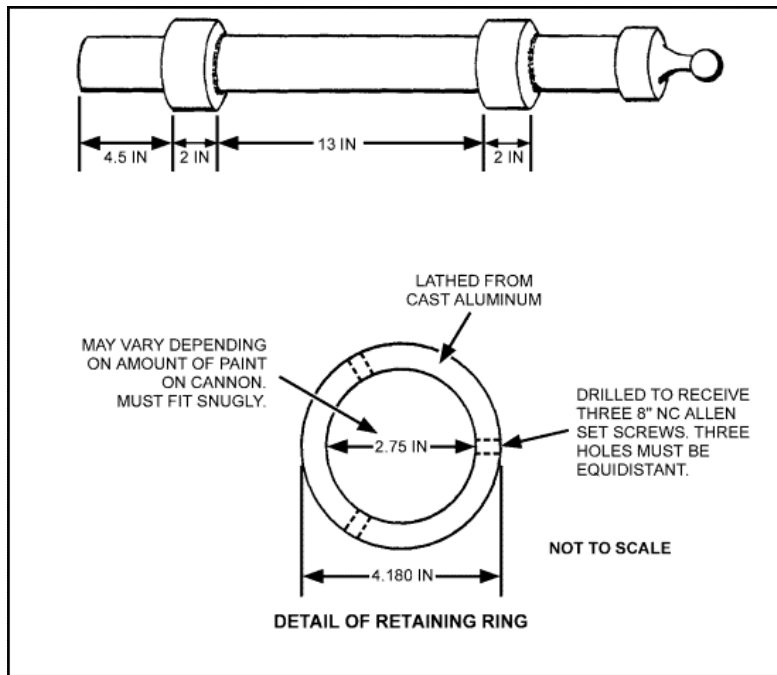

Figure A-2. Aluminum rings.

b. The filler block (Figure A-3) consists of a round steel pipe fitted with an aluminum shock cap on either end, which fit snugly into the barrel without scoring it. Either aluminum cap receives the spherical projection of the 60-mm barrel and distributes the recoil shock. The center of each cap is threaded to receive the filler block retriever. The shock caps fit over the striker pin of the 4.2-inch barrel, allowing all the shock to be exerted on the base end of the barrel rather than on the striker pin (Figure A-4).

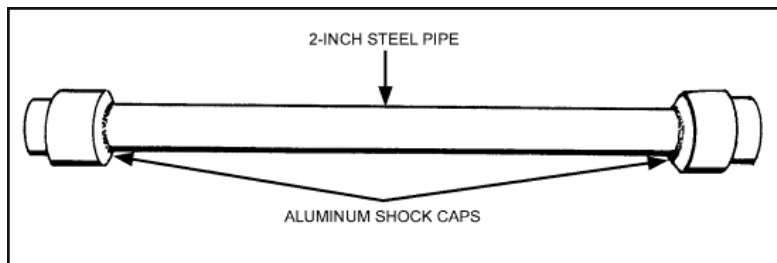

Figure A-3. Filler block.

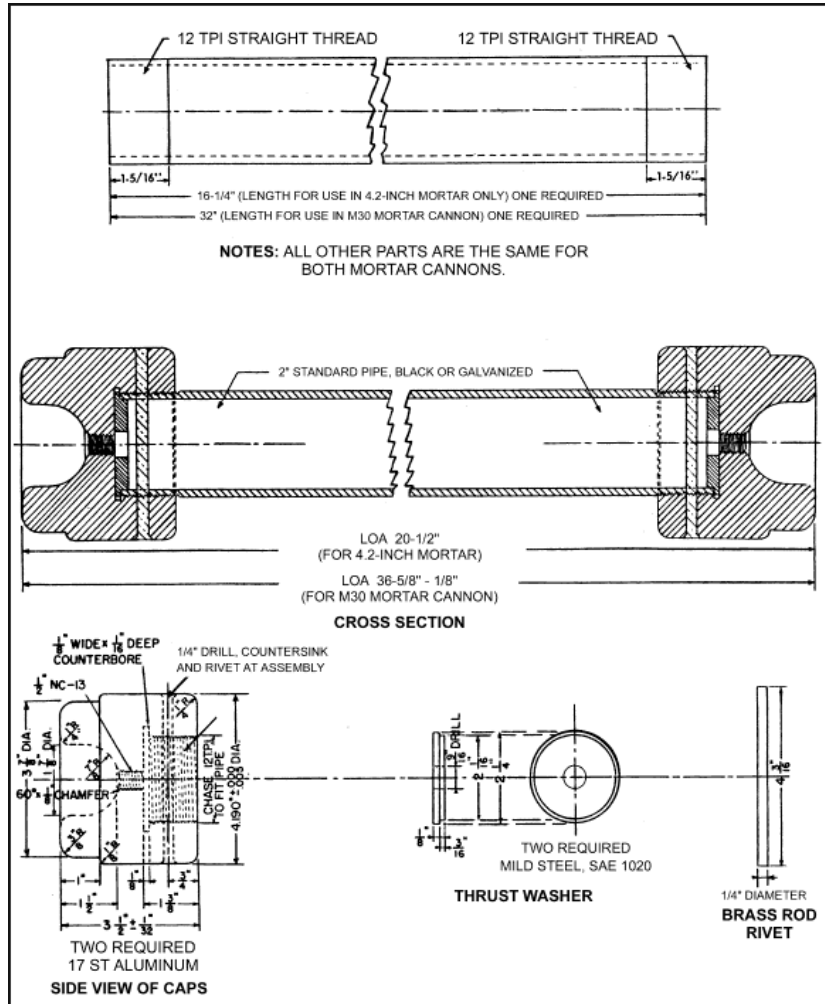

Figure A-4. Construction details of the filler block.

c. The filler block retriever (Figure A-5) is used to remove the filler block from the 4.2-inch mortar. It is a steel rod fitted with a handle on one end. The other end

is threaded so that it can be screwed into the shock cap of the filler block (Figure A-6).

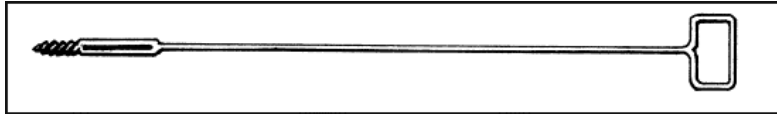

Figure A-5. Filler block retriever.

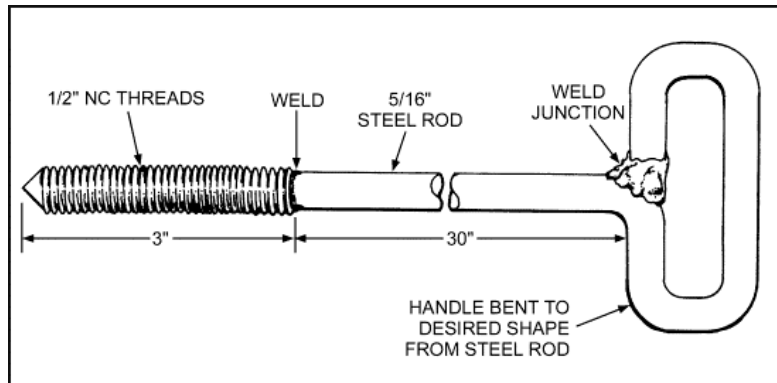

Figure A-6. Construction detail of the filler block retriever.

Note: The subcaliber mortar kit is obtained from the supporting ordnance unit. See TM 9-1015-215-23&P for more information.

A-2. ASSEMBLY

The subcaliber assembly does not affect the use of the sight, traversing assembly slide, or elevation mechanism of the 4.2-inch mortar. To install the subcaliber assembly, the mortar is mounted, and then the filler block is slid down the barrel. The insert (60-mm barrel with rings) is slid down the barrel, protruding about 1 1/2 inches.

A-3. DISASSEMBLY

To disassemble the subcaliber assembly, the protruding barrel of the 60-mm mortar is grasped and lifted out of the 4.2-inch barrel. The retriever is screwed into the filler block and lifted out of the block.

A-4. AMMUNITION

All types of 60-mm mortar ammunition that are listed in FT 60-Q-1, including training, practice, and HE rounds, can be fired from the subcaliber assembly. The 60-mm mortar training round is usually fired on a training range; the practice round and HE round are used on a standard field firing range. When an ammunition shortage prevents field fire training with 4.2-inch rounds, 60-mm practice or HE ammunition can substituted.

a. **High-Explosive Round, M49-Series.** This round is the standard B ammunition for the M224 60-mm mortar.

(1) The M49A2 HE round is painted olive drab. It consists of a hollow body (Figure A-7), fin assembly that screws on the rear of the body, and M525 fuze that is attached to the front of the round. A TNT bursting charge is contained in the body and is ignited by the booster charge in the fuze upon impact. The fin assembly contains the ignition cartridge and provides a means for attaching the propelling increments. The fins keep the projectiles stable in flight. This round weighs 3 pounds, and it can be fired at a maximum range of about 1,800 meters. Each round comes in a separate fiber container complete for firing.

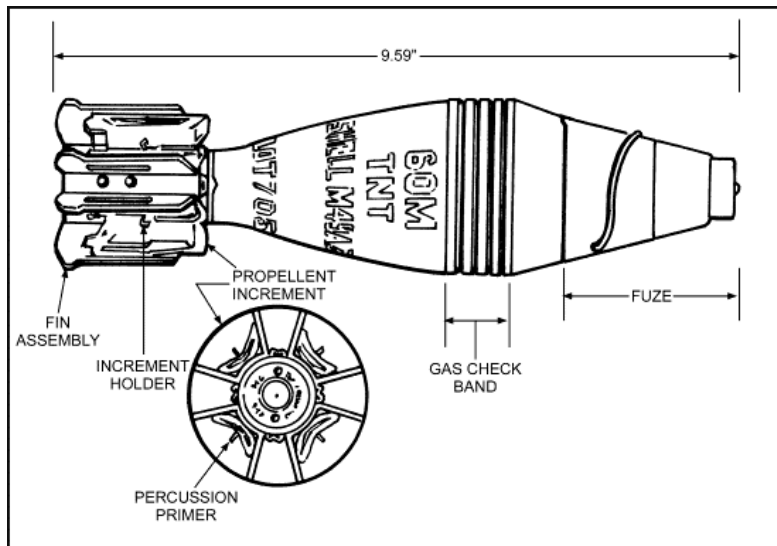

Figure A-7. HE round, M49A2.

Note: For more information see TM 9-1300-203 and FT 60-L-5.

(2) Before firing, the fuze must be checked. The safety wire is removed, and the round is held vertically while pressing the bore riding safety pin inward to check tension. If the pin becomes unseated, the round is considered unsafe and should not be fired. **ANY ROUND THAT IS ISSUED WITHOUT A BORE RIDING SAFETY PIN SHOULD NOT BE FIRED.**

b. **Practice Round, M50A2.** This round is designed to give mortar crews practice in firing and technique of fire without the expense incident to firing HE ammunition. On impact, the practice round emits a puff of white smoke that is clearly visible to the observer. This round differs from the HE round described above in color and filler only. It is painted blue.

Note: The firing table for this round is FT 60-L-5.

A-5. CARE AND CLEANING

The care and cleaning procedure described in TM 9-1015-215-10 applies to the subcaliber assembly.

A-6. SAFETY

The safety precautions for 4.2-inch ammunition must be observed along with the following safety rules:

a. **During Firing.** Personnel never move forward of the OP area nor do they pound an ignition cartridge into the fin assembly since the primer could detonate.

b. **Misfire Procedure.** The procedure before actual removal of the round is the same as that used with service ammunition.

(1) To remove the round, the assistant gunner gently removes the 60-mm barrel from the 4.2-inch barrel by grasping the 60-mm barrel around the muzzle with both hands and lifting (Figure A-8), ensuring that no part of his hands protrudes over the muzzle. The gunner guides the 60-mm barrel with his thumbs. When the base aluminum ring of the 60-mm barrel reaches the end of the 4.2-inch barrel, the gunner firmly grasps the base aluminum ring to prevent it from dropping and jarring the barrel. The gunner grasps the base end of the 60-mm barrel and lifts it to the horizontal. **HE DOES NOT STAND BEHIND IT.**

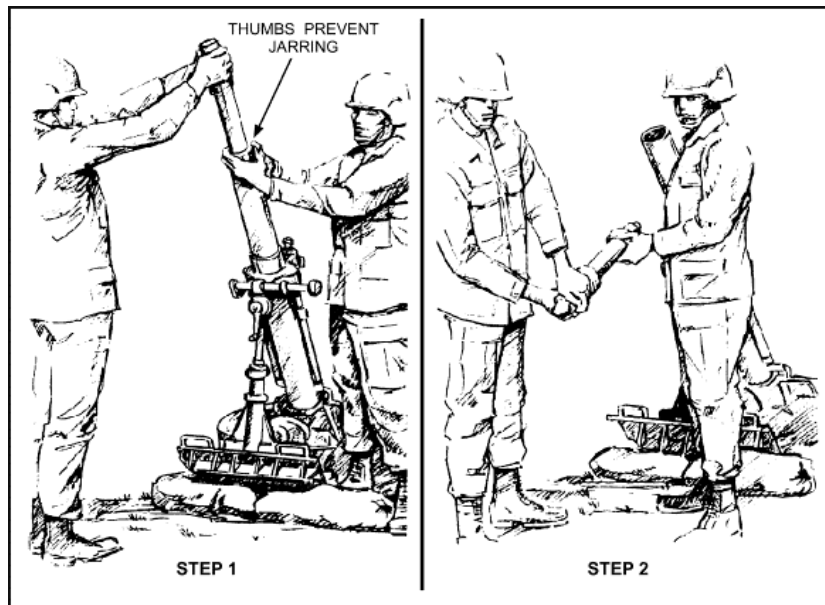

Figure A-8. Misfire procedure (60-mm subcaliber device).

(2) The assistant gunner, hands still positioned around the 60-mm barrel, extends the thumbs of both hands over the edge of the muzzle. When the barrel reaches the horizontal, the gunner continues to lift the base end of the barrel until the round slides forward (Figure A-8). Once the barrel is horizontal, the base end is not lowered until the misfire has been removed.

(3) The assistant gunner's thumb stops the round when the round reaches the muzzle. He then removes it from the barrel and hands it to an ammunition bearer. The gunner shakes the 60-mm barrel to empty any foreign material from the bore and reinserts it into the 4.2-inch barrel. The assistant gunner swabs the bore.

A-7. RANGE CONSTRUCTION

The construction of a training round range is easily accomplished, requiring a minimum of space and effort. The range is measured in meters (Figure A-9) and consists of a target (impact) position area, OP position area, mortar position area, and FDC position area. A range 30.5 meters wide is adequate.

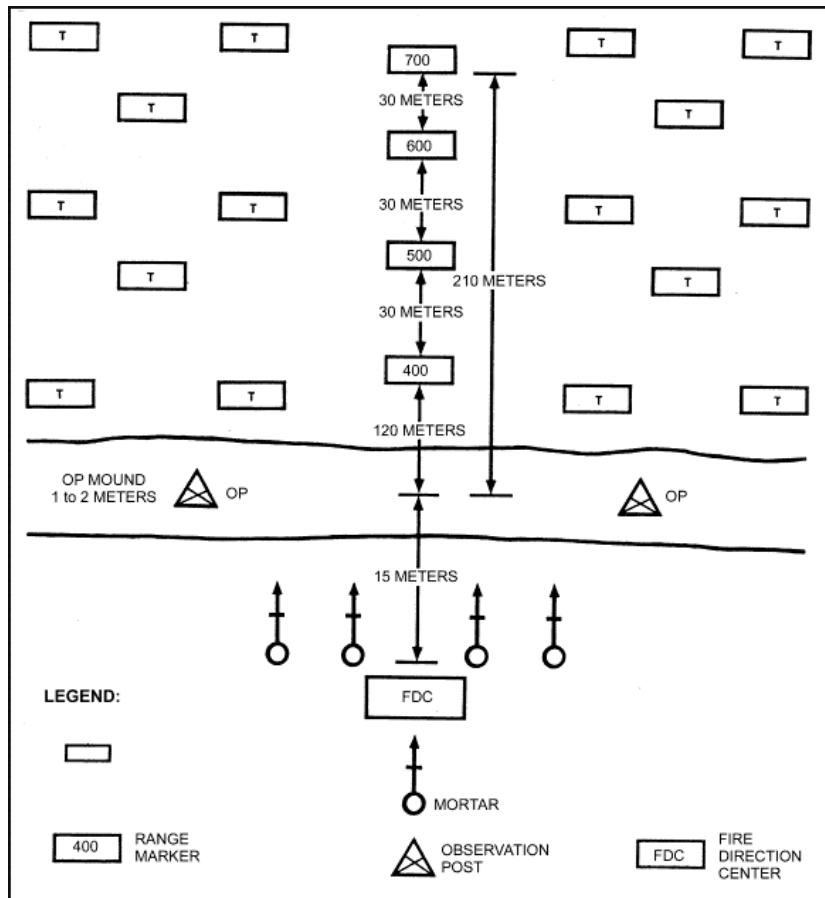

Figure A-9. Training range.

a. The target position area consists of range markers in hundreds of up to 700 meters with various targets staggered throughout. The range markers are placed at 30-meter intervals (each interval represents 100 meters on the ground), the first marker being 120 meters from the OP positions (marked 400). The markers are rectangular, 30.5 by 45.5 centimeters. Targets should be constructed to represent various objects such as trees and houses; however, barrels or boxes placed throughout the area are adequate. These targets and markers can be constructed from scrap lumber and can be made portable, which allows the target area to be

cleared for other purposes. When all practice targets look alike, they should be painted different colors to assist the FO.

b. The OP position area is between the firing position and target area. It should afford full observation of the target area; normally, a mound should suffice. When the range is in use, telephone communication is established between the OP and FDC.

c. The mortar position area is 15 meters to the rear and off-line from the OP position; mortars are mounted laterally 6 meters apart. A mask should exist between the target area and firing position. If it does not, a target cloth screen might need to be placed between the target area and firing position.

d. The FDC is established close enough to the mortar position to permit voice communication between the two. Wire or radio communication is established between the FDC and OP.

A-8. OPERATION

Mortarmen are assembled at the OP for an orientation on range organization.

a. Mortarmen are assigned as FDC members, as crew members at the mortar position, and as FOs, and periodically rotate assignments during training. Training is conducted in the following sequence:

- (1) The OP sends a fire request to the FDC to begin a registration point adjustment.
- (2) The FDC computes a fire command and sends it to the mortars.
- (3) The mortar crew members lay the mortars and fire.
- (4) Adjustment is continued until the registration point has been established.
- (5) The FDC then directs the OP to adjust the sheaf when ready.
- (6) The section is then given a command of referred deflection.
- (7) From this point on, various targets can be engaged using different types of adjustment.

b. As the range is laid out in meters, all corrections and computations are in meters; however, the mil-relation formula applies. To obtain the best results, the FDC allows each square on the target grid or M16 plotting board to equal 25 meters.

Section II. SABOT, M1

This section provides the technical information required to employ the sabot. However, trainers should exercise imagination and ingenuity in developing training situations for employing the system.

A-9. DESCRIPTION

The 81-mm sabot (inert), M1, assist crews in reaching technical and tactical proficiency, thus, strengthening their ability to be effective on the modern battlefield. With the 22-mm subcaliber practice cartridge, the sabot (M1) provides an economical means of training personnel in all phases of mortar gunnery. These devices consist of two major components: the 81-mm sabot and 22-mm subcaliber cartridge (Figure A-10).

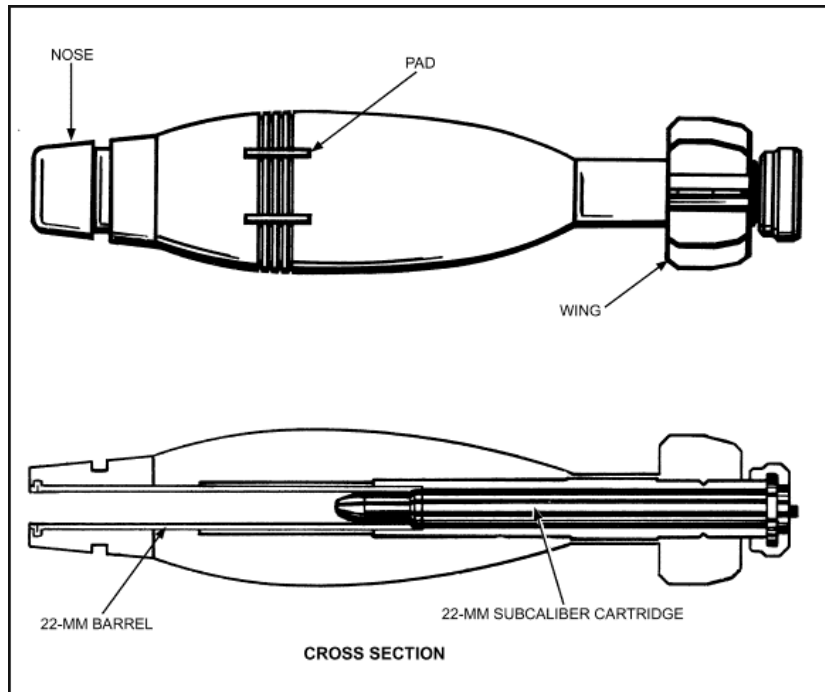

Figure A-10. Sabot, M1, and cross section.

- a. The sabot is designed to fire the subcaliber cartridge (Figure A-11) through the barrel. The subcaliber cartridge, when loaded into the sabot, approximates a round of service ammunition both in size and weight. The entire assembly is then fired

from the mortar just as in service firing. The subcaliber projectile travels from 70 to 435 meters, depending on the charge and elevation selected. The projectile emits a puff of smoke and an audible report upon impact, but no fragmentation. At the time of firing, the sabot is also expelled from the mortar and impacts 2 to 15 meters from the mortar (Figure A-12, D). It is then recovered, cleaned, and reloaded.

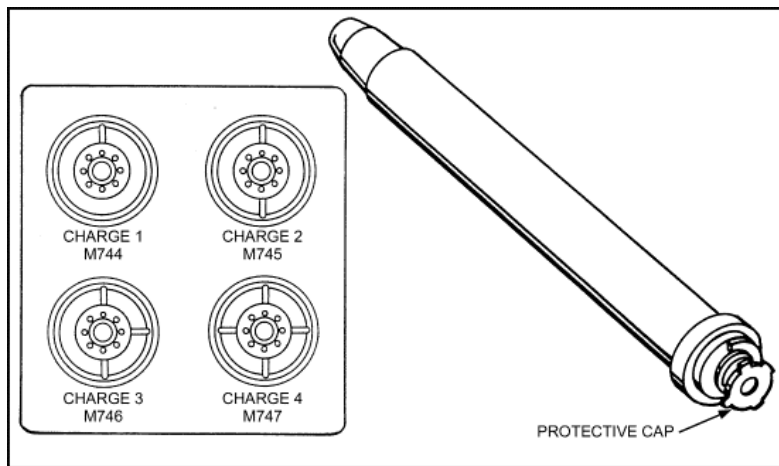

Figure A-11. Subcaliber cartridge. Figure 1.

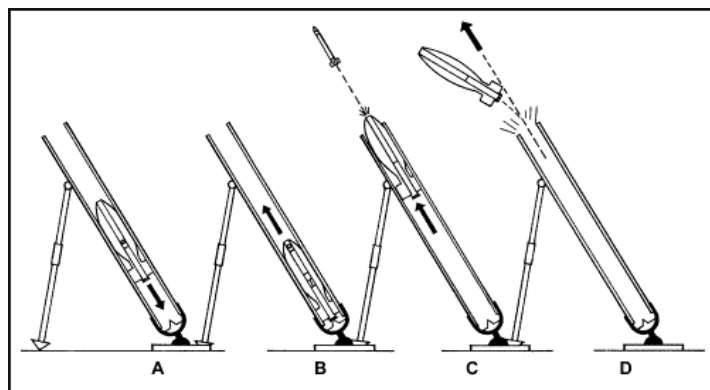

Figure A-12. Firing of mortar training device and cartridge.

b. A scale ratio of 1:10 is used to relate the range and deviation between the subcaliber projectile and standard 81-mm service projectile. Thus, the minimum range requirement for firing through charge 4 is an area 500 meters deep, and wide enough to accommodate the desired number of targets plus a 45-meter safety zone on each side of the flank targets (Figure A-13).

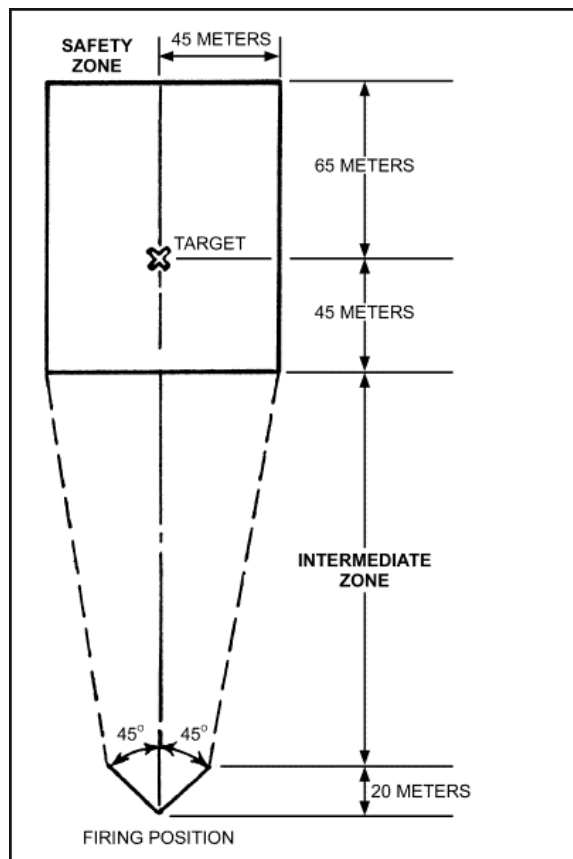

Figure A-13. Minimum range area.

A-10. ADVANTAGES

The advantages of using the 81-mm sabot are:

- Provides the capability for firing in training areas where the firing of conventional mortar ammunition is prohibited.
- Saves time and expenses of long-distance traveling to suitable mortar ranges.
- Saves the expense of firing service ammunition.
- Simplifies operation, maintenance, and training.
- Follows identical mortar crew procedures as service firing, excluding appropriate charge and fuze settings.
- Uses the same equipment required for service firing.

Mortar units using the 81-mm mortar sabot require little training in preparation to use the device. The sabot is used with all standard 81-mm mortar equipment regardless of model. It accommodates prescribed squad drill procedures and can be used by mechanized and ground-mounted mortar sections and squads.

Note: Refer to TM 9-1315-249-12&P for detailed information.

A-11. DISADVANTAGES

The disadvantages of using the 81-mm sabot are:

- Causes excess carbon buildup in the barrel due to subcaliber ignition.
- Increases deterioration of the barrel.

A-12. EQUIPMENT

The following equipment is required to conduct training with the 81-mm sabot:

- All TOE mortar section/platoon equipment.
- Three 81-mm sabots for each mortar.
- Cleaning equipment.
- A piece of canvas or other heavy material, 3 meters by 15 meters, for placement in front of each mortar to catch the sabot when fired. This prevents damage to the sabot and reduces the cleaning time required during firing.
- If mortars cannot be mounted in defilade, a mask of target cloth, canvas, or other suitable material can be built between the mortars and impact area.

A-13. AMMUNITION

The ammunition used in the M1 and M3 sabots is described herein.

- a. **The 81-mm Sabot.** The aluminum alloy sabot has dimensions and a configuration similar to 81-mm service ammunition.

- (1) The sabot body contains a 22-mm smooth-bore barrel to receive the 22-mm subcaliber cartridge, which is loaded before firing. The boom of

the sabot has fins similar to the fins of the service ammunition, and the body has pads to guide the sabot as it travels out of the barrel. Upon firing, the loaded sabot is ejected from the barrel; the sabot lands on the ground within 15 meters of the mortar while the subcaliber projectile continues its flight to the impact area.

(2) When not loaded with a subcaliber cartridge, the sabot can be used as a dummy round for crew drill or the squad leader can "load" it with an expended cartridge case to induce a "misfire." The sabot can be reloaded and fired repeatedly for training. It is stored without the subcaliber cartridge in a packing box containing three sabot devices.

b. **The 22-mm Subcaliber Cartridge.** The 22-mm subcaliber cartridges (Figure A-14) are boxed and issued by charge: M744, charge one; M745, charge two; M746, charge three; M747, charge four. The charges can readily be identified day or night by the number of slots in the base of the subcaliber cartridge case (Figure A-15).

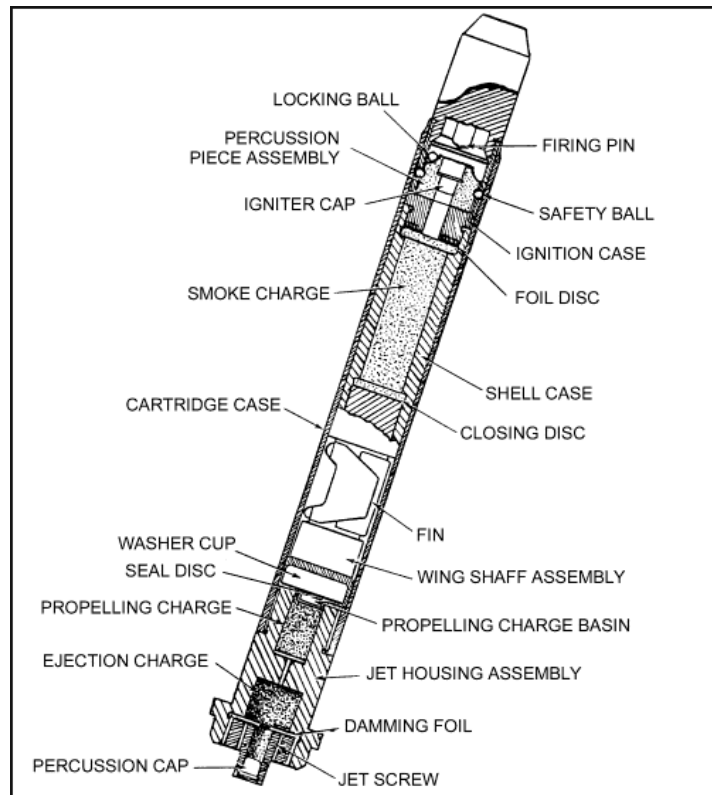

Figure A-14. The 22-mm subcaliber cartridge cross-section.

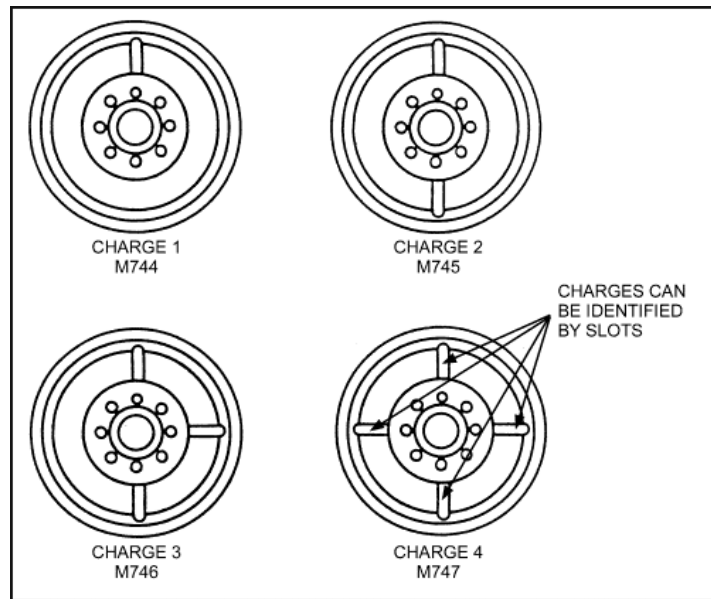

Figure A-15. Base of subcaliber cartridges--charge one through four.

(1) The 22-mm cartridge consists of the projectile with stabilizer fins and cartridge case. The projectile body contains the impact fuze and a smoke signal charge. The propelling and ejection charges are contained in two separate chambers located in an assembly threaded onto the base of the cartridge case. A flash hole between the chambers permits ignition of the propelling charge by the ejection charge.

(2) When the 22-mm subcaliber cartridge is inserted into the sabot, the sabot is ready for firing. The protective plastic cap covering the percussion cap of the subcaliber cartridge is removed before dropping the sabot into the mortar barrel. When fired, the cartridge's percussion cap strikes the firing pin and is ignited. The percussion cap ignites an ejection charge in the jet housing assembly. The propelling gases emerge through the eight holes in the jet screw assembly and initiate travel of the sabot and subcaliber cartridge up the mortar barrel. At the same time, the ejection charge ignites the subcaliber projectile propelling charge contained in the jet housing assembly. This propels the subcaliber projectile out of the cartridge case and through the 22-mm barrel of the sabot. When the sabot clears the muzzle, the subcaliber projectile clears the barrel. The sabot impacts on the ground within 15 meters of the mortar while the subcaliber projectile continues its trajectory.

(3) After the subcaliber projectile has left the sabot barrel, the impact fuze is activated. The percussion assembly, which contains the primer for the fuzing mechanism, is held in position within the ignition case by two safety balls. When the projectile clears the sabot barrel, the safety balls move outward, freeing the percussion piece. The stabilizing fins open as the projectile clears the sabot barrel, providing in-flight stability. When the projectile ascends to its maximum ordinate, a locking ball keeps the percussion piece from moving forward, preventing the cap from contacting the pin. This feature precludes premature functioning should the projectile strike a tree branch or other object (Figure A-16).

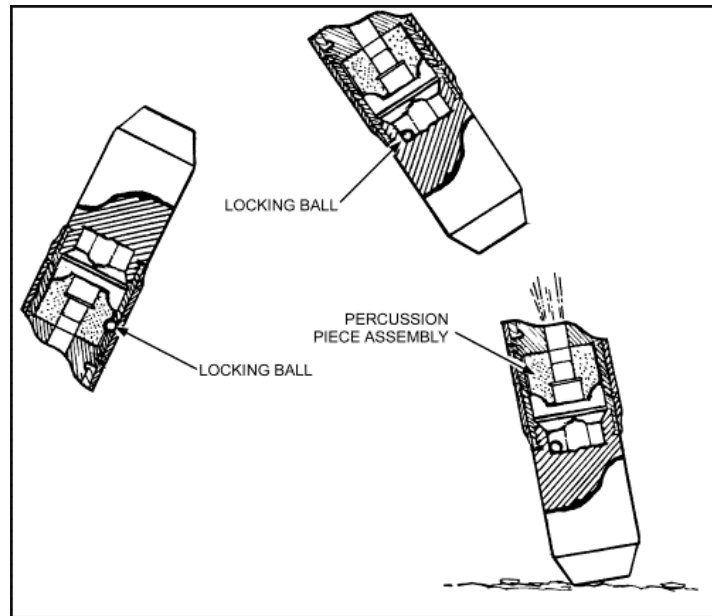

Figure A-16. Safety device.

(a) As the projectile descends from the high point of its trajectory, the locking ball falls into an empty space in the projectile head and the fuzing mechanism is fully armed.

(b) At the moment of impact, the percussion piece moves forward, allowing the igniter cap to strike the firing pin. The igniter cap initiates the smoke charge, and gas pressure produced by the burning smoke charge ejects the wing assembly from the base of the case. The smoke charge produces a yellow cloud of smoke.

The initial release of the smoke by the wing shaft assembly produces a sound (Figure A-17).

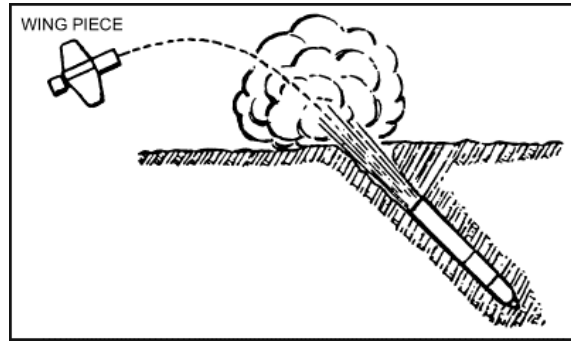

Figure A-17. Optical and acoustical observation of target strikes.

(4) To prepare for firing, the bore and chamber of the sabot are inspected for cleanliness. The flange nut is removed from the sabot by unscrewing counterclockwise. The 22-mm cartridge is inserted into the chamber of sabot, and the flange nut is screwed onto the sabot hand tight. The plastic protector cap is removed from the percussion cap. The ground in front of the mortar should be covered with canvas or a heavy plastic or vinyl-type material to protect the sabot from dirt or mud. The flange nut is removed, the expended cartridge case is extracted, and the sabot is cleaned. The sabot is reloaded with a new subcaliber cartridge, and it is ready to be fired again.

WARNING

Personnel must not stand in front or to the rear of the sabot when inserting the cartridge.

A-14. SAFETY

Sabot training devices are safe to handle and fire. The following safety precautions must be enforced.

WARNING

The 81-mm sabot is inert and can be stored and handled as a

at which time it will be handled as a live mortar round. The sabot can function as a cannon and should be secured in the same manner as any other weapon. When loaded and ready to fire, all safety precautions used during handling of service ammunition are observed.

a. The 22-mm subcaliber cartridge contains propellant and smoke charge, and is always stored and handled as live ammunition.

Note: The general safety precautions for fixed ammunition are located in TM 9-1300-206 and AR 385-63.

b. Practice ammunition is never fired over heads of troops.

c. Personnel never enter the danger area during the firing of the practice ammunition.

Note: Duds are disposed of as prescribed in TM 9-1315-249-12&P.

A-15. MALFUNCTIONS

See Chapter 3, paragraph 3-13 for a detailed discussion of malfunctions.

A-16. REMOVAL OF A MISFIRE

After failure to fire, misfire removal procedures are followed to remove the round from the weapon. If the primer cap of the 22-mm cartridge is dented, the cartridge is removed carefully from the sabot by unscrewing the flange nut, and then tagging the cartridge for disposal according to local SOP. If the primer is not dented, cause of failure to fire could be due to a malfunction of the mortar. Misfire procedures for live rounds also apply when firing the sabot. The only difference is in handling of the round after it has been removed from the mortar.

a. If the primer of the subcaliber cartridge is dented, the cartridge is carefully removed from the sabot, ensuring that the sabot is pointed downrange and that no one is to the front or rear. The subcaliber cartridge is removed to a designated area for disposal IAW local SOP.

b. If the primer is not dented, the round can be refired upon determination of the cause of the misfire.

A-17. ITEM DESCRIPTION AND SUPPLY DATA

The equipment shown in Table A-1 is available at the ammunition supply facility, except for an 81-mm sabot.

DESCRIPTION	NATIONAL STOCK NO.	PART NO.	DODAC NO.
Sabot, 81-mm Practice: M1 (Inert)	1015-00-328-5666	9287906	
Cartridge, Subcaliber, 22-mm Practice: Charge 1, M744	1305-00-334-5920	92787907	1305-A680
Cartridge, Subcaliber, 22-mm Practice: Charge 2, M745	1305-00-334-5922	9287908	1305-A681
Cartridge, Subcaliber, 22-mm Practice: Charge 3, M746	1305-00-334-5934	9287909	1305-A682
Cartridge, Subcaliber, 22-mm Practice: Charge 4, M747	1305-00-334-5935	9287910	1305-A683

Table A-1. Equipment description and supply data.

A-18. TRAINING

An advantage of sabot training is that the unit commander can observe the actions of all members of the indirect fire team while performing all the tasks that are employed during live firing. This enhances the ability of the commander to evaluate the proficiency of all elements of the team, to identify and isolate problem areas, and to begin corrective training. Also, all members of the team are able to view the entire operation and to understand how they fit into the overall plan.

a. **Preparation.** The amount of time spent preparing for training determines the benefits received from using the 81-mm sabot. Three steps must be accomplished before training with the 81-mm sabot:

- Construction of a scaled firing range (permanent, semi-permanent, and temporary).
- Construction of a map of the firing range.
- Instruction of personnel on the use of equipment.

- (1) Sometimes it is desirable for gunners to observe the impact of the sabot. However, mortars are usually mounted in a defilade position so that a mask exists between the impact area and the firing position. If such a mask does not exist, one can be constructed of target cloth or other suitable material. The mask must be removed when firing direct lay missions.
- (2) A heavy canvas or other suitable material should be placed on the ground to a distance of 15 meters in front of each mortar to catch the sabot. On a permanent sabot range, it is desirable to construct a permanent impact area for the sabot--a sawdust or sandpit covered with heavy canvas would be ideal.
- (3) When positioning the mortars, the lateral distance between the center of the baseplates should not exceed 4 meters. Special corrections can be applied to fire for effect if the weapons are more than 4 meters apart, but it is unrealistic to habitually apply special corrections during training.
- (4) When using the sabot with each of the weapons separated by 3.5 to 4 meters, some special techniques must be used. Aiming posts should be identified by squad to preclude a mix-up of aiming posts between two mortars. Numbers, colors, or any other easily discernible method can be used.
- (5) Problems can be encountered when traversing carrier-mounted mortars during large deflection changes of more than 300 mils left or right of direction of fire (Figure A-18). The carriers should be traversed to avoid the possibility of hitting adjacent carriers with the sabot. Due to the minimum range of the sabot, it must be fired only over the rear of the carrier with the ramp in the up position.

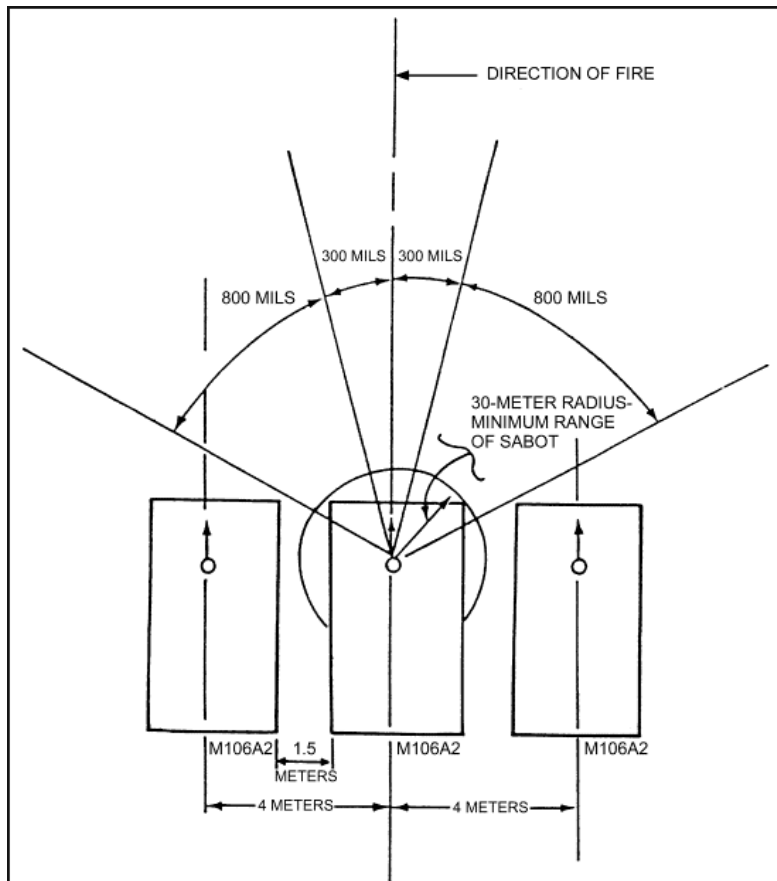

Figure A-18. Large deflection changes.

b. Section Procedures. When firing the sabot, organic fire control equipment, and traversing and elevating mechanisms are used to lay the mortars for direction and elevation. The crew consists of the gunner, assistant gunner, ammunition bearer, and driver.

- The gunner and assistant gunner perform their duties as though firing service ammunition.
- The ammunition bearer and driver perform their assigned duties.
- Personnel can be rotated for cross training.

(1) During the conduct of firing, realistic commands are announced to the section. For example, SECTION, NUMBER TWO, ONE ROUND, DEFLECTION TWO SEVEN EIGHT FIVE (2785), CHARGE THREE, ELEVATION ONE ZERO SIX SIX (1066). Each command requires the section to respond as though service ammunition were being fired. The ammunition bearer then:

- (a) Secures a sabot and selects the appropriate 22-mm subcaliber cartridge; in this case, charge 3 (three slots in the base of the cartridge case).
- (b) Removes the flange nut.
- (c) Ensures that the sabot is pointed downrange and no one is to the rear.
- (d) Loads the subcaliber cartridge into the sabot.
- (e) Replaces the flange nut.
- (f) Removes the plastic cap from the primer and passes the round to the assistant gunner.

(2) The assistant gunner fires the round just as he would service ammunition. After the sabot impacts, it is retrieved, cleaned, and is ready to refire. (Retrieving the sabot after each round is recommended unless a fire-for-effect mission is underway. Retrieval prevents damage to either the sabot being fired or a sabot laying on the ground, which could occur by the rounds impacting together.)

WARNING

Weapons must not be fired during sabot retrieval to avoid injury to personnel downrange. Normally, it is best for only one round to be fired before retrieval to avoid damage to sabots. Do not fire over the head of maneuvering troops.

(3) The barrel should be cleaned after every 10 rounds to reduce the possibility of a misfire, and the sabot should be cleaned after each firing. There is considerable buildup of carbon in the barrel during firing; if not removed, there is a decrease in range.

c. **Forward Observer Procedures.** Regardless of which unit provides the FO fire support, the FO procedures are the same.

(1) The observer-target (OT) factor determined by the FO is based upon a scale of 1:10 rather than thousands of meters--for example, an OT distance of 380 meters is scaled to 3,800 meters, resulting in an OT factor of 4.

(2) The FO measures deviation just as he would in service firing--by using the mil scale in his binoculars or aiming circle, compass, or finger method discussed in FM 23-91, Chapter 4. The FO corrects for deviation by multiplying the measured deviation by the OT factor and announcing his corrections to the nearest 10 scale meters--for example, "Right eight zero (80)."

(3) The FO can use any of the methods of range adjustment that are used during service firing. However, when using the bracketing method, caution should be exercised in establishing the range bracket, since the FO usually assumes his rounds are much closer to the target than they actually are. For example, if the round is 60 meters (600 scale meters) short of the target, the FO should announce, "Add eight hundred (800)," to obtain a range bracket.

(4) Only missions that use point-detonating fuzes can be fired with the sabot. This includes direct-lay and direct-alignment (fire without an FDC) missions. Also, coordinated illumination can be conducted with the illumination provided by handheld flares or flares fired from an M203.

(5) Air observer training can be conducted using a helicopter. The aircraft should fly at an altitude of about 200 feet and to the rear of the firing position. The air observer should be told "SHOT" at least 10 seconds before the mortar fires to properly position the aircraft for observation.

(6) Due to range dispersion, credit for a target hit should be given whenever the subcaliber projectile impacts within ± 25 meters in range and left or right 4 meters of the adjusting point. This "target hit" area could be outlined in engineer tape for each target to help in accurate spotting by the FO, who is the responsible member of the indirect fire team for determining target hits. Table A-2, illustrates the range and deflection dispersion for each subcaliber projectile.

CHARGE	RANGE (in meters)	RANGE DISPERSION (in meters)	DISPERSION (in meters)
1	70-195	± 21	LEFT or RIGHT 2.5
2	140-235	± 26	LEFT or RIGHT 4.0

3	210-330	±30	LEFT or RIGHT 5.0
4	280-435	±39	LEFT or RIGHT 6.0

Table A-2. Range and deflection dispersion.

d. **Fire Direction Center Procedures.** FDC procedures prescribed in FM 23-91 are used without modifications when controlling fires of the 22-mm subcaliber projectile. The most current firing tables for the subcaliber projectile are used when computing ranges, elevations, and maximum ordinate.

e. **Individual Skills.** The sabot is well suited to train, cross train, and test soldiers in individual skills. One method is to establish a series of concurrent stations near a sabot range firing position. Both firing and nonfiring tasks can be performed by having all unit members actively training at the same time and performing several tasks in a short period, which keeps interest high. The suggested concurrent stations are as follows:

- Station 1. Refer and realign aiming posts; boresight.
- Station 2. Ammunition handling, fuze setting, cutting charges (both sabot and service ammunition).
- Station 3. Direct lay (M1 sabot required).
- Station 4. Direct alignment (M1 sabot required).
- Station 5. Indirect fire (M1 sabot required).
- Station 6. Adjustment of fire.

(1) The sabot can be used to simulate the live-fire collective tasks. To support the realistic firing afforded by the sabot, the platoon and section leaders can also perform the following tactical training in conjunction with sabot firing:

- Assembly area procedures.
- Camouflage and concealment.
- Road marches and convoy procedures.
- Reconnaissance of the firing position.
- Occupation of the firing position.
- Displacement by section.
- Maintenance of weapons, vehicles, and equipment.
- Fire support planning.
- Fire support coordination.

(2) The unit can plan an operation for firing the sabot as if live fire were actually going to occur. A sample sequence that allows the unit to train against the ARTEP standards follows:

(a) The platoon/section leader arranges for--

- A time to fire on the sabot range.
- Sabot ammunition.
- Vehicles.
- Weapons.
- Food.
- An assembly area close to the firing position but not in view.

(b) At the appointed time, the unit crosses their starting point en route to the assembly area while practicing--

- Road march and convoy procedures.
- Unit loading plan.

(c) Upon arrival at the assembly area, the unitX

- Opens the fire control net.
- Boresights mortars.
- Constructs firing charts.
- Receives the platoon/section leaders orders for occupation of the firing position.
- Maintains vehicles.

(d) The reconnaissance party departs the assembly area and upon arrivalX

- Locates positions for the mortars, FOs, and FDC.
- Lays wire between the FDC and mortar positions.
- Orients the aiming circle and prepares to lay the section for direction.
- Plans for the occupation of the position by the rest of the section.
- Transmits orders for the rest of the unit to displace to the firing position.

(e) Upon arrival at the firing position, the unit--

- Occupies designated positions.
- Plans fires based on the tactical situation presented in the assembly area.
- Assigns target numbers.
- Lays the mortars.
- Prepares ammunition.
- Conducts firing.

(f) At the conclusion of firing, the unit displaces to its company area to perform maintenance of vehicles, weapons, and equipment.

(g) While monitoring sabot firing, the unit leader can make valuable use of the close proximity of each element to each other. He can allow members of the element to visit another element to observe their duties and procedures. He can also call all unit members together at the conclusion of a task to critique and set the stage for the mission or task.

(3) Live-fire missions, such as Engage an Area Target and Fire Final Protective Fire, can be easily performed with only one firing position for the 81-mm sabot. Tasks that require the mortars to displace can be trained and tested by setting up more than one impact area or by plotting multiple firing points (Figure A-19).

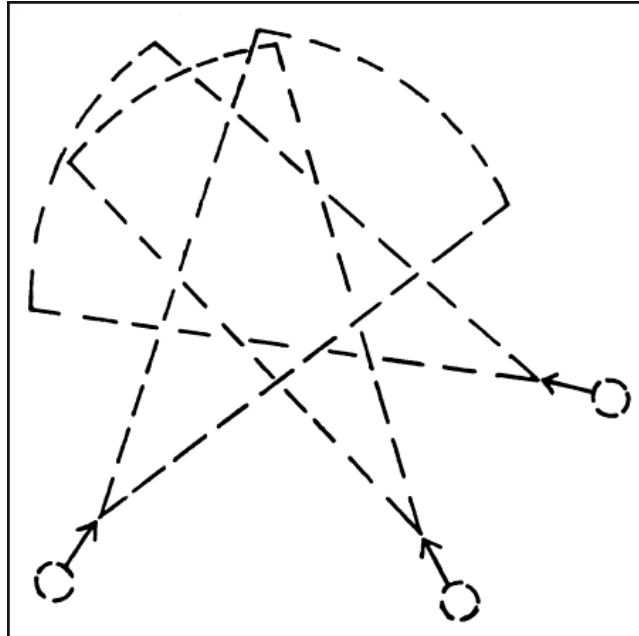

Figure A-19. Multiple firing points.

Section III. SHORT-RANGE TRAINING ROUND

This section provides the technical information required to employ the SRTR. Trainers should exercise imagination and ingenuity in developing training situations for employing the SRTR. The SRTR enables units to train in locations where mortar training facilities are limited or do not exist. The SRTR cartridge provides an economical means of realistically training personnel in all phases of mortar gunnery.

A-19. DESCRIPTION

The SRTR is effective for training all elements of the indirect fire team. It provides the FO with a sound and visual signal by which he can spot rounds and make adjustments. The FDC computes data received from the FO, who observes the impact of the SRTR on a 1:10 scaled range. The gunner places data obtained from the FDC on the mortar and the assistant gunner drops an SRTR down the barrel. The entire indirect fire team functions the same as if they were firing service ammunition with one exception--the FO observes the SRTR impact on a 1:10 scaled range instead of the service ammunition at a normal distance in an impact area. The characteristics of the SRTR are as follows:

- Overall length: 14.5 inches.
- Firing weight: 6.84 pounds.
- Maximum range: 458 meters.
- Minimum range: 47 meters.

Note: The 1:10 scale is based on 81-mm 300-series ammunition.

A-20. COMPONENTS

The SRTR practice cartridge consists of eight major components (Figure A-20).

- Fuze, point detonating M775.
- Projectile body.
- Obturating ring.
- Plastic charge plugs.
- Dud plugs.
- Fin assembly.
- Ignition cartridge, M987.
- Breach plug assembly.

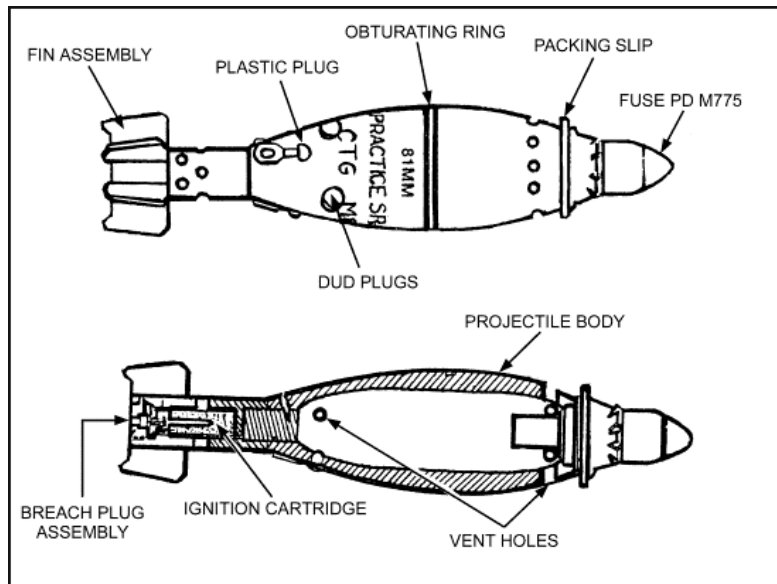

Figure A-20. SRTR practice round.

The SRTR is designed as a training round for the 81-mm mortar (M29 and M252) and the 120-mm mortar (Figure A-20). The SRTR is designed to be fired, recovered, refurbished, and refired. The round is fired from the mortar the same as service ammunition. When fired, the SRTR travels from 47 to 458 meters, determined by charge and elevation. Upon impact, the SRTR emits a flash, bang, and smoke discharge but no fragmentation.

A-21. RANGE RECOMMENDATIONS

A scale of 1:10 is used to relate the range and deviation between the SRTR projectile and the standard 81-mm service projectile. The minimum range requirement for firing, through charge 3, is an area 700 to 900 meters in depth and 300 meters in width. This is necessary to accommodate the desired number of targets and provide a maneuver area to operate in. When using 81-mm mortars, the mortars can be no closer than 4 meters apart, but can be as far apart as the range permits (check with the local range control regulations). The range must be cleared of all unexploded ammunition, concrete, and steel objects (Figure A-21).

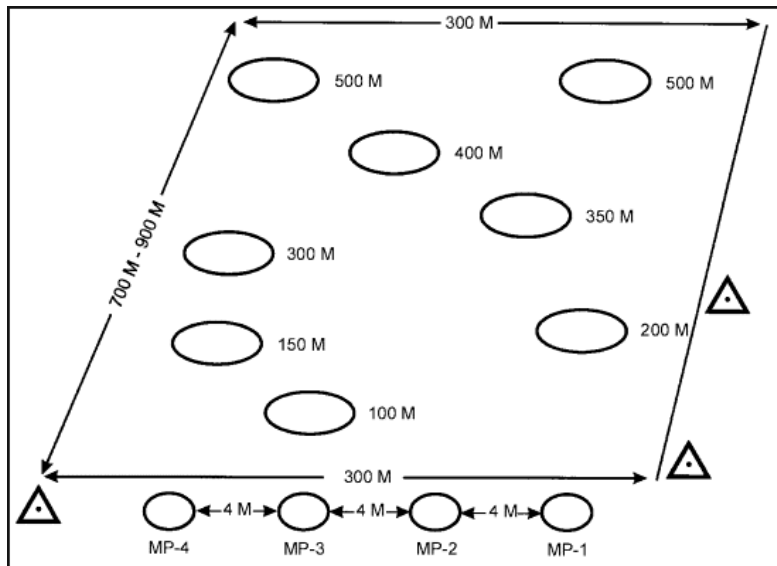

Figure A-21. SRTR scaled range.

A-22. ADVANTAGES

The SRTR is used with all 81-mm mortars and 120-mm mortars by way of the M303 insert. It also accommodates prescribed crew drill procedures, and it can be used by mechanized and ground-mounted elements. The SRTR has the following advantages:

- Provides the ability for firing in training areas where the firing of service ammunition is not allowed.
- Saves time by eliminating long-distance traveling to suitable mortar ranges.
- Saves in cost of firing service ammunition.
- Can be taught to operate and maintain in a short period of time.
- Has the same procedures used by the entire indirect fire team when firing service ammunition, excluding appropriate charge and fuze settings.
- Uses all of the equipment required when firing service ammunition.

A-23. AMMUNITION

The projectile body is made from cast iron and is machined to accept the M775 fuze, the tail fin, three charge plugs, three dud plugs, and the obturator ring. It is painted blue with white lettering and one brown band to identify it as a practice round. The charge and dud plugs are fitted into holes drilled in the base of the projectile body. The obturator ring is plastic and shaped like a split ring so that it will expand to fit over the projectile body and

will seat into the band groove. The M775 fuze assembly includes a pyrotechnic spotting cartridge, which is retained in the fuze body by a threaded aluminum cup. This assembly is threaded into the nose of the projectile body. The M775 fuze replicates the M734 multi-option fuze used with service ammunition. Even though the M775 has four fuze settings for ammunition bearer training, it will only function upon impact. The tail fin assembly is threaded onto the stud at the base of the projectile body. Inside the tail fin is the propellant cartridge. It is a primed 12-gauge shotgun shell casing loaded with a double base propellant. The breech plug/firing pin is threaded into the rear of the tail fin and retains the propellant cartridge in the fin cavity.

a. Prepare the M880 short-range training ammunition for firing.

(1) The M880 is issued ready to fire. When the round is unpacked, inspect the following:

- No red showing on top of fuze.
- Packing clip is in place.
- Obturating ring is present and flush with body.
- Three plastic charge plugs seated in body.
- Three dud plugs seated in body.
- Ignition cartridge inside fin assembly.
- Breech plug seated in fin assembly.

WARNING

1. If red can be seen above the windshield on the fuze, the fuze has been armed. Place the entire round in the dud pit until you are ready to defuze the round.

2. If the packing clip is loose, attempt to place the packing clip back into the fuze. If it will not go back into the fuze, place the entire round into the dud pit until you are ready to defuze the round.

(2) To prepare a newly issued round for firing, set the desired charge by pulling one of the plastic charge plugs from the body of the round. Set the desired fuze setting by rotating the multi-option fuze clockwise or counterclockwise until the desired fuze setting is lined up with the notch on the body of the round. Present the round to the squad leader for his inspection. When the assistant gunner is ready to fire the round, pull the packing clip from the round and hand it to him.

WARNING

Do not pull the packing clip from the round until the assistant gunner is ready to fire the round.

Note: The fuze setting is for training only and will not affect the functioning of the fuze.

(3) Charge settings for the round are as follows:

- (a) Charge 0--pull all the plastic charge plugs from the body.
- (b) Charge 1--pull two of the plastic charge plugs from the body.
- (c) Charge 2--pull one of the plastic charge plugs from the body.
- (d) Charge 3--do not pull any of the plastic charge plugs from the body.

(4) To refurbish a previously fired round, ensure that the round is clean. All portholes must be free of dirt to allow the gas to escape, and all of the threads must be clean.

(5) Inspect the refurbishing kit to ensure that all equipment is present.

- Three plastic charge plugs.
- One obturating ring.
- One M987 ignition cartridge.
- One breech plug.
- One M775 point detonating fuze.
- Three dud plugs.

WARNING

1. If any red can be seen above the fuze windshield, place the fuze in the dud pit and dispose of the fuze IAW unit sop.

2. If the packing clip is loose, attempt to place the packing clip back into the fuze. If it will not go back into the fuze, place the fuze into the dud pit and dispose of the fuze IAW unit sop.

3. Inspect the breech plug firing pin for freedom of movement. If it does not move freely, a misfire could occur or premature ignition of the ignition cartridge could take place when assembling the round.

(6) To assemble the round do the following:

- (a) Install the three plastic plugs with the tangs pointed to the rear of the projectile body.
- (b) Install the three dud plugs.
- (c) Secure the fin assembly onto the projectile body hand tight.
- (d) Install the obturating ring onto the projectile body.

CAUTION

If the obturating ring does not seat flush or below the surface of the projectile body, send the body back to the maintenance table for further cleaning. If the obturating ring still does not seat flush, the body must be disposed of.

- (e) Install the fuze assembly hand tight and flush with the top of the round.
- (f) With the round laying horizontally on the table, install the M987 ignition cartridge into the tail fin assembly.

WARNING

Do not force the ignition cartridge into the tail fin assembly.

- (g) Install the breech plug by hand and use the breech plug wrench to secure the breech plug hand tight.
- (7) Place the round back into its canister until it is ready to be fired.

Note: Do not refurbish the M880 round if it will not be fired that same day.

- (8) To fire the round, follow the same procedures as if the round was newly issued.

b. Clean and service the M880 SRTR.

- (1) Fill two trash cans with water and leave another trash can empty.
- (2) Dip the spent M880 into the first water bucket and scrub off the heavy dirt with a wire brush.

- (3) Place the M880 round on the work table and secure the projectile body with the strap wrench.
- (4) Remove the fuze (if necessary, use the long handle pliers) and discard.

WARNING

When the fuze is removed from the body, it must be inspected to ensure that it has detonated by inspecting the coin to see if it is missing.

- (5) Using the breech plug wrench, unscrew the breech plug and discard.
- (6) Using the fin wrench, unscrew the fin assembly from the projectile body.
- (7) Place the tail fin assembly upright on the cartridge block, place the punch into the tail fin assembly, strike the punch with the ball peen hammer, and drive out the spent ignition cartridge. Discard the spent ignition cartridge.
- (8) Place the tail fin assembly into the second wash bucket and clean it with a wire brush for the final cleaning. Ensure that all dirt and residue are removed from the round.
- (9) Remove all remaining plastic plugs and the obturating ring from the projectile body and discard them.
- (10) Place the projectile body into the second wash bucket and remove all dirt and residue. Take the M16 bore brush and thoroughly clean the vent holes and the thread.
- (11) With a clean, dry rag, dry both components of the M880. Ensure no dirt or residue are present on the projectile body and tail fin assembly.
- (12) Examine the M880 for cracks and any type of damage that may prevent the projectile from being refired. If there is evidence of cracks or some type of damage, discard the entire projectile body and tail fin assembly.
- (13) If the M880 is not going to be fired the same day, lightly oil the projectile body and tail fin assembly. Screw the tail fin assembly back on the body and store it in its canister.

Note: The M880 must be recovered, cleaned, and serviced within 24 hours after it is fired.

c. Recover a previously fired M880 round from downrange.

WARNING

Failure to follow the proper recovery procedures may result in personal injury.

- (1) Ensure the range is closed and all weapon systems have ceased firing.
- (2) Issue a shovel, a grappling hook, heavy duty leather work gloves, and an ammunition box to the assistants.
- (3) Walk downrange with the assistants and locate the M880 round.
- (4) Pick up the round and verify that the round has functioned by observing that all of the dud plugs on the body are missing. Have a second soldier verify that all of the dud plugs are missing.

WARNING

When picking up the M880, ensure that your hand and fingers are not covering the vent holes.

- (5) If all of the dud plugs are missing, place the round in the ammunition box.

WARNING

If any of the dud plugs are present and the fuze has not functioned, place the round in a marked pit and follow the defuzing procedures outlined in paragraph A-23d.

Note: It may be necessary to dig the round out with the shovel. The grappling hook may be used to assist in recovering the round.

- (6) Ensure that each hole left by the M880 round is filled.
- (7) Once the M880 rounds have been recovered, transport them to the maintenance table.

d. Defuze a dud M880 round.

Note: The dud M880 round may be defuzed when first located or at the end of that day's firing as long as it is recovered within 24 hours after it has been fired.

(1) Set the defusing device (boom box) on the platform with the holes facing downrange and away from the troops. Pull out the four retaining pins that secure the top portion of the boom box, then pull the top off the base of the boom box.

(2) Turn the round until the packing clip portion of the round is facing upward.

(3) With the chisel over the fuze, secure the top portion of the boom box to the base, then attach the four retaining pins.

(4) Kneeling on the opposite side of the holes on the boom box, strike the chisel with the 4-pound hammer until the chisel moves freely from the base of the boom box to the top of the boom box.

WARNING

1. All personnel must be on the solid side of the boom box before the chisel is struck with the hammer.

2. When defuzing an M880 round, ear plugs and goggles must be worn.

(5) Remove the cover of the boom box and inspect the fuze to verify that the spotting charge has functioned.

WARNING

If the spotting charge has not functioned or the fuze has pulled away from the thread well, transport it to the dud pit and dispose of it IAW the unit SOP.

(6) Remove the M880 round from the boom box and return the cartridge to the firing line for cleaning.

A-24. TRAINING USAGE

SRTR training enables the unit commander to observe the actions of the indirect fire team and the tasks being performed by the indirect fire team. This enhances the ability of the commander to evaluate the proficiency of all elements of the training, to identify and isolate problems, and to begin corrective training. All members of the team can view the overall operation to understand each member's part.

a. The time used for preparation determines the benefits gained from training with the SRTR. Three steps must be accomplished before training begins:

(1) Build a scaled firing range (permanent, semi-permanent, or temporary).

(2) Construct a map of the firing range.

(3) Train the personnel with the SRTR. Personnel should be trained in the recovery, refurbishment, and maintenance of the M880 before range firing begins.

b. Gunners should not be allowed to observe the impact of the SRTR, unless firing a direct-lay mission. Normally, mortars are mounted in a defilade position so that mask exists between the impact area and the firing position. If mask does not exist, using a referred deflection of 0700 when firing is recommended.

c. When positioning 81-mm mortars, the lateral distance between the center of each baseplate should have a minimum distance of 4 meters (40 meters when firing service ammunition, 1:10 scale for the SRTR = 4 meters).

d. The SRTR can also be fired from the 120-mm mortar using the M303 81-mm insert. When positioning 120-mm mortars, the lateral distance between the center of each baseplate should be a minimum of 6 meters (60 meters when firing service ammunition, 1:10 scale for the SRTR = 6 meters).

A-25. CONSTRUCTION OF A SCALED MAP

The range limitations associated with the M880 SRTR make a standard 1:50,000-scale military map difficult to use. Therefore, a new map 1/10 the size (1:5,000) must be constructed.

a. Use a blank sheet of paper to draw grid squares the same size as the 1:50,000-scale map and renumber them based on 100 meters per square.

b. Determine the 8-digit grid coordinates to the mortar position on a 1:50,000-scale military map and convert it to a 1:5,000 scale (Figure A-22).

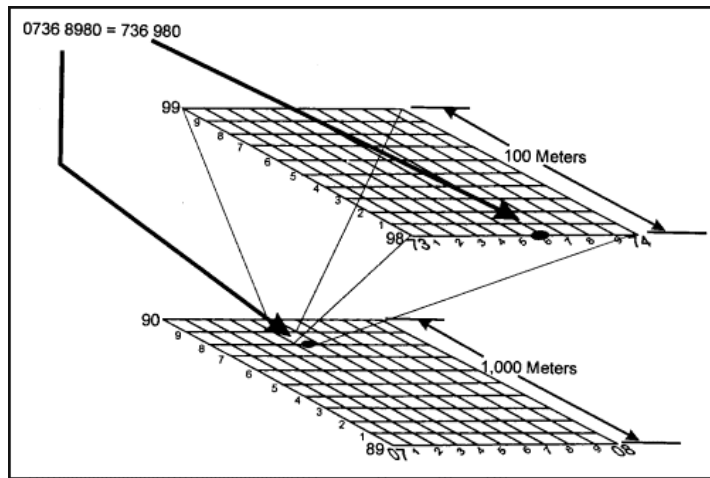

Figure A-22. Converting 1:50,000 grid to 1:5,000 grid.

Note: The first number of a grid coordinate is the 10,000-meter designator; the second number is the 1,000-meter designator; the third number is the 100-meter designator; and the fourth number is the 10-meter designator.

(1) To make a 1:5,000-scale map, drop the 10,000-meter designator and use the 1,000-meter designator as the first number for each grid. For example, a mortar location of 07368980 becomes 736980. The 7 and the 9 will precede each grid location since they identify the 1,000-meter increments. To make an 8-digit grid from this 6-digit grid, add a 0 at the end of the easting and northing grid location. For example, the mortar grid becomes 73609800. The 0 is the 1-meter designator.

(2) Before constructing the 1:5,000-scale map, determine the direction of fire from the mortar position to the RP. (Surveying a point on the range should be done at least one day before training. If a point on the range has already been surveyed, it can be used to make the map.) For example, if the direction of fire is southeast, the mortar position would be in the northwest corner of the grid sheet. Using the example grid coordinates, the most westerly grid line would be 73 and the second most northerly grid line would be 98. Number the rest of the grid lines accordingly.

c. To plot the mortar position on the 1:5,000-scale map, use the same protractor that is used for the 1:50,000-scale map, but instead of the protractor measuring 1,000 meters, it will measure 100 meters.

d. To determine the direction of fire, place a target downrange, set up the M2 aiming circle at the base gun position, and measure an azimuth to the target. To accurately plot targets on the map, measure the distance by pace count from the base piece to the target and then plot it on the map. This procedure allows the creation of a surveyed firing chart. The FO's location can be plotted in the same manner. After all plotting is done, give a copy of the map to the FO (Figure A-23). He can call for fire using this map the same as if firing service ammunition.

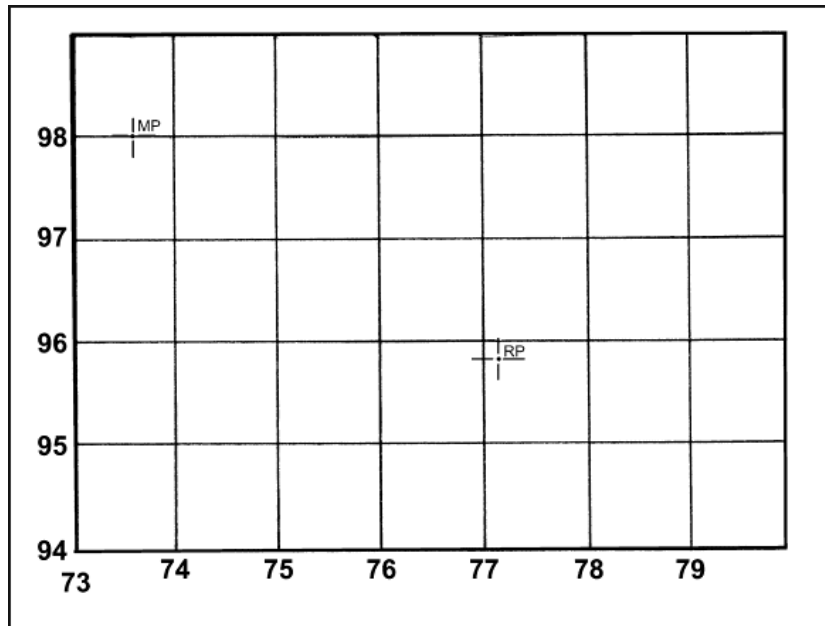

Figure A-23. Plotting targets on the 1:5,000-scale map.

e. Before putting the map on the M16 plotting board, determine the grid intersection to represent the pivot point in the same manner as if firing service ammunition.

(1) Place the grid system on the plotting board the same as if firing service ammunition. Number every other black line. Every small green square equals 5 meters and every black square equals 50 meters.

(2) Place the mortar position and target on the plotting board the same as if firing service ammunition. The grids plotted are to the nearest 1 meter instead of 10 meters.

f. To determine the mounting azimuth, line up the mortar position and the RP. Read the azimuth on the azimuth scale at the top of the plotting board. Round off the azimuth to the nearest 50 mils, and superimpose this azimuth over the referred deflection. Number the azimuth scale every hundred mils using the LARS rule (Figure A-24).

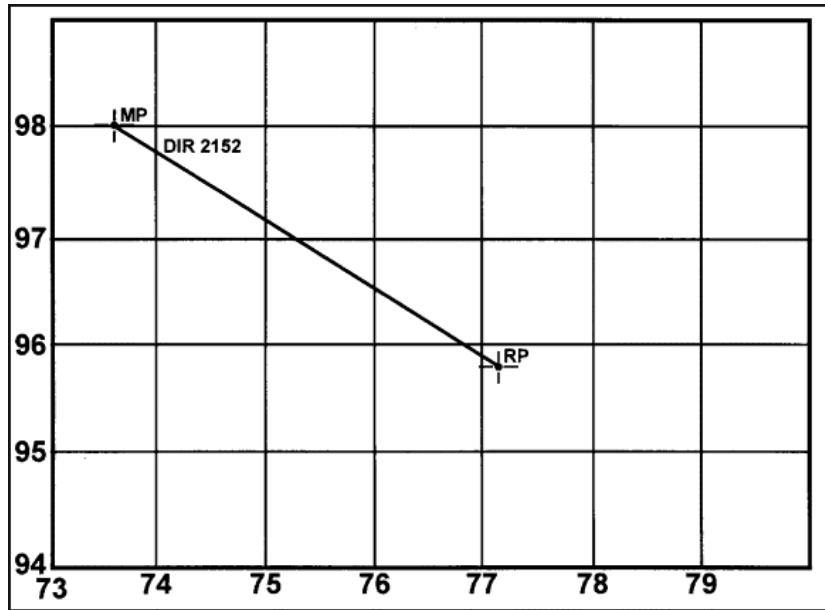

Figure A-24. Determining direction from MP to RP.

g. When firing the M880 SRTR, range control must know exactly where the firing position is. The 1:50,000-scale grid must be annotated on the data sheet (DA Form 2188-R), labeled, and placed in the BP box (Figure A-25).

DATA SHEET						
For use of this form, see FM 23-91. The proponent agency is TRADOC.						
SETUP		WEAPON DATA			FO DATA	
TIME OUT:	UNIT:	WPN:	WPN:	FO:	ALT:	GRD:
TGT PRFX: <u>AB</u>	<u>ECC 2129 IN</u>	DIR:	DIR:			
TGT NO: <u>0100-0150</u>	<u>81 mm CAR: YES</u>	DIS:	DIS:			
ALARM: <input type="checkbox"/> ON <input type="checkbox"/> OFF	<u>(M880) NO</u>					
MIN E:	BP: <u>150,000773</u>	WPN:	WPN:			
MIN N:	<u>0736 8980</u>	DIR:	DIR:			
GD: <input type="checkbox"/> E <input type="checkbox"/> W	E: <u>7360</u>	DIS:	DIS:			
LAT: <input type="checkbox"/> + <input type="checkbox"/> -	N: <u>9800</u>					
LISTER: <input type="checkbox"/> ON <input type="checkbox"/> OFF	ALT:	WPN:	WPN:			
BIT RATE:	AZ: <u>2152/2150</u>	DIR:	DIR:			
KEY TONE:	DEF: <u>2800</u>	DIS:	DIS:			
BLK: <input type="checkbox"/> SNG <input type="checkbox"/> DBL	ELE:					
OWNER ID:						
AMMUNITION DATA						
TEMPERATURE:	TYPE: <input type="checkbox"/> HE <input type="checkbox"/> WP <input type="checkbox"/> RL <input type="checkbox"/> CS <input checked="" type="checkbox"/> TNG (<u>M880</u>)					
LOT NUMBER						
WEIGHT						
ON HAND						
RECEIVED						

Figure A-25. Example completed DA Form 2188-R.

h. The computer's record (DA Form 2399) is also altered. For safety, as well as range control's information, "M880" should be placed in the "SHELL AND FUZE" spaces in both the FDC ORDER and INITIAL FIRE COMMAND (Figure A-26).

FDC ORDER	INITIAL CHART DATA	INITIAL FIRE COMMAND	ROUND'S EXPENDED
MORTAR TO FFE: <u>SEC</u>	DEFLECTION: <u>2807</u>	MORTAR TO FOLLOW: <u>SEC</u>	①
MORTAR TO ADJ: <u>#2</u>	DEFLECTION CORRECTION: <input type="checkbox"/> L <input type="checkbox"/> R	SHELL AND FUZE: <u>HEQ</u> <u>(M880)</u>	
METHOD OF ADJ: <u>IRD</u>	RANGE: <u>206</u>	MORTAR TO FIRE: <u>#2</u>	
BASIS FOR CORRECTION:	WALT CORRECTION: <input type="checkbox"/> + <input type="checkbox"/> -	METHOD OF FIRE: <u>IRD IN ADJ.</u> <u>IRDS IN FFE.</u>	
SHEAF CORRECTION:	RANGE CORRECTION: <input type="checkbox"/> <input type="checkbox"/>	DEFLECTION: <u>2807</u>	
SHELL AND FUZE: <u>HEQ</u> <u>(M880)</u>	CHARGERANGE: <u>0</u>	CHARGE: <u>0</u>	
METHOD OF FFE: <u>IRDS</u>	ADMUTH: <u>2143</u>	TIME SETTING:	
RANGE LATERAL SPREAD:	ANGLE T: <u>1630</u>	ELEVATION: <u>1201</u>	
ZONE:			
TIME OF OPENING FIRE: <u>W/B</u>			

Figure A-26. Example completed DA Form 2399.

A-26. SAFETY

The SRTR is safe to handle and fire. The following safety precautions must be enforced.

<p style="text-align: center;">WARNING</p> <p>The SRTR is inert and can be stored and handled as a weapon until it is loaded with the refurbishment kit at which time it will be handled as a live mortar round. When loaded and ready to fire, all safety precautions used during handling of service ammunition are observed.</p>

- a. The SRTR refurbishment kit contains a propellant and smoke charge, and is always stored and handled as live ammunition.
- b. Practice ammunition is never fired over the heads of troops.
- c. Personnel never go forward of the firing line until a cease fire has been called by the range OIC or safety officer.

Note: Duds are disposed of as prescribed in paragraph A-23.

A-27. MALFUNCTIONS

See Chapter 3, paragraph 3-13 for a detailed discussion of malfunctions.

A-28. REMOVAL OF A MISFIRE

After failure to fire, misfire removal procedures are followed to remove the round from the weapon. Misfire procedures for live rounds also apply when firing the SRTR.

- a. If the primer cap of the SRTR is dented, the whole round is placed in the dud pit for disposal IAW the local SOP.
- b. If the primer is not dented, the round can be refired upon determination of the cause of the misfire.

A-29. SUPPLY DATA

The equipment shown in Table A-3 is available at the ammunition supply facility:

DESCRIPTION	NATIONAL STOCK NO.	PART NO.	DODAC NO.
Cartridge, 81-mm Practice: M880	1315-01-216-7070		1315-C876
Refurbishment kit, M80	1315-01-219-3936	19200	1315-C045

Table A-3. Supply data for SRTR.

Section IV. M303 SUBCALIBER INSERT

The M303 subcaliber insert (Figure A-27) is a low-cost training aid that provides effective training for the entire platoon, including the FO, on a live-fire exercise. It uses 300-series HE, WP, and illumination ammunition. Currently, the FDC will use the M16 plotting board for plotting. The subcaliber insert will be issued to the unit for accountability. The unit is also responsible for maintaining the insert and the DA Form 2408-4.

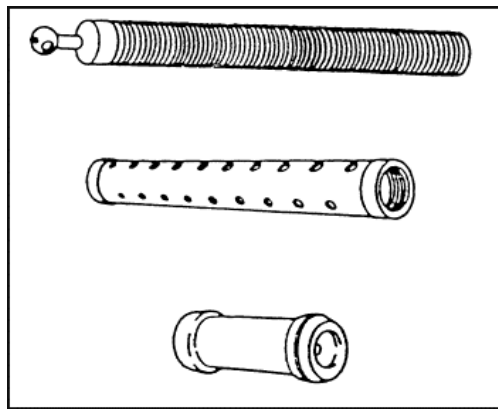

Figure A-27. M303 subcaliber insert.

A-30. CHARACTERISTICS

This paragraph describes the characteristics of the M303 subcaliber insert.

- a. The 300-series ammunition has a minimum range of 73 meters and a maximum range of 4,789 meters. It can be fired at a sustained rate of three (charge 8) or five (charge 6). It can be fired indefinitely at a period rate of fire. The 300-series

ammunition has a maximum rate of fire of 12 (charge 8) for two minutes and 12 (charge 6) for five minutes.

b. The barrel is a M29A1 that has been refurbished. This is the only M29 barrel approved to use the M303 subcaliber insert. The barrel is 51 inches long and weighs 28 pounds. It has a smooth bore with one circular cooling ring and a removable firing pin.

c. The insert sleeve is 42 inches long and weighs 5.9 pounds. It is tubular shaped with cooling holes. It has a threaded end on top and a smooth end on the bottom. The sleeve slides over the barrel and is threaded onto the barrel until it is flush with the breech cap. It is held in place by three hex screws on the muzzle end. Approximately 2 inches of the M29 cannon will be showing at the muzzle end.

Note: After every fire mission, the hex screws on the upper sleeve ring should be checked for tightness to ensure the interior of the 120-mm cannon is not damaged.

d. The filler block is 15.9 inches long and weighs 17 pounds. It is tubular shaped with the top and bottom the same diameter as the interior of the 120-mm cannon. The top and bottom have a concave slope with a threaded hole, which is used in the removal of the filler block.

e. The M303 subcaliber insert comes with a filler block adapter, a 0.0625-inch hex wrench, and a firing pin wrench.

A-31. MAINTENANCE

Maintenance must be performed on the M303 subcaliber insert before, during, and after firing. This paragraph describes the procedures to follow to perform this maintenance.

a. Before.

(1) Cannon.

(a) Update the DA Form 2408-4 to reflect days firing. Ensure that all standards for bore scope and pullover gauging have not been exceeded (within the past 180 days).

(b) Check the M120/M121 mortar for cracks, broken welds, rust, and missing or damaged parts.

(c) Check the M29A1 cannon for foreign matter in the barrel, then wipe dry. Clean and lubricate the exterior surface. Check for bulges, dents, and visible cracks. Check for evidence of gas

leakage (grayish color) around the firing pin located in the base of the spherical projectile.

(d) Check the insert sleeve for cracks, broken welds, rust, and missing or damaged parts. Check that the insert sleeve assembles onto the cannon assembly, can be secured with set screws, and is free of any nicks and burrs.

(2) *Filler block.*

(a) Check the filler block for cracks, broken welds, rust, and nicks or burrs.

(b) Check that the filler block fits with breech plug of the M29A1 cannon, seats in the base of the 120-mm bore, and can be employed or retrieved using the adapter tool.

b. During.

(1) Check the bore after approximately every 50 rounds for bulges, dents, and visible cracks. Check for evidence of gas leakage around the firing pin (grayish discoloration).

(2) Dry swab the barrel bore after firing every 10 rounds or after every end of mission (EOD).

c. After.

(1) Check DA Form 2408-4 to ensure it reflects the days firing.

(2) Ensure rifle bore cleaning compound (RBC) is used to thoroughly clean the barrel bore after firing and for two consecutive days thereafter. Be sure to wipe dry and lubricate with GPL after each cleaning.

Note: For nonfiring periods, clean and lubricate the barrel on a weekly basis.

(3) Check the insert sleeve for cracks, broken welds, rust, nicks, burrs, and damaged parts.

(4) Check the filler block for cracks, broken welds, rust, nicks, burrs, and damaged threads.

(5) Intervals are based on usual conditions. For unusual operating conditions, lubricate more often. When the weapon is not being used, the intervals may be extended if proper lubrication procedures have been

followed. Clean the barrel bore weekly with RBC, and lubricate the barrel, firing pin, insert sleeve, and filler block weekly with GPL.

WARNING

Dry cleaning solvent is flammable. Do not clean parts near an open flame or in a smoking area. Dry cleaning solvent evaporates quickly and has a drying effect on the skin. When used without protective gloves, this chemical may cause irritation to, or cracking of, the skin.

Note: Before firing, dry swab the barrel bore of the M29A1 and the 120-mm cannon. Wipe dry the exterior of all components of the subcaliber insert.

A-32. MISFIRE PROCEDURES

This paragraph describes the misfire procedures for an M303 subcaliber insert.

- a. When a misfire occurs, any member of the squad who notices a misfire immediately announces, "MISFIRE!"
- b. All personnel except the gunner move 100 meters to the rear of the mortar. When carrier-mounted, they exit through the cargo hatches and climb over the front of the carrier.
- c. The gunner stands to the left rear and kicks the cannon several times with the heel of his boot to attempt to dislodge the round. If the round fires, the mortar is re-laid and the fire mission continues. If the round fails to fire, the gunner moves to the rear of the mortar, joins the crew, and waits one minute.

WARNING

Keep the head and body away from the front of the cannon. Do not stand behind the cannon. At no time will the buffer housing assembly be loosened.

- d. After one minute, the gunner returns to the mortar (if carrier-mounted, he remounts the carrier over the front) and feels the cannon for heat using his fingertips.

WARNING

on the exterior of the cannon or the rate of fire exceeded the sustained rate (four rounds per minute), the gunner rejoins the crew and waits an additional three minutes. (When excessive heat is felt below or around the lower collar stop on the cannon, the subcaliber insert is too hot to handle.)

e. After three minutes, the gunner returns to the mortar (if carrier-mounted, he remounts the carrier) and feels the 120-mm cannon for heat. If the 120-mm cannon still radiates excessive heat, he attempts to cool it with water or snow.

Note: Low and high range pertains to carrier-mounted only.

f. If the cannon is cool enough to handle, the gunner locks down the data on the sight, removes the sight (and extension if carrier-mounted), and places them in a safe place. He then calls the crew forward. The gunner grasps the insert just below the muzzle with both hands ensuring no part of his body is in front of the muzzle and his fingers are not in the holes of the insert. On an M374 HE series misfire, he slides the insert approximately 12 inches out of the 120-mm cannon and releases the insert taking one step with his left foot, bending at the waist, and bringing his hands down alongside the cannon. (The same as if he were firing a round.) On an M301 illumination series misfire, he slides the insert approximately 3 to 6 inches out of the 120-mm cannon. This procedure is to attempt to dislodge the round before removing the insert. If the round fails to fire, the gunner depresses the cannon to its lowest elevation, leaving approximately 1/4 turns on the elevation shaft. If the mortar is in low range (carrier-mounted), the gunner depresses the cannon to its lowest elevation.

Note: With an M301 illumination series misfire, if the round fails to fire after releasing the insert 3 to 6 inches out of the cannon, the gunner rejoins the crew for 5 minutes. If the round does not initiate, he continues the procedures in paragraph f.

g. The assistant gunner grasps the insert just below the muzzle with both hands. Ensuring that no part of his body is in front of the muzzle, he lifts the insert. When the upper sleeve ring of the insert sleeve clears the mortar, the gunner grasps the sleeve and helps in removing the insert.

h. When the insert clears the 120-mm cannon, the gunner holds the insert while the assistant gunner positions himself to receive the round. (If carrier-mounted, the gunner stabilizes the insert while the assistant gunner exits the carrier. For added support, the gunner may rest his left elbow on the cross-member of the carrier.) The assistant gunner places his hands just behind the muzzle of the insert. At this time, the assistant gunner gives the command to lift the insert. NEVER LOWER THE BASE OF THE INSERT BELOW HORIZONTAL BEFORE THE

ROUND HAS BEEN REMOVED. The assistant gunner places the meaty portions of his thumbs at the muzzle end and waits for the round to exit the tube. The assistant gunner grasps the round, removes it from the tube, and gives it to the ammunition bearer who disposes of the round according to SOP. The insert is turned upside down to shake out any debris, inserted back into the 120-mm mortar, swabbed, and re-laid to continue the fire mission.

Note: If the round is not dislodged, take the entire insert downrange and place it in a dud pit or a designated area ensuring that the cannon is pointing in the direction of fire. Notify EOD personnel.

APPENDIX B

MORTAR TRAINING STRATEGY

This appendix provides a comprehensive unit training strategy for training mortarmen. Leaders have the means to develop a program for training their mortar units to full mission proficiency. This training strategy applies to all mortars in all organizations of the US Army. Although not prescriptive in nature, it must adapt to a unit's mission, local training resources, commander's guidance, and unit training status.

B-1. TRAINING PHILOSOPHY

This training strategy synchronizes institutional and unit components to produce units that are trained to win on the battlefield. It includes the training documents, institutional training, unit training, and training resources needed to achieve and sustain the required outcome. It covers the skills required for individual, crew, leader, and collective proficiency and ensures that the strategy is linked horizontally within CMF and vertically between officer and enlisted. This strategy integrates information from several publications, including this manual, into a single-source document (see References).

B-2. UNIT MORTAR TRAINING

Technical and tactical proficiency is based on sound training. The importance of skilled and proficient mortarmen must not be overlooked within the context of the battalion's overall training strategy. Unless leaders have a mortar background, they may not understand the distinct training requirements and tactical role of mortars. This ensures they will allocate priorities and resources to mortars, which are required for effective training. Therefore, leaders may also require training. This can be achieved by OPD and NCOPD instruction on mortars, which include both technical and tactical mortar subjects.

a. Once mortarmen have mastered their own tasks, they must be fully integrated into the training exercises of the company, battalion, or both. Only within the context of a full maneuver exercise can the mortar unit's indirect fire support ability be fully trained and evaluated. However, mortars suffer from not having a training device (such as MILES) to simulate the terminal effects of mortar rounds. As a result, maneuver units tend to under-employ their supporting mortars. Despite the current absence of such devices, there are other techniques to assess the effects of indirect fire. (These are outlined in GTA 25-6-7 and Appendix F of FM 25-4.) Fire missions not specifically using enemy targetsXsuch as registration and adjusting final protective fireXshould also be routinely conducted in maneuver exercises.

b. A training plan that employs mortarmen only as OPFOR riflemen is not effective for many reasons. Firstly, mortarmen are not being trained in the technical and tactical tasks pertinent to their mission. Secondly, riflemen are deprived of a valid training experience as OPFOR. Thirdly, maneuver units are not trained to employ their mortar indirect fire support.

B-3. MORTAR TRAINING AT TRAINING BASE

The mortar unit training strategy begins with the training base. Leaders must know what skills mortarmen bring with them when they report to their unit. This forms the base to build mortar training in the unit. The career pattern for NCOs and officers (lieutenants) is depicted in individual training. It entails alternating between the training base and units with progressively advanced levels of training and responsibility. Mortar training in the institution focuses on preparing the soldier for these positions. Depending on the course, the training focus includes technical training in mortar skills, mortar familiarization, and mortar issues update (Table B-1).

COURSE	SKILL LEVEL					COURSE FOCUS
	1	2	3	4	OTHER	
One Station Unit Training	X	X				A
Basic NCO Course		X	X			C,D
Advanced NCO Course				X		C,D
Infantry Mortar Leader Course			X	X	X	B,C,D
Officer Candidate School					X	C
Infantry Officer Basic Course					X	C
Infantry Career Captain Course					X	D
Pre-Command Course					X	C,D
A = MOS-PRODUCING B = ADDITIONAL SKILL IDENTIFIER FOR OFFICERS C = FAMILIARIZATION D = REVIEW/UPDATE						

Table B-1. Institution courses.

a. **One Station Unit Training (11C).** OSUT trains new soldiers for their initial assignment in infantry or mechanized units. Training is divided into two phases. Phase I (seven weeks) teaches common entry-level infantry tasks. Phase II continues to foster the self-discipline, motivation, physical readiness, and proficiency in combat survivability started in Phase I. The 11C soldiers receive instruction in mortar systems to prepare them for their specific unit assignments (light units 60-mm and 81-mm mortars; heavy units 81-mm, 4.2-inch, and 120-mm mortars). Soldiers receive familiarization on FDC and FO procedures and are required to pass a mortar gunner's examination to be awarded their MOS.

b. **Basic Noncommissioned Officer Course (11C).** BNCOC teaches junior NCOs to lead, train, and direct subordinates in the maintenance, operation, and employment of weapons and equipment. The instruction includes FDC procedures, fire planning, tactical employment of mortars, and maintenance.

c. **Advanced Noncommissioned Officer Course.** ANCOC prepares NCOs to lead a mortar platoon in combat as part of the battalion team. This includes fostering an understanding of the battalion task force concept and how it fights. Training that applies to mortars includes fire planning, FDC, and FO procedures.

d. **Infantry Mortar Leader Course.** IMLC provides lieutenants and NCOs (sergeant through master sergeant) with the working knowledge to supervise and direct the fire of a mortar platoon. Instructions include tactical employment of the mortar platoon, graphics, fire planning, mechanical training, FO procedures, and mortar ballistic computer procedures. Officers are awarded the additional skill identifier of 3Z. Commanders must ensure that IMLC graduates fill mortar leadership positions. The skills personnel have learned are complex and perishable and must be sustained in the unit.

e. **Infantry Officer Basic Course.** IOBC trains lieutenants in weapons, equipment, leadership, and tactics. It also teaches them how to instruct their subordinates in the maintenance, operation, and employment of weapons and equipment for combat. Students receive instruction in mechanical operation of the mortar as well as detailed instruction on FO procedures.

f. **Infantry Career Captain Course.** ICCC trains first lieutenants and captains in leadership, war fighting, and combat service support skills required to serve as company commanders and staff officers at battalion and brigade levels. Mortar training focuses on supervisory tasks.

g. **Pre-Command Course.** PCC is intended for field-grade officers (majors through colonel) designated for battalion and brigade command. Training consists of a review and update on mortar issues such as battle drills and safety.

B-4. TRAINING IN UNITS

A unit training program consists of initial and sustainment training. Both may include individual and collective skills. Resources, such as devices, simulators, simulations, ranges, and ammunition, further develop skills learned in the institution. The critical aspect of unit training is to integrate soldiers into a collective, cohesive effort as a mortar squad or platoon member. Drills, STXs, and live fire drills develop these collective skills.

a. **Training Plan Development.** Training plans are developed at higher headquarters and published in the form of command guidance so that subordinate units can develop their plans. The process begins with identifying the unit's METL. The METL contains all the collective tasks that a unit must perform to be successful in combat. FM 25-100 contains specific information on the METL development process.

(1) Commanders assess the unit's proficiency level in each METL task. Information for this assessment is obtained by reviewing past gunner's and FDC examinations, ARTEP results, and external evaluation AARs, and by observing the execution of current training.

(2) Once the assessment is complete, the commander lists the tasks in priority. Tasks that are identified as untrained (U) and are critical to the mission have training priority, followed by tasks that need practice (P) and tasks that are trained (T) to standard. Resources (ranges, ammunition, equipment, and time) are requested to train those tasks that do not meet the standard (U and P), while sustaining the proficiency of the tasks that do meet the standard (T). The commander refines his plan in the form of a training guidance and training schedules. FM 25-2 contains specific information on the training plan development process.

(a) Initial training trains soldiers and units to a high degree of proficiency. New soldiers have not yet trained on all tasks associated with the mortar. Initial training ensures that each soldier, squad, and platoon has the basic core skills proficiency for their skill levels or their collective team. Initial training must be trained correctly to a rigid standard so that proficiency will be retained longer. Decay in skill proficiency will occur due to available training time, skill difficulty, or personnel turnover.

(b) Sustainment training reduces skill decay and maintains proficiency within the band of excellence described in FM 25-100. Retraining may be required if a long period elapses between initial and sustainment training. Once proficiency is demonstrated in a task or collective event, more difficult scenarios and exercises should be developed to train to a higher level of proficiency, while sustaining previously learned skills.

b. **Integrated Training Strategy.** Figure B-1 outlines a logical progression of events that a mortar platoon can adapt to their training strategy. Mortar squads and the FDC are dual-tracked to focus on their specific training needs. Both tracks must be integrated to develop a mortar platoon that fights as one unit. Individual and collective training must be evaluated against specific standards and discussed in AARs. Objective evaluations provide readiness indicators and determine future training requirements.

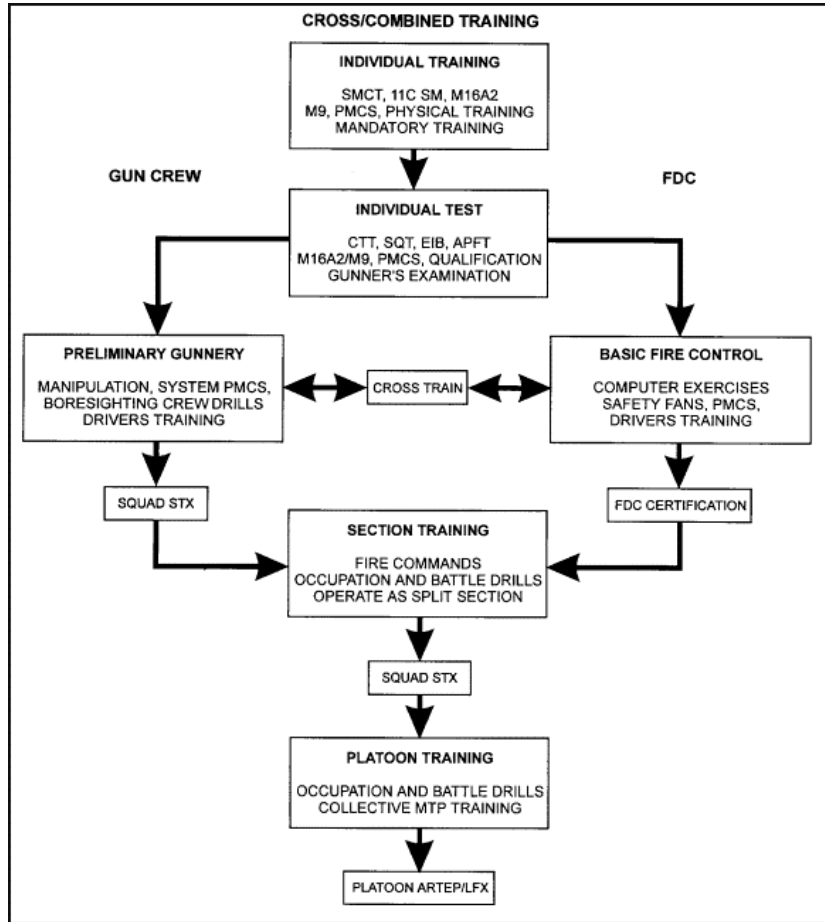

Figure B-1. Integrated training strategy.

(1) *Common tasks.* These tasks are found in STP 7-11-BCHM1-SM, Skill Level 1 and in STP 7-11-BCHM24-SM-TG, Skill Levels 2-4. These manuals contain the common tasks that all soldiers must know, regardless of MOS or duty position, to help them fight, survive, and win in combat. Mastery of these common tasks are a prerequisite for individual training specific to mortars. The communications and land navigation common tasks are vital.

(2) *MOS IIC tasks.* These tasks are found in STP 7-11C14-SM-TG for MOS 11C. This manual contains the individual tasks specific to mortar men. The trainer's guide provides leaders the information to develop the individual portions of a unit training plan. Each IIC task is listed in this guide along with the following:

(a) Training extension courses (TECs). Service schools use TECs to support their expertise directly to units in the field. This is accomplished through lessons in the form of booklets, video slides, audio tapes, videotapes, and electronic information delivery system (EIDS) machines. These lessons focus on individual tasks and are stocked in unit learning centers and the local training support centers. TEC materials provide standardized instruction, which is helpful to soldiers as they move from unit to unit. Preparation time is also saved. However, trainers must ensure the lessons directly and fully support the training objectives.

(b) Army Correspondence Course Program. The ACCP provides printed training courses through the mail to soldiers. It is a valuable program for training the trainer, skill progression, and functional training for a specific specialty, MOS, or duty position. However, planning is needed. Leaders must identify courses that support the goals of the long-range training plan; soldier's enrollment must then be arranged. (ACCP includes the infantry mortar platoon leaders' course.)

c. **Cross Training.** A soldier's individual training tends to focus on his duty position. The assistant computer concentrates on FDC tasks while the squad leader concentrates on mortar mechanical tasks and leading the squad. However, this focus should not exclude other mortar training. Continuous training in duty-specific tasks can become boring to soldiers and deprive them of gaining broad proficiency in their MOS. Casualties (whether in war or in training) can quickly render the mortars ineffective if key personnel are lost. These variables make cross training essential. For example, cross training ensures that a squad leader can assume the duties of a computer and that subordinates are ready to assume the roles of their supervisors.

d. **Collective Training.** Collective training includes squad, section, and platoon drills and exercises.

(1) *Squad training.*

(a) The core of squad training is crew drills. Squad-level mortar tasks are in the infantry MTP. This training can be performed in garrison (using devices or live ammunition). Once these tasks are mastered, an increased challenge is introduced by performing them under different conditions such as urbanized terrain, limited visibility, or NBC. Cross training is accomplished at this level by rotating soldiers among duty positions, such as squad leader and FDC positions, while providing coaching.

(b) The foundation of squad training is sound individual training. If individual proficiency is effectively sustained, new soldiers can be readily integrated into the unit during collective training. They arrive at the unit proficient in specific tasks learned in the training base. These new soldiers learn additional tasks while training with their experienced peers and their squad leaders.

(2) *Section and platoon training.*

(a) The core section and platoon tasks are found in the ARTEP MTP. This training usually consists of an exercise in the field: LFX, STX (either alone or with a rifle company), or FTX as part of the battalion. LFXs may involve subcaliber, sabot, SRTR, or service ammunition. STXs and FTXs may entail dry fire, live fire, or devices, either alone or in combination.

(b) The FIST must be a part of this training. An LFX must never take place without the FISTs normally associated with the battalion. Trainers may wish to integrate these artillerymen into the mortar unit. This teaches the capabilities, limitations, and unique requirements of operating mortars.

(c) Another important area is the mortar's role in overall task force operations. This collective training mainly involves leaders in an FTX. However, mortars must be considered along with other fire support assets when conducting a MAPEX, CFX, TEWT, or CPX.

(3) *Collective training resources.*

(a) Drill books. Crew and battle drills are published in a pocket-sized ARTEP manual called a drill book for each unit organized under a different TOE. (See ARTEP 7-90-DRILL.)

- Battle drills are a specific category of collective tasks performed at squad, section, or platoon level. They are vital to the mortar's success in combat. Battle drills are mostly independent of METT-T and require minimal leader actions to execute. They are usually executed or initiated on a cue such as an enemy action or a simple leader order. Battle drills are standardized throughout the US Army and may not be modified in training. The mortar unit is required to be proficient in all battle drills contained in the drill book. Less critical drills are published in other sources such as training circulars or field manuals.
- Mortar drills are divided into two general areas. The first are those battle drills that previously were termed "crew drills." These focus on the mechanical manipulation of the mortar such as Lay for Small Deflection Change or Remove Misfire. Full proficiency in these tasks is a prerequisite for performing fire support missions. The second area encompasses those battle drills essential to combat survival. These include such tasks as React to Chemical Attack, React to Indirect Fire, or React to Nuclear Attack.

(b) Mission training plan. The MTP is a descriptive ARTEP document for training mortarmen to critical wartime mission proficiency. It gives the mortar platoon or section a clear description of "what" and "how" to train. This is achieved through comprehensive, detailed T&EOs, guidance on training exercises, and other related training management aids. While its focus is on collective training, the MTP also provides matrixes that identify individual tasks, common 11C SM tasks, and MQS tasks. Like the drill book, the mortar MTP applies to platoons or sections organized under a specific TOE. (See ARTEP 7-90-MTP.)

(c) Standards in training commission. STRAC outlines DA requirements for weapons training programs. It provides weapons standards, strategies, and resourcing for the 60-mm, 81-mm, 4.2-inch, and 120-mm mortars for different levels of unit training readiness. It specifies the amount and type of ammunition allocated to each mortar training event, and the annual frequency of that training event. For TRC A and TRC B units, the STRAC specifies that 90 percent of all squad leaders, gunners, and assistant gunners will have passed the mortar gunner's examination within the past six months and FDC personnel will have passed the FDC examination within the past six months (FM 23-91). Also, it states that all mortar sections and platoons will have received a

satisfactory rating IAW ARTEP MTP standards within the past six months.

(d) Battalion-level training model. BLTM is a means to qualify the cost of maintaining training readiness. This cost is expressed in terms of types of training events, their annual frequency, and the equipment miles/hours expended. This model is used to forecast and resource requirements to support the units specified training readiness level. It does not, however, prescribe what training a unit must conduct to maintain this level. Rather, BLTM provides a basis for understanding the trade-off between a unit's training resources and its training strategy developed. This helps leaders program training alternatives to achieve and maintain combat readiness. The frequency of training events under BLTM are reflected in the battalion's long-range training plan. When fully developed, BLTM encompasses and replaces STRAC.

e. **Example Annual Mortar Training Programs.** Figures B-2 and B-3 are examples of battalion-level programs for training mortar units. Figure B-2 depicts a light infantry battalion in CONUS, and Figure B-3 depicts a mechanized infantry battalion in USAREUR. These examples are consistent with current guidance under the STRAC and BLTM.

<p>JANUARY IND WPN QUAL/SUST CREW WPN QUAL/SUST MAINTENANCE SQD/SEC/FDC DRILL (SRTR) PLT/SEC LFX GUNNER'S EXAM FDC CERTIFICATION</p>	<p>FEBRUARY SQD/SEC/FDC DRILL (LITR) PLT FTX CO FTX BN FTX DEPEX MAINTENANCE PLT STX (81-mm ONLY) SUPPORT CO STX</p>	<p>MARCH POST SUPPORT/BN CPX SQD/SEC/FDC DRILL (SRTR) ITEP/CMT CO TEWT</p>
<p>APRIL IND WPN QUAL/SUST CREW WPN SUST MAINTENANCE SQD/SEC/FDC DRILL (LITR) SEC/PLT LFX</p>	<p>MAY SQD DRILL PLT STXs CO FTXs DEPEX BN FTX MAINTENANCE SUPPORT CO FTX</p>	<p>JUNE POST SUPPORT BN CPX CO MAPEX ITEP (EIB) SQD/SEC/FDC DRILL (LITR)</p>
<p>JULY NG & ROTC SUPPORT SQD/SEC/FDC DRILL (SRTR)</p>	<p>AUGUST IND WPN QUAL/SUST CREW WPN QUAL/SUST BN FTX MAINTENANCE</p>	<p>SEPTEMBER SQD DRILL MAINTENANCE CO FTXs BN CPX</p>

	MAINTENANCE FDC EXAM GUNNER'S EXAM SQD/SEC/FDC DRILL (LITR)	BN FTX (EXT EVAL) SQD/SEC/FDC DRILL (SRTR/LITR) PLT STX (81-mm) DEPEX
OCTOBER POST SUPPORT ITEP (CTT) CMT BN TEWT CO MAPEXs CPX (81-mm) SQD/SEC/FDC DRILL (LITR)	NOVEMBER IND WPN QUAL/SUST CREW WPN/SUST DEPEX MAINTENANCE SQD/SEC/FDC DRILL (SRTR) GUNNER'S EXAM FDC CERTIFICATION	DECEMBER POST SUPPORT ITEP CMT SQD/SEC/FDC DRILL (LITR)

Figure B-2. Example training program for light infantry battalion in CONUS.

JANUARY CMT ITEP BN CPX MAINTENANCE SQD DRILLS PLT STX SQD/SEC FDC DRILL (SRTR) IND WPN QUAL/SUST FDC CERTIFICATION	FEBRUARY MAINTENANCE CO FTX BN FTX DEPEX SQD/SEC/FDC DRILL (SABOT) PLT FTX	MARCH MAINTENANCE POST SUPPORT/CO MAPEX BN TEWT ITEP CMT IND WPN QUAL/SUST SQD/SEC/FDC DRILL (SRTR)
APRIL GUNNERY QUAL (MTA) CALFEX (MTA) MAINTENANCE GUNNER'S EXAM LFX (M60, .50-CAL, 4.2-INCH) CALFEX/LFX DRILL (SABOT, 60-mm SUBCAL)	MAY ITEP BN CPX PLT STX MAINTENANCE SQD/SEC BATTLE DRILLS (SRTR/LITR) GUNNER'S EXAM	JUNE CO FTX BN FCX BN DEPEX BN FTX (EXT EVAL [HTA]) MAINTENANCE SQD/SEC/FDC DRILL BN EXT EVAL/LFX
JULY POST SUPPORT ITEP (EIB) BN MAPEX IND WPN QUAL/SUST CMT SQD/SEC/FDC DRILL (SRTR) MAINTENANCE	AUGUST IG INSPECTION ITEP BN CPX MAINTENANCE SQD/SEC/FDC DRILL (SABOT, 60-mm SUBCAL) PLT STX PROGRAM	SEPTEMBER CO FTX MAINTENANCE BN DEPEX BN FTX-(REFORGER) SQD/SEC/FDC DRILL (SRTR) PLT STX

GUNNER'S EXAM		
OCTOBER MAINTENANCE POST SUPPORT CO TEWT ITEP (CTT) CMT SQD/SEC/FDC DRILL	NOVEMBER IND WP QUAL/SUST GUNNERY QUAL (MTA) MAINTENANCE BN CFX SQD/SEC/FDC DRILL (SRTR) FDC EXAM GUNNERY QUAL (.50-CAL, M60) LFX	DECEMBER MAINTENANCE DEPEX POST SUPPORT ITEP IND WPN QUAL/SUST CMT SQD/SEC/FDC DRILL

Figure B-3. Example training program for mechanized infantry battalion in USAREUR.

B-5. TRAINING EVALUATION

Evaluation cannot be separated from effective training. It occurs during the top-down analysis when planners develop the training plan. Planners use various sources of information to assess their unit's individual and collective training status. Evaluation is continuous during training. Soldiers receive feedback through coaching and AARs. Leaders also assess their own training plan and the instructional skills of their subordinate leaders. After training, leaders evaluate by sampling training or reviewing AARs. Much of this evaluation is conducted informally. Formal evaluations occur under the Individual Training and Evaluation Program (ITEP) and the Army Training and Evaluation Program (ARTEP) to assess individual and collective training respectively.

a. Individual Training.

- (1) *Commander's evaluation.* The commander's evaluation is routinely conducted in units. Commanders select and evaluate individual tasks that support their unit mission and contribute to unit proficiency. This may be performed through local tests or assessments of soldier proficiency on crucial MOS tasks or common tasks. The commander's evaluation is based on year-round, constant evaluation by the chain of command. It is supported by the MOS 11C soldier's manuals, trainer's guides, and job books.
- (2) *Common tasks test.* The CTT is a hands-on test that evaluates basic survival and combat tasks. It is taken directly from STP 7-IIBCHM1-SM, STP 7-11BCHM24-SM-TG, and STP 7-IIC14-SM-TG. The CTT gives the unit commander regular, objective feedback on common task proficiency.
- (3) *Gunner's examination.* The gunner's examination is a continuation of the mortar-based drills in which a mortarman's proficiency as a gunner is

established. The examination is contained in Chapter 9 of this manual. It includes tasks, conditions, standards, and administrative procedures. It focuses on the individual qualification of the soldier in the role of a gunner. However, the gunner's success also depends on the collective performance of his assistants. Within these limitations, evaluators should try to standardize the examination. STRAC specify that the squad leader, gunner, and assistant gunner should pass the gunner's exam semiannually. All gunners should have a current qualification before an LFX (whether using service or subcaliber ammunition).

(4) *FDC certification.* This provides commanders a means to verify that their FDC mortarmen have the knowledge and skills for their positions: squad leader, FDC computer, section sergeant, platoon sergeant, and platoon leader. Certification helps ensure that ammunition is widely expended and that training is conducted safely and effectively. Mortarmen are certified when they receive a passing score on the two-part examination (90 percent on the written and 70 percent on the hands-on). (See FM 23-91 for FDC certification.)

b. Collective Training.

(1) *Army Training and Evaluation Program.* The aim of collective training is to provide units the skills required to perform unit-level tasks. The ARTEP is the overall program for this collective training. It prescribes the collective tasks that a unit must successfully perform to accomplish its mission and to survive in combat. These tasks include conditions and performance standards, and they are located in MTPs and drill books.

(2) *External evaluation.* The commander formally determines the status of his collective training through external evaluation. The external evaluation gives the commander an objective appraisal of this status by using mortar expertise found outside the normal chain of command. The external evaluation is not a test in which a unit passes or fails; it is a diagnostic tool for identifying training strengths and weaknesses. It must be emphasized that an external evaluation is not a specific training event but a means to evaluate a training event. Mortar units undergo external evaluations during an LFX, FTX, or a combination thereof. The unit may be evaluated alone, as part of its parent unit, or with other mortar units. The MTP provides guidance on planning, preparing, and conducting an external evaluation.

(3) *Evaluation of forward observer.* The mortars can be no more effective than the FOs. It is critical that FIST FOs are present and evaluated during an externally evaluated mortar LFX. If an FO fails to meet his performance standards, the mortars should not be penalized. However, only as a last resort should the fire mission be deleted from the evaluation.

The mortars should be given the opportunity to successfully complete the fire mission. This can be accomplished in the following ways:

- (a) Start the fire mission over. Although ammunition constraints during live-fire may not permit this, tasks can be repeated using devices or, less preferably, dry fire.
- (b) Correct the call for fire or correction. The mortars should not have to use wrong firing data if the FO has made an incorrect call for fire or correction. This also wastes valuable training ammunition. The FO evaluator at the observation point can change the call for fire or correction to reflect proper procedures.

GLOSSARY

AAR	after-action review
AC	Active Component; aiming circle
ACCP	Army Correspondence Course Program
amp	ampere
ANCOG	Advanced Noncommissioned Officer's Course
APFT	Army Physical Fitness Test
AR	Army regulation
ARTEP	Army Training and Evaluation Program
ATTN	attention
BAD	blast attenuator device
BDU	battle dress uniform
BFV	Bradley fighting vehicle
BLTM	battalion-level training model
BNCOC	Basic Noncommissioned Officer's Course
cm	centimeter
CMF	career management field
CONUS	continental United States
CS	combat support
CSS	combat service support
CTT	common task test
D	delay; drop-fire
DA	Department of the Army
dc	direct current
DLY	delay (M734 multioption fuze)
DODAC	Department of Defense ammunition code
DS	direct support
EIB	Expert Infantryman Badge

EIDS	electronic information delivery system
EOD	explosive ordnance disposal
F	Fahrenheit; fire
FDC	fire direction center
FFE	fire for effect
FIST	fire support team
FM	field manual
FO	forward observer
FSE	fire support element
FT	firing table
FTX	field training exercise
GFS	graphical firing scale
GM	grid-magnetic angle
gpm	gallons per minute
GT	gun-target
GTA	graphics training aid
HE	high explosive
HHC	headquarters and headquarters company
HQ	headquarters
hr	hour
IAW	in accordance with
IET	initial entry training
ILLUM	illumination
IM	impact (M734 multioption fuze)
IMLC	Infantry Mortar Leader Course
IMP	impact
IOAC	Infantry Officer's Advance Course
IOBC	Infantry Officer's Basic Course
ITEP	Individual Training and Evaluation Program
kg	kilogram

LARS	left add, right subtract
lb	pound
LFX	live-fire exercise
MAPEX	map exercise
MBC	mortar ballistic computer
METL	mission-essential task list
METT-T	mission, enemy, terrain, troops and time available
MILES	multiple integrated laser engagement system
mm	millimeter
MOS	military occupational specialty
mph	miles per hour
mps	meters per second
MQS	military qualification standards
MT	mechanical time
MTP	mission training plan
MTSQ	mechanical time superquick
N	North
NA	not applicable
NATO	North Atlantic Treaty Organization
NBC	nuclear, biological, chemical
NCO	noncommissioned officer
NCOES	Noncommissioned Officer Education System
NDI	nondevelopmental item
NSB	near-surface burst
OES	Officer Education System
OIC	officer in charge
OP	observation post
OPFOR	opposing force
OSUT	one station unit training
OT	observer-target

Pam	Pamphlet
PCC	Pre-Command Course
PD	point-detonating
PMCS	preventive maintenance checks and services
PROX	proximity
prx	proximity (M734 multioption fuze)
psi	per square inch
PWP	plasticized white phosphorus
QSTAG	quadripartite standardization agreement
RC	Reserve Component
RDX	cyclonite
RP	red phosphorus; release point
RPO	radiation protection officer
S	South; safe
S3	operations and training officer
SM	soldier's manual
SMCT	soldier's manual of common tasks
SOP	standing operating procedure
SQ	superquick
SRTR	short-range training round
STANAG	Standardization Agreement
STRAC	Standards in Training Commission
STX	situational training exercise
T&EO	training and evaluation outline
TB	technical bulletin
TEC	training extension course
TEWT	tactical exercise without troops
TM	technical manual
TOE	table of organization and equipment
TNT	trinitrotoluene
TP	training practice

TRADOC	US Army Training and Doctrine Command
TRC	type requisition code
USAIS	US Army Infantry School
USAREUR	United States Army in Europe
US	United States
VT	variable time
WP	white phosphorus
w/o	without

REFERENCES

Documents Needed

These documents must be available to the intended users of this publication.

DA Form 2188-R	Data Sheet. March 1991
DA Form 2399	Computer's Record. December 1991
DA Form 2408-4	Weapon Record Data. 1 January 1979
DA Form 5964-R	Mortars, Ground-Mounted, Carrier-Mounted, Support. September 1990
FM 23-91	Mortar Gunnery. 6 December 1991
FT 4.2-H-2	Mortar, 4.2-Inch, M30 Carrier, 107-mm Mortar: M106A1 and M106; Firing Cartridge, HE, M329A1; Cartridge, Smoke, WP, M328A1; Cartridge, Tactical CS, XM630 and Cartridge, Illuminating: M335A1 and M335A2. 30 August 1968
FT 4.2-K-2	Mortar, 4.2-Inch, M30, and Firing Cartridge, HE, M329A2. 30 June 1984
FT 60-L-5	Mortar, 60-mm: M19 and M2 Firing Cartridge, HE, M49A4 Cartridge, TP, M50A3 Cartridge, Smoke, WP, M302A1 and M302A2 Cartridge, Illuminating, M83A1. 15 March 1974
FT 60-P-1	Mortar, 60-mm: M224, Firing Cartridge, HE, M720; Cartridge, HE, M49A4; Cartridge, HE, XM888; Cartridge, TP, M50A3; Cartridge, WP, M302A1 and Cartridge, Illuminating, M83A3. 22 March 1980
FT 60-Q-1	Firing Table for Mortar, 4.2-Inch, M30 with Mortar, 60-mm, M31, Subcaliber Assembly Firing Cartridge, HE, M49A4, Cartridge, TP, M50A3, Cartridge WP, M302A1, Cartridge, Illum, M83A3. 30 April 1987

FT 81-AI-3	Mortar, 81-mm: M29A1 and M29; Mortar, 81-mm, Self-Propelled: M125A1 and M125; Carrier, 81-mm Mortar: Tracked, XM755; Firing Cartridge, HE: M374A2 and M374; Cartridge, WP, M375A2 and M375; Cartridge, Illuminating: M301A3; Cartridge, Training: M68 and Training Device, M1. 22 March 1973
FT 81-AQ-1	Firing Table for Mortar, 81-mm: M29A1 and M29; Mortar, 81-mm, Self-Propelled: M125A1 and M125; Carrier, 81-mm Mortar: Tracked, M755 and Firing Cartridge, HE, M374A3. 31 August 1981
FT 81-AR-1	Mortar, 81-mm, M252, Firing Cartridge, HE, M821, Cartridge, HE, M889, Cartridge, RP, M819. 31 October 1986
TM 9-2350-261-10	Operator's Manual for Carrier, Personnel, Full-Track: Armored, M113A2; Carrier, Command Post, Light: Tracked, M577A2; Carrier, Mortar: 107-mm, M30; Self-Propelled: M106A2 CArrier, Mortar, 81-mm, M29A1; Self-Propelled, M125A2 Carrier, Smoke Generator, Full Tracked M1059. 12 July 1990

Readings Recommended

These readings contain supplemental information.

AR 385-63	Policies and Procedures for Firing Ammunition for Training, Target Practice, and Combat. 15 October 1983
ARTEP 7-90-Drill	Drills for the Infantry Mortar Platoon, Section, and Squad. 14 February 1990.
ARTEP 7-90-MTP	Mission Training Plan for the Infantry Mortar Platoon, Section, and Squad. 10 August 1989
DA Pam 25-30	Consolidated Index of Army Publications and Blank Forms. 1 October 1999
DA Pam 350-38	Standards in Weapons Training. 3 July 1997
DA Pam 351-20	Army Correspondence Course Program Catalog. 1 October 1998
DA Pam 738-750	Functional Users Manual for the Army Maintenance Management System (TAMMS). 1 August 1994
FM 5-103	Survivability. 10 June 1985
FM 6-30	Tactics, Techniques, and Procedures for Observed Fire. 16 July 1991.

FM 7-10	The Infantry Rifle Company. 14 December 1990
FM 7-20	The Infantry Battalion. 6 April 1992
FM 7-90	Tactical Employment of Mortars. 9 October 1992
FM 9-207	Operation and Maintenance of Ordnance Materiel in Cold Weather. 20 March 1998
FM 20-3	Camouflage. 14 November 1990
FM 21-11	First Aid for Soldiers. 27 October 1988
FM 21-26	Map Reading and Land Navigation. 7 May 1993
FM 24-1	Signal Support in the AirLand Battle. 15 October 1990
FM 24-18	Tactical Single-Channel Radio Communications Techniques. 30 September 1987
FM 25-4	How to Conduct Training Exercises. 10 September 1984
FM 25-100	Training the Force. 15 November 1988
FM 25-101	Battle Focused Training. 30 September 1990
FM 71-2	The Tank and Mechanized Infantry Battalion Task Force. 27 September 1988
FM 101-5-1	Operational Terms and Graphics. 30 September 1997
STP 7-11C14-SM-TG	Soldier's Manual, Skill Levels 1/2/3/4 and Trainer's Guide, MOS 11C, Indirect Fire Infantryman. 16 August 1994
TB 9-1300-256	Ammunition: National Stock Numbers and Department of Defense Codes. 30 June 1999
TB 34-9-93	NATO Design Mark. 28 August 1961
TM 9-1010-223-10	Operator's Manual for Lightweight Company Mortar, 60-mm: M224. 15 September 1998
TM 9-1015-200-10	Operator's Manual for Mortar, 81-mm, M29A1. 23 October 1985
TM 9-1015-200-20&P	Organizational Maintenance Manual Including Repair Parts and Special Tools List for Mortar, 81-mm, M29A1. 25 October 1985
TM 9-1015-200-30&P	Direct Support Maintenance Manual Including Repair Parts and Special Tools List for 81-mm Mortar, M29A1. 22 October 1985
TM 9-1015-215-10	Operator's Manual for 4.2-Inch Mortar, M30. 15 December 1993
TM 9-1015-215-23&P	Unit Direct Support Maintenance Manual With Repair Parts and Special Tools List (Including Depot Maintenance Repair Parts and Special Tools) for Mortar 4.2-Inch: M30 (Barrel M30 on Mount M24A1) and Trainer, Subcaliber, 60-mm: M31. 8 December 1993
TM 9-1015-250-10	Operator's Manual for Mortar 120-mm: Towed M120 and Mortar, 120mm: Carrier-Mounted M121. 19 August 1996
TM 9-1290-262-24&P	Unit, Direct Support, and General Support Maintenance Manual (Including Repair Parts and Special Tools List) for Aiming Circle,

M2A2 W/E. 22 September 1994

TM 9-1290-333-15 Operator's, Organizational, Direct Support, General Support and Depot Maintenance (Including Repair Parts and Special Tools List): Compass, Magnetic, Unmounted: M2. 7 November 1963

TM 9-1300-200 Ammunition, General. 3 October 1969

TM 9-1315-249-12&P Operator's and Unit Maintenance Manual (Including Repair Parts and Special Tools List) for 81-mm Mortar Training Device, 81-mm Sabot (Inert) M1 and 22-mm Subcaliber Practice Cartridges M744, M745, M746, and M747. 1 September 1990

TM 43-0001-28 Army Ammunition Data Sheets for Artillery Ammunition: Guns, Howitzers, Mortars, Recoilless Rifles, Grenade Launchers, and Artillery Fuzes. 28 April 1994