

## APPENDIX B

# GUIDELINES FOR SETTING A NATIONAL CORS MONUMENT

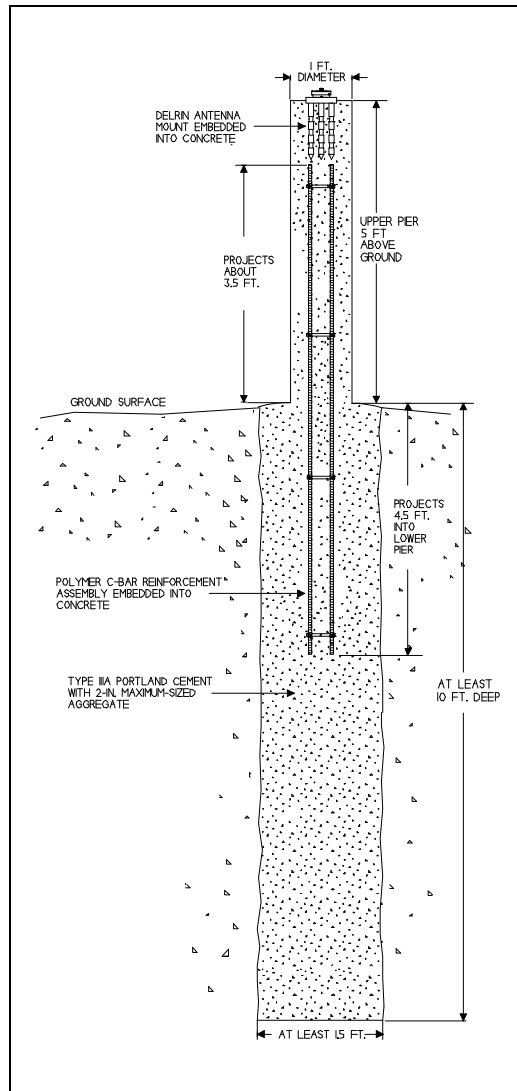

Submitted by  
Orland W. Murray  
Member  
Process Action Team 20

# **GUIDELINES FOR SETTING A NATIONAL CORS MONUMENT**

## **INTRODUCTION**

This document serves as an illustrated guide for the construction of a monument for a National CORS (Continuously Operating Reference Station). The monument consists of a massive concrete pier, a polymer Delrin antenna mount, and a polymer C-Bar reinforcement assembly (Figure 1). The materials, dimensions, and procedures for the construction of the monument conform to the recommendations of Process Action Team 20 of the National Geodetic Survey (NGS).

Construction involves purchasing materials, scheduling services, and assembling components. Stock materials must be purchased for the antenna mount, the C-Bar reinforcement, and an aboveground form to support the semifluid concrete. Services must be scheduled to machine certain stock materials for the antenna mount, to check for underground pipes and cables at the site, to drill the large-diameter hole for the below ground section of the pier, to deliver the concrete, and to rent a vibrator to consolidate the semifluid concrete. Modified and stock materials must be assembled for the antenna mount, the C-Bar reinforcement, and the aboveground form.

FIGURE 1: NATIONAL CORS MONUMENT

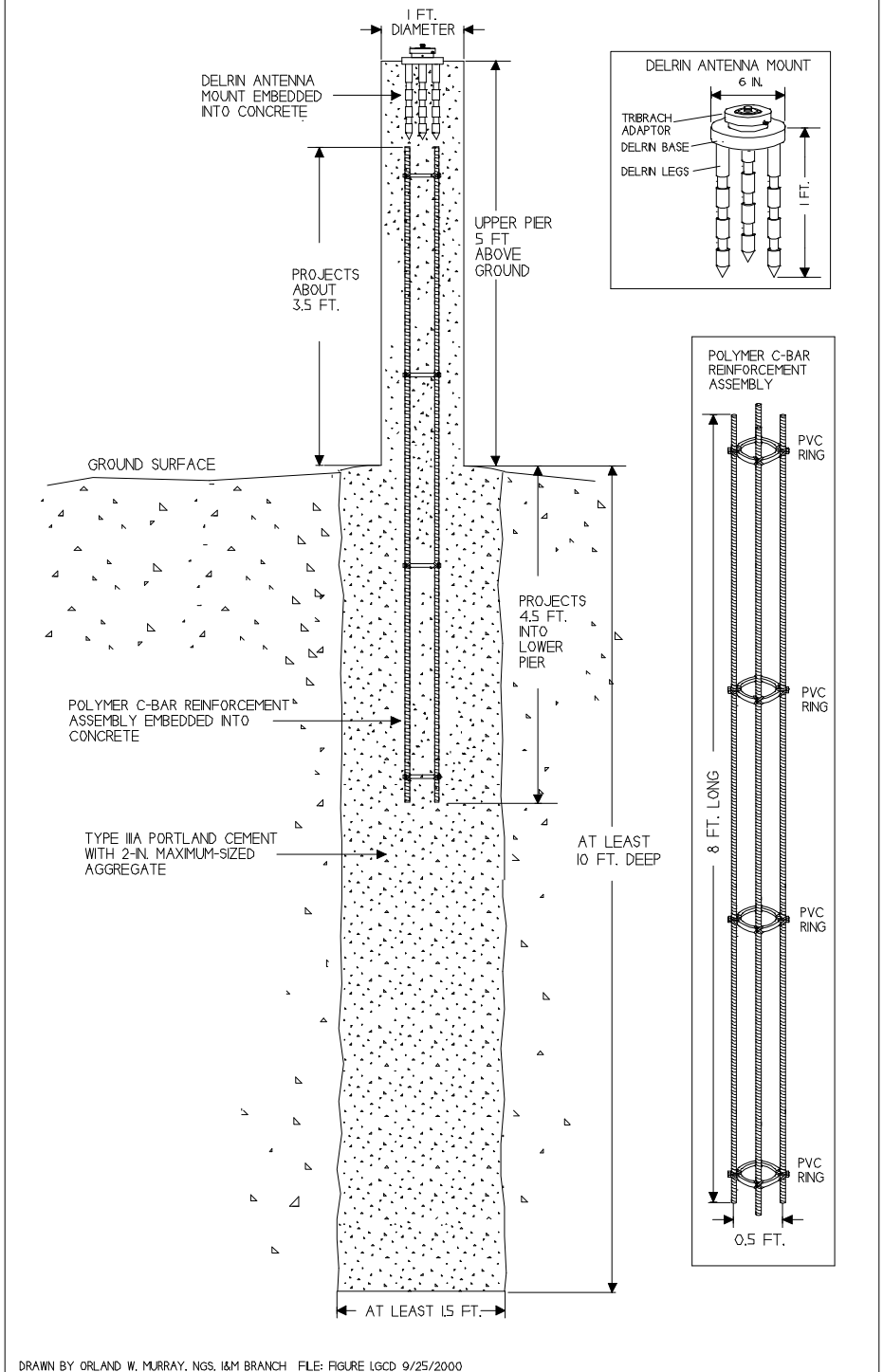

Figure 1 - National CORS Monument

## ANTENNA MOUNT

Design goals for the antenna mount are to minimize the amount of metal near the antenna that may cause radiometric interference, to minimize the empty space under the antenna that may result in a multipath resonance cavity, and to fix the antenna firmly to a repeatable position that can accept slight adjustments in level and orientation.

The antenna mount consists of a standard rotating tribrach adaptor attached by modified stainless steel bolts to a machined Delrin base and legs (Figure 2).

Materials:

- 1 Standard rotating tribrach adaptor
- 1 10-32 UNF-2A, 1-1/2-in.-long stainless steel socket head cap screws
- 3 5/16-18 UNC-2A, 1-1/2-in.-long stainless steel hexagon bolts
- 1 6-1/2-in.-diameter roughly cut by 1-in.-thick Delrin plate
- 3 1-in.-diameter by 12-in.-long Delrin rod stock

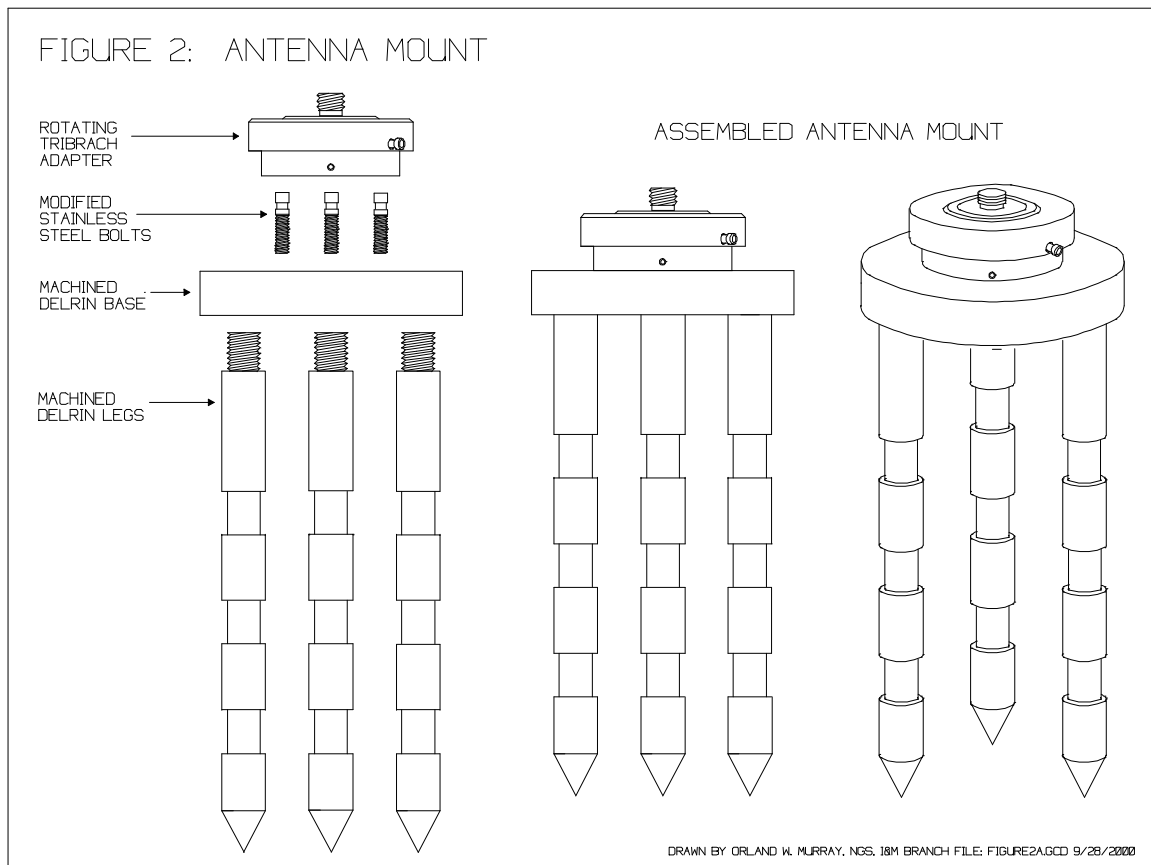

Figure 2 - Antenna Mount

Standard rotating tribrach adaptors are available from most surveying supply companies and original manufacturers. This precision-made piece of equipment normally clamps atop a standard tribrach that is used for centering and leveling a target or GPS antenna (Figure 3).

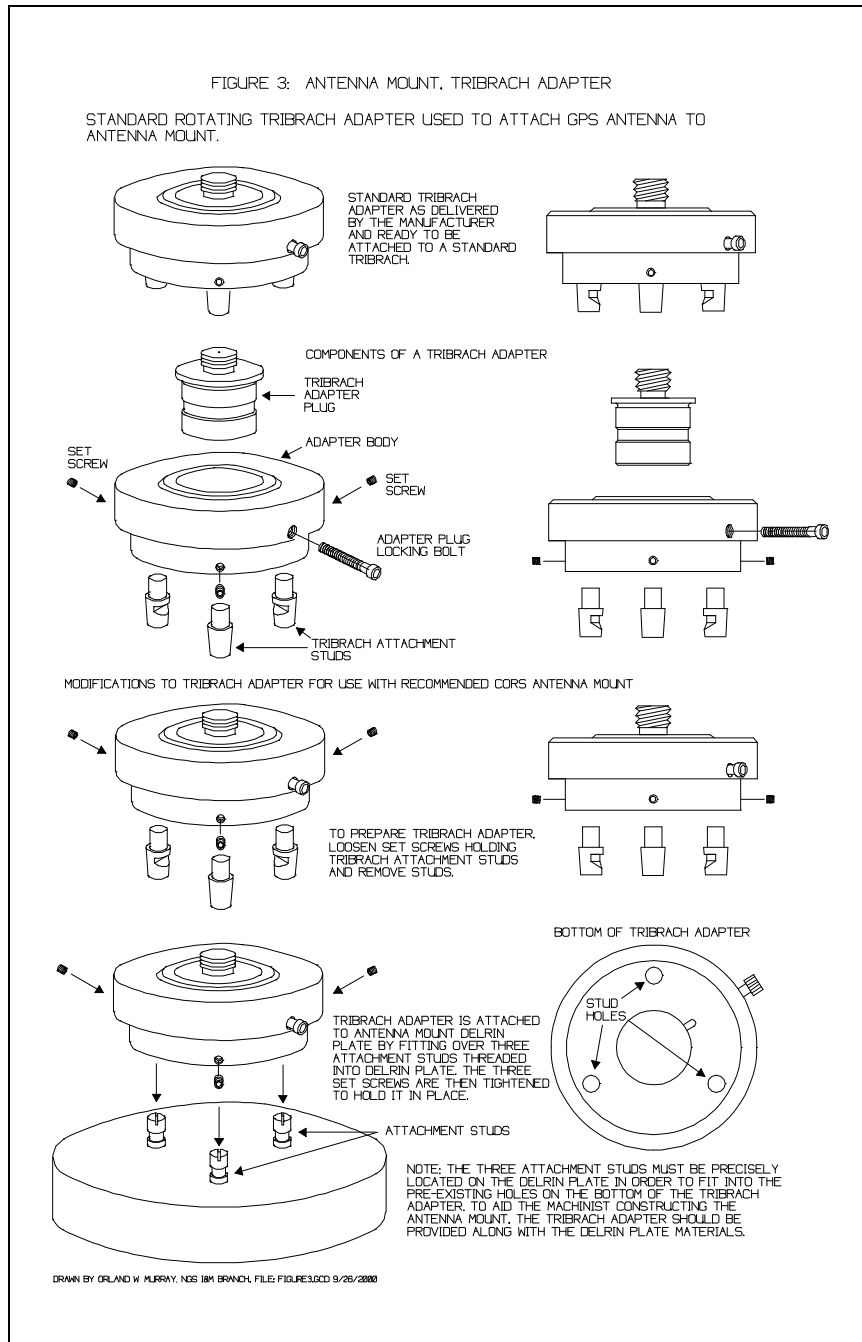

Figure 3 - Antenna Mount, Tribrach Adapter

The 5/8-11 brass tribrach adaptor plug may be rotated to orient a target or GPS antenna, and it is locked to a repeatable position by a 10-32 by 1-1/2-in.-long thumb screw. The thumb screw may be replaced by a 10-32 by 1-1/2-in.-long stainless steel socket head cap screw for easier access in confined space.

The brass feet or studs that allow the tribrach adaptor to be clamped atop a tribrach are secured by set screws. Loosen the set screws, and replace the brass tribrach attachment studs with modified stainless steel bolts.

The three stainless steel 5/16-18 UNC-2A, 1-1/2-in.-long hexagon bolts and the stainless steel 10-32 UNF-2A, 1-1/2-in.-long socket head cap screw are readily available from a variety of fastener supply houses. Threads are specified by the nominal size, number of threads per in., thread series, and class of tolerance. Unified National Coarse thread series are commonly used in fastening; Class 2A and 2B tolerances are commonly used for general-purpose mating parts. Class "A" tolerance on a screw is somewhat closer than class "B" tolerance on threaded holes.

The services of a machine shop are needed to modify the three stainless steel bolts (Figure 4). The heads of the bolts are removed, a 0.160-in.-long notch along the shaft is reduced to 0.250-in. diameter to allow positive locking of the set screws to the harder stainless steel, and a standard Fillister head slot is cut to accept a screwdriver. The bolts allow slight adjustments to the level of the tribrach adaptor.

Delrin is a registered trademark of Dupont, Wilmington, Delaware. Delrin acetal resin material used for the antenna mounting plate and the legs is a UV-resistant, high viscosity type (127UV BK601), and may be obtained from many plastic products companies.

The services of a machine shop are needed to modify the Delrin plate and legs (Figures 5-7).

The initial modification to the flat plate is to smooth the roughly cut outer edge in a lathe to 6-in. diameter (Figure 5, top). Holes must be drilled and tapped into the top of the Delrin plate to accept the modified bolts that secure the tribrach adaptor (Figure 5, bottom). Threads are 5/16-18 UNC-2B, 0.875 in. deep. Because these holes for the bolts must align exactly with the holes in the base of the tribrach adaptor, the machinist should be allowed to make his own measurements for their location directly from the tribrach adaptor. Finally, holes must be drilled and tapped into the bottom of the Delrin plate to accept the Delrin legs (Figure 6). Threads are 3/4-10 UNC-2B, 0.875 in. deep. Because straight threads fail to form a leak-proof seal, none of the holes is through-going.

The first 7/8 in. of each Delrin leg is reduced in diameter to accept 3/4-10 UNC-2A threads to mate with the holes in the Delrin plate (Figure 7). The final 1 in. of each Delrin leg receives a tapered point to ease the job of pushing the assembled antenna mount into the semifluid concrete pier. Finally, three 1-in.-long notches along the shaft are reduced in diameter to 0.750 in. to allow positive grip of the Delrin legs to the concrete pier.

FIGURE 4: ANTENNA MOUNT, ATTACHMENT STUDS

THREE 5/16-18 UNC-2A, 1-1/2-IN-LONG STAINLESS STEEL BOLTS, THE BOLTS ARE MODIFIED TO CREATE THE ATTACHMENT STUDS FOR MOUNTING THE TRIBRACH ADAPTER TO THE DELRIN BASE PLATE.

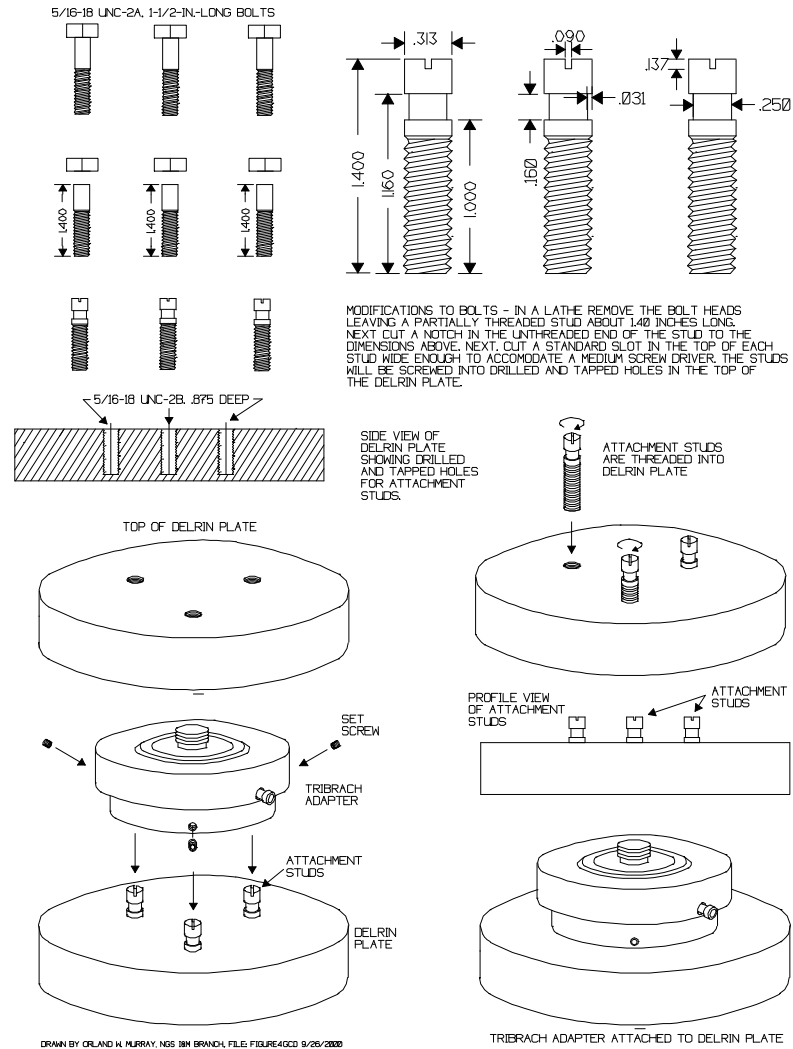
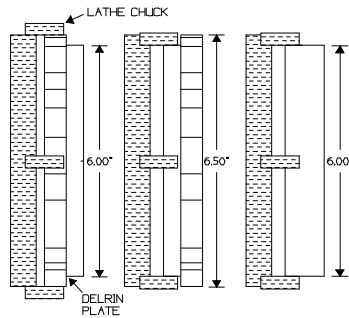
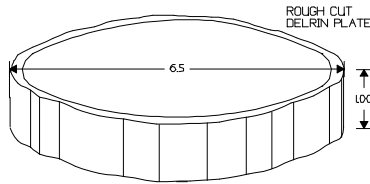

Figure 4 - Antenna Mount, Attachment Studs

FIGURE 5: ANTENNA MOUNT, DELRIN PLATE, PART 1

A 1-IN-THICK PIECE OF DELRIN POLYMER PLATE ROUGHLY CUT TO A DIAMETER OF 6-1/2 IN. THIS PLATE SUPPORTS THE TRIBRACH ADAPTER FOR THE GPS ANTENNA AND PROVIDES THE ATTACHMENT POINT TO THE CORS MONUMENT PIER.



MODIFICATION #1 - CHUCK THE ROUGH-CUT DELRIN PLATE IN A LATHE AND TURN AS MUCH OFF THE OUTER EDGE AS POSSIBLE TO A DIAMETER OF ABOUT 6.00 IN. FLIP THE PLATE IN THE LATHE CHUCK AND TURN THE REMAINDER OF THE EDGE TO 6.00 IN. WHILE THE PLATE IS STILL IN THE LATHE, MARK THE CENTER OF THE PLATE.

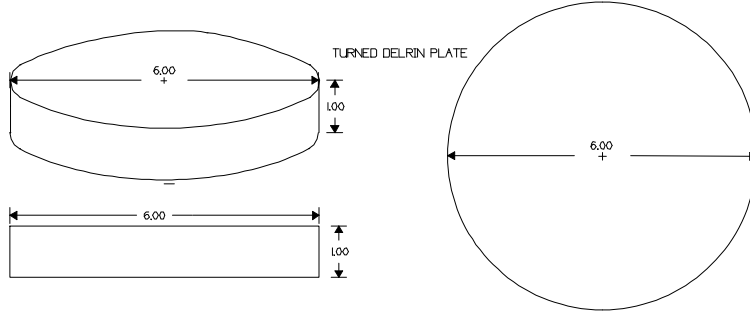

MODIFICATION #2 - LOCATING, DRILLING AND TAPPING ATTACHMENT STUD HOLES. THIS IS THE MOST PRECISE WORK REQUIRED IN THE CONSTRUCTION OF THE ANTENNA MOUNT BECAUSE THE ATTACHMENT STUDS MUST EXACTLY FIT THE PREDRILLED HOLES IN THE BOTTOM OF THE TRIBRACH ADAPTER. THE MEASUREMENTS DEPICTED IN THIS DRAWING ARE AS CLOSE AS POSSIBLE WITH A HAND RULE. MAKE SURE THE MACHINIST HAS THE TRIBRACH ADAPTER SO HE CAN MAKE HIS OWN MEASUREMENTS. THE HOLES SHOULD BE DRILLED AND TAPPED TO ACCOMMODATE THE ATTACHMENT STUDS DESCRIBED IN FIGURE 4. THE HOLES ARE 5/16-IN. NOMINAL DIAMETER, 18 THREADS PER IN. UNIFIED NATIONAL COURSE SERIES, CLASS 2 TOLERANCE INTERNAL THREADS (5/16-18, UNC-2B).

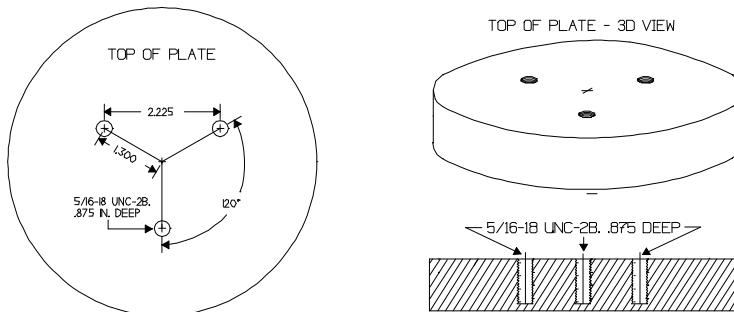

DRAWN BY ORLAND K. MURRAY, NGS (SM BRANCH FILE: FIGURE5.DWG) 9/26/2008

Figure 5 - Antenna Mount, Delrin Plate, Part 1



FIGURE 6: ANTENNA MOUNT, DELRIN PLATE, PART 2

MODIFICATION #3 - LOCATING, DRILLING, AND TAPPING OF HOLES FOR ANTENNA MOUNT DELRIN SUPPORT LEGS. THE LOCATION OF THE HOLES FOR THE LEGS DOES NOT HAVE TO BE AS PRECISE AS FOR THE TRIBRACH ADAPTER ATTACHMENT STUDS. LOCATION AND SIZE ARE SHOWN ON THE DRAWINGS BELOW. THE HOLES SHOULD BE DRILLED AND TAPPED FOR 3/4-IN NOMINAL DIAMETER, 10 THREADS PER IN. UNIFIED NATIONAL COURSE SERIES, CLASS 2 TOLERANCE INTERNAL THREADS.

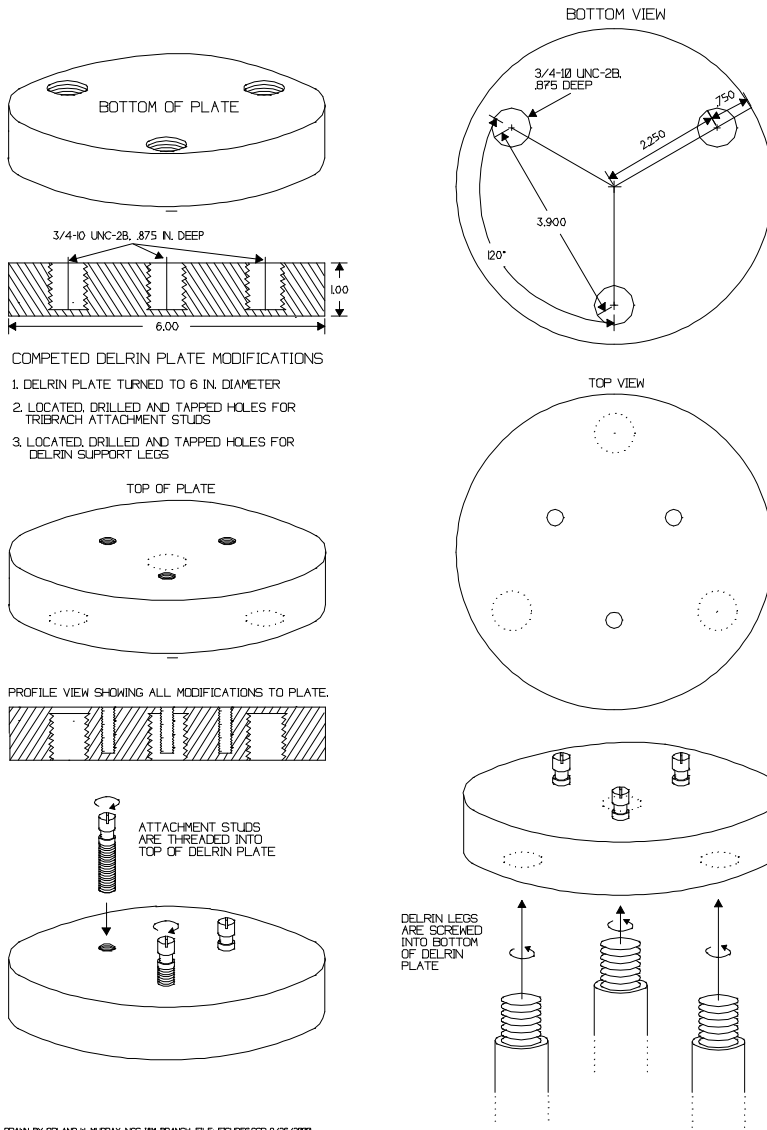

Figure 6 - Antenna Mount, Delrin Plate, Part 2

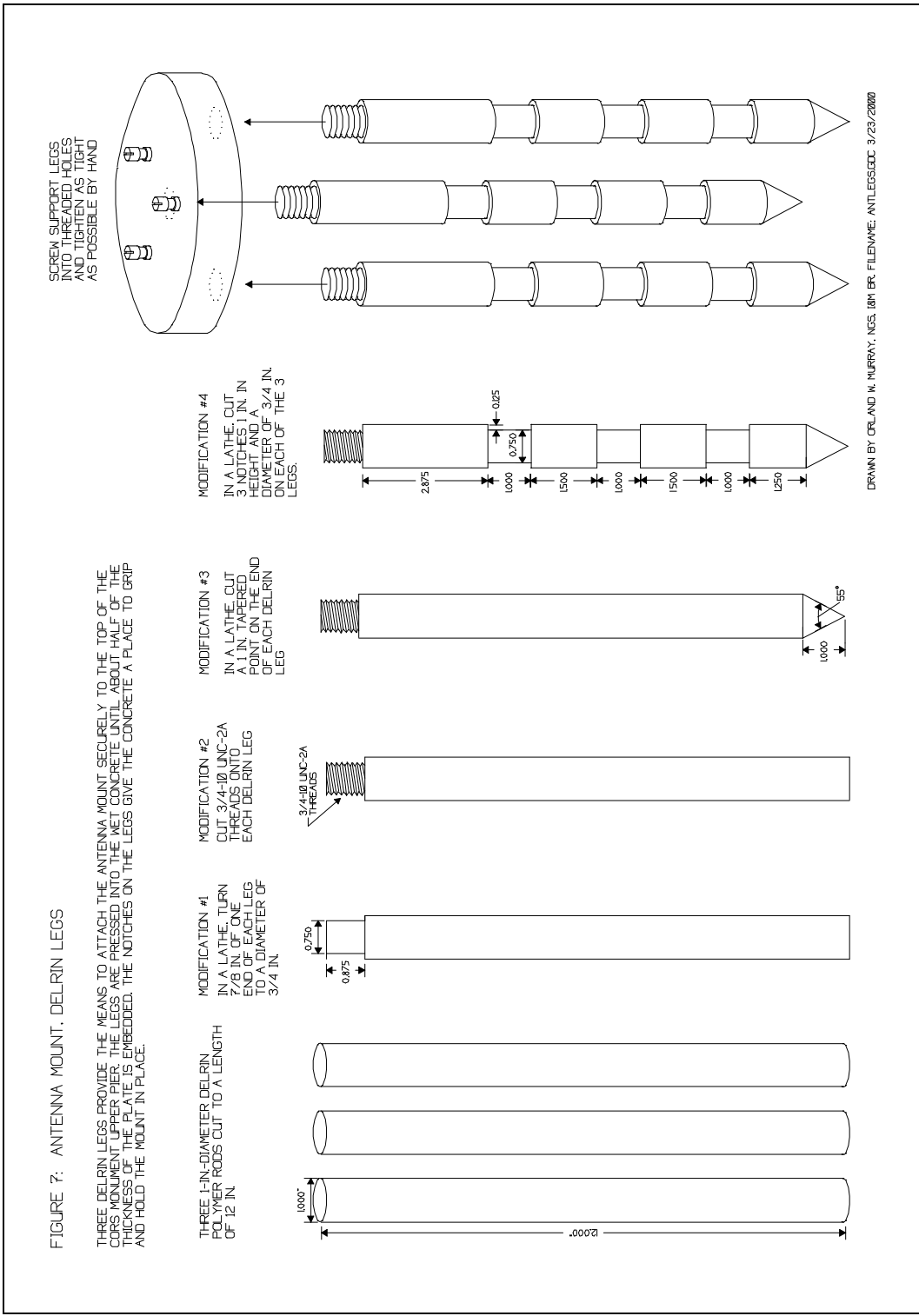

Figure 7 - Antenna Mount, Delrin Legs

## **C-BAR REINFORCEMENT ASSEMBLY**

Design goals for the C-Bar reinforcement assembly are to minimize the amount of metal near the antenna that may cause radiometric interference and to provide shear strength to the narrow aboveground section of the concrete pier. Reinforcement also helps to control cracking from tensile stress due to drying shrinkage of concrete in restrained conditions, such as from subgrade friction near the ground surface.

The C-Bar assembly consists of four fiber-reinforced polymer (FRP) reinforcing bars that are separated by PVC pipe rings (Figure 8). The PVC rings are merely an economical means to maintain even spacing among the reinforcing bars.

Materials:

- 4 5/8-in.-diameter by 8-ft.-long C-Bar reinforcing rods
- 4 5-1/2-in. inside-diameter by 1/2-in.-tall PVC pipe rings
- 32 Plastic cable ties (medium duty, 3/8-in.-wide by 14-1/2-in.-long)

C-Bar is a registered trademark of Marshall Industries Composites, Inc., Lima, Ohio. C-Bar or similar fiber-reinforced polymer (FRP) composite reinforcing bars are available from some suppliers of steel and concrete building materials.

If the site requires that a shallow pier be set due to near-surface bedrock, C-Bar may be shortened, but the cuts must be sealed with EPDM Rubber Spray Coating. The glass fibers will deteriorate in the alkalinity of concrete if not protected by the surrounding resin matrix.

**WARNING: ALWAYS WEAR GLOVES WHEN HANDLING C-BAR RODS. THE GLASS FIBERS WILL PENETRATE SKIN!**

With a saw, cut four 1/2-in.-long rings from a length of standard 5-1/2-in. diameter PVC pipe. Distribute the cylinder of PVC rings along the length of the C-Bar rods, and secure them with plastic cable ties, forming a long rectangular cage. Figure 8 details one method of building the reinforcement assembly.

FIGURE 8: C-BAR REINFORCEMENT ASSEMBLY

FOUR 5/8-IN. DIAMETER BY 8-FT.-LONG C-BAR RODS ARRANGED IN A SQUARE PATTERN USING FOUR 5-1/2-IN.-DIAMETER BY 1/2-IN.-HIGH PVC RINGS AND 32 PLASTIC CABLE TIES, 14-1/2-IN.-LONG. THE C-BAR RODS PROVIDE SHEAR STRENGTH AT THE GROUND SURFACE WHERE THE DIAMETER OF THE MONUMENT CHANGES.

PLACE A PVC RING 4 TO 6 IN. FROM THE END OF A C-BAR ROD. LOOP A CABLE TIE THROUGH THE RING AND OUT AROUND THE ROD AND INTO THE OTHER END OF THE TIE, LEAVING THE TIE SLIGHTLY LOOSE. PLACE ANOTHER CABLE TIE THROUGH THE RING AND LOOP IT AROUND SO THAT IT FORMS AN "X" WITH THE OTHER TIE. TIGHTEN BOTH TIES, WHICH SHOULD CAUSE THE PVC RING TO BE PERPENDICULAR TO THE ROD. DO THE SAME FOR THE OTHER THREE RODS, POSITIONING THEM IN A SQUARE PATTERN AROUND THE RING. LOCATE ANOTHER PVC RING AT THE OTHER END OF THE RODS. FINALLY DO THE TWO MIDDLE RINGS.

PVC RINGS

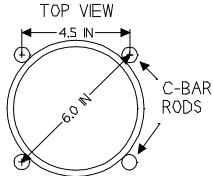
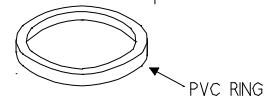
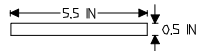

LOCATION OF C-BAR RODS ON OUTSIDE OF RING

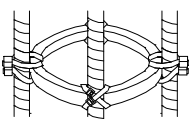

LOCATION OF CABLE TIES

PLASTIC CABLE TIE

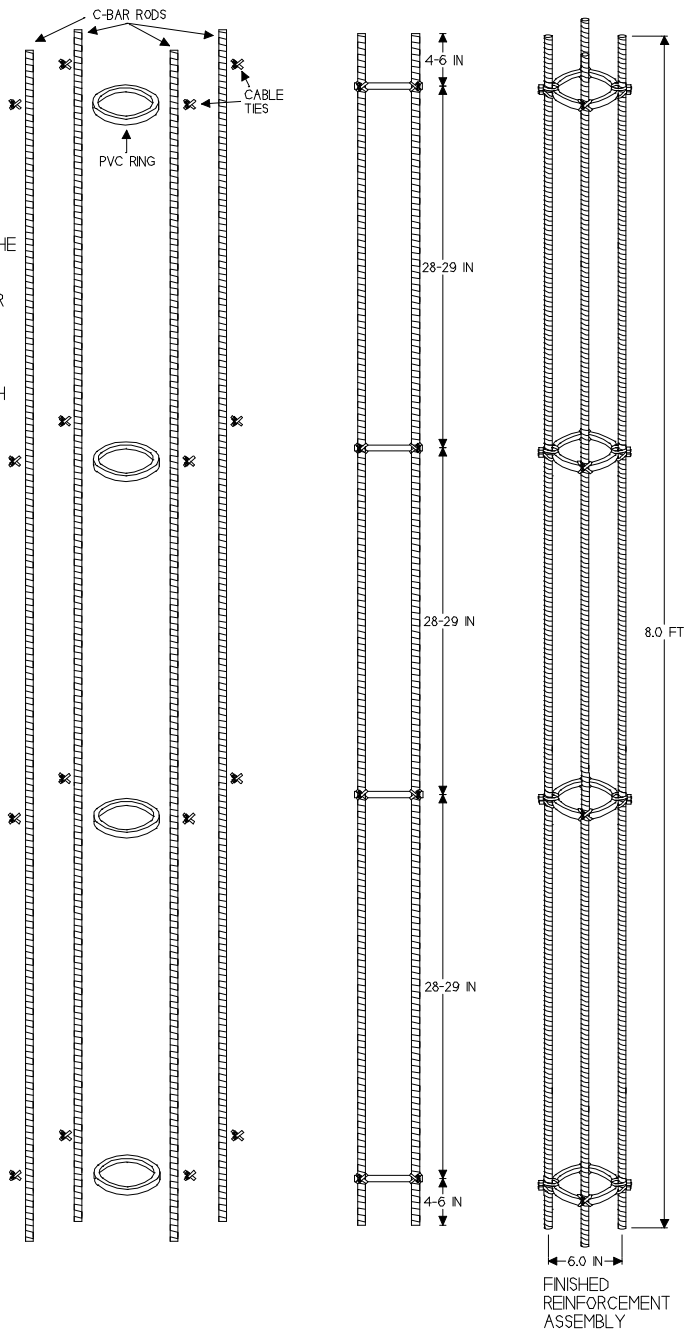

DRAWN BY ORLAND W. MURRAY, NGS, FILE: FIGURE8.GCD, 9/26/2000

Figure 8 - C-Bar Reinforcement Assembly

## SONOTUBE FORM AND SUPPORT BRACES

A Sonotube form supports the aboveground pier of semifluid concrete during hydration (curing). Triangular brackets and wooden support braces at the top and bottom of the tube provide the means to raise, lower, and plumb the vertical form.

### Materials:

- 1 12-in.-diameter by 5-ft.-long Sonotube or similar paperboard cylinder
- 1 Short piece of Sonotube, 1 ft.-tall or less
- 3 8-ft.-long 2 by 4 lumber
- box 1-in.-long drywall screws
- box 3-1/2-in.-long drywall screws

### Tools:

- 1 Cordless drill
- 1 Handsaw or power saw
- 1 Tape measure
- 1 Carpenter's square
- 1 Protractor

Sonotube is a registered trademark of Sonoco, Hartsville, South Carolina. Materials are available at local building supply centers.

Sonotube or similar paperboard construction cylinders are available in 12-ft.-long stock. Measure, square, and cut the 12-in.-diameter Sonotube into a 5-ft.-long piece and a 1-ft.-long piece (Figure 9, upper left). The short piece is used to indent the wet concrete at the ground surface to aid the correct placement of the awkward braced form.

For the support brackets, cut six 30-in.-long pieces of 2 by 4 lumber (Figure 9, upper right). Cut one end of each bracket piece at a 60-degree angle along the narrow width, for combining the pieces into equilateral triangles.

With the narrow width down, arrange three bracket pieces around the upright Sonotube (Figure 9, bottom). Adjust the bracket pieces so that their inside surfaces contact the Sonotube and their angled ends abut the adjacent bracket piece. The inside length of the resulting equilateral triangle will be 21 or 22 in. depending on the thickness of the paperboard cylinder, meaning that the square ends of the lumber will project about 1/2 ft.

Drill two pilot holes through the side of a bracket piece and into the end of an abutted 2 by 4. Connect these two bracket pieces through the pilot holes with two 3-1/2-in.-long drywall screws.

Repeat the procedure at the other two abutments of the triangular bracket, ensuring that all three bracket pieces fit snugly against the Sonotube.

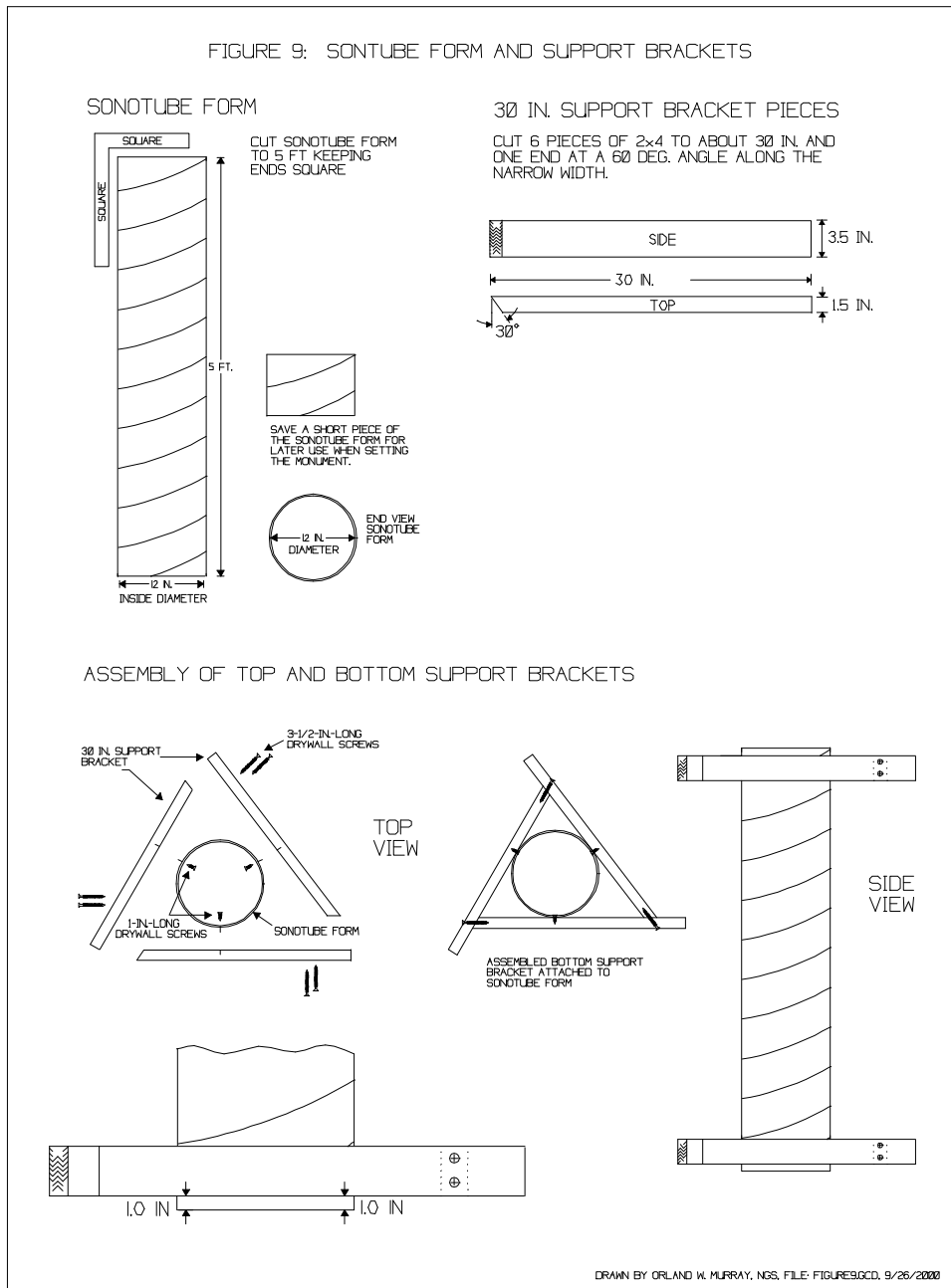

Figure 9 - Sonotube Form and Support Brackets

Raise the assembled bracket about 1 in. from the end of the Sonotube, and tip the construction on its side. From inside the Sonotube, use 1-in.-long drywall screws to secure the tube to the bracket at each of its three tangents.

Stand the Sonotube upright again but with the just-attached bracket at the top. Assemble the remaining three-piece bracket at the bottom of the Sonotube. If the CORS monument is being set on uneven terrain, this last assembled bracket may need to be raised more than 1 in. from the end of the Sonotube; otherwise raise the bracket only 1 in. and secure it from inside the tube at each of the three tangents.

For lower support braces that raise, lower, and plumb the Sonotube, cut three 24-in.-long pieces of 2 by 4 lumber (Figure 10). Overlap the lower support braces with the extended ends of the brackets by 4 or 5 in. Near the middle of the overlap, drill a pilot hole and drive a single 3-1/2-in.-long drywall screw just tight enough to allow the adjusting brace to pivot. Repeat for the other two corners of the lower bracket.

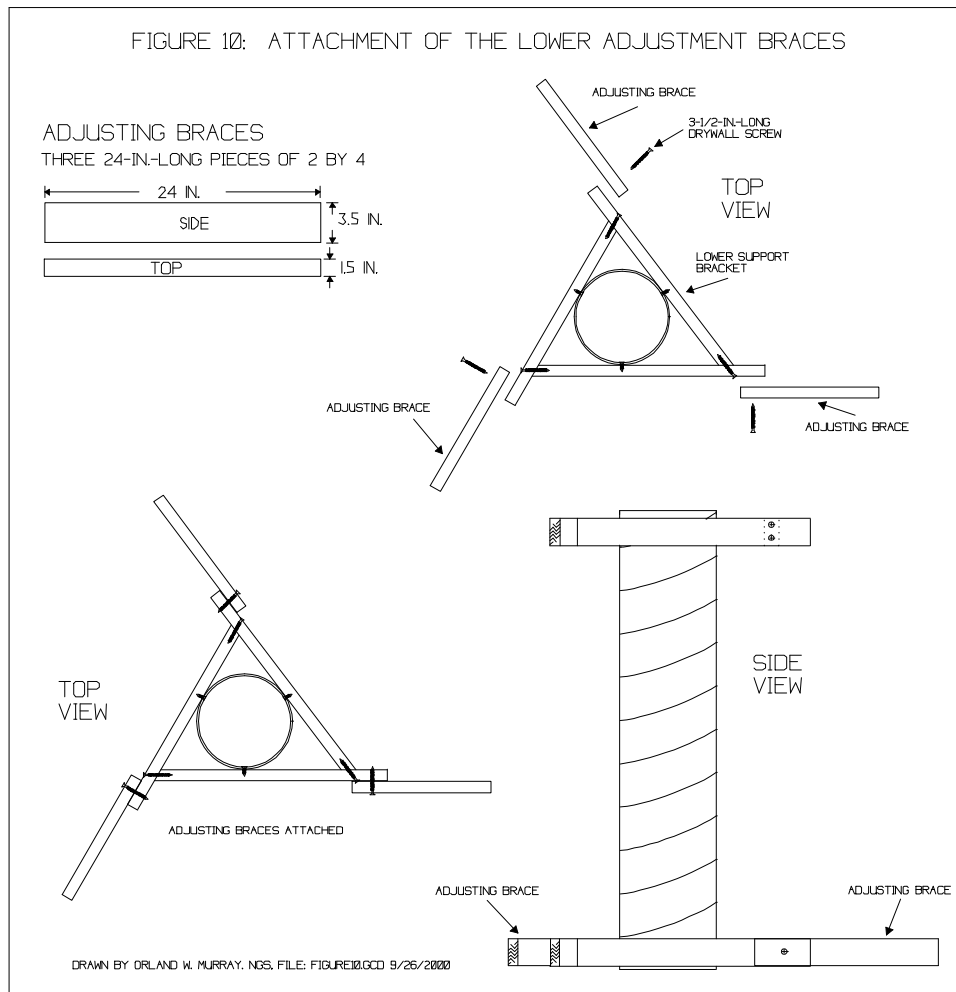

Figure 10 - Attachment of the Lower Adjustment Braces

Upper support braces consisting of 8-ft.-long 2 by 4 lumber are attached at the site.

## CONCRETE PIER

Design goals for the concrete pier are to supply reasonable stability at low cost. The belowground section of the pier should be at least 10 ft. deep and at least 1-1/2 ft. in diameter to counter near-surface sources of instability, and the aboveground section of the pier should be 5 ft. high and 1 ft. in diameter to counter signal multipath. Limiting the height of the pier to 5 ft. allows the use of geodetic levels to establish an orthometric height at the antenna reference point (ARP).

### Services:

- Safety check for underground utilities
- Drill the large-diameter hole for the belowground section of the pier
- Mix and deliver the concrete
- Rent a vibrator to consolidate the semifluid concrete

### Materials:

- 1 Assembled antenna mount
- 1 Assembled C-Bar reinforcement assembly
- 1 Assembled Sonotube form with lower support braces
- 1 Short piece of Sonotube, 1 ft.-tall or less
- 3 8-ft.-long 2 by 4 lumber
- 6 1-1/2-ft.-long by 2- by 2-in. or 1- by 2-in. wooden stakes
- box 3-1/2-in.-long drywall screws
- 1-2 yd Concrete

### Tools:

- 1 Tape measure
- 1 Shovel and hoe
- 1 Concrete vibrator
- 1 Carpenter's level
- 1 Short stepladder
- 1 Hammer
- 1 Cordless drill or screwdriver
- 1 Trowel

A safety check to confirm the absence of underground utilities is required in many states. Contact such a service at least 48 hours prior to digging.

Although it is possible to drill the hole and pour the concrete in the same day, schedule the services on consecutive days to allow time to resolve any unexpected problems that might occur



during the drilling process. Highway engineering construction companies, electric utility companies, and state departments of transportation are likely to have large-diameter augers.

The following information is adapted from *Design and Control of Concrete Mixtures*, S.H. Kosmatka and W.C. Panarese, 1988, Portland Cement Association, Skokie, Illinois.

Concrete is comprised of portland cement, fine and coarse aggregate, water, and air. Less water translates to stronger, better quality concrete, provided such stiffer mixes can be consolidated. Larger aggregates result in improved economy, provided they do not result in entrapped air voids. Entrainment of microscopic air bubbles up to 8% absolute volume increases the durability of concrete at the expense of strength.

Especially desired qualities for a CORS monument are quick service and durability. For these reasons, Type IIIA (high early strength, air entraining) portland cement is recommended.

Type III cement reaches strengths in less than a week that are comparable to Type I (normal) cement strengths at 28 days, allowing the monument to be used sooner. While richer mixes of Type I cement can achieve early strength gain, the results may not be as satisfactory or economical.

Entrained air is required for concrete exposed to freezing and thawing and to sulfate attack from natural salts found in soils. Entrainment of air can be achieved by adding an agent at the mixer or by using an air-entraining dry cement. Use of the agent during mixing allows fine adjustment to the volume percentage of entrained air; use of air-entraining dry cement ensures standard results.

Additional parameters necessary for the design and mixing of concrete are required strength, maximum water-cement ratio, maximum size aggregate, air content, and desired slump.

The concrete should be designed and mixed to obtain a minimum specified compressive strength of 2500 psi. For concrete exposed to freezing and thawing in a moist environment, the maximum ratio of the weight of water to the weight of cement should be 0.45. The maximum size of coarse aggregate should not exceed three-fourths the clear space between individual reinforcing bars nor three-fourths the clear space between reinforcing bars and the forms, meaning that aggregate size is limited to 2 in. by the space between the legs of the Delrin antenna mount. For 2-in maximum-sized aggregate and severe exposure to sulfate attack, the recommended volume of entrained air is 5.0 percent within -1 to +2 percentage points. The recommended slump is between 1 and 3 in. Given these guidelines, a local concrete supplier should be able to proportion the concrete mixture.

The mix is likely to be stiff, meaning that consolidation by mechanical vibration is required. A concrete vibrator is available from local rental companies.

The volume of a cylinder is calculated as pi multiplied by the radius squared multiplied by height ( $V=\pi R^2h$ ); thus the aboveground section of the pier has a volume of 3.9 cu. ft., and the minimum-dimensioned belowground section of the pier has a volume of 17.7 cu. ft. Because the action of the auger will enlarge the diameter of the hole, a minimum of 1 cu. yd. of concrete is required. Concrete suppliers are likely to assess a penalty for such a small quantity.

Measure the depth of the hole as the drilling progresses (Figure 11, left). Clear away the dirt from around the hole (Figure 11, middle), and confirm the final dimensions. Notify the concrete contractor if a revised volume of concrete is needed.

Begin pouring the concrete (Figure 11, right). Every 2 ft., embed the vibrator momentarily into the fresh concrete to remove entrapped voids. The mixture will segregate if the vibrator contacts the concrete for more than a few seconds.

When the concrete is 4-1/2 ft. below the ground surface, center and plumb the C-Bar reinforcement assembly within the hole (Figure 12, left). The reinforcing should project less than 4 ft. above the ground surface. Two people may be needed to hold the reinforcing plumb as the concrete fills the remainder of the hole and is consolidated (Figure 12, middle). With the concrete at the ground surface, confirm that the reinforcing is plumb, centered, and projects about 3-1/2 ft. (Figure 12, right).

Place the short piece of 12-in.-diameter Sonotube over the C-Bar reinforcement assembly. With the reinforcing centered within the Sonotube, indent the wet surface of the concrete, and remove the short piece of Sonotube (Figure 13, top). Carefully lift the 5-ft.-tall Sonotube form with brackets and lower it around the reinforcement (Figure 13, bottom). Set the Sonotube into the fresh indentation with the wooden lower support bracket resting on the ground surface. From atop a short stepladder, look down inside the Sonotube to ensure that the reinforcing is reasonably centered within the form.

Midway along the length of the bottom braces, drive a support stake solidly into the ground (Figure 14, top). Plumb the Sonotube form with the C-Bar reinforcement assembly centered within it. The bottom of the form should be slightly embedded into the concrete. Once the form is plumb, the C-Bar assembly is centered, and the form is at the correct height, drive a 3-1/2-in.-long drywall screw through the adjusting brace and into the support stake. Repeat for the other two bottom braces. Confirm the plumb and centering again before fixing the braces firmly to the bracket and to the stake with additional 3-1/2-in.-long drywall screws (Figure 14, bottom).

Place the end of an 8-ft.-long 2 by 4 against the extended end of the Sonotube top bracket and attach it with a single 3-1/2-in.-long drywall screw. Drive a support stake near the far end of the 2 by 4 where it rests upon the ground. Repeat for all three corners of the top bracket (Figure 15, top). Confirm the plumb and centering of the Sonotube form before driving a 3-1/2-in.-long drywall screw through the 2 by 4 and into each support stake. Use additional drywall screws to fix the three 8-ft.-long braces firmly to the upper bracket and to the stakes (Figure 15, bottom).

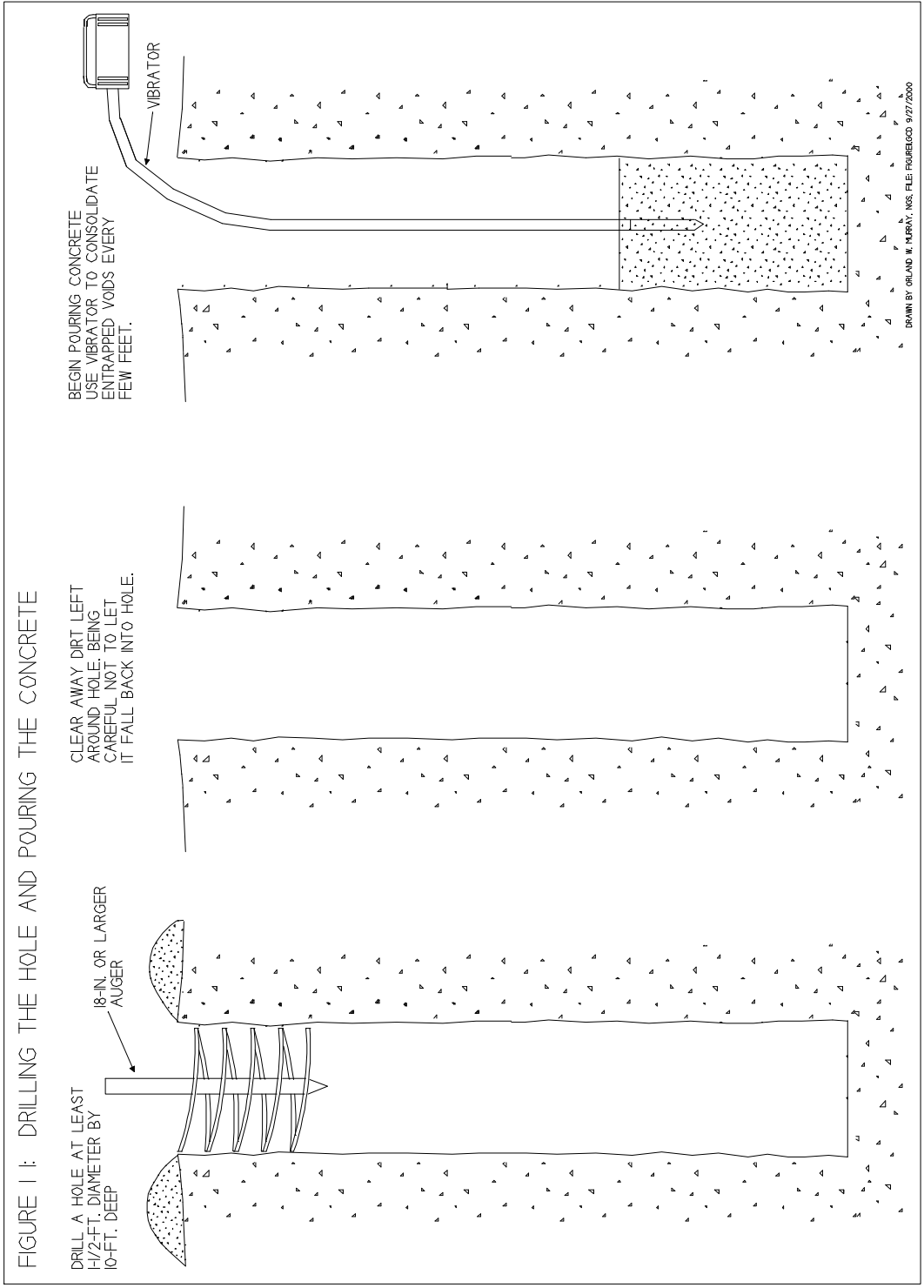
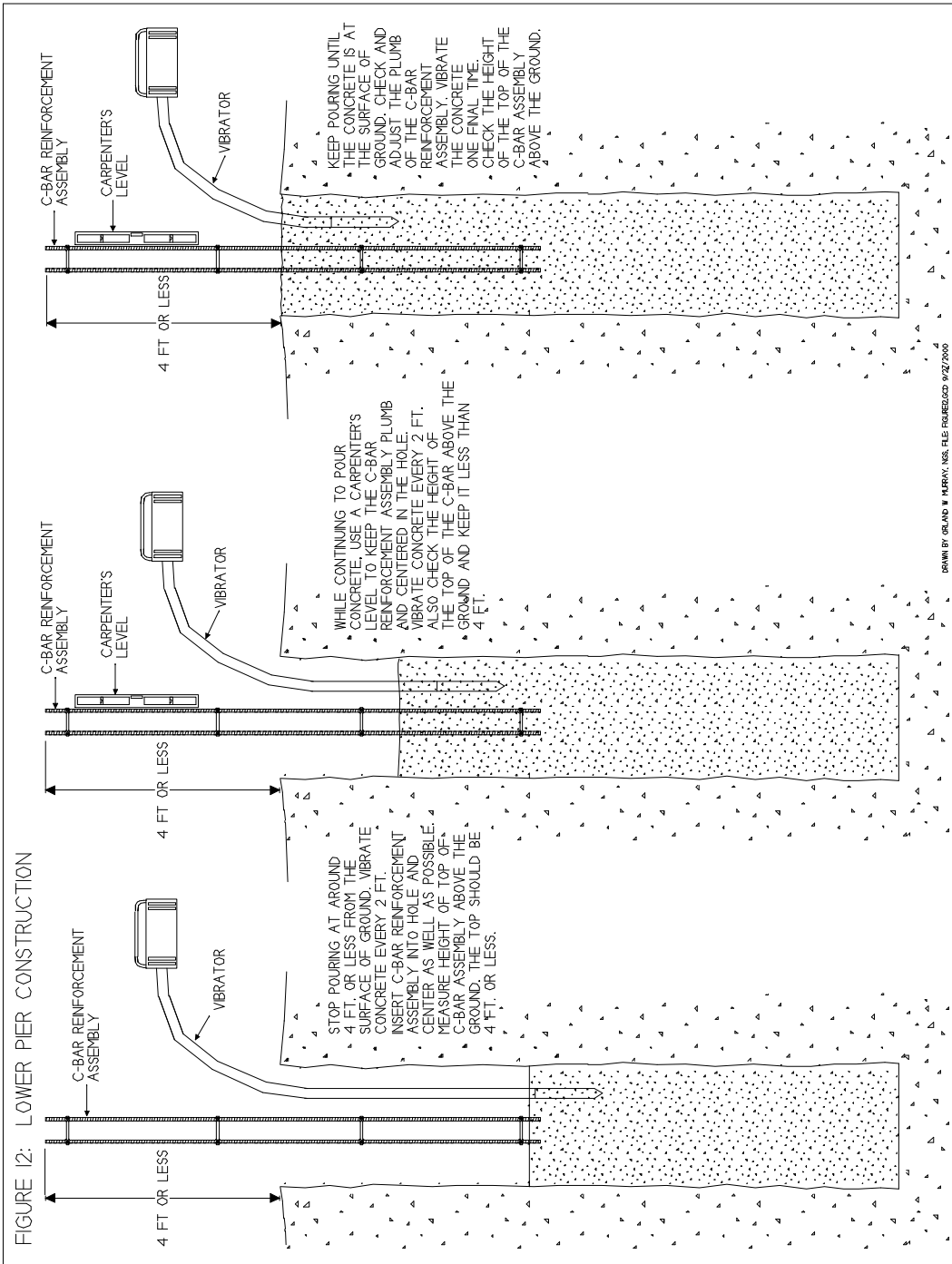

FIGURE 11: DRILLING THE HOLE AND POURING THE CONCRETE

Figure 11 - Drilling the Hole and Pouring the Concrete



DRAWN BY: ORLAND W. KURBY; NSL FILE: R02BEG00 9/22/2000

Figure 12 - Lower Pier Construction

# FIGURE 13: PLACING THE SONOTUBE FORM

## MARKING THE LOCATION OF THE SONOTUBE FORM

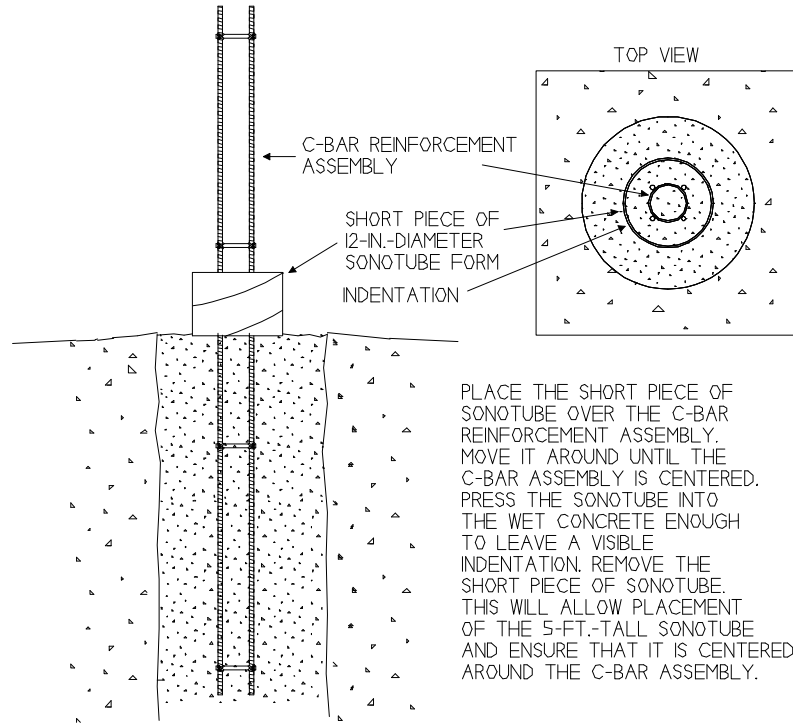

## SETTING SONOTUBE FORM IN PLACE

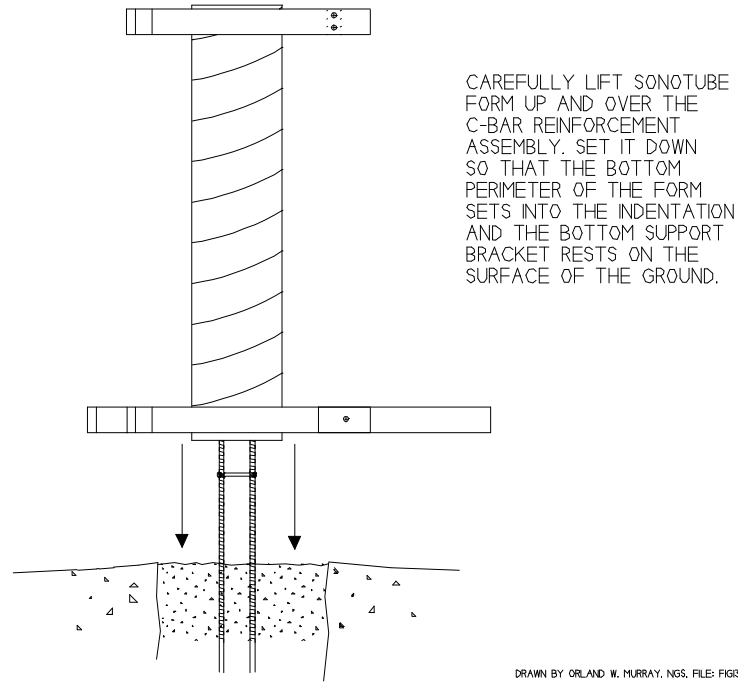

DRAWN BY ORLAND W. MURRAY, NGS, FILE: FIG13A.GCD, 9/27/2000

Figure 13 - Placing the Sonotube Form

FIGURE 14: BRACING THE BOTTOM OF THE SONOTUBE FORM

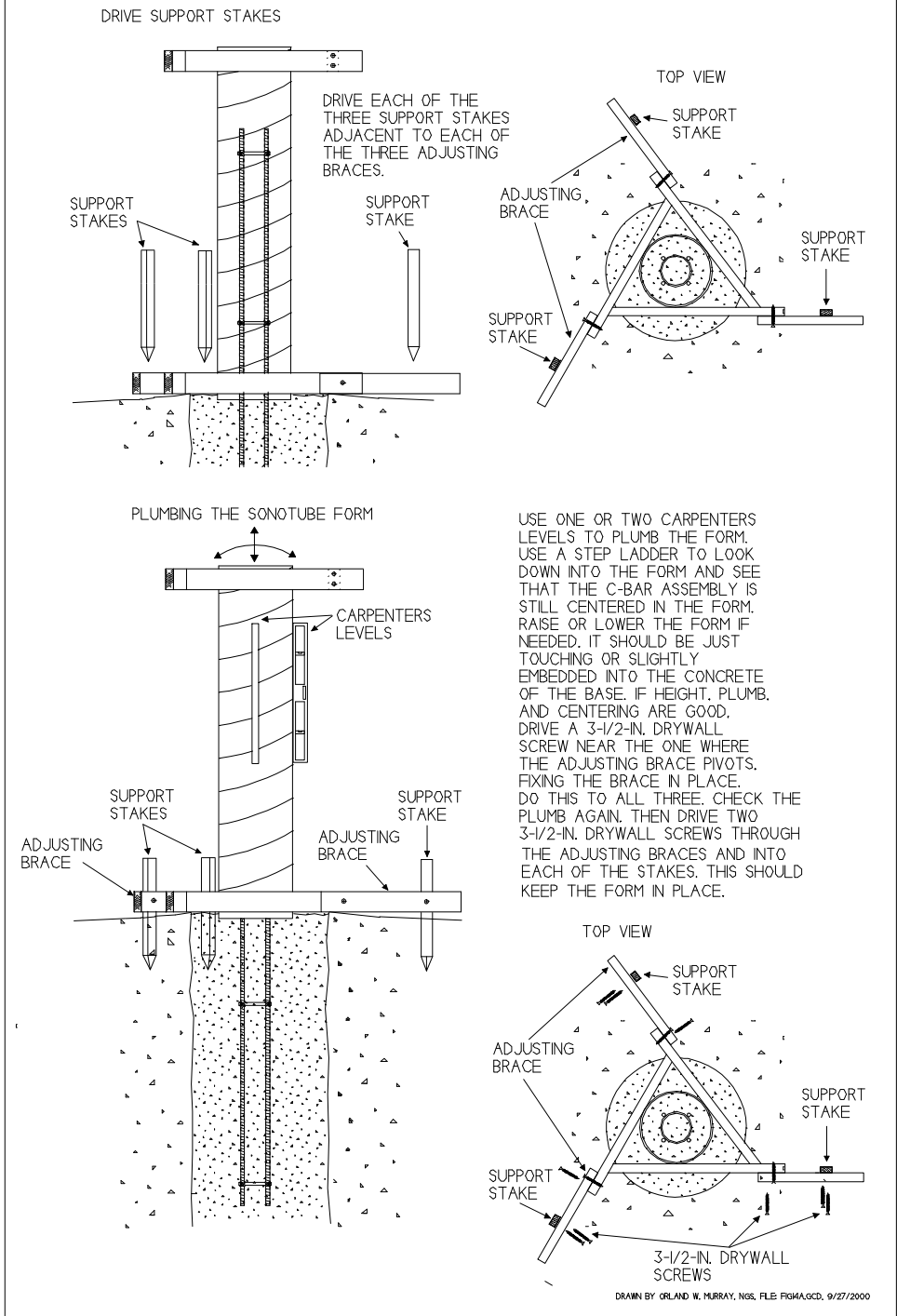

Figure 14 - Bracing the Bottom of the Sonotube Form

FIGURE 15: BRACING THE TOP OF THE SONOTUBE FORM

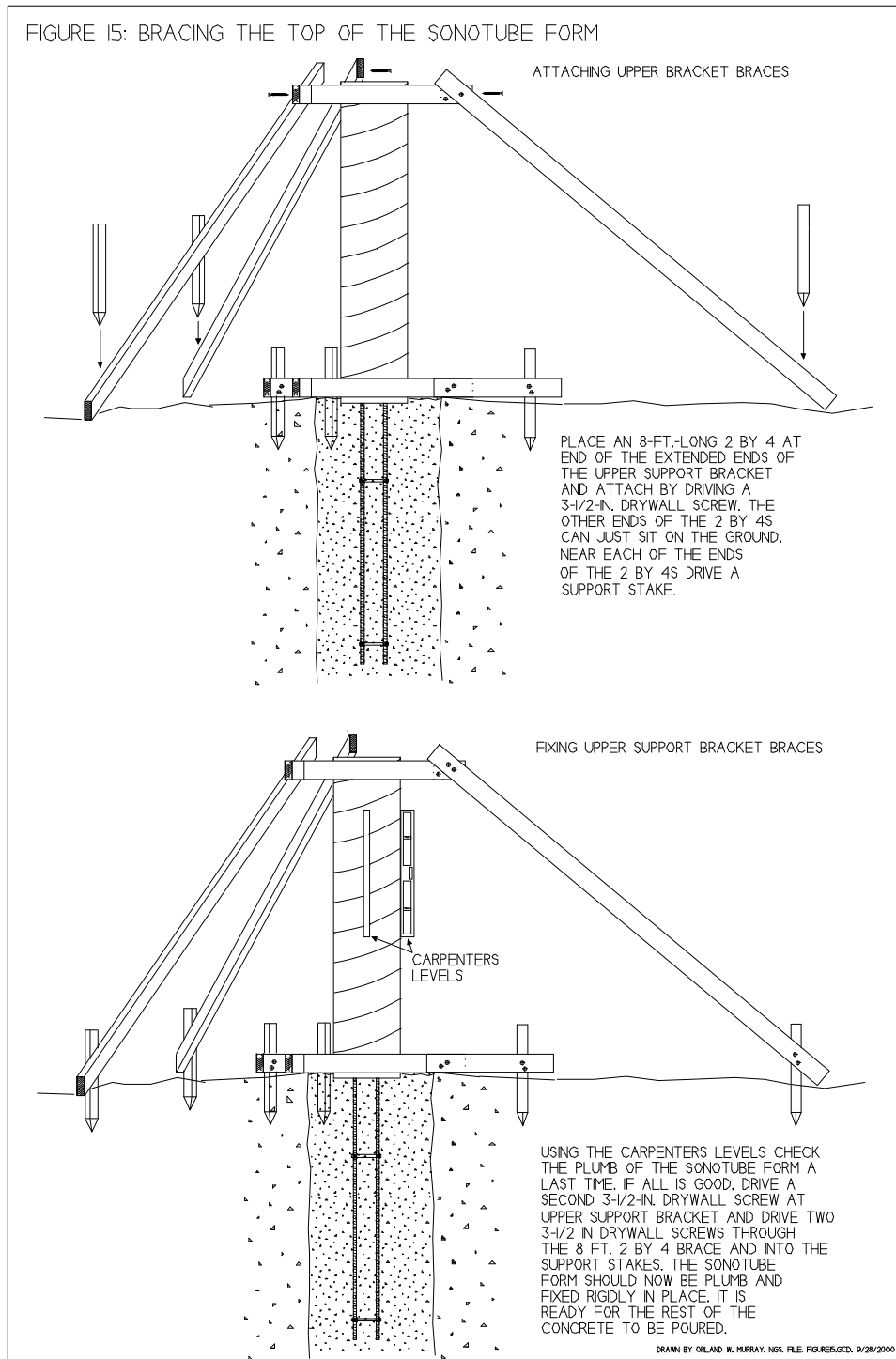

Figure 15 - Bracing the Top of the Sonotube Form

From atop a short stepladder, slowly shovel or hoe the semifluid concrete into the form, ensuring that the reinforcing remains centered. Every few feet, tamp the concrete to remove voids (Figure 16, top).

**WARNING: BY NO MEANS USE THE VIBRATOR TO CONSOLIDATE THE CONCRETE IN THE SONOTUBE FORM AS IT COULD POSSIBLY EXPLODE THE FORM!**

Keep pouring and hand-rodding the concrete, ensuring that the C-Bar reinforcement assembly remains centered in the Sonotube (Figure 16, bottom). When the Sonotube form is filled, use a trowel to smooth the top of the concrete pier prior to inserting the Delrin antenna mount (Figure 17, top).

Center the antenna mount above the pier and press the legs into the semifluid concrete (Figure 17, bottom). Press and wiggle the mount until the Delrin plate touches the concrete. Hand-rod the concrete around the Delrin legs to remove entrapped voids, then gently tap the Delrin plate to embed it 1/2 in. into the concrete surface.

Remove the brass adaptor plug and place a carpenter's level across the center of the tribrach adaptor (Figure 18, top). While observing the bubble on the level, rotate the level to determine any tilt of the mount. Remove the tilt by gently tapping the high area of the Delrin plate with the butt of the trowel handle (Figure 18, middle). Rotate the carpenter's level to ensure that the tribrach adaptor is level in all directions.

Use the trowel to smooth the top of the wet concrete, sloping the surface outward to direct water off the pier. When finished, confirm that the tribrach adaptor has remained level. Over the adaptor, orient a compass to *true* north, allowing for local declination. Record the direction in the wet concrete (Figure 18, bottom).

Cover the top of the pier with a plastic bag and tape it to the Sonotube. This will protect the wet concrete from rain and debris and will prolong the period of moist curing (Figure 19, top). Strength increases with age as long as the relative humidity within the concrete remains above 80%.

After three to seven days, the Sonotube form may be removed from the upper pier. The form is designed to peel along a spiral tear line (Figure 19, middle).

After several weeks, use RTV silicone sealant to prevent water seepage between the edge of the Delrin plate and the concrete pier. Use hydraulic cement to fill the indentation at the base of the upper pier caused by the Sonotube. Paint the monument with a white concrete sealant to repel water and radiant heat (Figure 19, bottom).



FIGURE 16: UPPER PIER CONSTRUCTION

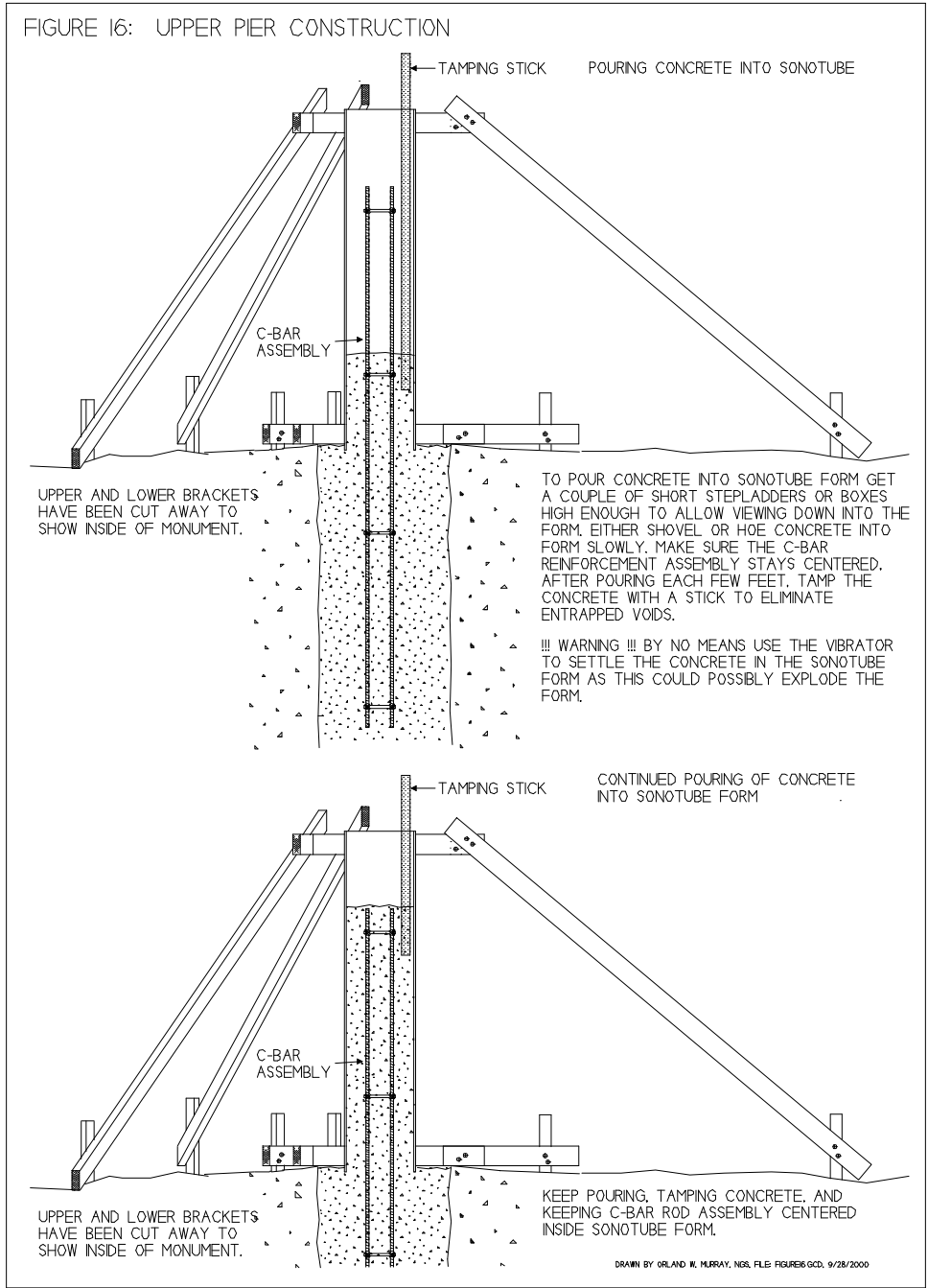
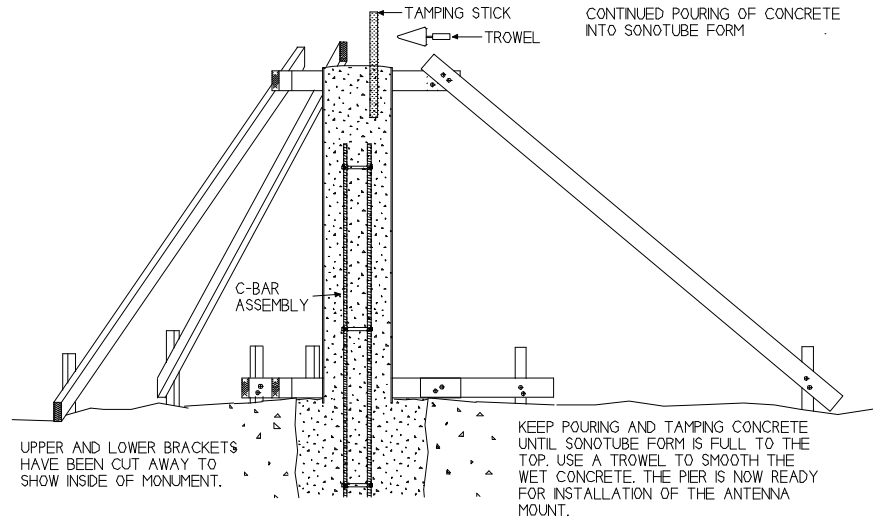

Figure 16 - Upper Pier Construction

FIGURE 17: PLACING THE ANTENNA MOUNT



ATTACHING THE ANTENNA MOUNT TO THE PIER.

PLACE THE ANTENNA MOUNT AS CLOSE TO THE CENTER OF THE TOP OF THE PIER AS POSSIBLE AND PRESS THE LEGS INTO THE WET CEMENT. WIGGLE THE MOUNT TO WORK IT IN UNTIL THE BOTTOM OF THE DELRIN PLATE TOUCHES THE CEMENT (INSETS A, B, C). USE A SMALL STICK TO TAMP AROUND THE MOUNT TO SETTLE THE CONCRETE AROUND THE NOTCHED LEGS (INSET C).

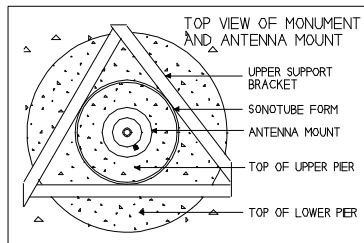
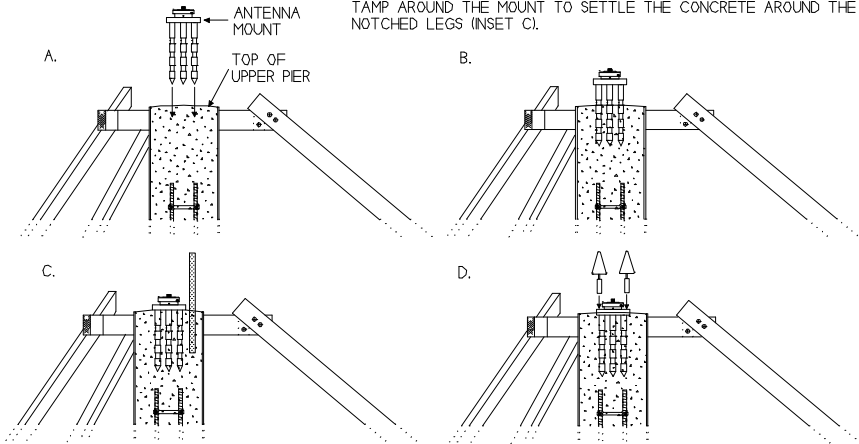

USE A STICK OR HANDLE OF A TROWEL TO GENTLY TAP THE TOP OF THE DELRIN PLATE (INSET D) TO CONSOLIDATE THE WET CONCRETE. KEEP TAPPING AROUND THE PLATE UNTIL IT IS EMBEDDED ABOUT 1/2 IN.

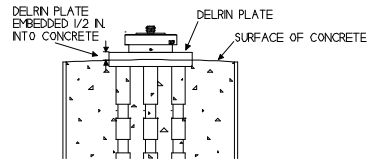

DRAWN BY GR/LAND W. HURRAY, NGS, FILE: FIGURE17.CCD, 9/28/2000

Figure 17 - Placing the Antenna Mount

FIGURE 18: LEVELING THE ANTENNA MOUNT

REMOVE THE ADAPTER PLUG (A) AND PLACE A CARPENTERS LEVEL ACROSS THE CENTER OF THE TRIBRACH ADAPTER (B). WHILE OBSERVING THE BUBBLE ON THE LEVEL, ROTATE IT EVERY 30 DEGREES (C) TO DETERMINE WHAT DIRECTION THE TRIBRACH ADAPTER IS TILTED. WITH THE LEVEL SITTING ON THE TRIBRACH ADAPTER, GENTLY TAP THE TOP OF THE DELRIN PLATE (D) WITH THE HANDLE OF THE TROWEL UNTIL THE LEVEL BUBBLE IS CENTERED. NEXT, ROTATE THE LEVEL AROUND AGAIN (E) TO BE SURE THE TRIBRACH ADAPTER IS LEVEL. KEEP CHECKING AND ADJUSTING UNTIL IT IS LEVEL (F) IN ALL DIRECTIONS.

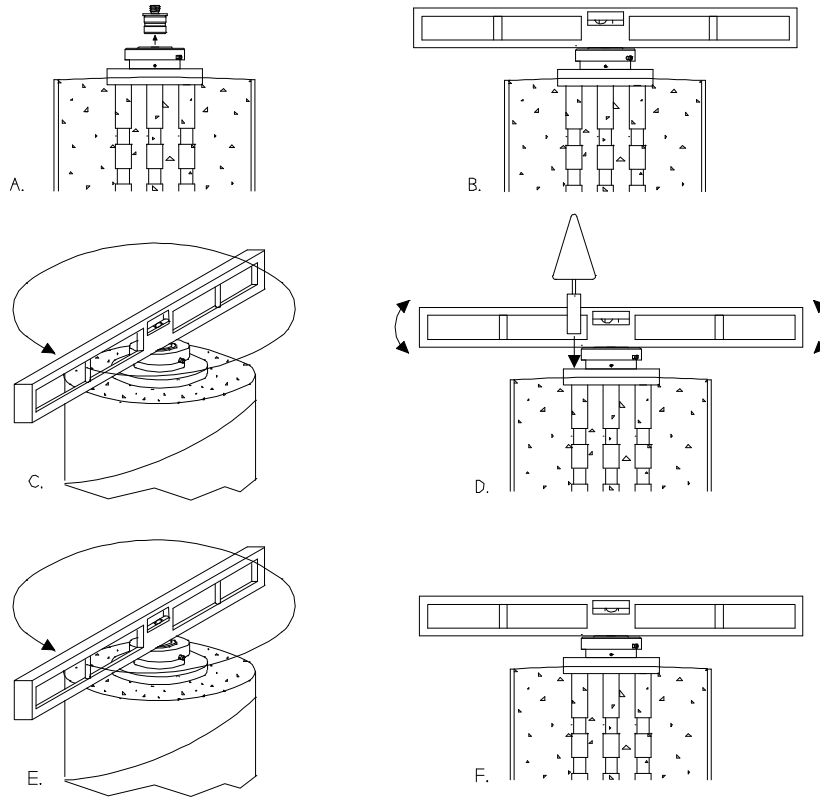

SMOOTH THE TOP OF PIER

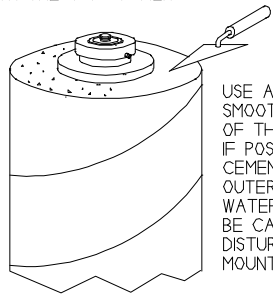

USE A TROWEL TO SMOOTH THE TOP OF THE CONCRETE. IF POSSIBLE, SLOPE CEMENT TO THE OUTER EDGE SO THAT WATER WILL RUN OFF. BE CAREFUL NOT TO DISTURB ANTENNA MOUNT.

MARK TRUE NORTH DIRECTION

CAREFULLY SET A COMPASS ON TRIBRACH ADAPTER AND ORIENT TO TRUE NORTH ALLOWING FOR LOCAL DECLINATION. MAKE AN ARROW IN THE CEMENT OR PLACE A BOLT INTO THE CEMENT TO MARK TRUE NORTH.

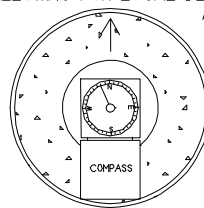

DRAWN BY ORLAND W. MURRAY, NGS, FILE: FIGURE8.GCD, 9/28/2000

Figure 18 - Leveling the Antenna Mount

FIGURE 19: FINISHING THE CONSTRUCTION

COVER TOP OF PIER DURING INITIAL CURING

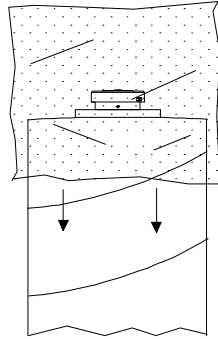

PLACE A PLASTIC BAG OVER THE TOP OF THE PIER AND TAPE IT TO THE SONOTUBE. THIS WILL PROTECT THE WET CONCRETE FROM RAIN AND DEBRIS WHILE IT IS CURING. BE CAREFUL NOT TO DISTURB THE ANTENNA MOUNT AND MOVE IT OUT OF LEVEL.

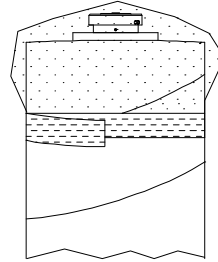

REMOVE SONOTUBE FORM FROM UPPER PIER

AFTER THREE TO SEVEN DAYS, REMOVE THE SONOTUBE FORM FROM THE UPPER PIER. THE FORM IS DESIGNED TO PEEL ALONG A SPIRAL TEAR LINE. START AT THE TOP WHERE THE SPIRAL GROOVE BEGINS AND PULL THE FORM AWAY FROM THE CONCRETE.

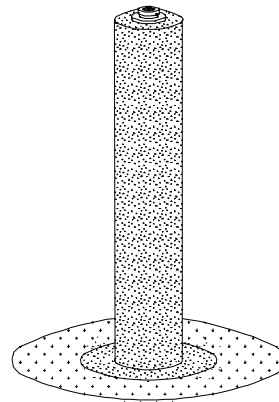
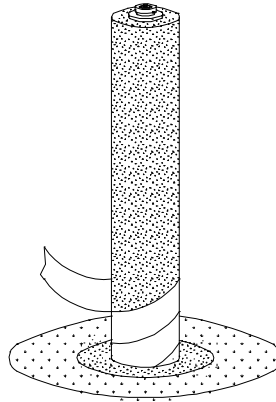
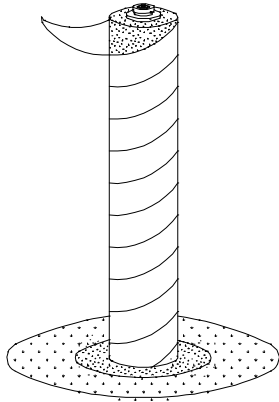

SEPARATION OF CONCRETE FROM ANTENNA MOUNT

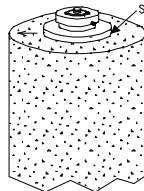

SEPARATION LINE  
WHILE CONCRETE IS CURING, OBSERVE THE LINE WHERE THE CONCRETE MEETS THE ANTENNA MOUNT DELRIN BASE PLATE. IF ANY SEPARATION SHOULD OCCUR, SEAL THE JOINT WITH RTV SILICONE TO PREVENT WATER SEEPAGE.

SEAL JOINT BETWEEN UPPER PIER AND LOWER PIER

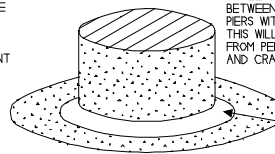

AFTER CONCRETE HAS CURED FOR A WEEK OR TWO, SEAL THE JOINT BETWEEN THE UPPER AND LOWER PERS WITH HYDRAULIC CEMENT. THIS WILL PREVENT ANY WATER FROM PENETRATING, FREEZING, AND CRACKING THE MONUMENT.

JOINT BETWEEN UPPER AND LOWER PERS

DRAWN BY ORLAND W. MURRAY, NOS. FILE: FIGURE19.DCD, 9/28/2000

Figure 19 - Finishing the Construction