

Feasibility Study to Reduce Injuries and Fatalities Caused by Contact of Cranes, Drill Rigs, and Haul Trucks with High-Tension Lines

H. Kenneth Sacks, *Member, IEEE*, James C. Cawley, *Senior Member, IEEE*, Gerald T. Homce, and Michael R. Yenchek, *Senior Member, IEEE*

Abstract—Overhead electric power lines present a serious electrocution hazard to personnel in a variety of industries. Overhead lines, typically uninsulated conductors supported on towers or poles, are the most common means of electric power transmission and distribution, and are exposed to contact by mobile equipment such as cranes and trucks. Equipment contacting energized overhead lines becomes elevated to a high voltage, and simultaneous contact by personnel of the “hot” frame and ground can cause serious electrical shock and burns. Industries where risk of these accidents is greatest include construction, mining, agriculture, and communications/public utilities. An estimated 2300 accidental overhead line contacts occur each year in the U.S. This paper describes a practical low-cost concept to detect actual contact of mobile equipment with a high-voltage line and provide a warning. Accident statistics indicate that more than half of the fatalities could be prevented by such a device.

Index Terms—Crane, electrical shock prevention, engineering control, mining, mobile equipment, power line.

I. INTRODUCTION

OVERHEAD electric power lines present a serious electrocution hazard to personnel in a variety of industries. Overhead lines, typically uninsulated conductors supported on towers or poles, are the most common means of electric power transmission and distribution, and are exposed to contact by mobile equipment such as cranes and trucks. Equipment contacting energized overhead lines can become elevated to a high voltage, and simultaneous contact of the “hot” frame and ground can cause serious electrical shock and burns. Industries where risk of these accidents is greatest include construction, mining, agriculture, and communications/public utilities. An estimated 2300 accidental overhead line contacts occur each year in the U.S. [1].¹

Construction activities present the most obvious potential for line contact accidents, and a recent study estimated that in 1993

Paper PID 01-00, presented at the 1999 Industry Applications Society Annual Meeting, Phoenix, AZ, October 3-7, and approved for publication in the IEEE TRANSACTIONS ON INDUSTRY APPLICATIONS by the Mining Industry Committee of the IEEE Industry Applications Society. Manuscript submitted for review October 15, 1999 and released for publication February 26, 2001.

The authors are with the Pittsburgh Research Laboratory, National Institute for Occupational Safety and Health, Pittsburgh, PA 15236 USA (e-mail: hes3@cdc.gov; gdh3@cdc.gov; mby5@cdc.gov).

Publisher Item Identifier: S 0093-9994(01)03916-0.

¹The estimate of 2300 line contacts per year was generated from 1994 OSHA data for all industries, and includes any contact of overhead lines, for example, direct contact by a person, handheld items, ground ladders, and scaffolding, in addition to mobile equipment

alone, at least 26 electrocutions in this industry were a result of heavy equipment or hoisted loads contacting overhead lines. Mobile cranes (including boom trucks) were involved in most of these incidents (57%), with drill rigs (8%), dump bed trucks (7%), and manlifts (7%) also common [2]. It should be noted that this summary likely understates the extent of the problem, due to reporting and data collection methods, as well as the omission of accidents resulting in nonfatal injuries. Detailed and more comprehensive statistics are available for the mining industry, which represents a smaller work force than the construction industry, but has a similar electrocution rate, and like construction uses heavy equipment extensively. From 1980 to 1997, at least 94 mobile equipment overhead line contact accidents were reported in the U.S. mining industry, with 114 injuries, 33% of them fatal. Most involved cranes (47%), dump bed trucks (24%), and drills (14%).

II. BACKGROUND

Investigations into possible means to prevent injuries caused by contact between power lines and cranes date back at least 28 years. In 1980, the U.S. Bureau of Mines contracted with the Southwest Research Institute (SWRI), San Antonio, TX [3], to study commercial devices sold to protect crane operators from contact with overhead high-voltage lines. SWRI acquired and tested three commercial devices. The proximity warning devices, as they were generally known, all purported to warn against impending contact with power lines. The SWRI phase I report concluded [3, p. 10]:

However, all of the devices tested and, in fact, any proximity warning device based only upon electrostatic field sensing will fail to alarm reliably under certain configurations of multiple power line circuits.

Other common prevention techniques are discussed in 29 CFR 1910.333(c)(3) and 29 CFR 1926.550(a)(15) [4], [5]. These include deenergizing lines, maintaining appropriate distances from energized lines, use of an observer to warn the operator of impending contact, and barriers to prevent physical contact with an energized line [4]–[6].

One technique, the use of insulating links in the load line, attempts to prevent injury once contact has been made. Analysis of the properties of these links [7] show they can greatly increase worker safety. However, surface contamination and moisture can reduce their insulation resistance and workers who contact parts of the crane other than the load will not be protected.

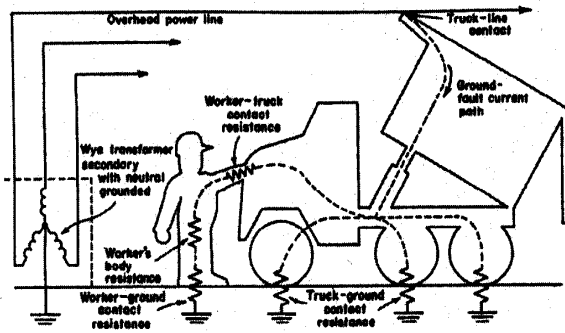

Fig. 1. Schematic of a power line contact.

The technical approach in this paper assumes that contact with a power line has occurred. The question was whether or not electrical currents flowing through a vehicle in contact with a high-voltage source could be practically detected and trigger an alarm. The alarm would then warn the operator and bystanders that the vehicle is a serious electrocution hazard and should not be approached (or dismounted by the operator). Clearly, victims in contact with the crane or a conductor electrically connected to the crane (control pendent or load line) at the instant of contact with the power line would not be protected.

Two databases of electrocutions were analyzed. The National Institute for Occupational Safety and Health (NIOSH) does detailed investigations of fatal accidents through its Fatal Assessment and Control Evaluation program (FACE). Forty accidents involving crane electrocutions were investigated between 1982–1994 [8]. Of these fatal incidents, 20% could have been prevented with a contact alarm system. A second analysis showed that 55% could have been avoided through a combination of insulating load link and a contact alarm. The second database was the Mine Safety and Health Administration's (MSHA's) Part 50 mining injury and illness database.² From 1980 to 1997, there were 89 mobile equipment/overhead line accidents that resulted in injury. Of these, 73 incidents had sufficient information to evaluate the utility of a "contact alarm." A conservative estimate is that 56% of the victims could have been saved with such an alarm. Again, a second analysis showed that the contact alarm coupled with an insulating link could have saved 77% of the victims. NIOSH [5, p.2] reports that at least 15 people are electrocuted each year from contact between cranes or similar vehicles and power lines. The implication is that this device coupled with an insulating link could save eight or more lives every year.

III. EXPERIMENTAL APPROACH

Fig. 1 shows that, in the event of line contact, current can flow from the power line through the vehicle to earth, via the vehicle's ground contact, and back to the grounded point of the

²MSHA is required by law to maintain detailed injury statistics for the mining industry and publishes its results quarterly as the *Mine Injuries and Worktime, Quarterly*

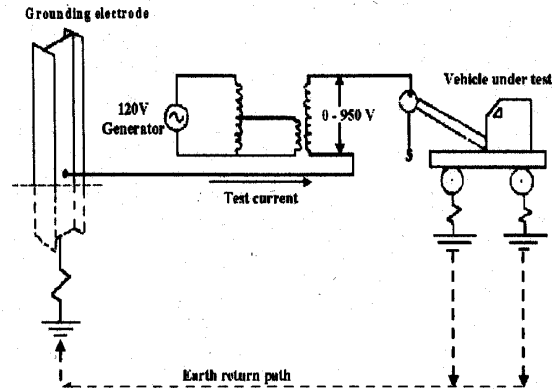

Fig. 2. Schematic representation of the tests done at LLL.

source transformer feeding the lines. To gauge the feasibility of a contact alarm, it is necessary to learn more about how the electrical current flows within the vehicle framework from the line to the earth. Specifically, the question that needs to be answered is whether a signal derived from the vehicle can be used to alarm those nearby. A realistic experimental protocol involves the application of voltages, of the same order of magnitude as power lines, to vehicles representative of those involved in fatal incidents. Experiments of this nature are potentially hazardous and must be done at an isolated location. Consequently, all field tests were conducted at the Lake Lynn facility of the Pittsburgh Research Laboratory (PRL).

The Lake Lynn Laboratory (LLL) [9] is located approximately 14 miles south of Uniontown, PA, on the border with West Virginia. It encompasses about 400 acres and a former limestone mine, now used for fire and explosion research. The remote surface facility features a variety of test beds at the base of a highwall including grassy fields, gravel roads, and a quarry floor. In addition, mobile vehicles similar to those found on mining and construction sites are available for the tests.

To ensure that test currents through the earth did not pose a hazard to personnel working nearby, it was necessary to devise a test circuit that was electrically isolated from the utility distribution at Lake Lynn. This was best accomplished using a portable gasoline generator as the test power source. As shown in Fig. 2, this 120-V, 2.3-kVA generator was connected to a variable transformer and a step-up transformer to provide test voltages ranging from 0 to 950 V. In the experiments to follow, this output was connected to the vehicle under test and to an earth grounding electrode to simulate the grounded point of a source transformer. A partially buried I-beam at Lake Lynn was selected as the grounding electrode for the experiments. As shown in Fig. 2, this electrode will exhibit a measurable resistance to remote earth. Using a three-point fall of potential method [10], the resistance to remote earth from this ground electrode was measured at 8 and 12 Ω under wet and moist conditions, respectively, across the grassy area.

Also shown in Fig. 2, the vehicle contact with earth will exhibit resistance. This resistance is directly related to the resistivity of the underlying earth, the area of contact or footprint [11] and, indirectly, to the force of the contact. The earth resistivity

TABLE I
MEASURED GROUND RESISTIVITY FOR THREE TEST AREAS AT LLL

	Grassy Area	Gravel Road	Quarry Floor
Moist Conditions	9,521-18,605 ohm-cm	14,402-37,245 ohm-cm	N/A
Wet Conditions	5,800-15,960 ohm-cm	10,704-21,293 ohm-cm	51,755-100,031 ohm-cm
Typical Handbook Values	Clay soils - 200-10,000 ohm-cm	Sand and gravel - 5,000-100,000 ohm-cm	Surface limestone - 10,000-1,000,000 ohm-cm

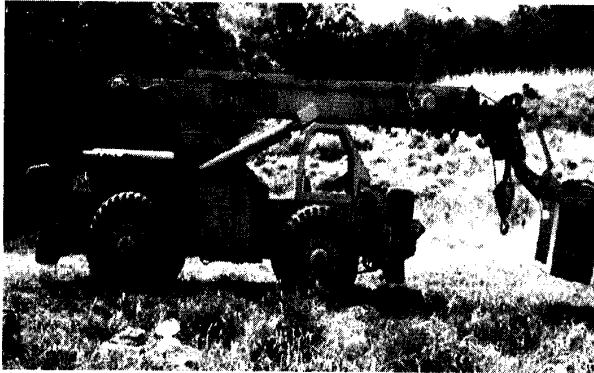

Fig. 3. Pettibone crane at LLL.



Fig. 5. Ford F800 single-axle dump truck at LLL.

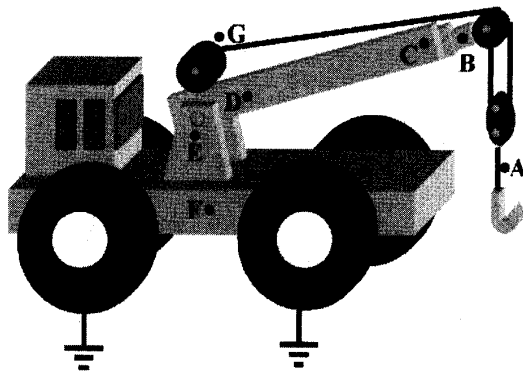

Fig. 4. Illustration of Pettibone crane measurement points.

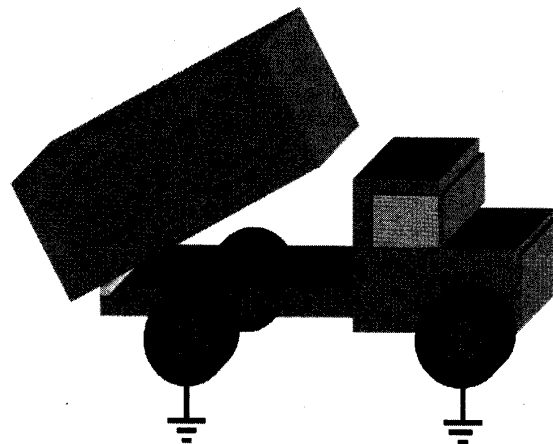

Fig. 6. Illustration of Ford F800 measurement points.

was measured using the four-terminal method [5, p. 8]. Three potential vehicle test sites at Lake Lynn were evaluated under both moist and wet conditions: 1) a grassy area representative of unbroken soil covered with grass; 2) a road covered with fine crushed slag, typical of an improved, temporary road surface; and (3) a quarry floor consisting of limestone bedrock, sparsely covered with loose soil and rock debris. The measured ground resistivities and typical handbook values [5, p. 8] are shown in Table I.

Next, two vehicles commonly involved in line contact incidents were selected for the tests. The first vehicle, a Pettibone MultiCrane, Model 15, 8-t maximum capacity (Fig. 3), estab-

lished ground contact through four rubber tires or through four hydraulically deployable steel stabilizers. Each stabilizer had approximately an 18-in \times 20-in footprint when in contact with the ground.

There are a variety of locations on a crane which may make contact with an energized line and affect the resultant current flow. To facilitate connection with the test voltage, 3/8-in-diameter threaded studs were welded on the vehicle at locations shown in Fig. 4 (except for A and G on the load line itself).

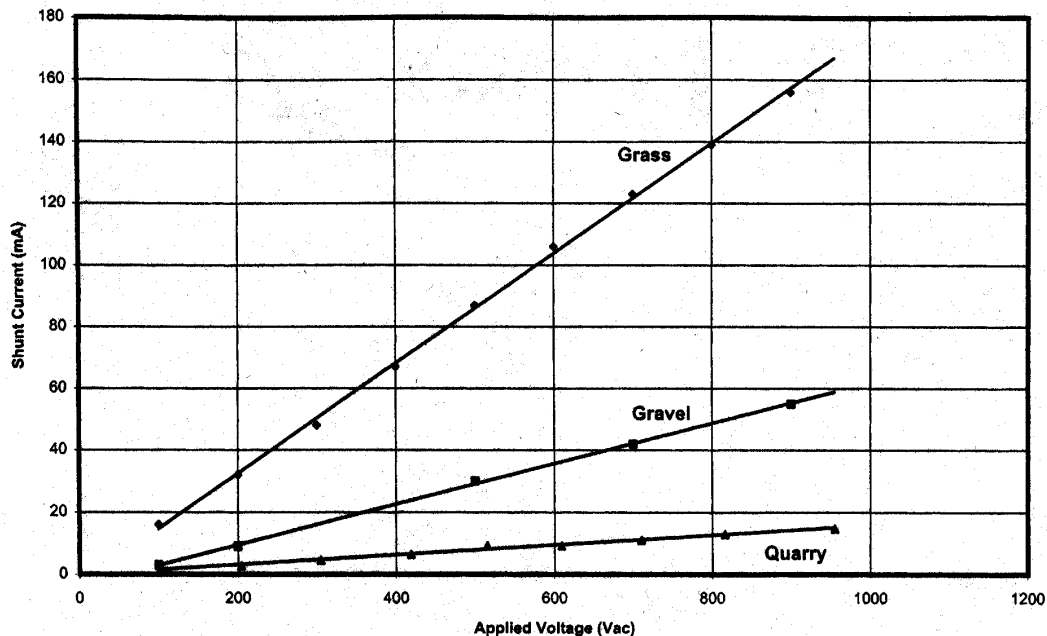

Fig. 7. Shunt currents for Ford F800 truck with bed in up position.

The second vehicle used in the test program was a Ford F800, single-rear-axle dump truck, with dual rear tires (Fig. 5). The most common hazard scenario for this vehicle is overhead line contact while raising its bed or moving with the bed up. Therefore, all measurements on this vehicle were made with the bed in the raised position.

The drawing of Fig. 6 shows the points on the dump truck where voltages were applied and current measurements recorded.

IV. RESULTS

A. Ford F800 Dump Truck

The drawing of Fig. 6 shows the points on the dump truck where voltages were applied and current measurements recorded. In general, voltages were applied to point A and currents were measured using an ammeter or a current transformer (CT) on a #2 AWG cable connected between points A and B. When parked on grass-covered soil, the F-800 dump truck exhibited total current flows as high as 250 mA as measured with an ammeter. Measuring from point A to point B showed considerable current flow in a shunt wire from A to B. This connection bridged the bed pivot point.

Measurements made when the truck was on the quarry floor are an order of magnitude lower. The small current is characteristic of the F800's tires on a hard, dry limestone surface. Scaling the applied voltage to more typical power line voltages will yield currents that are easily used to trigger an alarm when power line contact is made. Representative measurements made on the three terrains are shown in Fig. 7.

B. Pettibone Crane

Measurements on the Pettibone crane consisted of both direct readings taken with ammeters and voltmeters and measurements

taken with CTs. Measurement points on the Pettibone crane, shown in Fig. 4, are as follows:

- A end of wire rope;
- B end of boom;
- C end of main section of boom;
- D base of main section of boom;
- E boom support;
- F vehicle frame;
- G base of wire rope.

Measurements established how much current would flow in the Pettibone crane under various circumstances. The stabilizer down deployment represents the most common working posture for the Pettibone crane and its best contact with ground on typical soils. Current and voltage were applied and measured at various points during the course of the experiments and representative results for the three terrains are summarized in Fig. 8.

V. CONCLUSIONS

Experiments on two vehicles resting on three types of terrain revealed that measurable currents flowed through the vehicles to remote ground without any special vehicle-to-ground contact. This was true at moderate voltages less than 1000 V and ground resistivities from 6000 to 100 000 Ω -cm. Further, it was found that the vehicle was far from an equipotential surface and it was relatively easy to find points at different voltages. This allowed currents to be measured by simply shunting two convenient points on the vehicle and monitoring current flow with a current transformer. The magnitude of the measured currents was sufficient to allow relatively inexpensive techniques to detect them and trigger a warning signal. The experiments proved conclusively that a simple warning device was feasible and potentially highly effective in preventing electrocutions associated with power line contact. Based on these results, a Report of In-

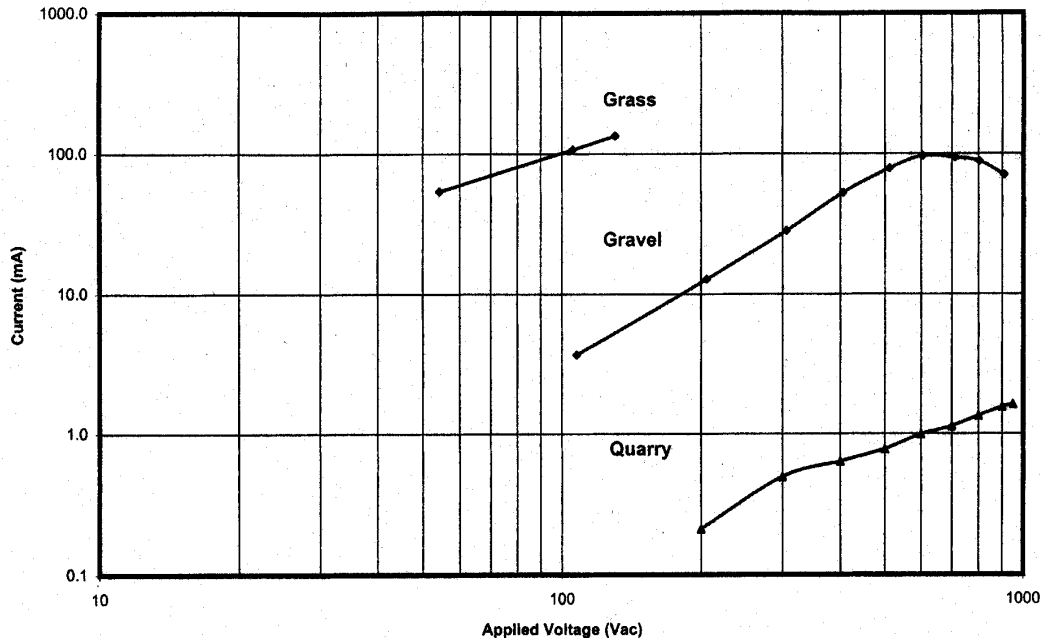

Fig. 8. Shunt currents for Pettibone crane with stabilizers down.

vention (EIR no. I-031-98/0—High Voltage Alarm System) was submitted.

VI. FUTURE WORK

The experiments carried out between April 13, 1998 and July 31, 1998 proved that a high-voltage contact alarm is feasible. Two important issues remain unresolved: 1) the problem of designing failsafe circuits in the presence of high voltage, and 2) the effectiveness of the concept in environments such as asphalt or concrete roadways. Other issues that will be addressed if appropriate test vehicles can be found are: 1) the effect of tire age and condition on current flow, and 2) mechanical difficulties with attaching cables for current measurement between moving sections of vehicles. The research team at PRL proposes to continue its work to answer these questions, with the result being a working model of the high-voltage alarm.

REFERENCES

- [1] *Mobile Crane Safety Course*, Crane Institute of America, Inc., Maitland, FL, Sept. 1998.
- [2] *Power Line Hazards Instructor Manual*, Construction Safety Council, Hillside, IL, 1996.
- [3] "Evaluation of proximity warning devices," Southwest Research Institute, San Antonio, TX, Contract J0188 082, Feb. 1980.
- [4] *Code of Federal Regulations*. Washington, DC: U.S. Government Printing Office.
- [5] "Preventing electrocutions of crane operators and crew members working near overhead power lines," NIOSH, Morgantown, WV, NIOSH Alert, DHHS (NIOSH) Pub. 95-108, May 1995.
- [6] L. A. Morley, F. C. Trutt, and G. T. Homce, *Volume IV—Overhead Line Contact Fatalities*. University Park, PA: Penn. State Univ. Press, 1981.
- [7] G. G. Karady, "Efficiency of insulating link for the protection of crane workers," *IEEE Trans. Power Delivery*, vol. 6, pp. 316–323, Jan. 1991.
- [8] P. H. Moore, private communication, Mar. 1998.
- [9] R. H. Mattes, A. Bacho, and L. V. Wade, "Lake Lynn Laboratory: Construction, physical description, and capability," Pittsburgh Research Laboratory, NIOSH, Pittsburgh, PA, BuMines Inform. Circular 8911, 1983.

- [10] "Getting down to earth," Biddle Instruments, Blue Bell, PA, 1982.
- [11] *IEEE Guide for Safety in AC Substation Grounding*, Std 80-1986 (R1991), 1991.

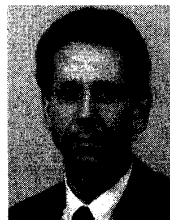

H. Kenneth Sacks (S'62–M'68) received the B.S.E.E. degree from the University of Maryland, College Park, the M.S.E.E and Ph.D. degrees from Carnegie-Mellon University, Pittsburgh, PA, and the M.B.A. degree from the University of Pittsburgh, Pittsburgh, PA, in 1982.

He is currently a Senior Scientist with the Pittsburgh Research Laboratory, National Institute for Occupational Safety and Health, Pittsburgh, PA.



James C. Cawley (M'82–SM'83) received the B.S.E.E. degree from The Pennsylvania State University, University Park, and the M.B.A. degree from the University of Pittsburgh, Pittsburgh, PA.

He designed vibration monitoring instrumentation for Reliance Electric Company, Columbus, OH, and industrial communications systems for Marshall Electronics Company, Pittsburgh, PA, prior to joining the U.S. Bureau of Mines' Pittsburgh Research Center, Pittsburgh, PA. In positions there as an Electrical Engineer and later as an Engineering

Supervisor, he was active in the fields of intrinsic safety, explosion-proof enclosures, and mine electrical systems and diagnostic systems for mine machinery. Since the activities of the former U.S. Bureau of Mines were assumed by the National Institute for Occupational Safety and Health, he has worked on electrical safety issues related to overhead power-line contact with cranes and trucks and in the causal analysis of electrical incidents.

Mr. Cawley is a Registered Professional Engineer in the Commonwealth of Pennsylvania.



Gerald T. Homce received the B.S. degree in mining engineering and the M.S. degree in mining engineering with a minor in electrical engineering from The Pennsylvania State University, University Park, in 1981 and 1983, respectively.

He was an Engineering Trainee with the Northern Coal Mining Division, Republic Steel Corporation, while attending The Pennsylvania State University, and was later the Supervisory Mining Engineer for underground operations of Myco-Sci, Inc., Worthington, PA. From 1985 to 1997, he was with

the U.S. Bureau of Mines at the Pittsburgh Research Center. As an Electrical Engineer for the Bureau, he conducted research into the safety and efficiency of mine electrical systems, with emphasis on the early detection of electric motor failures. He is currently an Electrical Engineer with the National Institute for Occupational Safety and Health, Pittsburgh, PA. As part of the Mining Injury Prevention Branch at the Pittsburgh Research Laboratory, his research focuses on preventing occupational electrical injuries, with emphasis on overhead power line hazards. He is co-holder of a patent for a mobile equipment power line contact alarm, and is also involved in agricultural equipment safety research.

Mr. Homce is a Registered Professional Engineer and a Licensed Mine Foreman in the Commonwealth of Pennsylvania. He is also a member of the Society for Mining, Metallurgy, and Exploration.



Michael R. Yenchek (S'70-M'71-SM'89) received the B.S.E.E. and M.S.E.E. degrees from the University of Pittsburgh, Pittsburgh, PA, in 1971 and 1977, respectively.

From 1971 to 1980, he was an Electrical Engineer with the Coal Mine Safety and Health Division of the Mine Safety and Health Administration. He joined the Pittsburgh Research Laboratory, U.S. Bureau of Mines (now National Institute for Occupational Safety and Health), Pittsburgh, PA, in 1980 and is currently the Chief of the Protective Equipment

Section of the Mining Injury Prevention Branch. He has been responsible for research programs concerning grounding and ground fault, dc haulage, motor, and trailing cable protection.

Mr. Yenchek is a member of Eta Kappa Nu and a Registered Professional Engineer in the Commonwealth of Pennsylvania.