



Putting Energy Into Profits

ENERGY STAR® Guide for Small Business



This report was prepared as an account of work sponsored by an agency of the United States Government. Neither the United States Government nor any agency thereof, nor any of their employees, makes any warranty, express or implied, or assumes any legal liability or responsibility for the accuracy, completeness, or usefulness of any information, apparatus, product, or process disclosed, or represents that its use would not infringe privately owned rights. Reference herein to any specific commercial product, process, or service by trade name, trademark, manufacturer, or otherwise, does not necessarily constitute or imply its endorsement, recommendation, or favoring by the United States Government or any agency thereof. The views and opinions of authors expressed herein do not necessarily state or reflect those of the United States Government or any agency thereof.

Foreword

As we embark on the 21st century, conserving our natural resources will be a necessity rather than an option. Energy efficiency will be at the forefront because it is financially, as well as environmentally, beneficial. Through energy efficiency, we can prevent pollution at a profit.

Energy productivity investment is most important to the business world, since the difference in gaining a profit or taking a loss is dependent on having a reliable power source and staying “connected.” One also has to pay the bill, so there is no merit to using more than you must.

This guide – *Putting Energy Into Profits, The ENERGY STAR® Guide for Small Business* – is designed to educate and assist the small business community in taking advantage of the benefits of energy efficiency. Whether you own your own building or are a tenant, you want lighting, heating, air-conditioning, and power for office equipment, and other services at the lowest possible

cost. This guide can help you identify building equipment and systems that need to be upgraded to help you save on your bottom line. We call this energy optimization; you will just call it smart business.

Along with the ENERGY STAR for small business program, there are other complementary organizations, programs, and resources available to help small businesses stay competitive in today’s economy. Two of these are the U.S. Department of Energy’s Rebuild America program and the National Trust for Historic Preservation’s National Main Street Center program.

Each of these programs offers a tremendous list of resources and experts. You can review some of them in the “Resources” section of this guide. The paragraphs below provide a brief overview of each of the programs that are “strategic partners” in serving small business, and that have contributed to the development of this guide.

About ENERGY STAR for Small Business

ENERGY STAR for small business provides access to a range of technical materials and services. These services include a toll-free hotline at 1-888-STAR YES, and an award-winning Web site at www.energystar.gov for free engineering support, including all your questions, product information, and calculations. You can become an ENERGY STAR partner through the hotline or Web site, and request publications, brochures, and information that you can use to highlight your “success story” for your customers and employees. There is even an annual national awards program.

You may discover that you can do certain projects in-house after reviewing the relevant publications, or you may decide to enlist the help of professionals.



ENERGY STAR for Small Business
6202J
1200 Pennsylvania Avenue, NW
Washington, D.C. 20460
1-888 STAR YES
www.energystar.gov

Regardless, ENERGY STAR will help you become a smarter buyer through ENERGY STAR performance labeled products and free, unbiased technical support.

If you have access to the World Wide Web, we invite you to visit the ENERGY STAR for small business Web site at www.energystar.gov. From there, you can explore the success stories, technical information, “tools” and services, as well as links to other energy-efficiency sites throughout the Internet.

ENERGY STAR for small business is part of the overarching ENERGY STAR program family, which works with many different facets of the home and workplace. Here is a list of the other ENERGY STAR offerings you may want to explore in the future:

ENERGY STAR for small business for firms of 100,000 total square feet or less; call 1-888 STAR YES, or visit www.energystar.gov

ENERGY STAR for businesses greater than 100,000 square feet; call 1-888 STAR YES, or visit www.energystar.gov

ENERGY STAR Service and Product Provider Directory for companies involved in the energy efficiency business, including Rebuild America Business Partners; visit www.energystar.gov

ENERGY STAR “store finder” directory of retailers that sell ENERGY STAR labeled products; call 1-888 STAR YES, or visit www.energystar.gov

ENERGY STAR-labeled products for companies that sell or use computers, copiers, and other office equipment; call 1-888 STAR YES, or visit www.energystar.gov/products

ENERGY STAR Homes for home builders, home buyers, and home-owners interested in greater efficiency; call 1-888 STAR YES, or visit www.energystar.gov



Rebuild America
U.S. Department of Energy
1000 Independence Ave., S.W.
Washington, D.C. 20585
1-800-DOE-3732
www.rebuild.org

About Rebuild America

The U.S. Department of Energy’s Rebuild America program is a network of community partnerships made up of local and state governments, schools, universities, housing agencies, and private businesses that save money by saving energy. These voluntary partnerships, working with support provided through the Department, choose the best ways to plan and implement energy efficiency projects in the commercial, institutional, and multifamily residential buildings controlled by their partners.

Partnerships have access to products, services, and peer experiences on buildings, energy, finance, and more. Rebuild America provides support nationally and leads by regional teams. It assigns a program representative to each partnership to help in identifying local resources, financing options, and accessing special services from Rebuild America to aid in completing upgrades to effectively use the performance contracting option, working with the National Association of Energy Service Companies for accreditation of ESCOs, and monitoring the impacts of utility restructuring on investment options.

Rebuild America Financial Services aids access to capital by pointing partnerships toward programs offered by states, associations, or private financing organizations that may be able to provide investment capital at the lowest possible rates.

About the National Main Street Center

The National Main Street Center is part of the National Trust for Historic Preservation. The Trust created the Main Street Approach to downtown revitalization, and promotes the use of the approach to communities to revitalize their traditional commercial areas. It serves as the nation's clearinghouse for information, technical assistance, research, and advocacy on preservation-based commercial district revitalization. The National Main Street Center's mission is to empower people, organizations, and communities to achieve ongoing downtown and neighborhood district revitalization based upon the principles of self-determination, resource conservation, and incremental transformation represented in the comprehensive Main Street Approach. The National Main Street Center's prime focus is to:

- Provide direct, on-site technical assistance to towns, cities, and urban neighborhoods.
- Publish a wide range of training materials (<http://www.mainst.org/bookstore/bkmain.htm>).
- Offer membership in the National Main Street Network, which includes Main Street News.
- Sponsor an annual conference, the National Town Meeting on Main Street.
- Offer a professional certification program, the Main Street Certification in Professional Downtown Management.
- Organize the Great American Main Street Awards annual competition.



National Trust Main Street Center
1785 Massachusetts Avenue, N.W.
Washington, D.C. 20036
202-588-6219
www.mainst.org

Welcome

When you pay your electric bill or gas bill each month, you probably don't care too much about kilowatt-hours or therms. Whether you own your own building or are a tenant, you want light, hot water, air-conditioning, and other services at the lowest possible cost. *The ENERGY STAR® Guide for Small Business* can help you get the most from your equipment and facility, and even help increase your profits. This is energy productivity; it is comparable to employee productivity.

In the "energy crisis" of the 1970s, conservation meant being colder in the winter and hotter in the summer. Saving energy meant sacrifice of comfort. Since then there have been tremendous advances in equipment, appliance, and product technology such as building systems and controls, and office equipment. As a result you can get reliable, affordable "off-the-shelf" technologies that provide higher comfort, and higher quality business space for significantly less than you are currently spending.

Let's Look at Some Examples

Imagine a warehouse area that you just can't keep warm in the winter. Replacing the natural gas unit heaters with gas-fired radiant heaters can reduce your fuel use by 30 percent while keeping your employees comfortable so they can do their best work.

Say you have some incandescent floodlights mounted outside your building for security. Replacing this lighting equivalent with high-pressure sodium fixtures could save 80 percent

of the electricity while increasing the light level (see page 44). That can save you big money. In addition, installing photocell controls will ensure that the lights will always be off during the day and on at night to deter vandals or burglars who may be lurking in the shadows.

Have you experienced eye fatigue or headaches from working under the flickering glare of older fluorescent lights? Do you have trouble viewing your computer monitor because the lighting in the room is too bright? Upgrading your existing lighting with newer products can increase visual comfort and allow you and your employees to get more work done while you spend 20 to 50 percent less on energy than with old equipment.

The ENERGY STAR for small business program will help you apply solutions such as these to your business so you can save money, optimize energy use, and help protect the environment. As a partner in ENERGY STAR for small business, you have access to unbiased information on building technologies and the upgrade process.

For more information, call us toll free at 1-888-STAR YES or visit our Web site at www.energystar.gov.

Where To Find What You Need in This Guide

We realize your time is critical to your business, so we've designed this guide to get you the information you need quickly. This section is your key to finding information in this guide.

Section 1, Getting the Job Done, gives you practical advice on how to

overcome the technical, financial, and managerial hurdles that you may encounter on the path to improving your bottom line through energy efficiency. In this section, we give you proven strategies to identify the best energy upgrades for your business. We also discuss how you can finance these upgrades, and we give you time-tested guidelines for selecting contractors to help you get the job done.

Section 2, Technical Support, describes the many technologies that can improve your energy efficiency. You probably expect that lighting, heating, cooling, and water heating are covered in depth; however, you may be a little surprised to find out how much money selecting the right office equipment can save. And we include a discussion of techniques to optimize your paper use that will save you money while preserving our nation's forests and landfill capacity.

Throughout Section 2 we identify simple measures that you can do yourself in just a few minutes. And for the more involved upgrades, we explain the solutions and the terms so that you can be a smarter shopper when interacting with contractors and suppliers.

Section 3, Supporting Material, contains a glossary that will help you understand unfamiliar terms and new technologies. There are tables you can use to compare your energy use and costs with similar businesses in your region. This section also has a checklist of ways to improve your facility's energy efficiency and a shopping list of things to look for when buying or leasing a building. We make celebrating your success easy with a card at the end of this guide that you can use to describe your upgrade projects. Your facility may be featured in an ENERGY STAR success story, and your company can be publicly recognized for exemplary environmental responsibility in addition to good business practices.

Selected Reading

I've got no time.

Read "Finding the Time" and "Learning About Energy Efficiency" in Section 1. A consultant from one of the programs will be able to identify upgrade options for you with only a limited investment of your time.

I have access to in-house technical help.

Read Section 1 and then pass this guide to your in-house staff. One week later, schedule a meeting to review the technologies and upgrades that might be appropriate for your business, and establish a preliminary timeline.

I don't have technical staff and would likely contract out all work.

Read "Selecting a Contractor" in Section 1, then scan through this entire guide so you can determine which equipment to focus on and who to call for help.

Contents

Putting Energy Into Profits: ENERGY STAR® Guide for Small Business

SECTION 1: Getting the Job Done	1
Finding the Time	3
Finding the Funding	5
Learning About Energy Efficiency	7
Making a Good Building Even Better	11
Selecting a Contractor	15
Profiting From Energy Savings as a Tenant	19
Verifying Savings	21
ENERGY STAR® for Small Business	23
SECTION 2: Technical Support	25
Financial Analysis	27
Prioritizing Your Projects	31
Lighting Part I: Concepts	33
Lighting Part II: Upgrades	39
Building Tune-Up	49
Office Equipment	51
Paper	55
Water Heaters and Water Use	57
Refrigeration	63
Building Construction	65
Heating and Cooling	71
Other Ideas for Energy Optimization	79
SECTION 3: Supporting Material	87
Glossary	89
Free Publications and Programs	96
Average Energy Use and Costs Throughout the United States	97
Index	99
Energy-Efficiency Quicklist	103
ENERGY STAR® for Small Business Building Shopping List	105



Getting the Job Done

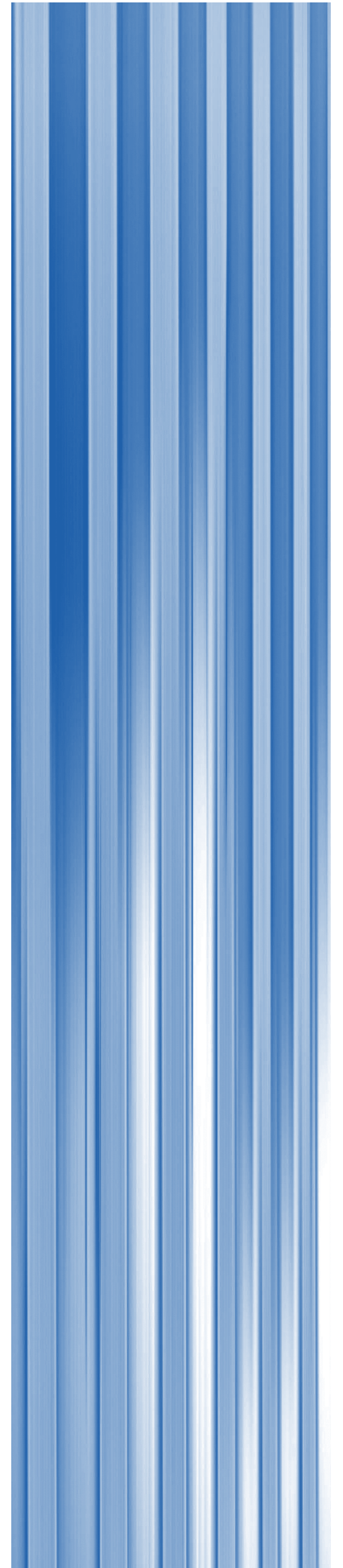

Finding the Time

We understand how important your time is to your business. We're also convinced that energy-efficiency upgrades are well worth your consideration due to the savings and improved comfort they bring.

Getting Started With Few Hassles

Here are strategies to jump-start your energy savings with a limited investment of your time.

- Ask your utility if they offer free or inexpensive energy audits.
- Invite lighting contractors and heating, ventilating, and air-conditioning (HVAC) contractors to your facility to suggest upgrades and provide free estimates.
- Leverage your time by drawing on the expertise of ENERGY STAR® and Rebuild America Products and Services providers by visiting their Web sites:
www.epa.gov/smallbiz/map.html.
www.rebuild.org/business/business.asp.
- Contract with an energy professional to coordinate and manage your project.
- Select turnkey services from an Energy Services Company (ESCO); see page 8.

- Unload responsibilities onto energy professionals when you discover a particular project is taking more of your time than you can afford.

The Cost of Delay

While we often think of upgrade projects in terms of how quickly the investment is paid off through the savings, we don't usually recognize the other side of this equation. For each month or year that you delay your upgrade projects, you completely lose that potential savings forever.

Consider a business with annual energy costs of \$25,000. If a comprehensive upgrade program could reduce energy use by 30 percent, this business could save \$7,500 per year.

Assume that the cost of implementing these measures results in a 3-year simple payback, which is typical. In delaying the upgrade, this business is forfeiting a low-risk investment opportunity at 27 percent interest.

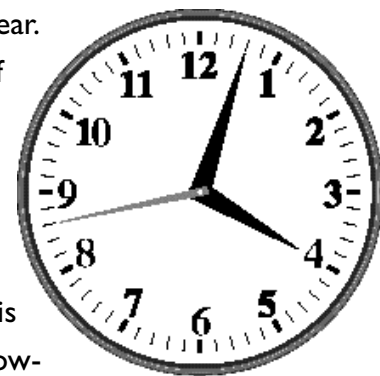

Success Stories

ENERGY STAR publishes “success stories” on actual small business efficiency upgrades online at www.epa.gov/smallbiz. The stories are designed not only to recognize a “job well done” by the small business and its contractors, but to also show other small businesses what equipment, appliances, and strategies are commonly most effective. You will find businesses like yours that have overcome the same obstacles you are facing to achieve bottom line dollar savings, while improving the quality and comfort of their facilities.

There is no substitute for a comprehensive energy survey and analysis of all your firm’s energy-efficiency options, but if you “don’t do anything else” here are some simple, high “return on investment” equipment upgrades. These 12 “sure savers” include, 1) turn off lights and equipment when not in use; 2) buy ENERGY STAR labeled products; 3) install lighting occupant sensors in proper locations; 4) adjust lighting to actual needs — use free “daylighting”; 5) tune-up HVAC system with annual maintenance contract; 6) regularly change or clean HVAC filters; 7) install a program-mable HVAC thermostat; 8) replace incandescent light bulbs with compact fluorescent lamps (CFLs), wherever appropriate; 9) install LED (light-emitting diode) exit signs; 10) control direct sun through windows; 11) use fans; and 12) plug air leaks with weatherstripping and caulking.

Again, we encourage that your business have a comprehensive, professional energy audit or survey, that will assess all your energy uses, then propose a prioritized (by cost/benefit) list of upgrade investments. Your utility company may offer such services at no cost, or you can find firms that offer such services with the help of ENERGY STAR. To read success stories on real small businesses energy savings, or to find finance, products, and services for your own energy efficiency upgrade, visit <http://www.epa.gov/smallbiz/map.html>.

Throughout this guide, you will find brief excerpts from ENERGY STAR small business success stories. If your small business has done a great efficiency upgrade, or you are a contractor with a successful client efficiency upgrade, you can submit a success story and even apply for an ENERGY STAR award at www.energystar.gov.

Finding the Funding

The key issue is, how do you pay for the upgrades? Not a problem. Energy-efficiency upgrades make such good business sense that there are many traditional and non-traditional financial resources to use in funding that can provide you with a positive cash flow for your business.

For inexpensive projects, you'll want to fund your upgrades from your own internal funds. This is the best way to keep payback time low and return on investment high. The overhead costs of financing are too high for small projects.

For larger jobs, small businesses often don't have the convenient cash reserves or revolving credit plans that large corporations do. Cash flow limitations can make capital funding from reserves simply impossible. In such situations, financing is the only way the project can be implemented. Fortunately, a wide variety of sources and mechanisms has evolved over the past few years to help small businesses maintain a positive cash flow while implementing energy-efficiency projects.

ENERGY STAR for small business Web Site

Resources are available through the ENERGY STAR for small business program to help you find financing. ENERGY STAR does not endorse individual lenders, but we provide a growing list of small business lenders. If you have Internet access, the Web site at www.energystar.gov features the "Finance Directory" (just click on "Find Money"), which provides lender,

vender, and utility resources, many with direct Web links. If you do not have Internet access, call us at 1-888 STAR YES, and our "tech support" staff will check your area for financing information.

Conventional Loan Sources

Conventional loans are a common financing option for many energy projects. Several different sources for these loans are listed below.

Small Business Administration loans. Your business banker can use the Small Business Administration's (SBA's) 7A loan guaranty programs to back loans for energy-efficiency projects. Here are descriptions of some of the loans SBA offers:

MicroLoans. The MicroLoan program

The ENERGY STAR for small business Web site is a quick avenue to locate financial resources and products and services for you to take advantage of: www.epa.gov/smallbiz.

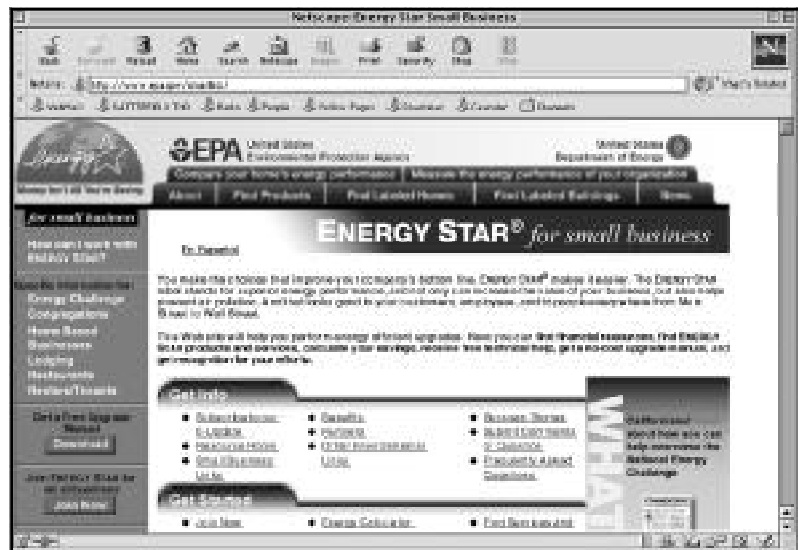

The ENERGY STAR for small business Finance Directory is available on-line, with direct links to participating lenders. Alternatively, you can call the toll-free hotline at 1-888-STAR YES to request the list for your area; or visit www.epa.gov/smallbiz/map.html.

Legislation in the summer of 1996 extended the ability of businesses to deduct equipment upgrades as an expense.

Savings Implications

If you borrow money to pay for energy-saving measures, keep two considerations in mind. First, you may want to arrange the loan period to be long enough so that you realize a positive cash flow each month. That is, if you implement a \$4,000 measure that saves \$1,200 per year (\$100 per month), then you could arrange a loan that pays back the \$4,000 at a rate of less than \$100 per month. This way your business will always see a positive cash flow for the measure. This cash flow will be smaller while you're paying off the loan but will increase dramatically once the loan is paid off.

Second, financing your upgrades with a loan will slightly extend your payback period and reduce your internal rate of return. Be sure to incorporate this factor into your business analysis.

provides small loans ranging from \$100 to \$25,000. Completed applications are usually processed within a week.

SBAExpress Loans. This program provides a guaranty on small business loans of up to \$150,000 within 36 hours of receiving the completed loan application package.

CAPLines Loans. Under this program, small businesses unable to meet traditional credit standards can get a revolving line of credit up to \$750,000.

To find out more, call SBA at 1-800-8-ASK SBA or see their Web site at www.sba.gov for more information.

Supplier Loans. Many suppliers offer financing in combination with installation of their equipment. You'll want to make sure the interest rate is comparable to what you can get elsewhere. See "Products and Services" at www.energystar.gov.

Utility Loans. Your local utility may have a low-interest loan program or rebates to underwrite energy-efficiency projects.

Finally, your state energy office may be aware of alternative sources of grant monies and loans.

Performance Contracting

Financing your project yourself through a cash purchase or a loan requires you to shoulder all the responsibility for the project's success. Performance contracting, available primarily through Energy Services Companies (see page 8), is an alternative way to finance energy-efficiency projects. You receive a lower level of cost savings at first but have assurance that your actual savings will meet your expectations.

Performance contracts are typically negotiated with no up-front cost to the building owner, and all project expenses are paid for by the energy savings. A detailed explanation of performance contracts is found in *Financing Your Energy-Efficiency Upgrade*, EPA 430-B-97-003. Call the ENERGY STAR hotline at 1-888-STAR YES for this or other publications.

Reinvestment of Savings

The ENERGY STAR program emphasizes a staged approach to energy investment projects (see page 32). Part of the reason for this is technical, but another part is that you can use the cost savings from your first project to fund your second project, your third project, and so on.

Tax Implications

Legislation in the summer of 1996 extended the ability of businesses to deduct equipment upgrades as an expense. This can save you money by taking capital costs that normally would be amortized and deducted from declared profit over several years and advancing the costs into a current year tax deduction. We suggest that you contact your accountant for more information on how upgrade projects can reduce your taxes and improve your cash flow.

Learning About Energy Efficiency

If you're like most small business operators, you know a lot more about running your business than about the intricacies of motors, lighting, or air conditioning. We understand you may be reluctant to take on the challenges of building upgrade projects, especially when your existing equipment still works. We will help you successfully implement up-grades by relying heavily on energy professionals and ENERGY STAR resources. ENERGY STAR will help you through the process, and we can answer your most difficult questions.

Energy-Efficiency Basics

Building technologies have been advancing at a striking pace over the past decade. It is now possible to perform upgrades that reduce energy use by up to 50 percent in some cases. If your building's lighting and heating/cooling systems are more than 10 years old, you could potentially see big savings by upgrading them. Some of the key opportunities are described below.

Lighting. Even though the light bulb is still the symbol of innovation, old incandescent bulbs consume 75 percent more electricity than compact fluorescent bulbs. There are also new technologies to reduce the energy use of fluorescent fixtures. And occupancy sensors, which turn lights off in unoccupied areas, have become surprisingly inexpensive (see page 45). Look around your building. If you use just about any fixtures that are more than 10 years old, your building is a good candidate for a lighting upgrade.

Building Tune-Up. Get your building back to its peak performance. See page 49 for more information.

Office Equipment and Paper Use. Selecting ENERGY STAR equipment when you purchase new computers or office equipment and encouraging a few simple practices among your employees will yield energy savings with absolutely no investment cost. See pages 51–53 for more information.

Consider Some of the Traditional Myths About Equipment and Energy Use

Myth: *Leaving computers on helps them last longer.*

Reality: Today's computers do not suffer from being turned on and off thousands of times. In fact, turning computers off when they're not being used lowers the amount of dust buildup inside, which helps them last longer while saving you money.

Myth: *Energy costs are an insignificant part of total expenses.*

Reality: Typical restaurateurs and grocers spend as much on energy as they earn in total profits. Furthermore, improved employee comfort and productivity (which are common after building upgrades) can lead to much greater profit than is indicated by your reduced utility bills.¹

Myth: *Fluorescent lights last longer if not turned on and off.*

Reality: Switching fluorescent lights on and off does slightly shorten their life. However, any time the lights will not be needed for more than about 10 minutes, you save more money by turning them off than by leaving them on.

Myth: *I should replace old equipment with more efficient versions only as the old systems break.*

Reality: With some new technologies, such as T-8 fluorescent lights (20 to 60 percent savings) or light-emitting diode (LED) exit signs (up to 90 percent savings), there's just no reason to wait. You can start saving money on energy and maintenance costs right away.

¹ American Society of Heating, Refrigeration and Air-Conditioning Engineers Journal, January, 1997.

Unique opportunities for energy savings are available for each business.

Water Heating and Water Conservation. You may be paying more than you have to for water use or water heating. Learn more starting on page 57.

Refrigeration. Check your seals regularly and specify high-efficiency evaporator fans when you buy new systems. These and other operations and maintenance guidelines will keep your refrigeration equipment working at peak efficiency. See page 63 for additional ideas.

Building Construction. Starting on page 65 is a review of the steps to upgrade your building's walls, roof, and windows to get the most comfort from your heating and cooling units.

Heating and Cooling. Inexpensive modifications such as installing programmable thermostats and cleaning your filters can often significantly reduce your heating or cooling costs. Thinking of replacing your old system? See page 71 to explore the options before you buy, because it may be worth a little extra to buy a high-efficiency unit. If your existing system is old enough, it may be cost effective to replace it with a new one immediately.

Other Opportunities. Each business has unique opportunities for energy savings based on the particular equipment it uses or the processes that occur. Many of these measures are discussed starting on page 79. You can also call the ENERGY STAR hotline at 1-888-STAR YES for information on measures not covered in this guide.

Installation Support

Lean on outside contractors for expertise and installation. Available resources include ESCOs and conventional contractors:

- **Energy Services Companies (ESCOs)** offer turnkey services that are excellent alternatives for larger projects. The company will perform an audit (usually free) to identify savings opportunities and will arrange financing, coordinate contractors, and perform all project management. Often these projects are financed as performance contracts, where the ESCO receives a portion of the savings generated by the project. The National Association of Energy Services Companies (NAESCO) can refer you to the ESCOs in your area; call (202) 822-0950 or visit the Web site at www.naesco.org.
- **Lighting contractors** will be familiar with all aspects of lighting design and can conduct lighting audits, recommend replacements, and calculate energy and cost savings. Lighting contractors are the best choice when the project is high profile or requires significant lighting redesign.
- **Electrical contractors** have skills installing motors, modifying equipment, and performing straightforward lighting upgrades.
- **Mechanical contractors** specialize in the heating, cooling, and ventilating systems at a facility. They can coordinate the work of subcontractors and interface with installers of Energy Management Systems (EMSs) if required.
- **Controls contractors** specialize in the automatic controls for heating, cooling, ventilating, lighting, and emergency systems. Installation of a central computerized control system with advanced energy savings functions (also known as EMS) is cost effective for many facilities.
- **Operations and maintenance contractors** will perform routine preventive maintenance and improve equipment operating schedules that can extend equipment life and reduce energy use.

Look to Experts for Advice

The type of help you will need to start your upgrade projects depends on the amount and skill level of in-house support, the type of project, project size, and how the project will be financed. To begin, you may need the help of a consultant or an energy auditor to identify upgrade opportunities. If your in-house support is extremely limited, you may need some level of management or oversight by a consultant other than the contractor performing the work. Typically this is money well spent, because just like hiring a professional accountant to prepare your tax returns, professional consultants or auditors often save you more money and provide fast and efficient results that allow you to make knowledgeable choices concerning energy-efficiency upgrades.

Start with a free energy audit where available. First call your electric or gas utility. Almost half of the country's biggest utility companies offer free or subsidized energy audits for commercial customers to identify energy-

efficiency opportunities. These audits may not identify too many fuel-switching opportunities that convert you from the sponsoring utility's product, but they are an excellent and objective way to get started. Some utilities give out compact fluorescent lamps for free to their customers. If you don't have any luck there, you can sometimes call your electrical or heating, ventilating, and air-conditioning (HVAC) contractors for free walk-through audits. Just recognize that the contractor's agenda for such an audit will include a sales pitch; if you don't have a long-term relationship with your contractor, you will want to carefully consider capital-intensive recommendations. If you don't have a contractor, call 1-888-STAR YES and ask for your nearest ENERGY STAR buildings partner. ENERGY STAR buildings partners have received training in strategies to upgrade building systems to optimize performance.

For large projects outside your realm of expertise, consider hiring consultants to prepare bid documents or to verify the work of contractors. For more information see page 15. As a rule of thumb, it is worthwhile to have a management investment of 3 percent to 10 percent of the project cost so an independent expert can oversee major projects. This premium doesn't detract much from your payback and is a good insurance policy. Look in the yellow pages of your phone book under "engineering consultants," or similar titles, or call 1-888-STAR YES for the name of your nearest ENERGY STAR buildings partner.

For information on financial or technical assistance contact your local small business development center or visit <http://www.asbdc-us.org/> for a list, or call the Small Business Administration at 1-800-8-ASK SBA. You can also contact your state energy office or ask your local Chamber of Commerce.

Where Can I Learn More?

For more information on energy technologies and audit capabilities, contact:

- Air Conditioning Contractors of America (ACCA): (301) 384-2222
- American Consulting Engineers Council (ACEC): (202) 347-7474
- American Society of Heating, Refrigeration, and Air-Conditioning Engineers (ASHRAE): 1-800-527-4723 or (404) 636-8400; www.ashrae.org
- American Society of Mechanical Engineers (ASME): 1-800-THE-ASME or (301) 937-2799; www.asme.org
- American Solar Energy Society (ASES): (303) 443-3130; www.ases.org
- Association of Energy Engineers (AEE): (770) 447-5083, ext. 220; www.aeecenter.org
- The Association of Energy Service Professionals (AESP): (407) 361-0023
- Association of Small Business Development Centers (ASBDC): (703) 764-9850; info@asbdc-us.org
- Center for Renewable Energy and Sustainable Technologies (CREST): 1-888-44CREST; www.solstice.crest.org/
- Electric Power Research Institute (EPRI): www.epri.com
- The Energy-Efficiency and Renewable Energy Clearinghouse (EREC): 1-800-313-3774 or (650) 855-2000; www.eren.doe.gov
- ENERGY STAR for Small Business Hotline: 1-888-STAR YES; www.energystar.gov
- Energy User News: (248) 362-3700; www.energyusernews.com
- Lighting Research Center: (518) 687-7100; www.lrc.rpi.edu
- National Association of Energy Services Companies (NAESCO): (202) 822-0950; www.naesco.org
- National Trust Main Street Center: (202) 588-6219; www.mainst.org
- National Society of Professional Engineers (NSPE): (703) 684-2800; www.nspe.org
- Rebuild America: 1-800-DOE-3732; www.rebuild.org

Look in the yellow pages of your phone book under engineering consultants, or similar titles, or call 1-888-STARYES. Online, visit the map-based directory of finance, products, and services at www.epa.gov/smallbiz/map.html or visit the Rebuild America Business Partners page at www.rebuild.org/business/business.asp.

Success Stories

Subway Franchises Make Bread of Another Kind

Twenty thousand dollars can buy a lot of bread. That's what Subway franchise owner Steve Kaplan is saving by installing energy-efficient equipment, including lighting, in seven Subway locations in Oklahoma. With these improvements he reduced his energy costs by 40 percent and made his restaurants more attractive and comfortable for customers. In addition to properly lighting his restaurants, Kaplan makes his energy-efficient equipment upgrades where he will get a 3-year payback or better. Because Kaplan leases the space for all seven of his Subway franchises, he upgrades only when he plans to renew a lease that is at least three to five years in length.



Just the Right Light to Whet Your Appetite

Kaplan changed his stores' lighting from 40-watt T-12 lamps with magnetic ballasts to 32-watt T-8 lamps with electronic ballasts and reflectors. "After I installed the energy-efficient lighting," he said, "my customers said the produce looked fresher and more appealing" thanks to the better color-rendering of the T-8 lamps he installed. Subway franchises are required to have a high light level, and Kaplan's lighting upgrades maintain this very bright level even though each fixture was reduced from four bulbs to two.

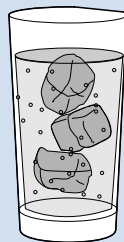

Cool as a Cucumber Sandwich

The store's kitchen equipment generates so much heat that the air conditioning runs year-round. Ice makers are one of the main heat sources. To reduce his air-conditioning costs, Kaplan has invested in water-cooled condensers for ice makers in some of his stores so the heat from the ice makers goes into the water instead of the room. His choice of stores depends on whether

his water or electricity utility costs are higher in the area. For the future he's looking into buying ice makers that have separate condensers so the heat from the ice makers can be sent straight outside.

Customer Comfort Comes First

Kaplan wants his stores to be inviting year-round with plenty of air-conditioning capacity, so whenever he opens a new store he replaces the old air conditioner with a high-efficiency unit. The units run year-round so paying a premium for high-efficiency units is well worth it for him. To keep his costs down, he also installs ceiling fans. They add to the ambiance, and the slight breeze they provide allows him to set his air conditioner three to five degrees higher without any sacrifice in comfort. This saves him money too.

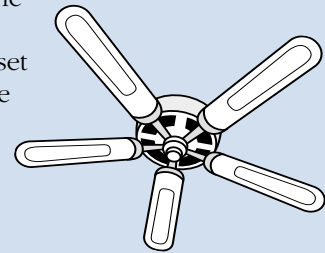

Upgrades are Piled High With All the Trimmings

Kaplan has switched from electric to gas water heaters with just a 1-year payback on the installation thanks to the low cost of gas, even including the cost to build a special fire-retardant closet and install a roof vent. His windows are all tinted to keep out heat from the sun. Maintenance is an inexpensive way to save money, and Kaplan takes advantage by regularly inspecting his refrigerator and freezer door gaskets.

Rolling in the Dough

Overall, Kaplan saves \$20,000 per year from his upgrades. The upgrades also make his food look more appealing and keep his customers more comfortable. Participation in the ENERGY STAR program helped Kaplan make the right decisions and gave him free publicity. That's smart business.

Making a Good Building Even Better

ENERGY STAR partners have reduced their buildings' energy costs by an average of about 30 percent, and upgrades at these sites continue. But even if your building is already relatively energy efficient, almost every commercial building can have its energy costs reduced by at least 10 percent with measures that pay for themselves in less than three years. Energy cost reduction of 50 percent or more will be economically profitable at some sites.

The best way to measure your energy use is by calculating it per square foot and comparing it with other buildings that conduct the same type of business that you do. Fill out the worksheet on page 12.

Once you have calculated your electric energy intensity, look at the pie charts on pages 13 and 14. The charts show the national average of typical annual energy use by building type for all-electric buildings. The pie pieces are sized according to total energy use and are labeled according to equipment type. Certainly an office in Miami, FL, will use more energy than the same type of office in downtown San Francisco, CA, so be sure to consider heating and cooling variations in your comparison.

Keep in mind that the values on pages 13 and 14 are averages. An "average" business will typically have profitable opportunities to lower its bills by 30 percent. A business using more than the average amount of electricity may have even better opportunities. Even a business significantly below the average can usually find potential savings through measures that emphasize the newest technologies (such as

ENERGY STAR office equipment).

To find the best upgrades for your building and equipment, you will want to identify the area of your highest energy use. The best place to start is to review your electric, natural gas, fuel oil, and other energy bills for the past year. Select your highest bill. Is it highest in the summer? This probably indicates high air-conditioning costs. Is it highest in the winter? If you currently have electric resistance heat, you may save money by converting to natural gas, fuel oil, or an electric heat pump. Are your electric bills higher in spring and fall than in summer and winter? Simple modifications to your heating and cooling systems may provide excellent savings.

Many times you will discover that your peak electricity use occurs during a time of year when rates are highest. In addition, your electric bills may have a demand charge component, which is a charge based on your peak rate of electricity use. These factors make it especially important to select energy-efficiency upgrades that will lower your energy use when the utility's rates are at their highest or when your facility's demand is at its peak.

ENERGY STAR partners have reduced their buildings' energy costs by an average of about 30 percent.

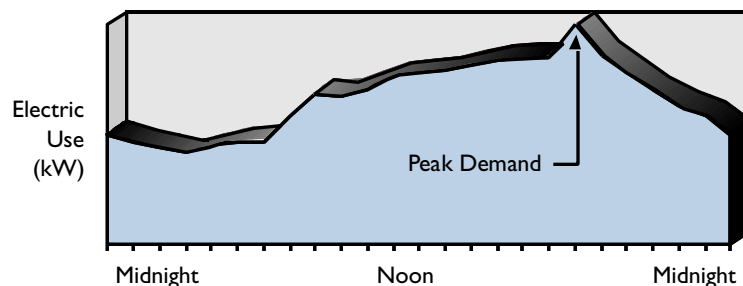

If you are charged a "demand charge" on your electric bill, you pay a fee based on your peak rate of electricity consumption. Lowering your peak rate of usage can save big.

How Efficient Are You?

Use this worksheet to compute your electric energy intensity, or visit www.epa.gov/smallbiz/calculate.html.

1. Look through a few of your electric bills, including winter, spring, fall, and summer months if possible. Write the average kilowatt-hour (kWh) per month on line (A). (A) _____ kWh/month
2. Multiply (A) by 12 to compute your approximate annual electricity use. Write this number on line (B). (B) _____ kWh/year
3. On line (C), write down the size of your facility in square feet. (C) _____ square feet
4. Calculate your **electric energy intensity** by dividing (B) by (C) to get the overall kWh per square foot per year. Write this number on line (D). (D) _____ kWh/sq.ft./year
5. Compare the number on line (D) with the results of similar businesses around the country (your competitors) so you can find out where you stand in relation to your peers. See the pie charts on the next two pages.

The **electric energy intensity** you just calculated does not include the fuel oil, natural gas, purchased steam, or propane your business may use. If you would like to compare your *total* energy use and costs with similar businesses in your climate region, see *Average Energy Use and Costs Throughout the United States* on page 95.

Using Utility Bills To Forecast Upgrade Costs

You can use your current utility bills to estimate the total cost of upgrades that may be cost effective. ENERGY STAR's experience with energy-efficiency upgrades has shown upgrade savings to be between 10 and 50 percent of existing utility bills. Because the typical upgrade costs three times what it saves in one year, you can anticipate an upgrade budget of roughly 100 to 150 percent of your total annual utility bills.

For example, if your annual utility bill is \$24,000 (for all fuels), it may be cost effective to anticipate spending \$24,000 to \$36,000 on upgrading your equipment. You can find information on financing these upgrades starting on page 27. This budget can be a good reality check once you start getting prices from suppliers and contractors. Of course, you may encounter savings higher or lower than this depending on your facility.

Compare Your Business With the National Averages

Your Business Type	Your Electric Energy Intensity (kWh/sq.ft./year)	National Average Electric Energy Intensity (kWh/sq.ft./year)	Typical Electric Energy Use
Warehouse	_____ Line (D) from worksheet on page 12	6.5	<p>Refrigeration 32% Heating 22% Cooling 16% Lights 12% Ventilation 7% Miscellaneous 5% Cooking 4% Water Heating 2%</p>
School	_____ Line (D) from worksheet on page 12	9.0	<p>Heating 40% Cooling 19% Lights 17% Water Heating 8% Ventilation 6% Miscellaneous 4% Refrigeration 2% Cooking 4%</p>
Lodging	_____ Line (D) from worksheet on page 12	15.3	<p>Heating 26% Cooling 22% Lights 16% Water Heating 14% Ventilation 5% Miscellaneous 5% Refrigeration 4% Cooking 8%</p>
Retail	_____ Line (D) from worksheet on page 12	15.3	<p>Cooling 27% Heating 19% Lights 26% Refrigeration 10% Ventilation 6% Miscellaneous 5% Cooking 3% Water Heating 4%</p>
Office	_____ Line (D) from worksheet on page 12	16.5	<p>Heating 24% Cooling 24% Lights 24% Ventilation 11% Miscellaneous 10% Refrigeration 1% Cooking 2% Water Heating 4%</p>

Compare Your Business With the National Averages (continued)

Your Business Type	Your Electric Energy Intensity (kWh/sq.ft./year)	National Average Electric Energy Intensity (kWh/sq.ft./year)	Typical Electric Energy Use
<p>College</p>	<p>_____ Line (D) from worksheet on page 12</p>	<p>18.6</p>	
<p>Health</p>	<p>_____ Line (D) from worksheet on page 12</p>	<p>22.3</p>	
<p>Restaurant</p>	<p>_____ Line (D) from worksheet on page 12</p>	<p>43.4</p>	
<p>Grocery</p>	<p>_____ Line (D) from worksheet on page 12</p>	<p>52.5</p>	
<p>Miscellaneous</p>	<p>_____ Line (D) from worksheet on page 12</p>	<p>12.3</p>	

Note: Pie charts reflect proportions for typical all-electric buildings. Data aggregated from the Electric Power Research Institute's *COMMEND User's Manual*, U.S. Department of Energy's *Commercial Building Energy Consumption Survey*, and Aspen Systems Corporation research data.

Selecting a Contractor

Your selection of contractors and other energy professionals will have a strong bearing on the success of your upgrade program. Some contractors may recommend upgrades that are less than optimum due to either a hidden sales agenda or limited experience with other technologies.

Resources Through ENERGY STAR, Rebuild America, and The National Main Street Center

Selecting contractors and other professionals who are affiliated with each of these national programs will help ensure that your job will be performed in accordance with the latest energy-efficiency technologies. Here is how you can contact specific organizations through each program:

ENERGY STAR: Visit the online directory of finance, products and services for your state at www.epa.gov/smallbiz/map.html.

Rebuild America: Visit the Rebuild America Business Partners Web site at www.rebuild.org/business/business.asp to search for experts in areas such as financing.

The National Main Street Center: Through the Main Street Network, you can tap into a comprehensive range of expertise, from commercial district revitalization to economic development to building, landscape, and district design. To find out more, visit

www.mainst.org/technical/technicalmain.htm.

All of these programs also sponsor regional workshops for businesses that provide the opportunity to learn how to get upgrades done or to network and exchange information on what has worked at their facilities.

Solicit Competitive Bids

For larger projects, an ENERGY STAR small business should issue a request for proposal (RFP) to get competitive bids that are all based on the same scope of work. Although this may seem like a costly process up front, it could save you a lot of money on design and construction costs in the long run. For smaller projects, it may not be cost effective to go through the RFP procedure; therefore, you'll need to rely more heavily on the interview and reference portions of this exercise (see page 17). The break-even point for issuing an RFP depends on project size, complexity, and whether in-house personnel are sufficiently skilled to prepare the RFP document. At the very least, you should get multiple bids on any large job.

The RFP structure depends on how much background work has already been completed on the project. If no preliminary work has been done on project development or design, a small business will need a more complete menu of services than might otherwise be the case. The RFP invites interested parties to visit the site and conduct

Any small business, anywhere can benefit from the California Energy Commission's "Handbooks for Energy Efficiency" series. Titles include "Energy Accounting," "How to Hire an Energy Services Company," and "How to Hire a Construction Manager For Your Energy Efficiency Projects." Visit http://www.energy.ca.gov/reports/efficiency_handbooks/index.html for more information.

A critical step in the success of a building upgrade project is the evaluation of proposals.

initial audits of the facilities to identify potential projects. Based on these initial audits, the contractors may submit details of projects that they have identified, including estimates of energy savings and cost savings, and a description of other benefits.

If a facility's energy audit identifies energy savings opportunities, the potential bidders can be provided with a copy of the completed audit. These contractors can then base their proposals on the information provided, or propose modified or alternative solutions that are more cost effective.

If a design has been completed on a specific energy measure, a small business can provide potential bidders with a set of the design drawings from which they can develop their installation cost proposal.

Evaluation of proposals is a critical step in the success of a building upgrade project. To compare proposals, especially those that contain different energy-saving strategies or specified equipment, a basic knowledge of the technologies is required. If this expertise is not available within a small business, an outside source such as an ENERGY STAR buildings partner or an

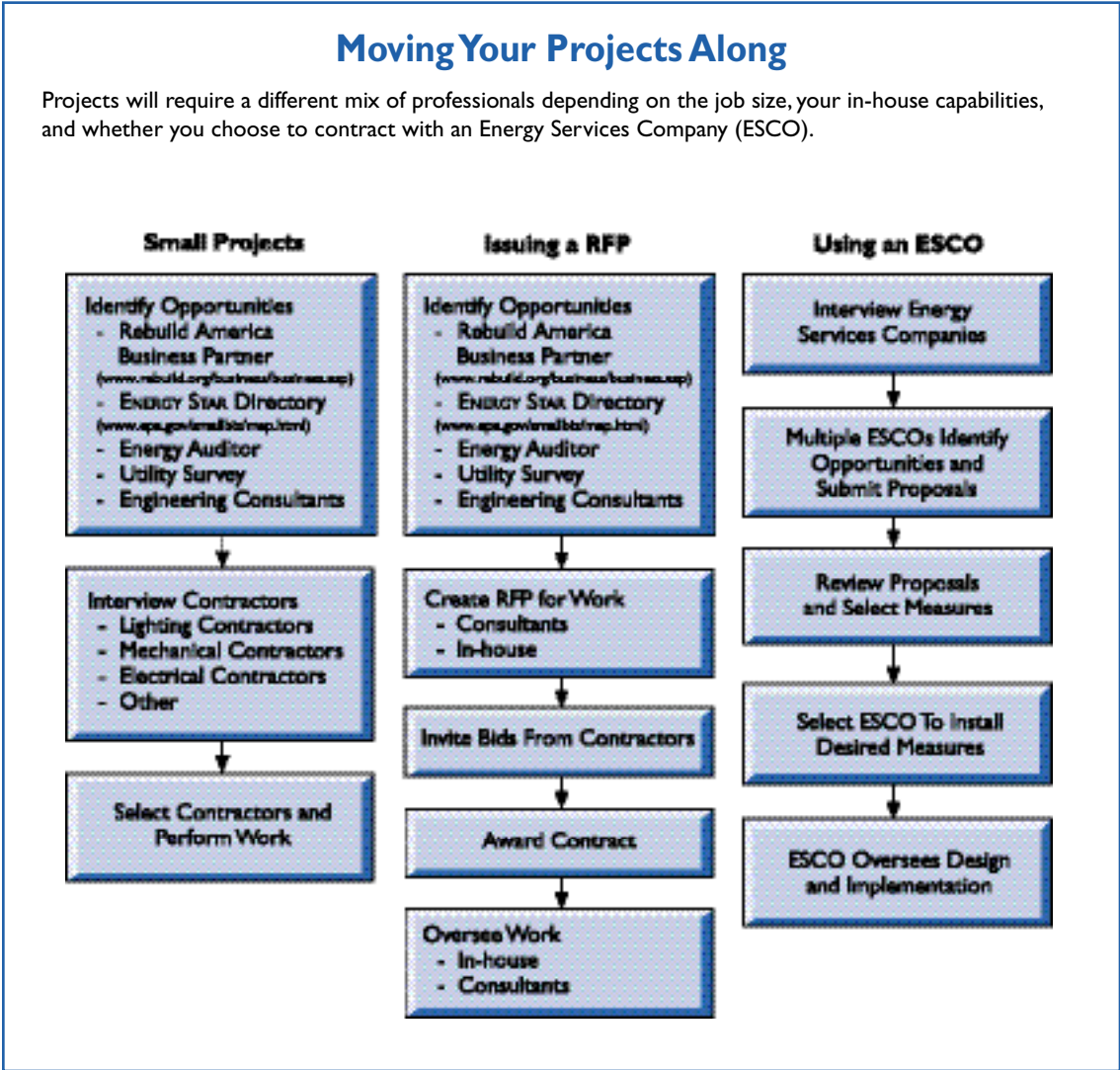

engineering consultant should be part of the selection process.

The following guidelines will assist you in selecting the best contractors for your job, regardless of whether or not you issue an RFP.

Interview Prospective Contractors

Contractors will be eager to discuss their capabilities and experience with you. Ask if they have worked on projects similar to yours. Discuss the type of work relationship that they like to establish. Get information on the complete scope of services available, including project management, consulting, verifying the work of others, operations and maintenance, arranging financing, filing utility rebate documentation, and so forth. Request information on the number of and experience of the engineers that would be assigned to your project, and check to see if they are affiliated with the relevant professional societies. Ask contractors if they received any awards or had their work featured in magazines or journals.

Check References

Obtain the phone numbers of three businesses where the contractors have performed work similar to your project. Call these businesses and ask if they are pleased with the contractor's work and how the contractor responded to any problems that occurred over the course of the project.

Manage Contractors

Detailed coordination while the project is under way will minimize the inconvenience to your staff, while allowing the contractor to perform a profitable, high-quality installation. Regular meetings with you, your contractor, and other relevant personnel are essential. Well-defined project stages, combined with interim payments, will serve as a mechanism of dialogue during the project. For example, 10 percent of the project cost can be due upon presentation and acceptance of the design drawings, 70 percent can be due as the work progresses, and the final 20 percent can be due after performance verification and staff training.

Settle Difficulties

Don't pay your final bill until you're satisfied with the work, and remember that as a consumer you have every right to satisfactory service. For big air-conditioning jobs, a revisit to tune up the system is not unusual. Reputable contractors often will make the extra effort to ensure that you're a satisfied customer.

In the unlikely event that serious problems do arise, consider binding arbitration. Binding arbitration has become common among the building trades because it offers fast resolution with little of the expense or unresponsiveness of the legal system. We recommend that you consider specifically citing the use of binding arbitration in your contracts.

Detailed coordination during the project minimizes the inconvenience to your staff and allows the contractor to perform a profitable, high-quality installation.

Profiting From Energy Savings as a Tenant

Whether the cost of utilities is billed directly to you by the utility companies or is included in the rent, all tenants ultimately pay to keep the building comfortable and well lit. Tenants are often disinclined to invest in the building itself, however, because they don't own the premises. This section describes strategies for reducing energy and rent costs for the 70 percent of small businesses that don't own their own space.

You Pay Your Utilities Directly

If you pay your own utility bills directly, any upgrade will be worthwhile if it meets your investment criteria and pays for itself before you expect to move. Because upgrades typically increase the value of the leased space, you may be able to get your landlord to subsidize the upgrade cost or decrease your monthly rent. The latter possibility makes a good energy-efficiency investment even better, and you may wind up with a better deal than if you owned your space.

In some leasing arrangements where the tenant pays the utility bills, the landlord marks up the cost of utilities with a handling fee of about 10 percent. If so, your incentive to reduce energy costs are higher than if you own the building because you can save even more.

Utility Costs Are Included in Your Lease

If you don't pay your own utility bills directly, ask your landlord if you can get a \$100 monthly rent reduction if you install new lights that use \$90 per

Success Stories

A Home Office in Bethesda, MD

A consulting engineer in Bethesda, MD, used a rented house as her office. When she first moved in, the house was cold and drafty and had exorbitant utility bills. To improve working conditions and save energy, she negotiated an arrangement with her landlord. The consultant and her husband purchased and installed attic insulation, new double-pane windows, top-quality indoor shades, new doors, and a programmable thermostat. The landlord reimbursed them for materials and also paid for their labor at 50 percent of the market rate. The improvements saved the consultant about \$50 per month during the summer and winter months and greatly increased comfort. Furthermore, the landlord reduced the consultant's rent by 20 percent, or \$200 per month, for one year after the renovations to compensate her for her efforts. The landlord benefited as well. He had a stable lease, and once the consultant did move out, he sold the house in only three weeks and made a profit of \$75,000. An estimated \$10,000 of that profit was due to the recent renovations.

	Costs	Benefits
The Tenant	Time to install upgrades	More comfort \$400/year lower gas and electric bills \$2,400/year lower rent
The Landlord	\$3,115 materials \$840 labor \$2,400 rent reduction	\$3,115 tax deduction \$840 free labor \$10,000 capital appreciation

Visit “Energy Efficiency and Tenants” at www.epa.gov/smallbiz/tenant.html, or ask for “small business tech support” at 1-888-STAR YES.

month less energy and increase the property’s market value. Your landlord just might say yes. Alternatively, your landlord might pay for the total cost of upgrade projects if she or he believes that the upgrades will extend the time that you remain in the space. Remind the landlord that capital improvements are often tax deductible.

Focus on No-Cost or Low-Cost Opportunities

Even given the rationale above, typical tenants will not be interested in investing \$20,000 in new windows for a building owned by someone else unless the investment is part of a larger marketing “image makeover.” Tenants are often best served by focusing on measures that require little capital and will help increase comfort. These measures can save tenants a surprising amount of money and are ideal for businesses that rent their facilities.

No-Cost Options

- Turn up or turn back thermostats during unoccupied times (consider installing a programmable thermostat; see page 72)
- Turn off lights and office equipment at night and over the weekend
- Take advantage of daylight
- Use e-mail instead of paper memos
- Disconnect unnecessary equipment such as unused freezers, water heaters, and transformers

Low-Cost Options

- Caulk and weather-strip windows and doors
- Replace light bulbs with more efficient ones
- Install occupancy sensors in areas such as conference rooms and storage rooms
- Install timers on electric water heaters or other equipment
- Install awnings or shades to keep out the summer sun and lower air-conditioning costs
- Fix leaking faucets, showerheads, pipes, or toilets

Focus on Savings You Can Take With You

ENERGY STAR office equipment represents a lasting investment in your business. If you buy an ENERGY STAR computer, fax machine, copier, or printer, the equipment stays with you even if you move so that your savings don’t depend on the length of your lease.



Marketing Adds Profits

Measures that may enhance your business, such as improving the lighting in key merchandise areas, are excellent opportunities. Promoting your business through the ENERGY STAR, Rebuild America, or Main Street programs may increase your visibility, and in turn, your sales.

Each of these programs proudly supports the small businesses of the country and can provide recognition to you. Each program offers many resources, such as display posters, articles, and publicity and events that focus on good community stewardship. The ENERGY STAR for small business Web site even has hypertext links so that visitors from all over the world can jump straight to your home page! Together, these efforts can give your business a large and positive presence in your community.

Refer Your Landlord to Us

Landlords also can benefit from participation in the ENERGY STAR for small business program or the ENERGY STAR buildings program. Have your landlord call the ENERGY STAR toll-free hotline at 1-888-STAR YES to discuss materials and programs specifically designed for property managers.

Verifying Savings

You can't see energy, so it can be hard to tell if an upgrade is a success. As a small business owner, you want to make sure that the money you invest in implementing energy-efficiency measures provides the anticipated savings on your utility bills. This section describes the features of successful programs and highlights principles you can apply to quantify savings.

Compare Before and After Utility Bills

Bill comparison provides you with a technique to quantify your savings after implementation of energy-efficient measures. Because so many different factors affect bills, this approach is most revealing when you have implemented major projects that should save you more than 10 percent. Simply add up your energy bills for the year prior to implementation of the measures and for the year after project completion. Subtract the 12 months of "after" from the 12 months of "before" and you will have your gross cost savings.

You will need to adjust the gross savings depending on differences in behavior and changes in energy prices and weather during the two years. For example, if your business expanded 20 percent over the course of the two years, then it is likely that your energy use increased as well. Take this into consideration. Many utility bills will include a statement about the number of "heating degree days" that occurred during the billing period. Bill analysis

should take into account yearly variations in weather. For example, during a very mild winter, your heating system might not be running at full capacity; therefore, energy savings associated with the heating system might not be obvious.

Spot Metering

Spot metering is particularly applicable for lighting upgrades. Ask your lighting contractor to turn on all the old lights that are to be replaced and then measure the current leaving the circuit breaker and leading to the fixtures for at least one circuit. After the upgrade is complete, measure the current for that same circuit. Then perform the following calculations:

1. Subtract the lower post-upgrade current from the higher pre-upgrade current.

Bill comparison lets you quantify your savings after you implement energy-efficient measures.

The Keys to a Successful Program

Your chances of truly lowering your costs will increase if you:

- Focus your upgrade projects on the areas of highest energy use for the facility.
- Focus on proven energy-efficiency technologies.
- Meter before and after the job is complete.
- "Commission" the project; that is, inspect and verify proper installation and operation.
- Use Rebuild America Business Partners (www.rebuild.org/business/business.html) or the ENERGY STAR Directory (www.epa.gov/smallbiz/map.html).
- Use internal or hired staff that have a track record of success.
- Hire a top-quality contractor.

To ensure the soundness of the project, measure the financial performance of your investment in energy-efficiency technologies.

2. Multiply the change in current by the voltage to get watts saved on the circuit.
3. Divide watts saved by the number of upgraded fixtures to get watts saved per fixture.
4. Compare the watts saved per fixture to your expectations and the supplier's quote.

Insist that the current measurement be done in your presence. This exercise will take less than 10 minutes and will give you a lot more confidence in the success of the project.

Extended Metering

Although installing additional meters to directly measure energy consumption is usually beyond the scope of energy-efficiency projects, innovative strategies may provide some of this information. For example, timers are installed on some equipment to facilitate scheduled maintenance. These timers can be recorded to verify the performance of energy savings measures that result in reduced equipment operation hours.

Some programmable thermostats are equipped with simple functions that estimate the hours of heating or cooling use; these could be used to test the effectiveness of insulation measures. Likewise, many Energy Management Systems (EMSs) contain sophisticated features for analysis of building energy use that can be used to verify predicted savings.

Benefits Beyond the Meter

Measuring the financial performance of your investment in energy-efficiency technologies is important to ensure the soundness of the project. The benefits of increased comfort and improved productivity may multiply your savings even though these benefits are typically difficult to measure. The favorable comments by employees and customers can offer an indication of the magnitude of this effect.

Success Stories

Thomas Mott Bed & Breakfast is a 4,200 sq.ft. facility in Alburg, VT. President Patrick Schallert indicates that the year before the upgrade, the inn spent \$9,362 on electricity; afterwards, the annual electricity bill was \$1,370 - nearly an \$8,000 decrease. How? The owners of the old farmhouse-turned-inn invested in wall space insulation, a state-of-the-art boiler, new windows and lights and switched the kitchen from electric to gas. They also planted trees to provide shade, which substantially lowered cooling costs in the summer. The trees also are an attractive asset.

Jose O'Shea's Café and Cantina in Lakewood, CO has installed energy-efficient lighting, an efficient HVAC system and improved insulation. The results can be seen and felt by the restaurant's customers, and the employees particularly appreciate the improved comfort and appearance. Jose O'Shea's General Manager, Jim Burns estimates energy savings of about \$11,000 annually, and the 157,143 kWh saved will prevent about 195,486 pounds of carbon dioxide emissions each year.

ENERGY STAR® for Small Business

ENERGY STAR is voluntary and easy, and it will help you save money. No reporting is required. We're here to help commercial and industrial energy users apply cost-effective and proven energy-efficiency technologies. Small businesses like yours will not only save money, they will also help lay the foundation for a cleaner planet for future generations.

The family of ENERGY STAR programs, encompassing buildings, homes, office equipment, appliances, and many other areas, aims to reduce pollution and protect our environment through application of energy-efficiency technologies. Making homes, businesses, and industry more energy efficient reduces pollution because utilities don't need to generate as much electricity. That means they aren't burning as much fossil fuel, and that in turn means they aren't releasing pollutants into the atmosphere.

What Happens If You Quit the Program

The only negative impacts are that your business will continue to pay more than necessary for energy and your pollution prevention contribution will be missed. Otherwise, there are no penalties. ENERGY STAR wants to help you succeed in saving money and preventing pollution, and as long as you are willing, we will work with you to make it happen. Your business may reap the rewards of lower costs, higher productivity and sales, and improved profitability.

Pollution Prevented Through Energy Savings

For each kilowatt-hour (kWh) that you save through the application of energy-efficiency technologies, you are reducing the emissions of carbon dioxide, sulfur dioxide, and nitrogen oxides by the amounts shown in your region (see page 24). Excessive carbon dioxide emission is a primary cause of global climate change; sulfur dioxide is a key constituent of acid rain; and nitrogen oxide is responsible for smog. You will save money and help the environment at the same time, and your customers will appreciate your efforts.

Pollution prevention varies around the country because electric utilities use a variety of fuels and types of power plants to generate your electricity. In the Pacific Northwest, where hydroelectric dams are prevalent, emissions rates are comparatively low. The environmental impact can be just as high, however, because of salmon migration disruption and other issues. In other regions the mix of "clean" coal, "dirty" coal, natural gas, nuclear power, and renewable sources such as wind turbine farms affects emission rates.

An exciting prospect for the deregulated future is the marketing of "green pricing" by electric utilities. Already pilot-tested in parts of California, green pricing allows customers to specify that they want their electricity to be generated from renewable sources (solar or wind) or from particularly clean-burning power plants. In exchange the

ENERGY STAR wants to help you succeed in saving money and preventing pollution, and as long as you are willing, we'll help you make it happen.

ENERGY STAR and Green Lights Program Results Through December 1998

- 19 billion pounds of pollution prevented
- \$800 million in energy savings

Equivalent to

- Taking 1 million cars off the road
- Planting 2 million acres of trees

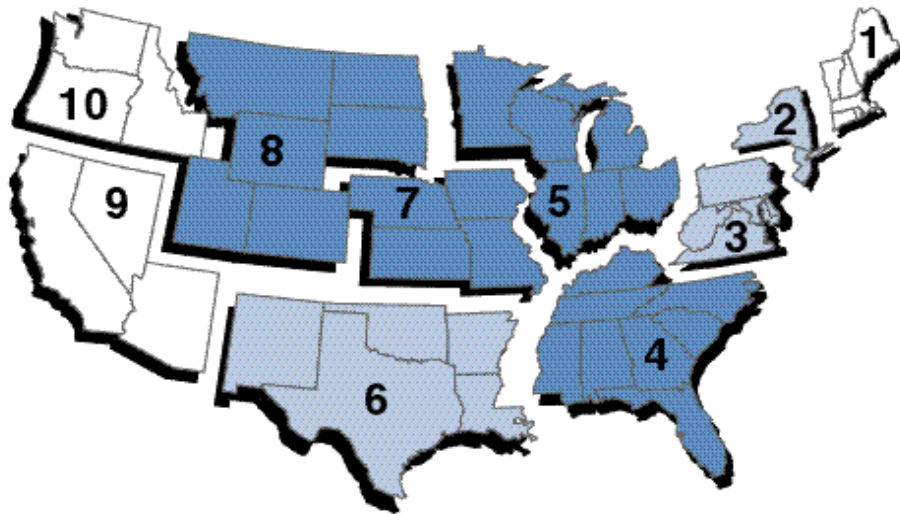

Map of pollution prevented per 1,000 kWh saved.

EPA Pollution Emission Region	Carbon Dioxide pounds/year	Sulfur Dioxide pounds/year	Nitrogen Oxide pounds/year
1	1,100	8.8	3.1
2	1,200	7.5	2.9
3	1,600	7.1	5.5
4	1,500	15.2	5.5
5	1,800	22.9	7.7
6	1,700	4.9	5.5
7	2,000	7.7	8.6
8	2,200	7.3	7.1
9	1,000	2.4	3.3
10	100	1.1	0.7

customer pays a slight premium for this higher grade of power. Look for green power in the future.

Home Offices

The growth of the Internet, telecommuting, and decentralized sales forces has triggered a huge increase in the number of home offices. If you're looking for a new home office, consider the benefits of ENERGY STAR homes. ENERGY STAR homes use 30 percent less energy than required by the national Model Energy Code and have other health and comfort advantages. See page 19 for an example of upgrades made to an existing home office. Call 1-888-STAR YES or visit the Web site at

www.epa.gov/appdstar/homes/ for more information.

Final Thought

Your commitment as an ENERGY STAR partner demonstrates consideration for our shared environment and determination to address the vexing problems of global climate change, pollution, and resource depletion. We would like to thank you for doing your part to pass a healthy planet on to future generations while improving your business' bottom line.

2

Technical Support

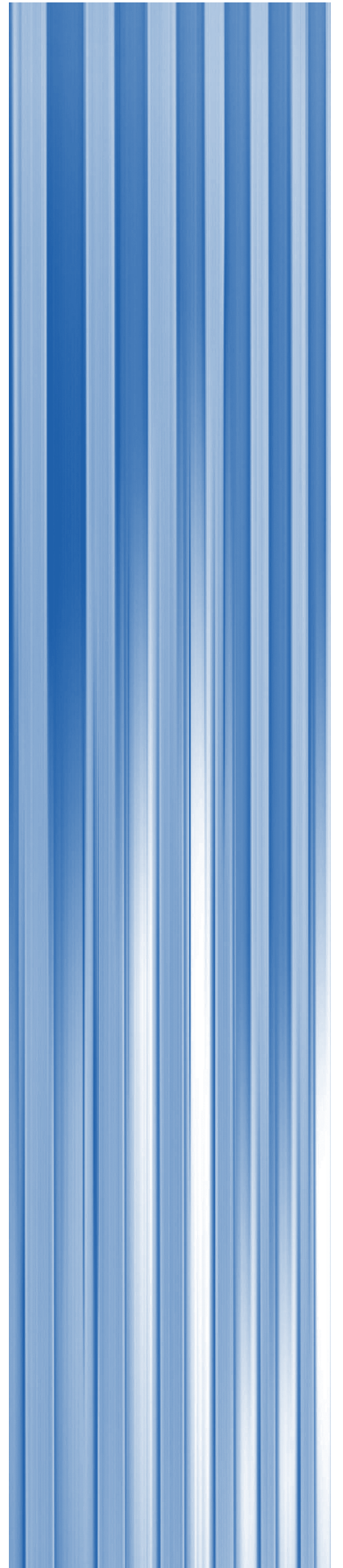

Financial Analysis

Straight to Your Bottom Line

The savings from your energy bills go straight to improving your profits. The National Restaurant Association reports that the average restaurant typically spends approximately two percent of its revenue on energy. Approximately four percent of revenue becomes profit. So if a business owner reduces energy costs by 25 percent (from 2 percent to 1.5 percent), total bottom-line profit increases from 4 percent to 4.5 percent of revenue. This increase in profit is the same as a 12.5 percent increase in sales!

Use the worksheet on this page to calculate the sales increases required to match the value of your savings opportunities.

Indirect Financial Benefits

In addition, the total return on your project includes these financial components that are quite real, if indirect:

Enhanced employee productivity. Due to enhanced comfort and improved lighting conditions, the productivity of your staff may increase.

Operations and maintenance savings. Many energy-efficiency technologies significantly reduce your operations and maintenance requirements, saving money and staff time.

Increased customer comfort. Building upgrades will improve your facility's appearance, make your products look their best, and help your customers enjoy their visit. This can increase sales.

Increased asset value. Efficient businesses have higher market values than wasteful ones. Studies on home sales show an \$11 increase in sales price for every \$1 decrease in annual energy costs. Studies on businesses show a 3-percent increase in stock value after energy upgrades are announced. The market recognizes the business benefits of energy-efficient operation.

Protection from energy inflation. By performing energy-saving upgrades, you are replacing the monthly expense of your energy bills with the fixed cost of the capital improvements. Lower

Savings from your energy bills may directly improve your profits.

What Is Energy Worth to You?

1. You've got a great energy savings idea. How much will it save per year? (A) \$_____
2. Enter your pretax profit as a percentage of sales: (B) _____ percent
3. Divide A by B: (C) _____

Line (C) shows your equivalent annual increase in sales once your savings have paid for the cost of the measure. The table below will help you quickly look up the equivalent sales amount.

Equivalent Annual Increase in Sales

Annual Cost Savings for the Measure	Profit as a Percentage of Sales			
	2%	5%	10%	20%
\$10	\$500	\$200	\$100	\$50
\$100	\$5,000	\$2,000	\$1,000	\$500
\$1,000	\$50,000	\$20,000	\$10,000	\$5,000
\$10,000	\$500,000	\$200,000	\$100,000	\$50,000
\$100,000	\$5,000,000	\$2,000,000	\$1,000,000	\$500,000

Spreading the Word

The Uptown Shelby Association in Shelby, North Carolina (pop. 14,669) is reaping all of the benefits from their involvement with Rebuild America and the ENERGY STAR small business program. Its Rebuild America partnership, Rebuild Shelby, promotes the small business program to its downtown, small commercial, business owners. Ted Alexander, the executive director of the Uptown Shelby Association states, “As a partner in Rebuild America, we wanted to promote the ENERGY STAR small business service as an important opportunity that local businesses should take advantage of.” Alexander took the initiative in marketing by requesting hundreds of small business brochures, and along with a letter describing the services offered, sent them to local business and property owners to educate them in the positives of energy efficiency.

Simple Payback: A Typical Business Ranking

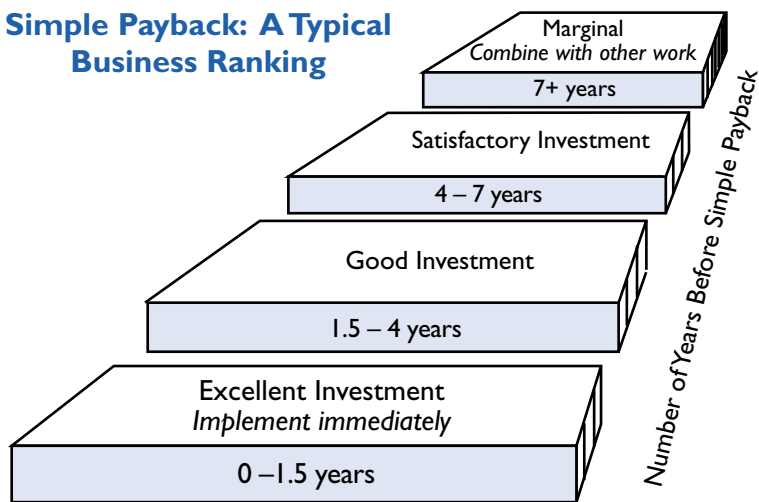

energy use will always result in lower cost—more so if energy prices rise.

Marketing benefits. Your participation in the ENERGY STAR for small business program communicates your commitment to environmental stewardship. This message differentiates your business from those of your competitors.

Your exact mix of indirect benefits will vary by business type and upgrades performed. For many projects, these indirect benefits will be worth several times the money you save in energy alone.

But Is It Really Worth the Time and Money?

Once you are convinced that energy-efficiency investments make financial sense in general, you still have to evaluate individual upgrades to decide which to pursue. The two most common evaluation tools are simple payback and internal rate of return (IRR).

Simple payback. Simple payback is the number of years it takes to recover the cost of the energy upgrade from the energy savings. A simple payback under four years indicates a worthwhile project. Measures with simple payback times of less than 1.5 years are excellent opportunities and should be implemented immediately.

Example of a Simple Payback Calculation. Your utility gives you a free energy assessment and tells you that if you replace 20 100-watt incandescent bulbs used 24 hours a day in your stairways with 30-watt compact fluorescent bulbs (30 watts each) you’ll save \$980 per year. The upgrade will cost you \$400.

Your simple payback is $\$400 \div \$980 = 0.4$ years, or just under 5 months.

Many businesses use simple payback to make financial decisions. The only significant shortcoming of the simple payback concept is that it doesn’t take into account the expected life of the upgrade. For example, if the compact fluorescent lamps described above lasted only as long as incandescent lamps, they would burn out in less than three months. Fortunately, compact fluorescent lamps last 9 to 13 times longer, so you might want your analysis to take that into account.

Internal Rate of Return. Expressing an upgrade in terms of IRR will help you compare the financial results of

Compare Your Energy-Efficiency Investments to the Interest Rates You Can Get at a Bank This table will tell you the Internal Rate of Return if you have already calculated the simple payback.									
Simple Payback	8 years							0%	4%
	6 years						0%	7%	11%
	5 years					0%	5%	12%	15%
	4 years				0%	8%	13%	19%	21%
	3 years			0%	13%	20%	24%	29%	31%
	2.5 years			10%	22%	29%	33%	37%	38%
	2 years		0%	23%	35%	41%	45%	48%	49%
	1.5 years		22%	45%	55%	60%	63%	65%	66%
	1 year	0%	62%	84%	93%	97%	98%	100%	100%
	0.5 years	100%	173%	192%	197%	199%	200%	200%	200%
	0 years	1 year	2 years	3 years	4 years	5 years	6 years	8 years	10 years
Lifetime of new equipment or length of your planning horizon, whichever is shorter									

an upgrade against other investments. (See the glossary for the definition of IRR.) To calculate IRR you'll want to use a computer spreadsheet program or a financial calculator; you can use the table on this page as a general reference.

You can compare the IRR you calculate with the interest rates available at banks or through other investments. A good rule of thumb is that projects with IRRs above 20 percent are

excellent investments and should be implemented.

Example of IRR. Converting your warehouse heating system from natural gas unit heaters to gas-fired radiant heaters will cost \$6,000 and save \$1,500 a year, which is a simple payback of four years. You can calculate the IRR for this investment as 21 percent (using a 10-year planning horizon), which makes it a very good financial option. Compare this with

Success Stories

The manager of a small restaurant in St. Louis installed new lights and roof insulation. The total project cost \$600 and saved approximately the same amount in a year. The business' overall profit margin was five percent profit against revenue.

Because energy cost savings went straight to the bottom line, the measures contributed \$600 to the business' pretax profit after the first year ended.

The savings were worth the equivalent of \$12,000 in additional sales. For the manager, cost reductions of \$600 were easier to achieve than increasing sales by \$12,000.

Simple payback is the number of years it takes to recover the cost of the energy upgrade from the energy savings.

Upgrades should generally be implemented if the IRR is above 20 percent.

bank interest rates or other investments you might make (even including other ways to improve your business such as marketing or staff training) to decide whether to do this upgrade.

Where Can I Learn More?

Call the toll-free ENERGY STAR hotline at 1-888-STAR YES and ask for the brochures listed below:

Introducing Your Company's Newest Profit Center, EPA 430-R-97-004. This is an introduction to the concept that energy upgrades are financial investments just like other business uses of capital.

Business Analysis for Energy-Efficiency Investments, EPA 430-B-97-002. This brochure describes in more detail the business-analysis approach you can use to decide if a particular upgrade or set of upgrades makes sense to invest.

Financing Your Energy-Efficiency Upgrade, EPA 430-B-97-003. This brochure describes the many financial and accounting aspects of upgrade projects in great detail. Use this information to finance your projects with the best impact on your balance sheet, cash flow, taxes, and ultimate return.

Visit special Web pages for restaurants, grocery stores, lodging, manufacturers, home-based, and other business types at www.epa.gov/smallbiz, or ask for "small business tech support" at 1-888-STAR YES.

Success Stories

Kiddie U, a 15,400 sq. ft. daycare and learning facility in Orlando, Florida, has the lowest energy costs per sq.ft. of any comparable facility in the state, according to the Energy Conservation Assistance Program at the University of Central Florida Small Business Development Center, which provided technical support for Kiddie U's upgrade. At \$1,500 per month for combined water and energy costs, President Joseph Manella's new facility costs about 40 percent less to operate than his prior building, due to high efficiency air-conditioning, programmable thermostats, T8 fluorescent lamps with electronic ballasts, CFLs, occupancy sensors, and improved insulation.

Prioritizing Your Projects

Use the ENERGY STAR five-stage concept to help organize a strategy for putting potential upgrades on a timeline. Each stage of the program builds upon the accomplishments of the previous stages to maximize potential energy savings, minimize investment requirements, and improve comfort and profitability for your business.

Rebuild America promotes a whole-building, systems approach in order to significantly increase energy savings for each building and to accommodate the wide variety of project types and partnerships in the program. A comprehensive analysis of the whole building is recommended to take full advantage of equipment savings due to reduced heating and cooling loads and to develop a total project plan. There also is a big savings in time and effort, and possibly reduced bids, by contracting for the total job. A phased approach to project implementation may be necessary for some projects, but building owners often go with the whole package so they can finish construction and enjoy full benefits.

Stage One: Lighting

Many retailers and offices spend half of their electric bills on lighting, so it makes sense to address lighting first. Efficient lighting pays for itself quickly. Lighting upgrades such as installation of compact fluorescent lamps and light-emitting diode (LED) exit signs are relatively simple to implement and can reliably deliver the expected cost savings. Upgrade your lighting before changing your heating or cooling systems because increasing your lighting efficiency lowers your air-

conditioning requirements. In the winter, heating your building with your lights is expensive because new lights operate much cooler than old lights. Use your heating system instead. Five years of ENERGY STAR experience show that successful lighting upgrades provide Partners with dramatic savings and positive reinforcement for pursuing further projects. Lighting upgrades often improve lighting quality, which can boost worker productivity and enhance the appearance of your merchandise.

Stage Two: Building Tune-Up

Bring your building to its peak design performance by addressing operations, maintenance, and small repairs. You can do many tune-up activities yourself, such as cleaning equipment and replacing filters. Other measures, such as adjusting your furnace or repairing malfunctioning controls, will require the services of contractors. Stage Two upgrades improve occupant comfort and indoor air quality, and the upgrades are no-cost or low-cost strategies that lay the foundation for further savings later.

Stage Three: Load Reduction

Load reduction strategies reduce the amount of heating, cooling, or electricity use through low-cost measures that are easy to implement. Reducing the amount of heated or cooled air that escapes from your building through cracks in windows or ducts will reduce your heating and cooling costs.

Each upgrade stage builds upon the previous stages to maximize -potential energy savings, minimize investment requirements, and improve comfort and profitability.

Window films, shades, and awnings will reduce heat gain in the summer. Or you can take advantage of landscaping measures such as adding trees and vines to block direct sunlight.

You can take simple steps to ensure that lights and office equipment are not left on by accident. And select ENERGY STAR-labeled new equipment to guarantee the best future savings.

Stage Four: Heating and Cooling Distribution System

In this stage, you should evaluate the efficiency of the fans and pumps associated with the heating, ventilating, and air-conditioning (HVAC) systems in your building. Upgrades to your distribution system will save energy while improving occupant comfort.

Stage Five: Heating and Cooling Plant

By implementing Stages One through Four, you will reduce the overall heating and cooling requirements in your facility and will be able to afford smaller and more efficient heating and cooling units. Because replacing heating or cooling equipment requires the largest commitment of capital, we recommend that you implement these replacements last. Stage Five is when all your previous hard work and commitment will pay off.

The five-stage concept is illustrated in the chart on this page.

Where Can I Learn More?

If you would like more information on the technical aspects of the ENERGY STAR five-stage approach to building improvements, call 1-888-STAR YES and ask for the free, more advanced *ENERGY STAR Buildings Manual*.

Stage Five: Heating and Cooling Plant

- Reduce size after Stages 1 – 4 upgrades
- Offers maintenance advantages
- High savings potential, but large investment

Stage One: Lighting

- Fast payback
- Improves comfort
- Reduces cooling costs

Stage Two: Building Tune-Up

- Low-cost measures
- Operations and maintenance
- Reduces heating and cooling costs

Stage Three: Load Reduction

- ENERGY STAR-labeled office equipment
- Windows, window films, awnings
- Cracks sealed
- Water heater insulation

Stage Four: Heating and Cooling Distribution System

- Resize the system to meet new loads
- Install advanced controls

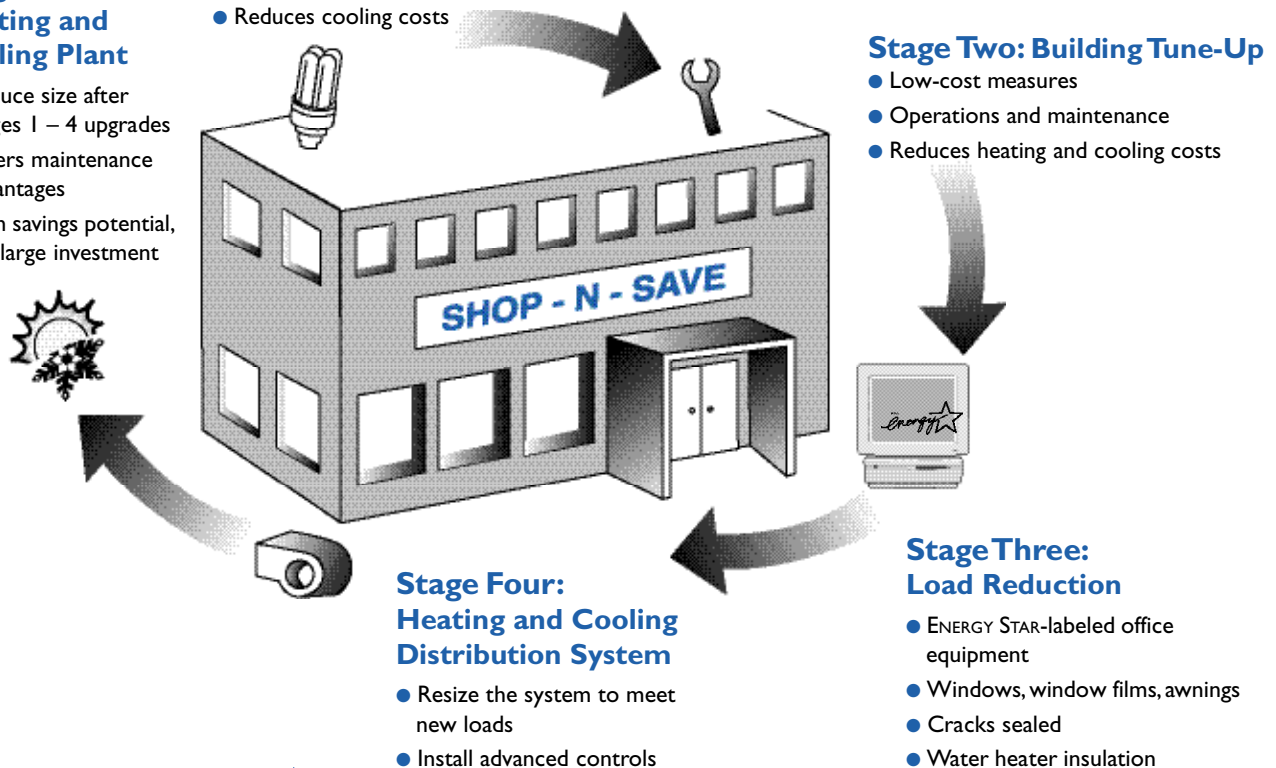

Lighting Part I: Concepts

Approximately 75 percent of all small business energy upgrades are related to lighting. Because lighting upgrades are so popular, we have included this special section on lighting concepts. If you have time to read it, you can be an informed shopper when it comes time to listen to contractor upgrade proposals or even to find your own lighting improvement opportunities. If you don't have the time, aren't interested in the background science, or just want to focus on action, go straight to the next section, *Lighting Part II: Upgrades*. We introduce specific suggestions on how to improve your lighting by upgrading your fixtures.

Whether displaying your merchandise, illuminating your factory, or providing security for your parking lot, lighting is one utility that you as a small business owner cannot do without. The amount and quality of the light can significantly affect the performance of your employees. At the same time, light also forms a significant part of your electric bill.

Fortunately, modern technology makes it possible for many businesses to improve lighting quality while reducing costs. This section first reviews how to determine the "right" amount of light for your business, discusses lighting quality issues such as color and glare, and then introduces the different types of lighting technologies in use.

Light Levels

When everyone worked with pencils, paper, and typewriters, architects made sure that working environments had an abundance of light everywhere. Now that so many office environments

require the use of computers, ideal light levels and configurations are different and often lower than in the past. This means you may have the opportunity to reduce your lighting costs and improve your working environment at the same time. Since removing lamps often requires nothing more than getting on a ladder and pulling out the lamps, the cost can be negligible and you can start saving money immediately.

Although employee preferences play a large role in optimizing light levels, the Illuminating Engineering Society provides recommended light levels for different activities as shown in the graph on this page.

Compare your light levels to recommended levels. In order to compare your lighting to recommended levels, you need to know your own existing light levels. Call your lighting contractor and ask them to take the measurements for you.

Proper light levels and light quality can measurably increase sales and productivity.

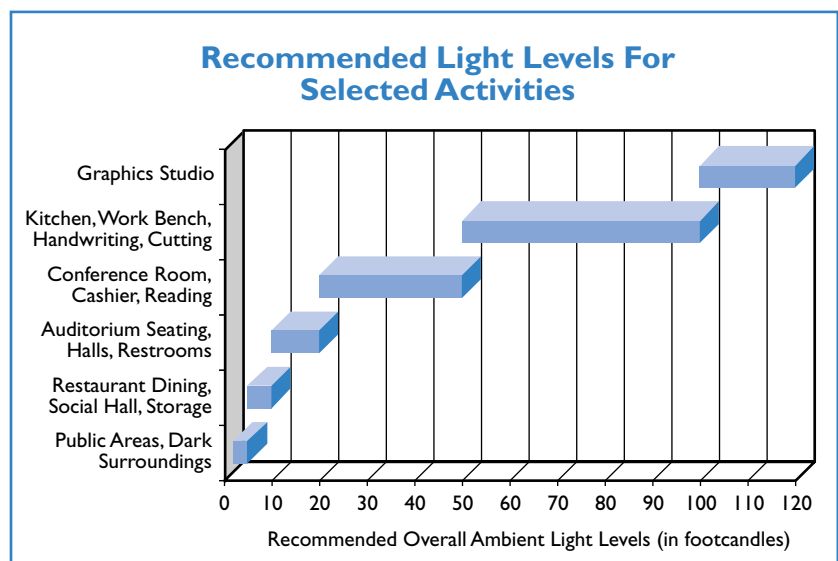

Task lighting focuses extra light just where you need it and can reduce glare and eye strain.

Deep-cell parabolic fixtures are great for offices with computers because they reduce reflections in the monitors.

Alternatively, you may want to consider buying your own light meter. They cost about \$125 and are available from lighting supply catalogs. If you buy a meter, be sure to have a lighting expert train you before you use it. Windows, reflections, and shadows will distort your readings if you're not careful.

Just try it. You don't have to bother with all those technical criteria. Remove a couple of lamps for a couple of days, and if you like the new arrangement, stick with it.

Consider task lighting. Just because you want bright light at the cash register doesn't mean you need the whole room lit up to that level. See if you can reduce light levels in some areas and focus light only where you need it. This is called "task-ambient lighting." This type of lighting design provides a blanket of lower level "ambient" light for orientation around large objects together with small fixtures shining on the "task." The current IES recommendations for computer use, for example, are 25 footcandles ambient, with a task or desk light providing 75 footcandles at the work surface.

Experiment with daylighting. Turn off lights near windows during daytime hours; you can do this manually, with a time clock or with special "daylighting" sensors made just for this purpose.

Light Quality

Isn't it frustrating to stare at your computer screen and constantly find yourself looking at the reflection of a ceiling fixture? Have you seen a fellow employee tape cardboard around the monitor? Does the light in the restroom make your face look pasty and less attractive than you know you looked at home this morning? It's not that

work is bad for your looks. All light is not the same. It turns out that these and other problems are lighting flaws that can often be overcome when you install more efficient lighting. Let's consider solutions to the problems one by one.

Solution 1: Task-ambient lighting.

Your problem may be fixture location. Moving the monitor is one solution, certainly, but a solution that more and more interior designers recommend is a combination of background ambient and task lighting. Designers generally agree that spot lighting gives a pleasant ambiance, but it can cost more to install because it requires more fixtures. Because the overall amount of light produced is lower with a mix of background and spot lighting, the arrangement uses less electricity. The extra fixture investment can pay for itself quickly in savings on your electric bills. Happier employees can be worth even more.

Solution 2: Upgrade fixtures.

Many older fluorescent fixtures use a prismatic plastic lens (see the glossary in Section 3) to scatter light around the room. This was great before the computer age because it helped ensure that all areas were evenly lit, but lenses can create bright spots in your field of view. Now that computers are used everywhere, the preferred solution is often to use fixtures with parabolic louvers that direct light where you need it while lowering glare. If you're considering an upgrade in a room with computers, definitely ask your designer or contractor about switching to fixtures with louvers.

Solution 3: Improve color.

All lamps distort color compared to true sunlight, but some lamps are better than others at simulating sunlight. This property of lighting is called color rendition. Lamps that render close to true color have a color-rendering index between

85 and 100. A CRI of 50 is very poor. If you upgrade to T-8 lamps from just about any type of T-12 lamps, your color will improve and your product will look better. And better looking merchandise is better selling merchandise.

Different Kinds of Lights

Different types of lighting are available for different applications, with a broad range of lighting efficiencies and varying degrees to which they distort color. The efficiency of lighting (more technically called efficacy) is measured by the light output per unit of energy use. Common incandescent lamps have poor efficiencies, while fluorescent lamps have much higher efficiencies. See box on this page for illustrations of the major lamp types.



Incandescent. Modern incandescent lamps derive from Thomas Edison's work before the turn of the 20th century. They are inefficient and usually have short lives but produce a pleasant color rendering similar to that of natural sunlight.



Halogen. In the past five years, halogens have surged in popularity. Halogen lamps are about twice as efficient as regular incandescent lamps and have longer lives. Halogen spotlights focus light and add a lot of pleasing "sparkle." However, they are relatively expensive to buy, and they cost more to operate than all types of lamps except incandescents.

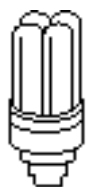

Compact fluorescent. Compact fluorescent lamps are miniature versions of standard fluorescent lamps and are usually coated to make their color more similar to that of incandescent lamps. Compact

Types of Lighting Lighting Technology

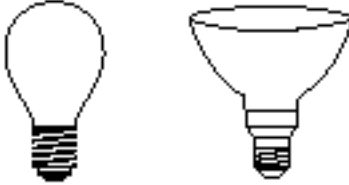
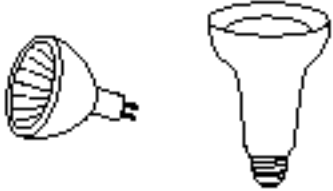
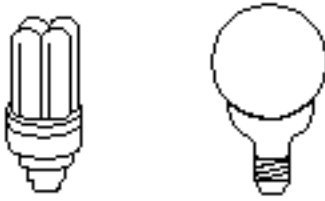
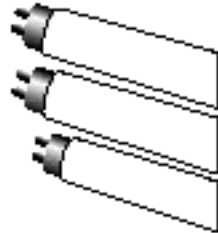
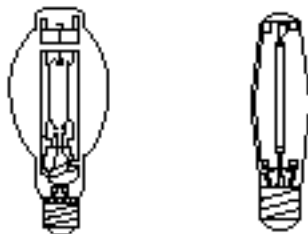
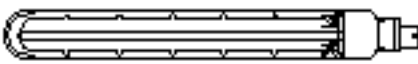
	Incandescent
	Halogen
	Compact Fluorescent
	Tubular Fluorescent
	High-Intensity Discharge (HID)
	Low-Pressure Sodium

Less than five percent of the electricity consumed by an incandescent lamp is actually turned into useful light.

fluorescents are 4 times as efficient as incandescents and last 10 times as long in many cases, so they too are growing in popularity in the business world. They are relatively expensive to buy.

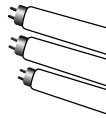

Tubular fluorescent. The ubiquitous fluorescent lamps have a wide range of efficiency and in general are about four times as efficient as incandescent lamps. They are cheap to buy, last as long as 20,000 hours, and are the staple for office lighting throughout the country.

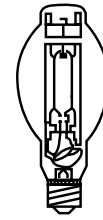

High-intensity discharge (HID). This category of lamp includes mercury vapor, metal halide, and high-pressure sodium. HID lamps have traditionally been used mostly in warehouses and street lighting, but new research and development have created a market for lower power lamps for commercial environments. HID lamps offer good color, long life, inexpensive high ceiling and security lighting, and new retail options.

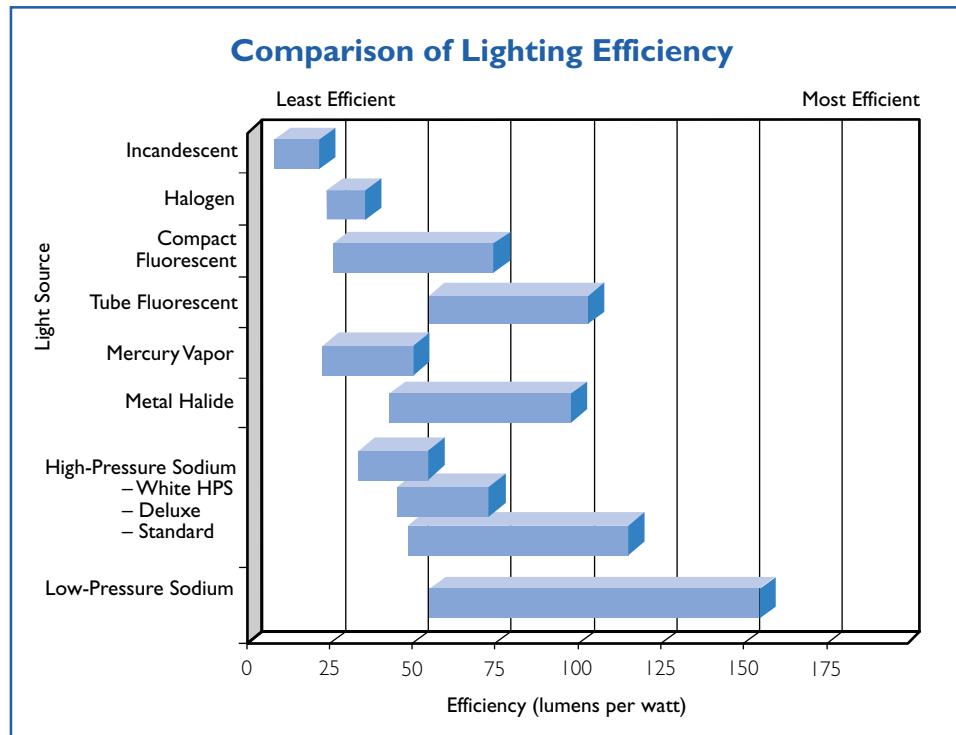

Success Stories

Business Saves With the Right Light Levels

A growing software development firm in Portland, OR, signed a 10-year lease to occupy a 30-year-old, 50,000-sq.ft. office building. The business planned to renovate much of the space before moving in. Renovation plans for each 10-ft. by 12-ft. office in the building included replacing a pair of old, 4-lamp, 4-ft. fluorescent fixtures in each office with a pair of new 4-lamp fixtures that had high-efficiency lamps and electronic ballasts.

Fortunately, the business asked its design consultant to check the light levels before signing off on the remodel drawings. The consultant checked and found that the existing light levels were about 75 foot-candles (units of measure), when 50 footcandles would have been plenty. So at no cost to the tenant, the designer changed the construction specifications to 3-lamp fixtures. There were 200 offices affected by this renovation, meaning that the firm saved more than \$15,000 in 10 years by asking one simple question. That's a good deal.

Better Lighting Increases Sales and Productivity

New energy-efficient lighting can do more than just reduce your utility bills. It can also add value by:

- *Improving employee comfort and performance.* Energy-efficient lighting generates less localized heat than standard lighting, provides more pleasant color rendition, and helps prevent people from getting headaches by reducing the amount of flicker from the lights. Your employees will work better when their work environment is comfortable.
- *Improving sales.* Better color rendition means that your merchandise will look more appealing. Much like Muzak® in grocery stores, improved lighting will make customers feel more comfortable, and they will choose to stay longer in your store. This leads to more sales.
- *Improving your business' image as an environmentally responsible partner in your community.* Your customers will appreciate your efforts to lower pollution and protect the Earth for future generations.

Lighting Part II: Upgrades

What's your share of \$17 billion? That's the amount EPA estimates commercial building owners and tenants could profitably save each year from lighting upgrades.

In this section we will help you identify lighting fixtures and controls in your own facility that can be replaced and add profits to your bottom line while keeping your investments a three-year simple payback or less. Many ideas pay for themselves in less than one year. Let's get started!

If you don't have time to read the whole section, just take a quick look at the next page. It's our *Thrifty Manager's High-Speed Do-It-Yourself Lighting Assessment*. Take a look at the action list, and call your lighting or electrical contractor if you have any of the fixtures noted. It's that easy.

The rest of this section expands on the ideas in the High-Speed Lighting Assessment and explores more comprehensive upgrades as well.

Remove Incandescent Lamps



Replace these lamps with *anything* else. Of the electricity consumed by an incandescent lamp, less than five percent is actually turned into useful light. Although incandescent lamps are appropriate for certain low-use areas such as closets, in most commercial applications incandescent lamps should be replaced.

Incandescent Lamp Replacement Options

Halogen	To highlight your product. Example of application: retail
Compact Fluorescent	To keep the same screw-in fixture. Example of application: hotel hallway
Tube Fluorescent	For general lighting.
Metal Halide	For white light in high-ceiling areas. Example of application: warehouse
High-Pressure Sodium	For use outside or where color doesn't matter. Example of application: outside security
LED	For exit signs.

Note: "Energy Saver" incandescent lamps aren't much more efficient than regular incandescent lamps. They save you money just by delivering less light. Usually this is not the best solution.



Replace incandescent lamps with halogen lamps.

Halogen lamps are a type of incandescent lamp that is about twice as efficient as regular incandescent lamps. They last two to four times longer than most incandescent lamps, and they have become increasingly popular in spot lighting and other decorative applications. Halogen lamps are particularly popular in jewelry and upscale retail stores because they make gold and gems really sparkle.

The Thrifty Manager’s High-Speed Do-It-Yourself Lighting Assessment

Do you have any of the following?

EXISTING LAMPS	USED AT LEAST
Incandescent lamps	6 hrs./day
Incandescent exit signs	24 hrs./day
Four or more fluorescent or incandescent fixtures on a single circuit	4 hrs./day more than needed
Incandescent or mercury vapor security lighting	10 hrs./day
Fluorescent lamps and ballasts more than eight years old	10 hrs./day

If you do, here are some of your savings opportunities.

OLD	NEW	SAVE (\$/yr/lamp)	PAYBACK IN LESS THAN
Incandescent	Compact fluorescent	\$12 energy + \$3 O&M*	2 yrs.
Incandescent exit signs	LED exit signs	\$22 energy + \$11 O&M*	3 yrs.
Four or more fluorescent or incandescent fixtures on a single circuit	Occupancy sensor	\$4 to \$16 + \$4 O&M*	3 yrs.
Incandescent or mercury vapor security lighting	Metal halide (white) or sodium (light yellow)	\$40	4 yrs.
Fluorescent lamps and ballasts more than eight years old	T-8 lamp with electronic ballasts	\$5	5 yrs.

* Operations and Maintenance

As an upgrade, the combination of better color, higher efficiency, and better cone reflectors means that many users can replace 150-watt floodlights with 35- or 60-watt halogen lamps and still get brighter, more focused light that has better color rendition. The most popular halogen lamps cost about \$7 (compared with \$1 for incandescent lamps), but they last four times as long as incandescent lamps and save about \$25 in energy costs over their lifetime. They are a good deal even before you consider labor costs and the fact that they help move merchandise. The high operating temperatures of halogen bulbs can be a fire and personal safety hazard in some applications, so ask for advice when you first buy and install the lamps.

Halogen lamp retrofits typically pay for themselves in less than three years in energy savings alone if the fixtures are used at least two hours a day for screw-in retrofits or if used at least eight hours a day for fixture replacements.

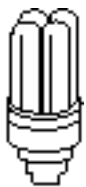

Replace incandescent lamps with compact fluorescent lamps.

Compact fluorescent lamps are fluorescent lamps that have been specifically made in a compact form to replace incandescent lamps in traditional screw-in fixtures. Compact fluorescent technology has improved recently, and the lamps currently available in the marketplace are brighter and have very good color rendition properties. For example, most modern hotels have installed compact fluorescent lamps for corridor lighting. The fixture pictured on this page contains a compact fluorescent lamp and costs less than \$40. Compact fluorescent fixtures with reflectors provide an excellent substitute for floodlamps.

The table below shows the equivalency of compact fluorescent lamps to incandescent lamps. You can replace these yourself—most major hardware stores stock compact fluorescent lamps that screw right in place of incandescent lamps and cost as little as \$5 on the Internet. Utility rebates can reduce your cost even further.

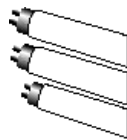

Replace incandescent lamps with tubular fluorescent lamps.

Fluorescent lamps are the common tube lamps found in almost every small business. They are usually about three to four times more efficient than incandescent lamps and can last 8 to 20 times longer. With newer fluorescent lamps, you can also specify color correction to avoid the pasty image traditionally associated with fluorescent lamps.

Tubular fluorescent lamps have much lower maintenance costs than incandescent or compact fluorescent lamps.



Would you believe this attractive fixture is made specifically for compact fluorescent lamps and costs less than \$40?

If You Have Incandescent Lamps	Replace Them With These Compact Fluorescent Lamps
25 watts	5 watts
40 watts	7 watts
60 watts	13 watts
75 watts	22 watts
100 watts	27 watts

Lamp Type	Energy Costs	First Cost	Life	Color	Maintenance Costs
Incandescent	Much Higher	Lower	Shorter	Good	Higher
Fluorescent	Much Lower	Higher	Longer	Better to Worse	Lower

Replace your incandescent lamps with just about any variety of fluorescent lamp and your lighting, energy, operating, and maintenance costs may decrease by about 75 percent.

EXIT Replace incandescent exit signs with light-emitting diode (LED)

exit signs. LED exit signs use light-emitting diodes that provide exit lighting and are commonly seen in electronic devices such as clock radios.

You can buy an upgrade kit to convert existing exit signs for \$15 to \$75 and do it yourself, or you can purchase

new fixtures and install them for less than \$100. Because the upgrade kits don't require any wiring, they are easier to install yourself than new signs if there is room inside the panel to install them. LED exit signs use about five percent of the energy used by incandescent exit signs and 20 percent of the energy used by compact fluorescent exit signs. LED exit signs also last 10 to 20 times longer.

The most efficient LED exit signs on the market today are part of the EPA ENERGY STAR LED program. ENERGY STAR-labeled exit signs save on maintenance costs because of their long life. An ENERGY STAR-labeled LED exit sign can last 25 years without a lamp replacement, compared to less than one year for an incandescent. Look for the ENERGY STAR label when purchasing your new exit sign.

Given their installation costs, their lower maintenance costs, and low energy costs, they generally pay for themselves in one to three years. For more information on ENERGY STAR manufacturers you can visit our Web site at www.energystar.gov

See the bar chart on this page for annual operating costs for exit signs.

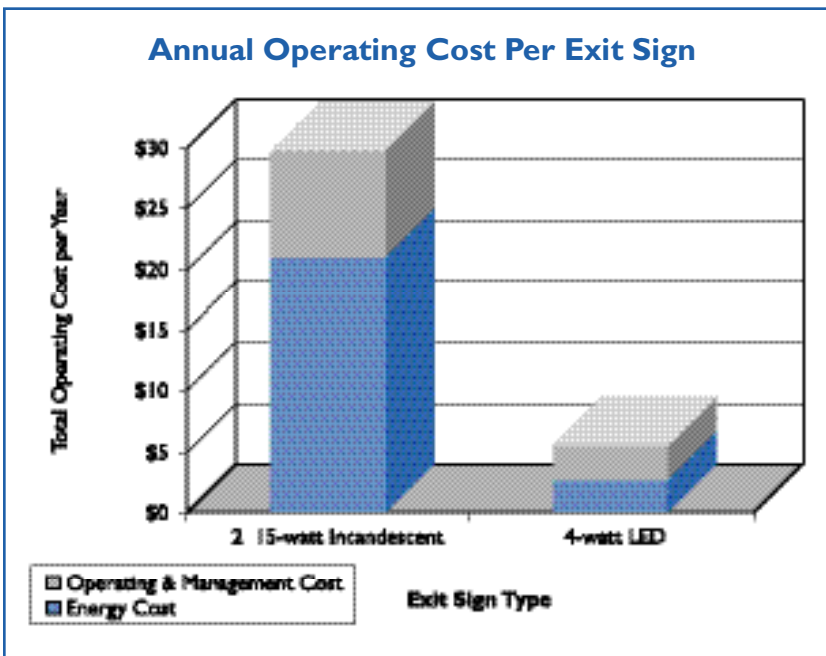

Upgrade Fluorescent Lamps

Even within the generally efficient category of fluorescent lighting, you can reduce your energy use by more than 66 percent by changing from the worst to the best type of fluorescent tubes. Fluorescent lamps were introduced at the World's Fair in New York City and San Francisco in 1939. Surprisingly, their designs changed little over the years until recent breakthroughs that have significantly improved their efficiency and the quality of the light they produce.

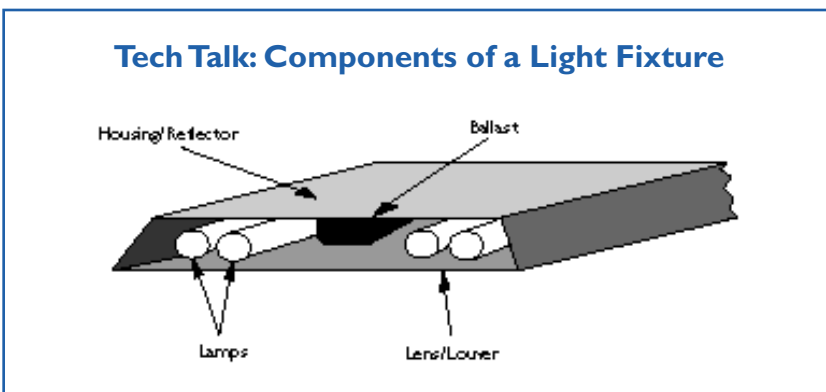

T-8 lamps and electronic ballasts.

T-8 lamps use their smaller diameters, phosphors, and coating to improve efficiency by about 10 percent compared with standard T-12 lamps. Electronic ballasts use about 30 percent less energy than old magnetic ballasts. Ballasts are devices that provide the proper voltage and current to fluorescent lamps, which don't regulate themselves like incandescent lamps. T-8 conversions cost \$50 to \$100 per fixture, so you might wonder

if it is worth the trouble. The answer depends on your local electricity costs and how often you use the lights. Generally if you use the lamps 60 hours per week or more the answer is "yes" or at least "yes, it's worth finding out more information." All you need to do is ask your local lighting contractor or electric utility company to perform a detailed analysis for you. This can usually be done free of charge.

Other ideas. T-8 lamps and electronic ballasts aren't your only solution. Modest gains are achieved from 34-watt "energy saver" lamps. De-lamping and/or reflectors can help also, as discussed later in this section. Some designers are switching from fluorescent tubes to lower power metal halide fixtures for a more industrial look. Consider the example scenario shown at the bottom of this page. There are four different retrofit options. None is the single "right" answer. They are all

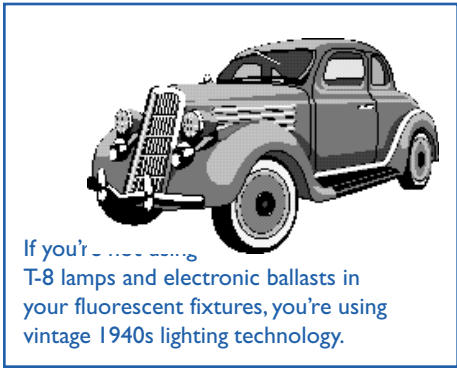

Explore Your Options

A business has 20 4-lamp, 4-ft. fluorescent fixtures in an office area. They are on about 50 hours a week. The primary tasks of most occupants require computer use. Recommended light level is between 50 and 75 footcandles.

Current Light Level	95 footcandles
Current Energy Use	9,984 kWh/year
Current Annual Energy Costs (at \$0.08/kWh)	\$799

Upgrade options	Energy savings kWh/year	Cost \$	Annual savings \$	Simple payback years	Light level	Light quality
Option 1: Install 34-watt "energy saver" lamps. Light level is lowered to about 85 footcandles.	1,664	\$360	\$133	2.7	Improved	Slightly better
Option 2: Install four T-8 lamps and an electronic ballast in each fixture. Light level remains the same.	3,744	\$1,280	\$300	4.3	Still too high	Much better
Option 3: Install two T-8 lamps in each fixture, with a specular reflector. Fixtures are "tandem-wired" so two fixtures share a single ballast. Light level becomes 55 footcandles.	6,916	\$1,340	\$553	2.4	Ideal	Much better
Option 4: Install new deep-cell parabolic fixtures with T-8 lamps and electronic ballasts. Fixtures are "tandem-wired" and light level becomes 55 footcandles.	6,916	\$2,600	\$553	4.7	Ideal	Ideal

If you replace your outside security incandescent lamps with sodium lamps, your exterior lighting costs may decrease by 80 to 90 percent.

viable, cost-savings, quality-enhancing ideas. Choosing between them is a business and design decision.

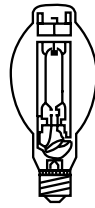

Install High-Intensity Lamps

If you work in a warehouse with high ceilings and don't have fluorescent lamps, you probably use high-intensity discharge (HID) lamps. Mercury vapor lamps use older technology and are less efficient than other HID lamps, although they do provide a white light.

Upgrade from mercury vapor. At a bare minimum, you should replace mercury vapor lamps with more efficient metal halide lamps as the old lamps burn out. Even if you need to replace the ballast or the whole fixture, it turns out to be economical for almost everyone and no one can even tell you're doing it. Metal halide lamps render colors as well as mercury vapor lamps. They come in a variety of power outputs from 50 to 2,000 watts and have long life. They also come with a clear or coated bulb. The coated bulb has the best color rendition property and can be used for display lighting.

Use metal halide for retail. You've probably seen metal halide lights

without even realizing it. Most of the new "big box retail" stores are illuminated using metal halides. They are the bright white lights typically hung from the ceiling girders at 20 to 30 feet. If you have high bay retail, switch from fluorescent to metal halide for a brighter look without increasing your energy costs. Typical payback: five years, less if it increases sales.

Also, manufacturers have recently started selling small metal halide spotlights. The bright white light combined with the narrow beam and sparkle can make merchandise really stand out—the benefits of halogen with lower energy costs!

Use metal halide or high-pressure sodium in warehouses.

Choose high-pressure sodium where light quality is not critical and rock-bottom energy use is the goal. Typical payback based on 12-hour-per-day warehouse use is about three years.

Use metal halide instead in high-profile or color-sensitive areas or areas where people need to perform detailed work.

Install high-pressure sodium lamps outside.

High-pressure sodium lamps are popular for warehouse, outdoor, street, and security lighting. They come in a variety of power outputs from 35 to

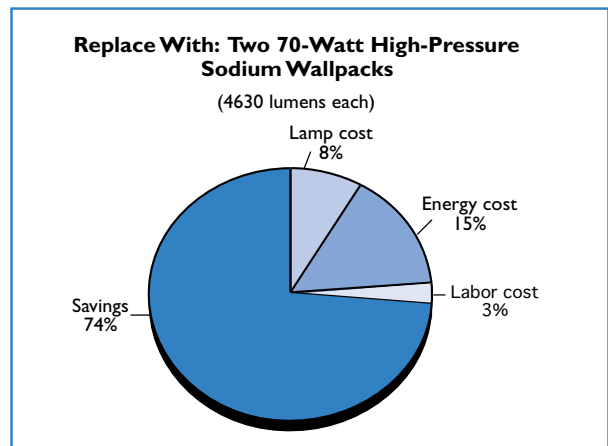
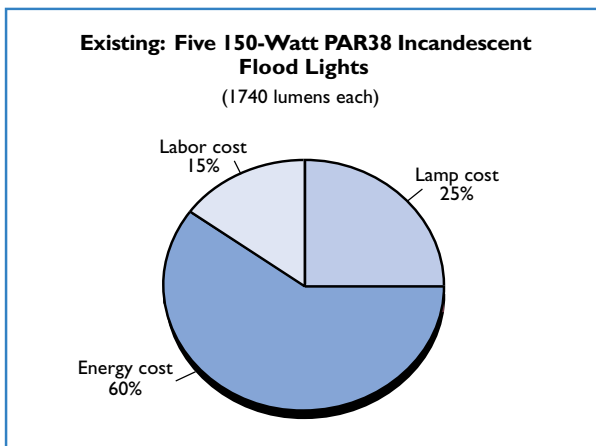

1,000 watts and have about a 20,000-hour life. Sodium lamps are the most efficient lamps you can buy. Most of them have a light yellow tint, but some of the newer lamps have an attractive white color rendition and can even be used for display purposes. These new lamps tend to fade from white after a certain number of hours of use, so be sure to discuss the issue with your contractor prior to installation in customer service areas.

Carefully consider low-pressure sodium lamps. They are efficient but *very* yellow and usually not recommended, except for loading docks and some security uses. Replace your outside security incandescent lamps with sodium lamps and your costs may decrease by between 80 and 90 percent. The typical payback time is less than two years.

Remove Lamps

What could be a better deal than getting savings with no up-front cost? In many offices 2 lamps in a 4-lamp fluorescent fixture may be removed while still meeting recommended lighting levels. People working on computers will probably prefer the lower level because it increases the contrast on their monitors. You can experiment to see if removing lamps makes sense in your facility. Corridors are also good places to start because these areas often are overlit. Cost: \$0. Simple payback time: 0.0 years.

Lowering the number of lamps can also be an excellent measure when combined with installation of reflectors. Reflectors are not for everyone. We've found reflectors are best applied to areas that start with about 50 percent too much light and 4-lamp fluorescent fixtures. If that sounds like your site, remove half of the lamps and add reflectors to meet your target amount of light. Ask a lighting professional if they would be applicable in your facility.

Controls To Turn Lights Off

One easy way to save money and help your lights last longer is to turn them off when they are not needed. Occupancy sensors detect people in a room using ultrasonic or infrared sensors. These sensors cost between \$25 and \$80 and are an excellent choice for bathrooms or conference rooms that are likely to be unoccupied for large portions of the day. Photocells are designed to turn exterior lights on automatically when it gets dark. Motion sensors are suited to exterior security lighting, loading dock areas, and doorways. These sensors turn lights on automatically when a person is detected.

Automatic dimming systems that adjust lamp output based on measured sunlight also are starting to find application.

Energy-Savings Potential With Occupancy Sensors

Application	Energy Savings
Offices (private)	25–50%
Offices (open spaces)	20–25%
Rest rooms	30–75%
Corridors	30–40%
Storage areas	45–65%
Meeting rooms	45–65%
Conference rooms	45–65%
Warehouses	50–75%

Note: Figures listed represent maximum energy-savings potential under optimum circumstances. Figures are based on manufacturer estimates. Actual savings may vary.

Source: California Energy Commission/U.S. Department of Energy/Electric Power Research Institute

Other Lighting Technologies

Your lighting needs may be suited to other technologies involving advanced controls or alternative lighting equipment. Many fixtures can simply have some of the lamps removed with installation of reflectors. You may have exterior lighting suited to installation of low-pressure sodium fixtures, which are efficient types of lighting used when lighting quality is not important at all. You can find out about these and other technologies by calling the toll-free ENERGY STAR hotline at 1-888-STAR YES.

Take the First Step Toward Implementation

The following steps will help you decide whether you should proceed further with the lighting upgrade project.

1. Do the simple lighting assessment on page 40; or investigate and analyze other opportunities.

Then, calculate simple payback for the project. (Refer to the box below.)

2. Call your local contractor if your simple payback is five years or less.

Remember, you won't save a dime until the new hardware is installed. Every day you wait, you lose money that can never be recovered.

Where Can I Learn More?

Call toll-free 1-888 STAR YES and ask for "small business tech support" or visit lighting products at www.energystar.gov/products.

How To Calculate Simple Payback

The Short Version

$$\text{Simple Payback} = \text{Measure cost} \times 1000 \div [(\text{watts before} - \text{watts after}) \times \text{hours/year} \times \text{energy cost}]$$

Example:

$$\text{Payback} = \$400 \text{ measure cost} \times 1000 \div [(500\text{w before} - 100\text{w after}) \times 6000 \text{ hrs/yr use} \times \$0.08/\text{kWh}] = 2.1 \text{ years}$$

Success Stories

Energy for the Kids at Sligo Adventist School

When Kenneth Gair, Plant Manager for the Sligo Adventist School, talks about his involvement with EPA's ENERGY STAR program, his face lights up. He has good reasons to smile—his facility received an ENERGY STAR Partner of the Year award in 1995 for the work done to upgrade the lighting system in the school. Maybe his best reason to smile is that all the wasted energy that went into inefficient lighting systems now helps to power the school's new computer lab!

The lighting system at Sligo was more than 30 years old and very inefficient. Gair decided to upgrade the system by starting with the areas that would give him the quickest payback. He started with the hallways by replacing incandescent lamps with T-8 lamps and electronic ballasts. This upgrade improved light levels and certainly caught everyone's attention. People were very happy with their new working environment. He then moved on to the cafeteria and the gym. Both areas were lit with 300-watt incandescent lamps, which he replaced with metal halides. In the gym, for example, he replaced 36 300-watt incandescent lamps with 10 400-watt metal halides. Mr. Gair also upgraded outside lighting to high-pressure sodium fixtures.

Classroom lighting was upgraded to T-8 lamps, and electronic ballasts and sensors were added to each room. The hardest part about installing the sensors, Gair says, was fine-tuning the sensitivity and the delay time of the sensor. At first he got a few complaints from teachers and students because the lights would typically go off in the afternoon when teachers were alone in their rooms. Gair was able to establish the right delay time to have the classrooms lit when needed and to ensure that the lights would only be off when they were supposed to be off.

Technical information for carrying out the program came mostly from the ENERGY STAR program. Gair received a video explaining the

significance of sensors and how to choose the right one for his application. He used passive infrared sensors in the classrooms and ultrasonic sensors for the restrooms.

Gair used several innovative ways to fund his upgrades. He gained the support of the school's Parent Teacher Council and used the money he received to finance his first project. Then he applied for rebates at his local utility. The money from the rebate was then funneled back to the next project, and so on. Gair was able to do most of the work himself. He managed to get extra labor at an affordable price by hiring high school students from the neighboring school.

Now that Gair has completed the lighting stage of the program (Stage One), he is looking into window replacement (Stage Three) and heating and cooling system upgrades (Stages Four and Five). Although these will be more expensive upgrades, the success of his early project will help Gair show that energy efficiency really does pay.

When we asked about his next project, he happily marched us to the schoolyard to show us an all-recycled playground!



Building Tune-Up

All cars should get tune-ups or an oil change every few thousand miles to keep them running smoothly and to help them last longer. When was the last time you gave your building and equipment a tune-up? You'll get the same kind of savings with a building tune-up as you would with an automobile tune-up—modest savings at a low cost—and an opportunity to extend the life of your investment. Every once in a while you can even get a boost in horsepower.

Check your timers and thermostats. Did you adjust them for daylight saving time? What about the last time there was a power outage? Did your weekly calendar compensate for last February 29? Does the temperature seem right? Most mechanical timers won't correct for power outages. Resetting them will improve comfort and save you some money. Ask your heating contractor to recalibrate your thermostat the next time they visit.

Check your filters. Unless the filters are inaccessible, you don't need to call your heating and cooling contractor out for an expensive visit just to make sure you have clean filters. Check the filters every month or two. Each dirty \$2 filter you replace will make your air cleaner, work your fan less, and keep the inside of the system cleaner so that it operates more efficiently. Although a new filter might only cost \$2, each dirty filter can cost you \$5 a month in extra energy consumption and can decrease the life of your system.

Check your bills. Do you know how much your electric bill is now compared to a year earlier? Once or twice a year, take time to look at and

compare your bills. Perhaps compare them with your next door neighbor's bills as well.



A low cost tune-up of your building and equipment will save money on energy costs, extend the life of your investment and keep your tenants happy.

Success Stories

Something To Dance About

During a periodic review, a dance studio manager in New York City noticed that his total electric bill had gradually increased to the point of doubling over the course of a year. He was now paying about \$500 per month instead of the \$250 he used to pay. His business hadn't changed and the rates looked about the same, so he called the local utility for help. The utility company sent out an energy auditor who performed a free assessment. The auditor concluded that wiring inadvertently allowed the expanding business next door to use the studio's power. That 5-minute comparison and free assessment saved the studio \$200 per month!

Office Equipment

There are a lot of mysterious things about computers, but energy use isn't one of them. The computer that sits on your desk may look innocent enough, but it silently consumes \$40 per year in electricity. Although \$40 isn't enough money for you to justify throwing out your old computer and buying a new efficient one, it is enough money that you should consider energy use when you shop for a new computer.

Office equipment is the fastest growing electrical load in the business world. Unfortunately, computers, faxes, printers, and copiers waste energy when they remain on and idle. To reduce this waste of energy and the pollution associated with it, manufacturers of just about every major brand of office equipment have partnered with EPA to introduce ENERGY STAR-labeled machines that will automatically power down when not in use. The chart on this page shows the typical savings you may achieve if you buy ENERGY STAR-labeled office equipment instead of its inefficient equivalents.

It does add up. What would happen to your profits if you could cut all of your costs by 50 percent?

In addition to its direct energy consumption, office equipment gives off heat. Your air-conditioning unit must work harder to remove this unwanted heat. Introducing energy-efficient office equipment provides the added benefit of lowering utility bills due to reduced air-conditioning loads. This is Stage Three of the ENERGY STAR program. Some of the savings will be given back in the winter.

Here's the kicker: You don't have to spend anything extra to get this savings. You also don't have to sacrifice any performance, and payback time is 0.0 years. Your choices remain virtually the same as before because so many major manufacturers have chosen to join ENERGY STAR. Just specify ENERGY STAR products or look for the logo on display models. ENERGY STAR offers a number of informational fact sheets and brochures on ENERGY STAR office equipment and maintains a detailed list of qualified products that is updated monthly. For information on ENERGY STAR-labeled office equipment, visit www.energystar.gov/products.

I Don't Want To Wait To Save

Modify user behavior so that it includes turning off computers, printers, and copiers at night, over the weekend, and even when the equipment is not being used for a considerable amount of time.

Energy-efficient office equipment can lower utility bills due to reduced air-conditioning loads, as well as the lower energy cost of the equipment itself.

Typical Savings If You Buy ENERGY STAR-Labeled Office Equipment

Office Equipment	Annual ENERGY STAR-Labeled Office Equipment Cost Savings	Percentage of Total Operating Cost
Computer	\$19	49%
Fax Machine	\$13	52%
Printer	\$39	65%
Copier (Medium)	\$57	57%
Copier (Large)	\$130	58%

Consider networking your computers to share printers so that fewer printers remain idle during the day.

Your computer may already have energy saver software installed; if so, make sure that it is enabled.

How Does It Work?

The following facts on ENERGY STAR office equipment will help you to be a better shopper and decisionmaker when buying and operating new equipment.

Computers. ENERGY STAR-labeled computers automatically power down to 30 watts or less when not in use and are available from almost every manufacturer. To optimize your ENERGY STAR-labeled computer, make sure that the power management feature is enabled and that you have set it to the shortest acceptable time for your operation. Laptops use less energy than desktops.

Monitors. These are among the biggest savers. When not in use, ENERGY STAR-labeled monitors automatically power down to 30 watts or less. If you are going to implement a screen saver, make sure you select one that is compatible with the monitor's power management feature. Most screen savers available in the market actually prevent the monitor from going into sleep mode. Furthermore, turning monitors off at night and during the

What You Will Save

	Energy Savings (kWh/yr)	Cost Savings per Year at Different Electric Rates (\$/kWh)			Percent Savings
		\$0.06	\$0.08	\$0.10	
Save Now					
Turn 24-hour equipment off at night so it runs only 9 hours per day.					
Savings per Computer	675	\$41	\$54	\$68	61%
Savings per Large Copier	6,600	\$396	\$528	\$660	56%
Save Later					
Replace older 24-hour equipment with new ENERGY STAR equipment that is used 9 hours per day.					
Savings per Computer	795	\$48	\$64	\$80	72%
Savings per Large Copier	8,910	\$535	\$713	\$891	75%

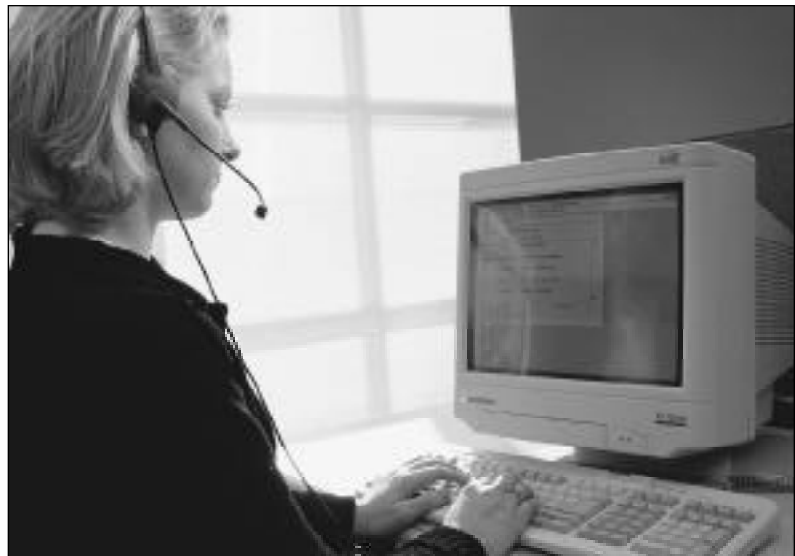

Make the Right Call. A typical 20-computer telemarketing center uses a lot of energy for computers and cooling. ENERGY STAR-labeled computers would cut the annual electric bills by about \$500.

weekend is a practice that will provide you dual benefits. It not only reduces energy costs but in fact extends the life of the units by preserving the phosphorus substance that screen savers were designed to save. Finally, when buying a new monitor, consider the size of the unit as part of your purchasing criteria. Large monitors use more energy, so buy the smallest monitor that suits your operation.

Copiers. Approximately 7 million copiers are in use in homes and businesses across the United States. Copiers are the most energy-intensive type of office equipment, because they sit idle for long periods of time. ENERGY STAR-labeled copiers are equipped with a feature that allows them to automatically turn off after a period of inactivity, which reduces their annual electricity costs by more than 60 percent. There are also several strategies that you can implement regardless of the type of copier you operate. You can purchase a correctly sized copier, use the 1- to 2-sided copy option to ensure that the duplexing feature is being used, and run copies in batches to decrease the time your copier spends in the high-powered mode.

Printers. ENERGY STAR-labeled printers can cut your electricity use by over 65 percent. ENERGY STAR-labeled printers that have double-sided printing capabilities will reduce your paper costs by \$30 a month and paper use, which also helps to save trees. Networking one printer for several users is one of the best strategies you can implement to reduce energy consumption and save your business money. Not only will you benefit from reducing your energy costs, but you will also lower your capital expenditures by purchasing fewer printers. ENERGY STAR printers also automatically power down to less than 10 to 100 watts, depending on the number of pages per minute produced and printer type (i.e., standard-sized, color, large/wide-

format, and impact). This automatic “power-down” feature cuts the printer's electricity use. Using the power-management feature means your printer will produce less heat. This contributes to a cooler and more comfortable work space, and reduces air-conditioning costs. By generating less heat, your printer may last longer and be more reliable.

Facsimile Machines. Because fax machines remain on 24 hours a day, they hold huge energy savings potential—up to 50 percent. ENERGY STAR-labeled fax machines save energy in two ways. They go into sleep mode after being idle for a set period of time, and they scan double-sided pages. You will not miss any faxes if the fax machine goes into sleep mode. For example, a medium-speed ENERGY STAR-labeled fax machine uses 25 percent less energy in sleep mode than in standby mode when it is immediately ready to send/receive faxes.

Scanners. Scanners are one of the fastest growing segments of the office equipment market. ENERGY STAR-labeled scanners enter “sleep” mode after 15 minutes of idle time, which saves energy and money on utility bills.

Multifunctional Devices. The ENERGY STAR program also qualifies multifunctional devices. A multifunction device's primary function is copying, but it is also able to print, fax, or both. ENERGY STAR-labeled multifunction devices power down to a low-power mode then a sleep mode when not in use. Many small businesses are taking advantage of this type of equipment, so you should make sure you always look for the ENERGY STAR label when purchasing this type of office equipment.



Networking several computers to one printer can reduce energy consumption and save your business money.

If everyone used the double-sided feature of ENERGY STAR labeled copiers, we could save one million tons of paper – enough to go around the world 1,400 times.

Paper

You may not think of your paper use as an area to save energy, but it is. Paper producers in this country buy more than \$3.5 billion of energy each year. In fact, every \$5 ream of paper you avoid using eliminates about \$0.34 worth of energy production and related emissions by a paper mill, not to mention the energy spent to harvest and ship the trees and to ship the paper to your desk. In this section, we review simple steps to optimize your use of this valuable resource. You will save money, reduce waste, and protect our nation's forests so they can be enjoyed by generations to come.

Double-Sided Copying

Copy machines often have the capability to automatically copy on both sides of a piece of paper. Selecting 2-sided copying for long documents, articles, or drafts can instantly reduce your paper use without adding any associated inconvenience. For more information, see the chart on this page.

Recycled Paper

Many paper products currently contain some recycled content. Recycling allows fibers to be reused in the production cycle so that fewer trees are required to provide the same amount of paper. Cardboard and newsprint may contain as much as 75 percent recycled content, while standard copy paper often has less than 5 percent recycled content. Selecting papers with high recycled content can be the simplest way you can help preserve our forests.

Recycled papers and other products are rated by their "post-consumer content" and "total recycled content." These percentages are usually in very small print on the paper packages. "Post-consumer content" is the more important factor and refers to fibers that have been used and are then collected through recycling programs. "Total recycled content" refers to the total nonvirgin content of the paper, including production scraps and post-consumer fibers. Paper does not have to be conspicuously labeled "environmentally friendly" to have a high recycled content, so a little research can identify some real bargains.

Paper can have a high recycled content even if it is not conspicuously labeled "environmentally friendly."

Double-Sided Copying Makes Great Business Sense Because It:

- Reduces the amount and cost of paper used.
- Lowers mailing costs because the paper amount and weight are reduced.
- Produces less paper output, which takes up less storage space in offices.
- Often has a more professional appearance.
- Reduces the environmental impacts of paper throughout the paper production process; therefore, fewer trees are harvested, there are lower chemical and energy inputs during pulping, and transportation and storage costs are reduced.
- Shows a business' commitment to environmental protection.

Andrew Duncan, *Greening of the Campus Conference Proceedings*. Ball State University, Indiana. 1996. Page 162.



Conserving paper is an important step in saving energy, lowering pollution, and ensuring the long-term health of our forests.

Energy for Paper Production and Use

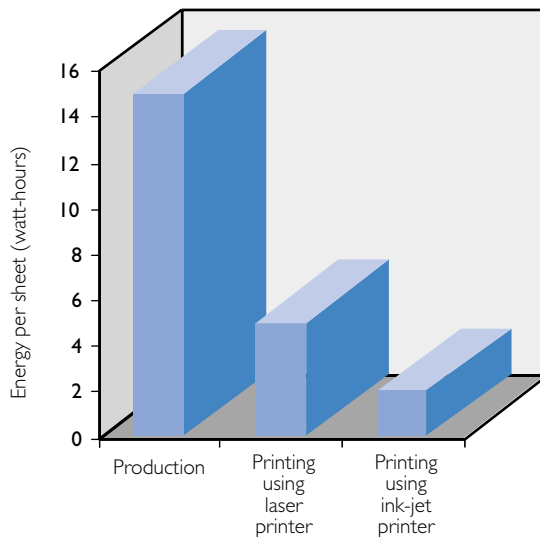

Recycling

Many municipalities sponsor programs to collect paper and fiber products such as corrugated cardboard, paper-board (cereal boxes), white, colored, or glossy paper, newsprint, and books bound with glue. Collecting and returning your used paper to a recycling center will return that fiber for reuse and may reduce your waste disposal costs. If you are a large user of one or more of these products, you can set up your own collection program with a local salvage company. You will be paid by the ton for the materials that you collect, and you will save from reduced disposal costs.

Be sure to include a statement such as “Printed on 50 percent recycled paper containing 20 percent post-consumer waste” on printed materials to highlight your company’s commitment to the environment.

There are also creative ways that companies are reducing their paper use and streamlining their operations. Some items that are routinely issued as memos to all employees can simply be posted on area bulletin boards. And instead of making a copy for each person, you can circulate many documents using a routing tag containing the names of relevant personnel. An employee checks off his or her name and passes the material to the next person on the list.

Many businesses have revolutionized their operations through corporate e-mail and local area networks (LANs). In addition to greatly improving internal communication and facilitating team projects, these tools can significantly reduce paper use by replacing memos, time sheets, forms, and draft documents.

Water Heaters and Water Use

Most small businesses use hot water even if only for employee hand washing. Restaurants, hotels, and other businesses that use hot water for business purposes such as dishwashing and doing laundry can spend 25 percent or more of their total energy bill on hot water. Fortunately there are many low-cost, easy-to-apply methods for reducing your hot water costs.

Water Heaters

Turn off your water heater. Although this may seem obvious, it really is a great idea. Buy a 7-day thermostat (you can get one for about \$30) to turn off your electric water heater at night and on weekends and to turn it back on one hour before your business starts up in the morning. If you have a big water heater, you can get even more aggressive and turn it off an hour or two before quitting time. The already-heated water will be sufficient for late-day needs. You'll save anywhere from \$10 to \$50 per year with a water heater timer.

Along the same lines, consider shutting off a dedicated water heater that is rarely used and turning it on only when it is needed.

If you use a circulating pump, be sure that it is shut off when the facility is unoccupied. Again, a timer will help you remember. Circulating pumps increase heat loss through pipes that circulate hot water. A 1/8 horsepower pump that is turned off for 2,000 hours per year will save you \$25 in pump energy alone.

Lower the thermostat setting. The hotter the water temperature, the faster you lose energy through the pipes and water heater tank walls. Therefore, lower the thermostat to provide hot water at the lowest acceptable temperature. Some tasks, such as doing laundry or washing dishes, and some businesses, such as health care facilities, require higher water temperatures than others. These temperatures may be set by state and local codes. A small office with an electric water heater that is used only for hand-washing purposes would save about \$10 per year if the setting is changed from 130 degrees to 120 degrees at no cost. See the chart on page 58 for some recommended hot water temperatures.

If one task, such as laundry, requires significantly higher temperatures than other tasks, it may be more efficient to reconfigure your piping to include a blending valve. (The hottest water should be piped directly from the heater to the high-temperature task; the water for the remaining tasks should branch off and pass through a blending valve, which mixes in cold

The hotter the water temperature, the quicker you can lose energy through the pipes and water heater tank walls.

Summary

To optimize energy use of your water heater:

- Minimize hot water use.
- Provide hot water at the lowest temperature that is acceptable for the task.
- Insulate the tank and pipes.
- Obtain hot water from the most efficient sources.
- Perform periodic maintenance procedures.

Typical Recommended Hot Water Temperatures

Process	Temperature (degrees Fahrenheit)
Hand Washing	105
Showers	110
Laundry *	160
Dishwasher Rinse **	180–195

* Check code requirements.

** Many dishwashers have booster heaters. Check with the manufacturer to determine minimum temperature requirements.

Source: American Society of Heating, Refrigeration, and Air-Conditioning Engineers

water to reduce the water temperature for the other tasks.) Alternatively, you may wish to install separate heaters for high-temperature and low-temperature tasks or to provide booster heaters for high-temperature tasks. Some machines provide their own booster-heating mechanisms.

Insulate your tank. To reduce heat losses in your hot water system, make sure that your hot water storage tank and the hot water pipes connected to it are insulated. Few hot water tanks are totally uninsulated nowadays.

Move your water heater. If you are remodeling, take the opportunity to relocate your water heater as close as possible to the main point of water consumption. This will reduce heat loss from the pipes.

Buy a new water heater. If you buy a new water heater, be sure to consult the EnergyGuide label on the appliance so that you select an efficient model. Consider using a heat pump water heater, particularly in situations where the simultaneous cooling it would provide would be useful. A relatively new and more efficient technology, heat pump water heaters remove heat from the surrounding air and transfer it to the water. Because these water heaters also cool and dehumidify the surrounding air, they are particularly beneficial in warm,

humid areas such as kitchens and laundry rooms. Another excellent alternative is tankless, instantaneous, on-demand water heaters, which are quite popular in Europe. They are growing in popularity here, too, especially in areas where relatively small amounts of hot water are used on occasion. Tankless water heaters eliminate tank losses and are great for office buildings that only have sinks. Tankless water heaters typically supply up to two gallons per minute of hot water, about the same as required for a shower and more than enough for most office sinks. One catch is that they may require heavier wiring, so check with your contractor before making a decision.

Or, don't buy a new water heater. Consider turning your standard water off except for emergencies and using "free" waste heat recovery to meet some of your water heating needs. Waste heat sources include laundry or dishwashing rinse water, steam condensate lines, and refrigeration equipment.

Maintenance

To maximize savings and keep your hot water system operating efficiently, you should perform periodic maintenance procedures. Storage-type water heater tanks should be flushed out about annually to remove sediments that reduce system efficiency. (Flushing involves opening the drain valve at the bottom of the tank and drawing off water until the water runs clear. Follow your manufacturer's instructions. In areas with high mineral content in the water, you may need to do this more often.) The burners of gas- or oil-fired water heaters should be tested and adjusted annually to make sure that the fuel is being burned as efficiently as possible. In addition, it is good practice to periodically flush your fixtures with very hot water to control bacteria growth.

Before you buy a new water heater, consult the EnergyGuide label so that you select an efficient model.

Solar Water Heating

You really can't do any better than solar energy for energy savings and for the environment. Solar water heaters are simple devices that capture the sun's energy to heat water for ordinary use. They are often piped directly into systems with conventional water heaters, lowering your energy costs while still providing hot water on overcast days. Solar water heaters are extremely cost effective for heating swimming pools, where other types of heating can be very expensive.

Solar water heating is an established technology used throughout the world. In California, solar systems are the only type of pool water heating allowed by many local codes. Even the pool built for the Atlanta Olympics is heated with a solar system, though this was a unique, showcase system. While you may think of the large number of units in sunny areas like Florida or California, you may be surprised that even in the rainy areas of the Pacific Northwest, solar water heaters can pay for themselves in less than 10 years. Check with your local utility, your state energy office, and your tax preparer to find out about incentives or tax benefits that apply to solar energy systems. You can get more information, locate a solar installer, or find a supplier for a do-it-yourself system by contacting the American Solar Energy Society at (303) 443-3130 (www.ases.org) or the Solar Energy Industries Association at (202) 628-7745 (www.seia.org).

Water Use

You may wonder why an energy manual is discussing water use. Certainly within your own facility it costs money to heat the water. But the water company also spends a lot of money on energy to pump and purify the water it delivers to you. So a portion of your water bill is actually an

energy bill. The same logic holds true for sewage treatment. If you have a business such as a restaurant, bakery, food-processing plant, hotel, nursing home, or laundry and your business uses large amounts of water, you will benefit even more from water use optimization.

Like everything else, savings from water measures can vary. You can save on the cost of the water, you can save on sewage, and you also can save on energy costs for pumping or heating processes. Because savings come from so many sources, water reduction upgrades are frequently profitable.

Efficient showerheads and faucet aerators are inexpensive devices (they generally cost between \$2 and \$20) that screw into existing pipe fittings to help reduce water consumption. These devices reduce the amount of water used in common daily tasks. If your business is a hotel, motel, or restaurant, you can use these devices to significantly reduce your water-heating bills as well as your water bills.

By repairing a seal that leaks a drop of electrically heated hot water every five seconds, you can save about 400 gallons of water, 85 kilowatt-hours

Solar water heaters use the sun's energy to heat water and can help you lower your energy costs.



Solar water heaters are simple devices that capture the sun's energy to heat water for ordinary use. They are often piped directly into systems with conventional water heaters, lowering your energy costs while still providing hot water on overcast days

Success Stories

Water Heater Tune-Up

Consider the case of an office manager of a 2,000-sq.ft. office building who discovered a leak in the pipes from a 40-gallon electric water heater. While repairing the leak, she decided to install an insulated blanket wrap around the water heater to prevent additional heat loss. The cost of the installation, the insulation, and the repair was approximately \$40. By setting the water heater thermostat to a setpoint of 120 degrees Fahrenheit, the office manager saved \$35 per year and had a 1-year payback. That extra \$35 goes to business profit year after year.

Repairing a seal that leaks a drop of electrically heated hot water every five seconds can save you about 400 gallons of water, 85 kilowatt-hours of electricity, 125 pounds of carbon dioxide, and \$10 per year.

(kWhs) of electricity, 125 pounds of carbon dioxide, and \$10 per year.

Automatic controls such as valves or springs with sensors that turn faucets off can also help save water. The spring-loaded valves will automatically turn the water off when the user releases the handle. Photocell-equipped sensors are gaining popularity in controlling water use in restrooms. Almost all major airports have installed them due to their high intensity of use and because luggage and other articles tend to tie up travelers' hands. These sensors detect motion and shut the water off after the user leaves.

The amount of water used when flushing toilets can be drastically reduced without compromising efficacy by using new-design, low-volume toilet fittings. These fittings can reduce the amount of water used per flush by about 66 percent by using improved water flow characteristics. High-quality, pressurized, low-volume toilets tend to cost about \$200 more than gravity toilets, but they are worth the premium if the toilets will be flushed more than 20 times per day.

New washing machines with a horizontal axis design use much less water than the older types of washing

machines. The new machines can help save water as well as reduce water heating costs for laundries, hotels, and nursing homes. They also can reduce the amount of detergent that is used for washing the same amount of clothes. The newer design machines occupy less space and do not produce as much heat as the older design washing machines, which use much more hot water; thus, your rent and air-conditioning requirements can also be reduced. New machines also remove more water from the laundry during the spin cycle, thereby greatly reducing drying time and energy use.

Xeriscaping and Gray Water

Wouldn't you rather be having fun in the summer instead of taking care of the landscaping around your facility? Xeriscaping (*xer* means "dry," from Greek) is the technique of utilizing native, hardy, low-maintenance plants for landscaping. Xeriscaping can save you money on your water and maintenance costs. And because native plants cope better with your particular soil, climate, and insects, they require fewer pesticides and less fertilizer (something your 4-legged neighbors and feathered friends will appreciate). A general Internet search for "Xeriscape" will provide many resources, including several state programs. Also visit www.greenbuilder.com/sourcebook/xeriscape.html and www.xeriscape.org.

We also recommend:

- Colorado Spring Utilities (Xeriscape Demonstration Garden): www.csu.org/xeri.
- South West Florida Water Management District (Xeriscape): www.swfwmd.state.fl.us/conservation/xeris/swfxeris.html.
- Green Building Program (Sustainable Building Sourcebook): www.greenbuilder.com/sourcebook/xeriscape.html.

Water from sinks or washing machines that may contain soap but is otherwise still clean is called “gray water.” Many drought-prone areas of the country have encouraged use of this gray water for landscaping purposes. St. Petersburg, FL, has even installed a city-wide system that provides reclaimed water for 7,000 homes and businesses. Other cities do not permit reuse of gray water at all because of water quality concerns. For more information on promotional programs or restrictions on gray water use, call your local building permits office or check out the EPA Web site at www.epa.gov.

If your business is involved in any type of manufacturing or processing that uses water, you should consider reusing the waste water in some other process where your water quality requirements are not as stringent. For example, a growing microbrewery in Portland, OR, implemented an upgrade in 1992 that allows it to use its extra processing water for washdown. The plumbing was tricky, but the upgrade was ultimately very low in cost and saved a lot of natural gas.

Where Can I Learn More?

If you want more information on smart water heating, the Gas Manufacturers Association publishes a *Consumers’ Directory of Certified Efficiency Ratings* for electric, gas, and propane water heaters.

We also recommend:

- Department of Energy: <http://www.eren.doe.gov/erec/factsheets/watheath.html>.
- Indoor Water Efficiency Spreadsheet (contains information on calculating energy savings): (413) 253-1520; <http://solstice.crest.org/environment/gotwh/general/indoor-water/index.html>.
- Iowa Energy Center (for information about buying, installing, and upgrading hot water systems): <http://www.energy.iastate.edu/>.
- Water Wiser, The Water Efficiency Clearinghouse (for information on water efficiency and conservation): 1-800-559-9855; www.waterwiser.org.
- Wisconsin Energy Bureau (for general information on water heaters plus a compilation of the GMA ratings): www.doa.state.wi.us/depb/boe/index.asp.

Businesses involved in any type of manufacturing or processing that uses water should consider reusing the waste water in some other processes where water quality requirements are not as stringent.

Success Stories

Community Mercantile, an 18,000 sq.ft. grocery in Lawrence, KS, is saving about \$55,000 yearly, and the 714,286 kWh saved will prevent about 1,002,857 pounds of carbon dioxide emissions. Andy Lewis, owner, says, "I was frankly amazed at the quality of savings, and how that translated into coal not being burned and carbon dioxide and sulfur not being released into the atmosphere." The upgrade included high efficiency HVAC units, programmable thermostats, a new white, reflective roof, more insulation, T-8 fluorescent lamps with solid-state ballasts, low-E insulated windows, refrigerated case covers, "tankless" water heaters, compact fluorescent lamps (CFLs), and LED exit signs.

Refrigeration

Refrigeration equipment is one of the highest energy users in the competitive, low-margin supermarket, convenience store, deli, and restaurant businesses. Upgrades that reduce your refrigeration costs can make your small business more competitive.

There have been many great developments over the past 25 years to make refrigeration systems more efficient. The down side of all these innovations is keeping up with them. Big chains have experts with full-time responsibility for such matters. You don't. So look for help. If your equipment is more than 10 years old, call a local refrigeration case supplier and request a checkup. You'll be surprised at all the possibilities. A typical new residential refrigerator uses about 800 kilowatt-hours per year and costs about \$64 per year to run. This is *less than half* what you'd pay for the same size unit that is 20 years old.

No-Cost Action Items for the Refrigeration Amateur

Keep the doors shut. Repeated fluctuations in temperature will damage your food quality and will cost you money.

Check the temperature settings. If your settings are lower than necessary, chances are you are wasting energy. The most common recommended settings are between -14 degrees and -8 degrees Fahrenheit for freezers and between 35 degrees and 38 degrees Fahrenheit for refrigerators.

Properly load your refrigerator. Overloaded units disrupt air flow necessary to cool the products effi-

ciently, and allows deterioration to occur. On the other hand, underloaded units waste energy. If you have partially filled units, consolidate them.

Properly position refrigeration units. Don't put your soda display case right next to your deli bun warmer or in direct sunlight. Extra heat makes your refrigerator work harder to maintain the desired cool temperature. Make sure that there is enough ventilation for your refrigerator's mechanical equipment. A 1-inch gap on the sides and a 4-inch gap at the back are recommended for refrigeration units to allow the condenser and fan to have access to a steady flow of air.

Clean the cooling coils. Dirt accumulation impairs heat transfer and lowers refrigeration efficiency and capacity.

Check the door seals. Tight seals and properly closing doors prevent warm air from entering the unit, which reduces cooling energy and prevents frost buildup. Use this rule of thumb: If you can easily slide a dollar bill into the seal, have the seal adjusted.

The above actions can save you between \$5 and \$25 per year. These actions can also improve your product quality and extend the unit life. At no cost except a few minutes of

ENERGY STAR Commercial Refrigerator

A new Energy Star Commercial Refrigerator (50 cubic feet) uses about 2,500 kilowatt-hours per year and costs about \$205 dollars a year (@\$.08/kWh) to run. Compared to standard commercial refrigerators, that is about 30 percent in savings!

Success Stories

Inn at Wiccoppee

Rick Stein owns and operates the Inn at Wiccoppee, a well-known restaurant in the quaint Hudson River area of Hopewell Junction, NY. With a free energy audit and advice from his local utility, Central Hudson Gas and Electric, Stein is saving \$1,869 annually and preventing about 25,000 pounds of pollution. His payback on upgrade costs was about seven months.

Stein's biggest single savings opportunity cost him nothing to implement. He reduced his frozen food inventory and combined it into two freezers, allowing him to unplug three other freezers. And while this simple move didn't affect the restaurant at all, Stein is saving almost \$800 a year, money that goes straight to his bottom line.

Other savings required small investments but delivered good savings. These included a lighting upgrade, and replacing an electric deep fryer with a similar natural gas (or propane) fired unit, because these fuels are cheaper than electricity.

ENERGYGUIDE

Compare the Energy Use of this Refrigerator with Others Before You Buy.

This Model Uses
776kWh/year

Energy use (kWh/year) range of all similar models

Uses Least Energy	Uses Most Energy
776	1467

Refrigerators using more energy cost more to operate. This model's estimated yearly operating cost is:

\$64

Use the EnergyGuide label to select efficient residential-size refrigerators. (Also available for other appliances.)

Refrigeration heat recovery to water heaters or spaces is almost standard now in grocery stores with substantial hot water needs.

your time, these actions are a bargain.

Shorten defrost cycles. This is starting to get a bit technical. Fifteen minutes an hour isn't perfect for everyone or for every season. If you're in a dry climate or season, gradually decrease your defrost cycle time until you see hints of frost buildup on the coils. Back the setting up a bit, and you are optimized. This procedure, like others, can help extend the unit life.

Refrigeration Capital Investments

Specify glass doors when you buy new display cases. They bring a modern look to your store and keep cold air where you want it (with the food) and warm air on your customers. If you can find a low-cost contractor, upgrading your open display cases by adding glass doors to them will reduce your energy costs by as much as 40 to 50 percent.

Request a humidistat instead of a timer to control the anti-sweat heaters in large display cases. This is similar to the defrost cycle idea mentioned earlier, but it involves automation.

Upgrade your "rack" system with a floating head pressure system. These pressure systems allow the compressor to work less when it is cool outside, and they consistently demonstrate savings of 20 to 30 percent.

Heat recovery to water heaters or spaces is almost standard now in grocery stores that have large systems with substantial hot water needs, such as delicatessens. In most cases, you can disconnect your old water heater.

Order new units with efficient lighting for new display cases. The

lower wattage lights will reduce cooling costs by reducing the work done by the compressor to cool the heat generated by the lamp and may even improve the product appearance.

If you are in the market for a new refrigerator, look for the ENERGY STAR® logo—your guarantee of savings. And use the EnergyGuide label to help you identify how a particular model compares with others in the market and what its annual operating costs are. You can then base your purchasing decisions on the price you can afford to pay and the highest efficiency available in that range. Calculate the simple payback for the cost premium to see how much increased efficiency you should buy.

Specify high-efficiency evaporator fans when buying new display cases.

At less than 1/10 horsepower, you wouldn't think that these little fans are a very big deal, but when considering that a grocer may use a hundred of them, it adds up. It is normally worth paying the incremental price premium when buying a new unit.

Purchase freezers and refrigerators with an Energy Efficiency Ratio between seven to nine for medium-temperature systems and from five to six for low-temperature systems.

A Note About CFCs

The major challenge that the refrigeration industry has faced is the mandated phaseout of chlorofluorocarbons (CFCs). Until recently, many refrigerators used CFC-based refrigerants. The foam insulation built into older refrigerators also contains CFCs. Because CFCs deplete the ozone layer and contribute to global warming, new refrigerants have been developed to replace CFCs and are currently available in new units or as replacements for CFCs in old units. Call the EPA Stratospheric Ozone Hotline at 1-800-296-1996 for information on converting your existing refrigerators or disposal methods.

Building Construction

The phrase “set in stone” is frequently used to describe things that cannot be changed and must be accepted as a fact of life. This may be how you view your building’s construction and the way it affects your energy bill. Just because your building is set on a firm foundation doesn’t mean that you can’t make some changes—large or small—that can reduce the impact that your building’s exterior has on what you pay to heat and cool it. What’s more, most of the changes you make to reduce your energy costs will also bring along improvements in comfort and in your building’s appearance.

Fortunately there are many small-scale upgrades that you can make to your building’s envelope (the walls, roof, and windows) that can make the building cost less to heat and cool. Unlike the equipment inside your facility, simply changing a wall or a roof just because the original equipment isn’t efficient enough isn’t really a feasible solution. Sometimes windows of opportunity do occur to upgrade your building’s construction at relatively little extra expense. For example, roofs need to be replaced periodically, and the additional expense of adding insulation or reflective coverings at that time can be justified by the savings they will provide. Similarly, energy-saving window upgrades may be worthwhile when your building’s facade is being remodeled to modernize its appearance. In turn, when it is time to replace your heating or cooling system, you may find that by investing some money in wall or roof improvements, you can reduce your building’s heating and cooling needs enough to reduce

the size and cost of the unit equipment you need to buy. Alternatively, if your current system can’t quite heat or cool enough on extreme temperature days but is still new enough that you would rather not replace it, you can make building improvements to reduce your heating and cooling loads enough to allow your current system to meet your needs.

Most of the upgrades that you can make to your facility involve reducing heat losses in winter, reducing heat gains in summer, and reducing air leakage throughout the year. The particular envelope upgrades that make the most sense for your building depend on both the climate and the layout of your facility. A business owner in Phoenix, AZ, will be more concerned about what the summer sun is doing to his cooling bill than he would be if his business were located in Caribou, ME. Similarly, the business owner with a 1-story building will

You can reduce heat losses in winter, reduce heat gains in summer, and reduce air leakage throughout the year by upgrading your facility.

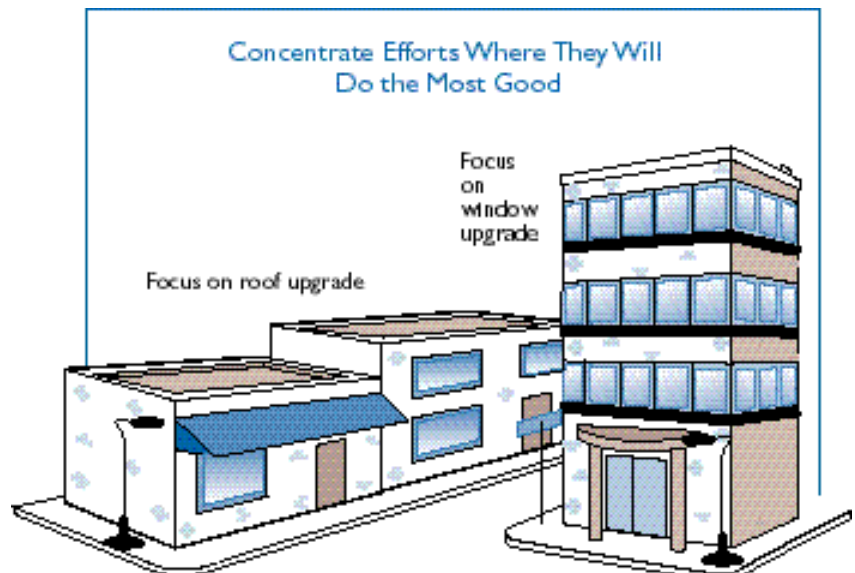



By replacing the existing windows, this Rebuild America partnership school improved indoor comfort while reducing winter heating requirements.

Success Stories

Envelope Modifications Provide “Cool” Savings in Eastern North Carolina

A comfortable atmosphere in the classroom is essential to learning. An elementary school in North Carolina was faced with unbearable heat in the summer and erratic temperatures and drafts in the winter; neither condition was conducive to learning. To help ease the uncomfortable atmosphere, the administrators decided to provide air conditioning by replacing the school’s existing steam heat system with fan coil heating and cooling units that had individual room thermostats. They also replaced the single-pane windows with double-pane windows and insulated panels. The new windows, coupled with insulation added to the roof in an improvement project a few years earlier, reduced the size of the air-conditioning equipment needed, which resulted in a lower installation cost. What was the result of this air-conditioning and window replacement project? The school reduced its heating costs that winter by nearly 35 percent. And the benefits from replacing the windows were not limited to cost savings; the increased comfort levels created by eliminating drafts and the newer, more modern appearance of the school have boosted the teachers’ morale and the children’s pride in their school.

Window R-Values*

Single Pane	1.0
Double Pane	2.0
Triple Pane	2.9

Decrease R-Values by at least 20 percent if aluminum frames.

Increase R-Values by about 30 percent if low emissivity.

* See page 69 for more information on R-Values.

probably be more concerned with roof upgrades than a business owner with a 10-story building because the roof has a much larger impact on the 1-story building.

Windows

Windows are one of the most appealing parts of any building, providing its “look” and, of course, the coveted window offices. But windows are also an area where a lot of your heating and cooling costs can go literally out the window. Windows typically have low insulating levels, as anyone who has sat next to a large, single-pane window on a cold winter day can attest. In addition, windows can also allow a lot of unwanted summer heat gain, especially if they’re located on the west or south side of the building. In recent years, window manufacturers have developed low-emissivity (low-E) windows with dramatically higher insulating values and reduced heat gains, but it is unlikely that these are being used in your building if it was built before 1990.

Unless you have single-pane windows and live in a cold climate, the savings from replacing your windows with more efficient windows are hard to justify financially unless the replacement is done as part of a larger renovation. You can improve the efficiency of your existing windows, however, by installing window films.

Window films are thin coatings that can be applied to the interior surface of windows to help block radiant heat gains and losses. These coatings are similar to those used in low-E windows. Their primary benefit is in reducing summer heat gains, because they can prevent from 61 to 80 percent of the incoming solar radiation from entering your building. In winter these coatings can help reduce heat losses by preventing 19 to 44 percent of

indoor heat from escaping out the window. In addition to providing energy-cost savings, window films improve comfort by moderating heat losses and gains, reducing glare and overheating, increasing privacy by restricting visibility from the outside, improving the appearance of the windows, and reducing the fading of carpets, furniture, and merchandise. Window films typically cost between \$1.35 and \$3.00 per square foot to install, and they generally have a lifetime of 7 to 12 years. They must be installed properly to avoid bubbles, cracks, or damage to your windows.

Window accessories also affect your energy costs. White roller shades and Venetian blinds, when fully drawn, reflect heat. Draperies or curtains, when made of a tightly woven, opaque material in a light, reflective color, can reduce heat gain. If a curtain fits tightly against the window, it can also reduce winter heat losses. Awnings on the south, east, and west sides of your building can reduce summer heat gains; trees planted on the east and west sides of the building can also reduce summer heat gains. The chart below provides the simple guide to when you should use your shades, depending on the season and the time of day.

Pull Your Shades		
DAY		
SUMMER	Down	Block the sun
WINTER	Up	Let in the sun
NIGHT		
SUMMER	Up	Let building heat out
WINTER	Down	Keep building heat in

Roofs and Walls

Your building's roof can generally be improved two ways: by improving the insulation and by improving its reflectivity to reduce heat gains. Your priorities will depend upon the type of building you have and where your business is located. Roofing improvements are generally better investments for buildings that currently have a poorly insulated roof and in locations with extreme temperatures in either summer or winter.

If heating costs are a priority at your facility, or if you work in a warm climate and have an attic, roof insulation could be a good investment. If your business has attic space, insulation may be added at any time to the attic floor at a relatively low cost either by blowing in insulation or by installing batts of insulation on the attic floor. Depending upon the type of roof, insulation may be added on either the inside or the outside of the roof. If you have a flat roof, your best bet will probably be to wait until your roof needs replacement and to install rigid insulation on the roof exterior when the roof is being replaced.

How much insulation is enough? Your state or local building codes will usually require a minimum level of insulation, but keep in mind that this figure is a minimum required amount. Because codes have gradually increased the amount of insulation required, many old buildings will have less than the amount required by current codes. To get a better idea of advisable insulation levels for energy cost savings in your area, check with your state energy office or local electric utility. The American Society of Heating, Refrigerating, and Air-Conditioning Engineers recommends an R-Value between 25 and 30 for optimum energy efficiency. See the chart on page 68 for some roofing rules of thumb.

Roof insulation could be a good investment if heating costs are a priority at your facility or if you work in a warm climate and have an attic.

Roofing Rules of Thumb

Existing Condition	Cost Effective To Add Insulation?
New Construction	Yes, always. R-19 to R-38 depending on location and codes.
Existing Buildings:	
<i>Current Insulation Level</i>	
0-1 inches	Yes, always.
2-4 inches	Yes, if attic is accessible or if built-up roof is being repaired.
5-9 inches	No, in moderate climates. Just add when remodeling. Yes, in extreme climates and where the attic is accessible.
More than 9 inches	No.

When unconditioned air from outside slips into your building, or conditioned air from inside seeps out, you have to pay to heat or cool the extra or replacement air.

If your air conditioner runs significantly more than your heating system, ask your roofing contractor about reflective roof coverings for your area. Recovering the roof with a light-colored stone, coating, or membrane is less expensive than a full roof replacement. The lighter color will cause your roof to absorb less heat and will extend the life of the roof by slowing its deterioration. Another alternative is a roof spray system, which has moisture sensors that control a spray of water over the roof to keep temperatures down. If your building has an attic space, you may be able to install a radiant barrier. A radiant barrier is essentially a layer of aluminum foil that can be tacked to the underside of your roof deck with the shiny side facing down toward the air space in your attic. It blocks 95 percent of the heat that would otherwise be radiated downward from your hot roof deck. All of these options result in lowered roof or attic temperatures, which make your upper floor a much more comfortable place during the summer. In one application in New Orleans, for example, the installation of a radiant barrier and attic vents dropped the attic temperature by 50

degrees. You can imagine the effect on comfort downstairs.

Finally, forced ventilation in attics can drop temperatures by 30 degrees or more for a big increase in comfort and savings.

Reducing Air Infiltration

When unconditioned air from outside slips into your building, or conditioned air seeps out, you have to pay to heat or cool that extra or replacement air. Consequently, it pays to minimize this infiltration, especially because the methods to reduce it are generally inexpensive and easily applied. Reducing infiltration will also improve your occupants' comfort because nobody is comfortable sitting next to a draft.

Use caulk to seal air-leaking cracks and install or replace weather stripping around doors and operable windows. Small air gaps may look inconsequential, but they add up. A 1/8-inch air gap along the opening of a pair of 6-foot-8-inch doors is equivalent to a 10-square-inch hole in the wall. Replace the glass in any broken windows as soon as possible. Make sure all doors and windows close properly and—an often forgotten procedure—cover the exterior portion of any window air conditioners in the winter.

If you have a loading dock, several measures can potentially cut your costs and increase the occupants' comfort and productivity. When the loading dock door is open, make sure that any doors that separate the loading area from the rest of the facility are closed. (If there are no such doors, you may wish to install some.) If the opening is larger than needed, consider making it smaller. Have trucks back up as close as possible to the opening to reduce the amount of heated air escaping the area. If the loading dock door is

regularly left open, install a curtain of plastic strips or an air curtain to help reduce heat loss. Alternatively, consider radiant heaters, as discussed on page 77.

If You Plan To Remodel

Your options for reducing your building’s energy costs are limited to some extent by the choices that were made when your building was built. Making the decision to use energy-efficient windows and appropriate insulation levels is far less expensive when a building addition is still on the drawing board. At this point the actual cost for each upgrade should be considered the incremental cost between the more and less efficient alternatives. The options that provide the best return on investment can be identified by comparing the incremental cost with the energy cost savings that will accrue over the lifetime of the building. Software packages are available and can be used to analyze these choices. If your architect is unfamiliar with these methods, you may wish to hire a consultant to help you make the optimal choices.

Increasing the insulating value of existing walls may be difficult to justify from a cost-savings point of view. If a cold wall is a significant comfort problem, however, you may wish to do so. If you have frame walls, you can have insulation blown into the wall cavities. Otherwise, you can increase the insulating value by adding a layer of insulation over the existing interior wall and covering it with new wallboard. (You will also need to move out any light switches or electric boxes.) This solution will decrease the size of the room slightly. See the figures on this page for variations of wallboard coverings.

Consider installing a vestibule at your primary entrance, particularly if your business sees a lot of visitors. A

Technical Closeup: R-Values

R-Values measure the effectiveness of insulation. The higher an object’s R-Value, the better it resists heat loss (or gain). Heat loss through an object is inversely proportional to its R-Value, so you get more bang for your buck from increasing the R-Value of a building component that initially has a lower R-Value than you would with a higher one. Increasing insulation from R-1 to R-20 will save you a lot more money than increasing from R-20 to R-40. For example, adding an R-Value of 1 to a window that currently has an R-Value of R-1 represents a 50-percent decrease in heat loss; adding R-1 to an R-15 wall decreases its heat loss by 6.25 percent.

vestibule consists of a space between two sets of doors that acts as an airlock to reduce the amount of air that enters or escapes from the building as people enter or leave. You may be able to create one by installing an extra set of doors inside your building, or you may wish to build it as a small addition. This area does not need to be heated or air conditioned. In addition to reducing energy costs, this modification will dramatically increase the comfort of anyone who works near the doors. Studies show that vestibules can reduce related infiltration by more than half. Such a measure likely will not be justifiable solely on energy cost savings unless it is part of a larger upgrade, but it is justifiable when you consider the added comfortable work space it provides.

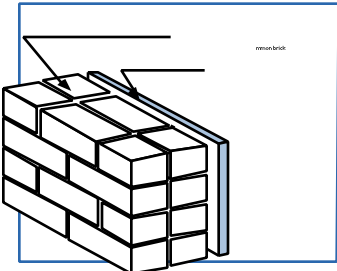

Drawing 1

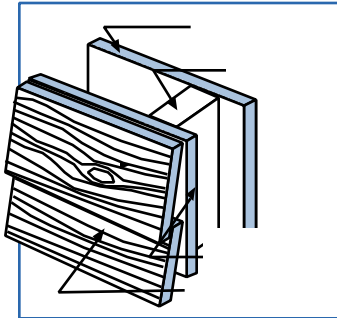

Drawing 2

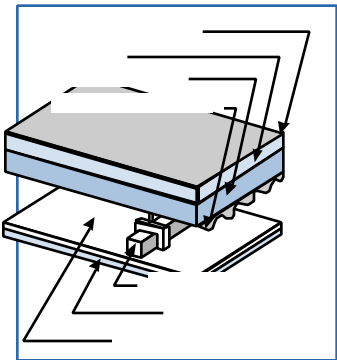

Drawing 3

	R-Value	
	Without Insulation	With Insulation
Drawing 1	R-5	R-12
Drawing 2	R-4	R-8
Drawing 3	R-5	R-9

Heating and Cooling

Heating, ventilating, and air-conditioning (HVAC) systems account for 39 percent of the electric energy used in commercial buildings in the United States. Consequently, almost every business has the potential to realize significant savings by improving its control of HVAC operations and improving the efficiency of the systems it uses through proper design, installation and scheduled maintenance.

1970s-Style Conservation: It Still Works

The most straightforward method for saving on your HVAC bill is simply to operate the systems less, both by turning the systems off (or back) when the building is not occupied and by choosing more efficient temperature setpoints so that the systems run less often.

A week contains 168 hours. If your business operates during only 40, or even 80, of those hours, you occupy your facility during only a fraction of the week. Consequently, savings are available by setting back your thermostat when the building is unoccupied. The term “setting back” is used to indicate both changing the temperature setting (setting back to a lower temperature in winter and setting up to a higher one in summer) and making sure that the fan switch on the thermostat is set to “auto” rather than “on.” A fan left in the “on” mode runs nonstop 24 hours per day; in “auto” mode, the fan cycles on only when heating or cooling is being supplied. In some instances the fan savings can be significant even when only minimal

temperature setback changes are made. If your system draws in ventilation air from outdoors, cycling the fan during unoccupied hours can also help with humidity control in humid areas.

How much can you save? That depends upon your climate, the size and shape of your building, how much you set back your thermostat, and how many hours per week your business operates. Substantial savings are also available by adjusting your temperature setpoints—lower in the winter and higher in the summer. Change your thermostat settings gradually, no more than a degree or so per week, to see how low (or high, for summer) a setting you need to maintain a comfortable facility. Make these changes without advertising the fact that you are doing so to avoid having staffers begin grumbling about changes before they can actually feel them. This method can also help identify problem areas in your system. Check out the areas where you first receive complaints about comfort to determine whether the problem is one of inadequate air supply, excessive drafts, or intense sunlight.

The Consortium for Energy Efficiency (CEE) reports that up to 50 percent more energy could be saved with proper installation, sizing, and maintenance of commercial central air conditioners and heat pumps.

Save on your HVAC bill by turning the systems off (or back) when the building is unoccupied.

Success Stories

Programmable Thermostats Bring Needed Comfort in Seattle

Centerplex, a Seattle-based ENERGY STAR® small business partner, owns a 26,500-sq-ft. commercial office with 43 tenant firms and 100 occupants. Centerplex's owner, Jonathan Pool, has implemented a variety of energy-saving modifications that have reduced his electric bill by 50 percent. Among these modifications is the installation of ten programmable thermostats, which save energy by resetting the heating and cooling setpoints when sections of the facility are unoccupied. The programmable thermostats provide the added benefit of reducing tenant complaints about erratic temperatures. The programmable thermostats, along with energy-efficient lighting and window improvements, have netted a savings of \$23,000 per year within an overall payback period of only 1.5 years. Mr. Pool made an interesting observation about his efficiency efforts and their ultimate effect on his bottom line. "I think there is a spillover effect. When you rent space to others the practices that you engage in attract compatible people. Conservation attracts people who support conservation. They generate less waste and are easier on both each other and the physical plant." His overhead goes down, and his profit goes up.

HVAC Tune-Up

The Air Conditioning Contractors of America recommends scheduled maintenance on your heating and air conditioning systems twice annually by a licensed HVACR contractor. These scheduled maintenance programs and system checks should include the following:

- Check the system's connections.
- Check for proper refrigerant charge (and combustion efficiency where appropriate in the fall.
- Inspect and clean coils, straighten fins, and replace filters.
- Inspect and oil fan motors.
- Inspect and repair ductwork leaks and insulation voids in unconditioned spaces.

- Check for proper ventilation and economizer operation.
- Check for proper airflow at unit and each zone.
- Check for proper control settings and safety shut-down functions.

Note: These maintenance and system checks are just as important as changing the oil in your vehicle every 3,000 miles.

1980s Efficiency Improvements: Programmable Thermostats

Although night-setback and temperature-setpoint changes are simple enough to be done manually, an automatic control is much more efficient and reliable. Electronic, programmable thermostats, which allow you to program in desired setpoint and cutoff times for a 7-day week, are available for \$50 to \$200. Most models include manual override features, so an executive who needs to come in on a Sunday afternoon when the system is in setback mode can override the setback and work in comfort without having to reprogram the system. Be sure to locate the thermostat in a location where the temperature is representative of the entire area served by the system—not next to the air-conditioning diffuser or a coffee pot. Many businesses find it worthwhile to install a locking enclosure around their thermostats to avoid unauthorized tampering with the setpoints. If you have a heat pump, be sure you get a heat-pump-programmable thermostat with a "smart recovery" feature, which will bring your system on early enough to minimize the use of electric strip heating. Heat-pump thermostats cost about twice as much as other thermostats because they have to control multiple types of heating.

1990s and Beyond: Whole-Building Energy Optimization and Management Systems

Programmable thermostats are effective and work quite well, especially with individual-unit air conditioners and heaters. If your facility uses larger, central systems such as boilers and chillers, you may wish to use an energy management system (EMS) instead. As we approach the next millennium, the EMS market will likely expand into smaller and smaller facilities. In addition to the setpoint and night-setback features, which can be handled by a programmable thermostat, an EMS can be used to provide savings in many other ways. Depending on the type of system you have, an EMS might be used to provide some of the following money-saving automatic control functions:

- Consider installing an economizer. There may be times when you need cooling in the building but the outside temperature is low. An economizer allows your system to circulate outdoor air for free cooling during these periods. Rooftop units have had economizer options that can provide free cooling for many years. If your rooftop(s) have economizers, they need to be checked for proper adjustment and operation with your scheduled maintenance. If your rooftop(s) do not have economizers, consider having them installed by your HVACR contractor. The payback period is typically very short.
- Adjust supply-air temperatures based on indoor and outdoor temperature and humidity to let the heating and cooling systems operate most efficiently.

Approximate Percentage Savings From Thermostat Setback

Degree-Days*	Setback Temperature		
	60° F	55° F	50° F
1,000	13%	25%	38%
2,000	12%	24%	36%
3,000	11%	22%	33%
4,000	10%	20%	30%
5,000	9%	19%	28%
6,000	8%	16%	24%
7,000	7%	15%	22%
8,000	7%	13%	19%
9,000	6%	11%	16%
10,000	5%	9%	14%

*Look up your degree-days on the map below or call your utility for exact data. For a definition of "degree-day," see the glossary in section 3.

Savings based on 65 degrees Fahrenheit and assuming setback for 14 hours per weeknight and all weekend.

Source: "Reducing Energy Costs Means a Better Bottom Line." National Frozen Foods Association/U.S. Department of Energy.

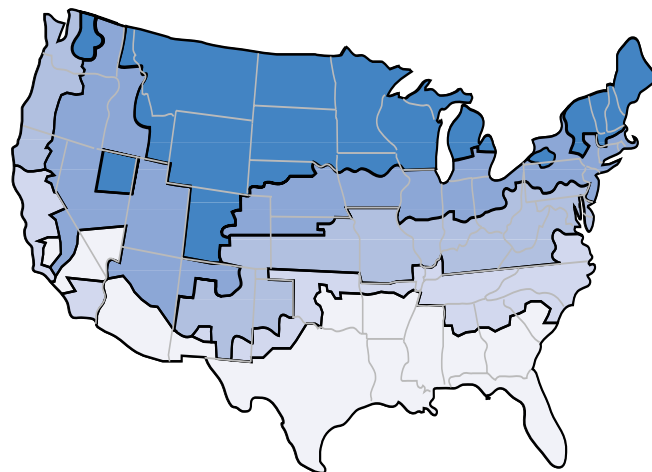

- Zone 1 — Greater than 7,000 heating degree-days
- Zone 2 — Between 5,500 and 7,000 heating degree-days
- Zone 3 — Between 4,000 and 5,500 heating degree-days
- Zone 4 — Less than 4,000 heating degree-days
- Zone 5 — Less than 4,000 heating degree-days and greater than 2,000 cooling degree-days

If you plan to upgrade any heating or cooling equipment, first implement your other ENERGY STAR upgrades. Earlier upgrades (such as lighting replacements or building construction improvements) may change the size requirements for your new heating or cooling system.

- Adjust chilled-water and hot-water temperatures based on indoor and outdoor temperature and humidity to let the cooling and heating systems operate most efficiently.
- Implement holiday period automatic setpoint adjustments.
- Monitor space temperatures to minimize overheating or over-cooling of spaces on a zone-by-zone basis.

An EMS can be used to control other functions in your building as well, such as lighting. It can be monitored and controlled from a console in a remote location, such as your home or your maintenance manager's home. EMS suppliers typically estimate that their EMS can cut the heating and cooling bills of a business with a central chiller and heating system by 10 to 50 percent (many estimates are clustered in the 20-percent range).

An EMS also can manage your electrical loads, prevent peak loads and optimize your electrical rate with your electric utility.

Improving Your System Efficiency

The remainder of this section offers suggestions on how to improve the efficiency of various types of HVAC systems. Because advice is offered on a variety of different systems, not every suggestion will apply to your facility. One piece of advice does apply uniformly to every business, however, regardless of the type of HVAC system: Maintain your HVAC system.

Regular maintenance is an often-overlooked key to saving on your HVAC costs and improving the performance of your system. Although some maintenance jobs may require calling in an outside technician, many can be

accomplished inexpensively using in-house staff. Because it also extends the life of your HVAC equipment, regular maintenance provides significant cost savings for minimal investment.

Most procedures will be included in your bi-annual comprehensive maintenance agreements with your licensed HVACR contractor. This type of system checkup will typically cost less than \$100 for a single system, with additional units included at a discount. Some examples of systems checks and standard maintenance procedures that you or your contractor should do on HVAC systems include:

- *Replacing your air filters regularly.* Accumulated dirt and dust make your fans work harder. Clean filters help system performance and help reduce allergens in your office. You can do this without a whole system checkup.
- *Cleaning the heat-transfer coils in heat pumps, air conditioners, and chillers.* Make sure that leaves and plants are not obstructing outdoor coils and have any bent coils straightened. In addition to saving energy, this measure will increase the capacity of your system.
- *Inspecting ducts and piping for leakage and missing or damaged insulation and making the indicated repairs.* Insulation is especially important in unconditioned spaces and leaky ductwork is one of the biggest contributors to cooling loss in buildings.
- *Making sure that furniture or other obstructions do not block air flow around radiators, convectors, and air intakes and diffusers.*
- *Identifying any areas in your facility that are unused but are being conditioned.* Consider turning off the HVAC to these areas or closing the vents.

- *Adjusting temperature and humidity setpoints seasonally.* Unless it is absolutely required for humidity control, consider turning off “reheat” from late spring to fall.
- *Having your fuel-fired boiler or furnace checked out at least annually, before the heating season starts.* Have the technician check the combustion efficiency and report the results along with any suggestions for improving boiler efficiency.
- *Repairing your old valves and steam traps.* A steam trap costs approximately \$50. If broken, it can waste hundreds of dollars each winter. One supplier estimated that an average of 20 percent of traps are broken nationwide. Broken steam traps not only waste money and energy, but they also cause extreme discomfort.

In addition to the maintenance changes suggested here, making operational changes and/or upgrading some aspects of your HVAC system may result in significant savings. These upgrades are more complex in scope and should be undertaken only after consultation with an engineering professional.

Things to look for in an HVACR contractor:

- The contractor complies with state and local codes and regulations and carries the proper business and workers’ compensation insurance.
- The contractor is prompt and courteous and provides fast, reliable service while attempting to perform service at your location.
- The contractor has the skill and knowledge not only to service your equipment, but also, if necessary, to design and install the right system for you.

When consulting an HVACR contractor:

- Ask the contractor for references. Current and former customers are an excellent source of information. Call these individuals and ask if they were (are) pleased with the contractor’s work. Make sure the references are recent or current customers so that you get timely information on the contractor’s business practices.
- Ask the contractor about his or her license. If a license is required in your area, ask for the license number.
- Always ask for a written price quote and information on service maintenance agreements (SMAs).
- Compare warranties and SMAs. The terms and coverage of warranties and SMAs can vary greatly. Compare them carefully. Are parts and labor included, or only parts, or only labor? Ask what type of repairs and parts are included. The cheapest SMA is not always the best buy.

Tips for Selecting Heating and Cooling Systems

- Proper sizing is critical to efficient performance.
- Check if utility rebates are available.
- When buying properly sized heating/cooling equipment, look for the ENERGY STAR label – your guarantee of savings. For more information, visit www.energystar.gov/ products or ask for “small business tech support” at 1-888 STAR YES.
- Call the ENERGY STAR hotline (1-888-STAR YES) to request all the materials you need to make you an “energy smart shopper.”



The Air Conditioning Contractors of America Web site is one of many with useful information about how to find a quality contractor. See page 9 for a list of others.

Success Stories

HVAC Equipment Pays Back in North Carolina

The cost of replacing HVAC equipment can be a burden for a small business, but a smart shopper can use the replacement as an opportunity to reduce operating costs by purchasing energy-efficient equipment.

Sud Associates, an engineering firm in Durham, NC, needed to replace HVAC equipment in its 2,200-sq-ft. office building. The 23-year-old system was a gas furnace with a continuously burning pilot light and an open flue. Cooling was provided by a condensing unit with a poor seasonal energy efficiency ratio (SEER) of 7.

The new heating system included a gas furnace with electronic ignition and a forced draft fan. Cooling equipment with a SEER of 12 was installed. This new system outperforms the old one, cutting both electric and gas usage while increasing comfort. The electronic ignition eliminates the continual gas use by the old pilot light, and the forced draft fan contains any heat lost through an open flue. The new gas furnace has cut gas usage by more than 20 percent in its first heating season. Elimination of the pilot light's energy use will add to the total savings. As the system is in its first year of installation at the time of this writing, actual cooling savings results are not available. However, electric savings due to the increased energy efficiency of the cooling equipment is predicted to be approximately 40 percent.

- Ask the contractor if he or she is a member of a national professional trade organization such as the Air Conditioning Contractors of America (ACCA). Such affiliations demonstrate that contractors have access to the latest technical information regarding HVAC systems, and make quality an integral part of their company operations.

This is Stage Five

Do you remember the five-stage approach from pages 31 and 32? If you plan to upgrade any heating or cooling equipment, be sure to do this after your other ENERGY STAR upgrades have been implemented because your earlier upgrades (such as lighting replacements or building construction improvements) may result in a change in size requirements for your new heating or cooling system. If you have a large or architecturally unique site, insist that the contractor complete a sizing worksheet or run a computer-

Technical Talk: Special Types of Heating and Cooling Systems

Systems That Simultaneously Heat and Cool. In reheat systems, air that is colder than required is supplied to a specific area and then reheated before it enters the room. In dual-duct or multizone systems, heated air is mixed with cooled air. Although these systems provide good temperature and humidity control, this simultaneous heating and cooling is inherently wasteful and should be minimized. If this is being done for humidity control, consider alternatives such as desiccants and heat pipes.

Single-Zone Chilled-Water Systems. Consider reducing the air volume and, during relatively dry seasons, raising the cooling supply temperature. Also consider conversion to a variable-air-volume (VAV) system.

Water-Side Systems. Consider downsizing oversized pumps and motors, installing variable-speed drives on pump motors, and converting single-loop configurations to a configuration with primary and secondary loops.

Water-Cooled Centrifugal Chillers. If your chiller predates 1990, it may be using R-11 or R-12 refrigerants. Manufacture of these has been banned due to the Clean Air Act Amendments of 1990, reducing their availability and making their prices skyrocket, so any upgrade should consider converting the chillers to utilize newer refrigerants. Consider replacing your chiller if it is more than 20 years old.

Boilers. Consider replacing an oversized, inefficient boiler with a smaller, more efficient boiler. Also consider upgrading an existing boiler with energy savings options such as a newer, more efficient burner (which will also reduce emissions), baffle inserts (to increase the efficiency of fire-tube boilers), combustion controls (to optimize efficiency each hour), warm-weather controls for hot-water boilers (to reduce the water temperature during milder weather), economizers (to preheat feedwater), and condensate return systems (for open-loop steam boiler systems). If you have multiple boilers, keep in mind that it is more cost effective to run one of them at full load than both at part load.

Large Central Systems. If you have a large central system and you find that one area of your facility operates for substantially more hours than the others, it may be cost effective to install a smaller, dedicated system in that area.

ized sizing analysis for your facility in its current state of repair. If you think the results inflate your needs, seek another quote.

Never buy oversized heating or cooling equipment on the theory that more capacity is better. This simply is not true. Grossly oversized cooling equipment will cycle too often and will be unable to sufficiently dehumidify your space, which creates a serious comfort issue. Such equipment will also cost more to run all year long. Heating equipment will be equally inefficient if oversized. This advice is difficult, perhaps the most difficult in this whole guide, to follow. Nobody wants to spend \$5,000 on a new air conditioner and find themselves sweating when cooling is sought. But both comfort and costs are at stake. Get the right size, not the right size plus one, and you'll be happy.

If your system was properly sized before making any ENERGY STAR improvements, your contractor may find that your system is now oversized and savings can potentially be realized by downsizing portions of it. If your system was undersized before you began your ENERGY STAR upgrades, you may find that your improvements have, in effect, balanced your loads and capacity by reducing your building loads and increasing your equipment capacity.

Hot New Technologies: Variable-Speed Drives, Heat Recovery, and Radiant Heating

Variable-Speed Drives (VSDs). If you have a larger system in your building, you may be able to take advantage of the savings available through installing VSDs on air blowers or even pumps. VSDs allow sophisticated control of how much air or water is provided by

heating and cooling equipment, which has a significant effect on how much energy is consumed.

Heat Recovery. Your business may require high levels of fresh air (for example, a laboratory with fume hoods). Installing heat recovery equipment will allow you to recapture some of the energy you have invested in heating or cooling that air and transfer it to the fresh air stream.

Radiant Heating. For areas where high ceilings, high infiltration, or low insulation levels make heating the air costly, natural gas-fired radiant heating (which heats occupants directly) is the answer. For warehouses, shop areas, and loading dock areas, installing radiant heaters can lead to big savings on your heating bills.

To find out more about these and other technologies, call the toll-free ENERGY STAR hotline at 1-888-STAR YES and ask for materials suited to your business. And remember, we're here to provide you with unbiased technical information for all your energy-efficiency upgrades.

Time for Another Repair?

Due to the high cost of large HVAC equipment, the energy savings alone may not justify replacement of equipment that is in good working order. If your equipment requires frequent repairs or is nearing the end of its life expectancy, however, it may be wise to consider replacing it from a preventive maintenance standpoint and an energy savings standpoint, as a scheduled replacement can generally be negotiated at a lower cost and with less inconvenience than the emergency replacement of a failed unit. Call your utility to find out if it offers rebates on high-efficiency equipment.

For more information on heating/ventilation/air-conditioning, and links to information on other energy efficiency/renewable resource technologies, as well as related industry trade associations, institutes, and organizations, visit the US Department of Energy's EREN (Energy Efficiency and Renewable Energy Network) Web site at <http://www.eren.doe.gov/consumerinfo/assn.html>.

Success Stories

A Successful Recipe in Renovation

Jan and Eddie Malone knew they had a challenge ahead of them when they purchased the Hotel Alice in 1999. Not only did the Malones have to become educated in the world of small business, but they had to contend with a complete renovation of the Hotel Alice. The Malones' vision was to turn the abandoned, three-story, 11,500-square foot historic building into a Bed and Breakfast, with a coffee shop/restaurant and antique shop on the first floor. Built in 1902, the building was also eligible for membership in the National Historic Registry, entitling the Malones to a 20-percent tax credit. The Malones also worked with a local architectural firm to review the existing building structure and make recommendations to keep the building's charm and historical features.



A view of the front of the Hotel Alice in Ellisville, MS.

In March 2000, the Malones learned about the Rebuild Mississippi team, which performed technical analyses on the building envelope, lighting, windows, plumbing, gas and electric systems, heating and cooling systems, roofing, and insulation and made numerous recommendations for improvements.

After reviewing all of the improvement recommendations, the Malones decided on a number of retrofits and renovations, which included the installation of a new HVAC system, energy-efficient windows, hot water heaters, and reflective roofing. The approximately \$350,000 in private investments needed to complete the retrofits has already yielded significant savings for the new hotel, which also serves as a meeting place for conferences, receptions and a variety of community activities. Utility bills for the business are proving to be 50 percent less than that of comparable enterprises in the area. In March 2001, Rebuild America honored the Hotel Alice Project with its Energy Excellence in Commercial Buildings Award.

To learn more about the Hotel Alice Project and track their progress, visit www.hotelalice.com.

Other Ideas for Energy Optimization

Ideas on energy optimizations and related profit enhancements are far more numerous than the ones presented in this guide. The possibilities are endless. In this section we will point out a few more specific ideas, but don't let us constrain you. Anywhere energy is used can be an opportunity for improvement.

Motors

The rules of thumb here are simple. First, buy high-efficiency motors whenever you replace old motors. Second, if you use a standard efficiency motor (less than 100 horsepower) 24 hours every day, replace it with its high-efficiency equivalent right away and your profits will increase in less than five years. Beyond that, your decision is mainly a factor of the motor-cost premium, hours of use, and your electricity cost, shown in the table in dollars per kilowatt-hour (\$/kWh).

Cooking Equipment

Don't preheat your cooking equipment. Don't preheat your electric or gas equipment for more than a few minutes. Although chefs are not likely to appreciate your telling them how to run their kitchens, it's worth a try.

Use the microwave or gas stove in place of electric resistance cooking when possible. Both cost less.

Buy the efficient version. Many fryers, broilers, soup kettles, and other equipment have optional controls and features that minimize their energy use. Often they are worth the additional cost, but we cannot offer a guarantee.



Improve kitchen ventilation. Turn off your makeup air unit whenever you are not cooking and especially at night. These units, together with the exhaust hoods, demand tremendous amounts of energy. You need to provide a safe and comfortable environment without odors and smoke, but turn both systems off when they are not needed.

When buying new equipment or appliances, look for the ENERGY STAR label, your guarantee of savings. For more information, visit www.energystar.gov/ products or ask for "small business tech support" at 1-888 STAR YES.

Should You Buy a High-Efficiency Motor?

Example: 25 Horsepower Motor
 \$208 Cost Premium for High-Efficiency Motor
 \$1,028 Total Cost for High-Efficiency Motor

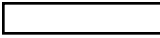
Motor Use Hours/Year	Annual Cost Savings at Electric Rate Shown (\$/kWh)			
	\$0.05	\$0.08	\$0.10	\$0.12
1,000	\$28	\$44	\$56	\$67
2,000	\$56	\$89	\$111	\$133
4,000	\$111	\$178	\$222	\$267
6,000	\$167	\$267	\$333	\$400
8,760	\$243	\$389	\$486	\$584

-  Always buy standard efficiency.
-  Buy high-efficiency motor upon burnout.
-  Buy high-efficiency motor immediately.

Lighting accounts for one third of the total power consumption in a typical vending machine.

Fuel Conversions

Electric resistance heating is typically the most expensive option when compared with natural gas, propane, and other fuels. If you already have gas onsite but still use electric-resistance heat for water heating, clothes drying, cooking, or other processes, ask your plumbing or general contractor to tell you what it will cost to convert your equipment. It could be a very good investment for equipment you use often or were going to replace anyway.

Vending Machines

Let's face it, vending machines are everywhere. They are in places such as office buildings, cafeterias, theatres, auto repair shops, congregation halls and various other locations. In other words, if you are thirsty and in need of a cold drink, you do not have to look very far to find a vending machine that meets your needs.

That's the good news, the bad news is that with so many vending machines operating 24 hours a day, energy waste is inevitable. In addition, this waste is undoubtedly causing stress on our natural resources and environment. A typical vending machine consumes about 3,000 kWh per year; four times that of a residential refrigerator!

But there's hope! Today manufacturers are rethinking the design of vending machines with more of a focus on environmental impacts. And now with the emergence of new and exciting "smart controls", the industry has the opportunity to reduce energy waste even further. Major energy saving advancements have been made in the following areas:

Efficient Lighting. Lighting accounts for one third of the total power consumption in a typical vending machine. Traditional T12 fluorescent

lamps can be successfully replaced with higher quality and more efficient T8 lamps. (Note, de-lamping is sometimes an option, but there are concerns of possible negative impacts on product sales)

Improved Refrigeration & Seals.

Improvements in compressor efficiencies and reductions in thermal leaks (through seal and insulation advancements) have led to machines that can minimize demand, usage and waste, while maintaining a superior product for customers.

"Smart Controls". Timers and new control advancements employing sensors are now being used to reduce energy waste without posing a risk to the products' ideal temperature and environment. These controls can "sense" when a product is needed and not waste energy consumed during long stand-by periods.

On a less technical note, the heating effect of the sun will cause a vending machine to consume more energy to cool its products. If your business's vending machines must be outside, locate them in a shaded area if possible.

Saving energy in vending machines can be achieved by both the purchase of new efficient models or by retrofitting existing models with "smart controls". Employing these tactics can save anywhere from 20 to 50 percent of the machines' energy consumption. Now that's a lot of soda!

Point-of-Use and Pressurized Water Coolers

Point-of-use (POU) and pressurized water coolers use a common refrigeration cycle to chill water for on-demand drinking. POU is the more common type of cooler typically using five

gallon bottles of water and dispensing the water through a tap using gravity to force out the water. Some of these POU coolers have heaters built in to provide on-demand hot water as well. Typical energy consumption of these devices may be 300 to 400 kWh/year with cooling only or 500 to 1,000 kWh/year with a heater. Pressurized water coolers use potable water from a building's domestic water supply providing on-demand chilled water usually by depressing a mechanical button or bar. Typical energy consumption for these is 300 to 400 kWh/year as well.

Water coolers are only needed during business hours. Your water cooler may be running even when no demand for drinking water exists. If you installed a simple plug-in timer set for business hours only, you could cut the operating cost for your water cooler in half. Energy consumption would drop from 300 to 400 kWh/year to 150 to 200 kWh/year as a result of this simple energy efficiency measure. If your business is only open during the workweek, your energy savings could be even greater as the timer shuts down your water cooler on the weekends. Currently ENERGY STAR is working on a performance standard for an ENERGY STAR labeled water cooler. The basis of the proposed label is simply adding a timer to the water coolers to qualify the manufacturer for an ENERGY STAR label. Your business can be ahead of the program by simply adding a timer today.

Many POU water coolers have an additional feature of providing instant hot water. This is an expensive option when you consider the energy consumption. Just cooling the water requires about 100 W of cooling power, but heating the water may require 500 W of heating power, five times as much energy! Consider whether or not your business really

needs this option. If it does, again, consider adding a timer to reduce energy consumption during idle periods. Also, if your business's POU water cooler has a hot water option, look for a small switch on the back of your unit. Many manufacturers include this switch to turn off the hot water feature. If so equipped, consider turning off the hot water supply if your business does not use the hot water feature.

Icemakers

Icemakers are found in most hotels, gas stations, restaurants, and convenience stores. Icemakers use a common refrigeration cycle to produce ice cubes for general use. Most icemakers use air-cooled condensers, like refrigerators, to reject heat. Some use potable water to cool the condenser making them more energy efficient, but costing the user added operating costs with water and sewage fees. Icemakers range in size from 100 to 1,500 lbs/24 hrs of ice generation.

If your business operates icemakers, you have a tremendous opportunity to save energy by selecting an energy-efficient model.

Using ENERGY STAR labeled water coolers can save your business as much as \$47 per unit!

Success Stories

Spain's Cookie Company's 4,500 sq.ft. office building was built in the early 1900s in the historic town of Galt, CA. The Spaan family has owned the firm since 1896. While protecting their history and architecture, Spaan's implemented a major lighting retrofit (inside and out), new HVAC controls, insulation, flooring, and windows. Annual savings of more than \$2,300 are projected, with the 30,570 kWh saved preventing 38,000 pounds of carbon dioxide emissions. Sharon Spaan says, "A very clear benefit is the example of what can be done to bring an old building up to date and make it efficient, while maintaining the historical presence."

A typical brewing element may consume 1,400 watts of energy, more than twice that of a residential refrigerator!

Energy consumption is rated in kWh/100 lbs of ice. Typical energy consumption ranges are from 4 to 13 kWh/100 lbs of ice. Remote condensers (located outdoors) are available on some icemakers. These types of icemakers are advantageous because the condenser's heat rejection is to the outdoors rather than inside your business where the air-conditioning equipment has to remove this heat. Remote condensing is usually available on large units only.

Annual energy consumption of a medium sized icemaker may be up to 5,000 kWh. Compare this to the energy consumption of a standard sized, residential refrigerator. Most standard sized refrigerators consume about 700 kWh/year or less. A single icemaker may consume as much energy as several standard refrigerators! If your business operates icemakers, you have a tremendous opportunity to save energy by selecting an energy-efficient model. Some of the most energy efficient models available in the marketplace may be up to 30 percent more efficient. Shopping for the most energy efficient one will help you save money and increase the profit in your business.

When purchasing an icemaker for your business, inquire about the energy consumption in kWh/100 lbs of ice and compare this energy level with several competitors. Compare air-cooled units with water cooled to determine which is best for your business. Water-cooled units use less energy per pound of ice, but may cost you more operating dollars given the added cost of water and sewage.

Commercial Coffee Machines

Commercial coffee machines are using more energy than you think.

Typical commercial coffee machines use energy both to maintain a supply of water at a certain temperature for instant brewing and to keep multiple pots of prepared coffee warm for employee consumption. The problem with this is that some coffee machines are designed to maintain a very hot water temperature at all times, even when not brewing coffee. The machine's energy-intensive brewing element turns on and off a few times an hour automatically to maintain that temperature. A typical brewing element may consume 1,400 watts of energy, more than twice that of a residential refrigerator! The only way to stop the brewing element from activating is to manually turn off the power switch (usually in the back of the machine) when it is not needed, i.e., overnight and weekends. The red indicator light switches that control the pot warmers do not control the brewing heating element. So even when all those red indicator lights are out and there is no coffee activity and you think everything is fine – you are still using energy!

To make sure that your coffee machine is not wasting energy, always check that the main on/off switch is in the off position when not in use. Manually performing this function is probably the simplest way to proceed, but for those of you that like gadgets, there are always timers that can be used to automate the process. One last thing to remember though, if you do turn off the coffee machine for the night or weekend, allow several minutes (consult your coffee machine operator manual) in the morning to let the machine warm up.

Success Stories

Vending Machines Prove to be Prosperous

The Moscow, Idaho School District was looking for a quick and easy way to begin to save energy and their facilities budget and the Avista Utility Corporation had just what they were looking for. Avista was offering VendingMiser units free of charge to communities in their service territory throughout northern Idaho and southern Washington. Avista's program would provide new, energy-saving technology, but allow their clients to take advantage of the payback costs.

The VendingMiser, which is manufactured by Bayview Technologies, Inc., uses a customized infrared sensor that limits the energy supplied to the machine when the surrounding area is unoccupied. The machines also are equipped with smart controls that "learn" the temperature of the room, increasing the power to the machine when necessary and ensuring the products remain at an optimal temperature. Taken together, these energy-saving measures reduce maintenance costs and extend the useful life of the vending machine. Each VendingMiser saves about 1,500 kWh of electricity a year, averaging approximately \$75 a year per machine.

In 2000, Avista installed 20 units in six of Moscow's schools. During the first six months of use, an additional 110 units were installed throughout the community. Currently, there are plans to install an additional 130-140 units. Once all of these machines are installed, Moscow, Idaho, will save about \$375,000 kWh or \$18,750 a year.



Each vending machine, that takes advantage of the VendingMiser (shown below) can save up to \$75 a year in energy costs.



If You Don't Do Anything Else... 12 Simple, Sure Energy Savers:

ENERGY STAR and Rebuild America advocate that optimal energy and dollar savings are the result of comprehensive efficiency upgrades. Comprehensive upgrades address all efficiency opportunities that offer an acceptable return-on-investment. The energy productivity of equipment can be enhanced just as the productivity of labor and capital can be managed for improvement.

This can sound complicated, and achieving optimal energy efficiency almost always requires professional technical assistance. However, if the requirements for comprehensive upgrades may stop a small business from taking action, there are twelve reliable, low-risk, high-return actions that are relatively simple.

Let's overview the comprehensive approach, first. In addition to the facility's "shell" (doors, windows, roofing, walls, floor, with their varying insulation/resistance values, reflectance, and thermal mass), the facility has "systems" (such as lighting, chillers, space heating/ventilation/air-conditioning, water heating). The facility's energy costs are also driven by equipment (computers, copiers, printers, fax machines, water heaters, water coolers, etc.) appliances (refrigerators, washers/dryers, dishwashers, stoves, vending machines, etc.). And, of course, the hours of operation, climate, type of business, and local utility rates, are also major factors in energy costs.

Sound complicated? Sure it does, but the highest savings require a strategic investment of time and money. That's why many of America's largest institutions and corporations have not yet implemented all the financially viable actions possible to save money with energy efficiency, even with on-site facility managers, and easy access to capital for improvements.

The above comprehensive list can be somewhat overwhelming for the smaller facility owner/operator, who probably lacks a professional facility manager "down the hall," or faces tough decisions on capital improvement and maintenance budgets. An applicable perspective here is that "perfection is the enemy of good." Meaning... if comprehensive efficiency upgrades are "too

much," then key, strategic upgrades are a lot better than doing nothing, even if targeted upgrades are not optimal and comprehensive.

To this end, Rebuild America and ENERGY STAR for Small Business suggest that "if you don't do anything else" at least implement all you can from this list of twelve simple energy savers.

- 1) Turn off lights and equipment when they are not in use. Seems obvious, but high utility costs often include paying for energy that is completely wasted. To automate this function, read on.
- 2) Buy ENERGY STAR labeled office equipment, and other products, when needed, and be sure the "stand-by mode" function is activated. This automatic "sleep mode" saves energy and money when the equipment is not in use, by reducing the "vampire" effect of "instant on" (always on) equipment, which is constantly drawing power.
- 3) Install "occupant sensors" in the proper locations to automatically turn off lighting when no one is present, and back on when they return. Sensors add convenience as well as save money. But, even good equipment can be installed wrong, so don't install the sensor behind a coat rack, door, or book case. It must be able to "see" the motion of occupant approaching an unlit area to turn on the light before, or as they enter. The savings come when people leave an area, and the sensor ensures that the lights are always, automatically turned off, until someone returns. Although, you, personally, never forget to turn off the lights, just think about all those other people wasting money.
- 4) Adjust lighting to your actual needs; use free "daylighting." This means turn off or dim your lights when daylight is adequate, or use automatic "daylight dimming" ballasts/controls to do this for you. To prevent computer screen glare, eyestrain, and headaches, use limited "task lighting" and do not "over-light" the area. Too much light can be as bad for visual quality as too little light - and it costs a lot more.
- 5) "Tune-up" your HVAC system with an annual maintenance contract. Even a new ENERGY STAR labeled HVAC (heating/ventilation/air-conditioning)

system - just like a new car - will decline in performance, without regular maintenance. A yearly "maintenance contract" will cost about \$100, but can save even more than it costs, and the contract automatically ensures that your HVAC contractor will provide "pre-season" tune-ups before each cooling and heating season.

- 6) Regularly change (or clean if reusable) the HVAC filters with your own "do-it-yourself" labor for a high "return-on-investment." During peak cooling or heating season, change or clean your filters every month; they cost about \$2-3 each. Dirty filters can cost up to \$5 a month extra, overwork the equipment, and result in dirtier indoor air. Consider purchasing "electrostatic" filters, which are washable, long lasting, and provide cleaner air. Clean or change filters more often if smokers, or pollution sources are present.
- 7) Install a programmable thermostat to automate your HVAC system. An "old-fashioned" thermostat turns the HVAC on and off based on temperature, not whether the building is occupied, or whether you benefit from the cooling/heating. This solid-state, electronic device can optimize HVAC operation "24/7" based on your needs. For example, instead of heating or cooling all night, so you can enter a comfortable building in the morning, this "smart thermostat" can turn on the HVAC one hour before you arrive, based on your daily/hourly needs. The cost can be \$100 to \$200, and it could cut your HVAC costs about 30 percent.
- 8) Replace incandescent light bulbs with compact fluorescent lamps (CFLs), wherever appropriate. CFLs cost about 75 percent less to operate, and last about 10 times longer. Enough said.
- 9) Install LED (light-emitting diode) exit signs. Your current fixture may accept a simple, "screw-in" lighting element to replace the small incandescent bulbs that burn out with frustrating frequency. This string of LEDs will cost about \$15 to \$20, will last decades, give brighter light, and end risky ladder climbing to replace bulbs. If your current exit sign will not accept the screw-in lighting element, a new LED exit sign fixture costs about \$100, and will still save about 90 percent over incandescent bulbs' operating costs.
- 10) Control direct sun through windows. During cooling season, block direct heat gain from the sun shining through glass on the East, and especially West sides of

the building. Depending on your situation, there are several options such as "solar screen," "solar film," awnings, and vines. Over time, trees can attractively shade the glass and building. Interior curtains or drapes can help, but it's best to prevent the Summer heat from getting past the glass and inside.

During heating season, with the sun low in the South, unobstructed Southern windows can contribute heat gain during the day, but should be covered at night.

- 11) Use fans. Comfort is a function of temperature, humidity, and air movement. Moving air can make a somewhat higher temperature and/or humidity feel comfortable. Fans can help delay or reduce the need for air-conditioning, and a temperature setting of only 3-5 degrees higher can feel as comfortable with fans. Each degree of higher temperature can save about 3 percent on cooling costs.

Ceiling fans can even be reversed in the Winter, and on low speed will pull warmer air down from the ceiling. When the temperature outside is more comfortable than inside, a "box fan" in the window, or "whole house" fan in the attic can push air out of the building and pull in comfortable outside air. In businesses, like restaurants, with high heat and humidity from cooking, fans can make a huge difference in employee and customer comfort, by giving a boost to air-conditioning. Fans can increase comfort and save money year round.

- 12) Plug the leaks with weatherstripping and caulking; another cheap "do-it-yourself" job. Caulking and weatherstripping let you manage your ventilation, which is the desirable, deliberately controlled exchange of stuffy inside air for fresher outdoor air. Most commercial buildings require 15-20 cubic feet per minute (cfm) ventilation per person for healthy indoor air. Exceptions and details can be found in "Building Air Quality" at www.epa.gov/iaq.

However, "air infiltration" in the uncontrolled "leaking" or exchange of inside air (which you paid to heat or cool) at a high rate through cracks around windows, doors, utility switches/outlets, and any other holes between the inside and outside. This can make heating or cooling a building very expensive, and still leave it uncomfortable, "drafty" or "clammy."



Money Isn't All You're Saving

ENERGY STAR® for small business

- Cut Energy Costs
- Free Tech Support
- Online B2B Directory
- Success Stories
- Awards
- Free Guidebook

"Putting Energy Into Profits is a dynamite new small business guidebook on saving energy — and boosting profits — from ENERGY STAR for small business. In helpful, step-by-step fashion, this portal to plumper profits proves once again that the best way for business to make money is often by saving it."

Daniel Kehrer
Editor-in-Chief
E-merging Business

★ *Start saving money and energy today.*

Visit www.epa.gov/smallbiz
or call 1-888-STAR YES

Choose small business on the phone menu
and ask for technical support. It's free!

ENERGY STAR for small business offers free technical support to help you cut your energy bills. ENERGY STAR provides unbiased information on what products and technologies really work, calculate savings estimates, and will walk you through planning your upgrade. We provide public recognition, including online success stories and national awards for excellent efforts.

SAVE MONEY

3

Supporting Material

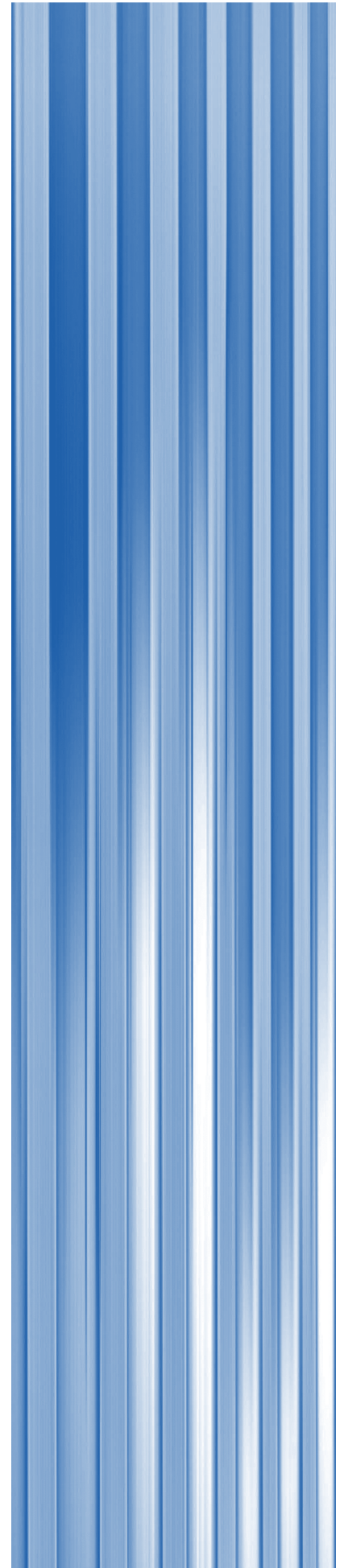

Supporting Material

Glossary

AHU: See Air Handling Unit.

Air Diffuser: A device used to distribute heated or cooled air to a space.

Air Handling Unit (AHU): A unit that usually contains filters, fans, and other components to heat, cool, humidify, or dehumidify interior air.

ASHRAE: American Society of Heating, Refrigerating, and Air-Conditioning Engineers.

Ballast: A device in fluorescent and high-intensity discharge (HID) lighting units that modifies incoming voltage and controls current.

Blending Valve: A valve that mixes hot and cold water to provide water at a lower temperature.

Boiler: A vessel designed to transfer heat produced by combustion or electric resistance to water. Boilers may provide hot water or steam, depending on design and settings.

British Thermal Unit (BTU): A unit of heat energy equal to the amount of heat required to raise the temperature of one pound of water by one degree Fahrenheit at sea level. This is roughly equivalent to the heat given off from burning a wooden match.

Building Envelope: The exterior surface of a building's construction—the walls, windows, doors, roof, and floor. Also called the building shell.

CFL: See Compact Fluorescent Lamp.

CFM: Cubic Feet per Minute, a measure of air flow.

Chiller: A device that generates a cold liquid that is circulated through an air-handling unit's cooling coil to cool the air supplied to the building.

Color-Rendering Index (CRI): A scale indicating the effect that a given light source has on the apparent color of objects viewed under it. It is expressed on a scale of 0 to 100, where 100 represents the color appearance of the object in daylight or under incandescent lights. Values of CRI above 80 indicate good color rendition.

Compact Fluorescent Lamp (CFL): Small fluorescent lamps frequently used as more efficient alternatives to incandescent lighting. They typically have 10 times the rated life and 3 to 4 times the efficacy of incandescent lamps.

Condensate Return System: A system of piping that returns the heated water condensing within steam piping to the boiler and thus saves energy.

Glossary

Condenser: Heat exchanger in a refrigeration system that rejects heat from the system.

Convector: A heating unit that circulates heated air by means of natural convection. Normally consists of a heating element within an enclosure, with an air inlet below and an air outlet opening above.

Cooling Tower: A device that dissipates the heat from water-cooled systems by spraying the water through streams of rapidly moving air.

CRI: See Color-Rendering Index.

Dampers: Single or multiple blades that are opened or closed in order to control the amount of air entering or leaving an air-conditioning system. Control can be either manual or automatic.

Deep-Cell Parabolic: A type of fluorescent fixture recommended for areas with computers. These fixtures direct light down, minimizing glare and reflections in computer monitors. See also louvers.

Degree-Day: A rough measure used to estimate the amount of heating required in a given area. A degree-day is defined as the difference between the mean daily temperature and 65 degrees Fahrenheit (F). This is based upon the assumption that no heating is required when the temperature is above 65° F, and that proportionately more heating is required the further the average temperature is from 65° F. Cooling degree-days may also be calculated to estimate cooling requirements.

Demand: The average rate of electrical usage used over a specified period of time (typically a 15-minute, 30-minute, or 1-hour period). Measured in kilowatts (kW).

Demand Charges: Fees charged by a utility company for electric demand. These charges are often highest during weekdays in summer.

Desiccant: A substance that is capable of extracting and retaining water from humid air.

Dual Duct: A type of heating, ventilating, and air-conditioning (HVAC) distribution system that involves simultaneous heating and cooling. Two supply ducts (a “hot deck” and a “cold deck”) serve each space, and the hot and cold air from them are mixed in the appropriate proportions before being supplied to the space.

Economizer: A mode of HVAC operation using outdoor air for cooling when outdoor temperature and humidity levels are suitable.

Efficacy: A measure of how efficiently a light source can produce light, expressed in lumens (of light output) per watt (of power input). For example, a 100-watt light source producing 9,000 lumens of light output has an efficacy of 90 lumens per watt.

Glossary

Efficiency: A measure of how much of a desired output is produced per unit of input; typically calculated as the amount of useful energy supplied divided by the energy consumed.

Electric Resistance Heat: Heat produced by a flow of electricity through high-resistance wire, tape, or film.

Electronic Ballast: A ballast for fluorescent lights that uses semiconductor components to increase the incoming electrical frequency from 60 hertz (Hz) to much higher levels (20,000 to 40,000 Hz), allowing lamps to operate with virtually no flicker and consume 12 to 25 percent less power than with standard ballasts.

Electronic Dimming Ballast: An electronic ballast that allows variable levels of light output.

EMS: See Energy Management System.

Energy Management System (EMS): A control system capable of monitoring environmental and system loads and adjusting HVAC operations accordingly in order to conserve energy while maintaining comfort. It may also be used for other control and monitoring, such as lighting and security.

Engine-Driven Chiller: A type of chiller that uses an engine fueled by natural gas, fuel oil, or diesel fuel instead of an electric motor.

Envelope (Building): The exterior surface of a building's construction—the walls, windows, doors, roof, and floor. Also called the building shell.

Feedwater: The water that is fed into a boiler to be heated.

Filter: A device that removes fine particles from the air stream in an air-handling system.

Footcandle (fc): A unit of measurement of the lighting levels on a surface, equal to one lumen per square foot.

Geothermal Heat Pump: See Ground Source Heat Pump.

GPM: Gallons Per Minute, a measure of flow rate for water or other liquids.

Gravity Dampers: Devices that close off a duct automatically by force of gravity when not kept open by fan-forced air flow.

Ground Source Heat Pump: Also called “Earth Coupled” and “Geothermal,” these heat pumps use underground coils to transfer heat from the ground to the inside of a building. Compared with conventional heat pumps, ground source heat pumps can have 40-percent higher efficiency but cost more to install. See also Water Source Heat Pump.

Halogen: A type of incandescent lamp with higher efficiency than standard incandescent lamps. Halogen produces a bright white light ideal for retail applications.

Glossary

Head: Pressure that a pump or fan has to work against for liquids to flow.

Heat Pipe: A passive heat exchanger that uses a refrigerant as the heat transfer medium.

Heat Pump: An electric device with both heating and cooling capabilities. It extracts heat from one medium at a lower temperature (the heat source) and transfers it to another medium at a higher temperature (the heat sink), thereby cooling the first and warming the second.

Heat-Transfer Coils: A component of heat pumps, air conditioners, and chillers that is used to transfer heat. They must be kept clean and clear of obstructions to operate efficiently.

HID: See High-Intensity Discharge.

High-Intensity Discharge (HID): A generic term used to describe mercury vapor, metal halide, and high-pressure sodium lamps and fixtures. Low-pressure sodium lamps, although not technically HID, are sometimes informally included in the use of this term.

High-Pressure Sodium (HPS): An efficient type of lighting often used for warehouse and exterior lighting. HPS fixtures emit a slightly yellow-orange light.

HPS: See High-Pressure Sodium.

Humidifier: A device that adds moisture to air.

HVAC: Heating, Ventilating, and Air Conditioning.

Hydronic: A ventilation system that uses heated or cooled water circulated by pumps throughout the building.

Illuminance: A measure of the amount of light incident on a surface or plane, expressed in lumens per square foot (footcandles) or lumens per square meter (lux). Commonly referred to as “light level.”

Internal Rate of Return (IRR): IRR is the interest rate that is equivalent to the present value of expected future cash flows after considering the initial cost of the project.

IRR: See Internal Rate of Return.

Kilowatt (kW): Unit of power (demand) equal to 1,000 watts.

Kilowatt-hour (kWh): A unit of electric energy equal to the energy consumed by a 1-kilowatt load operated for one hour.

LED: See Light-Emitting Diode.

Lens: A translucent or transparent piece of glass or plastic that shields the light source and redirects and scatters light passing through it.

Light-Emitting Diode (LED): An illumination technology used for exit signs that requires very little power and has a rated life greater than 80 years.

Glossary

Louver: Grid type of optical assembly used to control light distribution from a fixture. Can range from small-cell plastic louvers to the large-cell anodized aluminum louvers used in parabolic fluorescent fixtures. See also Deep-Cell Parabolic.

Low-Emissivity (low-E) Windows: A new window technology that lowers the amount of energy loss through windows by inhibiting the transmission of radiant heat while allowing plenty of light to pass through.

Low-Voltage Halogen: An incandescent lamp that produces bright white light at a higher efficiency than standard incandescent lamps. The high “sparkle” from low-voltage halogen lamps makes them well suited for retail spot lighting.

Lumen: A unit of measurement of light flow or luminous flux (the quantity of light emitted from a light source).

Luminaire: A complete lighting unit, consisting of one or more lamps, a housing, the optical components to distribute light, and electrical components (ballasts, starters, etc.) necessary to operate the lamps.

Megawatt: One million watts.

Metal Halide (MH): A type of lighting that combines high efficiency and an appealing bright white light. MH fixtures can be used for interior and exterior lighting. They are becoming the fixture of choice for retail areas with high ceilings.

MH: See Metal Halide.

Mixing Box: A component of an air-handling system in which air streams from two different sources are combined to form a uniform air stream.

Modified Bin Method: A method for calculating the required heating or cooling for a building based on determining how much energy the system would use if outdoor temperatures were within a certain temperature interval (or “bin”) and then multiplying that energy use by the amount of time that the temperature interval typically occurs at the site. Bin weather data for a variety of sites are tabulated by both the U.S. Air Force and ASHRAE. The energy use for all of the applicable temperature bins is summed to determine the total estimated energy use by the system.

Multizone: A type of HVAC distribution system that involves simultaneous heating and cooling. Hot and cold air are supplied at the multizone unit and mixed in appropriate proportions to provide the supply-air temperatures needed in each zone.

Occupancy Sensor: A device that detects the presence (or absence) of occupants in an area and causes equipment to be adjusted accordingly.

Payback, Simple: A traditional measure of the economic viability of a project, generally defined as the length of time it takes for savings from an investment to equal the cost. Although frequently used because of its ease of calculation,

Glossary

payback frequently does not give an accurate representation of the total lifecycle value of an investment.

Photocell: A light-sensing device used to control light fixtures and dimmers in response to detected levels.

Prismatic Plastic Lens: The cover installed on many standard fluorescent fixtures. These lenses are often bright light sources that create uncomfortable reflections in computer monitors.

Programmable Thermostat: A control device for HVAC systems that allows the user to program in various temperature and fan settings for various times.

Radiant Heaters: A technology that heats building occupants by radiating heat from an electric or combustion source. Because radiant heaters use radiation instead of convection to transfer heat, they are very efficient in areas where high ceilings or high infiltration make heating the air costly.

Refrigerant: A substance used to provide cooling, either as the working substance of a refrigerator or by the direct absorption of heat.

Reheat: A type of HVAC air distribution system in which air maintains comfort in a building by cooling the air to a low temperature (typically 55 degrees F) at the air handler and then reheats it near its point of use. This system provides good temperature and humidity control but wastes considerable energy.

Retrofit: Upgrading a fixture, room, or building by installing new parts of equipment.

R-Value: A measure of thermal resistance or the ability of a material or group of materials to retard heat flow.

Setback: Setting a thermostat to a lower temperature when the building is unoccupied to reduce heating energy consumption. This may also refer to setting the thermostat to higher temperatures (“setup”) during unoccupied periods in the cooling season and operating the fan in “auto” mode (rather than constant operation) during unoccupied periods.

Shading Coefficient: The amount of the sun’s heat transmitted through a given window compared with that of a standard 1/8-inch-thick single pane of glass under the same conditions.

Static Pressure: The condition that exists when an equal amount of air is being supplied to and removed from a space.

Steam Trap: A valve that allows condensed water to flow out of a steam supply line without allowing any of the steam to escape.

Supply-Air Diffuser: A device used to evenly distribute supply air to a space.

Tandem Wiring: A wiring option in which a ballast is shared by two or more fixtures. This option reduces labor, material, and energy costs.

Glossary

Thermostat: A device typically contained in heating, cooling, and refrigeration systems which automatically responds to temperature changes and activates switches controlling the equipment.

Ton: A unit of measure of refrigeration or air-conditioning capacity; by definition equal to 12,000 BTU/hour. This is a holdover from when refrigeration was primarily used to make ice (for people to use in home iceboxes). A “three ton” refrigeration unit could make three tons of ice from 32 degrees F water in a day.

T-12 Lamp: Industry standard nomenclature for a fluorescent lamp which is twelve 1/8 of an inch (1 1/2 inch) in diameter. Other standard lamp sizes include T-8 (1 inch), T-10 (1 1/4 inch), and T-5 (5/8 inch).

Variable Air Volume (VAV): A type of air-handling system that maintains comfort in a building by supplying varying quantities of air throughout the building based upon the needs of individual spaces.

Variable-Speed Drive (VSD): A device that is used to adjust the speed of an AC motor to match load requirements. Since motors require less power to operate at slower speeds, this provides energy savings.

VAV: See Variable Air Volume.

VSD: See Variable-Speed Drive.

Waste Heat Recovery: Recovering heat that is discharged as a byproduct of one process to provide heat required by a second process. For example, recovering heat going up the flue of a boiler to be used to preheat boiler feedwater.

Water-Side Systems: HVAC systems in which water is used to provide heating or cooling, including pumps, chillers, boilers, and other equipment.

Water Source Heat Pump: Heat pumps that use wells or heat exchangers to transfer heat from water to the inside of a building. Although most of these units use ground water, a small number of installations use surface water, such as ponds or streams. Compared with conventional heat pumps, water source heat pumps can have 50-percent higher efficiency, but cost more to install. See also Ground Source Heat Pump.

Watt (W): A unit of electric power. It defines the rate at which electric energy is consumed.

Xeriscaping: (From the Greek *xer*, which means dry.) A technique of utilizing native, hardy, low-maintenance plants for landscaping. Xeriscaping reduces water, pesticide, and fertilizer requirements.

Zone: A distinct area to which heating or air conditioning is supplied.

FREE

Publications and Programs



Request any of the following free materials by calling 1-888-STAR YES. And remember, ENERGY STAR for small business partners may request information related to any program. ENERGY STAR updates the material in this fast-changing marketplace regularly. Call for the latest information.

Information on the ENERGY STAR Family of Programs

- ENERGY STAR for small business: for businesses of 100,000 square feet or less.
- ENERGY STAR for business: for businesses greater than 100,000 square feet.
- ENERGY STAR Office Equipment: for companies that sell computers, copiers, and other office equipment.
- ENERGY STAR Homes: for home builders and home buyers.
- ENERGY STAR Heating and Cooling: for residential heating and cooling system manufacturers.

The following types of information are available for all of the above programs

- Information packs: general program information
- Technologies: reports on high-efficiency equipment (available for the Buildings, Heating and Cooling, and Office Equipment programs)
- Case studies
- Analytical software tools
- Communications and promotional materials



Average Energy Use and Costs Throughout the United States

Calculate Your Total Energy Intensity Here
 (or visit the online calculator at www.epa.gov/smallbiz/calculate.html)

1. Collect one year of bills for each energy type and multiply by these conversion factors:

- Annual kWh of electricity x 3.4 _____
- Annual therms or ccf of natural gas x 100 _____
- Annual gallons of #2 fuel oil (diesel fuel) x 140 _____
- Annual gallons of #6 fuel oil x 150 _____
- Annual Mlb. of purchased steam x 1040 _____
- Annual gallons of propane x 91 or _____
- Annual pounds of propane x 22 _____

Total (A) _____ kBtu/year

2. Write down the size of your facility, in square feet (B) _____ square feet

3. Calculate your total energy intensity by dividing (A) by (B), and write this number on line (C). (C) _____ kBtu/sq.ft./year

4. Find the climate map with your location shaded. Then find the average energy use and costs for similar buildings on the adjacent table and compare them with your energy use from line (C).
 How do you rate?

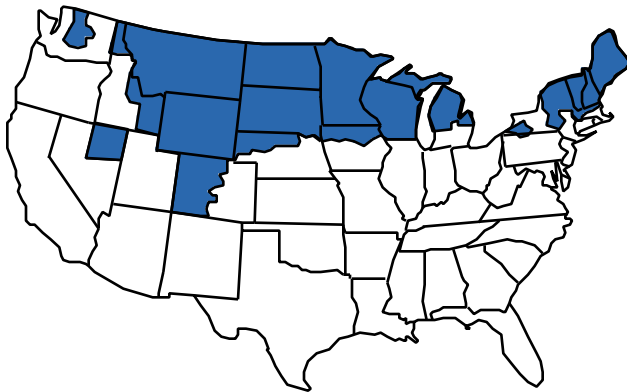

U.S. Climate Zone 1		
Building Type	Annual Energy Use (kBtu/sq.ft.)	Annual Energy Cost (\$/sq.ft.)
Education	77	\$0.93
Food service	155	\$2.32
Health care (inpatient)	270	\$2.65
Health care (outpatient)	118	\$1.33
Lodging	133	\$1.42
Office	93	\$1.46
Public assembly	66	\$0.95
Religious worship	53	\$0.48
Restaurant	250	\$3.99
Retail	77	\$0.99
Warehouse (non-refrig.)	59	\$1.09
Warehouse (refrigerated)	65	\$1.45

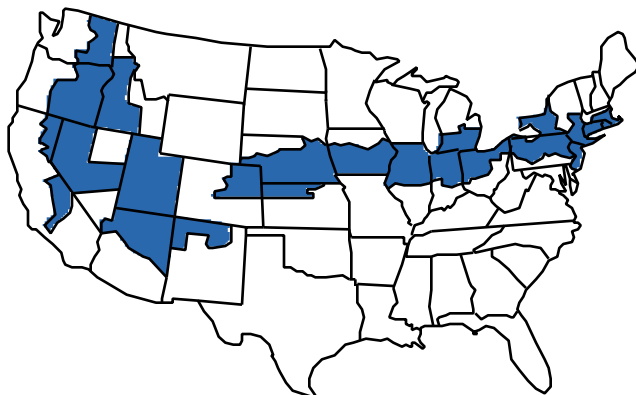

U.S. Climate Zone 2		
Building Type	Annual Energy Use (kBtu/sq.ft.)	Annual Energy Cost (\$/sq.ft.)
Education	88	\$1.08
Food service	169	\$2.19
Health care (inpatient)	269	\$2.63
Health care (outpatient)	84	\$1.25
Lodging	92	\$1.54
Office	95	\$1.49
Public assembly	77	\$1.26
Religious worship	61	\$0.68
Restaurant	250	\$3.99
Retail	87	\$1.21
Warehouse (non-refrig.)	64	\$0.80
Warehouse (refrigerated)	65	\$1.45

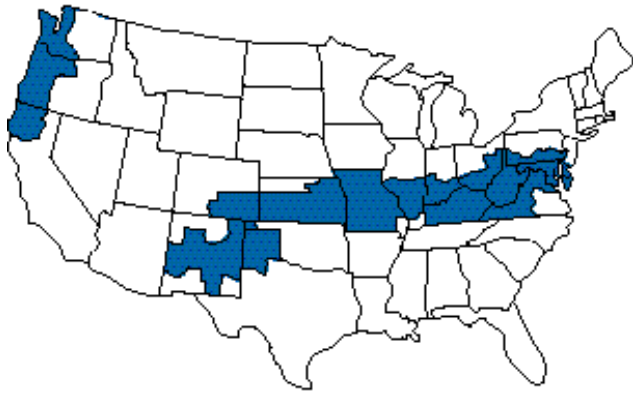

U.S. Climate Zone 3		
Building Type	Annual Energy Use (kBtu/sq.ft.)	Annual Energy Cost (\$/sq.ft.)
Education	69	\$0.99
Food service	213	\$2.73
Health care (inpatient)	204	\$2.35
Health care (outpatient)	80	\$1.30
Lodging	96	\$1.86
Office	80	\$1.59
Public assembly	66	\$1.19
Religious worship	35	\$0.45
Restaurant	226	\$4.16
Retail	64	\$1.25
Warehouse (non-refrig.)	51	\$0.93
Warehouse (refrigerated)	65	\$1.47

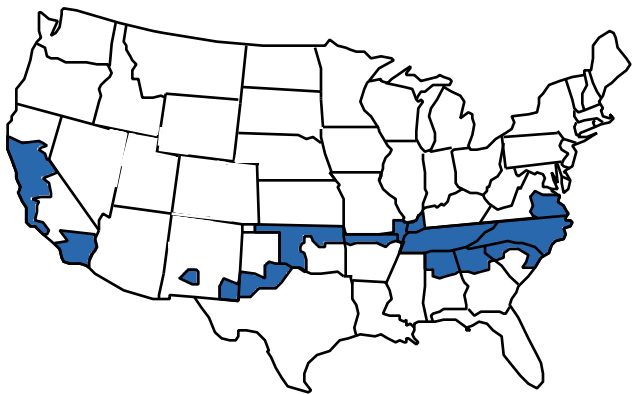

U.S. Climate Zone 4		
Building Type	Annual Energy Use (kBtu/sq.ft.)	Annual Energy Cost (\$/sq.ft.)
Education	66	\$1.17
Food service	232	\$2.49
Health care (inpatient)	227	\$2.89
Health care (outpatient)	74	\$1.36
Lodging	115	\$1.65
Office	72	\$1.54
Public assembly	72	\$1.32
Religious worship	38	\$0.59
Restaurant	134	\$3.03
Retail	68	\$1.36
Warehouse (non-refrig.)	36	\$0.83
Warehouse (refrigerated)	96	\$2.02

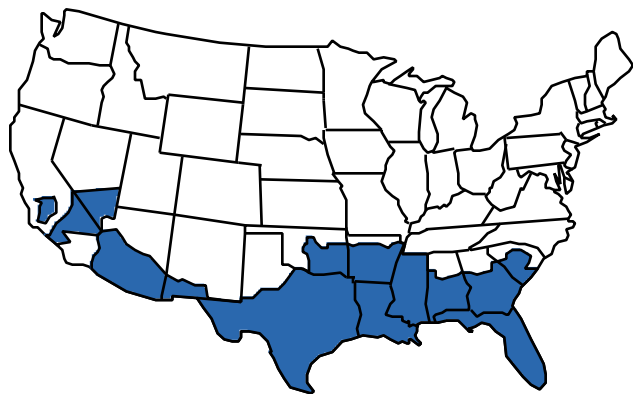

U.S. Climate Zone 5		
Building Type	Annual Energy Use (kBtu/sq.ft.)	Annual Energy Cost (\$/sq.ft.)
Education	56	\$1.11
Food service	195	\$2.89
Health care (inpatient)	202	\$2.76
Health care (outpatient)	100	\$1.67
Lodging	102	\$1.62
Office	68	\$1.55
Public assembly	54	\$1.17
Religious worship	34	\$0.59
Restaurant	161	\$3.20
Retail	56	\$1.26
Warehouse (non-refrig.)	33	\$0.77
Warehouse (refrigerated)	55	\$1.17

Index

A

Aerators, faucet, 59
 Air-conditioning, 10, 51, 66. *See also* Heating, ventilating, and air-conditioning (HVAC) systems
 Air flow blockage, HVAC systems, 74
 Air leakage, reduction of, 32, 65, 68–69, 74
 American Society of Heating, Refrigerating, and Air-Conditioning Engineers (ASHRAE), 67, 91
 American Solar Energy Society, 9, 59
 Attics, forced ventilation in, 68
 Attic vents, 68
 Awnings, 20, 31–32, 67

B

Background ambient lighting, 34
 Ballasts, electronic, 37, 40, 42–43, 47, 89
 Bids, 15–17
 Bill analysis, 21, 49
 Binding arbitration, 17
 Blending valve, 57–58
 Blinds, Venetian, 67
 Blowers, 79
 Boilers, 75, 76
 Building construction, 8, 65–69
 Building envelope upgrades, 65–69
 Building tune-up, 7, 31–32, 49

C

Carbon dioxide (CO₂), 23–24
 Ceiling fans, 10
 Centerplex, Seattle-based, 72
 Chilled-water systems, single-zone, 76
 Chillers, 74, 89
 Chlorofluorocarbons (CFCs), 64
 Color-rendering index (CRI), 35, 87
 Color rendition, 34–35, 37, 41
 Compact fluorescents, 7, 9, 28, 31, 35–36, 39–41, 89
 Computers, 7, 20, 33–35, 45, 51–53
 Consultants, 3, 8–9
 Contractors, 3, 8–9, 15–17
 Controls contractors, 8

Cooking equipment, 79
 Cooling, 8, 10–11, 13–14, 22, 31–32, 63, 65–66, 68, 71–77. *See also* Heating, ventilating, and air-conditioning (HVAC) systems
 Cooling coils, refrigerator, 63
 Copiers, 51–53, 55
 Copying, double-sided, 55
 Curtains, 67
 Customer comfort, 10, 27, 37

D

Daylighting, 34
 Defrost cycles, 63–64
 Degree-days, 73, 90
 Demand charges, 11, 90
 Desiccants, 76, 90
 Display cases, refrigerated, 64
 Distribution system, HVAC, 32
 Doors, air leakages from, 68–69
 Door seals, refrigerator, 63
 Draperies, 67

E

Economizers, 72, 90
 Electrical contractors, 8
 Electric bill, 11–12, 21, 23–24, 49
 Electric energy intensity, 11–14
 Electric resistance cooking, 80
 Electric resistance heating, 79, 91
 Electronic ballasts, 37, 40, 42–43, 47, 91
 E-mail, 20, 56
 Employee productivity, 27, 37
 Energy audits, 3, 8–9, 16, 49
 Energy efficiency, learning about, iii, 7–9
 Energy Efficiency Ratio (EER), 64
 EnergyGuide-labeled appliances, 58, 64
 Energy inflation, protection from, 27–28
 Energy Management Systems (EMSs), 8, 22, 73–74, 91
 Energy saver lamps, 39, 43
 Energy Services Company (ESCO), 3, 6, 8, 16

Index

ENERGY STAR “Finance Directory”, 5
ENERGY STAR five-stage approach,
31–32, 47, 76
ENERGY STAR program results, 23
ENERGY STAR-labeled equipment, iii,
31–32, 51–53
ENERGY STAR for small business
program, iv, 23–24, 28
ENERGY STAR for small business Web site,
iv, v, 5, 9, 20, 51
ENERGY STAR Web site, 15, 84
Energy use, measurement of, 11–14
Entrances, 69
Envelope (building) upgrades,
65–69
EPA Stratospheric Ozone Hotline, 64
Evaporator fans, high-efficiency, 64
Exit signs, light-emitting diode (LED),
7, 31, 39–40, 42
Exterior lighting, 44–45

F

Fan cycling, 71
Fans, 10, 32, 64
Faucet aerators, 59
Faucets, automatic controls, 60
Fax machines, 51, 53
Fiber products, recycling of, 56
Filters, 8, 31, 49, 74
Finance Directory (ENERGY STAR), 5
Financial analysis, 21–22, 27–29
Floating head pressure system, 64
Flood lights, 44
Fluorescent lamps, 34–37, 41–43.
See also specific type
Freezers, 10, 63–64
Fuel conversions, 80
Furnaces, 31, 75

G

Gair, Kenneth, iv, 47
Gas Manufacturers Association
(GMA), 61
Gas stoves, 79
Global warming, 23–24, 64

Gray water, 60–61
Green Lights program results, 23
Green pricing, 23–24

H

Halogen lamps, 35–36, 39, 41, 91
Heating, 8–9, 11, 13–14, 22, 31–32, 49,
57, 59, 65–68, 71–77. *See also* Heating,
ventilating, and air-conditioning
(HVAC) systems
Heating, ventilating, and air-
conditioning (HVAC) contractors, 3, 9
Heating, ventilating, and air-
conditioning (HVAC) systems, 3,
9, 32, 71–77, 92
Heat pipes, 77, 92
Heat pumps, 74, 92
Heat-pump thermostats, 72
Heat pump water heaters, 58, 61
Heat recovery, 58, 64, 75
Heat-transfer coils, 77, 92
High-intensity discharge (HID) lamps,
35–36, 44–45, 92
High-pressure sodium (HPS) lamps,
36, 39, 44–45, 47, 90
Home offices, 24
Hot water temperatures, 57–58
Humidistats, 64
Humidity control, 71, 74, 76

I

Ice makers, 10, 81–82
Illuminating Engineering Society (IES),
33
Incandescents, 7, 28, 35–36, 39–42, 47
Infiltration, reduction of, 68–69
Installation support, 8
Insulation, 32, 57–58, 67–69
Internal Rate of Return (IRR), 28–29, 92

K

Kaplan, Steve, 10
Kilowatt-hour (kWh), 23–24, 92
Kitchen ventilation, 79

Index

L

Landlords, 19–20
 Landscaping, 31, 60, 67
 Large central systems, 76
 Leasing arrangements, 19–20
 Lens, prismatic plastic, 34, 92
 Light-emitting diode (LED) exit signs, 7, 31, 39–40, 42, 92
 Light fixtures, 35–36, 39–43, 45. *See also specific type*
 Lighting, 7, 31–37, 39–47
 Lighting assessment, high-speed do-it-yourself, 39–40, 46
 Lighting contractors, 8
 Lighting controls, 45–47
 Lighting efficiency, 35–37
 Lighting upgrades, 10, 31, 34–35, 37, 39–47
 Light levels, 33–35, 37, 45
 Light meters, 21–22, 34
 Light quality, 34–35
 Loading docks, 68–69
 Load reduction, 31–32
 Loans, 5–6
 Local area networks (LANs), 56
 Louvers, parabolic, 34–35, 93
 Low-emissivity (low-E) windows, 66, 93
 Low-pressure sodium lamps, 35–36, 45

M

Maintenance, 10, 31–32, 58, 60, 74–75
 Marketing, as ENERGY STAR Partner, 20, 28, 37
 Mechanical contractors, 8
 Mercury vapor lamps, 36, 40, 44
 Metal halide (MH) lamps, 36, 39–40, 43–44, 47, 93
 Metering, 21–22, 34
 Microwaves, 79
 Monitors, computer, 34, 52–53
 Motion sensors, 46
 Motors, 79

N

National Association of Energy Services Companies (NAESCO), 8
 Nitrogen oxides (NO_x), 23–24

O

Occupancy sensors, 7, 20, 45, 93
 Office equipment, 7, 20, 31–32, 51–53, 55. *See also Computers, Copiers, Fax machines, Monitors, and Printers*
 Operations and maintenance contractors, 8
 Operations and maintenance savings, 27
 Outside security lamps, 44–45

P

Paper, 7, 55–56
 Paper conservation, 55–56
 Paper recycling, 55–56
 Parabolic louvers, 34
 Payback, simple, 28–29, 46, 93
 Performance contracting, 6
 Photocells, 45, 60
 Plant, HVAC, 32
 Pollution prevention, 23–24
 Pool, Jonathan, 72
 Post-consumer content, of paper, 55
 Printers, 51–53
 Prioritizing, 31–32
 Prismatic plastic lens, 34, 94
 Profits, 27–29
 Programmable thermostats, 20, 22, 72, 94
 Proposals, request for, 15–17
 Pumps, 32, 57–58, 61, 72, 74

R

Radiant barriers, roof, 68
 Radiant heating, 69, 77, 94
 Recycled paper, 55–56
 Recycling, paper, 55–56
 Reference check, of contractors, 17
 Reflective roof coverings, 68

Index

Reflectors, 10, 41–43, 45
Refrigerated display cases, 64
Refrigeration, 8, 10, 13–14, 63–64
Reheat systems, 76, 94
Remodeling, 69
Rent costs, reducing energy and, 19–20
Request for proposal (RFP), 15–17
Roof coverings, reflective, 68
Roof insulation, 67–68
Roof spray system, 68
Roof upgrades, 65–68
R-Values, 66–69, 94

S

Savings reinvestment, 6
Savings verification, 21–22
Screen savers, 52–53
Seals, 59–60, 63
Seasonal energy efficiency ratio (SEER), 76
Sensors, 7, 20, 34, 45, 47
Setback, of thermostats, 71–74, 94
Shades, 20, 67
Showerheads, 20, 59
Simple payback, 28–29, 46, 93
Single-zone chilled-water systems, 76
Sligo Adventist School, iv, 47
Small Business Administration loans, 5–6
Sodium lamps, 35–36, 39–40, 44–45, 47
Solar water heaters, 20, 59
Spot metering, 21–22
Steam traps, 75, 94
Stoves, 79
Subway franchise, 10
Sud Associates, 76
Sulfur dioxide (SO₂), 23–24
Sunlight simulation, 35
Supplier loans, 6

T

T-8 lamps, 35, 40, 42–43, 47
Task lighting, 34
Tax implications, 6
Temperature settings, 63, 71–75

Tenants, 19–20
Thermostats, 8, 20, 22, 49, 57–58, 71–75, 93
Thermostat setback, 71–74
Time investment, 3
Timers, 22, 49, 57
Toilets, 20, 60
Total recycled content, of paper, 55
Tubular fluorescent lamps, 35–36, 39, 41

U

Utility bill analysis, 21, 49
Utility loans, 6

V

Variable-air-volume (VAV) system, 76, 95
Variable-speed drives (VSDs), 77, 95
Venetian blinds, 67
Ventilating. *See* Heating, ventilating, and air-conditioning (HVAC) systems
Ventilation, 13–14, 68
Vestibules, 69

W

Wallboard coverings, 69
Walls, 67–69
Washing machines, 60
Waste heat recovery, 58, 95. *See also* Heat recovery
Waste water, reusing, 60–61
Water-cooled centrifugal chillers, 76
Water heaters, 8, 10, 57–61, 64
Water-side systems, 76
Water temperature, 57–58
Water use, 8, 59–61
Web sites, iv, v, 3, 5, 6, 8, 9, 15, 20, 24, 51, 59, 61
Whole-building energy optimization and management systems, 73–74
Window films, 31–32, 66–67
Windows, 31–32, 65–68

X

Xeriscaping, 60, 95

Energy-Efficiency Quicklist

This guide recommends a lot of different energy upgrades. Where should you start? First walk through your business with this Quicklist in hand and use it to identify money-saving opportunities. Then post the Quicklist on your wall and check off items as you perform upgrades to keep track of your progress.

Lighting



- Replace incandescent light bulbs with compact fluorescent lamps.
- Convert exterior lighting to high-pressure sodium or metal halide lighting.
- Upgrade fluorescent fixtures with T-8 fluorescent lamps and electronic ballasts.
- Remove or disconnect unnecessary lights.
- Convert exit signs to LED.
- Lower light levels where appropriate, such as around computer monitors.
- Install occupancy sensors in areas such as bathrooms that are frequently unoccupied.
- Install timers or photocells on outside lights.

Water Use and Water Heating

- Install a water heater insulating blanket and wrap the first three to six feet of hot water supply pipe with pipe insulation.
- Install faucet aerators and efficient showerheads.
- Select native or other low-water plants for landscaping.
- Find and fix leaks.

Refrigeration

- Repair doors and seals so they close tightly.
- Make sure fans and equipment are not obstructed.
- Combine refrigerated goods and disconnect unneeded refrigerators.

Building

- Install weather stripping, caulking, or seals on openings that create drafts.
- Add or repair insulation to create a continuous blanket around building.

Heating and Cooling Systems

- Clean and replace filters regularly.
- Set back your heating, ventilating, and air-conditioning (HVAC) systems when the building is unoccupied. This includes setting the fans to “auto” rather than “on.”
- Repair leaks in system components such as pipes, steam traps, and couplings.
- Make sure radiators, convectors, air intakes, and air diffusers are not obstructed so that air can flow freely.
- Reduce your water heater settings to the minimum required temperature.

ENERGY STAR for Small Business Building Shopping List

Buying or leasing a building with these preferred technologies can lower your operating costs and may give you a competitive advantage. Use this list when walking through a prospective building to see if the building will help or hurt your profit. Call 1-888-STAR YES if you have any questions.

		Yes	No			Yes	No
Lighting				Heating			
General	T-8 Fluorescent Lamps	___	___	High-Efficiency Gas Furnace	___	___	
	Compact Fluorescent Lamps	___	___	Pulse Combustion Boiler	___	___	
	Occupancy Sensors	___	___	High-Efficiency Heat Pump	___	___	
	LED Exit Signs	___	___	Insulated Pipes/Ducts	___	___	
	Low-Glare Daylight	___	___	Ducts All Inside Building Envelope	___	___	
Warehouse	High-Pressure Sodium (HPS) or Metal Halide (MH) Lighting	___	___	Electronic Ignition (No Pilot Light)	___	___	
Retail	Halogen	___	___	Cooling			
Office	Light Level Below 75 Foot-candles	___	___	Newer High-Efficiency Cooling Units	___	___	
	Deep-Cell Parabolic Fixtures	___	___	Economizers/"Free Cooling"	___	___	
Exterior	HPS or MH	___	___	Coils Clean and Free of Moisture	___	___	
	Photocells or Timers	___	___				
Hot Water				Other			
	Insulated Pipes	___	___	Locker Room	___	___	
	Water Heater Insulating Blanket	___	___	Access to Bike Path	___	___	
	Faucet Aerators	___	___	Subway or Bus Nearby	___	___	
	Efficient Showerheads	___	___	Xeriscaping	___	___	
	Solar Hot Water	___	___	Lease That Rewards Efficiency	___	___	
Building				Notes			
	Low-E Windows	___	___	_____			
	Awnings To Block Summer Sun	___	___	_____			
	Window Film	___	___	_____			
	Roof Insulation	___	inches	_____			
	Wall Insulation	___	inches	_____			
	Tight-Closing Doors/Windows	___	___	_____			
	Reflective Roof	___	___	_____			
	Operable Windows	___	___	_____			
Heating and Cooling Distribution				_____			
	Energy Management System Programmable Thermostats	___	___	_____			
	Variable-Speed Drives	___	___	_____			
	Energy-Efficient Motors	___	___	_____			

