

FIRE, ROCK, AND WATER

VOLCANOES!

LESSON 4

fig. 1

Mount St. Helens



© DAVID MUECH

Mount St. Helens 2 years before its cataclysmic eruption. When the volcano exploded on May 18, 1980, huge volumes of snow and ice quickly melted and contributed to devastating floods and mudflows.

As hot volcanic debris melted snow and glacier ice on the upper slopes of Mount St. Helens, **mudflows**—fast-moving mixtures of volcanic debris and water—developed within minutes of the beginning of the May 18 eruption. By 10:10 a.m. Pacific Daylight Time, a mudflow had traveled 43 kilometers (27 miles) downstream in the South Fork Toutle River valley. And before the day ended, nearly all the streams that had their sources on Mount St. Helens were affected by mudflows.

Fortunately, the major mudflow took hours to reach populated areas, giving people time to evacuate. As a result, only a few deaths were attributable to mudflows. Volcanic mudflows are also called **lahars**, a term borrowed from Indonesia, where mudflows are a major volcanic hazard.

Mudflows' Destructive Force

The largest and most destructive mudflow came down the valley of the North Fork of the Toutle River. It originated from the hot debris from the avalanche, lateral blast, and ash falls that had been deposited in the upper part of the river valley during the first few minutes of the eruption. By afternoon, water from melting snow and glacial ice, and from within the debris itself began to flow.

The mudflow steamed with hot volcanic materials (**pyroclastic debris**). Thick, like freshly mixed cement, the mudflow enveloped almost anything that it picked up along its path. Eyewitnesses reported seeing everything from ice chunks to a fully loaded logging truck in the flowing mixture. As debris, mud, and fallen trees choked the Toutle River, the river overflowed its banks and flooded, cresting at 6.4 meters (21 feet) above its normal stage.

Snow and Ice Compound Dangers

Mudflows are particular hazards at snow-capped volcanoes such as Mount St. Helens. Even small eruptions of hot volcanic material can very quickly melt large volumes of snow and ice. The resulting surge of water erodes and mixes with volcanic rock to become mudflows. For example, the 1985 eruption of Nevada del Ruiz in Colombia was a very small eruption—ejecting only about 3 percent as much magma as Mount St. Helens—yet it generated high-volume mudflows because of the presence of snow and glacial ice on the volcano. The mudflows that swept down from Nevada del Ruiz buried the town of Armero, killing more than 23,000 people. Nevada del Ruiz, like Mount St. Helens, has snow and ice year round at its highest elevations.

The Risk of Mudflows Continues

Even without a major eruption, mudflows and floods remain potential hazards of Mount St. Helens. As a result of the May 18, 1980, eruption, huge volumes of volcanic debris dammed preexisting streams. Because these dammed streams are composed of loose materials, they are structurally weak. If the dams fail, mudflows and floods can occur. Loose volcanic debris on steep slopes is also vulnerable to flowing during or after heavy rainfalls. The risk of mudflows and floods is greatest on Mount St. Helens during the winter months when precipitation is heaviest and the snowpack is thickest.

Activity 1 Forecasting the Path of Mudflows

30-minute demonstration

45-minute work session

Students participate in a **demonstration** that will help them visualize the consistency of mudflows and how they move down stream valleys away from a volcano's summit or flanks. In a **work session**, students use topographic maps of Mount St. Helens before the 1980 eruptions to forecast the path mudflows might take during an eruption.

Key teaching points

1. Volcanic avalanches and volcanic mudflows are somewhat similar, but different in one important respect. Both can contain (a) volcanic debris, such as tephra of varying sizes ejected during an ongoing eruption, and (b) lava and rocks from previous eruptions that were deposited on the volcano's slopes. Mudflows, however, are mixtures of volcanic debris and water. Volcanic avalanches lack the water of mudflows.
2. Sources of water can include the (a) breakout of a volcanic or glacial lake, (b) melting snow and glacier ice, (c) streams and rivers that flow down the flanks of a volcano, and (d) intense rainfall.
3. Mudflows behave differently than avalanches. Because water acts as a lubricant, mudflows travel farther than avalanches. Both avalanches and mudflows can move very fast.
4. Mudflows move downslope and into stream valleys.
5. Being able to forecast the path of mudflows is important to scientists who assess the potential hazards of volcanic eruptions. The chief threat to people is burial. Structures are at risk of being buried, carried away, or collapsing.

Materials

Demonstration

1. Newspapers
2. Large plastic tarp, 9' x 12'
3. Rocks, bricks, or tent stakes to hold the tarp in place
4. Buckets

5. Large spoons or other sturdy stirring instruments
6. One paper cup for each student
7. Sand and gravel
8. Water

Work Session

1. Activity Sheet 4.1a-b
2. Transparencies made from Master Sheet 4.1 and Activity Sheet 4.1b.
3. Overhead projector

Procedures:

Simulating an avalanche and mudflow

1. Outdoors, construct a mockup of a volcano by crumbling up newspapers and piling them into the shape of a volcano.
2. Place a tarp over the newspapers. Make sure the tarp is large enough to simulate a flat area at the volcano's base. Also, create plenty of "hills" and "valleys." For ideas, refer to the photographs on the poster and to the topographic map on Activity Sheet 4.1b.
3. Place bricks, rocks, or tent stakes around the base of the tarp to keep it from moving.
4. Tell students that they will be creating an avalanche. Ask them to forecast the path the avalanche will take.
5. **Create an avalanche:**
 - Distribute paper cups and fill them with sand.
 - Pour the contents onto the top of the volcano to simulate an avalanche.
 - Repeat with gravel and then again with a mixture of sand and gravel.
 - Have students observe where the materials slide and which particles move fastest.
 - Discuss why. (Gravity pulls the materials downslope. The heaviest particles move fastest; the smallest particles move the farthest because they require less energy to move them.)
6. **Create a mudflow:**
 - In a bucket, mix water with sand and gravel to make a slurry.
 - Distribute paper cups and fill them with the slurry.

- Pour the slurry onto the top of the volcano.
- Discuss: Where did the mudflow flow? (It should go into the valleys.) Did it behave differently than the avalanche? What happens when the avalanche hits the flat area at the base of the volcano? (Slows down)

Work Session:

Forecasting the path of mudflows

Based on what they saw in the demonstration, students use a topographic map of Mount St. Helens before the 1980 eruption to forecast the paths mudflows might take as a result of an eruption. The students then compare their maps with the map that shows the path the flows actually took following the May 18, 1980, eruption. (Master Sheet 4.1)

Distribute Activity Sheets 4.1a-b.

Note that the topographic map on Activity Sheet 4.1b is the same as Map A in Lesson 2 except that it (a) covers a more extensive area, (b) the contour interval is 150 meters instead of 100 meters, and (c) north is oriented toward the top of the map.

Discussion

1. Discuss the students' forecasts. Will mudflows follow stream valleys? Will mudflows occur on all sides of the volcano?
2. Show students a transparency of Master Sheet 4.1. Compare this map with the students' forecast maps.
3. Discuss why the south flank and the area to the south were relatively untouched by mudflows. (The lateral blast blew hot volcanic debris to the north.)
4. Using your transparencies, compare the extent of the glaciers on Mount St. Helens before and after the eruption. What happened to the glaciers? What happened to the ice in the glaciers? (It was melted by the heat of the eruption or was "ground up" by the avalanche)
5. Bring up the point that Mount St. Helens behaved in an unexpected way

Activity 2 The Dangers of Snow and Ice

that even the scientists did not anticipate. (For example, David A. Johnston, a USGS volcanologist, was monitoring Mount St. Helens on a ridge north of the volcano, well outside of the anticipated danger zone, or so he thought. At 8:30 a.m. on May 18, 1980, Dr. Johnston made his last radio transmission: “Vancouver, Vancouver, this is it!” No trace of him or his equipment has ever been found.)

fig. 2

The Snowline

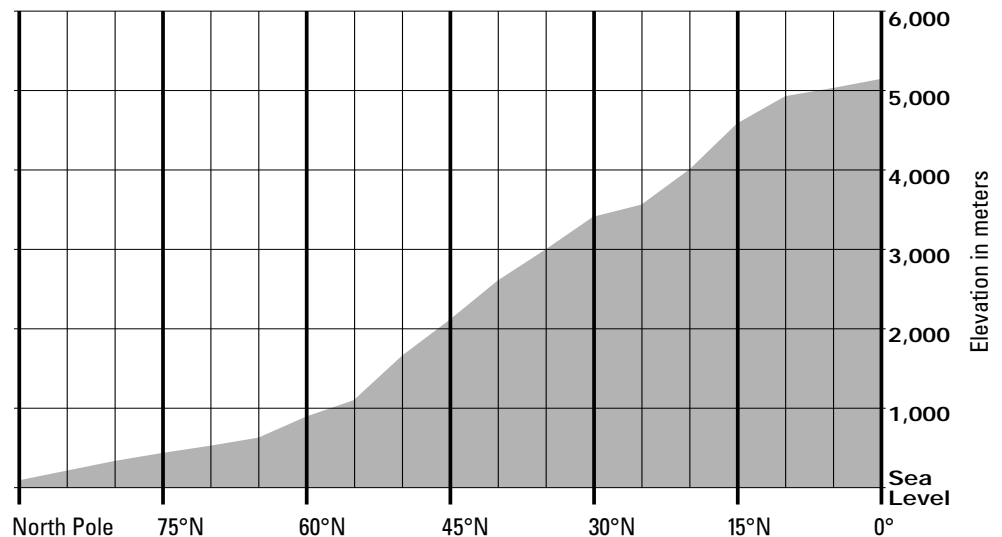

This diagram shows how the elevation of the snowline changes with latitude.

The approximate elevation of the snowline is indicated on this diagram where the white and black areas meet.

45-minute demonstration

45-minute work session

Students observe a **demonstration** of how melting snow and ice can contribute to mudflows and then learn in a **work session** why some volcanic mountains have permanent snow and ice.

Key teaching points

1. Some volcanic mountains have permanent snowpacks—snow that does not melt during the summer months. The lowest elevation at which snow remains on a mountain during the summer is called the **snowline**. (A mountain that has no snow in the summer has no snowline.) The snowline moves up and down a mountain seasonally—lowest in late winter and highest in late summer.

2. The snowline is related to air temperature, which in turn is influenced by elevation and distance from the Equator: air temperature drops as elevation increases and distance from the Equator increases. Even in areas near the Equator, there are some mountains that have snow year-round at their highest elevations, whereas in polar regions permanent snow can be found close to sea level during the summer months.

3. The snowline is highest—that is, less of the mountain is covered with snow in the summer—on mountains closest to the Equator. The snowline is lowest on land closest to the poles. The greater the distance from the Equator, the less elevation is necessary to establish a snowline. (fig. 2)

4. The snowline also is influenced by the amount of yearly snow fall. Thus, the snowline may not be the same for all mountains at the same latitude. (Generally, mountains closest to an ocean receive the greatest amounts of precipitation.)

5. Melted snow and glacial ice significantly contributed to creating the mudflows that followed the May 18, 1980, eruption of Mount St. Helens.

Materials

Demonstration

1. Potting soil, gravel, and water
2. Baking pan
3. Freezer
4. Bunsen burner

Activity 2 Continued

Work Session

1. Magazines
2. Large world map and push pins
3. Activity Sheet 4.2a–b
4. Transparency of “Snowline Diagram” (fig. 2)

Procedures

Demonstration

- 1. The day before the demonstration:**
In a baking pan, mix potting soil, gravel, and water to make a slurry. Place the baking pan in a freezer for at least 8 hours.
- 2. The next day:** Bring the frozen slurry into class. Set it up at a steep angle. Hold a Bunsen burner under the high end of the baking pan. (fig. 3). Observe the pan at 3-minute intervals. Wait for the slurry to melt.
- 3.** Point out to the students that this demonstration is similar to what happens when the heat of an eruption melts snow and ice on a volcanic mountain: water mixes with volcanic debris and creates mudflows.
- 4.** Look at poster figures 10 and 11 that show Mount St. Helens before and after the eruption.

Work Session:

- 1.** Make a transparency of the “Snow Line Diagram” (fig. 2).
- 2.** As a **homework or library assignment**, have students collect pictures of snow- and ice-covered mountains. Ask them to make a list of the names of the mountains and the countries or continents where they are located. (Collect your

own group of photographs to make sure that all of the continents are represented.)

- 3. In class**, make a list of continents on the chalkboard and compile the number of snow- and ice-covered mountains that the class found on each continent. Ask students if they expected to find snow-covered mountains in every continent.
- 4.** Remind students that when Mount St. Helens erupted on May 18, 1980, it was capped by snow and numerous glaciers. Ask students if they would expect to see snow in May.
- 5.** Distribute Activity Sheets 4.2a–b.
- 6.** Students first label a group of volcanoes on a blank map. After they complete this part of the activity, **ask them to stop.**
- 7.** Using a transparency, explain the “Snowline Diagram.” This chart shows how the snowline varies with elevation and latitude. **To plot a volcano and find its snowline :**
 - Find the approximate latitude of the volcano along the bottom of the chart and put a mark.
 - Keep one finger on that spot and then find the approximate elevation along the right hand side of the chart.
 - Put a mark where the two points come together. (For younger students, you may need to do this exercise as a class.)

- 8.** Explain the concept of a snowline to the class.

This teaching packet was originally published and printed in 1997. The online edition contains full text from

Activity Sheet 2 Answers

Part A

2. Nevada del Ruiz
3. 4°N
4. Surtsey, 63°N

Part B

- | | |
|----------------------|-----|
| 1. Mount Vesuvius | No |
| 2. Mount Etna | Yes |
| 3. Kilauea | No |
| 4. Mauna Loa | Yes |
| 5. Mount Rainier | Yes |
| 6. Mount Fuji | Yes |
| 7. Mount Pelée | No |
| 8. Katmai | Yes |
| 9. Lassen Peak | Yes |
| 10. Paricutin | No |
| 11. Surtsey | No |
| 12. Sunset Crater | No |
| 13. Mount St. Helens | Yes |
| 14. Nevada del Ruiz | Yes |

the original publication. Some images have been modified or added to improve the scientific visualization of information. This document has undergone official review and approval for publications established by the National Mapping Division, U.S. Geological Survey.

fig. 3

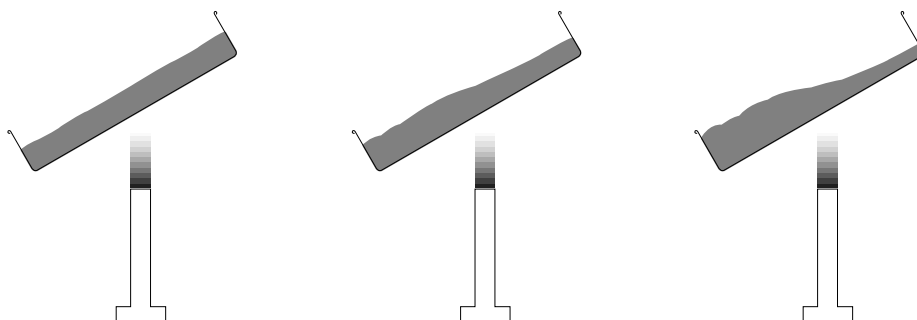

Master Sheet 4.1

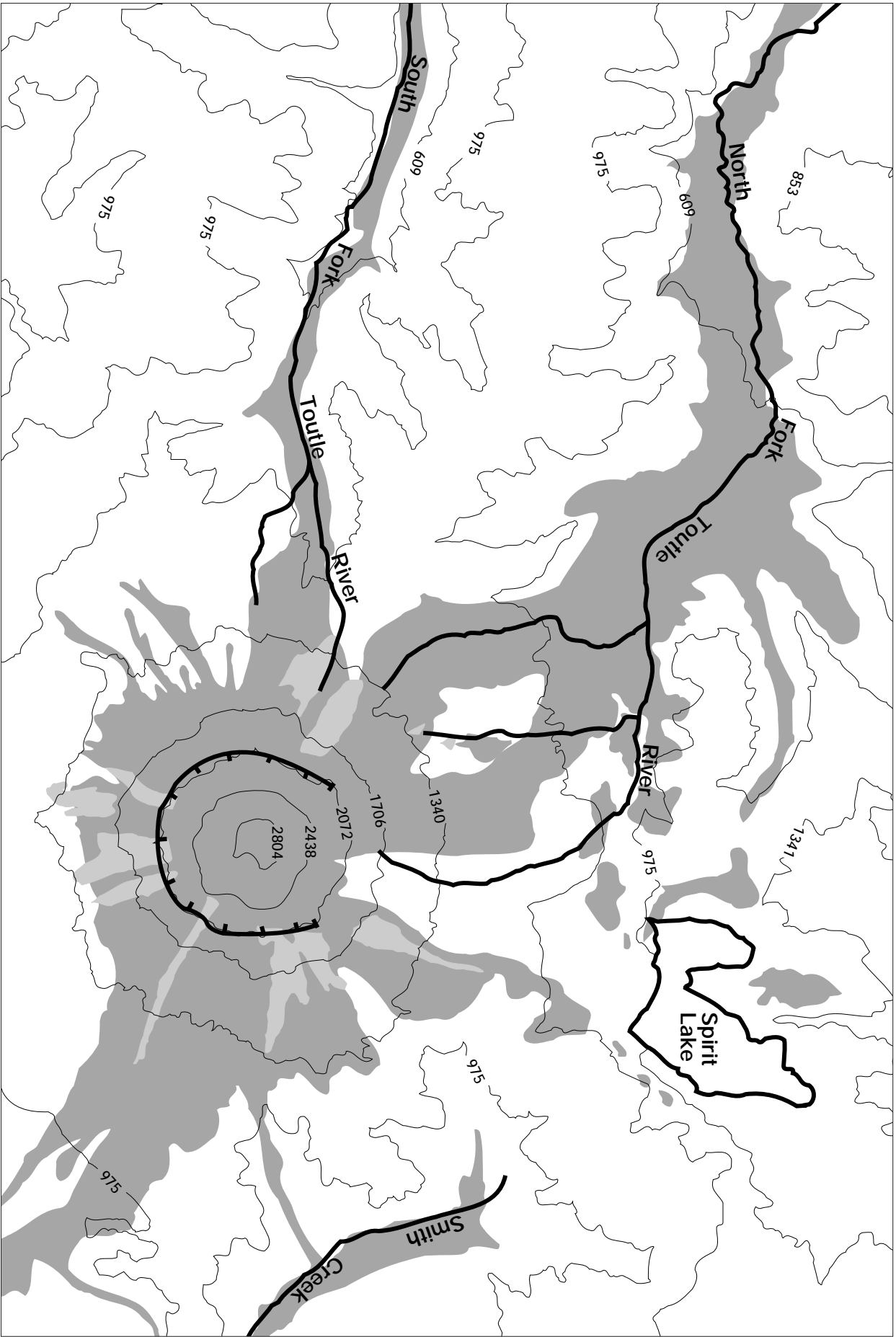

Legend



- Glaciers
- Mudflows

- Crater Rim
- Contour Interval 366 meters



VOLCANOES!

Activity Sheet 4.1b Forecasting the path of mudflows

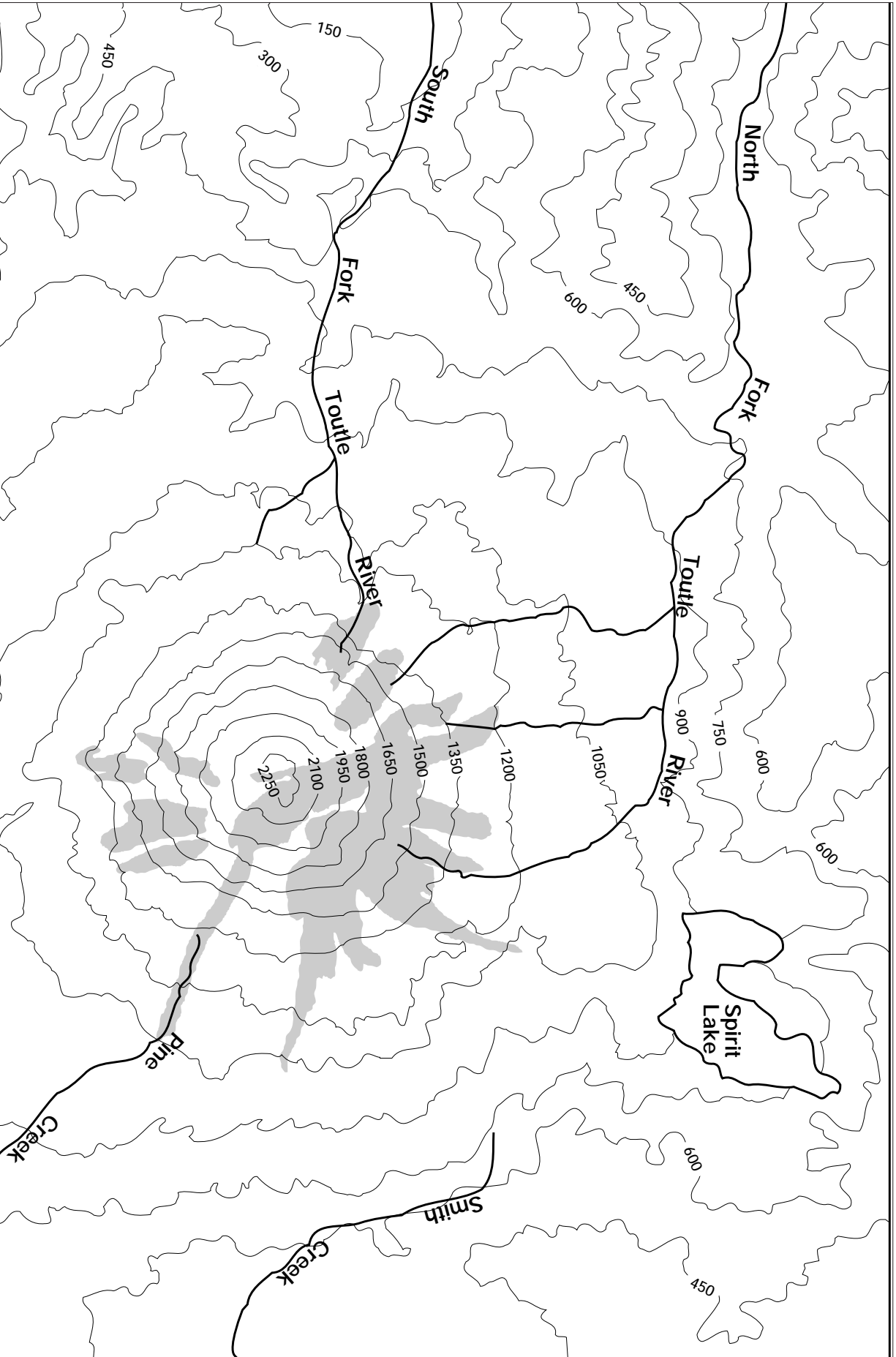

Glaciers
Contour Interval
150 meters



Legend

VOLCANOES!

Activity Sheet 4.2a The Snowline

In some mountains, there are areas where snow and ice stay all year. The elevation above which the snow stays all year is called the **snowline**.

The snowline differs on volcanoes depending on how far a volcano is from the Equator and the volcano's elevation.

What to do — Part A

1. Label the volcanoes listed below on the blank map. (All the volcanoes are north of the Equator.) Write the volcano's elevation on the map.

Volcano	Location	Elevation in meters
1. Mount Vesuvius	40N 14E	1,281 (Italy)
2. Mount Etna	37N 15E	3,350 (Italy)
3. Kilauea	19N 155W	1,222 (USA)
4. Mauna Loa	8N 157W	4,170 (USA)
5. Mount Rainier	46N 121W	4,392 (USA)
6. Mount Fuji	35N 138E	3,776 (Japan)
7. Mount Pelée	14N 61W	1,397 (Martinique)
8. Katmai	58N 154W	2,047 (USA)
9. Lassen Peak	40N 121W	3,187 (USA)
10. Parícutin	19N 102W	1,780 (Mexico)
11. Surtsey	63N 20W	155 (Iceland)
12. Sunset Crater	35N 111W	2,447 (USA)
13. Mount St. Helens	46N 122W	2,549 (USA)
14. Nevada del Ruiz	4N 75W	5,321 (Colombia)

2. Which volcano is closest to the Equator?

What is its latitude?

3. Which volcano is farthest from the Equator?

What is its latitude?

4. Would a volcano at 10°N be closer to the Equator than a volcano at 45°N?

(Latitude shows us distance from the Equator.)

What to do — Part B

Use the Snowline Diagram to find out which of the volcanoes on your map will have snow on them during the summer.

1. For volcano #1, find its latitude along the bottom of the chart. Put a mark there.
2. For volcano #1, find its elevation in meters along the right hand side. (Round off to the nearest thousand.) Put a mark there.
3. Put a mark where the two points come together. Is the mark above the dark area of the diagram? If yes, that volcano is likely to have snow on it during the summer.
4. If the volcano is likely to have snow on it during the summer, put a * next to it on the list of volcanoes.
5. Repeat steps 1-4 for all of the volcanoes on the list.

Snowline Diagram

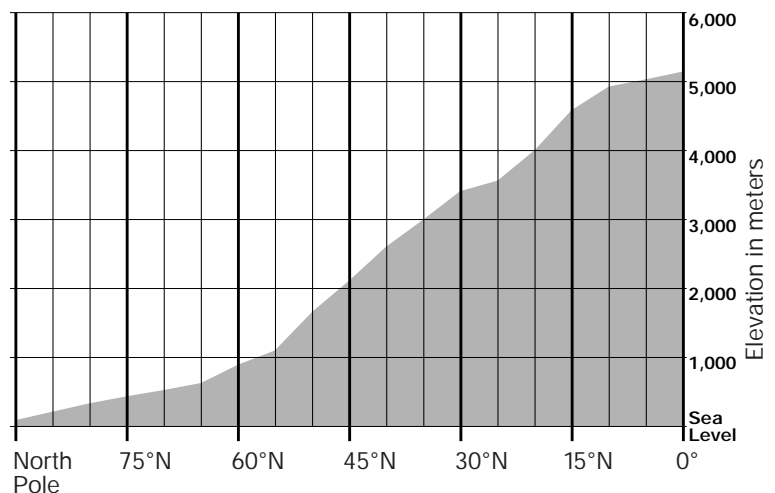

This diagram shows approximately how the elevation of the snowline changes with latitude.

VOLCANOES!

Activity Sheet 4.2b The Snowline

