



United States
Department of
Agriculture

Forest Service

Forest
Products
Laboratory

Research
Paper
FPL-RP-582



Environmental Impact of Preservative-Treated Wood in a Wetland Boardwalk

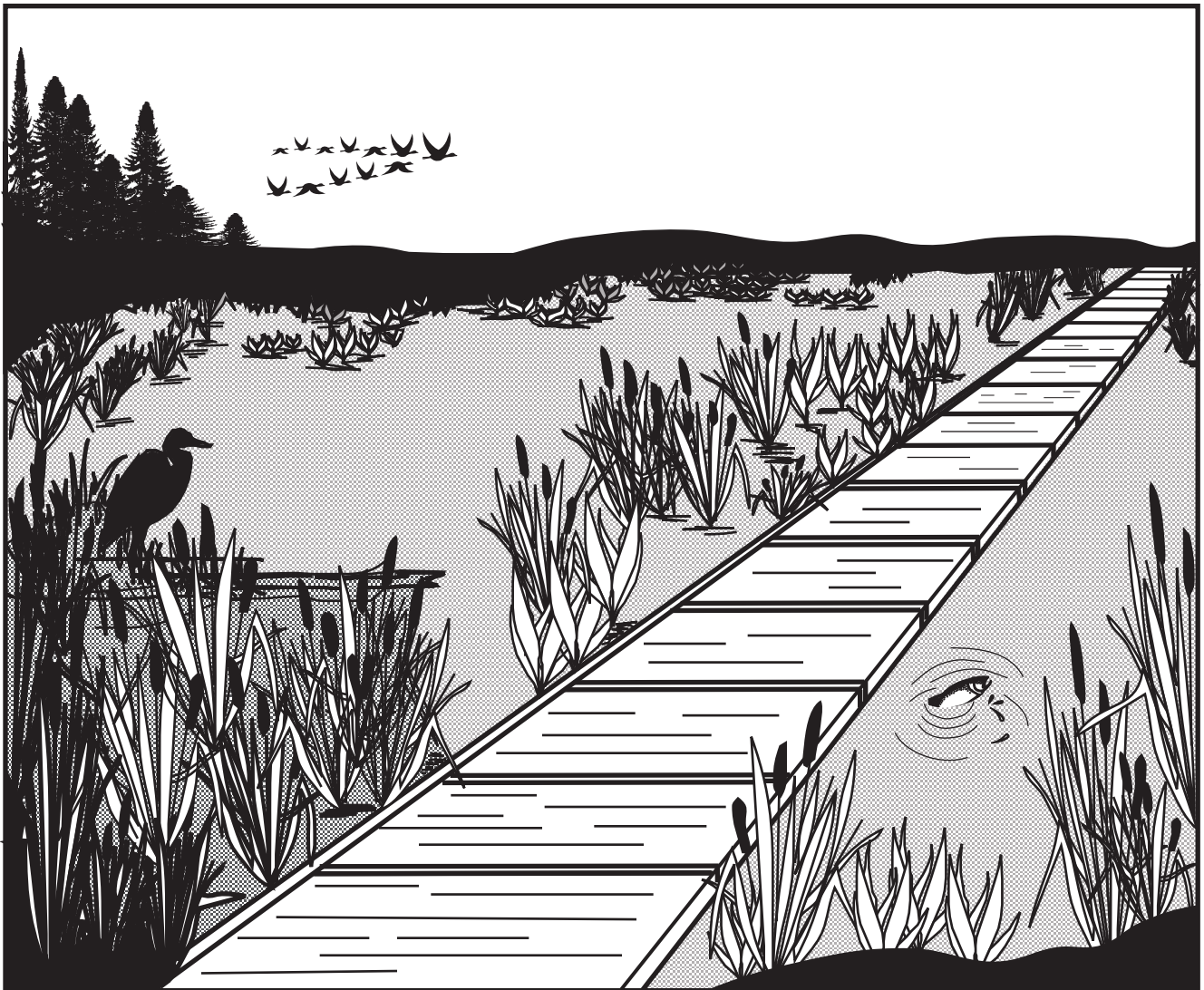

Abstract

Forest Service, Bureau of Land Management, and industry partners are cooperating in a study of the leaching and environmental effects of a wetland boardwalk. The construction project is considered “worst case” because the site has high rainfall and large volumes of treated wood were used. Separate boardwalk test sections were constructed using untreated wood or wood treated with ammoniacal copper quat Type B (ACQ-B), ammoniacal copper zinc arsenate (ACZA), chromated copper arsenate Type C (CCA-C), or copper dimethyldithiocarbamate (CDDC). Part I of this report focuses on leaching of preservative components. Surface soil, sediment, and water samples were removed before construction and at intervals after construction to determine the concentrations and movement of leached preservatives. The preservatives released measurable amounts of copper and/or chromium, zinc, or arsenic into rainwater collected from the wood, and elevated levels of preservatives were found in the soil and/or sediment adjacent to the treated wood. With few exceptions, elevated environmental concentrations of preservative components were confined to within close proximity of the boardwalk.

February 2000

Forest Products Laboratory. 2000. Environmental impact of preservative-treated wood in a wetland boardwalk: Res. Pap. FPL-RP-582. Madison, WI: U.S. Department of Agriculture, Forest Service, Forest Products Laboratory. 126 p.

A limited number of free copies of this publication are available to the public from the Forest Products Laboratory, One Gifford Pinchot Drive, Madison, WI 53705-2398. Laboratory publications are sent to hundreds of libraries in the United States and elsewhere.

The Forest Products Laboratory is maintained in cooperation with the University of Wisconsin.

The use of trade or firm names is for information only and does not imply endorsement by the U.S. Department of Agriculture of any product or service.

The United States Department of Agriculture (USDA) prohibits discrimination in all its programs and activities on the basis of race, color, national origin, sex, religion, age, disability, political beliefs, sexual orientation, or marital or familial status. (Not all prohibited bases apply to all programs.) Persons with disabilities who require alternative means for communication of program information (Braille, large print, audiotope, etc.) should contact the USDA's TARGET Center at (202) 720-2600 (voice and TDD). To file a complaint of discrimination, write USDA, Director, Office of Civil Rights, Room 326-W, Whitten Building, 1400 Independence Avenue, SW, Washington, DC 20250-9410, or call (202) 720-5964 (voice and TDD). USDA is an equal opportunity provider and employer.

Part II of this report focuses on the effects of boardwalks treated with CCA, ACZA, and ACQ-B on populations of aquatic invertebrates. The experimental variables were total species richness (total number of taxa), total sample abundance (number of organisms/sample), dominant sample abundance ($\geq 1\%$ total specimens in vegetation, artificial substrate, and infaunal samples), and Shannon's and Pielou's indices. The infaunal samples contained the largest mean number of animals and the highest total taxa richness. Although measurable increases occurred in water column and sediment preservative concentrations, no taxa were excluded or significantly reduced in number by any preservative treatment.

Keywords: waterborne wood preservative, ACQ-B, ACZA, CCA-C, CDDC, leaching, wetland, boardwalk, environmental sampling

Contents

	<i>Page</i>
Part I. Leaching and Environmental Accumulation of Preservative Elements <i>by Stan T. Lebow, Patricia K. Lebow, and Daniel O. Foster</i>	
Introduction	3
Objectives	7
Materials and Methods	8
CCA Studies	17
ACZA Studies	28
ACQ-B Studies	40
CDDC Studies	45
General Results and Discussion	47
Summary	49
References	50
Appendix IA—Framing Details for Typical Boardwalk Sections and Viewing Platforms.....	54
Appendix IB—Overview of Test Sections and Sampling Transects.....	60
Appendix IC—Preservative Concentrations.....	61
Part II. Environmental Effects <i>by Kenneth M. Brooks</i>	
Introduction	73
Materials and Methods	88
Study Endpoints	94
Results	95
Summary of Wildwood Boardwalk Study.....	119
Acknowledgments	121
References	121
Appendix—Terms for Variables and Inventory of Taxa.....	125

Environmental Impact of Preservative-Treated Wood in a Wetland Boardwalk

**USDA Forest Service
Forest Products Laboratory
Madison, Wisconsin**

Part I. Leaching and Environmental Accumulation of Preservative Elements

Stan T. Lebow, Patricia K. Lebow, and Daniel O. Foster

Summary

In Part I of this study, surface soil, sediment, and water samples were removed before construction and at intervals after construction to determine the concentrations and movement of leached preservative elements. During the first year, each preservative released measurable amounts of copper and/or chromium, zinc, or arsenic into rainwater collected from the wood. Each preservative also appeared to elevate levels of respective preservative components in the soil and/or sediment adjacent to the treated wood to varying extents. In some cases, this effect appeared to peak soon after construction, while in other cases environmental levels appeared to increase during the course of the year. With few exceptions, elevated environmental concentrations of preservative components were confined to within close proximity of the boardwalk.

Contents

	<i>Page</i>
Introduction	3
Objectives	7
Materials and Methods	8
Site Selection and Layout	8
Site Characteristics	9
Preservative Treatments	11
Boardwalk Design and Construction	12
Realistic “Worst-Case” Conditions	12
Construction and Sampling Schedule	13
Sampling and Analysis Protocol	13
Assessment of Wood Preservative Efficacy	16
Statistical Analysis	16
CCA Studies	17
Background CCA Levels	17
Rate of CCA Release in Rainfall	17
Accumulation and Mobility of CCA in Soil	18
Accumulation and Mobility of CCA in Sediment	22
Comparison of Soil and Sediment CCA Levels	27
Effect of Pre-Stain on CCA Release	28
Conclusions From CCA Studies	28

ACZA Studies	28
Background ACZA Levels	28
Rate of ACZA Release in Rainfall	28
Accumulation and Mobility of ACZA in Soil	29
Accumulation and Mobility of ACZA in Sediment	34
Comparison of Soil and Sediment ACZA Levels	40
Conclusions From ACZA Studies	40
ACQ-B Studies	40
Background Copper Levels	40
Rate of Copper Release in Rainfall	40
Accumulation and Mobility of Copper in Soil	41
Accumulation and Mobility of Copper in Sediment	43
Comparison of Soil and Sediment Copper Levels	43
Conclusions From ACQ-B Studies	45
CDDC Studies	45
Background Copper Levels	45
Accumulation and Mobility of Copper in Soil	45
Conclusions From CDDC Studies	47
General Results and Discussion	47
Mobility of Preservative Components in Wetland	47
Evaluation of Durability	49
Evaluation of Corrosion	49
Summary	49
References	50
Appendix IA—Framing Details for Typical Boardwalk Sections and Viewing Platforms	54
Appendix IB—Overview of Test Sections and Sampling Transects	60
Appendix IC—Preservative Concentrations	61

Part I. Leaching and Environmental Accumulation of Preservative Elements

Stan T. Lebow, Research Forest Products Technologist
Patricia K. Lebow, Mathematical Statistician
Daniel O. Foster, Chemist
 Forest Products Laboratory, Madison, Wisconsin

Introduction

Because preservative-treated wood is an economical, durable, and aesthetically pleasing building material, it is a natural choice for construction projects in the National Forests, National Parks, and other public and private lands. Wood preservatives such as chromated copper arsenate (CCA) and ammoniacal copper arsenate (ACA) have been shown to extend the useful life of treated wood by 45 years or more (Gutzmer and Crawford 1995). The use of preservative-treated wood also reduces the number of trees that must be cut to replace wood that has decayed in service. The most widely used wood preservative is CCA Type C (CCA-C), a waterborne wood preservative that is inexpensive, leaves a dry, paintable surface, and provides excellent protection against attack by decay fungi and insects. Another effective waterborne preservative, ammoniacal copper zinc arsenate (ACZA), is commonly used on the West Coast and in other areas when specifiers request wood species that are difficult to treat. Wood treated with CCA-C and ACZA is used extensively by the Forest Service and other government and private entities in the construction of structures such as walkways, piers, restraining walls, and bridges. In recent years, other types of wood preservatives such as ammoniacal copper quat (ACQ-B), amine copper quat (ACQ-D), ammoniacal copper citrate (CC), and copper dimethyldithiocarbamate (CDDC) have been standardized for use in similar applications (Table I-1).

Table I-1—Composition of waterborne formulations as specified by AWP Standards^a

Preservative	Composition (%)					
	CuO	As ₂ O ₅	CrO ₃	ZnO	DDAC ^b	SDDC ^c
CCA-C	18.5	34.0	47.5			
ACZA	50.0	25.0		25.0		
ACQ-B	66.7				33.3	
CDDC	17-29 ^d					71-83 ^d

^aAWPA 1997.

^bDidecyl dimethylammonium chloride.

^cSodium dimethyldithiocarbamate.

^dStandard calls for weight ratio between 5:1 and 2.5:1 SDDC:copper in treated wood.

Many applications for preservative-treated wood are situated in pristine and/or sensitive ecosystems where contamination by significant amounts of wood preservative components could negatively affect the environment. Concerns about wood preservative leaching and environmental impacts have risen in recent years, generating pressure to restrict or reduce Forest Service use of treated wood in some types of environments. These environmental concerns have become particularly acute in the Pacific Northwest, and the use of treated wood has not been permitted in several Forest Service boardwalk construction projects. This issue has been difficult to resolve because of lack of data on leaching and biological impacts of wood preservatives, particularly for wood in service (Tippie 1993). Much data on preservative leaching is limited to CCA-C, and tests were conducted on small specimens that tend to accelerate leaching. Results from these studies are conflicting and difficult to relate to leaching under in-service conditions (Lebow 1996).

Perhaps the most pertinent study of leaching from CCA-C treated wood was conducted by the Tasmanian Parks and Wildlife Service (Comfort 1993). In this study, which was conducted to address many of the same concerns faced by the Forest Service in the United States, levels of chromium, copper, and arsenic adjacent to CCA-treated boardwalks were measured at several sites in southern Tasmania. At each site, three soil samples were taken within 150 mm (6 in.) of the boardwalk and three reference samples were removed several meters away from the boardwalk. The boardwalks varied from 1 to 14 years in age; the preservative retention and treating solution formulation were not reported. Levels of copper and chromium adjacent to the track were significantly elevated in comparison to the control samples, but not to extreme levels. Arsenic levels were not found to be significantly elevated above the controls. The highest copper level detected was 49 ppm (controls between 1 and 3 ppm) and the highest chromium level 88 ppm, approximately 60 ppm above the reference sample. No apparent relationship was detected between the age of the boardwalk and preservative component levels; the highest copper levels were detected around a 1-year-old boardwalk and the highest chromium levels around the 14-year-old boardwalk.

This elevation of chromium levels in the soil is surprising relative to the copper and arsenic levels detected. Most other studies have indicated that copper and arsenic are leached in greater quantities than is chromium. It is possible that in Comfort's study, the copper and arsenic were more mobile in the soil and that levels had dissipated over time. However, none of the sites was sampled immediately after installation or repeatedly sampled over time, so it is difficult to ascertain if copper and arsenic levels had been higher originally. In addition, no copper or arsenic analyses were done at the sites that contained the highest chromium levels; the levels of these two components may have also been more elevated at these two sites.

In another study, the results of which are applicable to boardwalk decking, Stilwell and Gorny (1997) collected soil samples from beneath residential decks constructed from wood treated with CCA-C. Substantially higher levels of CCA-C components were detected in this study compared with the Tasmanian study. Several samples taken from under the decks contained more than 100 ppm copper, and a maximum level of 410 ppm copper was detected under one deck; in some samples chromium concentrations were also elevated to more than 100 ppm and maximum arsenic concentrations of 200 to 300 ppm were reported (Stilwell and Gorny 1997). Overall, the average copper, chromium, and arsenic levels detected under the decks were 75, 43, and 76 ppm, respectively, whereas levels detected in nearby "control" areas were 17, 20, and 4 ppm, respectively. The concentration of CCA components in the soil decreased rapidly with soil depth. In contrast to results from the Tasmanian study, Stilwell and Gorny did note an increase in soil levels with increasing age of the deck. However, their study was limited in that it was conducted in a residential area with many alternative sources of soil contamination and no background or preconstruction samples were possible. In addition, the authors did not attempt to estimate the effects of contamination on biological organisms in the area.

Very few reports have been published on leaching of CCA from in-service structures exposed in freshwater applications. However, one study did assess waterway contamination from lock gates constructed from lumber treated with CCA (Cooper 1991). Water samples were collected above and at varying distances below a newly constructed lock gate and a gate that had been in service for 5 years. No elevated CCA component levels were found in water around the older gate, but significantly elevated levels of all three CCA components were detected in water downstream from the newly installed gate. Copper levels in the water were elevated by approximately 200 ppb (parts per 10^9) adjacent to the gate and 400 ppb at 40 m (131 ft) downstream, chromium levels were elevated by approximately 100 ppb in both locations, and arsenic levels were elevated by approximately 90 ppb near the gate and 60 ppb at 40 m (131 ft) downstream.

Because ACZA is not as widely used as CCA-C, little information is available on the rate of copper release from treated wood in service. Leaching of arsenic from wood treated with ACA and ACZA was compared in two watering trough studies (Anonymous 1985). In these studies, watering troughs with inside dimensions of 600 by 277 by 2,051 mm (24.5 by 10.9 by 80.75 in.) were constructed with Douglas-fir lumber that had been treated with either ACA (1982 study) or ACZA (1985 study). The troughs were filled with tap water and allowed to stand for 4 h, and a water sample was then removed from the center of the trough at one-half the water depth. This process was repeated twice. The samples removed from the ACA-treated trough contained 1,630, 760, and 330 ppb arsenic for the first, second, and third water additions, respectively. The samples removed from the ACZA-treated trough contained 19, 17, and 2 ppb arsenic after the same series of water changes. Analysis of the tap water revealed that it also contained 2 ppb arsenic. Although the lack of replication does not allow estimation of variation within sampling points, this study demonstrates the vast improvement in arsenic leach resistance achieved by the addition of zinc to the ACA formulation, as well as the tendency for the majority of leaching to occur early in exposure. Another ACZA leaching test was conducted on 610-mm- (24-in.-) long Douglas-fir pole stubs that had been treated to 15.5 kg/m^3 (0.97 lb/ft^3). The author reported an overall leaching rate of 0.14 mg/L after 2 months of exposure (Morgan 1989).

Some field leaching data are available for ACA, but results from the anonymous 1982 study and from small-block laboratory comparisons indicate that leaching, at least of arsenic, is substantially reduced in the ACZA formulation (Best and Coleman 1981, Lebow 1992, Rak 1976). In addition, the fixation of copper might be expected to be substantially different in the ACA and ACZA formulations, as much copper in ACA is thought to precipitate as copper arsenate complex whereas copper precipitation in ACZA is more likely to occur in the form of copper carbonate.

Because ACQ-B is a relatively new preservative, little information is available on the rate of copper release from treated wood in service. However, studies have been conducted on small specimens with the intention of accelerating leaching. Copper release from ACQ-B, CCA-C, and ACZA was compared in a soil-bed test using 1.9-by 0.8- by 20.0-cm (0.75- by 0.30- by 7.90-in.) stakes (Jin and others 1992). After 9 months, copper loss from stakes treated to 9.6 kg/m^3 (0.6 lb/ft^3) averaged 19% from ACQ-B, 30% from ACZA, and 17.9% from CCA-C. In a subsequent soil-bed test using 0.5- by 1.9- by 20.3-cm (0.25- by 0.75- by 8.00-in.) Southern Pine stakes treated to 6.4 kg/m^3 (0.4 lb/ft^3) with ACQ-B, 19.4% of copper was lost within 3 months (Anon. 1994). The leaching conditions in these studies were very severe because of the small stake size and the soil-bed conditions. ACQ-B leaching data were also collected from 44-month

ground-contact depletion tests conducted in Hilo, Hawaii using 1.9- by 1.9- by 100.0-cm (0.75- by 0.75- by 39-in.) stakes treated to 6.4 kg/m³ (0.4 lb/ft³) (Jin and others 1992). Averaging losses from the top, bottom, and middle of the stakes revealed a loss of 19% copper.

Aboveground depletion tests were conducted in Hawaii using 5.0- by 1.9- by 35.0-mm (2.0- by 0.75- by 14.0-in.) Southern Pine samples treated with CCA-C and ACQ-B (Jin and others 1992). After 12 months, copper loss from stakes treated to 4 kg/m³ (0.25 lb/ft³) was 14% from ACQ-B and 8% from CCA-C. All of the tests by Jin and others were intended for comparative purposes and used small dimensions that greatly accelerated copper release. The rate of copper release would be expected to be much lower from the size of material used in service, but published data are lacking for this type of leaching test.

Because CDDC is a recently developed preservative, very little information is available on its potential for in-service leaching. Long-term (23-year) leaching data have been reported for 19- by 19- by 457-mm (0.75- by 0.75- by 18-in.) Southern Pine stakes exposed in Bainbridge, Georgia (Freeman and others 1994). The stakes had been treated to either 9.6 kg/m³ (0.6 lb/ft³) with CCA or to 3.5 kg/m³ (0.22 lb/ft³) (as copper) with a CDDC formulation in which copper sulphate was the copper source. Copper retentions in the above- and below-ground portions of the stakes were compared to estimate preservative leaching. Below-ground portions of CDDC-treated stakes had 77% less copper than did aboveground portions; below-ground portions of CCA-C-treated stakes had 72% less copper than did aboveground portions. Actual copper losses may have been higher because some leaching does occur above ground.

Subsequently, fungal cellar leaching tests were conducted on 3- by 19- by 154-mm (0.12- by 0.75- by 6-in.) Southern Pine stakes treated to copper retentions of 0.64, 1.12, 1.76, and 2.72 kg/m³ (0.04, 0.07, 0.11, and 0.17 lb/ft³) (copper ethanolamine formulation) or to 0.48, 0.80, 1.76, and 2.24 kg/m³ (0.03, 0.05, 0.09, and 0.14 lb/ft³) (copper sulphate formulation) (Arsenault and others 1993). Copper loss decreased with increasing retention and appeared to be higher for the copper sulphate formulation than for the copper ethanolamine formulation. Losses varied from 14% (low retention CuSO₄) to 0% at all the higher retentions of the copper ethanolamine formulations. The SDDC losses were much higher, ranging from 99% at the lowest retention to 40% at the highest retention. These leaching rates may sound extreme, but it is important to remember the length of the test and the fact that small stakes lose a much greater percentage of their preservative than does product-size material.

The majority of past research on preservative leaching has taken the form of laboratory studies designed to compare the effects of various factors on leaching or to compare leaching rates of various preservatives. Although these studies are

very useful as comparative tools, they are not intended to demonstrate the amount of leaching that may occur in service conditions. Many factors that may influence leaching in service are difficult to simulate in a laboratory; exposure environment, product size, and surface area are examples. Although experimental conditions are more difficult to control in field or service leaching studies, the results tend to be more useful indicators of actual leaching amounts. However, information about leaching gained from these studies must be evaluated with respect to exposure conditions and product type.

One factor that affects the rate of preservative release is the amount of time that the treated wood has been exposed in the environment. In general, the majority of leaching from wood treated with waterborne preservatives, while in service or in laboratory tests, occurs upon initial exposure to the leaching medium. Although the overall amount of leached preservatives can be relatively small, an initial wave of readily available and unfixed or poorly fixed preservatives moves out of the wood, followed by a rapid decline to a more stable leaching rate (Bergholm 1992, Evans 1987, Fahlstrom and others 1967, Fowlie and others 1990, Merkle and others 1993, Teichmann and Monkan 1966). This trend is most obvious for the very tightly bound chromium in CCA, which leaches very little after initial releases upon exposure (Bergholm 1992; Sheppard and Thibault 1991). However, this time-dependent leaching pattern will depend on the size of the treated product, the amount and type of surface area exposed, and the extent to which the preservative components are fixed. Because the highest rate of preservative leaching occurs initially, products that have not made a significant environmental impact within the first few years are not likely to do so in the future.

The rate and overall amount of leaching from a given product is also affected by preservative penetration and retention and by the surface area of the product. A deeply penetrated utility pole, with a reservoir of chemical at some distance from the pole surface, would be expected to show a much more gradual decrease in leaching than would a small stake. Arsenault (1975) noted that CCA levels in soil around poles were higher than those around posts because the exposed surface area of the poles was much larger. It is partly this factor that complicates the use of data from small laboratory specimens to predict leaching in service. The type of grain exposed can also influence leaching characteristics. The American Wood Preservatives Association (AWPA) standard 19-mm (3/4-in.) cubes used for leaching trials (AWPA 1997) greatly accelerate leaching not only because of their small dimensions but also because the proportion of exposed end grain is many times greater than that of most products in service. Leaching of CCA has been shown to be highest from exposed end grain in seawater exposures (Shelver and others 1991) and higher from flat-grain than edge-grain Douglas-fir exposed in cooling towers (Gjovik and others 1972). In another study,

leaching of CCA-C leaching from round post sections was reported to be higher than that from sawn lumber with a similar surface area (Van Eetvelde and others 1995). The authors theorized that the post dimensions may have caused slower fixation or that the posts may have had a higher proportion of permeable sapwood. A similar effect has been noted with wood species; more permeable species tend to leach at a higher rate because of more rapid movement of leachate (Cockroft and Laidlaw 1978, Wilson 1971).

Interpretation of CCA-C leaching data is also made difficult by differences in the formulation of CCA-C. Many of the older studies, as well as recent European studies, used CCA-C prepared from "salt" based ingredients (copper sulphate, sodium dichromate) instead of "oxide" based ingredients (cupric oxide, chromium trioxide) used by North American CCA-C manufacturers.

An important factor in determining both the mobility and toxicity of leached preservative components is the form in which they leave the wood. Chromium and arsenic, in particular, may exist in either of two relatively stable valence states, whose properties are very different. Copper and zinc are much less likely to remain stable in the environment in any form other than +2, and so the valence state leached is of much less concern. Generally, trivalent arsenic is many times more toxic than pentavalent arsenic and hexavalent chromium is many times more toxic than trivalent chromium, to most organisms (Ferguson and Gavis 1972, Stackhouse and Benson 1989). In addition, the different valence states of chromium and arsenic have very different solubilities and mobilities in the environment.

Arsenic within CCA- and ACZA-treated wood is generally assumed to be in the pentavalent valence state and chromium in the trivalent valence state. Woolson and Gjovik (1981) determined that only 3% of the arsenic washed from the surface of freshly CCA-treated wood was in the trivalent form, as was 3% to 7% of arsenic extracted from sawdust. However, they also noted that some arsenate in a mixture of CCA and sawdust was converted to arsenite over a period of several weeks.

Conversion of chromium from the hexavalent state in the treating solution to the trivalent state in the wood is assumed as the basic premise of CCA-C fixation. Considerable effort has been made to monitor the proportion of hexavalent chromium in extracted treating solution as a means of assessing degree of fixation (Cooper and Ung 1992a, 1993, Foster 1989, McNamara 1989), and the results generally show that the conversion to the trivalent state proceeds to completion under proper conditions. In addition, one researcher concluded that all the chromium present within fixed, treated wood was in the trivalent state (Wright 1989). Although the proportion of hexavalent chromium in the wood appears to be quite small, this form is more water soluble and less reactive with the wood than is the trivalent form and so it may be

expected to leach more readily. In addition, if fixation is not allowed to proceed to completion before the wood is exposed, the rates of total and hexavalent chromium leached could be much higher.

Exposure site factors can also be expected to affect leaching and environmental mobility of preservative components. Regardless of whether the treated wood is exposed above ground or in fresh water, salt water, sediments, or soil, water is the key to leaching of preservative components from wood and their subsequent movement through the surrounding substrate. Water acts as a medium for leaching of fixed preservative components in several ways. Even fixation products with very low water solubility can be gradually solubilized if enough water moves through the wood. In addition, the water may carry organic or inorganic components into the wood that either react with fixation products directly or alter the pH sufficiently to make the fixation products soluble. Alternatively, water may solubilize or erode portions of the wood that contain CCA components.

A study of run-off from CCA-treated pine roof boards revealed that concentrations of copper, arsenic, and chromium were higher when exposed to a drizzling rain than when exposed to heavy showers, but this trend may be more a result of dilution than of leaching (Evans 1987). Other work also suggests that for an equivalent amount of rainfall, more leaching is caused by slow steady rain than by intermittent heavy showers (Cockroft and Laidlaw 1978). Although little research has been done in this area, the volume of water flow around treated wood in ground contact might be expected to have conflicting effects on leaching. Although wet soils may allow for maximum solubility and transport of compounds into and out of the wood, high rates of water flow may also dilute the concentration of soil constituents that solubilize CCA fixation products. In a laboratory study, water temperature was also found to significantly affect leaching from wood treated with a CCA-C salt solution (Van Eetvelde and others 1995). In that study, copper, chromium, and arsenic leaching were approximately 1.4, 1.6, and 1.5 times greater, respectively, from wood leached at 20°C (68°F) than from wood leached at 8°C (46°F).

Once preservative components leave the wood, their movement is more affected by water volume and flow rate. Generally, arsenic and metals may either diffuse through soil as free ions or in complexes, be carried by the mass flow of a water front, or percolate through soil pores in particulate form (Dowdy and Volk 1983). Of these transport mechanisms, mass flow with a water front is probably most responsible for moving metals appreciable distances in soils (Dowdy and Volk 1983). This is especially true in highly permeable, porous sites where water moves through the soil quickly and is less affected by the chemical composition of the soil. For movement over long distances, the preservative components must either be in soluble form or attached to

soluble soil constituents (Dowdy and Volk 1983). Solubility is affected by many factors, including pH, ion adsorption sites, the presence of soluble ligands, and ionic strength. Consequently, there is significant interaction between the effects of the water and the soil itself.

The movement mechanisms of preservative components leached in water exposures are similar to that in soil, but variations occur because of the much greater ratio of water to solids. It is also apparent that elements leached into water have the potential for faster migration over much greater distances than those leached into soils. Factors that increase the solubility of the leached preservative components will lead to rapid dispersion in the water; factors that decrease solubility will cause accumulation in the sediment. Although decreased solubility and mobility of pollutants are usually considered desirable, this is not as clearly the case in aquatic exposures where bottom sediments are rich in biologic activity. When considering the fate of the low levels of components leached from treated wood, accumulation in sediment may be the primary concern, since the soluble components released are likely to quickly disperse to near background levels in large bodies of water.

Leaching and mobility of preservative components is potentially affected by the composition of soil, soil water, fresh water, or seawater. The exposure site pH may vary from below 4 in acid bogs to over 8 in hard water lakes, and the types of minerals solubilized vary accordingly. Suspended or solubilized compounds from soils or sediments may solubilize or precipitate preservative components and alter the pH. In addition, stationary soil or sediment constituents may serve as adsorption sites for preservative components. All of these factors influence chromium, copper, arsenic, and zinc solubility to various extents, although sorption to organic and inorganic ligands may be the most important process in determining the environmental fate of metals in the aquatic environment (Stackhouse and Benson 1989).

When considering the amounts of preservative components that may leach from treated wood, it is helpful to consider the levels of these elements that occur naturally in the environment. Chromium is a relatively common element, the 7th most abundant on earth (McGrath and Smith 1990). Chromium levels ranging from undetectable to as high as 10,000 ppm have been reported in soils, with average levels ranging from 6 to 200 ppm (Brown 1986, McGrath and Smith 1990). Naturally occurring chromium levels in water are much lower; although levels as high as 84 ppb have been reported; freshwater levels are generally below 5 ppb and seawater levels below 1 ppb (Brown 1986, Florence and Batley 1980, Spotte 1979). Copper levels in soil are also variable, ranging from 8 to 300 ppm and averaging from 15 to 30 ppm (Baker 1990, Brown 1986). In water, copper levels tend to be slightly higher than chromium levels, ranging from 0.8 to 105 ppb and averaging between 1 and 10 ppb (Brown 1986, Spotte 1979). Natural levels of arsenic in soils typically

range between 1 and 40 ppm, with most levels falling in the lower half of this range (O'Neill 1990). Soil arsenic levels are often much higher in agricultural areas because of the widespread use of arsenical insecticides in the past. Arsenic levels in water vary tremendously, with naturally occurring levels of more than 2 ppm in some hot springs, thermal waters, and even some well water (USDA 1980). In general, however, most fresh water in the United States has arsenic levels below 50 ppb, while arsenic levels in seawater typically range from 1 to 6 ppb.

Zinc composes 0.004% of the earth's crust, and it is the 25th most abundant element (Eisler 1993). The average concentration of zinc in United States soils is 40 ppm, with a range of 25 to 300 ppm reported. Freshwater zinc levels in the United States range from 0.5 to 10 ppb, while seawater levels worldwide range from 0.002 to 40 ppb. Sediments contain high but variable levels of zinc, with reported levels as high as 11,000 ppm in the United States. Very high levels of zinc are found in soil, water, and sediments in polluted areas (Eisler 1993).

Thus, many factors can influence preservative leaching and environmental mobility, and no single study can account for all of these factors. Further research is needed to address concerns about the use of treated wood in sensitive environments. One approach is to conduct the research in a manner that represents a "worst case" scenario that will overestimate impacts at most other sites. This is the approach being taken in the cooperative study reported here. This ongoing study is being conducted by members of the wood treating industry, the USDA Forest Service Forest Products Laboratory, Mt. Hood National Forest, and the Bureau of Land Management (Table I-2). The objectives of this study are to evaluate preservative release, preservative movement, and biological impacts from treated wood used in construction of an in-service wetland boardwalk.

Objectives

Part I of this report is focused on objectives 1 to 3; Part II is focused on objective 4.

1. To quantify the amount of wood preservative components that leach out of the wood during exposure
2. To determine the accumulation and extent of movement of preservative components in soil, sediment, and water at the exposure site
3. To determine the long-term efficacy (durability) of various types of preservative-treated wood in a severe decay hazard wetland environment
4. To determine the impact of the preservative systems on diversity and populations of aquatic invertebrates at the exposure site

Table I-2—Participants in study

Cooperator	Contact	Contribution
USDA Forest Service, Forest Products Laboratory	Stan Lebow	Administration, sample collection and analysis
Aquatic Environmental Sciences	Kenneth Brooks	Evaluation of biological impacts
Bureau of Land Management	Robert Ratcliffe, Bruce Runge	Design of boardwalk, oversight of construction
Western Wood Preservers' Institute preservative manufacturers	Dennis Hayward	Coordination of industry support
Chemical Specialties Inc.	Alan Preston, Lehong Jin	Funding for ACQ-B and CCA-C, assistance in study design
Hickson Corporation	William Baldwin	Funding for CCA-C, assistance in study design
ISK Biosciences	Craig McIntyre ^a	Funding for CDDC, assistance in study design, CDDC-treated wood
J.H. Baxter, Inc.	David Thies ^b , Richard Baxter	Funding for ACZA, assistance in study design
Osмосe, Inc.	Robert Inwards, William McNamara	Funding for CCA-C, assistance in study design
Treating plants		
Allweather Wood Treaters		Lumber for subsequent CCA-C treatment
Permapost Products Company		Fabrication of wood prior to CCA-C treatment
Exterior Wood, Inc.		Preservative treatment with CCA-C
J.H. Baxter, Inc.		ACZA-treated wood
Conrad Wood Preserving		Lumber and preservative treatment with ACQ-B
Timber Products Inspection		Inspection of treated wood for retention, penetration, and conformity to best management practice

^aCurrently with McIntyre Associates, Inc., Walls, Mississippi.

^bDeceased.

Materials and Methods

Site Selection and Layout

A site in the Pacific Northwest was selected for the study because some of the strongest objections to the use of treated wood have arisen in this region and because climatic conditions were expected to promote release of preservatives. The study was incorporated into a large boardwalk project at a Bureau of Land Management recreation site (Wildwood Recreational Area) approximately 64 km (40 mi) southeast of Portland, Oregon. Located adjacent to Mt. Hood National Forest at the 366-m (1,200-ft) elevation on the west side of the Cascade Mountains, the site is characterized by mild temperatures and high annual rainfall.

More than 549 m (1,800 ft) of boardwalk was constructed to allow access to viewing platforms overlooking stream, pond, and wetland habitats. Sections of the boardwalk that were spatially isolated and extended into wetland areas were selected for the study (Fig. I-1). Because the sections were

isolated from each other and extended away from the boardwalk, they allowed sampling with minimal risk of interference or effects from adjacent boardwalk areas.

Four preservative systems—CCA-C, ACZA, ACQ-B, and CDDC—were evaluated at different locations at the test site (Fig. I-1). These preservatives are currently being used or have the potential for use in boardwalk construction, decking, and similar applications. Because of rapid stream flow, the CDDC boardwalk section was judged to be unsuitable for biological impact testing, and so the CDDC evaluation was limited to soil copper evaluations. To allow the assessment of biological impact of the boardwalk construction, independent of preservative leaching, an additional short “dummy” (control) section of boardwalk was built from untreated Douglas-fir. This dummy section was installed in a portion of the wetland upstream from, but otherwise similar to, where the treated test sections were located (Fig. I-1). The remainder of the boardwalk was constructed from ACZA-treated wood, but it was not included in the study.

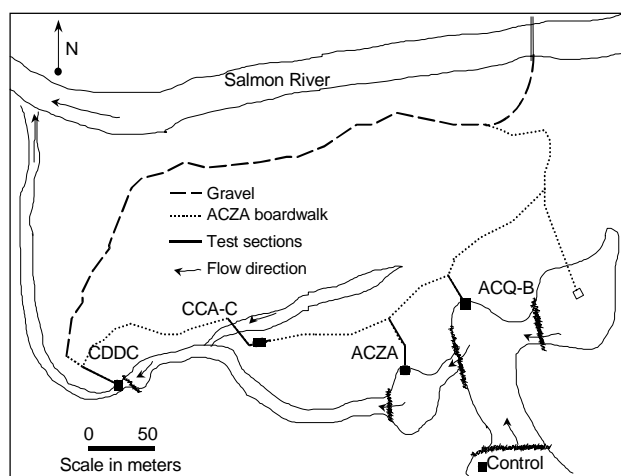

Figure I-1—Overview of test site showing locations of treated wood sections.

Note that this study was not intended to directly compare the leaching and biological impacts of the different preservative systems. Although the exposure environments were similar, some differences did exist in soil composition, water flow rates, and shading. The ACQ-B and ACZA test sections were constructed during steady rain and were exposed to more overall rainfall than were the CCA-C and CDDC sections. In addition, not all the preservatives were used with each wood species. A direct comparison of the systems would have also required replications of each preservative system within the same boardwalk spur, and this approach was not possible with the resources available for the study.

Site Characteristics

Soil

Soil characteristics in the riparian area of each boardwalk test section were evaluated by the Soil Physical Characterization

Laboratory at Oregon State University (Table I-3). Soil at the ACQ-B section contained less sand and more silt than did the other sections, whereas soil at the CCA-C section was characterized by high sand content. Clay content of the soil was low at all boardwalk sections.

Total carbon content and cation exchange capacity (CEC) are important indicators of the ability of a soil to adsorb and retain cations such as copper, zinc and chromium. Total carbon content in surface soils within the United States usually ranges from 1% to 6% (Bodek and others 1988). Total carbon content and CEC were relatively high at each boardwalk section. In the upper 150 mm (6 in.) of soil, carbon content ranged from 5.5% to 7.9% and CEC values ranged from 29.6 to 32.1 meq, in contrast to 2 to 17 meq typically reported for sandy loam soils. The high CEC values noted at the test site are more typical of silt loam (as classified at the ACQ test section) or clay loam soils (Bodek and others 1988). The combination of relatively high sand content and relatively high CEC of soils indicates that the soils allow simultaneous water movement and adsorption of preservative components. The soils appeared to be well drained; no standing water was observed at any of the sites even during sustained periods of heavy rain.

Rainfall

Rainfall at the site averages around 203 cm (80 in.) per year, although it was considerably higher during the course of this study. The majority of rainfall occurs from October through May; little rain falls in July and August. In this area, rain tends to take the form of a slow, steady drizzle, as opposed to sudden showers.

The pH of rainfall at the site, as measured at the Bull Run station approximately 16 km (10 mi) away, averages between 5.2 and 5.3, and it was reported as 5.2 for 1996 and 1997 (NADP/NTN, 1998). This pH is relatively high; pH of

Table I-3—Soil characteristics at each test site

Site	Soil depth (mm)	CEC ^a (meq/100 g)	Carbon ^b (%)	Sand ^c (%)	Silt ^c (%)	Clay ^c (%)	USDA textural classification
ACQ-B	0-150	32.1	5.8	42.8	51.2	6.0	Silt loam
	150-300	27.7	4.5	47.5	47.0	5.5	Sandy loam
ACZA	0-150	29.6	5.5	55.7	37.6	6.8	Sandy loam
	150-300	24.0	3.9	60.3	33.8	5.9	Gravelly sandy loam
CCA-C	0-150	29.6	7.9	71.2	22.9	5.9	Sandy loam
	150-300	23.6	4.4	70.2	22.3	7.5	Sandy loam
CDDC	0-150	31.4	6.8	55.2	36.9	7.9	Gravelly sandy loam
	150-300	31.4	6.5	54.8	37.1	8.2	Gravelly sandy loam

^aCation exchange capacity, milliequivalents per 100 g soil.

^bTotal elemental carbon.

^cPercentages do not include objects larger than 2 mm (0.079 in.) in diameter (i.e., gravel).

rainfall within the continental United States varied from 4.4 to 5.5 in 1996 (NADP/NTN 1998). This may cause some concern that the rates of preservative release may have been higher if the study had been conducted in the northeastern United States, where rainfall is more acidic. However, past research indicated that pH of 4.0 or higher had no significant effect on leaching from CCA-C-treated wood. In one study, sulfuric acid and nitric acid buffers were used to study the effect of pH on CCA leaching from Western Hemlock blocks. The results showed 16% to 25% leaching of copper at pH 3, but 1% at pH 4. Leaching of arsenic was less affected by pH—generally around 2% to 3% at pH 4 and higher (Kim and Kim 1993). Cooper (1990) also pointed out that in acid rain situations or other cases where the volume of water is relatively low, wood has the capacity to buffer the acidity. He noted field observations where water dripping from treated wood is consistently 0.8 to 1.2 pH units higher than that of the rain.

Water

Water in the wetland ponds was evaluated for pH, alkalinity, conductivity, hardness, and dissolved organic content (Table I-4). Hardness, alkalinity, and conductivity are closely interdependent measures of water mineral content. All of these measurements were quite low in the wetland water. Hardness is a measure of dissolved calcium and magnesium in water. Wetland hardness was measured at slightly above 23 ppm at low water and as 15 ppm or lower during higher water. Water with a hardness below 75 ppm is typically considered to be soft; by comparison, the median hardness of the Mississippi River along its length varies from 140 to 420 ppm (Meade 1995). Alkalinity, a measure of the buffering capacity of water, was measured at approximately 20 ppm, which is at the lower end of the 10 to 500 ppm typical of fresh water. As expected for water with low levels of dissolved ions, conductivity of the water in the wetland was also minimal. These measurements all indicate that the

water in the wetland was very low in dissolved inorganic compounds. The general effect of the low mineral content of water is to greatly increase the bioavailability and toxicity of metal contaminants, although studies have also reported that inorganic ions can increase leaching from CCA-treated wood (Irvine and others 1972, Plackett 1984; Ruddick 1993). The pH of water in these ponds is nearly neutral (approximately 6.7), and the pH of naturally occurring fresh water ranges from around 4 in acid bogs to nearly 9 in hard water lakes. Past studies indicated that pH values above 4 have little effect on leaching of CCA-C components (Lebow 1996), although Warner and Solomon (1990) suggested that organic acids may promote leaching at higher pH levels.

Concentrations of dissolved organic carbon (DOC) in the wetland were also relatively low, with average values consistently below 1 ppm. Again, for comparison, median DOC levels in the Mississippi River vary from 3 to 12 ppm along its length (Meade 1995). A site with greater amounts of DOCs could have increased rates of release of preservative components from wood submerged in the wetland. Dissolved organic acids, at levels much higher than those that typically occur naturally, have been shown to increase the rate of CCA-C leaching (Cooper and Ung 1992b, Warner and Solomon 1990). In our study, however, the greater effect of the low DOC levels was probably to increase the bioavailability and toxicity of metals released into the water from the treated wood. There is a strong correlation between copper binding capacity and DOC in estuaries (Newell and Sanders 1986), and dissolved organic acids such as humic and fulvic acid appear to play a primary role in copper adsorption (Gieseking 1975, Stevenson and Fitch 1981, Tan 1993).

The fact that water at our test site was low in dissolved organic and inorganic constituents may lead to concerns that copper leaching or mobility would have been greater at a site with water richer in dissolved components. Although there may be some validity to this concern, the great majority of

Table I-4—Wetland water characteristics at test sites

Site	pH ^a	Alkalinity ^a (ppm)	Conductivity ^{a,b} (µs/cm)	DOC ^{a,c} (ppm)	Calcium (ppm) ^d		Magnesium (ppm) ^d		Hardness (ppm) ^d	
					Aug.	Nov.	Aug.	Nov.	Aug.	Nov.
ACQ-B	6.74	20	45	0.79	—	—	—	—	—	—
ACZA	6.73	18	43	0.72	6.1	4.0	2.0	1.3	23	15
CCA-C	6.79	23	53	0.84	5.4	3.9	1.8	1.3	21	15
Control	6.71	17	41	0.56	—	4.0	—	1.2	—	15

^aSamples collected March 1998.

^bConductivity, expressed as micromhos per centimeter.

^cDissolved organic carbon; average of three samples at each site.

^dCalcium, magnesium, and hardness values at low water (August 1996) and high water (November 1996).

treated wood in our study, and in most other applications, was exposed above the water and leaching was primarily caused by rainfall. Thus, overall leaching was probably not greatly affected by the characteristics of standing water at the site. In addition, the purity of the water does make the study a “worst case” from the viewpoint of copper toxicity. Copper is the most bioavailable, and thus the most toxic, when present in the free ionic form and not complexed with organic or inorganic components in water (Newell and Sanders 1986).

With the exception of water at the CDDC section, water movement was quite low in the areas immediately surrounding the test sections. The ACZA and ACQ-B sections were built into beaver ponds. Although water did move through the center of the ponds, no visible movement could be detected in attempts to measure flow immediately surrounding the ACQ-B and ACZA platforms. Very slight flow could be observed at the CCA-C platform during low water. As for the dissolved organic and inorganic components, the low flow rates at the test sections were expected to lessen the mobility of preservative components and cause them to concentrate in the sediment adjacent to the treated wood. Although preservative mobility may have been greater at a site with more water movement, the released preservative components would have been rapidly diluted to the point where they could not be differentiated from naturally occurring background levels. For this reason, sediment sampling and biological impact analysis were not conducted around the CDDC platform.

Levels of standing water at the sites within the wetland varied seasonally. Generally, water levels were highest during the May, June, and November inspections and lowest during the

August inspection. Water level fluctuation was greatest at the ACQ-B site and smallest at the ACZA site.

Preservative Treatments

Evaluation of wood preservative leaching is complicated by variability within the treated product. Leaching can be influenced by factors such as wood species, preservative retention, and post-treatment conditioning. Evaluation of the effects of these factors on preservative leaching from the boardwalk was beyond the scope of this study. Instead, we attempted to achieve conditions that would be representative of commercial treatment and reproducible.

The preservatives were applied to different wood species. The CCA-C and ACQ-B treatments were applied to Western Hemlock, ACZA to Douglas-fir, and CDDC to Southern Pine. With the exception of CDDC-Southern Pine, these preservative-wood species combinations are representative of the West Coast. CDDC is not yet widely used with western species. All Western Hemlock and Douglas-fir lumber was incised prior to treatment.

Preservative retentions for wood to be used in ground-contact applications were based on AWPA (1995) standards. Inspections of preservative retention and penetration were conducted by an independent inspection agency. Because preservative treatment of wood is not an exact science, actual retentions varied somewhat from target retentions (Table I-5).

Post-treatment conditioning (drying, steaming, and duration) may also affect leaching. The AWPA currently has no standards for post-treatment conditioning, but the Western Wood Preservers’ Institute (WWPI 1996) has developed best

Table I-5—Treatment data for wood incorporated in test sections^a

Preservative	Plant name and location	Charge no.	Date	Retention (kg/m ³ (lb/ft ³))	Penetration (failures) ^b	Post-treatment conditioning
ACQ-B	Conrad Wood Preserving, Northbend, Oregon	8654	12/4/95	7.04 (0.44)	0 of 20 (conforms)	Held over 3 weeks; surface appeared clean
ACQ-B	Conrad Wood Preserving, Northbend, Oregon	9048 (re-treat) ^c	12/17/95	8.16 (0.51)	4 of 20 (conforms)	Shipped before visual in- spection
ACZA	J.H. Baxter, Eugene, Oregon	84-0237	9/7/95	7.04 (0.44)	4 of 20 (conforms)	3-h in-retort ammonia re- moval, held over 1 week
CCA-C	Exterior Wood, Washougal, Washington	12168	9/21/95	11.68 (0.73)	2 of 20 (conforms)	Chromotropic acid test: lumber passed 10/17/95, timbers passed 4/23/96
CDDC	ISK Biosciences, Memphis, Tennessee	Lab charge	8/95	7.20 (0.45)	Not applicable	None specified

^aData for ACQ-B, ACZA, and CCA-C collected and supplied courtesy of Timber Products Inspection, Portland, Oregon.

^bTwenty-increment cores removed from each charge. A minimum of 16 cores must have penetration exceeding 10 mm (0.4 in.) to be considered in conformance. Penetration in the CDDC laboratory charge was visually evaluated by operators and judged to be satisfactory.

^cThis charge initially failed to meet the 6.4-kg/m³ (0.4-lb/ft³) retention requirement and the wood was subsequently re-treated.

management practices (BMPs) to address this issue (WWPI 1996). Accordingly, the CCA-C, ACQ-B, and ACZA material were specified to meet WWPI-recommended BMPs. One charge of ACQ-B material failed to meet the 6.4-kg/m^3 (0.4-lb/ft^3) retention specification and was subsequently re-treated. This charge was not inspected for BMP compliance. Because CDDC has not been widely used on the West Coast, BMPs were not available for this preservative.

Following treatment, all lumber was stored under cover at the treating plant until shipped to the test site. The ACZA- and CCA-C-treated material was transported to the test site in November 1995; the ACQ-B treated lumber in February 1996, and the CDDC-treated lumber in April 1996. At the test site, all lumber was stored under tarps until used in construction.

Prior to CCA-C treatment of Western Hemlock lumber, a brown pre-stain was applied to the lumber to enhance the appearance of the final product. This pre-stain is often used on the West Coast and in some other parts of the United States. However, the use of pre-stain raised concerns that it would affect the leaching characteristics of the preservative. To address this concern, a side-by-side laboratory comparison of leaching from pre-stained decking to leaching from decking that was not pre-stained was conducted (Lebow and Evans 1999). In brief, two end-matched specimens, 610 mm (24 in.) in length were cut from each of 10 Western Hemlock standard 38- by 140-mm (nominal 2- by 6-in.) boards. One specimen from each board was brushed with a pre-stain product identical to that applied to the boardwalk lumber. Both unstained and stained specimens were then pressure treated with a CCA-C solution to obtain a retention between 6.4 and 9.6 kg/m^3 (0.4 to 0.6 lb/ft^3). After a fixation and drying period, the specimens were exposed to artificial rainfall for 17 weeks. Rainfall drain-off was periodically collected from each specimen and analyzed for copper, chromium, and arsenic to compare leaching rates.

Boardwalk Design and Construction

The boardwalk design specified the use of large volumes of treated wood. Framing details for typical boardwalk sections and for the ACQ-B, ACZA, CCA-C, and CDDC viewing platforms are shown in Appendix IA. Photographs of portions of the test sections are shown in Part II of this report. In summary, for the elevated boardwalk, either standard 140- by 240-mm (nominal 6- by 10-in.) or standard 140- by 292-mm (nominal 6- by 12-in.) columns were used to support a pair of standard 89- by 292-mm (nominal 4- by 12-in.) joist headers. Five joists (standard 38- by 292-mm, nominal 2- by 12-in.) were run parallel to the boardwalk and attached to the joist headers using joist hangers. Decking (standard 38- by 140-mm, nominal 2- by 6-in.) was then fastened across the joists, perpendicular to the direction of the boardwalk. Handrails were constructed from standard 38- by 191-mm (nominal 2- by 8-in.) boards attached to the tops of the support

columns and to standard 140- by 140-mm (nominal 6- by 6-in.) support posts at midspan. In areas with firm footing, the support columns were set on 140- by 240- by 610-mm (5.5- by 9.5- by 24-in.) treated sill pads. Each boardwalk test section differed slightly in overall length and in the shape of the viewing platform. However, all test sections contained large volumes of treated wood, creating a realistic “worst case” leaching hazard.

In areas of soft sediment or where footing for the support posts was generally poor, a “pinned piling” foundation system was used to brace the support posts (App. IA, Fig. I-9). This support system consisted of two galvanized steel pipes 32 to 50 mm (1.25 to 2 in.) in diameter, which were placed in brackets attached to the posts and then driven until secure. Extra cross-bracing, consisting of standard 38- by 191-mm (nominal 2- by 8-in.) boards, was also used in these areas. Pinned piling and cross bracing were used in all areas where sediment samples were collected. Two concerns were raised about the use of galvanized material. First, concern was raised whether heavy galvanization would cause the release of zinc, which would harm aquatic organisms. To address this concern, sections of the galvanized piping were attached to the control platform. Second, concern was raised that the amount of zinc released from the ACZA-treated test section would be overestimated. To address this concern and to help quantify the contribution of galvanization to zinc release, zinc determinations were also made in the sediments surrounding the ACQ-B-treated wood.

In all cases, as much fabrication of the lumber as was practical was performed prior to treatment to minimize subsequent field modifications during construction. The boardwalk test sections were constructed by private contractors; provisions regarding field cuts and field treatments were specified in the contract. Most sawing and drilling was conducted on tarps away from the test areas. However, in some cases, such as bolt connections to support columns and cutting the columns to height, fabrication within the test site was necessary. In these cases, a combination of trays, tarps, and vacuum was used to collect the shavings and sawdust and minimize their contact with the water or soil at the test site. Little field treatment of cuts or drill holes was used in the test sections; a copper naphthenate solution (2% copper as metal) was used where treatment was deemed necessary.

Realistic “Worst Case” Conditions

The conditions at the site presented a severe leaching hazard. The high rate and consistency of rainfall was expected to induce more leaching here than in most other locations within the continental United States. The lack of movement in the wetland waters surrounding the treated wood was expected to minimize dilution of leached components. Similarly, the high cation exchange capacity of the soil allowed leached metals to accumulate to high concentrations immediately adjacent to the boardwalk. In addition, the large volume of wood used in

construction of the test sections provided an extensive surface area for leaching. Leaching from portions of wood submerged in standing water within the wetland may have been somewhat greater if the water had had a higher content of salts or dissolved organic acids. However, this same water purity would be expected to increase the bio-availability and toxicity of leached metals to aquatic insects, thus increasing the severity of biological impact.

The combination of high biological activity, high rainfall, moderate temperatures, stagnant water, and large volume of treated wood used in the boardwalk provided a realistic “worst case” scenario for the use of treated wood in sensitive environments. We anticipate that findings of leaching and biological impacts at this site will provide conservative estimates of potential impacts in most other applications.

Construction and Sampling Schedule

Construction of the boardwalk test sections was initiated in May 1996 (Table I-6). Just before construction began, samples were taken to obtain baseline counts of aquatic invertebrates and to determine background concentrations of copper, chromium, arsenic, and zinc. The ACQ-B and ACZA test sections were constructed first, followed by the CCA-C and CDDC sections. To use personnel and equipment efficiently, there was some overlap in construction of the test sections. The first postconstruction sampling was conducted after a minimum of 25 mm (1 in.) of rainfall had occurred. For subsequent sampling, all sites were inspected in a single

visit. The second postconstruction sampling (for preservative component concentrations only) was conducted in August 1996, the third postconstruction sampling in November 1996, and the 1-year sampling in May 1997.

Sampling and Analysis Protocol

General Procedures

The procedures used in this study were patterned after those described in documents by the Environmental Protection Agency (EPA 1982, 1995), American Society for Testing and Materials (ASTM 1983, 1989, 1991), and U.S. Fish and Wildlife Service (Brown and others 1993) and the *CRC Handbook of Techniques for Aquatic Sediments Sampling* (Mudroch and MacKnight 1991). Although none of these documents provides a detailed protocol for the exact sampling situation encountered in our study, the recommended methods of choosing sampling equipment, preventing sample contamination, establishing a chain of custody, and transporting and storing samples were followed as closely as possible.

All sample collection and analysis, other than that undertaken for biological impact assessment, was conducted by Forest Service personnel. For sampling purposes, each boardwalk test section (except CDDC) was divided into riparian and wetland zones. The riparian zone was defined as the area not routinely exposed to standing water during any season. The wetland zone was defined as that portion of the boardwalk that extended into standing water.

Table I-6—Sampling schedule and post-construction rainfall

Event	Period	Rainfall after construction	
		Time (months)	Accumulated rainfall (cm (in.))
Pre-construction sampling			
All sites	4/25/96–4/28/96	—	—
ACZA and ACQ-B construction	4/29/96–5/16/96	—	—
CCA-C and CDDC construction	5/17/96–6/10/96	—	—
Post-construction sampling^a			
ACZA and ACQ-B	5/23/96–5/25/96	0.3	13.5 (5.3)
	8/5/96–8/8/96	2.5	27.2 (10.7)
	11/14/96–11/17/96	6	83.1 (32.7)
	5/7/97–5/10/97 ^a	11.5	291.3 (114.7)
CCA-C and CDDC	6/19/96–6/21/96	0.5	2.0 (0.8)
	8/5/96–8/8/96	2	10.9 (4.3)
	11/14/96–11/17/96	5.5	66.8 (26.3)
	5/7/96–5/10/96 ^a	11	274.3 (108.0)

^aOne-year sampling.

Riparian Soil Sampling

Soil samples were removed to a depth of 305 mm (12 in.) with a 32-mm- (1.25-in.-) diameter stainless steel soil recovery probe. Before the probe was inserted, loose leaves or duff at the sampling location was brushed aside to reveal the topsoil. The core was removed from the probe in sections corresponding to depths of 0 to 152 mm (0 to 6 in.) and 152 to 305 mm (6 to 12 in.) from the soil surface and placed into pre-labeled polyethylene bags. After each sample was taken, loose soil on the probe was brushed into a bucket. The probe was then immersed in a second bucket containing a 5% nitric acid solution and thoroughly cleaned with a bottle brush. Finally, the probe was rinsed with deionized water, which was collected in a third bucket. Samples were refrigerated prior to shipping.

Wetland Sediment Sampling

Care was taken to minimize disturbance of sediments during sampling. Planks were suspended from the shoreline across fallen logs to allow access to the sampling areas without walking through the sediments. Sediment samples were collected in 406-mm- (16-in.-) long and 19-mm- (0.75-in.-) diameter acetate tubes. Prior to use, the tubes were rinsed in a 5% nitric acid solution and again with deionized water. To obtain samples, the caps were removed from each end of the tube and the tube was manually inserted into the sediment to a depth of at least 102 mm (4 in.). The cap was then replaced on the upper end of the tube to create a vacuum as the tube was removed from the sediment. The bottom cap was placed on the tube as it was withdrawn from the sediment. The filled tubes were stored upright in a freezer to prevent mixing during shipping. The frozen samples were packed into coolers with dry ice and shipped to the Forest Products Laboratory by air. The sediment cores were subsequently divided into two assay zones representing the areas 0 to 25 mm (0 to 1 in.) and 25 to 102 mm (1 to 4 in.) from the sediment surface. The sampling tubes were not reused.

Wetland Water Sampling

Water sampling procedures were modeled as closely as possible after methods recommended in the EPA *Handbook for Sampling and Sample Preservation of Water and Wastewater*, chapters 8, 15, and 17 (EPA 1982). Water samples were collected from the area of interest before disturbance by other sampling or inspection. Samples were collected manually, using a handmade dipper that consisted of a 500-mL wide-mouth polyethylene sample bottle attached to a wooden pole. Bottles used for water collection were purchased pre-cleaned to meet or exceed U.S. EPA inorganic analyte specifications. During sampling, bottles were slowly lowered into the water to sufficient depth to allow filling, with care taken to avoid contact with or disturbance of sediment. The sample bottle was then capped and a new bottle attached to the dipper for subsequent sampling. On the same day the water samples were taken, they were filtered through glass-fiber

filters and 2 mL of a 50% nitric acid solution was added to reduce the pH of the samples below 2 and stabilize the metals in solution. Water samples were refrigerated for storage and shipping. Results of water sampling are reported in Part II of this report, in conjunction with the analysis of effects of leaching on aquatic invertebrates.

Preconstruction Sampling Locations

After the trail had been cleared but before the test sections were constructed, preconstruction samples were taken to determine background levels of copper, chromium, arsenic, and zinc. These samples were taken from locations that matched the postconstruction sampling area as closely as possible, although the exact placement of the boardwalk was not known. A minimum of 16 soil locations and 10 sediment locations were sampled at the ACQ-B, ACZA, and CCA-C boardwalk sections before construction; 26 preconstruction soil samples were removed from the CDDC test section.

Postconstruction Sampling Locations

Soil Sampling—Soil samples were removed from the riparian area around the ACQ-B, ACZA, CCA-C, and CDDC boardwalk sections. Sampling transects, each 15 to 25 cm (6 to 9.9 in.) wide, were selected to minimize slope or other features that might direct rainfall run-off away from the sampling locations. Because movement of copper, chromium, arsenic, and zinc in soil is limited, we assumed that the transects were sufficiently separated to ensure that each transect allowed evaluation of leachate concentrations in a different portion of the boardwalk. At each inspection, soil samples were removed in four sampling locations within these transects, starting directly under the edge of the boardwalk and extending to 15, 30, and 60 cm (6, 12, and 24 in.) from the boardwalk. A sample was removed from the same sampling locations, within the width of the transect, at each of the four postconstruction inspections. Detail of a typical soil sampling scheme is shown in (Fig. I-2). The sampling transects were replicated 7 times for ACQ-B, ACZA, and CCA-C and 15 times for CDDC. In addition, four control samples were taken at a distance of at least 3 m (10 ft) from the boardwalk.

Sampling transects and an overview of test sections are shown in Appendix IB.

Sediment Sampling—Sediment samples were removed from the wetland area around the ACQ-B, ACZA, and CCA-C platforms or boardwalk sections. At each inspection, sediment samples were removed in 15- to 25-cm- (6- to 9.9-in.-) wide transects starting directly under the edge of the boardwalk, and extending to 30, 60, and 150 cm (12, 24, and 59 in.) from the boardwalk. A sample was removed from the same sampling locations, within the width of the transect, at each postconstruction inspection (Fig. I-3). Sampling transects were replicated seven times for ACQ-B and ACZA, and six times for CCA-C (App. IB). At the CCA-C site,

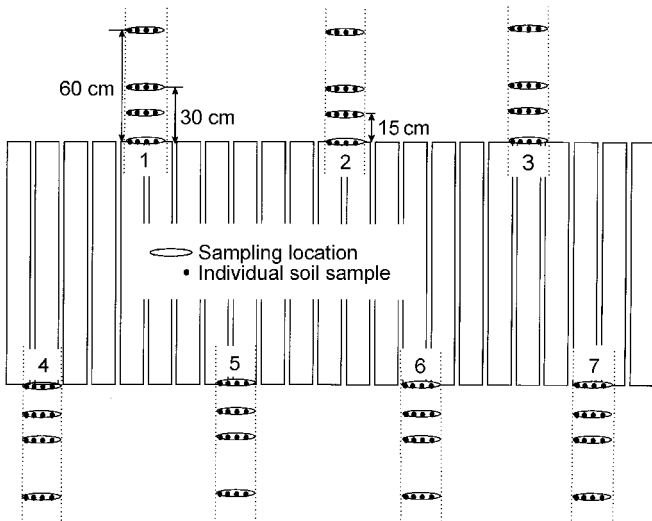

Figure I-2—Typical sampling scheme for soil areas. Samples were removed at 0, 15, 30, and 60 cm (0, 6, 12, and 24 in.) from the edge of the boardwalk in 7 to 15 replicated transects. The four dots in each sampling location represent samples removed at four time points after construction.

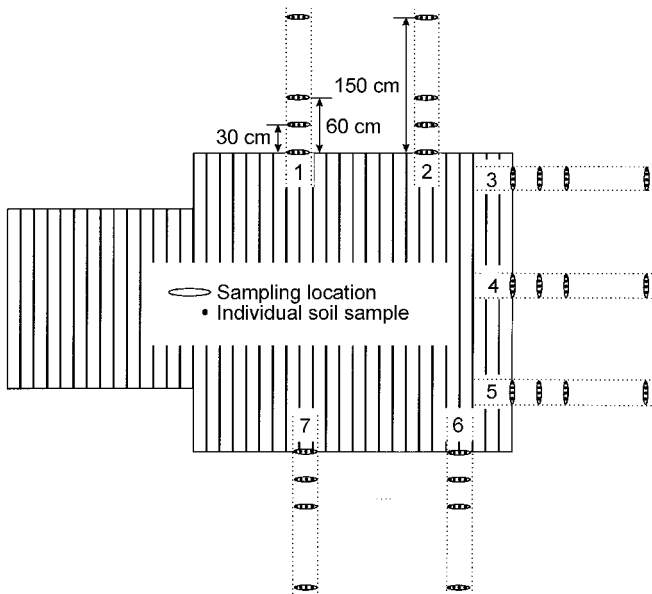

Figure I-3—Typical sampling scheme for sediment areas. Samples were removed at 0, 30, 60, and 150 cm (0, 12, 24, and 59 in.) from the edge of the boardwalk in seven replicated transects. The four dots in each sampling location represent samples removed at four time points after construction.

samples were also removed at 3 m (10 ft) downstream at two transects; during the final inspection (11 to 11.5 months after construction), sampling transects at all sites were expanded to include sample removal at 3m (10 ft) from the treated

wood. The walkway at the CCA-C site was also elevated to allow sampling directly under the walkway. A minimum of four control samples were also removed at a minimum distance of 10 m (33 ft) upstream from the boardwalk.

Water Sampling—Five water samples were collected from adjacent to the ACQ-B, ACZA, CCA-C, and control test sections during each postconstruction inspection. Samples were removed 10 m (33 ft) upstream and 0, 1, 3, and 10 m (0, 0.3, 10, and 33 ft) downstream from the boardwalk. Results of water sampling are reported in Part II of this report, in conjunction with the analysis of effects on aquatic invertebrates.

Quantification of Preservative Release

For the ACZA, CCA-C, and ACQ-B treated lumber, smaller specimens, 15 cm (6 in.) in length, were cut from the center of each of five surplus deck boards and end-sealed with an epoxy resin to retard end-grain leaching. The specimens were set into polyethylene containers above 19-L (5-gal) buckets so that all rainwater draining off the boards could be collected. The rainwater in the buckets was periodically analyzed for preservative components. Copper, chromium, and arsenic retention in the outer 1.5 cm (0.6 in.) of the upper, wide face of each deck board was determined by assaying end-matched specimens.

Determination of Sample Preservative Concentrations

Except for some modifications in extraction procedures (as described in the following text), EPA-recommended methods for laboratory determination of metal analytes were followed as closely as possible (EPA 1995). In all cases, appropriate laboratory standards and blanks were analyzed.

Soil samples were refrigerated until they could be air dried to a uniform moisture content in a room maintained at 27°C (80°F) and 30% relative humidity. The dried samples were then passed through a 2-mm (51-in.) screen and the larger material discarded. The remaining sample was ground using a ceramic mortar and pestle. Sediment samples were stored frozen. Frozen samples were sectioned into 0- to 25-mm (0- to 1-in.) and 25- to 102-mm (1- to 4-in.) depths from sediment surface. Samples were then weighed, thawed, allowed to air dry in a room maintained at 27°C (80°F) and 30% relative humidity, and re-weighed. The dried sediment samples were ground in the same way as were soil samples.

Approximately 1.5 kg (3.3 lb) of reference standard soil was prepared by combining portions of the preconstruction soil samples. To enhance homogeneity, this reference material was ground and sieved to obtain particle sizes between 0.075 and 0.175 mm (0.003 and 0.007 in.).

Ground soil and sediment samples were extracted using a microwave-assisted version of EPA Method 3050B, which is intended for determination of arsenic, chromium, copper, and zinc in sediments and soils (EPA 1995). Microwave-assisted extractions have been reported to be more reproducible than extractions by the conventional hot-plate method (Lorentzen and Kingston 1996). Approximately 1.5 g of sample, known to 0.01 g, was weighed into one of 12 Teflon pressure vessels and treated with 5.0 mL deionized water and 5.0 mL 70% nitric acid. At least one reference standard sample was included in each batch of 12 samples. The vessels were then sealed and placed into a CEM MD6–2000 Microwave Digester. The temperature in the vessel was increased from ambient to 150°C (302°F) during a 10-min ramping period and then held at 150°C (302°F) for 4.5 minutes. Pressure in the vessels reached a maximum of 345 to 620 kPa (50 to 90 lb/in²) during the holding period. Copper, chromium, and zinc concentrations in the resulting extract were determined by flame atomization atomic absorption spectroscopy, while graphite furnace atomization was used for arsenic analysis. Water samples were refrigerated and analyzed for preservative components using furnace atomization. Concentrations are reported in parts per million (ppm), which refers to micrograms per gram (µg/g) for soil and sediment samples or in parts per billion (ppb), which refers to micrograms per liter (µg/L) for water samples.

Analyses of the soil for properties such as pH, total carbon content, cation exchange capacity, component ratios, and textural classification were conducted at either the University of Wisconsin or Oregon State University Soil Testing laboratories. Analyses of sediment properties were conducted by Dr. Brooks and are reported in Part II of this report.

Assessment of Wood Preservative Efficacy

Many years are needed to fully evaluate the efficacy of preservative systems. The test sections are being evaluated annually for durability after 1, 2, and 5 years, and every third year thereafter until the structures are removed.

Wood Degradation

Resistance of the treated wood to biological attack and other structural degradation (surface appearance, checking, splitting, warping) is being assessed. The primary assessment is visual. The exterior surface is rated using the following scale: 10 is no degradation; 9, very light degradation; 7, moderate degradation; 4, heavy degradation; and 0, failure. In addition, at each inspection, soil is removed from around the ground-line of 10 sills or piling and the surface is examined for exterior soft rot. The extent of soft rot is rated with the same system used to rate extent of surface degradation.

Fastener Corrosion

In some cases, fastener corrosion can cause failure of a treated wood structure before the wood is degraded. The fasteners used in the construction of the test sections were electroplated or hot-dipped galvanized steel (stainless steel is very resistant to corrosion, but its cost is often prohibitive). Fasteners in each section were visually evaluated for surface appearance and rated by the scale described for surface and soft rot degradation.

In addition, a more controlled corrosion comparison was conducted for wood treated with CCA–C, ACZA, and ACQ–B and for untreated Douglas-fir using 10-mm- (3/8-in.-) diameter, 76-mm- (3-in.-) long bolts with accompanying washers and nuts. The stainless steel, hot-dipped galvanized, and electroplated bolts were weighed and their diameter measured in three places prior to installation. Excess deck boards with standard 38- by 140-mm dimensions (nominal 2- by 6-in. dimensions) were cut into 127-mm- (5-in.-) long specimens and air dried. One of each type of bolt was installed in decking specimens of each type of treated wood. Three holes were drilled, and one stainless steel, one hot-dipped galvanized, and one electroplated bolt were placed into each specimen. A washer was placed on the bolts on each face of the block to help trap moisture within the bolt hole. Ten replicate blocks of each type of treated wood were prepared. The specimens were then placed horizontally on a rack above ground so that the heads of the bolts were facing upwards. Five of these blocks were removed 12 months after installation, visually evaluated, brushed free of scale and rust, and their diameter measured. The remaining bolts will be evaluated 3 years after installation.

Statistical Analysis

Use of Geometric Mean

The concentrations of preservative components in soil and sediments can vary greatly, even at equivalent distances from the treated wood. While the concentrations of most observations remain relatively low, a few observations may have much higher levels of preservative components. In other words, the distributions of the concentrations of preservative components at any given distance from the wood are skewed, one of the defining characteristics of a lognormal distribution. Lognormal distributions are commonly assumed in environmental sampling. Ott (1995) discusses in detail the physical and stochastic reasons why lognormal populations naturally arise in environmental settings. Because of this skewness, traditional normality-based statistical methods directly applied to samples from a lognormal distribution are overly sensitive to outlying observations and lack power in comparing parts of the distribution where there is less information. If the lognormal distribution can be assumed, the normality-based methods can be applied to log transformed data, and the results are translated back to the original scale.

This back calculation results in what is referred to as the sample geometric mean, which is calculated as

$$GM = e^{\bar{y}}$$

where $\bar{y} = \frac{\sum \ln x_i}{n}$
 x_i = observed concentration

If concentrations of preservative components are lognormally distributed within a sampling area, the geometric mean of the samples is a better estimator than is the sample median of the median preservative concentration within that area. However, for small sample sizes that are highly skewed, this estimator has some associated positive bias (Gilbert 1987). Because small sample sizes made it difficult to definitively determine whether or not the underlying preservative concentrations were lognormally distributed in all cases, both the sample median and geometric mean are reported here.

Comparison to Preconstruction Levels

Geometric Means—The means of the log transformed values for samples collected at each distance from the boardwalk and each assay zone depth at each time point were compared to the means of the log transformed values for the appropriate preconstruction and control samples using analysis of variance (ANOVA). Bonferroni-adjusted probability values were used in mean comparisons to maintain a component by depth family-wise error rate of no more than $\alpha = 0.05$.

Median Values—The median values for samples collected at each distance from the boardwalk and each assay zone depth at each time point were compared to the median values for the appropriate preconstruction and control samples by rank transforming the data and performing ANOVA. Bonferroni-adjusted probability values were used in median comparisons.

Individual Samples—Ninety-five percent one-sided upper tolerance bounds were calculated on the 95th percentile of a lognormal distribution for the preconstruction soil and sediment samples. Any postconstruction sample that exceeded this upper bound was considered to be elevated.

CCA Studies

Background CCA Levels

At the site of the CCA-C section, background levels of copper varied from 20 to 43 ppm in soil, varied from 17 to 24 ppm in sediment, and were below 2 ppb in wetland water. Background levels of chromium varied from 6 to 8 ppm in soil, varied from 7 to 14 ppm in sediment, and were below 2 ppb in wetland water. Background levels of arsenic ranged from 1 to 3 ppm in soil, ranged from 1 to 4 ppm in sediment, and were below 1 ppm in wetland water.

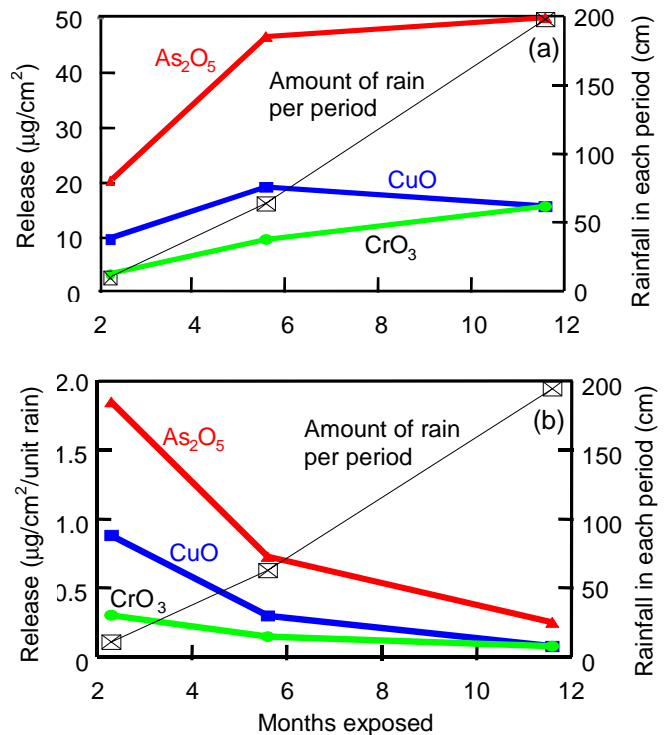

Figure I-4—Release of copper, chromium, and arsenic into rainwater collected from CCA-C-treated decking. Rate of release expressed as (a) $\mu\text{g}/\text{cm}^2$ and (b) $\mu\text{g}/\text{cm}^3/\text{unit rain}$. 1 unit = 2.54 cm (1 in.).

Rate of CCA Release in Rainfall

Collection and analysis of rainfall from five CCA-C-treated deck boards revealed that the greatest total release of chromium, copper, and arsenic occurred between the 2- and 5.5-month inspections and between the 5.5- and 11-month inspections (Fig. I-4a). The total release of copper appeared to be slightly higher between the 2- and 5.5-month sampling points, whereas the total release of arsenic and chromium was highest during the last exposure period. If viewed as a function of rainfall, however, the rate of leaching was apparently highest during the initial exposure period and then declined during the next two exposure periods (Fig. I-4b). The amount of arsenic released was greater than that of copper or chromium at each sampling point. This is not always typical; in some cases copper has been reported to be the most leachable of CCA-C components (Lebow 1996). As expected, release of chromium was lower than that of the other CCA-C components, although release of copper did decline to a similar level at the 11-month sampling point.

The pre-exposure retention of CCA-C components in the outer 1.5-cm (0.6-in.) of the upper, wide face of the decking was determined by assaying end-matched samples cut from adjacent to the exposure specimens. The average retention was 1.31 kg/m^3 (0.08 lb/ft^3) for chromium trioxide, 0.69 kg/m^3 (0.04 lb/ft^3) for copper oxide, and 0.99 kg/m^3

(0.06 lb/ft³) for arsenic pentoxide, yielding a total CCA–C retention of 2.99 kg/m³ (0.19 lb/ft³). This retention is below the target retention of 6.4 kg/m³ (0.4 lb/ft³), possibly because these boards were sampled on the wide faces, whereas samples for determining charge retention were removed from the narrow faces of select boards in a charge.

Because the retention in the five deck boards selected for rainwater collection was substandard and differed greatly from the charge retention (Table I–5), a more intensive sampling and analysis of boardwalk CCA–C retention was conducted. Fifty-five samples were removed from the narrow faces of joists, joist headers, columns, and railing. This analysis revealed that the average CCA–C retention in the outer 15-mm (0.6-in.) varied from 7.7 kg/m³ (0.48 lb/ft³) in the joist headers to 16.3 kg/m³ (1.02 lb/ft³) in the columns. The overall average CCA–C retention in the samples was 10.6 kg/m³ (0.66 lb/ft³), a value well above the target retention of 6.4 kg/m³ (0.4 lb/ft³) and in close agreement with the charges reported (Table I–5). It is evident that the five deck boards were under-treated relative to the charge as a whole and the results may underestimate the quantity of preservative released. However, the pattern of release rate from these deck boards (that is, the most rapid leaching occurred early in the study) is probably reflective of the boardwalk as a whole.

Accumulation and Mobility of CCA in Soil

Two assay zones were used for soil samples. The upper zone was 0 to 15 cm (0 to 6 in.) and the lower zone 15 to 30 cm (6 to 12 in.). Concentrations of CCA–C components in individual soil samples are shown in Appendix IC.

Copper

Copper concentrations in the soil adjacent to the CCA–C-treated viewing platform generally remained low throughout the course of the study, although a few samples had elevated levels in the upper assay zone. After 2 months, only one sample at the edge of the boardwalk had a very slightly elevated level of copper (32 ppm). The median and geometric mean were also elevated at this distance, but this appeared to be primarily a function of the low variability within the background samples (Table I–7, App. IC). Slightly elevated (34 ppm) copper was also detected in one sample under the edge of the boardwalk at the 5.5-month inspection. At the 11-month sampling, a maximum of 56 ppm copper was detected immediately adjacent to the viewing platform. One sample with slightly elevated (38 ppm) copper was also detected 15 cm (6 in.) from the boardwalk. The median and geometric mean copper concentrations were slightly elevated under the edge of the boardwalk. In general, copper levels in the lower assay zone were not affected by proximity to the CCA–C treated wood. However, one sample removed from

immediately adjacent to the boardwalk at the 11-month inspection did contain 37 ppm copper.

Chromium

Chromium levels in the soil adjacent to the CCA–C-treated viewing platform were generally not elevated. In the upper assay zone, no elevated levels were detected until 11 months after construction; at that time, four samples had very slightly elevated chromium levels (Table I–8, App. IC). These samples were scattered over the sampling area, and they did not reflect the expected leaching pattern. One sample also contained a very slightly elevated chromium concentration (16 ppm) in the lower assay zone. Chromium release from CCA–C-treated wood is generally lower than that of copper or arsenic, and the rate of release from the platform was apparently not great enough to allow significant accumulation in the soil. Chromium movement in soil is generally limited because chromium reacts strongly with soil components. Thus, it is unlikely that chromium leached into the soil is being diluted below detectable levels.

Arsenic

Elevated levels of arsenic were not detected in individual samples removed from under the CCA–C-treated platform at either 2 weeks or 2 months after construction, although the geometric mean and median levels immediately under the edge of the boardwalk were slightly elevated after 2 weeks (Table I–9, App. IC). Elevated levels of arsenic were detected in the upper 15-cm (6-in.) of several samples removed immediately adjacent to the boardwalk at the 5.5-month inspection. This delayed effect may have been due to the rainfall pattern in the area; large amounts of rain fell after the 2-month inspection (Table I–6). At the 5.5-month inspection, a maximum level of 36 ppm arsenic was detected at the edge of the boardwalk (dripline), and the median and geometric mean were slightly elevated (Table I–9). Little elevation was detected at 15 cm (6 in.) from the boardwalk or in the lower assay zone of the samples. At 11 months after construction, a maximum of 29-ppm arsenic was detected in the top 15-cm (6-in.) of soil at the boardwalk dripline, and the median concentration detected at this distance increased to 15 ppm. In addition, 14 ppm arsenic was detected in the upper 15-cm (6-in.) of a sample removed at 15 cm (6 in.) from the boardwalk, and a maximum of 16 ppm arsenic was found in the lower assay zone of a sample removed at the boardwalk dripline.

Apparently, arsenic released from the treated wood is slowly concentrating directly under the edge of the boardwalk and migrating slight distances down and away through the soil. However, as noted in Figure I–4, arsenic leaching has stabilized, and further accumulation should progress more slowly. The soil at the test site is classified as sandy loam, with approximately 70% sand, 20% silt, and 6% to 7% clay.

Table I-7—CCA-C: Copper concentrations in soil samples^a

Time of sampling	Distance from boardwalk ^b (cm (in.))	Sample size	Range (ppm)	Median (ppm)	Mean (ppm)	Geometric mean (ppm)
Upper 15 cm (6 in.) of soil						
Preconstruction	Intended path	16	20–24	22	22	22
0.5 months	0 (0)	7	21–23	23	22	22
	15 (6)	7	17–25	23	22	22
	30 (12)	7	19–27	22	22	22
	60 (24)	7	19–24	21	21	21
	Control	4	23–24	23	23	23
2 months	0 (0)	7	24–32	<u>25</u>	26	<u>26</u>
	15 (6)	7	19–24	23	23	22
	30 (12)	7	20–27	22	23	23
	60 (24)	7	21–25	22	23	23
	Control	4	20–24	22	22	22
5.5 months	0 (0)	7	20–34	26	26	26
	15 (6)	7	17–25	21	21	21
	30 (12)	7	18–22	21	21	21
	60 (24)	7	18–23	21	20	20
	Control	4	17–22	19	20	19
11 months	0 (0)	7	21–56	<u>28</u>	33	<u>31</u>
	15 (6)	7	19–38	23	26	25
	30 (12)	7	18–29	23	23	23
	60 (24)	7	19–24	21	21	21
	Control	4	18–22	20	20	20
Lower 15–30 cm (6–12 in.) of soil						
Preconstruction	Intended path	15	22–43	24	26	26
0.5 months	0 (0)	7	18–28	21	22	22
	15 (6)	7	20–25	23	23	23
	30 (12)	7	20–24	22	22	22
	60 (24)	7	21–25	23	23	23
	Control	2	21–21	21	21	21
2 months	0 (0)	7	17–25	23	22	22
	15 (6)	7	20–27	24	24	24
	30 (12)	5	21–24	23	23	23
	60 (24)	7	20–24	23	22	22
	Control	2	22–23	23	23	23
5.5 months	0 (0)	7	21–29	25	24	24
	15 (6)	7	20–23	23	25	25
	30 (12)	7	19–25	21	22	22
	60 (24)	7	22–26	23	22	22
	Control	2	23–24	24	24	24
11 months	0 (0)	7	20–37	26	26	26
	15 (6)	7	21–29	24	25	24
	30 (12)	6	20–24	23	23	23
	60 (24)	6	21–24	22	22	22
	Control	1	21	21	21	21

^aUnderlined median and geometric mean values are elevated above background and control levels based on 95% tolerance interval.

^b0 = dripline.

Table I-8—CCA-C: Chromium concentrations in soil samples^a

Time of sampling	Distance from boardwalk ^b (cm (in.))	Sample size	Range (ppm)	Median (ppm)	Mean (ppm)	Geometric mean (ppm)
Upper 15 cm (6 in.) of soil						
Preconstruction	Intended path	16	7–8	7	7	7
0.5 months	0 (0)	7	7–8	7	7	7
	15 (6)	7	7–9	8	8	8
	30 (12)	7	7–9	8	8	8
	60 (24)	7	6–8	8	7	7
	Control	4	7–10	8	9	8
2 months	0 (0)	7	8–9	9	9	9
	15 (6)	7	7–8	8	8	8
	30 (12)	7	8–10	8	9	9
	60 (24)	7	8–10	8	9	9
	Control	4	8–9	8	8	8
5.5 months	0 (0)	7	7–11	8	9	9
	15 (6)	7	7–10	8	8	8
	30 (12)	7	7–13	<u>10</u>	10	<u>10</u>
	60 (24)	7	7–10	8	8	8
	Control	4	6–9	8	8	8
11 months	0 (0)	7	8–13	9	10	10
	15 (6)	7	6–12	8	9	8
	30 (12)	7	9–20	<u>11</u>	13	<u>13</u>
	60 (24)	7	7–12	10	10	10
	Control	4	6–10	10	8	8
Lower 15–30 cm (6–12 in.) of soil						
Preconstruction	Intended path	15	6–8	7	7	7
0.5 months	0 (0)	7	6–10	7	7	7
	15 (6)	7	3–16	9	10	9
	30 (12)	7	9–14	12	12	12
	60 (24)	7	9–13	11	11	11
	Control	2	8–10	9	9	9
2 months	0 (0)	7	10–13	11	11	<u>11</u>
	15 (6)	7	9–13	12	11	11
	30 (12)	5	10–13	12	12	<u>12</u>
	60 (24)	7	8–12	11	11	11
	Control	2	11–11	11	11	11
5.5 months	0 (0)	7	6–10	7	8	8
	15 (6)	7	6–9	8	7	7
	30 (12)	7	4–8	7	6	6
	60 (24)	7	6–9	8	8	8
	Control	2	8–9	8	8	8
11 months	0 (0)	7	7–11	9	9	9
	15 (6)	7	8–10	9	9	9
	30 (12)	6	9–13	11	11	11
	60 (24)	6	7–10	9	9	9
	Control	1	9–9	9	9	9

^aUnderlined median and geometric mean values are elevated above background and control levels based on 95% tolerance interval.

^b0 = dripline.

Table I-9—CCA-C: Arsenic concentrations in soil samples^a

Time of sampling	Distance from boardwalk ^b (cm (in.))	Sample size	Range (ppm)	Median (ppm)	Mean (ppm)	Geometric mean (ppm)
Upper 15 cm (6 in.) of soil						
Preconstruction	Intended path	16	1-3	3	2	2
0.5 months	0 (0)	7	3-6	<u>5</u>	4	<u>4</u>
	15 (6)	7	1-2	1	1	1
	30 (12)	7	1-2	1	1	1
	60 (24)	7	1-1	1	1	1
	Control	4	1-2	1	1	1
2 months	0 (0)	7	1-6	3	2	2
	15 (6)	7	1-5	2	2	2
	30 (12)	7	1-4	2	2	2
	60 (24)	7	1-2	1	1	1
	Control	4	1-1	1	1	1
5.5 months	0 (0)	7	2-36	<u>6</u>	10	<u>7</u>
	15 (6)	7	1-7	2	3	2
	30 (12)	7	1-3	3	2	2
	60 (24)	7	1-3	1	1	1
	Control	4	1-3	1	1	1
11 months	0 (0)	7	5-29	<u>15</u>	15	<u>12</u>
	15 (6)	7	3-14	7	8	7
	30 (12)	5	2-7	5	4	4
	60 (24)	7	2-5	4	4	3
	Control	4	2-3	2	2	2
Lower 15-30 cm (6-12 in.) of soil						
Preconstruction	Intended path	15	1-3	2	2	2
0.5 months	0 (0)	7	2-3	2	2	2
	15 (6)	7	3-6	4	4	3
	30 (12)	7	3-3	3	3	3
	60 (24)	7	1-7	3	3	3
	Control	2	3-4	3	3	3
2 months	0 (0)	7	3-6	4	4	4
	15 (6)	7	3-6	4	5	4
	30 (12)	5	3-5	4	4	4
	60 (24)	7	3-4	3	3	3
	Control	2	3-4	4	4	3
5.5 months	0 (0)	6	2-4	3	3	3
	15 (6)	7	2-3	2	2	2
	30 (12)	7	2-3	2	2	2
	60 (24)	7	2-3	2	2	2
	Control	2	3-3	3	3	3
11 months	0 (0)	7	2-16	3	6	4
	15 (6)	7	2-4	3	3	3
	30 (12)	6	4-6	5	5	5
	60 (24)	6	2-4	3	3	3
	Control	1	2-2	2	2	2

^aUnderlined median and geometric mean values are elevated above background and control levels based on 95% tolerance interval.

^b0 = dripline.

Based on previous studies, the sandy nature of the soil at this site should have allowed leached CCA–C components to be relatively mobile, although the relatively high cation exchange capacity (24 to 30 meq) may retard movement of copper and chromium. Despite this, arsenic movement in soil appears to be confined to within 60 cm (24 in.) of the treated wood.

Accumulation and Mobility of CCA in Sediment

Because the section of boardwalk evaluated for sediment CCA–C concentrations was elevated above the wetland, it was possible to remove samples from directly underneath the walkway, between the support columns. In the following discussion, these samples are referred to as being removed from “under” the boardwalk. As for the soil samples, sediment samples were removed from the under the edge of the boardwalk, directly below the end of the decking. These samples are referred to as being removed at “zero distance” from the boardwalk. The assay zones for the sediment samples were 0 to 2.5 cm (0 to 1 in.) (upper zone) and 2.5 to 10 cm (1 to 4 in.) (lower zone). Concentrations of CCA–C components in individual sediment samples are shown in Appendix IC.

Copper

Two weeks after construction, elevated copper levels were detected in the top 2.5 cm (1 in.) of sediment associated with the CCA–C treated walkway (App. IC). Maximum concentrations of 49, 48, 43 and 48 ppm were detected at 0, 30, and 60 cm (0, 12, and 24 in.) downstream and under the boardwalk (Table I–10). Median and geometric mean copper levels were slightly elevated under the boardwalk in this upper assay zone (Table I–10). In addition, one sample at zero distance from the boardwalk contained 55 ppm copper and one sample at 30 cm (12 in.) from the boardwalk contained 35 ppm copper in the lower assay zone (Table I–10, App. IC).

Two months after construction, copper concentrations in samples removed from under the boardwalk were substantially increased. The maximum concentration detected in the upper assay zone under the boardwalk was 201 ppm and the median concentration 64 ppm. Copper levels were also increased in the lower assay zone; the maximum concentration was 121 ppm and the median concentration 92 ppm. Increases were not as dramatic in samples removed in other locations, although the median concentration detected at zero distance downstream was increased to 42 ppm in the upper assay zone. A maximum of 79 ppm copper was detected in the lower-zone segment of a sample removed at zero distance downstream from the boardwalk.

At 5.5 months after construction, copper levels in the upper assay zone showed further increases under the boardwalk and

at zero distance downstream. The maximum level detected under the boardwalk was only slightly increased, but the median level had increased from 65 to 112 ppm. The maximum copper concentration detected at zero distance downstream from the boardwalk had increased to 138 ppm, and the median level detected at this distance had increased to 67 ppm. Maximum levels detected in the upper assay zone appeared to have increased only slightly at greater distances from the boardwalk.

In contrast to copper levels in the upper 2.5 cm (1 in.) of sediment, copper levels detected in the lower assay zone appeared to decline between 2 and 5.5 months. Only three samples had elevated copper concentrations; two of these samples were removed from directly under the boardwalk. It is unclear why copper levels in the lower assay zone had decreased, while copper levels in the sediments immediately above this zone had increased. A similar trend was noted for chromium and arsenic concentrations in the lower sediment assay zone.

The 11-month sampling revealed a decline or stabilization of copper concentrations under the boardwalk and at zero distance downstream, but a slight increase in median copper levels 30 and 60 cm (1 and 2 ft) downstream. This suggests that release from the boardwalk had slowed, but copper was continuing to be redistributed to greater distances from the treated wood. Slightly elevated levels of copper were detected as far as 3 m (10 ft) downstream from the boardwalk in the upper 2.5-cm (1-in.) of sediment. During the three previous postconstruction inspections, elevated copper levels had not been detected more than 60 cm (2 ft) downstream from the walkway. Copper levels appeared to increase slightly in the lower assay zone, but were still below levels detected 2 months after construction.

Copper deposited in the sediments is likely to continue to redistribute gradually over time. Adsorption reactions with inorganic and organic compounds in water and sediments greatly affect the solubility and mobility of copper. The quantity of fine sediments at the site, as well as the localized pattern of copper distribution, suggests that the majority of copper released from the wood rapidly becomes associated with sedimentary material. Further mobility is likely to occur primarily when the sediments themselves are dislodged by high water or other types of disturbances.

Chromium

Elevated chromium levels were detected in the sediments 2 weeks after construction. In the top 2.5 cm (1 in.) of sediment, a maximum of 23 ppm chromium was detected in samples removed from directly under the boardwalk, while samples removed at zero distance and 60 cm (2 ft) downstream from the boardwalk had maximum concentrations of 37 and 27 ppm, respectively (Table I–11, App. IC).

Table I-10—CCA-C: Copper concentrations in sediment samples^a

Time of sampling	Distance from boardwalk ^b (cm (in.))	Sample size	Range (ppm)	Median (ppm)	Mean (ppm)	Geometric mean (ppm)
Upper 2.5 cm (1 in.) of sediment						
Preconstruction	Intended path	9	19–24	22	22	22
	Under	6	28–49	<u>33</u>	35	<u>34</u>
0.5 months	0 (0)	6	25–48	31	34	33
	30 (12)	6	18–43	26	28	27
	60 (24)	6	21–48	31	32	31
	150 (59)	6	14–34	23	23	22
	300 (118)	2	27–28	28	28	28
	Control	4	19–29	23	23	23
	2 months	Under	6	45–201	<u>64</u>	85
0 (0)		6	36–55	<u>42</u>	43	<u>43</u>
30 (12)		6	24–54	35	36	35
60 (24)		6	24–48	29	32	31
150 (59)		6	17–32	24	25	24
300 (118)		2	22–35	29	29	28
Control		4	21–26	24	24	24
5.5 months	Under	6	35–219	<u>112</u>	116	<u>98</u>
	0 (0)	6	21–138	<u>67</u>	72	<u>58</u>
	30 (12)	6	20–64	<u>38</u>	43	<u>40</u>
	60 (24)	6	21–59	28	32	30
	150 (59)	6	21–28	22	23	23
	300 (118)	2	22–27	25	25	25
	Control	4	15–23	22	20	20
11 months	Under	6	34–115	<u>85</u>	80	<u>73</u>
	0 (0)	6	39–95	<u>66</u>	67	<u>63</u>
	30 (12)	6	32–83	<u>61</u>	59	<u>57</u>
	60 (24)	6	26–61	<u>51</u>	46	<u>44</u>
	150 (59)	6	19–51	32	35	33
	300 (118)	6	23–38	29	30	30
	Control	10	18–60	29	33	31
Lower 2.5–10 cm (1–4 in.) of sediment						
Preconstruction	Intended path	9	17–21	19	19	19
	Under	6	21–29	24	24	24
0.5 months	0 (0)	6	17–55	24	29	27
	30 (12)	6	18–35	22	24	23
	60 (24)	6	17–34	24	24	24
	150 (59)	6	16–24	21	20	20
	300 (118)	2	14–17	16	16	16
	Control	4	20–25	22	22	22
	2 months	Under	5	22–121	<u>92</u>	84
0 (0)		6	20–79	<u>34</u>	40	<u>36</u>
30 (12)		6	22–53	28	32	30
60 (24)		6	21–24	22	22	22
150 (59)		6	17–22	18	19	19
300 (118)		2	20–23	22	22	21
Control		4	14–22	21	20	19
5.5 months	Under	6	20–59	28	33	31
	0 (0)	6	20–29	22	23	23
	30 (12)	5	17–36	20	23	22
	60 (24)	6	15–26	19	20	19
	150 (59)	6	13–23	18	18	18
	300 (118)	2	19–24	22	21	21
	Control	3	13–21	21	19	18
11 months	Under	6	23–46	31	32	<u>31</u>
	0 (0)	6	20–45	29	29	28
	30 (12)	6	21–83	25	35	30
	60 (24)	6	20–34	25	26	25
	150 (59)	6	14–22	18	18	18
	300 (118)	6	21–26	21	22	22
	Control	10	16–37	24	24	24

^aUnderlined median and geometric mean values are elevated above background and control levels based on 95% tolerance interval.

^b0 = edge.

Table I-11—CCA-C: Chromium concentrations in sediment samples^a

Time of sampling	Distance from boardwalk ^b (cm (in.))	Sample size	Range (ppm)	Median (ppm)	Mean (ppm)	Geometric mean (ppm)	
Upper 2.5 cm (1 in.) of sediment							
Preconstruction	Intended path	9	9–14	11	11	11	
	Under	6	9–23	14	15	14	
0.5 months	0 (0)	6	9–37	15	21	18	
	30 (12)	6	8–21	12	14	13	
	60 (24)	6	9–27	16	17	16	
	150 (59)	6	8–17	10	11	10	
	300 (118)	2	12–12	12	12	12	
	Control	4	9–12	10	10	10	
	2 months	Under	6	19–104	<u>27</u>	39	<u>33</u>
		0 (0)	6	17–33	<u>20</u>	22	<u>21</u>
		30 (12)	6	9–38	17	19	17
		60 (24)	6	10–29	13	16	15
150 (59)		6	7–17	14	13	13	
300 (118)		2	12–14	13	13	13	
Control		4	9–11	10	10	10	
5.5 months		Under	6	15–55	<u>26</u>	29	<u>27</u>
		0 (0)	6	9–38	17	22	<u>19</u>
		30 (12)	6	9–30	17	17	16
	60 (24)	6	7–23	14	14	13	
	150 (59)	6	8–13	11	10	10	
	300 (118)	2	10–15	12	12	12	
	Control	4	6–12	10	9	9	
	11 months	Under	6	14–37	<u>20</u>	23	<u>21</u>
		0 (0)	6	10–32	14	19	17
		30 (12)	6	7–40	21	21	18
60 (24)		6	5–24	15	15	14	
150 (59)		6	7–14	12	11	11	
300 (118)		6	12–18	13	14	14	
Control		10	6–11	9	9	9	
Lower 2.5–10 cm (1–4 in.) of sediment							
Preconstruction		Intended path	9	7–8	7	7	7
		Under	6	8–14	8	10	10
0.5 months	0 (0)	6	7–35	10	14	12	
	30 (12)	6	7–17	9	11	10	
	60 (24)	6	7–16	9	10	9	
	150 (59)	6	6–10	7	7	7	
	300 (118)	2	5–7	6	6	6	
	Control	4	9–10	9	10	9	
	2 months	Under	5	8–36	<u>23</u>	23	<u>20</u>
		0 (0)	6	6–41	14	16	13
		30 (12)	6	8–37	11	15	12
		60 (24)	6	6–12	9	9	8
150 (59)		6	5–10	7	7	7	
300 (118)		2	7–7	7	7	7	
Control		4	7–9	7	8	8	
5.5 months		Under	6	8–11	10	10	10
		0 (0)	6	7–10	9	9	9
		30 (12)	5	6–11	7	8	8
	60 (24)	6	6–8	8	8	7	
	150 (59)	6	4–11	7	7	7	
	300 (118)	2	7–10	9	9	8	
	Control	3	6–10	9	8	8	
	11 months	Under	6	6–14	9	10	9
		0 (0)	6	6–18	7	9	8
		30 (12)	6	6–19	7	9	8
60 (24)		6	4–10	8	7	7	
150 (59)		6	2–9	7	6	6	
300 (118)		6	6–10	7	7	7	
Control		10	4–12	9	9	8	

^aUnderlined median and geometric mean values are elevated above background and control levels based on 95% tolerance interval.

^b0 = edge.

A few samples also contained elevated chromium concentrations in the lower assay zone. In one sample removed at zero distance downstream from the boardwalk, the chromium level was elevated to 35 ppm.

At the 2-month inspection, chromium concentrations in the top 2.5 cm (1 in.) of sediment under the boardwalk were increased to a maximum concentration of 104 ppm and a median level of 27 ppm. The median chromium level was also increased slightly in samples removed at zero distance downstream from the boardwalk, as were the maximum levels detected at 30 and 60 cm (1 and 2 ft) downstream. In the lower assay zone, maximum chromium levels were increased under the boardwalk and at 0 and 30 cm (0 and 1 ft) downstream. The median and geometric mean chromium levels in the lower assay zone were increased to 23 and 20 ppm, respectively, in samples removed from directly under the boardwalk (Table I-11).

Chromium levels detected in the sediments were generally stabilized or had declined at 5.5 months after inspection. Median levels in the top 2.5 cm (1 in.) of sediment remained relatively constant, but the maximum level detected under the boardwalk had declined to 55 ppm. Concentrations of chromium declined more steeply in the lower assay zone of the sediment samples, dropping to background levels in all samples.

By 11 months after construction, maximum, median, and geometric mean chromium levels in the top 2.5 cm (1 in.) of sediment had continued to decline under the boardwalk and at zero distance downstream, while levels at 30 and 60 cm (1 and 2 ft) downstream appeared to have increased slightly. Elevated chromium levels were also detected in two samples removed 3 m (10 ft) downstream. This is similar to the trend observed for copper at the 11-month inspection and again suggests that release of chromium from the boardwalk had diminished, but redistribution of sediment further downstream was continuing. As observed at the 5.5-month inspection, little elevation was detected in any samples in the lower assay zone.

During the course of this study, elevated levels of chromium were detected as far as 3 m (10 ft) from the boardwalk, but samples with elevated levels were generally confined to within 60 cm (2 ft) of the walkway. The geometric mean and median chromium concentrations were elevated only under the boardwalk and at zero distance downstream. Like copper, chromium tends to be associated with sediment fines, and thus it might be more concentrated in areas where sediment fines are deposited by the current. Chromium movement away from the boardwalk is likely to be associated with suspended sediment.

Arsenic

Two weeks after construction, elevated levels of arsenic were found in samples removed from the top 2.5 cm (1 in.) of sediment under the boardwalk and at all distances downstream from the boardwalk (Table I-12, App. IC). The highest level was 32 ppm, detected in a sample removed at zero distance downstream from the boardwalk. Median and geometric mean arsenic levels in the upper 2.5 cm (1 in.) of sediment were elevated under the boardwalk and at 0 and 60 cm (0 and 2 ft) downstream (App. IC). Elevated levels in the lower assay zone were found in samples under the boardwalk and 0, 30, and 60 cm (0, 1, and 2 ft) downstream, with a maximum of 43 ppm detected at 0 cm (0 ft) downstream (Table I-12, App. IC). However, median and geometric mean copper levels were not elevated at any distance from the boardwalk.

At the 2-month inspection, elevated arsenic levels in the top 2.5 cm (1 in.) of sediment were again found under the boardwalk and at all distances downstream from the boardwalk. The maximum concentration (130 ppm) was detected in a sample removed from under the boardwalk; the median and geometric mean concentrations in this area had increased from 34 to 41 ppm, respectively. Median arsenic concentrations had also increased in the top 2.5 cm (1 in.) of sediment at 0 and 30 cm (0 and 1 ft) downstream from the boardwalk. Arsenic concentration in the lower assay zone had also increased markedly directly under the boardwalk; the median level in this zone had increased from 3 to 46 ppm. Maximum levels detected at 0 and 30 cm (0 and 1 ft) downstream from the boardwalk were similar to those found in the upper assay zone, but median levels were lower in the lower assay zone.

The third postconstruction inspection, at 5.5 months, revealed that median arsenic levels in the top 2.5 cm (1 in.) of sediment were continuing to increase under the boardwalk and at zero distance downstream. Levels remained fairly constant at greater distances downstream. Median and geometric mean arsenic levels were elevated at each distance from the boardwalk, except for 1.5 m (5 ft) downstream. The maximum concentration detected had decreased from 130 to 82 ppm directly under the boardwalk, but had increased from 34 to 88 ppm at zero distance downstream from the boardwalk.

Arsenic concentrations in the lower assay zone declined substantially between the 2- and 5.5-month inspections, a trend that was also noted for copper and chromium. Elevated arsenic levels were detected in only a few samples, and the maximum concentration detected was only 10 ppm. None of the median or geometric mean arsenic concentrations at any distance from the boardwalk was elevated in this lower assay zone.

Table I-12—CCA-C: Arsenic concentrations in sediment samples^a

Time of sampling	Distance from boardwalk ^b (cm (in.))	Sample size	Range (ppm)	Median (ppm)	Mean (ppm)	Geometric mean (ppm)	
Upper 2.5 cm (1 in.) of sediment							
Preconstruction	Intended path	9	2-4	2	2	2	
0.5 months	Under	6	6-16	<u>10</u>	11	<u>10</u>	
	0 (0)	6	4-32	9	15	<u>11</u>	
	30 (12)	6	2-18	5	8	6	
	60 (24)	6	4-24	<u>11</u>	12	<u>10</u>	
	150 (59)	6	2-10	7	6	5	
	300 (118)	2	11-12	12	12	<u>12</u>	
2 months	Controls	4	2-4	3	3	3	
	Under	6	22-130	<u>34</u>	51	<u>41</u>	
	0 (0)	6	11-34	<u>17</u>	20	<u>19</u>	
	30 (12)	6	3-28	<u>17</u>	17	<u>14</u>	
	60 (24)	6	5-24	8	12	<u>10</u>	
	150 (59)	6	3-13	8	8	<u>7</u>	
5.5 months	300 (118)	2	12-22	17	18	<u>16</u>	
	Controls	6	3-6	4	4	4	
	Under	6	12-82	<u>49</u>	47	<u>39</u>	
	0 (0)	6	3-88	<u>24</u>	32	<u>17</u>	
	30 (12)	5	5-35	<u>12</u>	15	<u>12</u>	
	60 (24)	6	2-39	8	12	8	
11 months	150 (59)	6	4-9	5	5	5	
	300 (118)	2	4-15	9	9	8	
	Controls	3	1-3	3	2	2	
	Under	6	20-65	<u>41</u>	42	<u>38</u>	
	0 (0)	6	14-58	<u>30</u>	33	<u>33</u>	
	30 (12)	6	10-78	<u>33</u>	36	<u>36</u>	
5.5 months	60 (24)	6	9-42	<u>22</u>	25	<u>25</u>	
	150 (59)	6	2-24	<u>14</u>	14	<u>14</u>	
	300 (118)	6	8-18	<u>13</u>	13	<u>13</u>	
	Controls	10	1-10	6	6	6	
	Lower 2.5-10 cm (1-4 in.) of sediment						
	Preconstruction	Intended path	9	1-3	2	2	2
0.5 months	Under	6	1-13	3	5	3	
	0 (0)	6	1-43	3	10	4	
	30 (12)	6	2-10	3	4	3	
	60 (24)	6	1-8	3	3	3	
	150 (59)	6	1-3	2	2	2	
	300 (118)	2	2-3	3	3	2	
2 months	Control	4	1-2	1	1	1	
	Under	5	3-53	<u>46</u>	36	<u>25</u>	
	0 (0)	6	1-39	<u>12</u>	15	<u>10</u>	
	30 (12)	6	2-20	6	8	5	
	60 (24)	6	2-7	3	4	3	
	150 (59)	6	1-6	2	3	2	
5.5 months	300 (118)	2	5-5	5	5	<u>5</u>	
	Control	4	1-2	2	1	1	
	Under	6	2-10	4	5	4	
	0 (0)	6	1-7	2	3	3	
	30 (12)	5	1-10	3	4	3	
	60 (24)	6	1-5	1	2	2	
11 months	150 (59)	6	1-4	2	2	2	
	300 (118)	2	1-8	5	5	3	
	Control	3	1-1	1	1	1	
	Under	6	2-11	5	6	<u>5</u>	
	0 (0)	6	2-13	6	6	<u>6</u>	
	30 (12)	6	2-19	7	8	6	
5.5 months	60 (24)	6	2-10	3	5	3	
	150 (59)	6	1-3	2	1	1	
	300 (118)	6	1-6	3	4	3	
	Control	10	1-2	2	2	5	

^aUnderlined median and geometric mean values are elevated above background and control levels based on 95% tolerance interval.

^b0 = edge.

At the 11-month inspection, maximum and median concentrations in the top 2.5 cm (1 in.) of sediment under the boardwalk and at zero distance downstream appeared to have leveled off or decreased slightly, while concentrations at greater distances from the boardwalk had continued to increase. Maximum and median concentrations 30 cm (1 ft) downstream were increased to 78 and 33 ppm, respectively; at 1.5 m (5 ft) downstream, median concentration was increased to 14 ppm. The trend for arsenic was similar to that for copper and chromium. After 11 months, arsenic levels directly under and immediately adjacent to the boardwalk appeared to have peaked, while levels downstream had continued to increase as the sediments shifted downstream. Arsenic concentrations in the lower assay zone were slightly higher than those detected at the 5.5-month inspection, but nevertheless much lower than those detected in the upper assay zone.

During the course of the study, elevated arsenic levels were consistently detected 3 m (10 ft) downstream from the boardwalk. However, the consistency of the levels detected at this distance relative to other locations suggests that this area had been contaminated during construction activities. Nevertheless, arsenic apparently moved downstream at least 1.5 m (5 ft) below the boardwalk, and it may have traveled 3 m (10 ft) below the boardwalk by the 11-month inspection. Arsenic is generally thought to have greater environmental mobility than does copper or chromium because it is more water-soluble and less likely to be adsorbed (Lebow 1996). Moreover, like copper and chromium, arsenic can be dispersed through the movement of sediment particles during periods of high water flow.

Comparison of Soil and Sediment CCA Levels

Levels of CCA-C components detected in soil adjacent to the boardwalk were generally not elevated or only slightly elevated. Soil accumulations were much lower than those noted by Stilwell and Gorny (1997) in their report on samples removed from beneath residential decks.

Chromium, copper, and arsenic concentrations in the sediments were generally much higher than those detected in soil. This is somewhat surprising, as one might expect that CCA-C components released into water would be more rapidly dispersed to lower levels than components that drip directly into a localized area of soil. One possible explanation is that a larger volume of wood was used in construction of the boardwalk over the sediments. The vertical columns are much taller in this portion of the boardwalk, and extensive cross-bracing was employed because of the height of the boardwalk.

It is also probable that the portions of the columns exposed to standing water released CCA-C components at a faster rate than did their counterparts above the soil, which were exposed to leaching only during rainfall. This second argument is somewhat flawed, however, because the volume of treated wood exposed in standing water is very small compared to that exposed in the aboveground portions. The vast majority of surface area in each section is exposed to leaching from rainwater only.

A third possibility is that abrasion from foot traffic increased the release of treated particles into the sediment area. The soil samples were removed from the edge of a viewing platform, where foot traffic was probably light compared to that at the center of the boardwalk. In contrast, the sediment samples were removed under the boardwalk and downstream from an elevated portion of the boardwalk, where foot traffic was probably heavier. One way to investigate this last possibility is to compare the ratio of CCA-C components in the sediments to those in the wood. Because CCA-C-treated wood has more chromium than copper and because copper is more leachable than chromium, it would seem reasonable that sediments containing particles of CCA-C-treated wood should contain more chromium than copper (once background levels are subtracted). Accordingly, the ratio of elevated CCA-C components (oxide basis) was computed for those sediment samples that contained elevated levels of chromium after subtracting the appropriate average background levels. As Figure I-5 shows, the ratio of copper to chromium was higher in the contaminated sediments than in the treated wood, especially in sediments directly under the boardwalk. At further distances from the boardwalk, the ratio of copper to chromium decreased, but remained higher than that found in treated wood. Thus, although a portion of the CCA-C components detected in the sediment samples was possibly derived from abraded wood particles, the wood particles were apparently not the primary source of copper elevation in these samples.

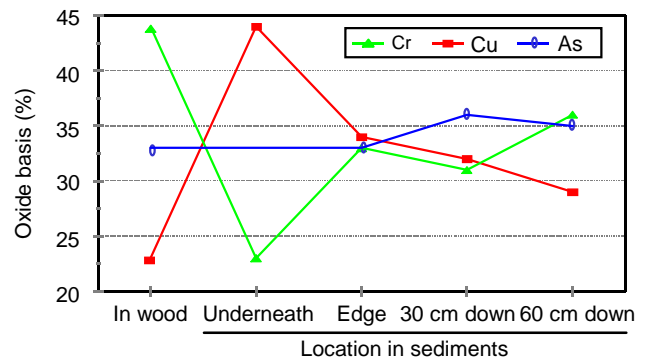

Figure I-5—CCA-C test section: comparison of CCA-C component ratios in wood and sediments. Comparison includes only sediment samples with elevated chromium levels.

Table I-13—Average total amounts of CCA components released from unstained and pre-stained specimens during 17 weeks of leaching in artificial rainfall

Specimen	Copper (mg)	Chromium (mg)	Arsenic (mg)
Unstained	9.15	2.15	5.70 ^a
Pre-stained	8.48	1.67	4.12 ^a

^aMeans found to be significantly different at $p = 0.05$.

Effect of Pre-Stain on CCA Release

Concerns have been raised about the effect of pre-stain on the leaching characteristics of the wood used in this study. To address these concerns, we conducted a side-by-side laboratory comparison of leaching from pre-stained and unstained decking (Lebow and Evans 1999). We found that the use of pre-stain did significantly lower the initial rate of arsenic release, by about 25% to 30%. In addition, the rate of copper and chromium release was apparently lower for pre-stained specimens, but these differences were not statistically significant (Table I-13). Thus, the release of arsenic from the boardwalk may have been somewhat greater if the wood had not been pre-stained. However, the high rainfall and large volume of treated wood used in construction of the test section still represent a very severe leaching hazard.

Conclusions From CCA Studies

Elevated concentrations of copper, chromium and arsenic were detected in some samples removed from rainwater, soil, and sediment adjacent to the CCA-C treated wood. Analysis of rainfall collected from the treated wood revealed that total copper release was greatest between 2 and 5.5 months, while the total release of chromium and arsenic was greatest between 5.5 and 11 months. If viewed as a function of rainfall, however, the rate of release of CCA-C components was highest during the first 2 months and then declined at each subsequent inspection. Very little accumulation of CCA-C components was detected in soil surrounding the CCA-C treated viewing platform. Arsenic was the most elevated, including one sample that was elevated by approximately 30 ppm. Higher levels of CCA-C components were detected in sediments adjacent to the CCA-C-treated elevated walkway. The geometric mean of copper levels in samples removed from directly underneath the boardwalk reached a maximum of 98 ppm, an elevation of approximately 76 ppm above the background level. Chromium and arsenic geometric mean concentrations were elevated by a maximum of approximately 21 and 35 ppm, respectively, in samples removed from under the boardwalk. Levels of CCA-C components in the sediments appeared to peak by 5.5 months after construction, although the levels detected further from the boardwalk increased slightly at the 11-month sampling.

Elevated concentrations of copper and chromium in sediments were primarily confined to within 60 cm (24 in.) of the boardwalk, while geometric mean arsenic levels were elevated as much as 3 m (10 ft) away from the treated wood.

The results show that elevated levels of CCA-C components can be detected in the soil and sediment adjacent to CCA-C-treated wood. Despite the large volume of treated wood used in construction and the high rainfall at the site, generally low levels of CCA-C components were detected, especially in the soil. As discussed in Part II of this paper, the levels of CCA-C components released into the wetland did not have a measurable effect on the diversity or quantity of insect populations at the site.

ACZA Studies

Background ACZA Levels

Background concentrations of copper at the ACZA test site ranged from 23 to 36 ppm in soil and 18 to 24 ppm in the sediment, and they were less than 2 ppb in the wetland water. Background concentrations of zinc were 48 to 70 ppm in the soil, from 42 to 50 ppm in the sediment, and up to 4 ppb in the wetland water. Background concentrations of arsenic ranged from 1 to 4 ppm in the soil and 1 to 3 ppm in the sediment, and they were below 1 ppm in the wetland water.

Rate of ACZA Release in Rainfall

Collection and analysis of rainfall from specimens of the ACZA-treated decking revealed that the greatest total release of copper, zinc, and arsenic occurred between the 6- and 11.5-month inspections (Fig. I-6a). If viewed as a function of rainfall, however, the rate of leaching was highest during the initial exposure period for copper and zinc, and then declined during the next two exposure periods (Fig. I-6b). The release of arsenic was more delayed, peaking during the second exposure period (on a rainfall basis). The amounts of copper and arsenic released became similar during the last two exposure periods, while release of zinc remained substantially lower.

The pre-exposure retention of ACZA components in the outer 15 mm (0.6 in.) of the upper, wide face of the decking was determined by assaying end-matched samples cut from adjacent to the exposure specimens. The average retention was 5.34 kg/m³ (0.33 lb/ft³) for copper oxide, 2.24 kg/m³ (0.14 lb/ft³) for zinc oxide, and 1.60 kg/m³ (0.10 lb/ft³) for arsenic pentoxide, yielding a total ACZA retention of 9.19 kg/m³ (0.57 lb/ft³). This retention is slightly above the target retention of 6.4 kg/m³ (0.4 lb/ft³) specified for the lumber for the boardwalk.

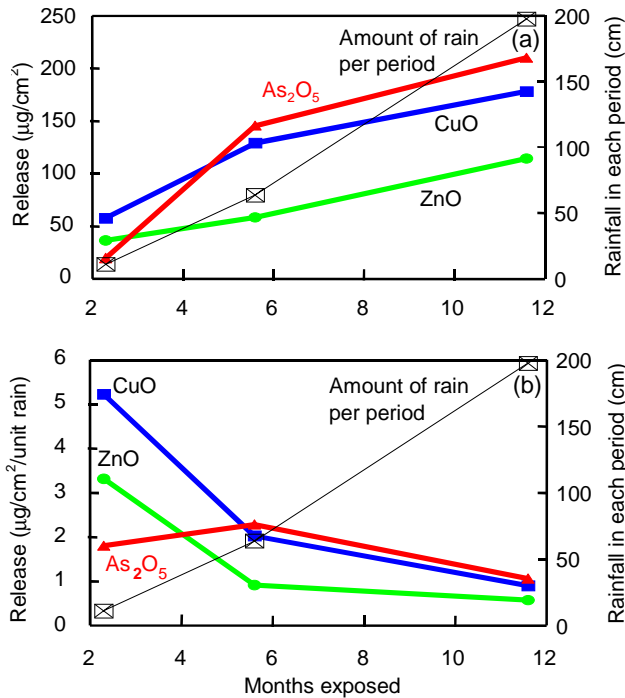

Figure I-6—Release of copper, zinc, and arsenic into rainwater collected from ACZA-treated decking. Rate of release expressed as (a) µg/cm² and (b) µg/cm²/unit rain. 1 unit = 2.54 cm (1 in.).

Accumulation and Mobility of ACZA in Soil

Assay zones used for soil samples were 0 to 15 cm (0 to 6 in.) (upper zone) and 15 to 30 cm (6 to 12 in.) (lower zone). Concentrations of ACZA components in individual samples are shown in Appendix IC.

Copper

Copper concentrations in the soil adjacent to the ACZA-treated boardwalk were elevated in the upper assay zone of some samples removed 10 days after construction (Table I-14, App. IC). Although the maximum copper level detected (111 ppm) was under the edge of the boardwalk, as much as 53 ppm copper was detected in one sample located 60 cm (24 in.) from the boardwalk. The median and geometric mean copper concentrations were slightly elevated in samples removed from under the edge of and 15 cm (6 in.) from the boardwalk, but not at other sampling distances (Table I-14). In the lower assay zone, the only sample with elevated copper was located 60 cm (24 in.) from the boardwalk (Table I-14, App. IC). It is unclear why this particular sample had elevated levels of copper in both the upper and lower assay zones when samples closer to the boardwalk did not, but these results do suggest that the sample was contaminated by a mechanism other than leaching. As noted in the following text, copper concentrations of samples

removed from the upper assay zone of this area were consistently elevated at each inspection.

At the 2.5-month sampling, elevated copper levels were found in samples removed from under the edge of the boardwalk and at 15, 30, and 60 cm (6, 12, and 24 in.) away from the treated wood, although the maximum level detected (82 ppm) was lower than that of the previous sampling. The geometric mean copper concentration was elevated under the edge of the boardwalk and at 15 and 30 cm (6 and 12 in.) from the boardwalk, while the median was elevated at 0 and 30 cm (0 and 12 in.) from the boardwalk. Elevated copper levels were also detected in the lower assay zone of two samples. One sample removed from under the boardwalk had slightly elevated (39 ppm) copper levels, and a second sample removed 30 cm (12 in.) from the boardwalk had substantially elevated (120 ppm) copper levels. Again, it is unclear why copper levels in the lower portion of this sample were so highly elevated in comparison to levels in the upper 15 cm (6 in.) of the same sample. Zinc and arsenic levels were also elevated in the lower portion of this sample, indicating that ACZA is the source of contamination. It is doubtful, however, that leachate could elevate levels in this sample without further increasing levels in samples closer to the boardwalk. Because levels in this area were not elevated at prior or subsequent inspections, it appears that this sample may have been contaminated during collection or subsequent processing at the laboratory.

At the 6-month inspection, maximum and geometric mean levels of copper detected in the upper 15 cm (6 in.) of soil increased for samples removed from directly under the edge of the boardwalk. Copper levels in samples removed 15 and 30 cm (6 and 12 in.) from the boardwalk apparently had decreased since the previous inspection, but increased copper concentrations were again detected at 60 cm (24 in.) from the boardwalk in the same area that had contained elevated copper concentrations at the previous two inspections. No elevation of copper was detected in the lower assay zone of the soil samples at any location.

Substantial increases in copper levels under the edge of the boardwalk and at 15 cm (6 in.) from the boardwalk were noted at the 11.5-month inspection. A maximum of 459 ppm copper was detected in the upper 15 cm (6 in.) of a sample removed from directly under the boardwalk, and the median copper level in samples in this area had increased to 126 ppm. Slightly elevated levels were again detected in the upper 15 cm (6 in.) of samples removed at 30 and 60 cm from the boardwalk, but increases at these distances were small compared to those in samples closer to the boardwalk. In the lower assay zone, copper levels were elevated in one sample removed from directly under the boardwalk and in two samples removed 15 cm (6 in.) from the boardwalk. In one of these samples, copper was substantially elevated to 204 ppm. The increase in copper levels immediately adjacent

Table I-14—ACZA: Copper concentrations in soil samples^a

Time of sampling	Distance from boardwalk ^b (cm (in.))	Sample size	Range (ppm)	Median (ppm)	Mean (ppm)	Geometric mean (ppm)
Upper 15 cm (6 in.) of soil						
Preconstruction	Intended path	20	24–36	29	29	28
0.3 months	0 (0)	7	35–111	<u>43</u>	51	<u>46</u>
	15 (6)	7	29–37	<u>34</u>	33	<u>33</u>
	30 (12)	7	28–35	32	32	<u>32</u>
	60 (24)	7	28–53	31	35	<u>35</u>
2.5 months	Control	4	26–27	27	27	27
	0 (0)	7	34–82	<u>50</u>	51	<u>49</u>
	15 (6)	7	30–56	33	39	<u>37</u>
	30 (12)	7	31–50	<u>34</u>	37	<u>36</u>
6 months	60 (24)	7	28–48	31	33	33
	Control	4	23–28	26	25	25
	0 (0)	7	34–150	<u>51</u>	76	<u>65</u>
	15 (6)	7	28–46	31	34	33
11.5 months	30 (12)	7	28–40	33	34	34
	60 (24)	7	31–64	<u>35</u>	38	<u>37</u>
	Control	4	26–29	27	27	27
	0 (0)	7	37–459	<u>126</u>	197	<u>140</u>
	15 (6)	7	31–122	<u>40</u>	57	<u>49</u>
	30 (12)	7	29–59	32	37	<u>36</u>
	60 (24)	7	27–41	28	30	30
	Control	4	25–32	26	27	27
Lower 15–30 cm (6–12 in.) of soil						
Preconstruction	Intended path	19	23–33	29	28	28
0.3 months	0 (0)	7	22–30	28	27	27
	15 (6)	7	23–31	27	28	28
	30 (12)	7	24–29	27	27	27
	60 (24)	7	22–44	24	27	26
2.5 months	Control	4	25–30	27	27	27
	0 (0)	6	26–39	30	31	30
	15 (6)	6	27–29	28	28	28
	30 (12)	6	26–120	28	43	<u>35</u>
6 months	60 (24)	7	25–31	29	28	28
	Control	4	27–29	29	29	29
	0 (0)	6	28–35	29	30	30
	15 (6)	7	22–30	26	26	26
11.5 months	30 (12)	6	26–34	28	29	29
	60 (24)	5	23–31	28	28	28
	Control	4	26–32	29	29	29
	0 (0)	7	28–79	32	38	<u>35</u>
	15 (6)	6	28–204	33	67	<u>49</u>
	30 (12)	5	26–33	31	30	30
	60 (24)	7	26–33	28	29	28
	Control	4	27–35	30	30	30

^aUnderlined median and geometric mean values are elevated above background and control levels based on 95% tolerance interval.

^b0 = dripline.

to the boardwalk at the 11.5-month inspection appears somewhat out of proportion to the slight increase in release noted from the decking specimens during the 6- to 11.5-month exposure period (Fig. I-6a). The larger size and vertical orientation of some members used in construction of the boardwalk may have delayed release somewhat in comparison to that in the horizontally placed decking specimens.

Zinc

Zinc levels in the soil were generally not as elevated as copper levels. Rainfall collection from the ACZA-treated decking indicated that the amount of zinc released at each interval was only 45% to 65% of the amount of copper released (Fig. I-6). This difference is not surprising, as it reflects the proportions of these components in the treated wood. At the 10-day inspection, only one sample, which was removed from the upper 15 cm (6 in.) of soil from directly under the edge of the boardwalk, contained a slightly elevated level of zinc (Table I-15, App. IC). No samples contained elevated zinc levels in the lower assay zone.

At the 2.5-month inspection, no elevated zinc levels were detected in the upper 15 cm (6 in.) of the soil samples. One sample removed 30 cm (12 in.) from the boardwalk did contain elevated zinc levels in the lower assay zone. This is the same sample that contained elevated levels of copper and arsenic. As discussed previously, it is unlikely that this sample was contaminated by leachate from the boardwalk.

At the 6-month inspection, elevated zinc levels were detected in several samples removed from the top 15 cm (6 in.) of soil directly under the edge of the boardwalk. Three samples contained more than 100 ppm zinc, increasing the median and geometric mean levels in that area to 70 and 82 ppm, respectively (Table I-15). The upper assay zone of one sample removed at 15 cm (6 in.) from the boardwalk, two samples removed at 30 cm (12 in.), and four samples removed at 60 cm (24 in.) also appeared to have very slightly elevated zinc concentrations. However, no elevated levels of zinc were found in the lower assay zone of the samples.

In a trend similar to that of copper, zinc concentrations showed a substantial increase in the top 15 cm (6 in.) of soil removed from directly under the boardwalk at the 11.5-month inspection. All but one sample removed from under the edge of the boardwalk had elevated zinc, and the zinc in one sample was as high as 275 ppm, bringing the median and geometric mean zinc levels up to 98 and 114 ppm, respectively. However, the increased zinc levels were very localized; only one elevated concentration was detected at 15 cm (6 in.) and at 30 cm (24 in.) from the boardwalk. In the lower assay zone, elevated zinc concentrations were detected in only three samples: two samples removed 15 cm (6 in.) from the boardwalk and one removed 60 cm (24 in.) from the boardwalk. The geometric mean zinc

concentration was slightly elevated in samples removed 30 cm (6 in.) from the boardwalk (Table I-15).

Arsenic

Significant elevation of arsenic in the soil samples was not detected until 6 months after construction (Table I-16, App. IC). As indicated in Figure I-6, the quantity of arsenic released from the decking specimens was initially lower than that of copper and zinc, but then surpassed these metals at the 6- and 11.5-month inspections. Elevated levels of arsenic were found in the lower assay zone of one sample removed at the 10-day inspection and of two samples removed at the 2.5-month inspection. As discussed for copper and zinc, as a result of leaching elevation of ACZA components at the 30- and 60-cm (12- and 24-in.) distances for the D3 transect is puzzling because little elevation was detected at the 0- and 30-cm (0- and 12-in.) distances.

At the 6-month inspection, elevated arsenic levels were detected in the upper 15 cm (6 in.) of at least one sample removed at all distances (except controls) from the treated wood. Median and geometric mean arsenic levels were elevated under the boardwalk and 15 and 30 cm (6 and 12 in.) from the boardwalk. Arsenic accumulation was primarily confined to the upper 15 cm (6 in.) of soil; only one sample, which was removed from under the edge of the boardwalk, contained elevated arsenic levels in the lower assay zone.

Arsenic concentrations under the edge and 15 cm (6 in.) from the boardwalk increased sharply at the 11.5-month inspection. In the upper assay zone, the highest concentrations were found directly under the edge of the boardwalk, where the maximum concentration detected was increased to 159 ppm and the median concentration to 51 ppm. Further away from the boardwalk, little increase in median or geometric mean arsenic concentrations was detected, although there was an increase (96 ppm) in the maximum concentration of arsenic detected 15 cm (6 in.) from the boardwalk. Although the lower assay zone revealed a substantial increase in maximum arsenic levels detected directly under and 15 cm (6 in.) from the boardwalk, most samples did not have elevated arsenic levels.

Limits on Mobility of ACZA Components in Soil

Elevated levels of arsenic and zinc were detected as much as 60 cm (24 in.) away from the boardwalk, although the samples with elevated levels were generally found within 15 cm (6 in.) of the boardwalk. One sample area situated 60 cm (24 in.) from the boardwalk also contained elevated copper concentrations. However, as previously discussed, the circumstances indicate that this sample was not contaminated by leachate. Arsenic appeared to be slightly more mobile horizontally; elevated levels were found in the lower assay zone of one sample at 60 cm (24 in.) from the boardwalk. The downward movement of copper, zinc, and arsenic was

Table I-15—ACZA: Zinc concentrations in soil samples^a

Time of sampling	Distance from boardwalk ^b (cm (in.))	Sample size	Range (ppm)	Median (ppm)	Mean (ppm)	Geometric mean (ppm)
Upper 15 cm (6 in.) of soil						
Preconstruction	Intended path	20	50–70	59	58	58
0.3 months	0 (0)	7	48–87	67	66	65
	15 (6)	7	60–66	63	63	63
	30 (12)	7	61–71	<u>66</u>	66	<u>66</u>
	60 (24)	7	58–69	60	62	61
2.5 months	Control	4	52–59	57	56	56
	0 (0)	7	53–64	62	60	60
	15 (6)	7	52–62	56	57	57
	30 (12)	7	56–66	58	59	59
6 months	60 (24)	7	56–68	59	61	61
	Control	4	50–55	53	53	53
	0 (0)	7	64–112	<u>70</u>	84	<u>82</u>
	15 (6)	7	53–75	68	65	65
11.5 months	30 (12)	7	63–80	<u>68</u>	70	<u>70</u>
	60 (24)	7	68–91	<u>75</u>	77	<u>77</u>
	Control	4	64–67	67	66	66
	0 (0)	7	62–275	<u>98</u>	129	<u>114</u>
	15 (6)	7	60–88	64	67	66
	30 (12)	7	55–77	61	63	63
	60 (24)	7	39–75	59	56	55
	Control	4	50–55	52	52	52
Lower 15–30 cm (6–12 in.) of soil						
Preconstruction	Intended path	19	48–63	57	55	55
0.3 months	0 (0)	7	46–57	50	51	51
	15 (6)	7	45–56	55	51	51
	30 (12)	7	49–58	52	53	52
	60 (24)	7	44–60	49	50	50
2.5 months	Control	4	51–57	54	54	54
	0 (0)	6	51–65	55	56	56
	15 (6)	6	57–63	62	61	61
	30 (12)	6	47–88	55	59	58
6 months	60 (24)	7	48–55	52	51	51
	Control	4	52–61	55	55	55
	0 (0)	6	45–52	50	49	49
	15 (6)	7	42–51	48	47	47
11.5 months	30 (12)	6	30–48	44	42	42
	60 (24)	5	26–48	30	36	35
	Control	4	42–54	47	47	47
	0 (0)	7	50–70	56	58	57
	15 (6)	6	52–141	61	80	<u>74</u>
	30 (12)	5	50–58	56	55	55
	60 (24)	7	48–57	55	54	54
	Control	4	49–61	59	57	57

^aUnderlined median and geometric mean values are elevated above background and control levels based on 95% tolerance interval.

^b0 = dripline.

Table I-16—ACZA: Arsenic concentrations in soil samples^a

Time of sampling	Distance from boardwalk ^b (cm (in.))	Sample size	Range (ppm)	Median (ppm)	Mean (ppm)	Geometric mean (ppm)
Upper 15 cm (6 in.) of soil						
Preconstruction	Intended path	20	1–4	2	2	2
0.3 months	0 (0)	7	3–7	4	4	4
	15 (6)	7	2–4	3	3	3
	30 (12)	7	1–3	2	2	2
	60 (24)	7	3–6	<u>4</u>	4	<u>4</u>
2.5 months	Control	4	2–3	3	2	2
	0 (0)	7	1–1	1	1	1
	15 (6)	7	1–1	1	1	1
	30 (12)	6	1–1	1	1	1
	60 (24)	7	1–2	1	2	2
6 months	Control	4	1–2	1	1	1
	0 (0)	7	1–51	13	17	<u>9</u>
	15 (6)	7	6–23	<u>9</u>	10	<u>9</u>
	30 (12)	7	2–21	<u>6</u>	8	<u>6</u>
	60 (24)	7	1–13	6	7	<u>5</u>
11.5 months	Control	4	1–5	1	2	2
	0 (0)	7	9–159	<u>51</u>	75	<u>53</u>
	15 (6)	7	1–96	7	24	<u>10</u>
	30 (12)	7	5–17	<u>7</u>	9	<u>8</u>
	60 (24)	7	4–14	<u>4</u>	6	<u>5</u>
	Control	4	3–5	3	4	4
Lower 15–30 cm (6–12 in.) of soil						
Preconstruction	Intended path	19	1–3	2	2	2
0.3 months	0 (0)	7	3–4	3	4	4
	15 (6)	7	3–4	4	4	4
	30 (12)	7	3–4	4	4	4
	60 (24)	7	3–10	4	5	4
	Control	4	3–5	3	4	3
2.5 months	0 (0)	6	3–9	3	4	4
	15 (6)	6	4–5	4	4	4
	30 (12)	6	2–15	3	5	4
	60 (24)	7	2–3	3	2	2
	Control	4	2–3	3	3	3
6 months	0 (0)	6	4–9	5	5	5
	15 (6)	7	2–5	4	3	3
	30 (12)	6	3–5	4	4	4
	60 (24)	5	3–4	4	4	4
	Control	4	3–4	4	4	4
11.5 months	0 (0)	7	5–23	<u>8</u>	10	<u>9</u>
	15 (6)	6	4–143	5	45	<u>14</u>
	30 (12)	5	4–7	5	5	5
	60 (24)	7	3–9	4	5	4
	Control	4	3–5	4	4	4

^aUnderlined median and geometric mean values are elevated above background and control levels based on 95% tolerance interval.

^b0 = dripline.

limited, although individual samples did contain elevated concentrations of each component in the lower assay zone 11.5 months after construction.

The upper 15 cm (6 in.) of soil at this site is classified as sandy loam, with approximately 60% sand, 38% silt, and 7% clay, while the lower assay zone (15 to 30 cm (6 to 12 in.)) is classified as a gravelly sandy loam, with similar percentages of sand, silt, and clay, but a higher proportion of gravel. The sandy nature of the soil at this site might have been expected to allow leached ACZA components to be relatively mobile, especially downward. The porosity of the soil may have helped to limit horizontal movement of leached components, since relatively little puddling or flow along occurred along the soil surface at the site. The limited mobility observed is also evidence of the reactivity of ACZA components with soil constituents, even under conditions that may promote their movement.

Accumulation and Mobility of ACZA in Sediment

Assay zones for sediment samples were 0 to 2.5 cm (0 to 1 in.) (upper zone) and 2.5 to 10 cm (1 to 4 in.) (lower zone). Concentrations of ACZA components in individual sediment samples are shown in Appendix IC.

Copper

Ten days after construction, elevated levels of copper were detected in the top 2.5 cm (1 in.) of individual samples removed 0, 30, and 60 cm (0, 12 and 24 in.) from the viewing platform (App. IC). Median and geometric mean copper concentrations showed little increase at any distance, although the geometric mean was slightly elevated at 0 and 60 cm (0 and 2 ft) from the boardwalk (Table I-17). Little, if any copper elevation was noted in the lower assay zone of any samples (Table I-17, App. IC).

An increase in maximum copper concentrations was detected in sediment samples removed 2.5 months after construction. Maximum quantities detected in the top 2.5 cm (1 in.) of sediment ranged from 569 ppm directly under the platform to 85 ppm at 60 cm (24 in.) from the platform. Median levels, however, were not as drastically elevated, revealing that copper accumulations were very localized. Low, stagnant water levels at this August sampling apparently allowed released copper to accumulate in the sediments near the viewing platform. As shown in Appendix IC, the highest accumulations were detected in transects 1 and 7, which were nearest the shoreline and had the lowest water levels. Transect 7, for example, was actually above the waterline during the 2.5-month sampling. This apparently allowed released copper to accumulate to higher levels immediately under the edge of the boardwalk. An increase in maximum levels was also detected in the lower assay zone; one sample contained 146 ppm copper (Table I-17, App. IC). However, areas of

accumulation were again very localized—median levels were not elevated at any distance from the boardwalk.

At the 6-month inspection, maximum levels of copper detected in the upper 2.5 cm (1 in.) of sediment were decreased, although at least one sample with elevated copper was detected at each distance from the platform. Median and geometric mean concentrations had also declined slightly, and they were only statistically elevated at 0 or 30 cm (0 or 12 in.) from the platform. The decrease in copper concentrations was even more notable in the lower (2.5- to 10-cm (1- to 4-in.)) assay zone; none of these samples contained elevated copper concentrations. The increased rainfall and high water levels that occurred between the 2.5- and 6-month inspections apparently flushed and dispersed copper that had previously accumulated in the sediments.

At the 11.5-month inspection, maximum copper concentrations detected in the upper 2.5 cm (1 in.) of sediment remained about the same as that observed at the 6-month inspection, but geometric mean and median concentrations were increased under the edge of the boardwalk. Areas of copper accumulation appeared to have become slightly more widespread, probably as a result of both additional leaching during the last exposure period and continued dispersion of previous copper accumulations. Nevertheless, only two samples had very slightly elevated copper concentrations at 1.5 m (5 ft) from the platform and none had elevated concentrations at 3 m (10 ft) from the platform. Increased maximum and median copper concentrations were also noted for the lower assay zone of samples removed from under the edge and 30 cm (12 in.) away from the platform. As expected, concentrations in the lower assay zone were not as elevated as those in the upper assay zone.

During the course of this study, elevated levels of copper in individual samples were found as far as 1.5 m (5 ft) from the platform, although median and geometric mean concentrations were typically elevated only within 60 cm (24 in.) of the platform. The quantity of fine sediments at the site, as well as the localized pattern of copper distribution, suggests that the majority of copper released from the wood rapidly becomes associated with sedimentary material. Further mobility is likely to occur primarily when the sediments themselves are dislodged by high water or other types of disturbances.

Zinc

Ten days after construction, elevated levels of zinc were detected in the upper 2.5 cm (1 in.) of at least one sample removed at all distances (except controls) from the platform (App. IC). Geometric mean zinc concentrations were elevated 0, 30 and 60 cm (0, 12 and 24 in.) from the boardwalk, and median concentrations were elevated at 0 and 30 cm (0 and 12 in.) from the treated wood (Table I-18).

Table I-17—ACZA: Copper concentrations in sediment samples^a

Time of sampling	Distance from boardwalk ^b (cm (in.))	Sample size	Range (ppm)	Median (ppm)	Mean (ppm)	Geometric mean (ppm)
Upper 2.5 cm (1 in.) of sediment						
Preconstruction	Intended path	10	18–21	19	19	19
0.3 months	0 (0)	7	23–104	28	47	<u>39</u>
	30 (12)	7	19–64	28	35	32
	60 (24)	7	20–112	24	47	<u>38</u>
	150 (59)	7	18–30	20	22	21
	300 (118)	—	—	—	—	—
2.5 months	Control	3	19–22	19	20	20
	0 (0)	7	29–569	<u>47</u>	173	<u>81</u>
	30 (12)	7	27–122	31	50	<u>43</u>
	60 (24)	7	24–85	30	40	<u>36</u>
	150 (59)	7	19–226	<u>35</u>	64	<u>44</u>
6 months	300 (118)	—	—	—	—	—
	Control	4	16–22	18	19	18
	0 (0)	7	18–208	31	63	<u>43</u>
	30 (12)	7	20–64	<u>39</u>	39	<u>37</u>
	60 (24)	7	20–47	23	27	26
11.5 months	150 (59)	7	11–34	22	23	21
	300 (118)	—	—	—	—	—
	Control	4	18–23	19	20	20
	0 (0)	7	28–290	<u>88</u>	102	<u>75</u>
	30 (12)	7	20–130	<u>39</u>	57	<u>48</u>
6 months	60 (24)	7	20–40	29	29	28
	150 (59)	7	23–35	25	28	28
	300 (118)	7	16–25	20	21	20
	Control	6	17–26	21	21	21
	Lower 2.5–10 cm (1–4 in.) of sediment					
Preconstruction	Intended path	11	20–24	21	21	21
0.3 months	0 (0)	6	21–32	23	24	24
	30 (12)	7	21–34	24	25	25
	60 (24)	7	19–32	22	23	22
	150 (59)	7	20–23	22	21	21
	300 (118)	—	—	—	—	—
2.5 months	Control	4	17–24	20	20	20
	0 (0)	7	17–98	25	39	32
	30 (12)	7	17–146	21	39	28
	60 (24)	7	19–114	21	36	28
	150 (59)	7	19–26	20	22	22
6 months	300 (118)	—	—	—	—	—
	Control	4	18–24	21	21	21
	0 (0)	7	20–29	23	25	24
	30 (12)	5	19–31	23	24	24
	60 (24)	5	21–25	23	23	23
11.5 months	150 (59)	5	22–25	23	23	23
	300 (118)	—	—	—	—	—
	Control	4	24–26	26	25	25
	0 (0)	7	24–180	<u>43</u>	59	<u>46</u>
	30 (12)	7	23–64	<u>39</u>	42	<u>39</u>
6 months	60 (24)	7	20–43	25	29	28
	150 (59)	7	19–32	25	24	24
	300 (118)	—	—	—	—	—
	Control	6	21–25	23	23	23

^aUnderlined median and geometric mean values are elevated above background and control levels based on 95% tolerance interval.

^b0 = edge.

Table I-18—ACZA: Zinc concentrations in sediment samples^a

Time of sampling	Distance from boardwalk ^b (cm (in.))	Sample size	Range (ppm)	Median (ppm)	Mean (ppm)	Geometric mean (ppm)
Upper 2.5 cm (1 in.) of sediment						
Preconstruction	Intended path	10	42–50	47	47	47
0.3 months	0 (0)	7	60–136	<u>99</u>	94	<u>89</u>
	30 (12)	7	48–102	<u>72</u>	73	<u>71</u>
	60 (24)	7	54–133	57	78	<u>73</u>
	150 (59)	7	47–109	55	60	58
	300 (118)					
2.5 months	Control	3	53–57	55	55	55
	0 (0)	7	59–1048	<u>114</u>	385	<u>213</u>
	30 (12)	7	66–177	<u>74</u>	98	<u>92</u>
	60 (24)	7	58–110	<u>79</u>	80	<u>78</u>
	150 (59)	7	49–167	63	81	74
6 months	Control	4	45–57	46	49	48
	0 (0)	7	50–170	<u>98</u>	97	<u>91</u>
	30 (12)	7	55–105	<u>86</u>	88	<u>86</u>
	60 (24)	7	53–109	64	71	<u>69</u>
	150 (59)	7	41–87	61	62	61
11.5 months	Control	4	48–58	53	53	53
	0 (0)	7	74–354	<u>106</u>	158	<u>136</u>
	30 (12)	7	57–198	<u>159</u>	135	<u>123</u>
	60 (24)	7	50–118	<u>73</u>	80	<u>77</u>
	150 (59)	7	59–126	65	77	<u>75</u>
300 (118)	7	46–74	65	61	60	
Control	6	44–68	56	56	55	
Lower 2. 5–10 cm (1–4 in.) of sediment						
Preconstruction	Intended path	11	42–48	45	45	45
0.3 months	0 (0)	6	50–78	62	63	<u>62</u>
	30 (12)	7	47–71	63	60	60
	60 (24)	7	38–69	56	55	54
	150 (59)	7	44–60	52	52	52
	300 (118)					
2.5 months	Control	4	45–61	48	50	50
	0 (0)	7	41–131	78	78	<u>72</u>
	30 (12)	7	40–187	52	75	65
	60 (24)	7	44–119	52	61	57
	150 (59)	7	42–62	50	51	50
6 months	Control	4	42–61	47	49	49
	0 (0)	7	47–317	53	90	68
	30 (12)	5	49–60	54	54	54
	60 (24)	5	51–65	57	57	57
	150 (59)	5	55–64	61	59	59
11.5 months	Control	4	41–55	49	49	48
	0 (0)	7	52–626	<u>86</u>	207	<u>138</u>
	30 (12)	7	55–289	<u>90</u>	122	<u>102</u>
	60 (24)	7	36–127	59	64	59
	150 (59)	7	47–88	53	59	57
300 (118)	7	49–63	53	55	54	
Control	6	53–59	56	56	56	

^aUnderlined median and geometric mean values are elevated above background and control levels based on 95% tolerance interval.

^b0 = edge.

In the lower assay zone, very slightly elevated zinc concentrations were detected in single samples removed from under the edge of the boardwalk and at 30 cm (12 in.) from the boardwalk (Table I-18, App. IC).

As noted with copper, sharp increases in maximum zinc levels were detected in the sediments at the 2.5-month inspection. Maximum concentrations were increased at all distances from the treated wood, and median concentrations were elevated at 0, 30, and 60 cm (0, 12, and 24 in.) from the platform. The highest concentration detected under the edge of the platform was 1,048 ppm, and two other samples in this area contained more than 600 ppm zinc. Zinc concentrations in the lower assay zone were not as elevated, but maximum concentrations detected were increased substantially under the edge of the boardwalk and at 30 and 60 cm (12 and 24 in.) from the treated wood. The median level in the lower assay zone was slightly elevated in samples removed from under the edge of the boardwalk. As noted for copper, the low, stagnant water levels at this August sampling may have allowed released zinc to accumulate in the sediments near the viewing platform.

It is important to note that another source of zinc, the heavy galvanization used on hardware, was present along with the zinc in the ACZA-treated wood. To estimate the amount of zinc released into sediments by the galvanized hardware, zinc concentrations were measured in sediments surrounding the ACQ-B test platform located upstream. ACQ-B-treated wood does not contain zinc, and so we could assume that any elevation in sediment zinc concentrations around the ACQ-B platform were attributable to releases from the galvanized hardware. The galvanized hardware did release appreciable quantities of zinc into the sediments around the ACQ-B platform (Table I-19). At the 2.5-month inspection, nine sediment samples contained elevated zinc concentrations and the concentrations of two of these samples were elevated to more than 100 ppm. By the 11.5-month inspection, many more samples had elevated zinc concentrations; as much as 403 ppm zinc was detected in the upper 2.5 cm (1 in.), and concentrations of as high as 243, 662, and 871 ppm were detected in the lower (2.5- to 10-cm (1- to 4-in.) assay zone. Although the ACQ-B and ACZA sites are not directly comparable in all ways, they do contain roughly equivalent volumes of galvanized hardware. The sediment zinc concentrations noted at the ACQ-B site demonstrate that caution must be used in interpreting the results of zinc concentrations detected at the ACZA site. Particularly doubtful are the extreme levels, such as the 1,048 ppm detected at the 2.5-month inspection. It is likely that these very high levels result from the presence of zinc particles that have been released from the hardware. In addition, even the lower zinc concentrations noted around the ACZA platform are probably caused in part by release from the galvanized hardware.

Concentrations of zinc detected in the upper 2.5 cm (1 in.) of sediments generally were decreased at the 6-month

inspection. As was noted with copper, higher water between the 2.5- and 6-month inspections may have dispersed some sediments that had previously accumulated zinc. This was especially true of maximum zinc values, although at least one sample with elevated zinc concentrations was found at each distance from the platform. Median zinc concentrations remained elevated under the edge of the platform and 30 cm (1 ft) from the platform, while geometric mean concentrations were elevated at 0, 30, and 60 cm (0, 12, and 24 in.) from the platform. In the lower assay zone, one sample removed from under the edge of the platform contained 317 ppm zinc, while no other samples removed at the 6-month inspection had elevated zinc levels in the lower assay zone. Again, this type of highly elevated, very isolated zinc concentration suggests that a particle of galvanization material may have been detected.

Like copper, zinc concentrations in the upper 2.5 cm (1 in.) of sediment were increased at the 11.5-month inspection. Elevated zinc concentrations were again detected at all distances from the platform, including the 3-m (10-ft) distance added at this inspection. Median zinc concentrations were elevated under the edge of the platform and at 30 and 60 cm (12 and 24 in.) from the treated wood. Zinc concentrations were also increased in the lower assay zone. A maximum of 626 ppm zinc was detected in one sample removed from under the edge of the platform, and at least one sample with elevated zinc was noted at each distance up to 1.5 m (5 ft) from the platform. Median zinc concentrations were elevated in the lower assay zone under the edge of the platform and 30 cm (12 in.) away from the platform. Considering the high (626-ppm) zinc concentration detected in one sample, it is worth noting that zinc concentrations of 662 and 871 ppm were found in the lower assay zone of samples adjacent to the platform treated with ACQ-B (which does not contain zinc) at the 11.5-month inspection.

During the course of this study, elevated zinc concentrations in individual samples were detected at 1.5 m (5 ft) from the platform, and in one case, at 3 m (10 ft). Median and geometric mean zinc concentrations were typically not elevated more than 60 cm (24 in.) from the boardwalk.

Arsenic

Maximum arsenic concentrations in sediment samples removed from under the edge of the platform and at 30 and 60 cm (1 and 2 ft) from the boardwalk were elevated within 10 days of construction (Table I-20, App. IC). The highest concentration detected was 24 ppm, noted in the upper 2.5 cm (1 in.) of sediment in samples removed from both under the edge of the boardwalk and 60 cm (24 in.) from the boardwalk. The maximum arsenic concentration detected in the lower assay zone was 7 ppm, a slightly elevated level for this assay zone. Median arsenic concentrations were not elevated at any distance for either the upper or lower assay zone.

Table I-19—Zinc concentrations in sediment samples adjacent to ACQ-B platform^a

Time of sampling	Distance from boardwalk ^b (cm (in.))	Sample size	Range (ppm)	Median (ppm)	Mean (ppm)	Geometric mean (ppm)
Preconstruction (upper zone)	Intended path	10	43–54	50	50	50
0.3 months (upper zone)	0 (0)	7	57–115	<u>69</u>	75	<u>73</u>
	30 (12)	7	51–78	<u>65</u>	63	62
	60 (24)	7	59–101	64	63	<u>71</u>
	150 (59)	7	52–66	61	60	60
	300 (118)	—	—	—	—	—
2.5 months (upper zone)	Control	4	48–53	50	51	51
	0 (0)	7	65–120	<u>103</u>	92	<u>90</u>
	30 (12)	7	49–76	<u>67</u>	65	<u>65</u>
	60 (24)	6	52–73	60	61	61
	150 (59)	7	57–74	60	62	62
11.5 months (upper zone)	300 (118)	—	—	—	—	—
	Control	4	46–53	49	50	50
	0 (0)	9	64–403	<u>106</u>	129	<u>108</u>
	30 (12)	12	65–233	<u>83</u>	107	<u>97</u>
	60 (24)	4	66–87	67	72	<u>71</u>
11.5 months (lower zone)	150 (59)	5	56–68	61	62	61
	300 (118)	4	54–65	60	60	60
	Control	4	43–58	55	52	51
	0 (0)	7	65–871	<u>98</u>	297	<u>171</u>
	30 (12)	6	46–91	64	66	<u>65</u>
11.5 months (lower zone)	60 (24)	7	41–78	68	61	60
	150 (59)	7	45–75	62	61	61
	300 (118)	7	51–69	59	59	59
	Control	10	41–61	50	50	50

^aUnderlined median and geometric mean values are elevated above background and control levels based on 95% tolerance interval.

^b0 = edge.

Increased arsenic concentrations were detected at the 2.5-month inspection. Increased maximum concentrations were detected at all distances from the platform, with an overall maximum of 53 ppm in the upper 2.5 cm (1 in.) of a sample removed from under the edge of the platform. The median arsenic concentration was slightly elevated both under the edge of the platform and 1.5 m (5 ft) from the platform. Arsenic levels were generally less elevated in the lower assay zone (Table I-20, App. IC), although individual samples with elevated arsenic were detected at 0, 30, and 60 cm (0, 12, and 24 in.) from the platform.

At the 6-month inspection, arsenic concentrations in the upper 2.5 cm (1 in.) of sediments dropped slightly but did not decrease as sharply as copper and zinc concentrations. Maximum concentrations detected were lower at 0.3 and 1.5 m (1 and 5 ft) from the platform, but the same or higher under the edge of and 0.6 m (2 ft) away from the platform. Median and geometric mean arsenic concentrations were slightly decreased at each distance from the boardwalk. The decline in arsenic concentrations was slightly more noticeable in the lower assay zone, where elevated samples were detected only under the edge of the platform and 1.5 m (5 ft) away from the platform.

At the 11.5-month inspection, maximum arsenic concentrations in the top 2.5 cm (1 in.) of sediment appeared to decline slightly at some distances from the platform; no elevated samples were detected at 1.5 and 3 m (5 and 10 ft) from the platform. However, median and geometric mean arsenic concentrations were increased under the edge of the platform. In the lower assay zone, arsenic elevation was detected in a few samples (as high as 82 ppm in one sample), but median arsenic concentrations were not elevated at any distance from the platform.

Arsenic accumulations in the wetland sediments were somewhat low in comparison to those of copper and zinc, and in comparison to their relative release rates noted for the decking specimens (Fig. I-6a). It is possible that the higher water solubility of arsenic allowed it to be further dispersed and diffused in the wetland, but this increased mobility was not reflected in samples removed at greater distances from the boardwalk. Generally, more samples taken 1.5 and 3 m (5 and 10 ft) from the boardwalk contained elevated concentrations of zinc as opposed to arsenic. Elevated arsenic concentrations were initially detected at up to 1.5 m (5 ft) from the platform, but at the 6- and 11.5-month inspections, arsenic concentrations were not elevated at distances greater than

Table I-20—ACZA: Arsenic concentrations in sediment samples^a

Time of sampling	Distance from boardwalk ^b (cm (in.))	Sample size	Range (ppm)	Median (ppm)	Mean (ppm)	Geometric mean (ppm)
Upper 2.5 cm (1 in.) of sediment						
Preconstruction 0.3 months	Intended path	10	1–2	2	2	2
	0 (0)	7	3–24	<u>5</u>	10	<u>7</u>
	30 (12)	7	2–14	4	6	5
	60 (24)	7	2–24	4	8	5
	150 (59)	7	2–7	4	4	3
	300 (118)	—	—	—	—	—
2.5 months	Control	3	2–2	2	2	2
	0 (0)	7	5–53	<u>7</u>	15	<u>10</u>
	30 (12)	7	4–27	<u>5</u>	9	<u>7</u>
	60 (24)	7	3–27	4	8	<u>6</u>
	150 (59)	7	2–14	6	7	<u>6</u>
	300 (118)	—	—	—	—	—
6 months	Control	4	2–3	3	3	3
	0 (0)	7	2–56	5	15	<u>7</u>
	30 (12)	7	2–16	5	6	5
	60 (24)	7	1–49	2	9	3
	150 (59)	7	0–6	3	3	3
	300 (118)	—	—	—	—	—
11.5 months	Control	4	2–5	2	3	2
	0 (0)	7	3–46	<u>16</u>	18	<u>13</u>
	30 (12)	7	1–19	6	8	5
	60 (24)	7	3–6	3	4	6
	150 (59)	7	1–5	3	3	2
	300 (118)	7	1–3	2	2	2
	Control	6	1–5	3	3	3
Lower 2. 5–10 cm (1–4 in.) of sediment						
Preconstruction 0.3 months	Intended path	11	2–3	2	2	2
	0 (0)	6	2–3	2	2	2
	30 (12)	7	1–4	3	3	3
	60 (24)	7	1–7	2	3	3
	150 (59)	7	2–2	2	2	2
	300 (118)	—	—	—	—	—
2.5 months	Control	4	1–2	1	1	1
	0 (0)	7	1–14	3	4	3
	30 (12)	7	1–18	1	4	2
	60 (24)	7	1–16	2	4	2
	150 (59)	7	1–3	2	2	1
	300 (118)	—	—	—	—	—
6 months	Control	4	1–3	2	2	1
	0 (0)	7	2–11	2	3	3
	30 (12)	5	2–2	2	2	2
	60 (24)	5	2–3	2	2	2
	150 (59)	5	2–7	2	3	2
	300 (118)	—	—	—	—	—
11.5 months	Control	4	1–2	1	1	1
	0 (0)	7	2–82	4	15	6
	30 (12)	7	2–27	2	8	4
	60 (24)	7	1–6	3	3	2
	150 (59)	7	1–5	2	2	2
	300 (118)	—	—	—	—	—
	Control	4	2–3	2	2	2

^aUnderlined median and geometric mean values are elevated above background and control levels based on 95% tolerance interval.

^b0 = edge.

60 cm (24 in.) from the platform. Arsenic is generally thought to have greater environmental mobility than does copper or zinc because it is more water soluble and less likely to be adsorbed (Lebow 1996). Moreover, as for copper and zinc, arsenic can be dispersed through the movement of sediment particles during periods of high water flow.

Comparison of Soil and Sediment ACZA Levels

The patterns of ACZA accumulation were very different in soil and sediment. In soil, the ACZA components accumulated very gradually and in low concentrations, until finally increasing more substantially at the 11.5-month inspection. In sediments, elevated levels of ACZA components were detected within 10 days of construction, peaked at 2.5 months after construction, declined at 6 months after construction, and finally increased again 11.5 months after construction.

It is probable that the portions of the columns exposed to standing water released copper and zinc at a faster rate than did their counterparts above the soil that were exposed to leaching only during rainfall. This may explain some of the difference in the soil and sediment accumulation patterns. However, this argument is somewhat flawed because the volume of treated wood exposed in standing water was very small compared to that in the aboveground portions. The vast majority of surface area in each section was exposed to leaching from rainwater only. Copper and zinc concentrations in the sediments were also generally much higher than those detected in soil. This is somewhat surprising, since copper and zinc released into water would be expected to disperse more rapidly to lower levels compared to copper and zinc that drip directly into a localized area of soil. One possible explanation is that a larger volume of wood was used in construction of the boardwalk over the sediments. The platform is wider than the boardwalk, and extensive cross-bracing was employed in construction of the platform. In addition, as previously noted, the galvanized hardware probably contributed substantially to the concentrations of zinc detected in the sediments.

Conclusions From ACZA Studies

Elevated concentrations of copper, zinc and arsenic were detected in some samples removed from rainwater, soil, and sediment adjacent to the ACZA-treated wood. Rainwater collection revealed that although the greatest total release of ACZA components occurred between the 6- and 11.5-month inspections, the rate of release per unit of rainfall peaked within 6 months after construction. Levels of copper, zinc, and arsenic detected in the soil were highest at the 11.5-month inspection, when the geometric means of copper, zinc, and arsenic in samples immediately adjacent to the boardwalk were elevated by approximately 112, 56, and

50 ppm, respectively. The copper, zinc, and arsenic accumulations were localized close to the boardwalk; although samples containing elevated levels of zinc and arsenic were detected as far as 60 cm (24 in.) away, elevated samples were generally found within 30 cm (6 in.) of the boardwalk. In the sediments, elevated levels of ACZA components were detected within 10 days of construction, peaked at 2.5 months after construction, declined at 6 months after construction, and then increased again at the 11.5-month inspection. After 11.5 months, geometric mean copper, zinc, and arsenic levels directly under the edge of the platform were elevated by approximately 56, 89, and 10 ppm, respectively. However, the galvanized hardware appears to have made a major contribution to zinc levels in the sediments, since similar zinc levels were found adjacent to an upstream platform that was treated with a zinc-free preservative. Median and geometric mean concentrations of ACZA components in sediments were generally not elevated more than 60 cm (24 in.) away from the platform, although individual samples occasionally contained elevated levels of zinc as much as 1.5 m (5 ft) away from the treated wood. We found that ACZA-treated wood can cause detectable increases in environmental levels of copper, zinc, and arsenic in very close proximity (generally less than 60 cm (24 in.)) to the treated wood. The areas of accumulation were very localized, even within this distance. The levels of ACZA components released did not cause any significant impact on the quantity or diversity of aquatic insects at the site (see Part II of this report).

ACQ-B Studies

Background Copper Levels

Background concentrations of copper ranged from 24 to 29 ppm in the soil and from 19 to 23 ppm in the sediment and were below 2 ppb in the wetland water.

Rate of Copper Release in Rainfall

Collection and analysis of rainfall from specimens of the ACQ-B-treated decking revealed that the greatest total release of copper occurred between the 2.5- and 6-month inspections (App. IC). If viewed as a function of rainfall, however, the rate of leaching was nearly as high during the initial exposure period and declined substantially during the last exposure period.

The pre-exposure retention of copper in the outer 15 mm of the upper, wide face of the decking was determined by assaying end-matched samples cut from adjacent to the exposure specimens. The average copper retention was 7.4 kg/m^3 (0.46 lb/ft^3), a loading that is 1.7 times higher than that specified for ground-contact retention. (The specified ACQ-B retention was 6.4 kg/m^3 (0.4 lb/ft^3), of which 4.3 kg/m^3 (0.27 lb/ft^3) was copper oxide). Each decking piece was 100% penetrated with preservative and appeared to be somewhat wet. As noted previously, one charge of ACQ-B

material was re-treated and was not inspected for compliance to best management practices (BMPs) prior to shipment.

Because the retention in these five deck boards was much higher than that reported for the charge retention data (Table I-5), a more intensive sampling and analysis of the retention of ACQ-B in the boardwalk was conducted. Samples were removed from the narrow faces of joists, joist headers, columns, and railing. This analysis revealed that the average ACQ-B retention in the outer 15 mm (0.6 in.) varied from 8.6 kg/m³ (0.54 lb/ft³) in the columns to 18.4 kg/m³ (1.15 lb/ft³) in the railings. The overall average ACQ-B retention in the 30 samples removed was 13.6 kg/m³ (0.85 lb/ft³), a value twice the target retention of 6.4 kg/m³ (0.4 lb/ft³) and well above the charge report retention (Table I-5). The over-treatment, and more specifically the re-treatment, of the ACQ-B material probably contributed to the high rate of copper release noted in the rainwater. Release rates would be expected to be lower in material treated to lower retentions.

Accumulation and Mobility of Copper in Soil

Assay zones for soil samples were 0 to 15 cm (0 to 6 in.) (upper zone) and 15 to 30 cm (6 to 12 in.) (lower zone). Copper concentrations are shown in Appendix IC.

As was noted for collection of rainwater from decking specimens (Fig. I-7), the high retention of ACQ-B in the treated wood appeared to have caused a high rate of release and subsequent accumulations in the soil. Elevated copper concentrations were detected in the upper 15 cm (6 in.) of soil adjacent to the ACQ-B treated boardwalk at the first inspection, 10 days after construction (App. IC). The highest concentration (252 ppm) was detected under the edge of the boardwalk, but slightly elevated concentrations were also detected in samples removed 15, 30, and 60 cm (6, 12, and 24 in.) from the boardwalk. Median and geometric mean concentrations were also elevated at each distance from the boardwalk, although the increase was slight for most locations (Table I-21). In the lower assay zone, only one sample was significantly elevated (37 ppm) above background levels, as vertical movement of released copper was apparently limited in the first 10 days (Table I-21, App. IC).

Copper concentrations detected in the samples increased slightly at the 2.5-month inspection. Once again, the maximum concentration (288 ppm) was detected under the edge of the boardwalk. The median and geometric mean copper concentrations under the edge of the boardwalk increased substantially, to 144 and 150 ppm, respectively. The median and geometric concentrations also increased slightly at 15, 30, and 60 cm (6, 12, and 24 in.) from the boardwalk, but remained much lower than concentrations under the edge of the boardwalk.

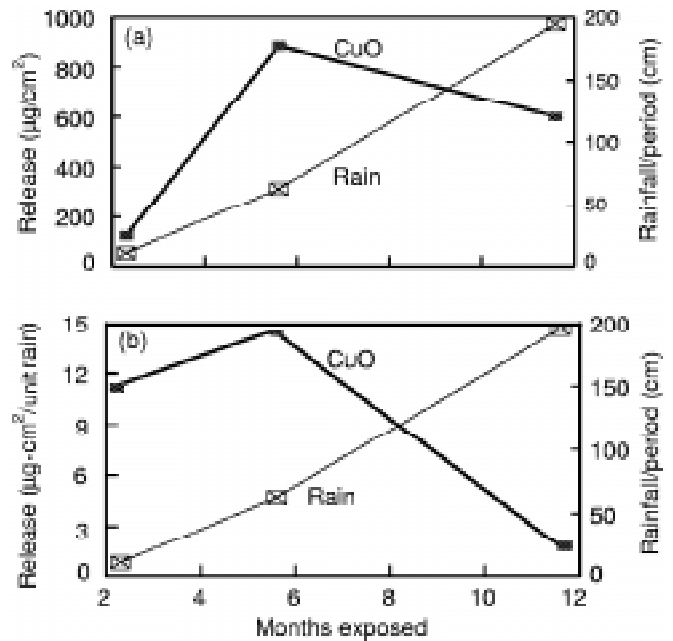

Figure I-7—Release of copper into rainwater collected from ACQB-treated decking. Rate of release expressed as (a) µg/cm² and (b) µg·cm²/unit rain. 1 unit = 22.54 cm (1 in.).

A substantial increase in soil copper concentrations occurred between the 2.5- and 6-month inspections, a period that included heavy Autumn rains at the site. Maximum copper concentrations of 2,158 and 1,943 ppm were detected in the upper 15 cm (6 in.) of samples removed from under the edge of the boardwalk, and the median and geometric mean increased to 281 and 399 ppm, respectively. Two samples removed from under the edge of the boardwalk also contained elevated levels (52 and 73 ppm) in the lower assay zone. Increases in maximum, median, and geometric mean copper concentrations in the upper 15 cm (6 in.) of soil samples were also noted in samples removed 15 cm (6 in.) from the boardwalk, although the increases at this distance were less dramatic. Interestingly, concentrations detected in the upper 15 cm of samples removed 30 and 60 cm (12 and 24 in.) from the boardwalk actually declined slightly during this period. None of the samples removed 15, 30, or 60 cm (6, 12, or 24 in.) from the boardwalk contained elevated copper concentrations in the lower assay zone.

At the 11.5-month inspection, copper levels in the upper 15 cm of samples removed from under the edge of the boardwalk appeared to have stabilized. The maximum and geometric mean concentrations declined slightly, although the median concentration increased to 400 ppm. Copper concentrations in the lower assay zone did increase; a maximum of 434 ppm was detected and the median and geometric mean concentrations increased to 68 and 91 ppm, respectively. Copper concentrations also increased in the upper assay zone of samples removed at greater distances from the boardwalk. Six of the seven samples removed at

Table I-21—ACQ-B: Copper concentrations in soil samples^a

Time of sampling	Distance from boardwalk ^b (cm (in.))	Sample size	Range (ppm)	Median (ppm)	Mean (ppm)	Geometric mean (ppm)
Upper 15 cm (6 in.) of soil						
Preconstruction	Intended path	21	24–29	26	26	26
0.3 months	0 (0)	6	45–252	<u>70</u>	103	<u>83</u>
	15 (6)	7	30–45	<u>34</u>	35	<u>34</u>
	30 (12)	7	27–48	<u>34</u>	35	<u>34</u>
	60 (24)	7	28–38	<u>31</u>	32	<u>32</u>
2.5 months	Control	4	23–27	24	25	25
	0 (0)	7	58–288	<u>144</u>	168	<u>150</u>
	15 (6)	6	30–52	<u>35</u>	39	<u>38</u>
	30 (12)	6	25–58	<u>38</u>	39	<u>38</u>
6 months	60 (24)	6	31–44	<u>36</u>	37	<u>36</u>
	Control	4	20–24	21	22	22
	0 (0)	6	106–2158	<u>281</u>	815	<u>399</u>
	15 (6)	7	33–164	<u>69</u>	53	<u>50</u>
11.5 months	30 (12)	7	27–206	<u>60</u>	37	<u>36</u>
	60 (24)	7	20–35	27	26	26
	Control	4	25–28	25	18	18
	0 (0)	7	49–1894	<u>400</u>	560	<u>343</u>
	15 (6)	7	33–164	<u>68</u>	82	<u>73</u>
	30 (12)	7	27–206	<u>60</u>	80	<u>64</u>
	60 (24)	7	26–66	<u>42</u>	44	<u>42</u>
	Control	4	25–26	25	25	25
Lower 15–30 cm (6–12 in.) of soil						
Preconstruction	Intended path	21	19–27	22	23	23
0.3 months	0 (0)	6	22–37	28	29	<u>29</u>
	15 (6)	7	22–25	23	23	23
	30 (12)	7	21–24	23	23	23
	60 (24)	7	24–26	25	25	25
2.5 months	Control	4	22–24	23	23	23
	0 (0)	—	—	—	—	—
	15 (6)	—	—	—	—	—
	30 (12)	—	—	—	—	—
6 months	60 (24)	6	22–28	24	24	24
	Control	—	—	—	—	—
	0 (0)	7	22–73	30	37	<u>34</u>
	15 (6)	5	22–27	23	24	24
11.5 months	30 (12)	5	22–26	22	23	23
	60 (24)	7	21–24	22	22	22
	Control	4	16–24	21	21	21
	0 (0)	4	34–434	<u>68</u>	151	<u>91</u>
	15 (6)	7	19–86	24	33	29
	30 (12)	7	21–39	22	26	25
	60 (24)	7	21–30	23	23	23
	Control	3	20–23	23	22	22

^aUnderlined median and geometric mean values are elevated above background and control levels based on 95% tolerance interval.

^b0 = dripline.

30 cm (6 in.) from the boardwalk and five of seven samples removed at 60 cm (24 in.) contained elevated copper concentrations.

Although copper release from the boardwalk and subsequent accumulation was apparently greatly diminished by 11.5 months after construction, copper movement outward and downward in the soil has continued. Copper has evidently moved at least 60 cm (24 in.) away from the boardwalk. This might be expected, based on the very sharp gradient of copper concentration in the soil observed at the 6-month inspection. Given the high levels of copper detected in the upper 15 cm (6 in.) of soil immediately under the edge of the boardwalk, it is remarkable that higher copper concentrations were not detected at greater distances from the boardwalk.

The upper 15 cm (6 in.) of soil at the ACQ-B test site is classified as silt loam; it contains 42.8% sand, 51.2% silt, and 6.0% clay and has a cation exchange capacity (CEC) of 32.1 meq. The relatively high silt content and CEC of the soil may have provided reactive sites that limited copper movement downward through the soil. Horizontal copper movement may have been slightly greater during puddling of rainwater on the soil surface.

Accumulation and Mobility of Copper in Sediment

Assay zones for sediment samples were 0 to 2.5 cm (0 to 1 in.) (upper zone) and 2.5 to 10 cm (1 to 4 in.) (lower zone). Copper concentrations in the upper 2.5 cm (1 in.) of sediment were slightly elevated in approximately one-third of samples removed 10 days after construction (App. IC). Unlike the soil samples, the highest accumulations in the sediment were not concentrated under the edge of the platform but instead were found at all distances evaluated (except controls). The highest level detected (76 ppm) was in a sample removed 60 cm (24 in.) from the boardwalk. The overall accumulations were slight, although the geometric mean copper concentration was elevated at each distance from the wood (Table I-22). Because the elevated samples were widely dispersed, the median concentration was not elevated at any distance from the treated wood. None of the samples contained elevated levels of copper in the lower assay zone (Table I-22, App. IC).

At the August inspection, 2.5 months after construction, slightly higher copper concentrations were detected in the upper 2.5 cm (1 in.) of samples removed from under the edge of the platform, but little increase was observed further from the boardwalk. Between the 10-day and 2.5-month (August) inspections, water levels at the site receded until water no longer contacted the treated wood. This may have lessened the release of copper and/or limited its dispersal in the wetland. Again, none of the samples contained elevated levels of copper in the lower assay zone.

At the 6-month inspection, sizable increases in copper concentrations were detected in the upper 2.5 cm (1 in.) of samples removed from adjacent to the platform. The greatest increases were again noted under the edge of the boardwalk, where a maximum of 427 ppm was detected in one sample, and the median and geometric mean were increased to 77 and 113 ppm, respectively. Increases were also noted at greater distances from the treated wood, especially in the frequency of elevated samples. Median and geometric copper concentrations increased at all distances evaluated (except the controls). Occasional elevation of concentration was also noted in the lower assay zone, although the frequency and intensity of elevation in the samples was less than that in the upper assay zone.

As was noted for soil samples, sediment levels of copper appeared to have stabilized by the 11.5-month inspection. Maximum and geometric mean copper concentrations in the upper 2.5 cm (1 in.) of samples removed from under the edge of the boardwalk declined slightly, although the median concentration increased slightly. Copper concentrations also declined slightly in the upper assay zone of samples removed at 0.3, 0.60, and 1.5 m (1, 2, and 5 ft) from the boardwalk. At this inspection, samples were removed at a greater distance (3 m (10 ft)) from the platform, and 3 of the 7 samples contained elevated copper concentrations. The decline in copper concentrations nearer the boardwalk, combined with the finding of elevated samples at 3 m (10 ft) from the boardwalk, indicates that although release of copper from the wood had greatly diminished, portions of the previous accumulations had been dispersed from the site by high water or beaver activity. Elevated copper concentrations were again detected in the lower assay zone of a few samples, but copper accumulations were generally confined to the upper 2.5 cm (1 in.) of sediment.

It is evident that copper released from the ACQ-B-treated platform accumulated in sediments at least 3 m (10 ft) away from the treated wood. The overtreatment of the wood and subsequent high release rate of copper probably contributed to this effect. Release and accumulation of copper in the sediments has apparently peaked, but further copper movement away from the wood is possible. The quantity of fine sediments at the site suggests that the majority of copper released from the wood rapidly becomes associated with sedimentary material. Further mobility is likely to occur primarily when the sediments themselves are dislodged by high water or other types of disturbances.

Comparison of Soil and Sediment Copper Levels

Copper concentrations near the boardwalk were generally higher and more localized in soil than in sediment. This might be expected because copper released into water would be more rapidly dispersed to lower levels compared with copper that drips directly into a localized area of soil.

Table I-22—ACQ-B: Copper concentrations in sediment samples^a

Time of sampling	Distance from boardwalk ^b (cm (in.))	Sample size	Range (ppm)	Median (ppm)	Mean (ppm)	Geometric mean (ppm)
Upper 2.5 cm (1 in.) of sediment						
Preconstruction 0.3 months	Intended path	10	19–23	20	21	21
	0 (0)	7	23–46	29	30	<u>29</u>
	30 (12)	7	20–39	27	28	<u>27</u>
	60 (24)	7	21–76	27	36	<u>32</u>
	150 (59)	7	21–40	24	29	<u>28</u>
	300 (118)	—	—	—	—	—
2.5 months	Control	4	18–25	21	21	21
	0 (0)	7	25–139	<u>34</u>	49	<u>41</u>
	30 (12)	7	21–49	33	32	<u>31</u>
	60 (24)	6	18–30	24	24	23
	150 (59)	7	23–35	25	27	<u>27</u>
	300 (118)	—	—	—	—	—
6 months	Control	4	18–22	20	20	20
	0 (0)	7	45–427	<u>77</u>	163	<u>113</u>
	30 (12)	7	23–183	<u>52</u>	81	<u>63</u>
	60 (24)	7	28–78	<u>47</u>	50	<u>47</u>
	150 (59)	7	31–74	<u>51</u>	50	<u>48</u>
	300 (118)	—	—	—	—	—
11.5 months	Control	4	17–22	19	19	19
	0 (0)	7	52–122	<u>90</u>	89	<u>86</u>
	30 (12)	7	31–114	<u>45</u>	56	<u>52</u>
	60 (24)	7	24–98	<u>36</u>	48	<u>43</u>
	150 (59)	7	22–75	<u>37</u>	43	<u>39</u>
	300 (118)	7	22–65	30	34	<u>32</u>
	Control	10	15–24	20	20	20
Lower 2.5–10 cm (1–4 in.) of sediment						
Preconstruction 0.3 months	Intended path	10	19–23	20	21	21
	0 (0)	7	20–27	23	23	23
	30 (12)	7	19–25	21	21	21
	60 (24)	7	20–29	22	23	23
	150 (59)	7	15–26	23	22	21
	300 (118)	—	—	—	—	—
2.5 months	Control	4	22–23	23	23	23
	0 (0)	6	18–27	22	22	21
	30 (12)	7	18–26	22	22	22
	60 (24)	7	19–24	21	21	21
	150 (59)	7	17–37	22	23	22
	300 (118)	—	—	—	—	—
6 months	Control	4	14–23	19	19	18
	0 (0)	7	19–166	24	53	<u>28</u>
	30 (12)	7	19–31	23	24	23
	60 (24)	7	19–26	23	23	22
	150 (59)	7	18–23	22	21	21
	300 (118)	—	—	—	—	—
11.5 months	Control	4	17–26	22	22	22
	0 (0)	7	23–132	<u>33</u>	49	<u>41</u>
	30 (12)	6	20–31	22	23	23
	60 (24)	7	18–54	21	26	24
	150 (59)	7	18–33	25	24	24
	300 (118)	7	17–36	21	24	23
	Control	10	19–23	20	20	20

^aUnderlined median and geometric mean values are elevated above background and control levels based on 95% tolerance interval.

^b0 = edge.

Copper attached to sediments could also be more readily spread by any activity that transports the sediment from one area to another. In both soil and sediment, copper levels appeared to peak at the 5.5-month inspection, although further movement away from the boardwalk has continued.

Conclusions From ACQ–B Studies

Elevated levels of copper were detected in rainwater, soil, and sediment collected from adjacent to the treated wood. The rainwater collection indicated that release of copper peaked by 6 months after construction, reaching an average release rate of 35 $\mu\text{g}/\text{cm}^2/\text{unit rain}$. (One unit = 25.4 cm (1 in.)) A much lower average release rate (approximately 5 $\mu\text{g}/\text{cm}^2/\text{unit rain}$) was observed by 11.5 months after construction. The relatively high release of copper during the first 6 months of the study were reflected in the concentrations of copper detected in the soil; geometric mean soil concentrations were elevated by approximately 373 ppm directly under the edge of the boardwalk. However, copper accumulations were localized in soil very close to the boardwalk; the geometric mean concentration was elevated by only 16 ppm at 60 cm (24 in.) from the boardwalk. Sediment copper concentrations also appeared to peak at about 6 months, when the geometric mean of samples removed from directly under the edge of the boardwalk reached 113 ppm, an elevation of approximately 92 ppm over background levels. Copper mobility in the sediment was greater than that in the soil, causing slight elevations in three samples removed 3 m (10 ft) from the boardwalk 11.5 months after construction.

The results of this study demonstrate the potential for significant accumulations of copper in soil, sediment, and water immediately adjacent to ACQ–B-treated wood. However, this study can truly be considered a worst-case scenario since the boardwalk decking appeared to be over-treated and inadequately conditioned; smaller releases of copper might be expected from material treated to a retention more appropriate for this application. Despite the accumulations of copper detected in the environment, a companion study did not detect any significant impact on the quantity or diversity of aquatic insects at the site (see Part II of this report).

CDDC Studies

Background Copper Levels

Background copper concentrations at the CDDC site were relatively uniform, ranging from 19 to 31 ppm in the top 0 to 15 cm (0 to 6 in.) of soil and 21 to 35 ppm in the lower 15 to 30 cm (6 to 12 in.) of soil (Table I–23, App. IC).

Accumulation and Mobility of Copper in Soil

Assay zones used for soil samples were 0 to 15 cm (0 to 6 in.) (upper zone) and 15 to 30 cm (6 to 12 in.) (lower

zone). Concentrations of CDDC components in individual samples are shown in Appendix IC.

At the first postconstruction sampling, the majority of samples removed from the top 15 cm (6 in.) of soil did not contain elevated copper concentrations. However, copper concentrations of 46 and 49 ppm were detected in two samples removed at zero distance from the edge of the boardwalk (App. IC). None of the samples removed from 15 to 30 cm (6 to 12 in.) below the soil surface appeared to contain elevated copper levels (App. IC), and median and geometric mean concentrations were not elevated at any distance from the boardwalk for either assay zone (Table I–23). Approximately 2 cm (0.8 in.) of rainfall were recorded during this period (Table I–6).

Two months after construction, elevated maximum, median, and geometric mean levels of copper were detected in samples in the upper 15 cm (6 in.) of soil removed at zero distance from the edge of the boardwalk (Table I–23). The highest level of copper detected was 105 ppm. Little elevation in copper was noted further away from the boardwalk; one sample had a very slightly elevated copper level at 15 cm (6 in.) from the boardwalk. No elevated copper concentrations were detected in the lower assay zone (Table I–23). Approximately 9 cm (3.5 in.) of rain fell between the 2- and 5.5-month inspections.

Copper concentrations in the top 15 cm of soil at zero distance from the boardwalk increased slightly once again during the 2- to 5.5-month period; the maximum level detected was 120 ppm, and the median and geometric mean increased to 38 and 47 ppm, respectively. Eight of the 15 samples removed at zero distance appeared to contain elevated copper levels in the upper assay zone. In addition, one sample removed at zero distance contained 54 ppm copper in the lower assay zone. Slight copper movement away from the boardwalk was also detected; one sample 15 cm (6 in.) from the boardwalk contained 41 ppm copper in the upper assay zone. Substantial rainfall (56 cm (22 in.)) occurred during the interval between the 2- and 5.5-month sampling periods.

At 11 months after construction, copper levels in the top 15 cm of soil at zero distance from the boardwalk increased greatly compared to concentrations detected at the 5.5-month inspection. The maximum level detected was increased to 620 ppm, and the geometric mean and median concentrations were increased to 155 and 153 ppm, respectively (Table I–23). The highest copper levels were all found on one side of the boardwalk (App. IC), suggesting that a slight slope in the boardwalk directed run-off in that direction. Elevated copper concentrations were also detected in the lower assay zone of some samples removed 0 and 15 cm (0 and 6 in.) from the boardwalk. Although the increases were much less than those in the upper assay zone, the geometric mean copper concentrations were elevated within 15 cm (6 in.) of the boardwalk (Table I–23).

Table I-23—CDDC: Copper concentrations in soil samples^a

Time of sampling	Distance from boardwalk ^b (cm (in.))	Sample size	Range (ppm)	Median (ppm)	Mean (ppm)	Geometric mean (ppm)
Upper 15 cm (6 in.) of soil						
Preconstruction	Intended path	26	19–31	26	25	25
0.5 months	0 (0)	15	22–49	28	30	29
	15 (6)	15	22–28	25	25	25
	30 (12)	15	22–29	26	26	26
	60 (24)	15	23–35	27	27	27
2 months	Controls	4	23–33	28	28	27
	0 (0)	15	24–105	<u>34</u>	38	<u>35</u>
	15 (6)	15	23–35	25	26	26
	30 (12)	15	20–29	24	24	24
5.5 months	60 (24)	15	19–33	23	24	24
	Controls	4	21–24	23	23	23
	0 (0)	15	21–120	<u>38</u>	53	<u>47</u>
	15 (6)	15	21–41	28	28	28
11 months ^c	30 (12)	15	19–29	22	23	23
	60 (24)	15	22–32	26	26	26
	Controls	4	19–30	22	23	23
	0 (0)	15	29–620	<u>153</u>	213	<u>155</u>
	15 (6)	15	23–90	<u>34</u>	41	<u>38</u>
	30 (12)	15	23–35	<u>29</u>	30	<u>30</u>
	60 (24)	15	24–33	28	28	28
	Controls	4	23–30	24	25	25
Lower 15–30 cm (6–12 in.) of soil						
Preconstruction	Intended path	22	21–35	27	27	27
0.5 months	0 (0)	8	21–30	27	27	26
	15 (6)	12	24–31	26	26	26
	30 (12)	9	24–31	28	27	27
	60 (24)	12	26–32	28	29	28
2 months	Controls	3	25–32	28	28	28
	0 (0)	12	23–31	26	26	26
	15 (6)	12	23–31	27	27	27
	30 (12)	10	23–31	27	28	27
5.5 months	60 (24)	11	22–31	27	27	27
	Controls	2	26–33	29	29	29
	0 (0)	14	22–54	29	29	29
	15 (6)	10	21–31	24	25	25
11 months ^c	30 (12)	7	21–25	23	23	23
	60 (24)	14	22–34	28	28	28
	Controls	2	26–32	26	26	25
	0 (0)	14	23–89	<u>35</u>	46	<u>42</u>
	15 (6)	14	22–52	32	34	<u>33</u>
	30 (12)	13	22–37	27	27	27
	60 (24)	13	22–31	26	26	26
	Controls	2	31–33	32	32	32

^aUnderlined median and geometric mean values are elevated above background and control levels based on 95% tolerance interval.

^b0 = dripline.

^cConcentrations at this sampling may have been elevated by application of sand to the walkway.

Interpretation of copper levels found at the 11-month inspection is complicated because sand was applied to the walkway between the 5.5- and 11-month inspections. This may have caused abrasion and released wood particles into the soil as people walked on the boardwalk. An assay of sand collected from the walkway at the 11-month inspection revealed that the sand contained 104 ppm copper. Although this level is lower than the copper concentrations detected in some soil samples, it does indicate that sand was releasing wood particles from the decking. Small wood particles would be expected to release copper much more readily than would lumber because of the large surface area to volume ratio of small particles, and the particles themselves could have easily been washed into the soil. The rigorous acid digestion process used in analyzing the soil samples would not have differentiated between copper that had been leached from the decking and copper still contained within wood particles. On the other hand, the extensive rainfall (approximately 208 cm (80.7 in.)) that occurred between the 5.5- and 11-month inspections (Table I-6) probably also contributed to increased leaching of copper from the treated wood. The high copper levels immediately adjacent to the edge of the boardwalk were apparently due to a combination of leaching and abrasion, but the relative contribution of each mechanism could not be determined. These findings indicate that discretion should be used in applying sand to the surfaces of treated wood walkways.

Considering the copper levels detected immediately adjacent to the boardwalk, it is remarkable that the highest copper level detected just 15 cm (6 in.) from the boardwalk was only 90 ppm and that no elevated levels were detected 30 cm (12 in.) from the boardwalk. Even in the lower assay zone of samples removed at zero distance from the boardwalk, the highest copper level detected was 89 ppm. Again, this may indicate that much of the copper detected in the upper assay zone was in the form of wood particles deposited on top of the ground.

The soil adjacent to the CDDC boardwalk is classified as a "gravelly sandy loam," with a composition of 54.8% sand, 37.1% silt, and 8.2% clay (these percentages do not include objects larger than 2 mm (gravel), which were numerous at the site) and a cation exchange capacity of 31.4 meq. The soil is fairly porous and thus might have been expected to allow greater downward copper movement than was detected. However, that same porosity minimized ponding or puddling on the soil surface and thus did not allow rapid horizontal movement of copper over the surface of the ground.

Conclusions From CDDC Studies

During the first three postconstruction inspections, copper concentrations immediately adjacent to the boardwalk slowly increased. By 5.5 months after construction, the average copper level in the top 15 cm of soil was only 28 ppm higher

than the average preconstruction level. This trend changed at the 11-month inspection, when the combination of sand applied to the walkway and heavy rainfall increased geometric mean soil copper levels immediately adjacent to the boardwalk to a level approximately 135 ppm higher than preconstruction levels. It is likely that much of the increase in soil copper levels during this period was due to removal of wood particles by abrasion and that levels would have been lower if sand had not been applied to the boardwalk. Nevertheless, the results suggest that sand should not be applied to CDDC-treated wood (or probably other types of treated wood) in areas where release of copper into the environment is a concern.

Soil movement of copper was apparently quite limited; during the course of the study, only a few samples removed 15 cm (6 in.) from the boardwalk contained elevated levels of copper, and the maximum copper concentration detected at greater distances from the wood was 37 ppm. Copper movement downward in the soil was also quite limited; the vast majority of copper leached was confined within the top 15 cm (6 in.) of soil. Thus, any environmental contamination is apparently restricted to immediately adjacent to the wood when CDDC-treated wood is used in or over soil.

General Results and Discussion

Mobility of Preservative Components in Wetland

Elevated environmental concentrations of preservative components were detected at all test sites, but elevated samples were generally located in close proximity to the treated wood. This was especially true for the portions of structures built over soil. Past studies also indicated that chromium, copper, and arsenic leached from preservative-treated wood have limited mobility in soil. Bergholm (1992) covered CCA-treated wood chips with three different types of soil and analyzed losses caused by precipitation. Arsenic and chromium were found to be more mobile in fine sand soil than in clay or marsh peat soils, while copper movement was highest through marsh peat soil. The increased copper leaching and mobility from chips exposed in the marsh peat soil was attributed to copper complexation with soluble organics. In general, all three soils retained CCA components quite well; less than 1% of elements lost from the wood chips moved out of the soil columns after 11 years.

Other studies of movement of leached copper, chromium and arsenic in soils generally agree that although the constituents are not highly mobile, significant movement of arsenic may occur in sandy soils (Bergholm 1990, Bergholm and Dryler 1989, Bergman 1983, Brown 1986, Chen and Walters 1979, De Groot and others 1979, Holland and Orsler 1995, Lund and Fobian 1991, Murphy and Dickinson 1990). In a recent study, Holland and Orsler (1995) evaluated the ability of various soil types to adsorb CCA components from a 3%

solution. They found that a sandy, free-draining soil adsorbed very little of any CCA component, while sphagnum peat, containing 98% organic material, readily adsorbed all three CCA components. Two loam-clay soils evaluated adsorbed copper and arsenic but very little chromium, while a third loam-clay soil adsorbed only arsenic, to a lesser degree than adsorbed by the other loam-clay soils. The authors concluded that although a high organic content was generally associated with the capability to adsorb all three CCA components, other factors such as pH or inorganic constituents must also play a role (Holland and Orsler 1995). The relatively poor adsorption of chromium found in that study is somewhat surprising, and it should be noted that although the concentrations of CCA components exposed to the soil in that test may simulate the conditions of a spill at a treating plant, they were many times greater than would result from CCA leaching in service.

The arsenic adsorption results found by Holland and Orsler (1995) generally agree with those from studies of contaminated soils around treating plants, in which the highest levels of arsenic were retained in the soils with high levels of clay or organic matter (Bergholm 1990, Bergholm and Dryer 1989, Bergman 1983). Another study of copper, chromium, and arsenic contaminated soils in Denmark also reported that virtually all the chromium and the majority of copper and arsenic were deposited within the first 250 mm (9 in.) of soil, the area high in organic carbon (Lund and Fobian 1991). A similar Swedish study reported that elevated arsenic, copper, and chromium levels were found only in the top 100 to 400 mm (4 to 18 in.) of contaminated soil and that levels were highest in soils with a high proportion of organic material (Bergman 1983). A more recent Swedish study reported that the retention capacity of arsenic in fine sand was approximately 100 ppm, while that in clay soil was about 500 ppm and in marsh peat soil about 5,000 ppm (Bergholm and Dryer 1989).

Little, if any, data have been published on the soil mobility of zinc released from preservative-treated wood, but research has addressed the movement of naturally occurring zinc. The mobility of zinc in soil is limited by precipitation and sorption processes. One study reported that zinc in soils has a 30% to 60% association with manganese and iron oxides and a 20% to 45% association with the clay fraction (Bodek and others 1988). Zinc also reacts with soil constituents through cation exchange reactions, with ligands in humic matter and clay providing reactive sites. Zinc also forms chelates with organic acids, although these complexes have much less stability than those formed by copper (Alloway 1990). Some of these complexes may be soluble, preventing the adsorption or precipitation of zinc as it moves through soil or water. Although not as strongly adsorbed as copper, zinc also undergoes specific adsorption reactions with soil components beyond those that would result from simple cation exchange reactions (Alloway 1990).

Although the preservative elements are readily adsorbed or precipitated by soil components, the availability of reactive sites within the soil is limited. In our study, because high levels of copper, and to a lesser extent zinc and arsenic, have accumulated immediately adjacent to the boardwalk in some areas, some further movement of these elements outward from the boardwalk will likely occur as these high concentrations diffuse. However, because the rate of preservative release has greatly slowed, lessening further accumulations immediately adjacent to the boardwalk, there will be a diminishing pool of leached components that are not tightly bound to soil components.

Greater movement of leached components in the wetland was noted from the portions of treated structures that were constructed over standing water. This might be expected because the components leached into water have greater opportunity for dispersion before contacting materials that cause them to be adsorbed or precipitated. Adsorption reactions with inorganic and organic compounds in water and sediments greatly affect the solubility and mobility of leached preservative components. Copper deposited in sediments is usually complexed with organics or precipitated with inorganic oxides (Messure and others 1991). The two primary classes of organic compounds responsible for the adsorption of copper appear to be the humic and fulvic acids (Giesking 1975, Stevenson and Fitch 1981, Tan 1993). Copper may also be adsorbed by inorganics, such as manganese oxides, and clay minerals (Baker 1990). Based on previous studies, chromium, like copper, appears to be relatively immobile in the environment (Lebow 1996). The resistance of chromium to leaching and its limited environmental movement is a result of the ability of trivalent chromium to form stable, inert complexes with a wide range of organic and inorganic ligands. Arsenic is generally thought to have greater environmental mobility than does copper or chromium because it is more water soluble and less likely to be adsorbed. Arsenic reactivity in water and sediments is most strongly related to inorganic constituents; iron oxide, aluminum, calcium, and clay minerals are important in binding arsenic (Fordham and Norrish 1974, Frost and Griffin 1977, Walsh and Keeney 1975). In sediments, arsenic oxyanions can also form complexes with the sulfur produced by decomposition of organic matter. Microorganisms can also affect the mobility and fate of arsenic when it enters the environment. A variety of fungi and bacteria are known to convert inorganic arsenic to more soluble and mobile methylated species (O'Neill 1990).

Zinc is potentially one of the most mobile of heavy metals in wetlands because it commonly forms complexes with ligands that are soluble in both neutral and acid waters (Bodek and others 1988). At higher pH levels, the formation of $Zn(OH)_2$ greatly increases the solubility of zinc (up to approximately 160 ppm), even without considering the effect of water-soluble ligands. However, other factors work to lower the concentration of zinc in water. In reducing conditions, zinc

sulfide precipitates may form, while in oxidizing conditions precipitation as $ZnCO_3$ or $Zn(OH)_2(SO_4)$ can occur. In addition, sorption to insoluble ligands such as iron and manganese oxides and organic matter can lower the zinc concentration in natural waters.

Most of the zinc introduced into aquatic environments is eventually partitioned into the sediments through the precipitation and sorption reactions mentioned in the previous text. As with copper, higher levels of zinc are found in sediments with smaller grains (Bodek and others 1988). However, much less of zinc in sediments is bound to organic matter than is the case with copper. Less than 5% of the zinc in sediments is estimated to be bound to organic matter (Bodek and others 1988). Zinc bioavailability from sediments is increased under conditions of high dissolved oxygen, low salinity, and low pH, and when high levels of inorganic oxides and humic substances are present (Eisler 1993).

Further mobility of leached metals that have precipitated into the sediments may occur if the sediments themselves are displaced. This may occur through the activities of wildlife such as beaver (which are common at our study site) or through displacement during high water. However, little, if any, sediment disturbance was observed during a high water event in November 1996.

Evaluation of Durability

As expected, no significant degradation occurred in any type of treated wood or the untreated wood within the exposure period. A longer exposure time will be needed to fully assess the durability benefits derived from the use of various types of treated wood in this environment. Attack by decay fungi was not evident in treated or untreated wood. However, the sapwood portions of untreated Douglas-fir were heavily colonized by stain and mold fungi. Growth of white mold was also observed on many vertical surfaces of CDDC-treated wood. The CDDC-treated Southern Pine decking surface was notably more slippery than were the surfaces of other types of treated wood. It is unclear whether this is a function of the wood preservative, the wood species, or the absence of incising in the Southern Pine. The Western Hemlock and Douglas-fir treated with other preservatives were incised, which adds a slight texture to the wood surface.

Although wood-plastic composite lumber was not included within the study sections, along the main boardwalk trail the hand rails made with wood-plastic composite lumber showed substantial attack by a variety of molds and lichens in shaded portions of the trail. Discoloration was much more notable than that on even the untreated Douglas-fir. Some bowing or sagging of plastic composite lumber was also observed in the portions of the trail exposed to direct sunlight. This problem was especially visible from the vantage point of a long, straight section of the trail.

Evaluation of Corrosion

In-Service Boardwalk Fasteners

Corrosion was apparent in the joist hangers used for construction of the ACQ-B section after only 2.5 months. Within 6 months, many joist hangers in the ACQ-B sections were covered by rust. It is probable that the ACQ-B-treated wood was not properly dried before construction of the boardwalk, and the resulting high ammonia content contributed to rapid corrosion. We had expected that the corrosion rate for ACQ-B-treated wood would be similar to that of wood treated with ACZA, since both preservatives are ammoniacal copper systems. However, fasteners in the ACZA-treated wood, which was kiln dried after treatment, contained only a few isolated rust spots, as did fasteners in the CDDC section. Fasteners in the CCA-C section showed little, if any, rust. All the hangers were electroplated "off the shelf" products intended for use outdoors, but they were coated with only about one-third of the zinc used on hot-dipped hardware. The bolts, nuts, and washers used in construction were hot-dipped galvanized hardware.

Bolts in Small Specimens

Corrosion of the bolts in small specimens treated with ACQ-B was much less significant than that observed in the actual boardwalk. This is probably because the smaller ACQ-B-treated samples and other treated wood samples were air dried before test bolts were installed. Substantial rust was nevertheless observed in the washers and bolts of electroplated fasteners installed in the ACQ-B- and ACZA-treated wood exposed above ground. The general appearance of the hot-dipped galvanized bolts installed in the ACQ-B-treated wood was slightly worse than that of the bolts installed in the ACZA-treated wood; much of the zinc coating had disappeared. However, the rust was not sufficient to measurably reduce the weights or dimensions of the bolts. Some spots of rust were also observed in electroplated bolts installed in the untreated and CCA-C-treated wood, but the hot-dipped bolts placed in these types of wood were in good condition. In all cases, the stainless steel bolts were completely free of rust or corrosion. When constructing with any of these types of treated wood, either hot-dipped galvanized or stainless steel fasteners should be used to ensure satisfactory performance.

Summary

This study evaluated the release and environmental mobility of four types of waterborne wood preservatives when the treated wood was exposed in conditions that presented a severe leaching hazard. All types of wood preservatives evaluated in this study measurably increased concentrations of preservative elements in the surrounding soil and sediment. Concentrations were generally more elevated in soil than sediment samples, although relatively little accumulation of CCA-C components was detected in soil surrounding

the CCA-C-treated viewing platform. At that site, arsenic was the most elevated in the soil; in one sample, arsenic was elevated by approximately 30 ppm. Higher levels of CCA-C components were detected in sediment adjacent to the CCA-C-treated boardwalk. The geometric mean of copper levels in samples removed from directly underneath the boardwalk reached a maximum of 98 ppm, an elevation of approximately 76 ppm above the background level. Chromium and arsenic geometric mean concentrations were elevated by a maximum of approximately 21 and 35 ppm, respectively, in samples removed from underneath the boardwalk.

Levels of copper, zinc, and arsenic detected in the soil surrounding the ACZA-treated section were highest at the 11.5-month inspection, when the geometric means of copper, zinc, and arsenic in samples removed from immediately adjacent to the boardwalk were elevated by approximately 112, 56, and 50 ppm, respectively. In the sediment directly under the ACZA-treated platform, the geometric mean copper, zinc, and arsenic levels were elevated by approximately 56, 89, and 10 ppm, respectively, after 11.5 months. However, the galvanized hardware appears to be making a major contribution to zinc levels in the sediments, since similar zinc levels were found adjacent to the platform treated with ACQ-B.

The ACQ-B-treated wood exhibited a relatively high release of copper during the first 6 months of the study, which was reflected in the concentrations of copper detected in the soil; geometric mean soil concentrations were elevated by approximately 373 ppm directly under the edge of the boardwalk. Sediment copper concentrations also appeared to peak at about 6 months, when the geometric mean of samples removed from directly under the edge of the boardwalk reached 113 ppm, an elevation of approximately 92 ppm over background levels.

During the first three postconstruction inspections, copper concentrations in soil immediately adjacent to the CDDC-treated boardwalk slowly increased to geometric mean levels approximately 20 ppm above background concentrations. This trend changed at the 11-month inspection, when the combination of sand applied to the walkway and heavy rainfall increased geometric mean soil copper levels immediately adjacent to the boardwalk to a level approximately 130 ppm higher than preconstruction levels.

For all preservatives, samples containing elevated concentrations of preservative components were largely confined to within 30 cm (12 in.) of the treated wood in soil and within 60 cm (24 in.) of the treated wood in sediment. Analysis of rainwater collected from treated wood samples revealed that the highest rate of leaching occurred at the beginning of the study and declined substantially after 6 months. Because of the conditions at the site (that is, large quantity of rainfall, large volume of treated wood, stagnant standing water), these data probably represent the upper end or "worst case" of the

range of preservative release rates and environmental accumulation for most treated wood applications.

Although the four preservatives used in our study showed great differences in the rates of release and environmental accumulation of their components, direct comparisons between these preservatives are inappropriate. The exposure times and conditions were not identical, different wood species were used, and preservative penetration, preservative retention, and post-treatment conditioning varied. It is particularly notable that one charge of ACQ-B-treated material was re-treated and was not subsequently inspected for compliance with best management practices (BMPs). Observations during construction indicated that much of the ACQ-B-treated decking was heavily treated and lacked adequate post-treatment conditioning. Although the purpose of the study was to evaluate "realistic worst case" conditions, the study was not intended to evaluate the effect of less than desirable treating practices. Leaching from all the types of preservative-treated wood can be influenced by treatment and conditioning practices, and it is probable that releases from the ACZA-, CCA-C-, and CDDC-treated material would have been greater if substandard treating practices had been employed. This point is raised to emphasize the importance of specifying that wood intended for use in sensitive environments be produced in accordance with BMPs such as those published by the Western Wood Preservers' Institute.

Monitoring of preservative accumulation in the wetland surrounding the treated wood is continuing. Although the rate of leaching from the wood has declined, it is probable that accumulated levels, especially those in soil, will remain elevated for many years because the elements are bound to the soil.

The construction of these boardwalk test sections in a sensitive environment and the levels of preservative components released did not appear to have any measurable negative effect on populations of aquatic invertebrates at the site. The biological impact of the treated wood used in this study is addressed in Part II of this report.

References

- Alloway, B.J.** 1990. Soil processes and the behaviour of metals. In: Alloway, B.J., ed. Heavy metals in soils. New York: John Wiley and Sons.
- Anon.** 1994. ACQ Type D. Proposal to the AWWPA technical committees to include ACQ Type D in Standards P5, C1, C2, C15, C9, and M6. Charlotte, NC: Chemical Specialties, Inc.
- Anon.** 1985. Trough leaching test for ACZA. Res. Rep. San Mateo, California: J.H. Baxter and Company.

- Arsenault, R.D.** 1975. CCA-treated wood foundations. A study of permanence, effectiveness, durability and environmental considerations. In: Proceedings, American Wood Preservers' Association. Woodstock, MD: American Wood Preservers' Association. 71: 126–146.
- Arsenault, R.D.; Freeman, M.H.; Stokes, D.K.** 1993. Proposal to American Wood Preservers' Association to include copper dimethyldithiocarbamate in AWPA Standard P5. Woodstock, MD: American Wood Preservers' Association.
- ASTM.** 1983. Standard practice for thin-walled tube sampling of soil. D1587–83. Philadelphia, PA: American Society of Testing and Materials. Vol. 04.08.
- ASTM.** 1989. Standard practice for preserving and transporting soil samples. D4220–89. Philadelphia, PA: American Society of Testing and Materials. Vol. 04.08
- ASTM.** 1991. Standard practices for handling, storing and preparing soft, undisturbed marine soil. D3213–91. Philadelphia, PA: American Society of Testing and Materials. Vol. 04.08.
- AWPA.** 1995. Book of Standards. Woodstock, MD: American Wood Preservers' Association.
- AWPA.** 1997. Book of Standards. Woodstock, MD: American Wood Preservers' Association.
- Baker, D.E.** 1990. Copper. In: Alloway, B.J., ed. Heavy metals in soils. New York: John Wiley and Sons.
- Bergholm, J.** 1990. Studies on the mobility of arsenic, copper, and chromium in CCA contaminated soils. IRG/WP/3571. Stockholm, Sweden: International Research Group.
- Bergholm, J.** 1992. Leakage of arsenic, copper and chromium from preserved wooden chips deposited in soil. An eleven year old field experiment. Rep. 166. Stockholm, Sweden: Swedish Wood Preservation Institute.
- Bergholm, J.; Dryler, K.** 1989. Studies on the fixation of arsenic in soil and on the mobility of arsenic, copper and chromium in CCA-contaminated soil. Rep. 161. Stockholm, Sweden: Swedish Wood Preservation Institute.
- Bergman, G.** 1983. Contamination of soil and ground water at wood preserving plants. Rep. 146. Stockholm, Sweden: Swedish Wood Preservation Institute.
- Best, C.W.; Coleman, C.D.** 1981. AWPA Standard M11: An example of its use. In: Proceedings, American Wood Preservers' Association. 77: 35–40.
- Bodek, I.; Lyman, W.J.; Reehl, W.F.; Rosenblatt, R.H.** 1988. Environmental inorganic chemistry. New York, Pergamon Press.
- Brown, H.S.** 1986. Natural amounts of As, Cr, and Cu in soils and water. In: Proceedings, American Wood Preservers' Association. 82: 79–94.
- Brown, K.W.; Breckinridge, R.P.; Rope, R.C.** 1993. U.S. Fish and Wildlife Service lands biomonitoring operations manual. Appendix J. Soil sampling and reference field methods. EGG-EST-9222.
- Chen, S.C.; Walters, C.S.** 1979. The fate of arsenic in pressure treated Southern Pine plywood exposed to artificial rainfall. In: Proceedings, American Wood Preservers' Association. 75: 188–233.
- Cockcroft, R.; Laidlaw, R.A.** 1978. Factors affecting leaching of preservatives in practice. IRG/WP/3113. Stockholm, Sweden: International Research Group.
- Comfort, M.** 1993. Environmental and occupational health aspects of using CCA treated timber for walking track construction in the Tasmanian Wilderness World Heritage Area. Scientific Rep. 93/1. Hobart, Tasmania: Tasmanian Parks and Wildlife Service.
- Cooper, P.A.** 1990. Leaching of CCA from treated wood. In: Proceedings, Canadian Wood Preservers' Association. 11: 144–169.
- Cooper, P.A.** 1991. Leaching of wood preservatives from treated wood in-service. Report prepared for Public Works Canada. 79 p.
- Cooper, P.A.; Stokes, D.** 1993. Leaching characteristics and fixation of copper dimethyldithiocarbamate treated wood. In: Proceedings, American Wood Preservers' Association. 89: 192–203.
- Cooper, P.A.; Ung, Y.T.** 1992a. Accelerated fixation of CCA treated poles. Forest Products Journal. 42(9): 27–32.
- Cooper, P.A.; Ung, Y.T.** 1992b. Leaching of CCA-C from jack pine sapwood in compost. Forest Products Journal. 42(9): 57–59.
- Cooper, P.A.; Ung, Y.T.** 1993. A simple leaching procedure for in-plant monitoring of CCA fixation. IRG/WP/30023. Stockholm, Sweden: International Research Group.
- De Groot, R.C.; Popham, T.W.; Gjovik, L.R.; Forehand, T.** 1979. Distribution gradients of arsenic, copper, and chromium around preservative treated wooden stakes. Journal of Environmental Quality. 8: 39–41.
- Dowdy, R.H.; Volk, V.V.** 1983. Movement of heavy metals in soils. In: Nelson, D.W. and others, eds. Chemical mobility and reactivity in soil systems. Madison, WI: Soil Science Society of America: 220–240.
- Eisler, R.** 1993. Zinc hazards to fish, wildlife, and invertebrates: A synoptic review. Biological Rep. 10. Contaminant Hazards Reviews Rep. 26. Washington, D.C.: U.S. Department of Interior, Fish and Wildlife Service.
- EPA.** 1982. Handbook for sampling and sample preservation of water and wastewater. EPA-600/4-82-029. Washington, DC: Environmental Protection Agency.

- EPA.** 1995. Test methods for evaluating solid waste. SW846, Updated III. 3rd ed. Washington, D.C.: Environmental Protection Agency.
- Evans, F.G.** 1987. Leaching from CCA-impregnated wood to food, drinking water and silage. IRG/WP/3433. Stockholm, Sweden: International Research Group.
- Fahlstrom, G.B., Gunning, P.E.; Carlson, J.A.** 1967. Copper-chrome-arsenate wood preservatives: a study of the influence of composition on leachability. *Forest Products Journal*. 17(7): 17-22.
- Ferguson, J.F.; Gavis, J.** 1972. A review of the arsenic cycle in natural waters. *Water Resources*. 6: 1259-1274.
- Florence, T.M.; Batley, G.E.** 1980. Chemical speciation in natural waters. *CRC Critical Reviews in Analytical Chemistry*. 9: 219-296.
- Fordham, A.W.; Norrish, K.** 1974. Direct measurement of the contamination of soil components which retain added arsenate. *Australian Journal Soil Research*. 12: 165-172.
- Foster, D.O.** 1989. Determination of the presence of hexavalent chromium in treated wood. In: *Proceedings, American Wood Preservers' Association*. 85: 136.
- Fowle, D.A.; Preston, A.F.; Zahora, A.R.** 1990. Additives: an example of their influence on the performance and properties of CCA-treated southern pine lumber. In: *Proceedings, American Wood Preservers' Association*. 86: 11-21.
- Freeman, M.H.; Stokes, D.K.; Woods, T.L.; Arsenault, R.D.** 1994. An update on the wood preservative copper dimethyldithiocarbamate. In: *Proceedings, American Wood Preservers' Association*.
- Frost, R.R.; Griffin, R.A.** 1977. Effects of pH on adsorption of arsenic and selenium from landfill leachate by clay minerals. *Soil Science Society of America*. 41: 53-57
- Gieseking, J.E.** 1975. Soil components. Vol 1. Organic components. New York: Springer-Verlag.
- Gilbert, R.D.** 1987. Statistical methods for environmental pollution monitoring. New York: Van Nostrand Reinhold. 320 p.
- Gjovik, L.R.; Bendtsen, B.A.; Roth, H.G.** 1972. Condition of preservative-treated cooling tower slats after 10 years of service. *Forest Products Journal*. 22(4): 35-40.
- Gutzmer, D.I.; Crawford, D.M.** (comps). 1995. Comparison of wood preservatives in stake tests—1995 progress report. Res. Note FPL-RN-02. Madison, WI: U.S. Department of Agriculture, Forest Service, Forest Products Laboratory. 124 p.
- Holland, G.E.; Orsler, R.J.** 1995. Methods for assessment of wood preservative movement in soil. In: *The challenge: safety and the environment. Proceedings, 3rd international wood preservation symposium; Cannes-Mandelieu, France.* IRG/WP 95-50040. Stockholm, Sweden: International Research Group. 118-145.
- Irvine, J; Eaton, R.A.; Jones, E.B.G.** 1972. The effect of water of different composition on the leaching of a water-borne preservative from timber placed in cooling towers and in the sea. *Material und Organismen*. 7: 45-71.
- Jin, L.; Archer, K.; Preston, A.F.** 1992. Depletion and biodeterioration studies with developmental wood preservative formulations. In: *Proceedings, American Wood Preservers' Association*. 108-125.
- Kim, J.J.; Kim, G.H.** 1993. Leaching of CCA components from treated wood under acidic conditions. IRG/WP/93-50004. Stockholm, Sweden, International Research Group.
- Lebow, S.T.** 1992. Interactions of ammoniacal copper zinc arsenate (ACZA) wood preservatives with Douglas-fir. Corvallis, OR: Oregon State University. Ph.D. thesis.
- Lebow, S.T.** 1996. Leaching of wood preservative components and their mobility in the environment- Summary of pertinent literature. Gen. Tech. Rep. FPL-GTR-93. Madison, WI: U.S. Department of Agriculture, Forest Service, Forest Products Laboratory. 36 p.
- Lebow, S.T.; Evans, J.W.** 1999. Effect of a pre-stain on the release rate of copper, chromium, and arsenic from western hemlock. Res. Note FPL-RN-0271. Madison, WI: U.S. Department of Agriculture, Forest Service, Forest Products Laboratory. 6 p.
- Lorentzen, M.L.; Kingston, H.M.** 1996. Comparison of microwave assisted and conventional leaching using EPA Method 3050B. *Analytical Chemistry*. 68: 4316-4320.
- Lund, U.; Fobian A.** 1991. Pollution of two soils by arsenic, chromium, and copper. *Denmark: Geoderma*. 49: 83-103.
- McGrath, S.P.; Smith, S.** 1990. Chromium and nickel. In: Alloway, B.J., ed. *Heavy metals in soils*. New York: John Wiley and Sons: 125-150.
- McNamara, W.S.** 1989. CCA fixation experiments. Part I. IRG/WP/3504. Stockholm, Sweden: International Research Group.
- Meade, R.H.** 1995. Contaminants in the Mississippi River, 1987-92. Circular 1133. Reston, VA: U.S. Geologic Survey.
- Merkle, P.; Gallagher, D.L.; Solberg, T.N.** 1993. Leaching rates, metals distribution and chemistry of CCA-treated lumber: implications for water quality modeling. In: *Proceedings, symposium on environmental considerations in the use of pressure treated wood*. Richmond, VA: Forest Products Society.
- Messure, K.; Martin, R.E.; Fish, W.** 1991. Identification of copper contamination in sediments by a microscale partial extraction technique. *Journal of Environmental Quality*. 20: 114-118.
- Morgan, J.** 1989. The evaluation and commercialization of a new wood preservative. In: *Proceedings, American Wood Preservers' Association*, 85: 16-26.

- Mudroch, A.; MacKnight, S.D.** eds. 1991. CRC handbook of techniques for aquatic sediments sampling. Boston, MA: CRC Press.
- Murphy, R.J.; Dickinson, D.J.** 1990. The effect of acid rain on CCA treated timber. IRG/WP/3579. Stockholm, Sweden: International Research Group.
- NADP.** 1998. National atmospheric deposition program (NRSP-3)/national trends network. Champaign, IL: National Atmospheric Deposition Program Office.
- Newell, A.V.; Sanders, J.G.** 1986. Relative copper binding capacities of dissolved organic compounds in a coastal plain estuary. *Environmental Science and Technology*. 20: 817–820.
- O'Neill, P.** 1990. Arsenic. In: Alloway, B.J., ed. *Heavy metals in soils*. New York: John Wiley and Sons: 83–99.
- Ott, W.R.** 1995. *Environmental Statistics and Data Analysis*. Boca Raton, FL: Lewis Publishers. 313 p.
- Plackett, D.V.** 1984. Leaching tests on CCA treated wood using inorganic salt solutions. IRG/WP/3310. Stockholm, Sweden: International Research Group.
- Rak, J.** 1976. Leaching of toxic elements from spruce treated with ammoniacal solutions of copper zinc arsenate preservatives. *Wood Science Technology*. 10: 47–56.
- Ruddick, J.N.R.** 1993. Bacterial depletion of copper from CCA-treated wood. *Material und Organismen*. 27(2): 135–144.
- Shelver, G.D.; McQuaid, C.D.; Baecker, A.A.W.** 1991. Leaching of CCA from *Pinus patula* during marine trials in the southern hemisphere. IRG/WP/4167. Stockholm, Sweden: International Research Group.
- Sheppard, M.I.; Thibault D.H.** 1991. A four-year mobility study of selected trace elements and heavy metals. *Journal of Environmental Quality*. 20: 101–114.
- Spotte, S.** 1979. *Fish and invertebrate culture*. New York: John Wiley and Sons.
- Stackhouse, R.A.; Benson, W.H.** 1989. The effect of humic acid on the toxicity and bioavailability of trivalent chromium. *Ecotoxicology Environmental Safety* 17(1): 105–111.
- Stevenson, F.J.; Fitch, A.** 1981. In: Lonegran, J.F. and others, eds. *Copper in soil and plants*. New York: Academic Press. 69–95.
- Stilwell, D.E.; Gorny, K.D.** 1997. Contamination of soil with copper, chromium and arsenic under decks built from pressure treated wood. *Bulletin of Environmental Contamination, and Toxicology*. 58: 22–29.
- Tan, K.H.** 1993. *Principles of soil chemistry*. 2nd ed. New York: Marcel Dekker, Inc.
- Teichman, T.; Monkan, J.L.** 1966. An investigation of inorganic wood preservatives: Part I. The stability to extraction of arsenic impregnated wood. *Holzforschung*. 20(4): 125–127.
- Tippie, M.** 1993. Integrating the selection of construction materials for boardwalks with the needs of sensitive habitats and key species on the Mt. Hood National Forest. Paper prepared in partial fulfillment of requirements for Professional Development for Outdoor Recreation Management Program. Clemson, SC: Clemson University.
- USDA.** 1980. The biologic and economic assessment of pentachlorophenol, inorganic arsenicals and creosote. Vol 1. Wood preservatives. Tech. Bull. 1658-1. Washington, DC: U.S. Department of Agriculture.
- Van Eetvelde, G.; Homan, J.W.; Militz, H.; Stevens, M.** 1995. Effect of leaching temperature and water acidity on the loss of metal elements from CCA treated timber in aquatic conditions. Part 2. Semi-industrial investigation. In: *Proceedings, 3rd International Wood Preservation Symposium, The Challenge—Safety and the Environment*. Cannes–Mandelieu, France. IRG/WP 95-50040: 195–208.
- Walsh, L.M.; Keeney, D.R.** 1975. Behaviour and phytotoxicity of inorganic arsenicals in soils. In: Woolson, E.A., ed. *Arsenical pesticides ACS symposium Ser. 7*. American Chemical Society annual meeting; Atlantic City, NJ. Washington, DC: American Chemical Society: 35–52.
- Warner, J.E.; Solomon, K.R.** 1990. Acidity as a factor in leaching of copper, chromium and arsenic from CCA-treated dimension lumber. *Environmental Toxicology and Chemistry*. 9: 1331–1337.
- Western Wood Preservers' Institute.** 1996. *Best management practices for the use of treated wood in aquatic environments*. Vancouver, WA: Western Wood Preservers' Institute. 35 p.
- Wilson, A.** 1971. The effects of temperature, solution strength, and timber species on the rate of fixation of a copper-chrome-arsenate wood preservative. *Journal of Institute of Wood Science*. 5(6): 36–40.
- Woolson, E.A.; Gjovik, L.R.** 1981. The valence state of arsenic on treated wood. In: *Proceedings of the American Wood Preservers' Association*. 77: 1–5.
- Wright, J.K.** 1989. The valence state of chromium in treated wood, studied by magnetic susceptibility. *Journal of Wood Chemistry Wood Chemistry and Technology*. 9(4): 569–572.
- WWPI.** 1996. *Best management practices for the use of treated wood in aquatic environments*. Vancouver, WA: Western Wood Preservers' Institute: 1–35.

Appendix IA—Framing Details for Typical Boardwalk Sections and Viewing Platforms

Metric conversions for figures:

1 ft = 0.3048 m; 1 in. = 25.4 mm

Nominal 2 × 4 in. = standard 38 × 89 mm

2 × 6 in. = 38 × 140 mm

2 × 8 in. = 38 × 184 mm

2 × 12 in. = 38 × 286 mm

4 × 12 in. = 89 × 286 mm

6 × 6 in. = 140 × 140 mm

6 × 10 in. = 140 × 235 mm

6 × 12 in. = 140 × 286 mm

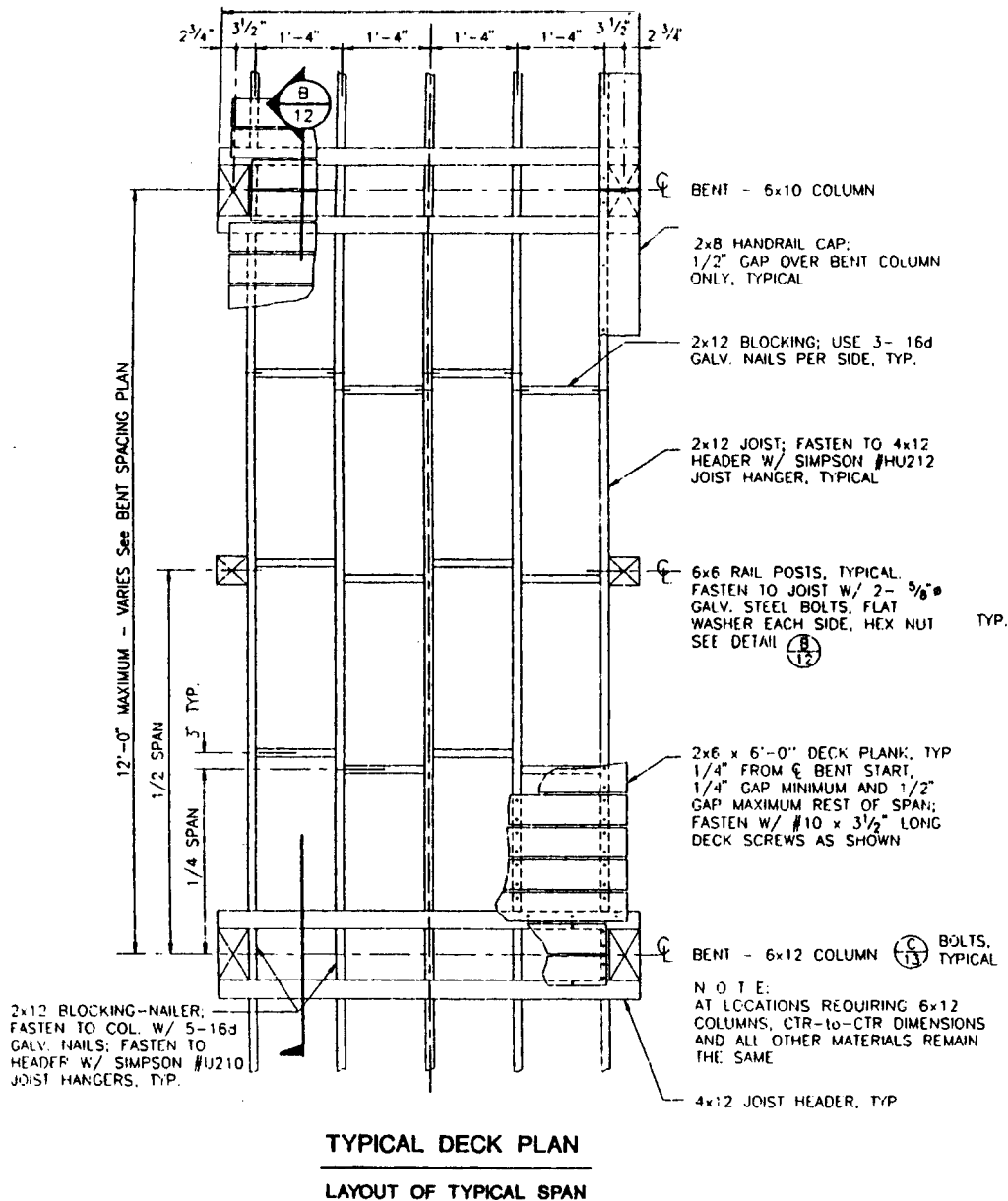

Figure I-8—Framing plan for boardwalk, top view.

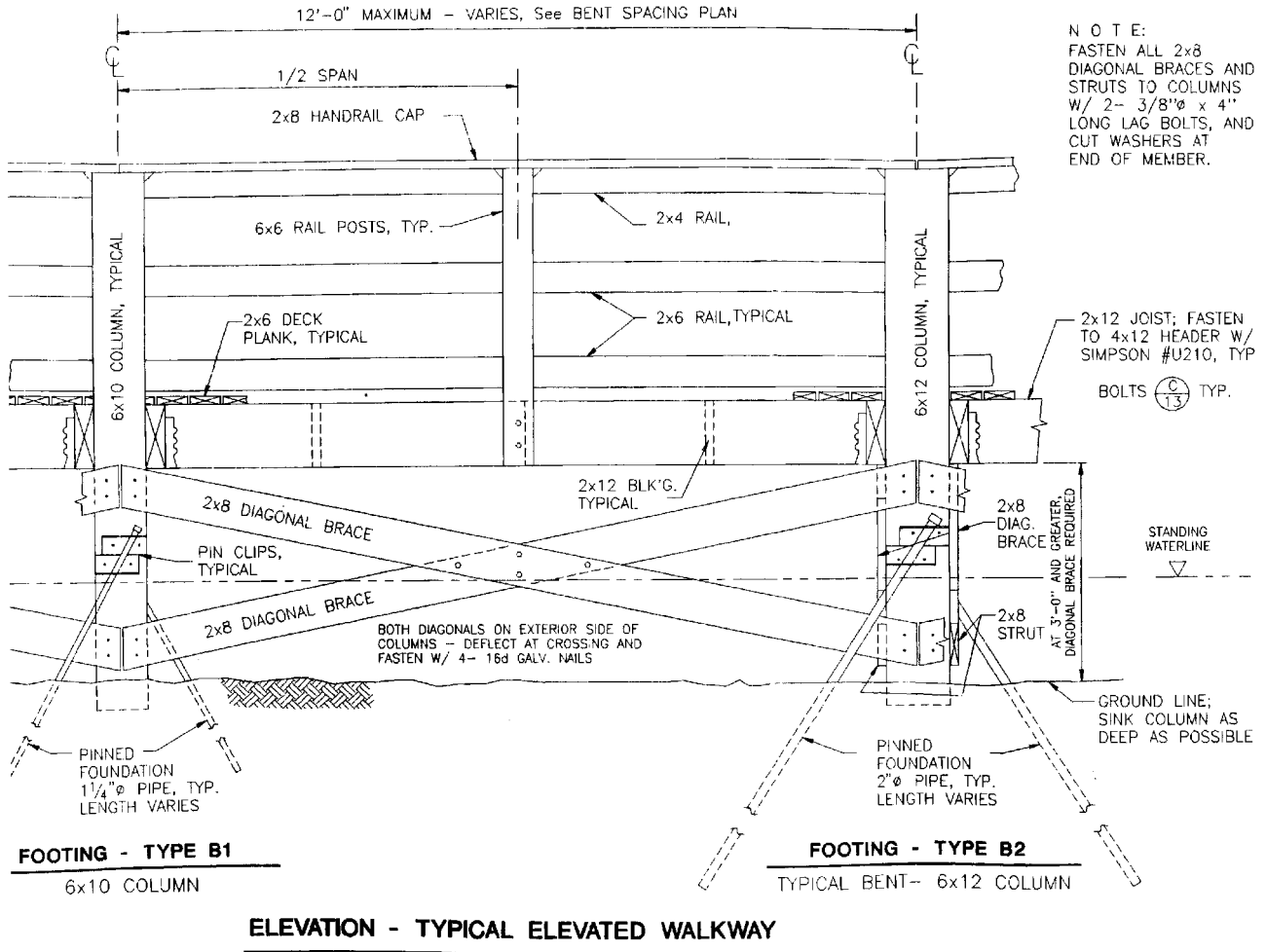
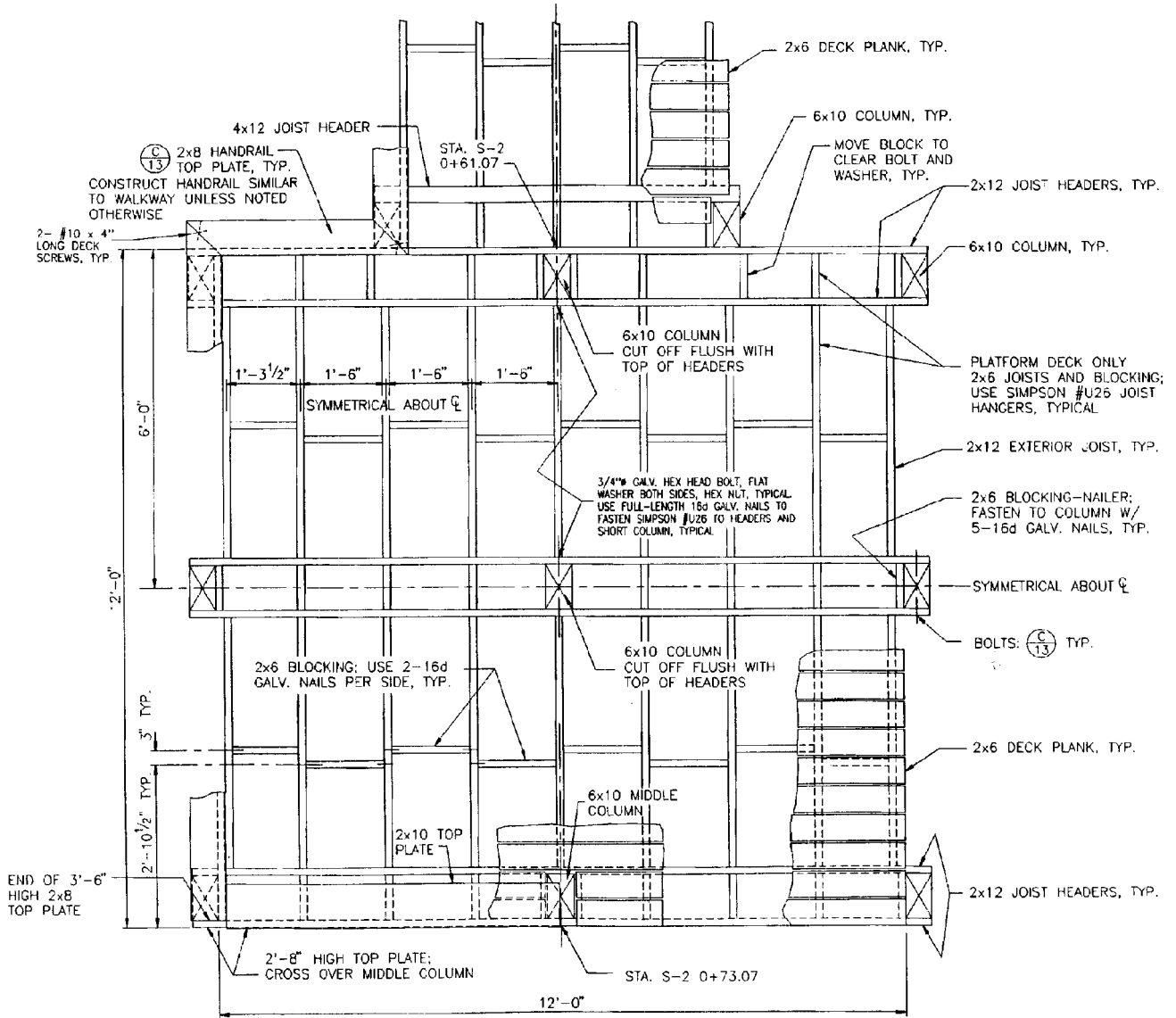

Figure I-9—Framing plan for boardwalk, side view. Pinned piling and cross bracing were used in sediment areas.



(A) ————— FRAMING PLAN

Figure I-10—Framing details for construction of ACQ-B viewing platform, top view.

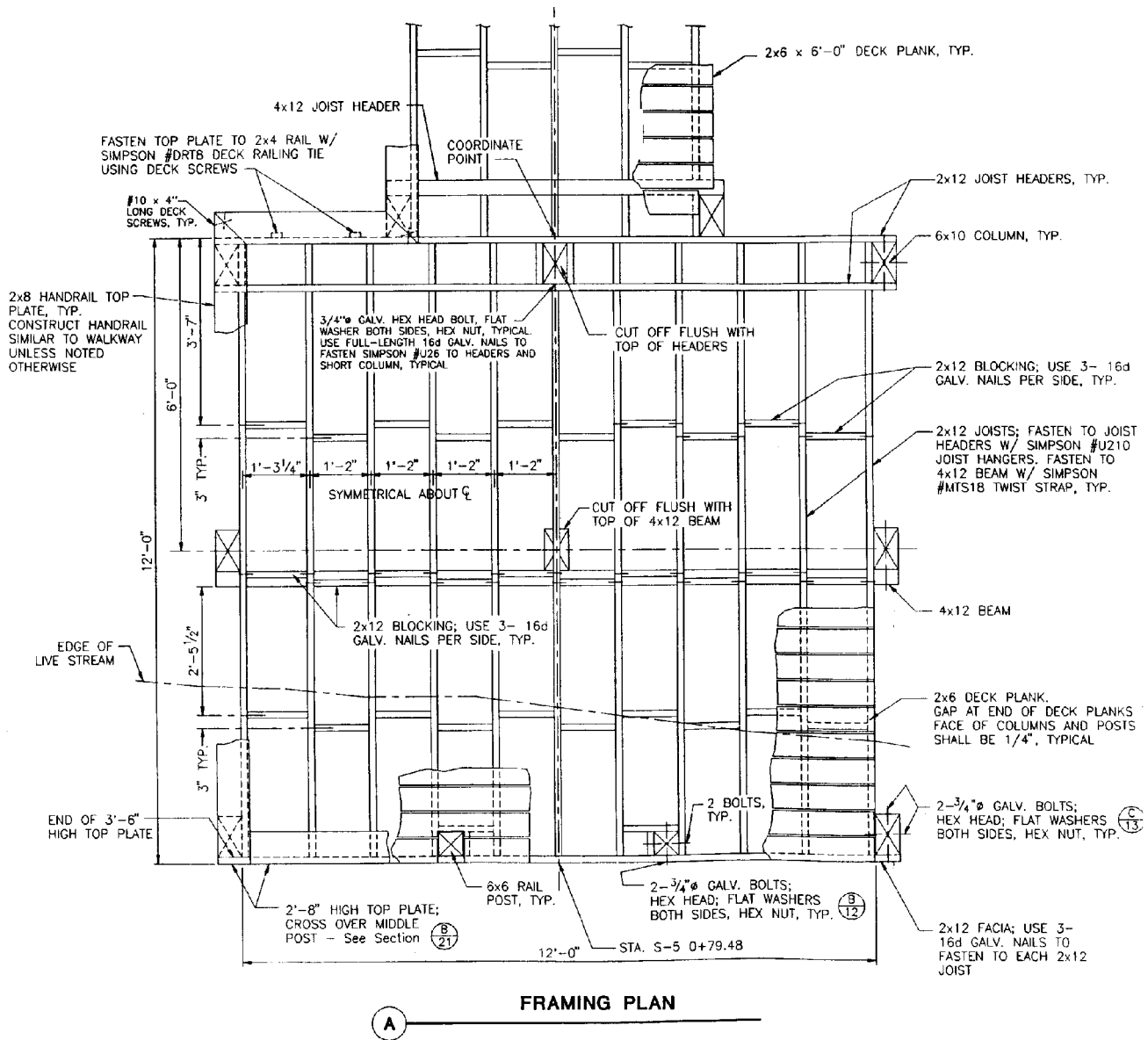

Figure I-11—Framing details for construction of CDDC viewing platform, top view.

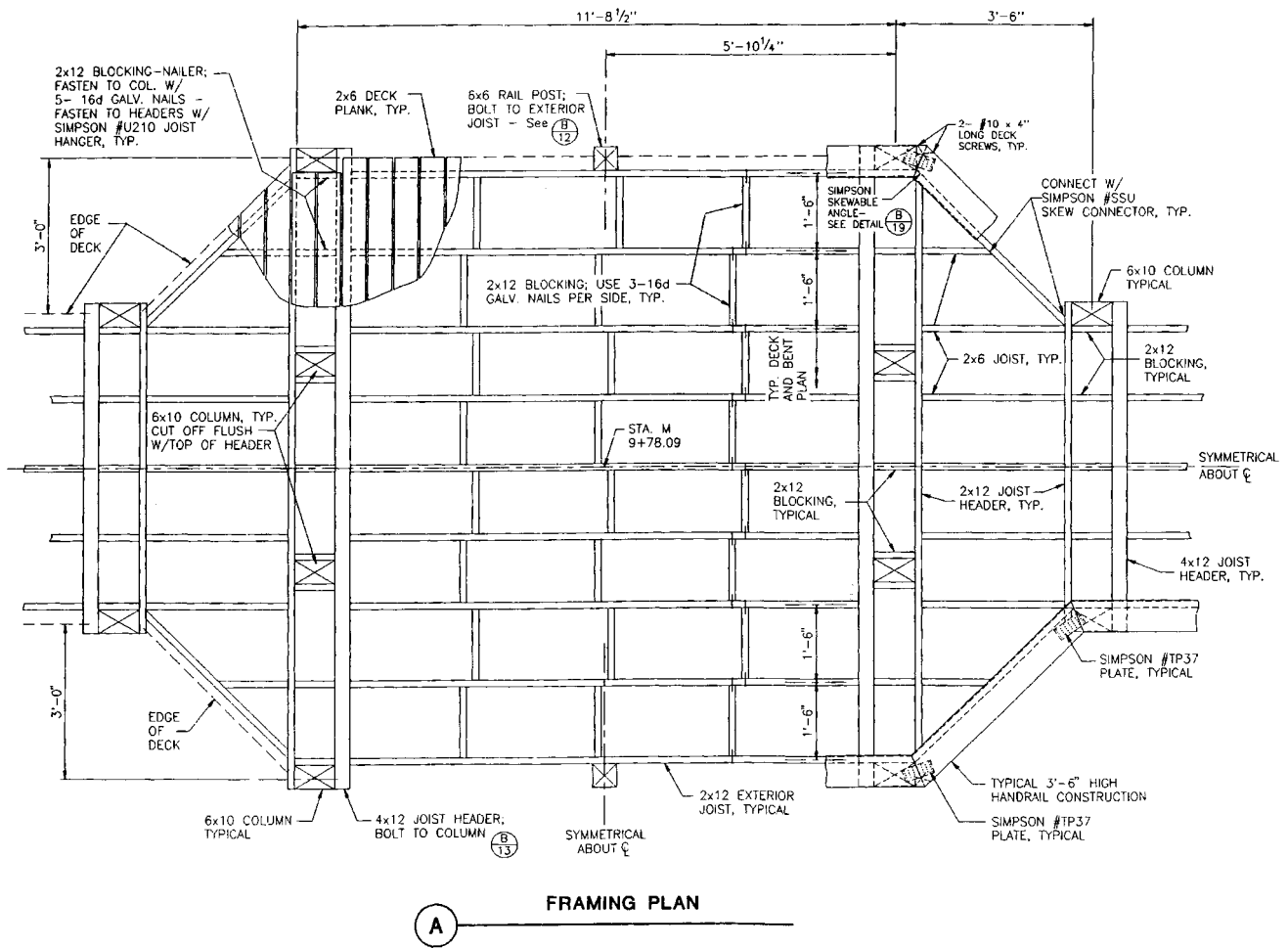

Figure I-12—Framing details for construction of CCA-C viewing platform, top view.

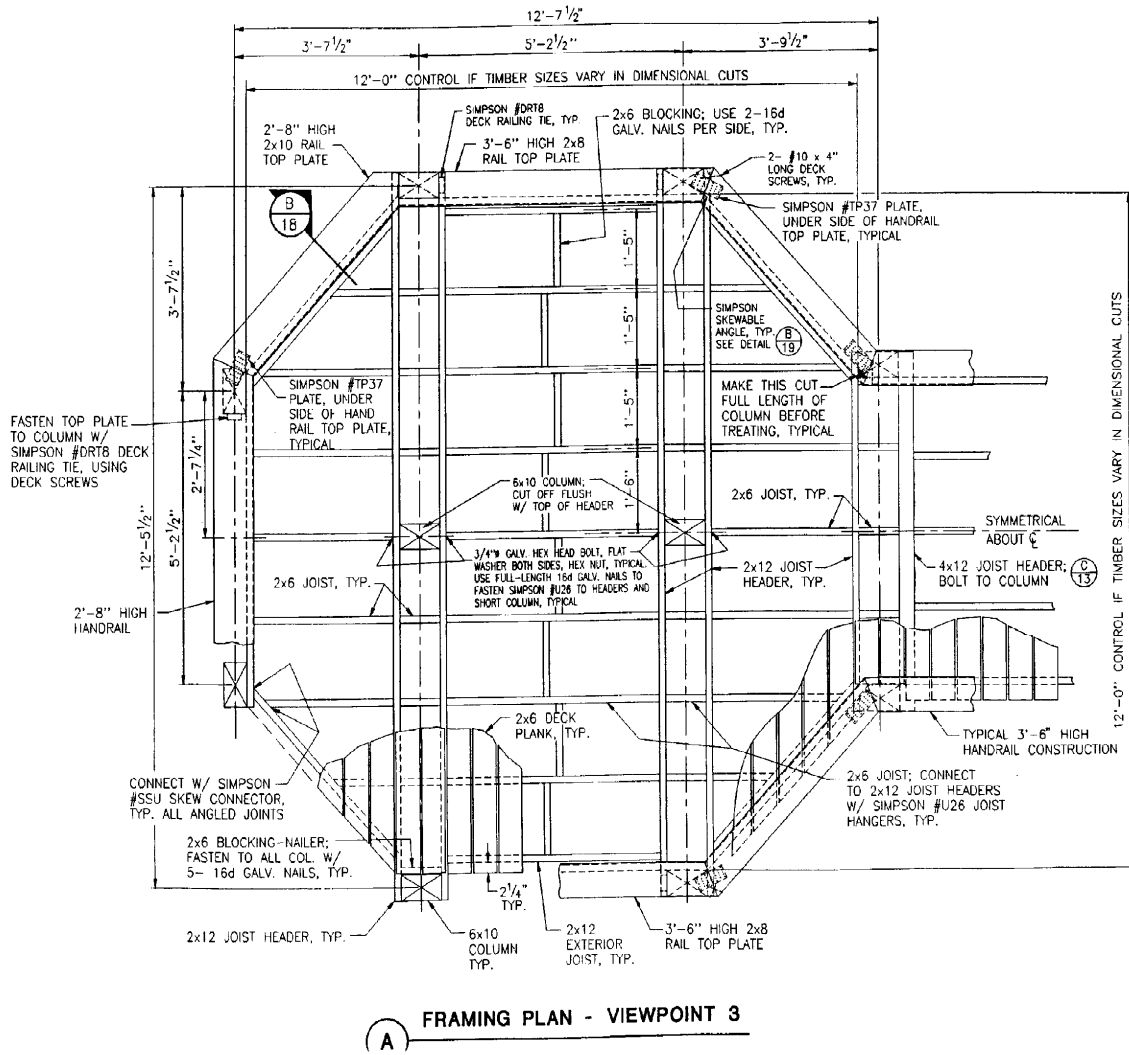

Figure I-13—Framing details for construction of ACZA viewing platform, top view.

Appendix IB—Overview of Test Sections and Sampling Transects

Metric conversions for figures:
 1 ft = 0.3048 m; 1 in. = 25.4 mm

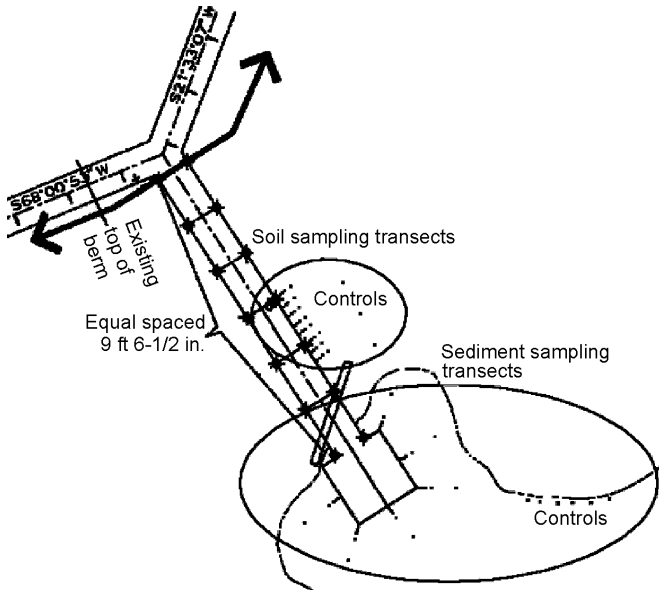

Figure I-14—Overview of ACQ-B test section, including area of sampling transects.

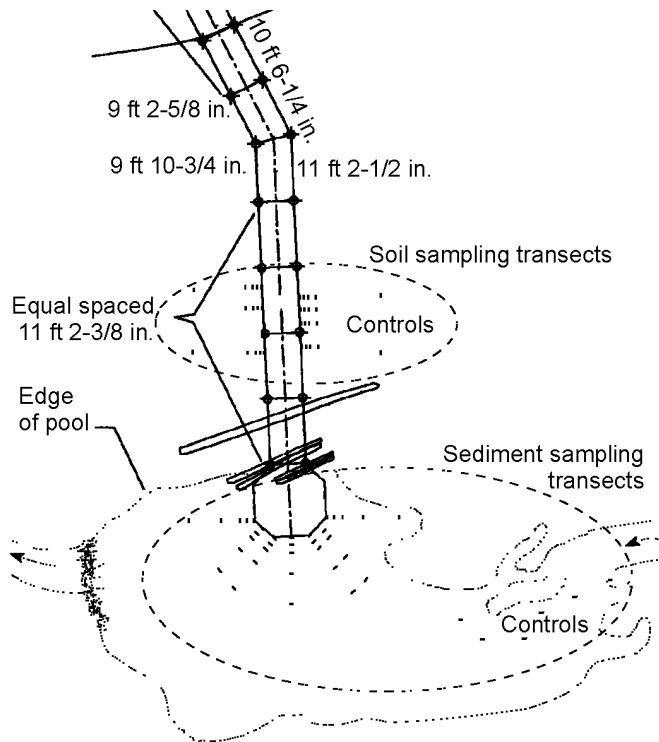

Figure I-15—Overview of ACZA test section, including area of sampling transects.

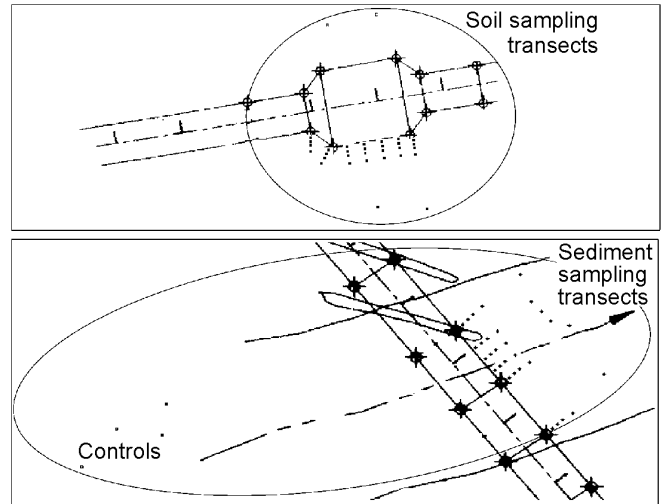

Figure I-16—Overview of CCA-C test section, including area of sampling transects.

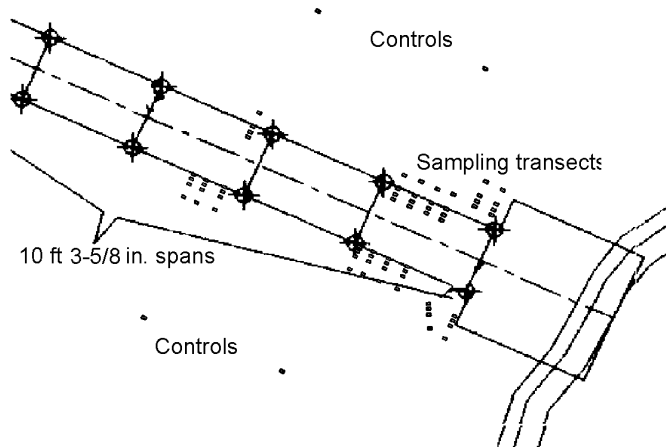

Figure I-17—Overview of CDDC test section, including area of sampling transects.

Appendix IC—Preservative Concentrations

The figures in this appendix show the location of sampling transects in relation to boardwalks treated with CCA–C, ACZA, ACQ–B, and CDDC. The tables show concentrations of preservative components in individual soil and sediment samples.

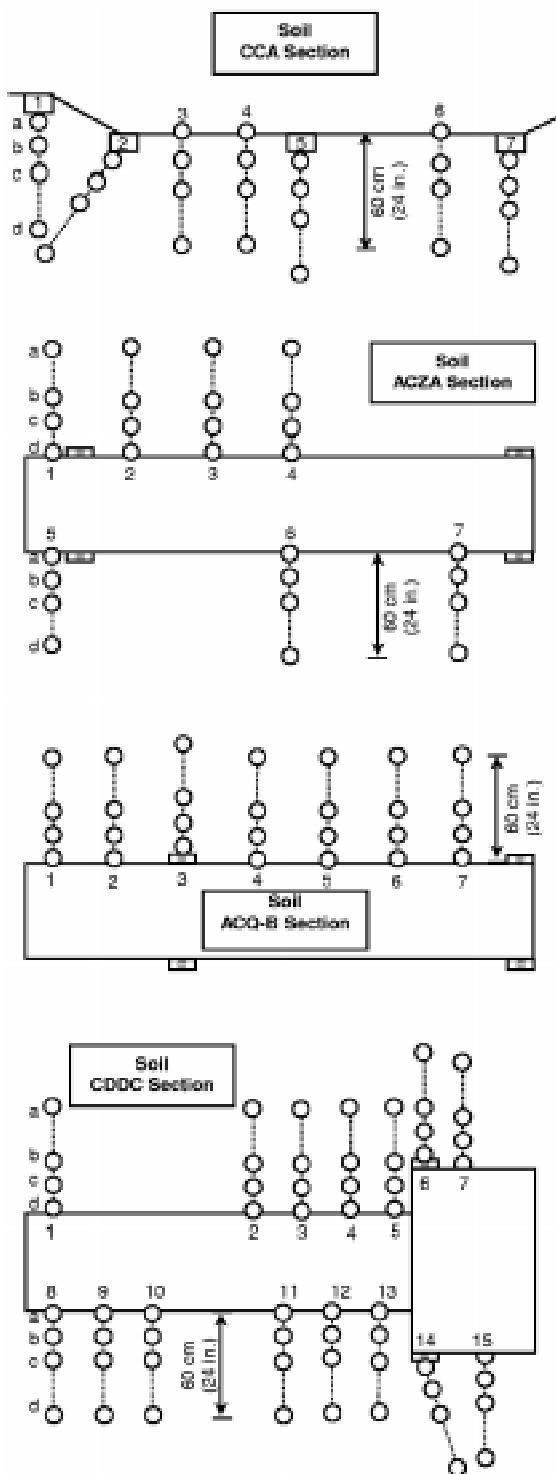

Figure I-18. Soil sampling transects (1–7) and distances from boardwalk (a–d) for various test sections. a = 0 cm from edge of boardwalk, b = 15 cm, c = 30 cm, and d = 60 cm (0, 6, 12, and 24 in., respectively).

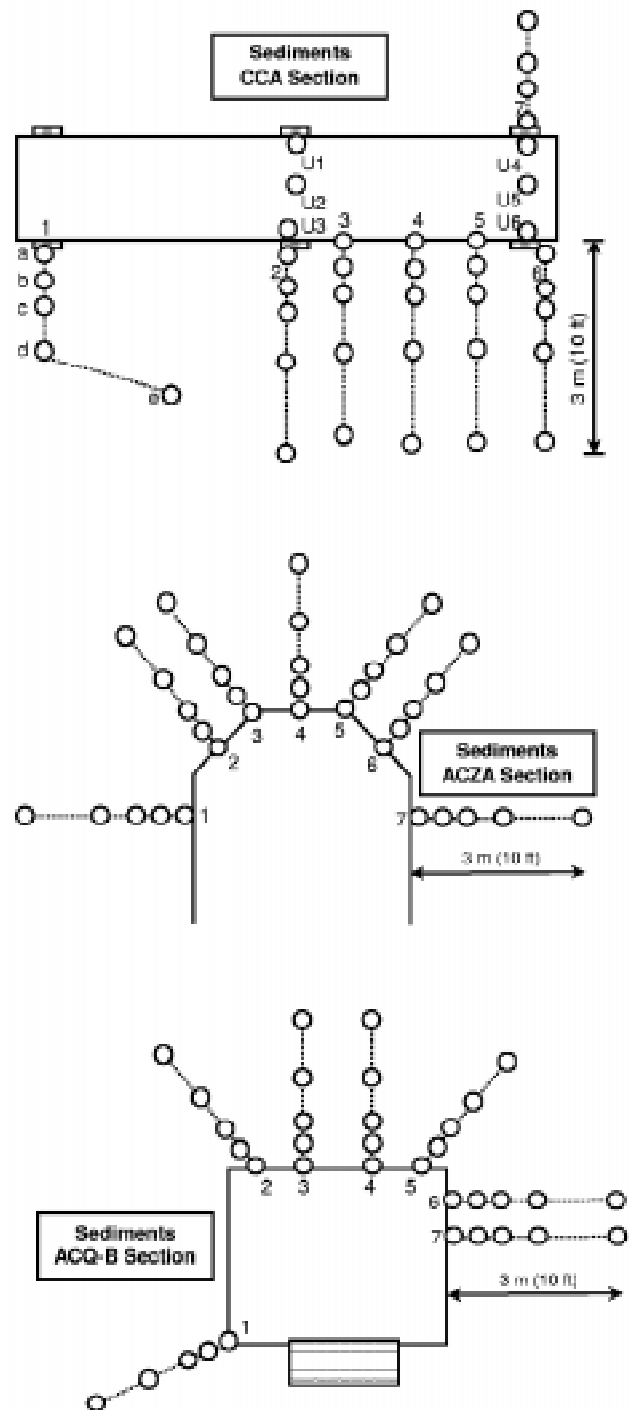

Figure I-19. Sediment sampling sites, sampling transects, and distances from boardwalk for various test sections. For the CCA section, U1 to U6 designate sites where samples were taken from directly beneath the boardwalk. For all sections, a = 0 cm from edge of boardwalk, b = 30 cm, c = 60 cm, d = 150 cm, and e = 300 cm (0, 12, 24, 59, and 118 in., respectively).

Table I-24—CCA section: copper, chromium, and arsenic in soil samples

Element	Soil depth (cm (in.))	Time (mo)	Concentration in soil samples (ppm) at various transects (1-7) and distances from boardwalk (a-d) ^a																																	
			1				2				3				4				5				6				7				Control ^b					
			a	b	c	d	a	b	c	d	a	b	c	d	a	b	c	d	a	b	c	d	a	b	c	d	a	b	c	d						
Cu	0-15 (0-6)	0.5	21	23	23	23	21	25	27	24	23	24	24	22	21	22	22	21	23	21	20	20	23	17	19	20	23	20	22	19	23	24	18	22	23, 24, 18, 22	
		2	25	24	26	24	24	24	27	24	27	24	22	22	29	22	20	22	32	23	21	25	25	19	20	21	24	21	22	22	24	23	22	22	24, 23, 22, 21	
		5.5	26	22	22	21	24	25	22	21	24	24	21	23	29	19	22	19	20	17	20	19	34	21	18	18	27	20	19	21	23	20	17	19	23, 20, 17, 19	
		11	21	27	29	21	51	30	27	22	24	21	22	22	28	23	24	21	25	22	19	24	29	19	18	19	56	38	23	21	24	22	19	18	24, 22, 19, 18	
	15-30 (6-12)	0.5	20	25	21	23	21	24	24	23	18	25	24	23	21	23	21	25	21	23	24	21	28	20	22	22	27	23	20	24	-	23	-	-	-	
		2	24	26	-	23	23	27	22	23	22	25	24	21	24	23	24	24	22	24	23	23	17	23	21	20	25	20	-	23	-	22	24	-	-	
		5.5	29	23	24	22	26	24	23	26	25	23	19	23	21	23	21	22	24	22	25	25	22	21	20	22	26	21	21	26	21	21	26	21	21, -, -, 21	
		11	27	28	-	-	37	29	24	23	24	23	23	21	26	22	24	22	26	24	23	22	20	21	23	22	26	24	20	24	21	-, 23	-	-	21, -, 23, -	
	Cr	0-15 (0-6)	0.5	7	8	8	8	7	9	9	8	7	8	8	8	7	8	7	8	8	9	8	7	7	7	7	7	8	7	7	6	8	9	6	7	8, 9, 6, 7
			2	9	8	10	9	9	8	9	9	8	8	8	8	9	7	8	8	9	8	9	10	8	7	8	8	9	8	8	8	9	8	8	8	9, 8, 9, 6
			5.5	8	7	11	9	8	7	10	8	11	10	13	9	9	9	9	7	7	7	9	7	8	8	7	10	9	9	11	8	7	8	8	9	7, 8, 8, 9
			11	9	8	17	11	13	8	11	10	8	7	10	9	8	10	18	10	9	10	9	12	11	6	9	7	10	12	20	9	10	8	7	10	9, 10, 8, 7, 10
15-30 (6-12)		0.5	10	12	11	9	8	9	14	13	7	16	12	11	6	3	10	11	6	10	12	10	6	9	14	11	7	9	9	11	-	11	-	-	-	
		2	11	13	-	8	12	12	13	12	10	12	12	12	13	9	10	11	11	12	12	10	10	11	12	10	13	9	-	12	-	11	8	-	-	
		5.5	10	8	8	8	9	9	7	9	8	9	8	6	7	8	6	7	7	7	7	8	6	6	5	7	7	6	4	9	8	-, -, 9	9	8	8, -, -, 9	
		11	9	10	-	-	11	10	12	10	7	9	10	9	9	8	13	9	10	10	11	7	7	8	11	8	7	8	9	9	10	-, 9	-	-	10, -, 9, -	
As	0-15 (0-6)	0.5	4	1	2	1	3	2	2	1	5	1	2	1	4	2	1	1	6	1	1	1	5	1	1	1	5	1	1	1	1	1	1	1	1, 1, 1, 2	
		2	1	2	2	2	2	4	3	2	3	2	2	2	3	2	1	1	4	5	4	1	6	1	3	1	1	2	1	1	2	1	1	1	2, 1, 1, 3	
		5.5	6	4	3	1	4	2	3	3	2	2	1	2	4	1	3	2	9	1	1	1	36	7	3	1	11	1	1	1	1	1	1	1	1, 1, 1, 2	
		11	5	7	6	3	29	14	7	4	7	3	5	4	15	5	0	2	7	9	2	5	16	4	3	4	24	11	0	3	1	1	3	2	1, 1, 3, 2	
	15-30 (6-12)	0.5	3	3	3	3	3	4	3	2	2	6	3	7	3	3	3	3	2	4	3	2	2	3	3	3	2	4	3	1	-	4	-	-	-	
		2	4	5	-	3	4	4	5	4	6	4	4	3	6	4	3	3	3	6	4	4	3	6	4	3	5	3	-	4	-	3	3	-	-	
		5.5	4	3	3	2	3	3	2	2	3	3	2	3	2	2	2	2	3	2	2	3	2	2	2	3	-	2	2	2	4	-, -, 2	2	4	4, -, -, 2	
		11	5	4	-	-	16	3	6	3	3	3	5	3	2	2	6	3	2	3	4	2	2	2	5	4	10	4	4	4	4	3	-, -, 3	3	3, -, -, 3	

^aValues underlined and in bold type are elevated above those of preconstruction samples based on 95% tolerance level. See Tables I-7, I-8, and I-9 in text for preconstruction values. Distances from boardwalk: a = 0 cm, b = 15 cm (6 in.), c = 30 cm (12 in.), d = 60 cm (24 in.).

^bControl samples removed from random locations at minimum of 3 m (10 ft) from boardwalk.

Table I-25—CCA section: copper, chromium, and arsenic in sediment samples away from boardwalk

Element	Sedi- ment depth (cm (in.))	Time (mo)	Concentration in sediment samples (ppm) at various transects (1-7) and distances from boardwalk (a-e) ^a																																	
			1					2					3					4					5					6					7			
			a	b	c	d	e	a	b	c	d	e	a	b	c	d	e	a	b	c	d	e	a	b	c	d	e	a	b	c	d	e	a	b	c	d
Cu	0-2.5 (0-1)	0.5	<u>48</u>	20	<u>48</u>	20	27	<u>43</u>	<u>40</u>	34	29	28	18	21	20	27	25	27	23	25	33	<u>37</u>	31	14	<u>42</u>	25	31	26	20	32	17	28				
		2	<u>36</u>	33	28	32	<u>37</u>	24	<u>48</u>	27	35	<u>38</u>	<u>37</u>	24	17	22	<u>49</u>	24	24	23	<u>45</u>	<u>54</u>	<u>39</u>	24	<u>55</u>	<u>47</u>	29	25	16	16	20	27				
		5.5	<u>46</u>	<u>64</u>	21	23	<u>89</u>	<u>62</u>	<u>59</u>	24	22	21	<u>37</u>	22	22	27	<u>138</u>	20	30	28	<u>113</u>	33	27	21	28	<u>39</u>	32	22	24	25	17	<u>40</u>				
	2.5-10 (1-4)	11	<u>92</u>	<u>56</u>	<u>49</u>	27	23	<u>39</u>	<u>83</u>	<u>53</u>	19	<u>38</u>	<u>51</u>	<u>48</u>	26	<u>47</u>	26	<u>43</u>	<u>71</u>	<u>61</u>	<u>51</u>	<u>38</u>	<u>95</u>	32	35	33	30	82	<u>66</u>	52	31	28	19	22	<u>36</u>	<u>39</u>
		0.5	22	20	24	21	22	20	24	16	14	17	18	17	17	17	33	23	24	21	25	<u>35</u>	25	22	<u>55</u>	30	33	24	20	18	19	23				
		2	32	<u>35</u>	21	20	23	22	22	17	23	20	26	22	17	20	<u>49</u>	31	23	19	<u>36</u>	<u>53</u>	24	17	<u>79</u>	23	21	22	20	17	21	19				
		5.5	22	17	17	13	20	<u>36</u>	26	14	19	22	—	15	20	24	29	18	19	16	22	23	20	22	21	20	20	23	18	19	18	19				
		11	<u>45</u>	21	25	15	21	27	27	<u>34</u>	14	26	30	<u>35</u>	20	17	22	20	<u>83</u>	25	22	21	32	22	21	20	21	22	23	29	21	21	16	17	22	<u>38</u>
		Cr	0-2.5 (0-1)	0.5	<u>35</u>	10	<u>27</u>	8	9	<u>19</u>	<u>22</u>	<u>17</u>	12	<u>15</u>	8	9	10	12	14	13	10	10	14	<u>21</u>	<u>15</u>	08	<u>37</u>	11	<u>17</u>	13	14	<u>20</u>	8	14		
	2			<u>20</u>	<u>16</u>	12	<u>15</u>	<u>17</u>	10	<u>22</u>	14	14	<u>18</u>	<u>17</u>	11	7	12	<u>21</u>	9	10	12	21	<u>38</u>	<u>29</u>	<u>17</u>	<u>33</u>	<u>26</u>	14	13	8	9	11	11			
	5.5			<u>18</u>	<u>30</u>	7	8	<u>17</u>	<u>18</u>	<u>23</u>	10	10	9	13	10	11	<u>15</u>	<u>38</u>	9	<u>16</u>	13	<u>38</u>	<u>19</u>	12	10	11	<u>16</u>	<u>17</u>	11	13	11	9	12			
	2.5-10 (1-4)		11	10	<u>28</u>	14	10	12	11	<u>40</u>	5	7	13	14	7	14	13	12	13	19	<u>19</u>	12	<u>18</u>	<u>32</u>	11	<u>16</u>	14	<u>18</u>	<u>31</u>	<u>22</u>	<u>24</u>	12	12	11	10	9
0.5			9	8	8	7	7	7	9	6	5	7	10	7	6	7	<u>16</u>	9	10	8	10	17	10	8	<u>35</u>	<u>16</u>	<u>16</u>	10	8	8	7	9				
2			15	13	6	7	7	9	7	5	7	6	8	12	5	7	<u>16</u>	13	11	6	14	<u>36</u>	10	8	<u>41</u>	8	7	8	7	7	8	9				
	5.5		9	6	7	4	7	10	8	5	7	9	—	6	10	10	10	7	8	6	9	11	8	11	8	7	8	9	8	7	7	9				
	11		<u>18</u>	7	8	2	7	6	6	8	3	8	7	8	6	6	6	6	19	10	9	6	8	7	4	8	7	8	6	8	9	10	7	5	10	9
	As		0-2.5 (0-1)	0.5	<u>32</u>	3	24	2	4	<u>18</u>	<u>16</u>	<u>10</u>	<u>12</u>	8	2	4	5	<u>11</u>	<u>10</u>	6	7	<u>9</u>	6	<u>13</u>	<u>8</u>	4	<u>30</u>	4	<u>15</u>	8	4	8	2	7		
2				<u>11</u>	<u>9</u>	6	7	<u>17</u>	3	<u>21</u>	<u>10</u>	<u>12</u>	<u>16</u>	<u>15</u>	5	3	<u>22</u>	<u>26</u>	<u>20</u>	6	6	<u>16</u>	<u>28</u>	<u>24</u>	<u>13</u>	<u>34</u>	<u>24</u>	<u>10</u>	8	2	3	3	6			
5.5				<u>18</u>	<u>35</u>	2	5	<u>31</u>	<u>21</u>	<u>39</u>	5	4	3	<u>8</u>	4	5	<u>15</u>	<u>88</u>	5	<u>11</u>	<u>9</u>	<u>48</u>	<u>13</u>	<u>7</u>	4	4	<u>11</u>	<u>9</u>	5	7	6	3	<u>12</u>			
2.5-10 (1-4)			11	<u>58</u>	<u>32</u>	18	7	<u>10</u>	<u>14</u>	<u>78</u>	<u>42</u>	2	<u>12</u>	<u>22</u>	<u>23</u>	<u>9</u>	<u>22</u>	<u>8</u>	<u>18</u>	<u>33</u>	<u>26</u>	<u>24</u>	<u>18</u>	<u>37</u>	<u>10</u>	<u>11</u>	<u>15</u>	<u>18</u>	<u>48</u>	42	42	<u>13</u>	<u>15</u>	5	4	<u>18</u>
		0.5	3	2	2	1	1	2	3	1	2	1	2	1	1	3	<u>8</u>	3	4	2	4	<u>8</u>	3	2	<u>43</u>	<u>10</u>	<u>8</u>	3	2	2	2	2				
		2	<u>12</u>	10	3	2	5	2	3	2	5	1	2	<u>7</u>	1	5	<u>22</u>	<u>8</u>	3	3	<u>12</u>	<u>20</u>	3	1	<u>39</u>	4	2	<u>6</u>	2	2	2	2				
		5.5	2	1	1	1	4	<u>10</u>	5	1	1	1	—	1	3	<u>8</u>	<u>7</u>	3	1	2	3	3	2	4	2	2	2	2	1	3	2	2				
		11	<u>13</u>	<u>9</u>	2	2	1	<u>6</u>	<u>7</u>	<u>9</u>	1	<u>7</u>	5	<u>7</u>	2	2	2	2	<u>19</u>	4	3	3	<u>7</u>	2	2	2	<u>6</u>	<u>6</u>	4	<u>10</u>	2	3	1	2	4	<u>7</u>

^aValues underlined and in bold type are elevated above those of preconstruction samples based on 95% tolerance level. See Tables I-10, I-11, and I-12 in text for preconstruction values. Control values can be found in Table I-26. Distances from boardwalk: a = 0 cm, b = 30 cm (12 in.), c = 60 cm (24 in.), d = 150 cm (59 in.), e = 3 m (10 ft).

Table I-26—CCA section: copper, chromium, and arsenic in sediment samples under boardwalk^a

Element	Sediment depth (cm (in.))	Time (mo)	Concentration in sediment samples (ppm)						Control ^b	
			U1	U2	U3	U4	U5	U6		
Cu	0–2.5 (0–1)	0.5	28	<u>37</u>	30	31	34	<u>50</u>	29, 24, 23, 19	
		2	<u>86</u>	<u>69</u>	<u>53</u>	<u>61</u>	<u>45</u>	<u>201</u>	24, 24, 26, 21	
		5.5	<u>219</u>	<u>146</u>	35	<u>65</u>	<u>153</u>	<u>78</u>	22, 23, 21, 15	
		11	<u>110</u>	<u>62</u>	<u>51</u>	<u>109</u>	34	<u>115</u>	30, <u>59</u> , 32, <u>53</u> , 27, 22, 27, 20, 18, <u>43</u>	
	2.5–10 (1–4)	0.5	26	29	22	23	21	24	25, 22, —, 37	
		2	<u>73</u>	—	22	<u>113</u>	<u>92</u>	<u>121</u>	20, 21, 21, 25	
		5.5	<u>59</u>	30	24	20	<u>38</u>	26	20, 21, 21, 24	
		11	<u>38</u>	24	<u>46</u>	25	23	<u>38</u>	23, 14, 13, 27, 20, 26, 16, 20, 25, 21	
	Cr	0–2.5 (0–1)	0.5	12	13	14	<u>16</u>	9	<u>23</u>	10, 9, 11, 6
			2	<u>34</u>	<u>29</u>	<u>24</u>	<u>24</u>	19	<u>104</u>	12, 10, 12, 8
			5.5	<u>55</u>	<u>30</u>	<u>15</u>	<u>23</u>	31	<u>22</u>	9, 11, 10, 8
			11	<u>37</u>	14	14	<u>25</u>	14	<u>37</u>	9, 10, 6, 9, 9, 9, 9, 10, 11, 8
2.5–10 (1–4)		0.5	11	14	9	8	8	8	9, 7, —, 10	
		2	<u>16</u>	<u>32</u>	8	<u>23</u>	—	<u>36</u>	9, 7, 9, 11	
		5.5	9	11	10	8	11	11	10, 9, 10, 9	
		11	10	7	13	8	6	14	10, 7, 6, 7, 4, 12, 6, 7, 11, 9	
As		0–2.5 (0–1)	0.5	6	<u>14</u>	8	<u>10</u>	<u>10</u>	<u>16</u>	4, 4, 3, 5
			2	<u>62</u>	<u>43</u>	<u>25</u>	<u>26</u>	<u>22</u>	<u>130</u>	2, 4, 3, 6
			5.5	<u>82</u>	<u>65</u>	<u>12</u>	<u>37</u>	<u>60</u>	<u>26</u>	3, 3, 2, 1
			11	<u>48</u>	<u>20</u>	<u>35</u>	<u>63</u>	<u>21</u>	<u>65</u>	2, 6, 1, 6, 5, 7, 1, 3, <u>9</u> , <u>10</u>
	2.5–10 (1–4)	0.5	3	<u>6</u>	1	3	<u>13</u>	2	1, 2, —, 2	
		2	<u>33</u>	<u>46</u>	3	<u>47</u>	—	<u>53</u>	1, 2, 1, 2	
		5.5	10	5	2	2	<u>8</u>	2	1, 1, 1, 1	
		11	<u>9</u>	3	11	2	4	<u>7</u>	2, 1, 1, 1, 2, 2, 1, 1, 1, 2	

^aValues underlined and in bold type are elevated above those of preconstruction samples based on 95% tolerance level. See Tables I-10, I-11, and I-12 in text for preconstruction values.

^bControl samples removed from upstream locations at minimum of 10 m (32 ft) from boardwalk.

Table I-27—ACZA section: copper, zinc, and arsenic in soil samples

Element	Soil depth (cm (in.))	Time (mo)	Concentration in soil samples (ppm) at various transects (1–7) and distances from boardwalk (a–d) ^a																												Control ^b
			1				2				3				4				5				6				7				
			a	b	c	d	a	b	c	d	a	b	c	d	a	b	c	d	a	b	c	d	a	b	c	d	a	b	c	d	
Cu	0–15	0.3	<u>111</u>	<u>37</u>	32	31	35	32	32	31	<u>36</u>	34	35	32	<u>43</u>	35	35	30	<u>45</u>	<u>36</u>	28	28	<u>37</u>	29	31	<u>42</u>	<u>48</u>	31	34	<u>53</u>	27, 23, 26, 25
	(0–6)	2.5	<u>82</u>	<u>55</u>	34	32	34	34	34	31	<u>54</u>	31	32	34	<u>40</u>	30	34	28	<u>56</u>	30	31	31	<u>42</u>	33	<u>40</u>	31	<u>50</u>	<u>56</u>	<u>50</u>	<u>48</u>	26, 25, 29, 27
		6	<u>36</u>	31	<u>37</u>	35	34	29	33	31	<u>51</u>	31	31	32	<u>43</u>	28	31	35	<u>110</u>	<u>46</u>	28	<u>36</u>	<u>107</u>	32	<u>38</u>	35	<u>150</u>	<u>38</u>	<u>40</u>	<u>64</u>	27, 27, 27, 32
		11.5	<u>459</u>	<u>43</u>	31	28	<u>432</u>	<u>40</u>	33	29	<u>37</u>	35	32	27	<u>149</u>	31	<u>43</u>	27	<u>126</u>	32	29	28	<u>72</u>	<u>93</u>	32	31	<u>109</u>	<u>122</u>	<u>58</u>	<u>41</u>	27, 28, 27, 25
	15–30	0.3	24	23	25	22	28	30	24	22	28	30	28	24	26	26	29	23	22	27	25	27	29	31	27	26	30	27	29	<u>44</u>	25, 27, 26, 31
	(6–12)	2.5	—	—	—	29	26	27	28	25	31	29	28	30	30	28	28	28	28	27	26	25	<u>39</u>	29	28	29	31	28	<u>120</u>	31	26, 29, 29, 27
		6	—	22	—	—	29	27	26	27	30	30	27	28	28	26	28	—	30	25	29	23	35	28	28	30	28	26	34	31	30, 29, 28, 28
	11.5	<u>79</u>	—	—	26	33	35	30	27	32	32	26	28	28	31	—	27	28	28	33	29	33	<u>72</u>	33	30	32	<u>204</u>	31	33	28, 29, 32, 35	
Zn	0–15	0.3	<u>87</u>	62	61	60	63	64	66	60	60	68	59	67	63	65	58	68	66	66	58	48	63	66	70	72	63	71	67	58, 50, 67, 54	
	(0–6)	2.5	63	59	57	59	57	56	58	59	62	56	58	62	53	56	59	56	64	52	56	61	60	62	61	58	62	59	66	68	55, 52, 67, 50
		6	64	68	<u>75</u>	<u>75</u>	65	56	68	68	70	62	67	71	69	53	63	72	<u>103</u>	<u>75</u>	67	<u>76</u>	<u>108</u>	68	<u>80</u>	<u>91</u>	<u>112</u>	74	73	<u>87</u>	52, 54, 64, 55
		11.5	<u>180</u>	64	55	59	<u>275</u>	63	63	55	62	60	61	47	<u>110</u>	<u>67</u>	66	39	<u>98</u>	64	61	59	<u>88</u>	<u>88</u>	59	61	<u>87</u>	61	<u>77</u>	73	59, 55, 67, 51
	15–30	0.3	48	46	49	50	57	56	52	48	55	56	53	48	47	45	49	44	46	55	50	53	50	55	57	49	55	47	58	60	53, 52, 42, 61
	(6–12)	2.5	—	—	—	54	60	62	55	48	56	57	55	55	65	63	47	54	53	63	57	49	51	61	51	49	54	61	<u>88</u>	52	55, 61, 48, 59
		6	—	48	—	—	50	51	48	48	48	51	46	30	45	42	45	—	52	45	30	26	50	49	43	28	49	43	39	48	57, 52, 45, 49
	11.5	70	—	—	56	56	<u>141</u>	56	57	58	56	50	52	50	57	—	48	56	52	52	54	56	65	58	57	57	<u>107</u>	<u>75</u>	55	51, 57, 52, 59	
As	0–15	0.5	7	4	2	4	4	3	3	4	4	3	2	4	3	4	3	3	6	4	1	3	3	3	2	6	3	2	3	6	2, 1, 1, 3
	(0–6)	2	1	1	1	2	1	1	1	1	1	1	1	1	1	1	1	2	1	1	0	1	1	1	1	1	1	1	1	2	3, 1, 1, 4
		5.5	<u>14</u>	<u>10</u>	<u>9</u>	6	1	6	5	<u>11</u>	8	6	<u>20</u>	1	8	4	7	5	<u>13</u>	<u>11</u>	4	4	<u>25</u>	<u>23</u>	2	<u>9</u>	<u>51</u>	<u>9</u>	6	<u>13</u>	3, 2, 1, 3
		11.5	<u>159</u>	<u>10</u>	<u>6</u>	4	<u>158</u>	<u>7</u>	<u>6</u>	5	<u>9</u>	6	<u>9</u>	4	<u>78</u>	8	<u>13</u>	5	<u>51</u>	1	5	4	<u>40</u>	<u>42</u>	7	4	<u>31</u>	<u>96</u>	<u>17</u>	<u>14</u>	3, 1, 5, 5
	15–30	0.3	3	3	4	4	4	4	3	3	4	4	3	3	4	4	4	4	3	4	4	5	3	4	3	4	4	4	4	<u>10</u>	3, 3, 4, 5
	(6–12)	2.5	—	—	—	3	3	5	3	2	3	5	3	2	5	4	3	3	3	4	2	2	<u>9</u>	4	3	3	3	4	<u>15</u>	3	5, 2, 4, 3
		6	—	2	—	—	4	4	5	4	4	4	4	4	5	3	4	—	4	4	5	3	<u>9</u>	5	3	4	5	3	5	4	4, 3, 3, 3
	11.5	<u>23</u>	—	—	5	5	5	6	4	6	5	4	3	<u>8</u>	4	—	3	<u>7</u>	4	5	5	<u>8</u>	<u>107</u>	<u>7</u>	4	<u>14</u>	<u>143</u>	5	<u>9</u>	3, 3, 4, 4	

^aValues underlined and in bold type are elevated above those of preconstruction samples based on 95% tolerance level. See Tables I-14, I-15, and I-16 in text for preconstruction values.

Distances from boardwalk: a = 0 cm, b = 15 cm (6 in.), c = 30 cm (12 in.), d = 60 cm (24 in.).

^bControl samples removed minimum of 3 m (10 ft) from boardwalk

Table I-28—ACZA section: copper, zinc, and arsenic in sediment samples

Element	Sediment depth (cm (in.))	Time (mo)	Concentration in sediment samples (ppm) at various transects (1-7) and distances from boardwalk (a-e) ^a																																		
			1					2					3					4					5					6					7				
			a	b	c	d	e	a	b	c	d	e	a	b	c	d	e	a	b	c	d	e	a	b	c	d	e	a	b	c	d	e	a	b	c	d	e
Cu	0-2.5	0.3	77	44	81	18	—	104	28	22	30	—	23	20	20	20	—	26	19	24	20	—	28	22	22	18	—	23	64	112	24	—	48	51	51	21	—
	(0-1)	2.5	434	57	24	72	—	29	27	52	226	—	37	53	30	22	—	30	30	27	48	—	47	31	28	19	—	63	122	85	35	—	569	30	32	29	—
		6	31	41	20	34	—	49	39	29	22	—	22	25	23	22	—	18	20	21	18	—	25	33	20	11	—	85	64	47	30	—	208	54	31	20	—
		11.5	290	130	33	34	20	34	35	40	32	17	28	32	30	23	17	47	20	20	23	16	88	83	24	25	25	91	39	29	25	23	136	58	27	35	25
	2.5-10	0.3	—	29	24	22	—	32	24	19	22	—	22	21	24	21	—	21	21	19	22	v	24	23	22	23	—	21	24	32	20	—	24	34	20	20	—
	(1-4)	2.5	25	21	34	26	—	21	20	22	24	—	20	23	19	20	—	17	17	19	20	—	43	20	20	20	—	50	146	114	19	—	98	26	21	22	—
		6	23	26	23	22	—	28	22	21	23	—	23	31	24	23	—	25	19	22	25	—	23	23	25	23	—	29	—	—	—	—	20	—	—	—	—
		11.5	53	39	40	27	23	54	28	25	25	21	24	26	23	21	20	24	23	20	20	23	33	51	22	26	23	43	64	29	32	20	180	63	43	19	27
Zn	0-2.5	0.3	124	77	104	55	—	136	72	54	109	—	64	61	54	52	—	99	48	55	48	—	68	56	57	55	—	60	102	133	47	—	108	93	88	57	—
	(0-1)	2.5	1,048	110	83	167	—	73	66	96	108	—	691	121	79	55	—	59	74	58	70	—	114	73	66	49	—	90	177	110	63	—	617	67	66	55	—
		6	98	86	60	87	—	103	105	78	74	—	66	82	64	61	—	50	55	63	57	—	102	104	53	41	—	89	96	109	61	—	170	86	67	54	—
		11.5	219	191	118	126	66	88	85	89	79	53	98	159	92	59	55	74	57	50	63	46	354	198	62	65	68	106	93	73	62	74	167	160	73	88	65
	2.5-10	0.3	—	71	59	60	—	78	63	48	57	—	65	52	56	47	—	58	47	38	49	—	56	56	62	56	—	50	68	69	44	—	73	66	52	52	—
	(1-4)	2.5	55	87	119	60	—	43	51	45	50	—	90	52	45	42	—	41	40	44	44	—	78	47	60	44	—	107	187	61	53	—	131	63	52	62	—
		6	63	60	57	64	—	49	52	65	61	—	53	54	61	56	—	47	49	53	55	—	48	56	51	61	—	55	—	—	—	—	317	—	—	—	—
		11.5	246	67	127	88	55	86	59	67	59	50	52	180	59	53	53	57	55	43	47	53	307	114	36	51	57	79	90	65	61	51	626	289	49	52	63
As	0-2.5	0.3	13	7	15	4	—	15	3	2	5	—	3	3	2	2	—	4	2	4	3	—	5	4	2	2	—	5	14	24	7	—	24	12	10	4	—
	(0-1)	2.5	15	9	3	13	—	6	4	7	14	—	5	5	3	2	—	6	4	4	9	—	7	5	4	2	—	13	27	27	6	—	53	8	6	5	—
		6	5	2	2	5	—	9	8	3	2	—	2	5	2	3	—	3	3	2	2	—	3	3	1	0	—	26	16	5	6	—	56	9	49	3	—
		11.5	16	6	3	5	2	3	5	6	4	2	5	1	3	1	1	9	2	3	2	3	23	18	3	1	3	21	9	6	3	2	46	19	3	3	2
	2.5-10	0.3	—	4	2	2	—	3	3	7	2	—	2	1	2	2	—	2	3	1	2	—	3	2	2	2	—	2	3	6	2	—	3	4	2	2	—
	(1-4)	2.5	2	1	6	2	—	3	1	3	3	—	1	1	1	1	—	1	1	1	1	—	3	1	1	1	—	7	18	16	2	—	14	4	2	2	—
		6	2	2	2	2	—	3	2	2	7	—	2	2	2	2	—	2	2	2	2	—	2	2	2	1	—	3	—	—	—	—	11	—	—	—	—
		11.5	3	2	3	3	2	5	2	2	1	1	2	2	3	1	3	2	2	1	1	2	4	5	1	2	2	11	13	6	5	2	82	27	3	2	4

^aValues underlined and in bold type are elevated above those of preconstruction samples based on 95% tolerance level. See Tables I-17 – I-20 in text for preconstruction values. Control values can be found in Table I-29. Distances from boardwalk: a = 0 cm, b = 30 cm (12 in.), c = 60 cm (24 in.), d = 150 cm (59 in.), e = 3 m (10 ft).

Table I-29—Control values for ACZA sediment samples^a

Element	Sediment depth (cm (in.))	Time (mo)	Control		
Cu	0-2.5 (0-1)	0.3	22, 22, 23, 26		
		2.5	—, 18, 19, 24		
		6	19, 18, 20, 20		
		11.5	19, 16, 18, 22, 18, 17		
	2.5-10 (1-4)	0.3	17, 24, 24, 21		
		2.5	17, 21, 26, 23		
		6	22, 18, 25, 25		
		11.5	24, 21, 26, 23, 25, 21		
		Zn	0-2.5 (0-1)	0.3	55, 57, 58, 62
				2.5	—, 45, 48, 68
6	57, 45, 53, 53				
11.5	53, 47, 53, 59, 50, 44				
2.5-10 (1-4)	0.3		47, 50, 55, 58		
	2.5		45, 45, 51, 59		
	6		61, 42, 47, 56		
	11.5		49, 61, 41, 55, 57, 53		
	As		0-2.5 (0-1)	0.3	2, 3, 5, 5
				2.5	—, 3, 2, 1
6		2, 3, 2, 2			
11.5		2, 2, 2, 4, 4, 4			
2.5-10 (1-4)		0.3	1, 3, 2, 2		
		2.5	1, 2, 1, 3		
		6	2, 1, 1, 2		
		11.5	1, 1, 1, 2, 3, 2		

^aControl samples removed from upstream locations at minimum of 10 m (32 ft) from boardwalk.

Table I-30—ACQ-B section: copper in soil and sediment samples

Sample depth (cm (in.))	Time (mo)	Concentration in samples (ppm) at various transects (1-7) and distances from boardwalk (a-e) ^a																									Control ^b										
		1					2					3					4					5						6					7				
		a	b	c	d	e	a	b	c	d	e	a	b	c	d	e	a	b	c	d	e	a	b	c	d	e		a	b	c	d	e					
Soil samples																																					
0-15	0.3	<u>88</u>	30	<u>34</u>	<u>37</u>	<u>252</u>	<u>34</u>	<u>48</u>	<u>38</u>	<u>45</u>	32	27	28	<u>53</u>	31	29	31	<u>48</u>	<u>34</u>	<u>42</u>	31	<u>153</u>	<u>45</u>	<u>37</u>	28	—	<u>36</u>	27	30	23, 21, 19, 25							
(0-6)	2.5	<u>192</u>	—	—	—	<u>106</u>	30	<u>40</u>	33	<u>58</u>	32	<u>36</u>	<u>35</u>	<u>253</u>	32	<u>44</u>	<u>39</u>	<u>136</u>	<u>38</u>	<u>58</u>	<u>37</u>	<u>288</u>	<u>52</u>	32	31	<u>144</u>	<u>51</u>	25	<u>44</u>	24, 21, 17, 25							
	6.0	—	<u>54</u>	<u>48</u>	27	<u>354</u>	<u>56</u>	<u>34</u>	<u>35</u>	<u>106</u>	<u>34</u>	32	27	<u>1,943</u>	<u>43</u>	<u>38</u>	22	<u>122</u>	<u>62</u>	<u>48</u>	27	<u>209</u>	30	24	26	<u>2,158</u>	<u>94</u>	<u>35</u>	20	25, 24, 18, 28							
	11.5	<u>157</u>	<u>52</u>	<u>206</u>	<u>41</u>	<u>534</u>	<u>80</u>	30	<u>57</u>	<u>49</u>	<u>69</u>	<u>56</u>	<u>66</u>	<u>319</u>	<u>68</u>	27	26	<u>567</u>	<u>108</u>	<u>60</u>	<u>46</u>	<u>400</u>	33	<u>77</u>	29	<u>1,894</u>	<u>164</u>	<u>108</u>	<u>42</u>	27, 20, 18, 25							
15-30	0.3	24	24	23	25	<u>37</u>	22	24	26	22	23	22	25	26	25	23	26	30	23	24	24	35	23	22	26	—	24	22	25	24, —, 21, —							
(6-12)	2.5	—	—	—	—	—	—	—	25	—	—	—	28	—	—	—	27	—	—	—	22	—	—	—	23	—	—	—	23	23, —, 24, 23							
	6.0	23	24	—	23	32	22	26	24	22	—	22	22	<u>52</u>	23	22	22	27	23	22	21	30	—	—	21	<u>73</u>	27	22	22	22, —, 16, 23							
	11.5	34	<u>36</u>	32	23	<u>66</u>	24	21	24	—	20	21	30	—	25	21	21	<u>70</u>	23	<u>39</u>	23	<u>434</u>	20	21	21	—	<u>86</u>	27	22	22, —, 21, 20							
Sediment samples																																					
0-2.5	0.3	<u>36</u>	<u>38</u>	<u>76</u>	23	—	23	20	22	<u>40</u>	—	23	27	27	21	—	<u>46</u>	<u>39</u>	<u>37</u>	24	—	24	21	24	24	—	29	33	21	<u>35</u>	—	31	20	41	<u>39</u>	—	25, 18, 18, 23
(0-1)	2.5	<u>47</u>	<u>49</u>	—	25	—	34	24	26	23	—	29	33	25	24	—	<u>139</u>	33	30	28	—	25	21	22	<u>35</u>	—	<u>38</u>	23	18	28	—	32	<u>42</u>	21	25	—	18, 19, 22, 16
	6.0	<u>77</u>	23	<u>78</u>	<u>74</u>	—	<u>48</u>	<u>40</u>	<u>41</u>	<u>56</u>	—	<u>427</u>	<u>38</u>	28	<u>51</u>	—	<u>341</u>	<u>83</u>	30	<u>44</u>	—	<u>45</u>	<u>52</u>	<u>54</u>	31	—	<u>127</u>	<u>183</u>	<u>47</u>	<u>54</u>	—	<u>74</u>	<u>145</u>	<u>74</u>	<u>38</u>	—	19, 22, 17, 21
	11.5	<u>90</u>	<u>41</u>	<u>49</u>	<u>75</u>	<u>37</u>	<u>122</u>	<u>45</u>	<u>36</u>	<u>41</u>	24	<u>105</u>	31	<u>99</u>	22	22	<u>81</u>	<u>74</u>	24	<u>37</u>	<u>36</u>	<u>52</u>	<u>43</u>	31	<u>70</u>	<u>65</u>	<u>111</u>	<u>48</u>	30	<u>34</u>	26	<u>65</u>	<u>114</u>	<u>70</u>	23	30	23, 21, 20, 18, 19, 17, 23, 15, 22, 24
2.5-10	0.3	26	21	24	20	—	23	22	23	26	—	24	20	22	25	—	27	21	21	23	—	22	21	29	25	—	20	25	20	15	—	20	19	22	18	—	22, 14, 20, 21
(1-4)	2.5	27	24	20	37	—	23	22	21	17	—	22	26	21	22	—	23	21	24	23	—	18	21	24	27	—	—	24	19	18	—	18	18	19	17	—	23, 18, 26, 21
	6.0	37	23	26	22	—	24	24	22	22	—	<u>166</u>	27	25	21	—	<u>78</u>	23	21	23	—	19	19	23	19	—	22	31	19	22	—	24	19	23	18	—	23, 23, 17, 19
	11.5	<u>132</u>	31	18	33	36	<u>55</u>	—	21	23	20	27	21	<u>54</u>	25	21	27	25	18	18	21	33	22	22	26	33	23	20	20	27	21	<u>46</u>	22	31	20	17	23, 20, 25, 19, 20, 19, 22, 22, 19, 23

^aValues underlined and in bold type are elevated above those of preconstruction samples based on 95% tolerance level. See Tables I-21 and I-22 in text for preconstruction values. Distances from boardwalk: a = 0 cm, b = 15 cm (6 in.), c = 30 cm (12 in.), d = 60 cm (24 in.), e = 300 cm (118 in.). Samples at 300 cm (118 in.) from boardwalk were removed at 11.5 months only.

^bSoil control samples removed at minimum of 3 m (10 ft) from boardwalk; sediment control samples removed from upstream locations at minimum of 10 m (32 ft) from boardwalk..

Note: four values for soil samples (a-d), five values for sediment (a-e).

Table I-31—CDDC section: copper in soil samples

Soil depth (cm (in.))	Time (mo)	Concentration in samples (ppm at various transects (1–15) and distances from boardwalk (a–d) ^a																															
		1				2				3				4				5				6				7				8			
		a	b	c	d	a	b	c	d	a	b	c	d	a	b	c	d	a	b	c	d	a	b	c	d	a	b	c	d	a	b	c	d
0–15	0.5	32	28	28	28	24	24	27	25	23	25	26	30	25	25	26	27	26	26	26	26	27	25	28	29	28	28	27	28	31	26	24	27
(0–6)	2	<u>37</u>	26	28	27	24	24	24	23	34	23	24	24	26	23	24	28	30	26	25	24	29	25	24	27	30	30	27	19	<u>48</u>	<u>35</u>	28	33
	5.5	34	31	32	25	<u>42</u>	<u>41</u>	21	26	32	27	22	27	34	26	23	26	32	29	21	30	33	21	22	25	<u>38</u>	22	19	23	<u>49</u>	31	23	29
	11	<u>125</u>	31	33	28	<u>186</u>	<u>42</u>	27	28	<u>153</u>	<u>35</u>	29	27	<u>83</u>	<u>39</u>	25	26	<u>98</u>	30	33	28	29	28	32	33	<u>107</u>	34	29	29	<u>107</u>	<u>74</u>	26	30
15–30	0.5	28	—	—	28	26	26	28	28	21	25	27	29	25	26	—	26	25	26	29	29	29	28	—	29	29	31	—	32	—	26	25	32
(6–12)	2	28	—	31	30	24	27	27	25	24	26	25	29	25	29	30	25	23	23	29	29	26	24	—	31	31	30	31	—	25	27	27	25
	5.5	23	—	27	<u>37</u>	22	—	21	34	27	21	24	27	32	21	23	27	—	—	21	28	26	—	25	33	29	24	23	26	<u>54</u>	26	25	31
	11	<u>40</u>	—	—	27	—	<u>36</u>	<u>37</u>	25	33	28	22	27	34	<u>40</u>	26	22	<u>65</u>	22	24	25	<u>37</u>	32	—	27	32	35	29	28	23	<u>41</u>	27	31
		9				10				11				12				13				14				15				Control ^b			
		a	b	c	d	a	b	c	d	a	b	c	d	a	b	c	d	a	b	c	d	a	b	c	d	a	b	c	d				
0–15	0.5	<u>49</u>	25	24	<u>35</u>	<u>46</u>	23	24	27	28	25	26	26	32	24	26	27	31	25	29	27	22	23	23	23	23	22	22	25	23, 33, 24, 31			
(0–6)	2	<u>36</u>	26	20	22	<u>105</u>	25	24	23	34	26	22	20	34	25	26	23	28	24	29	28	25	23	22	22	<u>49</u>	25	20	20	24, 21, 21, 24			
	5.5	<u>93</u>	29	28	32	<u>120</u>	25	22	22	31	31	26	23	<u>71</u>	26	26	25	<u>77</u>	28	29	29	21	23	25	23	<u>89</u>	33	22	27	19, 19, 24, 30			
	11	<u>179</u>	30	29	29	<u>520</u>	25	26	25	<u>346</u>	30	34	24	<u>620</u>	<u>75</u>	<u>35</u>	26	<u>388</u>	<u>35</u>	34	31	<u>201</u>	23	23	28	<u>49</u>	<u>90</u>	31	28	24, 23, 30, 24			
15–30	0.5	—	—	27	—	—	24	—	—	—	26	28	—	—	25	—	27	—	—	28	28	—	31	31	26	30	25	24	30	252, 32, 28			
(6–12)	2	—	23	—	—	—	—	—	22	29	28	—	—	—	—	—	—	27	27	25	24	29	31	27	28	27	26	23	27	33, 26			
	5.5	25	24	—	32	24	22	—	22	30	26	—	23	33	23	—	24	29	29	—	29	—	31	—	29	30	—	—	—	20, 32			
	11	34	28	26	—	<u>69</u>	25	23	22	32	30	29	—	<u>89</u>	<u>52</u>	28	26	33	31	29	26	<u>57</u>	28	27	29	<u>44</u>	<u>47</u>	27	22	31, 32			

^aValues underlined and in bold type are elevated above those of preconstruction samples based on 95% tolerance level. See Table I-23 in text for preconstruction values. Distances from boardwalk: a = 0 cm, b = 15 cm (6 in.), c = 30 cm (12 in.), d = 60 cm (24 in).

^bSamples removed at minimum of 3 m (10 ft) from boardwalk

Part II. Environmental Effects

Kenneth M. Brooks

Summary

Part II of this study documents the response of aquatic invertebrates to the effects of wetland boardwalks treated with chromated copper arsenate, ammoniacal copper zinc arsenate, and ammoniacal copper quat. This aspect of the study was designed to assess changes in invertebrate communities under the worst possible conditions: large surface areas of treated wood located in and adjacent to water of low hardness and alkalinity that flows very slowly over fine-grained sediments. The experimental variables were total species richness (total number of taxa), total sample abundance (number of organisms/sample), dominant sample abundance ($\geq 1\%$ total specimens in vegetation, artificial substrate, and infaunal samples), and Shannon's and Pielou's indices. The infaunal samples contained the largest mean number of animals and the highest total taxa richness. Although measurable increases occurred in water column and sediment preservative concentrations, no taxa were excluded or significantly reduced in number by any preservative treatment.

Contents

	<i>Page</i>
Introduction	73
Background Levels and Sources of Copper in Aquatic Environments.....	73
Cycling and Fate of Copper in Aquatic Environments	74
Cycling of Sediment Copper as Function of REDOX Potential.....	74
Bioaccumulation of Copper by Aquatic Organisms	75
Copper Toxicity.....	76
Benchmarks for Copper in Marine and Freshwater Sediments	84
Background of Wildwood Boardwalk Study	88
Materials and Methods	88
Site Selection.....	90
Treatment Sites	90
Sampling Procedures	91
Analytical Procedures.....	93
Study Endpoints.....	94
Results	95
Characterization of Study Area.....	95
Invertebrate Community—Baseline Survey	98
Invertebrate Community—Mechanical Control.....	101
Results for ACQ–B-Site	103
Results for ACZA Site.....	109
Results for CCA–C Site.....	112
Summary of Wildwood Boardwalk Study	119
Acknowledgments	121
References	121
Appendix—Terms for Variables and Inventory of Taxa.....	125

Part II. Environmental Effects

Kenneth M. Brooks, Owner and Principal Scientist
Aquatic Environmental Sciences, Port Townsend, Washington

Introduction

Waterborne wood preservatives have been used since 1933 when chromated copper arsenate (CCA) was introduced. This preservative has been used for more than 60 years to extend the life of a number of species of wood. CCA-C preservative contains approximately 47.5% hexavalent chromium as CrO_3 , 18.5% copper as CuO , and 34.0% arsenic as As_2O_5 . The copper and arsenic function as biocides. Chromium is added to reduce corrosion and to fix the copper and arsenic through formation of insoluble precipitates. The loss of metals from CCA-C-treated wood is predictable and models describing their loss are available (Brooks 1995, 1996). CCA-C is very effective in preserving southern yellow pine (*Pinus* sp.) and has found extensive use where wood is exposed to the weather or immersed in fresh or salt water. CCA-C-treated wood intended for immersion in fresh water is treated to a retention of 6.4 kg preservative/ m^3 of wood in the treated zone. The treated zone generally extends to a depth of 10 to 13 mm or 90% of the sapwood (AWPA 1996).

Douglas-fir (*Pseudotsuga menziesii*) is somewhat refractory to preservation with CCA-C. Chemonite is a waterborne wood preservative developed at the University of California by Dr. Aaron Gordon in the 1920s. It was first used to commercially treat Douglas-fir in 1934. The original formulation was called ACA. In 1983, the formulation was changed to ammoniacal copper zinc arsenate (ACZA) with a chemical ratio of 50% copper oxide, 25% arsenic pentoxide, and 25% zinc oxide. Ammonia is included in the formulation to solubilize the metals, facilitating their chemical bonding to wood carbohydrates. In the study reported here, the Douglas-fir used in the ACZA test section was treated to 0.70 kg/ m^3 (see Part I). Brooks (1997a) has described metal losses from ACZA-treated wood.

Ammoniacal copper quat (ACQ-B) was developed and patented in Canada (Findlay and Richardson 1983, 1990). This preservative contains between 62% and 71% copper oxide (CuO) and between 29% and 38% quat as didecyl-dimethylammonium chloride (DDAC). These active ingredients are dissolved in a water carrier to which is added ammonia (NH_3) equal to or greater in weight than the copper oxide. The quaternary ammonium compound in ACQ-B fixes in wood through ion exchange with anionic active sites and through other adsorption mechanisms at higher quat concentrations (Archer and others 1992). Wood intended for use in aquatic environments is treated to a retention of 6.4 kg/ m^3

(AWPA 1996). Brooks (1998) has described copper losses from ACQ-B-treated southern yellow pine immersed in fresh water.

Brooks (1995, 1996, 1997a-c, 1998) has documented the environmental risks associated with the use of each of these preservatives and has provided computer models that can be used to predict environmental levels of preservative constituents lost from immersed wood. In each case, it has been clearly demonstrated that copper is the metal of concern. If the concentration of copper is maintained at or below copper criteria set by the Environmental Protection Agency (EPA) for surface waters, then the concentrations of arsenic, chrome, zinc, and DDAC will be well below levels associated with biological effects defined in regulatory standards.

Background Levels and Sources of Copper in Aquatic Environments

The following discussion is intended to provide background against which to evaluate metal levels observed in the Wildwood study area before and after installation of the treated wood boardwalk.

Copper is a naturally occurring element found in all aquatic systems. At low levels, it is considered a micronutrient essential to the proper functioning of plants and animals. Copper levels of 1 to 10 $\mu\text{g/L}$ were reported by Boyle (1979) from unpolluted waters of the United States. However, concentrations downstream of municipal and industrial outfalls may be much higher (Hutchinson 1979). Background levels of 1 to 3 $\mu\text{g Cu/L}$ were observed by the U.S. Geological Survey between 1995 and 1997 in the Columbia River, with a mean level of 2.00 $\mu\text{g Cu/L}$. The lower Columbia River carries approximately 650 kg of copper past any point every day at a concentration of 2.0 $\mu\text{g/L}$.

Background levels of copper in lower Columbia River sediments range between 18 and 66 mg/kg (Siipola 1991). Similarly, Tetra Tech (1994) observed sediment copper concentrations ranging from 19.3 to 49.9 mg/kg in the Columbia River, with a median concentration of 27.6 mg/kg. Munkittrick and others (1991) reported reference area sediment copper concentrations of 4 to 23 mg/kg in northern Ontario. Cairns and others (1984) reported copper levels of 59 mg/kg in control sediments from the Tualatin River, Oregon, and 210 mg/kg in control sediments from Soap Creek Pond at Oregon State University.

Crocket and Kabir (1981) observed widespread increases in copper concentrations in the upper 5 cm of sediments from the Sudbury–Temagami area in Ontario to about 50 to 75 mg Cu/kg dry sediment weight. They associated these increases with atmospheric deposition from the nearby Sudbury industrial complex. Hupp and others (1993) observed sedimented copper concentrations of 3 to 24 mg/kg along the Chickahominy River in Virginia. Highest levels of sedimented copper were associated with the most urban–industrial part of the river basin. Their data indicated that 17,170,000 kg of sediment was deposited in wetlands along the Chickahominy River each year and that the annual deposition of copper to these sediments was 176 kg. Larsen (1983) estimated a mean annual atmospheric copper deposition rate of 1.81 to 2.77 mg/m² at four Danish lakes. Larsen (1983) cites Hovmand's (1979) finding that 10% to 60% of the heavy metal loading to the Baltic Sea is from atmospheric deposition and measured copper concentrations in rainwater vary between 1.79 and 2.49 µg/L.

These data suggest that background levels of sedimented copper can vary significantly at sites unaffected by identifiable sources of pollution. Background levels appear to vary from less than 10 mg Cu/kg dry sediment weight to perhaps 70 to 200 mg Cu/kg. It also appears reasonable to conclude that atmospheric deposition is a significant source of copper over large areas.

Cycling and Fate of Copper in Aquatic Environments

Copper occurs in soft natural waters primarily as the divalent cupric ion. It may be found as a free ion or complexed with humic acids, carbonate, or other inorganic and organic molecules in water of increasing hardness. Copper is an essential element in the normal metabolism of both plants and animals. Therefore, a significant portion of the copper found in both fresh and marine systems may be taken up by the biota. The ultimate fate of much of this copper is sedimentation.

Harrison and others (1987) found very low copper levels (<12 mg/kg) in sandy substrates associated with power plant effluents and suggested that the lack of organic matter in these sediments was responsible for the low copper content. In contrast, Kerrison and others (1988) found that copper added to enclosures placed in a shallow fertile lake rapidly became associated with suspended particulate material in the water column. The environment in which these experiments was conducted suggests that the particulate matter consisted of particulate organic matter (POM) and/or particulate inorganic matter (PIM), which would most likely be in the form of clay particles. Little suspended silt would be anticipated in a shallow freshwater lake.

Clarke (1974) noted that iron sulfide will render copper insoluble in anaerobic sediments. This report suggests that

copper accumulation in sediments is highly influenced by sediment chemistry and physical characteristics. Fine sediments, coupled with poor water circulation, could be expected to accumulate more copper than would coarse sediments in highly oxygenated areas. Copper accumulations in fine-grained, anaerobic sediments are probably not biologically available; thus these environments may serve as an important mechanism for the removal of excess copper from aquatic environments.

Schmidt (1978) reported that the average copper level in open ocean water was approximately 1.15 µg/L, with a rather broad range of 0.06 to 6.7 µg/L. Copper levels in coastal and near-shore water were higher, with a mean of 2.0 µg/L. In near-shore water, more copper was found bound to particulate material (50.7%) than complexed in a dissolved form (49.3%). In open-sea samples, copper was partitioned between particulate (34.8%) and dissolved (65.2%) compartments. Schmidt (1978) reported that much of the copper in near-shore and offshore waters was associated with particulate material and that approximately 10% was adsorbed to clay. The average concentration of copper in suspended particulate material in the ocean was 109 µg/g, with a range of 52 to 202 µg/g. Schmidt noted that these levels were higher than those found in most near-shore sediments. He suggested that fine suspended particulates, rich in copper, are probably an important medium for transporting continentally derived copper from the near shore to pelagic areas where the final repository for copper is likely in deep ocean sediments.

Cycling of Sediment Copper as Function of REDOX Potential

Lu and Chen (1976) examined the release of copper from sediments as a function of sediment grain size and oxygen availability. Sediment grain size was not a factor in the amount of copper released to the overlying water column. Three oxidizing conditions were examined: oxidizing, 5 to 8 ppm dissolved oxygen; slightly oxidizing, ≤1 ppm dissolved oxygen; and reducing, $S(-II)T = 15$ to 30 ppm). Small amounts of bound copper were released from sediments into the overlying water in reducing and slightly oxidizing environments (0.2 to 0.5 µg/L). Copper releases in the oxidizing environment resulted in significantly higher interfacial seawater concentrations (3.2 µg/L). This effect was slightly more pronounced in the coarsest sediment tested (silty sand sediment). These data imply higher copper releases from sediments in aerobic (biologically healthy) environments.

There are two ways to look at these results. First, in coarse-grained, highly oxygenated sediments, bound copper is more easily lost to the water column and dispersed over greater distances. Eventually, most copper will be deposited in areas with anaerobic sediments, where it is buried and incorporated into the lithosphere. These anaerobic sediments support

reduced infaunal and epifaunal communities of organisms. As a result, reduced environmental impacts from copper incorporated into these sediments, even at high levels, might be expected.

Second, for enclosed bodies of water with coarse-grained, aerobic sediments, this review suggests that copper will not be as tightly bound to the sediments and will cycle between sediments and interstitial and surficial waters where it is bioavailable. No data were provided on the copper species released from the sediments, and therefore it is difficult to assess the toxicity of the released copper in this scenario. However, the biological effects associated with copper in this environment would certainly be more significant than those associated with depauperate, anaerobic sediments.

The work of Lu and Chen (1976) suggests that caution is appropriate when dealing with copper in poorly flushed embayments with aerobic (>2 to 3 ppm dissolved oxygen) sediments. These arguments support the hypothesis that anaerobic sediments are a more efficient trap for released copper. Reduced environmental risks should be anticipated from copper releases associated with anaerobic sediments compared with those associated with aerobic sediments.

Bioaccumulation of Copper by Aquatic Organisms

Copper is an essential micronutrient for plants and animals. It can accumulate in organisms from the water column (bioconcentration), from sediments (bioaccumulation), or in the food chain (biomagnification). Its uptake and excretion are normal biological processes. Research has indicated that copper is bioconcentrated at moderately high levels from the water column. It is not significantly bioconcentrated from sediments. No evidence of copper biomagnification was obtained.

Copper Bioconcentration

The National Academy of Sciences (NAS 1971) provides copper bioconcentration factors (BCFs) for numerous taxa. These values range from 100× for benthic algae to 30,000× for phytoplankton. Marine mollusks concentrate copper by a factor of 5,000 in muscle and soft parts. Anderson (1977) reported metal BCFs in six species of freshwater clams from the Fox River in Illinois and Wisconsin. He found that soft tissues contained levels of copper equivalent to those found in sediments, which were significantly higher than those in the water column. Anderson (1977) reported water column concentrations of copper at 0.001 to 0.006 µg/L or 1 to 6 parts per trillion ($\times 10^{12}$). This appears to be low by a factor of 1,000 and these data appear suspect. Assuming that these reported water column concentrations are in error by a factor of 1,000, a comparison of the mean copper soft tissue burden (12.24 µg/g dry tissue weight) with the mean water column copper concentration (0.0035 mg/L) implies a BCF of 3,497.

This value is consistent with the NAS (1971) copper BCF for bivalve mollusks. Hendriks (1995) observed that dry weight corrected concentrations of copper in freshwater plants and invertebrates from the Rhine Delta were 0.2 to 0.3× the concentrations observed in suspended sediments, which suggests that copper adsorbed to suspended sediments is not readily bioconcentrated.

Marquenie and Simmers (1987) examined metal and polycyclic aromatic hydrocarbon levels in sediments and earthworms (*Eisenia foetida*) at an artificial wetland site created on a confined dredged material disposal facility that became a prolific wildlife habitat. At the six sites examined, they found an average copper concentration of 192.5 ± 107.6 µg Cu/g (dry weight) in soils. At the end of about 49 days, *Eisenia foetida* contained an average of 36.3 ± 14.9 µg Cu/g (ash-free tissue weight), suggesting that much of the sedimented copper was not biologically available (BCF = 0.19). Control earthworms, collected outside the dredge disposal site where soil copper levels averaged 16.5 µg/g, contained an average of 10.1 µg Cu/g, giving a BCF of 0.61 (3× higher). It is possible that 49 days was an insufficient period for annelid tissue to come into equilibrium with the high environmental levels of copper. Alternatively, it is also possible that *Eisenia foetida* is able to regulate copper uptake.

Rai and others (1995) examined metal uptake from pond water amended with 1.338 µM (84 ppm) copper in eight species of submerged macrophytes. No acute effects were observed, although several plant species did not increase biomass. At the end of 15 days, the plants had removed significant quantities of metal from the pond water and the BCFs given in Table II-1 were calculated.

Copper uptake from the water column varied considerably, with BCFs ranging from 211 in *Hygrophysa aristata* to 53,333 in *Ceratophyllum demersum*. This study (Rai and others 1995) demonstrates high but variable copper BCFs in several plant species and demonstrates the potential for plants to remove copper from stormwater in retention ponds or biofiltration swales. However, it is difficult to extrapolate the results to natural environments where elevated copper levels would likely be less than 15 to 20 µg/L rather than the 84,000 µg/L used in the study.

Copper Biomagnification

Little information was found on the biomagnification of copper by aquatic organisms. Van Eeden and Schoonbee (1993) examined copper levels in sediments, fennel-leaved pondweed, and various organs of the red-knobbed coot associated with a metal-contaminated wetland in South Africa. These researchers found that the pondweed contained less than half the copper level found in sediments. Copper levels in the various organs of the coot were similar to those in the

Table II-1—Metal bioconcentration factors (dimensionless) for submerged aquatic plants^a

Plant	BCFs for various metals					
	Cu	Cr	Fe	Mn	Cd	Pb
<i>Hydrodictyon reticulatum</i>	2,481	11,394	37,666	8,712	6,250	5,000
<i>Spirodela polyrrhiza</i>	36,500	7,920	3,878	3,107	5,750	2,521
<i>Chara carallina</i>	1,103	2,081	3,029	2,030	2,125	2,133
<i>Ceratophyllum demersum</i>	53,333	15,332	37,809	21,600	3,333	8,064
<i>Vallisneria spiralis</i>	2,009	1,993	1,344	333	2,375	1,777
<i>Bacopa moonieri</i>	18,750	2,016	2,041	2,487	29,000	366
<i>Alternanthera sessilis</i>	1,051	722	1,156	6,395	23,000	555
<i>Hygrorrhiza aristata</i>	211	652	1,138	1,955	4,600	7,174

^aRai and others 1995. BCF is bioconcentration factor.

pondweed, except that very little copper was transferred to eggs (shell or contents) of this bird. For the purposes of this paper, it will be assumed that copper accumulation in aquatic organisms is primarily a function of metal concentration in the ambient water. While many organisms may bioconcentrate copper, the available information suggests that copper is not biomagnified through food webs. The two processes (bioconcentration and biomagnification) are not necessarily directly related. Many materials are bioconcentrated, particularly by bivalves. However, many of those bioconcentrated substances are not biomagnified because they are either rapidly excreted or metabolized.

Copper Toxicity

To assess the potential impacts associated with treated wood used in aquatic environments, it is necessary to determine the minimum levels of copper that cause acute or chronic stress in fauna and flora. Copper is an essential element for most living organisms. It is added at a concentration of 2.5 µg/L in Guillard's medium F/2 to sea water for the optimum culture of marine algae (Strathman 1987). At concentrations slightly above those required as a micronutrient, copper can be highly toxic, especially to juvenile organisms.

Fresh Water

According to EPA ambient water quality criteria, copper toxicity in aquatic environments is related to the concentration of cupric (Cu²⁺) ions and perhaps copper hydroxides (CuOHn) (U.S. EPA 1985). The cupric ion is highly reactive and forms various copper complexes and precipitates that are significantly less toxic than the cupric ion (Knezovich and others 1981). Harrison and others (1987) reported that copper discharged from the San Onofre power plant cooling system was found mostly in bound forms under normal operating conditions. They found sufficient organic ligands available in ambient sea water to complex most of the copper, and they expected little or no impact from the discharges.

Likewise, Nuria and others (1995) and Kerrison and others (1988) observed that copper in freshwater lakes is generally associated with particulate organic and inorganic material rather than with dissolved organic matter (DOM). These authors concluded that natural water significantly reduces copper toxicity to aquatic organisms when compared with laboratory systems manipulated using synthetic chelators like EDTA.

Sunda (1987) proposed a basic mechanism for explaining the observed relationship between free ion activities and the bioavailability of metals such as copper. He observed that the complexed species of copper are charged or polar and cannot pass directly across the lipid bilayer of the cell membrane. Thus, transport across the membrane would require that complexed copper interact with specific metal transport proteins. Because the free ion activity is a measure of the potential reactivity of a metal, it reflects the ability of that metal to interact with these transport proteins.

Clements and others (1988) spiked freshwater mesocosms with 12 to 20 µg Cu/L and 15 to 27 µg Zn/L. These researchers found significantly reduced numbers of taxa, numbers of individuals, and abundance of most dominant taxa within 4 days. After 10 days, control streams were dominated by Ephemeroptera and tanytarsid chironomids, whereas treated streams were dominated by Hydropsychidae and Orthocladini. Responses of benthic communities to metals observed at Clinch River (Russel County, Virginia), a system impacted by copper and zinc, were similar to those in experimental streams. Copper levels on the Clinch River varied from not detectable at upstream controls to 105 µg/L at the point of discharge. Ephemeroptera and Tanytarsini, which constituted 48% to 46% of the macroinvertebrate community at upstream reference stations, were significantly reduced at all effluent sites. In this natural system, impacted stations were dominated by Hydropsychidae and Orthocladini. Interestingly, significant decreases in the number of all taxa and the abundance of individual species were observed at

downstream Station 6, where 9 ± 7 (one standard deviation) $\mu\text{g/L}$ Cu was observed. The researchers found that Trichoptera and Orthoclad chironomids were tolerant of high levels of copper. Hardness at these Clinch River (Virginia) stations averaged 169 ppm (CaCO_3) and alkalinity averaged 148 $\mu\text{g/L}$. At this hardness, the EPA chronic criterion is 17.8 $\mu\text{g/L}$. However, note that stations located directly downstream from the discharge had much higher copper levels (47 to 105 $\mu\text{g/L}$). Copper levels this high would likely have significant effects on the drift community. This is seen in a follow-up study (Clements and others 1992) in which data from 1986 through 1989 were examined upstream and downstream from the power plant following a decrease in the copper content of effluent from 480 $\mu\text{g/L}$ in 1987 to 260 $\mu\text{g/L}$ in 1989. Copper concentrations were reduced at downstream Station 8 from 127 $\mu\text{g/L}$ in 1987 to 52.2 $\mu\text{g/L}$ in 1989. The number of taxa increased from approximately 10 in 1987 to 20 in 1989. Only small decreases in both the number of taxa and the number of individuals per sample were observed in 1989, suggesting only minor effects at the observed copper concentration of 52.2 $\mu\text{g/L}$.

Gower and others (1994) examined the relationship between invertebrate communities and a variety of metals in southwest England. Their work suggests that copper, followed by aluminum, zinc, and cadmium, are the metals most responsible for influencing the observed changes in the invertebrate community. Clements and others (1988, 1992) found that Ephemeroptera and Tanytarsini were very intolerant of copper in the Clinch River, whereas Hydropsychidae and Orthocladid chironomids dominated impacted stations.

The results of Gower and others (1994) are summarized in Table II-2.

In this table, observed copper concentrations and hardness values were combined by dividing the observed copper concentration by the EPA chronic copper criterion at the documented level of hardness. These values should be interpreted as the numeric factors (or toxic units) by which observed copper exceeded the EPA chronic freshwater standard. Community information is displayed by sample for each taxonomic group. The number of individuals in each taxonomic group is followed by the mean number of species, per sample, in parentheses.

These data are presented in some detail because they clearly demonstrate the insensitivity of at least one flatworm species (Tricladida), some caddis flies (Trichoptera), and chironomids (particularly Orthoclaudiinae) to very high water column concentrations of copper (245 \times EPA standard). Oligochaetes, caseless caddis flies, and stone flies (Plecoptera) are relatively insensitive at copper concentrations up to 32 \times the EPA standard, but the population was essentially extirpated at the highest levels of 245 \times the EPA standard. It is certainly possible that caseless caddis flies and stone flies represent the drift community in this study and the period of exposure to elevated copper concentrations is unknown. This observation is supported by the reduced numbers of resident (cased) caddis flies observed in areas where the copper concentrations exceeded the EPA chronic copper standard by a factor of 5.3.

Table II-2—Contribution of selected major taxa to total macroinvertebrate fauna and number of species as function of copper water column levels

Taxonomic group	Contribution of taxon (%) and no. species (in parentheses) for proportional increase in EPA copper criterion at observed level of hardness ^a							
	2.0 \times		5.3 \times		31.6 \times		244.7 \times	
	4,598 <i>M</i>	(39 <i>S</i>)	989 <i>M</i>	(21.3 <i>S</i>)	2,219 <i>M</i>	(12.2 <i>S</i>)	2,378 <i>M</i>	(9.2 <i>S</i>)
Tricladida (flatworm)	7.7	(1.3)	3.4	(1.0)	15.0	(1.1)	30.2	(0.8)
Oligochaeta	16.2	(4.8)	6.8	(2.4)	20.9	(1.3)	0.7	(0.3)
Ephemeroptera	17.4	(3.1)	38.1	(2.0)	16.7	(0.6)	0.0	(0.0)
Plecoptera	19.3	(4.9)	8.5	(2.3)	7.2	(1.3)	1.1	(0.3)
Coleoptera	4.0	(2.4)	0.6	(0.8)	0.7	(0.4)	0.6	(0.6)
Trichoptera (cased)	4.8	(3.0)	12.4	(1.8)	0.1	(0.2)	0.1	(0.1)
Trichoptera (caseless)	4.8	(3.4)	14.7	(3.0)	5.4	(1.8)	4.8	(1.3)
Total EPT ^b	46.3	(14.4)	73.7	(9.1)	29.4	(3.9)	6.0	(1.7)
Chironomidae	16.9	(8.0)	11.3	(4.4)	31.1	(3.8)	60.3	(3.8)
Orthoclaudiinae	9.1	(4.7)	4.8	(1.8)	18.4	(2.1)	54.5	(2.4)

^aTotal macrovertebrates/sample (*M*) and contribution of taxon to macroinvertebrate fauna are mean values. *S* is number of species. Source: Gower and others (1994).

^bEPT refers to aggregate numbers of insects in Ephemeroptera, Plecoptera, and Trichoptera.

Interestingly, the order Ephemeroptera, frequently described as very susceptible to copper intoxication, represented nearly 40% of the macroinvertebrate community at 5.3× the EPA standard, and at least one species was able to tolerate 31.6× the EPA standard. In addition to describing general trends in copper susceptibility, these data suggest that some species in the sensitive orders Ephemeroptera, Plecoptera, and Trichoptera are able to tolerate very high levels of copper, suggesting that increasing information is provided by identification of infauna to the level of genus or species. On the other hand, it should be noted that total species richness (number of species) declines monotonically and is perhaps the best indicator of increasing copper toxicity in this study. While the numbers of Ephemeroptera, Plecoptera, and Trichoptera do not follow this monotonically decreasing trend, if these orders in the aggregate are considered, it is found that species richness is inversely correlated with copper concentrations.

Kiffney and Clements (1994) examined the effects of heavy metals on a macroinvertebrate assemblage from a Rocky Mountain stream in experimental microcosms and found significant reductions in a number of taxa at their “1×” treatment of 12 µg Cu/L. The authors stated that this value was approximately equal to the EPA freshwater chronic copper standard at the measured hardness of 38.3 mg/kg (CaCO₃). However, at that hardness, the EPA acute criterion is approximately half the tested concentration (6.9 µg/L compared with 12 µg/L) and the chronic EPA criterion is only 38% of the test concentration. The results of this study followed that of others reported here. Significant reductions were observed in the order Ephemeroptera, particularly in the family Heptageniidae. A large variation was observed in chironomid response to copper with significant reductions in the Tanytarsini and Tanytopodinae and a small reduction in the Orthocladiinae and Chironomini.

Rutherford and Mellow (1994) examined the effects of low pH and high dissolved metal (particularly copper) content on the fish and macroinvertebrates in beaver ponds located on an abandoned ore roast yard near Sudbury, Ontario, Canada. Table II-3 summarizes the physicochemical properties of the water at three sample stations. Hardness values were not provided in this study. At all test stations, dissolved copper exceeded background levels by factors of six (Station 1) to 200 (Station 3). Other metals were elevated but not to the very high levels associated with copper, and it appears reasonable to suggest that most of the effect seen in the macrobenthic community was associated with this metal.

Table II-4 summarizes the number of individuals within the most copper-sensitive and copper-tolerant species observed in the study by Rutherford and Mellow (1994). The data suggest that the genus *Chironomus* is very tolerant to even extraordinary levels of copper (600 µg/L). The Tanytopodinae are tolerant of moderate copper levels (45 µg/L) as are several species of dragonflies (order Odonata). In contrast,

Table II-3—Water chemistry at selected stations in Rutherford and Mellow (1994) study

Station	pH	Temperature (°C)	Dissolved oxygen (mg/L)	Copper (µg/L)
1 (upstream)	6.7	22.2	8.0	18
3 (roast yard)	3.7	22.2	8.1	600
4 (downstream)	6.2	23.3	7.6	45

Table II-4—Selected macroinvertebrate taxa with significant sensitivity or tolerance to high copper levels at sample stations in Rutherford and Mellow (1994) study^a

Taxon	Number of individuals at various sample stations (dissolved Cu concentration)		
	1 (18 µg/L)	3 (600 µg/L)	4 (45 µg/L)
Total number species	<u>40</u>	<u>1</u>	<u>25</u>
Total number macroinvertebrates	<u>228</u>	<u>105</u>	<u>145</u>
Chironomidae	10	0	14
Tanytopodinae			
<i>Chironomus</i>	13	105	23
<i>Cladopelma</i>	12	0	2
<i>Microtendipes</i>	<u>3</u>	<u>0</u>	<u>0</u>
<i>Polypedilum</i>	9	0	8
Diptera, <i>Chaoborus</i>	28	0	2
Himiptera, <i>Corisella</i>	7	0	3
Odonata, Corduliidae	13	0	4
<i>Leucorrhinia</i>	1	0	23
Coenagrionidae	0	0	44
Trichoptera, <i>Oecetis</i>	0	0	2
<i>Banksiola</i>	0	0	3
Amphipoda, <i>Hyalolella azteca</i>	<u>3</u>	<u>0</u>	<u>0</u>
Naididae	<u>37</u>	<u>0</u>	<u>0</u>
Mollusca, <i>Physa</i>	<u>8</u>	<u>0</u>	<u>0</u>
<i>Helisoma</i>	<u>29</u>	<u>0</u>	<u>0</u>
<i>Sphaerium</i>	<u>15</u>	<u>0</u>	<u>1</u>
Hirudinea	<u>5</u>	<u>0</u>	<u>0</u>

^aIndividuals exhibiting moderate to strong copper tolerance are underlined. Dissolved copper concentrations are provided in parentheses after each station number.

all the mollusks in this study were intolerant of copper at 45 µg/L, but survived concentrations six times that of the approximately 3-µg/L background level.

Macroinvertebrates were sampled with a D-frame net (1-mm mesh) in near-shore vegetation, detritus, and muck at the bottom of pools and in open water. The net was maneuvered for about 15 s in each of these habitats. Based on Brook's experience (unpublished data), the number of taxa at Stations 1 and 4 can be representative of beaver dam habitats.

However, the low abundance of all taxa suggests that these areas were not very productive. The intolerance of mollusks, arthropods, and some oligochaetes (Naididae) to copper is noteworthy. These data, like those of many other studies reviewed in this publication, suggest that copper tolerance varies widely among genera—even within the same family. These data also suggest that diverse (albeit suppressed) communities of macroinvertebrates can tolerate dissolved copper concentrations of at least 45 µg/L.

In summary, research has demonstrated trends in the relative sensitivity of freshwater macroinvertebrates to copper intoxication. However, Gower and others (1994) point out that at least some species within the sensitive EPT can tolerate very high levels of copper intoxication. Lastly, these data suggest that species richness for all fauna, or for the aggregated orders EPT, is better correlated with the degree of copper intoxication than is an analysis at some lower levels of taxonomic structure. Ammann and others (1997) provided an excellent review of the idea of taxonomic sufficiency for measures of impact in aquatic systems. They conclude that in at least the 23 studies they analyzed, identification and evaluation of infauna to the level of phylum were sufficient to document effects. In addition, this review apparently indicates that significant increases in dissolved copper above the EPA water quality acute or chronic criterion are required before community effects can be expected.

Regulatory Levels for Water Quality Criteria

The EPA has developed acute and chronic freshwater copper criteria as a standard against which to assess environmental

effects (U.S. EPA 1995). The preceding literature review suggests that these criteria are conservative from the point of view of the environment and that observable effects on communities of aquatic invertebrates are unlikely to be observed until these criteria are significantly exceeded. The EPA acute and chronic criteria are dependent on water hardness and are given in Equations (1) and (2) and summarized in Figure II-1.

$$\text{EPA acute copper criterion} \leq 0.960 \exp \{0.9422[\ln(\text{hardness})] 1.464\} \quad (1)$$

The acute copper criterion is a 1-h average concentration not to be exceeded more than once every 3 years on average.

$$\text{EPA chronic copper criterion} \leq 0.960 \exp \{0.8545[\ln(\text{hardness})] 1.465\} \quad (2)$$

The chronic copper criterion is a 4-day average concentration not to be exceeded more than once every 3 years on average.

Sedimented Copper and Aquatic Organisms

Cain and others (1992) compared copper concentrations in the insect orders Trichoptera and Plecoptera with concentrations in mine-waste-contaminated sediments on the Clark Fork River in Montana. They observed sediment concentrations of 779 µg/g in river reach 0 to 60 km; 408 µg/g in reach 107 to 164 km, and 129 µg/g in reach 192 to 381 km (distances are in kilometers downstream from Warm Springs Creek). These levels were significantly above the 18 µg/g observed at unaffected reference sites. The authors found significant variability in uptake between various taxonomic

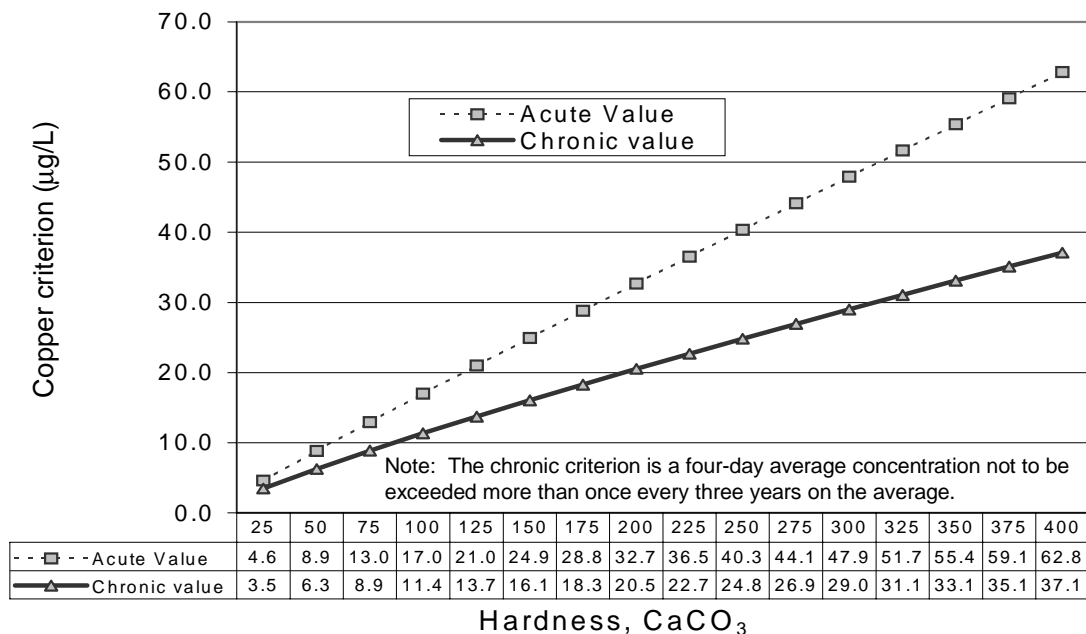

Figure II-1—EPA chronic and acute copper criteria for fresh water.

and functional groups. Detritivores held higher levels of copper than did omnivores or predators. This was especially true in the most contaminated reach (0 to 60 km). No appropriate analysis of the community structure was presented.

Diks and Allen (1983) examined the bioavailability of different forms of copper associated with sediments. In their study, the distribution of copper was determined by assessing different levels of sedimented copper (0, 2.5, 5.0, 7.5, and 10.0 mg Cu/kg) in five geochemical fractions of chemically extracted sediments and in tubificid worms. The authors used five chemical extraction protocols with a range of aggressiveness in liberating copper from the five geochemical compartments being considered. The least aggressive was 1.0 M MgCl₂, pH 7, with extraction at room temperature for 1 h. This procedure was considered appropriate for extracting only the absorbed/exchanged copper. The most aggressive procedure was 1.0 M NH₂O₂·HCl in 25% HOAc, with extraction at 96°C for 6 h. This procedure was considered sufficient to extract all copper, including moderately reducible forms incorporated into the crystalline structure of iron oxides.

Diks and Allen (1983) found that free ionic metals, as well as most metals ion exchanged onto fine-grained solids, were biologically available. Less available forms included metals contained in solid organic materials or precipitated and coprecipitated in metal oxide coatings. Metals incorporated into crystalline structures were not biologically available. Regression analysis was used to evaluate the effects of the extraction technique and metal levels in each geochemical compartment on copper uptake by the tubificid worms. The authors found that only the copper extracted from the manganese oxide/easily reducible phase was significantly correlated ($\alpha = 0.05$) with copper uptake. They suggested that the redox potential and pH in the gut of the worm was such that manganese oxide coatings were dissolved during digestion, making the copper available for uptake. This study suggested that the 0.1 M NH₂OH·HCl + 0.01 M HNO₃, pH = 2 extraction, conducted at room temperature for 30 min (Chao 1972, quoted in Diks and Allen 1983) is most appropriate for determining biologically available copper in sediments. This is important because in the four sediments tested at 10 mg Cu/L (Des Plaines, Calumet, Flatfoot, and Wabash Rivers), the proportion of copper biologically available in the amended sediments averaged 72%. The remaining 28% was found in geochemical phases that were apparently not biologically available. Even more striking was the distribution of copper in the natural (unamended) sediments. In these natural sediments, only 35% of the total copper burden appeared to be biologically available while 65% was incorporated in biologically unavailable geochemical phases.

The purpose of this discussion is to suggest that extraction techniques and the biological availability of copper in sediments are important parameters for determining sediment standards against which to assess biological risks. Based on

this work, a mildly aggressive extraction technique, such as that described in Chao (1972), is recommended. More aggressive extraction techniques used for assessing background copper may result in assuming a higher than appropriate existing level of biologically available copper, leading to an overly conservative assessment, whereas less aggressive extraction techniques may result in assessments that are insufficiently protective of biological resources.

Flemming and Trevors (1988) dosed a calcareous, southern Ontario stream sediment with up to 10,000 µg copper sulfate/gram dry sediment and examined the uptake of copper and microbial responses. They found that sediment uptake of copper was nearly 100% for doses up to 2,800 µg Cu/g. At higher levels of copper, the sediment uptake capacity was diminished, and at 10,000 µg Cu/g sediment, only approximately 60% of the copper was removed from the water column. Aerobic heterotrophic bacteria were unaffected at the end of 2 months in sediments amended with as much as 1,000 µg Cu/g sediment. Bacterial colony counts actually increased at higher copper levels, which the authors attributed to the development of a population of copper-tolerant microorganisms. The bacterial community from the high copper amended sediments displayed a 500-fold increase in copper tolerance compared with bacteria from control sediments when plated on nutrient agar amended with excess copper. The authors suggest that 87.5% of the copper added in these studies was transformed from the toxic Cu⁺² form to carbonate complexes, 12% was complexed with dissolved organic matter, and that only 0.5% was available as potentially toxic copper hydroxide complexes or as the toxic Cu⁺² free ion. The point is that calcareous sediments can significantly reduce the toxicity of very high concentrations of cupric ions. At least that statement appears true for the microbial community.

Munkittrick Dixon (1989) examined the response of aquatic invertebrates to a gradient of copper and zinc contamination associated with mining activities along the Manitowadge chain of lakes in northern Ontario. Their data are summarized in Table II-5. The sediment at Station 3 (22.7 ± 6.4 mg Cu/kg) in unaffected Loken Lake (LOK) was not significantly different from the sediment at Station 3 (25 ± 8 mg Cu/kg) in impacted Manitowadge Lake (MAN). However, the water column copper concentration at unaffected LOK was only 1.7 µg/L compared with 9.8 µg/L at significantly impacted MAN. Station 1 at MAN had the highest level of sediment copper (160 mg/kg) of the three stations in that lake. This station also had the highest abundance (12,838 invertebrates/m²), the highest diversity (21 species/sample), and the highest number of typically sensitive cladocerans when compared with the other two stations in this lake, each of which had lower levels of sedimented copper. Munkittrick and others (1989) also presented detailed enumeration of the chironomid species in each lake. Interestingly, for nearly all genera of chironomids, the sample station with the highest

Table II-5—Copper concentrations in water column and sediments of control Loken Lake (LOK) and impacted Manitowadge Lake (MAN)^a

Endpoint	Copper (mg/kg) at control and impacted lakes (Station no.)					
	LOK (1)	LOK (2)	LOK (3)	MAN (1)	MAN (2)	MAN (3)
Sediment copper	7.5	4.0	22.7	160.0	123.0	25.0
Water copper	0.0032	0.0013	0.0017	0.0098	0.0095	0.0098
Cladocera	1,484	1,746	5,326	437	175	87
Copepoda	172,023	1,383	4,366	1,834	1,048	262
Chironomids (total)	11,701	20,585	13,598	9,868	5,502	4,017
<i>Procladius</i>	1,659	1,878	4,803	1,834	2,358	873
<i>Cryptotendipes</i>	262	74	0	1,048	0	87
<i>Pagastiella</i>	175	144	87	4,629	3,057	1,310
<i>Polypedilium</i>	5,852	4,544	1,572	0	0	0
<i>Cladotanytarsus</i>	873	6,113	1,921	1,397	0	175
<i>Tanytarsus</i>	1,659	5,458	2,620	262	0	175
Total abundance	47,069	36,083	25,737	12,838	8,035	5,240
Diversity	36	35	28	21	8	17

^aSignificant macroinvertebrate data included to indicate faunal response. Data from Munkittrick and others (1991).

levels of sedimented copper in MAN also had the highest number of chironomid species. The copper-intolerant chironomid genera *Polypedilium*, *Cladotanytarsus*, and *Tanytarsus*, were abundant in the control lake (LOK) but were present only at Station 3 (the station with the highest sediment concentration of copper) in affected MAN.

In contrast, under conditions of the reported low water column copper concentrations in LOK, there is an apparent decrease in the number of sensitive amphipods, gastropods, and oligochaetes at the station with the highest sedimented copper concentration (Station 3, 22.7 mg Cu/kg sediment). This pattern was also observed in the more detailed chironomid taxonomy where Station 3 typically held as many or more chironomids of all genera than did the other stations with lower levels of sedimented copper. This is only generally true because *Polypedilium simulans* was observed in much lower abundance at Station 3 than at the other reference stations.

These observations suggest that the primary invertebrate response in these lakes was associated with elevated water column concentrations of copper and not to the sedimented levels, which spanned a wide range of values. This is likely because the sedimented copper was not biologically available. The point is that the elevated water column concentrations of copper in affected MAN appear to be masking any effect associated with sedimented copper up to the observed level of 160 µg Cu/kg dry sediment weight.

Miller and Dixon (1992) further examined the Manitowadge chain of lakes. They reported average water column concentrations of 15 µg/L in MAN at a hardness of 110 ppm

CaCO₃. This exceeded the EPA copper criterion for fresh water (12.31) by a factor of 1.2. Sedimented copper in MAN averaged 93 mg Cu/kg sediment. No significant difference was observed in the standard length, weight, age, or condition factor of white suckers between MAN and LOK. Copper levels in invertebrates (tissue levels) were significantly correlated (Spearman's correlation at $p \leq 0.01$) with dissolved concentrations of copper, but not with sediment copper concentrations over a wide range of values.

Kraft and Sypniewski (1981) examined the effects of high sedimented copper on the macroinvertebrate community of the Keweenaw Waterway. They found high concentrations of copper (approximately 589 mg Cu/kg dry sediment) in areas where the sediment consisted of about 66% silt and clay and much lower copper levels (approximately 33 mg Cu/kg dry sediment) in areas where the silt-clay content averaged 27% of the sediment grain size matrix. The authors observed significant differences in community structure with *Hexagenia*, *Tanytarsus*, *Peloscolex*, *Sphaerium* (mollusk), and *Pontoporeia* (arthropod) virtually excluded from the area with the high copper content. In contrast, the area with high sedimented copper held more individuals in the genera *Chironomus*, *Atribelos*, *Limnodrilus*, *Ceratopogonidae*, and *Dicrotendipes*.

Moore and others (1979) compared sediment concentrations of arsenic, mercury, copper, lead, and zinc with infauna in a series of lakes downstream from the Con Mine in the Canadian subarctic. In general, all the metals were significantly elevated in the upstream water column and sediments, complicating the analysis. Observed metal and infauna data are summarized in Table II-6. The sediments and water column

Table II-6—Metal levels and infauna at lakes downstream from Con Mine in Canadian subarctic

Endpoint	Metal concentration (mg/kg dry sediment weight)							
	Meg Lake		Keg Lake		Peg Lake		Great Slave Lake	
	Sediment	Water	Sediment	Water	Sediment	Water	Sediment	Water
Arsenic	539	2.000	349	1.900	76	0.700	12	0.020
Mercury	132		47		80		53	
Copper	477	0.200	544	0.050	106	<0.020	82	<0.020
Lead	11	0.100	8	0.100	8	<0.020	14	0.008
Total number species		9		13		14		44
Number insect species		5		7		8		25
Number mollusk species		4		6		5		10
Total infaunal abundance		800		1,300		5,500		3,100

in Meg Lake were significantly impaired by each metal investigated. The most common species was the bivalve *Pisidium casertanum*, which is apparently very tolerant to metal intoxication. Seven chironomid and six mollusk species were observed in Keg Lake under the influence of very high metal content in sediments and the water column. Chironomids represented up to a maximum of 60% by numbers in the benthos, with *Procladius culiciformis* and *Psectrocladius barbimanus* dominating. Unlike in Meg Lake, *Pisidium casertanum* was rare in Keg Lake, with *Physa jennessi*, *Valvata sincera*, and *Lymnaea elodes* dominating at various times of the year. Metal levels between Meg and Keg Lakes were similar and it must be assumed that other environmental parameters were responsible for the shift in the mollusk community. Metal levels dropped significantly in Peg Lake, where a total of 14 species were found (8 chironomids, 5 mollusks, and 1 amphipod). Infaunal abundance increased significantly to 5,500/m² in Peg Lake—likely in response to the reduced metal concentrations. Further reductions were observed in Great Slave Lake. Sedimented copper levels were only approximately 15% and arsenic was only 3% of the maximum found in Keg Lake. Baseline infauna and metals were not evaluated at a remote (control) site in Great Slave Lake, and it was not possible to determine whether conditions reported in this paper are representative of background. However, 44 species in these samples had a mean abundance of about 3,100 infauna/m². Considering the high latitude at which this study was conducted, these numbers are similar to those observed at non-impacted reference areas by the author (Brooks, unpublished data). These data suggest that reasonably abundant and diverse infauna can be associated with copper levels as high as 82 µg Cu/g (dry sediment).

Puckett and others (1993) showed that metals, including copper, are associated with the silt-clay fraction of sediments and that wetlands appear to be important repositories for metals adsorbed to these fine-grained sediments. These findings support the conclusion that copper adsorbs to silt and clay rather than to the more coarse fractions of the sediment.

Rehfeldt and Sochtig (1996) observed high metal tolerance in *Baetis rhodani*. The larvae of this species are scrapers, picking up diatoms from the surface of stones. Depending upon the developmental stage and the availability of food, *B. rhodani* can also feed on detritus. This species is polyvoltine, occurring in different larval stages in rivers at all times of the year. Sediments in rivers studied by Rehfeldt and Sochtig (1996) contained between 30.7 and 2,917.4 mg Cu/kg dry sediment. *Baetis rhodani* contained between 64.0 and 226.2 mg Cu/kg dry tissue weight. Copper content in the larvae was highly correlated with sediment copper concentrations (Spearman rank correlation coefficient = 0.94, $p < 0.01$). Table II-7 describes the sediment bioconcentration factor for this species.

Water in these rivers was described as “soft” with neutral pH (7.1 to 8.5). The sediments were dried, ground to a powder, and sieved to a particle size <2 mm. Metals were extracted by boiling in 100 mL nitrohydrochloric acid for an unspecified time. This aggressive extractive technique may have liberated copper from other than biologically available geochemical partitions, as previously discussed. This would help explain the wide variability in sediment BCF (0.06 to 2.08) documented in Table II-7 for a single species. Alternatively, some copper regulation may have occurred because the copper concentration in *B. rhodani* is fairly constant, varying only by a factor of 3.5, with the lowest tissue burdens associated with the lowest sediment concentrations. It is also interesting to note that dissolved copper concentrations in the Oker River were very high (132.9 ± 53 µg/L (mean and 95% confidence interval)), further suggesting that *B. rhodani* can regulate copper uptake.

Significant differences were observed in the macrobenthic communities associated with polluted and unpolluted rivers by Rehfeldt and Sochtig (1996). These authors found that gammarid amphipods were particularly intolerant of copper and that mayflies of the genus *Baetis* were highly tolerant to copper. Other species in the EPT (Ephemeroptera, Plecoptera, and Trichoptera) group were found in both polluted and

Table II-7—Heavy metal contents of sediments and *Baetis rhodani* larvae collected from rivers in German Federal Republic^{a,b}

River	Sediment Cu (mg/kg)	<i>B. rhodani</i> Cu (mg/kg)	Sediment bioconcentration factor
Oker (Probsteib River)	2917.4	169.2	0.06
Oker (Schladen River)	438.8	226.2	0.52
Ecker	30.7	64.0	2.08
Grane	365.7	168.2	0.46
Laute	155.5	126.5	0.81
Tolle	90.7	110.2	1.21

^aCu values per dry sediment.

^bData from Rehfeldt and Sochtig (1996).

Table II-8—Sediment types, test conditions, and results of copper-spiked sediment bioassays^a

Sediment	TOC (%)	Silt-clay (%)	Sediment 10-day LC ₅₀ (µg/g)			
			<i>C. tetans</i>	<i>D. magna</i> ^b	<i>G. lacustris</i>	<i>H. azteca</i>
Tualatin River	1.8	59.3	2,296	937	—	—
Soap Creek Pond	3.0	84.8	857	681	964	1,078

^aData from Cairns and others (1984).

^bBioassays based on 48-h LC₅₀.

unpolluted streams, but numbers were generally reduced in polluted areas. Chironomids were found in reduced numbers in polluted streams. This suggests that tolerant chironomid species are probably not present in these watersheds.

Cairns and others (1984) spiked control sediments from the Tualatin River and Soap Creek Pond with varying levels of copper to achieve sedimented copper levels varying between 59 and 10,600 mg/kg. Overlying water in these experiments was continually renewed until the sediments and water came into equilibrium. The authors then conducted sediment bioassays using sensitive species of arthropods (*Chironomus tetans*, *Daphnia magna*, *Gammarus lacustris*, and *Hyaella azteca*). Test conditions and results are summarized in Table II-8.

There was little or no difference between control survival and survival of any species in copper-spiked sediments at concentrations of 488 to 618 mg Cu/kg dry sediment in Soap Creek Pond. Nine of 10 *Chironomus tetans* arthropods survived for 10 days in sediment copper concentrations of 1,080 mg/kg; 4 survived at concentrations to 3,950 mg/kg. Control and treatment survival of *D. magna* was equal (9/10) at sediment concentrations to 400 mg Cu/kg dry sediment. This experiment suggests that copper is not bioavailable in sediment that is rich in organic carbon and contains a high percentage of fines (silt and clay). This study also suggests that copper levels less than perhaps 600 mg/kg have little biological consequence in these “robust” sediments.

Summary of Sedimented Copper Toxicity

The bioavailability of sedimented copper appears dependent on sediment physicochemical characteristics, including the proportion of fines (silt and clay), overlying and interstitial water pH, hardness, dissolved oxygen, and the presence of sedimented organic carbon. Background levels of copper reviewed in the assessment varied (Table II-9).

These data suggest that sedimented copper concentrations in unpolluted reference areas can vary from 2.0 to at least 80 mg Cu/kg dry sediment. Diks and Allen (1983) suggest that moderately aggressive copper extraction protocols, such as that of Chao (1972) are appropriate for determining the bioavailable copper in sediments. More aggressive protocols using hot acid extraction techniques over extended periods will overestimate the amount of bioavailable copper by liberating copper from the lattice structure of other minerals.

Given that copper delivered to the sediments from the overlying water column and that water column and sediment concentrations are generally positively correlated, the copper concentration in the overlying water column apparently has the most influence on aquatic fauna and flora. Copper does bioconcentrate, and Cain and others (1992) present data suggesting that infauna, particularly detritivores, can bioaccumulate copper from sediments; copper does not appear to biomagnify through food webs.

This review suggests that aquatic invertebrates vary significantly in their response to sedimented copper. For instance,

Table II-9—Background freshwater sediment copper levels

Source	Geographic location	Copper (mg/g dry sediment)
Siipola (1991)	Lower Columbia River	18.0 to 66.0
Tetra Tech (1994)	Lower Columbia River	19.3 to 49.9
Munkittrick and Dixon (1989)	Loken Lake, northern Ontario	22.7 + 6.4 (< 35.2)
Munkittrick and others (1991)	Northern Ontario	4.0 to 23.0
Cairns and others (1984)	Tualatin River, Oregon	59.0
Cairns and others (1984)	Soap Creek Pond, University of Oregon	210.0
Cain and others (1992)	Clark Fork River, Montana	18.0
Moore and others (1979)	Great Slave Lake	82.0
Schmidt (1978)	Unpolluted sediments from near-shore areas	2.0 to 78.0

of the seven genera of midges described in the studies referenced here, five genera are tolerant of sedimented copper to levels exceeding 100 mg Cu/kg dry sediment. Only the genera *Tanytarsus* and *Polypedilium* appear intolerant of sedimented copper at levels of 123 to 160 mg/kg. Note that the copper concentration in the study of Munkittrick and others (1991) was 9.5 to 9.8 µg Cu/L. Water hardness was not provided in this report and it is not possible to assess whether the response of these species was to copper in the water or in sediments. Based on this review, it appears that only *Tanytarsus*, *Polypedilium*, *Hexagenia*, *Sphaerium*, and *Pontoporeia* are potentially intolerant of sedimented copper. On the basis of this review, it was not possible to determine whether the susceptibility of these species was to sedimented copper or copper carried in the water column. Confirmation of the susceptibility of these taxa to sedimented copper would require sediment bioassays, such as that performed by Cairns and others (1984). This review, which is summarized in Table II-10, indicates that many species are tolerant to high levels of sedimented copper. Levels that are much higher than the background values presented in Table II-9.

Benchmarks for Copper in Marine and Freshwater Sediments

The State of Washington has developed marine sediment quality standards for metals (WAC 173-204-320). These standards are based on apparent effects thresholds (AETs). Different jurisdictions may develop more or less stringent standards depending on a number of factors.

Standards for freshwater sediments were not available from any jurisdiction. Jones and others (1997) summarized available toxicological benchmarks for screening contaminants of potential concern for effects on sediment-associated biota. The U.S. Department of Energy accomplished this work in an effort to identify benchmark levels of contaminants that warrant further assessment or are at a level that requires no further attention at hazardous waste sites. It should be

emphasized that these benchmarks were not developed or intended as sediment quality criteria for surface waters:

Sediment benchmarks must not be used as the sole measure of sediment toxicity. Field studies and toxicity tests shall be the primary indicators of toxicity of sediments; benchmarks may be used to determine which chemicals present in the sediment are most likely causing the toxicity. (Jones and others 1997).

SLC Approach

The screening level concentration (SLC) approach estimates the highest concentration of a particular contaminant in sediment that can be tolerated by ~95% of benthic infauna. The SLC is derived from synoptic data on sediment chemical concentrations and benthic invertebrate distributions. First, the species SLC is calculated by plotting the frequency distribution of the contaminant concentrations over all sites (at least 10) where the species is present. The 90th percentile of this distribution is taken as the SLC for that species. Next, a large number of species SLCs are plotted as a frequency distribution to determine the contaminant concentration above which 95% of the species SLCs occur. This final concentration is the SLC.

Dr. Gaudat noted that the Ontario guidelines were developed without reference to water or sediment pH, total organic carbon, sediment grain size, or any other environmental parameter affecting the fate, transport, deposition, and bioavailability of the compounds under consideration (Connie Gaudat, Soil and Sediment Section, Guidelines Division, Environment Canada, personal communication, 1995). In discussing copper, for instance, Gaudat stated that documentation of worst cases involving metals may have occurred in soft water with very low pH values and coarse sediments. This may be especially true in Ontario, where the guidelines were developed, because it lies on the continental shield characterized by low soil buffering capacity and low pH. Gaudat noted that many pristine areas in Canada have

Table II–10—Tolerance of various freshwater taxa to sedimented copper reported in literature review

Taxon	Relative tolerance	Source ^a	Sediment copper (µg/kg dry sediment)
Cladocera			
<i>Daphnia magna</i>	Tolerant	5	681 to 937
Chironomids			
<i>Chironomus</i>	Tolerant	2,5	589 to 2296
<i>Procladius culciformis</i>	Moderately tolerant	3	477 to 544
<i>Psectrocladius barbimanus</i>	Moderately tolerant	3	477 to 544
<i>Dicrotendipes</i>	Tolerant	2	589
<i>Pagastiella</i>	Tolerant	1	123 to 160
<i>Polypedilium</i>	Intolerant	1	123 to 160
<i>Tanytarsus</i>	Intolerant	1, 2, 6	123 to 589
Ephemeroptera			
<i>Hexagenia</i>	Intolerant	2	589
<i>Baetis rhodani</i>	Tolerant	4	<2,917
Diptera			
<i>Ceratopogonidae</i>	Moderately tolerant	2	589
Molluska			
<i>Sphaerium</i>	Intolerant	2	589
<i>Pisidium casertanum</i>	Tolerant	3	477 to 544
<i>Physa jennessi</i>	Tolerant	3	477 to 544
	Intolerant	6	
<i>Valvata sincera</i>	Tolerant	3	477 to 544
<i>Lymnaea elodes</i>	Tolerant	3	477 to 544
Amphipoda			
<i>Pontoporeia</i>	Intolerant	2	589
<i>Gammarus lacustris</i>	Tolerant	5	964
<i>Hyalella azteca</i>	Tolerant	5	1,078
Oligochaeta			
<i>Limnodrilus</i>	Tolerant	2	589
Taxa richness	Intolerant	6	—
Total abundance	Moderately tolerant	6	—

^a(1) Munkittrick and others 1991, (2) Kraft and Sypniewski 1981, (3) Moore and others 1979, (4) Rehfeldt and Sochtig 1996, (5) Cairns and others 1984, (6) Rutherford and Mellow 1994.

background levels that exceed the Ontario guidelines. Environment Canada is developing sediment standards, but until those standards are developed, Environment Canada and the Ontario Ministry of Environment use site-specific risk assessments to determine appropriate sediment quality criteria. The site-specific standards are always greater than Ontario's guidelines because the worst-case conditions associated with the guidelines are seldom, if ever, encountered. Note that Jones and others (1997) do not recommend the SLC method, even for developing benchmarks against which to assess the potential biological effects of contaminants at hazardous waste sites.

AET Approach, Marine Sediments

The AET approach uses data from matched sediment chemistry and biological effects measurements. Biological effects

can be assessed by either benthic community surveys or sediment toxicity tests. An AET concentration is the sediment concentration of a selected chemical above which statistically significant biological effects always occur. Jones and others (1997) defended the use of estuarine benchmarks for evaluating freshwater sites when freshwater benchmarks are not available. The Washington State AET for copper in marine environments is 390 µg/g dry sediment.

NOAA Approach, Marine and Estuarine Sediments

The National Oceanic and Atmospheric Administration (NOAA) annually collects and chemically analyzes sediment samples from sites located in coastal marine and estuarine environments throughout the United States. These data were used to evaluate three basic approaches to establishing effects-based criteria: the equilibrium partitioning approach

(applicable to non-ionic organic compounds), the spiked-sediment toxicity test approach, and various methods of evaluating synoptically collected biological and chemical data in field surveys (Long and Morgan 1991). Chemical concentrations observed or predicted by these methods to be associated with biological effects were ranked, and the lower 10th percentile [effects range–low (ER–L)] and median [effects range–median (ER–M)] concentrations identified. The ER–L and ER–M values were recalculated by Long and others (1995) after omitting the few freshwater data included in the Long and Morgan (1991) calculation and after adding more recent data.

Jones and others (1997) noted that the NOAA values may be used to help identify sites with the potential to cause adverse biological effects. They caution that these are not NOAA criteria or standards and are not intended for use in regulatory decisions or other similar applications. The NOAA ER–L for copper is 34 mg Cu/kg dry sediment and the ER–M is 270 mg Cu/kg dry sediment.

FDEP Approach, Freshwater Sediments

The Florida Department of Environmental Protection (FDEP) methodology is similar to the NOAA approach. The updated and revised data set used by Long and others (1995) was also used by MacDonald (1994) to calculate threshold effects levels (TELs) and probable effects levels (PELs). Unlike the ER–L and ER–M, the TEL and PEL also incorporate chemical concentrations observed or predicted to be associated with no adverse biological effects (no-effects data). The TEL is the geometric mean of the 15th percentile in the effects data set and the 50th percentile in the no-effects data set. The PEL is the geometric mean of the 50th percentile in the effects data set and the 85th percentile in the no-effects data set. The TEL represents the upper limit of the range of sediment contaminant concentrations dominated by no-effects data. The PEL represents the lower limit of the range of contaminant concentrations that are usually or always associated with adverse biological effects (MacDonald 1994). The FDEP TEL is 18.7 µg Cu/g dry sediment weight and the PEL is 108 µg Cu/g dry sediment weight.

ARCS Project for Freshwater Sediments

The National Biological Service produced a set of freshwater sediment benchmarks for the EPA Great Lakes National Program Office. The threshold effects concentration (TEC) is intended to be a conservative screening value below which adverse effects are rarely observed. The no-effect concentration (NEC) is a representative high value intended to decrease the percentage of false positives, but to increase the percentage of false negatives when compared to TEC.

Recommended Interim Benchmarks for Copper

Jones and others (1997) recommended the use of a suite of benchmarks in evaluating the potential adverse effects

associated with a chemical on a site-specific basis. However elegant that approach may be, the usual permitting of projects using treated wood, particularly personal-use piers and floats, ferry terminals, and similar items, does not warrant development of a project-specific sediment quality standard. Recognizing that both the EPA and Environment Canada have cautioned that the screening benchmarks are not appropriate as sediment quality standards, the values in Table II–11 are provided as background.

The preceding discussion on the bioavailability and toxicity of copper suggests that sedimented total organic carbon, percentage of silt–clay fines, pH, dissolved oxygen, water hardness, and alkalinity can all affect the bioavailability and toxicity of sedimented copper. It would be preferable to rely on well-conceived freshwater sediment quality standards. Unfortunately, those standards have not been developed. The only regulatory level is the Washington State AET for copper in marine sediments: 390 µg/g. The literature review suggests that this level is too high to protect freshwater benthic organisms.

Until appropriate freshwater sediment quality standards are developed, the benchmarks given in Table II–12 are proposed for evaluating the benthic effects associated with copper lost from preserved wood. These levels are consistent with the range at which threshold effects are reported by Jones and others (1997) and at which sediment effects were reported in the reviewed literature. In addition, they appear consistent with background levels of copper found in many parts of North America and should avoid the curious penchant of some jurisdictions to invoke metal concentration criteria that are well below apparently unpolluted ambient levels. Loehr (1997) reported that several States have surface water quality arsenic standards in the range of 1.4 to 0.002 µg/L. He noted that the average concentration of arsenic in five brands of bottled water is 4.2 µg/L or 2,100× the lowest of these standards. Loehr further notes that surface water in Washington State contains 0.1 to 1 µg/L and that ocean water holds about 1.7 µg/L. The U.S. Department of Agriculture (USDA 1980) reported that Washington well-water contains between 5.0 and 6.0 µg/L arsenic and Oregon well-water as much as 1,700 µg/L. According to Loehr, it would be illegal to pour any of the tested bottled drinking water into any surface water.

The values in Table II–12 are higher than the no observed effects level (NOEL) and/or TEL values described in Table II–13 but lower than the PEL. It should be emphasized that all the values in Table II–13 are based on worst cases and do not take into consideration environmental factors that mediate environmental toxicity. For instance, the Ontario screening criterion for sedimented copper (16 µg/L) is based on the worst cases in the Ontario database, an area lying on the continental shield in which worst cases likely involve very low pH, low alkalinity and hardness, and coarse (rocky)

Table II-11—Jurisdictional copper sediment screening benchmarks for hazardous waste site contaminants

Jurisdiction	Criteria (Cu/g, dry sediment)	
Washington State Marine Sediment Quality Criteria	390	
National Oceanographic and Atmospheric Administration	ER-L 34	ER-M 270
Florida Department of Environmental Protection	TEL 18.7	PEL 110
Ontario Ministry of Environment Screening Levels	Low SLC (16)	Severe SLC (110)
Assessment and Remediation of Contaminated Sediments	TEC 28	NEC 54.8

Table II-12—Recommended benchmarks for assessing environmental risks associated with sedimented copper lost from pressure-treated wood

Sediment and water column characteristics	Acceptable levels of sedimented copper
Coarse-grained sediment (silt and clay) < 10% Total organic carbon < 0.2% Moderate to low pH (5.5 to 6.5) Low hardness and alkalinity (15 to 25 ppm CaCO ₃)	30 µg Cu/g dry sediment
Intermediate sediments (silt & clay between 10% and 25%) Total organic carbon between 0.2% and 1.0% Neutral pH (6.5 to 7.5) Moderate hardness and alkalinity (35 to 100 ppm CaCO ₃)	55 µg Cu/g dry sediment
Low energy, well-buffered streams and lakes (fines > 25%) Total organic carbon > 1.00% Greater than neutral pH (>7.5) High hardness and alkalinity (>100 ppm CaCO ₃)	100 µg Cu/g dry sediment

Table II-13—Sampling schedule, 1996–1997

Study day	Date	Activity
-29*	May 9, 1996	Baseline sampling (prior to any major disturbance) ^a
0	June 7, 1996	Construction completed on ACZA and ACQ-B structures
+13	June 20, 1996	Construction completed on CCA-C structure
+15*	June 22, 1996	Near-term effects monitoring ^b
+162*	November 16, 1996 ^c	Intermediate-term effects monitoring
+336*	May 9, 1997	Long-term effects monitoring ^d

*Days on which samples were collected.

^aBaseline sampling was completed approximately 2 days before construction of treatment spurs to provide minimum period between baseline and first post-construction sampling.

^bMetal losses from treated wood are highest on the day of immersion and decline exponentially with time (Brooks 1995, 1997a,b). Post-construction, near-term monitoring was accomplished as quickly after construction as possible to observe maximum water column concentrations of metals and their effect on aquatic invertebrates.

^cFall date was chosen to ensure a maximum amount of time for metal accumulation in sediments before anticipated winter storms could dilute and redistribute the metal downstream.

^dFinal monitoring period was chosen to coincide with baseline monitoring season and should represent long-term effects associated with the boardwalk in the Wildwood wetland.

substrates. As previously discussed, Environment Canada does not recognize these values as standards and cautions that background levels in other parts of Canada consistently exceed this screening value with no evidence of toxic effects. The benchmarks provided in Table II-12 are consistent with the range of TELs (28.5 to 96 µg Cu/g dry sediment) presented by Jones and others (1997).

Some insight regarding the appropriateness of adopting the copper screening values in Table II-11 as regulatory standards can be obtained by comparing similar data for the water column with the EPA freshwater regulatory standard for copper, adopted by many jurisdictions throughout the world. Suter and Tsao (1996) presented conventional benchmarks for priority contaminants in fresh water: 18 µg/L for acute copper and 12 µg/L for chronic copper, at 100 mg/L hardness. The EPA chronic value for copper was then compared with the lowest chronic values in the literature for various organisms: fish, 3.8 µg Cu/L; daphnids, 0.23; non-daphnids, 6.066; aquatic plants and invertebrates, 1.0; and all organisms, 0.23.

All of the lowest chronic values are lower than the EPA chronic copper criteria at 100 mg/L hardness. The literature clearly indicates that these chronic values were likely obtained under conditions of low alkalinity, low total hardness, low levels of organic carbon (dissolved and particulate), low levels of particulate inorganic carbon, or low pH. These conditions are unrepresentative of most natural bodies of water and therefore adoption of the lowest chronic values as a standard would be unnecessarily restrictive. The lowest-daphnid value (0.23 µg Cu/L) is less than ambient copper levels in most natural bodies of water.

It is unfortunate that regulatory standards have not been developed for sedimented copper in fresh water. The eventual development of appropriate standards by the EPA will take into account the environmental factors that affect sedimented copper toxicity and will provide reasonable estimates of sedimented copper that will not adversely affect biological resources.

Background of Wildwood Boardwalk Study

In 1995, the Bureau of Land Management and the USDA Forest Service proposed construction of an extensive boardwalk system designed to provide wheelchair access to the Wildwood Wetland Recreational Area on the western slope of Mount Hood in Oregon. The Wildwood area is described in Figure II-2.

Treated wood was the material of choice because of its low cost, strength, low weight, and natural appearance. In addition, this project provided the USDA Forest Service with an opportunity to assess the potential impacts of treated wood on biological resources in sensitive wetland areas. The study

design chosen for this evaluation was a before+after treatment-control (BATC) design that included measurement of water column, soil, and sediment levels of the metals of concern and an evaluation of the biological response to the treated wood structures. The Forest Products Laboratory of the Forest Service contracted with Aquatic Environmental Sciences to complete the biological assessment associated with this project.

It should be emphasized that the models of Brooks (1995, 1997a-c, 1998) do not make predictions for metal loss rates from overhead structures for either ACQ-B or ACZA. In these cases, most treated wood was not immersed in the water but located in the above-water boardwalk. For that reason, no attempt was made to model soil, sediment, or water column concentrations of preservative metals in the work reported here.

Water levels, temperature, and particulate organic matter vary seasonally in wetlands, and have a significant effect on invertebrate communities inhabiting these areas. Brooks (1995, 1997a-c, 1998) described the loss of metals and DDAC from immersed treated wood. For all preservatives, the highest metal losses occurred immediately after immersion and then declined exponentially to low levels within a few days to a month, depending on the preservative. Brooks (1995, 1997a-c, 1998) described metal accumulation in sediments associated with the use of ACZA-, ACQ-, and CCA-C-treated wood immersed in water. That analysis suggests that in the case of absent bedload movement associated with high current speeds, sediment copper, chrome, arsenic, and zinc concentrations associated with preserved wood should approach maximum values within 6 months after immersion. In consideration of these dynamics, the Wildwood wetland study was scheduled to begin in Spring 1996 with baseline sampling followed by post-construction sampling at +15 days, +162 days, and +336 days. The +15 day sampling was scheduled to evaluate the biological response to maximum concentrations of metal in the water column immediately after construction. The +162 day sampling occurred in the Fall before high water could possibly transport sedimented metals away from the structures, and the last sampling event (day +336) was designed to occur during the same season as the baseline and was used to evaluate the long-term effects of the boardwalk.

Materials and Methods

The underlying hypothesis of the Wildwood wetland study was that there would be no statistically significant changes in the benthic and epibenthic invertebrate community associated with the construction of wetland boardwalks using ACQ-B-, ACZA-, or CCA-C-treated wood or an untreated control. The Wildwood aquatic environment, with its very slow current speeds, fine-grained sediments, slightly acidic pH, low hardness, alkalinity, and dissolved organic carbon (DOC), represents a worst case. This hypothesis was

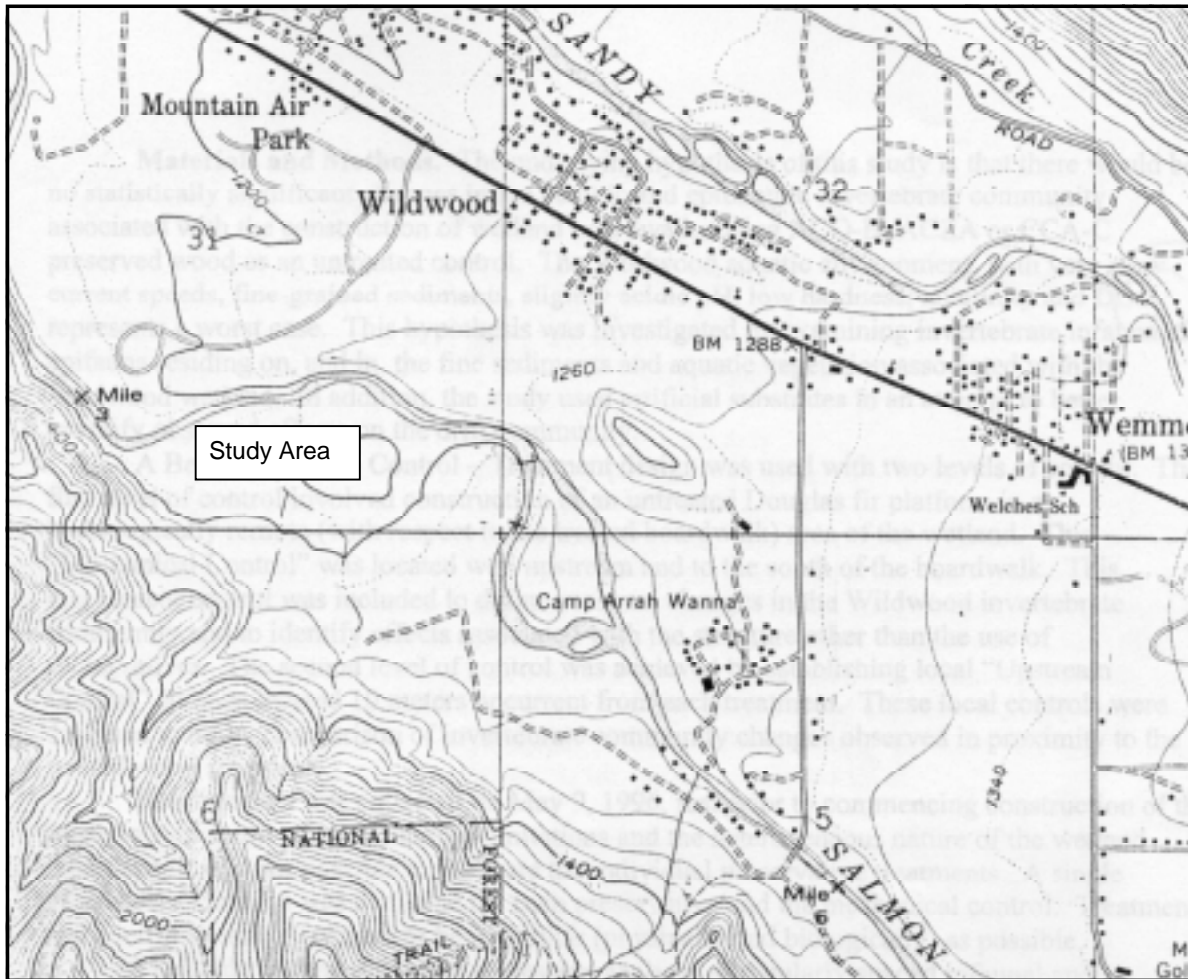

Figure II-2—Location of Wildwood Recreation Area on western slope of Mount Hood in Clackamas County, Oregon. Map courtesy of U.S. Geological Survey.

investigated by examining invertebrate infauna and epifauna residing on and in the fine sediments and aquatic vegetation associated with the Wildwood wetland. In addition, artificial substrates were used in an attempt to better quantify observed effects on the drift community.

A BATC design was used with two levels of control: “mechanical” and “upstream.” The “mechanical” level of control involved construction of an untreated Douglas-fir platform in a hydrologically remote (with respect to the treated boardwalk) area of the wetland. This control was located well upstream and to the south of the boardwalk; it was included to define seasonal changes in the Wildwood invertebrate community and to identify effects associated with the structure other than the use of preservatives. The “upstream” level of control was achieved by establishing local stations 10 m up-current from each treatment. These local controls were designed to allow comparison of invertebrate community changes observed in proximity to the treated wood structures.

Baseline data were collected on May 9, 1996, just prior to construction of the treated wood spurs. Because of funding limitations and the heterogeneous nature of the wetland landscape, it was not possible to replicate the individual preservative treatments. A single boardwalk extension was available for each preservative and the mechanical control. Treatment and control sites were chosen to be as similar (physically and biologically) as possible.

The study design allowed for regression analysis of infaunal and vegetation samples collected along transect paralleling the currents and shoreline and analysis of variance (ANOVA) for replicated artificial substrate samples. Maximum effects were anticipated in close proximity to the structures and diminishing effects at increasing distances downstream. No effects were anticipated upstream. The sampling effort was therefore focused in close proximity to the structure with reduced effort (increasing distance between samples) at greater distances (see Fig. II-2). Correlation and cluster analyses were used to identify those taxa most affected by the structure and/or metal concentrations in the

water column and sediments and to explore cause and effect relationships when significant changes in the invertebrate community were observed.

Site Selection

Site selection and the use of adequate controls were a critical part of this study. The Wildwood wetland area is a complex wetland system formed by a series of interconnecting beaver ponds and canals. Aerial photography suggests that the site lies in an abandoned channel of the Salmon River. The wetland appeared to be supplied with water from springs and a small drainage flowing from the south. Several active beaver dams hold water in the wetland year around. Water currents at the selected test locations were very slow (much less than 1 cm/s) and sediments were dominated by fines (fine sand, silt, and clay). The wetland is forested and well vegetated.

Three treatment sites and a mechanical control site were identified in March 1995. The Bureau of Land Management planned the boardwalk system so that spurs constructed of either ACQ-B-, ACZA-, or CCA-C-treated wood ran from the main boardwalk into standing water at the beaver ponds. During the planning phase, the CCA-C treatment site was relocated to a position along the main boardwalk because substrates at the original site were found to be entirely organic and contained high levels of ammonia. The chosen sites were as similar to each other as possible. They were all relatively well protected, were isolated from mechanical

disturbance, and shared the following characteristics:

- Anticipated minimum water depth of 30 cm during low summer flows
- Slow (<1 cm/s) early Spring currents
- South facing, with at least partial exposure to the sun
- Significant amounts of aquatic and emergent vegetation
- Fine sediments (primarily sand, silt, and clay)
- Shorelines that parallel the east–west axis of the wetland
- Homogeneous environment within 10 m of either side of structure

Treatment Sites

Three boardwalk extensions were constructed of treated wood. Each extension was treated with a single preservative (ACZA, ACQ-B, or CCA-C). The viewing platforms, which stood in the beaver ponds, were approximately 3.7 m wide. This provided a significant horizontal treated-wood surface area, in addition to the treated support timbers (15- by 30-cm) that were standing in water. Metal loss was associated with rainwater and the minimally flowing water around the piling. These sites were chosen to represent a worst-case situation; that is, low current speeds and fine sediments. The structures for the mechanical control, ACQ-B site, ACZA site, and CCA-C site are shown in Figure II-3.



Figure II-3—Control and treatment sites for Wildwood wetland study, 1996–1977. (a) Mechanical control site; (b) ACZA-treated wood viewing platform; (c) ACQ-B-treated wood viewing platform; (d) CCA-C-treated wood bridge.

Control Sites

Two levels of control were provided in this study: a mechanical control and a local control. Construction of a boardwalk creates significant mechanical disruption in the environment, changes in light (shading), disruption of organic flow, changes in water currents, and other such factors. A mechanical control constructed of untreated Douglas-fir was therefore included in this study. The primary advantage of this level of control is the low potential for preservative contamination. This control site was located in an isolated part of the wetland that was well upstream from the boardwalk area.

A second “local” control station was established 10 m upstream from each platform in the same beaver pond. The heterogeneous nature of the Wildwood landscape made it impossible to establish control stations further upstream. Contamination of this upstream control by preservative lost from the treated-wood viewing platforms was considered unlikely.

Sampling Procedures

Water and Sediment

Water and sediment samples for metal chemistry were collected and analyzed by the Forest Products Laboratory. The results of that portion of this study are described in part I of this publication. Note that a separate set of sediment samples were collected for the biological evaluation and metal levels reported by Lebow and others (1998a–c) may vary somewhat from the levels collected at biological sampling stations that are reported here. The following physical and chemical parameters were routinely evaluated during each sample period.

Parameter	Method of analysis
Dissolved oxygen	YSI membrane electrode, model 57
Water temperature and conductivity	YSI SCT meter
Water depth at each sample station	Meter stick
Reduction–oxidation potential discontinuity (RPD)	Clear corer and centimeter rule
Sediment grain-size distribution (SGS) ^a	Sieve and pipette (Plumb 1981)
Total suspended solids	PSEP (1986)
Total volatile solids	PSEP (1986)
Water flow (cm/s) ^b	Drogue

^aSGS was measured at beginning and end of study at each sample station.

^bAn attempt was made to measure current speeds using a Price AA current meter with a magnetic head. A drogue was used to assess current speeds, which were less than the minimum required.

Invertebrate Community

The invertebrate communities and sampling tools were as follows: infauna, Petite Ponar dredge, 0.021-m² footprint; drift community, replicated Hester–Dendy (1962) artificial substrate samplers, 0.1 m² total surface area; and vegetation, 0.027-m² footprint stovepipe.

Transects

Current speeds and direction were determined by drogue during the baseline study. The direction of drogue movement was used to define the upstream and downstream transects. Each transect was marked at its upstream and downstream terminus (12 m from perimeter of viewing platform) with a steel fence post driven into the substrate 2 m beyond the last sample station.

Distances along each transect were determined using a fiberglass tape stretched from the boardwalk to the steel fence post. Samples were collected at each treatment site (ACQ, ACZA, CCA) and the mechanical control site (Fig. II–4).

Sample Processing

On each sampling day, water column and sediments were first sampled for metals. Next, artificial substrates were removed and vegetation samples collected. Finally, infauna were sampled. All sampling started at the control station, moved to the downstream-most station, and then proceeded upstream ending at the structure.

Artificial Substrates

Three replicate Hester–Dendy substrates were suspended from a PVC pipe fixture over a 12.7-mm piece of rebar driven into the bottom of the pond (Fig. II–5). Artificial substrates were constructed of 76-mm-diameter by 3-mm-thick masonite disks separated by 3-mm-thick nylon spacers. The masonite was tempered on both sides. Eleven disks and spacers were held together on a 102-mm stainless steel eyebolt with a stainless steel wing nut. The total surface area of each sampler was 0.1 m². Substrates were installed 4 weeks before the baseline survey. They were replaced at each sampling event with new (or thoroughly cleaned and dried) substrates.

Each replicate set of three substrates was removed from the water at one time by simply lifting the PVC fixture off the rebar. Each substrate was immediately placed in a plastic bag and temporarily stored in a cooler. Individual substrates were disassembled and each disk gently washed over a 37- μ m plankton net to remove all organisms. Organisms harvested from the artificial substrates were immediately fixed in 10% buffered formalin in pre-labeled HDPE bottles.

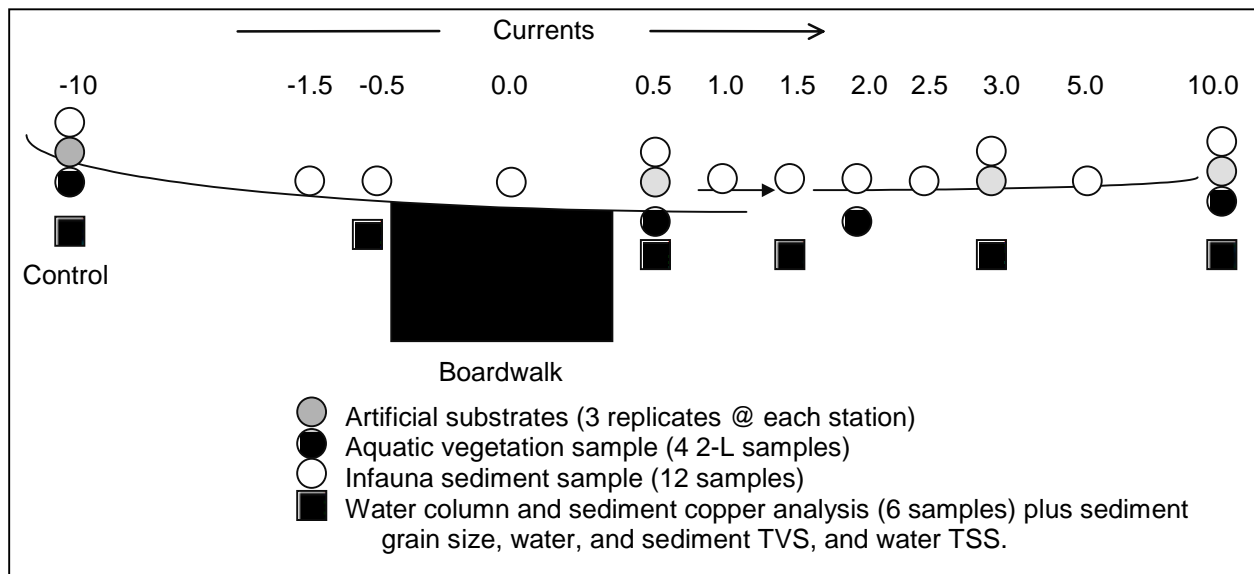

Figure II-4—Sampling locations at treatment and mechanical control sites. TVS is total volatile solids; TSS, total suspended solids.

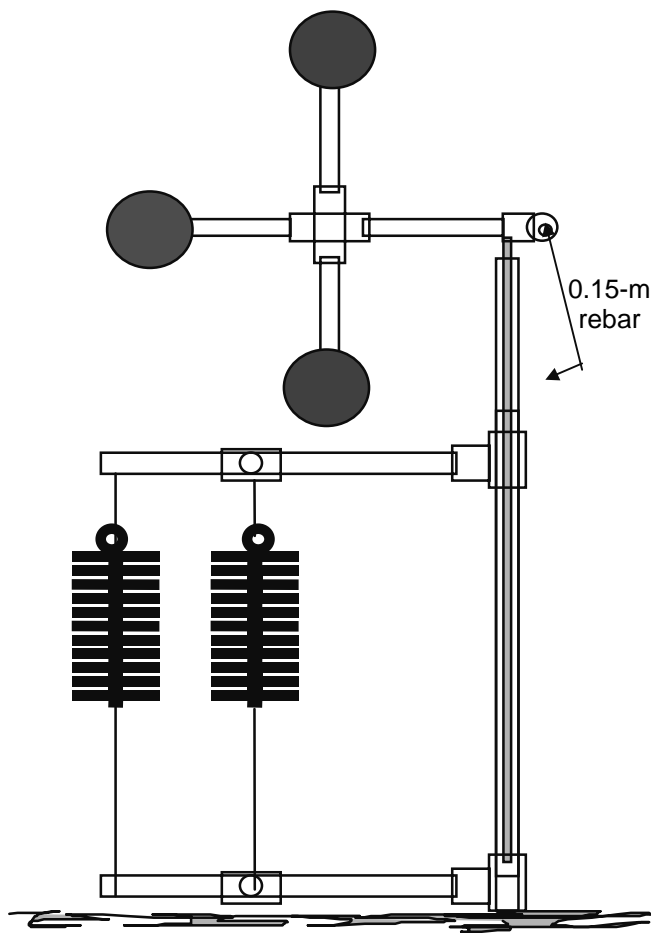

Figure II-5—PVC pipe fixture with three artificial substrate samplers. Total surface area of each sampler was 0.1 m².

Vegetation Samples

Vegetation samples were collected by inserting a piece of 20-cm-diameter stovepipe into the sediments to a depth of about 10 cm to obtain an adequate seal. All vegetation (including the root system) contained within the stovepipe was removed to a 3.8-L plastic bag. The water inside the stovepipe was then sieved through a 500- μ m mesh sieve to remove invertebrates that detached from the vegetation during recovery. This procedure usually allowed removal of nearly all water from the stovepipe that was sealed in the fine sediments.

Infaunal (Grab) Samples

Infauna are generally sessile. Coupled with the expected sedimentation of metals lost from preservatives, the infaunal community was expected to receive the longest and most chronic exposure to potential toxicants. Unreplicated, Petite Ponar dredge samples were collected at each location depicted in Figure II-3. Samples were taken so as not to resample the same sediment surface on subsequent sample days. Sediment samples were removed from the wetland and sieved on 500- μ m stainless steel screens using the park's potable water supply. All material retained on the screen was fixed in 10% buffered formaldehyde for 48 to 96 h and then preserved in 70% isopropyl alcohol. Each sample container was labeled with inner and outer labels. The inner labels followed the sample throughout its processing. Invertebrates were generally identified to genus. Chironomids were generally identified to genus, but sometimes only to family. At designated stations and sample dates, a second Petite Ponar sample was taken for sediment grain size and total volatile solids analysis. These chemistry samples included only the top 2 cm of the sediment column.

Table II–14—Number of samples collected and analyzed

Sampling day	Vegetation	Infauna	Artificial substrate	TSS and TVS ^a	Sediment grain size	Sediment and water copper
Baseline	16	48	48	24	24	48
+14 days (6/22/96)	16	48	48	—	—	48
+162 days (11/16/96)	16	48	48	—	—	48
+336 days (5/9/97)	16	48	48	24	24	48
Total	64	192	192	48	48	192

^aTSS designates total suspended solids; TVS, total volatile solids.

Sampling Schedule

Artificial substrates were set out 4 weeks prior to collection of baseline data. Originally, construction was anticipated during the summer of 1995. However, the beginning of construction was delayed until November and a decision was made to suspend all activity until the Spring of 1996 because high winter water levels would have compromised the worst-case nature of the study design. This proved to be a good decision because heavy rains caused significant flooding during the winter of 1995–1996. One beaver dam was washed out during this flooding, which would probably have significantly diluted any preservative lost from the treated wood and flushed it down river. The sampling schedule for 1996 and 1997 is shown in Table II–13.

Number of Samples

The matrix in Table II–14 describes the number of samples collected and analyzed. Environmental measurements were collected from each treatment site and the control site on each sample day.

Taxonomy

Invertebrates were retrieved from the background matrix under a microscope at 10 to 40× magnification. For quality assurance, a second technician checked 10% of the samples. If this technician found that more than 5% of the insects were missed in the original “pick,” then all the samples were re-picked.

Invertebrates were identified to the lowest practical level (generally genus for all orders except Chironomids, which were sometimes identified only to family or tribe). A reference collection containing representative samples for each taxon was developed and was archived in 70% alcohol. After identification, all samples were archived. The reference collection will be retained permanently. The individual samples are being retained for 3 years (until May 2000).

Analytical Procedures

Sediment Grain Size

Sediment grain size samples were stored at 4°C until analysis. The sediments were dried in an oven at 92°C and processed using the dry sieve and pipette method of Plumb (1981). Sieves used for sediment analysis had mesh openings of 2, 0.89, 0.25, and 0.063 mm. Particles passing through the 0.063-mm sieve were analyzed by sinking rates in a column of water (pipette analysis). Quality assurance checks included triplicate analyses for 1 in 20 samples with a $\pm 20\%$ relative standard deviation (RSD) criterion.

Sediment Total Volatile Solids

New aluminum evaporating dishes were ignited at 550°C for 1 h in a muffle furnace to remove all organic material. The dishes were cooled in a desiccator and weighed to the nearest 0.1 mg. The sediment sample was thoroughly homogenized and 20 to 30 g placed in the previously ignited dish. The sample was dried to a constant weight at $103 \pm 2^\circ\text{C}$, weighed to the nearest 0.1 mg, ignited at $550 \pm 10^\circ\text{C}$ for 1 h, cooled in a desiccator, and reweighed. Total volatile solids (TVS) was calculated as the weight loss on ignition divided by the dried weight, expressed as a percentage. Brooks (unpublished data) found that total organic carbon is approximately equal to $0.61 \times$ total volatile solids in marine environments.

Water Total Suspended Solids (APHA Method 2540 D)

A representative water sample (approximately 300 mL) was thoroughly mixed, filtered through a 45- μm glass filter previously washed at 550°C, and weighed. The filter was washed 3× with 10 mL distilled water, with complete drainage between washings. Suction was continued for 3 min after filtration had finished. The filter was then dried at $103 \pm 2^\circ\text{C}$ until no weight loss was recorded on successive weighings to 0.1 mg. The difference between the original weight of the filter and the weight with dried residue was considered the total suspended solids (TSS), expressed as milligrams per liter.

Water Total Volatile Solids (APHA Method 2540 B)

The filter containing the residue used to measure TSS was ashed at 550°C in a muffle furnace for 1 h and re-weighed. The weight loss on ignition, was considered the total volatile solids (TVS), expressed as milligrams per liter. Quality assurance involved weekly calibration of the four-place balance, routine running of blank filters, and triplicate analyses on 5% of the samples (minimum of 1 sample) with a 35% RSD.

Data Analysis

Observed taxa were recorded in a Microsoft Excel spreadsheet for partial analysis and imported into Statistica for more rigorous statistical analysis. Regression analysis was used to evaluate the infaunal data and ANOVA was used for the replicated artificial substrate data. In the graphs, lines were fitted using distance-weighted least-squares analysis. Principal components analysis and correlation analysis were used to search for meaningful relationships between the structures, water and sediment levels of copper, chrome, arsenic, and zinc, and invertebrate response.

Study Endpoints

The purpose of this study was to document the response of aquatic invertebrates to both the mechanical effects associated with boardwalks in inundated wetlands and the effects of using CCA-, ACZA-, and ACQ-treated wood in their construction. The study was designed to assess changes in invertebrate communities under the worst possible conditions: large surface areas of treated wood located in and adjacent to water of low hardness and alkalinity that was flowing at very slow speeds over fine-grained sediments. Endpoints were chosen to identify sensitive taxa and to determine the statistical significance of changes in several endpoints. These changes were documented in both spatial and temporal frames of reference. The following specific endpoints were evaluated in this effort:

1. Total species richness (total number of taxa) and Margalef's (1958) richness index—The area sampled within each sample type (vegetation, artificial substrate, infauna) was uniform throughout this study. This statement is somewhat misleading with respect to the vegetation samples because the two-dimensional area sampled (a 20-cm diameter stovepipe) did not take into account the surface area of the plants, which exist in three-dimensional space. Ludwig and Reynolds (1988) discussed the underlying assumption for a functional relationship of the form $S = k\sqrt{n}$ between the number of taxa (S) and the number of organisms in the sample (n). This relationship was not found in the Wildwood database and valid conclusions were unlikely to follow from the analysis of Margalef's index. Ludwig and Reynolds (1988) noted that simple

species richness (S) is a more appropriate endpoint when sample sizes are equal. This analysis will evaluate the number of taxa (S).

2. Total sample abundance—This endpoint simply represented the number of organisms in a single sample. This metric is useful in identifying environments where stress is severe enough to adversely affect all taxa, including those that are normally tolerant of the stressor. It is not a useful metric for assessing subtle effects that adversely affect intolerant species that are replaced, numerically, by tolerant species.
3. Dominant sample abundance—Dominant taxa were identified as those representing at least 1% of the total number of individuals in a series of samples (vegetation, artificial substrates, or infauna). Correlation analysis was then used to examine the relationship between the abundance of these dominant taxa and sediment or water column concentrations of copper, chrome, arsenic, and zinc. Based on this analysis, Annelids were dropped from the list of dominant taxa because they were not sensitive to metal intoxication at the levels observed in this study and because their very high abundance in all samples would likely mask decreases associated with less tolerant and abundant taxa. The resulting group of dominant taxa are considered those most likely to reveal adverse effects. The identification of these taxa will be discussed later in this report.
4. Shannon's index (Shannon and Weaver 1949)—This index provides the average uncertainty per species in an infinite community of taxa. The form of the index used in this analysis is given by Equation (3). The value of Shannon's index is zero when a single species is present. This value is maximized when there are a large number of equally represented species and is reduced in communities dominated by a few highly abundant species. The value of Shannon's index in a sample containing 20 taxa equally represented in a total abundance of 600 animals would be 3.0.

$$H' = -\sum_{i=1}^S (n_i/n) \ln(n_i/n) \quad (3)$$

where the sum is for S taxa.

5. Pielou's index—The Pielou index (Pielou 1977) is a commonly used measure of community evenness. It expresses the observed value of Shannon's index relative to the maximum possible value ($\ln(S^*)$). Pielou's index varies between 0 and 1.0 and generally co-varies with Shannon's index

$$J' = H'/\ln(S^*) \quad (4)$$

where H' is Shannon's index and S^* is number of taxa.

Results

The results for each preservative (ACQ-B, ACZA, and CCA-C) will be provided separately after a general description of the study area and baseline conditions.

Characterization of Study Area

Figure II-6 describes the location of the site and the configuration of the boardwalk. As viewed from the air, the Wildwood recreational area appears to be located in an abandoned channel of the Salmon River.

Rainfall

Data on rainfall during the study period are shown in Figure II-7. Daily rain varied between zero throughout much of the summer to 6 cm in early December. Thus, water flow through the wetland varied by season and maintenance of wetland hydrology was highly dependent on the water retained behind the beaver dams.

Wetland Water Levels

Water flow in the Wildwood wetland was influenced by rainfall and snowmelt. The beaver dam at the ACZA treatment site was washed out during the winter of 1995-96. This dam was reconstructed using sandbags, fiberglass filter cloth, mud, and logs by the Bureau of Land Management. The reconstructed dam functioned properly during the entire study and beaver activity was observed in the pond behind this dam during 1997.

The existing network of dams functioned to maintain a minimal water table at each study site throughout the study. However, water depths were highly variable in the pools. Sample stations on upstream and downstream transects followed the currents and shoreline. All invertebrate samples were collected in water between 30 and 45 cm deep, except at the control station where water immediately adjacent to the untreated wood platform was generally 50 to 70 cm deep.

Physicochemical Properties of Wetland Water

The variability in rainfall (Fig. II-7) had subtle effects on the water flowing through the Wildwood wetland system. The physical and chemical properties of the water were further affected by snowmelt in the spring and early summer months. Table II-15 summarizes the physicochemical properties measured in the Wildwood wetland during the study survey.

Total suspended solids (TSS) and total volatile solids (TVS) in the water column were not significantly different as a function of either season or treatment (ANOVA, $p = 0.34$ and 0.25 , respectively). The ANOVA indicated that turbidity was significantly higher ($\alpha = 0.05$) at the CCA-C treatment site compared with that of the control, ACQ, or ACZA sites ($p = 0.009$). However, turbidity values were low at all times and treatments. Dissolved oxygen levels were above the

levels required to support sensitive species except during the summer, when the level of 5.7 mg/L was marginally lower than the minimum level (6.0 mg/L) considered necessary for optimal salmonid growth. Dissolved oxygen was measured at each treatment site at approximately 8 a.m. on the morning of June 23, 1996. It is likely that dissolved oxygen levels increased and peaked near sunset during the summer. Minimal levels would have likely occurred during the early morning hours before sunrise (3 to 4 a.m.) and may have been lower than the recorded value of 5.7 mg/L. Note that all the treatment sites were located in backwaters where currents were very slow and large quantities of living vegetation were observed. Dissolved oxygen levels in the main channels were possibly higher, providing a refuge for fish, which were frequently observed in the wetland. However, all of this is speculation because of the few measurements taken.

There was a slight increase (not statistically significant) in pH during the summer months. This was likely associated with increased plant photosynthesis, which may have reduced levels of carbonic acid in the water. These data indicated that the physicochemical properties of this wetland were relatively stable and that water generally contained little particulate inorganic or organic matter. The water appeared generally well-oxygenated with neutral to slightly acidic pH.

Hardness, Alkalinity, and Dissolved Organic Carbon

Hardness was measured during August and December 1996. The August values averaged 22 mg/L (as CaCO_3); values were lower (15 mg/L) in December. The alkalinity value of 19.5 mg/kg was very close to the average hardness, suggesting essentially no non-carbonate hardness. These low values were consistent with the relatively new geologic history of the Mount Hood area and general lack of calcium and magnesium in the soils. From the point of view of metal chemistry, these values suggested minimal complexation and detoxification of metals. The EPA chronic criteria for copper, chrome arsenic, and zinc under these conditions are given in Table II-16. These values were used as benchmarks against which to assess toxicity in the water column.

Dissolved organic carbon (DOC) is also capable of complexing and detoxifying metals. Three water samples were analyzed at each treatment station in Spring 1997. Mean DOC values ranged from 0.56 mg DOC/L at the remote control site to 0.84 mg DOC/L at the CCA-C treatment site. Significant differences ($\alpha = 0.05$) were not observed in DOC levels between treatment sites. However, water enters the wetland complex near the control site and water entering the CCA-C treatment site transits the greatest length of the wetland environment. This suggests that DOC is accumulating in the water column as it passes through the wetland. The observed low levels of DOC in the water column suggest minimal detoxification of metal (particularly copper) ions in this compartment.

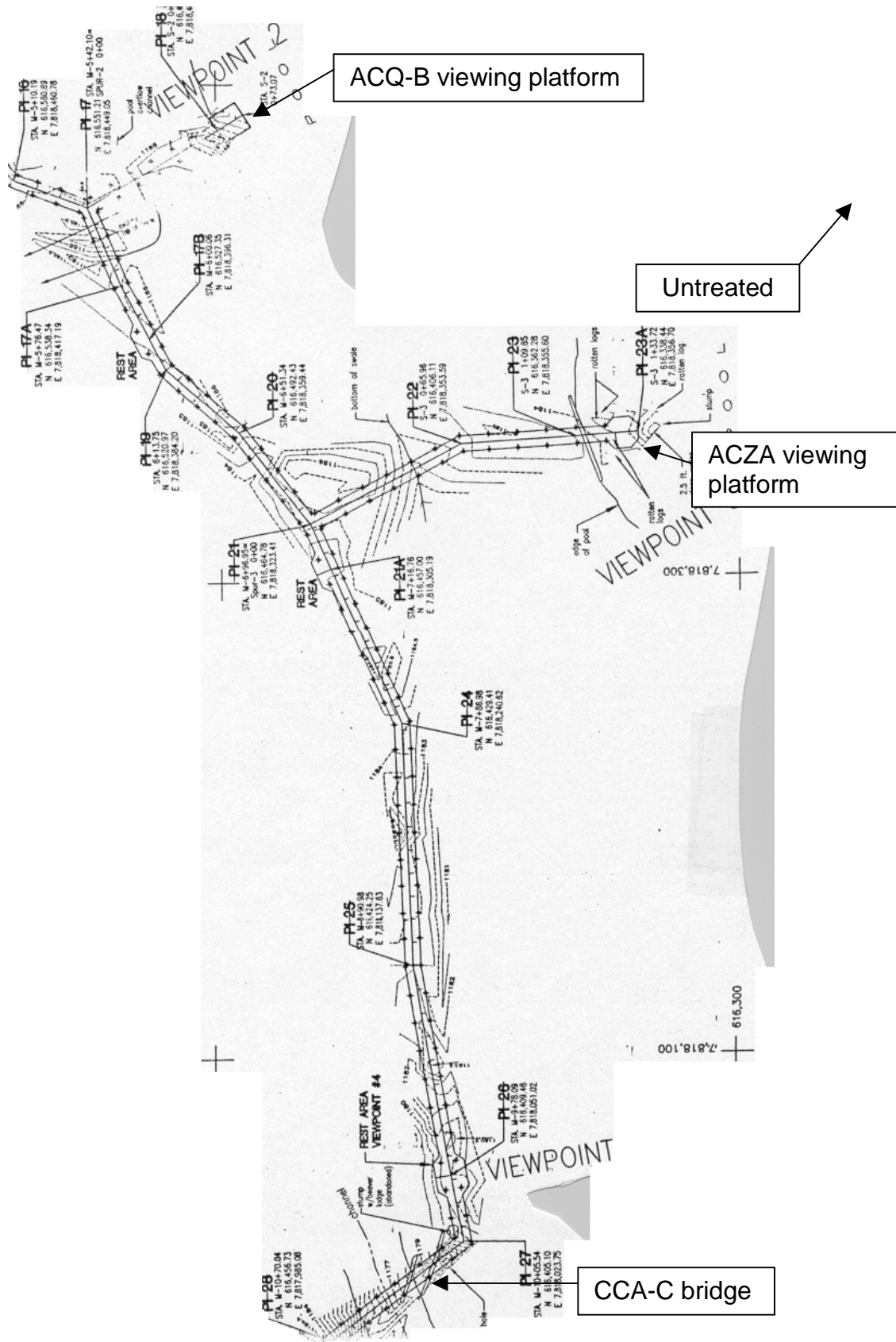

Figure II-6—Location of study areas and configuration of boardwalk system.

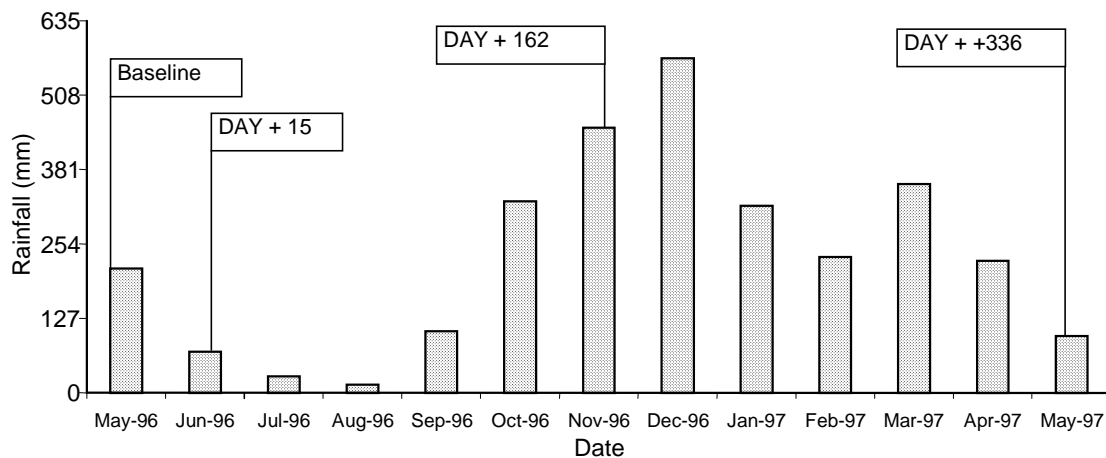

Figure II-7—Rainfall data recorded in Brightwood, Oregon from May 1996 to May 1997. Flags indicate sampling days.

Table II-15—Physicochemical properties of water flowing through Wildwood wetland area as function of sampling date

Date	TSS (g/L)	TVS (g/L)	Dissolved oxygen (ppm)	pH	Temperature (°C)	Turbidity (NTU)
May 9, 1996	0.00200	0.00193	9.0	6.4	8.9	1.30
June 22, 1996	0.00130	0.00130	5.7	6.9	15.7	2.36
November 16, 1996	0.00450	0.00214	8.4	7.0	8.0	0.90
May 9, 1997	0.00734	0.00150	9.1	6.6	11.6	1.54

Table II-16—EPA chronic metal water quality criteria for fresh water

Metal	Criterion (µg/L)	Criterion hardness (as CaCO ₃) (µg/L)
Arsenic	≤50	≤50.00
Copper	0.862 exp(0.8545[ln H] - 1.465)	≤2.68
Chrome III	exp(0.8190[ln H] + 1.561)	≤49.89
Chrome VI	≤11	≤11.00
Zinc	0.8910 exp(0.8473[ln H] + 0.7614)	≤22.61

Table II-17—Silt-clay fines and sediment total volatile solids observed in Wildwood study at each treatment site

Study site	Silt-clay fines (%)	Sediment TVS (% by weight)
Control	50.0	0.205
ACQ-B	53.3	0.151
ACZA	59.5	0.284
CCA-C	47.3	0.185

Physicochemical Properties of Wetland Sediments

The physical characteristics of sediments were assessed during the baseline study (day -29) and on day 336. Significant differences in the spatial or temporal distribution of sediment grain size and TVS were not observed (Table II-17). The sediment matrix in the Wildwood wetland is dominated by sand, silt, and clay and has a low organic

content when living plants are excluded from the analysis. Beaver channels were generally dug down to the underlying glacier till (approximately 50 cm deep). These channels contained scattered rocks and gravel. Beaver channels were avoided as sampling areas. The fine sediments should have efficiently bound copper lost from the structures. However, the reduction oxidation potential discontinuity (RPD) was not observed in any of these sediments, indicating aerobic

conditions at all sample stations and the potential for recycling of copper from the sediments back into the water column. Reducing conditions were observed in sediments in some areas of the Wildwood wetland. However, these areas were avoided during project planning because of the adverse effects that reducing conditions (low dissolved oxygen, hydrogen sulfide, and ammonia) were expected to have on infauna.

Summary of Physicochemical Properties in Wildwood Area

All biological sample stations remained submerged during this study. The Wildwood wetland water contained minimal amounts of suspended material and most filterable residue was organic in nature. Temperature, dissolved oxygen, and pH were variable, but within an acceptable range for nearly all invertebrates. The low hardness, alkalinity, and minimal DOC in water passing through the Wildwood wetland suggest minimal detoxification of metals lost from treated wood. When coupled with the slow (not measurable in most cases) current speeds around the treated wood structures in this study, the physicochemical properties of the water column suggest that this is, in fact, a worst-case study. The sediment matrix was dominated by sand, silt, and clay without significant amounts of small organic material. All treatment sites contained significant amounts of woody debris associated with beaver activity. This solid material was not included in the DOC analysis and would likely have little ability to bind free metals.

Observed seasonal changes in physicochemical parameters were generally consistent throughout the wetland and were not significantly different between the control and treatment stations on any sample day. These results do not suggest significant physicochemical stressors on the aquatic invertebrates evaluated in this study. This simplifies the assessment, making it more likely that changes in the insect community structure are associated with the wooden structures rather than with other factors.

Invertebrate Community—Baseline Survey

A baseline survey was conducted on May 9 and 10, 1996. Descriptive statistics for sediment metal concentrations observed during the baseline study are provided in Table II–18.

Recorded baseline metal levels were all lower than the threshold effects concentration (TEC) and “high no-effect” concentration (NEC) reported in the Assessment and Remediation of Contaminated Sediments Program (Jones and others 1997). The variance to mean ratios for chrome, copper, and arsenic were less than 1, indicating that these metals are regularly (evenly) distributed in sediments. The variance to mean ratio for zinc (1.56) suggests a slightly patchy distribution for this metal.

The aquatic invertebrate community is discussed with emphasis on the baseline survey. A total of 86,144 invertebrates in 151 taxa were identified in the 424 samples collected (see Appendix II for an inventory of taxa identified). For each type of sample (artificial substrates, infauna, and vegetation), taxa were considered “dominant” if they represented at least 1% of the total abundance. Similarly, taxa were considered “rare” if they accounted for less than 1.0% of the total abundance. Only dominant taxa were included in the abundance analysis. Dominant taxa are described for the baseline study in Tables II–19 to II–21.

Baseline Vegetation Samples

All vegetation, roots, and substrate were collected within the confines of a piece of 20-cm-diameter stovepipe pushed approximately 10 cm into the sediment. Sixteen baseline vegetation samples collected on May 9 and 10, 1996, contained a total of 4,154 invertebrates in 55 taxa. Of these, 14 taxa were dominant and 39 rare. The dominant taxa are identified in Table II–19. The 14 dominant taxa accounted for 92% of the total number of invertebrates inventoried. The 39 rare taxa represented 8% of the total number.

Table II–18—Baseline sediment metal concentrations observed in Wildwood wetland on May 9, 1996

Metal	Metal concentration (mg/kg dry sediment)					
	Arithmetic mean	Median	Variance	Variance to mean ratio	ARCS TEC ^a	ARCS NEC ^a
Chrome	10.4	10.0	7.2	0.69	56.0	312.0
Copper	21.0	21.0	7.7	0.37	28.0	54.8
Arsenic	2.6	2.0	1.3	0.50	12.1	92.6
Zinc	53.0	54.8	82.8	1.56	159.0	541.0

^aAssessment and remediation of contaminated sediments program (Jones and others 1997). TEC is threshold effects level and NEC, high no-effect concentration (EPA 1996).

Table II–19—Common and uncommon species observed in 16 vegetation samples collected during baseline survey^a

Dominant taxa	Total abundance	Number of samples
Nematoda	54	10
Annelida	1,551	16
Mollusks		
<i>Lanx</i> sp.	68	10
<i>Gyraulus</i> sp.	210	12
<i>Pisidium</i> sp.	562	16
Acarina	85	11
Isopoda		
<i>Caecidotea</i> sp.	281	14
Ephemeroptera		
<i>Paraleptophlebia</i> sp.	257	11
Diptera		
Ceratopogoninae	105	15
Chironomidae	103	16
<i>Larsia</i> sp.	280	15
<i>Psectrotanypus</i> sp.	36	11
<i>Tanytarsus</i> sp.	81	6
<i>Eukiefferiella</i> sp.	149	6

^aTotal abundance is number of individuals found in all 16 samples. Number of samples denotes samples in which particular taxon was identified.

Baseline Artificial Substrate Samples

Three replicate sets of Hester–Dendy (1962) artificial substrates were maintained at the –10, +0.5, +3.0 and +10-m stations. These substrates were placed in the wetland during April 1996 and had been in place for approximately 4 wk when baseline data were collected. A total of 2,073 invertebrates in 46 taxa were collected from the 48 samplers. The 19 taxa identified in Table II–20 were dominant on artificial substrates and accounted for 74% of the total number of organisms.

Baseline Infaunal Samples

Twelve Petite Ponar grab samples were collected at each treatment site during the baseline survey. Samples were collected at –10, –1.5, –0.5, 0, 0.5, 1.0, 1.5, 2.0, 2.5, 3.0, 5.0, and 10 m from the marked location of the viewing platform. A total of 10,854 invertebrates were inventoried in 38 taxa. The eight dominant taxa represented 95% of the total abundance. The abundance of *Sialis* sp. (Megaloptera) approached the required level of 109 for inclusion as dominant. In addition, this species was found in 35 of 48 samples and was therefore included as dominant. It should be noted that Annelids, Mollusks (*Pisidium* sp.), and *Larsia* sp. accounted for 84% of the total. Dominant infaunal species observed during the baseline study are described in Table II–21.

Tolerance of Dominant Taxa to Copper

Table II–22 summarizes dominant taxa representing >1% of the total community evaluated during the survey for each

Table II–20—Dominant invertebrates collected on Hester–Dendy artificial substrate samplers during baseline survey^a

Dominant taxa	Total abundance	Number of samples
Nematoda	53	12
Annelida	303	34
Molluska		
<i>Lanx</i> sp.	68	22
<i>Gyraulus</i> sp.	33	15
<i>Pisidium</i> sp.	31	12
Copepoda		
Cyclopoida	32	17
Isopoda		
<i>Caecidotea</i> sp.	83	18
Colembola		
Isotomidae	25	11
Ephemeroptera		
<i>Baetis</i> sp.	37	9
<i>Paraleptophlebia</i> sp.	46	19
Plecoptera		
<i>Amphinemura</i> sp.	23	7
Diptera		
Ceratopogoninae	54	18
Chironomidae	39	12
<i>Larsia</i> sp.	114	27
<i>Chironomus</i> sp.	729	33
<i>Tanytarsus</i> sp.	80	29
<i>Rheosmittia</i> sp.	152	31
<i>Eukiefferiella</i> sp.	34	9

^aTaxa were represented at >1% of total abundance. Total of 48 samples were collected.

Table II–21—Dominant infaunal invertebrates collected in Petite Ponar grab samples during baseline survey^a

Dominant taxa	Total abundance	Number of samples
Annelida	3,157	47
Molluska		
<i>Pisidium</i> sp.	4,694	46
Megaloptera		
<i>Sialis</i> sp.	95	35
Diptera		
Chironomidae		
<i>Larsia</i> sp.	1,288	44
<i>Procladius</i> sp.	174	34
<i>Psectrotanypus</i> sp.	577	47
<i>Polypedilum</i> sp.	110	20
<i>Tanytarsus</i> sp.	251	40

^aTaxa were represented at >1% of total abundance. Total of 48 samples were collected.

Table II–22—Taxa identified as dominant in Wildwood invertebrate inventory

Dominant taxa	Infauna	Artificial substrates (no.)	Vegetation (no.)	Copper tolerance ^a	Correlation coefficient ^b	
					Water Cu, artificial substrate/vegetation	Sediment Cu, infauna
Nematoda	726	279	144		–0.06/–0.19	0.04
Annelida						
<i>Limnodrilus</i> sp.	19,938	3,127	1,885	Not an indicator	–0.08/+0.06	–0.08
Mollusca						
<i>Lanx</i> sp.	81	623	157	Slightly intolerant	–0.19/–0.37	<u>+0.72***</u>
<i>Gyraulus</i> sp.	167	566	286	Moderately intolerant	–0.14/–0.53	
<i>Pisidium</i> sp.	18,616	147	1,181	Not an indicator	–0.10/+0.22	–0.20
Acarina	77	27	121	Not an indicator	/–0.24	
Copepoda						
Cyclopoida	445	260	126	Not an indicator	–0.12/+0.00	
Isopoda						
<i>Caecidotea</i> sp.	1,127	312	831	Not an indicator	+0.25/–0.09	–0.14
Ephemeroptera						
<i>Paraleptophlebia</i> sp.	135	1,967	420	Slightly intolerant	–0.17/–0.33	
Trichoptera						
<i>Psychoglypha</i> sp.	52	4	127	Not an indicator		+0.15
Diptera						
Ceratopogoninae	8,271	441	172	Not an indicator	–0.01/+0.24	–0.04
Chironomidae	185	156	223	Slightly intolerant	–0.10/–0.31	
<i>Larsia</i> sp.	4,233	504	781	Not an indicator		–0.12
<i>Psectrotanypus</i> sp.	2,115	22	14	Not an indicator		–0.09
<i>Chironomus</i> sp.	922	865	2	Not an indicator	+0.10/	–0.03
<i>Polypedilum</i> sp.	0.642	35	102	Not an indicator		–0.11
<i>Tanytarsus</i> sp.	6,652	811	595	Intolerant	–0.13/–0.18	<u>+0.53***</u>
<i>Rheosmittia</i> sp.	190	662	60	Slightly intolerant	–0.19/–0.49	+0.37
<i>Eukiefferiella</i> sp.	1,233	626	362	Not an indicator	–0.17/–0.34	+0.03
Dominant taxa abundance	—	—	—	Intolerant to dissolved Cu	<u>–0.21*/–0.12</u>	+0.10
Taxa richness (no. taxa)	—	—	—	Intolerant to dissolved Cu	<u>–0.26**</u> – <u>–0.36*</u>	+0.02
Total dominant	57,031	12,123	10,411			
Total invertebrate	61,588	12,943	11,613			
Percent dominant	93%	94%	90%			

^aPrevious level of tolerance identified in literature.

^bPearson correlation coefficients relate abundance of each taxon with water column copper levels for artificial substrate and vegetation samples and with sediment levels for infaunal samples. Correlation coefficients with $p = 0$ or <0.15 are underlined.

* $\alpha = 0.15$

** $\alpha = 0.10$

*** $\alpha = 0.05$

type of sample (vegetation, infauna, and artificial substrate). Pearson correlation coefficients are provided between individual taxa found on vegetation and artificial substrates and levels of copper measured in the water column on day 15, when the highest water column concentrations were observed. Pearson correlation coefficients are also provided for infauna compared with sediment concentrations of copper on day 336, when the highest levels of sedimented copper were observed.

The data in Table II-22 do not suggest a clear pattern of tolerance or intolerance to copper within the range of concentrations observed in this study (16.5 to 304 mg Cu/kg dry sediment weight and 0.2 to 102 µg Cu/L). This is particularly true for infauna when compared with sedimented copper at the end of the study. Only significantly positive ($\alpha = 0.05$) correlations were observed for infauna.

Nematodes will be excluded from further assessment because they were not significantly intolerant of copper and because the use of a 500-µm screen to sieve the samples caused the loss of an undetermined number of individuals.

Limnodrilus sp. appeared somewhat tolerant to copper, chrome, and arsenic in sediments. Significant positive correlations were observed with sedimented arsenic ($r = +0.52$, $p = 0.001$), and chrome ($r = +0.45$, $p = 0.005$). A negative correlation was observed with zinc, but it was not significant. *Limnodrilus* sp. did not appear to be a sensitive indicator of adverse effects associated with metals lost from treated wood in this study. Since the high abundance might have masked effects observed in more sensitive species, *Limnodrilus* was excluded from the analysis.

Mollusks, *Lanx* sp., and *Gyraulus* sp. were found in abundance only on vegetation and on artificial substrates. They appeared slightly intolerant of copper. *Pisidium* sp. was not considered a good indicator; it was included in the infaunal but not in the artificial substrate or vegetation analyses.

All other dominant taxa described in Table II-22 were included in the analysis. Canfield and Canfield (1994) suggest that direct taxa richness (number of taxa per station) has historically been found to be a sensitive measure of community response to contaminants. In the study reported here, the negative correlation between water column concentrations of copper and total taxa richness was significant ($\alpha = 0.05$) on both artificial substrates and vegetation.

Invertebrate Community—Mechanical Control

Artificial Substrates

The abundance of invertebrates observed on artificial substrates as a function of time and distance from the mechanical control is described in Figure II-8. Similarly, the number of taxa observed on artificial substrates is described in Figure II-9.

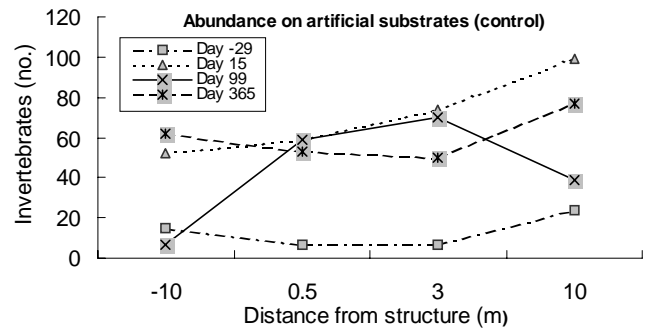

Figure II-8—Total abundance of infauna collected on 10-plate Hester-Dendy artificial substrate collectors at mechanical control site.

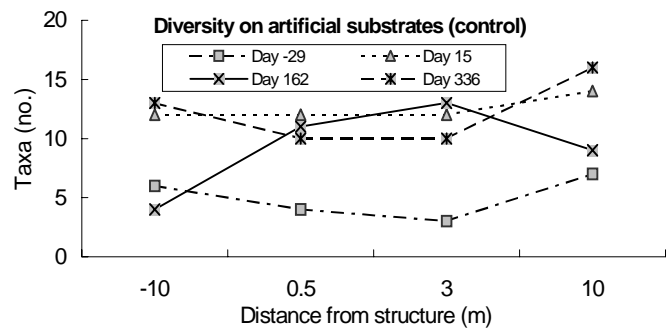

Figure II-9—Number of taxa collected on 10-plate Hester-Dendy artificial substrate collectors at mechanical control site.

Invertebrate abundance increased from an initial low of about 10 to 15 invertebrates/collector during the baseline survey to >50 in the immediate vicinity of the untreated wood structure at all other sample times. The ANOVA indicated that distance was not a significant factor at the mechanical control site except on day 162, when the stations located at -10 and +10 m held significantly fewer invertebrates than did the stations closest to the structure.

However, the abundance and number of taxa observed on different sampling dates was significantly different ($\alpha = 0.05$). These data are provided in Table II-23. Post hoc testing revealed that taxa richness during the baseline survey was significantly lower than that at any other time. In addition, the number of taxa observed on November 16, 1996 (day 162) was significantly lower than that observed during the Spring (days +15 and +336). The depressed community observed during the baseline survey is unexplained. The decreases in abundance and richness observed during the Fall were likely due to the change in season. This factor could be expected to affect all treatment sites equally during Fall sampling.

The abundance and number of invertebrate taxa observed on vegetation samples on various sampling days are shown in Table II-23 and in Figures II-10 and II-11. The ANOVA indicated that both abundance and taxa richness of samples

Table II-23—Taxa observed on artificial substrates and vegetation at mechanical control site on various sampling days^a

Substrate and clay	Number	Total abundance
Artificial substrate		
Day -29	<u>5</u>	<u>13</u>
Day +15	12	71
Day +162	<u>9</u>	<u>44</u>
Day +336	12	61
Vegetation		
Day -29	21	272
Day +15	<u>16</u>	194
Day +162	7	<u>53</u>
Day +336	22	183

^aValues significantly ($\alpha = 0.05$) lower than highest value are underlined. Values asre means.

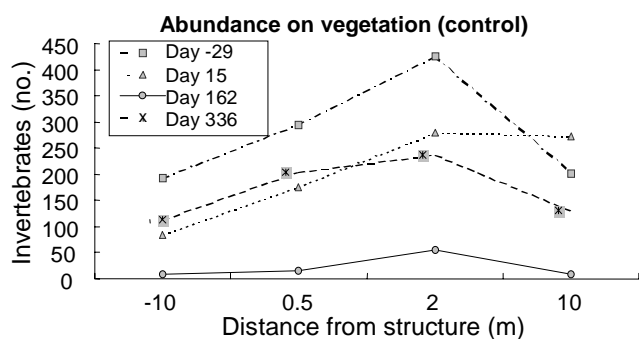

Figure II-10—Total abundance of invertebrates collected from vegetation and sediments within area defined by 20-cm stovepipe at mechanical control site.

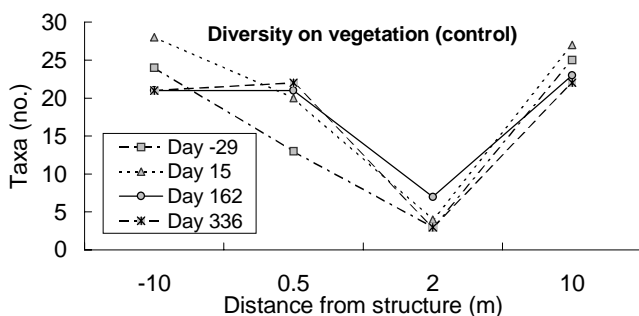

Figure II-11—Total taxa richness for invertebrates collected from vegetation and sediments within area defined by 20-cm stovepipe at mechanical control site.

collected from vegetation were significantly different as a function of day ($p = 0.000$) but not as a function of distance ($p = 0.089$). The lack of significance associated with distance was due to the paucity of samples and high variability between samples (single samples were collected at each distance on each day, giving a total of four replicates/day). Similar to the artificial substrate results, a reduction in both abundance and taxa richness was observed in the Fall of 1996 (day +162). Data from the single vegetation samples collected on each sampling date at four distances from each treated wood structure were not used to test hypotheses regarding the effects of the various wood preservatives. However, the vegetation community was compared with results observed on artificial substrates to substantiate observed effects (or lack thereof).

Infauna

Total infaunal taxa abundance and richness are described in Figures II-12 and II-13. The data are highly variable. Fourth-order polynomial fits to the data are provided to simplify the visual interpretation. The infaunal data were analyzed using multiple regression analysis in Statistica software. The abundance of infauna at the mechanical control site was a function of distance ($p = 0.05$), but not of day ($p = 0.56$). The regression was significant ($p < 0.047$) but explained only 8% of the variation in the database. The expression for abundance at the mechanical control site is provided in Equation (5). The given relationship predicts maximum abundance upstream with a gradual decrease of 13.6 organisms per meter traveled downstream. The mean abundance and taxa richness at the mechanical control site was 369 ± 41 organisms in 14 ± 4 taxa. Values are mean $\pm 95\%$ confidence intervals. Abundance and diversity were reasonably well-correlated (Pearson correlation coefficient of 0.51), suggesting that differences in abundance were associated with the entire community and not with one or two taxa.

$$\text{Abundance} = 384.3 - 13.6 \times \text{distance (m)} \quad (5)$$

Taxa richness at the mechanical control site was significantly influenced by day ($p = 0.002$), but not by distance ($p = 0.586$) (Fig. II-13). The regression equation (Eq. (6)) was significant ($p < 0.0179$) but did not explain a significant amount of the variation (17.5%). The relationship in Equation (6) suggests that taxa richness increased by 5 during the 365-day study.

$$\text{Taxa richness} = 12.5 + 0.01 \times \text{day} \quad (6)$$

Summary for Mechanical Control

The dominant taxa abundance and richness associated with samples collected from artificial substrates, vegetation, and sediments (infauna) are summarized in Table II-24. Currents at all treatment sites were essentially undetectable in the immediate vicinity of the wood platforms, except at the CCA-C site where 3- to 5-cm/s currents were found in a very small channel surrounded by still water. Because of

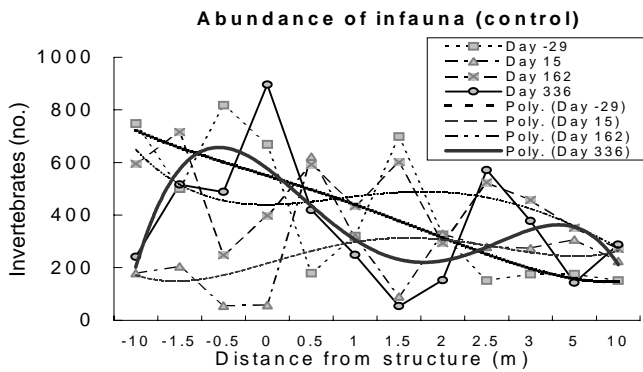

Figure II-12—Abundance of infauna collected at varying distances and times from untreated mechanical control structure.

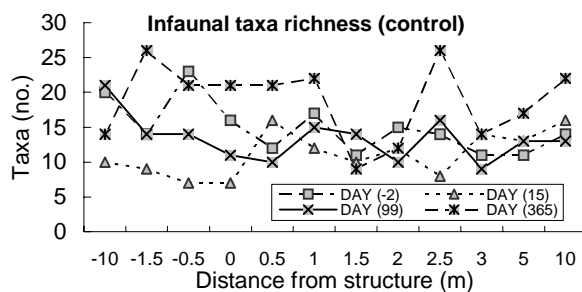

Figure II-13—Infaunal taxa richness observed at untreated mechanical control structure.

Table II-24—Total taxa richness and dominant taxa abundance observed on artificial substrates on vegetation and in sediments at mechanical control site

Sam-pling day	Total taxa richness			Dominant taxa abundance		
	Artif. sub-strates	Vege-tation	In-fauna	Artif. sub-strates	Vege-tation	In-fauna
-29	21	5	14	272	13	409
+15	16	12	11	194	71	245
+162	7	9	13	53	44	456
+336	22	12	18	183	61	366

these slow currents, the drift community was not expected to contribute significantly to this community analysis. However, more invertebrates representing more taxa were collected on artificial substrates than on vegetation. Distance did not have a statistically significant effect ($p = 0.026$) on either the abundance or diversity of invertebrates collected on artificial substrates in this study. Significant differences were observed in both richness ($p = 0.000$) and abundance ($p = 0.000$) as a function of sampling date. This was particularly evident in the reduced community observed during the Fall (day +162). Therefore, effects on the artificial substrate community,

associated with the various treated wood structures, were analyzed using ANOVA with distance as the independent variable.

The invertebrate community collected from vegetation at the mechanical control site was the least diverse and abundant. This community also demonstrated significant variability as a function of date ($p = 0.000$) but not of distance ($p = 0.13$). Vegetation samples were not used to test hypotheses regarding the effects of the various wood preservatives evaluated in this study because only single vegetation samples were collected at each distance on each day. However, the community observed on vegetation was compared qualitatively with the artificial substrate samples to verify (or qualify) observed effects.

Fourth-order polynomial fits were fitted to the data where appropriate. The general interpretation of these curves is provided in Figure II-14. The significance of any negative effects observed in this part of the analysis was then investigated using linear and/or nonlinear regression analysis. Significant adverse effects (when present) were confirmed by statistically significant positive regression coefficients on distance with either total taxa richness or dominant taxa abundance as the dependent variable.

Results for ACQ-B-Site

Observed water column copper concentrations as a function of time and distance from the ACQ-B treatment site are provided in Figure II-15. Water hardness, alkalinity, and DOC were low in all water samples examined from the Wildwood project area. The resulting chronic EPA copper criterion for water was $2.68 \mu\text{g Cu/L}$ and is included for reference in Figure II-15. Based on this analysis, adverse effects on sensitive species could be expected in the immediate vicinity of the structure for at least the initial 6 months.

Sediment levels of copper observed during this study are provided in Figure II-16. The TEC and the high NEC reported by Jones and others (1997) are provided for reference. The TEC was exceeded at distances between -0.5 m upcurrent and $+5.0 \text{ m}$ downcurrent in samples collected on days 162 and 336. This suggests that the most sensitive species might be affected under worst-case conditions. The high NEC was also exceeded at these times and distances. These levels also suggest that the most sensitive species would likely be affected under worst-case conditions. However, the most sensitive species (particularly genera within the order Ephemeroptera) were not a significant part of the Wildwood aquatic invertebrate community because of the naturally stressful character of the Wildwood wetland environment. Therefore the TEC and NEC are likely conservative benchmarks against which to assess potential effects in Wildwood sediments inhabited by a more robust community dominated by annelids, mollusks, and chironomids.

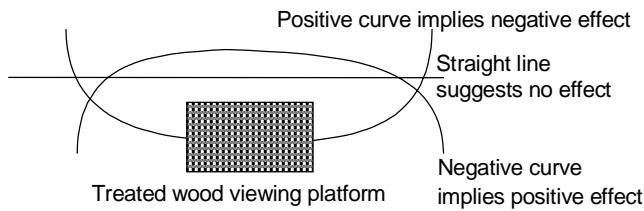

Figure II-14—General interpretation of fourth-order polynomial fits to data.

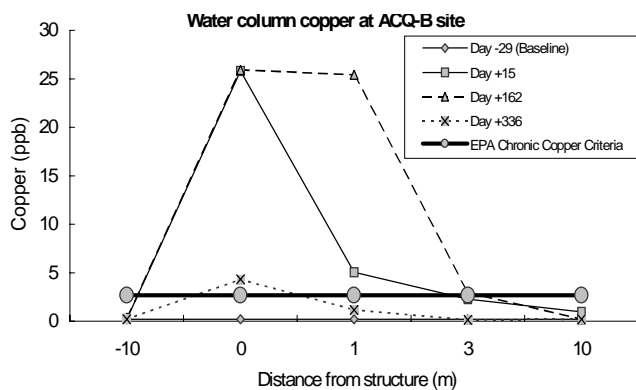

Figure II-15—Water column copper concentrations at ACQ-B site as function of time and distance from structure located at 0 m.

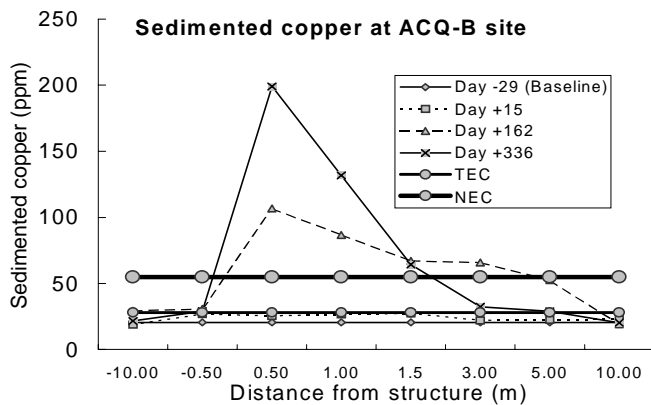

Figure II-16—Sedimented copper concentrations at ACQ-B site as function of time and distance from structure located at 0 m.

Invertebrate Response

Maximum dissolved copper concentrations were approximately 9 times higher than the EPA chronic criterion of 2.68 $\mu\text{g/L}$ at a hardness of 18.5 $\text{mg CaCO}_3/\text{L}$ on days +15 and +162 in proximity to the ACQ-B site. Aquatic invertebrates resident on the artificial substrates and on vegetation would be more exposed to dissolved copper than would infauna. The values for each metric evaluated on day +162 at the ACQ-B site are summarized in Figure II-17. Artificial substrate invertebrate data at the ACQ-B site were explored

using ANOVA. Differences between sample stations were not significant ($\alpha = 0.05$) during the baseline survey ($p = 0.37$) or on day +15 ($p = 0.313$). Significant differences in the means of all metrics, except Shannon's index, were observed in samples collected on day +162 when copper levels were still elevated. The results of post hoc testing using Duncan's test are provided for dominant taxa abundance and total taxa richness in Table II-25. Dominant taxa abundance was significantly higher at 3 and 10 m downcurrent when compared with either the 0.5-m station or the upstream control. Likewise, total taxa richness was significantly higher at stations located 3 and 10 m downstream when compared with the upstream control. These metrics were not significantly different at the 0.5-m station when compared with the upstream control.

Similar results were obtained for Pielou's index. These results do not support the hypothesis that the elevated copper levels, highest at the 0.5-m station, had caused adverse effects on the aquatic invertebrates that settled on artificial substrates because the evaluated metrics were not significantly different between the 0.5-m station and upstream controls. However, the results do suggest the possibility of a subtle effect.

Mean values for the endpoints evaluated in this study on day 162, when copper levels exceeded the EPA chronic criterion, are provided in Figure II-18 for vegetation samples. The relationships are similar to those observed on the artificial substrate samples and indicate that no significant adverse effects were documented in the invertebrate community associated with the area surveyed adjacent to the ACQ-B-treated structure. For both types of samples, stations located adjacent to and downstream from the structure held invertebrate communities that were as or more abundant and diverse than invertebrate communities found at the upstream control.

Sediment Effects

Sediment concentrations of copper remained low until day 162, when they exceeded the TEC and the high NEC described by Jones and others (1997) at distances from -0.5 to +5.0 m. Sediment levels increased in the immediate vicinity of the structure on day +336, but exceedances were restricted to the -0.5 to +1.5 m area; the peak concentration was 200 mg Cu/kg dry sediment at the +0.5-m sample station.

Effects associated with sedimented copper were expected to be found in the infauna collected with a Petite Ponar grab. Twelve single samples were collected at varying intervals up and downstream from the structure on each sampling day. The results of this infaunal analysis were analyzed using multiple regression. The data for day 336 when sedimented copper levels peaked are summarized in Figure II-19. A least-squares best fit is provided for each evaluated endpoint. Maximum dominant taxa abundance and total taxa richness were observed in the immediate vicinity of the ACQ-B-treated viewing platform and were decreased

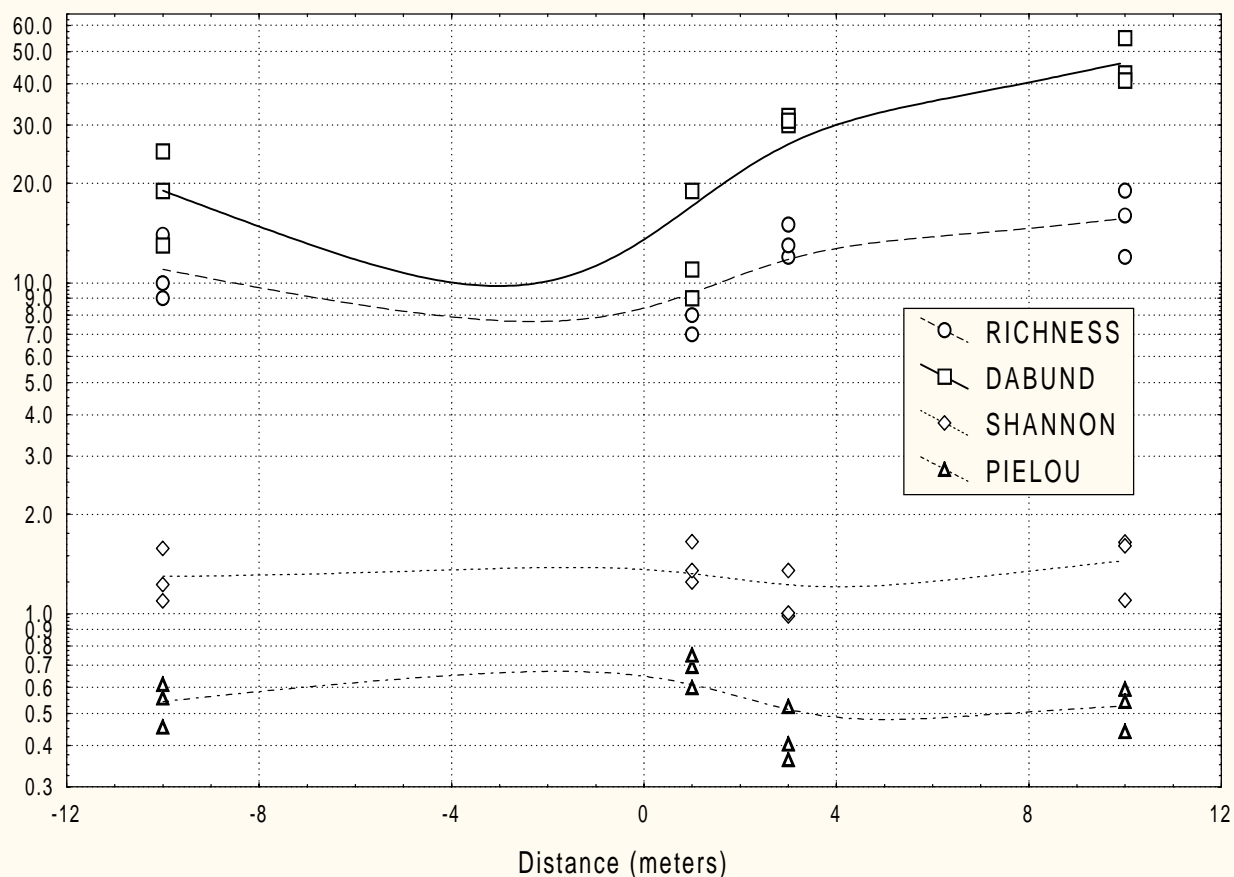

Figure II-17—Mean values for total invertebrate richness, dominant invertebrate abundance (DABUND), Shannon’s index, and Pielou’s index for aquatic invertebrates on three replicate artificial substrate collectors at each distance above and below ACQ-B-treated structure on day +162.

Table II-25—Summary of pairwise comparison of dominant taxa abundance and total taxa richness at varying distances from ACQ-B structure for mean artificial substrate values collected on day +162 post construction^a

Distance from structure	Probability of equal metrics at paired stations at various distances from ACQ-B structure							
	Dominant taxa abundance ^b for various mean artificial substrate values				Total invertebrate richness ^c for various mean artificial substrate values			
	-10 m	+0.5 m	+3.0 m	+10 m	-10 m	+0.5 m	+3.0 m	+10 m
	(74)	(35)	(154)	(176)	(11)	(8)	(13)	(16)
-10.0 m		0.2207	<u>0.0291</u>	<u>0.0005</u>		0.1615	0.2644	0.0502
+0.5 m	0.2207		<u>0.0051</u>	<u>0.0002</u>	0.1615		<u>0.0301</u>	<u>0.0061</u>
+3.0 m	<u>0.0291</u>	<u>0.0051</u>		<u>0.0096</u>	0.2644	<u>0.0301</u>		0.2644
10.0 m	<u>0.0047</u>	<u>0.0002</u>	<u>0.0096</u>		0.0502	<u>0.0061</u>	0.2644	

^aDuncan’s test. Dissolved copper levels peaked on day +162.

Significant differences are underlined.

^bNo individuals.

^cNo taxa.

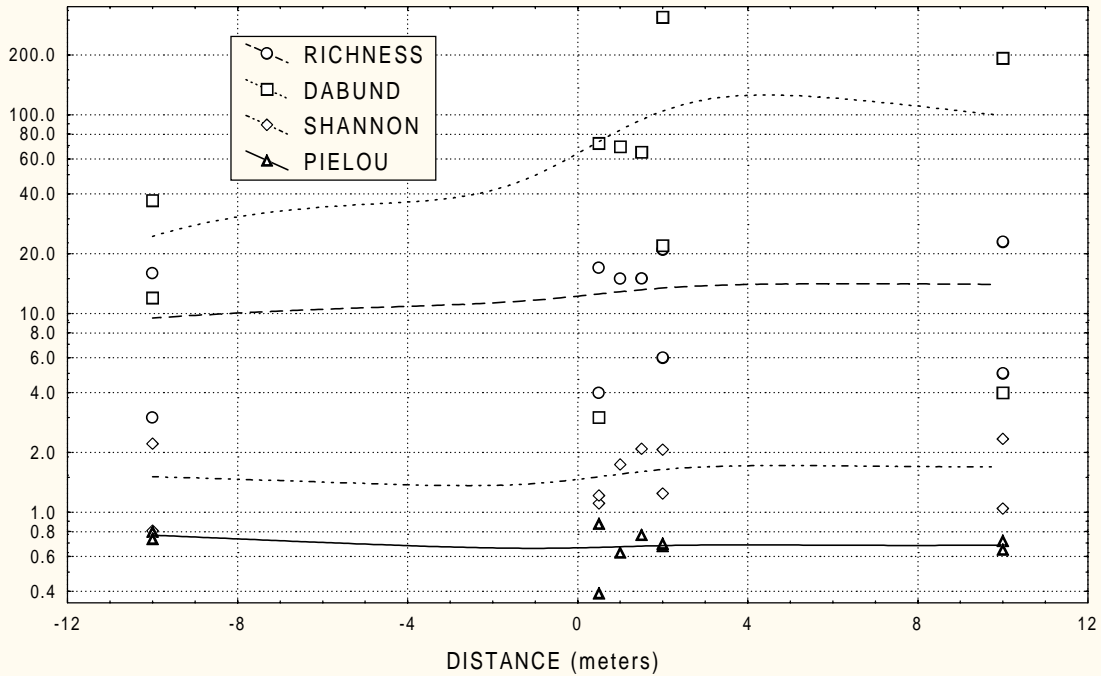

Figure II-18—Mean values for total invertebrate richness, dominant invertebrate abundance, and Shannon’s and Pielou’s indices for aquatic invertebrates collected from vegetation at each of four distances above and below ACQ-B-treated structure on day +162.

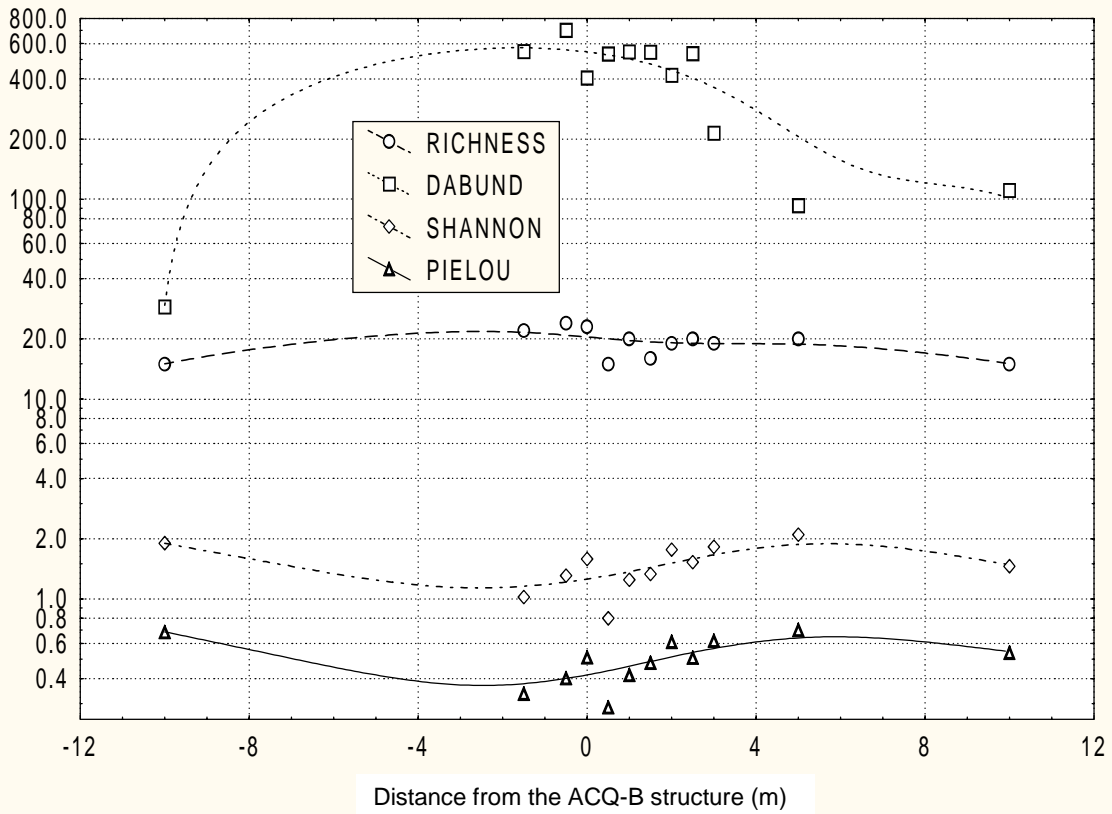

Figure II-19—Total taxa richness, dominant taxa abundance, and Shannon’s and Pielou’s indices for infauna collected at ACQ-B site on day +336.

up- and downstream. Both Shannon's index and Pielou's evenness index suggested slight negative effects in the immediate vicinity of the platform.

The scale of the abscissa on which these indices are plotted is expanded in Figure II–20. These indices are related and are expected to co-vary. The significance of the trend observed in Figure II–20 was investigated using linear regression analysis on data at distances from –1.5 to +5.0 m. The resulting regression was significant ($p < 0.007$) and explained 57% of the variation in the database. A significant ($p = 0.007$) coefficient of +0.16 on the independent variable of distance was obtained with a small standard error of 0.045. This relationship is shown on Figure II–20. This analysis suggests a significant increase in Shannon's index with distance from the platform.

To investigate the relationship between concentration of sedimented copper and observed changes in Shannon's index, the independent variable of distance was replaced with sedimented copper concentration (SEDCU). The regression explained only 7% of the variation in the data and was not significant ($p < 0.45$). The intercept (constant) was significant ($p = 0.000$) and equaled 1.55, the mean value for Shannon's index across all observed copper concentrations in the evaluated area. The coefficient on sedimented copper was essentially zero (0.0014) and was not significant ($p = 0.45$). Therefore, it appears that the significant downstream increase observed in Shannon's index for infaunal invertebrates on day +336 was not associated with sedimented copper but with some other factor. When coupled with the observed increases in dominant taxa abundance and total taxa richness observed in the immediate vicinity of the structure, these observations suggest that copper was not responsible for the observed cline in Shannon's index observed in the vicinity of the structure at the end of the study.

Summary of Biological Effects at the ACQ–B Site

The biological assessment for the ACQ–B treatment site was summarized using the Varimax normalized factor analysis with a principal factors (MINRES) extraction (Fig. II–21). The two factors presented in Figure II–21 explain 32% of the variation.

A scree plot indicated that additional factors added minimally to the explained variation. This suggests that the observed variation is associated with factors not included in the database. In Figure II–21, total taxa abundance and dominant taxa abundance were principally dependent on the abundance of chironomids in the genera *Eukiefferiella* (AEUKS) and *Tanytarsus* (AITYS). The only other significant loading was for Pielou's index, which was negative. This suggests that evenness was adversely effected by the abundance of *Eukiefferiella* and *Tanytarsus*, which tended to dominate at this site. The isopod *Caecidotea* (ACCS) and the mayfly *Paraleptophlebia* (AIPAR) were significantly loaded on factor 2.

Although sediment and water copper concentrations (SEDCU and WCU, respectively) are found at the bottom of Figure II–21, they are not significantly loaded. The positive association of SEDCU with date and the negative association of WCU with date reflects the long-term increases in sedimented copper and the short-term spike followed by a longer term decline in dissolved copper.

Statistically significant adverse effects were not documented for any of the metrics evaluated at the ACQ–B site. However, Figure II–21 shows possible subtle effects. Most dominant taxa are not distant from sedimented or dissolved copper concentrations, suggesting at least moderate tolerance. The most distant taxa (those most likely adversely affected by dissolved and/or sedimented copper) include mayflies of the genus *Paraleptophlebia* (AIPAR), isopods of the genus *Caecidotea* (ACCS), stoneflies of the genus *Amphinemura*, and mollusks of the genus *Gyraulus*. Total taxa richness (RICHNESS) and Shannon's index (SHANNON) are also fairly distant from either measure of copper. Other taxa show little adverse reaction to copper. However, it is interesting that more taxa are slightly further from WCU than from SEDCU. This was expected because of the reduced toxicity likely associated with copper bound in sediments or detoxified by humic acid precipitation. Chironomids of the genus *Tanytarsus* have previously been identified as copper sensitive, albeit at concentrations higher than those observed in this study. At the ACQ–B site, these midges were among the least sensitive. However, they were more sensitive to dissolved copper than to sedimented copper. This was unexpected because for the entire study, more of these midges were found in sediments than were found on vegetation or artificial substrates, where they would be more exposed to dissolved copper.

Despite elevated dissolved copper concentrations adjacent to the ACQ–B structure, there is no evidence in this analysis leading to a rejection of the null hypothesis that the metrics evaluated at the closest station, or those further downstream, were lower than those observed at the upstream control. As previously discussed, the likely reason is that the very slow currents at these sites have created a depositional environment that hosts a robust community of organisms that are tolerant to many natural and anthropogenic insults. This hypothesis is supported by the factor analysis presented in Figure II–21. The most sensitive species, upon which the EPA chronic copper standard was developed, are generally found in erosional, lotic environments. Copper lost from treated wood structures into those lotic environments would be diluted rapidly. Whether or not the resulting concentrations would create adverse effects in sensitive species is problematic. This environment was chosen because it represents a worst case with respect to the accumulation of copper in the near field. The robustness of the indigenous invertebrate community is intuitive as an afterthought but it was not anticipated in the experimental design.

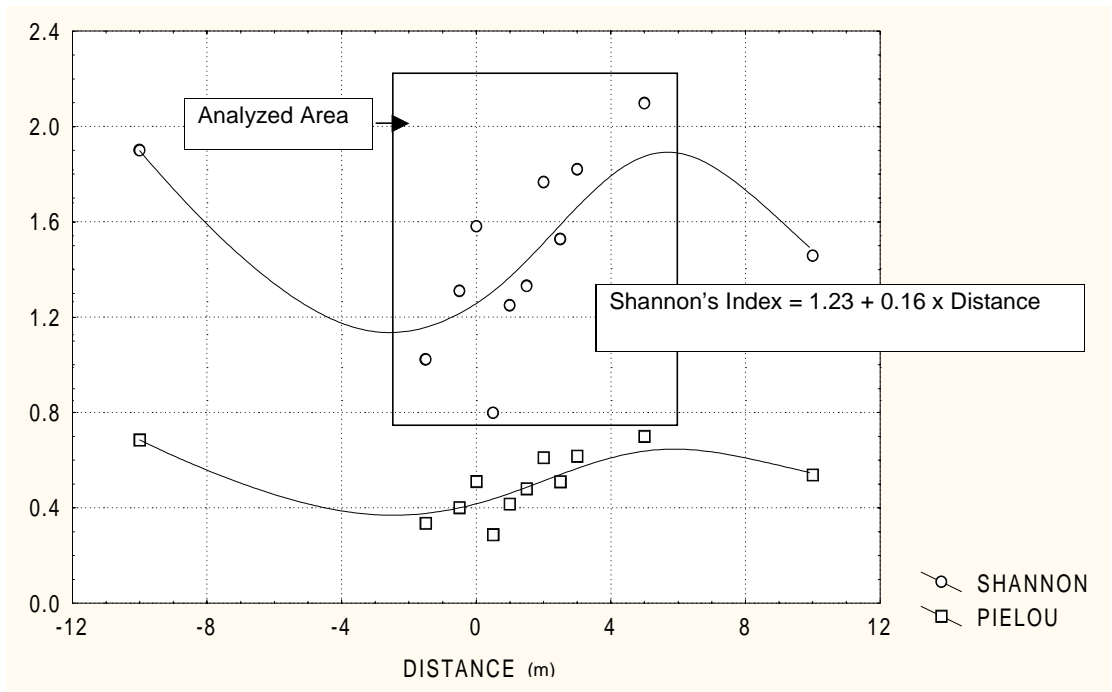

Figure II-20—Shannon's and Pielou's indices for infauna data collected at ACQ-B site on day +336. Area subjected to regression analysis is blocked; resulting significant regression is given.

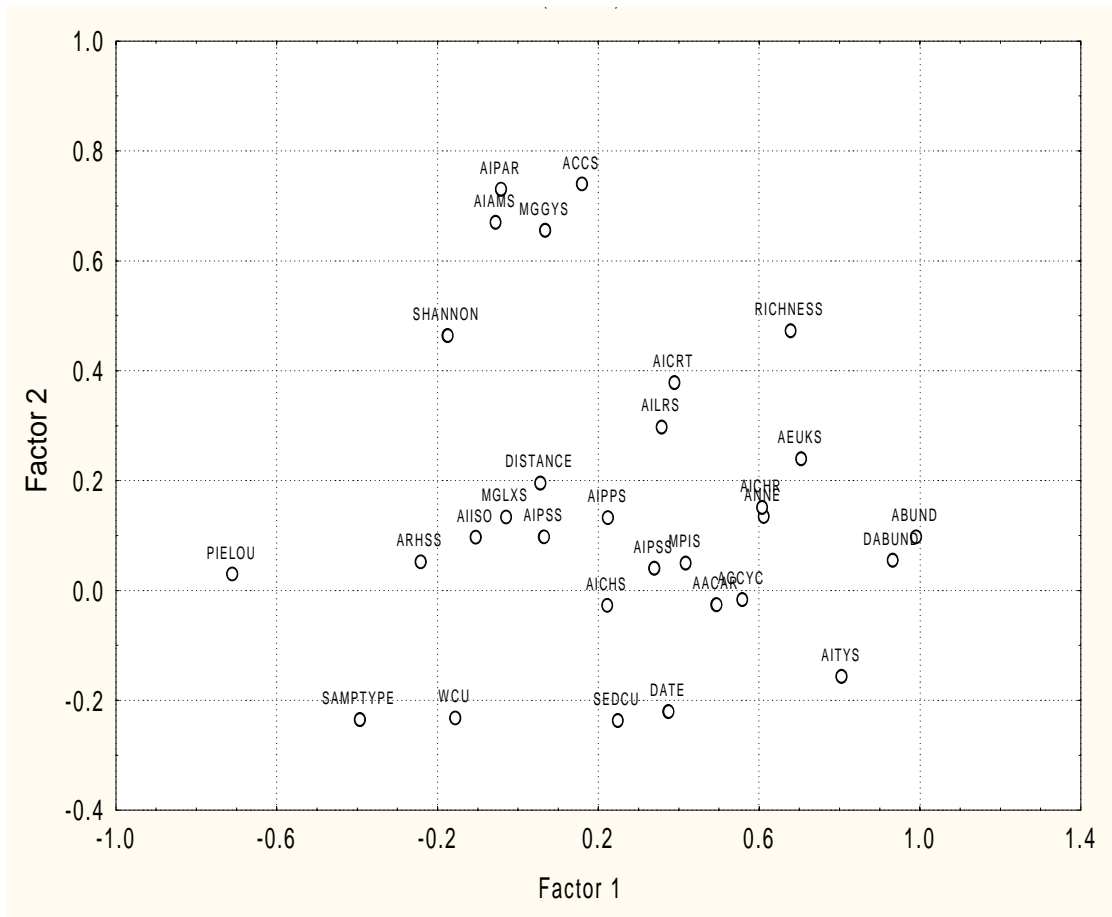

Figure II-21—Results of factor analysis on all invertebrate data collected at ACQ-B site. Principal factors (MINRES) extraction followed by Varimax normalization. See Appendix for designation of variables.

Results for ACZA Site

Water column concentrations of copper observed at the ACZA site are described as a function of time and distance from the structure in Figure II-22. The EPA chronic copper criterion for this site is provided for reference. The value of 2.68 µg/L was significantly exceeded in the vicinity of the platform (0 to +1.0 m) on day +15 when the concentration reached 100 µg/L. Copper levels at all other times and distances were less than the criterion. This part of the analysis focused on the invertebrate community response to dissolved copper observed on day +15 when adverse effects were anticipated.

Sediment levels of arsenic, copper, and zinc observed at the ACZA site are described in Figures II-23 to II-25. The TEC and high NECs of Jones and others (1997) are provided for reference. There was a slight exceedance of the TEC on day 15 at the + 3.0-m downstream station. With that exception, sedimented metals at the ACZA site were consistently less than the TEC and no effects on infauna were anticipated.

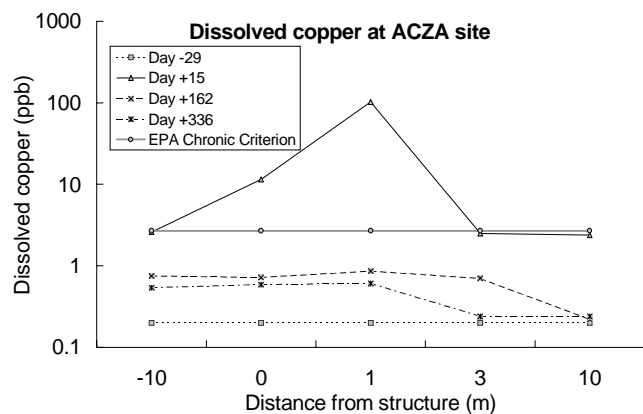

Figure II-22—Water column copper concentrations at ACZA site as function of date and distance up and downstream from structure centered at 0 m.

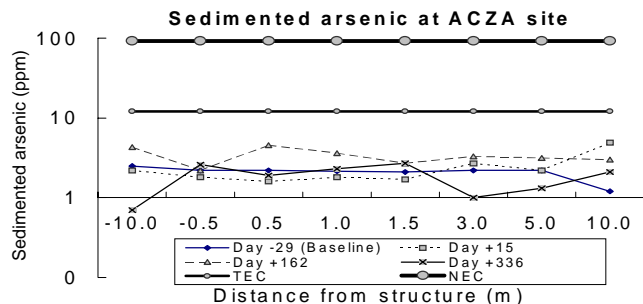

Figure II-23—Sediment concentrations of arsenic at ACZA site as function of time and distance from structure located at 0 m. Threshold effects level (TEC) and high no-effect concentration (NEC) of Jones and others (1997) provided for reference.

Invertebrate Response

Significantly elevated copper was measured on day +15 in the immediate vicinity of the ACZA structure. The observed values exceeded the EPA chronic criterion by factors of 3.7 to 38 with a steep gradient to background levels at stations further upstream and/or downstream. The distinct boundaries of the copper exceedance observed in Figure II-22 are consistent with the lack of observable currents in the area. Effects on aquatic invertebrates associated with these high concentrations would most likely be seen in either the artificial substrate or vegetation samples where invertebrates were most exposed to dissolved copper in the water column. In addition, if sensitive taxa were present, significant decreases in those taxa should have been observed at the +0.5 m station and perhaps at the +3.0 m station, but not at the upstream control (-10 m) or +10 m downstream station. Adverse effects associated with dissolved or sedimented copper were not anticipated on any other day in this study at the ACZA treatment site.

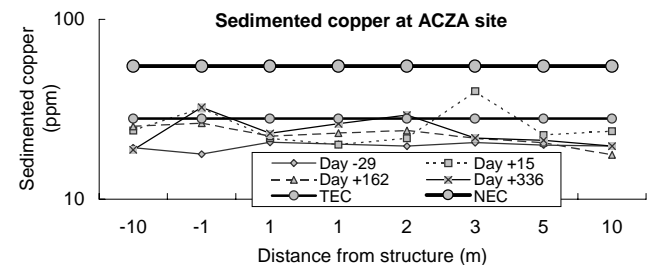

Figure II-24—Sediment concentrations of copper at ACZA site as function of time and distance from structure located at 0 m. TEC and high NEC (Jones and others 1997) provided for reference.

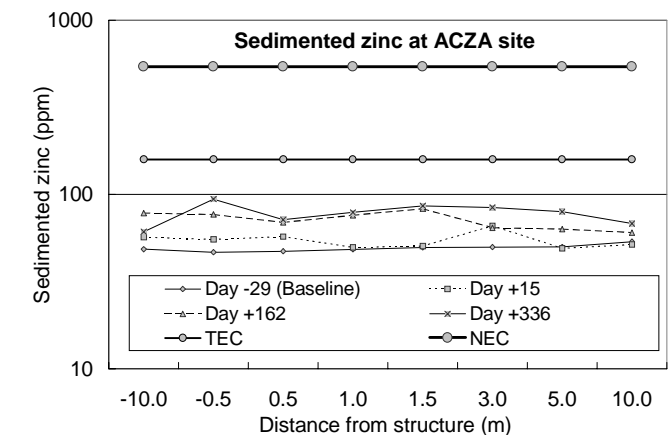

Figure II-25—Sediment concentrations of zinc at ACZA site as function of time and distance from structure located at 0 m. TEC and high NEC (Jones and others 1997) provided for reference.

Mean values for total taxa richness, dominant taxa abundance, and Shannon's and Pielou's indices are provided in Figure II-26 as a function of distance from the ACZA structure on day +15 for artificial substrate samples. The null hypothesis that these endpoints were equal at each sample station was not rejected at $\alpha = 0.05$ using ANOVA ($p = 0.105$). A post hoc Duncan's test indicated that taxa richness and dominant taxa abundance were not significantly different at any station. Shannon's index was significantly lower at the upstream control when compared with either the 3- or 10-m downstream stations. Pielou's evenness index was significantly less ($\alpha = 0.05$) at the upstream control when compared with the +3.0-m downstream station. No statistically significant reductions in any of the tested endpoints were observed in association with peak concentrations of copper observed at the ACZA site on day +15.

Vegetation Samples

The metrics evaluated in this study are displayed in Figure II-27 for invertebrates collected from vegetation on day +15 at the ACZA treatment site. The data indicate significant declines in all the metrics, from highest values at the closest (0.5-m) station to much lower values at the +2.0-m station. Copper levels at these two stations were essentially the same (57.0 $\mu\text{g/L}$ at 0.5 m and 52.5 $\mu\text{g/L}$ at 2.0 m).

In contrast to dominant taxa abundance, total taxa abundance was higher at the 2.0-m station when compared with that at the 0.5-m station. Table II-26 provides an inventory of all taxa collected from vegetation on day +15 at these stations downstream from the ACZA site. The annelid *Limnodrilus* sp., which was previously been shown to be rather insensitive to copper, dominated the invertebrate community on vegetation (and in underlying sediments) at a distance of 2.0 m. *Limnodrilus* sp., the bivalve mollusk *Pisidium* sp., and the chironomid *Larsia* sp. dominated at 0.5 m. None of these species was identified as copper intolerant in the database summarized in Table II-21. The lack of replication for vegetation samples did not permit a test of the significance of the reductions observed at the 2.0-m downstream station. Dissolved copper concentrations observed on day +15, when these samples were collected, were equally elevated at both the 2.0- and 0.5-m stations. Coupled with the lack of observed differences from the replicated Hester-Dendy artificial substrate samples examined on this same date, the weight of evidence suggests that the differences observed on vegetation are simply a result of random sampling and not associated with copper. This finding is supported by the observation that maximum scores for each metric were found at the closest station (0.5-m) where copper levels were highest. A similar pattern was not observed on day +162 or +336 at the ACZA site.

Sediment Effects

Sediment concentrations of arsenic and zinc adjacent to the ACZA structure remained at or below the TEC reported by Jones and others (1997) and no adverse effects were anticipated in association with these metals. Copper concentrations exceeded the TEL, but not the NEC, on days +15 and +336.

Effects associated with sedimented metals would most likely be found in the infauna collected with the Petite Ponar grab. Twelve single samples were collected at various intervals up- and downstream from the ACZA structure on each sampling day. The results of the infaunal analysis were analyzed using multiple regression. Figure II-28 summarizes the data for day +15 when copper levels slightly exceeded the TEC at the 3.0-m station, and Figure II-29 summarizes the endpoints for day +336. No adverse effects were evident on day +15. There was an apparent decrease in the abundance of dominant infauna between the -0.5-m and +5.0-m stations. The significance of this response was tested using regression analysis. A significant ($\alpha = 0.05$) positive coefficient on the dependent variable distance would substantiate the apparent increase in dominant taxa abundance between these distances. Regression analysis revealed a significant intercept ($p = 0.002$), but the coefficient on distance was not significant ($p = 0.13$). A second analysis was completed with sedimented copper as the independent variable; the coefficient on sedimented copper was negative (-8.68) but not significant ($p = 0.145$). Based on this analysis, the null hypotheses that the abundance of dominant infauna was equal at varying distances was not rejected and any effects associated with either sedimented copper or distance from the structure were judged to not be significant at $\alpha = 0.05$.

Summary of Biological Effects at the ACZA Site

The biological effects observed at the ACZA site are summarized in Figure II-30. Sedimented levels of zinc, copper, and arsenic, along with copper dissolved in the water column are grouped tightly, indicating their positive correlation. However, none of the metals was significantly loaded on factor 1 or 2. Their proximity to the variable distance reflects, in part, the restricted distribution of metals to the immediate vicinity of the structure. Abundance of the chironomid *Psectrotanyptus* sp. (AIPSS) and the mollusk *Pisidium* sp. (MPIS) was directly correlated with sedimented metal. All other species were inversely correlated. The stonefly *Amphimura* sp. (AIAMS), the chironomid *Rheosmittia* sp. (ARHSS), *Chironomus* sp. (AICHS), and midges (AICHR), which are grouped in the Family Chironomidae, had the most negative correlations with metal concentrations. However, the correlations were not significant; the absolute value of all negative correlation coefficients was less than 0.27. Also note that total taxa richness appeared to be one of the more sensitive (but not statistically significant) indicators of stress associated with metals.

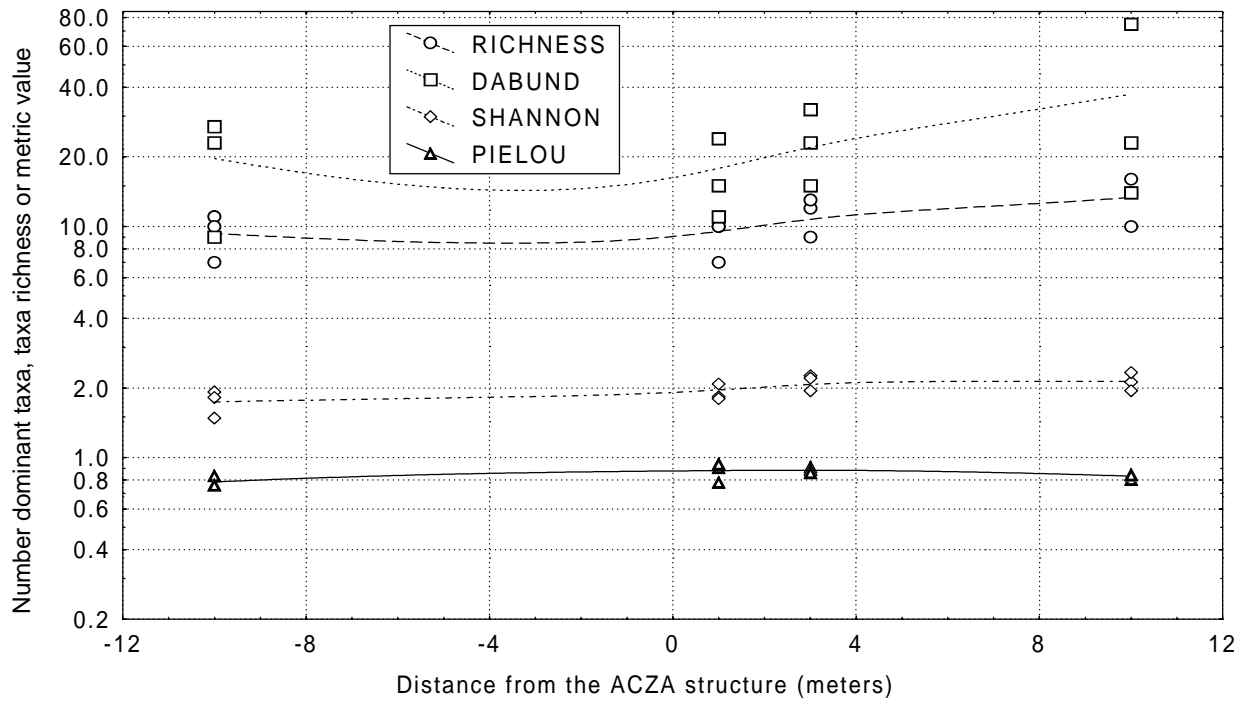

Figure II-26—Total taxa richness, dominant taxa abundance, and Shannon’s and Pielou’s indices for invertebrates collected from artificial substrates at ACZA site on day +15. Distance-weighted least-squares regression lines are provided for each endpoint.

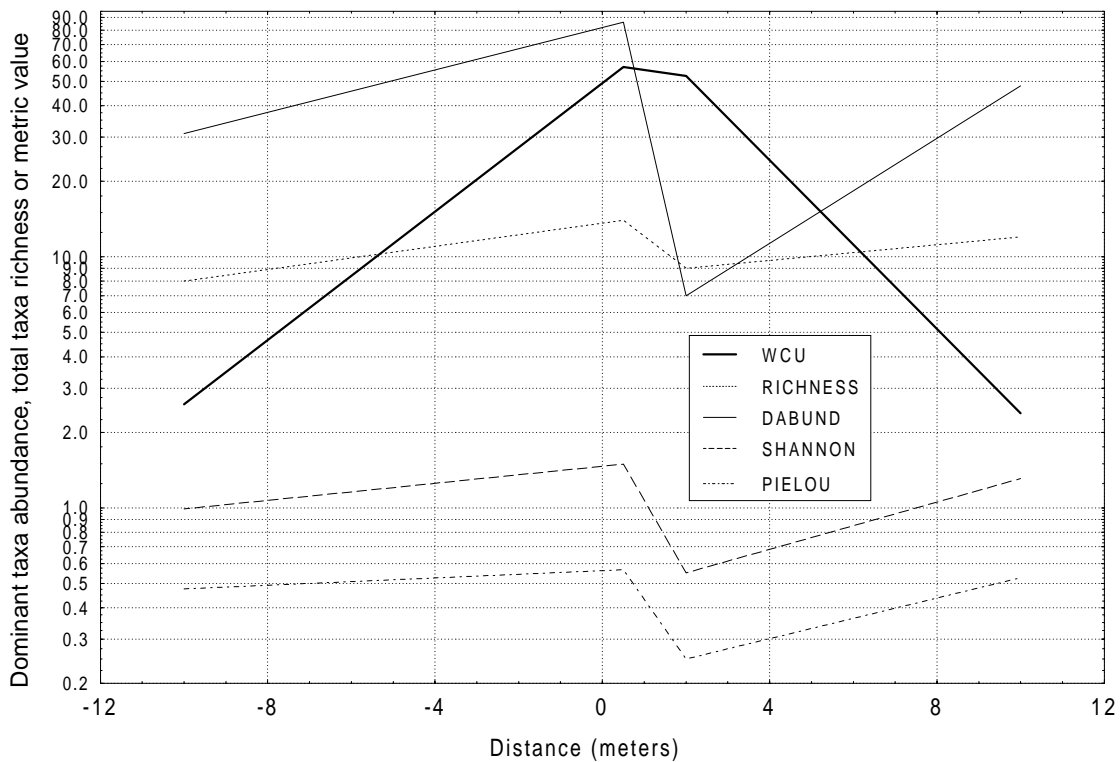

Figure II-27—Total taxa richness, dominant taxa abundance, and Shannon’s and Pielou’s indices for invertebrates collected from artificial substrates at ACZA site on day +15. Observed concentrations of dissolved copper (WCU) are included for reference.

Table II–26—Inventory of invertebrates collected from vegetation and sediments downstream from ACZA treatment site on day +15 when observed dissolved copper levels peaked^a

Taxon	Invertebrates (no.)	
	Vegetation at 0.5 m	Vegetation at 2.0 m
Nematoda	1	1
<i>Limnodrilus</i> sp.	28	129
<i>Lanx</i> sp.	1	0
<i>Pisidium</i> sp.	61	6
Acarina	0	1
Cyclopoida	3	0
<i>Hyallela</i> sp.	0	2
Isotomidae	1	0
<i>Baetis</i> sp.	1	1
<i>Sialis</i> sp.	2	0
<i>Haliphus</i> sp.	1	0
<i>Donacia</i> sp.	0	2
Chironomidae	1	0
Tanypodinae	0	2
<i>Larsia</i> sp.	15	0
<i>Psectrotanypus</i> sp.	2	0
<i>Tanytarsus</i> sp.	1	0
<i>Eukiefferiella</i> sp.	1	0
Dolichopodidae	0	1
Total taxa richness	14	9
Total taxa abundance	119	145

^aSpecimens collected in 20-cm-diameter stovepipe.

Dominant and total taxa abundance are significantly loaded on factor 1 along with *Limnodrilus* sp. and the chironomid *Larsia* sp.—species whose individual abundance had a significant effect on either metric. Pielou’s and Shannon’s indices were reduced by the increased abundance of the dominant species (right side of Fig. II–30). There did not appear to be any evidence of significant adverse effects on aquatic invertebrates associated with either distance or metal concentrations at the ACZA site. This is consistent with the low levels of metals found in sediments and in the water column on all sample dates except day +15, when elevated concentrations of dissolved copper were observed in close proximity to the structure. The lack of response on that day is likely associated with the robustness of the invertebrate community found in slow-moving water with fine grain sediments, which characterizes the Wildwood wetland.

Results for CCA–C Site

Water column concentrations of copper did not exceed the EPA chronic copper criteria of 2.68 µg Cu/L for a hardness of 18.5 mg CaCO₃/L on invertebrate sampling days following

construction (Fig. II–31). A maximum concentration of 1.55 µg/L was observed on day +162. This value is just greater than half the EPA quality criterion. Because more copper was anticipated to be released from the immersed treated wood on day +15, the analysis focused on that day. However, no adverse effects were anticipated at this low copper concentration.

Sedimented arsenic slowly increased after construction of the boardwalk and exceeded the TEC of Jones and others (1997) beginning on day 15. Observed arsenic levels did not exceed the high NEC at any time during the study (Fig. II–32). On day +15, an increase in arsenic was observed in the immediate vicinity of the structure (–1.5 to +5.0 m). By day +336, arsenic levels immediately around the structure had returned to near-background levels and increased arsenic was observed downstream (+3 to +10 m), suggesting reduced arsenic loss from the structure with time and sediment transport of the initial arsenic load. As Figure II–32 indicates, a similar result was obtained for sedimented copper with exceedances of the TEC of Jones and others (1997) beginning on day +15 and moving downstream on days +162 and +336. Based on the temporal distribution of these small increases in sedimented copper, we hypothesized that they were associated with construction of the boardwalk. Sedimented levels of copper (Fig. II–33) were less than the high NEC of Jones and others (1997) and no adverse effects were anticipated in association with the observed levels of either metal.

Observed levels of chromium in sediments adjacent to the CCA–C structure are provided in Figure II–34. Increases in chromium were small and accumulations remained well below the TEC level of Jones and others (1997). Sedimented chromium was not considered as a factor in investigating potential effects on infauna.

Invertebrate Response to Dissolved Copper

Adverse effects on aquatic invertebrates associated with the boardwalk were investigated in the water column by examining the replicated artificial substrate samples and single vegetation samples collected on day +15. Infaunal response to sedimented copper and arsenic was evaluated using regression analysis on data derived from Petite Ponar grab samples.

Decreases in total taxa richness, dominant taxa abundance, Shannon’s index, or Pielou’s evenness index are not apparent in the distance-weighted least-squares lines provided in Figure II–35 for data derived from artificial substrate or vegetation samples. The ANOVA did not reveal significant differences between the values of each metric describing the community on artificial substrates as a function of distance ($p = 0.116$). Consistent with the low levels of copper in the water column at the CCA–C site, no adverse effects on the community of invertebrates settling on artificial substrates were indicated in this analysis.

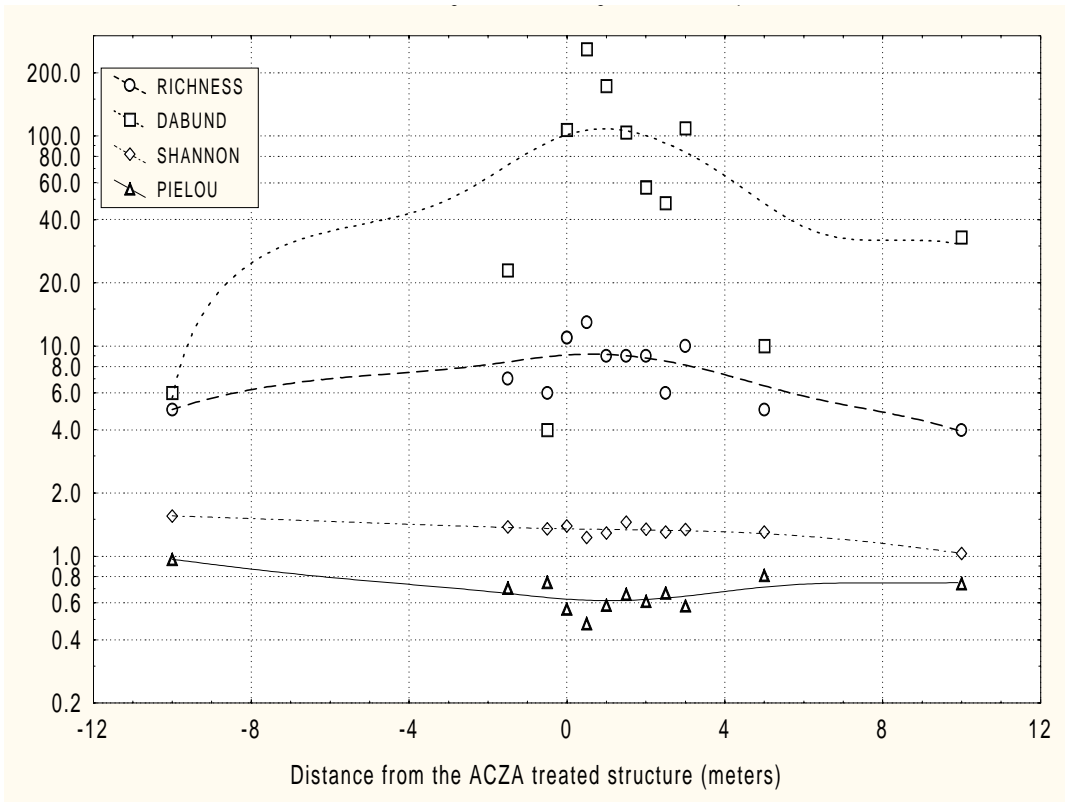

Figure II-28—Summary of total taxa richness, dominant species abundance, and Shannon’s and Pielou’s indices for infaunal samples collected on day +15 at ACZA site.

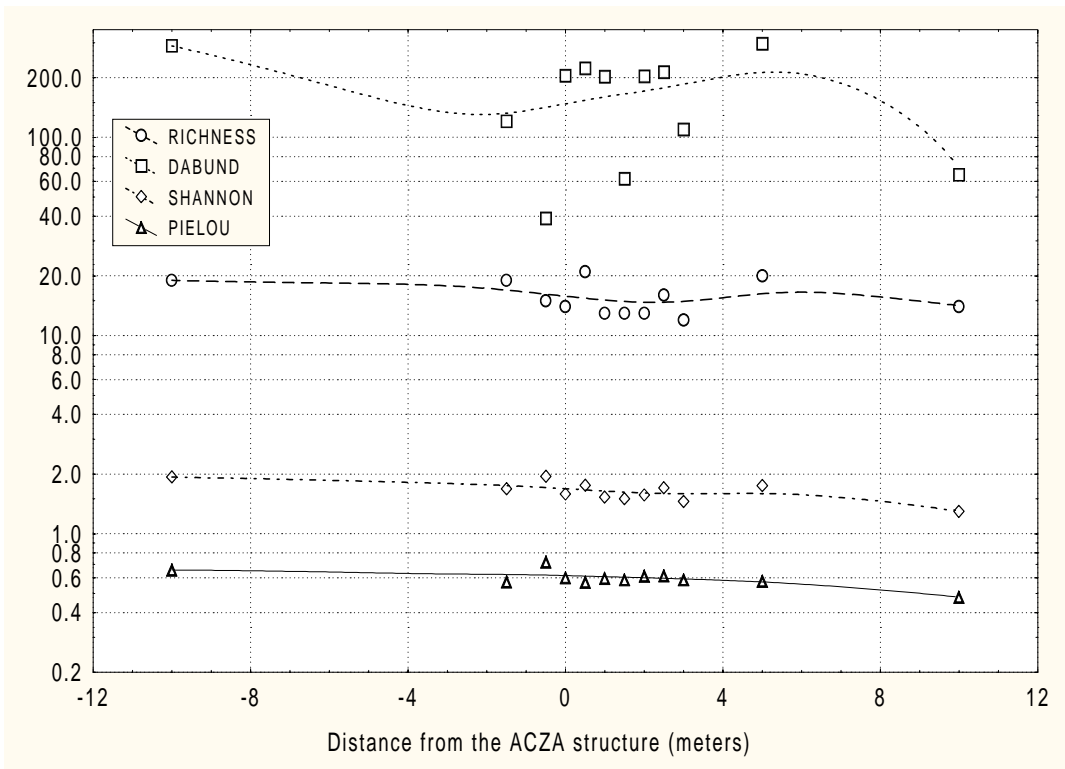

Figure II-29—Summary of total taxa richness, dominant species abundance, and Shannon’s and Pielou’s indices for infaunal samples collected on day +336 at ACZA site.

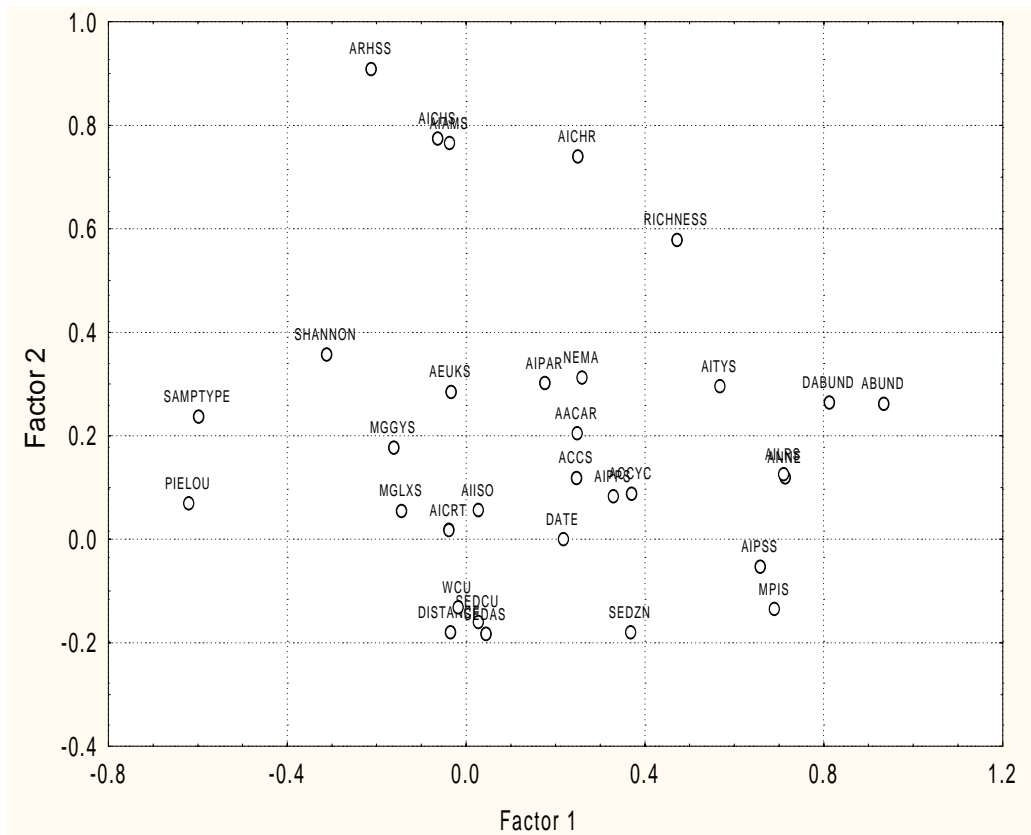

Figure II-30—Results of factor analysis on all invertebrate data collected at ACZA site. MINRES extraction followed by Varimax normalization. See Appendix for designation of variables.

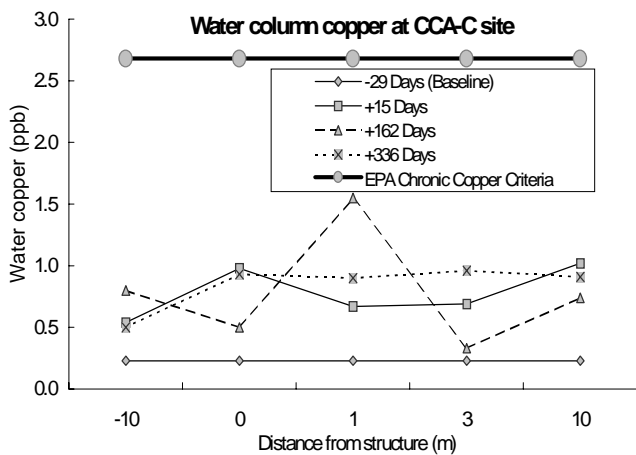

Figure II-31—Water column copper concentrations at CCA-C site as function of time and distance from structure located at 0 m.

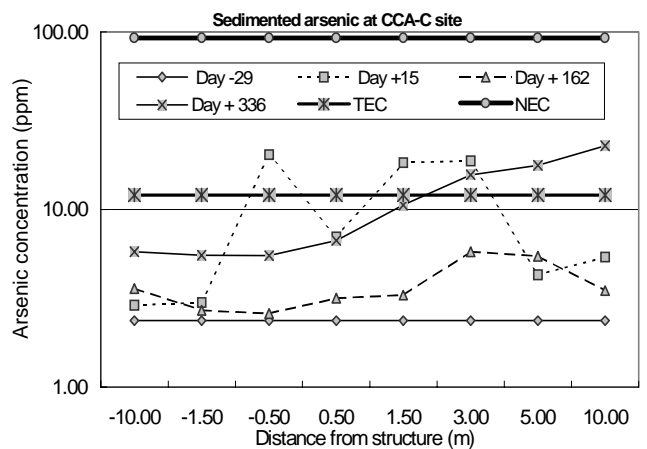

Figure II-32—Sediment arsenic concentrations at CCA-C site as function of time and distance from structure located at 0 m. TEC and NEC values provided for reference (Jones and others 1997).

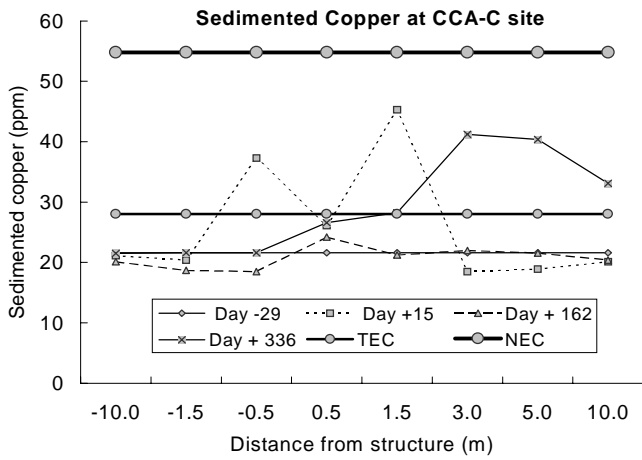

Figure II-33—Sediment copper concentrations at CCA-C site as function of time and distance from structure located at 0 m. TEC and NEC values provided for reference.

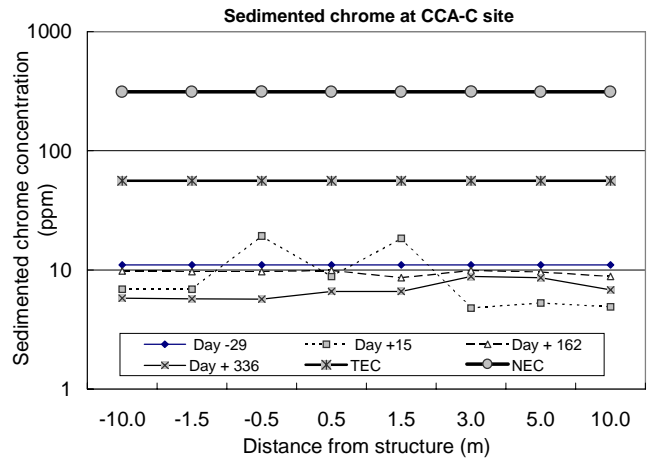

Figure II-34—Sediment chromium concentrations at CCA-C site as function of time and distance from structure located at 0 m. TEC and NEC values provided for reference.

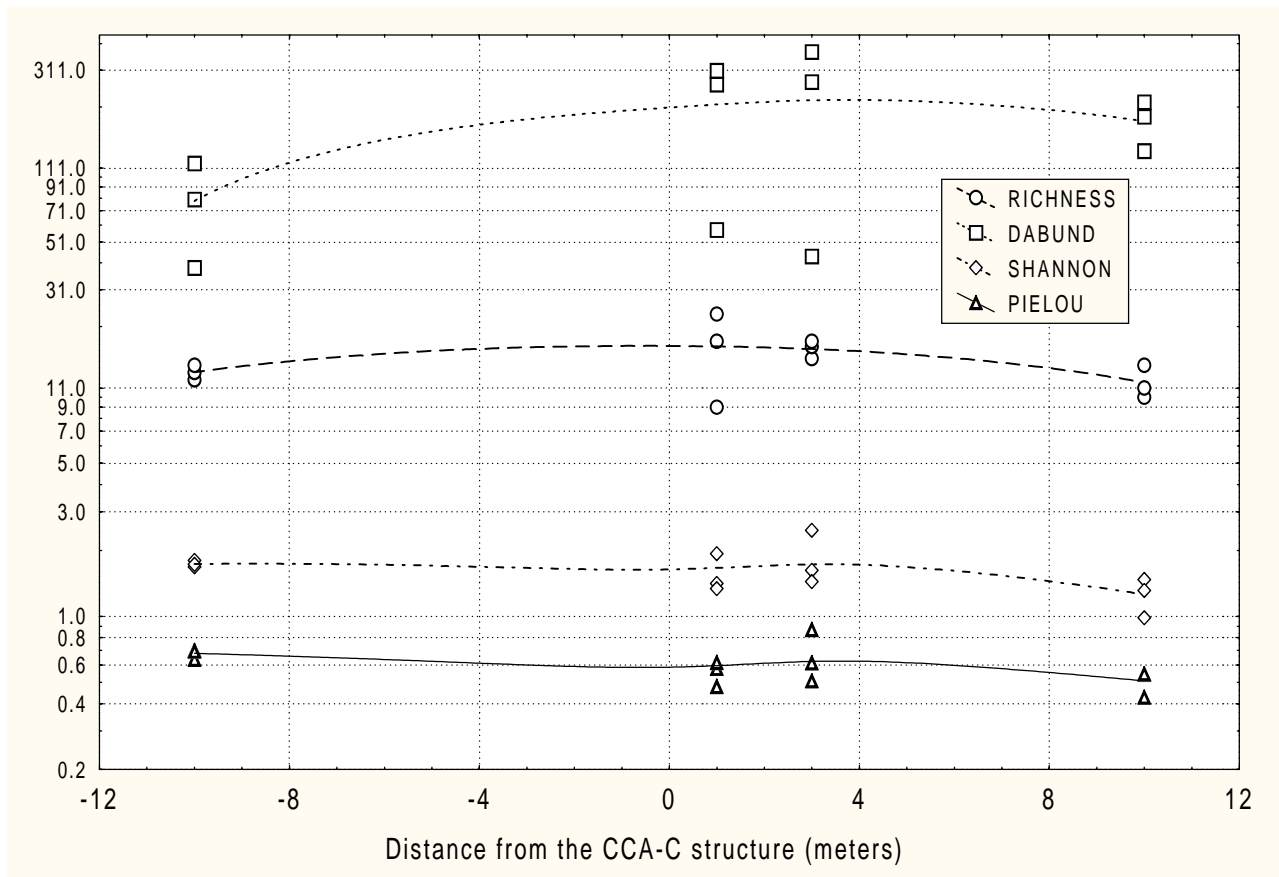

Figure II-35—Summary of total taxa richness, dominant species abundance, and Shannon's and Pielou's indices for artificial substrate samples collected on day +15 at CCA-C site.

Figure II-36 summarizes the metrics evaluated in this study when applied to the invertebrate community collected from vegetation on day +15 at the CCA-C site. Total taxa richness and dominant species abundance increased in the vicinity of the structure, suggesting no adverse effect. Small decreases were observed in Shannon's and Pielou's indices at and downstream from the structure. The lack of replication and few data points complicate determination of the significance of these small differences in the invertebrate community found on vegetation.

Invertebrate Response to Sedimented Copper and Arsenic

Elevated concentrations of arsenic and copper were observed from approximately 0.50 m upstream to >3.08 m downstream from the CCA-C structure. Arsenic levels were at or exceeded the TEC at each downstream station, but they did not exceed the high NEC of 92.6 mg As/kg dry sediment at any station. Sedimented copper concentrations exceeded the TEC within this same range and exceeded the high NEC at the 0-m station.

Effects associated with sedimented arsenic and copper would most likely be found in the infauna collected with a Petite

Ponar grab. Twelve single samples were collected at various intervals up- and downstream from the structure on each sampling day. The results of this infaunal analysis were analyzed using multiple regression. Figures II-37 and II-38 summarize the metrics evaluated in this study for days +162 and +336, respectively, when elevated arsenic and copper were observed in proximity to the structure. Total richness and dominant taxa abundance increased in the vicinity of the structure when compared with these metrics at the upstream control. Statistically significant trends were not apparent in either Shannon's or Pielou's index.

Pielou's and Shannon's indices increased from up- to downstream stations, indicating an increasingly more balanced community on day +336. However, the regression coefficient on distance was not significant and the slope of this line is therefore not significantly different from zero. Based on this evidence, the null hypothesis that each of these indices was equal at all stations cannot be rejected. The abundance of dominant infaunal taxa at the CCA-C treatment site on day +336 was highly variable, ranging from 68 at the 1.0-m station to 1,441 at the 3.0-m station. Total taxa richness was also variable; 16 species were found at the 1.0-m station and 46 at the 3.0-m station. The significance of the apparent trend in dominant taxa abundance was investigated using

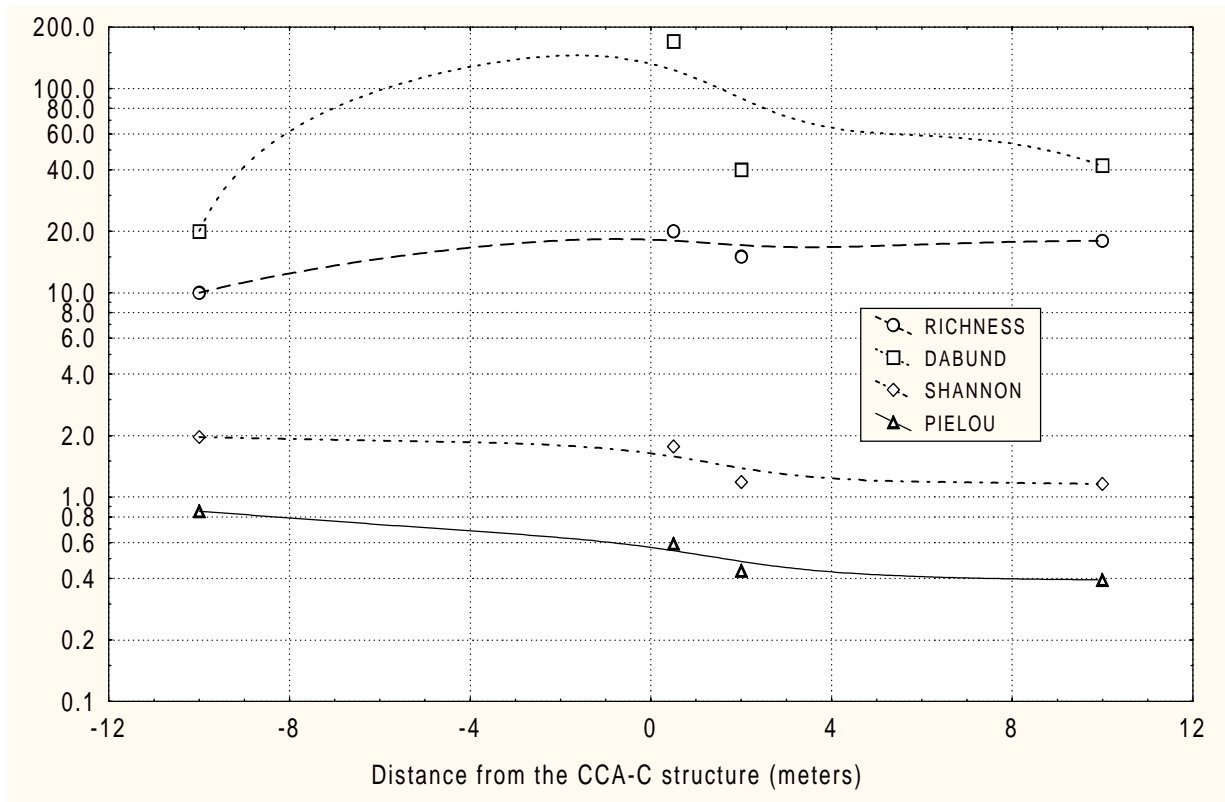

Figure II-36.—Summary of total taxa richness, dominant species abundance, Shannon's index, and Pielou's index for vegetation samples collected on day +15 at CCA-C site.

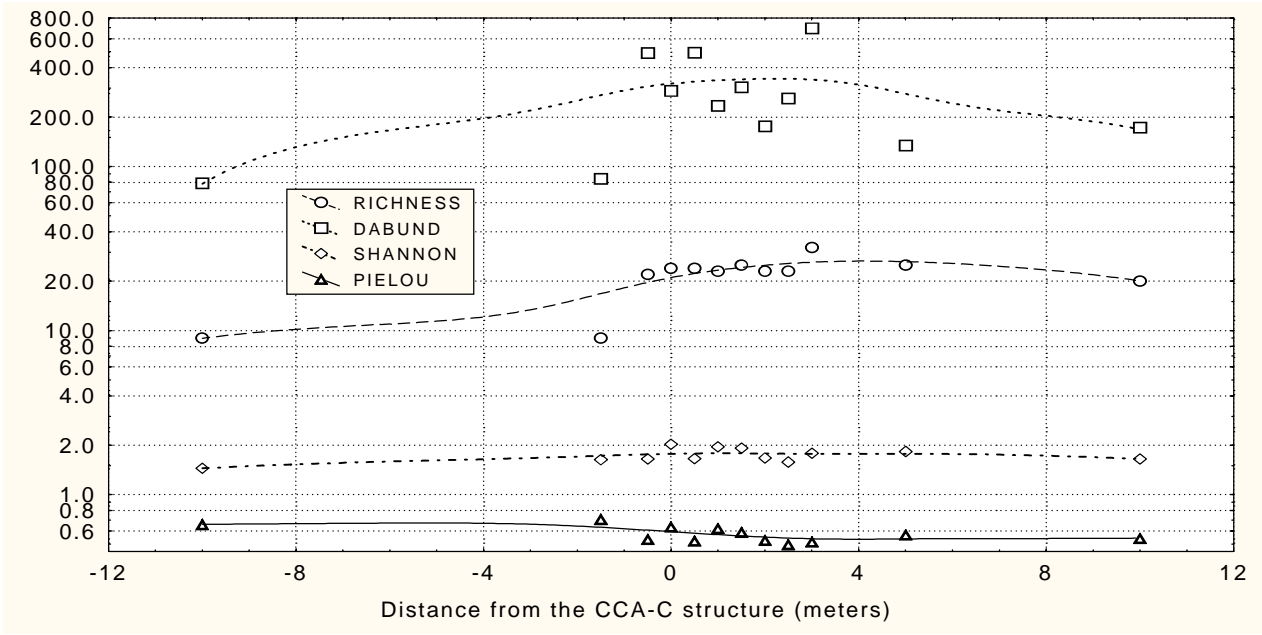

Figure II-37—Summary of total taxa richness, dominant species abundance, Shannon’s index, and Pielou’s index for infaunal samples collected on day +162 at CCA-C site.

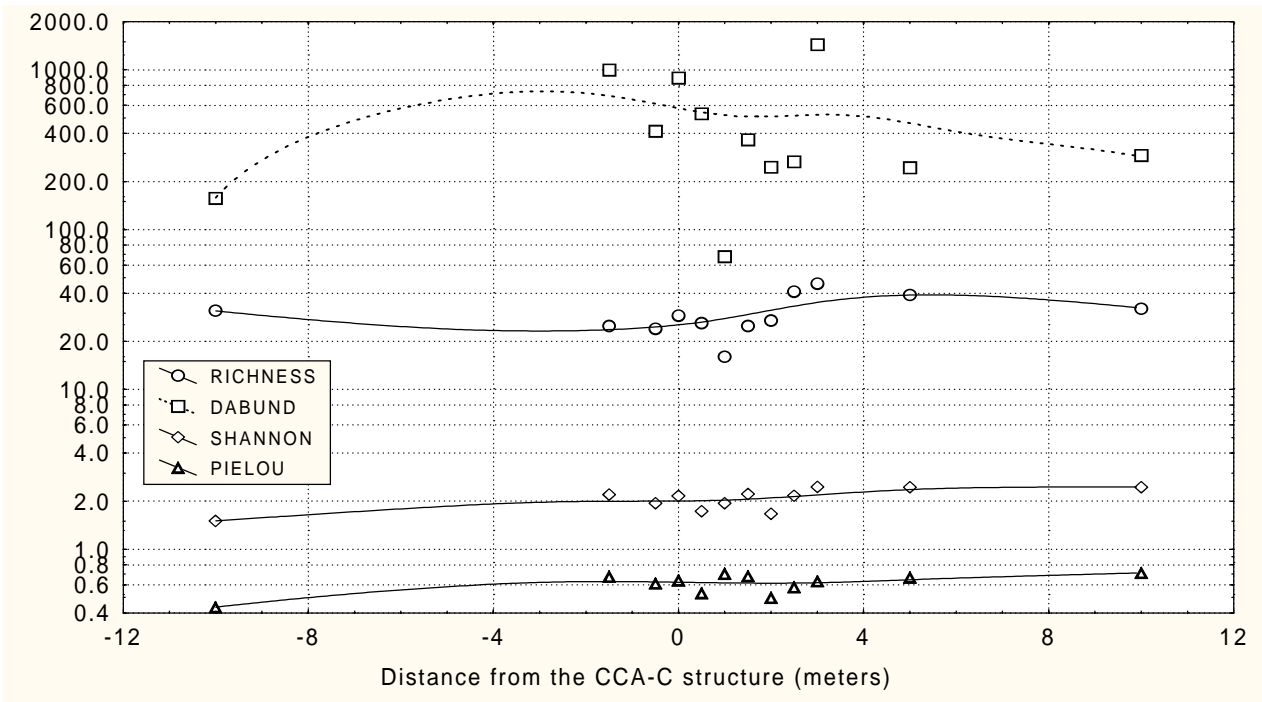

Figure II-38—Summary of total taxa richness, dominant species abundance, Shannon’s index, and Pielou’s index for infaunal samples collected on day +336 at CCA-C site.

Table II-27—Probability that regression coefficients on distance were zero for independent variables

Variable	Probability
Total taxa richness	0.304
Dominant species abundance	<u>0.031</u>
Shannon's index	0.635
Pielou's index	0.339

regression analysis. The database was restricted to distances between -1.5 and +3.0 m where the apparent increase occurred. The dependent variables were, sequentially, dominant species abundance, total taxa richness, Shannon's index, and Pielou's index. The independent variable was distance. The probability that the regression coefficient on distance was equal to zero for each dependent variable is provided in Table II-27.

The least-square equation predicting dominant species abundance is given in Equation (5). The relationship explained 49% of the variation, and the probability that both the intercept and the coefficient on distance were zero was $p = 0.03$.

The null hypothesis that the coefficient on distance was equal to zero was rejected with $p = 0.031$. The probability that the intercept was equal to zero was $p = 0.0007$.

$$\text{Dominant species abundance} = 596 - 181 \times \text{distance}$$

The relationship between dominant species abundance and sediment levels of copper and/or arsenic was also explored using regression analysis. The null hypothesis that the coefficient on these variables was zero was not rejected in either case ($p = 0.40$ for arsenic and $p = 0.43$ for copper). Therefore, while a significant decrease in infaunal dominant species abundance was observed along the downstream transect running from -1.5 to +3.0 m, the increase was apparently not associated with sedimented levels of copper or arsenic. This analysis did not reveal evidence supporting the demonstration of an adverse effect on infauna associated with sedimented metals associated with the CCA-C-treated boardwalk.

The biological evaluation of aquatic invertebrate response to the presence of the CCA-C boardwalk is summarized, using factor analysis, in Figure II-39. Dissolved copper (WCU) and sedimented copper (SEDCU), chrome (SEDCR) or

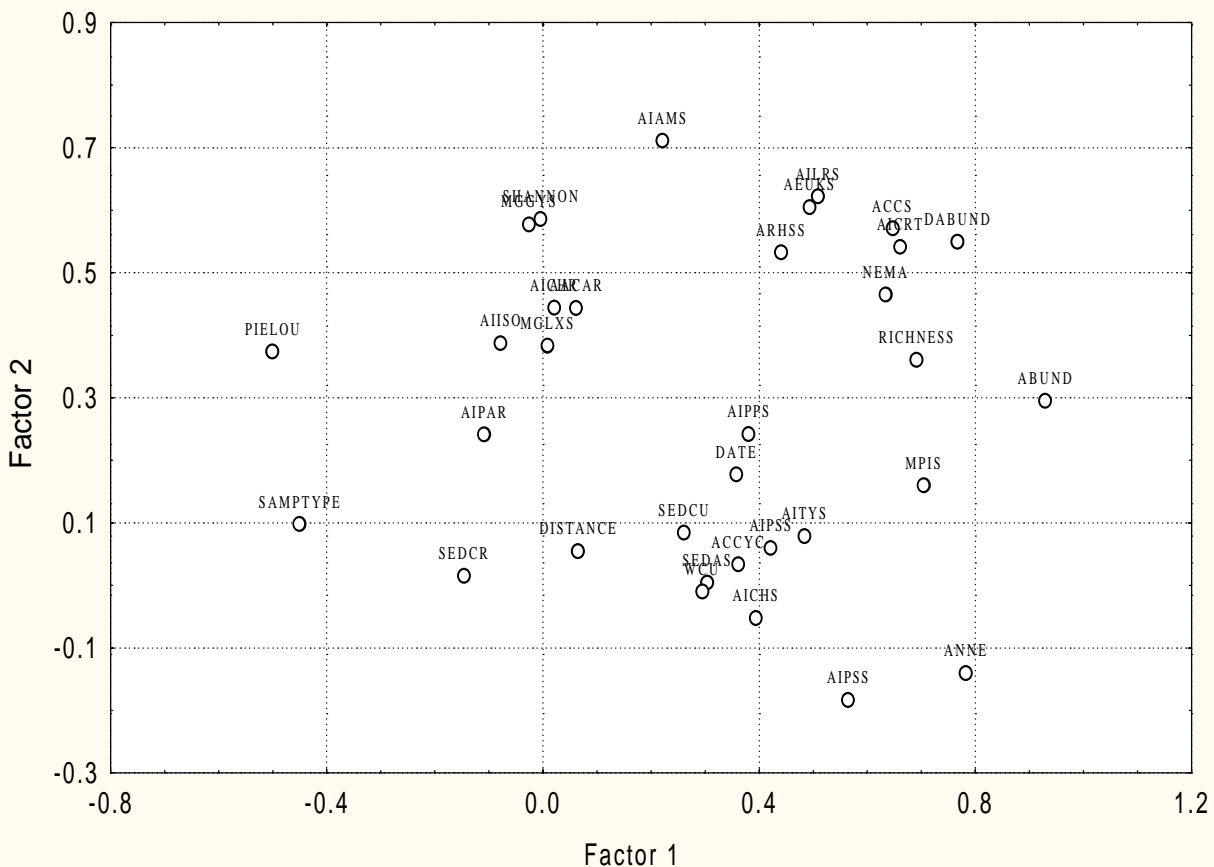

Figure II-39—Results of factor analysis on all invertebrate data collected at CCA-C site. MINRES extraction followed by Varimax normalization.

arsenic (SEDAS) are located near the origin of the Cartesian coordinate system and had no documented effect on the invertebrate community. The community is dominated by annelids of the genus *Limnodrilus* (ANNE) and mollusks of the genus *Pisidium* (MPIS) that loaded significantly on factor 1 along with the metrics total taxa abundance (ABUND) and dominant taxa abundance (DABUND). The only significant loading on factor 2 was the abundance of stoneflies of the genus *Amphinemura* (AIAMS). Shannon's diversity index was reduced by the abundance of *Pisidium* sp. and *Limnodrilus* that dominated most samples. The specific metrics evaluated and the summary provided in Figure II-39 do not indicate adverse effects on the community of invertebrates resident at this site associated with either the structure through evaluation of the metric distance or the low levels of arsenic, chrome, and copper lost to the water column and sediments during the first year following construction.

It should be emphasized that the neutral to slightly acidic pH and very low levels of hardness, alkalinity, and organic carbon observed in the Wildwood wetland environment exacerbate the potential effects of metals lost from treated wood. That statement is especially true for copper, which, as discussed by Brooks (1997a), is the metal of most concern to aquatic organisms. The very slow water currents documented at the CCA-C-treated structure allowed those metals to remain in the immediate vicinity of the structure, thus creating a worst-case study environment. The CCA-C-treated structure lost measurable but small amounts of copper, chrome, and arsenic to this environment with no documentable effect on the aquatic invertebrate community. In this instance, the levels observed in the water and sediments were not expected to create adverse effects—even with the lack of complexing agents responsible for detoxifying copper. These results appear consistent with the literature and regulatory criteria describing and controlling metal toxicity.

An argument could be made that the community of invertebrates dominating the Wildwood wetland system are relatively robust to metal intoxication. However, that community does include dominant taxa such as the Chironomids *Tanytarsus* and *Polypedilum* that have previously been identified as intolerant to copper intoxication—albeit at higher concentrations than were observed at the CCA-C treatment site (Munkittrick and others 1991, Kraft and Sypniewski 1981, Rutherford and Mellow 1994). It should also be recognized that the community of invertebrates resident in the Wildwood complex are adapted to the fine-grained sediments and very slow moving water. This environment was chosen for the assessment because these physical conditions represent a worst case with respect to minimizing the dispersal of preservative lost from CCA-C-treated wood and maximizing the resulting environmental concentration of these metals. Based on the available literature, it is unlikely that the levels of copper chrome and arsenic observed adjacent to the CCA-C site in the Wildwood environment would have a significant adverse effect on even the more

adverse effect on even the more susceptible species, such as mayflies of the genus *Hexagenia*.

Summary of Biological Effects at the CCA-C Site

Water column concentrations of copper observed on days during which biological samples were collected were well below the EPA chronic copper criterion at the observed water hardness. Note that Lebow and others (part I of this report) collected additional samples while it was raining in Wildwood on August 5, 1996 (2 months after construction) and observed a maximum copper concentration of 5.35 µg/L under the boardwalk. This value exceeded the EPA chronic criterion. Based on the observed levels of dissolved copper adjacent to the CCA-C-treated boardwalk, no adverse biological effects on invertebrates were anticipated and none was found. Chromium was not significantly elevated in sediments adjacent to the CCA-C-treated boardwalk. This is expected because chrome losses from CCA-C-treated wood that is properly fixed are very small (Brooks 1997c). Sedimented copper and arsenic concentrations were elevated above the TEC level adjacent to the structure, on day +15. This was likely associated with construction. Copper and arsenic were observed to move slowly downstream with time during the study. Metal levels immediately adjacent to the structure returned to near normal by the end of the study. Downstream metal levels remained above the TEC but below the high NEC at all times during the study. No adverse biological effects were anticipated at the low metal concentrations found in the vicinity of the CCA-C-treated structure and none was observed.

Summary of Wildwood Boardwalk Study

A total of 86,144 invertebrates were identified in the Wildwood boardwalk study. The aquatic invertebrate community included a total of 149 taxa in 97 distinct genera or families. The results of sampling vegetation, artificial substrates, and infauna are summarized in Table II-28. Infaunal samples contained the largest mean number of animals and the highest total taxa richness. The mean number of taxa/sample was between that found on vegetation and that observed on artificial substrates. Vegetation samples had an intermediate number of individuals/sample with the highest average

Table II-28—Summary of invertebrates collected in Wildwood study as function of sample type

Sample type	No. animals/sample	Mean taxa/sample	Total taxa/sample type
Infauna	321	15	118
Vegetation	232	22	104
Artificial substrate	90	11	78

richness. Samples on 0.1-m Hester–Dendy artificial substrates contained fewer invertebrates in fewer taxa than did other sample types. However, abundance and richness were sufficient to provide a meaningful analysis.

In terms of economic efficiency, the artificial substrates were quickly disassembled in the field and washed over a plankton net into sample bottles. The entire process, including disassembly, washing, and fixing, required approximately 5 min/sample. Minimal picking was required and nearly all samples could be enumerated without further processing. This proved a very efficient methodology. The fine sediments in the Wildwood wetland did not contain large amounts of finely divided organic material. They did contain significant amounts of woody debris, and 3 to 5 h/sample were required to retrieve the invertebrates from the background matrix. The vegetation samples contained significant amounts of debris and required 5 to 8 h/sample for retrieval of organisms. Replicate vegetation samples were not collected, because of the patchiness of vegetation in submerged areas of the wetland and the cost of processing the samples.

Significant effects associated with the boardwalks were not observed in any of these types of samples. In retrospect, the mix of sample types used in this study is recommended in other studies conducted in similar environments. The data provide no basis for suggesting that focusing the effort on a single type of sample would have improved the sensitivity of the analysis.

It is worthy of note that significantly fewer invertebrates were identified at all treatment sites, including the mechanical control, during the late fall–early winter sampling conducted on November 16, 1997. This sampling event was scheduled to assess the effects of sedimented metal prior to heavy winter rains that could have (in a wet year) flushed any accumulated metal out of the wetland. It would have been very difficult to compare the invertebrate community sampled on November 16, 1997 with that sampled on any other date in this study. The anticipated variability in water flow through wetlands of this type reinforces the need for controls that are independent of season. In this study, suitable controls were available at upstream stations associated with each treatment and at the mechanical control located in a remote part of the wetland.

The entire Wildwood invertebrate and metal database was evaluated using principal factors (MINRES) with and without Varimax normalization. Metal concentrations and most taxa clustered on, or very near, the origin. Interpretation of the results was significantly simplified by restricting the database to environmental parameters and only those taxa previously identified as dominant. All relationships were equally well demonstrated in the restricted database (Fig. II–40).

Table II–29 shows significant loadings (>0.7) that defined factors 1 and 2 along with nonsignificant factor loadings for metals and the metrics used in the foregoing analysis. These two factors explained 30% of the variation. Additional factors did not add significantly to the proportion of explained variation and greatly increased the difficulty of the analysis.

Metal variables lie near the origin of the Cartesian coordinate system and had little influence on either factor 1 or 2. However, note that dissolved copper and sedimented copper and chrome are clustered in a distinct location from many dominant taxa and from the normally sensitive metric richness. This may suggest a subtle effect that was not statistically significant in this study. Dominant taxa abundance and total taxa abundance varied together, substantiating the procedures used to define dominant taxa in this evaluation. However, Shannon's and Pielou's indices are distanced from either abundance metric, suggesting that these measures of community diversity and dominance were negatively influenced by increases in the total invertebrate abundance in the wetland. This suggests an environment in which a few dominant species determine the primary community structure and in which other species add minimally to the community. Based on Figure II–40, those dominant species include mollusks of the genus *Pisidium*, annelids of the genus *Limnodrilus*, nematodes, and several Chironomid genera (*Larsia*, *Psectrotanytus*, *Tanytarsus*, *Eukiefferiella*, and *Polypedilum*). Other dominant invertebrates with significant influence on the community structure appear to be isopods in the genus *Caecidotea* and Dipterans in the tribe Ceratopogoninae.

Tanytarsus sp. and *Polypedilum* sp. were previously identified as intolerant to copper intoxication by Munkittrick and others (1991). The species of this genus in the Wildwood wetland were tolerant of the metal concentrations recorded at all treatment sites in our study. However, the metal levels observed in the Wildwood wetland were much lower than those observed by Munkittrick and others (1991).

The study reported here documents measurable increases in water column and sediment concentrations of arsenic, copper, chrome, and zinc in association with the use of ACZA-, CCA–C-, and ACQ–B-treated wood structures in a wetland environment. Observed increases varied between the different types of structures.

The invertebrate community associated with the slow currents and fine sediments in the Wildwood wetland is a robust community that does not include numerous taxa previously identified as intolerant to copper. In that respect, the results of this study are similar to those of Cairns and others (1984) who found no adverse biological effects associated with sediment copper levels less than 600 mg/kg in a similarly robust community. A comparison of the invertebrate community present during baseline sampling with that observed post construction during spring and summer sampling indicated that no taxa were excluded or significantly reduced in

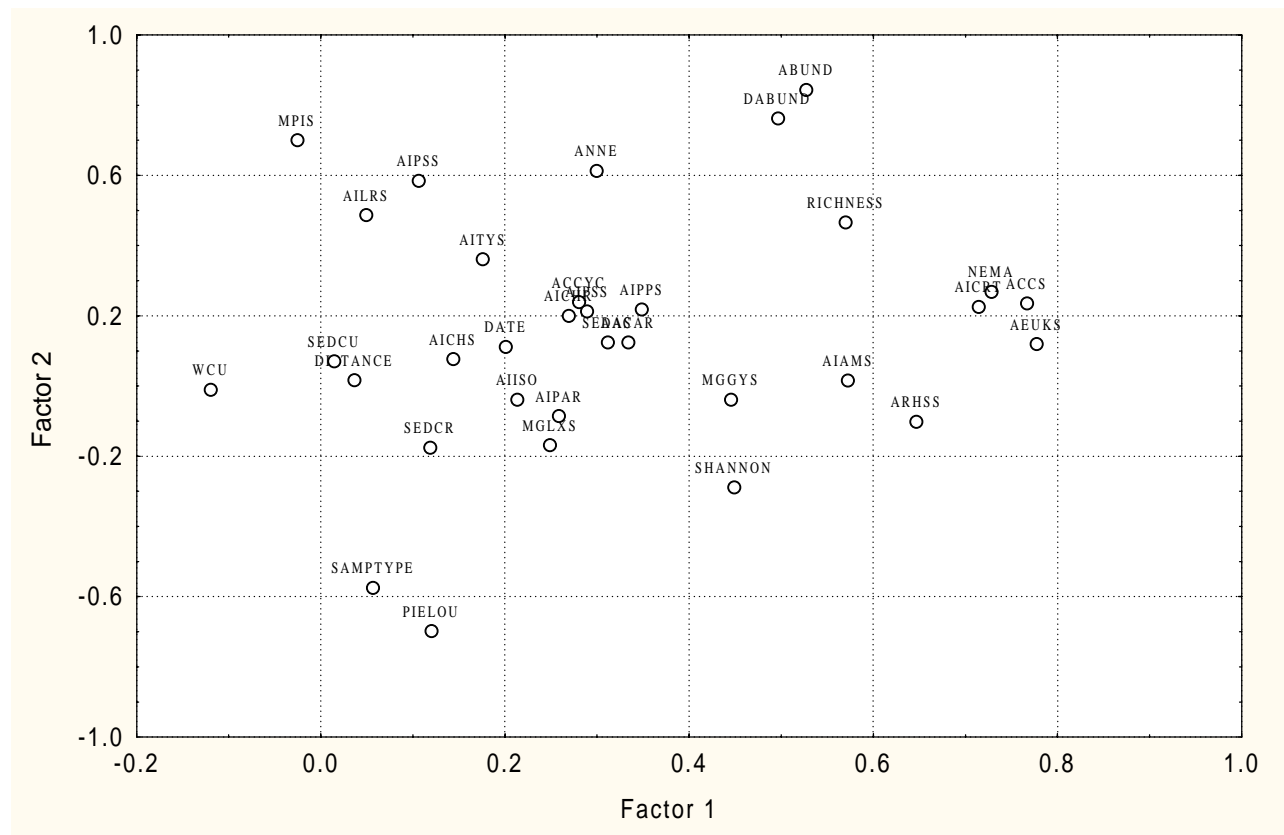

Figure II-40—Results of factor analysis on all invertebrate data collected at ACZA site. MINRES extraction followed by Varimax normalization.

Table II-29—Factor loadings associated with Figure II-40 for dominant taxa with significant loading, metals, and metrics used to analyze biological database^a

Variable	Factor 1	Factor 2
Date	0.20	0.11
Distance	0.04	0.17
Sediment copper concentration	0.01	0.07
Sediment arsenic concentration	0.31	0.12
Sediment chrome concentration	0.11	-0.18
Dissolved copper in water	-0.12	-0.01
Total taxa abundance	0.53	0.84
Total taxa richness	0.57	0.47
Dominant taxa abundance	0.50	0.76
Nematodes	0.73	0.27
Annelids	0.30	0.61
Mollusk, <i>Pisidium</i> sp.	-0.03	0.70
Amphipod, <i>Caecidotea</i> sp.	0.77	0.24
Diptera, Ceratopogoninae	0.71	0.23
Chironomid, <i>Eukiefferiella</i> sp.	0.78	0.12

^aLevel of significance $p > 0.7$.

number by any boardwalk treatment. While very subtle effects are suggested in the factor analysis, none of those effects was statistically significant. If subtle effects were present, they were very minor in nature.

Acknowledgments

The author wishes to thank the Forest Products Laboratory, USDA Forest Service; Chemical Specialties Incorporated (CSI); Hickson Corporation; Osmose Wood Preserving, Inc.; and J.H. Baxter and Company for their financial support, which made this study possible. Mr. Bruce Rungee of the Bureau of Land Management deserves special credit for his willingness to accommodate study needs in designing the boardwalk. Closer to home, Mr. Art Frost deserves special credit for his meticulous identification of the tens of thousands of larval insects collected in support of this project.

References

Ammann, L.P.; Waller, W.T.; Kennedy, J.H.; Dickson, K.L.; Mayer, F.L. 1997. Power, sample size, and taxonomic sufficiency for measures of impact in aquatic systems. *Environmental Toxicology and Chemistry*. 16(11): 2421–2431.

- Anderson, R.V.** 1977. Concentration of cadmium, copper, lead, and zinc in six species of freshwater clams. *Environmental Contamination Toxicology Bulletin*. 18(4): 492–497.
- Archer, K.J.; Jin, L.; Preston, A.F.; Richardson, N.G.; Thies, D.B.; Zahora, A.R.** 1992. ACQ: Proposal to the American Wood Preservers' Association Treatment Committee to include ammoniacal copper quat, ADCQ type B, in AWWPA standards under the jurisdiction of the Treatment Committee. Charlotte, NC: Chemical Specialties, Inc.
- AWPA.** 1996. American Wood-Preservers' Association Standards. Woodstock, MD: American Wood-Preservers' Association. 376 p.
- Boyle, E.A.** 1979. Copper in natural waters. In: Nriagu, J.O., ed.. *Copper in the environment*. Pt. I: Ecological cycling. New York: Wiley. p. 77.
- Brooks, K.M.** 1995. Assessment of the environmental risks associated with the use of treated wood in lotic systems. Vancouver, WA: Western Wood Preservers' Institute. 37 p.
- Brooks, K.M.** 1996. Evaluating the environmental risks associated with the use of chromated copper arsenate-treated wood products in aquatic environments. *Estuaries*. 19(2A): 296–305.
- Brooks, K.M.** 1997a. Literature review and assessment of the environmental risks associated with the use of ACZA treated wood products in aquatic environments. 2d ed. Vancouver, WA: Western Wood Preservers' Institute. 98 p.
- Brooks, K.M.** 1997b. Literature review, computer model and assessment of the potential environmental risks associated with creosote treated wood products used in aquatic environments. 3d ed. Vancouver, WA: Western Wood Preservers' Institute. 139 p.
- Brooks, K.M.** 1997c. Literature review and assessment of the environmental risks associated with the use of CCA treated wood products in aquatic environments. 3d ed. Vancouver, WA: Western Wood Preservers' Institute. 100 p.
- Brooks, K.M.** 1998. Literature review and assessment of the environmental risks associated with the use of ACQ treated wood products in aquatic environments. Vancouver, WA: Western Wood Preservers' Institute.
- Cain, D.J.; Luoma, S.N.; Carter, J.L.; Fend, S.V.** 1992. Aquatic insects as bioindicators of trace element contamination in cobble-bottom rivers and streams. *Canadian Journal of Fish Aquatic Science*. 49(10): 2141–2154.
- Cairns, M.A.; Nebeker, A.V.; Gakstatter, J.H.; Griffis, W.L.** 1984. Toxicity of copper-spiked sediments to freshwater invertebrates. *Environmental Toxicology and Chemistry*. 3: 435–445.
- Canfield, S.L.; Canfield, D.E., Jr.** 1994. The TEAM approach, "Together for environmental assessment and management": a process for developing lake management plans or water resource policy. *Lake and Reservoir Management*. 10: 203–212.
- Canfield, T.J.; Kemble, N.E.; Brumbaugh, W.G.; Dwyer, F.J.; Ingersoll, C.G.; Fairchild, J.F.** 1994. Use of benthic invertebrate community structure and the sediment quality triad to evaluate metal-contaminated sediment in the upper Clark Fork River, Montana. *Environmental Toxicology and Chemistry*. 13(12): 1999–2012.
- Clark, R. McV.** 1974. The effects of effluents from metal mines on aquatic ecosystems in Canada, A review. Research and Development Directorate, Freshwater Institute, Winnipeg. Report No. 46. 150 p.
- Clements, W.H.; Cherry, D.S.; Cairns, J. Jr.** 1988. Impact of heavy metals on Insect communities in streams: A comparison of observational and experimental results. *Canadian Journal of Fisheries and Aquatic Sciences*. 45: 2017–2025.
- Clements, W.H.; Cherry, D.S.; Van Hassel, J.H.** 1992. Assessment of the impact of heavy metals on benthic communities at the Clinch River (Virginia): Evaluation of an index of community sensitivity. *Canadian Journal of Fisheries and Aquatic Sciences*. 49: 1686–1694.
- Crocket, J.H.; Kabir, A.** 1981. Geochemical pathway studies of heavy metals in lake sediments from the Sudbury–Temagami Area, Ontario. *Journal of Great Lakes Research*. 7(4): 455–466.
- Diks, D.M.; Allen, H.E.** 1983. Correlation of copper distribution in a freshwater-sediment system to bioavailability. *Environmental Contamination Toxicology Bulletin*. 30: 37–43.
- Findlay, D.M.; Richardson, H.G.** 1983. Wood treatment composition. Canadian Patent 1,146,704.
- Findlay, D.M.; Richardson, H.G.** 1990. Wood treatment composition. U.S. Patent 4,929,454.
- Flemming, C.A.; Trevors, J.T.** 1988. Copper retention and toxicity in a freshwater sediment. *Water, Air, and Soil Pollution*. 40(3–4): 419–432.
- Gower, A.M.; Myers, G.; Kent, M.; Foulkes, M.E.** 1994. Relationships between macroinvertebrate communities and environmental variables in metal-contaminated streams in southwest England. *Freshwater Biology*. 32(1): 199–221.
- Harrison, F.L.; Knezovich, J.P.; Rice, D.W.; Lam, J.R.** 1987. Distribution, fate, and effects of energy-related residuals in marine environments. In: Dorigan, J.V.; Harrison, F.L., eds. *Physiological responses of marine organisms to environmental stresses*. Washington, DC: U.S. Department of Energy, Office of Energy Research, Office of Health and Environmental Research, Ecological Research Division.

- Hendriks, J.A.** 1995. Modeling equilibrium concentrations of microcontaminants in organisms of the Rhine Delta: Can average field residues in the aquatic foodchain be predicted from laboratory accumulation. *Aquatic Toxicology*. 31: 1–25.
- Hovmand, M.F.** 1979. Atmospheric heavy metal deposition on land and sea. In: Proceedings, International Council for Exploration of the Sea, 67th statutory meeting; 1979, October; Warszawa, Poland: 8 p.
- Hupp, C.R.; Woodside, M.D.; Yanosky, T.M.** 1993. Sediment and trace element trapping in a forested wetland, Chickahominy River, Virginia. *Wetlands*. 13(2): 95–104.
- Hutchinson, T.C.** 1979. Copper contamination of ecosystems caused by smelter activities. In: Nriagu, J.O., ed. *Copper in the Environment*. Pt. I: Ecological cycling. New York: John Wiley and Sons. p. 451.
- Jones, D.S.; Suter, G.W. II; Hull, R.N.** 1997. Toxicological benchmarks for screening contaminants of potential concern for effects on sediment-associated biota: 1997 revision. Report ES/ER/TM–95/R4. Prepared for U.S. Department of Energy, Office of Environmental Management, Oak Ridge National Laboratory, Oak Ridge, TN.
- Kerrison, P.H.; Annoni, D.; Zarini, S.; Ravera, O.; Moss, B.** 1988. Effects of low concentrations of heavy metals on plankton community dynamics in a small, shallow, fertile lake. *Journal of Plankton Research*. 10(4): 779–782.
- Kiffney, P.M.; Clements, W.H.** 1994. Effects of heavy metals on a macroinvertebrate assemblage from a Rocky Mountain stream in experimental microcosms. *Journal of the North American Benthological Society*. 13(4): 511–523.
- Knezovich, J.P.; Harrison, F.L.; Tucker, J.S.** 1981. The influence of organic chelators on the toxicity of copper to embryos of the Pacific oyster, *Crassostrea gigas*. *Archives of Environmental Contamination and Toxicology*. 10: 241–249.
- Kraft, K.J.; Sypniewski, R.H.** 1981. Effect of sediment copper on the distribution of benthic macroinvertebrates in the Keweenaw Waterway. *Journal of Great Lakes Research*. 7(3):258–263.
- Larsen, V.J.** 1983. The significance of atmospheric deposition of heavy metals in four Danish lakes. *Science of Total Environment*. 30: 111–127.
- Loehr, L.** 1997. Dangerous levels of arsenic in public drinking water supplies? *SEATAC News*. 17(4): 22.
- Long, E.R.; Morgan, L.G.** 1991. The potential for biological effects of sediment-sorbed contaminants tested in the national status and trends program. NOAA Technical Memorandum NOS OMA 52, National Oceanic and Atmospheric Administration: 175 p.
- Long, E.R.; MacDonald, D.D., Smith, S.L.; Calder, F.D.** 1995. Incidence of adverse biological effects within ranges of chemical concentrations in marine and estuarine sediments. *Environmental Toxicology and Chemistry*. 19(1): 81–97.
- Lu, J.C.S.; Chen, K.Y.** 1976. Migration of trace metals in interfaces of seawater and polluted surficial sediments. *Environmental Science and Technology*. 11:174–182.
- Ludwig, J.A.; Reynolds, J.F.;** 1988. *Statistical ecology—a primer on methods and computing*. New York: John Wiley and Sons. 337 p.
- MacDonald, D.D.; Charlish, B.L.; Haines, M.L.; Brydges, K.** 1994. Approach to the assessment of sediment quality in Florida coastal waters: Vol. 3. Supporting documentation: Biological effects database for sediment. Tallahassee, FL: Florida Department of Environmental Protection.
- Margalef, R.** 1958. Information theory in ecology. *General Systematics*. 3: 36–71.
- Miller, P.A.; Munkittrick, K.R.; Dixon, D.G.** 1992. Relationship between concentrations of copper and zinc in water, sediment, benthic invertebrates, and tissues of white sucker (*Catostomus commersoni*) at metal-contaminated sites. *Canadian Journal of Fisheries and Aquatic Sciences*. 49(5): 978–984.
- Moore, J.W.; Beaubien, V.A.; Sutherland, D.J.** 1979. Comparative effects of sediment and water contamination on benthic invertebrates in four lakes. *Environmental Contamination. Toxicology Bulletin*. 23: 840–847.
- Munkittrick, K.R.; Dixon, D.G.** 1989. Effects of natural exposure to copper and zinc on egg size and larval copper tolerance in white sucker (*Castostomus commersoni*). *Ecotoxicology and Environmental Safety*. 18(1): 15–26.
- Munkittrick, K.R.; Miller, P.A.; Barton, D.R.; Dixon, D.G.** 1991. Altered performance of white sucker populations in the Manitowadge chain of lakes is associated with changes in benthic macroinvertebrate communities as a result of copper and zinc contamination. *Ecotoxicology and Environmental Safety*. 21: 318–326.
- National Academy of Sciences.** 1971. Radioactivity in the marine environment. Panel on radioactivity in the marine environment. New York: National Academy of Sciences. p. 168.
- Nuria, I.; Kraak, M.H.S.; Admiraal, W.** 1995. Use of lake water in testing copper toxicity to Desmid species. *Water Research*. 29(9): 2113–2117.
- Pielou, E.C.** 1977. *Mathematical Ecology*. New York: John Wiley and Sons.

- Plumb, R.H. Jr.** 1981. Procedures for handling and chemical analysis of sediment and water samples. Tech. Rep. EPA/CE-81-1. Vicksburg, MS: U.S. Army Corps of Engineers. 478 p.
- PSEP.** 1986. Puget Sound protocols. Prepared for U.S. Environmental Protection Agency, Region 10, Seattle, WA.
- Puckett, L.J.; Woodside, M.D.; Libby, B.; Schening, M.R.** 1993. Sinks for trace metals, nutrients, and sediments in wetlands of the Chickahominy River near Richmond, Virginia. *Wetlands*. 13(2): 105-114.
- Rai, U.N.; Sinha, R.D.S.; Tripathi, R.D.; Chandra, P.** 1995. Wastewater treatability potential of some aquatic macrophytes: Removal of heavy metals. *Ecological Engineering*. 5: 5-12.
- Rehfeldt, G.; Sochtig, W.** 1996. Heavy metal accumulation by *Baetis rhodani* and macrobenthic community structure in running waters of the N'Harz Mountains (Lower Saxony/FRG). *Entomologia Generalis*. 16(1): 31-37.
- Rutherford, J.E.; Mellow, R.J.** 1994. The effects of an abandoned roast yard on the fish and macroinvertebrate communities of surrounding beaver ponds. *Hydrobiologia*. 294: 219-228.
- Schmidt, R.L.** 1978. Copper in the marine environment. Part II. *Critical Reviews in Environmental Control*. 8(3): 247-291.
- Shannon, C.E.; Weaver, W.** 1949. *The mathematical theory of communication*. Urbana, IL: University of Illinois Press.
- Siipola, M.D.** 1991. Memorandum for record—Columbia River salmon flow measurements, sediment quality evaluation. CENPP-PE-HR (1110-2-1150). Portland, OR: Army Corps of Engineers, Portland Office.
- Strathman, M.F.** 1987. *Reproduction and development of marine invertebrates of the Northern Pacific Coast*. Seattle, WA: University of Washington Press. 670 p.
- Sunda, W.G.** 1987. Cited in Chapter 2: Physiological responses of marine organisms to environmental stresses. In: Dorigan, J.V.; Harrison, F.L., eds. Washington, DC: U.S. Department of Energy, Office of Energy Research, Office of Health and Environmental Research, Ecological Research Division.
- Suter, G.W. II; Tsao, C.L.** 1996. Toxicological benchmarks for screening potential contaminants of concern for effects on aquatic biota: 1996 revision. ORNL Report ES/ER/TM-96/RT2. Oak Ridge, TN: Risk Assessment Program, Health Sciences Research Division.
- Tetra Tech.** 1994. Lower Columbia River backwater reconnaissance survey. Vol. 1. Reconnaissance report. Redmond, WA: Tetra Tech.
- U.S. Department of Agriculture.** 1980. The biologic and economic assessment of pentachlorophenol, inorganic arsenicals and creosote. Vol. I. Wood preservatives. USDA Technical Bulletin Number 1658-1. 435 p.
- U.S. EPA.** 1985. Water quality criteria. Fed. Reg., Vol. 50, No. 146, Part II. Washington, DC: U.S. Environmental Protection Agency: 3,0784-3,0796
- U.S. EPA.** 1995. Water quality standards; establishment of numeric criteria for priority toxic pollutants; states' compliance—Revision of metals criteria. Fed. Reg. Vol. 60, No. 86, p. 22,229 (Rule). Washington, DC: U.S. Environmental Protection Agency.
- Van Eeden, P.H.; Schoonbee, H.J.** 1993. Metal concentrations in sediments and some organisms from a polluted wetland. *South Africa Journal Wildlife Research*. 23(1): 12-16.
- WWPI.** 1996. *Best management practices for the use of treated wood in aquatic environments*. Vancouver, WA: Western Wood Preservers' Institute.

Appendix—Terms for Variables and Inventory of Taxa

This appendix lists study variables, study taxa, and taxon abbreviations used in figures in the text.

Variables

Abundance	Number of organisms/sample
Date	Sampling date
Distance	Distance from boardwalk (m)
Dominant taxa abundance	Dominant taxa abundance (>1.0% of total)
Margalef	Margalef's index
Pielou	Pielou's evenness index
Richness	Number of taxa/station
Sample type	Sample type (grab, artificial substrate, vegetation)
SEDAS	Sediment arsenic concentration (ppm dry weight)
SEDCR	Sediment chromium concentration (ppm dry weight)
SEDCU	Sediment copper concentration (ppm dry weight)
SEDZN	Sediment zinc concentration (ppm dry weight)
Shannon	Shannon's diversity index
WCU	Dissolved copper in water column (µg/L)

Taxa

CHYD	Hydrozoa
NEMA	Nematoda
ANNE	Annelida (<i>Limnodrilus</i> sp.)
MGSTL	Stylommatophora
	Mollusks
MGLXS	<i>Lanx</i> sp.
MGLYS	<i>Lymnaea</i> sp.
MGPHS	<i>Physa</i> sp.
MGGYS	<i>Gyraulus</i> sp.
HGHS	<i>Helisoma</i> sp.
MPIS	<i>Pisidium</i> sp.
AACAR	Acarina
AARAN	Araneae
ACRUST	Crustacea
ACDS	<i>Daphnia</i> sp.
ACCYC	Cyclopoida
ACAMP	Amphipoda
ACHYS	<i>Hyalella</i> sp.
ACCS	<i>Caecidotea</i> sp.
ACOST	Ostracoda
AIPA	<i>Podura aquatica</i>
AINEA	<i>Neanura</i> sp.
AIISO	Isotomidae
AIDIC	<i>Dicyrtoma</i> sp.
AIEP	Ephemeroptera
AIBAE	<i>Baetis</i> sp.
AICAL	<i>Callibaetis</i> sp.
AIHEP	Heptageniidae
AICYN	<i>Cynigma</i> sp.
AIPAR	<i>Paraleptophlebia</i> sp.
AICOE	Coenagrionidae
AICOES	<i>Coenagrion</i> or <i>Enallagma</i> sp.
AIAS	<i>Aeshna</i> sp.
AILS	<i>Libellula</i> sp.
AIPLE	Plecoptera
AINEM	Nemouridae
AIAMS	<i>Amphinemura</i> sp.
AIOS	<i>Ostrocerca</i> sp.
AICHL	Chloroperlidae
AIPER	Perlodidae
AITHER	Thripidae

Taxa—con.

AIHET	Heteroptera
AICOR	Corixidae
AISS	<i>Sigara</i> sp.
AIGS	<i>Gerris</i> sp.
AIMS	<i>Microvelia</i> sp.
AIMIR	Miridae
AIHOM	Homoptera
AICIC	Cicadellidae
AIPSY	Psyllidae
AIAPH	Aphididae
AIORT	Ortheziidae
AISSL	<i>Sialis</i> sp. (larva)
AISSA	<i>Sialis</i> sp. (adult fragments)
AINEU	Neuroptera
AIHEM	Hemerobiidae
AICOL	Coleoptera
AICAR	Carabidae
AIHSA	<i>Haliplus</i> sp. (adult)
AIHSL	<i>Haliplus</i> sp. (larva)
AIHYO	Hydroporinae
AIHSA	<i>Hydroporus</i> sp. (adult)
AILSA	<i>Laccommis</i> sp. (adult)
AICOLY	Colymbetinae
AIASL	<i>Agabus</i> sp. (larva)
AIASA	<i>Agabus</i> sp. (adult)
AIRS	<i>Rhantus</i> sp.
AIGSL	<i>Gyrinus</i> sp. (larva)
AIHYD	Hydrophilidae
AIES	<i>Enochrus</i> sp.
AIPAS	<i>Paracymus</i> sp.
AISTA	Staphylinidae
AIPTI	Ptiliidae
AIELM	Emidae
AINS	<i>Narpus</i> sp.
AICOC	Coccinellidae
AIDS	<i>Donacia</i> sp.
AICUR	Curculionidae
AISCO	Scolytidae
AITRI	Trichoptera
AIPOS	<i>Polycentropus</i> sp.
AIHYDP	Hydroptilidae
AIOSL	<i>Oxyethira</i> sp. (larva)
AIRHS	<i>Rhyacophila</i> sp.
AIBS	<i>Banksiola</i> sp.
AILIM	Limnephilidae
AICHS	<i>Chyranda</i> sp.
AIHAS	<i>Halesochila</i> sp.
AILES	<i>Lenarchus</i> sp.
AILIS	<i>Limnephilus</i> sp.
AIPSSS	<i>Psychoglyph</i> sp.
AIMIS	<i>Micrasema</i> sp.
AILPS	<i>Lepidostoma</i> sp.
AILEP	Lepidoptera
AIGEO	Geometridae
AIDIP	Diptera (1)

Taxa—con.

AITIP	Diptera (2)
AILMO	Limoniinae
AIDIS	<i>Dicranota</i> sp.
AIERS	<i>Erioptera</i> sp.
AIHES	<i>Hesperoconopa</i> sp.
AIPDS	<i>Pedicia</i> sp.
AIRHS	<i>Rhabdomastix</i> sp.
AITPS	<i>Tipula</i> sp. (adult)
AIBTS	<i>Bittacomorpha</i> sp.
AIDSA	<i>Dixella</i> sp. (adult)
AIDSL	<i>Dixella</i> sp. (larva)
AICRT	Ceratopogoninae
AIATS	<i>Atrichopogon</i> sp.
AICHR	Chironomidae
AITNY	Tanypodinae
AILRS	<i>Larsia</i> sp.
AIPAS	<i>Paramerina</i> sp.
AIPRS	<i>Procladius</i> sp.
AIPSS	<i>Psectrotanypus</i> sp.
AICHS	<i>Chironomus</i> sp.
AIGLS	<i>Glyptotendipes</i> sp.
AIPPS	<i>Polypedilum</i> sp.
AITBS	<i>Tribelos</i> sp.
AITYS	<i>Tanytarsus</i> sp.
AIORT	Orthoclaadiinae
AEUKS	<i>Eukiefferiella</i> sp.
APCLS	<i>Parorthocladus</i> sp.
APSTS	<i>Psectrocladius</i> sp.
ARHS	<i>Rheocricotopus</i> sp.
ARHSS	<i>Rheosmittia</i> sp.
ASIM	Simuliidae
ASS	<i>Simulium</i> sp.
APSY	Psychodidae
AMS	<i>Maruina</i> sp.
ACEC	Cecidomyiidae [terrestrial]
AANI	Anisopodidae [terrestrial]
ASCI	Sciaridae [terrestrial]
ACHS	<i>Chrysops</i> sp.
AGLS	<i>Glutops</i> sp.
ASTRA	Stratiomyidae
ASTS	<i>Stratiomys</i> sp. (larva)
AEMP	Empididae
ADOLI	Dolichopodidae
ALONS	<i>Lonchoptera</i> sp.
AEPHY	Ephydriidae
AMUS	Muscidae
ATAC	Tachinidae [terrestrial]
AHYM	Hymenoptera
ABRAC	Braconidae
AICH	Ichneumonidae
AFORM	Formicidae [terrestrial]
AHAL	Halictidae [terrestrial]
CPIS	Pisces
CAUR	Urodela