

Preprint 01-114

EFFECTS OF WATER SPRAYS USED WITH A MACHINE-MOUNTED SCRUBBER ON FACE METHANE CONCENTRATIONS

C. D. Taylor and J. A. Zimmer
Natl Inst for Occupatnl Sfty and Health
Pittsburgh, PA, USA

ABSTRACT

This study was conducted to determine the effects of a machine-mounted scrubber and water sprays on face methane levels. Testing was conducted in the NIOSH ventilation test gallery which was designed to simulate a full-scale mine entry. In the test entry, a model mining machine, equipped with water sprays and a simulated dust scrubber, was located at the face of a 20-ft box cut. Blowing ventilation was provided using a curtain with a 40-ft setback distance. Methane released from a pipe manifold located inby the mining machine was monitored at six locations that were 1 ft outby the pipe manifold. Tests were first conducted to evaluate the effects of using sprays and scrubber separately on face methane levels. Additional tests were conducted to determine how a scrubber used with various water spray systems would affect face methane levels. The use of either sprays or scrubber reduced face methane levels significantly. The combined use of sprays with the scrubber further reduced face methane levels a small amount. Primarily the sprays affected methane levels by changing airflow distribution close to the face.

INTRODUCTION

To have effective face ventilation, the intake air delivered to the end of the tubing or brattice must reach the face. Studies have shown that often only a small fraction of the intake air exiting the end of the curtain or tube actually reaches the face (Thimons, 1999). The amount of air reaching the face usually decreases the greater the tubing or curtain setback distance. Research conducted concurrently with the development of extended cut mining methods demonstrated that machine-mounted water sprays and scrubbers could be used to help direct additional intake air to the mining face when setback distances exceeded 20 ft (Volkwein, 1985).

Although designed primarily for dust control, machine-mounted water sprays and scrubbers play an important role in increasing the amount of intake air that reaches an extended cut mining face. A water spray moves air like a small fan. When used with exhaust ventilation, groups of sprays directed 30° toward the return side of the entry create airflow patterns that help clear methane from the face.

On sections with blowing ventilation, the large quantities of air moved by machine-mounted dust scrubbers affect face airflow patterns. Tests using scrubbers with both blowing and exhausting ventilation show that operation of a scrubber always reduces face methane concentrations unless the scrubber exhaust flow interferes with the movement of the intake air toward the face (Taylor, 1996).

Most exhaust ventilation sections use sprays but no scrubbers. Sprays with a scrubber are used together on most sections that have blowing ventilation. Past research to evaluate the effects of scrubber use on face methane levels has been conducted with operating spray systems. Using a scrubber and sprays together reduced face methane levels for a range of setback distances, and scrubber and intake flows (Taylor, 1996). Another study showed that water spray systems, regardless of design, improved methane control when used with scrubbers. However, ventilation improved most when the spray system was directed toward the return side of the face (Volkwein and Wellman, 1989).

The current research is a continuation of earlier studies to evaluate how the combined use of scrubbers and water sprays affect face methane levels while using blowing ventilation. Tests were conducted for a range of operating conditions that included multiple drum heights and the use of side and underboom sprays.

TEST FACILITY

Gallery

Testing was conducted in the NIOSH Pittsburgh Research Laboratory's Ventilation Test Gallery. One side of the "L" shaped building is designed to model an underground mining entry which is 16.5 ft wide by 7 ft high (Figure 1). An exhaust fan draws approximately 12,500 cfm of air into the gallery. For these tests a brattice and wood curtain, constructed 2 ft from the left side of the entry directed 7,500 cfm of intake air toward the face. Curtain setback distance for all tests was 40 ft. The return air was pulled from the gallery behind a brattice and wood wall built along the right side of the entry. A 4-ft wide by 20-ft long box was built along the right side of the face to simulate an uncut slab of coal. A box cut, rather than a slab cut configuration, was selected because changes in methane levels inby the cutting head are easier to detect in the more confined area of the box cut.

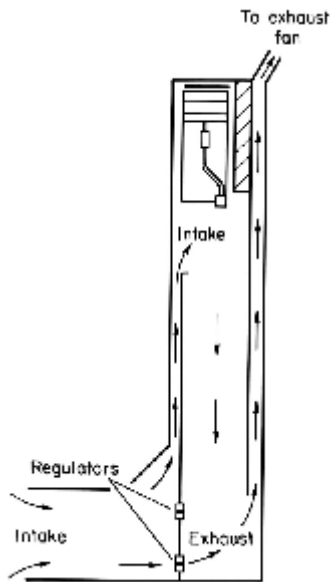

Figure 1. Ventilation test gallery.

Mining Machine

A full-scale model mining machine was located at the center of the 12.5 ft wide box cut face (Figure 2). During testing the cutting head rotated at 40 rpm and the center of the drum was positioned approximately 20, 40 and 60 in. above the floor (Figure 3). These locations are referred to as the "down," "middle," and "up" drum heights. The mining machine was equipped with a simulated dust scrubber. A fan mounted in the machine drew air into two 10 by 14 in. scrubber inlets located below and just behind the machine boom (Figure 4). An

orifice plate was placed in the scrubber duct to limit flow to approximately 7,000 cfm for all tests where the scrubber was operating. Air from the scrubber was exhausted through a 15 by 15 in. opening at the right rear of the machine and directed straight back the entry toward the return. The water spray system included manifolds located on the top, side and under the boom (Figure 5).

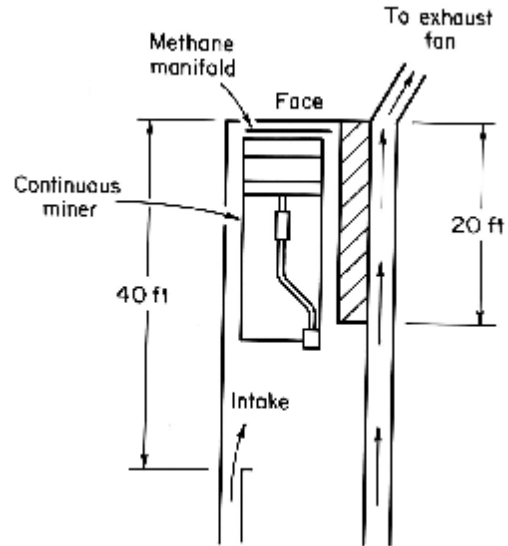

Figure 2. Model mining machine at face of box cut.

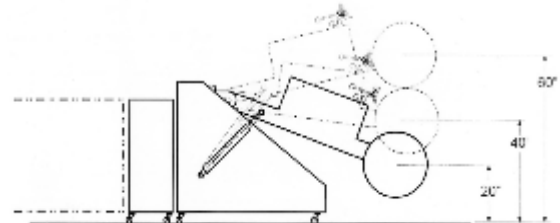

Figure 3. Drum test heights.

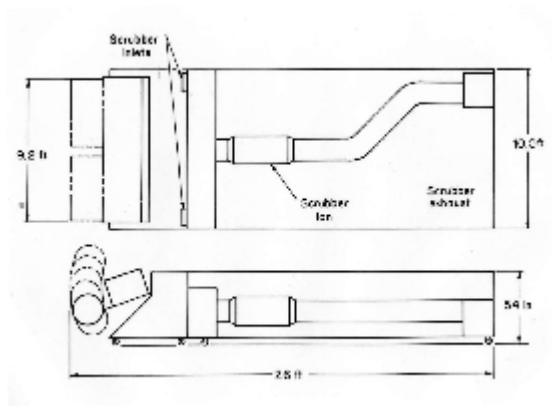

Figure 4. Scrubber location on model mining machine.

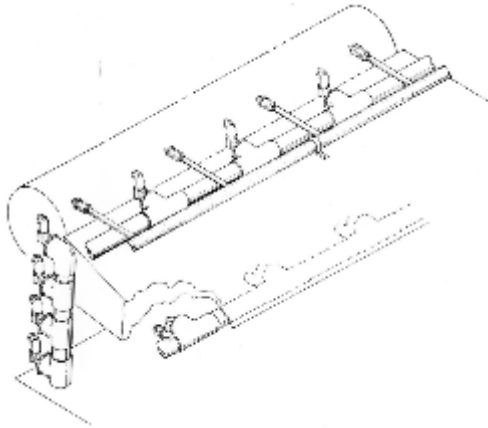

Figure 5. Spray locations on model mining machine.

Water Spray Systems

Top spray manifold: Ten BD-3 hollow jet nozzles were mounted approximately 12 in. apart in each of two 10-ft long plastic pipes located on top of the miner boom. The sprays in one pipe were directed straight toward the face. In the other pipe they were directed 30° to the right. All spray nozzles were approximately 30 in. from the face.

Side spray manifold: Four Vee-jet nozzles were positioned 6 in apart in a 28-in. plastic pipe that was mounted vertically on the left side of the mining machine. The flat spray nozzles were aligned so that the spray pattern was vertical and directed toward the face.

Underboom spray manifold: Four BD-3 hollow jet nozzles were positioned 6 in. apart in a 28-in. plastic pipe that was attached to the underside of the cutting boom. The nozzles were mounted in swivel fittings that allowed them to be directed toward the face or angled to the right.

Water flow and pressure: The water pressure provided by a centrifugal pump was measured at a gauge mounted near the front of the model mining machine. Flows and pressures varied depending on the number of operating sprays. For all tests using water sprays, pressures were maintained between 110 and 130 psi and the flow was allowed to vary depending on the number of sprays operating. Pressure at the gauge was adjusted by redirecting part of the water flow at the pump.

METHANE RELEASE AND INSTRUMENTATION

Methane gas was released into the gallery through four horizontal copper pipes that were drilled on top and bottom with 1/16 in. diameter holes (Figure 6). The pipes were equally spaced horizontally, and located 4 in. away from the face to provide a relatively uniform release of gas.

Methane was released at a flow rate of approximately 45 cfm. For some tests, however, the gas flow was reduced to prevent concentrations in the gallery from exceeding 2 pct. Methane gas concentrations were measured at the six locations shown on Figure 6.

- Locations 1, 2, and 3 are 1ft from the roof and face, evenly spaced across the face
- Locations 4, 5, and 6 are 1ft from the face and 4 ft below locations 1, 2 and 3.

A vacuum pump was used to draw an air sample at 0.5 lpm from each of the six sampling locations. Each air sample was drawn through 30 ft of 1/4 in. plastic tubing and passed over an individual catalytic heat of combustion type sensor head.

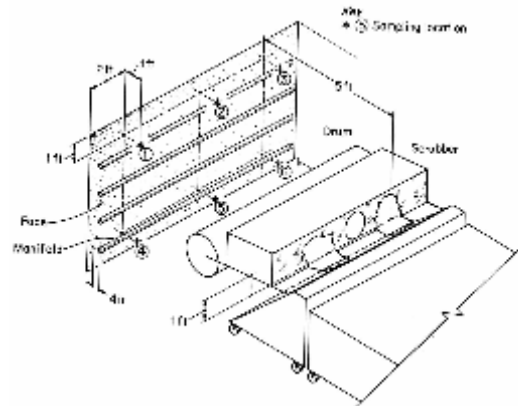

Figure 6. Gas release and sampling locations at the model face.

TEST PROCEDURE

After setting up the operating conditions (spray configuration, scrubber and intake flow, and cutting head height) for each test, gas was injected through the manifold for five minutes to allow time for the gas and air to mix and reach a relatively steady state in the gallery. After allowing time for mixing, data was collected for an additional five minutes. Concentration data from each methanometer was down-loaded to a personal computer via a Metrabyte¹ A/D conversion board for the entire ten minute test. Lab Tech software was used to organize and store the data, and a computer spreadsheet was used to calculate the average methane concentrations for each of the six sampling locations. Tests were repeated once and the results averaged.

An "overall" average concentration was calculated for all six sampling locations, and group average concentrations were calculated for samples on the

¹Reference to specific manufacturers does not imply endorsement by NIOSH.

“left” (locations 1 and 4), “center” (locations 2 and 5) and “right” (locations 3 and 6) of the face. The effectiveness of the face ventilation provided by the different spray and scrubber systems was determined by comparing average methane concentrations.

RESULTS

Methane concentrations measured with only the scrubber or sprays operating were compared to concentrations during tests with neither operating. Only the top-mounted 30° sprays were used for these tests. The scrubber was operated at 7,000 cfm. Due to a mechanical problem during this series of tests, data was obtained only with the drum at the middle and down heights. Figure 7 shows that the use of the scrubber or water sprays reduced methane concentrations at the left, center and right side of the face. Overall average reductions due to the use of the scrubber or sprays were 70 and 56 pct respectively.

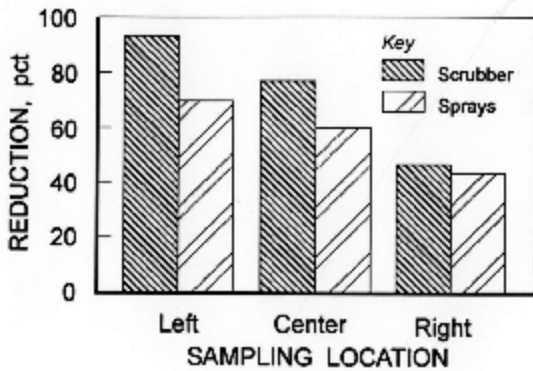

Figure 7. Effect of drum height on methane levels using top mounted sprays at three face areas.

Additional tests were conducted using the scrubber and either the 30° or straight top sprays. Data was obtained with the drum at three heights. Figure 8 shows average concentration data obtained with the drum at all three heights for the left, center and right face sampling locations. At each location, methane concentrations were slightly higher when using the straight sprays. Overall average face concentrations with the straight sprays were about 14 pct higher than with the 30° sprays.

Drum height also had an effect on methane concentrations when either top spray system was used with the scrubber. Figure 9 shows the combined average for all six face location concentrations calculated for the straight and 30° spray systems at each drum height. With the drum up, average face methane concentrations with the two top water sprays systems were about 30 pct higher than when the drum was down. Average

face concentrations were lowest when the drum was at the middle height.

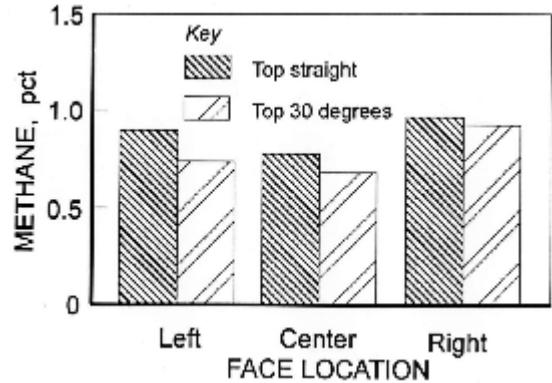

Figure 8. Comparison of methane reduction with top mounted sprays at three face areas.

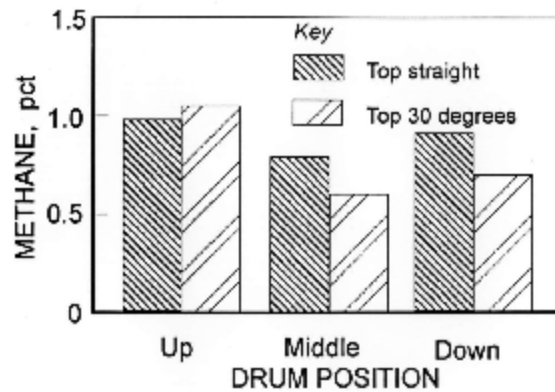

Figure 9. Effect of drum heights on methane levels using top mounted sprays.

Remaining tests were conducted only with the drum up and the top water sprays (either straight or 30°) and scrubber operating. Scrubber and intake flow were maintained at 7,000 cfm. Using underboom sprays with the nozzles directed straight toward the face, and top 30° sprays, methane levels increased 42 pct on the left side of the face (Figure 10). Methane levels on the right side of the face increased 66 pct when the side sprays were used with the top straight sprays (Figure 11).

Combining use of the underboom and side sprays with the top 30° sprays reduced left side methane concentrations 39 pct (Figure 12). Right side concentrations were reduced 50 pct when the underboom and side sprays were used with the top straight sprays.

For the tests conducted with the underboom sprays, the spray nozzles were directed straight toward the face. With the drum up and the 30° top sprays operating, tests were conducted with the underboom sprays angled approximately 45° to the right. Figure 13 shows a comparison between face concentrations measured with underboom straight

and underboom angled sprays. With the underboom sprays angled 45°, the average face concentration on the left side of the face was reduced 60 pct.

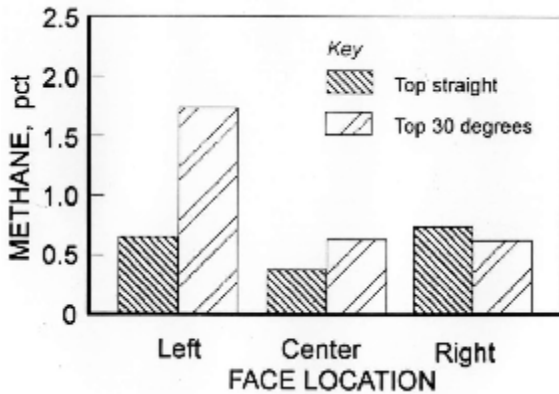

Figure 10. Using underboom sprays with the top sprays.

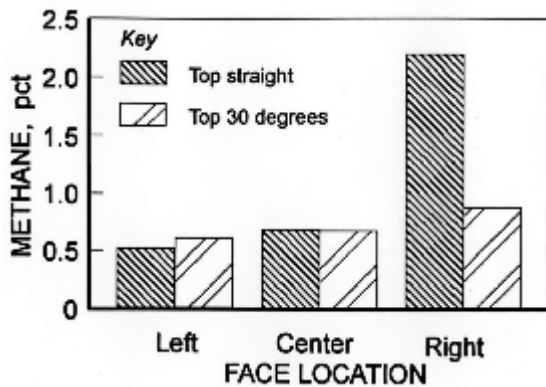

Figure 11. Using side sprays with the top sprays.

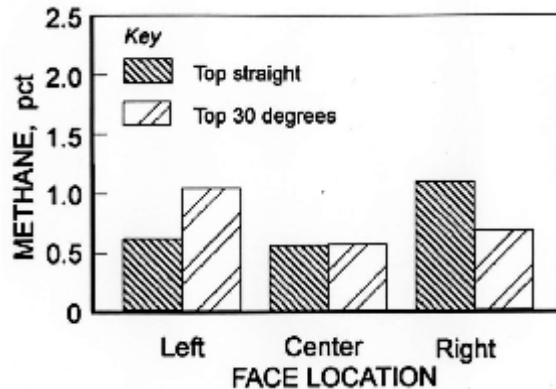

Figure 12. Combined use of underboom and side sprays with top sprays.

DISCUSSION AND CONCLUSION

Methane concentrations at the face were reduced significantly when either water sprays or the scrubber were turned on. Baseline airflow patterns were drawn for face ventilation provided only by the blowing curtain (7,000 cfm) set at a 40-ft setback

distance. Using smoke tubes airflow patterns were drawn for the baseline condition, and ventilation with either the scrubber or sprays operating (Figure 14). Ventilation with only the blowing curtain created a "figure 8" flow pattern that moved from the return to the intake side of the face. Operation of the scrubber or water sprays reversed the direction of the face airflow resulting in movement from the intake to the return side of the face. Based on observations of the smoke flow, more intake air reached the face with only the scrubber operating, and the flow patterns were straighter and better defined. Establishing a face airflow that moves from the intake to return side of the entry is an important factor in reducing face methane levels.

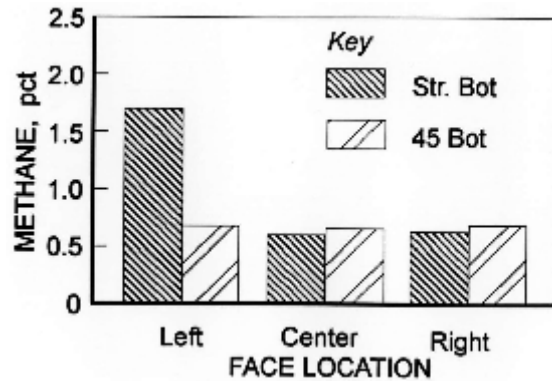

Figure 13. Comparing the effects of straight and angled underboom sprays.

The turbulence created by operating the scrubber and sprays together made it difficult to accurately determine face airflow direction. However, when the sprays and scrubber were used together intake air moved up the curtain side of the entry and back the return side of the entry. It is likely, therefore, that using top sprays and the scrubber together results in face airflow that moves from the intake to the return side of the face. Top sprays angled 30° toward the return side of the face created a spray pattern that interfered less with face air flow pattern than the top straight sprays. This resulted in lower face methane levels.

Water sprays have a greater effect on face airflow patterns when exhaust ventilation is used because the face air velocities are generally lower than with blowing ventilation. When sprays are used with blowing face ventilation and a scrubber, the water sprays influence air flow primarily within 3 or 4 ft of the face. Although they can have a significant effect on re-distributing the gas at the face, the sprays have less effect on moving methane out of the face area.

Cutting drum height affected methane levels. For the conditions tested, which included a uniform release of methane at the face, methane levels were

highest when the drum was up. When the drum is up most of the water impacts the roof and the spray has less of an effect on face airflow. Most tests were conducted with the drum up because concentrations were higher. Methane levels were lowest when the drum was at the middle height. With the drum at the middle the sprays move more air.

When used with top 30° sprays, underboom sprays, which are primarily used for dust control, created air flow turbulence that interfered with airflow movement across the face. The result was that face methane levels increased on the left side of the face. Adding side sprays improved airflow across the face and reduced methane levels. Angling the underboom sprays toward the return side of the entry also helped to reduce turbulence and reduced methane levels.

The conditions tested were designed to simulate face ventilation during mining of a box cut using blowing ventilation. Methane concentrations measured in an operating mine will vary depending on the actual operating conditions and the methane liberation rate in the face area. The results obtained provide guidelines for selection and use of water spray systems for use in improving face airflow and reducing methane concentrations at the face.

The guidelines are designed to reduce methane in the face area using water sprays and scrubbers, but will not necessarily reduce dust generated at the face by the mining operation. Water sprays increase turbulent airflow at the face that can improve dilution of methane with available intake air. Turbulent flow can increase dust levels if it creates excessive dust rollback. In some situations the use of a particular water spray system can reduce the collection efficiency of scrubbers by causing the dust to bypass the scrubber inlets. Studies to evaluate the effect of water sprays on dust and water for the same range of operating conditions are planned.

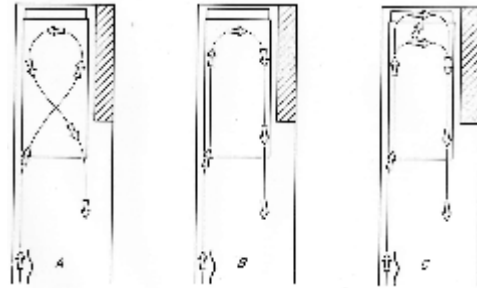

Figure 14. Face airflow patterns for (A) no water sprays or scrubber, (B) scrubber only, and (C) water sprays only.

REFERENCES

- Taylor, C.D., Rider, J. and Thimons, E.D. 1996, "Changes in Face Methane Concentrations Using High Capacity Scrubbers with Exhausting and Blowing Ventilation," Proceedings of the SME Annual Meeting, Preprint 96-167, Phoenix, AZ, March 11-14, 5 pp.
- Thimons, E. D., Taylor, C. D., and Zimmer, J. A., 1999, "Ventilating the Box Cut of a Two-Pass 40 ft Extended Cut," Journal of the Mine Ventilation Society of South Africa, Vol. 52, No.3, July/Sept., 108-115 pp.
- Volkwein, J. C., Ruggieri, S. K., McGlothlin, C. and Kissell, F.N., 1985, "Exhaust Ventilation of Deep Cuts Using a Continuous-Mining Machine," Bureau of Mines Report of Investigation No. 8992, 16 pp.
- Volkwein, J. C., Thimons, E.D., and Hallfinger, G., 1985, "Extended Advance of Continuous Miner Successfully Ventilated With a Scrubber in a Blowing Section," 2nd US Mine Ventilation Symposium, Reno, NV, Sept 23-25, pp. 741.
- Volkwein J C., and Wellman, T.S., 1989, "Impact of Water Sprays on Scrubber Ventilation Effectiveness," Bureau of Mines Report of Investigation No. 9259, 12 pp.