

## INVESTIGATION OF THE JACKING FORCE CAPABILITY OF TUNNEL LINERS

Thomas M. Barczak  
NIOSH  
Pittsburgh, PA

Ron Smith  
American Commercial Inc.  
Bristol, TN

### ABSTRACT

Steel liner plates, which are bolted together to form a shell, are commonly used to provide temporary protective linings in the tunneling industry to ensure the stability of the tunnel and safety of the workers until more permanent ground reinforcement can be installed. As the ground deforms to try and close the opening, the liner plate is radially stressed, and by deforming redistributes these loads back to the surrounding insitu earth. Grouting behind the plates is done to fill any voids and ensure uniform contact to the strata around the back of the plates. Another function of the liner plate in some applications is to act as a platform or structure for the mining machine to react against in order to develop the necessary forward thrust to be able to excavate the face. In this case, the liner plates are loaded axially as a horizontal column of bolted liner plate rings, creating a jacking force against the liner plate assembly. In general, the buckling strength of the plate sections determines the jacking force capacity. Historically, the jacking force capacity of tunnel liner plates has been theoretically determined by some simplistic equations developed from tests of single liner plates. Recently, full-scale tests on a complete circular section of bolted liner plate ring segments have been conducted in the NIOSH Safety Structures Testing Laboratory using the unique Mine Roof Simulator to apply controlled loading in a manner that simulates the real world environment. Due to the unique size and capacity of the Mine Roof Simulator, these are believed to be the first full-scale tests conducted on the jacking force capability of tunnel liner plate rings. These tests indicate that the previously used theoretical equations tend to over predict the jacking force capacity of these tunnel liner plates. Unanticipated deformations in the field have been observed at loads below these theoretical design loads, therefore, a more accurate determination of the jacking force capability was needed. This report summarizes the full-scale test results, examines design parameters that impact the jacking force capability, and develops new mathematical models to improve the prediction of design loads.

### INTRODUCTION AND BACKGROUND INFORMATION

Tunnel liners can be any number of materials, which are used to prevent the ground from collapsing into the working tunnel as it is excavated, providing protection to the workers until more permanent reinforcement can be installed. Steel liner plate such as that evaluated in this study (figure 1) is a very effective material since it can be bolted together from inside the tunnel to form a contiguous structure of required diameter as the tunnel is advanced.

The research pertaining to this paper is the result of a request from American Commercial Inc in Bristol, VA to conduct

full-scale testing of tunnel liner plates in the unique NIOSH Mine Roof Simulator. American Commercial Inc and its predecessor company Commercial Shearing Inc have been a major manufacturer of roof support products for tunnels for the past 75 years. Their first installation of steel liner plates dates back to 1926 in the Moffat Tunnel in Colorado, which at the time was declared the year's outstanding engineering achievement (1). Since then, American Commercial has become a world leader by being involved in thousands of tunneling projects on six different continents.



Figure 1. Steel liner plate commonly used to provide temporary lining of tunnels.

During the past year, structural damage was noticed on several tunnel liner plates in one tunneling operation (see figure 2). These deformations were unexpected in that the design calculations predicted a capacity significantly larger than the estimated 240 tons of load in this particular application. These deformations prompted American Commercial Inc to study the problem to determine if: the theoretical calculations upon which the loading capabilities were based were in need of modification, the load conditions were different than estimated, or if there were quality control problems with the fabrication of these particular

liner plates. It was concluded that the best way to examine this problem would be to conduct full-scale testing.

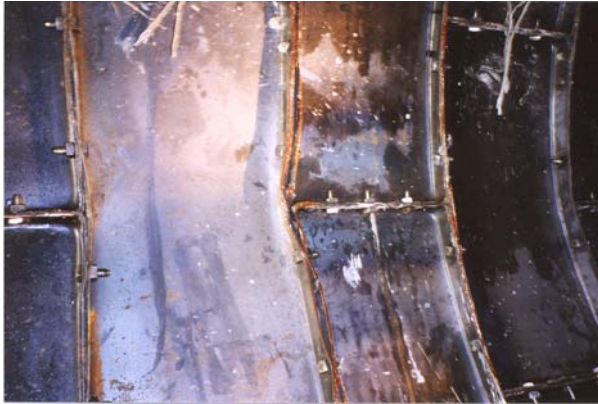

**Figure 2. Damage to liner plates in one tunneling application at an estimated jacking load of 240 tons.**

The Mine Roof Simulator is large biaxial load frame that is designed to simulate the weight and movement of overburden rock masses in underground mining so that support structures can be analyzed in a controlled load environment (see appendix A). It has a load capacity of up to 3 million pounds of vertical force through a 24-inch displacement. In addition to providing controlled convergence of the roof and floor, horizontal displacements of up to 16 inches can be provided to induce shearing type loading with capacities of up to 1.6 million pounds. The goal of this project was to load a series of tunnel liner plate rings configured in a 9-ft diameter in compression to simulate the jacking force induced on the liner plate assembly by the tunnel boring machine. These dimensions are equivalent to that used in the field application, where excessive deformation of the liner plate sections occurred, so a meaningful comparison of the laboratory results and field experiences could be achieved. Figure 3 shows one configuration of the tunnel liner section being installed in the load frame in preparation for testing.

This paper describes the full-scale tests that were conducted and the results of these tests relative to objectives of the study. Included in the study were liner plates with and without gasket material, which is used to prevent water infiltration into the tunnel, blocking material, which is normally specified to stiffen the liner plate for axial loading, and variations in the turning radius of the liner plate edges. This was the first full-scale testing of liner plate rings conducted by American Commercial Inc and it is believed to be the first ever tests conducted to this scale by anyone. The tests proved to provide valuable information pertaining to the

failure mode of liner plate subjected to axial loading and the significance of blocking material in controlling this failure mode. It was concluded that the previous theoretical calculations of jacking load capacity, which were based on single liner plate testing as opposed to full ring segments, did not accurately predict the capabilities of these structures as used in the actual tunnel application. From the full-scale tests, new mathematical models would be developed to improve the load capacity prediction and design requirements for tunnel liner plate applications. Hence, an improvement in the state-of-the-art of tunnel design providing increased safety to the workers has been achieved through these full-scale tests..



**Figure 3. Four layer section of liner plate being constructed in the Mine Roof Simulator for full-scale testing.**

### **FUNCTION OF TUNNEL LINER PLATE**

In general, liner plates can provide two basic functions in tunneling operations. In conventional tunneling methods where tunnels are excavated by full face, heading and bench, or multiple drift procedures, these tunnel liners are used to stabilize and prevent infiltration of surrounding material, whether it be soil or rock, into the tunnel and in so doing provide protection to the workers and to secure the area for more permanent lining of the tunnel, usually by concrete, if necessary. The steel liner plate is fabricated to bolt together to form a complete or partial circle of protection. As the ground deforms, the liner plate is actively loaded and deflects in response to the ground pressure. However, as the tunnel liner deflects it then transfers the active ground loading back into surrounding areas of the ground, which is now acting as a passive restraint to the tunnel liner deformations. This concept is illustrated in figure 4. Here it is shown that as overburden material vertically loads the tunnel liner, it deflects inward at the top and outward at the sides. The ground resists the outward deflection of the sides of the liner plate by developing a passive force equal in magnitude and opposite in direction to the force exerted by that of the lining (figure 4).

The ability of the surrounding ground to resist the outward bulge of the liner plate ring is the key to vertical load support induced by the weight of the rock or soil above the tunnel. With the ring confined to a small deflection, the thrust line induced by the load is forced to follow the ring of liner plates. Thus, the ability of the assembly to withstand the applied load depends upon its

ability to transmit radial ring thrust from plate to plate around the ring without inducing high bending stresses that would cause the liner plate to buckle. Hence the design criteria to control the surrounding ground for the tunnel liner plate are clear (1).

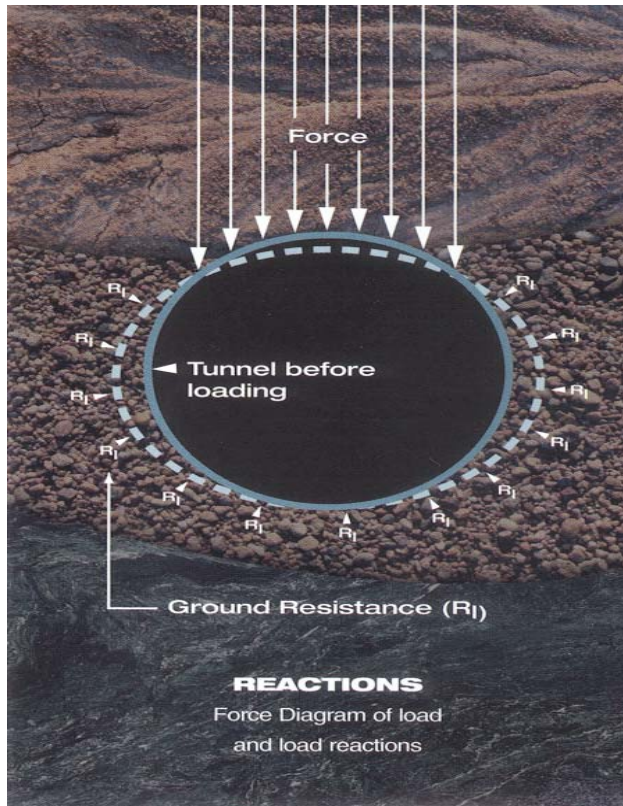
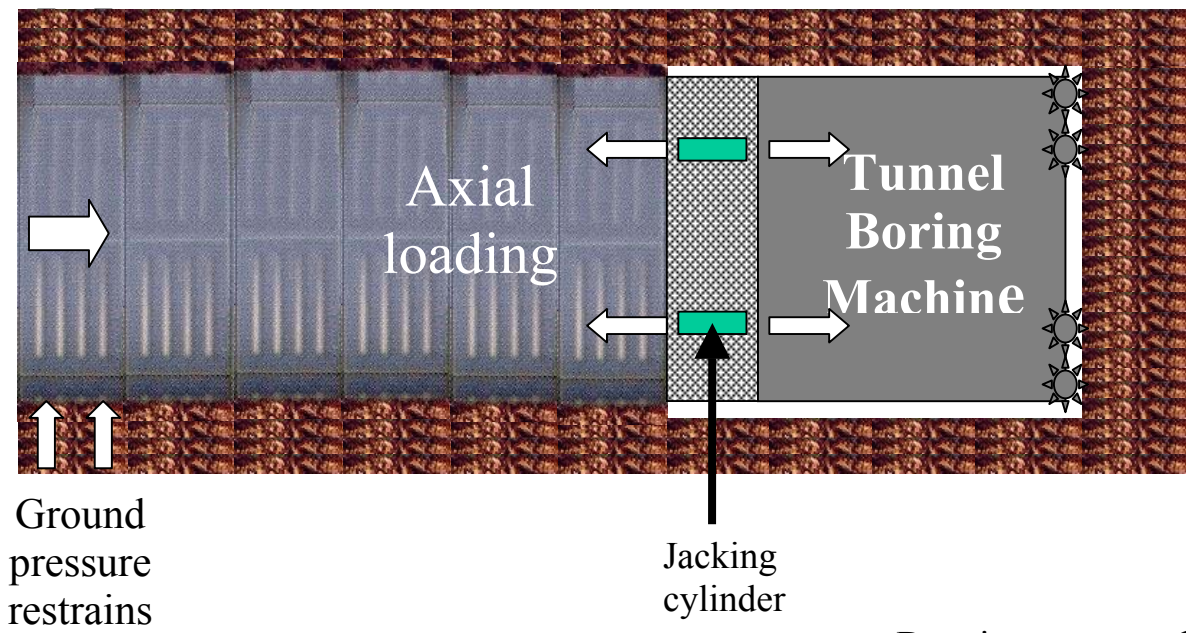

Figure 4. Function of tunnel liner to control ground pressure by distributing loads back into the surrounding ground.

- Deflection Criteria -- First, it is imperative that the tunnel dimensions be controlled to limit the liner plate deflections such that the thrust line is maintained within the liner plate assembly. Typically, deflection should remain within 3% of the nominal diameter. If the tunnel is over-mined or the soil or rock is unstable and unable to maintain the shape of the original opening, the tunnel is typically grouted or filled with some form of fill material to maintain the ground presence needed to redistribute the active liner plate loading back into the ground.
- Minimum Stiffness – The stiffness of the liner plate assembly is an important parameter because it defines how much the liner plate will deflect under load, and as previously described it is imperative that the liner plate be able to maintain its structural stability to transmit active loading through deflections elsewhere within the assembly back into the ground. The minimum stiffness requirements depend on the type of liner plate used. The minimum stiffness requirements as published by the American Association of State Highway and Transportation Officials (AASHTO) and the American Railroad Engineering and Maintenance of Way Association (AREMA) is 111 lbs/in for four-flange liner plate
- Critical Buckling Criteria – For the liner plate to function as designed where the thrust line is maintained within the liner plate assembly, each liner plate is subjected to compressive stresses along the length of the plate. Hence, the buckling strength of the liner plate is a critical design parameter, since if the buckling strength was exceeded, the liner plate would weaken and no longer be capable of carrying the thrust associated with the active ground loading. The buckling strength of the liner plate is a function of the cross-sectional area of the liner plate, the moment of inertia and radius of gyration of the plate, and the modulus of elasticity for the steel. The design for buckling is accomplished by limiting the ring compression thrust to the buckling stress, not to exceed 28,000 psi or the yield strength of the steel, multiplied by the effective cross-section area of the plate



Drawing not to scale

Figure 5. Diagram of axial loading of tunnel liner plate due to jacking forces associated with advancement of the miner.

(which is generally considered as only 50% of the actual area) with an additional factor of safety of 2 built into the design. Hence, the allowable thrust is well below that which should cause buckling of the tunnel liner plate.

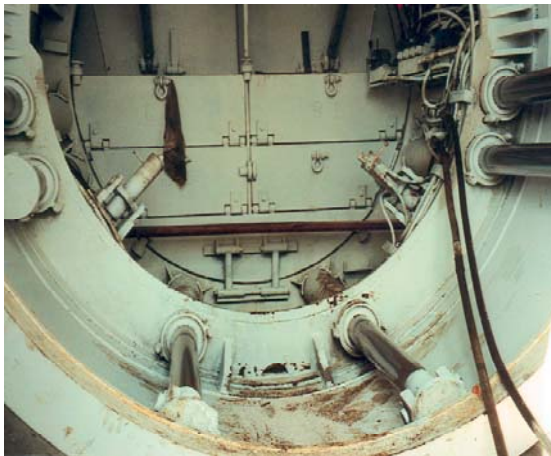

**Figure 6. Photo showing tunnel boring machine equipped with jacking ring to uniformly transfer jacking loading into the tunnel liner.**

- **Joint Strength** – The seam strength of the liner plates must be sufficient to withstand the thrust from the total load supported by the liner plate. Tables of joint strength, measured in kips/ft for different plate thickness, are available from the above-mentioned specifications. A factor of safety of 3 is typically employed in determining the joint strength, meaning that the actual joint strength is at least 3 times that of expected loading.

The second function of liner plates is to act as a reactionary platform or structure upon which certain types of tunnel boring machines thrust against to develop the necessary force at the cutting head or to steer the cutting head in the desired direction during the excavation of the tunnel (figures 5 and 6). It is this function of the liner plate that was investigated in the full-scale laboratory tests conducted as part of this study.

Thrust is provided by a set of hydraulic rams, which exert force against the stationary liner plate being held in place by the ground reactions described above. A jacking ring or solid steel ring is typically placed immediately behind the boring machine to enable the jacking forces to be uniformly applied to the subsequent rings of liner plate. It is normal to dissipate thrust loads due to the jacking forces within the first 50 feet of the tunnel lining as long as the annulus is grouted or backpacted.

The allowable jacking force is again calculated based on the buckling strength of the bolted liner plate rings, except the loads are now applied axially along the direction of the tunnel excavation instead of radially through the circumference of the liner plate ring as would occur from the ground loading. Traditionally, computing the buckling strength of the flanges where the liner plates are bolted together, and adding the load carrying capacity of the skin of the liner plate in between the flanges have calculated the jacking capacity of the liner plate assembly. Several assumptions about the effective width of the flange and the maximum stress in the skin portion of the plate between the stiffeners were typically made in these computations. In order to clarify these variables, which are critical in the determination of jacking thrust capability, a series of tests on single and three-section liner plates was conducted in 1973 by Commercial Shearing Inc in cooperation with Youngstown State University. These results are reported in the next section.

#### LINER PLATE TESTS CONDUCTED AT YOUNGSTOWN STATE UNIVERSITY

Two tests to evaluate the jacking capability of steel tunnel liner plate were conducted in this unpublished study in 1973. The first test was conducted on a single liner plate and the second was conducted on three plates bolted together as shown in figure 7. The liner plates were instrumented with strain gages in an attempt to measure the stress profile the across the liner plate. A load of 50,000 lbs in the first test and 25,000 lbs in the second test was applied in 5,000 lbs increments uniformly to the liner plate section(s) by a Forney Compression Testing machine. The goal was not necessarily to test the plates to failure as much as to determine the load transfer among the plate skin, flange, and stiffening members.

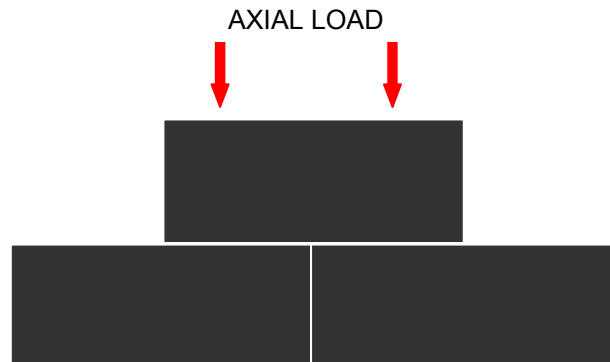

**Figure 7. Three-segment test conducted at Youngstown State University in 1973.**

The results of the three-section liner plate test revealed that the stress in the skin of the plate reached an average value of about 10,000 to 15,000 psi and more or less remained constant. This indicates that the skin of the plate was buckling elastically and that the load was then being transferred from the plate skin to the stiffeners and/or the plate flanges. Based on this test, the 10,000 psi stress in the skin plate was used to calculate the expected jacking force capacity of the liner plate. Prior to this study, the full yield strength of the plate (i.e., 28,000 psi) was erroneously used in calculating the contribution of the non-reinforced skin of the liner plate to the overall jacking force capacity, resulting in an estimated capacity that was considerably higher than the plate could actually carry since the buckling of the plate was ignored.

Another outcome of these initial tests was a revision in the way that the effective width of the flange section was calculated. Previous methods for determining the effective width came from studies conducted by the Navy on submarine hulls. They recommended using  $1.57 \times \sqrt{r \times t}$  where r is the radius of the hull (or liner plate in this case) and t is the thickness of the plate. It was concluded from this test and other tests conducted by Commercial Shearing Inc that a more reasonable value for the effective width ( $W_e$ ) could be found by the following equation.

$$W_e = \frac{t}{\sqrt{3(1-\nu^2)}} \times \sqrt{E/F_y}$$

Where t = thickness of liner plate, inches

$\nu$  = Poisson ratio = 0.3

E = modulus of elasticity,  $29 \times 10^6$  psi

$F_y$  = yield strength of the steel, psi

Based on this work, the estimated jacking force of a full set of liner plates could be theoretically calculated. Here is an example for a non-reinforced liner plate using 5-gage plate sections constructed in a 9-ft diameter assembly requiring 9 liner plate sections to form a full circle ring segment. Note that this also assumes the plates are manufactured with the flanges at exactly 90° and ignores the corner radii and the effect of the holes in the flanges.

1. Calculate the effective width of the bolted flange section.

$$W_e = \frac{0.2092}{\sqrt{3(1-0.3^2)}} \times \sqrt{\frac{29 \times 10^6}{28 \times 10^3}} = 4.0794 \text{ inches}$$

2. Calculate the strength of the bolted flange section as follows (figure 8):

- Determine the neutral axis for the flange section.

Area of top section ( $A_1$ ) =  $(0.2092) \times (1.8305) \times 2 = 0.7659 \text{ in}^2$

Area of bottom section ( $A_2$ ) =  $(0.2092) \times (1.9158) \times 2 = 0.8016 \text{ in}^2$

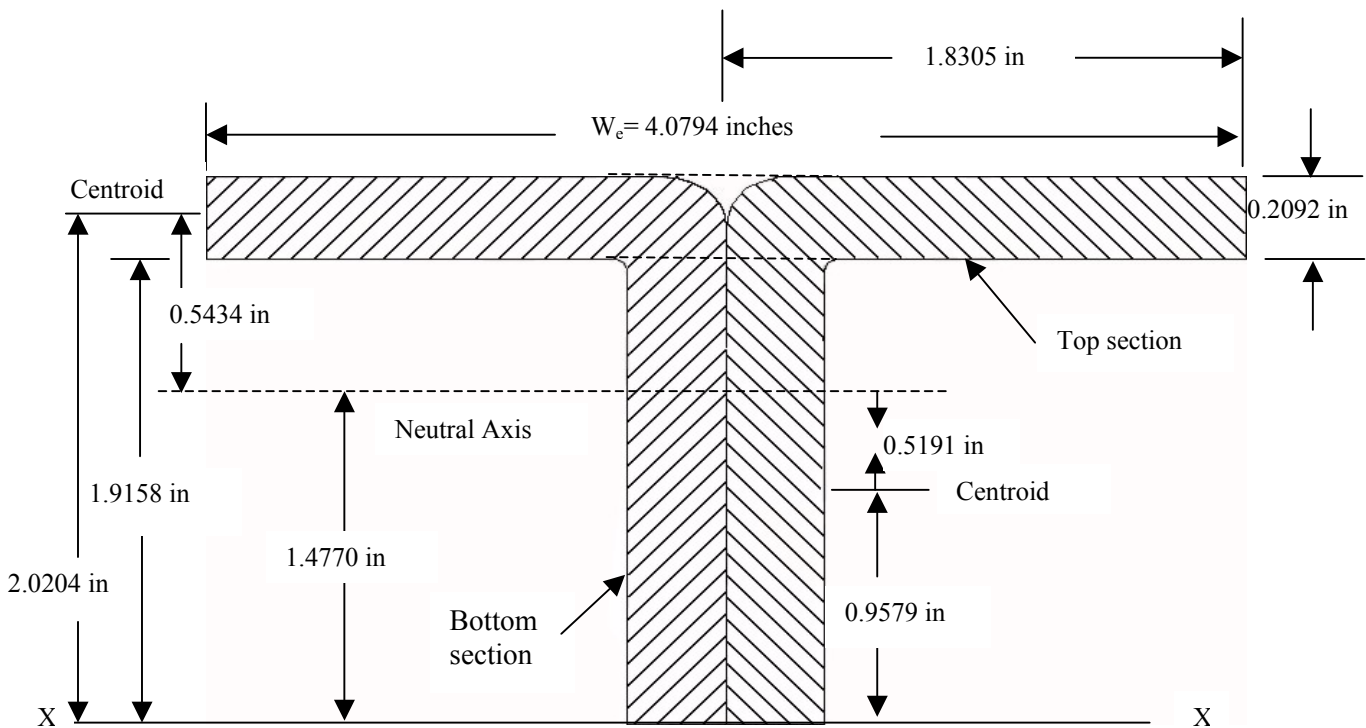

Figure 8. Diagram of bolted flange section at ends of liner plate sections.

Moment arm to centroid of top section from X – X axis – (Y<sub>1</sub>) = 2.0204 in

Moment arm to centroid of bottom section from X – X axis – (Y<sub>2</sub>) = 0.9579 in

Neutral axis is computed from (A<sub>1</sub> + A<sub>2</sub>)  $\bar{y}$  = A<sub>1</sub>y<sub>1</sub> + A<sub>2</sub>y<sub>2</sub> as follows:

$$(0.7659) + (0.8016) \bar{y} = (0.7659 \times 2.0204) + (0.8016 \times 0.9579)$$

$$\bar{y} = \text{Neutral Axis} = 1.4770 \text{ inches}$$

- Moment of inertia – The moment of inertia is computed by dividing the bolted flange section in two areas: (1) the top two pieces of the flange which are in the same plane as the skin of the liner plate and (2) the two perpendicular sections which form the flange arrangement. The moment of inertia is computed using the parallel axis theorem as follows:

$$I_{\text{Total}} = (I_1 + A_1 d_1^2) + (I_2 + A_2 d_2^2)$$

$$I_1 = \frac{1}{12} \times b \times h^3 = \frac{1}{12} \times 1.8305 \times 0.2092^3 \times 2 = 0.0028 \text{ in}^4$$

$$I_2 = \frac{1}{12} \times b \times h^3 = \frac{1}{12} \times 0.2092 \times 1.9158^3 \times 2 = 0.2452 \text{ in}^4$$

$$d_1 = 0.5434 \text{ in}$$

$$d_2 = 0.5191 \text{ in}$$

$$I_{\text{Total}} = (0.0028 + 0.7659 \times 0.5434^2) + (0.2452 + 0.8016 \times 0.5191^2) = 0.6902 \text{ in}^4$$

- Compute the radius of gyration (r) from the moment of inertia (I<sub>Total</sub>) and the area (A) of the flange section.

$$r = \sqrt{\frac{I_{\text{Total}}}{A_1 + A_2}} = \sqrt{\frac{0.6902}{1.5675}} = 0.664 \text{ in}$$

- Assume the flanges act as columns and calculate the allowable stress using column formulas from A.I.S.C. specifications (2):

$$C_c = \sqrt{\frac{2 \times \pi^2 \times E}{F_y}} = \sqrt{\frac{2 \times (3.1416)^2 \times (29 \times 10^6)}{28,000}} = 143.0$$

A pinned end condition is assumed resulting in k= 1.0.

$$\frac{(k \times L)}{r} = \frac{1.0 (16 - 0.2092 - 0.2092)}{0.664} = 23.4663$$

Since  $\frac{(k \times L)}{r} < C_c$ , the following equation from the A.I.S.C. is used to compute the allowable stress (F<sub>a</sub>) in the flange section (2):

$$F_a = \frac{F_y \left( 1 - \frac{\frac{1}{2} \times \left( \frac{k \times L}{r} \right)^2}{C_c^2} \right)}{\frac{5}{3} + \frac{3}{8} \left( \frac{k \times L}{r} \right) - \frac{1}{8} \left( \frac{k \times L}{r} \right)^3} =$$

$$\frac{28,000 \left( 1 - \frac{\frac{1}{2} \times 23.4663^2}{143^2} \right)}{\frac{5}{3} + \frac{3}{8} \times \frac{23.4663}{143} - \frac{1}{8} \times \frac{23.4663^3}{143^3}} = 15,988 \text{ psi}$$

$$\text{Flange Load} = \text{Area of flange} \times \text{stress} = \frac{1.5675 \times 15988}{2000} = 12.53 \text{ tons}$$

- Compute the load carried by the skin of the plate section using the assumption that the stress is 10,000 psi.

$$\text{Plate Load} = \text{Area} \times \text{Stress} = (37.6875 - 4.0794) \times 0.2092 \times 10000 = 70,307 \text{ lbs} = 35.2 \text{ tons}$$

- The total load for a nine plate ring segment would be:

$$\text{Jacking Load Capacity} = \text{Flange Load} + \text{Skin Load} = (9 \times 12.53) + (9 \times 35.2) = 429 \text{ tons}$$

### FULL-SCALE TESTS CONDUCTED AT NIOSH

The first full-scale tests of an assembled tunnel liner from bolted plate sections were conducted at the NIOSH Mine Roof Simulator (MRS) facility in Pittsburgh, PA in December of 2000 and January of 2001. The goals of the test program were: (1) to compare the full ring assembly tests with previous test results conducted on only single plate sections, (2) to evaluate the impact and failure mode of liner plate with and without reinforcement, and (3) to use this data to refine the methodology for theoretical calculation of expected jacking load capacity for various liner plate constructions.

The test program consisted of testing variations of a 9-ft diameter assembly of 5-gage liner plate with plate sections measuring 37.6875 inches in length and 16 inches in width. A total of six tests were conducted, three tests on a single ring of liner plate forming a 9-ft diameter assembly (see figure 9), and three tests conducted on a stack of four, 9-ft-diameter ring segments as shown in figure 10. The parameters evaluated in the study included: (1) reinforcement of the plate ranging from no reinforcement to wood timbers to 3-inch steel channel, (2) sealing material around the perimeter of the plate including either gasket material or no sealing material, and (3) the flange radius which was either standard or a tight radius. The test arrangements and peak loading observed for each configuration are summarized in table 1. Axial loading of the tunnel liner assembly was provided through a controlled axial displacement at a rate of 0.5 inches per minute by the load frame. Load-displacement profiles for all tests are provided in Appendix B.

**Table 1. Test configurations and measured peak loading for full-scale tests in the MRS**

Test Identification	Perimeter Material	Ring Sections	Reinforcement Material	Flange Radius	Peak Load, tons
Tunnel Liner #1	Gasket	4	None	Standard	287
Tunnel Liner #2	Gasket	4	3x6x16-in oak timbers	Standard	325
Tunnel Liner #3	Plate	4	3x6x16-in oak timbers	Standard	360
Tunnel Liner #4	Plate	1	None	Standard	332
Tunnel Liner #5	Plate	1	3-inch steel channel	Standard	765
Tunnel Liner #6	Plate	1	None	Tight	360

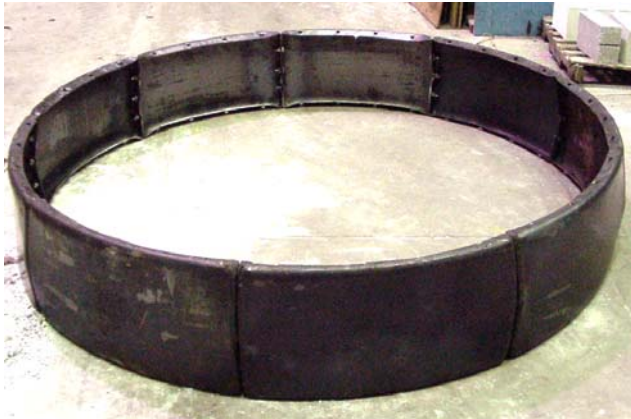

**Figure 9. Single layer test of 9-ft diameter ring of tunnel liner plate (test conducted at NIOSH Mine Roof Simulator facility).**



**Figure 10. Full-scale test of four-ring assembly of tunnel liner plate in the Mine Roof Simulator.**

The conclusions drawn from this full-scale testing are summarized as follows:

1. The previous methodology based on single liner plate testing significantly over predicts the jacking load capacity of steel liner plate fabrications. Referring to the previous section, a capacity of 429 tons was computed for a non-reinforced liner plate assembly using the assumption that the full skin of the liner plate carries a stress of 10,000 psi. The full-scale tests show an axial load capacity ranging from 287 to 360 tons. This compares favorably from observations made in the field, where jacking forces of approximately 240 tons on a non-reinforced liner plate assembly caused deformations indicating that the capacity of the liner plate had been exceeded in this application.
2. Full-scale testing is necessary to properly evaluate the load interaction between the rings or layers of liner plates, which are present in the actual construction in a tunnel application. As shown in figure 11, the middle two rings of the four-ring liner plate test structure observed deformations that were not found in the rings that contacted the roof and floor of the load frame or in the single ring test arrangement. The joint or boundary between the layers of rings controls the deformation to a large degree as seen in figure 11. Essentially, the joint arrangement in the four-ring configuration provides a degree of instability that is not present in the single-ring configuration due to manufacturing tolerances and the fastener locations, etc. The axial stiffness of the structure is also significantly different if only a single ring of liner plate is tested (see figure 12).
3. Gasket material does not have a significant effect on the jacking capacity of the tunnel liner plate assembly. The gasket material is relatively soft and deforms quickly under load. One test showed a slight reduction in jacking capacity when the gasket material was used, but it is not certain that the gasket material was fully responsible for this drop (about 10 pct) in capacity.
4. The tight radius on the liner plate does make a small improvement in jacking force capacity. It probably reduces the eccentricity in the load interaction between the liner plate rings.
5. The failure mode is sensitive to the reinforcement used in the liner plate construction. With no reinforcement, the vertical flange where the ends of the plates bolt together is by far the stiffest area, and axial loading is concentrated in this section before and after the remaining skin of the plate buckles. The vertical flange loading damages the adjacent ring as seen in figure 13. This damage probably causes a progression of failure in the skin that eventually causes buckling of the skin and subsequent rotations creating moments about the horizontal joints between ring segments where the plates bolt together. The vertical flanges for the most maintain their structural integrity in this configuration (figures 10 and 12).



**Figure 11. Middle two rings controlled the failure of the four-layer configuration.**

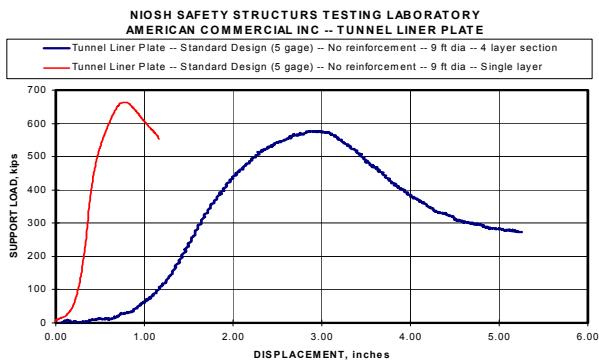

**Figure 12. The axial stiffness of the structure is different if only a single ring of liner plate is tested.**

The use of timber planking changes this failure mode. The timber is stronger than the vertical flange and transfers loading across the skin of the liner plate into the vertical



**Figure 13. Vertical flange loading causes damage to the flange of the adjacent ring.**

flange section in the plate segments above and below. The load is focused on the flange causing the flange to buckle as its strength is exceeded, while there is no apparent damage to the timber planking (see figure 14).



**Figure 14. Timber planking transfer loading and cause damage to the flange area below with no apparent damage to the timber planking.**

The steel channel reinforcement was not tested in the four-ring configuration, but it is likely that the failure mode would be similar to that of the timber-planking configuration previously described. The steel channel, since it is welded to the liner plate skin, should stiffen the plate and increase its load capacity, so the steel channel reinforcement is likely to have a higher jacking load capacity than that of timber planking. The single-ring test produces an artificially high axial loading capability because the channel load is not being transferred into the flanges of the adjacent ring segments. In the single-ring test, the steel channel actually buckles (see figure 15), but again this is not expected to occur in the multi-ring arrangement since the channel



buckling strength is greater than the vertical flange strength and the channel will more than likely transfer load to the adjacent flange without failing itself. It is also seen from the tests that localized failure is occurring in the region near the middle bolthole of the flange (see figure 16), which is reducing the capacity of the flange in this load environment. This type of failure was also observed with the four-ring timber planking test configuration.



Figure 15. Buckling of steel channel in single ring test.



Figure 16. Localized failure occurs near middle bolthole of flange section.

### RECOMMENDATIONS FOR IMPROVING THE THEORETICAL PREDICTION OF JACKING FORCE

It is clear from the full-full-scale tests that the simple model developed as a result of the 1973 testing significantly over predicts the jacking capacity as the predicted load was 429 tons while the measured load for non-reinforced liner plate during the full-scale testing was only 252 tons. Most of the error in this model is likely from over-estimating the contribution of the skin of the liner plate.

The load transfer through a series of liner plate sections resulting from the jacking force of the mining machine is quite complex, more than likely involving complex inelastic buckling and interactions between the various structural sections of which the complete assembly is made and the boundary conditions which control the load development. None-the-less, improvements in the approximation of the jacking capacity can still be made by improving some of the basic assumptions made in the elastic buckling model.

- Non-Reinforced Liner Plate – The non-reinforced liner plate is modeled in three sections (see figure 17): (1) the bolted flange section with its load capacity determined by its buckling strength, (2) a stiffened area adjacent to the flange with an assumed average stress of 10,000 psi based on the previous 1973 study, and (3) the center section which is assumed to buckle elastically.

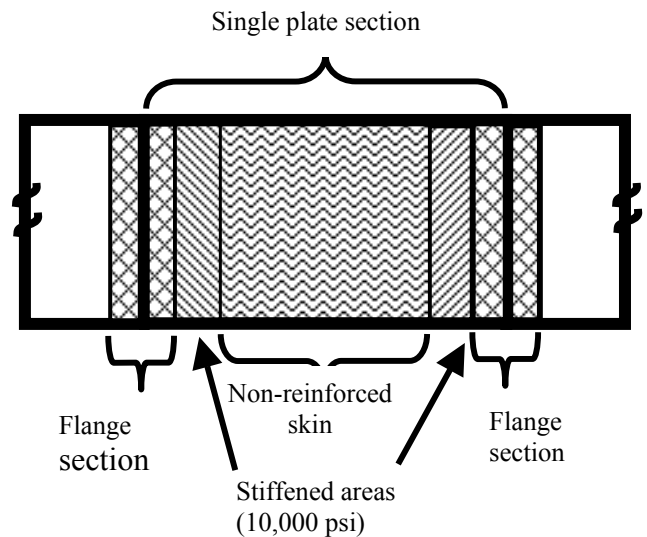

Figure 17. Non-reinforced liner plate is modeled in three sections (flange section, stiffened area, and non-reinforce skin).

- Bolted Flange Section – The capacity of the bolted flange section is computed as shown in the previous section using the A.I.S.C. column buckling equation to compute the buckling stress ( $F_a$ ). Using this equation and the area of the flange section, it was determined that the flange is capable of carrying 12.53 tons of load before it buckles.
- Stiffened Area Adjacent to Flange – It is clear from the tests that the area adjacent to bolted flange section is capable of carrying a higher load than the center section of the plate. The effective width of this stiffened area is assumed to be equal to 1.5 times the effective area of the flange section. Hence, for the 5-gage liner plate, the effective area adjacent to each flange (see previous example) is computed as  $4.0794 \times 1.5 = 6.12$  inches. If it assumed that the average stress across this section is 10,000 psi, then each of the two stiffened sections per liner plate is capable of carrying a load of 6.4 tons.
- Center Section of Plate – The remaining portion of the plate is assumed to buckle. The buckling load is computed using A.I.S.C. specifications. We begin by analyzing a 1-inch wide section of plate. The calculations necessary to compute the buckling load are as follows:

$$\text{Moment of Inertia} = \frac{1}{12} \times b \times h^3 = \frac{(1) \times (0.2092)^3}{12} = 0.000763 \text{ in}^4$$

$$\text{Area} = 1 \times 0.2092 = 0.2092 \text{ in}^2$$

$$\text{Radius of gyration}(r) = \sqrt{\frac{I}{A}} = \sqrt{\frac{0.000763}{0.2092}} = 0.0604 \text{ in}$$

$$\frac{k \times L}{r} = \frac{1 \times (16 - 0.2092 - 0.2092)}{0.0604} = 258.0126$$

$$C_c = \sqrt{\frac{2 \times \pi^2 \times E}{F_y}} =$$

$$\sqrt{\frac{2 \times 3.1416^2 \times 29 \times 10^6}{28000}} = 143.0$$

Since  $\frac{k \times L}{r} \geq C_c$  the following equation is used to compute the buckling stress (2):

$$F_a = \frac{12 \times \pi^2 \times E}{23 \times \left(\frac{k \times L}{r}\right)^2} =$$

$$\frac{12 \times 3.1416^2 \times 29 \times 10^6}{23 \times 258.0126^2} = 2,243 \text{ psi}$$

Plate Load (center section) = Area × stress

$$\text{Plate Load (center section)} = (37.6875 - 4.0794 - (4.0794 \times 2 \times 1.5)) \times 0.2092 \times \frac{2,243}{2,000} = 5.02 \text{ tons}$$

- **Total Load** -- The total load of a 9-ring segment would be the

Total Load = Flange Load + Stiffened Section Load + Center Section Load  
sum of these three components equating to 273 tons.

$$\text{Total Load} = (9 \times 12.53) + (9 \times 2 \times 6.4) + (9 \times 5.02) = 273 \text{ tons}$$

- **Timber Planking Reinforced Liner Plate** – Timber is often used to reinforce the liner plate. The timber is cut to length to fit snugly in between the horizontal flanges of the liner plate and is wedged in place as the liner plate ring is constructed. Since the timber is not fixed to the plate, it does not alter the properties of the plate and functions primarily to transfer the vertical flange loading from the plate above or in front across the liner plate skin and into the flange in the ring below or behind. Hence, the timber is modeled by assuming a load capacity equivalent to that of the steel flange, which was previously calculated to equal to 12.53 tons. However, the test data shows that the flange in this application tended to have localized buckling at the middle bolthole, so only 75% of the flange capacity is used in this computation. Hence, the jacking load capacity for the timber planking reinforced liner plate in a 9-ft diameter section with 5-gage plate is 329.5 tons, computed as the sum of the vertical flange capacity, the capacity of the stiffened area adjacent to the flange, the capacity of the unstiffened area of the plate, and the timber which has an assumed load equal to that of the vertical flange.
- **Flange Capacity** – As previously determined, the flange capacity is computed to be 12.53 tons, which is reduced by 25% due to premature buckling at the bolthole.
- **Stiffened Section of Plate** – As shown above, the stiffened area is assumed to equal 6.12 inches of plate adjacent to each of the two vertical flanges, with each of these areas providing a load capacity of 6.4 tons.
- **Unstiffened Section of Plate** - As shown above, the remaining 21.37 inches of liner plate is expected to buckle at a load of 5.02 tons.
- **Total Load** – This provides a total load from the sum of these components of 329.5 tons.

$$\text{Total Load} = (0.75 \times 9 \times 12.53) + (9 \times 2 \times 6.4) + (9 \times 5.02) + (0.75 \times 9 \times 12.53) = 329.5 \text{ tons}$$

**Steel-Channel Reinforced Liner Plate** – In order to stiffen the plate and improve its buckling strength, a section of channel can be welded to the interior skin of the liner plate, which was shown in figure 14.

Only a single ring of liner plates with 3-inch channel reinforcement was tested. The capacity of this arrangement is computed as above for the non-reinforced plate except the channel strength is now added to the strength of the plate and the entire plate is assumed to be stiffened by the addition of the steel channel. Since the channel is welded to the plate, it is also assumed that the stiffening of the plate by the channel allows the stress to increase to 15,000 psi, which is the maximum measured in the tests conducted at Youngstown State University in the 1973 study.

- **Flange Capacity** – As previously determined, the flange capacity is computed to be 12.53 tons.
- **Stiffened Section of Plate** – The stiffened length of the plate is the section between the flange and the 3-inch-wide channel. With an overall plate length of 37.6875 inches and an effective flange width of 4.0794 inches, the stiffened length of plate is computed as 30.6081 inches. Using the plate thickness of 0.2092 inches, the area of this section of plate is 6.4 in<sup>2</sup>, which translates into a load capacity of 48 tons assuming a stress of 15,000 psi.
- **Channel Capacity** -- For the tests conducted in this study, a C3" x 6# channel section (3 inch wide channel weighing 6 lbs per linear foot) of Grade 50 steel was welded to center

span of the liner plate. The area of the channel is 1.76 in<sup>2</sup>, the moment of inertia is 0.305 in<sup>4</sup>, a column slender ratio limit (C<sub>c</sub>) is 107, and the least radius of gyration is 0.416 in. The buckling stress (F<sub>a</sub>) is then computed from the A.I.S.C. column buckling equation to be 26,184 psi, which translates into a load capacity for the 3-inch channel section equaling 23.0 tons.

- **Total Load** – This provides a total load from the sum of these components of 751.5 tons.

$$\text{Total Load} = (9 \times 12.5) + (9 \times 48) + (9 \times 23.0) = 751.5 \text{ tons}$$

However, in multiple segments where rings of liner plates are butted together, the weakest member will control the failure in the system. It is more likely that the channel will serve the same basic function as the timber planking, acting to simply transfer the loading to the adjacent ring. Hence, a more appropriate model may be that used for the timber planking where the channel is simply modeled with a capacity equal to that of the flange. The only difference would be that the channel stiffens the plate to produce a higher loading than would be expected with the timber planking. The stiffening assumed in this model would be an area adjacent to the flange, just as was done in the timber model, as well as an area adjacent to the channel using the same 1.5 multiplier. Hence the stiffened areas are summarized as follows: (1) 6.12 inches adjacent to the flange providing a load capacity of 6.4 tons and (2) 12 inches in the center section of the plate where the channel is located providing a capacity of 12.6 tons. The remaining 6.37 inches of plate is assumed to be non-reinforced and is modeled with a buckling load capacity of 1.5 tons. In this model, the capacity of the steel channel arrangement would be 410.9 tons.

$$\text{Total Load} = (0.75 \times 9 \times 12.5) + (9 \times 2 \times 6.4) + (9 \times 1.5) + (9 \times 12.6) + (0.75 \times 9 \times 12.5) = 410.9 \text{ tons}$$

### SUMMARY ASSESSMENT

Again, there are many assumptions used in these relatively crude models, which have not been fully evaluated through testing. A more detailed numerical analysis of the plate stress by finite element modeling may produce more accurate models than these presented here, but as the comparison in figure 18 shows, these crude models do provide a reasonable prediction of the tunnel liner jacking capacity and are an improvement over previous theoretical computations.

### CONCLUSIONS AND RECOMMENDATIONS

The Mine Roof Simulator facility at NIOSH provides the capability to conduct full-scale testing of tunnel liners. Full-scale testing of liner plate can provide valuable insight into the capacity and failure mode of these structures, as was observed in the few tests conducted as part of this study. The loads observed in the full-scale tests were consistent with damage and loading that has been observed in the field, hence the tests are believed to provide a valid examination of jacking force capability.

In terms of the jacking force capacity of tunnel liner plate, it is clear from the full-scale laboratory tests that the blocking or strengthening material can make a large difference in both the capacity and mode of failure for these structures. It seems prudent that some form of block material should always be used to enhance the strength of the plate relative to axial loading when the plate is used as a reaction fixture for advancement of the tunnel boring machine. This too is confirmed by field experience. In the one application referenced as the stimulus for conducting this full-scale laboratory study, an unblocked tunnel liner plate

suffered deformation when other field installations using the same plate with reinforcement performed well without any signs of failure. Timber planking is an easy and effective form of blocking. The major problem with timber planking is the inconsistency in spacing of these on site and possible variations in length and retention of the timber planks under fluctuating loads when thrusting. Reinforcement by welding additional steel members eliminates these problems and is generally a more effective solution.

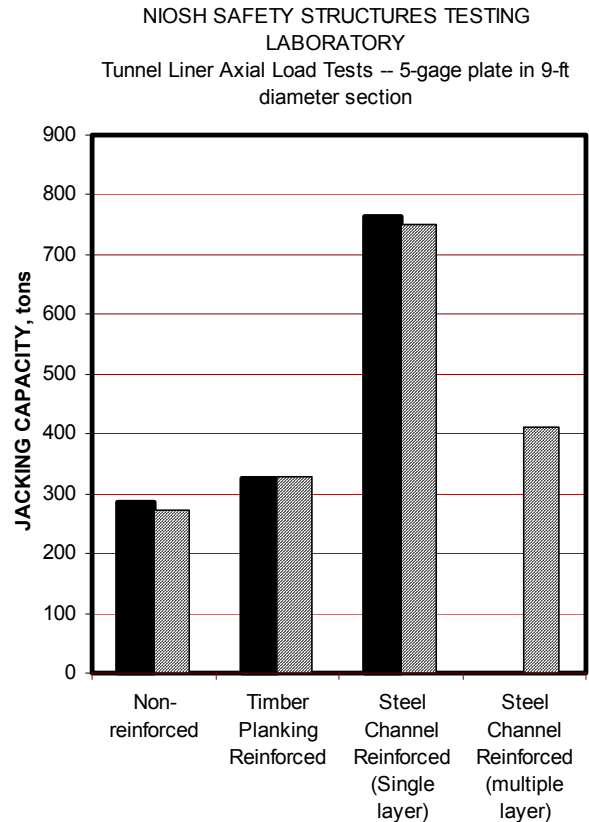

Figure 18. Comparison of test results and predictive models of jacking force capacity.

One of the goals of this study was to improve the theoretical computation of jacking force capacity. Previous computations were largely based on a study completed in 1973 in which only single liner plate sections were tested. These computations tended to over predict the jacking capacity of tunnel liner plate assemblies, most likely by due to poor assumptions made in regard to the buckling of the plate under the loading application. Although the models developed in the current study are still fairly crude with several assumptions made regarding the stress transfer through the liner plate, they are able to reasonably predict the jacking capacity as measured in the full-scale tests conducted under controlled loading in the laboratory using the Mine Roof Simulator load frame. Additional testing is needed to confirm that the models would work equally well with different plate gages, diameters, and fabrications. A finite element analysis of the stress development in a liner plate may also provide valuable information into this issue and should be explored as part of a continuing study of this subject.

From a design perspective, it is clear that the vertical flange is a critical member in providing the required jacking force capacity. It is also seen from the tests that the boltholes, which

allow the plates to be bolted together weaken the vertical flange. The flange strength could be enhanced by eliminating the middle bolthole or enhancing the section modulus in this area to prevent failure in this region and improve the overall capacity of the liner plate assembly in terms of jacking force. The horizontal flange is also important. Strengthening this flange by adding gussets would help to reduce the bending of the flange and reduce the rotation of this joint that contributes to buckling of the body of the plate.

**REFERENCES**

American Institute of Steel Construction, Ninth Edition, 1989, "Manual of Steel Construction: Allowable Stress Design," pp5-42.  
 Proctor, R. V. and White, T. L., 1968, "Rock Tunneling with Steel Supports," Youngstown Printing Company, Youngstown, OH, 291 pp.

**APPENDIX A -- DESCRIPTION OF THE MINE ROOF SIMULATOR LOAD FRAME**

The Mine Roof Simulator (MRS) is a servo-controlled hydraulic press custom built by MTS Systems Corporation to U.S. Bureau of Mines (USBM) specifications. It is designed specifically for longwall shield testing, and is the only active load frame in the United States that can accommodate full-size shields.

A functional diagram of the load frame is shown in figure A-1. The load frame has several distinctive characteristics. The size of the platens is 20-ft x 20 ft. The upper platen can be moved up or down and hydraulically clamped into a fixed position on the directional columns to establish a height for testing. With a maximum vertical opening between the upper and lower platen of 16-ft, the load frame can accommodate the largest shields currently in use. Controlled movement of the lower platen provides load application. The load frame is a biaxial frame, capable of applying both vertical and horizontal loads. Load actuators are equipped with special hydrostatic slip bearings to permit simultaneous load and travel. This allows vertical and

horizontal loads to be applied simultaneously. The capability to provide controlled loading simultaneously in two orthogonal directions is unique at this scale.

A set of four actuators, one on each of the corners of the lower platen provides vertical loading. Loads of up to 3 million pounds can be applied in the vertical direction by upward movement of the lower platen. Each actuator is capable of applying the full 3 million pounds of force, so that the specimen can be placed anywhere on the platen surface and the full 3 million capacity can be provided. The vertical (upward) range of motion of the lower platen is 24 in.

Horizontal loading is also provided by a total of four actuators, with two actuators located on both the left and right side of the load frame just below the floor level. These actuators act in pairs to provide horizontal displacement of the lower platen in either a positive or negative (x) direction, reacting off the corner columns of the load frame. The horizontal range of motion of the lower platen is 16 in.

There is no programmable control of the lower platen in the lateral horizontal axis (y-direction). The load frame has a reactive capacity of 1.6 million pounds in this direction, but loads cannot be applied in the lateral direction. The range of motion of the lower platen in this direction is  $\pm 0.5$  in.

The unstressed reference frame that provides feedback on platen displacements and rotations to the closed-loop control system provides Six degrees of freedom control of the lower platen. Pitch, yaw, and roll of the lower platen are controlled to keep the lower and upper platens parallel during load application.

A shock absorber actuator is positioned on the left and right side of the lower platen. These shock absorbers will control the displacement of the lower platen to less than 0.1 inch in the event of sudden failure of the support specimen. The shock absorber action absorbs energy stored in the load frame so that it is not unintentionally released to the test specimen.

Two hydraulic pumps provide up to 3,000 psi of pressure to the vertical and horizontal actuators during load application. The rate of movement of the lower platen is limited by the 140 gpm capacity of the hydraulic pumps. The maximum platen velocity assuming simultaneous vertical and horizontal displacement is 5.0 in per minute.

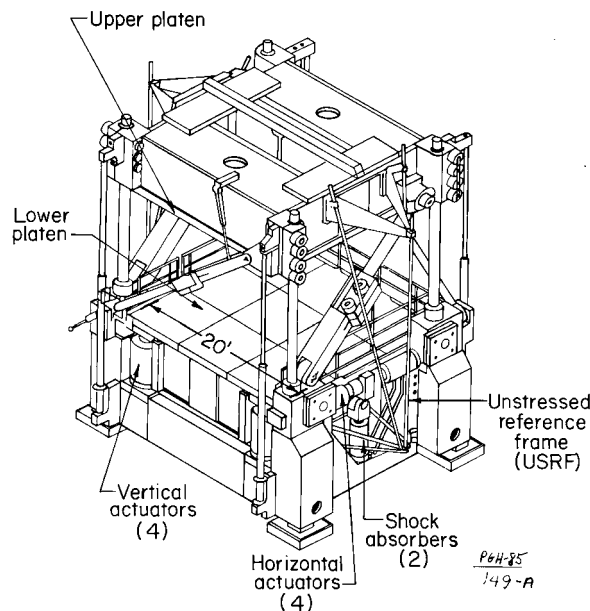

**APPENDIX B – FULL-SCALE LOAD-DISPLACEMENT TEST DATA**

**NIOSH SAFETY STRUCTURES TESTING LABORATORY  
AMERICAN COMMERCIAL INC -- TUNNEL LINER PLATE -- 18 JAN 01**

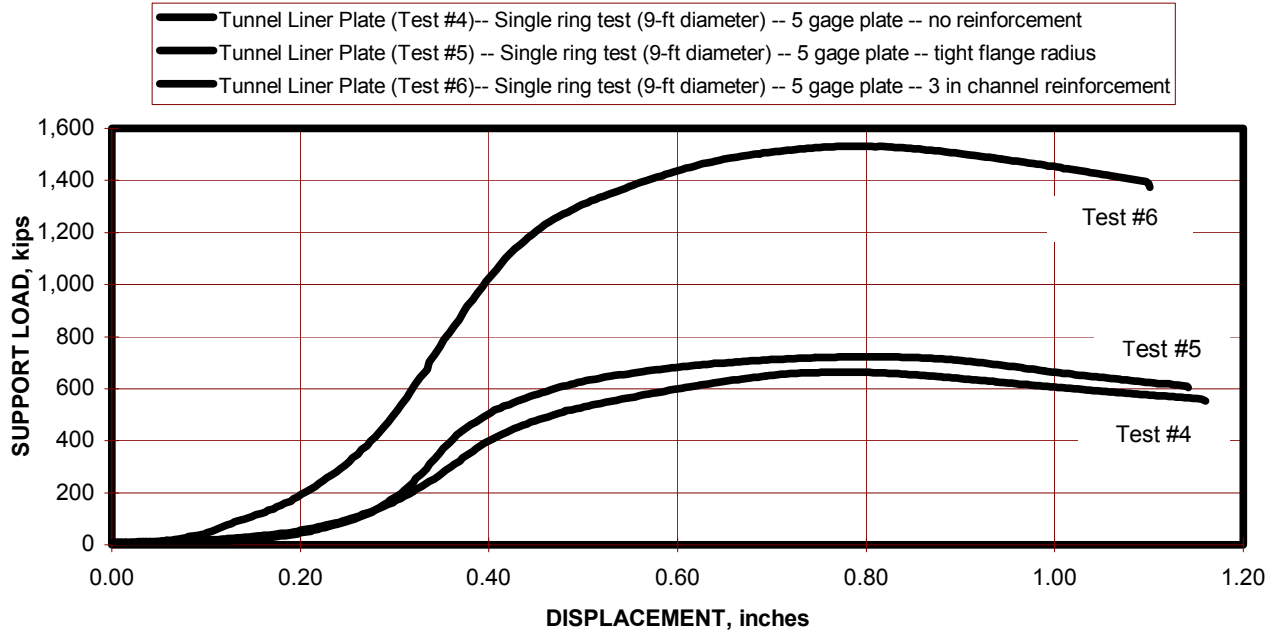

**NIOSH SAFETY STRUCTURES TESTING LABORATORY  
AMERICAN COMMERCIAL INC -- 5-GAGE TUNNEL LINER PLATE -- 6-DEC-2000**

