

RI 9586

REPORT OF INVESTIGATIONS/1995

Evaluation of Smoke Detectors for Mining Use

By John C. Edwards and Gerald S. Morrow

UNITED STATES DEPARTMENT OF THE INTERIOR



UNITED STATES BUREAU OF MINES



U.S. Department of the Interior
Mission Statement

As the Nation's principal conservation agency, the Department of the Interior has responsibility for most of our nationally-owned public lands and natural resources. This includes fostering sound use of our land and water resources; protecting our fish, wildlife, and biological diversity; preserving the environmental and cultural values of our national parks and historical places; and providing for the enjoyment of life through outdoor recreation. The Department assesses our energy and mineral resources and works to ensure that their development is in the best interests of all our people by encouraging stewardship and citizen participation in their care. The Department also has a major responsibility for American Indian reservation communities and for people who live in island territories under U.S. administration.

Report of Investigations 9586

Evaluation of Smoke Detectors for Mining Use

By John C. Edwards and Gerald S. Morrow

**UNITED STATES DEPARTMENT OF THE INTERIOR
Bruce Babbitt, Secretary**

**BUREAU OF MINES
Rhea Lydia Graham, Director**

International Standard Serial Number
ISSN 1066-5552

CONTENTS

	<i>Page</i>
Abstract	1
Introduction	2
Experimental procedures	2
Experimental results	4
Smoke detector response	4
Detector A	4
Detector B	5
Detector C	5
Detector D	5
Detector E	5
Detector F	6
CO measurement	7
Odor measurement	7
Conclusions and recommendations	8
References	9

ILLUSTRATIONS

1. Schematic of the smoke chamber	10
2. Schematic of the sample chamber	10
3. Optical density and response of detectors for smoldering coal combustion	11
4. Optical density and response of detectors for flaming coal combustion	12
5. Response of detector A with respect to optical density for smoldering and flaming coal combustion	13
6. Response of detector D with respect to optical density for smoldering and flaming coal combustion	14
7. Response of MIC with respect to d_{g,n_0} determined from measurements with detector E for smoldering and flaming coal combustion 15	15
8. Measured CO concentration dependence on optical density for smoldering and flaming coal combustion	16
9. Correlation of odor monitor alarm time with time for CO concentration to reach 5 ppm above background for smoldering and flaming coal combustion	17
10. Correlation of odor monitor alarm time with smoke detector C alarm for smoldering and flaming coal combustion	17

TABLES

1. Smoke detector type and sampling mode	3
2. Smoke detector noise and background signal for detectors A to D	6
3. Smoke detector response at optical densities of 0.011, 0.022, 0.033, and 0.044 m^{-1} for detectors A-D	6

UNIT OF MEASURE ABBREVIATIONS USED IN THIS REPORT

cm	centimeter	mV	millivolt
g	gram	pct	percent
m	meter	ppm	part per million
m ⁻¹	inverse meter	s	second
m ²	square meter	V	volt
m ² ·V	square meter volt	V·m	volt meter
mm	millimeter	μm	micrometer

OTHER ABBREVIATIONS AND SYMBOLS USED IN THIS REPORT

a	coefficient, V·m	O _u	percent obscuration per meter, percent/m
b	coefficient, V	S	output signal, V
CO	carbon monoxide	T	
transmission, l		T _o	transmission in clear air, l
D	optical density, m ⁻¹	V _c	charged particle collection
d _g	number mean particulate diameter, m	V _E	voltage in charging region, V
H ₂ S	hydrogen sulfide electrode voltage, V	Y	MIC measurable quantity, l
κ	extinction coefficient, m ⁻¹		
ℓ	optical path, m		
n _o	particulate number concen- tration, particles/m ³		

Reference to specific products does not imply endorsement by the U.S. Bureau of Mines.

Evaluation of Smoke Detectors for Mining Use

By John C. Edwards¹ and Gerald S. Morrow²

ABSTRACT

The U.S. Bureau of Mines has constructed a smoke chamber and developed sensitivity tests for smoke detectors. Response of ionization- and optical-type commercially available smoke detectors have been investigated. Six smoke detectors were measured with respect to visually obscuring smoke characterized by a corresponding optical density for smoldering and flaming coal combustion in the smoke chamber. It was determined that for one type of ionization smoke detector the alarm time was nearly equivalent to that of an odor monitor's alarm for smoldering coal combustion experiments and earlier for flaming coal combustion experiments. The experiments showed that an average CO concentration of 5 ppm corresponded to an optical density of 0.022 m^{-1} for smoldering and flaming coal combustion. Two of the commercially available ionization-type smoke detectors were more responsive to flaming than smoldering coal combustion at an optical density of 0.022 m^{-1} , whereas the optical smoke detectors showed the opposite trend. The responsive characteristics of the detectors evaluated with respect to known smoke conditions in the smoke chamber shows their potential for use as mine fire sensors or part of a mine atmospheric monitoring system to improve mine safety.

¹Research physicist.

²Electronics technician.

Pittsburgh Research Center, U.S. Bureau of Mines, Pittsburgh PA.

INTRODUCTION

In order to evaluate potential mine fire detection systems, it is important to consider not only CO detectors that are currently used in some coal mine conveyor belt entries, but other candidate fire signature detectors. A commonly used fire detector for commercial and residential property is the smoke detector. Its potential for in-mine use has been examined in mines (*J*).¹ In that in-mine evaluation, the detectors occasionally identified conveyor belt heating. Also, for a mine using diesel-powered equipment in which a comparison could be made with CO levels at the time of smoke detector alarm, the smoke detector had a lower frequency of false alarms than CO sensors. More recently, the U.S. Bureau of Mines (USBM) constructed a smoke chamber and developed sensitivity tests for smoke detectors using smoldering and flaming coal combustion (*2*).

The objective of this work is to investigate response to smoldering and flaming coal combustion of several ionization- and optical-type commercially available smoke detectors intended for industrial and in-mine use and to make recommendations for the development of an evaluation procedure for the smoke detectors. The response of the detectors as measured by their analog output signal or manufacturer alarm will be determined with respect to the measurable smoke optical density.

Smoke detectors can be classified into two types based on their operational principle—optical or ionization. Their sampling method will be either diffusion- or pump-controlled. The smoke detectors examined in this report are representative of both types and both sampling methods.

Ionization smoke detectors contain a radioactive source that ionizes the air. The oppositely charged air ions form

a current between two charged electrodes. Diffusion of smoke particulates into the path of the ion current reduces the ion current through attachment of the ions to the smoke particles. This process slows the movement of the ions and thereby increases the ion's probability of recombination. The current reduction is amplified as a measurable signal.

Optical smoke detectors operate on the principle of scattering or absorption of light over an optical path through which the smoke particulates can migrate. For optical scattering, the detector is located to the side of the optical path to measure the amount of light scattered by any smoke particulate present. For optical absorption, the detector is located along the path from the light source and measures the amount of light transmitted without scattering or absorption. Black smoke particulates are more susceptible to optical absorption than scattering.

The standard smoldering and flaming coal sensitivity test procedure for smoke detectors enables the measurement of additional combustion gas products generated within the smoke chamber. In addition to the response of the smoke chamber's photo cell to optical transmission through the smoke and of the measuring ionization chamber (MIC) to smoke particulate size and concentration as described in (*2*), CO and combustion product gas odors were monitored. This provides a benchmark of smoke detector response against CO detection and the previously evaluated odor monitor (*3*) as an early warning fire detector. It was determined from the previous study that an odor monitor alarm time associated with a 1 ppm increase in H₂S above ambient was comparable to the alarm level for one ionization-type smoke detector for smoldering combustion of sulfur-containing coal.

EXPERIMENTAL PROCEDURES

The USBM smoke chamber shown in figure 1 was used in accordance with the procedure established previously (*2*) for a comparative evaluation of smoke detectors. As shown in figure 2, the coal is placed on the heater disc in the sample chamber external to the smoke chamber. Access of smoke to the smoke chamber is limited by the iris setting. The iris settings for smoldering and flaming coal combustion are described in (*2*). Both smoldering and flaming coal combustion sensitivity experiments were conducted. The fuel source for the experiments is 80 g of ground Pittsburgh Seam coal sized to

–9.4 +6.7 mm mesh. CO was monitored with two Ecolyzer Model 4000 CO detectors that sampled combustion product gases from the bottom and top of the smoke chamber. Each Ecolyzer has an internal pump that draws the sample from a line connected to a smoke chamber. A comparison of their values showed the combustion gases in the smoke chamber were well mixed. The CO values were validated against samples drawn into an evacuated glass container from the chamber and subsequently analyzed by gas chromatography.

The six smoke detectors used in the experiments are listed in table 1. Their intended use has been industrial and mining. The type (ionization or optical) and sampling method characteristics

¹Italic numbers in parentheses refer to items in the list of references at the end of this report.

(pump or diffusion mode) are listed. All of the smoke detectors are commercially available, except for detector E.

Table 1.—Smoke detector type and sampling mode

<i>Detector</i>	<i>Sampling mode</i>
Optical type:	
A	Pump.
B	Diffusion.
Ionization type:	
C	Pump.
D	Diffusion.
E	Pump.
F	Diffusion.

The diffusion mode smoke detectors were mounted on the interior shelf adjacent to the air straightener of the smoke chamber in figure 1, and the pump-mode detectors were mounted external to the chamber and sampled from port H. The sample chamber that holds the smoldering or flaming combustion coal sample is shown in figure 2.

Twenty-two combustion experiments were conducted with Pittsburgh Seam coal. Each of the detectors in table 1 were used for a minimum of two smoldering and two flaming coal combustion experiments. Some experiments evaluated more than one detector. Detector C, which has a manufacturer-specified alarm, is a pump type that is expected to assure a prompt response to smoke, and also produces a measurable analog signal in response to smoke concentration. For these reasons, it was used for 16 of the reported experiments to provide a database for comparison with the response of the odor monitor. Because of the experimental configuration of the other detector, it could not be used in every experiment.

The MIC was used in each experiment to provide an ionization-type smoke detection measurement independent of the detector selected. It measures the relative increase of the particles of combustion during each experiment. The MIC measurement and measured optical transmission provide, as discussed in (2), a basis for standardization of smoke chamber smoke particulates. The factors that define a cloud of smoke particulates are particulate diameter, mass or number concentration, and index of refraction.

In order to acquire additional information regarding the comparative detection capability by identification of odor, CO, or smoke, an odor monitor manufactured by Sensidyne (P/N 7016019) was used to sample product of combustion gases from the smoke chamber. The odor meter was used in previously reported research (3) for coal combustion

combustion experiments with 5-cm-diam coal particles as well as mine-size coal particles. The odor monitor responds primarily to aromatic hydrocarbons and, to a lesser extent, to odorless gases and gases classified as simple asphyxiants. Its operating principle is based on the absorption of gas molecules on the surface of a metal oxide semiconductor and the measurable changes in the sensor's electrical conductivity. A component of the product gases of the sulfur-containing Pittsburgh Seam coal is H₂S, which is detectable by the odor monitor in the concentration range from 0.1 to 10 ppm. It is expected that other component product gases will contribute to the odor monitor response. The odor monitor has an internal pump that draws a sample through a line connected to the smoke chamber.

Experimental data were acquired with an analog-to-digital data acquisition system and recorded on a personal computer. The time interval between data samples was 10 s. The error of the data acquisition system was 2.4 mV for a 5-V signal, or 0.048 pct.

A primary instrument for smoke measurement is the optical transmission of visible light through the smoke. Human visibility studies (4) have led to the proposed visibility criterion (5) that a visibility of 10 m corresponds to an optical density of 0.08 m⁻¹. Optical density D is defined in terms of the reduction of light transmission from a transmission T_o in clear air over path ℓ to transmission T.

$$D = - \frac{1}{\ell} \log_{10} \left(\frac{T}{T_o} \right) \quad (1)$$

The optical path length ℓ for these experiments was 1.483 m. A mine fire smoke sensor must detect smoke as early as possible with a maximum exclusion of nuisance alarms. Smoke detector alarm can be characterized by the smoke optical density. Deployment spacing of smoke detectors has been evaluated for smoke optical density as low as 0.011 m⁻¹ (6) for various linear airflows. It was proposed (6) that smoke detectors for underground mines be divided into two classes according to optical density. Accordingly, detectors that alarmed at an optical density less than 0.022 m⁻¹ would be designated Class I detectors, and those that alarm at an optical density greater than 0.022 m⁻¹ but less than 0.044 m⁻¹ would be designated as Class II detectors. These values correspond to human visibilities of 40 m and 20 m, respectively, based on other research (5).

EXPERIMENTAL RESULTS

SMOKE DETECTOR RESPONSE

A total of 12 smoldering coal combustion experiments and 10 flaming coal combustion experiments were conducted.

Figure 3 shows the time-dependent measured optical density and corresponding response for each of the six smoke detectors at least once, for smoldering coal combustion. The advantage of recording the voltage analog signal output for the detectors is the capability to discern early response of the detector to smoke and not be constrained by the manufacturer's designated alarm value. Although the smoke detector response is unique for each detector, figure 3 shows that each of the detectors, with the exception of detector F, shows a measurable response at the inception of a change in the optical density corresponding to a reduction in optical transmission due to absorption and scattering of light by the smoke particulates. Detector F is unique insofar as the output signal is not a continuous rise in response to smoke, but indicates the manufacturer's alarm with a jump in the analog voltage. For each of the smoldering coal combustion experiments shown, the first response to smoke is about 400 s after the heating element in the sample chamber was energized.

Figure 4 shows the time-dependent optical density and response of the smoke detectors for flaming coal combustion experiments. Again, each smoke detector is represented by at least one test result. The response of the detectors, except for detector F, is coincident with a measurable change in optical density, which occurs simultaneously with the opening of the iris between the sample and smoke chambers. As discussed in (2), for flaming combustion tests the iris is opened only after flaming combustion has occurred, by which time smoke production from the heated coal sample has evolved from the smoldering stage to the flaming stage.

Detector A

Detector A is an optical, pump-mode smoke detector with an output signal from 0.1 to 2.8 V. The principle of operation is based on optical scattering of light. The average output voltage that detector A indicates for an optical density of 0.022 m^{-1} is 2.34 V (95 pct confidence interval from 1.96 to 2.72 V) for the eight smoldering coal combustion experiments. The value is 1.33 V (95 pct confidence interval from 0.91 to 1.75 V) for eight flaming coal combustion experiments conducted.

The mathematically smoothed voltage signals of detector A for smoldering coal combustion experiments versus optical density, are shown in figure 5A. The smoothed data correspond to the curves in figure 3A, B, and C. The average slope of the curves is $89.6 \text{ V}\cdot\text{m}$ with a standard deviation of 6.1 in a linear approximation. Figure 5B shows the smoothed data for the flaming coal combustion experiments reported in figures 4A, B, and C. The average slope of the curves in a linear approximation is $54.7 \text{ V}\cdot\text{m}$ with a standard deviation of 4.3. These results indicate detector A is more responsive to smoldering than to flaming coal combustion. For a given smoke optical density produced by smoldering and flaming coal combustion, the detector would have a greater response signal for smoldering than for flaming coal combustion.

The optical transmission through the smoke particulates will be attenuated according to Bouguer's law (7):

$$T/T_0 = e^{-\kappa l}, \quad (2)$$

where κ is the extinction coefficient. The linear relationship between the output signal S for detector A and the optical density, D , can be written

$$S = a D + b, \quad (3)$$

where a and b are constant coefficients. A combination of equations 1, 2, and 3 yields

$$S = \frac{a}{\ln(10)} \kappa + b. \quad (4)$$

Equation 4 shows linear proportionality between S and κ . The extinction coefficient, κ , is proportional to the ratio of the smoke particulate mass concentration to particle diameter or, equivalently, to the product of the smoke particulate number concentration and particle cross-sectional area. Previous research (8) has shown the smoke particle diameter is smaller for flaming than for smoldering combustion. This indicates, based on an increased value of S for smoldering than for flaming combustion for a fixed value of D (or equivalently of κ), that the smoke particulate number concentration is greater for flaming than for smoldering combustion. The larger particulate diameter for smoldering combustion than for flaming combustion could be a contributing factor to the increased detector response to smoldering combustion.

Detector B Detector B is an optical-type, diffusion-mode smoke detector. Extinction of infrared radiation from the optical path reduces the signal at the receiver. This decrease in transmission corresponds to an increase in pct obscuration per meter, O_u . The obscuration per meter is related to the optical density by

$$D = -\log_{10} (1 - 0.01 O_u). \quad (5)$$

Detector B has a range from 0 to 10 pct obscuration per meter. A 10 pct obscuration per meter corresponds to an optical density of 0.046 m^{-1} . The analog signal range for detector B is 0.4 to 2.0 V.

The calibration procedure for detector B required adjustments for a zero, corresponding to clear air transmission, and a span, corresponding to 10 pct obscuration per meter. Errors as large as 15 pct occurred in the calibration of the span. A comparison was made of the optical density based on the optical obscuration measurement in the chamber, and the optical density that corresponds to the expected obscuration per meter based on the analog voltage signal of detector B. For a measured optical density of 0.022 m^{-1} , detector B indicated an average obscuration per meter of 0.78 ± 0.015 pct for two smoldering experiments. This is equivalent to an optical density of 0.0034 m^{-1} . For the two flaming combustion experiments, detector B indicated an average obscuration per meter of 0.62 pct when the optical obscuration meter indicated 0.022 m^{-1} . This corresponds to an optical density of 0.0027 m^{-1} . Detector B did not achieve the maximum output of 2 V corresponding to a 10 pct obscuration per meter for any of the two smoldering or two flaming coal combustion experiments even though for each of the experiments an optical density of 0.08 m^{-1} was achieved. Although the data in figures 3 and 4 show an incipient rise in the detector response coincident with the onset of measurable obscuration, its use as a quantitative instrument is limited.

Detector C

Detector C is a pump-mode ionization detector with a range from 1 to 5 V. The manufacturer-suggested alarm is 2.5 V. A summary of eight smoldering combustion experiments showed the manufacturer-suggested alarm point corresponded to an average optical density of 0.011 m^{-1} and an average CO concentration of 2 ppm above background. For eight flaming coal combustion experiments, the alarm occurred at an average optical density of 0.0072 m^{-1} and an average CO concentration less than 1 ppm above background. This indicates a greater

responsiveness of detector C to flaming than to smoldering coal combustion based on the optical density and CO concentration at which the detector alarms.

Detector D

Detector D is an ionization-type smoke detector that samples smoke through a diffusion mode. The measurable output voltage is shown in figure 3 for smoldering coal combustion, and in figure 4 for flaming coal combustion. There was not a manufacturer-recommended alarm for detector D. Figures 6A and B show a comparison of the output voltage and the optical density for the smoldering and flaming coal combustion, respectively. The data in figures 6A and B are smoothed. The data in figure 6A are for the two experiments reported in figures 3B and D as well as two additional experiments, and the data in figure 6B are for the two experiments reported in figures 4B and D as well as two additional experiments. The initial voltage for detector D in clear air is -0.9 V. The maximum available signal response of the detector to smoke is -0.2 V. Based on four smoldering experiments in figure 6A, the average signal output at an optical density of 0.022 m^{-1} is -0.77 V, and -0.61 V for four flaming combustion experiments in figure 6B. This represents an increase of 19 pct and 41 pct, respectively, over the detector's full-scale range. Figure 6A shows that for the smoldering coal combustion experiments, the output signal is nearly linear with respect to optical density, whereas for the flaming coal combustion experiments shown in figure 6B, the response is nonlinear with respect to optical density. This is in contrast to the optical-type detector, detector A, which showed a linear response for both smoldering and flaming combustion. Also, in contrast to detector A, is the greater responsiveness of detector D, an ionization-type detector, to flaming rather than to smoldering combustion. This is associated with detector D's nonlinear response to flaming coal combustion.

Detector E

Detector E is a prototype ionization-type, pump-mode detector developed by the USBM (9). There are two measurable output voltages associated with the detector, V_E and V_C . V_E is the voltage in the charging region, and V_C is the charged particle collection electrode voltage. In clear air, V_E is about 1.5 V and V_C is about 0.0 V. During the response to smoke, V_E decreases and V_C increases. Figures 3D and 4D show the response of the detector's output voltages for smoldering

and flaming combustion. A theoretical evaluation of the output voltage based on theory, results in a computation of the product of the smoke particulate number concentration, n_p , and the number mean particle diameter, d_p . A comparison was made of the quantity, Y , calculated from the MIC output voltage with the product, $d_p n_p$. Figure 7A shows the comparison corresponding to the smoldering coal combustion, and figure 7B shows the comparison for the flaming coal combustion experiments. There is a near linear relationship between Y and $d_p n_p$. The slope for smoldering combustion is $0.26 \times 10^{-4} \text{ m}^2$ per particle; for flaming combustion it is $0.15 \times 10^{-4} \text{ m}^2$ per particle. As previously noted (2), Y is proportional to the number concentration n_p .

The smoke number average particulate diameter can be calculated from the model equations for detector E. A calculated smoke particulate average diameter for the data points for the smoldering coal combustion case shown in figure 7A is $0.45 \mu\text{m}$; for the flaming coal combustion data points shown in figure 7B, the average calculated diameter is $0.38 \mu\text{m}$.

Detector F

Detector F is an ionization-type diffusion mode smoke detector. The response of the detector for smoldering and flaming coal combustion is shown in figures 3 and 4. As the figures indicate, the detector alarm results in an electrical contact without any earlier indication of smoke detection, as would be indicated by a detector with a continuous analog output signal. For the two smoldering coal combustion experiments, the alarm occurred at an average optical density of $0.12 \pm 0.003 \text{ m}^{-1}$. Alarm occurred at an average optical density of $0.077 \pm 0.029 \text{ m}^{-1}$ for the two flaming coal combustion experiments. This would indicate the detector is more responsive to flaming than smoldering combustion.

The measured results reported above can be used to quantify the concept of alarm based on optical obscuration for the commercially available detectors. From the perspective of establishing a reliable smoke detector alarm based on detector output voltage, the signal change must be some factor times the peak-to-peak noise of the detector. Table 2 shows the measured noise in the background signal in clear air for the detectors with an analog voltage output, detectors A to D. If the factor was 10, for example, then reliable signal values for detectors A, B, C, and D would be 0.5, 0.52, 1.04, and -0.84. These projected values can be compared with measured values for specific optical densities.

Table 3 lists the average signal and standard deviation for smoldering and flaming experiments for optical density values of 0.011, 0.022, 0.033, and 0.044 m^{-1} for detectors A to D. Based on the above consideration of a projected alarm value associated with a signal change of at least ten times the peak-to-peak noise values, a minimum reliable optical density can be determined for each detector alarm using the average background and noise values in table 2. In this example, based on the average values reported in table 3, detectors A, C, and D would be in alarm at an optical density of 0.011 m^{-1} ; detector B would be in alarm at an optical density of 0.033 m^{-1} . The choice of ten for the factor represents a reasonable expectation of a selected alarm value that is not affected by detector background noise.

Table 2.—Smoke detector background signal and noise for detectors A to D, V

Detector	Background	Noise
A	0.1	± 0.02
B	0.4	± 0.006
C	1.0	± 0.002
D	-0.9	± 0.003

Table 3.—Smoke detector response at optical densities of 0.011, 0.022, 0.033 and 0.044 m^{-1} for detectors A-D

Detector	0.011		0.022		0.033		0.044	
	Av	SD	Av	SD	Av	SD	Av	SD
A:								
Smoldering	1.02	0.25	2.34	0.38	2.73	0.03	2.75	0.02
Flaming	0.70	0.30	1.33	0.42	1.88	0.58	2.37	0.53
B:								
Smoldering	0.47	0.01	0.52	0.01	0.59	0.0	0.64	0.0
Flaming	0.45	0.0	0.50	0.0	0.53	0.0	0.56	0.0
C:								
Smoldering	2.52	0.23	4.27	0.48	NAp	NAp	NAp	NAp
Flaming	NAp	NAp	NAp	NAp	NAp	NAp	NAp	NAp
D:								
Smoldering	-0.83	0.0	-0.77	0.01	-0.72	0.01	-0.67	0.02
Flaming	-0.74	0.04	-0.61	0.04	-0.52	0.03	-0.46	0.02

Av Average.
 SD Standard deviation.
 NAp Not applicable.

The results in tables 2 and 3 can be used to make a comparison of the signal's change above background at an optical density of 0.022 m^{-1} for smoldering and flaming coal combustion. For detectors A and B, the ratio of the change in signal above background for smoldering to flaming coal combustion was 1.8 and 1.2. For detector D, the ratio in signal change of flaming to smoldering coal combustion was 2.2. For detector C, the maximum analog signal was achieved in the flaming combustion case prior to an optical density of 0.022 m^{-1} , and a numerical ratio cannot be assigned.

CO MEASUREMENT

For each of the experiments, the CO in the smoke chamber was continuously measured with two Ecolyzer CO sensors. Figure 8A shows the CO increase with respect to optical density for five smoldering coal combustion experiments. Figure 8B shows the CO increase with respect to optical density for five flaming coal combustion experiments. Four of the five experiments reported in figure 8A correspond to the four experiments reported in figure 3; similarly, four of the five experiments reported in figure 8B correspond to the four experiments reported in figure 4. The values in figure 8 are the result of mathematically smoothing the measured values. This was done because of the fluctuations in the optical density. The measured response of CO was nearly linear with respect to optical density for smoldering and flaming coal combustion.

The average CO concentration in the smoke chamber was evaluated at an optical density of 0.022 m^{-1} for 12 smoldering and 10 flaming coal combustion experiments. For the smoldering experiments, the sample average CO concentration is 4.9 ppm above ambient, with a standard deviation of 1.1 ppm, and for the flaming experiments, the sample average CO concentration is 4.6 ppm above ambient, with a standard deviation of 1.8 ppm. It can be stated that an optical density of 0.022 m^{-1} corresponds to an average CO concentration of 5 ppm above ambient for both smoldering and flaming combustion under these experimental conditions.

ODOR MEASUREMENT

The Sensidyne odor monitor was observed in both the smoldering and flaming coal combustion experiments to respond early relative to smoke and CO detection. Although the odor monitor responds to many gaseous compounds, the response sensitivity is greater for aromatic hydrocarbons. The instrument response is read as arbitrary units, with a range of

$\pm 2,000$ units. The analog signal corresponding to one unit is 0.1 mV. The instrument response is linear on a log-log scale with respect to a pure gas component. A product gas component associated with a sulfur-containing coal such as Pittsburgh Seam coal is H_2S . The odor monitor responds to H_2S concentrations as great as 10 ppm. The threshold human odor response to H_2S is 0.1 ppm. According to the manufacturer's response chart, an H_2S concentration of 1 ppm corresponds to a monitor reading of 210 arbitrary units. Since a manufacturer's value was available, a reading of 210 above background was selected as a criterion for comparison purposes for an odor monitor alarm and other detectors. A comparison of the response of the CO detector and odor monitor for eight smoldering experiments and seven flaming experiments showed their initial response to products of combustion was within 130 s of each other. A comparison was made of the odor monitor alarm time with the CO detector alarm time, which is the time for the CO concentration to reach 5 ppm above background. Figure 9 shows a comparison of the times for the eight smoldering and seven flaming coal combustion experiments. The data were not available for the other seven experiments. The line for perfect correlation is also shown in figure 9. Figure 9 shows that in seven of the eight smoldering coal combustion experiments, the identified odor monitor alarm occurs prior to the CO alarm time. The average background CO was less than 1 ppm. For the flaming coal combustion experiments, the sequence of alarm occurrence was almost equally divided between the odor monitor and the CO detector. This is consistent with previous research (3) in the USBM intermediate scale tunnel that showed for heating of larger-size coal particles, the odor monitor alarm occurred after the CO reached 5 ppm above background; for mine-size coal, the odor monitor alarm occurred prior to the CO level reaching 5 ppm above background. A comparison was also made of the odor monitor alarm response with the identified alarm time of sensor C for six smoldering coal combustion experiments and five flaming coal combustion experiments. The results are shown in figure 10. Also shown is the line for perfect correlation. The alarm time for the odor monitor and smoke detector C is equally divided about the line for perfect correlation for the smoldering coal combustion experiments. For the flaming coal combustion experiments, smoke detector C registers an alarm prior to the odor monitor in four of the five flaming coal combustion experiments. This is in substantial agreement with a comparison of odor monitor response and smoke detector response for 10 experiments in the USBM intermediate scale tunnel (3).

For the tests conducted, a comparison could be made of the odor alarm time with respect to the time for the optical density to reach 0.022 m^{-1} . It was found that for 12 smoldering and 7 flaming coal combustion experiments that the odor monitor

indicated an alarm in 11 of the smoldering and 3 of the flaming coal combustion experiments prior to an optical density of 0.022 m^{-1} .

CONCLUSIONS AND RECOMMENDATIONS

1. For each of the smoke detectors evaluated for which a continuous analog signal was the measurable output, the smoke detectors showed a nearly coincidental initial response with an increase in the optical obscuration.

2. An average CO concentration of 5 ppm above ambient was determined to correspond to an optical density of 0.022 m^{-1} for the smoldering and flaming coal combustion experiments. This is significant for establishing the equivalence of CO and smoke detection for mine-wide early warning fire detection systems.

3. For the smoldering coal combustion experiments, the identified odor monitor alarm showed an advantage with respect to CO detection (5 ppm alarm), but did not demonstrate an improvement with respect to CO detection for the flaming combustion experiments.

4. Detector A, an optical, diffusion-mode smoke detector based on light scattering, showed a significant difference between smoldering and flaming coal combustion when the detector's analog output signal was compared with respect to the optical density. Although the response was linear for both smoldering and flaming combustion, the rate of increase was greater for smoldering than for flaming coal combustion. At an optical density of 0.022 m^{-1} , the ratio of the change in the detector's analog output above background of smoldering to flaming coal combustion was 1.8.

5. At an optical density of 0.022 m^{-1} , the ratio of the change in detector B's analog output above background of smoldering to flaming coal combustion was 1.2. The experiments conducted showed that detector B would not indicate an alarm for an optical density less than 0.022 m^{-1} based on a criterion for detector alarm that defined the alarm point as average signal plus ten times the peak-to-peak noise.

6. For smoke detector C, which had an identifiable alarm, the smoke detector alarm and identified odor monitor alarm were at nearly equivalent times for the smoldering coal combustion experiments. For flaming coal combustion, the smoke detector alarm occurred prior to the odor monitor alarm. Smoke detector C alarmed at a lower optical density for flaming than for smoldering coal combustion. At an optical density of 0.022 m^{-1} , the output signal for detector C for flaming coal combustion had reached the instrument's maximum value, whereas the signal was less than maximum for smoldering coal combustion.

7. Detector D, an ionization, diffusion-mode smoke detector, showed a linear response of the analog output signal with respect to the optical density for smoldering coal combustion, and nonlinear for flaming coal combustion. Based on an evaluation with respect to optical density, detector D showed a greater responsiveness to flaming than to smoldering coal combustion. At an optical density of 0.022 m^{-1} , the ratio of the change in the detector's analog output above background of flaming to smoldering coal combustion was 2.2.

8. The analog output signal from the MIC expressed as a measurable quantity was compared with a quantity derived from the output voltages of the pump-mode, ionization-type detector, detector E. The derived quantity is the product of the smoke particulate number concentration and the number mean smoke particulate diameter. For both smoldering and flaming combustion the dependence was linear. Further analysis showed the smoke particulate diameter is larger for smoldering than for flaming combustion.

9. Ionization-type smoke detectors C and D responded with greater signal intensity to flaming than to smoldering coal combustion. The optical-type smoke detectors, detector A and detector B, responded with greater signal intensity to smoldering than to flaming coal combustion. The comparison was based on smoke optical density of 0.022 m^{-1} . The alarm for detector F, an ionization-type smoke detector, occurred at a lower optical density for flaming than for smoldering coal combustion.

10. A comparison of the measured signal of the commercially available analog-output-type smoke detectors, A to D, showed that for detectors A, C, and D, an alarm could be established at an optical density of 0.011 m^{-1} without expecting a false alarm due to detector electrical noise, whereas for detector B, an alarm could be identified at a smoke optical density of 0.033 m^{-1} .

Important implications for evaluation of smoke detector approval for in-mine use as part of a mine fire detection strategy is, first, determining the optical density at which a smoke detector is required to respond and, second, determination of the reliability of the smoke detector. The optical density at which the detector should respond is reasonably expected to correspond to a CO concentration no greater than the current reliability of CO sensors.

It is recommended for the evaluation of a smoke detector with a measurable analog output, the detector alarm should be selected such that the alarm signal is the background signal in clear air plus some factor times the peak-to-peak noise in clear air. Smoke detectors with either continuous analog output signals or a manufacturer-set alarm should be evaluated for reliability with repetitive testing in a smoke chamber under environmental conditions of dust, humidity, and temperature expected in mining operations. The minimum optical density

at which the smoke detector alarms should be determined for smoldering and flaming combustion of expected fuel sources in a mine. The CO concentration at the smoke detector alarm should be evaluated for smoldering and flaming fuel combustion. This provides a relative comparison of CO and smoke detector response to the combustion products for a particular smoke detector. Such a comparison assists in planning the most efficient mine fire detection system.

REFERENCES

1. Morrow, G. S., and C. D. Litton. In-Mine Evaluation of Smoke Detectors. USBM IC 9311, 1992, 13 pp.
2. Edwards, J. C., and G. S. Morrow. Development of Coal Combustion Sensitivity Tests for Smoke Detectors. USBM RI 9551, 1995, 12 pp.
3. Edwards, J. C. Detection of Smoldering Combustion of Coal with an Odor Meter. Proceedings of 12th WVU International Mining Electrotechnology Conference, Dept. of Electrical and Computer Engineering, College of Engineering, West Virginia Univ., Morgantown, WV, July 27-29, 1994, pp. 150-154.
4. Jin, T. Studies of Emotional Instability in Smoke from Fires. *J. of Fire and Flammability*, v. 12, April 1981, pp. 131-142.
5. Rasbash, J. D. Sensitivity Criteria for Detectors Used To Protect Life. *Fire International*, v. 5, No. 49, Sept. 1975, pp. 30-44.
6. Litton, C. D., C. P. Lazzara, and F. J. Perzak. Fire Detection for Conveyor Belt Entries. USBM RI 9380, 1991, 23 pp.
7. Hottel, H. C., and A. F. Sarofim. *Radiative Transfer*. McGraw Hill Book Co., NY, 1967, pp. 201-203.
8. Edwards, J. C., M. R. Egan, and J. Corry. CO and Smoke Signatures for Smoldering Coal Combustion. 1993 Annual Conference on Fire Research: Book of Abstracts, NIST, U.S. Dept. of Commerce, NIST IR 5280, Oct. 1993, pp. 125-126.
9. Litton, C. D., L. Graybeal, and M. Hertzberg. Submicron Particle Detector and Size Analyzer. *Rev. Sci. Instrum.* v. 50, No. 7, July 1979, pp. 817-823.

Figure 1

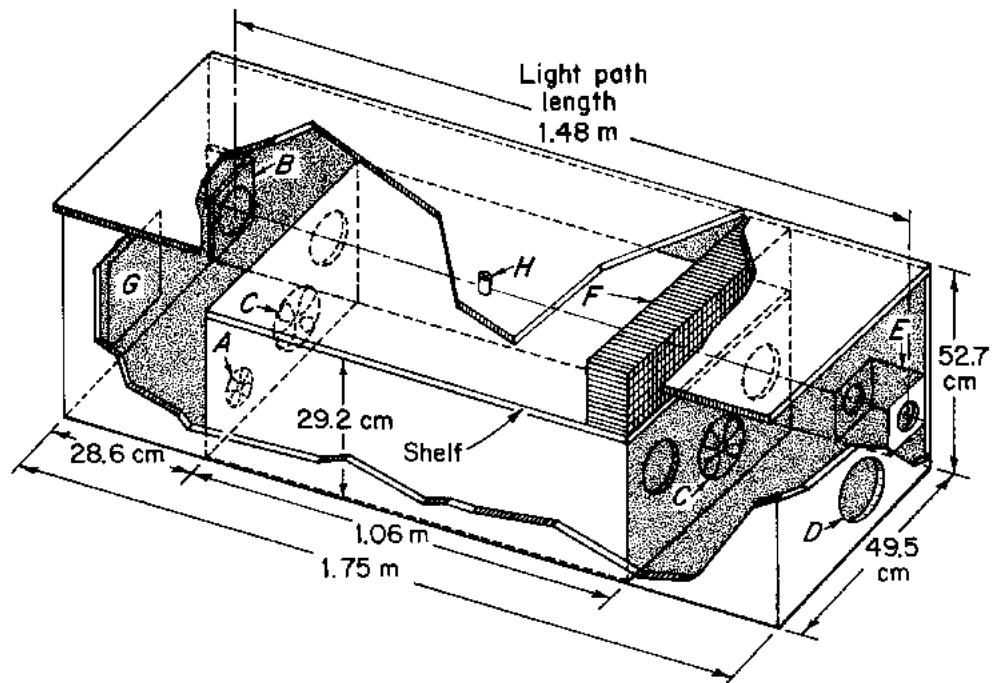

Key

- | | | | |
|---|--------------------------|---|---------------------------------|
| A | 12-V dc circulating fan | E | Photocell |
| B | 6-V automotive lamp | F | Honeycomb (air straightener) |
| C | 120-V ac circulating fan | G | Access door from sample chamber |
| D | Exhaust port with damper | H | Sample port |

Schematic of the smoke chamber.

Figure 2

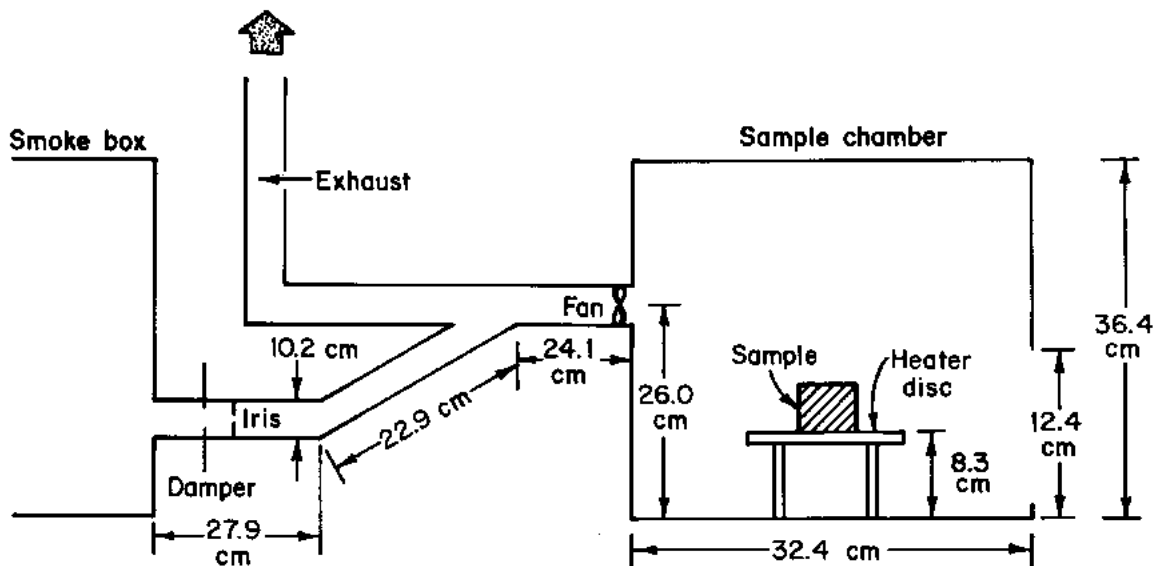

Schematic of the sample chamber.

Figure 3

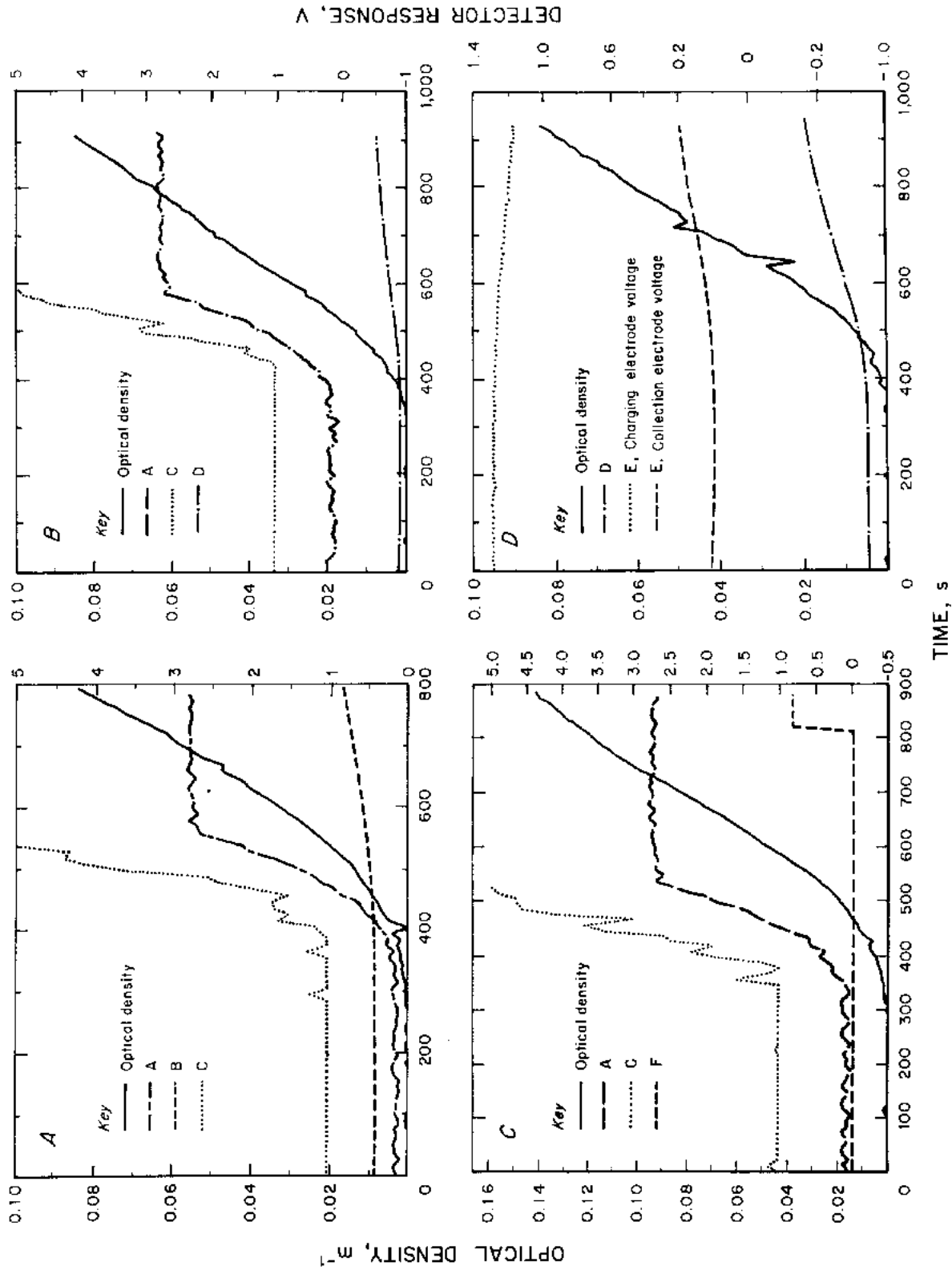

Optical density and response of detectors for smoldering coal combustion.

Figure 4

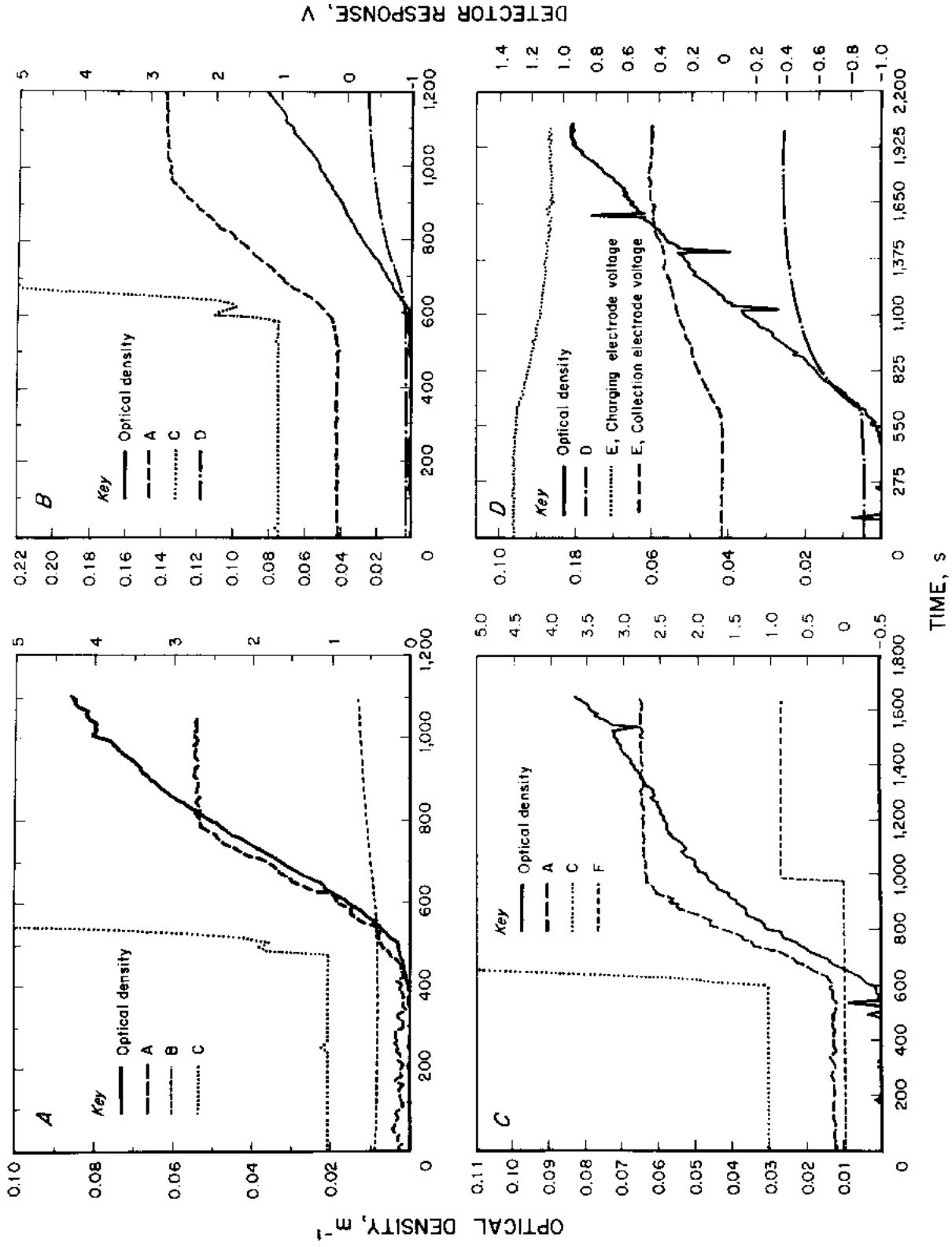

Optical density and response of detectors for flaming coal combustion.

Figure 5

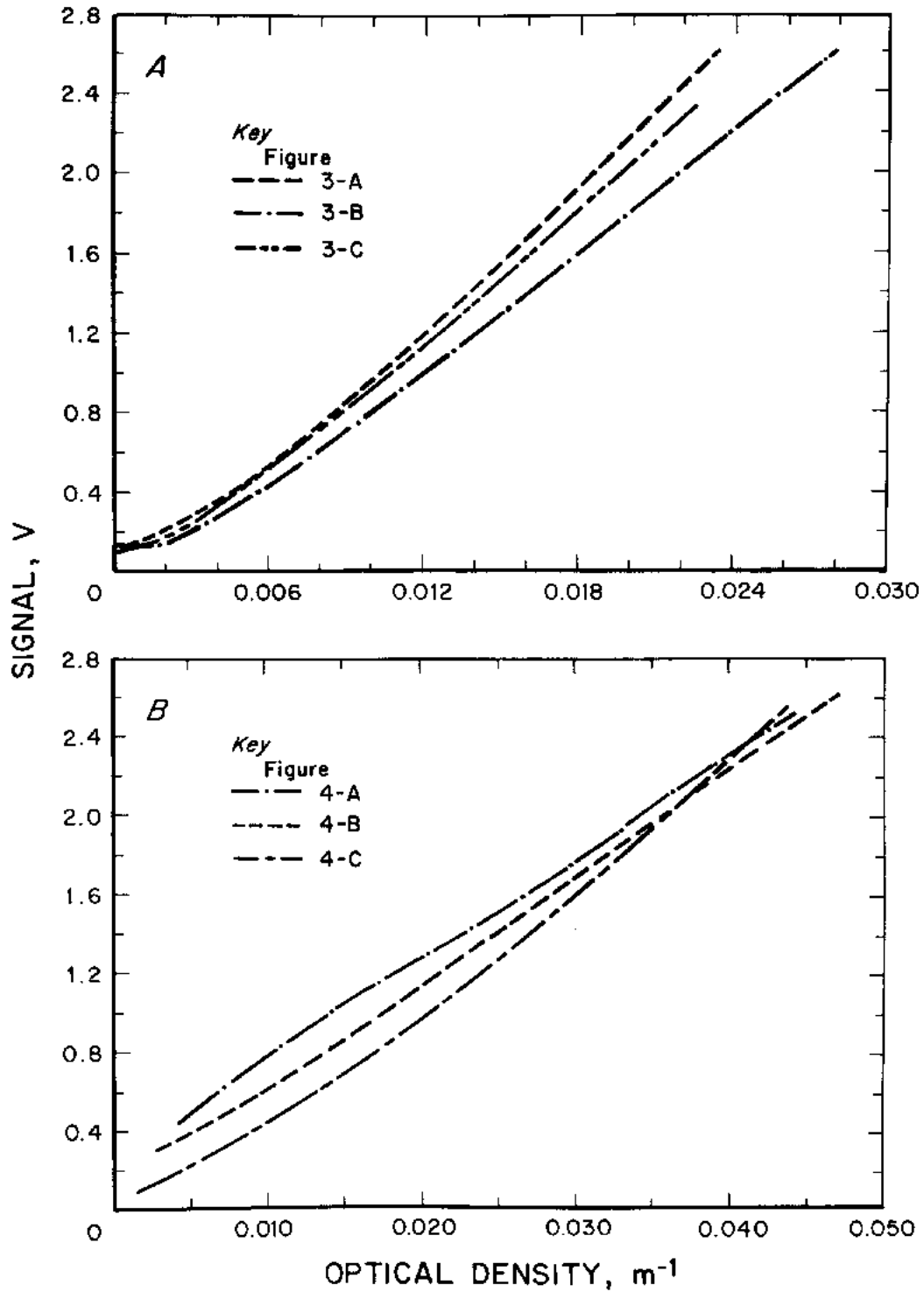

Response of detector A with respect to optical density for smoldering (A) and flaming (B) coal combustion.

Figure 6

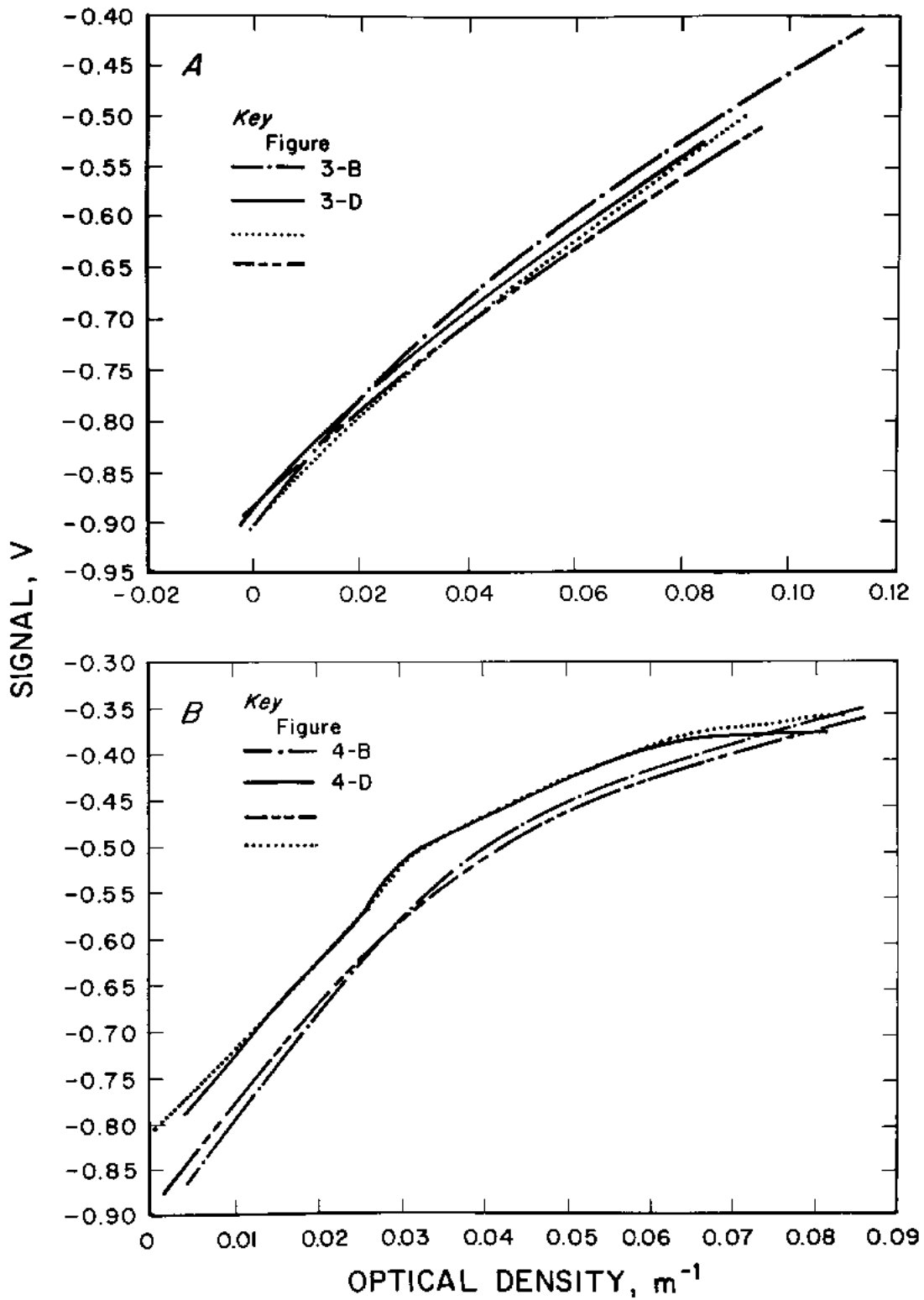

Response of detector D with respect to optical density for smoldering (A) and flaming (B) coal combustion.

Figure 7

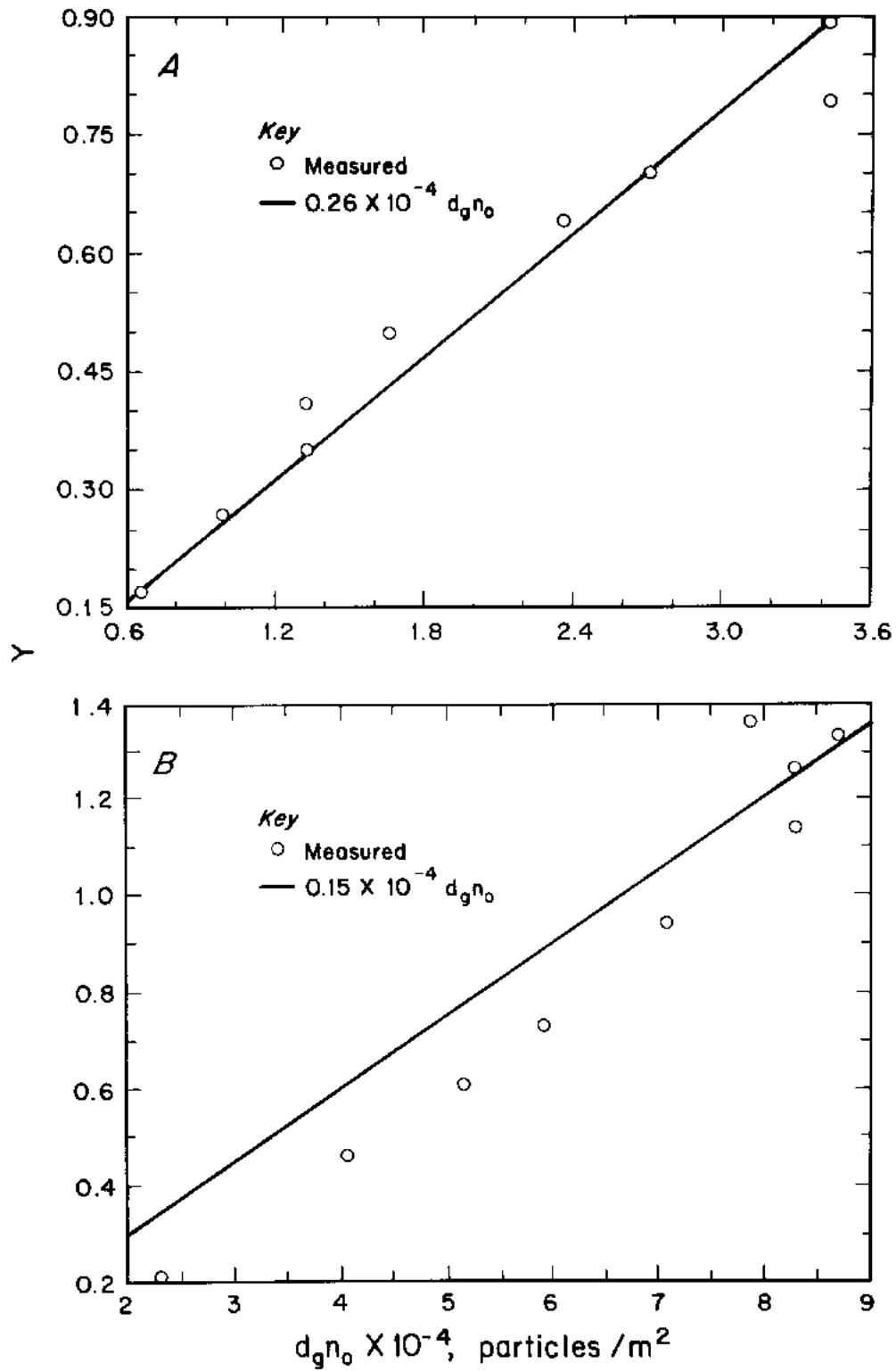

Response of MIC with respect to $d_g n_o$ determined from measurements with detector E for smoldering (A) and flaming (B) coal combustion.

Figure 8

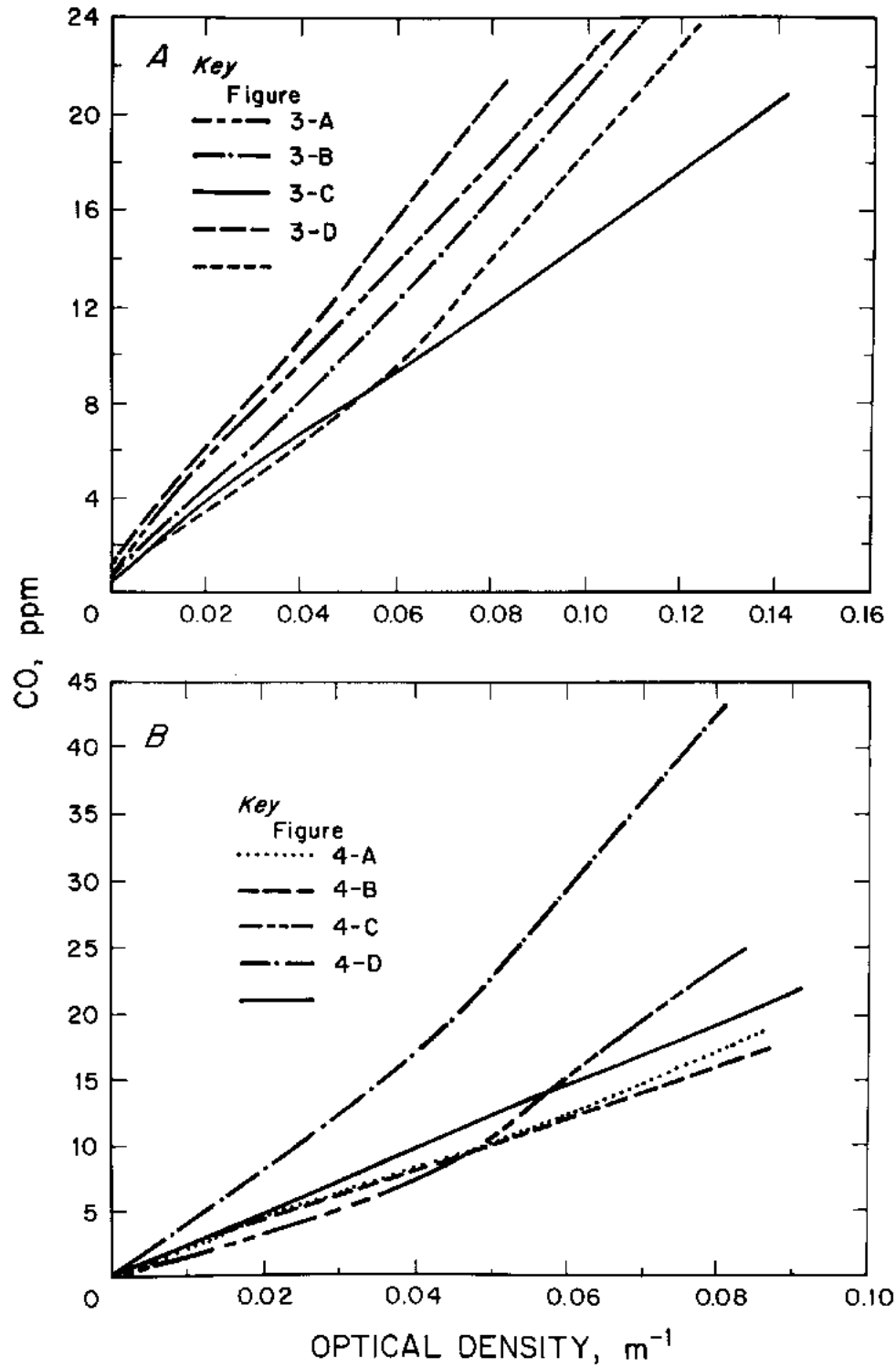

Measured CO concentration dependence on optical density for smoldering (A) and flaming (B) coal combustion.

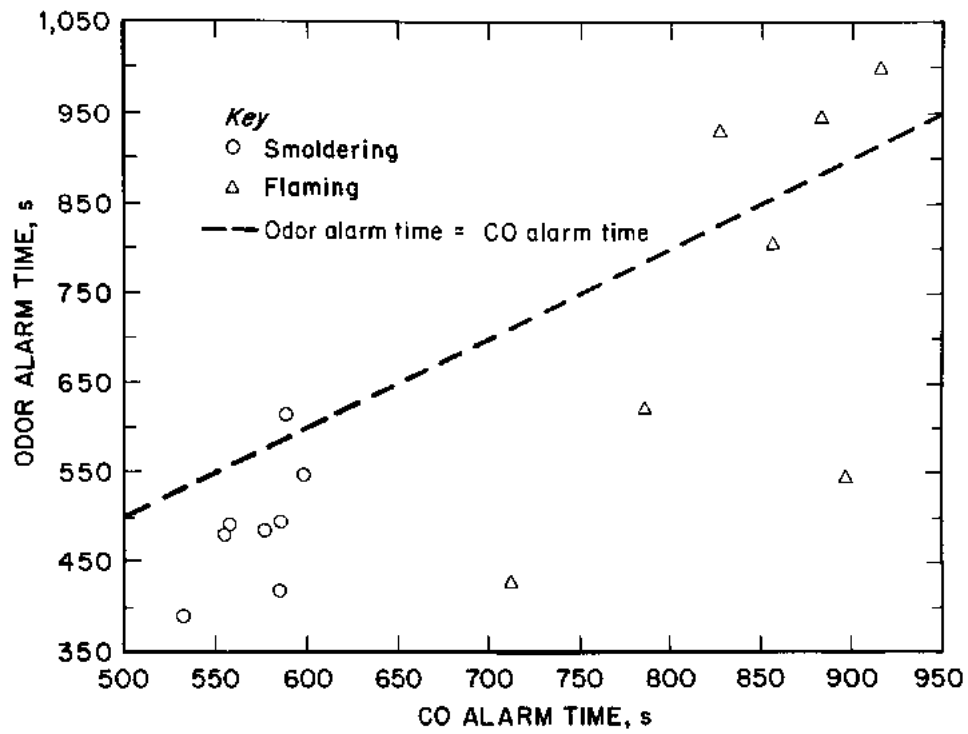
Figure 9

Correlation of odor monitor alarm time with time for CO concentration to reach 5 ppm above background for smoldering and flaming coal combustion.

Figure 10

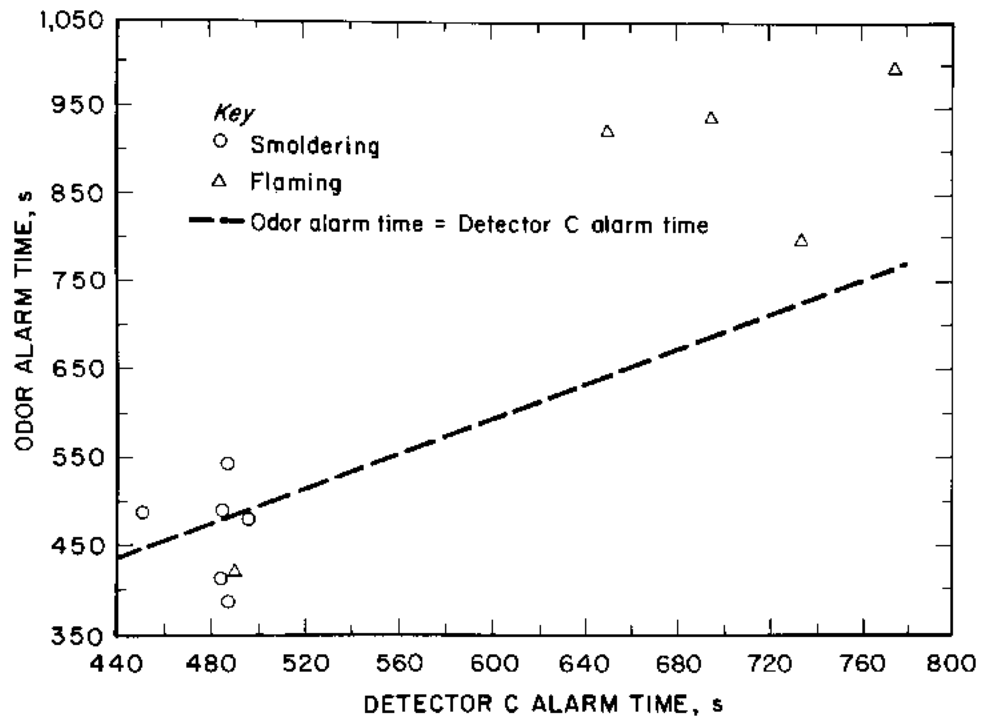

Correlation of odor monitor alarm time with smoke detector C alarm for smoldering and flaming coal combustion.