

Using Ground Penetrating Radar for Roof Hazard Detection in Underground Mines

By Gregory M. Molinda, William D. Monaghan, Gary L. Mowrey
and George F. Persetic



UNITED STATES DEPARTMENT OF ENERGY

PITTSBURGH RESEARCH CENTER



Report of Investigations 9625

Using Ground Penetrating Radar for Roof Hazard Detection in Underground Mines

By Gregory M. Molinda, William D. Monaghan, Gary L. Mowrey
and George F. Persetic

This work was performed by the U.S. Bureau of Mines prior to transferring to the Department of Energy on April 4, 1996

UNITED STATES DEPARTMENT OF ENERGY

PITTSBURGH RESEARCH CENTER

CONTENTS

| | <i>Page</i> |
|---|-------------|
| Abstract | 1 |
| Introduction | 2 |
| Ground penetrating radar (GPR) theory | 2 |
| Field test of GPR | 3 |
| Description of the instrumentation | 3 |
| Field sites | 4 |
| Collier Stone Quarry | 4 |
| Lake Lynn Limestone Mine | 4 |
| RoxCoal Coal Mine | 6 |
| Safety Research Coal Mine | 7 |
| Applicability of GPR to coal mine roof hazard detection | 13 |
| Conclusions | 14 |
| References | 14 |

ILLUSTRATIONS

| | |
|--|----|
| 1. GPR ray paths penetrating the ground and producing a wiggle trace on the control panel | 2 |
| 2. SIR-2 GPR system | 3 |
| 3. Collecting GPR data from a 900-MHz antenna through a stack of sandstone slabs | 4 |
| 4. GPR record of Collier Stone Quarry sandstone stack with actual slab locations drawn as overlays | 5 |
| 5. GPR survey lines and stratascope holes at Lake Lynn limestone mine | 6 |
| 6. Stratascope logs of bed separations in the roof at Lake Lynn limestone mine | 6 |
| 7. Stratascope image of large open crack 1.7 m (5.5 ft) into the roof at Lake Lynn limestone mine at hole No. 3 | 7 |
| 8. GPR record at hole No. 2 at Lake Lynn showing crack reflections | 8 |
| 9. GPR record at hole No. 3 at Lake Lynn | 8 |
| 10. GPR survey lines and roof damage at RoxCoal Coal Mine | 8 |
| 11. GPR record of immediate roof at location 4 in RoxCoal Coal Mine with lithology and roof cracks from stratascope hole overprinted | 9 |
| 12. GPR survey line and corehole in immediate roof at the Safety Research Coal Mine (SRCM) | 9 |
| 13. Lithology in the immediate roof at the SRCM | 9 |
| 14. 900-MHz GPR record at the SRCM with overlay of lithology | 10 |
| 15. 500-MHz GPR record at the SRCM with overlay of lithology | 11 |
| 16. 300-MHz GPR record at the SRCM with overlay of lithology | 12 |

UNIT OF MEASURE ABBREVIATIONS USED IN THIS REPORT

| | | | |
|----|------------|-----|------------|
| cm | centimeter | MHz | megahertz |
| ft | foot | mm | millimeter |
| in | inch | ns | nanosecond |
| m | meter | ° | degree |

Reference to specific products does not imply endorsement by the U.S. Bureau of Mines

USING GROUND PENETRATING RADAR FOR ROOF HAZARD DETECTION IN UNDERGROUND MINES

By Gregory M. Molinda,¹ William D. Monaghan,² Gary L. Mowrey² and George F. Persetic³

ABSTRACT

Ground penetrating radar (GPR) has been investigated by the U.S. Bureau of Mines Pittsburgh Research Center for its potential to determine roof hazards in underground mines. GPR surveys were conducted at four field sites with accompanying ground truth to determine the value of GPR for roof hazard detection. The resolution of the current system allows detection of gross roof fractures (>6.4 mm (>0.25 in) zone) or rider beds in coal measure roof. Data quality is not yet sufficient to detect small bed separations or subtle lithologic changes in the roof. Differences in data quality are discussed, as well as suggestions for collecting improved data.

¹Geologist.

²Electrical engineer.

³Physical science technician.

Pittsburgh Research Center, U.S. Bureau of Mines, Pittsburgh PA.

INTRODUCTION

Groundfalls accounted for almost one-half of fatalities in U.S. underground coal mines in 1987-94 (1, p. 2; 2).⁴ Additionally, the average cost per underground accident resulting in a permanent disability approached \$500,000 in 1990 (3). In underground limestone mines, 11 miners were killed and 9 injured since 1985 in falls of ground (4, p. 2). The risk of serious injury to a coal miner is greatest at the working face.

When humans are relocated away from the working face, the traditional methods of mine roof stability monitoring are also removed. There are many indicators that a miner or bolter operator would use to determine whether a roof is unsound. Initial flaking or spalling of immediate roof may damage the machine or indicate imminent larger failure. The sound of "working" roof is an important indicator. Roof sag or bed separation over time may indicate instability. "Cutter" roof, a failure of weak rock due to horizontal stress from weak rock, is

often a precursor to failure. Lithologic parameters, e.g., a thickening claystone, may cause the roof bolts to anchor in weak strata. A roof bolt operator can usually detect these lithologic changes by drill cuttings or vibration changes. Staying in the coal seam horizon and leaving a specified amount of roof coal may also be critical to roof control. An operator can often tell the correct horizon by some marker within the coal seam (i.e., parting).

Technology is now available that may be able to enhance the ability of mines operators to detect roof hazards. One promising technology is *ground penetrating radar* (GPR). This report presents the results of field testing of GPR by the U.S. Bureau of Mines (USBM) Pittsburgh Research Center for its application in providing early warning to underground mine workers of potential roof hazards, thereby improving mine safety.

GROUND PENETRATING RADAR (GPR) THEORY

GPR is a geophysical technique based on radar technology and is primarily used to detect shallow subsurface objects, such as pipes, barrels, saturated zones, water- or air-filled mine openings, caves, or fault planes (5). New USBM applications for GPR have been to monitor highwall thickness and the extent of a burning waste bank (6-8).

An antenna is moved across the surface of interest, and an electromagnetic pulse is transmitted into the ground at set intervals (e.g., 30 times per second). The pulse travels through the subsurface until it encounters an object of dissimilar electrical properties (e.g., dielectric constant) compared with the host material. Provided the pulse strikes an object, part of its energy is reflected back to the surface while the remaining energy continues to propagate through the subsurface materials. The reflected energy is detected by a receiving antenna at the surface. For each transmitted pulse, the resultant reflected signal is detected, digitized, and displayed and/or plotted as a trace.

The lineup of the disturbance, variations of adjacent traces while the antenna is being moved over the surface at a uniform speed, creates an "image of the subsurface" as shown in figure 1. The depth to the reflecting surface is determined by dividing the two-way travel time to the object by two times the velocity of the electromagnetic wave through the ground. Different earth materials have different electromagnetic wave propagation velocities, which are determined from the dielectric constant of each type of material. It is also possible to estimate the velocity of a material by using an appropriate dielectric constant for that material if known from previous experience or available from a dielectric table for geological materials.

The strength of the reflection is influenced by the differences in dielectric constant at two material boundaries. For example, the best-quality data are obtained by the reflections of surfaces or objects that have large material contrasts compared with the surrounding material and when the dielectric constant of the two materials is largely different (e.g., water-filled fractures, buried barrels, water table, concrete foundations, or open mine voids).

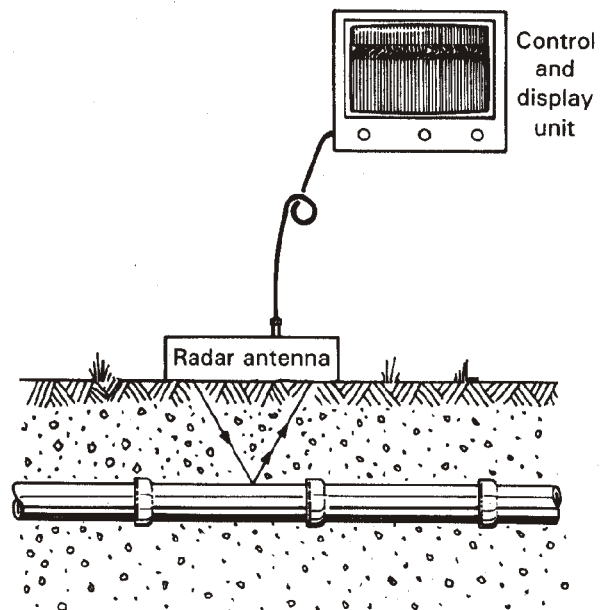

Figure 1.—GPR ray paths penetrating the ground and producing a wiggly trace on the control panel.

⁴Italic numbers in parentheses refer to items in the list of references at the end of this report.

Orientation of the boundaries with respect to the plane of the antenna also affects the reflected signal strength; boundaries that are perpendicular to the pulse direction produce the strongest reflections.

Several equipment parameters also influence data quality. The frequency of the transmitted wave influences both the depth of penetration and resolution of the pulse energy, which in turn influences the reflected record. For example, a

"higher-frequency" antenna (e.g., 900 MHz) has three times the resolution, but one-third the depth of penetration, compared with a "lower-frequency" antenna (300 MHz). Other factors that influence data quality include amount of contact with (or air-gap distance from) the surface, electrical interference from cultural noise sources (e.g., buried pipes, cables, trenching, power lines, radio/TV transmitters, etc.), and maintaining a uniform speed when moving the antenna along a straight line.

FIELD TEST OF GPR

The purpose of the field studies was to determine whether GPR could identify potentially hazardous roof situations. The sensing goals for GPR are to—

1. Identify bed separations 6.4 mm (0.25 in) and larger. Bedding separation is a precursor to bed "unraveling," which may result in a roof fall.
2. Determine if the common coal measure roof interfaces (shale/coal, sandstone/shale, sandy shale/claystone, etc.) would be distinguishable with GPR. A continuous roof profile would be invaluable in assessing roof hazards.
3. Identify large structures in the roof that may indicate hazards (e.g., sandstone channels, faults, shears, fault gouge zones, open fracture zones).
4. Concentrate on identifying roof hazards within the bolted interval (≤ 2.4 m (≤ 8 ft)), but also up to 6.1 m (20 ft) into the roof.

To set up the most practical test of GPR data quality, it was decided to—

1. Use earth materials.
2. Utilize a physical model to eliminate complex geology.
3. Conduct underground experiments under similar conditions in which the instrument would be working.

DESCRIPTION OF THE INSTRUMENTATION

Following is a brief description of the radar system used in the study.

The SIR-2 is a lightweight, portable, general-purpose radar system (figure 2) (5). An electromagnetic transmit pulse generated by the system is injected into the subsurface via an antenna that is moved along the surface at a uniform speed and direction. The transmitted energy of the pulse is radiated in an elliptical conical pattern roughly 90° front to back and 60° side to side. The transmit pulse encounters different materials in the subsurface, each of which has different dielectrical properties. Wherever there is a change in the subsurface material and dielectric constant, a portion of the pulse energy is reflected back to the surface and is detected by the receiving antenna. This reflected pulse provides information regarding two-way travel time and attenuation characteristics (signal strength) associated

with the subsurface materials. The received return pulse is then processed by the control unit in the radar system, and the data are displayed on a monitor and/or stored on an internal hard disk. The output display can be (1) a single wiggle trace (analogous to an oscilloscope trace), (2) a waterfall plot of these wiggle traces, or (3) a multicolored line scan in which reflected signal amplitudes are represented by various colors according to a user-selected color look-up table. The data can also be printed via an external printer.

The two-way travel time is determined by measuring the time interval between the start of the transmit pulse and the start of the received reflected signal. The amplitude of the reflected signal is influenced by the size and geometry of the target, the signal attenuation characteristics of the geological materials, and the total distance that the pulse has to travel.

How well GPR works depends on two electrical properties of the geological materials under investigation: dielectric constant (relative dielectric permittivity) and electrical conductivity. The dielectric constant affects the velocity of propagation of the radar pulse. The values of the dielectric constant range from 1 for air (fastest propagation) to 81 for water (slowest propagation). The greater the difference in dielectric constant between two materials, the stronger the reflected pulse energy becomes. The

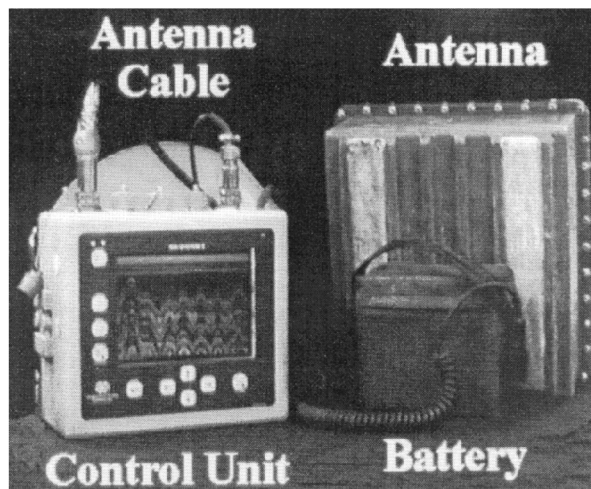

Figure 2.—SIR-2 GPR system.

electrical conductivity controls the depth of pulse penetration. The lower the conductivity of the material, the deeper the radar pulse can penetrate. The conductivity is controlled by the water, mineral, and clay content in the subsurface. The depth of penetration of the radar pulse also depends on the antenna frequency. Higher frequency antennas (e.g., 900 MHz) provide high resolution, but shallow depths of penetration; conversely, lower frequency antennas (e.g., 300 MHz) have low resolution, but can detect significantly deeper targets.

FIELD SITES

Four field sites were chosen to test GPR. A stack of sandstone slabs from a Pennsylvania quarry was chosen as a physical model to represent air gaps between roof units. A limestone mine was chosen because of the relative simplicity of the roof. At this site, only limestone was present in the immediate roof. The remaining field sites were two Pennsylvania coal mines in two different seams representing common roof conditions.

Collier Stone Quarry

The Collier Stone Quarry in Allegheny County, PA, is mining the Morgantown sandstone primarily for building facing and decorative pieces. A stack of seven cut slabs (259 by 160 by 6.4 cm (102 by 63 by 2.5 in)), with slabs separated by 6.4-cm (2.5-in) blocks, was used to model a sequence of coal mine roof members (figure 3). The separation between the slabs was intended to simulate bed separation and air gaps. Although separation in an actual roof sequence rarely exceeds 1.27 cm (0.5 in) without failure, the larger gaps were intended to accommodate a metal target inserted between the slabs. Figure 3 shows the stack of sandstone slabs with the 900-MHz antenna attached to the control unit recording data from the top of the sandstone stack. Radar data were recorded as the target was inserted between the slabs beginning at the bottom of the stack



Figure 3.—Collecting GPR data from a 900-MHz antenna through a stack of sandstone slabs.

and ending at the top. Figure 4 is the resulting radar record. Overlain on the record is the "known" sandstone stack configuration. In this instance, the antenna remains stationary on the top of the stack. The resulting radar record is a time record on the horizontal axis and not a measure of horizontal change in material properties as in a traverse.

The overlay was constructed by scaling the total height of the stack (84 cm (33 in)) to match the total height range of the GPR survey (12 ns). The top of the stack is visually picked on the GPR record by the first reflection. Targets are identified by disturbances in the record, which represent reflections of the pulse. Whereas the general target locations are easily identified as significant disruptions in reflecting boundaries on the radar record, it is difficult to delineate the individual slab (6.4 cm (2.5 in) thick) and air gap (5.7 cm (2.25 in) thick) boundaries. The record shows numerous "false" slab boundaries and gives the appearance of numerous stacked slabs. This is probably due, again, to interference of reflected energy from the top and bottom of slabs. This problem of complicated geometry will be seen again in the coal roof test sites. Part of the problem lies in the interpretation criteria. When using the dynamic record, the eye is drawn to areas of high- and low-signal amplitude. Postprocessing can eliminate many extraneous interfaces. The interfaces between air and sandstone slab are not clearly delineated. Without the benefit of the known stack boundaries, it would be difficult to accurately recreate the stack. It can also be seen that all radar data are garbled below the target. This may be explained by transmission interference and reverberations of energy that have passed through the target. The remaining energy is reflecting back to the surface, but is also reflecting back off of the target bottom. As mentioned before, it is the contrast in dielectric constant between components that makes a good reflecting surface. Conducting materials present an effective barrier to radar transmission (i.e., water-bearing zones, pipes). For this reason, the metal foil of the target was easily seen. The metal target also formed an effective barrier to radar transmission to reflecting surfaces below it. That is why the reflecting surfaces below the target are obscured. Although the contrast between sandstone (5 ns/0.3 m (1 ft)) and air (2 ns/0.3 m (1 ft)) is great, the complex reflecting patterns obscure the reflecting surface. The sandstone stack is a complicated series of reflecting surfaces that is not easily delineated by GPR.

Lake Lynn Limestone Mine

To avoid the complex interface problems experienced at the stone stack at the Collier Stone Quarry, a test site was selected in the roof of the USBM's Lake Lynn underground limestone mine near Fairchance, Fayette County, PA. The mine is located geologically in the Greenbrier limestone formation and consists of mainly limestone with interbedded shales. The mine roof is one single member, a pure limestone up to the limit of the radar penetration of 6.1 m (20 ft). Figure 5 shows the location of two GPR survey lines run across the roof. Four roof holes, which

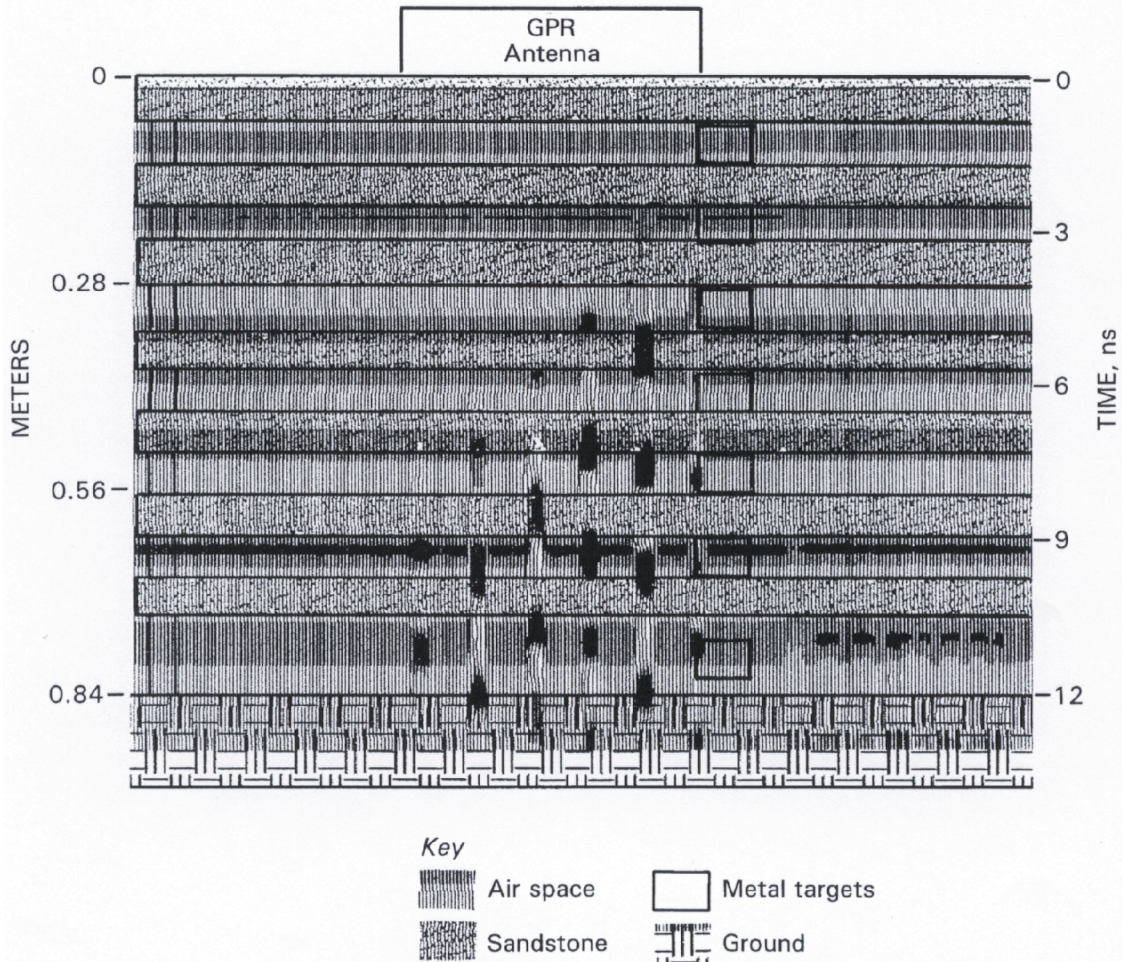

Figure 4.—Radar record of Collier Stone Quarry sandstone stack with actual slab locations drawn as overlays.

were used for instruments that measure strata movement, are also shown. Three of these holes were logged with a stratascope to verify any roof features such as shears, joints, or bed separations.

Figure 6 shows the roof features in the logs of stratascope holes Nos. 2-4. There was no access to hole No. 1 because of ground deformation instrumentation. A prominent fracture shows up in all three holes at 1.5-1.7 m (5.0-5.5 ft). This fracture is a large open break in hole No. 3, with broken rock and water leaking out. Figure 7 is a stratascope photograph of the feature. The structure is a bed separation with a joint abutting and stopping. Small rock fragments are also present. Other smaller fractures occur from the roof up to 1.7 m (5.5 ft), as detected by stratascope. There are no fractures detected above 1.7 m (5.5 ft). The large fracture at 1.7 m (5.5 ft) depth appears to be an extensional break due to roof sag, and the fracture appears on the radar record at hole No. 2 at approximately 1.5-2.4 m (5-8 ft)

(figure 8). The data were taken with a 500-MHz antenna with a range of 3 m (10 ft) into the roof. Figure 9 is the GPR record for the survey at hole No. 3. The fracture at 1.7 m (5.5 ft) appears as a zone covering approximately 15-30 ns (0.6-1.5 m (2-5 ft)). No other features appear clearly on the record.

Because the roof consists only of limestone, there is none of the bedding interference as seen with the sandstone air stack at the Collier Stone Quarry. The fracture appears to have made the reflection on the record, but it appears as a multiple reflection and not the clean interface seen in figure 7. This is probably due to the fragmented nature of the bed separation and joint intersection. Better resolution of this large feature is necessary, but this "recognition" is useful. From a data-quality standpoint, the contrast in material properties from a fracture in a single media is a good situation for radar reflection interpretation. A possible remediation for this 1.5-m (5-ft) thick slab would be

roof bolting, but the radar record indicates a slab anywhere from 0.6-2.4 m (2-8 ft) thick. Roof bolts would have to be at least 2.4 m (8 ft) long to consider the worst case. By contrast, an 2.4-m (8-ft) bolt could be excessive if the slab was 1.2 m (4 ft) thick.

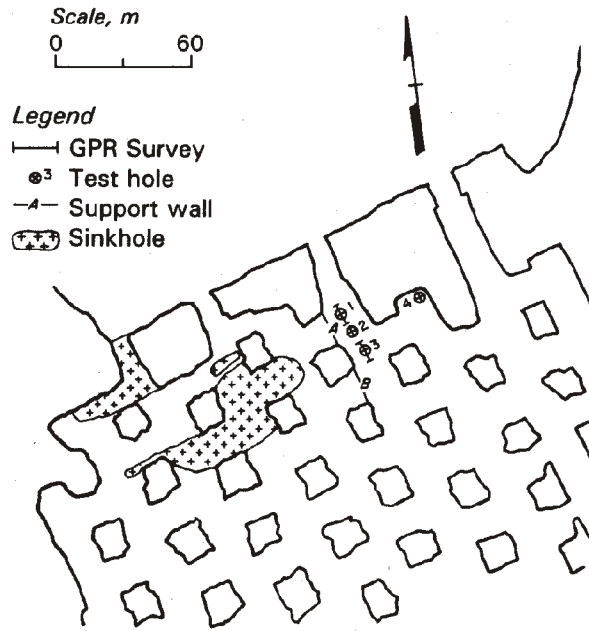

Figure 5.—GPR survey lines and stratascope holes at Lake Lynn limestone mine.

RoxCoal Coal Mine

Because the GPR system is intended to be used to sense potential coal mine roof hazards, a survey was conducted on an actual coal mine roof. A site was chosen in a section that was being driven in RoxCoal Coal Mine, Somerset County, PA. The section was planned as a future pillar section, and instruments were being placed in the roof to monitor roof bolt performance. The section was chosen because it was the area with the most roof damage. It was hoped that this damage would show up on the GPR record. Figure 10 shows the damage to the roof, mostly in the form of cutter roof, and the location of the GPR survey lines and the stratascope hole used for verification. A total of 12 GPR traverse lines were run: 6 used the 500-MHz antenna; 7 used the 300-MHz antenna.

The best data were obtained from location 4 using the 300-MHz antenna. Figure 11 shows a thick reflecting layer from 0.7-1.4 m (2.3-4.5 ft) up into the roof. Another prominent reflecting layer occurs from 3.2-3.5 m (10.5-11.5 ft). Verification of the roof features was obtained from a stratascope log of a nearby test hole, which was overlain on the radar data. There are a number of cracks logged, as noted up to 3.7 m (12 ft) in the test hole. From 0.8-1.1 m (2.5-3.5 ft), there are several large open cracks in the bolted roof. One crack has water leaking from it. It appears that the broad radar band is a reflection surface for this fracture zone. Again, these bands are broad and "smeared" out and represent only the same "zone" as the fractures. Other fractures at approximately 1.8, 2.1, and 2.4 m (6, 7, and 8 ft) are not represented as reflection surfaces. The band on the radar record at 3.2-3.5 m (10.5-11.5 ft) is the reflection surface of the rider seam above the main seam. There is good correlation

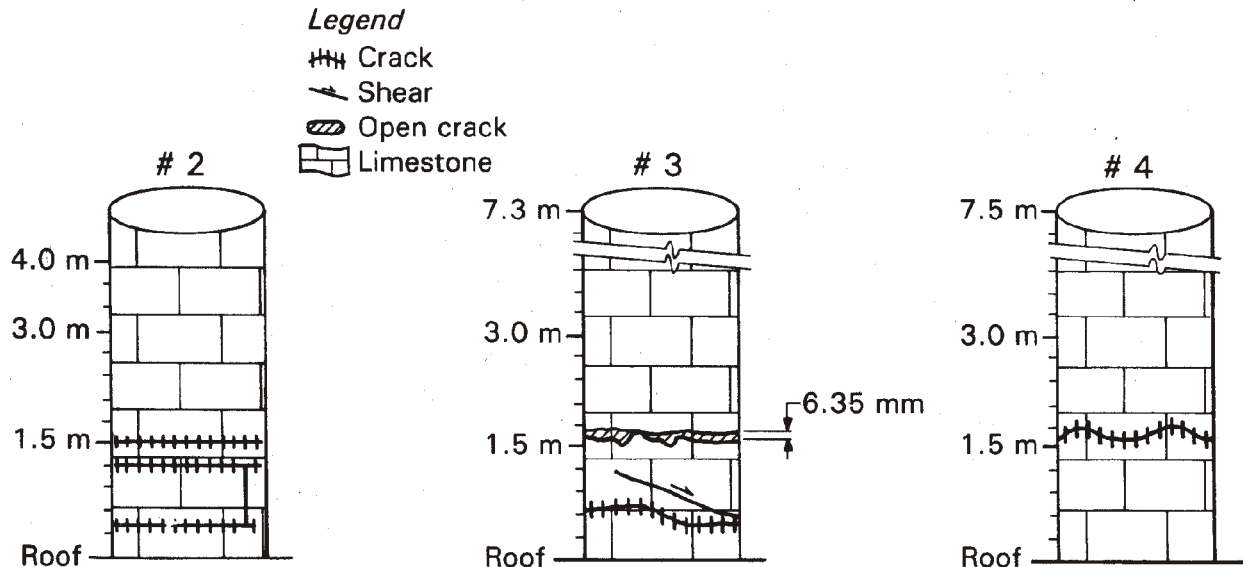

Figure 6.—Stratascope logs of bed separations in the roof at Lake Lynn limestone mine.

between the radar record and stratascope log. The location of the rider seam is important to roof control at this mine. The roof bolters track the rider position with blind test holes on regular intervals to avoid anchoring roof bolts into the rider seam.

Again, the larger open fractures are more prominent reflecting surfaces. However, it is clear from the radar record that the quality of the data is not good enough to be able to distinguish individual lithologies other than these noted.

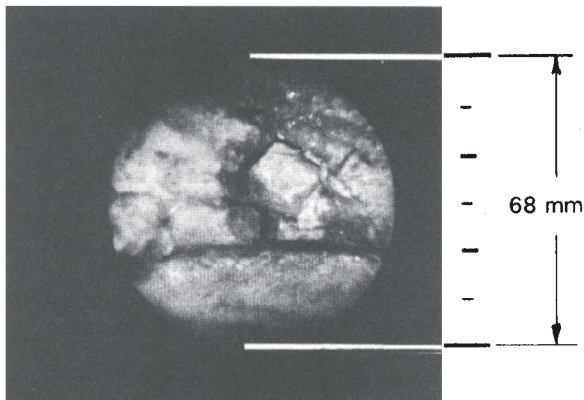

Figure 7.—Stratascope image of large open crack 1.7 m (5.5 ft) into the roof at Lake Lynn limestone mine at hole No. 3.

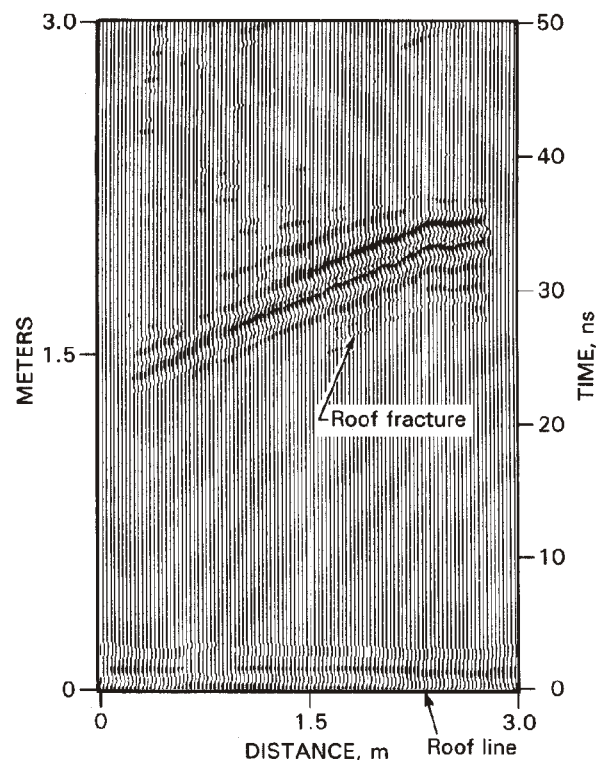

Figure 8.—GPR record at hole No. 2 at Lake Lynn showing crack reflections.

Safety Research Coal Mine

The response of GPR was also tested in the roof of the USEM Pittsburgh Research Center's Safety Research Coal Mine (SRCM) at Bruceton, Allegheny County, PA, in the Pittsburgh Coalbed. Its roof has been well documented. It typically consists of 15.2 cm (6 in) of head coal, 0.9-1.5 m (3-5 ft) of interbedded coals and shales, 1.8-2.4 m (6-8 ft) of sandy shale, and >0.9 m (>3 ft) of sandstone. This site was chosen because there are no constraints on access. Additionally, a 5.1-cm (2-in) corehole was drilled to 4.6 m (15 ft) in the roof to verify radar records. Figure 12 shows the mine layout and the GPR survey site, as well as the confirmation corehole. Several different radar parameters were used to gather data. These include 300-, 500-, 900-MHz antennas, static (stationary) and dynamic (moving) tests, and expanded scales with reduced ranges. Figure 13 shows the roof lithology at the location of the radar surveys determined by roof core. Two features are prominent. First is a typical rider coalbed from 0.3-0.8 m (1-2.5 ft) into the roof. Secondly, a sandstone bed occurs from 4.0-4.6 m (13-15 ft) up into the roof. Both of these beds may be expected to be good reflections and be prominent on the radar record.

The 900-MHz antenna generally provides the best resolution, but sacrifices depth of penetration. It seems best suited to zones of 0.9-1.2 m (3-4 ft) into the roof (figure 14). The higher frequency radar detects discontinuities (most likely bedding) within the strata and generates numerous reflections. These minor reflections may be mistaken for significant features, like faults or lithology changes. Additionally, no prominent reflections are present to signify the rider coal seam. The rider seam may be important for strata control for several reasons, including bolt anchorage and potential head coal.

Figure 15 is a radar record made with a 500-MHz antenna, which has a range of 3 m (10 ft). Starting at the roof line (0 m), the black band is the initial pulse reflection. Above that, a reflection band represents the rider bed at 0.3-0.9 m (1-3 ft). Again, the rider sequence shows as a smeared-out band instead of the sharply defined boundaries of the rider bed. A low-angle bedding shear at approximately 2.1 m (7 ft) corresponds to a weak reflection, but this could be coincidental. Reflections throughout the record above 0.8 m (2.5 ft) do not represent significant discontinuities and, therefore, in the absence of ground truth could be misinterpreted.

Figure 16 is a record generated by a 300-MHz antenna with a range of 6.1 m (20 ft) into the roof. This antenna theoretically has the poorest resolution, but has the greatest range. The overlay shows an offset correlation of the rider bed with the radar record. At 4-4.6 m (13-15 ft) up into the roof, there is a sandstone bed. As a reflector this bed should stand out. There is a good reflector in the general vicinity at 3.8 m (12.5 ft), just offset from the location of the sandstone.

An explanation for this offset and others is that the assumption of using one dielectric constant for the entire roof sequence is not a good one. There are numerous rock types in the sequence with presumably different dielectric constants. A more accurate measure of their electric properties may allow more accurate matching of the lithology to the travel time GPR record.

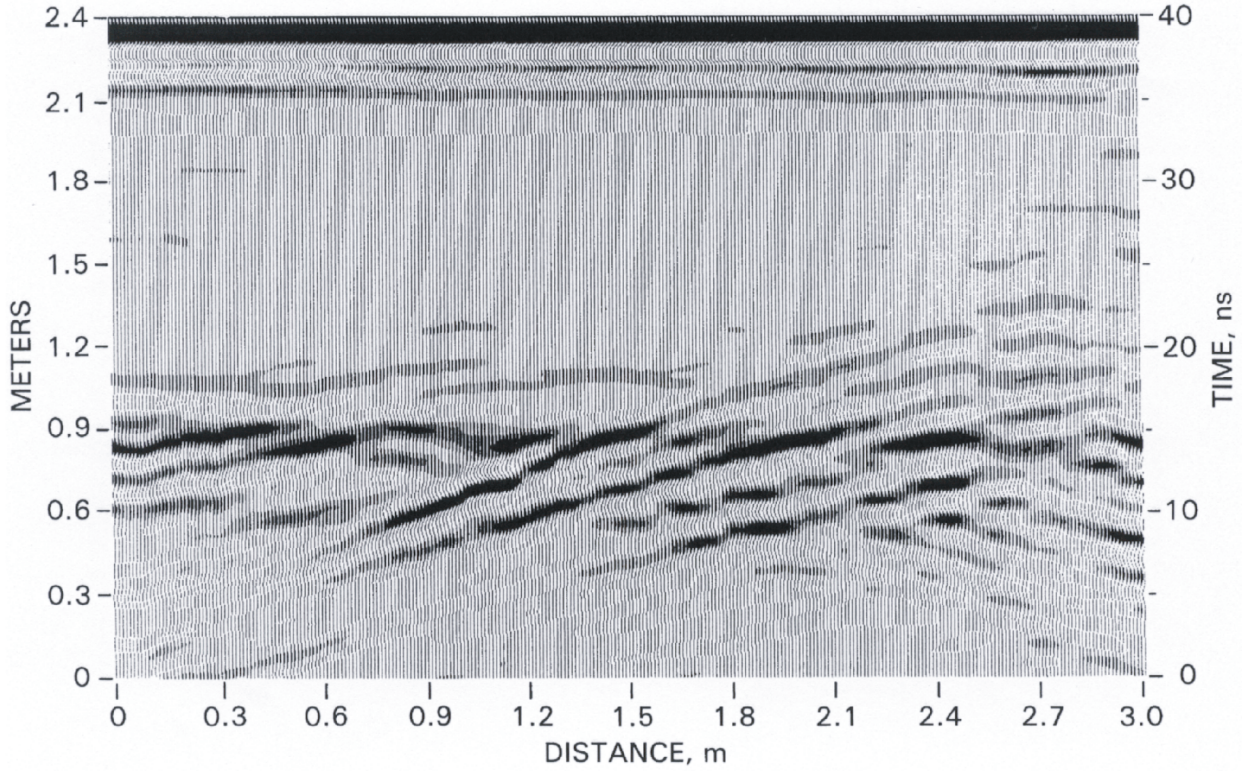

Figure 9.—GPR record at hole No. 3 at Lake Lynn.

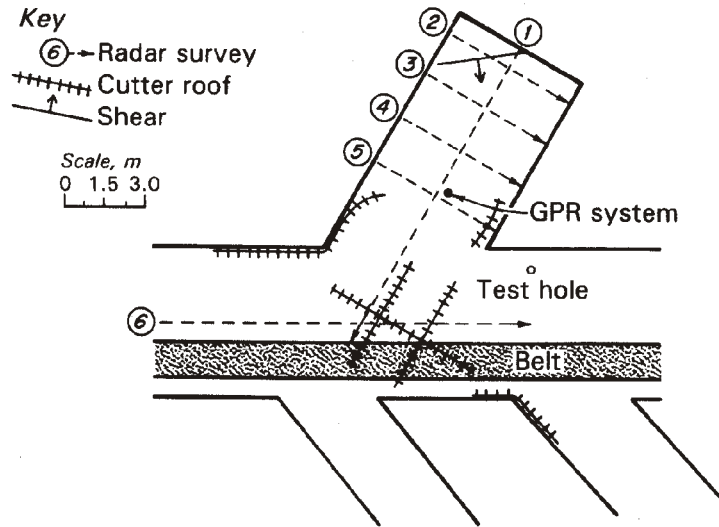

Figure 10.—GPR survey lines and roof damage at RoxCoal Coal Mine.

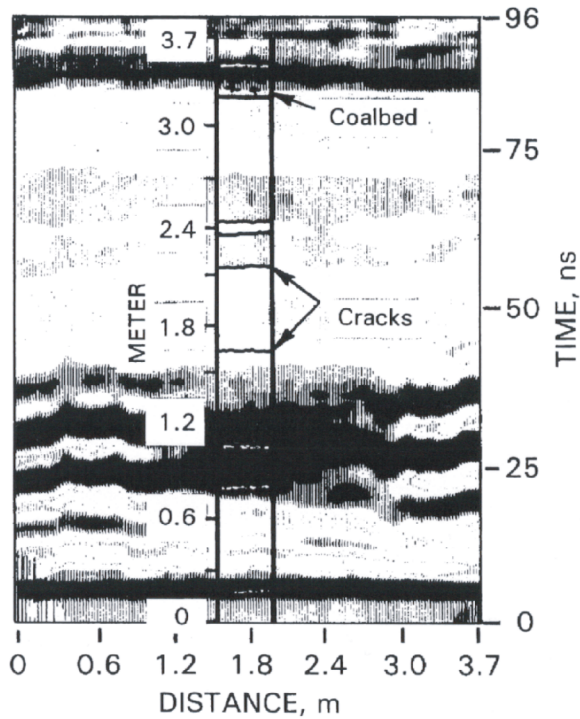

Figure 11.—GPR record of immediate roof at location 4 in RoxCoal Coal Mine with lithology and roof cracks from stratascope hole overprinted.

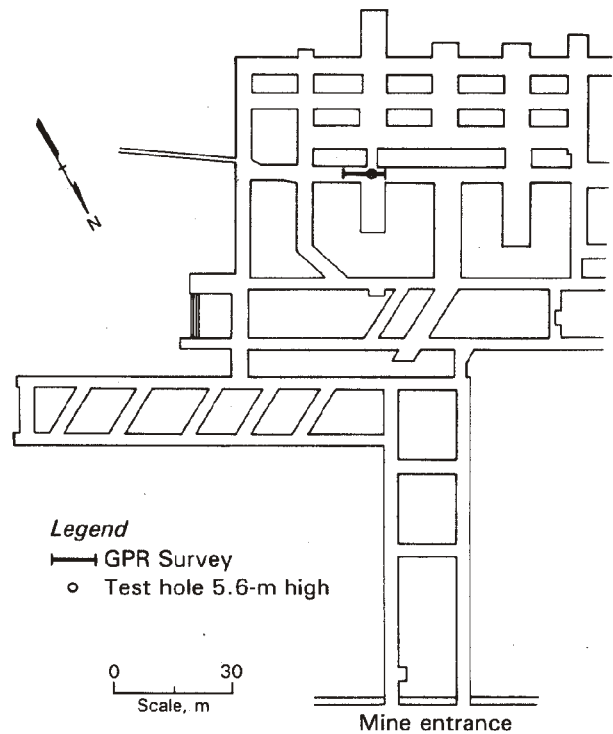

Figure 12.—GPR survey line and corehole in immediate roof at the Safety Research Coal Mine (SRCM).

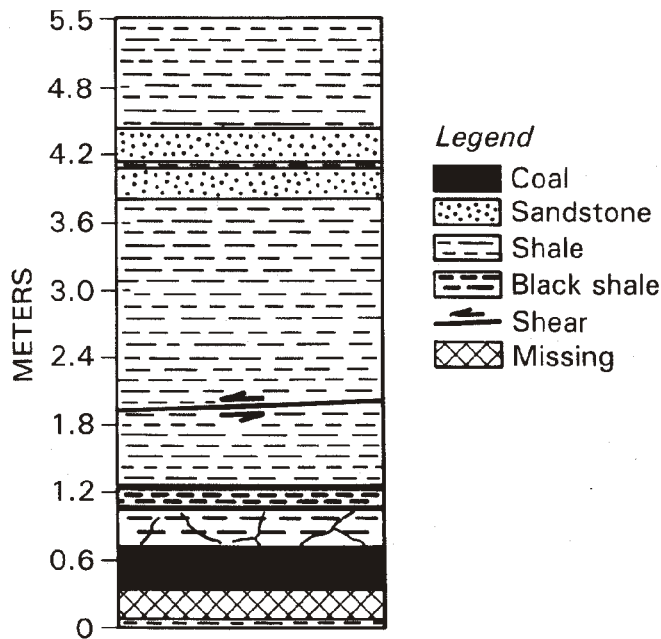

Figure 13.—Lithology in the immediate roof at the SRCM.

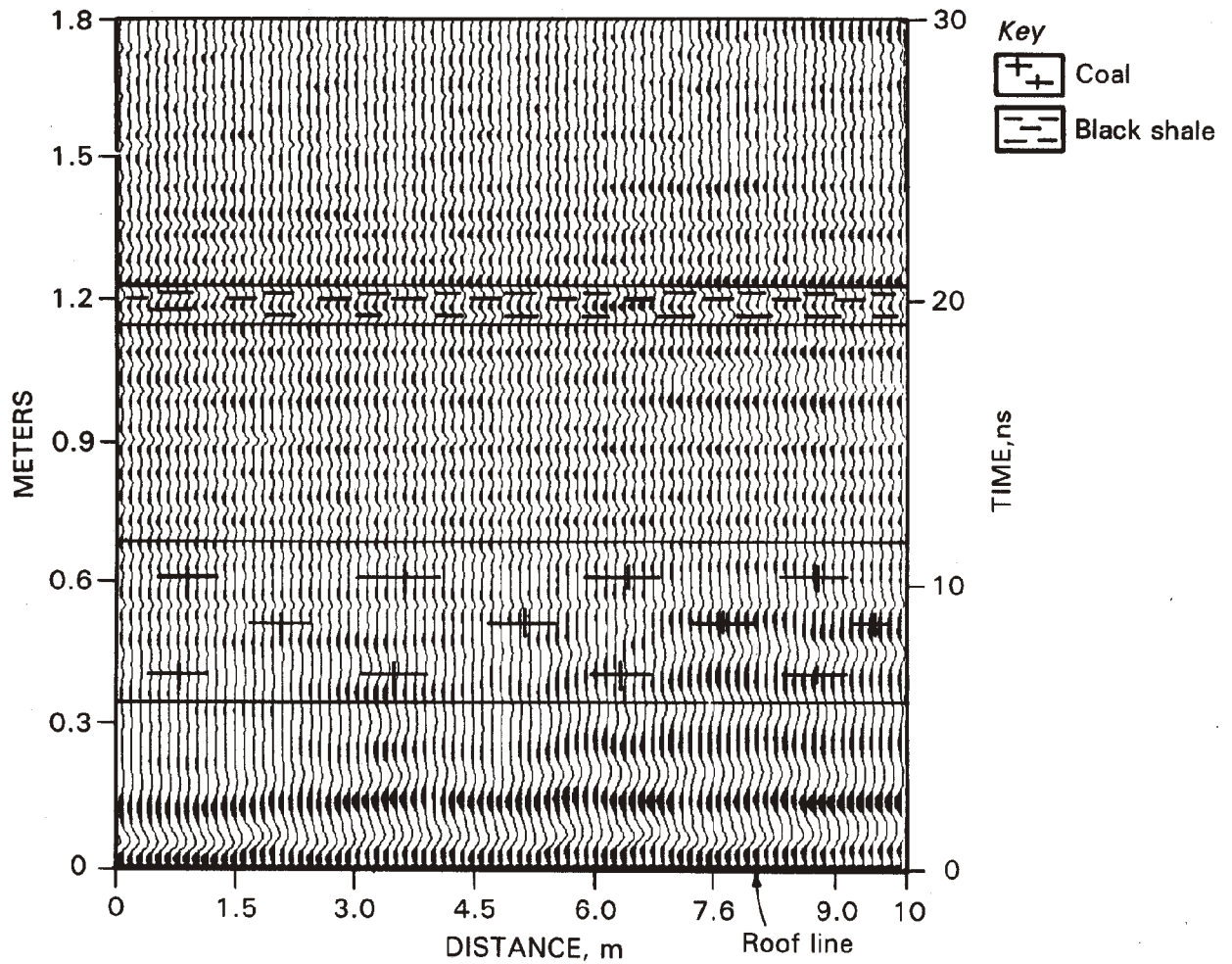

Figure 14.—600-MHz GPR record at the SRCM with overlay of lithology.

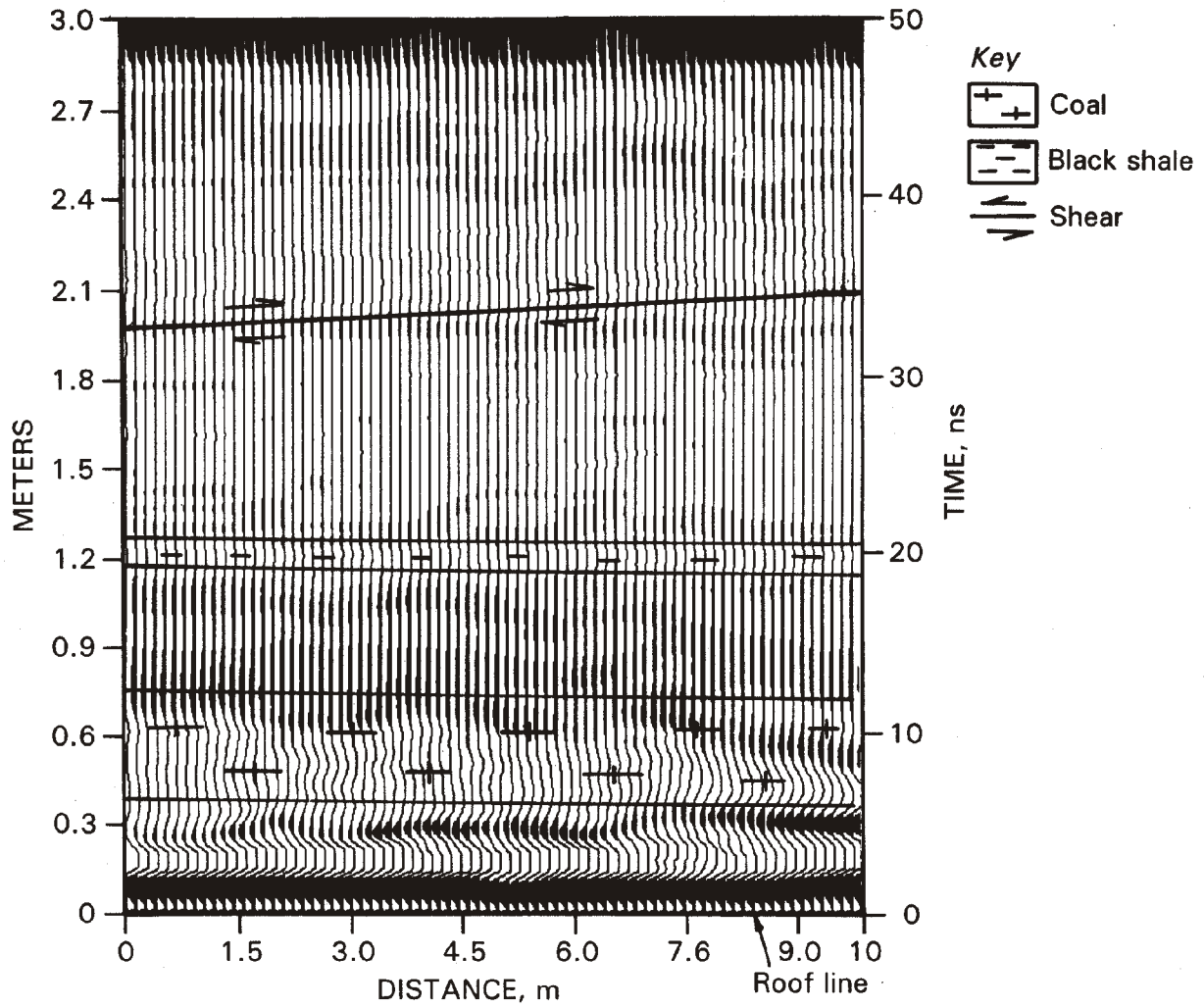

Figure 15.—500-MHz GPR record at the SRCM with overlay of lithology.

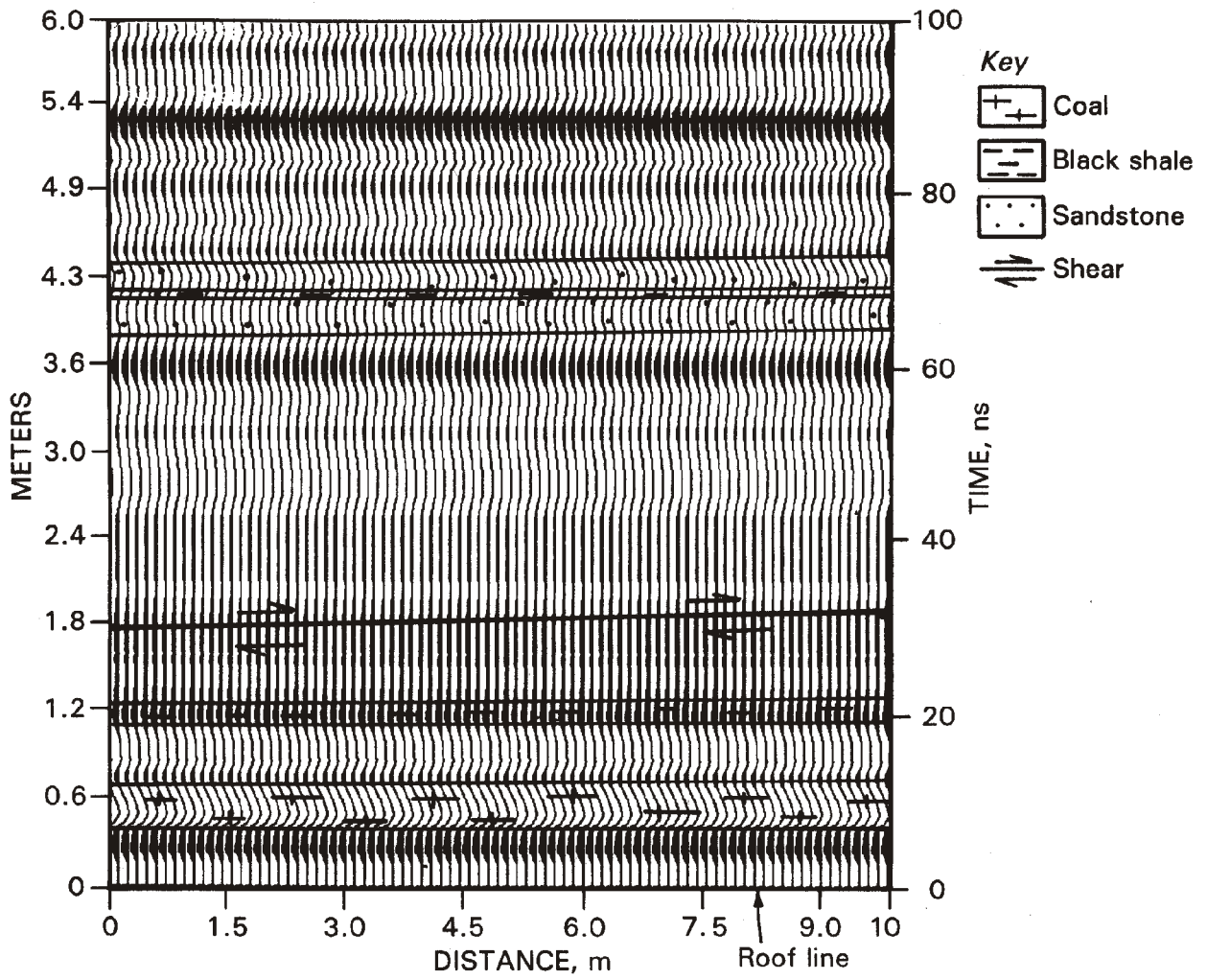

Figure 16.—300-MHz GPR record at the SRCM with overlay of lithology.

APPLICABILITY OF GPR TO COAL MINE ROOF HAZARD DETECTION

As mentioned earlier, the ideal hazard detection system would be able to—

1. Detect significant lithologic changes;
2. Detect bed separations of at least 6.4 mm (0.25 in) and more;
3. Detect large structural discontinuities such as faults, shears, and paleochannels.

The GPR system that was tested is best suited to detect large horizontal bed separations, or by projection, large structures in general. For example, at the Lake Lynn limestone mine, the large bedding separation and fracture zone (1.27 cm (0.5 in) thick) at 1.7 m (5.5 ft) into the roof was easily seen (although as a zone, not a clean fracture). This fracture was also a water-bearing feature, which may have helped enhance the contrast of this feature from the surrounding limestone. The fact that the roof was a single medium (limestone) also allowed the discontinuity to stand out in contrast on the radar record. Conventional coal mine roof strata monitoring typically measures dilation or strata separation in one-tenths of an inch at up to 20 locations vertically in the roof. Better GPR resolutions are needed to match this precision. The tendency for GPR to represent a discrete bed separation as a zone also obscures the precise location of the feature. Closely spaced separations are smeared into a zone instead of clearly defined by the GPR system used in the investigation.

Paleochannels are large structures that can seriously degrade the strength of roof strata. These lenticular features can occur abruptly at high angles or gradually at low angles. Often, they are filled with sandstone, which would appear to be a high-contrast material, but just as often they are filled with siltstone or shale, which would not be in great contrast with normal roof rock. The sandstone bed at approximately 4.3 m (14 ft) up in the roof at the SRCM was detected, but its location indicated by its reflection was 15.2-30.0 cm (6-12 in) lower than actual location. Under these conditions, it is questionable whether an acceptable percentage of paleochannels would be successfully predicted.

Unfavorable lithologic changes in the roof can present roof hazards (e.g., thick riders or claystones, thinning stiff members). At the RoxCoal site, the rider coalbed was correctly detected by GPR at its approximate location, but its thickness and precise location (relative to bolt horizon) could not be measured because of the quality of the data. It appears that coal/rock interfaces are in sufficient dielectric contrast to be detected by GPR, but rock/rock interfaces (e.g., shale/siltstone) do not have dielectric constants of sufficient contrast to make good reflective interfaces. Thus, with the quality of data currently generated, complete lithologic tracking will be difficult.

One possible approach to strata sensing with GPR might be to "train" the software to recognize a potentially hazardous mine roof situation and alert the machine/operator when such a condition is met. With this approach, it would be unnecessary to

understand the geologic associations, but only to "recognize" one of perhaps several undesirable GPR records. For example, a hypothetical hazard No. 1 is a situation where a bed separation of greater than 6.4 mm (0.25 in) occurs anywhere within the first 2.4 m (8 ft) of roof. In the event of this occurrence, a warning (audible or visual) would be sounded. To calibrate the warning system, a GPR record must be generated somewhere in the mine where this situation is known to exist (via instrumentation or optically through a stratascope log). This "type" record would exist in software memory, and any time a match is detected in normal monitoring, a hazard alert would be given. A library of such records could be compiled for each individual mine. This approach would be very specific to each mine and would require a calibration of any sensing package at the outset of application.

Presently, there are a few barriers to a GPR application for roof hazard sensing. Interpretation of the records currently relies on visual picks of either the lineup of high-amplitude peaks of parallel traces or the identification of unusual parts of the waveform of individual traces. This interpretation needs to be standardized to a point where recognition of significant events is triggered by a "threshold" amplitude. This is standard practice in the interpretation of downhole geophysical logs. For example, coalbeds are identified when the density log goes lower than a certain threshold. This objective methodology would take some of the guesswork out of interpretation.

Perhaps more important than interpretation, the quality of data being generated needs to be improved. Material contrasts determine reflective horizons. The material properties of the rocks cannot be changed. The character of the source radar energy may need to be changed. Additionally, the way reflected energy is recorded and presented could be enhanced to highlight subtle material property changes. Current "postprocessing" can enhance records, but this practice needs to be standardized. The GPR records from the four field sites all showed lineups of variable area traces, which amounted to "false bedding." Even when it was known that bedding was nonexistent (e.g., limestone at Lake Lynn), these reflectors were recorded. This false bedding confuses the interpretation and detracts from "real" reflective surfaces. Perhaps a high/low pass filter could remove some of this reflected energy and record only significant events.

Another improvement may be the use of more accurate material property values, such as dielectric constant. The dielectric constants recommended are, for the most part, taken from soils instead of hard rocks. The variation in velocities within the common coal measure rocks may well be significant. The improved accuracy from using velocities from samples from actual roofs may make the interpretations much better. The only way to currently determine if this is a significant variable is to test representative coal measure roof rocks in situ and on cores in the laboratory. Future radar advances promise an in situ determination of dielectric constant by moving the radar antenna toward the roof and a frequency survey over a broad range at each step.

CONCLUSIONS

GPR surveys were conducted at four field sites to determine the value of GPR for detection of roof separations, defects, or lithologies that might lead to hazardous mine roof failures. All surveys were supported with roof cores or stratascope holes for confirmation of radar results. With the present system (SIR-2), the most successful survey results occurred at the Lake Lynn limestone mine and RoxCoal Coal Mine. At Lake Lynn, a relatively large (1.27 m (0.5 in)) bed separation zone was detected by GPR at 1.5-2.4 m (5-8 ft) up in the roof. This was confirmed in three local stratascope holes. At Roxcoal Coal Mine, several cracks were detected at 0.6-0.9 m (2-3 ft) into the roof. Also, at 3.4 m (11 ft) into the roof a 30-cm (12-in) rider coalbed was indicated. This was also confirmed by stratascope.

Although success was reported in these instances, there were several ambiguous or unsuccessful cases in the form of missed cracks or lithologies. At the SRCM, a rider coalbed (0.6 m (2 ft) thick) and sandstone bed (0.6 m (2 ft) thick) were vaguely detected by GPR. At the Collier Stone Quarry, the interfaces between stone slabs were detected, but sharp boundaries were

difficult to discern. Several instances of "false" bedding were interpreted from the data (e.g., RoxCoal Coal Mine).

Three areas govern the usefulness of GPR for mine roof hazard detection. First, the quality of the data collection is determined by the instrument components, the type of radar pulse used, and signal enhancement (gain, filtering). Second, postprocessing enhancement of the radar record can highlight significant reflectors. Third, interpretation of the GPR record will assign physical structure (e.g., lithology, bed separation, etc.) to the reflections. All of these areas should be addressed as variables for study, but interpretation remains one of the most difficult. Perhaps the most productive direction for GPR development may be in calibrating the instrumentation on well-defined, well-documented structures (e.g., sandstone channels, bed separations, coalbed/rock interfaces). By looking for a limited number of specific structures, interpretation of GPR records will become more manageable.

With future development, GPR appears to have potential application as a fast, noninvasive, high-coverage roof hazard detection system.

REFERENCES

1. Peters, R. H. (comp.) Improving Safety at Small Underground Mines. Proceedings: Bureau of Mines Technology Transfer Seminar. USBM Spec. Publ. 18-94, 1994, 174 pp.
2. MSHA REAP Statistics, July 6, 1995. Available from Tony Turyn, Roof Evaluation - Accident Prevention (REAP) Coordinator, MSHA, 4015 Wilson Blvd., Arlington, VA 22203.
3. Chi, D. N. H., and B. Hamilton. Trends in Mining Accidents and Their Costs (1975-1989). Part 1: Breakdown by Mining Areas. Presented at the 19th International Symposium on the Application of Computer Methods in Mineral Industries, PA State Univ., University Park, PA, Apr. 14-18, 1986, 26 pp. Available from G. M. Molinda, Pittsburgh Research Center, Pittsburgh, PA.
4. Iannacchione, A. T., T. P. Mucho, and L. J. Prosser. Ground Control Problems in the Underground Limestone Industry. Presented at the Proceedings of the Environment, Safety, and Health Forum (National Stone Assn.), Nashville, TN, Oct. 22-24, 1995, and the Pennsylvania Ground Control Seminar, Somerset, PA, Nov. 1, 1995, 16 pp. Available from A. T. Iannacchione, Pittsburgh Research Center, Pittsburgh, PA.
5. Daniels, J. J., and R. L. Roberts. Ground Penetrating Radar for Geotechnical Applications in Geophysical Characterization of Sites (ed. by R. D. Woods). Balkema, 1994, pp. 1-13.
6. Subsurface Interface Radar Systems. Training Notes. Geophysical Survey Systems, Inc., v. 1.1, Mar. 1991, 27 pp.
7. Mowrey, G. L., C. W. Garal, and W. D. Monaghan. A Radar-Based Highwall Rib Thickness Monitoring System (Denver, CO). SME preprint No. 95-163, 1995, 8 pp.
8. Mowrey, G. L. Ground Penetrating Radar and Infrared Thermography Tests at a Burning Coal Waste Bank. Paper in Proceedings of the National Assoc. of Abandoned Mine Lands Program, 17th Annual Conf., French Lick, IN, Oct. 18, 1995, pp. 87-105.