

Patent Guide

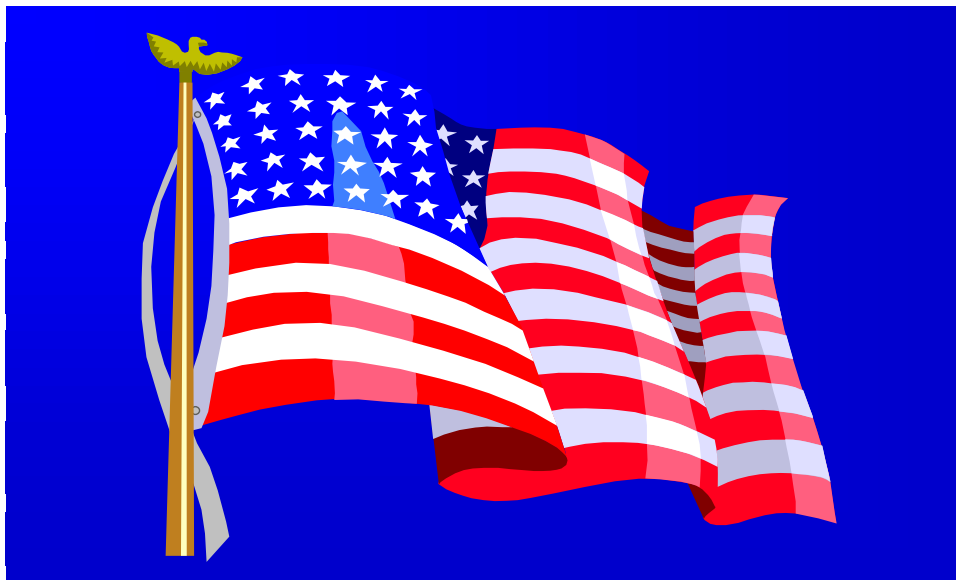

**Office of the Command Counsel
U.S. Army Materiel Command**



May 1997

This guide is intended for government scientists and engineers who receive intellectual property law services from the Office of the Command Counsel, Headquarters, United States Army Materiel Command.

This guide was prepared by the HQ AMC Intellectual Property Law Team with the support of the Army Research Office. The team recognizes the significant contributions of Ms. Rebecca Hayes, IP Team legal secretary, in the preparation of this guide.

Visit us on the Word Wide Web at:

http://amc.citi.net/amc/command_counsel

What is a Patent?

Congress established the U.S. patent system pursuant to the Constitutional provision that gives Congress the power to promote the progress of science and useful arts. The Federal Government promotes new ideas by rewarding inventors with patents for their useful discoveries.

A **patent** is the legal right, for a limited term, to **exclude others** from making, using, offering for sale, selling, or importing an invention or discovery without the patent owner's permission. The term of a U.S. patent is twenty years from the date the patent application is filed with the U.S. Patent and Trademark Office (USPTO) (except design patents, which have a fourteen-year term from the date of issuance of the patent).

There are three types of patents—utility patents, design patents, and plant patents. Utility patents are the most common type of patent obtained by the Army.



What Can Be Patented?

1. Utility Patents—For inventions of any new and useful process, machine, manufacture, or composition of matter, or any new and useful improvement thereof:

- **Process**—Manipulation of a material to cause a change to the material treated by the process. Method of accomplishing a result through a series of steps involving physical or chemical interactions.
- **Machine**—Device with a multitude of moving parts that function together to achieve a particular result; may also be an electrical circuit.
- **Composition**—Any combination of matter.

- **Manufacture**—Any thing made by man, not otherwise classified as a machine or composition.
- 2. Design Patents**—For a new, original, and ornamental design for an article of manufacture. *The design has nothing to do with the article's operation or function, but only its external appearance.*
- 3. Plant Patents**—For distinct and new varieties of asexually reproduced plants, including cultivated sports, mutants, hybrids, and newly found seedlings (other than a tuber propagated plant or a plant found in an uncultivated state).

Table of Contents

What is a Patent?	1
What Can Be Patented?	1
Who Owns the Rights to Inventions	
Made by Government Employees?	2
Why Should I Report an Invention?	2
How Do I Report an Invention?	3
What Happens After I Report An Invention?	4
Where Can I Get More Information?	5
Enclosures	
Sample Detailed Invention Description	6
Invention Rights Questionnaire, DA Form 2871-R	
Record of Invention, AMC Form 1255-R-E	

CRITERIA—To receive a utility patent, the invention must be:

- **New/Novel**—have been previously unknown to the public.
- **Useful**—possess a specific and significant utility.
- **Nonobvious**—be sufficiently different from what was previously used or described before so that it would not have been obvious to a person having ordinary skill in the technology related to the invention.



Who Owns the Rights to Inventions Made by Government Employees?

The Government owns all patent rights to inventions made by Government employees:

- during working hours; or
- with the use of Government facilities, equipment, materials, funds, or information; or
- with a contribution of time or services of other Government employees on official duty; or
- directly related to, or made in consequence of, the official duties of the inventor;

if the employee is employed or assigned to:

- invent, improve, or perfect any art, machine, design, manufacture, or composition of matter; or
- conduct or perform research or development; or
- supervise, direct, coordinate, or review Government financed or conducted research or development; or
- act in a liaison capacity among governmental or nongovernmental agencies or individuals engaged in such research or development.

This presumption may only be rebutted if the inventor can demonstrate that under the particular circumstances it is inequitable for the Government to own the patent rights to the invention.



Why Should I Report an Invention?

The answer is simple—Government employees are required to report all inventions that they make, whether related or unrelated to their duties, and regardless of whether the invention was made during off duty hours.

The reputation of the Government work force and the prestige of the U.S. Army Materiel Command (AMC) are enhanced by the number of patents that AMC obtains. There are also several benefits that Government inventors reap.

Warning!

Publication or disclosure of your invention to persons outside the Government before a patent application is filed in the USPTO can jeopardize patent protection for your invention. Consult with patent counsel prior to disclosing or publishing.

Government inventors are entitled to receive:

- An initial monetary award of \$200 when a patent application is filed in the USPTO.
- A \$500 award upon issuance of a patent (each joint inventor is eligible to receive a \$250 award).
- The first \$2,000 and thereafter a 20% share of any royalties or other payments that result from the invention being licensed by the Army for commercial use, up to a maximum limit of \$150,000 per employee per year.

In addition, where an invention results in substantial savings to the Government, the inventor may receive a monetary award based upon the actual and projected savings. Furthermore, under some circumstances the inventor may obtain the patent rights in foreign countries. Most important, Government inventors experience the pride and

prestige associated with having their name listed as the inventor on a U.S. patent.



How Do I Report an Invention?

The first step for reporting an invention is to complete both *DA Form 2871–R, Invention Rights Questionnaire*, and *AMC Form 1255–R–E, Record of Invention*. Blank forms are included in the back of this guide.

DA Form 2871–R—if the inventor(s) agrees to assign the U.S. patent rights to the Government, only the first page of DA Form 2871–R needs to be completed. If more than one person contributed to the conception of the invention, each inventor must complete a separate DA Form 2871–R.

Attached to **AMC Form 1255–R–E** must be a detailed drawing(s) and a description of the invention explaining how to make and use the invention. Without a detailed description, the Invention Evaluation Committee and the government patent attorney will be unable to determine whether patent protection is warranted.

The detailed description must be sufficient to allow a person with ordinary skill in the technology to make and use the invention. The detailed description should be prefaced by an explanation of the problem that the invention was designed to overcome. Explain what existed in the technical field before the invention and why those items were inadequate to overcome the problem or why the invention is superior to those items.

- **Mechanical Devices**—The description must consist of an element–by–element description of the mechanical device as depicted by the drawings. Start with one feature of the device and logically proceed through all of the features. Every element and component must be referenced by the number on the drawings. Each item and component must be described individually. State the name of the element, the material from which it is made, and any distinctive characteristics of the element, such as strength, shape and orientation. Describe

the element’s position and how it connects or interrelates to the other elements. Describe what function the item performs. After all elements are described, then explain how the device operates referencing each element.

- **Electrical Devices**—The detailed description would be similar to that of a mechanical device. Follow the electrical signal from input to output. For each electrical component—state its name, characteristics and function, and how it interrelates with the rest of the circuit. Explain how the circuit operates—again start with the input and proceed through the circuit to the output. A schematic diagram should accompany the description for simple circuits. Include a block diagram and describe the process depicted by the diagram when helpful to understanding the invention.
- **Chemical Inventions**—The description must explain the method of making and using the compound or composition, and disclose suitable embodiments of the invention. The description must describe and list all suitable starting materials, ingredients, by–products, catalysts, and equipment necessary. Explain the effects of temperature, pressure, time, and pH if they are relevant to the process of making or using the compound or composition.

A sample description is included in the back of this guide. The completed forms should be forwarded to your installation legal office.

Records of Invention

It is important that inventors be able to prove priority of invention. Unless you have dated and witnessed records—preferably in a regularly kept bound laboratory notebook—relating to the conception and disclosure to others (and construction and testing if any) of your invention, some later and less deserving inventor may be able to obtain an effective patent for the same invention.



What Happens After I Report an Invention?

- 1 Your invention disclosure paperwork will be referred to an Invention Evaluation Committee. The committee is composed of several senior technical experts. The committee will evaluate your invention and determine the importance of your invention to the Government.

The government patent attorney will decide, based on the recommendation of the committee, whether the Government will seek patent protection for your invention. Not every invention warrants the expense (\$8,000+) of obtaining patent protection.

- 2 If the Government decides to seek patent protection, the government patent attorney will forward you the formal assignment documents conveying title of the invention to the Government. When you return the documents, the patent attorney will begin preparing the patent application for submission to the United States Patent and Trademark Office (USPTO).

The patent application is a voluminous and extremely important document. You should expect to devote a considerable amount of time assisting the patent attorney.

- 3 When the application is ready for filing in the USPTO, you will execute a Declaration and Power of Attorney. This document gives the patent attorney the power to prosecute the application, and the inventor declares that he or she is the first known inventor.

- 4 About 60 days after receiving the application, the USPTO will issue a “filing receipt.” The filing receipt contains important information such as the filing date and serial number of the patent application.

- 5 Upon receiving the filing receipt, the patent attorney will submit the inventor’s name for an initial award.

- 6 The USPTO gives the application to a patent examiner who is an expert in the technology covered by the invention. The examiner determines whether the application complies with legal requirements and searches prior patents and technical literature to ensure that the invention is new. The examiner then issues an “office action” in the form of a letter that will reflect the official USPTO position on the substantive (i.e., technical) and procedural aspects of the patent application. This office action may reject some or all of the patent claims (i.e., the claimed invention) for various reasons, or may allow some or all of the claims. It often takes 12-18 months before the USPTO issues its first office action.

- 7 The patent attorney prepares, with substantial assistance from the inventor, all responses to USPTO office actions concerning the patent application. The patent attorney’s response, which must address all matters raised by the examiner, will be an amendment in the form of a letter to the USPTO within a prescribed time. The amendment will seek to overcome the rejections by amending the application, possibly canceling some claims and/or pointing out reasons why the USPTO should grant a patent based on all presently remaining claims.

- 8 The examiner then reconsiders the amended application and may reexamine the application. The prosecution continues until the USPTO finally either rejects or allows the inventor’s remaining claims. Usually, the second office action is the final rejection. When all remaining claims are allowed, then the USPTO will grant the patent. This process can take up to three years from the date the patent application is filed with the USPTO.

- 9 If a patent issues, you may be eligible for a final invention award.

The patent attorney will send the issued patent to the respective directorate for presentation to the inventor(s). Our normal practice is to provide the original ribboned copy to the first-named inventor. Copies will be provided to all other co-inventors.

- ⑩ Your invention will be evaluated for licensing potential in the commercial marketplace. If the Government licenses your invention, you will receive part of the royalties.



Where Can I Get More Information?

This guide has presented only a brief discussion of the patenting process. If you have additional questions, please contact your local legal office, which will either answer your questions or refer you to a patent attorney at Headquarters, U.S. Army Materiel Command.



SAMPLE DETAILED INVENTION DESCRIPTION

Stun Gun

In general, the term “stun gun” has been generically applied to any electronic device designed to incapacitate a person by means of nonlethal electric shock to affect the neuromuscular system of the body by interrupting electrical nerve impulses, causing a mild state of confusion or disorientation. Most stun guns have a hardened and nonconductive exterior case in which is housed the electronic circuitry. Generally protruding from the case are preferably two or four probes through which a high voltage, low duration, and low charge pulse, produced by the internal circuitry, is delivered.

Existing stun guns have several significant shortcomings that are overcome by the present invention. There exists a need for a stun gun device having a low battery indicator light to alert an operator that the battery driving the internal electronic circuits have reached the end of their useful life. Further, the market demands a stun gun having a fail-safe shutdown feature wherein an overzealous operator is precluded from applying the device against a victim for prolonged periods. The market further demands a stun gun which is deactivated if stripped away from a law enforcement officer and which is rendered useless to an assailant who may obtain possession of the device without a reactivation component securely strapped about the operator’s wrist or to his or her person. Lastly, the market demands the efficient utilization of energy stored in the battery power source to permit the device to be used for prolonged periods. The present invention fulfills these pressing needs.

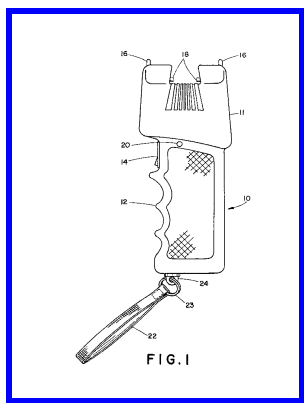
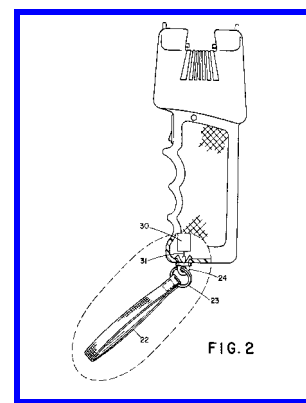

FIG. 1 is a side view of the present invention stun gun showing its wrist strap and low battery indicator light. FIG. 2 is a side view and partial cut-away of the present invention stun gun, showing its disable switch and key components attached to the wrist strap. FIG. 3 is an enlarged view of the dashed portion of FIG. 2, wherein the key portion is received into the device housing. FIG. 4 is an enlarged view of the dashed portion of FIG. 2, wherein the key portion is shown detached from the device housing. FIG. 5 is a circuit diagram of the improved electronic circuitry of the present invention.

Referring first to FIG. 1, the present invention stun gun is shown as 10 and is comprised of a housing 11 having a pistol grip 12 and a trigger switch 14. The trigger switch 14 is located at a position on the housing 11 situated to receive an operator's index finger. Extending from the housing 11 are a pair of contact probes 16 and test probes 18, the pair of contact probes 16 being used to apply the high voltage generated within the housing 11 to an assailant/victim. The housing 11 is provided with an aperture 20 through which the low battery indicator light-emitting diode (LED) may be viewed. At the lower end of housing 11 is a wrist strap 22 through which extends an operator's wrist while gripping the pistol grip 12. As shown in FIG. 1, a ring 23 connects the wrist strap 22 with the key 24, the key 24 shown in its engaged/attached position. As may be apparent to one skilled in the art, other means may be used to attach the key 24 to an operator's person, such as a tether from the ring 23 to an operator's belt loop, shoulder holster, or waist holster.



Referring now to FIG. 2, a portion of the housing 11 is shown cut-away. The key 24 is shown received into the housing 11 and in contact with plunger 31 of switch 30. The switch 30 is fixed mechanically to a

circuit board contained within the housing and not shown in detail.

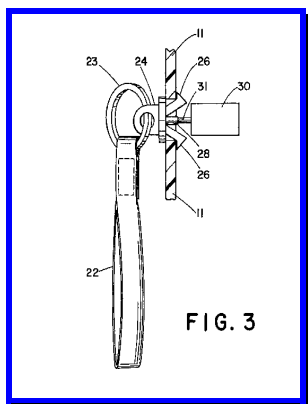
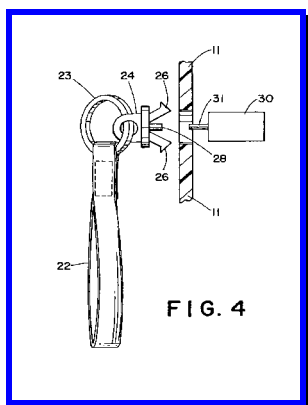

FIG. 3 is an enlarged view of the cut-away portion of FIG. 2 showing the key 24 received into the housing 11. As can be seen from FIG. 3, key 24 is comprised of a pair of barbed, springy legs 26 which, when inserted into the housing 11, serve to "lock" the key 24 therein. The key 24 is also provided with a centrally located fixed plunger 28 arranged to make contact with and slidably actuate plunger 31 of switch 30. The key 24 may be made of a relatively durable plastic such that upon insertion into the housing 11, removal may be accomplished only upon application of a predetermined force on ring 23. The material and dimensions of ring 24 should be selected such that a substantial force should be required to dislodge the key 24 from housing 11.



Referring next to FIG. 4, wherein the cut-away portion of FIG. 2 is shown in an enlarged view, the key 24 is shown detached from housing 11. As seen in FIG. 4, the spring loaded plunger 31 of switch 30 is permitted to slidably extend into its unactuated position in the absence of key 24 and associated centrally located fixed plunger 28. FIG. 4 shows the pair of barbed, springy legs 26 in their unsprung position and ready for reinsertion into the housing 11 to re-enable

the stun gun device upon actuation of plunger 31 into switch 30.

Referring now to FIG. 5, a circuit diagram of the improved electronic circuitry of the present invention is shown. Power is supplied to the circuit from a battery source BT1. The electrical diagrammatic representation of trigger switch 14 is shown as switch SW1, wherein closure of the switch SW1 connects power source BT1 with the inverter transformer T1. In general, a classic relaxation oscillator is formed using a "tickler" winding of inverter transformer T1 shown between the terminals PAD7 and PAD8. The primary winding of the inverter transformer T1 is shown in FIG. 5 having connections at PAD9 and PAD10. Upon closure of the power switch SW1, the primary winding of inverter transformer T1 is energized as current flows through the winding from PAD9 to PAD10 as the power transistor Q1 conducts. The tickler winding of inverter transformer T1 is energized upon closure of the power switch SW1 through resistor R8 and diode D3. The current through the tickler winding also forms the base current of power transistor Q1, thus causing it to conduct. Since the tickler winding and the primary winding of the inverter transformer T1 oppose one another, the current through power transistor Q1 causes a flux in the inverter transformer T1 to, in effect, back drive the tickler winding and cut off the power transistor Q1 base current, thus forming the relaxation oscillator.

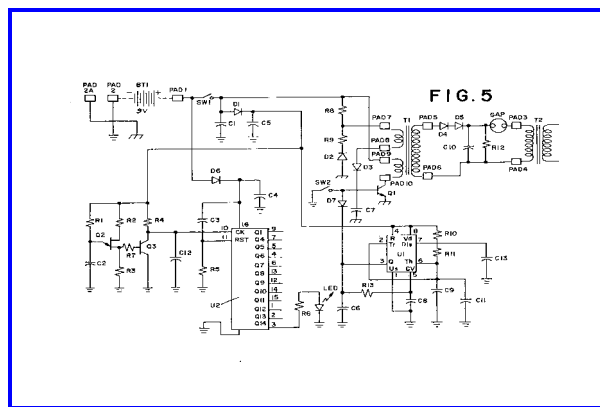

The output circuit of the stun gun of the present invention is shown in FIG. 5 as consisting of the secondary winding of inverter transformer T1, a pair of diodes D4 and D5, serially connected with a spark gap device GAP and the primary winding of output transformer T2. A storage capacitor C10 is shown in parallel with bleeder resistor R12 and the primary

winding of the output transformer T2. The bleeder resistor R12 is provided to discharge the storage capacitor at a slow rate to prevent accidental discharge of the device once power has been removed.

The spark gap device GAP is selected to have particular ionization characteristics tailored to a specific spark gap break over voltage to "tune" the output circuit. The spark gap device GAP is filled with an inert gas such as argon, having a well defined and generally stable permittivity constant to ensure predictability of the spark gap break over point voltage. In the preferred embodiment, the output transformer T2 is formed having a 26:1080 turns ratio with a primary winding resistance of 0.04 ohms and a secondary resistance of 108 ohms.

Technical evaluation of the circuit of the present invention shows that the electrical output waveform of the device is a repeating damped sinusoid with a repetition rate of approximately 20 pulses per second. The principle frequency component of the sinusoid is approximately 1 MHZ. Using the above-described combination of spark gap device and output transformer, the peak voltage present at the electrodes when the output is connected to a resistive load which drops the unloaded voltage to half is approximately 50,000 volts. This measure of source impedance is about half that of similar stun guns on the market today. The physiological effect of this reduced source impedance is to increase the magnitude of the electrical current impulses or energy delivered to a subject/victim and thereby increase the effectiveness of the stun gun in practical application.

With continued reference to FIG. 5, the low battery indicator feature of the present invention is shown. A 14 stage ripple carry counter U2 receives power from power source BT1 through diode D6. A charge is stored on capacitor C4 to provide power to the 14 stage ripple carry counter U2 in the event of temporary power interruptions, such as if the device is dropped or the like. In the event that the batteries are removed and power is lost for a prolonged period, the 14 stage ripple carry counter U2 will reset and lose its count as the reset input RST is taken to ground through resistor R5.

Upon closure of power switch SW1, an oscillator comprising semiconductor devices Q2 and Q3 is enabled which provides the 14 stage ripple carry counter U2 with a series of pulses through clock input CK. As seen in FIG. 5, anytime power switch SW1 is

held closed, the 14 stage ripple carry counter U2 continues to increment its count stored therein. At such time that the count stored within the 14 stage ripple carry counter achieves a predetermined value, an output signal Q14 goes high, driving a LED thus alerting the operator that the length of time of use of the batteries comprising the power source BT1 has exceeded a recommended value, typically 20 minutes. Since the above-described low battery indication circuit functions as a counter, and not as an actual evaluation of the batteries comprising the power source BT1, it must be agreed before hand by all using the device that, when replacing batteries, only new batteries will be used because the 14 stage ripple carry counter U2 loses its count upon removal of the batteries from the device. Thus, the 14 stage ripple carry counter U2, unaware of the quality of the replacement batteries, will by virtue of the reset input RST, start to count from a "zero" count anytime the batteries are removed and replaced.

The built-in shutoff feature of the present invention is shown in FIG. 5 and comprises a timer integrated circuit chip U1 of the type commonly referred to as "555 timer." As shown in FIG. 5, the integrated circuit chip timer U1 is arranged to operate in a stable condition wherein upon closure of power switch SW1, power is applied to the chip U1 through input pins R and Vd. After a predetermined time period of approximately 15 seconds, the timer integrated circuit chip U1 operates to lower output signal Q to a low logic level, thus causing diode D7 to conduct whereby power transistor Q1 is forced into its nonconducting state. With the power transistor Q1 in its nonconducting state, the oscillator stage will not function and, thus the output circuit is rendered ineffective. A continuous closure of power switch SW1 will act to maintain power to the timer integrated circuit chip U1 and after a predetermined time of approximately 5 seconds, the output Q is again returned to its original high logic state wherein diode D7 becomes reverse biased, thus re-enabling power transistor Q1.

Lastly, as shown in FIG. 5, the electrical diagrammatic representation of switch 30 is shown as SW2. Upon insertion of key 24 into housing 11, switch SW2 is opened as shown in FIG. 5. When the key 24 is removed from housing 11, switch SW2 closes thus tying the base of power transistor Q1 to ground. This, in effect, disables the relaxation oscillator and in turn disables the device.

