



Supporting The Acquisition Process: T&E Modeling & Simulation



RADM Rodney P. Rempt

September 1997

ROLLING AIRFRAME MISSILE (RAM) MODEL-TEST-MODEL



What are we doing?

- Building a RAM Blk 1 launcher simulator
- Conducting validation testing of the simulator vs. real launcher
- Conducting risk reduction testing in support of upcoming TECHEVAL/OPEVAL on GUNSTON HALL LSD 44
- Supporting Land Based Engineering Facility (LBEF) testing Oct/Nov 97

Why are we doing it?

- To enable testing or training at facilities requiring a RAM Blk 1 launching system
- To test RAM Blk 1 interfaces with other combat systems

What are the benefits?

- Streamlines engineering development
- Enables early end-to-end testing of total combat system
- Saves \$4.2M per launching system
- Increases training efficiency

*M&S supports at-sea testing to achieve
a successful Milestone III*

WRAP-AROUND SIMULATION PROGRAM (WASP)

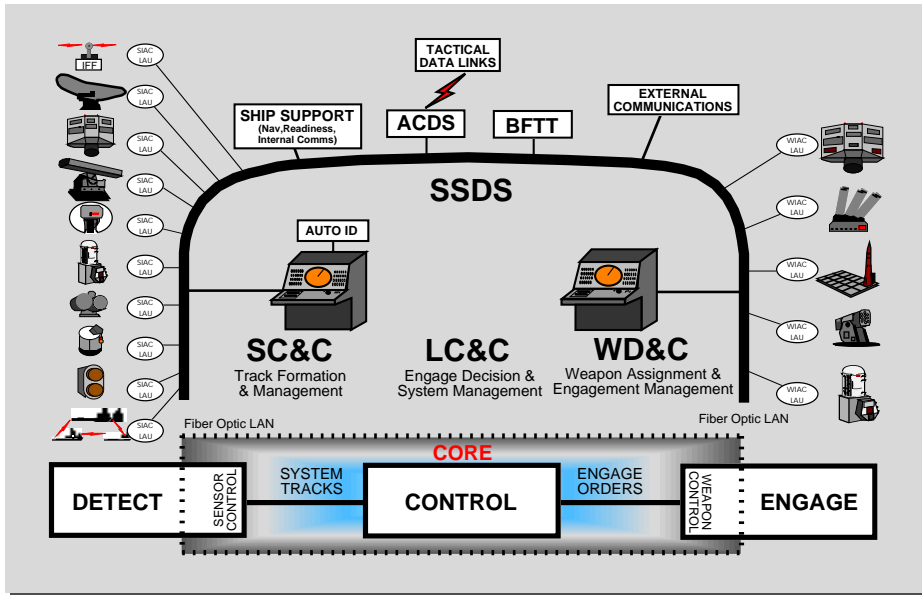

What are we doing?

- Conducting elemental model integration
- Stimulating Ship Self Defense System (SSDS) tactical hardware and software
- Supporting Fleet Quick Reaction Combat Capability engagement doctrine development
- Performing risk reduction testing in support of AT-SEA testing aboard USS ASHLAND LSD 48

Why are we doing it?

- To accomplish risk reduction
- To reduce at-sea testing cost
- To stress the software prior to Fleet introduction
- To increase statistical sample size of test
- To validate QRCC engagement doctrine

What are the benefits?

- Reduces at-sea testing
 - Validate Fleet SSDS/QRCC doctrine
- Supports Fleet test and training
 - Battle Force Tactical Trainer (BFTT) capable

Enables developmental testing of the total combat system prior to at-sea testing

What are we doing?

- Maximizing effectiveness while minimizing cost
- Developing a process for performance verification in support of MS III
- Integrating M&S, Hardware in the Loop (HWIL), and flight testing
- Validating M&S for use in testing

Why are we doing it?

- To support timely introduction of capability into fleet given existing resources
- To minimize requirements for costly, complex test exercises
- To advance software maturity and leverage HWIL testing

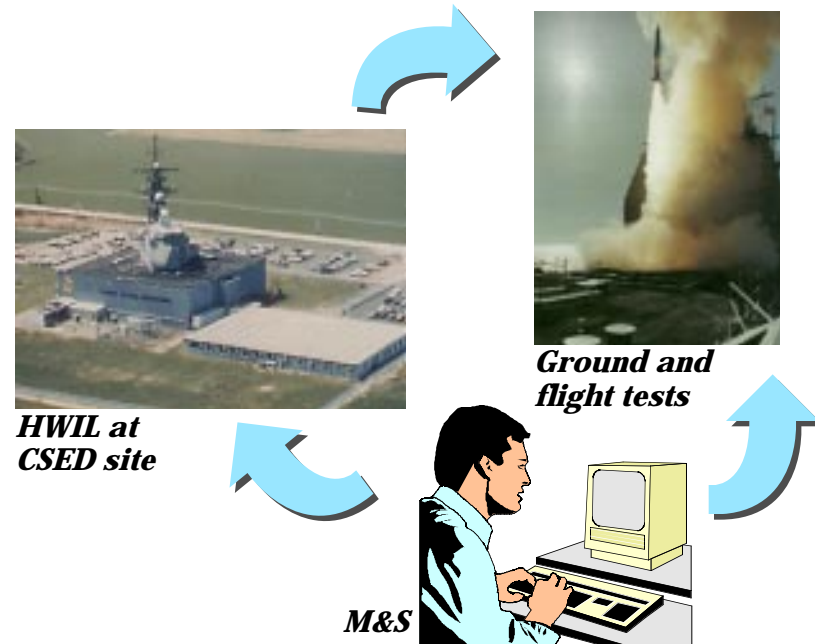

What are the benefits?

- Reduces risk and ensures optimal test planning
- Maximizes use of available flight test data
- Provides credible simulation tools to support system evaluation and acquisition decisions

Incorporates live, virtual and constructive M&S to verify system performance during EMD

INTEGRATED SHIP DEFENSE (ISD) PILOT PROGRAM

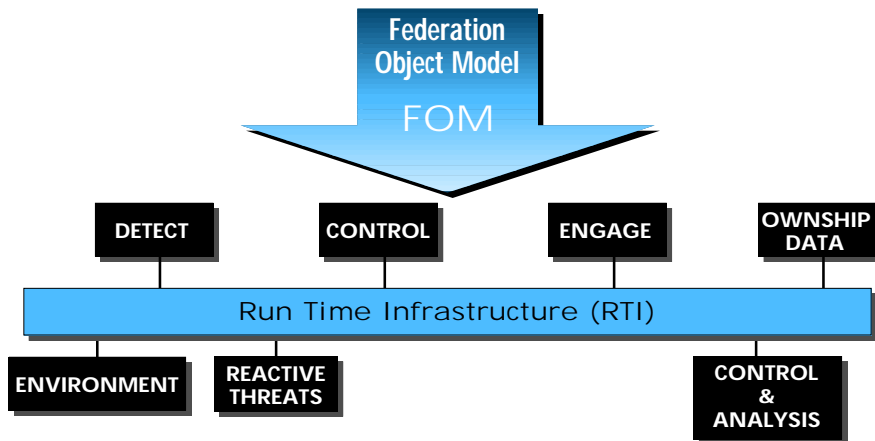

- *Sensor integration/HK-SK interaction analysis*
- *Benchmark capabilities for follow-on application*
- *Demonstrate hi-fidelity model interaction via HLA(RTI)*

Why are we doing it?

- To reduce cost of at-sea testing
- To provide an assessment capability for the total combat system
- To eliminate inconsistencies in environmental/ threat models at the element level

What are we doing?

- Integrating legacy and future element simulations
- Maturing High Level Architecture (HLA) RunTime Infrastructure (RTI) technology
- Developing end-to-end simulation capability during FY98 effort
- Integrating tactical command and control software with system elements

What are the benefits?

- Provides engineering level assessment tool to support the acquisition process
- Maximizes effectiveness of at-sea testing
- Provides an integrated ship defense combat system representation in the joint synthetic battle space (JSTEB)
- Determines readiness and return on investment of embracing HLA standard and Advanced Distributed Simulation technology

*The ISD Pilot is the discovery process
 for the way ahead*

PILOT PROGRAM VISION

ENGINEERING MODELS

- **HK/EW interactions**
- **Hi fidelity**
- **Non-real time**

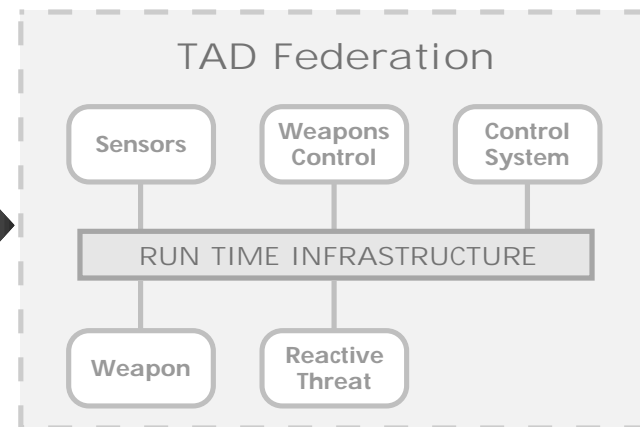
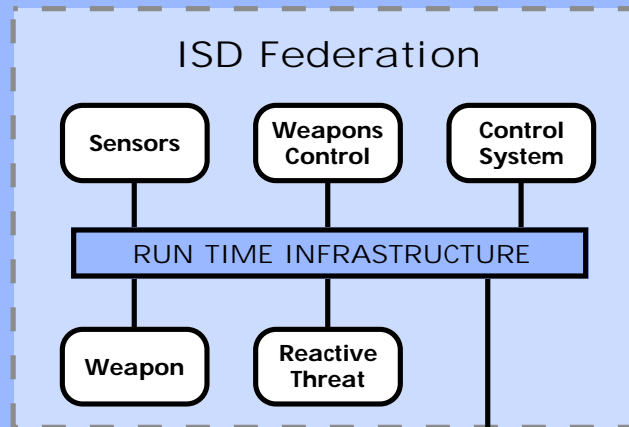

COMMON SERVICES

- Environment
- Scenario
- Simulation Control
- Analysis Tools

**BRIDGE
 FEDERATE**

- **Spatial coherence**
- **Time synchronization**

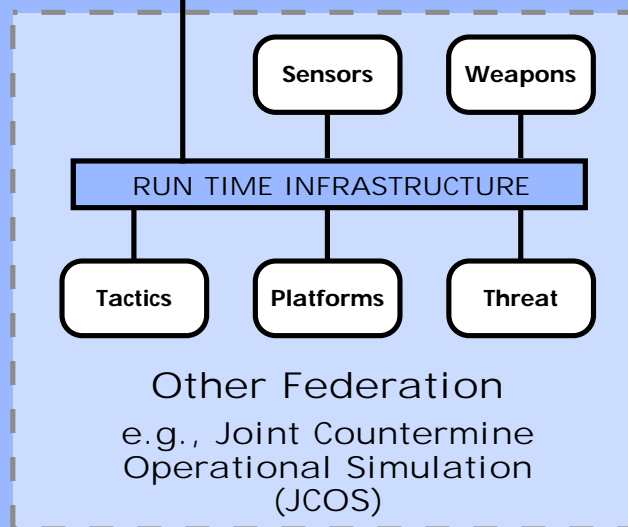

ENGAGEMENT SIMULATION

- **Expeditionary warfare**
- **Multi-warfare/Joint OPS**
- **Mission evaluation of conceptual systems**
- **Real time/event driven**

EVOLVING CAPABILITIES

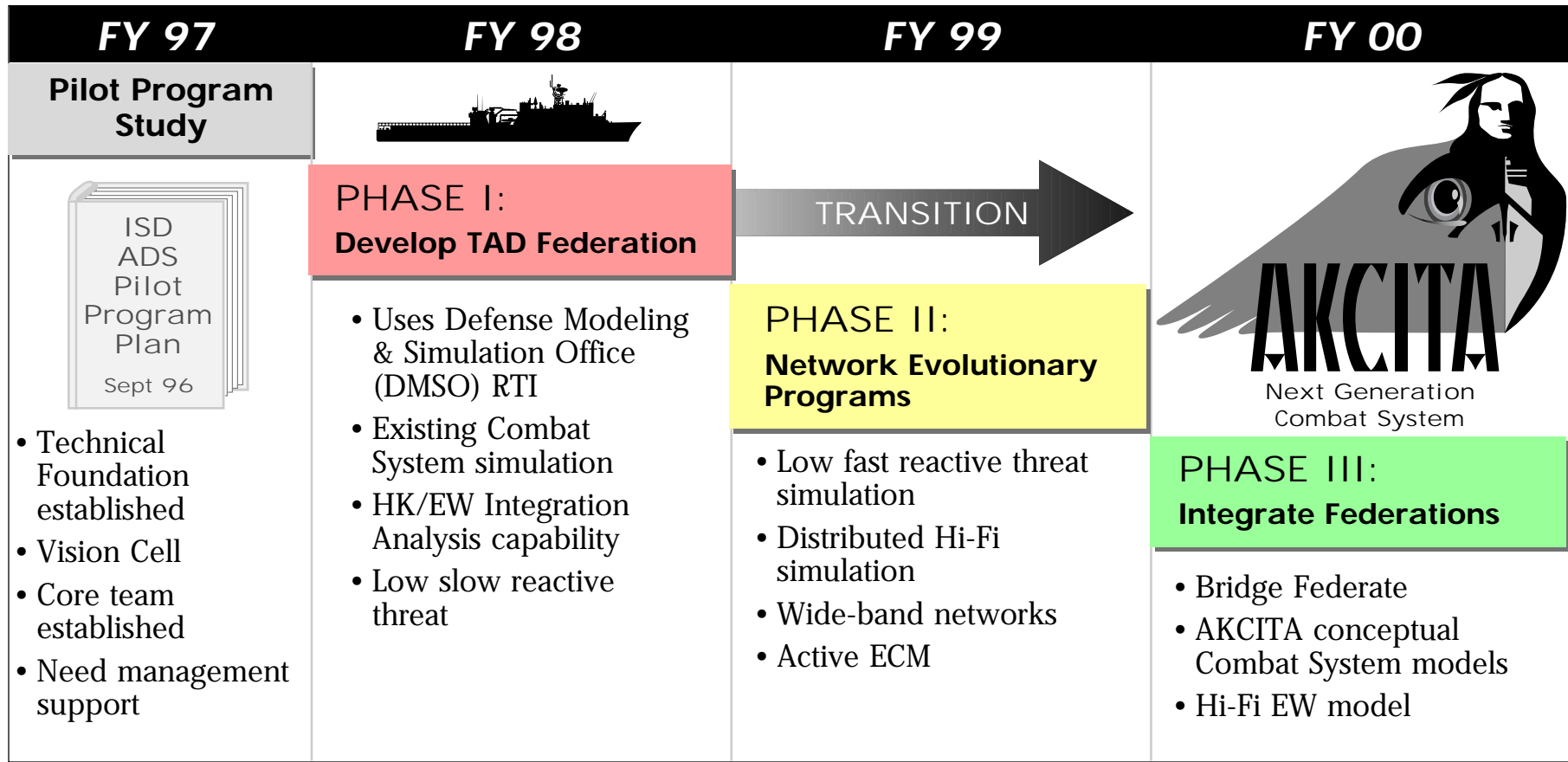

PHILOSOPHY: *Phases transition M&S capabilities of current systems to Next Generation Systems in support of Simulation-Based Acquisition*

PHASE III ARCHITECTURE (FY 00)

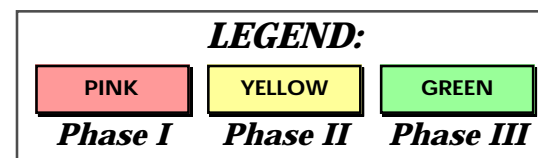
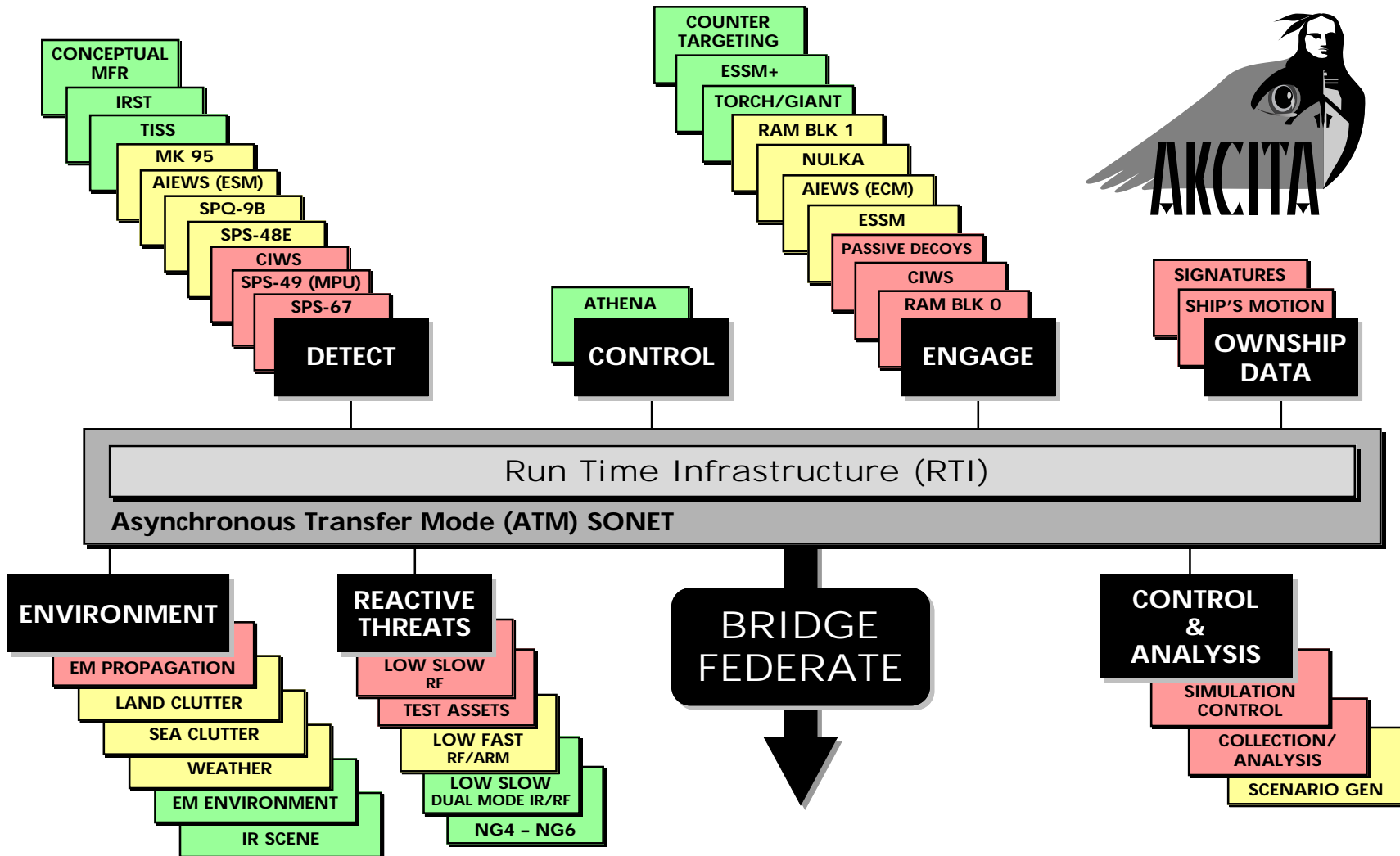

SCHEDULE/COST

FY 97	FY 98	FY 99	FY 00
PHASE I ISD Pilot Program <ul style="list-style-type: none"> Develop a comprehensive Federation Object Model (FOM) Perform conceptual analysis Design the Federation Perform requirements solicitation Design new or modify legacy designs 		PHASE II ISD Pilot Program <ul style="list-style-type: none"> Expand sensor suites Include active ECM Network geographically distributed Federates 	PHASE III ISD Pilot Program <ul style="list-style-type: none"> Connectivity to other Federations AKCITA performance assessment RF/IR reactive threat capability

Total Program

\$24.4 M

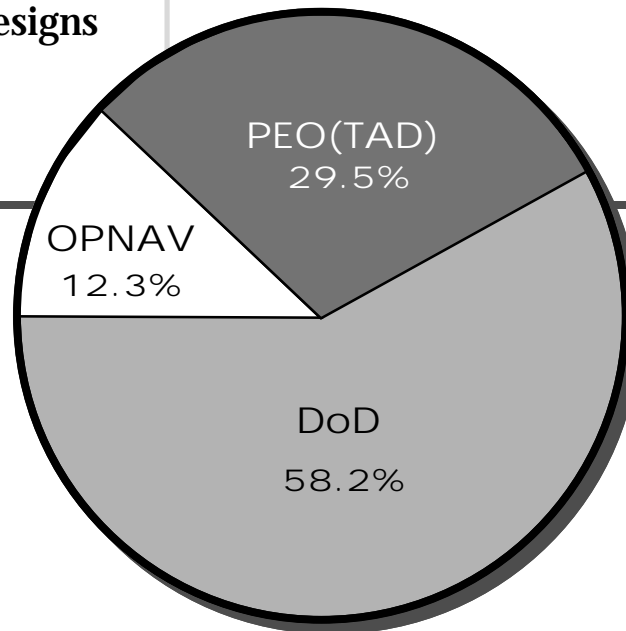

Pooling of resources enables us to proceed

LIVE FIRE vs. M&S

HOW MUCH REDUCTION IS ENOUGH?

- **The driver**
 - Shrinking missile inventories and rising cost and complexity of test
- **The road to the solution**
 - Identified areas where M&S can replace portions of live fire T&E
 - Combat system capability assessment
 - Tactical doctrine development and training
 - Commissioned live fire test reduction study
 - Assessment agent Naval Warfare Assessment Division
 - Establish methodology and process for determining appropriate utilization of M&S
- **Expand process across PEO(TAD)**

TAD is striving toward optimal balance between live fire and M&S