

Leading by example,
saving energy and
taxpayer dollars
in federal facilities

Biomass Cofiring in Coal-Fired Boilers

Using this time-tested fuel-switching technique in existing federal boilers helps to reduce operating costs, increase the use of renewable energy, and enhance our energy security

Executive Summary

To help the nation use more domestic fuels and renewable energy technologies—and increase our energy security—the Federal Energy Management Program (FEMP) in the U.S. Department of Energy, Office of Energy Efficiency and Renewable Energy, assists government agencies in developing biomass energy projects. As part of that assistance, FEMP has prepared this *Federal Technology Alert* on biomass cofiring technologies. This publication was prepared to help federal energy and facility managers make informed decisions about using biomass cofiring in existing coal-fired boilers at their facilities.



The boiler plant at the Department of Energy's Savannah River Site cofires coal and biomass.

The term “biomass” refers to materials derived from plant matter such as trees, grasses, and agricultural crops. These materials, grown using energy from sunlight, can be renewable energy sources for fueling many of today's energy needs. The most common types of biomass that are available at potentially attractive prices for energy use at federal facilities are waste wood and wastepaper.

One of the most attractive and easily implemented biomass energy technologies is cofiring with coal in existing coal-fired boilers. In biomass cofiring, biomass can substitute for up to 20% of the coal used in the boiler. The biomass and coal are combusted simultaneously. When it is used as a supplemental fuel in an existing coal boiler, biomass can provide the following benefits: lower fuel costs, avoidance of landfills and their associated costs, and reductions in sulfur oxide, nitrogen oxide, and greenhouse-gas emissions. Other benefits, such as decreases in flue gas opacity, have also been documented.

Biomass cofiring is one of many energy- and cost-saving technologies to emerge as feasible for federal facilities in the past 20 years. Cofiring is a proven technology; it is also proving to be life-cycle cost-effective in terms of installation cost and net present value at several federal sites.

Energy-Saving Mechanism

Biomass cofiring projects do not reduce a boiler's total energy input requirement. In fact, in a properly implemented cofiring application, the efficiency of the boiler will be the same as it was in the coal-only operation. However, cofiring projects do replace a portion of the non-renewable fuel—coal—with a renewable fuel—biomass.

Cost-Saving Mechanisms

Overall production cost savings can be achieved by replacing coal with inexpensive biomass fuel sources—e.g., clean wood waste and waste paper. Typically, biomass fuel supplies should cost at least 20% less, on a thermal basis, than coal supplies before a cofiring project can be economically attractive.



Payback periods are typically between one and eight years, and annual cost savings could range from \$60,000 to \$110,000 for an average-size federal boiler. These savings depend on the availability of low-cost biomass feedstocks. However, at larger-than-average facilities, and at facilities that can avoid disposal costs by using self-generated biomass fuel sources, annual cost savings could be significantly higher.

Application

Biomass cofiring can be applied only at facilities with existing coal-fired boilers. The best opportunities for economically attractive cofiring are at coal-fired facilities where all or most of the following conditions apply: (1) coal prices are high; (2) annual coal usage is significant; (3) local or facility-generated supplies of biomass are abundant; (4) local landfill tipping fees are high, which means it is costly to dispose of biomass; and (5) plant staff and management are highly motivated to implement the project successfully. As a rule, boilers producing less than 35,000 pounds per hour (lb/hr) of steam are too small to be used in an economically attractive cofiring project.

Field Experiences

Cofiring biomass and coal is a time-tested fuel-switching strategy that is particularly well suited to a stoker boiler, the type most often found at coal-fired federal facilities. However, cofiring has been successfully demonstrated and practiced in all types of coal boilers, including pulverized-coal boilers, cyclones, stokers, and fluidized beds.

To make economical use of captive wood waste materials—primarily bark and wood chips that are unsuitable for making paper—the U.S. pulp and paper industry has cofired wood with coal for decades. Cofiring is a standard mode of operation in that industry, where biomass fuels provide more than 50% of the total fuel input. Spurred by a need to reduce fuel and operating costs, and potential future needs to reduce greenhouse gas emissions, an increasing number of industrial- and utility-scale boilers outside the pulp and paper industry are being evaluated for use in cofiring applications.

Case Study Summary

The U.S. Department of Energy's (DOE) Savannah River Site (SRS) in Aiken, South Carolina, has installed equipment to produce "alternate fuel," or AF, cubes from shredded office paper and finely chipped wood waste. After a series of successful test burns have been completed to demonstrate acceptable combustion, emissions, and performance of the boiler and fuel processing and handling systems, cofiring was expected to begin in 2003 on a regular basis. The biomass cubes offset about 20% of the coal used in the facility's two traveling-grate stoker boilers. The project should result in annual coal cost savings of about \$112,000.

Cost savings associated with avoiding incineration or landfill disposal of office waste paper and scrap wood from on-site construction activities will total about \$172,000 per year. Net annual savings from the project, after subtracting the \$30,000 per year needed to operate the AF cubing facility, will be about \$254,000. An initial capital

investment of \$850,000 was required, resulting in a simple payback period for the project of less than four years. The net present value of the project, evaluated over a 10-year analysis period, is about \$1.1 million.

Test burns at SRS have shown that the present stoker boiler fuel handling equipment required no modification to fire the biomass/coal mixture successfully. No fuel-feeding problems were experienced, and no increases in maintenance are expected to be needed at the steam plant. Steam plant personnel have been supportive of the project. Emissions measurements made during initial testing showed level or reduced emissions for all eight measured pollutants, and sulfur emissions are expected to be reduced by 20%. Opacity levels also decreased significantly. The project will result in a reduction of about 2,240 tons per year in coal usage at the facility.

Implementation Barriers

For utility-scale power generation projects, acquiring steady, year-round supplies of large quantities of low-cost biomass can be difficult. But where supplies are available, there are several advantages to using biomass for cofiring operations at federal facilities. For example, federal coal-fired boilers are typically much smaller than utility-scale boilers, and they are most often used for space heating and process heat applications. Thus, they do not have utility-scale fuel requirements.

In addition, federal boilers needed for space heating typically operate primarily during winter months. During summer months, waste wood is often sent to the mulch

market, which makes the wood unavailable for use as fuel. Thus, federal coal-fired boilers could become an attractive winter market for local wood processors. This has been one of the driving factors behind a cofiring demonstration at the Iron City Brewery in Pittsburgh, Pennsylvania.

These are some of the major policy and economic issues and barriers associated with implementing biomass cofiring projects at federal sites:

- *Permit modifications may be required.* Permit requirements vary from site to site, but modifications to existing emissions permits, even for limited-term demonstration projects, may be required for cofiring projects.

- *Economics is the driving factor.* Project economics largely determine whether a cofiring project will be implemented. Selecting sites where waste wood supplies have already been identified will reduce overall costs. Larger facilities with high capacity factors—those that operate at high loads year-round—can utilize more biomass and will realize greater annual cost savings, assuming that wood supplies are obtained at a discount in comparison to coal. This will also reduce payback periods.

Conclusion

DOE FEMP, with the support of staff at the DOE National Laboratories and Regional Offices, offers many services and resources to help federal agencies implement

energy efficiency and renewable energy projects. Projects can be funded through Energy Savings Performance Contracts (ESPCs), Utility Energy Services Contracts, or appropriations. Among these resources is a Technology-Specific “Super ESPC” for Biomass and Alternative Methane Fuels (BAMF), which facilitates the use of biomass and alternative methane fuels to reduce federal energy consumption, energy costs, or both.

Through the BAMF Super ESPC, FEMP enables federal facilities to obtain the energy- and cost-savings benefits of biomass and alternative methane fuels at no up-front cost to the facility. More information about FEMP and BAMF Super ESPC contacts and contract awardees is provided in this *Federal Technology Alert*.

Disclaimer

This report was sponsored by the United States Department of Energy, Energy Efficiency and Renewable Energy, Federal Energy Management Program. Neither the United States Government nor any agency or contractor thereof, nor any of their employees, makes any warranty, express or implied, or assumes any legal liability or responsibility for the accuracy, completeness, or usefulness of any information, apparatus, product, or process disclosed, or represents that its use would not infringe privately owned rights. Reference herein to any specific commercial product, process, or service by trade name, trademark, manufacturer, or otherwise does not necessarily constitute or imply its endorsement, recommendation, or favoring by the United States Government or any agency or contractor thereof. The views and opinions of authors expressed herein do not necessarily state or reflect those of the United States Government or any agency or contractor thereof.

Contents

Abstract	2
About the Technology	3
Application Domain	
Cost-Saving Mechanisms	
Other Benefits	
Installation Requirements	
Federal-Sector Potential	9
Estimated Savings and Market Potential	
Laboratory Perspective	
Application	11
Application Prerequisites	
Cost-Effectiveness Factors	
Where to Apply	
What to Avoid	
Equipment Integration	
Maintenance	
Equipment Warranties	
Codes and Standards	
Costs	
Utility Incentives	
Project Financing and Technical Assistance	
Technology Performance.....	17
Field Experience	
Fuel Supply and Cost Savings Calculations.....	17
Case Study — Savannah River Cofiring Project	18
Facility Description	
Existing Technology Description	
New Technology Description	
Energy Savings	
Life-Cycle Cost	
Performance Test Results	
The Technology in Perspective	20
Manufacturers.....	21
Biomass Pelletizing Equipment	
Boiler Equipment/Cofiring Systems	
Biomass and Alternative Methane Fuels (BAMF) Super ESPC	
Competitively Awarded Contractors	
For Further Information	21
Bibliography	21
Appendix A: Assumptions and Explanations for Screening Analysis	23
Appendix B: Blank Worksheets for Preliminary Evaluation of a Cofiring Project	24
Appendix C: Completed Worksheets for Cofiring Operation at Savannah River Site	28
Appendix D: Federal Life-Cycle Costing Procedures and BLCC Software Information	31
Appendix E: Savannah River Site Biomass Cofiring Case Study: NIST BLCC Comparative Economic Analysis	33

Abstract

Biomass energy technologies convert renewable biomass fuels to heat or electricity. Next to hydro-power, more electricity is generated from biomass than from any other renewable energy resource in the United States. Biomass cofiring is attracting interest because it is the most economical near-term option for introducing new biomass resources into today's energy mix.



Figure 1. The NIOSH boiler plant was modified to cofire biomass with coal.

Cofiring is the simultaneous combustion of different fuels in the same boiler. Cofiring inexpensive biomass with fossil fuels in existing boilers provides an opportu-

nity for federal energy managers to use a greenhouse-gas-neutral renewable fuel while reducing energy and waste disposal costs and enhancing national energy security. Specific requirements will depend on the site. But in general, cofiring biomass in an existing coal-fired boiler involves modifying or adding to the fuel handling, storage, and feed systems. Fuel sources and the type of boiler at the site will dictate fuel processing requirements.

Biomass cofiring can be economical at federal facilities where most or all of these criteria are met: current use of a coal-fired boiler, access to a steady supply of competitively priced biomass, high coal prices, and favorable regulatory and market conditions for renewable energy use and waste reduction. Boilers at several federal facilities were originally designed for cofiring biomass with coal. Others were modified after installation to allow cofiring. Some demonstrations—e.g., at the National Institute of Occupational Safety and Health (NIOSH) Bruce-ton Boiler plant in Pittsburgh, Pennsylvania (Figure 1)—show that, under certain circumstances, only a few boiler plant modifications are needed for cofiring.

This *Federal Technology Alert* was produced as part of the New Technology Demonstration activities in the Department of Energy's Federal Energy Management Program, which is part of the DOE Office of Energy Efficiency and Renewable Energy, to provide facility and energy managers with the information they need to decide whether to pursue biomass cofiring at their facilities.

This publication describes biomass cofiring, cost-saving mechanisms, and factors that influence its performance. Worksheets allow the reader to perform preliminary calculations to determine whether a facility is suitable for biomass cofiring, and how much it would save annually. The worksheets also allow required biomass supplies to be estimated, so managers can work with biomass fuel brokers and evaluate their equipment needs. Also included is a case study describing the design, operation, and performance of a biomass cofiring project at the DOE Savannah River Site in Aiken, South Carolina. A list of contacts and a bibliography are also included.

About the Technology

Biomass is organic material from living things, including plant matter such as trees, grasses, and agricultural crops. These materials, grown using energy from sunlight, can be good sources of renewable energy and fuels for federal facilities.

Wood is the most commonly used biomass fuel for heat and power. The most economical sources of wood fuels are wood residues from manufacturers and mill residues, such as sawdust and shavings; discarded wood products, such as crates and pallets; woody yard trimmings; right-of-way trimmings diverted from landfills; and clean, nonhazardous wood debris resulting from construction and demolition work. Using these materials as sources of energy recovers their energy value and avoids the need to dispose of them in landfills, as well as other disposal methods.

Biomass energy technologies convert renewable biomass fuels to heat or electricity using equipment similar to that used for fossil fuels such as natural gas, oil, or coal. This includes fuel-handling equipment, boilers, steam turbines, and engine generator sets. Biomass can be used in solid form, or it can be converted into liquid or gaseous fuels. Next to hydropower, more electricity is generated from biomass than from any other renewable energy resource in the United States.

Cofiring is a fuel-diversification strategy that has been practiced for decades in the wood products industries and more recently in utility-scale boilers. Several federal facilities have also cofired biomass and coal. Cofiring

involves substituting biomass for a portion of the fossil fuel used in a boiler.

Cofiring inexpensive biomass with fossil fuels in existing federal boilers provides an opportunity for federal energy managers to reduce their energy and waste disposal costs while making use of a renewable fuel that is considered greenhouse-gas-neutral. Cofiring biomass counts toward a federal agency's goals for increasing the use of renewable energy or "green power" (environmentally benign electric power), and it results in a net cost savings to the agency. Cofiring biomass also increases our use of domestic fuels, thus enhancing the nation's energy security.

This publication focuses on the most promising, near-term, proven option for cofiring—using solid biomass to replace a portion of the coal combusted in existing coal-fired boilers. This type of cofiring has been successfully demonstrated in nearly all coal-fired boiler types and configurations, including stokers, fluidized beds, pulverized coal boilers, and cyclones. The most likely opportunities at federal facilities will be found at those that have stokers and pulverized coal boilers. This is because the optimum operating range of cyclone boilers is much larger than that required at a federal facility, and few fluidized bed boilers have been installed at federal facilities for standard, non-research uses.

One of the most important keys to a successful cofiring operation is to appropriately and consistently size the biomass according to the requirements of the type of boiler used. Biomass particles can usually be slightly larger than coal parti-

cles, because biomass is a more volatile fuel. Biomass that does not meet these specifications is likely to cause flow problems in the fuel-handling equipment or incomplete burnout in the boiler. General biomass sizing requirements for each boiler type mentioned here are shown in Table 1.

Table 1. Biomass sizing requirements.

Existing Type of Boiler	Size Required (inches)
Pulverized coal	≤1/4
Stoker	≤3
Cyclone	≤1/2
Fluidized bed	≤3

More detailed information follows about the cofiring options for stoker and pulverized-coal federal boilers.

Stoker boilers. Most coal-fired boilers at federal facilities are stokers, similar to the one shown in the schematic in Figure 2. Because these boilers are designed to fire fairly large fuel particles on traveling or vibrating grates, they are the most suitable federal boiler type for cofiring at significant biomass input levels. In these boilers, fuel is either fed onto the grate from below, as in under-feed stokers, or it is spread evenly across the grate from fuel spreaders above the grate, as in spreader stokers. In the more common spreader-fired traveling grate stoker boiler, solid fuel is mechanically or pneumatically spread from the front of the boiler onto the rear of the traveling grate. Smaller particles burn in suspension above the grate, while the larger particles burn on the grate as it moves the fuel from the back to the front of the boiler. The ash is discharged from the grate into a hopper at the front of the boiler.

The retrofit requirements for cofiring in a stoker boiler will vary, depending on site-specific issues. If properly sized biomass fuel can be delivered to the facility pre-mixed with coal supplies, on-site capital expenses could be negligible. Some facilities have multiple coal hoppers that discharge onto a common conveyor to feed fuel into the boiler. Using one of the existing coal hoppers and the associated conveying equipment for biomass could minimize new capital expenses for a cofiring project. Both methods have been successfully employed at federal stoker boilers for implementing a biomass cofiring project. If neither of these low-cost options is feasible, new handling and storage equipment will need to be added. The cost of these additions is discussed later.

Pulverized coal boilers. There are two primary methods for cofiring biomass in a pulverized coal boiler. The first method, illustrated in Figure 3, involves blending the biomass with the coal before the fuel mix enters the existing pulverizers. This is the least expensive method, but it is limited in the amount of biomass that can be fired. With this blended feed method, only about 3% or less of the boiler's heat input can be obtained from biomass at full boiler loads because of limitations in the capacity of the pulverizer.

The second method, illustrated in Figure 4 on page 5, requires installing a separate processing, handling, and storage system for biomass, and injecting the biomass into the boiler through dedicated biomass ports. Although this method is more expensive, it allows greater amounts of biomass to be used—up to 15% more on a

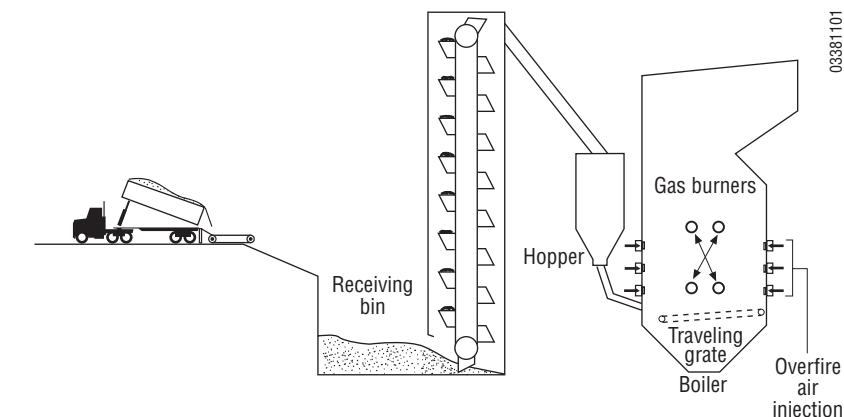

Figure 2. Schematic of a typical traveling-grate spreader-stoker.

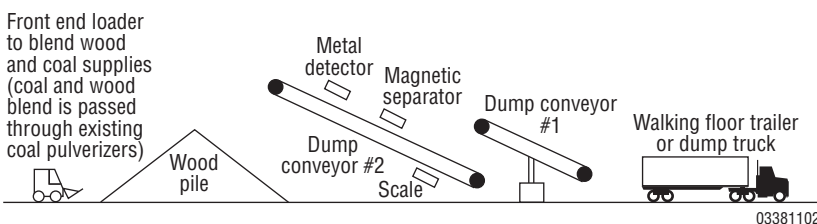

Figure 3. Schematic of a blended-feed cofiring arrangement for a pulverized coal boiler.

heat input basis. If the biomass is obtained at a significant discount to current coal supplies, the additional expense may be warranted to offset coal purchases to a greater degree.

Application Domain

The best opportunities for cofiring biomass with fossil fuels at federal facilities are at sites with regularly operating coal-fired boilers. Biomass cofiring has been successfully demonstrated in nearly all coal-fired boiler types and configurations, including stokers, fluidized beds, pulverized coal boilers, and cyclones. The least expensive opportunities are most likely to be for stoker boilers, but cofiring in pulverized coal boilers may also be economically attractive.

At least 10 facilities in the federal sector have had experience with biomass cofiring. Two facilities—

the NIOSH Bruceton boiler plant in Pennsylvania and DOE's Savannah River Site in South Carolina—have been considering implementing commercial cofiring applications. Other federal sites with cofiring experience include KI Sawyer Air Force Base in Michigan, Fort Stewart in Georgia, Puget Sound Naval Shipyard in Washington, Wright-Patterson Air Force Base in Ohio, Brunswick Naval Air Station in Maine, and the Red River Army Depot in Texas.

More than 100 U.S. companies or organizations have experience in cofiring biomass with fossil fuels, and many cofiring boilers are in operation today. Most are found in industrial applications, in which the owner generates a significant amount of biomass residue material (such as sawdust, scrap wood, bark, waste paper, or cardboard or agricultural residues

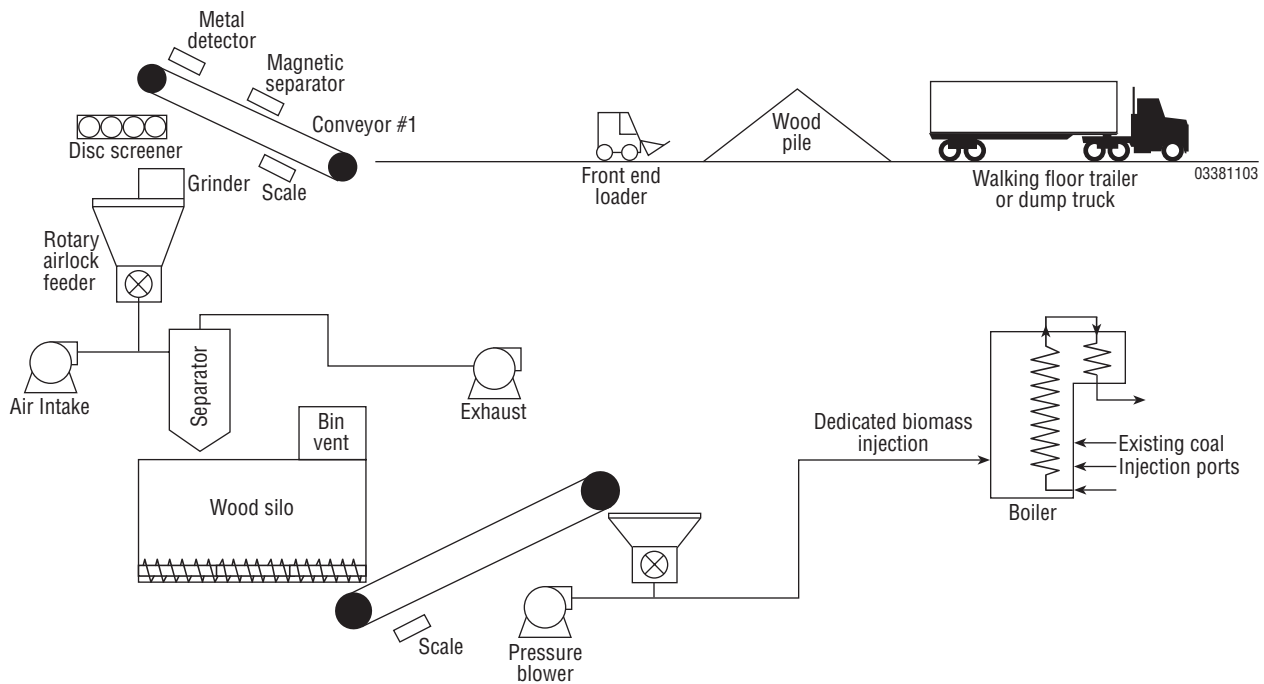

Figure 4. Schematic of a separate-feed cofiring arrangement for a pulverized coal boiler.

like orchard trimmings and coffee grounds) during manufacturing. Using these residues as fuel allows organizations to avoid landfill and other disposal costs and offsets some purchases of fossil fuel. Most ongoing cofiring operations are in stoker boilers in one of four industries: wood products, agriculture, textiles, and chemicals.

A screening analysis was done to determine which states have the most favorable conditions for a financially successful cofiring project. The primary factors considered were average delivered state coal prices, estimated low-cost biomass residue supply density (heat content in Btu of estimated available low-cost biomass residues per year per square mile of state land area), and average state landfill tipping fees. See Appendix A for a more detailed discussion.

The top 10 states in the analysis were classified as having high potential for a biomass cofiring

project, and the next 10 states were classified as having good potential. See Table 2 and Figures 5 and 6.

Table 2. States with most attractive conditions for biomass cofiring.

Cofiring Potential	State
High Potential	Connecticut
	Delaware
	Florida
	Maryland
	Massachusetts
	New Hampshire
	New Jersey
	New York
	Pennsylvania
	Washington
Good Potential	Alabama
	Georgia
	Indiana
	Michigan
	Minnesota
	North Carolina
	Ohio
	South Carolina
	Tennessee
	Virginia

Within each group in Table 2, states are shown in alphabetical order, because slight variations in rankings result from selecting weighting-factor values. The analysis was intended simply to indicate which states have the most helpful conditions for economically successful cofiring projects. It found that the Northeast, Southeast, Great Lakes states, and Washington State are the most attractive locations for cofiring projects.

Utility-scale cofiring projects are shown on the map in Figure 5. These sites are in or near states identified by the screening model as having good or high potential for cofiring. This increases confidence that the states selected by the screening process were reasonable choices. Figure 6 shows the locations of existing federal coal-fired boilers. There is good correspondence between the locations of these facilities and the states identified as promising for cofiring.

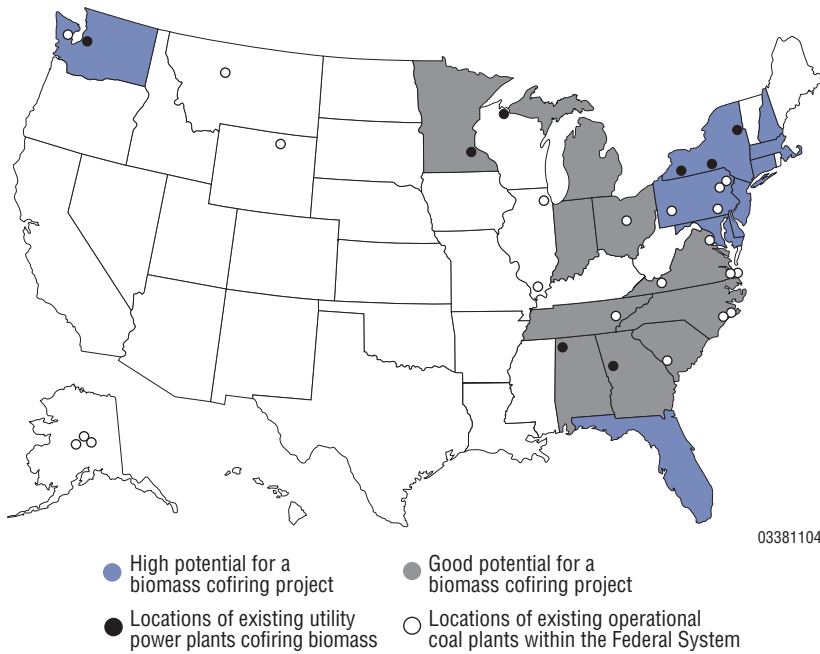

Figure 5. States with most favorable conditions for biomass cofiring, based on high coal prices, availability of biomass residues, and high landfill tipping fees.

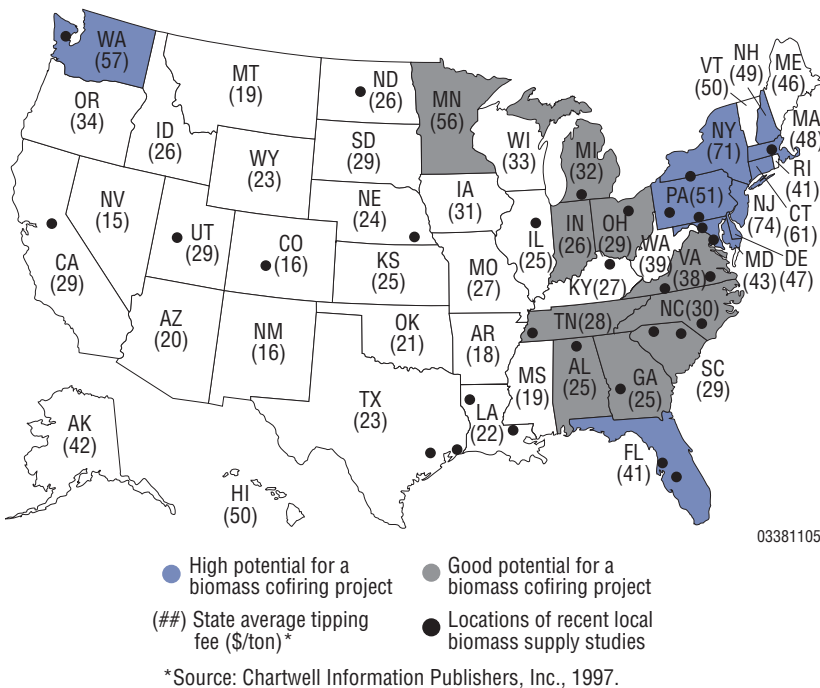

Figure 6. Average tipping fee and locations of local biomass supply studies (Chartwell 1997, Wiltsee 1998).

Coal-fired federal boilers in the 20 states indicated in the study would be promising for cofiring

biomass if annual coal use is high enough to obtain significant annual cost savings—enough to

pay off the initial investment—by switching part of the fuel supply to biomass. Federal facilities that operate coal-fired boilers but are not in states on the list in Table 2 could still be good candidates for cofiring if specific conditions at their sites are favorable.

“Wild card” factors, such as the impact of a motivated project manager or biomass resource supplier, the local availability of biomass, and the fact that a large federal facility or campus could act as its own source of biomass fuel, capitalizing on fuel cost reductions while avoiding landfill fees. These factors could easily tip the scales in favor of a particular site. The coal-fired boilers in Alaska could be examples of good candidates not located in highly rated states because of a long heating season, large size, and very high coal prices.

The map in Figure 6 indicates average landfill tipping fees for each state. It also shows cities in which fairly recent local biomass resource supply and cost studies have been performed, as reported in *Urban Wood Waste Resource Assessment* (Wiltsee 1998). Additional information on potential biomass resource supplies near federal facilities can be obtained from the DOE program manager for the Technology-Specific Super ESPC for Biomass and Alternative Methane Fuels, or BAMF; contact information can be found later in this publication. To encourage new projects under the BAMF Super ESPC, the National Energy Technology Laboratory (NETL) has compiled a database that identifies federal facilities within 50 miles of 10 or more potential sources of wood waste.

Cost-Saving Mechanisms

Cofiring operations are not implemented to save energy—they are implemented to reduce energy costs as well as the cost of other facility operations. In a typical cofiring operation, the boiler requires about the same heat input as it does when operating in a fossil-fuel-only mode. When cofiring, the boiler operates to meet the same steam loads for heating or power-generation operations as it would in fossil-fuel-only mode; usually, no changes in boiler efficiency result from cofiring unless a very wet biomass is used. With no change in boiler loads, and no change in efficiency, boiler energy usage will be the same. The primary savings from cofiring are cost reductions resulting from (1) replacing a fraction of high-cost fossil fuel purchases with lower cost biomass fuel, and (2) avoiding landfill tipping fees or other costs that would otherwise be required to dispose of the biomass.

According to data obtained from the Defense Energy Support Center (DESC), the average delivered cost of coal for 18 coal-fired boilers operated by the Department of Defense (DoD) was about \$49 per ton in 1999, or about \$2.10 per million Btu. (The average coal heating value for those boilers is about 11,500 Btu/lb) Coal costs for those facilities ranged from \$1.60 to \$3 per million Btu, depending on the location, coal type, and annual quantity consumed. The average annual coal cost for these boilers was about \$2 million and ranged from \$28,000 to \$8.9 million per year. According to three independently conducted studies that esti-

mated the quantities and costs of unused and discarded wood residues in the United States, large quantities of biomass are available at delivered costs well below the \$2.10 per million Btu average price of coal at the DoD facilities. Coal prices at other federal facilities are likely to be similar.

For example, if 15% of the coal used at a boiler were replaced by biomass delivered to the plant for \$1.25 per million Btu, annual fuel cost savings for the average DoD boiler described above would be more than \$120,000. Neither the cofiring rate of 15% of the boiler's total heat input, nor the delivered price of \$1.25 per million Btu, is unrealistic, especially for stoker boilers. Higher cofiring rates and lower biomass prices are common in current cofiring projects. Note that the cost of most biomass residues will range from \$2 to \$3 per million Btu, so successful cofiring project operators must try to obtain the biomass fuel at a low price.

The average landfill tipping fee in the United States is about \$36 per ton of material dumped. Average tipping fees for each state are shown in Figure 6. If significant quantities of clean biomass residues—such as paper, cardboard, or wood—are generated at a federal site, and if some of that material can be diverted from landfill disposal and used as fuel in a boiler, the savings generated would be equivalent to about \$66 per ton of biomass: \$36/ton by avoiding the tipping fee, and \$30/ton by replacing the coal with biomass. Since biomass has a lower heating value than coal, it takes more than one ton of biomass to offset the heat provided by one ton of coal. A ton of fairly

dry biomass would have a heating value of about 7,000 Btu/lb, compared with an average of 11,500 Btu/lb for the coal used at DoD facilities. Each ton of biomass will thus offset $7,000/11,500 = 0.61$ ton of coal. If the biomass is used to replace coal at \$49/ton, each ton of biomass is worth $\$49/\text{ton} \times 0.61 = \30 in fuel cost savings. The typical cost of processing biomass waste material into a form suitable for use in a boiler is \$10 per ton, so the net costs savings per ton of biomass residues could be about \$56: \$66/ton for the fuel and landfill cost savings minus \$10/ton for the biomass processing cost. This assumes that the biomass is available at no additional transportation costs, as is the case at the Savannah River Site.

If the average DoD facility using a coal-fired boiler could obtain biomass fuel by diverting its own residues from landfill disposal, the net annual cost savings would be about \$560,000 per year. This would require about 10,000 tons of biomass residues per year, a quantity higher than most federal facilities generate internally. The savings generated by a real cofiring project would be expected to fall somewhere between the two examples given here—between \$120,000 and \$560,000 per year. They would probably depend on using some biomass materials generated on site and some supplied by a third party.

Other Benefits

When used as a supplemental fuel in an existing coal boiler, biomass can provide the following benefits, with modest capital outlays for plant modifications:

- *Reduced fuel costs.* Savings in overall production costs can be achieved if inexpensive biomass fuel sources are available (e.g., clean wood waste). Biomass fuel supplies at prices 20% or more below current coal prices will usually provide the cost savings needed.
- *Reduced sulfur oxide and nitrogen oxide emissions.* Because of differences in the chemical composition of biomass and coal, emissions of acid rain precursor gases—sulfur oxides (SO_x) and nitrogen oxides (NO_x)—can be reduced by replacing coal with biomass. Because most biomass has nearly zero sulfur content, SO_x emissions reductions occur on a one-to-one basis with the amount of coal (heat input) offset by the biomass. Reducing the coal supply to the boiler by 10% will reduce SO_x emissions by 10%. Mechanisms that lead to NO_x savings are more complicated, and relative savings are typically less dramatic than the SO_x reductions are, on a percentage basis.
- *Landfill cost reductions.* Using waste wood as a fuel diverts the material from landfills and avoids landfill disposal costs.
- *Reduced greenhouse-gas emissions.* Sustainably grown biomass is considered a greenhouse-gas-neutral fuel, since it results in no net carbon dioxide (CO₂) in the atmosphere. Using biomass to replace 10% of the coal in an existing boiler will reduce the net greenhouse-gas emissions by approximately 10% if the biomass resource is grown sustainably.
- *Renewable energy when needed.* Unlike other renewable energy technologies like those based on solar and wind resources, biomass-based systems are available whenever they are needed. This helps to accelerate the capital investment payoff rate by producing more heat or power per unit of installed capacity.
- *Market-ready renewable energy option.* Cofiring offers a fast-track, low-cost opportunity to add renewable energy capacity economically at federal facilities.
- *Fuel diversification.* The ability to operate using an additional fuel source provides a hedge against price increases and supply shortages for existing fuels such as stoker coals. In a cofiring operation, biomass can be viewed as an opportunity fuel, used only when the price is favorable. Note that administrative costs could increase because of the need to purchase multiple fuel supplies; this should be considered when evaluating this benefit.
- *Locally based fuel supply.* The most cost-effective biomass fuels are usually supplied from surrounding areas, so economic and environmental benefits will accrue to local communities.

Installation Requirements

Specific requirements depend on the site that uses biomass in cofiring. In general, however, cofiring biomass in an existing coal boiler requires modifications or additions to fuel-handling, processing, storage, and feed systems. Slight

modifications to existing operational procedures, such as increasing over-fire air, may also be necessary. Increased fuel feeder rates are also needed to compensate for the lower density and heating value of biomass. This does not usually present a problem at federal facilities, where boilers typically operate below their rated output. When full rated output is needed, the boiler can be operated in a coal-only mode to avoid derating.

Expected fuel sources and boiler type dictate fuel processing requirements. For suspension firing in pulverized coal boilers, biomass should be reduced to a particle size of 0.25 in. or smaller, with moisture levels less than 25% when firing in the range of 5% to 15% biomass on a heat input basis. Equipment such as hoppers, hammer mills, spike rolls, and disc screens may be required to properly size the feedstock. Local wood processors are likely to own equipment that can adequately perform this sizing in return for a processing fee. Other boiler types (cyclones, stokers, and fluidized beds) are better suited to handle larger fuel particles.

Two common forms of processed biomass are shown in Figure 7, along with a typical stoker coal, shown in the center of the photo. Recent research and demonstration on several industrial stoker boilers in the Pittsburgh area has shown that wood chips (on the right) are preferable to mulch-like material (on the left) for cofiring with coal in stoker boilers that have not been designed or previously reconfigured for multifuel firing. The chips are similar to stoker coal in terms of size and flow characteristics;

therefore, they cause minimal problems with existing coal-handling systems. Using a mulch-like material, or a biomass supply with a high fraction of fine particles (sawdust size or smaller) can cause periodic blockage of fuel flow openings in various areas of the conveying, storage, and feed systems. These blockages can cause significant maintenance increases and operational problems, so fuel should be processed to avoid those difficulties. With properly sized and processed biomass fuel, cofiring operations have been implemented successfully without extensive modifications to equipment or operating procedures at the boiler plant.

Federal-Sector Potential

A large percentage of federal facilities with coal-fired boilers have the potential to benefit from this technology. However, as noted, the potential is highest in areas with high coal prices, easy-to-obtain biomass resources, and high landfill tipping fees.



Figure 7. Comparison of two biomass residues with coal. Because they are similar in size and flow characteristics, wood chips (right) flow more like coal (center) in stoker boilers. Wood chips can thus be used in existing boilers with minimal modifications to fuel-handling systems. Mulch-like processed wood (left) is more problematic.

The potential savings resulting from using the technology at typical federal facilities with existing coal-fired boilers were estimated as part of the technology-screening process of FEMP's New Technology Demonstration activities. Payback periods are usually between one and eight years, and annual fuel cost savings range from \$60,000 to \$110,000 for a typical federal boiler. Savings depend on the availability of low-cost biomass feedstocks. The savings would be greater if the federal site can avoid landfill costs by using its own clean biomass waste materials as part of the biomass fuel supply.

Estimated Savings and Market Potential

The National Renewable Energy Laboratory (NREL) conducted a study for FEMP of the economic and environmental impacts of biomass cofiring in existing federal boilers, as well as associated savings. Results of the study are presented in Tables 3 through 6 on pages 10 and 11. As shown in

Table 6, cofiring biomass with coal at one typical coal-fired federal facility will replace almost 3,000 tons of coal per year, could divert up to about 5,000 tons of biomass from landfills, and will reduce net carbon dioxide (CO₂) emissions by more than 8,000 tons per year and sulfur dioxide (SO₂) emissions by about 136 tons per year. Reductions in NO_x emissions could also

occur. In terms of CO₂ reductions, this would be equivalent to removing about 1,000 average-sized automobiles from U.S. highways.

Additional indirect benefits could also occur. If the biomass fuel would otherwise be sent to a landfill to decay over a period of time, methane (CH₄) would be released to the atmosphere as a by-product of the decomposition process, assuming no landfill-gas-capturing system is installed. Since CH₄ is 21 times more powerful than CO₂ in terms of its ability to trap heat in the atmosphere and increase the greenhouse effect, cofiring at one typical coal-fired federal facility could avoid decomposition processes that would be equivalent to reducing an additional 29,000 tons of CO₂ emissions per year.

Payback periods using cofiring at suitable federal facilities are between one and eight years. Annual cost savings range from about \$60,000 to \$110,000 for a typical federal boiler, if low-cost biomass feedstocks are available. There are more than 1500 industrial-scale stoker boilers in operation in the United States. If federal technology transfer efforts result in cofiring projects at 50 boilers (this is about 7% of existing U.S. stokers), the resulting CO₂ reductions would be about 405,000 tons/yr (the equivalent of removing about 50,000 average-size cars from U.S. highways), and SO₂ reductions would be about 6,700 tons/yr. If all biomass materials used in these boilers were diverted from landfills with no gas capture, the greenhouse-gas equivalent of an additional 1.45 million tons of CO₂ emissions would be avoided.

(Continued on page 11)

Table 3. Example economics of biomass cofiring in power generation applications (vs. 100 percent coal).

Boiler Type	Example Plant Size (MW)	Heat from Biomass (%)	Biomass Power (MW)	Unit Cost (\$/kW) ¹	Total Cost for Cofiring Retrofit (\$)	Net Annual Cost Savings (\$/yr) ²	Payback Period (years)	Production Cost, no Cofiring (¢/kWh) ³	Production Cost, with Cofiring (¢/kWh) ³
Stoker (low cost)	15	20	3.0	50	150,000	199,760	0.8	5.25	5.03
Stoker (high cost)	15	20	3.0	350	1,050,000	199,760	5.3	5.25	5.03
Fluidized bed	15	15	2.3	50	112,500	149,468	0.8	5.41	5.24
Pulverized coal	100	3	3.0	100	300,000	140,184	2.1	3.26	3.24
Pulverized coal	100	15	15.0	230	3,450,000	700,922	4.9	3.26	3.15

Notes:

¹Unit costs are on a per kW of biomass power basis (not per kW of total power).

²Net annual cost savings = fuel cost savings – increased O&M costs.

³Based on data obtained from EPRI's *Technical Assessment Guide*, 1993, EIA's *Costs of Producing Electricity*, 1992, UDI's *Electric Power Database*, EPRI/DOE's *Renewable Energy Technology Characterizations*, 1997, coal cost of \$2.10/MBtu, biomass cost of \$1.25/MBtu, and capacity factor of 70%.

Table 4. Example environmental impacts of cofiring in power generation applications (vs. 100 percent coal).

Boiler Type	Example Plant Size (MW)	Heat from Biomass	Reduced Coal Use (tons/yr)	Biomass Used (tons/yr) ¹	Annual CO ₂ Savings (tons/yr) ²	Annual SO ₂ Savings (tons/yr)	Annual NO _x Period (tons/yr)
Stoker (low cost)	15	20%	10,125	16,453	27,843	466	N/A
Stoker (high cost)	15	20%	10,125	16,453	27,843	466	N/A
Fluidized bed	15	15%	7,578	12,314	20,839	349	N/A
Pulverized coal	100	3%	7,429	12,072	20,430	342	N/A
Pulverized coal	100	15%	37,146	60,362	102,151	1,709	N/A

Notes:

¹Depending on the source of biomass, "biomass used" could be avoided landfilled material.

²Carbon savings can easily be calculated from CO₂ savings (i.e., carbon savings = 12/44 x CO₂ savings).

Table 5. Example economic of biomass cofiring in heating applications (vs. 100 percent coal).

Example Boiler Size (steam lb/hr)	No. of Boilers at Site	Heat from Biomass (steam lb/hr)	Biomass Capacity (steam lb/hr)	Unit Cost (\$/lb/hr) ¹	Total Cost for Cofiring Retrofit (\$)	Net Annual Cost Savings (\$/yr) ²	Payback Period (years)
120,000	2	15%	36,000	2.8	100,075	41,628	2.4

Notes:

¹Unit costs are on a per unit of biomass capacity basis (not per unit of total capacity).

²Assumptions: coal cost of \$2.10/MBtu and capacity factor of 25% (based on data from coal-fired federal boilers), biomass cost of \$1.25/MBtu.

Table 6. Potential environmental impact of cofiring in heating applications (vs. 100 percent coal).

No. of Cofiring Projects ^{1,2}	Reduced Coal Use (tons/yr)	Biomass Used (tons/yr) ³	Annual CO ₂ Savings (tons/yr) ⁴	Annual SO ₂ Savings (tons/yr)	Annual NO _x Period (tons/yr)
1	2,947	5,057	8,103	136	N/A
2	5,893	10,114	16,206	271	N/A
10	29,466	50,570	81,030	1,355	N/A
50	147,328	252,851	405,151	6,777	N/A

Notes:

¹There are approximately 1500 industrial stoker boilers operating today.

²Assumptions for the average project were: 120,000 lb/hr steam capacity per boiler, 2 boilers at site, 15% heat from biomass, and a 25% capacity factor.

³Depending on the source of biomass, "biomass used" could be avoided landfilled material.

⁴Carbon savings can easily be calculated from CO₂ savings (i.e., carbon savings = 12 / 44 x CO₂ savings).

Laboratory Perspective

Since the 1970s, DOE and NETL have worked with alternative fuels such as solid waste and refuse-derived fuel. In 1995, NETL, Sandia National Laboratories, and NREL sponsored a workshop that led to several projects evaluating technical and commercial issues associated with biomass cofiring. These projects included research conducted or sponsored by NETL, NREL, Sandia, and Oak Ridge National Laboratory (ORNL) on char burnout; ash deposition; NO_x behavior; cofiring demonstration projects using various boiler types, coal/biomass feedstock combinations, and fuel handling systems; reburning for enhanced NO_x reduction; and the use of ash. These efforts have led to improved and documented knowledge about the impacts of cofiring biomass with coal in a wide range of circumstances.

Results from a joint Sandia/NETL/NREL project found that in terms of slagging and fouling, wood was more benign than herbaceous crops. It has also been shown

that, in general, NO_x emissions decrease with cofiring as a result of the lower nitrogen content of most woody biomass in relation to coal, and the greater volatility of biomass in relation to coal. The greater volatility of biomass results in a natural staging of the combustion process that can reduce NO_x emissions to levels below those expected on the basis of fuel nitrogen contents.

DOE, NETL, and the Electric Power Research Institute (EPRI) also collaborated on short-term demonstration projects. Several of the demonstrations took place at federal facilities in the Pittsburgh area. They found no significant impact on boiler efficiency at low levels of cofiring. Fuel procurement, handling, and preparation were found to require special attention.

In addition, DOE's Idaho National Energy and Environmental Laboratory (INEEL) and DOE's Savannah River Site have biomass-cubing equipment that can convert paper and wood waste materials into a form that can

be used more easily as fuel at existing coal-fired facilities. In a separate project with funding from NETL, the University of Missouri-Columbia's Capsule Pipeline Research Center examined the potential for compacting various forms of biomass into small briquettes or cubes for use as supplemental fuels at existing coal-fired boilers. The results indicated that biomass fuel cubes could be manufactured and delivered to a power plant for as little as \$0.30 per million Btu, or less than \$5 per ton. This price included all capital and operating costs for the manufacturing facility plus transportation costs within a 50-mile radius. The analysis assumed the facility would collect a \$15-per-ton tipping fee for biomass delivered to the site. See the bibliography for more detailed information on biomass cofiring research activities and published results of research led by DOE and its laboratories.

Application

This section addresses technical aspects of biomass cofiring in

coal-fired boilers, including the range of situations in which cofiring technology can be used best. First, prerequisites for a successful biomass cofiring application are discussed, as well as the factors that influence the cost-effectiveness of projects. Design and integration considerations are also discussed and include equipment and installation costs, installation details, maintenance, and permitting issues.

Application Prerequisites

The best opportunities for cofiring occur at sites in which many of the following criteria apply:

- *Existing, operational coal-fired boiler.* It is possible to cofire biomass with fossil fuels other than coal; however, the similarities in the fuel-handling systems required for both coal and biomass (because they are both solid fuels) usually make cofiring less expensive at coal-fired facilities. An exception could be cofiring applications in which the biomass fuel is gas piped to the boiler from a nearby landfill. Cofiring with landfill gas has been done in both coal-fired and natural-gas-fueled boilers, but is less common than solid-fuel cofiring because of the need for a large boiler very close to the landfill.
- *Local expertise for collecting and processing biomass.* Most boiler operators at federal facilities are not likely to be interested in purchasing and operating equipment to process biomass into a form that can be used as boiler fuel. Thus, it is advantageous for the facility to have

access to local expertise in collecting and processing waste wood. This expertise can be found primarily among companies specializing in materials recycling, mulch, and wood products.

- *Boiler plant equipped with a baghouse.* Cofiring biomass with coal has been shown to increase particulate emissions in some applications in comparison to coal-only operation. If the existing facility is already equipped with a baghouse or cyclone separation devices, this should not be a significant problem; in other words, it should not cause noncompliance with particulate emissions standards. The existing baghouse or cyclone typically provides sufficient particulate filtration to allow stack gases to remain in compliance with air permits. However, some small coal-fired boilers are not equipped with these devices. Instead, they use methods such as natural gas overfiring to reduce particulate emissions. In such cases, a new baghouse may be required to permit cofiring biomass at significant input levels, and this would increase project costs significantly.
- *Storage space available on site.* Unless the biomass is immediately fed into a boiler's fuel-handling system upon delivery, a temporary staging area at the boiler plant will be needed to store processed biomass supplies. An ideal storage facility would have at least a concrete pad and a roof to minimize the accumulation of moisture and dirt. It may also be possible to arrange storage through the biomass fuel provider.
- *Receptive plant operators at the federal facility.* At the very least, increases will be necessary in administrative activities associated with adding a new fuel to a boiler plant's fuel mix. In addition, new or additional boiler control and maintenance procedures will be required to use biomass effectively. As opposed to a capital improvement project, which requires one-time installation and minimal attention afterwards (such as equipment upgrades), a cofiring operation requires ongoing changes in fuel procurement, fuel-handling, and boiler control operations. Receptive boiler plant operators and management are therefore instrumental in implementing and sustaining a successful cofiring project.
- *Favorable regulatory climate for renewable energy.* As of February 2003, 28 states had either enacted electricity restructuring legislation or issued orders to open their electricity markets to competition. Most of these states have established some type of incentive program to encourage more installations of renewable energy technologies. Since biomass is a renewable energy resource, some states may provide favorable conditions for implementing a cofiring project through incentive programs, technical assistance, or flexible permitting procedures.

Cost-Effectiveness Factors

The list below presents the major factors influencing the cost-effectiveness of biomass cofiring applications. The worksheets in Appendix B provide procedures for estimating total project cost savings based on easy-to-obtain information for any federal facility with a coal-fired boiler.

- **Coal supply price.** The higher the coal supply price, the greater the potential cost savings from implementing a biomass cofiring project. Prices above \$1.30 per million Btu are usually high enough to make cofiring worth considering, especially if some of the other factors mentioned in this section are also favorable. Since the average delivered coal price for boilers operated by DoD was about \$2.10 per million Btu in 1999, and ranged from \$1.60 to \$3.00 per million Btu, coal prices at nearly all federal facilities should be high enough to make biomass cofiring worth considering.
- **Biomass supply price.** Abundant local supplies of low-cost biomass are necessary for cost-effective biomass cofiring projects. This is most likely to occur near cities, wood-based industries, or landfills and material recycling facilities where wood waste is collected. NREL conducted a study that examined national waste wood availability and costs based on detailed local data gathered from 30 cities throughout the United States. The study indicates that more than 60 million tons of wood waste per year could be available at a low enough cost to make cofiring economically

viable at nearly any federal facility. This amount of wood contains 40 times the amount of energy supplied by coal to all DoD-operated federal facilities in 1999.

- **Landfill tipping fees.** High local landfill tipping fees increase the probability that low-cost biomass supplies could be available for a cofiring project. Average state landfill tipping fees are indicated in Figure 6. The average U.S. tipping fee is about \$36 per ton, and the fee ranges from about \$15 per ton in Nevada to about \$74 per ton in New Jersey.
- **Boiler size and usage patterns.** Boiler size and capacity factor were considered in the initial screening process (see Figure 5). Larger, high-capacity-factor facilities (those that operate at high loads year-round) can use more biomass and will realize greater annual cost savings. This in turn reduces project payback periods. Because the amount of environmental paperwork needed is significantly less if less than 5,000 tons of coal are burned annually, smaller facilities might also want to consider cofiring.
- **Boiler modifications and equipment additions required.** Start-up costs are a key consideration in evaluating any cofiring project. The cost of modifying an existing facility to use biomass or to purchase equipment to prepare biomass for cofiring can range from nearly nothing to as much as \$6/lb per hour of boiler steaming capacity.

Where to Apply

The most common applications for biomass cofiring are at coal-fired boilers located in areas with an adequate, reliable supply of biomass fuel. For a list of states in which these conditions are most likely to occur, see Table 2 and Figures 5 and 6.

What to Avoid

Major technical issues and problems associated with implementing a biomass project at a federal site are listed below. Each problem can be addressed with technical assistance from experts with experience in cofiring projects.

- **Slagging, fouling, and corrosion.** Some biomass fuels have high alkali (principally potassium) or chlorine content, or both. This can lead to unmanageable ash deposition problems on heat exchange and ash-handling surfaces. Chlorine in combustion gases, especially at high temperatures, can cause accelerated corrosion of combustion system and flue gas clean-up components. These problems can be minimized or avoided by screening fuel supplies for materials high in chlorine and alkalis, by limiting the biomass contribution to boiler heat input to 15% or less, by using fuel additives, or by increased sootblowing. Additional site-specific adjustments may be necessary. Annual crops and agricultural residues, including grasses and straws, tend to have high alkali and chlorine contents. In contrast, most woody materials and waste papers are low in alkali and chlorine. As a precaution, a sample of each new type of fuel should be tested for

both chlorine and alkali before use. For further details on the alkali deposits associated with biomass fuels, including recommendations for fuel testing methods and specifications, see Miles et al. 1996.

- *Fuel-handling and processing problems.* Certain equipment and processing methods are required to reduce biomass to a form compatible with coal-fired boilers and flue-gas-handling systems. Most coal boiler operators are not familiar with biomass processing, so technical assistance may be needed to help make the transition to biomass cofiring. Some cofiring facilities have found it more convenient and cost-effective to have biomass processed by a third-party fuel supplier; in some cases, this is their coal supplier. When wood is used, chips tend to work much better than mulch-like material. Large quantities of fine, sawdust-like material should also be avoided because they plug up the fuel supply and storage system.
- *Underestimating fuel acquisition efforts.* Securing dependable, clean, economical sources of biomass fuels can be time-consuming, but this is one of the most important tasks in establishing a biomass project. Federal facilities that already have staff with experience in aggregating and processing biomass are ideal sites for projects. In most cases, however, technical assistance will probably be required in this area.
- *Boiler efficiency losses.* Some design and operational changes are needed to maximize boiler efficiency while maintaining acceptable opacity, baghouse performance, and so on. Without these adjustments, boiler efficiency and performance can decrease. For example, boiler efficiency losses of 2% were measured during cofiring tests at a pulverized coal boiler at a heat input level from biomass of 10% (Tillman 2000, p. 373). Numerous cofiring projects have demonstrated that efficiency and performance losses can be minimized with proper attention, however. These losses should be included in the final economic evaluation for a project.
- *Negative impacts on ash markets.* Concrete admixtures represent an important market for some coal combustion ash by-products. Current ASTM standards for concrete admixtures require that the ash be 100% coal ash. Efforts are under way to demonstrate the suitability of commingled biomass and coal ash in concrete admixtures, but in the near term, cofired ash will not meet ASTM specifications. This is a serious problem for some utility-scale power plants that obtain a significant amount of revenue from selling ash. Since most federal facilities dispose of ash rather than sell it, this issue should not be a problem; however, ash disposal methods at each potential project site should be considered early in the evaluation process to avoid future problems.

Equipment Integration

A typical stoker boiler is shown in Figure 8. Recent demonstration projects of stoker boilers in Pittsburgh, Pennsylvania; Idaho Falls, Idaho; and Aiken, South Carolina, have shown that properly sizing the biomass fuel helps to avoid the need for modifications to the existing boiler. The Pittsburgh project used premixed coal and wood chips. As indicated in Figure 8, no modifications were needed to deliver the mixed fuel to the dump grate after the switch from coal-only supplies. However, cofiring biomass in an existing coal boiler usually requires at least slight modifications or additions to fuel-handling, processing, storage, and feed systems. Specific requirements vary from site to site.

Fuel processing requirements are dictated by the fuel source and boiler type. For suspension firing in pulverized coal (PC) boilers, biomass should be reduced to a maximum particle size of 0.25 in. at moisture levels of less than 25%. When firing in the range of 5% to 15% biomass (on a heat input basis), a separate injection system is normally required. For firing small amounts of biomass in a PC boiler (less than 5% of total heat), the biomass can be blended with the coal before injection into the furnace.

Additional processing and handling equipment requirements make separate injection systems more expensive than blended-feed systems, but they offer the advantage of higher biomass firing rates. Cyclone, stoker, and fluidized-bed boilers are better suited to handle larger fuel particles, and they are thus usually less expensive to modify than PC boilers. In general,

each boiler and fuel combination must be carefully evaluated to maximize boiler efficiency, minimize costs, and avoid combustion-related problems in the furnace.

Maintenance

Maintenance requirements for boilers cofiring biomass and coal are similar to those for coal-only boilers. However, slight changes to previous operational procedures, such as increasing over-fire air and fuel feeder speeds, may be needed. For a project to be successful, the biomass fuel must be processed before cofiring to avoid large increases in current maintenance levels.

Equipment Warranties

If additional equipment is required to implement a cofiring project, it is most likely to be commercially available. Therefore, it will carry the standard manufacturer's warranty, which is usually a minimum of one year for parts. Installation labor usually carries a one-year warranty, as well.

Codes and Standards

Permit requirements vary from site to site, but a facility's emissions permits—even for limited-term demonstration projects—usually have to be modified for cofiring projects. Results from earlier cofiring projects in which emissions were not negatively affected can be helpful during the permit modification process. Air permitting officials also may need detailed chemical analyses of biomass fuel supplies and a fuel supply plan to evaluate the permit requirements for a cofiring project. NETL and the University of Pittsburgh are already developing this type of information. Preliminary results can be found in several papers listed in the bibliography.

Because of increases in regulations for particulate emissions and increases in the availability of natural gas, some federal boilers are being converted from coal to natural gas despite the higher cost. Fifteen projects in which natural gas (at about 10% of boiler heat

input) is cofired with coal or wood have been implemented or are in progress. Eleven of these projects involve coal-fired boilers and four involve wood-fired units. They include the coal-fired Capital Heating Plant in Washington, D.C. Such projects do not eliminate the possibility of cofiring biomass with natural gas and coal, however. If biomass can be obtained more cheaply than coal and gas, using biomass could help offset the cost of the gas.

Costs

Cofiring system retrofits require relatively small capital investments per unit of capacity, in comparison to those required for most other renewable energy technologies and carbon sequestration alternatives. Costs as low as \$50 to \$100/kW of biomass power can be achieved for stokers, fluidized beds, and low-percentage (less than 2% biomass on a heat basis) cofiring in cyclone and PC boilers. For heating applications, this is equivalent to about \$3 to \$6/lb per hour of steaming capacity.

Retrofits for high-percentage cofiring (up to 15% of the total heat input) at a pulverized coal (PC) boiler are typically about \$200/kW of biomass power capacity. Smaller applications such as those at federal facilities have higher per-unit costs because they cannot take advantage of economies of scale. For example, a small-scale stoker application that requires a completely new receiving, storage, and handling system for biomass could cost as much as \$350/kW of biomass power capacity.

When inexpensive biomass fuels are used, cofiring retrofits have

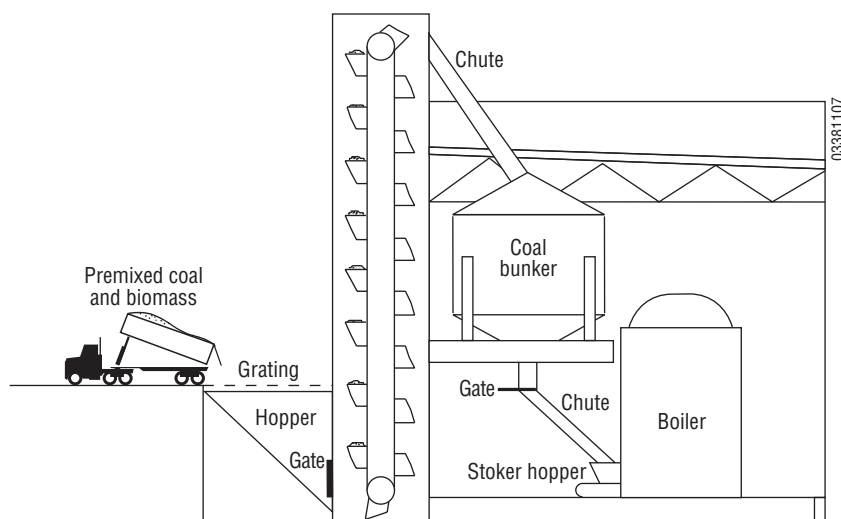

Figure 8. A typical stoker boiler conveyor system receiving premixed coal and biomass (Adapted from J. Cobb et al., June 1999).

payback periods ranging from one to eight years. A typical existing coal-fired power plant can produce power for about 2.3¢/kWh. However, cofiring inexpensive biomass fuels can reduce this cost to 2.1¢/kWh. For comparison, a new combined-cycle power plant using natural gas can generate electricity for about 4¢ to 5¢/kWh. These generation costs are based on large-scale power plants and would be higher for smaller federal power plants.

Tables 3 and 5 provide examples of the economic impacts of biomass cofiring projects for power and heating, respectively. Federal boilers are most likely to be similar to the 15 MW stoker in Table 3 for power generation, and results shown in Table 5 for heating. The stoker unit and the two 120,000 lb/hr boilers in Table 5 are similar in terms of rated steam generating capacity. At coal costs of \$2.10/MBtu and a delivered biomass cost of \$1.25/MBtu, payback periods would be between one and three years for low-cost stoker installations. The payback period for a higher cost stoker installation, like the one shown in Table 4, row 2, would be about 5.3 years.

All these examples of stoker boilers assume that 20% of the heat input to the boiler is obtained from biomass. Annual fuel cost savings thus range from about \$60,000 to \$110,000 for a typical federal boiler. Payback periods and annual savings for power-generating boilers tend to be more favorable than similarly sized heating boilers, because they are usually used fairly consistently throughout the year, and thus they consume more fuel.

Utility Incentives

At present, there are no known utility incentives for biomass cofiring at federal facilities.

Project Financing and Technical Assistance

DOE FEMP, with support from staff at national laboratories and DOE Regional Offices, can provide many services and resources to help federal agencies implement energy efficiency and renewable energy projects. Projects can be funded through energy savings performance contracts (ESPCs), utility energy service contracts, or appropriations. Among these resources is a technology-specific “Super ESPC” for Biomass and Alternative Methane Fuels (BAMF), which facilitates the use of biomass and alternative methane fuels to reduce federal energy consumption and energy-related costs.

For this Super ESPC, biomass fuels include any organic matter that is available on a renewable or recurring basis (excluding old-growth timber). Examples include dedicated energy crops and trees, agricultural food and feed crop residues, aquatic plants, wood and wood residues, animal wastes, and other waste materials. Alternative methane fuels include landfill methane, wastewater treatment digester gas, and coal-bed methane.

Through a standard ESPC, an energy services company (ESCO) arranges financing to develop and carry out energy and water efficiency and renewable energy projects. This allows federal energy and facility managers to improve buildings and install new equipment at no up-front cost. As part of the project, the ESCO conducts

a comprehensive energy audit and identifies improvements that will save energy and reduce utility bills at the facility. The ESCO guarantees that energy improvements will result in a specified level of annual cost savings to the federal customer and that these savings will be sufficient to repay the ESCO for initial and ongoing work over the term of the contract. In other words, agencies use a portion of their guaranteed energy cost savings to pay for facility improvements and specified maintenance over the life of the contract. After the contract ends, additional cost savings accrue to the agency. Contract terms can be up to 25 years, depending on the scope of the project.

Recognizing that awarding a stand-alone energy savings performance contract (ESPC) can be complex and time-consuming, FEMP created streamlined Super ESPCs. These “umbrella” contracts are awarded to ESCOs selected through a competitive bidding process on a regional or technology-specific basis. Super ESPCs thus allow agencies to bypass the initial competitive bidding process and to undertake multiple energy projects under one contract. Each Super ESPC project is designed to meet the specific needs of a facility; it can include a wide range of energy- and cost-saving improvements, from energy-efficient lighting to heating and cooling systems.

Technology-Specific Super ESPCs focus on technologies that promise substantial energy savings. The technologies are well suited for application in federal facilities, but they are usually not well enough established in the marketplace to be readily available

through routine acquisition processes. The ESCOs that have been awarded technology-specific Super ESPC contracts have demonstrated their expertise in the application of these technologies through past performance, such as proposing and carrying out specific projects defined in DOE's requests for proposals.

Through the BAMF Super ESPC, FEMP helps to make accessible to federal facilities the energy- and cost-savings benefits of biomass and alternative methane fuels. Projects carried out under the BAMF Super ESPC can reduce federal energy costs by utilizing biomass and alternative methane fuels in a variety of applications, such as steam boilers, hot-water heaters, engines, and vehicles. The federal facility, the ESCO, or a third party could own the biomass or alternative methane fuel resource. If the fuel requires transport to end-use equipment, that equipment must be located on federal property.

As discussed earlier, some projects may modify or replace existing equipment so that the facility can supplant or supplement its conventional fuel supply with a biomass or alternative methane fuel. In other projects, ESCOs could install equipment that uses these fuels to accomplish something altogether new at a federal facility, such as on-site power generation. Although the primary component of any project under this Super ESPC must feature the use of a biomass or alternative methane fuel, all projects are also expected to employ a variety of traditional conservation measures, which include retrofits to lighting, motors, and heating,

ventilation, and cooling systems in order to reduce energy costs.

For further information, see the FEMP and BAMF Super ESPC contacts listed on page 24. See also the list of manufacturers for BAMF Super ESPC contract awardees.

Technology Performance

In general, facility managers who have cofired biomass in coal-fueled boilers have been pleased with the technology's operation, once initial testing and performance verification activities have been completed. They cite the ease of retrofitting their operations to accommodate biomass and the various cost savings and emissions benefits as factors that have made their projects worthwhile.

Field Experience

Biomass cofiring has been successfully demonstrated and practiced in a full range of coal boiler types and sizes, including pulverized-coal boilers, cyclones, stokers, and fluidized beds. At least 182 separate boilers and organizations in the United States have cofired biomass with fossil fuels; although this number is not comprehensive, it is based on the most thorough and current list available. Much of this experience has been gained as a result of the energy crisis of the 1970s, when many boiler plant operators were seeking ways to reduce fuel costs. However, a steady number of organizations have continued cofiring operations to reduce their overall operating costs. Of the 182 cofiring operations mentioned above, 114 (or 63%) have been at industrial facilities, 32 at

utility-owned power plants, 18 at municipal boilers, 10 at educational institutions, and 8 at federal facilities. The majority of cofiring projects have occurred in industrial applications. These are primarily in the wood products, agricultural, chemical, and textile industries, in which companies generate a biomass waste by-product such as sawdust, scrap wood, or agricultural residues. By using the waste material as fuel, the companies avoid a certain amount of fossil-fuel purchases and disposal costs.

Several U.S. power generators are either considering or actually using economical forms of biomass as supplemental fuels in coal-fired boilers. These generators include the Tennessee Valley Authority (TVA), New York State Electric and Gas, Northern States Power, Tacoma City Light, and Southern Company. The TVA expects annual fuel cost savings of about \$1.5 million as a result of cofiring at the Colbert pulverized-coal power plant in Alabama.

Currently, federal facilities use very little biomass energy. Because of DOE FEMP's commitment to reducing energy costs and environmental emissions at federal facilities, the program is working to add biomass cofiring to the portfolio of options for improving the economic and environmental performance of these facilities.

Fuel Supply and Cost Savings Calculations

Appendix B contains worksheets and supporting data for agencies to evaluate the feasibility of a biomass cofiring operation in a preliminary manner. These worksheets were designed to permit useful calculations based

on information that is readily available at any coal-fueled boiler plant.

The first worksheet in Appendix B is for estimating the amount of biomass fuel supply needed for a cofiring application. This can be used to determine the size of biomass processing equipment required and to evaluate local biomass supplies in relation to the biomass fuel requirements of the cofiring project. The second worksheet in Appendix B is for determining the annual cost savings resulting from cofiring with biomass at a coal-fired facility.

Appendix C provides examples of completed worksheets estimating annual cost savings and biomass fuel supplies for DOE's Savannah River Site cofiring project. This project is illustrated in the following case study.

Case Study

Savannah River Cofiring Project Facility Description

The primary function of the Department of Energy's Savannah River Site (SRS)—constructed during the early 1950s in Aiken, South Carolina—is to handle, recycle, and process basic nuclear materials such as tritium and plutonium. The Site Utilities Department at SRS is implementing an innovative, cost-effective system for cofiring biomass with coal in the site's existing coal-fired stoker boilers. The system converts paper and wood waste generated from the day-to-day operations of the site into “process engineered fuel” (PEF) cubes, which will replace about 20% of the coal used at the steam plant.

Existing Technology Description

Savannah River Site uses two moving-grate spreader stoker boilers to produce steam. The boilers were manufactured by Combustion Engineering and have a capacity of 60,000 lb/hr at full load. Fuel is fed to the facility from two track hoppers of equal size, located next to the boiler plant. Steam from the boilers is required year-round for process heating applications. Steam demands peak during winter as a result of extra comfort-heating loads. Multiclones remove particulates from the stack gases. Before the PEF project, the boilers used only coal for fuel, and average annual coal use at the facility was about 11,145 tons. At a delivered price of \$50 per ton, this coal cost the site just over \$550,000 per year.

Like many other facilities its size, SRS generates significant quantities of scrap paper and cardboard products—about 280 tons per month. In the years before implementing the PEF cofiring project, SRS had been paying about \$23 per ton to landfill these materials. Landfill costs for the paper waste amounted to about \$77,280 per year. In addition, the site burned about 70 tons per month of recently unclassified paper in an on-site burn pit. The annual cost of operating the burn pit was about \$83,050.

These high waste-disposal costs, combined with

directives in Executive Order 13123 to increase the use of renewable energy and reduce emissions, compelled SRS to pursue the PEF project.

New Technology Description

The PEF Facility uses a shredder and a cubing machine (see Figure 9) to convert waste paper into cubes that can be used as fuel in the SRS stoker boilers. The cuber greatly increases the bulk density of the waste materials and makes them compatible with fuel conveyors and handling equipment at the steam plant.

The PEF Facility has two major handling sections: the tipping floor, where the PEF feedstock is delivered, and the processing line, which forms the feedstock into cubes. Waste paper is collected in plastic bags from facility offices. The plastic bags containing the waste paper products are then loaded into dumpsters marked “PAPER PRODUCTS ONLY.” These dumpsters are



Figure 9. The PEF Facility has a shredder and a cubing machine to convert waste paper into cubes used for fuel in SRS stoker boilers.

collected by trucks that bring this material directly to the PEF facility tipping floor. Because previous landfill disposal activities for paper required the same amount of collection and transportation, no new costs were incurred by diverting the waste material from the landfill to the PEF Facility.

After they are delivered to the tipping floor, the plastic bags containing waste paper are pushed into a hopper. The hopper drops the paper onto a conveyor that delivers it to a shredder. The waste paper is shredded in a 300-hp high-speed shredder that yields pieces no larger than 2 in. in length, width, or depth. Water sprays and/or dry granular material can easily be added to the shredded paper to incorporate emission-reducing agents into the cubes. A dust collection system filters air from the shredder, feedstock metering box, and cuber. Dust is removed from the airflow in a cyclone separator and a baghouse filter before being vented to the atmosphere.

The combined feedstock material is processed through a machine that extrudes it into cubes approximately 1 in. square and 3 to 4 in. long. The cubing machine can be modified to produce cubes from 1/4 to 1 in. square. Sample cubes are shown in the inset of Figure 10. From left to right, the cubes shown in the inset are made of wood, cardboard, and office paper.

The initial bulk density of shredded paper is only about 2 to 4 lb/ft³. The bulk density of the PEF cubes at SRS is from 35 to 40 lb/ft². The bulk density of the coal used in the SRS boilers is 80 lb/ft². The PEF cubes have



Figure 10. The combined feedstock material is processed through a machine that extrudes it into cubes approximately 1 in. square and 3 to 4 in. long. Sample cubes shown in the inset (left to right) are made of wood, cardboard, and office paper.

an average heating value of about 7,500 Btu/lb, compared with 13,000 Btu/lb for the coal. The cost of operating the PEF facility is about \$7.61 per ton of cubes produced.

The PEF cubes are delivered to one of the two track hoppers at the SRS steam plant. Coal is fed from one hopper and PEF cubes are fed from the other. The two fuels are placed in equal volumes onto the conveyor that feeds the bucket elevator. The bucket elevator places the coal/PEF mix into the fuel bunkers, which supply fuel to the boilers.

Energy Savings

This project will not decrease the amount of energy input to the boilers at the steam plant; however, it will replace a significant amount of coal with a renewable fuel made from waste paper that previously had to be disposed of at great expense. The worksheets in Appendix C show the calculations needed to determine that, if the PEF cubes are 50% of the volume of fuel input to the boilers, the heat input obtained from PEF is about 20% of the total. In other words, 20% less coal will be required to produce the same

amount of steam. Since the average annual coal use before the PEF project was about 11,145 tons per year, the annual coal savings will be about 2,240 tons (11,145 x 20% = 2,240). Since the heating value of the coal used at SRS is about 13,000 Btu/lb, the coal-based energy input to the boilers will be reduced by about 58,240 million Btu per year (2,240 tons x 2,000 lb/ton x 13,000 Btu/lb = 58,240 MBtu).

Table 7. Savings from the Savannah River Site Cofiring Project.

Energy Savings	
Coal supply reduced	2,240 tons/yr 58,240 MBtu/yr
Disposal Savings (paper and cardboard)	
PEF cube supply	3,880 tons/yr
Savings Source	
Reduced coal costs	\$112,000/yr
Reduced landfill costs	\$89,000/yr
Burn pit closure	\$83,000/yr
PEF processing costs	(\$30,000/yr)
Total Cost Savings	
	\$254,000/yr

Life-Cycle Cost

Design, construction, and equipment purchases for the PEF Facility totaled about \$850,000. The net annual cost savings generated by the project are expected to be about \$254,000. These savings are the result of reduced coal purchases, reduced landfill costs, and elimination of burn-pit operational costs. Operating the PEF Facility will cost about \$30,000 per year. All expected costs and savings are summarized in Table 7, and associated calculations are shown in the annual cost savings worksheet in Appendix C.

Based on a National Institute of Standards and Technology (NIST) Building Life-Cycle Costing (BLCC) comparative economic analysis (see Appendix E), the net present value of the project, based on a 10-year analysis period, will be more than \$1.1 million. With a savings-to-investment ratio of 2.3, the project is cost-effective according to federal criteria (W CFR 43G). The simple payback period for the project will be less than 4 years. (For details, see the federal life-cycle costing procedures in Appendix D and the NIST BLCC comparative analysis in Appendix E.)

Performance Test Results

As of February 2003, all equipment had been installed and tested at the SRS, and the facility is in preliminary startup mode. The equipment installed at the SRS PEF Facility was previously used in a similar coal-and-biomass cofiring demonstration project at INEEL in Idaho. The equipment operated well for more than a year at INEEL, but its use was discontinued when the steam plant was closed because of privatization of the utility. When the equipment was used at INEEL, PEF cubes provided about 25% (by volume) of the fuel at the steam plant, and no major operational problems were encountered.

Test burns at the SRS have shown that no modifications were needed to current stoker boiler fuel-handling equipment to successfully fire the PEF/coal mixture. No fuel-feeding problems were experienced, and no increase in maintenance is expected to be necessary at the steam plant.

Emissions measurements made during initial tests showed level or reduced emissions for all eight measured pollutants. Because of the low (nearly zero) sulfur content of wood and paper, sulfur emissions are expected to decrease. Sulfur emissions are reduced on a one-to-one basis with the fraction of heat input obtained from biomass; i.e., obtaining 20% of the plant's total heat input from PEF cubes will reduce sulfur emissions by 20%. Opacity levels were also noticed to decrease significantly.

SRS steam plant personnel have supported the project. In 2003, permitting officials in South Carolina licensed SRS for one year of operation and evaluation, after a

review of emissions test results and procedures for material collection and handling. The project manager hopes the facility will be licensed by South Carolina for long-term operation at high levels of biomass input by the end of 2004.

The Technology in Perspective

Biomass cofiring has good potential for use at federal facilities with existing coal-fired boilers. Advantages to federal facilities that accrue from using biomass cofiring technology can include reductions in fuel, operating, and landfill costs, as well as in emissions, and increases in their use of domestic renewable energy resources. Cofiring biomass with coal is expected to become more widespread as concerns for energy security and the environment become greater within agencies of the federal government.

By replacing coal with less expensive biomass fuels, a federal facility can reduce air emissions such as NO_x, SO₂, and greenhouse gases. Cofiring with biomass also provides facility managers with a near-term renewable energy option, and it reduces their fuel price risk by diversifying the fuel supply. Cofiring also allows facilities to make use of local fuel supplies. Finally, only a minimum number of modifications to existing equipment and operational procedures (if any) are required, for the most part, to adapt a boiler to cofiring with biomass. When new equipment is needed, proven technologies are readily available.

Manufacturers

The following list includes companies identified as manufacturers of biomass cofiring equipment. We made every effort to identify current manufacturers; however, this listing is not purported to be complete or to reflect future market conditions. Please see the *Thomas Register* (www.thomasregister.com) for more information.

Biomass Pelletizing Equipment

Bliss Industries

P.O. Box 910
Ponca City, OK 74602
Phone: 580-765-7787
www.bliss-industries.com

Cooper Equipment Inc.

227 South Knox Drive
Burley, ID 83318
Phone: 208-678-8015

CPM Acquisitions Group

2975 Airline Circle
Waterloo, IA 50703
Phone: 319-232-8444
www.cpmroskamp.com

Sprout Matador, Div. of Andritz

35 Sherman Street
Muncy, PA 17756-1202
Phone: 570-546-5811
www.sprout-matador.com

UMT (Universal Milling Technology) Inc.

8259 Melrose Drive
Lenexa, KS 66214
Phone: 913-541-1703
www.umat-group.com

Boiler Equipment/Cofiring Systems

ALSTOM Power Inc.

(Formerly, ABB-Combustion Engineering Inc.)
2000 Day Hill Road
P.O. Box 500
Windsor, CT 06095
Phone: 860-285-3654
www.power.alstom.com

The Babcock & Wilcox Company

20 South Van Buren Avenue
Barberton, OH 44203-0351
Phone: 800-BABCOCK
www.babcock.com

Babcock Borsig Power

(Formerly DB Riley, Inc.)
5 Neponset Street
Worcester, MA 01606
Phone: 508-852-7100
www.dbriley.com

Detroit Stoker Company

1510 East First Street
P.O. Box 732
Monroe, MI 48161
Phone: 800-STOKER4
www.detroitstoker.com

Foster Wheeler Corporation

Perryville Corporate Park
P.O. Box 4000
Clinton, NJ 08809-4000
Phone: (908) 730-4000
www.fwc.com

SNC-Lavalin Constructors Inc.

(Formerly Zurn/NEPCO)
P.O. Box 97008
Redmond, WA 98073-9708
Phone: 425-896-4000
www.nepco.com

Biomass and Alternative Methane Fuels (BAMF) Super ESPC Competitively Awarded Contractors

Constellation Energy Source

7133 Rutherford Rd.
Suite 401
Baltimore, MD 21244
Phone: 410-907-2002

DTE Biomass Energy, Inc.

54 Willow Field Drive
North Falmouth, MA 02556
Phone: 508-564-4197

Energy Systems Group

101 Plaza East Boulevard
Suite 320
Evansville, IN 47715
Phone: 812-475-2550 x2541

Systems Engineering and Management Corp.

1820 Midpark Road, Suite C
Knoxville, TN 37921-5955
Phone: 865-558-9459

Trigen Development Corporation

One North Charles Street
Baltimore, MD 21201
Phone: 937-256-7378

For Further Information

For more information about the BAMF Super ESPC, contact:

Christopher Abbuehl
National BAMF Program
Representative
U.S. Department of Energy
Philadelphia Regional Office
100 Penn Square East, Suite 890
Philadelphia, PA 19107
Phone: 215-656-6995
E-mail:
christopher.abbuehl@ee.doe.gov

See also the following U.S. Government Web sites:
www.eere.energy.gov/biopower/main.html
www.eere.energy.gov/states

Bibliography

Antares Group Inc. (2000), *The Cofiring Connection* (CD-ROM compendium of technical papers on biomass cofiring), prepared for the U.S. Department of Energy Biomass Power Program.

Antares Group Inc. (May 1999), *Strategic Plan and Analysis for Biomass Cofiring at Federal Facilities*, prepared for the National Renewable Energy Laboratory, Task Order No. KAW-5-15061-01.

Antares Group Inc. (June 1999), *Biomass Residue Supply Curves for the United States*, prepared for the U.S. Department of Energy's Biomass Power Program and the National Renewable Energy Laboratory, Task Order No. ACG-7-17078-07.

Thompson, J. (updated annually), *Directory and Atlas of Solid Waste Disposal Facilities*, Chartwell Information Publishers, Alexandria, VA.

Cobb, J., et al. (Oct. 1999), "Demonstration of Wood/Coal Cofiring in a Spreader Stoker," *Sixteenth Annual Pittsburgh Coal Conference Proceedings*, University of Pittsburgh, Pittsburgh, PA.

Cobb, J., et al. (June 1999), "Wood/Coal Cofiring in Industrial Stoker Boilers," *Proceedings of the of the Air and Waste Management Association's 1999 Annual Meeting and Exhibition*, St. Louis, MO.

Comer, K. (Dec. 1997), "Biomass Cofiring," *Renewable Energy Technology Characteristics*, EPRI Topical Report No. TR-109496, Palo Alto, CA.

Electric Power Research Institute, et al. (1999), *Biomass Cofiring: Field Test Results*, EPRI Topical Report No. TR-113903, Palo Alto, CA.

Giaier, T., and Eleniewski, M. [Detroit Stoker Company] (Sept. 1999), "Cofiring Biomass with Coal Utilizing Water-Cooled

Vibrating Grate Technology," *Proceedings of the 4th Biomass Conference of the Americas*, Elsevier Science Ltd., Oxford, UK.

Idaho National Engineering and Environmental Laboratory (1999), *Waste-to-Energy Paper Cuber Project*, Award Application to the American Academy of Environmental Engineers, U.S. Department of Energy, Idaho Operations Office, Idaho Falls, ID.

Liu, H. (Feb. 2000), *Economic Analysis of Compacting and Transporting Biomass Logs for Cofiring with Coal in Power Plants*, Capsule Pipeline Research Center, College of Engineering, University of Missouri-Columbia, CPRC Report No. 2000-1.

Makansi, J. (July 1987), "Co-combustion: Burning biomass, fossil fuels together simplifies waste disposal, cuts fuel cost," Power, McGraw-Hill, New York, NY.

Miles, T. R.; Miles, T. R. Jr.; Baxter, L. L.; Bryers, R. W.; Jenkins, B. M.; Oden, L. L.; Dayton, D. C.; Milne, T. A. (1996), *Alkali Deposits Found in Biomass Power Plants. A Preliminary Investigation of Their Extent and Nature (Vol. I); The Behavior of Inorganic Material in Biomass-Fired Power Boilers—Field and Laboratory Experiences (Vol. II)*, Vol. I: 133 pp.; Vol II: 496 pp.; prepared for the National Renewable Energy Laboratory, NREL Report No. TP-433-8142; Golden, CO.

Mitchell, C.P., Overend, R.P., and Tillman, D.A. (2000), "Cofiring Benefits for Coal and Biomass," *Biomass & Bioenergy (special issue)*, Vol. 19, No. 6, Elsevier Science Ltd., Oxford, UK.

Muschick, R. (Oct. 1999), *Alternate Fuel Facility Economic Study*, Westinghouse Savannah River Company Site Utilities Department, Aiken, SC.

Tillman, D.A. (ed.) (2000), "Cofiring Benefits for Coal and Biomass," *Biomass & Bioenergy (special issue)*, Vol. 19, No. 6, Elsevier Science Ltd., Oxford, UK.

Tillman, D., Plasynski, S., and Hughes, E. (Sept. 1999), "Biomass Cofiring In Coal-Fired Boilers: Summary of Test Experiences," *Proceedings of the 4th Biomass Conference of the Americas*, Elsevier Science Ltd., Oxford, UK.

Walsh, M., et al. (January 2000), *Biomass Feedstock Availability in the United States: 1999 State Level Analysis*, Oak Ridge National Laboratory, Oak Ridge, TN.

Wiltsee, G. (Nov. 1998), *Urban Wood Waste Resource Assessment*, prepared for the National Renewable Energy Laboratory, NREL/SR-570-25918, Golden, CO.

Appendix A

Assumptions and Explanation for Screening Analysis

Average delivered state coal prices were obtained from the Department of Energy's Energy Information Administration. Estimated state-level low-cost biomass residue supplies were obtained from *Biomass Residue Supply Curves for the United States* (Antares Group Inc., June 1999). Average state landfill tipping fees were obtained from Chartwell Information Publishers.

Data for coal costs, biomass supplies, and tipping fees were normalized on a 100-point scale for each of the 50 states to capture the relative variation in each item from one state to the next. Weighting factors (ranging from one to three) were then applied to the normalized coal cost, biomass supply, and tipping fee data to account for the varying importance of these items in terms of the economics of a potential cofiring project.

Typically, coal cost was weighted the highest, followed by biomass supply and then tipping fees. The weighted values for the normalized coal cost, biomass supply, and tipping fees were then summed together for each state, and the state rankings were based on these totals. A wide range of weighting-factor combinations were attempted to test the sensitivity of the screening tool, including a case in which coal costs, biomass supplies, and tipping fees were weighted equally.

This process showed that, although there were slight changes in the ordering of the states from one set of weighting factors to the next, the relative ranking of each state was very stable from trial to trial over a wide combination of weighting factors. In general, states with high coal costs, high biomass supplies, and high tipping fees ranked very high, while those with low coal costs, low biomass supplies, and low tipping fees ranked very low.

Appendix B

Blank Worksheets for Preliminary Evaluation of a Cofiring Project

Biomass Fuel Supply Estimation Worksheet

The amount of biomass needed for a cofiring application depends on the size of the boiler, its loading, the cofiring rate (biomass/coal blend), and the type of biomass used. Biomass fuel supplies required for a cofiring operation can be estimated as follows, if the rate of coal use in the boiler, the heating value and density of the coal, the biomass/coal blend (or cofiring rate), and the heating value and density of the biomass are known.

DCF _{max} = daily coal feed rate at maximum rated load	_____	tons/day
DCF _{ave} = daily coal feed rate at average operating load (based on operating history)	_____	tons/day
ACU = annual coal use (based on operating history)	_____	tons/year
HV _c = average heating value of coal	_____	Btu/lb
BD _c = bulk density of coal	_____	lb/ft ³
HV _b = average heating value of biomass fuel(s)	_____	Btu/lb
BD _b = bulk density of biomass	_____	lb/ft ³

If actual data are not available for HV_c, BD_c, HV_b, and BD_b, use the table below to estimate them.

Fuel Type	Example Fuel	As-received Heating Value (Btu/lb)	Bulk Density (lb/ft ³)
Dry biomass (10% moisture)	Chipped pallets	7,500	12.5
Moist biomass (30% moisture)	Slightly air-dried wood chips or sawdust	6,000	15.0
Wet biomass (50% moisture)	Fresh ("green") wood chips or sawdust	4,500	17.5
Pelletized or cubed biomass	Paper or sawdust cubes	7,500 to 8,500	40
Coal	Stoker coal	13,000	80

Fill in one of the following three blanks and use the indicated equations to compute the other two values:

H_b = % biomass, heat basis (% of total heat provided by biomass)____%, use Eq. 1 and 2 to obtain M_b and V_b

M_b = % biomass, mass basis (% of total fuel mass that is biomass)____%, use Eq. 2 and 3 to obtain V_b and H_b

V_b = % biomass, volume basis (% of total fuel volume that is biomass)____%, use Eq. 4 and 3 to obtain M_b and H_b

To determine the cofiring rate (percent biomass) on a mass, heat, and volume basis:

After selecting a desired/target cofiring rate on either a mass (M_b), heat (H_b), or volume (V_b) basis, use two of the following equations to estimate the cofiring rate in the other units of measure:

$$M_b = H_b \times \frac{1/HV_b}{\frac{H_b}{100 \times HV_b} + \left(1 - \frac{H_b}{100}\right)/HV_c} = \left(\frac{\quad}{\quad}\right) \times \frac{1/(\quad)}{\frac{(\quad)}{100 \times (\quad)} + \left(1 - \frac{(\quad)}{100}\right)/(\quad)} = \frac{\quad}{\quad}$$

$$V_b = M_b \times \frac{1/BD_b}{\frac{M_b}{100 \times BD_b} + \left(1 - \frac{M_b}{100}\right)/BD_c} = \left(\frac{\quad}{\quad}\right) \times \frac{1/(\quad)}{\frac{(\quad)}{100 \times (\quad)} + \left(1 - \frac{(\quad)}{100}\right)/(\quad)} = \frac{\quad}{\quad}$$

$$H_b = M_b \times \frac{HV_b}{\frac{M_b}{100} \times HV_b + \left(1 - \frac{M_b}{100}\right) \times HV_c} = \left(\frac{\quad}{\quad}\right) \times \frac{(\quad)}{\frac{(\quad)}{100} \times (\quad) + \left(1 - \frac{(\quad)}{100}\right) \times (\quad)} = \frac{\quad}{\quad}$$

$$M_b = V_b \times \frac{BD_b}{\frac{V_b}{100} \times BD_b + \left(1 - \frac{V_b}{100}\right) \times BD_c} = \left(\frac{\quad}{\quad}\right) \times \frac{(\quad)}{\frac{(\quad)}{100} \times (\quad) + \left(1 - \frac{(\quad)}{100}\right) \times (\quad)} = \frac{\quad}{\quad}$$

The following equations allow you to estimate key biomass fuel supply rates in three units of measure: tons, cubic feet (ft^3), and cubic yards (yd^3). These numbers may be useful when sizing equipment, scheduling fuel deliveries, and obtaining biomass supply prices.

Maximum Daily Biomass Requirements:

DBF_{\max} = daily biomass feed rate at maximum rated load (multiple units)

$$DBF_{\max} = DCF_{\max} \times \frac{HV_c}{HV_b} \times \frac{H_b}{100\%} = \left(\frac{\quad}{\quad}\right) \times \frac{(\quad)}{(\quad)} \times \frac{(\quad)}{100\%} = \frac{\quad}{\quad} \frac{\text{tons}}{\text{day}}$$

$$DBF_{\max} = \left(\frac{\quad}{\quad} \frac{\text{tons}}{\text{day}}\right) \times \frac{2000}{BD_b} = \left(\frac{\quad}{\quad} \frac{\text{tons}}{\text{day}}\right) \times \frac{2000}{(\quad)} = \left(\frac{\quad}{\quad} \frac{\text{ft}^3}{\text{day}}\right) \times \frac{1}{27} = \frac{\quad}{\quad} \frac{\text{yd}^3}{\text{day}}$$

Average Daily Biomass Requirements:

$$DBF_{avg} = DCF_{avg} \times \frac{HV_c}{HV_b} \times \frac{H_b}{100\%} = \left(\frac{\quad}{\quad} \right) \times \left(\frac{\quad}{\quad} \right) \times \left(\frac{\quad}{100\%} \right) = \frac{\quad \text{ tons}}{\text{ day}}$$

$$DBF_{avg} = \left(\frac{\quad \text{ tons}}{\text{ day}} \right) \times \frac{2000}{BD_b} = \left(\frac{\quad \text{ tons}}{\text{ day}} \right) \times \left(\frac{2000}{\quad} \right) = \left(\frac{\quad \text{ ft}^3}{\text{ day}} \right) \times \frac{1}{27} = \frac{\quad \text{ yd}^3}{\text{ day}}$$

DBF_{avg} = daily biomass feed rate at average rated load (multiple units)

Annual Biomass Requirements:

$$ABU = ACU \times \frac{HV_c}{HV_b} \times \frac{H_b}{100\%} = \left(\frac{\quad}{\quad} \right) \times \left(\frac{\quad}{\quad} \right) \times \left(\frac{\quad}{100\%} \right) = \frac{\quad \text{ tons}}{\text{ yr}}$$

$$ABU = \left(\frac{\quad \text{ tons}}{\text{ yr}} \right) \times \frac{2000}{BD_b} = \left(\frac{\quad \text{ tons}}{\text{ yr}} \right) \times \left(\frac{2000}{\quad} \right) = \left(\frac{\quad \text{ ft}^3}{\text{ yr}} \right) \times \frac{1}{27} = \frac{\quad \text{ yd}^3}{\text{ yr}}$$

ABU = annual biomass use (multiple units)

Annual Cost Savings Estimation Worksheet

ACU = annual coal use (based on operating history) _____ tons/yr

H_b = % biomass, heat basis (% of total heat provided by biomass) _____ %

UC_{coal} = unit cost of coal delivered to the boiler facility _____ \$/ton

ABU = annual biomass use proposed/estimated for boiler facility _____ tons/yr

UC_{biomass} = unit cost of biomass delivered to the boiler facility _____ \$/ton

TF = average tipping fee avoided by diverting biomass from landfill _____ \$/ton

C_{other} = other annual costs associated with using biomass (\$/yr) _____ \$/yr
(not including the cost of delivered biomass; could include increased power consumption by material handling and processing equipment, additional labor costs associated with using biomass, etc.)

CS_{other} = other annual cost savings associated with using biomass (\$/yr) _____ \$/yr
(could include reduced biomass waste handling and transportation costs, recycling savings associated with the new method of handling biomass, etc.)

Annual Cost Savings

CS_{coal} = annual cost savings from reduced coal consumption (\$/yr)

$$CS_{coal} = ACU \times \frac{H_b}{100} \times UC_{coal} = (\text{_____}) \times \frac{(\text{_____})}{100} \times (\text{_____}) = \$ \text{_____} / yr$$

C_{biomass} = annual cost of biomass delivered to the boiler facility (\$/yr)

$$C_{biomass} = ABU \times UC_{biomass} = (\text{_____}) \times (\text{_____}) = \$ \text{_____} / yr$$

CS_{landfill} = annual cost savings from avoided landfill fees (\$/yr)

$$CS_{landfill} = ABU \times TF = (\text{_____}) \times (\text{_____}) = \$ \text{_____} / yr$$

CS_{total} = total annual cost savings (\$/yr)

$$CS_{total} =$$

$$CS_{coal} - C_{biomass} + CS_{landfill} + CS_{other} - C_{other}$$

$$CS_{total} =$$

$$(\text{_____}) - (\text{_____}) + (\text{_____}) + (\text{_____}) - (\text{_____})$$

$$CS_{total} = \$ \text{_____} / yr$$

Appendix C

Completed Worksheets for Cofiring Operation at Savannah River Site

Biomass Fuel Supply Estimation Example (from Appendix B)

The amount of biomass needed for a cofiring application depends on the size of the boiler, its loading, the cofiring rate (biomass/coal blend), and the type of biomass used. Biomass fuel supplies required for a cofiring operation can be estimated as follows, if the rate of coal use in the boiler, the heating value and density of the coal, the biomass/coal blend (or cofiring rate), and the heating value and density of the biomass are known.

DCF _{max} = daily coal feed rate at maximum rated load	110	tons/day
DCF _{ave} = daily coal feed rate at average operating load (based on operating history)	31	tons/day
ACU = annual coal use (based on operating history)	11,145	tons/year
HV _c = average heating value of coal	13,000	Btu/lb
BD _c = bulk density of coal	80	lb/ft ³
HV _b = average heating value of biomass fuel(s)	7,500	Btu/lb
BD _b = bulk density of biomass	40	lb/ft ³

If actual data is not available for HV_c, BD_c, HV_b, and BD_b, use the table below for estimates.

Fuel Type	Example Fuel	As-received Heating Value (Btu/lb)	Bulk Density (lb/ft ³)
Dry Biomass (10% moisture)	Chipped Pallets	7,500	12.5
Moist Biomass (30% moisture)	Slightly air-dried wood chips or sawdust	6,000	15.0
Wet Biomass (50% moisture)	Fresh ("green") wood chips or sawdust	4,500	17.5
Pelletized or Cubed Biomass	Paper or sawdust cubes	7,500 to 8,500	40
Coal	Stoker Coal	13,000	80

Fill in one of the following three blanks and use the indicated equations to compute the other two values:

H_b = % biomass, heat basis (% of total heat provided by biomass) _____ %, use Eq. 1 & 2 to get M_b & V_b

M_b = % biomass, mass basis (% of total fuel mass that is biomass) **50** %, use Eq. 2 & 3 to get V_b & H_b

V_b = % biomass, volume basis (% of total fuel volume that is biomass) _____ %, use Eq. 4 & 3 to get M_b & H_b

Determining cofiring rate (percent biomass) on a mass, heat, and volume basis:

After selecting a desired/target cofiring rate on *either* a mass (M_b), heat (H_b), or volume (V_b) basis, two of the following equations will allow you to estimate the cofiring rate in the other units of measure :

$$(Eq.1) \quad M_b = H_b \times \frac{1/HV_b}{\frac{H_b}{100 \times HV_b} + \left(1 - \frac{H_b}{100}\right)/HV_c} = (\underline{\quad}) \times \frac{1/(\underline{\quad})}{\frac{(\underline{\quad})}{100 \times (\underline{\quad})} + \left(1 - \frac{(\underline{\quad})}{100}\right)/(\underline{\quad})} = \underline{\quad}$$

$$(Eq.2) \quad V_b = M_b \times \frac{1/BD_b}{\frac{M_b}{100 \times BD_b} + \left(1 - \frac{M_b}{100}\right)/BD_c} = (\underline{50}) \times \frac{1/(\underline{40})}{\frac{(\underline{50})}{100 \times (\underline{40})} + \left(1 - \frac{(\underline{50})}{100}\right)/(\underline{80})} = \underline{67\%}$$

Biomass fuel supply estimate worksheet, Sheet 1 of 2 (Savannah River case study example)

Biomass Fuel Supply Estimation Example

Determining cofiring rate (percent biomass) on a mass, heat, and volume basis: (continued)

$$\text{(Eq.3)} \quad H_b = M_b \times \frac{HV_b}{\frac{M_b}{100} \times HV_b + \left(1 - \frac{M_b}{100}\right) \times HV_c} = \left(\frac{50}{100}\right) \times \frac{(7500)}{\left(\frac{50}{100}\right) \times (7500) + \left(1 - \left(\frac{50}{100}\right)\right) \times (13000)} = \frac{36.5}{100}$$

$$\text{(Eq.4)} \quad M_b = V_b \times \frac{BD_b}{\frac{V_b}{100} \times BD_b + \left(1 - \frac{V_b}{100}\right) \times BD_c} = \left(\frac{\quad}{100}\right) \times \frac{(\quad)}{\left(\frac{\quad}{100}\right) \times (\quad) + \left(1 - \left(\frac{\quad}{100}\right)\right) \times (\quad)} = \frac{\quad}{100}$$

With the estimate of $M_b = 50\%$ from Sheet 1, V_b and H_b can be found by substituting M_b into Eq.2 and Eq3, respectively.

The following equations will allow estimation of key biomass fuel supply rates in three units of measure: tons, cubic feet (ft^3), and cubic yards (yd^3). These numbers may be useful when sizing equipment, scheduling fuel deliveries, and obtaining biomass supply prices.

Maximum Daily Biomass Requirements:

DBF_{\max} = daily biomass feed rate at maximum rated load (multiple units)

$$DBF_{\max} = DCF_{\max} \times \frac{HV_c}{HV_b} \times \frac{H_b}{100\%} = \left(\frac{110}{100}\right) \times \left(\frac{13000}{7500}\right) \times \left(\frac{36.5}{100}\right) = \frac{69.5}{100} \frac{\text{tons}}{\text{day}}$$

$$DBF_{\max} = \left(\frac{\quad}{100} \frac{\text{tons}}{\text{day}}\right) \times \frac{2000}{BD_b} = \left(\frac{69.5}{100} \frac{\text{tons}}{\text{day}}\right) \times \frac{2000}{(35)} = \left(\frac{3973}{100} \frac{\text{ft}^3}{\text{day}}\right) \times \frac{1}{27} = \frac{147}{100} \frac{\text{yd}^3}{\text{day}}$$

Average Daily Biomass Requirements:

DBF_{avg} = daily biomass feed rate at average rated load (multiple units)

$$DBF_{\text{avg}} = DCF_{\text{avg}} \times \frac{HV_c}{HV_b} \times \frac{H_b}{100\%} = \left(\frac{31}{100}\right) \times \left(\frac{13000}{7500}\right) \times \left(\frac{36.5}{100}\right) = \frac{19.6}{100} \frac{\text{tons}}{\text{day}}$$

$$DBF_{\text{avg}} = \left(\frac{\quad}{100} \frac{\text{tons}}{\text{day}}\right) \times \frac{2000}{BD_b} = \left(\frac{19.6}{100} \frac{\text{tons}}{\text{day}}\right) \times \frac{2000}{(35)} = \left(\frac{1120}{100} \frac{\text{ft}^3}{\text{day}}\right) \times \frac{1}{27} = \frac{42}{100} \frac{\text{yd}^3}{\text{day}}$$

Annual Biomass Requirements:

ABU = annual biomass use (multiple units)

$$ABU = ACU \times \frac{HV_c}{HV_b} \times \frac{H_b}{100\%} = \left(\frac{11145}{100}\right) \times \left(\frac{13000}{7500}\right) \times \left(\frac{36.5}{100}\right) = \frac{7051}{100} \frac{\text{tons}}{\text{yr}}$$

$$ABU = \left(\frac{\quad}{100} \frac{\text{tons}}{\text{yr}}\right) \times \frac{2000}{BD_b} = \left(\frac{7051}{100} \frac{\text{tons}}{\text{yr}}\right) \times \frac{2000}{(35)} = \left(\frac{402,927}{100} \frac{\text{ft}^3}{\text{yr}}\right) \times \frac{1}{27} = \frac{14,923}{100} \frac{\text{yd}^3}{\text{yr}}$$

Biomass fuel supply estimate worksheet, Sheet 2 of 2 (Savannah River case study example)

Annual Cost Savings – Savannah River Case Study

ACU	= annual coal use (based on operating history)	<u>11,145</u> tons/yr
H _b	= % biomass, heat basis (% of total heat provided by biomass)	<u>36.5</u> %
UC _{coal}	= unit cost of coal delivered to the boiler facility	<u>50</u> \$/ton
ABU	= annual biomass use proposed/estimated for boiler facility	<u>7,051</u> tons/yr
UC _{biomass}	= unit cost of biomass delivered to the boiler facility	<u>7.61</u> \$/ton
TF	= average tipping fee avoided by diverting biomass from landfill	<u>23</u> \$/ton
C _{other}	= other annual costs associated with using biomass (\$/yr) (not including the cost of delivered biomass; could include increased power consumption by material handling and processing equipment, additional labor costs associated with using biomass, etc.)	<u>0</u> \$/yr
CS _{other}	= other annual cost savings associated with using biomass (\$/yr) (could include reduced biomass waste handling and transportation costs, recycling savings associated with the new method of handling biomass, etc.)	<u>83,050</u> \$/yr

Annual Cost Savings

CS_{coal} = annual cost savings from reduced coal consumption (\$/yr)

$$CS_{coal} = ACU \times \frac{H_b}{100} \times UC_{coal} = (\underline{11,145}) \times \left(\frac{\underline{36.5}}{100} \right) \times (\underline{50}) = \$ \underline{203,396} / yr$$

C_{biomass} = annual cost of biomass delivered to the boiler facility (\$/yr)

$$C_{biomass} = ABU \times UC_{biomass} = (\underline{7,051}) \times (\underline{7.61}) = \$ \underline{53,658} / yr$$

CS_{landfill} = annual cost savings from avoided landfill fees (\$/yr)

$$CS_{landfill} = ABU \times TF = (\underline{7,051}) \times (\underline{23}) = \$ \underline{162,173} / yr$$

CS_{total} = total annual cost savings (\$/yr)

$$CS_{total} = CS_{coal} - C_{biomass} + CS_{landfill} + CS_{other} - C_{other}$$

$$CS_{total} = (\underline{203,396}) - (\underline{53,658}) + (\underline{162,173}) + (\underline{83,050}) - (\underline{0})$$

$$CS_{total} = \$ \underline{394,961} / yr$$

Annual cost savings worksheet (Savannah River case study example)

Appendix D

Federal Life-Cycle Costing Procedures and the BLCC Software

Federal agencies are required to evaluate energy-related investments on the basis of minimum life-cycle costs (LCC) (10 CFR part 436). An LCC evaluation computes the total long-term costs of a number of potential actions, and selects the action that minimizes long-term costs. In considering retrofits, using existing equipment is one potential action; this is often called the baseline condition. The LCC of a potential investment is the present value of all of the costs associated with the investment over time.

The first step in calculating the LCC is to identify various costs: installed cost, energy cost, non-fuels operation and maintenance (O&M) costs, and replacement cost. Installed cost includes the cost of materials purchased and the cost of labor, for example, the price of an energy-efficient lighting fixture plus the cost of labor needed to install it. Energy cost includes annual expenditures on energy to operate equipment. For example, a lighting fixture that draws 100 watts (W) and operates 2,000 hours annually requires 200,000 watt-hours (2 kWh) annually. At an electricity price of \$0.10/kWh, this fixture has an annual energy cost of \$20. Non-fuel O&M costs include annual expenditures on parts and activities required to operate the equipment, for example, checking light bulbs in the fixture to see if they are all operating. Replacement costs include expenditures for replacing equipment upon failure, for example, replacing a fixture when it can no longer be used or repaired.

Because LCC includes the cost of money, periodic and other O&M, and equipment replacement costs, energy escalation rates, and salvage value, it is usually expressed as a present value, which is evaluated by

$$LCC = PV(IC) + PV(EC) + PV(OM) + PV(REP)$$

where

PV (x) denotes "present value of cost stream x,"

IC is the installed cost,

EC is the annual energy cost,

OM is the annual non-energy cost, and

REP is the future replacement cost.

Net present value (NPV) is the difference between the LCCs of two investment alternatives, e.g., between the LCC of an energy-saving or energy-cost-reducing alternative and the LCC of the baseline equipment. If the alternative's LCC is less than the baseline's LCC, the alternative is said to have NPV, i.e., it is cost-effective. NPV is thus given by

$$NPV = PV(EC_0) - PV(EC_1) + PV(OM_0) - PV(OM_1) + PV(REP_0) - PV(REP_1) - PV(IC)$$

or

$$NPV = PV(ECS) + PV(OMS) + PV(REPS) - PV(IC)$$

where

subscript 0 denotes the baseline condition,

subscript 1 denotes the energy cost-saving measure,

IC is the installation cost of the alternative (the IC of the baseline is assumed to be zero),

ECS is the annual energy cost savings,

OMS is the annual non-energy O&M savings, and

REPS is the future replacement savings.

Levelized energy cost (LEC) is the break-even price (blended) at which a conservation, efficiency, renewable, or fuel-switching measure becomes cost effective ($NPV \geq 0$). Thus, a project's LEC is given by

$$PV(LEC \cdot EUS) = PV(OMS) + PV(REPS) - PV(IC)$$

where EUS is the annual energy use savings (energy units/yr). Savings-to-investment ratio (SIR) is the total (PV) saving of a measure divided by its installation cost:

$$SIR = (PV(ECS) + PV(OMS) + PV(REPS)) / PV(IC)$$

Some of the tedious effort of LCC calculations can be avoided by using the Building Life-Cycle Cost (BLCC) software developed by NIST. For copies of BLCC, call the FEMP Help Desk at 800-363-3732.

Appendix E

NIST BLCC 5.0 Comparative Economic Analysis

10-Year Case Study Base Case: Coal Only

Alternative: Biomass and Coal Cofiring

General Information

Project name: Westinghouse Savannah River Company Fuel Facility Economic Study
 Project location: South Carolina
 Analysis type: Federal analysis, agency-funded project
 Base date of study: January 1, 2001
 Service date: January 1, 2002
 Study period: 11 years 0 months (January 1, 2001, through December 31, 2011)
 Discount rate: 3.4% (assumes initial system service date occurs one year after project evaluation begins)
 Discounting convention: End-of-year

Comparison of Present-Value (PV) Costs: PV Life-Cycle Cost

	Base Case	Alternative	Savings
Initial investment costs:			
Capital requirements as of base date	\$0	\$850,000	-\$850,000
Future costs:			
Energy consumption costs	\$4,220,115	\$3,369,685	\$850,430
Recurring and non-recurring OM&R costs:	\$1,333,451	\$219,134	\$1,114,316
Capital replacements	<u>\$0</u>	<u>\$0</u>	<u>\$0</u>
Total PV life-cycle cost	\$5,553,566	\$4,438,819	\$1,114,747

Net Savings from Alternative Compared with Base Case

PV of non-investment savings \$1,864,747
 – Increased total investment \$850,000

Net savings \$1,114,747

Savings-to-investment ratio (SIR): 2.31
 Adjusted internal rate of return: 11.59%

Payback Period

Estimated years to payback (from beginning of service period):
 Simple payback occurs in year 4.
 Discounted payback occurs in year 4.

Energy Savings Summary

Note: Total energy use would remain approximately the same. Figures below indicate reduced coal consumption. Displaced energy from coal will be replaced with energy from renewable biomass.

Energy Type	Average Base Case (MBtu)	Annual Alternative (MBtu)	Consumption Savings (MBtu)	Life-Cycle Savings (MBtu)
Coal	289,800.0	231,400.0	58,400.0	583,760.2

Emissions Reduction Summary

Emission Type	Average Base Case (kg)	Annual Alternative (kg)	Emission Reduction (kg)	Life-Cycle Reduction (kg)
CO ₂	27,478,053.40	21,940,723.11	5,537,330.29	55,350,562.35
SO ₂	235,570.14	188,098.45	47,484.70	474,521.95

About FEMP's New Technology Demonstrations

The Energy Policy Act of 1992 and subsequent Executive Orders mandate that energy consumption in federal buildings be reduced by 35% from 1985 levels by the year 2010. To achieve this goal, the U.S. Department of Energy's Federal Energy Management Program (FEMP) sponsors a series of activities to reduce energy consumption at federal installations nationwide. One of these activities, new technology demonstrations, is tasked to accelerate the introduction of energy-efficient and renewable technologies into the federal sector and to improve the rate of technology transfer.

As part of this effort, FEMP sponsors the following series of publications that are designed to disseminate information on new and emerging technologies:

Technology Focuses—brief information on new, energy-efficient, environmentally friendly technologies of potential interest to the federal sector.

Federal Technology Alerts—longer summary reports that provide details on energy-efficient, water-conserving, and renewable-energy technologies that have been selected for further study for possible implementation in the federal

sector. Additional information on *Federal Technology Alerts* (FTAs) is provided below.

Technology Installation

Reviews—concise reports describing a new technology and providing case study results, typically from another demonstration or pilot project.

Other Publications—we also issue other publications on energy-saving technologies with potential use in the federal sector.

More on Federal Technology Alerts

Federal Technology Alerts, our signature reports, provide summary information on candidate energy-saving technologies developed and manufactured in the United States. The technologies featured in the FTAs have already entered the market and have some experience but are not in general use in the federal sector.

The goal of the FTAs is to improve the rate of technology transfer of new energy-saving technologies within the federal sector and to provide the right people in the field with accurate, up-to-date information on the new technologies so that they can make educated judgments on whether the technologies are suitable for their federal sites.

The information in the FTAs typically includes a description of the candidate technology; the results of its screening tests; a description of its performance, applications, and field experience to date; a list of manufacturers; and important contact information. Attached appendixes provide supplemental information and example worksheets on the technology.

FEMP sponsors publication of the FTAs to facilitate information-sharing between manufacturers and government staff. While the technology featured promises significant federal-sector savings, the FTAs do not constitute FEMP's endorsement of a particular product, as FEMP has not independently verified performance data provided by manufacturers. Nor do the FTAs attempt to chart market activity vis-a-vis the technology featured. Readers should note the publication date on the back cover, and consider the FTAs as an accurate picture of the technology and its performance at the time of publication. Product innovations and the entrance of new manufacturers or suppliers should be anticipated since the date of publication. FEMP encourages interested federal energy and facility managers to contact the manufacturers and other federal sites directly, and to use the worksheets in the FTAs to aid in their purchasing decisions.

Federal Energy Management Program

The federal government is the largest energy consumer in the nation. Annually, in its 500,000 buildings and 8,000 locations worldwide, it uses nearly two quadrillion Btu (quads) of energy, costing over \$8 billion. This represents 2.5% of all primary energy consumption in the United States. The Federal Energy Management Program was established in 1974 to provide direction, guidance, and assistance to federal agencies in planning and implementing energy management programs that will improve the energy efficiency and fuel flexibility of the federal infrastructure.

Over the years, several federal laws and Executive Orders have shaped FEMP's mission. These include the Energy Policy and Conservation Act of 1975; the National Energy Conservation and Policy Act of 1978; the Federal Energy Management Improvement Act of 1988; the National Energy Policy Act of 1992; Executive Order 13123, signed in 1999; and most recently, Executive Order 13221, signed in 2001, and the Presidential Directive of May 3, 2001.

FEMP is currently involved in a wide range of energy-assessment activities, including conducting new technology demonstrations, to hasten the penetration of energy-efficient technologies into the federal marketplace.



A Strong Energy Portfolio for a Strong America

Energy efficiency and clean, renewable energy will mean a stronger economy, a cleaner environment, and greater energy independence for America. Working with a wide array of state, community, industry, and university partners, the U.S. Department of Energy's Office of Energy Efficiency and Renewable Energy invests in a diverse portfolio of energy technologies.

Log on to FEMP's Web site for information about New Technology Demonstrations

www.eere.energy.gov/femp/

You will find links to

- A New Technology Demonstration Overview
- Information on technology demonstrations
- Downloadable versions of publications in Adobe Portable Document Format (pdf)
- A list of new technology projects under way
- Electronic access to a regular mailing list for new products when they become available
- How federal agencies may submit requests to us to assess new and emerging technologies

For More Information

EERE Information Center
1-877-EERE-INF or
1-877-337-3463
www.eere.energy.gov/femp

General Program Contacts

Ted Collins
New Technology Demonstration
Program Manager
Federal Energy Management Program
U.S. Department of Energy
1000 Independence Ave., S.W., EE-92
Washington, DC 20585
Phone: (202)-586-8017
Fax: (202)-586-3000
theodore.collins@ee.doe.gov

Steven A. Parker
Pacific Northwest National Laboratory
P.O. Box 999, MSIN: K5-08
Richland, WA 99352
Phone: (509)-375-6366
Fax: (509)-375-3614
steven.parker@pnl.gov

Technical Contacts and Authors

Sheila Hayter
National Renewable Energy Laboratory
1617 Cole Blvd.
Golden, CO 80401
Phone: (303) 384-7519
E-mail: sheila_hayter@nrel.gov

Stephanie Tanner
National Renewable Energy Laboratory
901 D Street, S.W., Suite 930
Washington, DC 20024
Phone: (202) 646-5218
E-mail: stephanie_tanner@nrel.gov

Kevin Comer and Christian Demeter
Antares Group Inc.
4351 Garden City Drive, Suite 301
Landover, MD 20785
Phone: (301) 731-1900

Produced for the U.S. Department of Energy, Energy Efficiency and Renewable Energy, by the National Renewable Energy Laboratory, a DOE national laboratory

DOE/EE-0288

June 2004

