

MINING

Project Fact Sheet

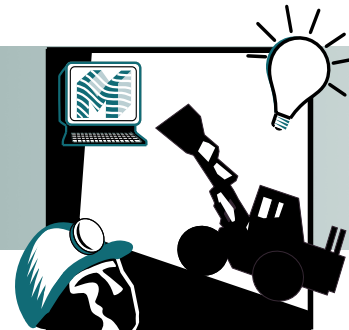

DEVELOPMENT AND DEPLOYMENT OF AUTOMATED MACHINE FLUID ANALYSIS SYSTEMS

BENEFITS

- Decreased equipment life cycle costs
- Energy savings due to reduced down time and more efficient use of operating equipment
- Reduced waste oil streams

APPLICATION

This new technology applies to lubrication and hydraulic oils in all major heavy equipment components.

ON-SITE AND IN-LINE FLUID ANALYSIS SYSTEMS WARN OF FLUID DETERIORATION AND PENDING EQUIPMENT FAILURE

The use of in-line and on-site fluid analysis systems in the mining industry will decrease equipment downtime, reduce total cost of ownership, increase reliability, enable more efficient use of operating equipment and reduce the amount of oil in waste streams. The application of automated oil analysis by smart groups of sensors and miniaturized analytical instruments is being extended to include mine process machinery as well as the equipment used to recover and transport raw materials.

Automated fluid analysis technologies use sensors and sophisticated analytical modules controlled by microprocessors to determine the conditions of machine fluids. Automated fluid analysis technologies help establish a preventative maintenance program based on need rather than a set schedule based on hours of equipment operation. Therefore, maintenance activities are performed when fluid deterioration and equipment wear are detected. As a result, the length of time between maintenance activities increases, less used oil is generated, and unscheduled repair work decreases.

Recently, a great deal of research has focused on developing better sensors and instruments for automated fluid analysis systems and gathering more complete analytical data about fluids and their deterioration. By using these advances, and gathering specific information about these fluids' characteristics in mining equipment, partners will develop an automated fluid analysis system that is specific to mining equipment and conditions. This system will help reduce equipment life cycle costs and equipment downtime.

AUTOMATED ON-SITE ON-BOARD MULTI-PARAMETER MACHINE FLUID ANALYSIS SYSTEM



An Automated on-site on-board machine fluid analysis system shown here features XRF spectroscopy, infrared absorption analyzer, and viscometer.



Project Description

Objective: To implement advanced in-line and on-line systems for machine condition diagnostics and prognostics based on analysis of lubricating oils and hydraulic fluids.

The first step of this project is to adapt and develop the present On-Board Intelligent Lubrication Prognostic (OILPro) system for use in the mining industry. Adaptations will be based on detailed knowledge of ways in which in-service oils and lubricants deteriorate and how best to measure these parameters in mining equipment. The next step is to determine the critical characteristics on hydraulic and powertrain fluids as well as how to measure these key characteristics.

Progress and Milestone

Activities completed in this project include:

- Design, fabrication, and bench testing of an automated, multi-sensor oil analysis system.
- Development and demonstration of sensitive infrared sensor to detect water in oil.

Activities to be completed in this project include:

- Development and deployment of software that allows remote, web-based, expert system analysis data, data archiving as well as human expert review and quality assurances.
- Deployment of full function demonstration system (hardware and software) at an open pit mine.
- Demonstration of laser light extinction sensor for in-situ analysis of particles in hydraulic fluids.
- Further development of the present multi-sensor system for in-line use on-board heavy mining equipment.
- Commercialization of the technology through licensing to a third party manufacturer.



PROJECT PARTNERS

Pacific Northwest National Laboratory
Richland, WA

ASARCO, Inc.
RAY Complex
Hayden, AZ

Oil Analysis Laboratory, Inc.
Spokane, WA

Belhaven Applied Technologies
Kennewick, WA

FOR ADDITIONAL INFORMATION,
PLEASE CONTACT:

Office of Industrial Technologies
Clearinghouse
Phone: (800) 862-2086
Fax: (360) 586-8303
clearinghouse@ee.doe.gov

Visit our home page at
www.oit.doe.gov/mining

Office of Industrial Technologies
Energy Efficiency
and Renewable Energy
U.S. Department of Energy
Washington, D.C. 20585



November 1999
(revised December 2000)

SYSTEM DESIGNED FOR LOCOMOTIVE FLUID ANALYSIS

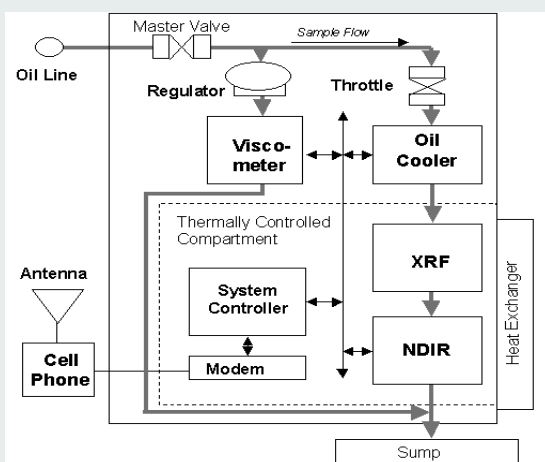

A flow chart of a fluid analysis system designed for locomotive use.