

# **Stability Analysis of a Backfilled Room-and-Pillar Mine**

By D. R. Tesarik, J. B. Seymour, T. R. Yanske, and R. W. McKibbin

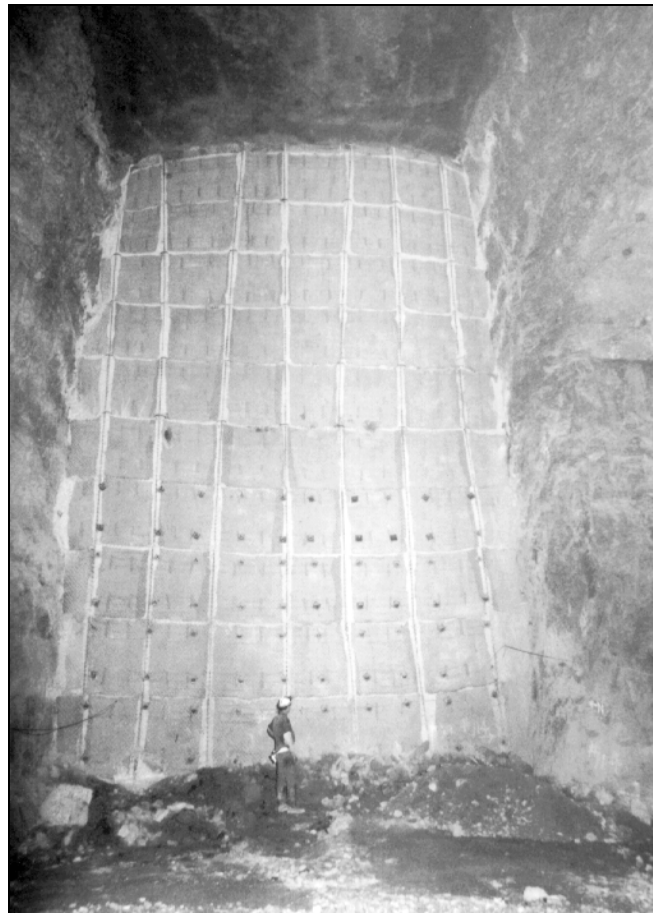

UNITED STATES DEPARTMENT OF THE INTERIOR



UNITED STATES BUREAU OF MINES

***U.S. Department of the Interior  
Mission Statement***

As the Nation's principal conservation agency, the Department of the Interior has responsibility for most of our nationally-owned public lands and natural resources. This includes fostering sound use of our land and water resources; protecting our fish, wildlife, and biological diversity; preserving the environmental and cultural values of our national parks and historical places; and providing for the enjoyment of life through outdoor recreation. The Department assesses our energy and mineral resources and works to ensure that their development is in the best interests of all our people by encouraging stewardship and citizen participation in their care. The Department also has a major responsibility for American Indian reservation communities and for people who live in island territories under U.S. administration.

**Report of Investigations 9565**

# **Stability Analysis of a Backfilled Room-and-Pillar Mine**

**By D. R. Tesarik, J. B. Seymour, T. R. Yanske, and R. W. McKibbin**

**UNITED STATES DEPARTMENT OF THE INTERIOR  
Bruce Babbitt, Secretary**

**BUREAU OF MINES  
Rhea Lydia Graham, Director**



International Standard Serial Number  
ISSN 1066-5552

## CONTENTS

	<i>Page</i>
Abstract .....	1
Introduction .....	2
Buick Mine .....	2
Test area .....	2
Instruments .....	6
Stress determination before pillar removal .....	10
Material property determination .....	11
Numeric models .....	11
Instrument response to mining .....	13
Conclusions .....	19
Acknowledgments .....	20
References .....	20

## ILLUSTRATIONS

1. Location of New Lead Belt .....	3
2. Generalized stratigraphic column in area 5 .....	4
3. Plan view of area 5 .....	5
4. Location of instruments installed in backfill .....	6
5. Location of instruments installed in rock .....	7
6. Vertical backfill extensometer .....	8
7. Vertical section through trapped pillar showing two-point vertical extensometer installed from lower access drift .....	10
8. Microstrain changes in trapped pillars calculated from measured and predicted displacements .....	12
9. Stress changes recorded by earth pressure cells in north section of area 5 .....	14
10. Stress changes recorded by earth pressure cells in south section of area 5 .....	15
11. Strain measured by embedment strain gauge at midheight in backfill and centered on pillars 102, 103, 111, and 112 .....	16
12. Strains measured by embedment strain gauges and vertical extensometers .....	16
13. Measured and predicted vertical strain .....	17
14. Horizontal strain measured between downhole anchors .....	18
15. Vertical strain measured by borehole extensometer in mine roof .....	19

## TABLES

1. Pillar extraction sequence .....	3
2. Instrument location .....	9
3. Measured in situ principal stresses .....	10
4. Measured in situ stress components .....	10
5. Material properties of host rock determined from laboratory tests .....	11
6. Material properties used in program BESOL .....	11
7. Laboratory and estimated material properties for UTAH2 analysis .....	13
8. Maximum compressive stresses recorded by earth pressure cells after installation .....	13
9. Maximum microstrain recorded by embedment strain gauges after installation .....	14
10. Elastic modulus values calculated from backfill instrument readings .....	16
11. Measured and predicted vertical stress changes in pillars 102 and 103 .....	18

## UNIT OF MEASURE ABBREVIATIONS USED IN THIS REPORT

cm	centimeter	m <sup>2</sup>	square meter
cm <sup>2</sup>	square centimeter	MPa	megapascal
kg/m <sup>3</sup>	kilogram per cubic meter	pct	percent
km	kilometer	t/d	metric ton per day
m	meter		

Reference to specific products does not imply endorsement by the U.S. Bureau of Mines.

### Disclaimer of Liability

The U.S. Bureau of Mines expressly declares that there are no warranties expressed or implied that apply to the software described herein. By acceptance and use of said software, which is conveyed to the user without consideration by the Bureau of Mines, the user hereof expressly waives any and all claims for damage and/or suits for or by reason of personal injury, or property damage, including special, consequential, or other similar damages arising out of or in any way connected with the use of the software described herein.

# Stability Analysis of a Backfilled Room-and-Pillar Mine

By D. R. Tesarik,<sup>1</sup> J. B. Seymour,<sup>2</sup> T. R. Yanske,<sup>3</sup> and R. W. McKibbin<sup>2</sup>

---

## ABSTRACT

Displacement and stress changes in cemented backfill and ore pillars at the Buick Mine, near Boss, MO, were monitored by engineers from the U.S. Bureau of Mines and The Doe Run Co., St Louis, MO. A test area in this room-and-pillar mine was backfilled to provide support when remnant ore pillars were mined. Objectives of this research were to evaluate the effect of backfill on mine stability, observe backfill conditions during pillar removal, and calibrate a numeric model to be used to design other areas of the mine.

Relative vertical displacements in the backfill were measured with embedment strain gauges and vertical extensometers. Other types of instruments used were earth pressure cells (to identify loading trends in the backfill), borehole extensometers (to measure relative displacement changes in the mine roof and support pillars), and biaxial stressmeters (to measure stress changes in several support pillars and abutments).

Two- and three-dimensional numeric codes were used to model the study area. With information from these codes and the installed instruments, two failed pillars were identified and rock mass properties were estimated.

---

<sup>1</sup>Mechanical engineer, Spokane Research Center, U.S. Bureau of Mines, Spokane, WA.

<sup>2</sup>Mining engineer, Spokane Research Center.

<sup>3</sup>Mine engineer, The Doe Run Co., St. Louis, MO.

## INTRODUCTION

Historically in room-and-pillar mines in the United States, ore pillars have been left to support the mine roof. Although this mining method is structurally sound, it decreases the life of the mine because approximately 25 pct of the resource is not used. The Doe Run Co., St. Louis, MO, developed a method in which cemented backfill was used in mining pillars in a test section of its Buick Mine, near Boss, MO. Rock mechanics consulting services were supplied by Golder Associates, Burnaby, BC. To evaluate this mining method, engineers from the U.S. Bureau of Mines (USBM) and The Doe Run Co. installed instruments in the backfill and host rock to measure stress and displacement changes during pillar mining. The in situ stress state was measured in a barrier pillar next to the test area before mining was initiated in the pillars.

Foreign mines have been using backfill to achieve total ore extraction for a number of years. The Keretti Mine in Finland (Koskela, 1983) uses a modified room-and-pillar method and Mount Isa Mines, Ltd., Mount Isa, Australia, achieves total ore extraction using an open stoping method with backfill (Bloss and others, 1993). Cemented fill was introduced in the Canadian Sudbury mines in the early 1960's in cut-and-fill and

pillar recovery operations (Udd, 1989). Recently, the West Driefontein Mine, located approximately 60 km west of Johannesburg, South Africa, designed a modified room-and-pillar mining method to mine a reef dipping 25° to 30° (Stilwell, 1983).

Advances in backfilling in the United States have resulted in new mining methods for room-and-pillar or slot-and-pillar mines that recover nearly 100 pct of the ore deposit. The Cannon Mine, near Wenatchee, WA, uses an overhand bench-and-fill technique to mine 8-m-wide by 24-m-high by 45-m-long stope blocks (Brechtel and others, 1989a; Brechtel and others, 1989b; Tesarik and others, 1983; Tesarik and others, 1989). The American Girl Mine near Yuma, AZ, uses a similar method in a narrow, shallow-dipping ore body.<sup>4</sup>

Other than pillar robbing, complete recovery of previously developed room-and-pillar mines is limited in the United States. At the Magmont Mine near Bixby, MO, uncemented cycloned mill tailings were used to confine the bottom one-third of the pillars in a narrow section of the mine. The upper two-thirds of the pillars were extracted by retreat mining (Tesarik and McKibbin, 1989).

## BUICK MINE

The Doe Run Co.'s Buick Mine is located 195 km southwest of St. Louis, MO, in a deposit called the New Lead Belt or Viburnum Trend (figure 1). The mine produces lead, zinc, and copper ore using a room-and-pillar mining method at depths ranging from 335 to 366 m. The Buick ore body is 60 to 120 m wide with ore thicknesses ranging from 2.4 to 36.6 m. A generalized stratigraphic column is shown in figure 2. The mine is divided into two sections, the North Mine and the South Mine. The North Mine has the highest grade ore, but most of the developed reserves are existing support pillars in the South Mine.

### TEST AREA

The test area was approximately 107 by 69 m and contained 15 pillars with heights ranging from 14 to 19 m. The pillars were approximately 9 m per side with 9.8-m-wide rooms yielding an extraction ratio of 77 pct. Before the pillars were extracted, a fill fence was constructed around the perimeter of the pillars (figure 3). The steel-reinforced shotcrete fence was constructed sequentially, from the floor to the roof, as lifts of cemented rock fill were placed. In addition, 1.5-m<sup>2</sup> shotcreted cyclone fences were constructed from the floor to the roof on the north side of pillars 101, 102, 103, and 104. The inside of

these enclosures were not filled with backfill and served as blasting release areas (free faces) when the pillars were blasted.

Dolomite waste rock was quarried underground for use as aggregate in the backfill mix, crushed to minus 12 cm and mixed with about 4 pct cement at a portable batching plant. Backfill was transported from the batching plant to the test area by a conveyor, transferred throughout the test area with front-end loaders, and spread in 0.3- to 0.6-m lifts with a wheel dozer. Backfilling rates ranged from 1,000 to 2,000 t/d. The maximum aggregate diameter for the top 3-m lift was 5 cm and was placed with front-end loaders and slinger trucks. The gap left between the backfill and mine roof ranged from 0 to 2.0 cm and was less than 1.3 cm in most areas.

The pillar extraction sequence for the test area and for several pillars north and south of this area is listed in table 1. Pillars in the drift northeast of the test area were extracted prior to January 20, 1992, the date when the instrument system was functioning. Pillars 101 through 104, referred to as trapped pillars, were drilled, blasted, and mucked from a drift excavated beneath the test area.

<sup>4</sup>Paper presented at the 97th annual meeting of the Northwest Mining Association, Spokane, WA, entitled "American Girl Underground Mine" by R. K. Towner and J. W. Keifer, 1991, 12 pp.



Figure 1

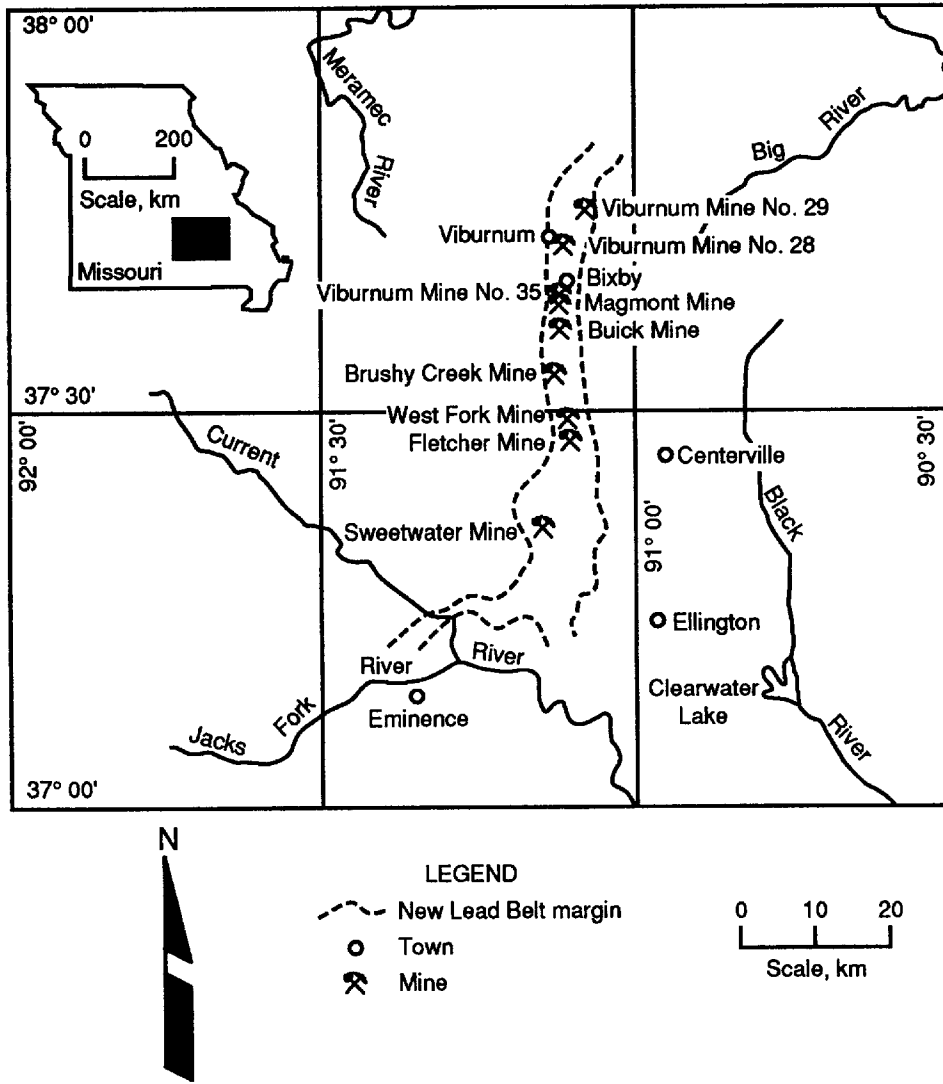

Location of New Lead Belt.

Table 1.—Pillar extraction sequence, days after January 20, 1992

Pillar	Days	Pillar	Days	Pillar	Days
97, east half	0	5, north half	123	111	212
96	17	113, bottom 12.5 m	123	110	212
87, south half	17	6, west 3.7 m	123	93	221
97, west half	17	113, top 4.3 m	127	92	233
95	52	5, south half	177	101	389
86, south half	52	14, north half	177	102, 7 holes	444
94	59	112	192	102, 20 holes	451
105	85	4, north half	192	104	515
106	85	4, south half	199	103	695
114	101	13, north half	199		

Figure 2

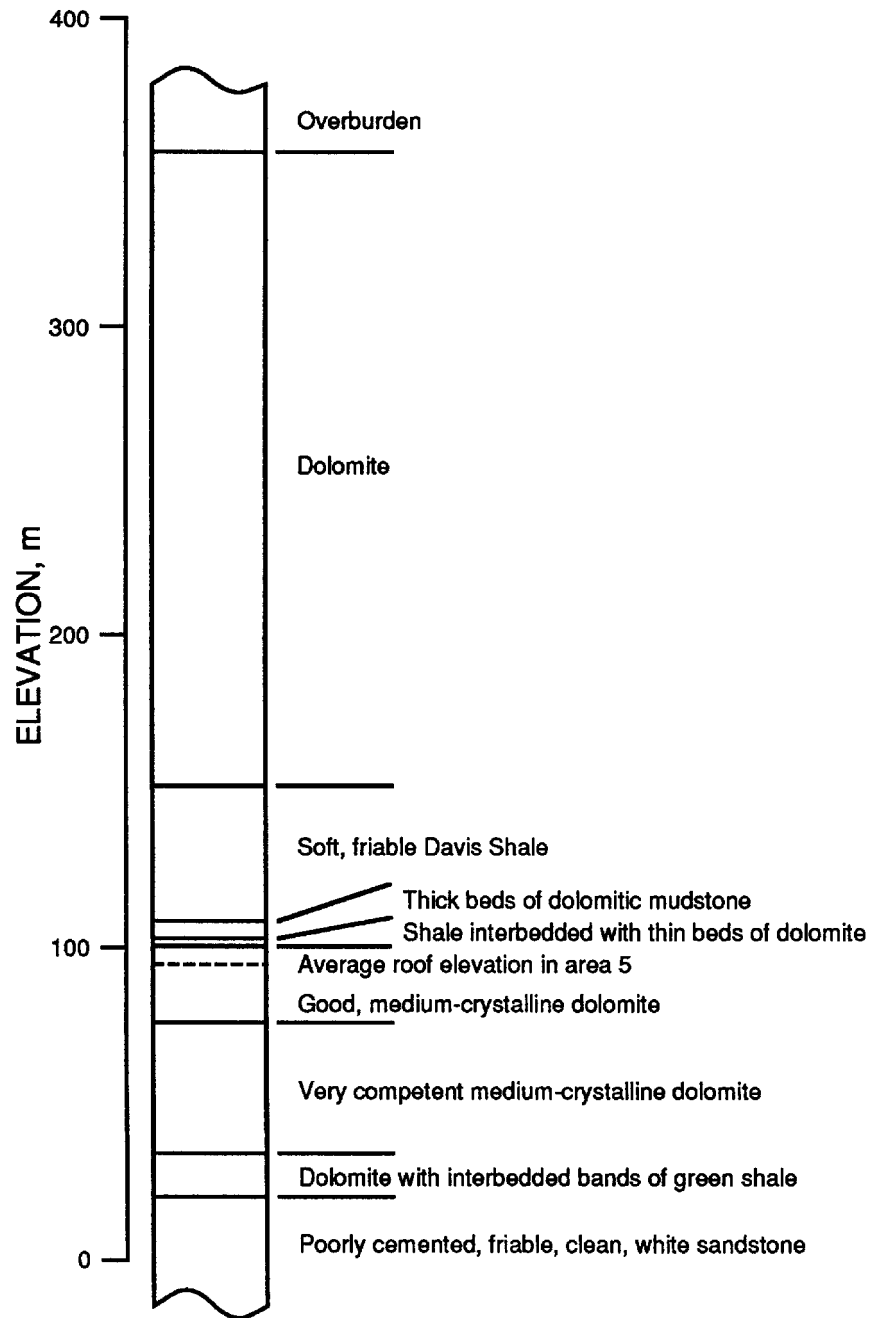

*Generalized stratigraphic column in area 5 (Courtesy of Buick Mine personnel).*

Figure 3

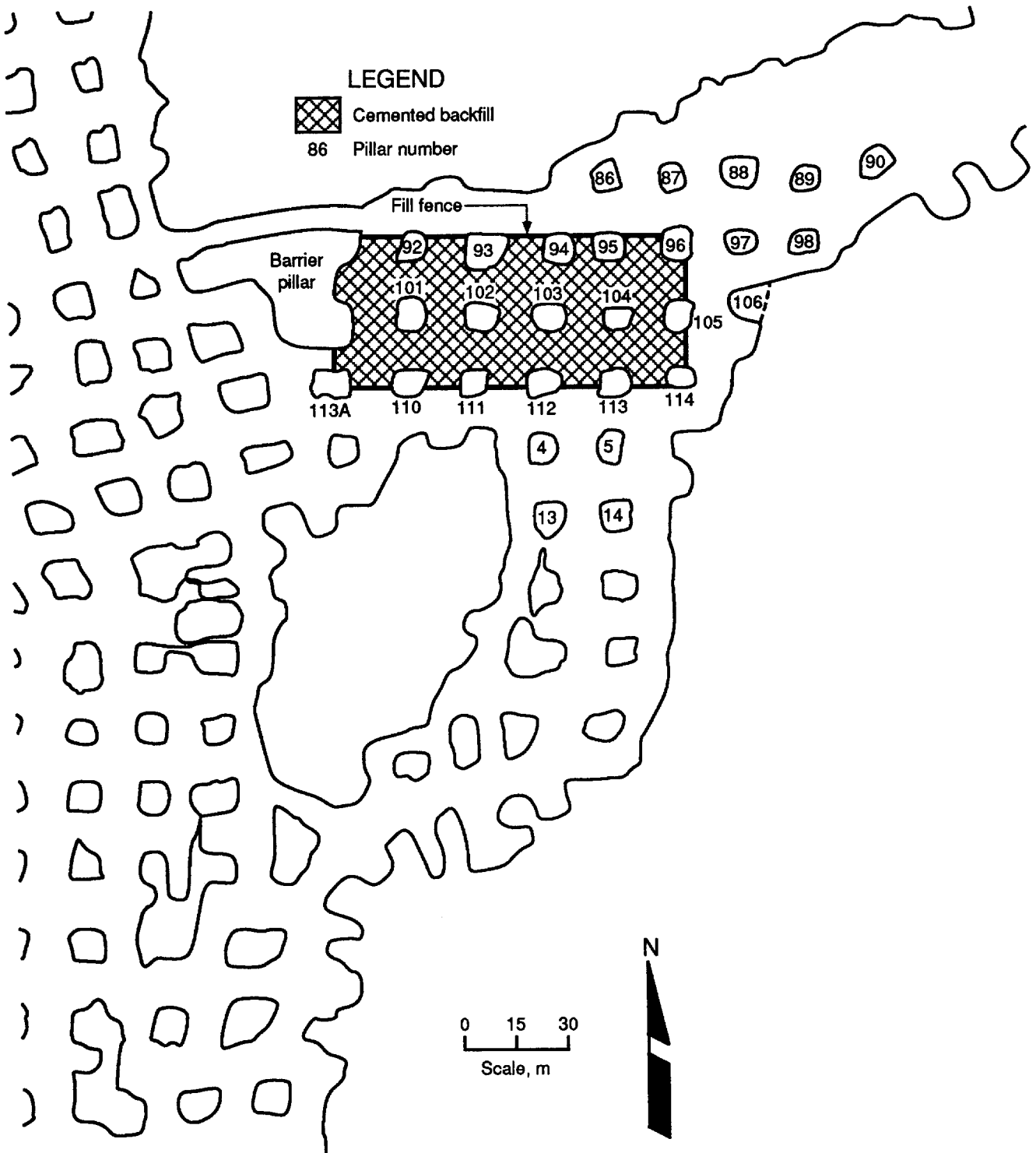

Plan view of area 5.

**INSTRUMENTS**

All the instruments installed in the backfill and support pillars in area 5 were manufactured by Geokon, Inc., Lebanon, NH. These instruments contained vibrating-wire sensors consisting of a tensioned steel wire and a coil and magnet assembly. When a pulse generated by a datalogger is sent along the instrument cable and applied to the coil, the wire vibrates at its resonant frequency. This frequency is induced in a pickup coil and transmitted back to the datalogger for processing and/or storage. Because strain in the wire is directly proportional to gauge frequency, linear calibration equations for instruments containing these sensors can be used to relate frequency readings to displacement or pressure changes.

Three Campbell Scientific dataloggers were used to monitor all the instruments in this study (figures 4-5). In addition,

the dataloggers collected data from three Commonwealth Scientific and Industrial Organization (CSIRO) hollow inclusion cells, a Yoke gauge, a USBM deformation gauge, and two biaxial stressmeters. These instruments were installed in the barrier pillar to monitor long-term stress changes. Instrument readings were taken automatically every 2 hours by the dataloggers, but this time interval was reduced to several minutes before and after some blasts.

Cables were strung from the instruments to the dataloggers through steel pipes placed in the backfill. A slot cut with a cutting torch along the pipe's longitudinal axis facilitated cable placement in the pipe. These pipes were covered with used vent bag material to keep rock fill out of the slots. A larger diameter pipe cut in half served as a protective cover for the cable at the open joints between the slotted pipes. Backfill was placed to a depth of about 0.5m over the pipes and

*Figure 4*

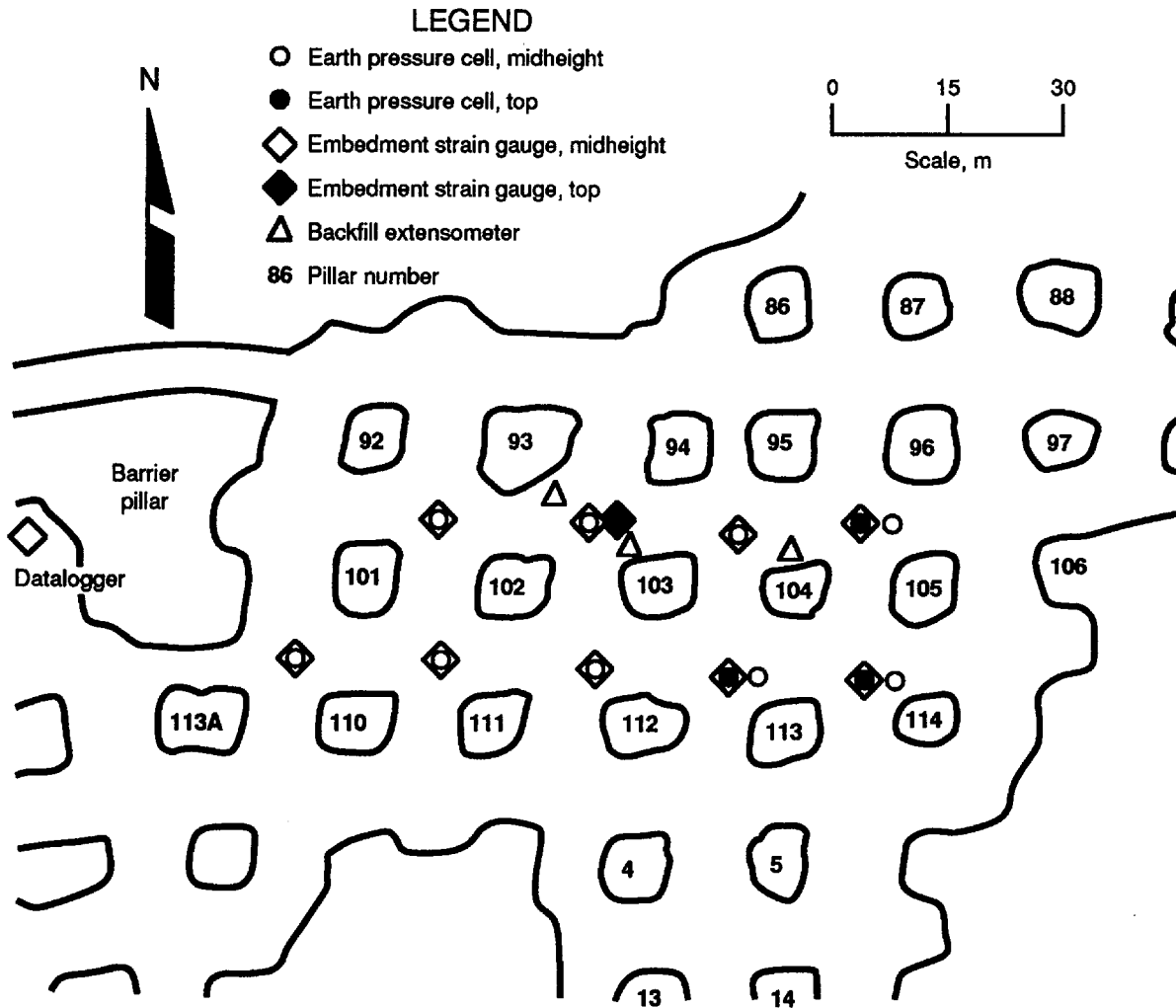

*Location of instruments installed in backfill.*

and was left to cure for 1 day before heavy machinery was driven over it.

Earth pressure cells, embedment strain gauges, and vertical extensometers were placed in the cemented backfill (figure 4) to identify loading patterns and to measure relative displacement changes when the rock pillars were extracted. Most of the earth pressure cells and embedment strain gauges were installed when the test area was backfilled to midheight (9 m). Some of these instruments were placed near the top of the backfill, 1 to 2 m below the roof, under vertical borehole extensometers in the rock. The purpose of using these instruments was to identify when the backfill began to load.

The embedment strain gauges are 25.4 cm long with 5.1-cm-diam steel flanges at each end. A steel wire-and-spring assembly is tensioned between the flanges in 2.54-cm-diam steel tubing and provides up to 0.64 cm of relative displacement. Prior to installation, the gauges were precast in wood forms using cemented backfill mix with minus

0.64-cm aggregate. This facilitated vertical alignment during installation and provided protection when the wet backfill was first placed over the gauge.

Earth pressure cells having a maximum load capacity of 6.9 MPa were used to identify loading trends and were not relied upon for precise measurements. The 22.9-cm-diam instruments were precast in a form slightly larger than the cell using the same backfill mix that was used to cast the embedment strain gauges. This form was removed before the instrument was placed in the stope.

Three vertical extensometers were constructed to measure relative displacement in the cemented backfill. The distance between anchors for these instruments ranged from 4.2 to 16.5 m (figure 6) and the top anchor of all three instruments was positioned approximately 4.5 m below the mine roof. A 5-cm steel pipe coupler was welded to a plate that served as the bottom anchor for these instruments. Sections of steel pipe were threaded together with couplers as the backfill height

*Figure 5*

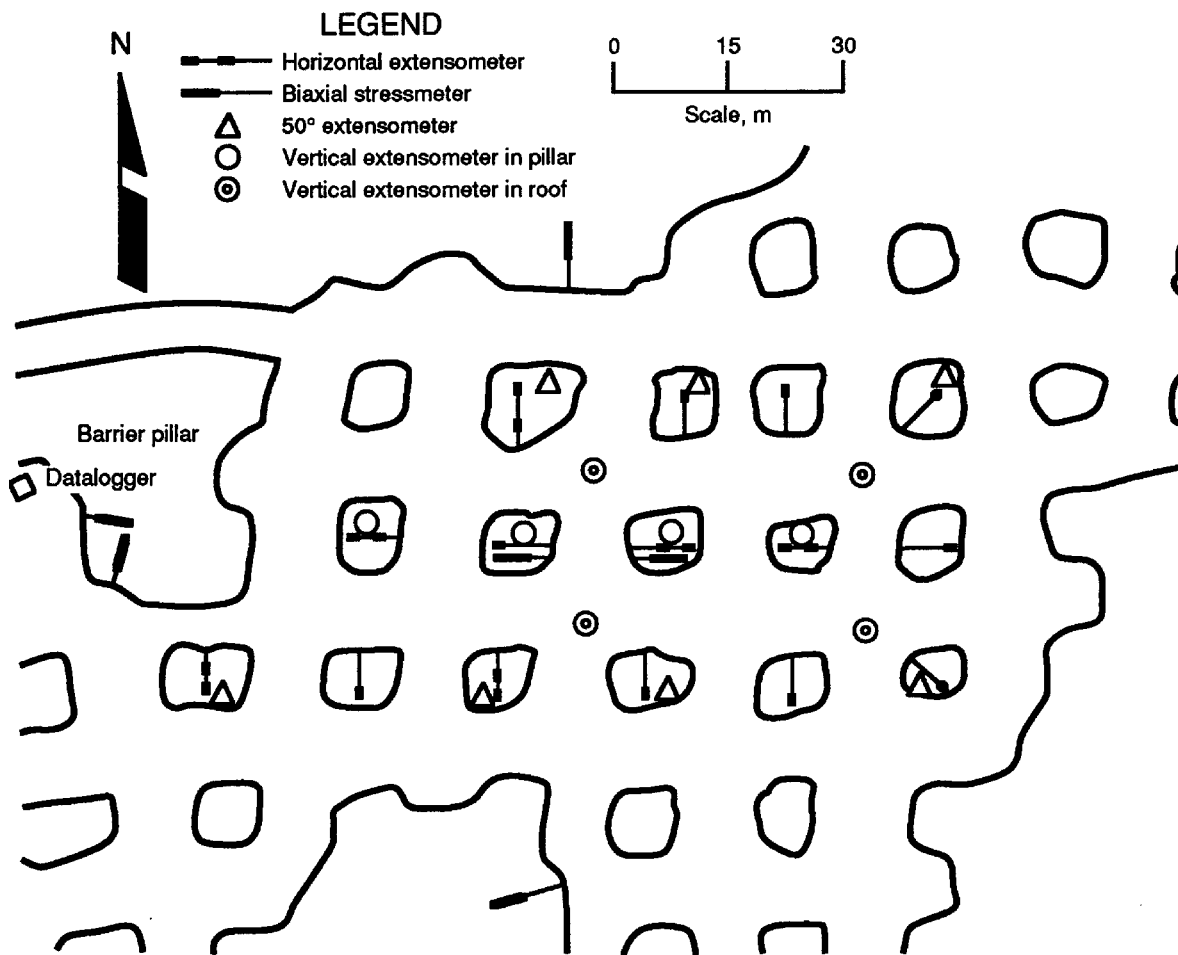

*Location of instruments installed in rock.*

Figure 6

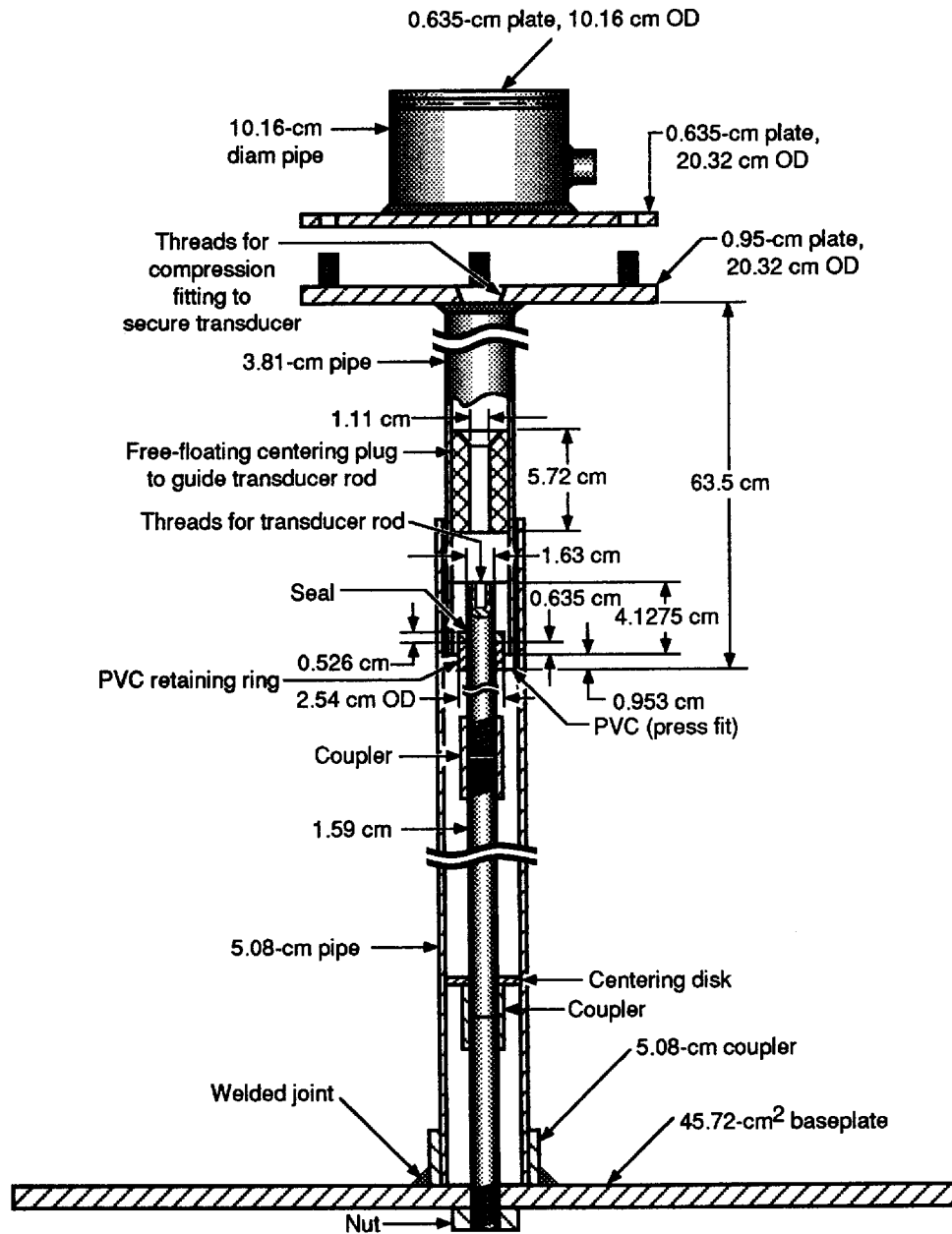

Vertical backfill extensometer.

increased. Similarly, sections of steel rod were coupled inside the pipe to connect the bottom anchor plate to the top anchor and transducer housing. The protective steel pipe was greased during construction to help reduce friction between the pipe wall and the cured backfill. An aluminum extension rod screwed into the top of the transducer was used to thread the transducer rod into a tapped hole in the last section of steel rod. The transducer rod was pulled up approximately 9 cm to account for expected backfill compression and was secured to the top anchor with a compression fitting. A steel cover was bolted to the top anchor to protect the extension rod, compression fitting, and transducer wires. The lengths and locations of these instruments are listed in table 2.

Borehole extensometers and biaxial stressmeters were installed in test area pillars, the mine roof, and the north

and south abutments to monitor stress changes and relative displacements (figure 5). The angled extensometers were placed in boreholes having dip angles from 45° to 69° with the hole collar positioned approximately 3 m from the floor. The horizontal extensometers were located at midheight on the pillars, at the same elevation as most of the backfill instruments. The vertical extensometers were installed from an access drift 3 to 7 m beneath the test area (figure 7). The collar anchors for these instruments were placed in the roof of the access drift, and the two uphole anchors were placed approximately at the top and bottom of the trapped pillars. The location, borehole dip, and anchor depths for the instruments installed in rock are also shown in table 2.

Table 2.—Instrument location

Location	Instrument	Dip, <sup>1</sup> d <sup>eg</sup>	Distance from collar or base, m	
			Anchor No. 1	Anchor No. 2
Southeast of pillar 93	VBX <sup>2</sup>	90	16.46	
Northwest of pillar 103	VBX	90	11.89	
North of pillar 104	VBX	90	4.18	
Pillar 93	BX <sup>3</sup>	0	4.57	8.84
Pillar 93	BX	45	7.62	14.63
Pillar 94	BX	0		7.92
Pillar 94	BX	52	8.08	14.94
Pillar 95	BX	0	6.71	
Pillar 96	BX	0	9.14	
Pillar 96	BX	49	8.38	16.76
Pillar 101	BX	0	3.81	5.05
Pillar 101	BX	90	7.01	24.08
Pillar 102	BX	0	7.62	
Pillar 102	BX	90	3.66	24.69
Pillar 102	SM <sup>4</sup>	-5	6.49	
Pillar 103	BX	0	4.72	7.92
Pillar 103	BX	90	5.13	26.82
Pillar 103	SM	-5	4.62	
Pillar 104	BX	0	3.73	6.10
Pillar 104	BX	90	4.88	26.21
Pillar 113A	BX	0	4.39	7.24
Pillar 113A	BX	52	5.79	10.97
Pillar 110	BX	0	2.74	
Pillar 111	BX	0	3.15	4.78
Pillar 111	BX	58	6.40	12.50
Pillar 112	BX	0	3.66	
Pillar 112	BX	69	6.86	13.11
Pillar 113	BX	0	3.96	
Pillar 114	BX	0	4.11	6.71
Pillar 114	BX	56	7.77	14.33
Centered on 93, 94, 102, 103	BX	90	11.18	
Centered on 95, 96, 104, 105	BX	90	10.87	
Centered on 102, 103, 111, 112	BX	90	11.18	
Centered on 104, 105, 113, 114	BX	90	11.18	
North abutment	SM	-5	6.12	
South abutment	SM	-5	3.54	
Barrier pillar, west face	SM	-3	6.10	
Barrier pillar, south face	SM	-3	6.10	

<sup>1</sup>Dip Angle up from the horizontal (positive).

<sup>2</sup>VBX Vertical backfill extensometer.

<sup>3</sup>BX Borehole extensometer.

<sup>4</sup>SM Biaxial stressmeter.

NOTE.—Blank spaces indicate no data were collected.

Figure 7

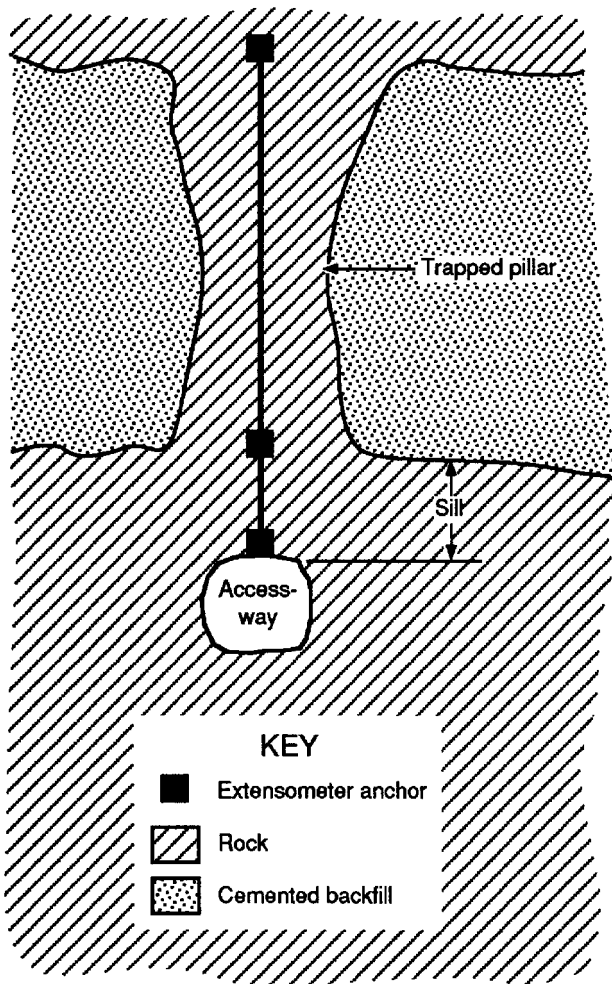

**Vertical section through trapped pillar showing two-point vertical extensometer installed from lower access drift.**

The borehole extensometers were installed in B-size diamond boreholes with an enlarged collar that allowed the transducer heads to be recessed from the face, protecting them from fill rock. By inflating copper bladder anchors with hydraulic oil to a pressure of 9.5 MPa, the instruments were secured in the borehole. Fiberglass rods connected the downhole anchors to transducers at the collar anchor.

Biaxial stressmeters measure radial deformation of a borehole with three-wire sensors extended across the diameter of a steel cylinder. These wires are oriented 0°, 60°, and 120°

from vertical. Secondary principal stress change and direction can be calculated using the frequency change in each of these wires. The stressmeter can be equipped with an extra set of radial sensors for backup measurements and a temperature and longitudinal sensor for more accuracy.

To install a stressmeter, a high-strength, nonshrinking grout is first pumped into the bottom of a slightly downward-dipping borehole. With an installation rod equipped with a leveling device at the collar end, the stressmeter is pushed down the hole into the grout. After the level is used to orient one of the wire sensors vertically, a cable-activated pin is pulled to release a snap-ring anchor. The snap ring holds the stressmeter at the correct orientation while the setting rods are removed and more grout is pumped into the hole. Some of the grout is poured into cylindrical molds, cured at 100-pct humidity for 28 days, and tested for unconfined compressive strength. The average strength of the grout for this work was 44 MPa and the average value for modulus of deformation was 15,400 MPa.

**STRESS DETERMINATION BEFORE PILLAR REMOVAL**

Three-dimensional stress was measured in the barrier pillar before pillars were mined in the test area. Both CSIRO hollow inclusion cells and USBM borehole deformation gauges were used. These gauges were set and overcored at depths between 3.3 and 6.7 m down four boreholes for a total of five measurement sets. Principal stresses and stress components are shown in tables 3 and 4.

**Table 3.—Measured in situ principal stresses**

Stress, MPa <sup>1</sup>	Azimuth, deg <sup>2</sup>	Dip, deg <sup>3</sup>
-12.48	-236.1	-76.9
-6.55	-226.8	12.9
-2.76	-317.2	2.0

<sup>1</sup>Minus sign indicates compressive stress.

<sup>2</sup>Azimuth Angle clockwise from north (positive).

<sup>3</sup>Dip Angle up from horizontal (positive).

**Table 4.—Measured in situ stress components**

Type of stress	Direction	Amount, MPa
Normal	North-south	-4.60
Normal	East-west	-5.01
Normal	Vertical	-12.18
Shear	North-south, east-west	-2.03
Shear	East-west, vertical	1.18
Shear	Vertical, north-south	0.63

Note.—Minus sign indicates compressive stress.



**MATERIAL PROPERTY DETERMINATION**

BX-size (4.13-cm) core samples from the barrier pillar, test area pillars, and north abutment were used for material property tests. The length of each specimen prepared for unconfined compression tests had a 2:1 length-to-width ratio, and the ends were ground to meet American Society for Testing Materials (ASTM) standards for parallelism. Strain gauges were glued laterally and longitudinally on each specimen to determine Poisson's ratio. Specimens having a thickness of approximately 2.54 cm were also prepared from the rock core for Brazilian tensile tests. Average values from 24 unconfined compression tests and 23 Brazilian tensile tests are listed in table 5. The data have been separated into two categories based on a specific gravity value of 2.76. Specimens having a specific gravity less than or equal to this value are categorized as waste rock, and specimens having a specific gravity greater than this value are categorized as ore. All but one specimen categorized as ore were obtained from test area pillars that were eventually mined.

**Table 5.—Material properties of host rock determined from laboratory tests**

	Young's modulus, MPa	Unconfined compressive strength, MPa	Tensile strength, MPa	Specific weight, kg/m <sup>3</sup>	Poisson's ratio
Waste rock . .	87,940	140	11.3	2,611	0.26
Ore . . . . .	80,550	109	9.0	4,709	0.24

**NUMERIC MODELS**

The three-dimensional, boundary-element program BESOL (Crouch Research, Inc., 1986) was used to model backfilling and pillar extraction in area 5. The modeled area in plan view represented a 275- by 275-m section of the mine with area 5 near the center. The modeled area was divided into square elements that represented 1.5 m of rock on each side. The pillar height was assumed to be 18.3 m with an overburden thickness of 366 m.

Initial vertical stresses in the model were calculated using 2,307 kg/m<sup>3</sup> as the density of the overburden. Initial shear stresses were assumed to be zero. Initial horizontal stresses were calculated using equation 1, because in situ information on these stresses was not available. The effect of a large initial horizontal stress field on pillar stresses and factors of safety is discussed in Tesarik and others (1989).

$$\sigma_{xx} = \sigma_{yy} = \left( \frac{\nu}{1-\nu} \right) \sigma_{zz}, \tag{1}$$

where  $\sigma_{xx}$  = normal stress component in the x (horizontal) direction, MPa,

$\sigma_{yy}$  = normal stress component in the y (horizontal) direction, MPa,

$\nu$  = Poisson's ratio,

and  $\sigma_{zz}$  = normal stress component in the z (vertical) direction, MPa.

The predicted vertical stress in the barrier pillar before support pillars were extracted ranged from -11.6 to -23.4 MPa. The predicted vertical stress at the location of the in situ stress measurements was -12.6 MPa. This value contrasted to the measured vertical stress value of -12.2 MPa, indicating that gravity loading with an overburden density of 2,307 kg/m<sup>3</sup> was a reasonable assumption.

All materials were assumed to be isotropic and linearly elastic and are listed in table 6.

**Table 6.—Material properties used in program BESOL**

Modulus of elasticity, rock mass, <sup>1</sup> MPa . . . . .	17,240
Modulus of elasticity, pillars, MPa . . . . .	84,830
Modulus of elasticity, backfill, MPa . . . . .	790
Poisson's ratio, rock mass . . . . .	0.25
Poisson's ratio, pillars . . . . .	0.26

<sup>1</sup>All material excluding the material in the mining horizon.

The relatively low modulus value for the rock mass represents the dolomitic mudstone and Davis Shale layers (Farmer, 1968) that are deposited above the competent dolomite seam. The modulus of elasticity for the pillars was obtained from unconfined compressive tests and the modulus of elasticity for the backfill was based on in situ measurements in cemented backfill of similar composition at the Cannon Mine (Tesarik and others, 1983).

To determine the modulus for the pillar rock mass, strains calculated from measured displacements in the trapped pillars were plotted against model-predicted strains (figure 8). Data collected after the pillar 5 blast were not used in this plot because predicted strain changes in pillars 102 and 103 were 1.3 and 6.6 times larger than measured strain changes, indicating that possibly these pillars were no longer behaving elastically. A line was fit to the data using regression analysis.

Figure 8

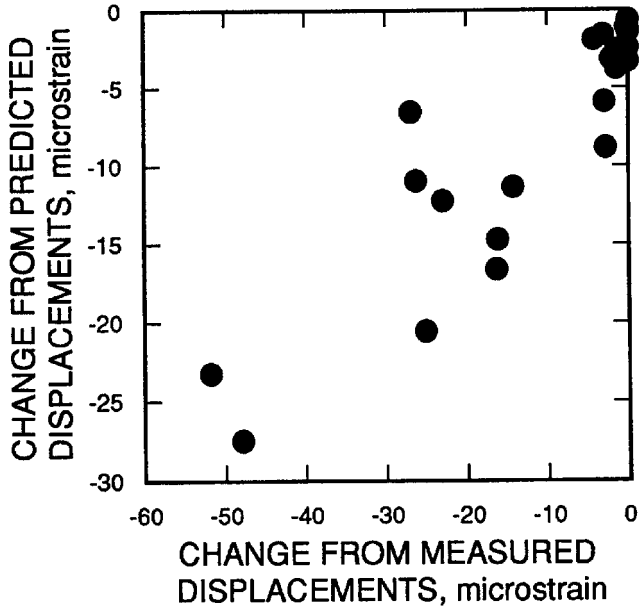

*Microstrain changes in trapped pillars calculated from measured and predicted displacements.*

The slope of the line was 0.45, and the correlation coefficient for the data was 0.9. An adjusted rock mass modulus was calculated using equations 2 through 5.

$$\frac{\Delta \epsilon_{\text{Predicted}}}{\Delta \epsilon_{\text{Measured}}} = 0.45. \quad (2)$$

For predicted and measured stresses to be equal,

$$\epsilon_{\text{Predicted}} E_{\text{Predicted}} = \epsilon_{\text{Measured}} E_{\text{Measured}} \quad (3)$$

and

$$\frac{\epsilon_{\text{Predicted}}}{\epsilon_{\text{Measured}}} E_{\text{Predicted}} = E_{\text{Measured}}. \quad (4)$$

Thus, the adjusted modulus is

$$E_{\text{Adjusted}} = .45 E_{\text{Predicted}} = 38,170 \text{ MPa}. \quad (5)$$

Regression analysis for measured stress changes in the backfill and stress changes predicted by BESOL resulted in a correlation coefficient equal to 0.52. The maximum predicted stress in the backfill at the locations of the earth pressure cells

was 1.6 MPa. This backfill stress was predicted between pillars 94, 95, 103, and 104. With an adjusted pillar modulus of 38,170 MPa, the maximum predicted backfill stress did not increase.

A north-south cross section of area 5 was modeled using the two-dimensional, finite-element program UTAH2.<sup>5</sup> For this model, it was assumed that there were three rows of pillars with abutments north and south of the backfilled area. The modeling sequence consisted of mining the crosscuts, backfilling these crosscuts, mining pillars 92 through 96, and mining pillars 110 through 113. To account for three-dimensional mine geometry, overburden weight was increased to 4,819 kg/m<sup>3</sup> using equation 6 (Pariseau, 1979).

$$\begin{aligned} \gamma_{2D} &= \gamma \left( 1 + \frac{W_c}{L_p} \right) \\ &= 2,307 \text{ kg/m}^3 \left( 1 + \frac{9.8 \text{ m}}{9 \text{ m}} \right) = 4,819 \text{ kg/m}^3, \quad (6) \end{aligned}$$

where  $\gamma_{2D}$  = adjusted specific weight of overburden used in the two-dimensional analysis, kg/m<sup>3</sup>,

$\gamma$  = specific weight of overburden used to develop the initial in situ stress state, kg/m<sup>3</sup>,

$W_c$  = crosscut width, m,

and  $L_p$  = pillar side length, m.

The ANSYS (DeSalvo and Gorman, 1989) preprocessor was used to define mine geometry and automatically mesh the cross section into 8,260 elements. Elements representing the pillars and the backfill had a length and width of approximately 1.5 m, and elements at the rock-backfill interface had a width of 0.3 m. Assigning weak material properties to these elements allowed them to deform plastically in a vertical direction and allowed the modeled backfill to develop self-loading stresses. The mesh represented overburden up to and including the mine's surface, and the side and lower boundaries represented a distance approximately two times the width of the backfilled area.

An elastic, perfectly plastic model was used for all materials. The yield criterion used was Drucker-Prager, where strength depends on all three principal stresses, and associated flow rules were applied to determine strains in the yielded elements.

<sup>5</sup>OFR 47(2)-80. Interpretation of Rock Mechanics Data: A Guide to Using UTAH2 by W. G. Pariseau.

The same stratigraphic layers as shown in figure 2 were used in the model, but it was assumed that dolomite, crystalline dolomite, and dolomite with shale had the same material properties. The layer having shale interbedded with thin beds of dolomite was given the same material property values as the Davis Shale stratum. The values for modulus of deformation, unconfined compressive strength, and tensile strength for the dolomite were determined in the laboratory tests described above. Properties for other rock types and overburden material were based on published values (Farmer, 1968; Sowers, 1979), and cemented backfill properties were obtained from laboratory tests. Laboratory and estimated material property values are given in table 7.

UTAH2 was calibrated by reducing the modulus of deformation values of all rock types to 45 pct of their laboratory values based on results from BESOL. The strengths of these materials were also reduced until plastic zones developed in pillar 103. The adjusted, unconfined compressive strength for the dolomite using this method was 38.2 MPa.

## INSTRUMENT RESPONSE TO MINING

In general, the earth pressure cells recorded compressive stress increases after each pillar blast, followed by stress relief that lasted until the next blast (figures 9-10). This decrease in stress was possibly caused by lateral movement of the backfill at the fill fence. As shown in table 8, readings from the earth pressure cells indicated that the maximum and average stresses after installation were only -0.98 and -0.41 MPa, respectively. The calculated weights of the backfill on the cells positioned 9.1 and 16.8 m from the floor are approximately -0.19 MPa and -0.032 MPa, respectively. When these values are subtracted from the total stress values, then the maximum and average stresses caused by mining are -0.79 and -0.28 MPa. Several instruments recorded total stress changes smaller than the stress calculated using only the weight of the backfill. The smaller measurement could be caused by resistance of the fill to shear along vertical planes at the rock-backfill interface (Bloss and others, 1993).

**Table 7.—Laboratory and estimated material properties for UTAH2 analysis**

Material	Elastic modulus, MPa	Uniaxial compressive strength, MPa	Tensile strength, MPa	Poisson's ratio	Density, kg/m <sup>3</sup>
Dolomite . . . . .	84,830	127.4	9.8	0.26	3,492
Dolomitic mudstone . . . . .	34,483	53.8	5.4	0.25	3,492
Davis Shale . . . . .	17,241	53.8	5.4	0.25	2,195
Sandstone . . . . .	41,690	93.1	6.4	0.25	2,307
Overburden . . . . .	19	0.7	0.03	0.30	2,082
Cemented backfill . . . . .	3,793	8.3	2.1	0.30	2,114

**Table 8.—Maximum compressive stresses recorded by earth pressure cells after installation, megapascals**

Cell location	Distance from floor, m	Stress change	
		Total	Minus backfill weight
92, 93, 101, 102 <sup>1</sup> . . . . .	9.1	<sup>2</sup> -0.08	0.00
93, 94, 102, 103 . . . . .	9.1	-0.30	-0.11
94, 95, 103, 104 . . . . .	9.1	-0.29	-0.10
95, 96, 104, 105 . . . . .	9.1	-0.66	-0.47
95, 96, 104, 105 . . . . .	16.8	-0.36	-0.33
101, 113A, 110 . . . . .	9.1	-0.28	-0.09
101, 102, 110, 111 . . . . .	9.1	-0.98	-0.79
102, 103, 111, 112 . . . . .	9.1	-0.71	-0.52
103, 104, 112, 113 . . . . .	16.8	-0.28	-0.25
103, 104, 112, 113 . . . . .	9.1	-0.13	-0.00
104, 105, 113, 114 . . . . .	16.8	-0.42	-0.39
104, 105, 113, 114 . . . . .	9.1	-0.44	-0.25
Average . . . . .		-0.41	-0.28

<sup>1</sup>Gauge centered on pillar<sup>s</sup> 92, 93, 101, and 102.

<sup>2</sup>Minus sign indicates compressive stress.

Figure 9

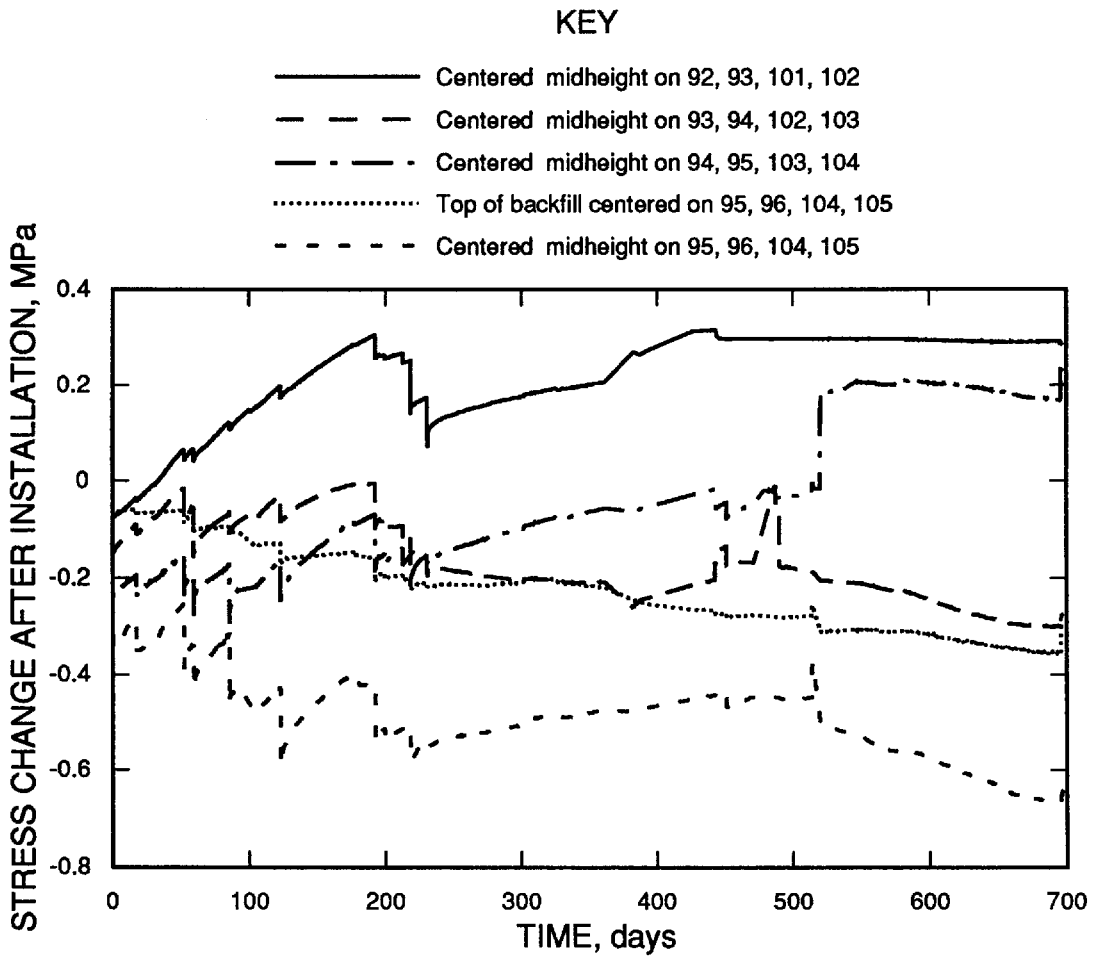

*Stress changes recorded by earth pressure cells in north section of area 5.*

The maximum measured backfill stress is less than the average unconfined compressive strength of Buick Mine backfill specimens composed of 17.7 pct cycloned tailings, 71-pct minus 7.6-cm crushed rock, and 2.7 pct cement. This backfill mix had an unconfined compressive strength of -1.39 MPa, indicating that the backfill remained in the elastic state.

A similar loading and unloading pattern was recorded by most of the embedment strain gauges. This pattern is illustrated in figure 11 using data from the embedment strain gauges installed midheight on pillars 102, 103, 111, and 112. Maximum compressive strains recorded after these instruments were installed are listed in table 9.

**Table 9.—Maximum microstrain recorded by embedment strain gauges after installation**

Cell location	Distance from floor, m	Microstrain change
92, 93, 101, 102 <sup>1</sup> ·····	9.1	<sup>2</sup> -287
93, 94, 102, 103 ·····	9.1	-201
93, 94, 102, 103 ·····	16.8	-168
94, 95, 103, 104 ·····	9.1	-308
95, 96, 104, 105 ·····	9.1	0
101, 113A, 110 ·····	9.1	-165
101, 102, 110, 111 ·····	9.1	-345
102, 103, 111, 112 ·····	9.1	-1,087
103, 104, 112, 113 ·····	9.1	-4,119

<sup>1</sup>Gauge centered on pillar<sup>s</sup> 92, 93, 101, and 102.

<sup>2</sup>Minus sign indicates compressive strain.

Figure 10

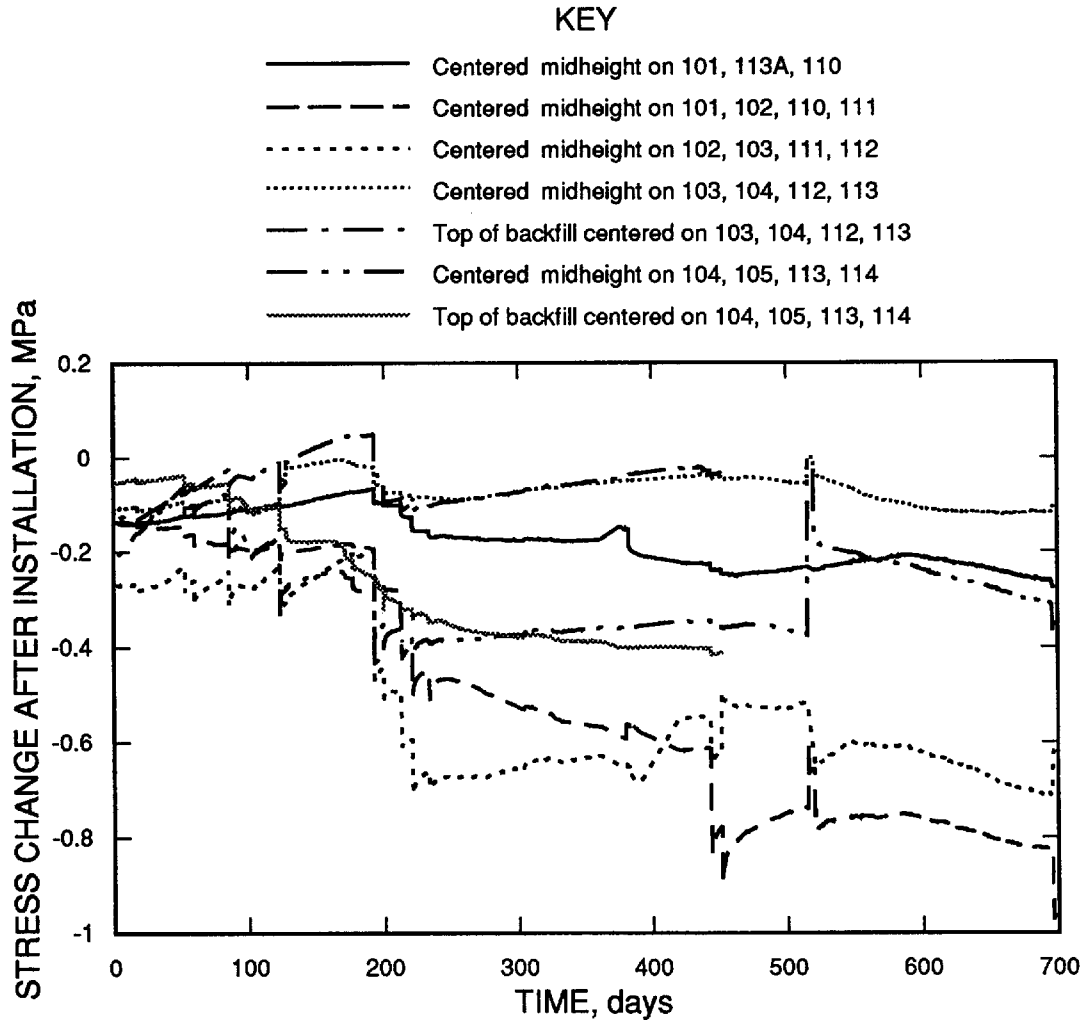

*Stress changes recorded by earth pressure cells in south section of area 5.*

After 250 days, strains measured by vertical fill extensometers exceeded strains recorded by embedment strain gauges in the same area (figure 12). This difference could have occurred because the top bearing plates for all the fill extensometers were positioned approximately 4.5 m below the mine roof, and backfill strains are likely to be larger at the top, rather than at midheight, of the fill. (Two of the three embedment strain gauges were installed midheight in the backfill.) Maximum strain values for all the instruments in the north section of area 5 were of the same order of magnitude, ranging from approximately  $-0.00015$  to  $-0.000375$ .

Estimated values of elastic moduli for the cemented backfill were calculated from pressure cells and embedment strain gauges or fill extensometers installed in the backfill

(table 10). Total stress at each measurement site was obtained by adding compressive stress increases recorded by an earth pressure cell after every pillar blast. This value was divided by the total compressive strain recorded by the closest embedment strain gauge or backfill extensometer. Based on measurements in backfill with aggregate and 6-pct cement, (Brechtel and others, 1989b) the values exceeding 6,900 MPa were not representative of in situ conditions. The average elastic modulus without these two values is 1,913 MPa.

The vertical extensometers in the trapped pillars recorded compressive strain after most blasts. This response was usually followed by time-dependent strain until the next pillar was removed. Figure 13 plots strain between downhole anchors caused by pillar removal, starting with pillar 96 on day 17.

Figure 11

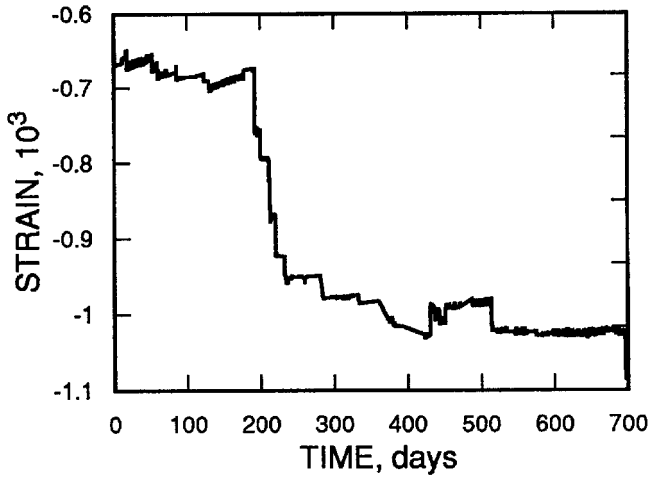

Strain measured by embedment strain gauge at midheight in backfill and centered on pillars 102, 103, 111, and 112.

Predicted pillar strains from BESOL using an elastic modulus of 38,170 MPa for the pillars are also shown.

Table 10.—Elastic modulus values calculated from backfill instrument readings, megapascals

Cell location	Strain instrument	Elastic modulus
92, 93, 101, 102 <sup>1</sup> . . . . .	ESG	2,690
93, 94, 102, 103 . . . . .	ESG	7,000
93, 94, 102, 103 . . . . .	16.5-m VBX	1,350
93, 94, 102, 103 . . . . .	11.9-m VBX	710
94, 95, 103, 104 . . . . .	ESG	4,160
94, 95, 103, 104 . . . . .	4.2-m VBX	2,550
95, 96, 104, 105 . . . . .	ESG	9,240
102, 103, 111, 112 . . . . .	ESG	2,320
103, 104, 112, 113 . . . . .	ESG	1,160
104, 105, 113, 114 . . . . .	ESG	360

ESG Embedment strain gauge.  
 VBX Vertical backfill extensometer.  
<sup>1</sup>Gauge centered on pillars 92, 93, 101, and 102.

Figure 12

KEY

- Embedment strain gauge centered on pillars 93, 94, 102, 103; mid height in backfill
- - - Embedment strain gauge centered on pillars 93, 94, 102, 103; top of backfill
- - - - Embedment strain gauge centered on pillars 94, 95, 103, 104; mid height in backfill
- 16.5-m vertical fill extensometer, southeast corner of pillar 93
- - - 11.9-m vertical fill extensometer, northwest corner of pillar 103
- · · · · 4.2-m vertical fill extensometer, north of pillar 104

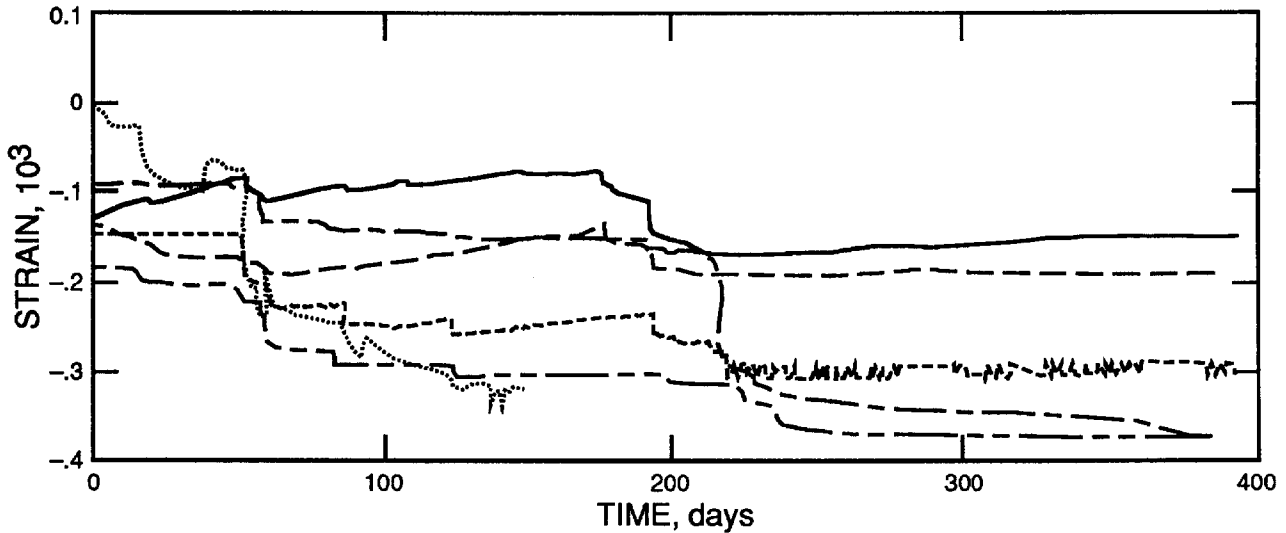

Strains measured by embedment strain gauges and vertical extensometers.

The plots for pillars 103 and 104 indicate that these pillars became inelastic after pillar 112 was blasted on day 192. The measured strain in pillar 103 on this day was about nine times greater than the predicted strain. After day 192, the measured strain rate increased with time, but there was little response to subsequent blasts, a result that was contrary to predicted strain behavior. A further indication that pillar 103 became plastic is that the drill steel stuck when the blast holes were drilled. Similar strain behavior was recorded by the extensometer in pillar 104, but the measured and predicted strains caused by the removal of pillar 112 were nearly equal.

In general, the horizontal extensometers in the trapped pillars recorded elastic tensional strains after most blasts, followed by time-dependent tensional strains (figure 14). Unlike the vertical extensometers in the pillars, data from these instruments did not clearly indicate when a pillar failed. Failure strain calculated from a tensile strength value of 11.3 MPa and elastic modulus value of 38,170 MPa is 0.0003. Strains in pillars 103 and 104 exceeded this value before day

100, well before estimated failure on day 192, which had been based on vertical extensometer readings and numeric model results. However, the strain rate in these pillars increased significantly after day 192, helping to confirm that the pillars became plastic at that time.

On the basis of horizontal strains calculated from downhole anchors and predicted strains calculated by BESOL, there were no indications of perimeter pillar failures. Strains from BESOL were added to measured strains to account for excavation of the entries and crosscuts, which took place before the extensometers were installed. The maximum measured internal horizontal strain was 0.00014 in pillar 111. If an additional horizontal strain value of  $4.6 \times 10^{-7}$  estimated from BESOL results is added to the measured value, the total horizontal strain is still less than the estimated failure strain of 0.00026. Similarly, the largest measured internal vertical strain added to the predicted strain caused by removal of entries and crosscuts was -0.000083. The average compressive failure strain of laboratory specimens was -0.000145.

**Figure 13**

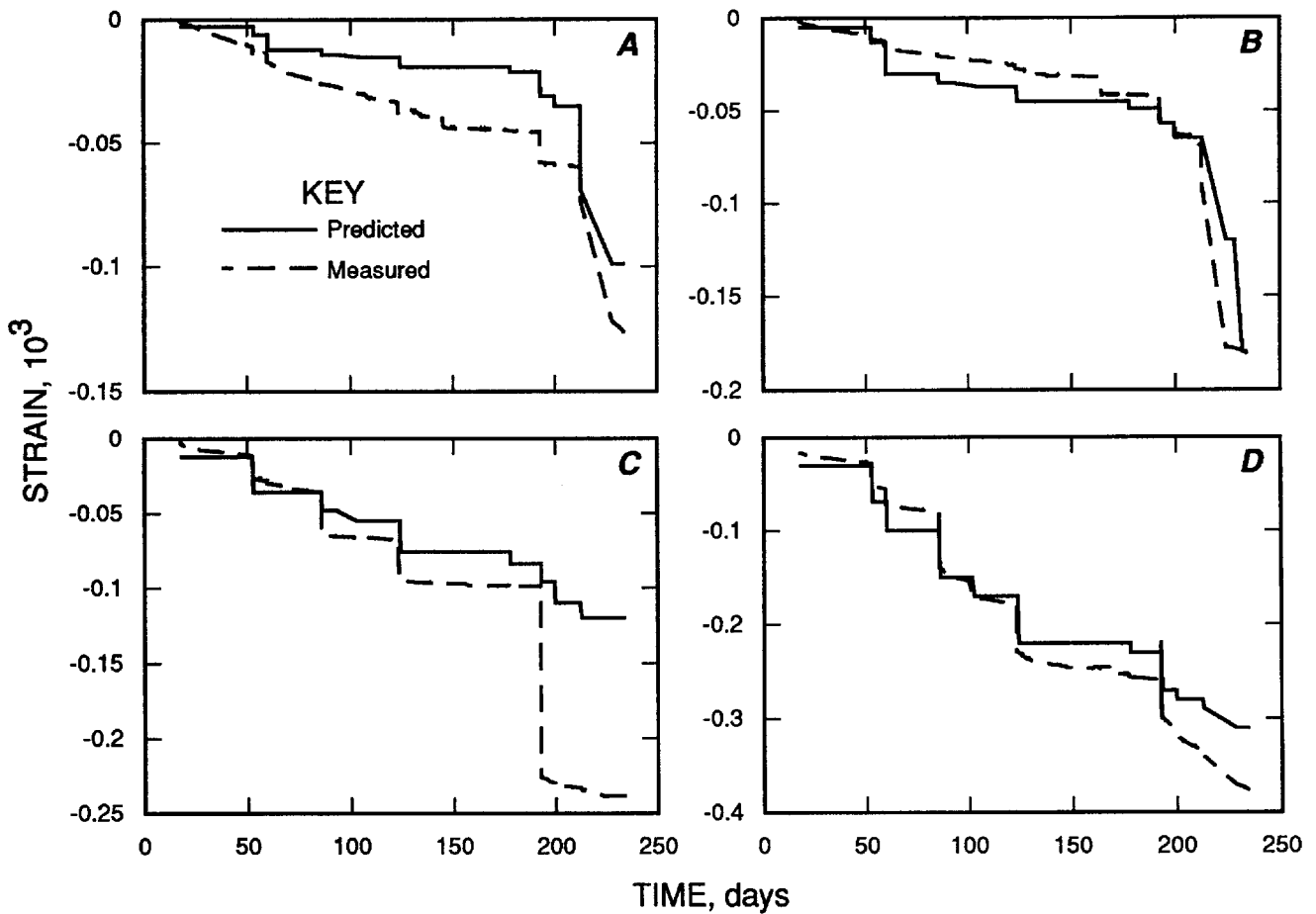

**Measured and predicted vertical strain. A, Pillar 101; B, pillar 102; C, pillar 103; D, pillar 104.**

Figure 14

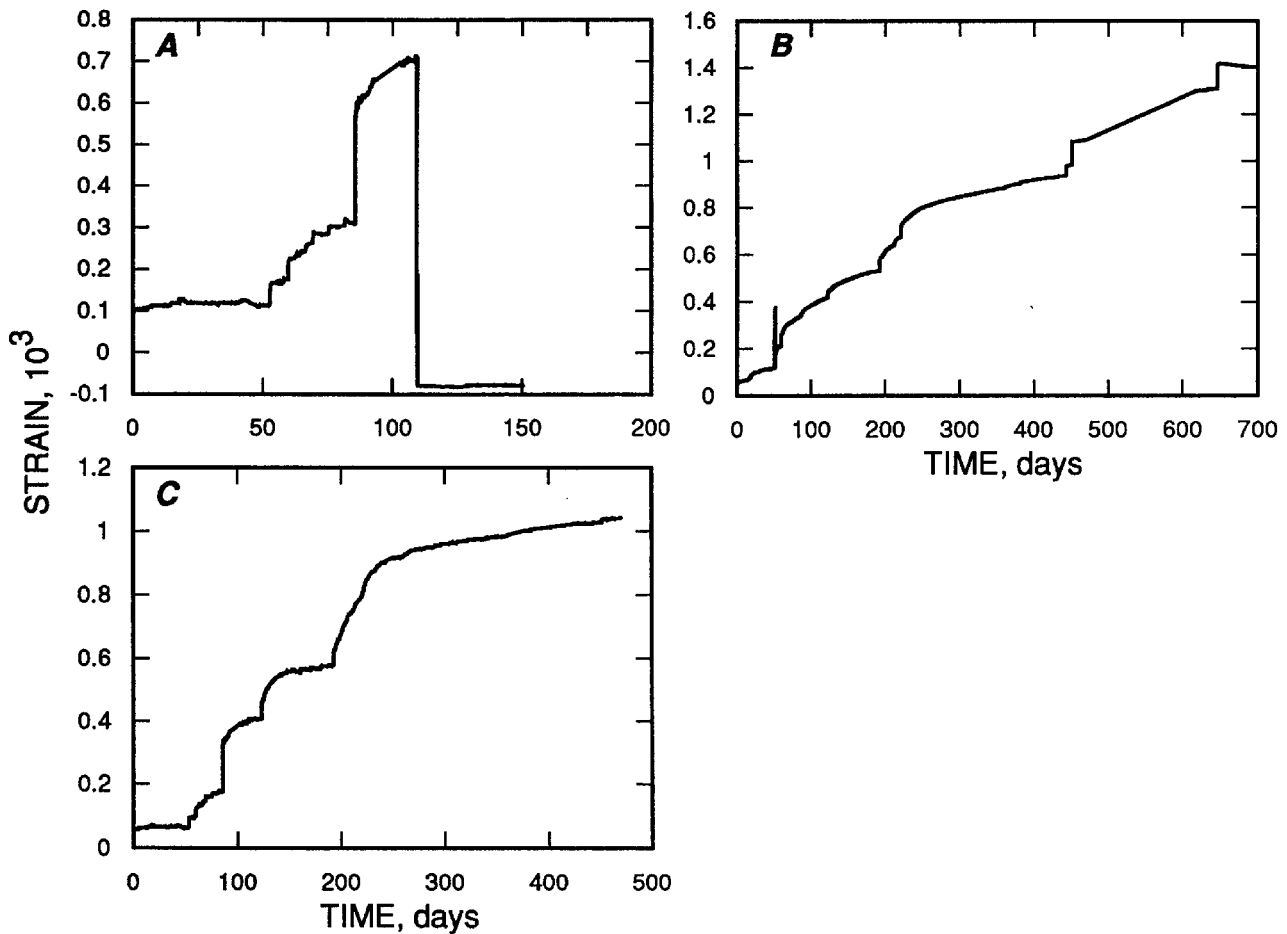

*Horizontal strain measured between downhole anchors. A, Pillar 101; B, pillar 103; C, pillar 104.*

The four vertical borehole extensometers located in the mine roof recorded both compressive and tensile strains when the pillars were mined (figure 15). Strain changes became tensile as more pillars were extracted. None of the extensometers recorded a strain change larger than rock failure strains measured in the laboratory, but without knowledge of prior roof movement, an accurate prediction of whether or not the roof remained elastic cannot be made. However, on the basis of the small strain changes, it was apparent that the roof remained stable during pillar removal.

Secondary principal stress changes calculated from the biaxial stressmeters were erratic and inconsistent with stress changes calculated by BESOL. Erratic readings could have been caused by the narrow excitation frequency range

initially programmed into the datalogger. After this range was increased, the readings became more consistent. However, vertical stress changes that were transformed from measured principal stresses in the north and south abutments were tensional where compressive stresses would be expected. Measured and predicted changes in compressive vertical stress in pillars 102 and 103 are shown in table 11.

**Table 11.—Measured and predicted vertical stress changes in pillars 102 and 103, megapascals**

Location	Day	Measured	Predicted
Pillar 102 .....	392	-3.4	-10.3
Pillar 103 .....	652	-33.4	-16.2



Figure 15

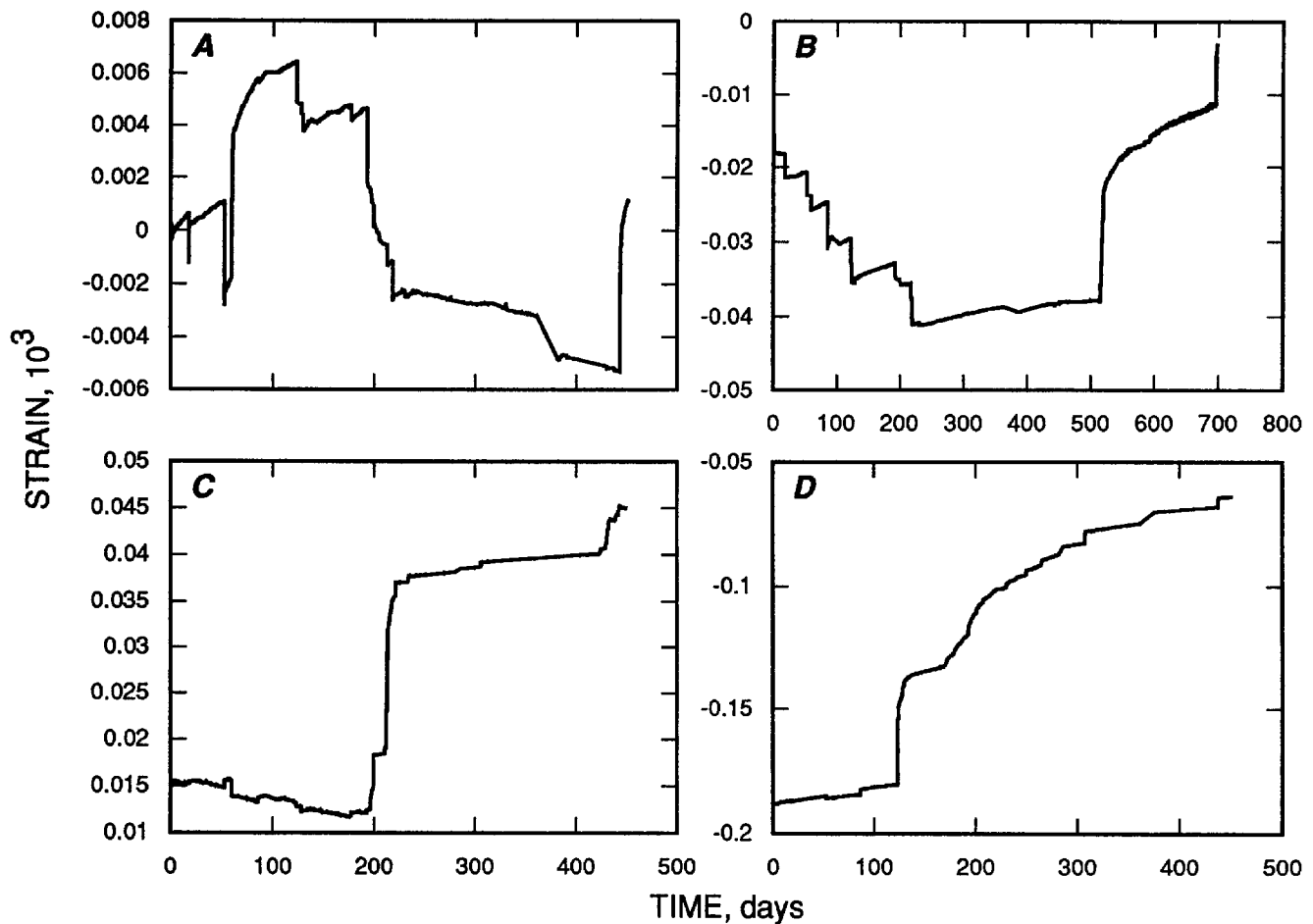

*Vertical strain measured by borehole extensometer in mine roof. A, Pillars 93, 94, 102, and 103; B, pillars 95, 96, 104, and 105; C, pillars 102, 103, 111, and 112; D, pillars 104, 105, 113, and 114.*

## CONCLUSIONS

Readings from instruments installed in cemented backfill at the Buick Mine indicated that the backfill remained in the elastic range. The average maximum compressive stress caused by mining and recorded by earth pressure cells was  $-0.26$  MPa. This value is much lower than the average unconfined compressive strength of backfill specimens derived from laboratory experiments.

From a design perspective, rock fill containing 4-pct cement is adequate to maintain roof and pillar stability for mining remnant support pillars in area 5 at the Buick Mine. For this rock fill to provide support, the gap left between the roof and

fill was less than 1.3 cm in most areas. The top 3 m of backfill had a maximum aggregate diameter of 5 cm and was placed by front-end loaders and slinger trucks. The backfill mix and mining method used in this test project could be applied to sites having similar pillar geometry, in situ stresses, and rock mass properties, such as other mines in the New Lead Belt.

Pillar strains were also monitored and compared with failure strains of laboratory rock specimens. There was no evidence that the perimeter pillars failed, but measured horizontal strain changes in trapped pillars 103 and 104 exceeded laboratory

tensile failure strains, and the extensometers in these pillars stopped recording strain changes after one of the support pillars was blasted. These data indicate that these two pillars failed.

Vertical strain changes in the trapped pillars plotted against predicted strain changes from a numerical model resulted in a calibrated elastic rock modulus of 38,170 MPa. These data also

indicate that pillar 103 failed. A two-dimensional, finite-element computer program having an elastic, perfectly plastic material model was used along with extensometer readings from the trapped pillars to generate an estimate of unconfined compressive strength of the rock as 38.2 Mpa.

## ACKNOWLEDGMENTS

The authors wish to express their appreciation to the management of The Doe Run Co., Buick Mine, St. Louis, MO, and especially to W. L. Lane, manager—mine technical services; R. W. Roscoe, senior planning engineer; J. S. Hawk, mine engineer; and G. F. Sutton, mine engineer, for providing access to the test section of the mine, supplying and maintaining instruments and data acquisition systems, and providing mine maps and schedules. The authors also wish to thank W. G. Pariseau, professor, Department of Mining Engineering, University of Utah, Salt Lake City, UT, for assistance in data analysis; J. D. Vickery, project mine manager,

Kennecott Corp., Bingham Canyon, UT, for initial design work on the vertical backfill extensometer; D. P. Roberts, senior mining engineer, Golder Associates, Burnaby, BC, for instrument data interpretations; L. A. Atkins and F. M. Jones, engineering technicians, USBM, Spokane Research Center (SRC), Spokane, WA, for material property testing and assistance with in situ stress determination; C. C. Clark, mechanical engineer, USBM, SRC, for assistance with horizontal borehole extensometer installation and in situ stress determination; and R. R. Backer, group supervisor, USBM, SRC, for assistance with in situ stress determination.

## REFERENCES

- Bloss, M. L., R. Cowling, and J. L. Meek. A Procedure for the Design of Stable Cemented Fill Exposures. Paper in Minefill 93, ed. by H. W. Glen (Johannesburg, S. Afr., Sept. 1993). Symp. Ser. S13, S. Afr. Inst. Min. Metall., Johannesburg, S. Afr., 1993, pp. 3-8.
- Brechtel, C. E., J. F. T. Agapito, and M. E. Mudlin. Stability Evaluation During Bench Cut-and-Fill Mining of the B-Neath Zone at the Cannon Mine. Proceedings of the SME Annual Meeting and Exhibit (Las Vegas, NV, Feb. 1989). SME 1989a, pp. 1-16.
- Brechtel, C. E., M. P. Hardy, J. Baz-Dresch, and J. S. Knowlson. Application of High-Strength Backfill at the Cannon Mine. Paper in Innovations in Mining Backfill Technology: Proceedings of the 4th International Symposium on Mining with Backfill, ed. by F. P. Hassani, M. J. Scobie, and T. R. Yu (Montreal, PQ, Oct. 2-5, 1989). Balkema, 1989b, pp. 105-117.
- Crouch Research, Inc. (St. Paul, MN). Computer Software for Rock Mechanics, The BESOL System, User's Guide, Part II, Three-Dimensional Programs. Version 1.15. 1986, 68 pp.
- DeSalvo, G. J., and R. W. Gorman. ANSYS Engineering Analysis System Users' Manual. Swanson Analysis Systems, Inc., Houston, PA, v. I, Sec. 3.3, 1989, 118 pp.
- Farmer, I. W. Engineering Properties of Rocks. Butler and Tanner, London, 1968, p. 37.
- Koskela, V. A. Consolidated Backfilling at Outokumpu Oy's Vihanti, Keretti and Vammala Mines. Paper in Mining with Backfill: Proceedings of the International Symposium on Mining with Backfill, ed. by S. Granholm (Lulea, Sweden, June 7-9, 1983). Balkema, 1983, pp. 151-160.
- Pariseau, W. G. 3D Mine Pillar Design Information from 2D FEM Analysis. Int. J. Numer. Anal. Methods in Geomech., v. 3, 1979, pp. 145-157.
- Sowers, G. F. Introductory Soil Mechanics: Geotechnical Engineering. Macmillan, 4th ed., 1979, pp. 180-231.
- Stilwell, A. W. The Extraction of a Steeply Dipping, Wide Gold Reef Using Cemented Backfill. Paper in Minefill 93, ed. by H. W. Glen (Johannesburg, S. Afr., Sept. 1993). Symp. Ser. S13, S. Afr. Inst. Min. Metall., Johannesburg, S. Afr., 1993, pp. 147-155.
- Tesarik, D. R., and R. W. McKibbin. Instrumentation and Modeling of the North 140 Section of Magmont Mine, Bixby, MO. USBM RI 9215, 1989, 30 pp.
- Tesarik, D. R., J. B. Seymour, and M. E. Mudlin. Analysis of Backfill and Pillar Performance in the B-Neath Ore Body at the Cannon Mine. Paper in Minefill 93, ed. by H. W. Glen (Johannesburg, S. Afr., Sept. 1993). Symp. Ser. S13, S. Afr. Inst. Min. Metall., Johannesburg, S. Afr., 1993, pp. 55-64.
- Tesarik, D. R., J. B. Seymour, and J. D. Vickery. Instrumentation and Modeling of the Cannon Mine's B-North Ore Body. Paper in Innovations in Mining Backfill Technology: Proceedings of the 4th International Symposium on Mining with Backfill, ed. by F. P. Hassani, M. J. Scobie, and T. R. Yu (Montreal, PQ, Oct. 2-5, 1989). Balkema, 1989, pp. 119-128.
- Udd, J. E. Backfill Research in Canadian Mines. Paper in Innovations in Mining Backfill Technology: Proceedings of the 4th International Symposium on Mining with Backfill, ed. by F. P. Hassani, M. J. Scobie, and T. R. Yu (Montreal, PQ, Oct. 2-5, 1989). Balkema, 1989, pp. 3-13.