



# Technology News

From the Bureau of Mines, United States Department of the Interior



Technology news describes tested developments from Bureau of Mines programs. It is published to encourage the transfer of this information to the minerals industry and its application in commercial practice. Mention of company or product names is for documentation only and does not imply endorsement of a specific firm or product.

Bureau of Mines research is performed and reported under mandate of the United States Congress. **For a free subscription to Technology News, write to Office of Technology Transfer, Bureau of Mines, MS 6201, 810 7th St NW., Washington, DC 20241-0001.**

No. 436, May 1994

## Stope Leaching Reduces Surface Environmental Impacts From Underground Mining

### Objective

Modify conventional mining practices to reduce significantly the amount of material brought to the surface from underground mines, or to “re-mine” existing surface mine dumps by backfilling empty underground stopes.

### Background

Conventional underground mining practices include excavating the ore and transporting the ore to the surface for processing. Underground mining systems handle tons of solid material to produce kilograms, and sometimes only grams, of final product. Processing of ore on the surface results in most of the excavated material remaining on the surface exposed to long-term degradation from wind and water.

The underground stope leaching mining system (fig. 1) involves applying leach solutions to mineralized rock that has been fragmented by blasting ore in place, or by backfilling empty stopes. Only enough material is removed from the underground mining area (stope) to allow for adequate expansion during the blasting. This reduces the amount of material brought to the surface by at least two-thirds. After blasting, leach solution containing chemicals and/or bacteria is circulated through the fragmented ore to dissolve the target mineral. The resulting solution containing the dissolved mineral (pregnant leach solution) is pumped to the surface where the product is removed, and the leach solution is regenerated for recycling underground.

### Approach

Successful implementation of stope leaching in an underground mine requires control of the leaching solution, as well as economical leaching solutions that are environmentally compatible. Detailed characterization of the rock mass prior to leaching is critical for ensuring solution containment. Preleaching rock-mass characterization locates zones of high permeability, such as fractures that can be sealed prior to introduction of leach solutions.

U.S. Bureau of Mines (USBM) researchers have tested and compared rock-mass characterization procedures utilizing geologic mapping, various geophysical techniques, and hydrologic modeling at an underground test facility at the Edgar Mine (an experimental mine in Idaho Springs, CO), which is owned and operated by the Colorado School of Mines (fig. 2). The test facility was constructed by mining a simulated leaching stope using a blasting technique designed to maximize ore fragmentation and to minimize damage to the wall rock. Boreholes were drilled at intervals around the outside perimeter of the stope for core sampling and characterization of the rock mass. The holes then became monitoring wells when solution was added to the stope.

### Results

Information on geologic features in the Edgar Mine and surrounding area were compiled and evaluated. Detailed geologic mapping of the stope area and core logging

focused on rock fractures. Data evaluation included statistical analysis to determine that the fracture sampling was adequate to represent the rock mass for computer modeling purposes.

Various geophysical techniques were applied inside boreholes surrounding the stope to compare rock fracture data with geologic mapping and core logging. Geophysical testing included electric resistivity, radiometric, single-hole sonic, and cross-hole seismic tomographic logs. The tomographic plot of seismic velocity waves between boreholes gave the best correlation with physical fracture data.

The permeability along borehole intervals was measured by placing expandable packers above and below test intervals and applying air or water pressure. The decay of initial pressure over time was monitored to determine the hydraulic conductivity of each interval. Fracture characteristics and results of permeability tests were used in a computer model, PLUME,<sup>1</sup> to predict the direction and rate of fluid flow into the surrounding rock mass after solution was introduced into the stope. Preliminary results using a salt tracer in solution indicate that the computer model correctly predicted the direction of solution flow into the rock mass.

<sup>1</sup>Reference to specific products does not imply endorsement by the U.S. Bureau of Mines.

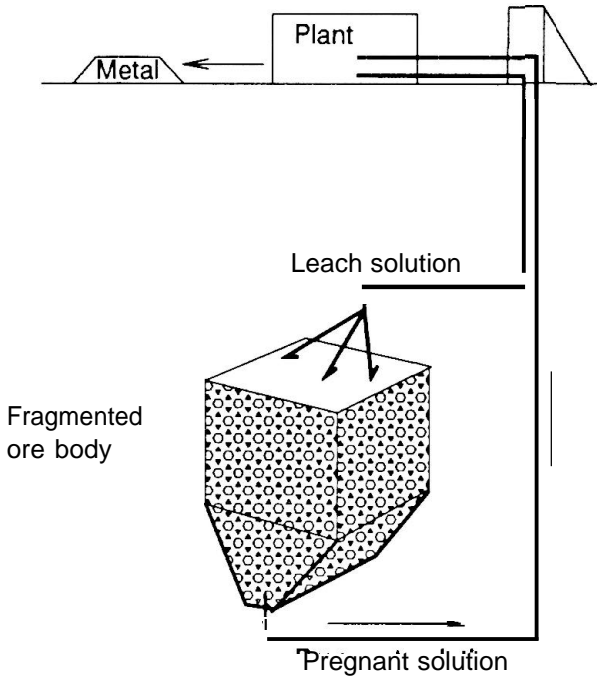

Figure 1.—Stope leaching in underground mines.

Research by the USBM on leaching solution chemistry continues; with progress reported on using sodium thiosulfate for leaching gold from refractory carbonaceous ores, leaching copper from chalcopyrite ores with ferric chloride solution, and preleaching oxidation treatment of various minerals with biological agents.

## Cooperative Research Opportunity

The USBM is seeking cooperators to assist in further research and development of this technology. Additional information on cooperative research may be obtained by contacting Cad H. Schmuck, U.S. Bureau of Mines, Denver Research Center, Bldg. 20, Denver Federal Center, Denver, Colorado 80225, or telephone (303) 236-0701.

## For More Information

A USBM Report of Investigations (RI 9457), Predicting Flow Characteristics of a Lixiviant in a Fractured Crystalline Rock Mass, is available from the author, Nadia C. Miller, U.S. Bureau of Mines, Denver Research Center, Bldg. 20, Denver Federal Center, Denver, Colorado 80225, or telephone (303) 236-0724.

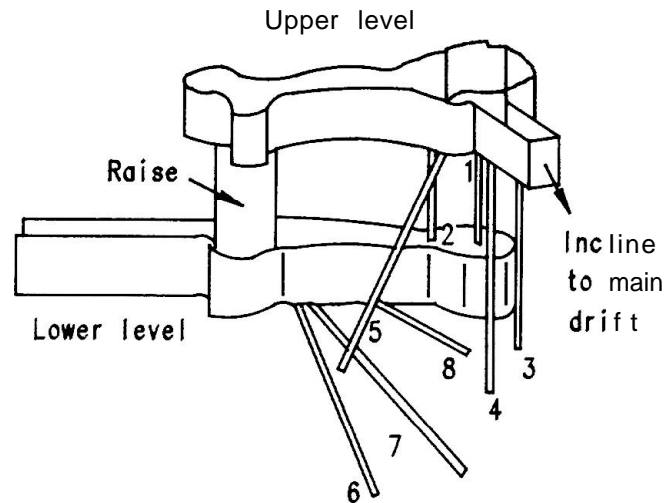

Figure 2.—Three-dimensional view of the solution control research site prior to blasting of the simulated stope.