

# NASA Facts

National Aeronautics and  
Space Administration

**Jet Propulsion Laboratory**  
California Institute of Technology  
Pasadena, CA 91109

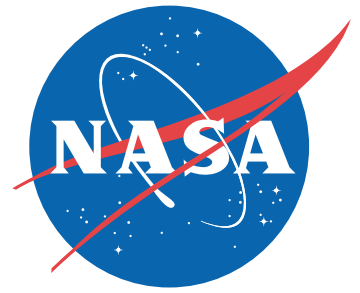

## Stardust

NASA's Stardust mission is sending a spacecraft to fly through the cloud of dust that surrounds the nucleus of a comet – and, for the first time ever, collect cometary material for return to Earth.

Comets, which periodically grace our sky like celestial bottle rockets, are thought to hold many of the original ingredients of the recipe that created the planets and brought plentiful water to Earth.

They are also rich in carbon-based material, which provided our planet with many of the ready-to-mix molecules that could give rise to life. They may be the oldest, most primitive bodies in the solar system, a preserved record of the original nebula that formed the Sun and the planets.

Stardust is the first U.S. mission dedicated solely to a comet. Its main objective is to capture a sample from a well-preserved comet called Wild 2 (pronounced "Vilt 2").

The spacecraft will also collect interstellar dust

from a recently discovered flow of particles that passes through our solar system from interstellar space. As in the proverbial "from dust to dust," this interstellar

dust represents the ultimate in recycled material; it is the stuff from which all solid objects in the universe are made, and the state to which everything eventually returns.

Scientists want to discover the composition of this "stardust" to determine the history, chemistry, physics and mineralogy of nature's most fundamental building blocks.

Because it would be virtually impossible to equip a spacecraft with the most sophisticated lab instrumentation needed to analyze such material in space, the Stardust spacecraft will

act as a robotic lab assistant whose job it is pick up and deliver a sample to scientists back on Earth. The spacecraft will, however, radio back some on-the-spot analytical observations of the comet and interstellar dust.

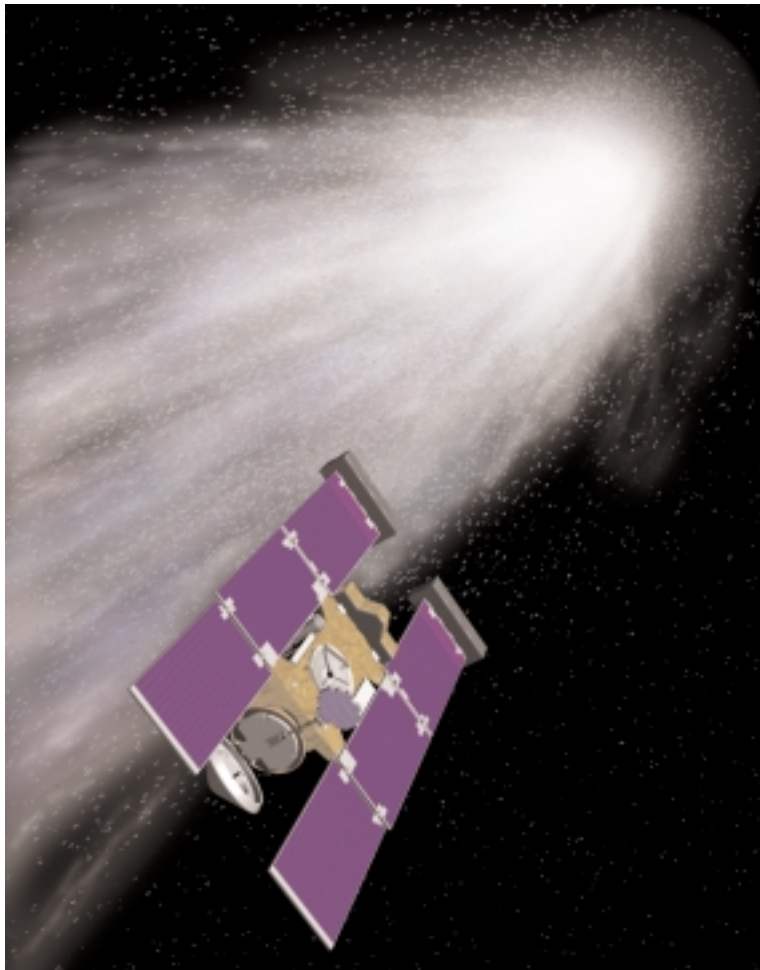

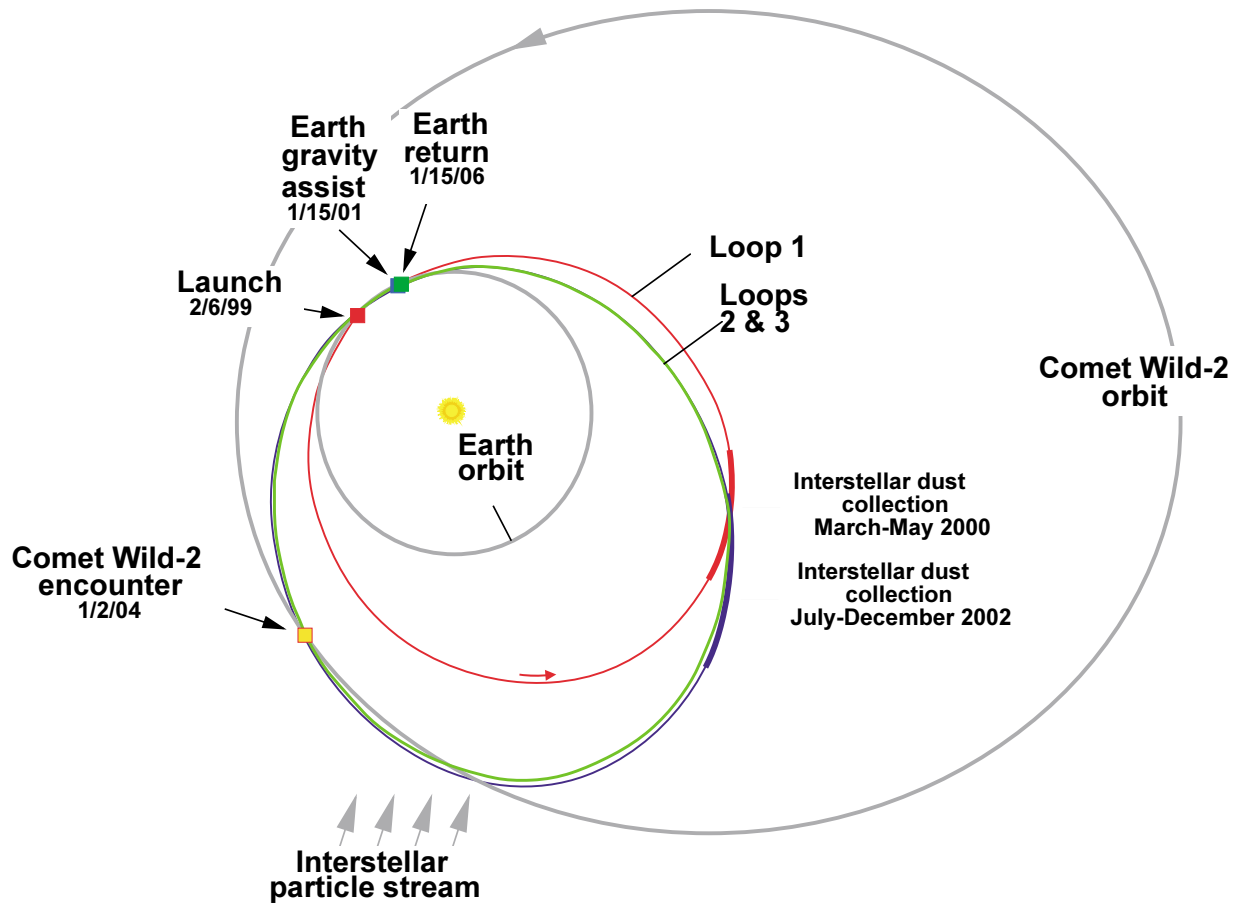

### Mission Overview

Stardust was launched at 4:04 p.m. EST February 7, 1999, atop a Delta II rocket from Florida's Cape Canaveral Air Station. Its flight path is taking it on several looping orbits around the Sun.

From March through May 2000, Stardust opened a collector to catch samples of interstellar particles. On January 15, 2001, the spacecraft will fly by Earth to use its gravity to change the spacecraft's path, passing within 5,964 kilometers (3,706 miles) of its home planet. The flyby will put Stardust on a trajectory that will allow it to reach the comet three years later, approaching at a relatively low speed to keep the dust samples it collects as pristine as possible.

On January 2, 2004, the spacecraft will encounter Comet Wild-2, flying past it at a relative speed of 21,960 kilometers per hour (13,650 miles per hour).

An onboard camera will aid in navigating the spacecraft to the comet's nucleus, permitting the capture of the freshest samples from the heart of the comet.

Stardust will document its passage through the hailstorm of comet debris with scientific instruments and the navigation camera. On approach to the dust cloud, or "coma," the spacecraft will flip open a tennis-racket-shaped particle catcher filled with a silicon-based foam called aerogel to capture the comet particles. Aerogel, the lowest-density material in the world, has enough "give" in it to slow and stop particles without altering them too much. After the sample has been collected, the aerogel capturing device will fold down into a sample return capsule, which closes like a clamshell to enclose the samples for safe delivery to Earth.

A particle impact mass spectrometer will also obtain in-flight data on the composition of both comet and interstellar dust, especially very fine particles. The optical navigation camera should provide excellent images of the dark mass of the comet's nucleus. Other equipment will reveal the distribution in both time and space of coma dust, and could produce an estimate of the comet's mass.

On January 15, 2006, a parachute will set the capsule gently onto the salt flats of the Utah desert for

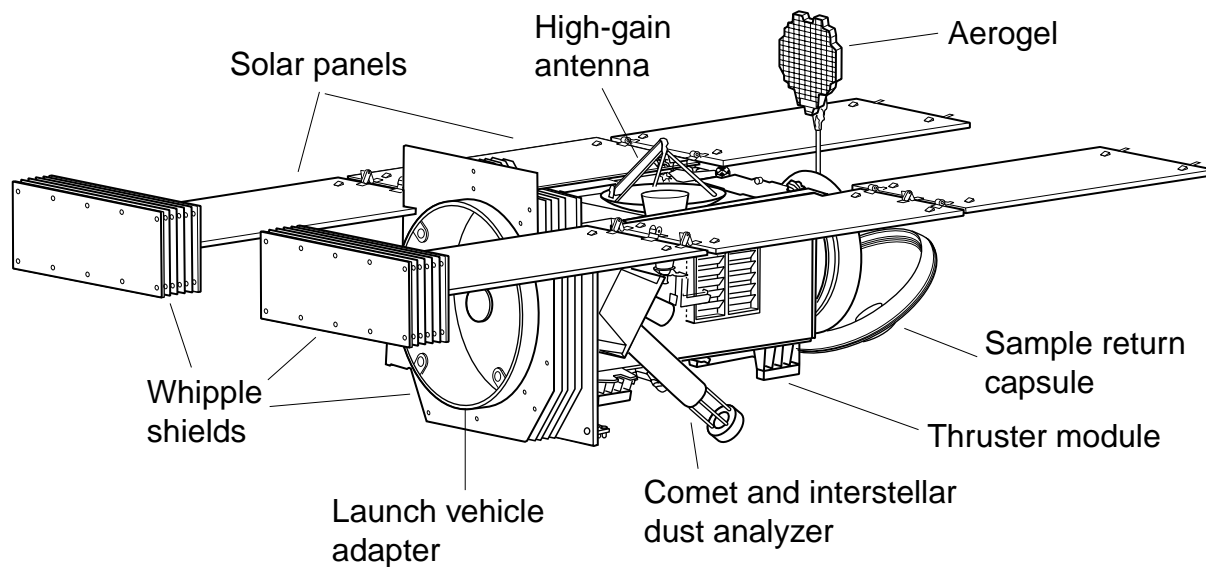

retrieval. The scientifically precious samples can be studied for decades into the future with ever-improving techniques and analysis technologies, limited only by the number of atoms and molecules of the sample material available. Many types of analyses now performed on lunar samples, for example, were not even imagined at the time of the Apollo missions to the Moon.

From Earth to comet to Earth over the course of seven years, the spacecraft will have traveled a total of 5.2 billion kilometers (3.2 billion miles).

### Comet Science

Comets are small, irregularly shaped bodies composed of a mixture of grains of rock, carbon-based molecules and frozen gases. Most comets are about 50 percent water ice. Typically ranging in size up to about 10 kilometers (6 miles) in diameter, comets have highly elliptical orbits that bring them close to the Sun and then swing them back out into deep space. They spend most of their existences in a deep freeze beyond the orbit of Pluto – far beyond the Sun's dwindling influence, which is why so much of their original material is well-preserved.

When a comet approaches within about 700 million kilometers (about a half billion miles) of the Sun, the surface of the nucleus begins to warm, and material on the comet's nucleus heats and begins to vaporize. This process, along with the loss of rocky debris

or other particles that fly off the surface, creates the cloud around the nucleus called the coma. It is the glowing, fuzzy-looking coma that appears as the head of a comet when one is observed from Earth. A tail of luminous debris and another, less apparent, tail of gases flow millions of miles beyond the head in the direction away from the Sun.

Comet Wild 2 is considered an ideal target for study because, until recently, it was a long-period comet that rarely ventured close to the Sun. A fateful pass near Jupiter and its enormous gravity field in 1974 pulled Comet Wild 2 off-course, diverting it onto a tighter orbit that brings it past the Sun more frequently and also closer to Earth's neighborhood. Because Wild 2 has only recently changed its orbit, it has lost little of its original material when compared with other short-period comets, so it offers some of the best-preserved comet samples that can be obtained.

### Program

Stardust was competitively selected in the fall of 1995 under NASA's Discovery Program of low-cost, highly focused science missions. As a Discovery mission, Stardust has met a fast development schedule, uses a small Delta launch vehicle, is cost-capped at less than \$200 million, and is the product of a partnership involving NASA, academia and industry.

The spacecraft was designed, built and is operated

by Lockheed Martin Astronautics, Denver, CO. NASA's Jet Propulsion Laboratory, Pasadena, CA, provided the spacecraft's optical navigation camera, and the Max Planck Institute of Germany provided the real-time dust composition analyzer.

Stardust's principal investigator is Dr. Donald Brownlee of the University of Washington, Seattle. Dr. Peter Tsou of the Jet Propulsion Laboratory is deputy principal investigator.

The Stardust mission is managed by the Jet Propulsion Laboratory for NASA's Office of Space Science, Washington, DC. At NASA Headquarters, Mark Dahl is Stardust program executive and Dr. Thomas Morgan is program scientist.

At the Jet Propulsion Laboratory, Thomas Duxbury is project manager. Robert Ryan is mission director. JPL is a division of the California Institute of Technology, Pasadena, CA.

11/00 MJH