

NASA/CR-2001-211225
ICASE Report No. 2001-28



Piezoelectric Ceramics Characterization

T.L. Jordan
NASA Langley Research Center, Hampton, Virginia

Z. Ounaies
ICASE, Hampton, Virginia

ICASE
NASA Langley Research Center
Hampton, Virginia

Operated by Universities Space Research Association



National Aeronautics and
Space Administration

Langley Research Center
Hampton, Virginia 23681-2199

Prepared for Langley Research Center
under Contract NAS1-97046

September 2001

PIEZOELECTRIC CERAMICS CHARACTERIZATION

T. L. JORDAN¹ AND Z. OUNAIES²

Abstract. This review explores piezoelectric ceramics analysis and characterization. The focus is on polycrystalline ceramics; therefore, single crystals, polymeric materials and organic/inorganic composites are outside the scope of this review. To thoroughly grasp the behavior of a piezoelectric polycrystalline ceramic, a basic understanding of the ceramic itself should not be overlooked. To this end, we have presented a brief introduction of the history of piezoelectricity and a discussion on processing of the ceramic and development of the constitutive relations that define the behavior of a piezoelectric material. We have attempted to cover the most common measurement methods as well as introduce parameters of interest. Excellent sources for more in-depth coverage of specific topics can be found in the bibliography. In most cases, we refer to lead zirconate titanate (PZT) to illustrate some of the concepts since it is the most widely used and studied piezoelectric ceramic to date.

Subject classification. Structures and Materials

Key words. piezoelectricity, crystalline ceramic, ferroelectricity, piezoelectric coefficient, hysteresis, poling, piezoelectric characterization

1. Piezoelectric Materials: History and Processing. Smart materials are materials that undergo transformations through physical interactions. An alternate definition is that a smart material is a material that senses a change in its environment and through the use of a feedback system, adapts to correct or eliminate such a change. Piezoelectric materials, shape-memory alloys, electrostrictive materials, magnetostrictive materials, electrorheological fluids are some examples of currently available smart materials.

Piezoelectricity stems from the Greek word *piezo* for pressure. It follows that a piezoelectric material develops a potential across its boundaries when subjected to a mechanical stress (or pressure), and vice versa, when an electric field is applied to the material, a mechanical deformation ensues. Piezoelectric materials therefore fall in the class of smart materials. Ferroelectricity is a subgroup of piezoelectricity, where a spontaneous polarization exists that can be reoriented by application of an AC electric field.

1.1. Definition and History. Piezoelectricity is a linear effect that is related to the microscopic structure of the solid. Some ceramic materials become electrically polarized when they are strained; this linear and reversible phenomenon is referred to as *the direct piezoelectric effect*. The direct piezoelectric effect is always accompanied by *the converse piezoelectric effect* where a solid becomes strained when placed in an electric field. The microscopic origin of the piezoelectric effect is the displacement of ionic charges within a crystal structure. In the absence of external strain, the charge distribution within the crystal is symmetric and the net electric dipole moment is zero. However when an external stress is applied, the charges are displaced and the charge distribution is no longer symmetric. A net polarization develops and results in an internal electric field. A material can only be piezoelectric if the unit cell has no center of inversion.

Piezoelectricity is a property possessed by a group of materials, discovered in 1880 by Pierre and Jacques Curie during their study of the effects of pressure on the generation of electrical charge by crystals such as Quartz, tourmaline, and Rochelle salt. In 1881, the term "piezoelectricity" was first suggested by W. Hankel, and the

¹ M/S 238, NASA Langley Research Center, Hampton, VA 23681.

² ICASE, M/S 132C, NASA Langley Research Center, Hampton, VA 23681-2199. This research was supported by the National Aeronautics and Space Administration under NASA Contract No. NAS1-97046 while the second author was in residence at ICASE, NASA Langley Research Center, Hampton, VA 23681-2199.

converse effect was deduced by Lipmann from thermodynamics principles. In the next three decades, collaborations within the European scientific community established the field of piezoelectricity; and by 1910, Voigt's "Lerbuch der Kristallphysic" was published and became a standard reference work detailing the complex electromechanical relationships in piezoelectric crystals [1]. However, the complexity of the science of piezoelectricity made it difficult for it to mature to an application until a few years later. Langevin et al. [2] developed a piezoelectric ultrasonic transducer during World War I. Their success opened up opportunities for piezoelectric materials in underwater applications as well as a host of other applications such as ultrasonic transducers, microphones, accelerometers, etc...In 1935, Busch and Scherrer discovered piezoelectricity in potassium dihydrogen phosphate (KDP). The KDP family was the first major family of piezoelectrics and ferroelectrics to be discovered.

During World War II, research in piezoelectric materials expanded to the U.S., the Soviet Union and Japan. Up until then, limited performance by these materials inhibited commercialization but that changed when a major breakthrough came with the discovery of barium titanate and lead zirconate titanate (PZT) in the 1940s and 1950s respectively. These families of materials exhibited very high dielectric and piezoelectric properties. Furthermore, they offered the possibility of tailoring their behavior to specific responses and applications by the use of dopants. To date, PZT is one of the most widely used piezoelectric materials. It is noted that most commercially available ceramics (such as barium titanate and PZT) are based on the perovskite structure (Figure 1). The perovskite structure (ABO_3) is the simplest arrangement where the corner-sharing oxygen octahedra are linked together in a regular cubic array with smaller cations (Ti, Zr, Sn, Nb etc.) occupying the central octahedral B-site, and larger cations (Pb, Ba, Sr, Ca, Na etc.) filling the interstices between octahedra in the larger A-site. Compounds such as $BaTiO_3$, $PbTiO_3$, $PbZrO_3$, $NaNbO_3$ and $KNbO_3$ have been studied at length and their high temperature ferroelectric and antiferroelectric phases have been extensively exploited. This structure also allows for multiple substitutions on the A-site and B-site resulting in a number of useful though more complex compounds such as $(Ba,Sr)TiO_3$, $(Pb,Sr)(Zr,Ti)O_3$, $Pb(Fe,Ta)O_3$, $(KBi)TiO_3$ etc.

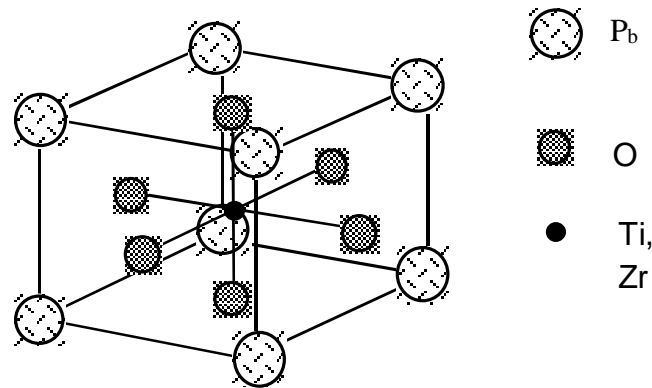

Fig 1. Perovskite structure

Starting around 1965, several Japanese companies focused on developing new processes and applications, and opening new commercial markets for piezoelectric devices. The success of the Japanese effort attracted other nations, and today the needs and uses extend from medical applications to the communications field to military applications and the automotive field.

A review of the early history of piezoelectricity is found in the work of W.G. Cady [3]; and in 1971 Jaffe, Cook and Jaffe published the book “Piezoelectric Ceramics” [4] that is still one of the most referenced works on piezoelectricity.

1.2. Piezoelectric Ceramic Processing. The fabrication of most bulk piezoelectric ceramics starts with powder preparation. The powder is then pressed to the required shapes and sizes, and the green shapes are in turn processed to mechanically strong and dense ceramics. The more important processes that influence the product characteristics and properties are powder preparation, powder calcining and sintering. The next steps are machining, electroding and poling: application of a DC field to orient the dipoles and induce piezoelectricity.

The most common powder preparation is the mixed oxide route. In this process, powder is prepared from the appropriate stoichiometric mixture of the constituents’ oxides. In the case of lead zirconate titanate (PZT): lead oxide, titanium oxide, and zirconium oxide are the main compounds. Depending on application, various dopants are used to tailor the properties of interest. PZT ceramics are rarely utilized without the addition of dopants to modify some of their properties. A-site additives tend to lower the dissipation factor, which affects heat generation, but also lower the piezoelectric coefficients; for this reason they are mostly used in ultrasonics and other high frequency applications. B-site dopants increase the piezoelectric coefficients but also increase the dielectric constant and loss. They are utilized as actuators in vibration and noise control, benders, optical positioning application etc.

Figure 2 shows a flowchart of the mixed oxide route for making PZT ceramics. Mixing of the powders can be done by dry-ball milling or wet ball milling, both methods having advantages and disadvantages: wet ball-milling is faster than dry-milling; however, the disadvantage is the added step of liquid removal. The most common method for making PZT ceramics is through wet-ball milling; ethanol and stabilized zirconia media are added for a wet milling process. A vibratory mill may be used rather than a conventional ball mill; it was shown by Herner [5] that this process reduces the risk of contamination by the balls and the jar. Zirconia media are used to further reduce the contamination risks. The calcination step is a very crucial step in the processing of PZT ceramics; it is important that the crystallization be complete and that the perovskite phase forms during this step. The goals are to remove any organics, water or other volatiles left after mixing; to react the oxides to form the desired phase composition before the ceramic is processed to useful devices; and to reduce volume shrinkage and allow for better homogeneity during and after sintering.

After calcining, a binder is added to the powder, then the mixture is shaped usually by dry-pressing in a die for simple shapes, or extrusion, or casting for more complicated bodies. Next, the shapes are sintered: placed in an oven for binder burn-out and densification.

The major problem in the sintering of the PZT ceramic is the volatility of PbO at about 800°C. To minimize this problem, the PZT samples are sintered in the presence of a lead source, such as PbZrO₃, and placed in closed crucibles. The saturation of the sintering atmosphere with PbO minimizes lead loss from the PZT bodies. Sintering can now be carried out at temperatures varying between 1200-1300°C. Despite precautions, there is usually a resulting loss of 2%-3% of the initial lead content.

After cutting and machining into desired shapes, electrodes are applied and a strong DC field is used to orient the domains in the polycrystalline ceramic. DC poling can be done at room temperature or at higher temperatures depending on the material and the composition. The poling process only partially aligns the dipoles in a polycrystalline ceramic, and the resulting polarization is lower than that for single crystals.

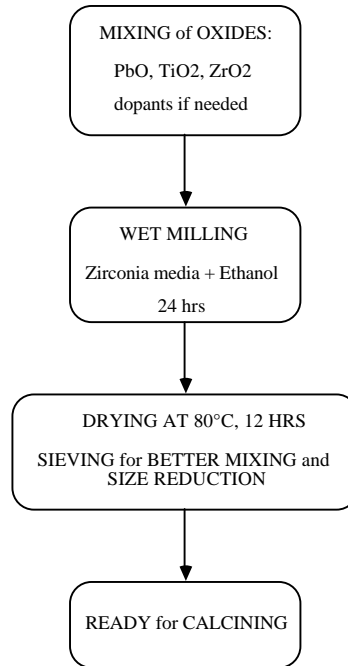

Fig 2. *Mixed-oxide route of preparing PZT*

This processing technique presents many uncertainties and the presence of a wide number of other fabrication techniques is an indication that there is a great need for the production of reliable PZT ceramics with optimum properties and microstructure. One problem often encountered is the deviation from stoichiometry. This problem is often due to impurities present in the raw materials as well as the lead loss during the sintering process, which invariably results in substantial alterations of the PZT properties. As a result, the elastic properties can vary as much as 5%, the piezoelectric properties 10% and the dielectric properties 20% within the same batch [6]. Also, the piezoelectric and dielectric properties generally suffer if there is any lack of homogeneity due to poor mixing. It is important then that the constituent oxides be intimately mixed. In the method described above, however, the constituents are solid solutions and it has been shown that an intimate mixing of solid solutions is difficult if not impossible. More information on the preparation of piezoelectric ceramics can be found in Jaffe, Cook and Jaffe [4], and Moulson and Herbert [7] among others. Other processing methods including hydrothermal processing and co-precipitation methods are described in references [8-10]. It is noted that there has been a great deal of development in powder processing, shaping and sintering [11,12,13] that has resulted in further expanding the application of piezoelectric ceramics.

1.3. Ferroelectricity. Some piezoelectric materials are also ferroelectric. A ferroelectric material possesses a spontaneous polarization that can be reversed in direction by application of a realizable electric field over some temperature range. Most ferroelectric materials have a Curie Temperature, T_c below which they are polar and above which they are not. The dielectric permittivity often has a peak at T_c and linearly decreases according to the Curie-Weiss law above it [4,7]. The very large permittivity values that are characteristics of ferroelectric materials are greatly exploited in many applications, most widely in the multilayer-capacitor industry.

Applying a large alternating electric field causes the polarization to reverse, and this gives rise to the ferroelectric hysteresis loop, relating the polarization P to the applied electric field E . A typical field-polarization

loop is illustrated in Figure 3. At large signals, both the electric displacement D and the polarization P are non-linear functions of the field E . They are related to each other through the linear equation below

$$D_i = P_i + \epsilon_0 E_i \quad (1)$$

where ϵ_0 is the permittivity of free space ($=8.85 \times 10^{-12}$ C/V-m). For most ferroelectric ceramics, the second term in equation (1) is negligible, and a D-E loop and P-E loop become interchangeable. Two key characteristics of the P-E loop are the coercive field E_c and the remanent polarization P_r , both defined by analogy to ferromagnetic materials. E_c is the field at which the polarization is zero. P_r is the value of the polarization when the electric field is zero. Once the field is switched off, the material will have a polarization equal to P_r . Once the P-E loop is saturated both P_r and E_c can be determined. A loop is said to be saturated once the values of P_r and E_c no longer vary.

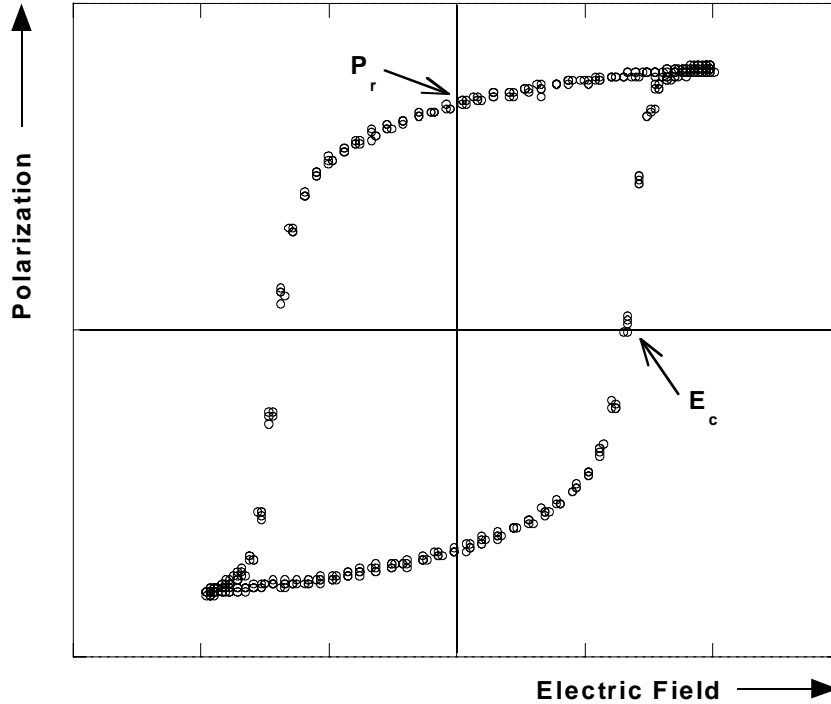

Fig 3. Hysteresis loop of a poled piezoelectric ceramic

Generally, the existence of the P-E loop is considered as evidence towards establishing that a material is ferroelectric. A Sawyer-Tower circuit [14] or a modified version of it, is commonly used to obtain a P-E loop. An AC voltage is applied to the electroded sample; the resulting charge stored on the sample is determined by means of a large reference capacitor placed in series with the sample. An electrometer can be used to detect the voltage across the capacitor; by multiplying this voltage with the value of the reference capacitor, the charge across the sample

results. The reference capacitor should be 100 to 1000 times the value of the capacitance of the sample. It is noted that ferroelectric hysteresis loops are both frequency and temperature dependent.

In addition to the P-E loop, polarization switching leads to strain-electric field hysteresis. A typical strain-field response curve is shown in Figure 4. The shape resembles that of a butterfly, and it is often referred to as the “butterfly loop”. As the electric field is applied, the converse piezoelectric effect dictates that a strain results. As the field is increased, the strain is no longer linear with the field as domain walls start switching. For more sources on ferroelectricity, the reader should consult the bibliography [15-19].

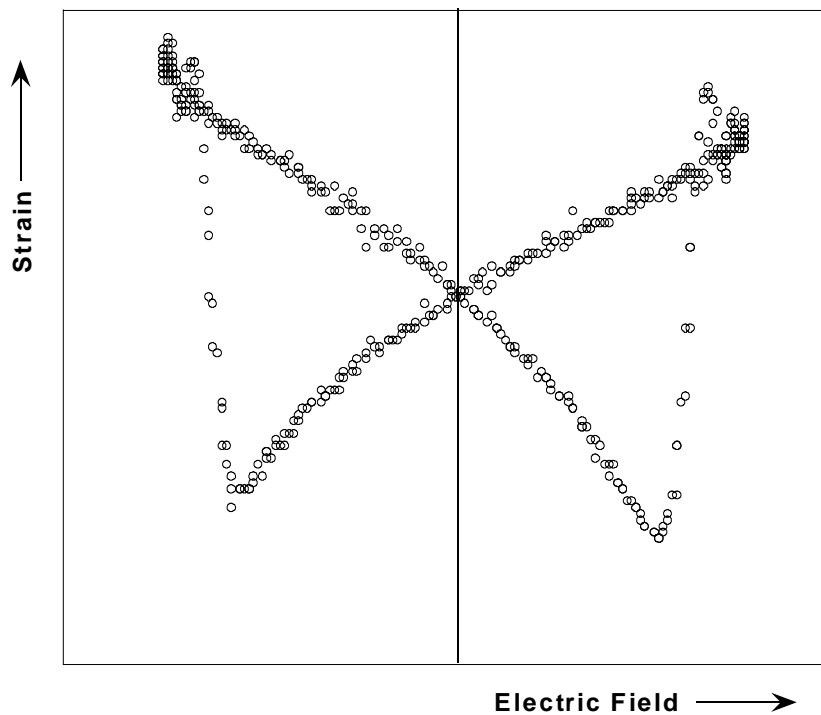

Fig 4. Butterfly loop indicating switching

2. Constitutive Relations and Materials Property. An understanding of piezoelectricity begins with the structure of the material. To better explain it, let us consider a single crystallite (small single crystal less than 100 μm in average diameter) from a polycrystalline ceramic. This crystal is made up of negatively and positively charged atoms occupying specific positions in a repeating unit or cell. The specific symmetry of the unit cell determines the possibility of piezoelectricity in the crystal. All crystals can be divided into 32 classes or point groups (from 7 basic crystal systems: triclinic, monoclinic, orthorhombic, tetragonal, rhombohedral, hexagonal and cubic). Of the 32 classes, 21 do not possess a center of symmetry, and 20 are piezoelectric (one class, although lacking a center of symmetry, is not piezoelectric because of the combination of other symmetry elements). The lack of center of symmetry means that a net movement of the positive and negative ions with respect to each other as a result of stress

produces an electric dipole. The ceramic, being composed of the random orientation of these piezoelectric crystallites, is inactive, i.e., the effects from the individual crystals cancel each other and no discernable piezoelectricity is present. Regions of equally oriented polarization vectors are known as domains. "Poling" is a commonly used method to orient the domains by polarizing the ceramic through the application of a static electric field. The electrodes are applied to the ceramic and a sufficiently high electric field is applied such that the domains rotate and switch in the direction of the electric field. The result is never a full orientation of all domains; however the polycrystalline ceramic exhibits a large piezoelectric effect. During this process, there is a small expansion of the material along the poling axis and a contraction in both directions perpendicular to it (see Figure 5). With a large number of allowable polar directions such as near the morphotropic phase boundary (where the Zr to Ti ratio is equal to 48 to 52), the maximum deviation of the polar axis of a grain from the average polar direction will be smaller, and the lowering of the polarization will be minimized assuming optimum alignment.

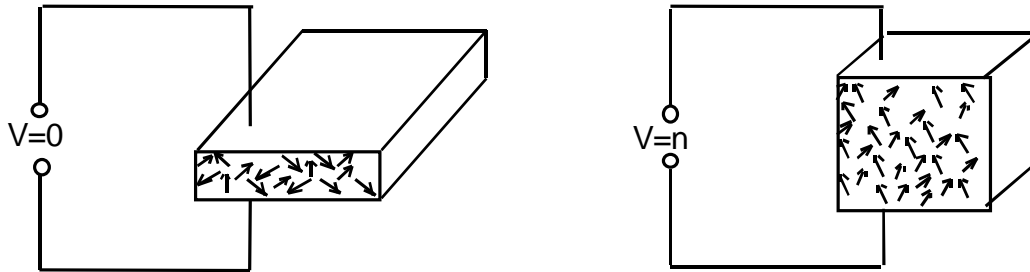

Fig 5. Poling of a piezoelectric, ferroelectric ceramic

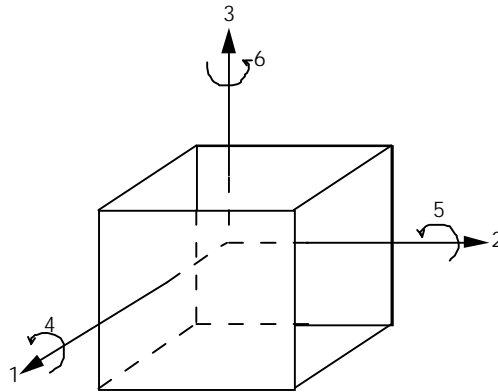

Fig 6. Reference axes

2.1. Constitutive Relations. When writing the constitutive equation for a piezoelectric material, account must be taken of changes of strain and electrical displacement in three orthogonal directions caused by cross-coupling effects due to applied electrical and mechanical stresses. Tensor notation is first adopted, and the reference axes are shown in Figure 6.

The state of strain is described by a second rank tensor S_{ij} , and the state of stress is also described by a second rank tensor T_{kl} . The relationships relating the stress tensor to the strain tensor, compliance s_{ijkl} , and stiffness c_{ijkl} , are then fourth rank tensors. The relationship between the electric field E_j (first rank tensor) and the electric displacement D_i (also a first rank tensor) is the permittivity ϵ_{ij} , which is a second rank tensor. The piezoelectric equations are therefore written as:

$$D_i = \epsilon_{ij}^T E_j + d_{ijk} T_{jk} \quad (2)$$

$$S_{ij} = \underline{d}_{ijk} E_k + s_{ijkl}^E T_{kl} \quad (3)$$

where d_{ijk} , \underline{d}_{ijk} are the piezoelectric constants (third rank tensor). Superscripts T and E denote that the dielectric constant ϵ_{ij} and the elastic constant s_{ijkl} are measured under conditions of constant stress and constant electric field respectively. In general, a first rank tensor has three components, a second rank tensor has nine components, a third rank tensor has 27 components and a fourth rank tensor has 81 components. Not all the tensor components are independent. Both these relations are orientation-dependent; they describe a set of equations that relate these properties in different orientations of the material. The crystal symmetry and the choice of reference axes reduce the number of independent components. A convenient way of describing them is by using axis directions as given by Figure 6. The convention is to define the poling direction as the 3-axis, the shear planes are indicated by the subscripts 4, 5 and 6 and are perpendicular to directions 1, 2 and 3 respectively. This simplifies the notations introduced above, where a 3-subscript tensor notation (i,j,k = 1,2,3) is replaced by a 2-subscript matrix notation (i=1,2,3 and j=1,2,3,4,5,6), and a 2-subscript tensor notation (i,j = 1,2,3) is replaced by a 1-subscript matrix notation (i=1,2,3,4,5,6). A shear strain such as S4 is a measure of the change of angle between the two initially orthogonal axes in the plane perpendicular to axis 1. The first subscript of the d-constant gives the "electrical" direction (field or dielectric displacement) and the second gives the component of mechanical deformation or stress. The planar isotropy of poled ceramics is expressed in their piezoelectric constants by the equalities $d_{32}=d_{31}$ (an electric field parallel to the poling axis 3 interacts in the same way with axial stress along either the 2-axis or the 1-axis) and $d_{24}=d_{15}$ (an electric field parallel to the 2-axis interacts in the same way with a shear in the 2,3-plane as a field along the 1-axis with a shear in the 1,3-plane). Similar relations hold for the elastic constants because of the isotropy in the plane perpendicular to the polar axis.

2.2. Property Matrix for a Poled Piezoelectric Ceramic. A piezoelectric ceramic has only one type of piezoelectric matrix regardless of the symmetry of the constituent crystals. The ceramic is initially isotropic. This isotropy is destroyed in the poling direction. In the directions perpendicular to the poling direction, the material is transversely isotropic. The symmetry elements are an axis of rotation of infinite order in the direction of poling and an infinite set of planes parallel to the polar axis as reflection planes. In crystallographic notation, this symmetry is described as ∞mm and is equivalent to the hexagonal polar crystal class, $6mm$.

The elastic, dielectric and piezoelectric matrices for the cylindrical symmetry of poled PZT are shown in the equations below. Matrices analogous to the piezoelectric one also apply to other piezoelectric constants such as g_{ij} (described in the next section).

$$\begin{array}{cccccc}
s_{11} & s_{12} & s_{13} & 0 & 0 & 0 \\
s_{12} & s_{11} & s_{13} & 0 & 0 & 0 \\
s_{13} & s_{13} & s_{33} & 0 & 0 & 0 \\
0 & 0 & 0 & s_{44} & 0 & 0 \\
0 & 0 & 0 & 0 & s_{44} & 0 \\
0 & 0 & 0 & 0 & 0 & 2(s_{11} - s_{12})
\end{array} \quad (4)$$

$$\begin{array}{ccc}
\varepsilon_1 & 0 & 0 \\
0 & \varepsilon_1 & 0 \\
0 & 0 & \varepsilon_3
\end{array} \quad (5)$$

$$\begin{array}{cccccc}
0 & 0 & 0 & 0 & d_{15} & 0 \\
0 & 0 & 0 & d_{15} & 0 & 0 \\
d_{31} & d_{31} & d_{33} & 0 & 0 & 0
\end{array} \quad (6)$$

For the symmetry of poled ceramics then, the general equations (1) and (2) are replaced by the specific equations below:

$$D_1 = \varepsilon_1 E_1 + d_{15} T_5 \quad (7)$$

$$D_2 = \varepsilon_2 E_2 + d_{15} T_4 \quad (8)$$

$$D_3 = \varepsilon_3 E_3 + d_{31} (T_1 + T_2) + d_{33} T_3 \quad (9)$$

$$S_1 = s_{11}^E T_1 + s_{12}^E T_2 + s_{13}^E T_3 + d_{31} E_3 \quad (10)$$

$$S_2 = s_{11}^E T_2 + s_{12}^E T_1 + s_{13}^E T_3 + d_{31} E_3 \quad (11)$$

$$S_3 = s_{13}^E (T_1 + T_2) + s_{33}^E T_3 + d_{33} E_3 \quad (12)$$

$$S_4 = s_{44}^E T_4 + d_{15} E_2 \quad (13)$$

$$S_5 = s_{44}^E T_5 + d_{15} E_1 \quad (14)$$

$$S_6 = s_{66}^E T_6 \quad (15)$$

Equations (7)-(9) relate to the direct effect, equations (10)-(15) relate to the converse effect.

3. Piezoelectric Parameters: Definitions and Characterization. The parameters that are of interest when considering the electromechanical effects of piezoelectric materials are the piezoelectric charge coefficients (d_{31} and d_{33}), the piezoelectric voltage coefficients (g_{31} and g_{33}) and the piezoelectric coupling factors (k_{31} , k_{33} , k_p and k_r). The d -coefficient is the proportionality constant between electric displacement and stress, or strain and electric field (equations (2) and (3)). High d -coefficients are desirable in materials utilized as actuators, such as in motional and vibrational applications. The g -coefficient is related to the d -coefficient by the following expression:

$$d_{mi} = \epsilon_{nm}^T g_{ni} \quad (16)$$

where $m, n = 1, 2, 3$ and $i = 1, 2, \dots, 6$. High g -coefficients are desirable in materials intended to be used as sensors, to produce voltage in response to mechanical stress.

The piezoelectric coupling factor k is a measurement of the overall strength of the electromechanical effect. It is often defined as the square root of the ratio of electrical energy output to the total mechanical energy input (in the case of the direct effect) or the mechanical energy available to the total electrical energy (in the case of the converse effect). The value of k is of course always less than unity because energy conversion is always incomplete.

Other important properties of PZT are the dielectric properties, namely the dielectric constant ϵ (F/m) and the dissipation factor or loss tangent $\tan\delta$. The dielectric constant is a measure of the charge stored on an electroded material brought to a given voltage. The dielectric constant of vacuum is $\epsilon_0 = 8.85 \times 10^{-12}$ F/m. The relative dielectric constant K (often referred to as just “the dielectric constant”) is the ratio of ϵ and ϵ_0 , and is dimensionless. In case of ac field, the dielectric constant has both a real part and an imaginary part; the loss tangent is defined as the ratio of the imaginary part to the real part.

The values of these constants depend on the PZT compositions. As an example, the d -constants, g -constants and the dielectric constant for compositions near the morphotropic phase boundary show their highest values on the tetragonal side of the transition [4]. It is then possible to tune the values of these properties for most compositions; one way of achieving that is through adding dopants to the PZT formulation.

3.1. Resonant Method and Equivalent Circuit

3.1.1. Resonance method. Any body of mass has certain characteristic frequencies at which it prefers to resonate. When excited at this resonant frequency, f_r , the body will resonate freely with a greater amplitude than at other frequencies. Following this resonant frequency is an anti-resonant frequency, f_a , where the impedance of the body is at a maximum and the oscillation amplitude is at a minimum. Piezoelectric ceramics are no different and the measurement of these characteristic frequencies provides the means to evaluate the piezoelectric and elastic properties of the ceramic. Different modes of vibration of the ceramic, such as thickness or planar, give insight to the different constants associated with that mode. A typical resonance plot of impedance versus frequency for a piezoelectric ceramic near a resonance is shown in Figure 7. Notice the resonant frequency, f_r , at the point of minimum impedance and the anti-resonant frequency, f_a , at the point of maximum impedance.

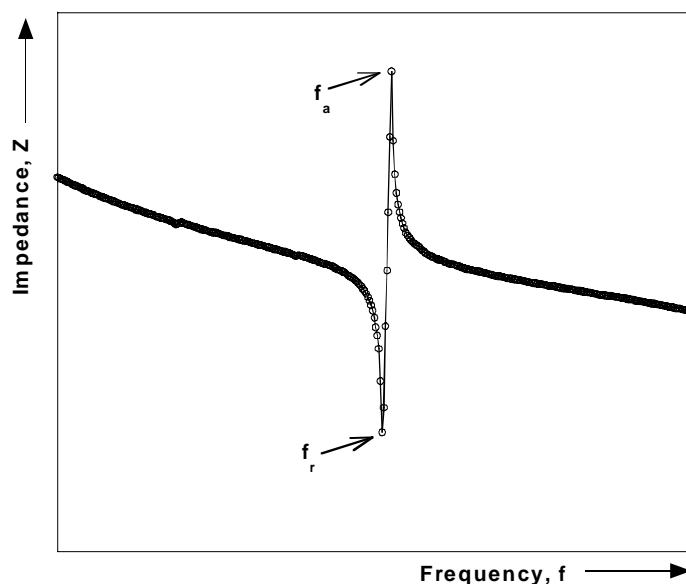

Fig 7. Impedance of a piezoelectric ceramic at resonance

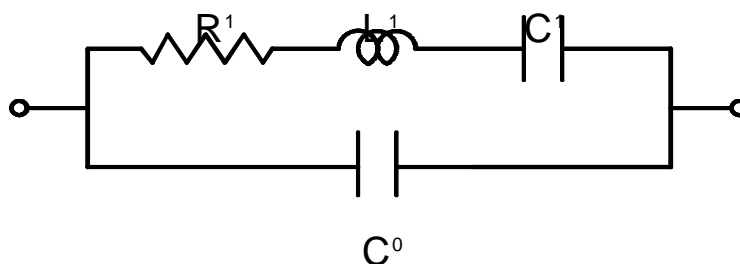

Fig 8. Resonant equivalent circuit of a piezoelectric vibrator

At resonance, a piezoelectric element may be modeled by the equivalent circuit as shown in Figure 8. This circuit is commonly referred to as Van Dyke's Model and is recommended by the IEEE Standard on Piezoelectricity [20]. An alternate model, proposed by Sherrit et al. [21], eliminates the resistance, R_1 , and instead represents the remaining components as complex to better characterize the losses associated with certain piezoelectric elements, especially polymers. All discussion presented below will assume Van Dyke's Model. Below f_r and above f_a , the ceramic behaves capacitively; however between these two frequencies, the ceramic behaves inductively. This model is only valid near the resonance. Additionally, the resonance must be sufficiently isolated from other modes to eliminate the effects of any adjacent modes. To assure isolation of the resonance, sample geometry must be chosen carefully. Geometries suitable for measuring the different piezoelectric and elastic coefficients are presented in Table 1. Fixturing of the sample should not impose any constraints on the vibration of the ceramic. This can be

accomplished by using a point holder positioned at a node of vibration. Also, all leads should be shielded up to the contact point as much as possible to avoid any stray capacitances which may arise.

Earlier literature has suggested several circuits to measure f_r and f_a of a piezoelectric ceramic [22-25]. These circuits usually consist of an oscillator for exciting the sample, a voltmeter or other device for measuring current through the circuit, and additional discrete components. To find f_r , the oscillator is varied in frequency until the maximum current is detected through the circuit. Similarly, for f_a , the frequency of minimum current is determined. It should be noted that there are actually six characteristic frequencies that may be identified for a particular resonance which include f_m and f_n , the frequencies of maximum and minimum impedance; f_r and f_a , the resonant and antiresonant frequencies; and f_p and f_s , the parallel resonant frequency and series resonant frequency. IEEE Standard 177 [23] identifies these six frequencies and establishes that for many cases, including piezoelectric ceramics, one can make the assumption that $f_m = f_s = f_r$ and $f_a = f_p = f_n$. For lossy materials, such as some of the piezoelectric thin films, this assumption can introduce appreciable errors and the six frequencies should be considered separately. The magnitude of the minimum impedance, Z_m , may be determined by substituting an adjustable resistor into the circuit for the ceramic at the previously identified frequency and adjusting the resistance until the voltmeter reading is the same as for the ceramic. Today, fully integrated impedance analyzers are commercially available to make this type of measurement, and even allow the researcher to choose an equivalent circuit model and will report the values of the discrete components of the equivalent circuit along with f_r and f_a . Also, commercial off-the-shelf software is now available which can be used in conjunction with an analyzer to evaluate the impedance information and calculate the relative material properties of a piezoelectric device [26]. These tools can aid the researcher in the evaluation of material properties, however a basic understanding of piezoelectric behavior is an important foundation that should not be overlooked.

Table 1.
Sample geometries for measurement of material properties

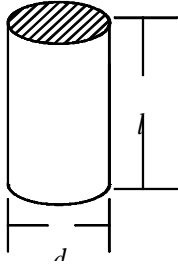
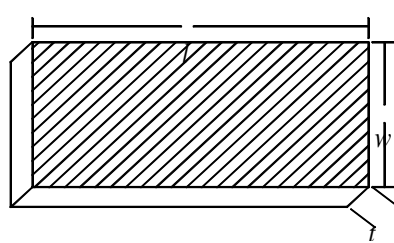
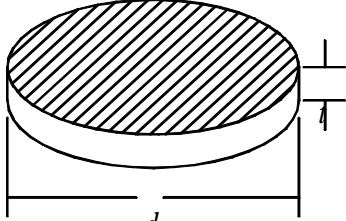
			
Dimensional	long, slender, length	thin, flat plate, thickness poled;	thin flat disc, thickness poled
Requirements	poled rod; $l > 3d$	$l > 3.5 t, w$	$d > 10 t$
Properties	$K_3^T, k_{33}, \tan \delta, s_{33}^D,$	$K_3^T, k_{31}, \tan \delta, s_{11}^D,$	$K_3^T, k_p, \tan \delta, Q_M$
Measured	$s_{33}^E, d_{33}, g_{33}, Q_M$	$s_{11}^E, d_{31}, g_{31}, Q_M$	

3.1.2. **Measurement of material properties.** Capacitance measurements are usually carried out at 1kHz and at low excitation voltages (mV level). Although research has shown capacitance and loss to vary with excitation voltage and frequency [27,28], the 1kHz, low voltage measurement is used in the determination of material properties. The free relative dielectric constant, K^T , is defined as the ratio of the permittivity of the material to the permittivity of free space. It is calculated from the following:

$$K^T = \frac{tC}{\epsilon_0 A} \quad (17)$$

where t is the distance between electrodes in meters, C is the capacitance in farads, ϵ_0 is the permittivity of free space (8.85×10^{-12} F/m), and A is the area of an electrode in meters².

The loss tangent, $\tan\delta$, is defined as the ratio of resistance to reactance in the parallel equivalent circuit of Figure 9a. It is a measure of the dielectric losses in the material and therefore also a measure of the heat generation capacity of the ceramic when operated under dynamic conditions. This is a direct measurement and is usually formed at the same conditions as the capacitance measurement.

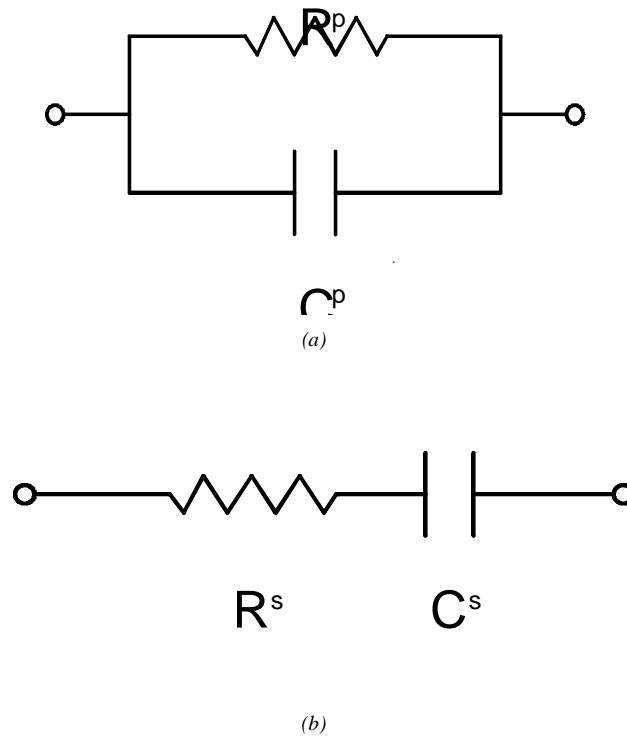

Fig 9. Non-resonant (a) parallel and (b) series equivalent circuit

The three most common coupling coefficients are k_p , k_{31} , and k_{33} ; where the p is for planar, and the 31 and 33 subscripts are for length extensional and thickness extensional modes. The coefficients k_{33} and k_{31} are calculated from the frequencies of minimum and maximum impedance and are given by the equations

$$k_{33}^2 = \frac{\frac{\pi}{2}}{1 + \frac{(f_a - f_r)}{f_r}} \tan \left\{ \frac{\frac{\pi(f_a - f_r)}{2f_r}}{1 + \frac{(f_a - f_r)}{f_r}} \right\} \quad (18)$$

$$k_{31}^2 = \frac{\psi}{1 + \psi} \quad (19)$$

where:

$$\psi = \frac{\pi}{2} \left(1 + \frac{f_a - f_r}{f_r} \right) \tan \left(\frac{\pi(f_a - f_r)}{2f_r} \right) \quad (20)$$

The planar coupling coefficient k_p is defined for thin discs and can be approximated by

$$k_p \approx \frac{f_a^2 - f_r^2}{f_r^2} \quad (21)$$

Elastic compliance is the ratio of a material's change in dimensions (strain) in relation to an externally applied load (stress). This is the inverse of Young's modulus. For a piezoelectric material, the compliance depends on whether the strain is parallel or perpendicular to the poling axis and the electrical boundary conditions. Elastic constants are calculated from the following equations:

$$s_{33}^D = \frac{1}{4\rho f_a^2 l^2} \quad (22)$$

$$s_{33}^E = \frac{s_{33}^D}{1 - k_{33}^2} \quad (23)$$

$$s_{11}^E = \frac{1}{4\rho f_r^2 w^2} \quad (24)$$

$$s_{11}^D = s_{11}^E (1 - k_{31}^2) \quad (25)$$

where ρ is the density of the material in kg/m^3 and l is the distance between electrodes and w is the width of the ceramic. The superscripts D and E stand for constant electric displacement (open circuit) and constant electric field (short circuit) respectively.

The d_{ij} piezoelectric constants, which relate the applied electric field to the strain, can be calculated from the coupling, elastic coefficients and the dielectric constant. They are

$$d_{33} = k_{33} \sqrt{\epsilon_0 K_3^T s_{33}^E} \quad (26)$$

$$d_{31} = k_{31} \sqrt{\epsilon_0 K_3^T s_{11}^E} \quad (27)$$

The g_{ij} piezoelectric constants are related to the d_{ij} coefficients by the following equations:

$$g_{33} = \frac{d_{33}}{\epsilon_0 K_3^T} \quad (28)$$

$$g_{31} = \frac{d_{31}}{\epsilon_0 K_3^T} \quad (29)$$

It should be noted that the piezoelectric coefficients calculated above are only valid at frequencies well below resonance and do not account for any non-linear behavior of the ceramic.

They are not dependent on the dimensions of the material, however they will vary with the degree of polarization of the ceramic. They also do not provide the sign of the coefficient, which must be determined through direct measurements.

The mechanical Q_M , the ratio of reactance to resistance in the series equivalent circuit of Figure 9a is given by:

$$Q_M = \frac{1}{2\pi f_r Z_m C_0} \left(\frac{f_a^2}{f_a^2 - f_r^2} \right) \quad (30)$$

3.2. Direct Methods. Direct measurements of the piezoelectric constants are possible and have been used to quantify the direct and converse effects in ceramic samples. Direct methods are also used to investigate the behavior of the ceramic in regards to hysteresis, non-linearity, frequency response, aging, thermal behavior, and other characteristics that are not resolved by the above methods. These methods typically apply a known input to the ceramic, either an electric field or a force, and record the corresponding output, either a deformation or a charge under various conditions. These methods are in contrast to the bulk material characterization using the electrical resonance techniques described above. Many times, the direct measurements are carried out on a ceramic that has been configured as a sensor or actuator. Typical processing may include electroding, laminating, applying preload, mounting, and other assembly procedures to be able to effectively adapt the material for use as a sensor or actuator. These measurements aid the researcher in modeling the behavior of the piezoelectric device and allow the efficient integration of the devices into real world applications.

Displacement measurements of piezoelectric actuators are performed to determine the magnitude and sign of the relationship between applied electric field and the strain developed, i.e., the converse effect. For a PZT wafer, this corresponds to the d_{ij} coefficient; however for bending type actuators this relationship does not correlate directly to any of the measured properties for out of plane bending using the resonance techniques. Based on equations (10)-(15), it can be seen that for a case where the ceramic is free to expand ($T_k = 0$), then the strain is only a function of the product of the applied field E_i and the d_{ij} coefficient

$$S_j = d_{ij} E_i \quad (31)$$

Careful attention must be paid to the boundary conditions of the ceramic to assure that the above assumption is valid. In a plot of the strain as a function of applied field, the slope yields an average value of d_{ij} . Typically these measurements are made with a non-contacting displacement transducer [29] to reduce the effects of loading on the actuator. Laser based and other optical or capacitive displacement measurement techniques are most commonly used [30-32]. Displacements may range from sub-micron levels for single PZT wafers to the centimeter level for bending type actuators. For very small displacements, an optical-lever type measurement system or interferometric techniques [33] have been used to resolve the displacement of the ceramic. Direct application of either foil or

optical strain gages has also been utilized for measurement of the actuator strain. These measurements may be made either statically or dynamically, depending on the measurement system and the intended application of the ceramic. If dynamic measurements are made, excitation frequencies should be at least an order of magnitude less than any resonant frequency of the device to assure a linear behavior and that the boundary conditions are suitable for the intended measurement.

Another direct method used to measure the piezoelectric constants is based on the direct piezoelectric effect [22,34]. Here, a known load is either applied to or lifted off a ceramic at rest. The resulting charge, which accumulates on the electrodes, is then measured as a voltage across a capacitor in parallel with the ceramic or the current from the ceramic can be integrated directly. If E_i is 0 (short circuit), then equation (2) reduces to:

$$D_i = d_{ij}T_j \quad (32)$$

and knowing the applied stress and measuring the electric displacement, the appropriate d_{ij} coefficient can be found.

If a piezoelectric ceramic is immersed in a liquid and the pressure of the liquid is varied, then the piezoelectric coefficient d_h can be quantified by measuring the voltage on a large capacitor in parallel with the ceramic. This coefficient represents the response of the ceramic to hydrostatic pressure applied equally in all axes. Convention has dictated that for the d_h coefficient, electrodes are perpendicular to the 3-direction. The d_h coefficient is related to the other d coefficients for a ceramic by the equation:

$$d_h = d_{33} + 2d_{31} \quad (33)$$

By varying the frequency of the excitation voltage to the ceramic while measuring the displacement, the frequency response of the device may be obtained. Typical resonant frequencies of bulk ceramic material are in the kilohertz to megahertz range depending on the mode of vibration, while resonant frequencies of bender types (unimorph or bimorph) may be less than 100 hertz. For maximum strain, a piezoelectric actuator can be excited at its natural frequency, however this non-linear behavior must be taken into account if the actuator is to be used over a range of frequencies. Also, careful attention must be paid to the instrumentation system's dynamic response, in both amplitude and phase distortion, when making dynamic measurements. Measurement systems have their own frequency response characteristics which must be separated from the response of the ceramic under test.

Hysteresis is a phenomenon that is present in all piezoelectric materials. Hysteretic behavior is due to the lossy nature of the ceramic where the current trails the applied voltage by an angle α related to the loss tangent of the material. For actuators, this means that the absolute displacement is not only dependent on the excitation voltage and frequency, but also on whether the voltage is increasing or decreasing. To characterize the amount of hysteresis in a ceramic, a sinusoidal voltage is applied to the device and the displacement is recorded. By plotting the displacement vs. driving voltage, as shown in Figure 10, the hysteretic behavior of the ceramic can be observed. The amount of hysteresis (usually expressed in percent) is defined as the largest difference between the maximum and minimum displacement for any voltage divided by the total displacement. Of note in Figure 10 is the fact that as the peak voltage is increased, the amount of hysteresis also increases for any given voltage.

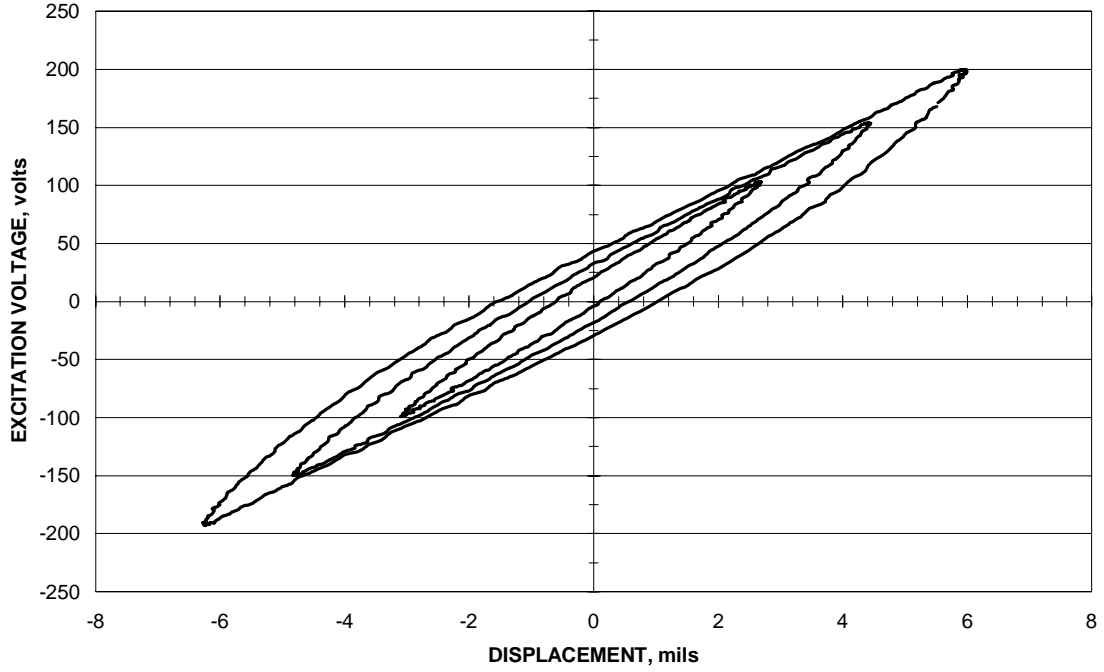

Fig 10. Strain hysteresis of a piezoelectric ceramic unimorph

Generally, piezoelectric ceramic actuators exhibit a decrease in their displacement for a given excitation voltage as they are loaded. This relationship can be seen in equation (3), for the case where $T_k \neq 0$. As the load is increased, the displacement eventually reaches zero and the actuator provides only a force output. This force is known as the blocked force, and it is the maximum amount of force that the actuator can produce at that voltage. To characterize this relationship, the actuator is loaded with a load less than the blocked force and the displacement is measured. If the load is varied, then the force/displacement relationship can be determined (Figure 11). To determine the blocked force, the actuator must be rigidly held so as not to deform, and the force output measured with a load cell or other force-measuring device. Because the displacement of some piezoelectric actuators is quite small, this measurement can be difficult. The blocked force F_B can alternately be calculated by the equations below

$$F_B = \frac{E_3 d_{33} w l}{s_{33}^E} \quad (34)$$

$$F_B = \frac{E_3 d_{31} w t}{s_{11}^E} \quad (35)$$

where E is the applied field, l , w and t are the length, width and thickness of the ceramic, respectively. Equation (34) applies to thickness extensional mode and equation (35) applies to length thickness extensional mode.

Actuators with greater displacements better lend themselves to the blocked force measurement (such as domed pre-stressed actuators or unimorph/bimorph type actuators). The blocked force may also be determined by extrapolating the force/displacement relationship to zero displacement if a true blocked force measurement is not practical. In most applications, actuators will operate somewhere between the free (unloaded) state and the completely constrained state.

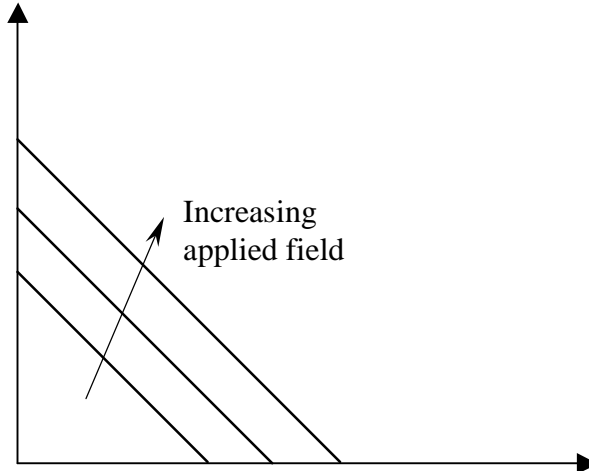

Fig 11. Typical stress/strain relationship for a piezoelectric ceramic

It has been previously reported that a constant preload applied to a piezoelectric actuator can actually increase the displacement of the ceramic as compared to an unloaded specimen [34-36]. This may be a result of simply reducing the compliance or mechanical slope in a PZT assembly or may be a real increase in the d -coefficient. This effect will reach a maximum and then start to cause a decrease in the coefficient as the pre-load is increased up to the blocked force.

Temperature effects on the piezoelectric coefficients of ceramics may also be evaluated. Usually, ceramics must be used well below their Curie temperature to maintain polarization. For hard and soft PZTs, the respective Curie temperatures are on the order of 360°C (680 °F) and 330°C (626°F). For operation at lower temperatures, even down to cryogenic levels, the piezoelectric coefficients generally decrease with decreasing temperature. This effect can be experimentally quantified through either resonance techniques or direct measurements over the desired temperature range [34].

The power required to drive a piezoelectric ceramic can be calculated from the following equation:

$$P = 2\pi f C \tan \delta V_{rms}^2 \quad (36)$$

when the ceramic is modeled as in Figure 9a where f is the driving frequency, C the capacitance, $\tan \delta$ the loss tangent, and V_{rms} the root mean square of the excitation voltage. Typically, both the capacitance and loss tangent of the ceramic are assumed to be constant when using equation (36). Doing so can lead to large errors when estimating the power consumption of a ceramic. To avoid these errors, either the voltage and current supplied to the ceramic should be measured to provide a direct indication of the power consumption, or the variation of capacitance and loss of the material as functions of applied field and frequency must be quantified and incorporated into equation (36) [28]. A number of researchers have investigated the power consumption characteristics of PZT actuators used to excite a host structure [27,37,38] and found a coupling between the mechanical motion of the structure and the electrical characteristics of the piezoelectric actuator. Research by Brennan and McGowan [27] shows that the power consumption of piezoelectric materials used for active vibration control is independent of the coupling effects of the host structure when the structure is *completely controlled*. From these findings, they conclude that the power requirements of the piezoelectric actuator are only dependent upon its geometry and material properties, and the driving voltage and frequency of the control signal. Research [23] has indicated that both capacitance and resistance are non-linear functions of the peak amplitude and frequency of the excitation voltage

With time, piezoelectric effects imparted through poling will degrade. Aging of piezoelectric ceramics, like many other materials, is logarithmic with time. With most ceramics, a return to initial performance levels can be accomplished by simply repoling the sample. Aging levels depend on the composition; the coupling coefficient of soft PZT composition ages at a rate of -1% per time decade versus -2% for a hard composition. Degradation of piezoelectric behavior also depends on the level of stress to which the ceramic is subjected. Large stress levels can lead to switching of the polarization and eventually depoling of the ceramic. Large stresses also induce micro cracking, which can lead to ceramic breakage and failure.

The methods outlined above can be used either separately or together to investigate the dielectric, piezoelectric, and elastic properties of a ceramic. Resonant techniques, which are the preferred method of measurement of the IEEE standard, are easy to implement and the associated frequencies can be measured accurately. There is even commercially available hardware and software available to assist in these measurements and the evaluation of material properties. However, these methods do not explain any non-linear behavior that is present in the ceramic. Dependence of material properties on the frequency and amplitude of the applied voltage are among these non-linear effects. Direct measurements of the piezoelectric constants can quantify the material properties under different operating conditions and provide insight beyond the standard linear behavior predicted by the resonance techniques. These methods though, are usually more rigorous in their requirements of material handling and instrumentation.

3.3. Modeling of Piezoelectric Ceramics. There are a host of applications for piezoelectric materials and despite the fact that they have been studied for over a century, potential for improvement and innovation still persists. Modeling of piezoelectric ceramics and their properties affords a way to accelerate materials improvement and aid in device design and development. For that reason, we would be remiss not to mention it, albeit briefly. This introduction is in no way meant as a comprehensive review of the vast area of modeling of piezoelectricity, however the references cited provide a good starting place. Care must be taken to differentiate between modeling of the piezoelectric material and modeling of a “piezoelectric structure”, where often a piezoelectric material is laminated or adhered to a substrate as a unimorph or bimorph.

A number of researchers experimented with commercial packages such as ANSYS® [39]. However, these commercial packages have limitations. Other groups have written their own codes with varying degrees of success [40-43]. Finite element schemes combining piezoelectric and acoustic elements proved useful in characterizing the electromechanical behavior of piezoelectric transducers [44]. Most of these schemes are restricted in that they assume linearity of the coefficients. Perez et al expanded on these models by including nonlinear elements into the equivalent circuit [45]. Models of the non-linear hysteretic behavior of piezoelectric materials are abundant in the literature, and can be divided based on the dimensional scale they probe. Microscopic models primarily stem from energy relations applied at the atomic or molecular level [46]. Macroscopic models [47-49] often use empirical relations to describe the behavior of the bulk material. Both methods have their advantages and disadvantages; microscopic models require a great number of parameters, often not available, and macroscopic models do not consider the underlying physics. A number of authors proposed a third approach, a meso-scale or semi-microscopic model that combines the advantages of the previous methods, thus allowing a better way to model the hysteretic behavior. This is accomplished by starting out from energy principles applied at the microscopic level, then using a relatively small number of parameters to simulate the behavior of bulk ceramics [50,51].

4. Conclusion. Characterization of the elastic, dielectric and electromechanical properties of piezoelectric ceramics is crucial for several reasons. First, investigations of the material properties provide a link between the manufacturing process and ceramic performance. This enables the developer of the materials to adjust the manufacturing process of the ceramic to produce tailored materials. Second, the engineer can investigate

prospective materials for applicability to a specific need. Also, material parameters obtained through characterization can be used to develop and validate analytical models of the ceramics. Insights gained through characterization have led to many new devices and uses. For example, investigation of the hydrostatic coefficients of PZT and those of the piezoelectric polymer polyvinylidene fluoride, PVDF, identified the product of d_h and g_h as a figure of merit and led to composite research to combine both materials yielding a superior device that better fits underwater and hydrophone applications. More than a century after their discovery, piezoelectric ceramics have become viable for commercial purposes. Researchers continue to diligently uncover novel ways to characterize the complex electromechanical properties and as they do so, new processing methods and applications are revealed. Recently, as an example, researchers at MIT have successfully grown piezoelectric single crystals [52], opening opportunities for newer applications. Published articles on composite processing and characterization have become more abundant as well.

Without question, piezoelectric ceramics have secured a permanent place in the field of material science and engineering.

5. Acknowledgement. The authors express their sincere appreciation to Dr. Jeffrey A. Hinkley (NASA Langley Research Center) for his review of the manuscript and his helpful comments.

REFERENCES

- [1] V. W. VOIGT, *Lehrbuch der kristallphysik*, B. G. Teubner, Leipzig: Berlin, 1910.
- [2] *Œuvres scientifiques de Paul Langevin*, Centre National de la recherche scientifique, 1950.
- [3] W. G. CADY, *Piezoelectricity: An introduction to the theory and applications of electromechanical phenomena in crystals*, Dover Publications: New York, 1964.
- [4] B. JAFFE, W. R. COOK, JR. AND H. JAFFE, *Piezoelectric ceramics*, Academic Press: London, New York, 1971.
- [5] S. B. HERNER, *The use of acceptor dopants to lower the loss tangent in barium strontium titanate*, Thesis: Pennsylvania State University, 1993.
- [6] *Measurement of Properties of Piezoelectric Ceramics*, Sensor Technology Limited, BM91-309, Manufacturer Handbook, 1991.
- [7] A. J. MOULSON AND J. M. HERBERT, *Electroceramics: Materials, properties, applications*, Chapman and Hall: London, New York, 1992.
- [8] Q. F. ZHOU, H. L. W. CHAN, AND C. L. CHOY, *Nanocrystalline Powder and Fibres of Lead Zirconate Titanate Prepared by the Sol-Gel Process*, Journal of Materials Processing Technology, 63, No. 1-3 (1997), pp. 281-285.
- [9] Z. OUNAIES, *Sol-gel and Microwave Processing of PZT Materials for Sensor and Actuator Applications*, the Pennsylvania State University, 1995.
- [10] J. P. WHITMAN, *Hydrothermal Preparation and Fabrication of Lead Zirconate Titanate (PZT) Ceramics*, the Pennsylvania State University, 1993.
- [11] C. NEAR, G. SHMIDT, K. MCNEAL AND R. GENTILMAN, *Injection Molded PZT Actuators*, SPIE 5th Annual Symposium on Smart Structures and Materials Proceedings, 3326 (1998), pp. 323-331.
- [12] L. M. LEVINSON, *Electronic Ceramics: Properties, Devices, and Applications*, General Electric Company: New York, 1988.
- [13] ACX Controls Expert, www.ACX.com.
- [14] C. B. SAWYER AND C. H. TOWER, Phys. Rev., 35 (1930), pp. 269-273.

- [15] M.E. LINES AND A. M. GLASS, *Principles and Applications of Ferroelectrics and Related Materials*, Clarendon: Oxford, 1979.
- [16] Y. XU, *Ferroelectric Materials and Their Applications*, North-Holland: Amsterdam, 1991.
- [17] G. A. SMOLENSKII, V. A. BOKOV, V. A. ISUPOV, N. N. KRAINIK, R. E. PASYNKOV AND A. I. SOKOLOV, *Ferroelectrics and Related Materials*, Gordon and Breach Science Publishers: New York, 1984.
- [18] J. C. BURFOOT, *Ferroelectrics: An Introduction to the Physical Principles*, Van Norstrand: London, 1967.
- [19] ANSI/IEEE std. 180-1986, IEEE Standard Definitions of Primary Ferroelectric Terms, The Institute of Electrical and Electronics Engineers, Inc.: New York, 1986.
- [20] *IEEE Standard on Piezoelectricity*, (IEEE Standard 176-1987); Institute of Electrical and Electronic Engineers, 345 East 47th St, New York, NY 10017.
- [21] S. SHERRIT, H.D. WIEDERICK, AND B.K. MUKHERJEE, *Accurate Equivalent Circuits for Unloaded Piezoelectric Resonators*, IEEE Ultrasonics Symposium Proceedings, pp. 931-935, 1997.
- [22] W. P. MASON AND H. JAFFE, *Methods for Measuring Piezoelectric, Elastic, and Dielectric Coefficients of Crystals and Ceramics*. Proceedings of the IRE, 42 (1954), pp. 921-930.
- [23] *IEEE Standard Definitions and Methods of Measurement for Piezoelectric Vibrators*, (IEEE Standard 177-1966); Institute of Electrical and Electronic Engineers, 345 East 47th St., New York, NY 10017.
- [24] K. W. KWOK, H. L. CHAN AND C. L. CHOY, *Evaluation of the Material Parameters of Piezoelectric Materials by Various Methods*, IEEE Trans. On Ultrasonics, Ferroelectrics and Frequency Control, 44, No. 4 (1997), pp. 733-742.
- [25] *Procedures for Measuring Properties of Piezoelectric Ceramics*, Morgan Matroc Inc., Technical Publication, TP-234.
- [26] *Piezoelectric Resonance Analysis Program*, TASI Technical Software, 1996.
- [27] M. C. BRENNAN AND A. M. MCGOWAN, *Piezoelectric Power Requirements for Active Vibration Control*, SPIE 4th Annual Symposium on Smart Structures and Materials Proceedings, 3039 (1997), pp. 660-669.
- [28] T. JORDAN, Z. OUNAIES, J. TRIPP AND P. TCHENG, *Electrical Properties and Power Considerations of a Piezoelectric Actuator*, Materials Research Society Symposia Proceedings, 604 (2000), pp. 203-208.
- [29] J. T. DAWLEY, G. TEOWEE, B. J. J. ZELINSKI AND D. R. UHLMANN, *Piezoelectric Characterization of Bulk and Thin Film Ferroelectric Materials Using Fiber Optics*, MTI Instruments Inc, Application Note, www.mtiinstruments.com/appnotes/piezo.htm, September 2001.
- [30] W. Y. PAN, H. WANG AND L. E. CROSS, *Laser Interferometer for Studying Phase Delay of Piezoelectric Response*, Jpn. J. Appl. Phys., 29 (1990), p. 1570.
- [31] Q. M. ZHANG, W. Y. PAN AND L. E. CROSS, *Laser interferometer for the study of piezoelectric and electrostrictive strains*, J. Appl. Phys., 63 (1988), p. 2429.
- [32] T. L. JORDAN, Z. OUNAIES AND T. L. TURNER, *Complex Piezoelectric Coefficients of PZT Ceramics: Method for Direct Measurement of d_{33}* , Materials Research Society Symposia Proceedings, 459 (1997), p. 231.
- [33] H. D. WIEDERICK, S. SHERRIT, R. B. STIMPSON AND B. K. MUKHERJEE, *An Optical Lever Measurement of the Piezoelectric Charge Coefficient*, 8th European Meeting on Ferroelectricity Proceedings, Nijmegen, The Netherlands, July 4-8, 1995.
- [34] S. SHERRIT, R. B. STIMPSON, H. D. WIEDERICK AND B.K. MUKHERJEE, *Stress and Temperature Dependence of the Direct Piezoelectric Charge Coefficient in Lead Zirconate Titanate Ceramics*, SPIE Far East and Pacific Rim Symposium on Smart Materials, 3321 (1996), pp. 74-81.

- [35] H. H. A. KRUEGER AND D. BERLINCOURT, *Effects of High Static Stress on the Piezoelectric Properties of Transducer Materials*, Journal of the Acoustical Society of America, 33, No. 10 (1961), pp. 1339-1344.
- [36] The Piezo Book, Burleigh Instruments Inc., Piezo 330 692, Manufacturer Handbook, 14 pp.
- [37] S. C. STEIN, C. LIANG AND C. A. ROGERS, *Power consumption of piezoelectric actuators driving a simply supported beam considering fluid coupling*, J. of the Acoustical Society of America, 96 (1994), pp. 1598-1604.
- [38] C. LIANG, F. P. SUN AND C. A. ROGERS, *Coupled Electro-Mechanical Analysis of Adaptive Material Systems-Determination of the Actuator Power Consumption and System Energy Transfer*, J. of Intelligent Mater. Syst. and Struct., 5 (1994), pp. 12-20.
- [39] ANSYS/Multiphysics software, ANSYS, Inc. Southpointe 275 Technology Drive, Canonsburg, PA 15317.
- [40] Y. KAGAWA AND T. YAMABUCHI, *Finite Element Simulation of Two-Dimensional Electromechanical Resonators*, IEEE Trans. Sonics Ultrason., SU-21 (1974), pp. 275-283.
- [41] R. LERCH, *Modern Techniques in Electroacoustic Transducer Development*, Proc. 9th Conf. Acoustics, Budapest, Hungary, 1988.
- [42] D. F. OSTERGAARD AND T. P. PAWLAK, *Three-dimensional Finite Elements for Analysing Piezoelectric Structures*, Proc. IEEE Ultrason. Symp., Williamsburg, VA, pp. 639-642, 1986.
- [43] R. LERCH, *Simulation of Piezoelectric Devices by Two- and Three-Dimensional Finite Elements*, IEEE Transactions on Ultrasonics, Ferroelectrics, and Frequency Control, 37, No. 2 (1990), pp. 233 –247.
- [44] R. SIMKOVICS, H. LANDES, M. KALTENBACHER AND R. LERCH, *Nonlinear Finite Element Analysis of Piezoelectric Transducers*, IEEE Ultrasonics Symposium, pp. 1057-1060, 1999.
- [45] R. PEREZ, E. MINGUELLA AND J. A. GORRI, *Weak Nonlinearities in Piezoelectric Transducers: Equivalent Circuits*, Proceedings of the 11th IEEE International Symposium on Applications of Ferroelectrics (ISAF), pp. 247 –250, 1998.
- [46] M. OMURA, H. ADACHI AND Y. ISHIBASHI, *Simulations of Ferroelectric Characteristics Using a One-Dimensional Lattice Model*, Japanese Journal of Applied Physics, 30 (1991), pp. 2384-2387.
- [47] W. S. GALINAITIS AND R. C. ROGERS, *Compensation for Hysteresis using Bivariate Preisach models*, SPIE Smart Structures and Materials: Mathematics and Control in Smart Materials, San Diego, CA, 1997.
- [48] P. GE AND M. JOUANEH, *Modeling Hysteresis in Piezoceramic Actuators*, Precision Engineering, 17 (1995), pp. 211-221.
- [49] X. D. ZHANG AND C. A. ROGERS, *A Macroscopic Phenomenological Formulation for Coupled Electromechanical Effects in Piezoelectricity*, Journal of Intelligent Material Systems and Structures, 4 (1993), pp. 307-316.
- [50] W. CHEN AND C. S. LYNCH, *A Model for Simulating Polarization Switching and AF-F Phase Changes in Ferroelectric Ceramics*, Journal of Intelligent Material Systems and Structures, 9 (1998), pp. 427-431.
- [51] R. C. SMITH AND Z. OUNAIES, *A Domain Wall Model for Hysteresis in Piezoelectric Materials*, Journal of Intelligent Material Systems and Structures, 11, No. 1 (2000), p. 62.
- [52] A.N. SOUKHOJAK, H. WANG, G.W. FARREY AND Y.-M. CHIANG, *Superlattice in Single Crystal Barium-Doped Sodium Bismuth Titanate*, J. Phys. Chem. Solids, 61, No. 2 (2000), pp. 301-304.