



Printed on recycled paper.



Science and Technology Review  
Lawrence Livermore National Laboratory  
P.O. Box 808, L-664  
Livermore, California 94551

# Science & Technology

REVIEW

March 1996

Lawrence  
Livermore  
National  
Laboratory



## Laying the Scientific Groundwork for the Safe Disposal of Nuclear Waste

Also in this issue:

- The Diamond Anvil Cell
- Hydrogen Fuel Infrastructure

Nonprofit Org.  
U. S. Postage  
**PAID**  
Livermore, CA  
Permit No. 154

144+00



## About the Cover

The safe, long-term disposal of nuclear waste has been a concern of Laboratory scientists for many years. The artist's rendering on this month's cover shows one concept of a nuclear waste repository deep within the earth, complete with a remotely controlled storage and retrieval system, multiple storage chambers, and waste packaging systems to protect the environment from radioactive contamination. The article beginning on p. 6 reports on Laboratory work on the engineered barrier system at the heart of the planned repository. Dating from 1977, this work has focused on testing and selecting materials for the manmade waste package as well as on modeling the long-term interactions of the waste and the waste package with the near-field geological environment to assure the safety of human life and the environment for 10,000 years.



Cover rendering: John Maduelli

## What Do You Think?

We want to know what you think of our publication. Please use the enclosed survey form to give us your feedback.

## Electronic Access

*S&TR* is available on the Internet at <http://www.llnl.gov/str/str.html>. As references become available on the Internet, they will be interactively linked to the footnote references at the end of each article. If you desire more detailed information about an article, click on any reference that is in color at the end of the article, and you will connect automatically with the reference.

## About the Review

The Lawrence Livermore National Laboratory, operated by the University of California for the United States Department of Energy, was established in 1952 to do research on nuclear weapons and magnetic fusion energy. *Science and Technology Review* (formerly *Energy and Technology Review*) is published monthly to communicate, to a broad audience, the Laboratory's scientific and technological accomplishments, particularly in the Laboratory's core mission areas—global security, energy and the environment, and bioscience and biotechnology. The publication's goal is to help readers understand these accomplishments and appreciate their value to the individual citizen, the nation, and the world.

Please address any correspondence (including name and address changes) to *S&TR*, Mail Stop L-664, Lawrence Livermore National Laboratory, P.O. Box 808, Livermore, California 94551, or telephone (510) 422-8961. *S&TR* is also available on the Internet at <http://www.llnl.gov/str/str.html>, and our electronic mail address is [hunter6@llnl.gov](mailto:hunter6@llnl.gov).

## S&TR Staff

**SCIENTIFIC EDITOR**  
Becky Failor

**PUBLICATION EDITOR**  
Dean Wheatcraft

**WRITERS**  
Kevin Gleason, Robert D. Kirvel,  
Jeff Sketchley, Dale Sprouse,  
Katie Walter, and Dean Wheatcraft

**ART DIRECTOR**  
Ray Marazzi

**DESIGNERS**  
George Kitrinis and Ray Marazzi

**GRAPHIC ARTISTS**  
Treva Carey, Paul Harding, and  
Kathryn Tinsley

**COMPOSITOR**  
Louisa Cardoza

**PROOFREADERS**  
Jill Sprinkle and  
Catherine M. Williams

*S&TR* is produced by the Technical Information Department as a service for the Director's Office.

Printed in the United States of America

Available from  
National Technical Information Service  
U.S. Department of Commerce  
5285 Port Royal Road  
Springfield, Virginia 22161

UCRL-52000-96-3  
Distribution Category UC-700  
March 1996

This publication is a continuation of  
*Energy and Technology Review*.

# Science & Technology REVIEW

March 1996

Lawrence  
Livermore  
National  
Laboratory

2 The Laboratory in the News

4 Commentary on Industrial Ecology

### Features

6 The Safe Disposal of Nuclear Waste

A system of multiple engineered and geological barriers deep within the earth may contain the nation's accumulating stores of radioactive nuclear waste.

17 The Diamond Anvil Cell: Probing the Behavior of Metals under Ultrahigh Pressures

The Laboratory's diamond anvil cell can compress tiny samples of weapons-related materials to ultrahigh pressures equal to those at the center of the Earth, allowing researchers to study changes in the properties of these materials that can affect weapons performance.

### Research Highlight

28 Getting Along without Gasoline—The Move to Hydrogen Fuel

32 Patents

33 Abstracts

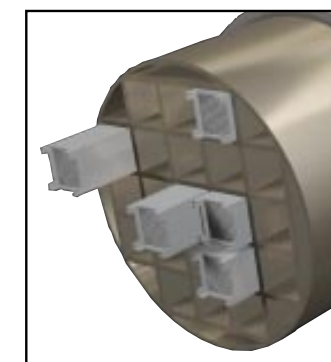

Page 6



Page 17



Page 28



Prepared by LLNL under contract  
No. W-7405-Eng-48

### Detailed design begins on NIF

Detailed engineering design is now under way on the National Ignition Facility, a proposed 192-beam laser system that President Bill Clinton and Energy Secretary Hazel O'Leary have cited as a key tool for stewardship of the nation's nuclear weapons stockpile. When operational, NIF will be able to provide data on high temperature and density processes in nuclear weapons that had previously been available only through nuclear testing. This data will be used to evaluate changes in stockpiled weapons due to aging or remanufacture and to verify computer models that predict weapon reliability.

Earlier this year, the Laboratory signed a contract with Ralph M. Parsons, the architecture and engineering firm chosen to work on design of the facility. Also signed was a Master Task Agreement for engineering services with four firms: SAIC, TRW, Physics International, and Westinghouse.

The next milestone for NIF will come in August or early September, with completion of the environment impact assessment process and formal selection of a site for NIF. The Laboratory was designated in 1994 as the preferred site for the facility.

Contact: Bill Hogan (510) 422-1344 (bill-hogan@llnl.gov).

### Lab, French researchers team on guide star studies

Lab scientists collaborated with French researchers in January to create a powerful laser guide star in the late night skies over Livermore. The purpose of this series of experiments was to refine the use of guide star technology for astronomical observation.

Laser guide stars are used in conjunction with adaptive optics to counteract atmospheric distortion and give astronomers a clear view of the heavens. The laser creates an artificial star in the upper atmosphere. A deformable mirror that adjusts 50 times per second compensates for constantly changing atmospheric conditions. It is linked by computer to the image of the guide star. When the adaptive optics system "focuses" the guide star to a sharp image, the other heavenly bodies in the telescope's field of view can be seen clearly without atmospheric turbulence.

Pioneering work by Livermore scientists and others over the last few years has generally focused on a single wavelength beam. The French experiment involved a dual-frequency beam (569 and 589 nanometers) and used one of the world's most

powerful lasers, a copper/dye laser at Livermore that is part of the AVLIS (Atomic Vapor Laser Isotope Separation) facility.  
Contact: Herb Friedman (510) 422-2257 (friedman3@llnl.gov).

### Lab evaluates new environmental technologies

Under an agreement between the Laboratory and the California Environmental Protection Agency (Cal/EPA), Livermore's scientists and engineers are helping the state evaluate new environmental technologies in hazardous waste management, site cleanup, waste minimization, and pollution prevention.

Signed December 5, 1995, the Memorandum of Agreement provides the state with the services of skilled Lab personnel and unique Lab facilities to assess new environmental technologies seeking certification under California's Environmental Technology Certification Program.

James M. Strock, California Secretary for Environmental Protection, said his agency "sought the services of the Lab because it has highly qualified, specialized, unique, and independent expertise not available in the public or private sector."

In 1993, the state created the California Environmental Technology Partnership to promote research, development, commercialization, and export of California-based environmental technology, goods, and services. The Environmental Technology Certification Program was established to provide one-stop scientific and engineering evaluation of new technologies to encourage their development and speed their acceptance.

Contact: Richard Ragaini (510) 423-8877 (rragaini@llnl.gov).

### Lab scientists probe properties of iron at Earth's core

Using the heating power of a laser and the force of a diamond anvil, Lab scientists are studying the properties of iron at the center of the Earth. By firing a laser beam at iron compressed in a diamond anvil cell, researchers hope to learn with greater precision than before how iron behaves at the extremely high temperatures and pressures at the Earth's center.

The new method has allowed scientists for the first time to determine the melting curve of iron directly by x-ray diffraction *in situ* at high pressure and temperature conditions. Results of the team's experiments have potential industrial applications for the synthesis of new advanced materials, as well as implications for nuclear weapons work.

Previous estimates were based on computer models of core conditions, making the melting curve of iron a "highly controversial issue," according to Choong-Shik Yoo, principal investigator on the core team. "People have been studying this for 30 to 40 years," he says, "but only now are scientists looking at crystal structures at extreme temperatures and pressures. This leaves open the possibility that a new, previously unrecognized phase will be found, the phase explaining what the Earth's core is really made of."

Contact: Choong-Shik Yoo (510) 422-5848 (yoo@llnl.gov).

### Developmental work continues on dymalloy

The Laboratory has entered into a small business Cooperative Research and Development Agreement (CRADA) with Spectramat of Watsonville, California, to demonstrate proof of manufacturability for a "reasonable price" of dymalloy, a mixture of diamond powder and silver alloy. When used as a substrate material in high-power density packaging, dymalloy removes heat much more efficiently than present substrate materials, enabling components to run cooler and at higher power.

The Laboratory had been developing dymalloy with Sun Microsystems under a CRADA, which has since been completed. John Kerns, a member of the dymalloy team, said the material currently costs approximately \$200 for a 10- by 10- by 0.1-centimeter substrate. "We think we can make it for less than that," he said.

Contact: John Kerns at (510) 422-9586 (kerns1@llnl.gov).

### Tarter appoints three senior managers

David M. Cooper, Wayne Shotts, and Jeffrey Richardson have been appointed to key senior management positions at the Laboratory.

Cooper and Shotts were named late last year by Director Bruce Tarter as associate directors—Cooper as AD for Computation and Shotts as AD for Non-Proliferation, Arms Control, and International Security. In January, Tarter named Richardson to the post of director of Communications.

Cooper moved to Livermore from the NASA-Ames Research Center. He held a variety of assignments at NASA-Ames, which he joined in 1962: research scientist, chief of the Computational Chemistry Branch, deputy for the

Aerophysics Directorate, chief of the Numerical Aerodynamic Simulation Systems Division, and, most recently, director of Information Systems.

Shotts joined Livermore in 1974 and has held positions as nuclear weapon designer and group, program, and division leader. Prior to his selection as AD, he was the principal deputy associate director for Defense and Nuclear Technologies. In 1990, in recognition of his pioneering work in advanced and innovative nuclear weapon design, Shotts received the prestigious E. O. Lawrence Award for National Security.

Richardson, who is responsible for leading the formulation and coordination of Laboratory institutional communications, came to the Laboratory from Glaxo-Wellcome, the world's largest pharmaceutical firm, where he was the vice president for Public Affairs. He has held similar positions in other health-related firms and in the banking industry, including supervising Wall Street communications.

Contact: LLNL Media Relations (510) 422-4599.

### Soil cleanup at gasoline spill site declared complete

Environmental regulatory agencies have declared soil cleanup above the water table complete at an underground gasoline spill at the Laboratory. This is the first formal regulatory closure of a nonexcavation cleanup activity at the Lab's Livermore site since cleanup began in 1988.

The area declared "restored" lies where an underground gasoline storage tank leaked into the ground a number of years ago. The gasoline contamination probably occurred gradually during the '60s and '70s. It originated from an old fueling station no longer in existence.

To clean up the spill, Lab scientists employed a combination of innovative technologies, including adaptive pumping, vapor extraction, and underground steaming and electrical heating. During a five-year cleanup, scientists removed more than 37,800 liters (10,000 gallons) of gasoline from groundwater and unsaturated sediments. Most of the gasoline was removed in 1993 through vapor extraction during underground steaming and electrical heating—a process called dynamic underground stripping.

Contact: Albert Lamarre (510) 422-0757 (lamarre1@llnl.gov).

# Primer on Industrial Ecology



**Brad Allenby**  
Director of Energy and  
Environmental Systems

**I**N 1994, *Framing the Laboratory's Future*<sup>1</sup> established three strategic directions for the Laboratory: (1) global security, (2) biosciences, and (3) global ecology. Conceptually, the first two directions are relatively clear: the Laboratory's history of research, funding, and organizational structure provides the intellectual, disciplinary, and institutional context within which they are understood.

Global ecology, however, is fundamentally different. It is not intended to mean simply, or even primarily, the study of biological communities around the globe, which is the realm of traditional ecology. Rather, it refers to the rather broad vision of harmonizing the economy with the environment. There is no context for this, either internal or external. We must build the field itself—the institutions, disciplinary structures, and organizational understanding that must underlie it.

At the risk of understating the obvious, this vision presents the Laboratory with a unique and exciting challenge. In beginning to meet it, we have chosen to base our activities on the nascent field of industrial ecology, which is increasingly accepted as the multidisciplinary field within which such issues will be addressed.<sup>2</sup>

We must understand that the industrial ecology approach is not just an incremental shift in existing environmental approaches. Rather than focusing on local and obvious environmental problems as our society does today, the approach aims at integrating environmental considerations into every aspect of human economic activity. The desired outcome is an evolving economy that is both environmentally and economically efficient and capable of being maintained indefinitely within global environmental constraints. Environmental considerations are therefore not treated as “overhead”—problems to be dealt with only after productive activities are already planned or completed. Rather, they are recognized as strategic to individuals, private firms, and society as a whole.

The implications of this shift are substantial. Experience at firms such as AT&T, IBM, Xerox, and Hewlett-Packard, where industrial ecology is being implemented, demonstrates that the

primary organizations involved are research laboratories; process, product, and manufacturing engineering teams; and even the chief financial officer's organization for developing a “green accounting system.” This experience also demonstrates that, rather than dominating environmental issues as they do now, the traditional environmental and safety personnel of a firm play a secondary, albeit important, information provision role. Similarly at the national level, the lead in industrial ecology activities is being assumed by the Department of Energy, a technologically sophisticated organization, rather than by the Environmental Protection Agency, which is responsible for traditional environmental activity. These evolving institutional patterns should not surprise us; indeed, they are simply organizational indicators of the transition of environmental concerns from overhead to strategic.

Taken alone, these evolving practices do not provide an entirely satisfactory alternative to the original *ad hoc* approach to environmental impacts and their mitigation. A more systematic and comprehensive framework must be developed if the goal is not just cleanup but environmental and economic efficiency. Luckily, existing efforts in industrial ecology have helped generate a simple but useful conceptual framework within which we can begin to structure a research agenda (see the [box on p. 5](#)).

Establishing an overall research agenda for the field within the context of the framework is being addressed in a project supported by the Laboratory and involves the Vishnus (a group composed of the nation's leading experts in industrial ecology).<sup>3</sup> Their working model integrates links in the industrial ecology model. In all cases, the key is a systems-based approach that looks at each analytical unit not just by itself, but in the context of its economic and cultural role and over its life cycle.

Two articles in this issue illustrate some of these points in an interesting way. The article on the safe disposal of nuclear waste implicitly shows the problems that arose when a complex technological system—in this case, the production of energy from nuclear fission—was not evaluated over its life cycle before being implemented. At the time nuclear power was initially commercialized, we as a society assumed that the environmental impacts could be dealt with as they arose—that they were overhead. This was not the case, and the social failure to engineer the system as a whole as it was introduced played a large part in the subsequent political reaction against nuclear power—with which we are all familiar. The lesson has been controversial and expensive.

Compare this case history with the approach suggested by the article on moving to hydrogen fuels, a part of the “decarbonization” of the energy economy. Here, the thrust is to understand the systems implications of a transition to a “hydrogen energy economy” before it is encouraged by public policy. While this project is just a first effort, it represents an important conceptual advance. We are also seeking to establish the principle that, before encouraging or funding fundamental shifts in important technological systems, our society should make every effort to model and understand the potential environmental, economic, and technological implications. For example, much of the controversy over the all-electric car mandated by the State of California might have been avoided by just such a study.

Overall, both the industrial ecology initiative by the Laboratory and these articles taken together suggest that we are, in fact, learning to do things better as we face an increasingly environmentally constrained world. The superficial simplicity of the concept of achieving economic and environmental efficiency should not blind us, however, to our current ignorance or to the challenges that lie before us.

## References

1. *Framing the Laboratory's Future: A Vision for Lawrence Livermore National Laboratory*, Lawrence Livermore National Laboratory, Livermore, CA, UCRL-AR-11732 (June 1994).
2. Suggested Reading List  
B. R. Allenby and D. J. Richards, eds., *The Greening of Industrial Ecosystems* (National Academy Press, Washington, DC, 1994).  
T. E. Graedel and B. R. Allenby, *Industrial Ecology* (Prentice-Hall, Upper Saddle River, NJ, 1995).  
*IEEE White Paper of Sustainable Development and Industrial Ecology*, issued by the Environment, Health and Safety Committee of the Institute of Electrical and Electronics Engineers, Inc. (1995).  
R. Socolow, C. Andrews, F. Berkhout, and V. Thomas, Eds., *Industrial Ecology and Global Change* (Cambridge University Press, Cambridge, 1994).
3. The Vishnus, named after the Hindu god also known as “The Preserver,” include Dave Allen of the University of Texas, Brad Allenby of Lawrence Livermore National Laboratory, Jesse Ausubel of Rockefeller University, Bob Ayers of INSEAD, Daryl Banks of the World Resources Institute, Faye Duchin of New York University, Reid Lifset of Yale University, John Ehrenfeld of Massachusetts Institute of Technology, Bob Frosch of Harvard University, Tom Graedel of AT&T, Bruce Guile of the National Academy of Engineering, Dave Rejeski of the Office of Science and Technology Policy, and Rob Sokolow of Princeton University.

## An Agenda for Industrial Ecology

Many projects at the Laboratory already contribute to the development of the field of industrial ecology, to the industrial ecology infrastructure, and, in specific instances, to sectorial and immediate research needs and initiatives. But without an intellectual framework within which to operate, we all will have difficulty in avoiding confusion and achieving—and measuring—meaningful progress. Although simple, the accompanying figure shows where our role in industrial ecology begins.

Industrial ecology—the science of sustainability—is the objective, multidisciplinary study of industrial and economic systems and their linkages with fundamental natural systems. It provides the theoretical scientific basis for understanding and reasoned improvement of current practices. The necessary infrastructure includes legal and economic structures, methodologies and tools, and data and information resources that society must provide to individuals, firms, and other organizations to support their implementation of industrial ecology.

The next level of the system is where current applications of industrial ecology principles are just beginning. This level includes activities in a number of sectors. In manufacturing, for example, development and application of “design for environment” methodologies are advancing rapidly among electronics and automotive manufacturing firms. Similar development and deployment are paralleled in agriculture by activities involving integrated pest management. This level also includes research programs targeted at developing important components of the industrial ecology infrastructure, some of which are already under way.

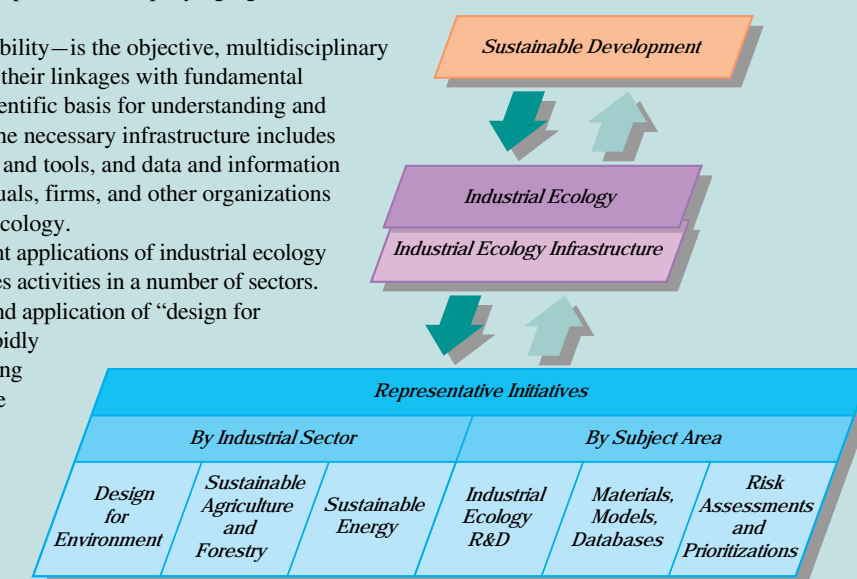

# The Safe Disposal of Nuclear Waste

*Disposing of radioactive nuclear waste is an urgent problem that requires a permanent solution. An engineered barrier system that the Laboratory is developing for a deep underground repository could provide that solution. Our models to predict performance are providing confidence that this system will protect future generations and the environment from harm for tens of thousands of years, until the material is no longer hazardous.*

**M**ORE than 20,000 metric tons of spent fuel from commercial nuclear power plants are located in temporary storage at 109 reactors across the U.S. By the year 2010, about 63,000 metric tons of spent fuel from nuclear power plants and 8,000 metric tons of solidified nuclear waste from defense programs will require permanent disposal.

Most plants store the spent fuel in pools of water, which acts as a radiation shield and coolant. A few plants store spent fuel above ground in special concrete or steel casks. Both types of storage are temporary, and the storage pools at some plants are almost full.

The U.S. is not the only country facing the disposal issue. Around the globe, virtually all nations that use

nuclear power are exploring approaches to safely dispose of radioactive waste.

In the U.S., the pace and focus of research leading to a permanent nuclear waste repository have changed over time in response to shifting political influences and funding. In 1982, Congress passed the Nuclear Waste Policy Act (see [Table 1](#) for other key events). This act made the DOE responsible for finding a suitable site and for building and operating an underground nuclear waste repository. In 1987, Congress directed the DOE to focus on one site, at Yucca Mountain, Nevada, about 145 km northwest of Las Vegas ([Figure 1](#)). As part of the overall effort leading to a permanent nuclear waste repository, Lawrence Livermore's focus is on developing a system of

engineered barriers surrounded by natural ones to contain the highly radioactive waste.

## Containment Objectives

Regardless of what site is eventually approved, a permanent repository for nuclear waste must comply with many federal, health, and safety regulations as well as extensive technical requirements. A key criterion is for essentially complete containment of nuclear waste for 300 to 1,000 years after permanent closure of the repository. Following that containment period, the release per year of any radionuclide (specific nuclear species) from the system cannot exceed 1 part in 100,000 of the radionuclide inventory present 1,000 years following closure. This rate cannot be exceeded for at least 10,000 years.

Such rigid expectations for a man-made system are unprecedented in history. For perspective, 10,000 years is the interval since the end of the last Ice Age, and the great pyramid of Cheops is less than half as old as that.

According to Environmental Protection Agency standards, the radioactive material remaining in nuclear waste at the end of 10,000 years would lead to health effects about the same in number as those associated with an unmined deposit of uranium ore of comparable size. Regulations state that a repository can cause no more than 1,000 health effects (namely cancer) to 10 billion people over 10,000 years.

The disposal problem is urgent, and we do not have much knowledge of how modern materials placed in a geological

site and subjected to initially high temperatures and radiation will behave during thousands of years. Scientists obviously do not have a hundred centuries to validate a system. Thus, much of our development work at Livermore is based on predictive models and accelerated-age testing of materials and systems intended to delay the effects of water and other processes. Our overall task is essentially one of risk assessment.

## The Laboratory's Role

Our current responsibility is focused on the engineered barrier system for an underground repository. This system includes the containers that will hold the waste and a complex series of interactions of the waste form and manmade waste package with the immediate or near-field environment.

**Table 1.** Summary of events leading to a nuclear waste repository. Some LLNL contributions are included for historical perspective.

1957	National Academy of Sciences recommends disposal in rock deep underground.
1963	Salt formations (vaults) studied as potential sites.
1975	Regional studies conducted in 36 states.
1977	LLNL begins research on issues related to disposal.
1979	Yucca Mountain identified as a highly promising repository site.
1982	LLNL begins to systematically survey candidate materials for the waste package.
1982	Congress passes the Nuclear Waste Policy Act.
1983	Nine potential disposal sites studied in six states.
1984	Three sites identified as leading candidates.
1987	Congress directs DOE to study only Yucca Mountain.
1989	Prototype field tests by LLNL and others at G-Tunnel near Yucca Mountain.
1995	Tunnel boring under way for Exploratory Studies Facility over 3 km within Yucca Mountain. Testing and licensing to continue for at least ten years.
1996	DOE considers a Waste Isolation Strategy emphasizing both engineered and natural barrier systems.
2010	Projected deposition of waste at a licensed repository.
2110	Performance period. The Nuclear Waste Policy Act stipulates that the drifts of the licensed repository remain accessible for at least 100 years so that waste may be reclaimed if necessary and performance of the containment systems can be monitored.

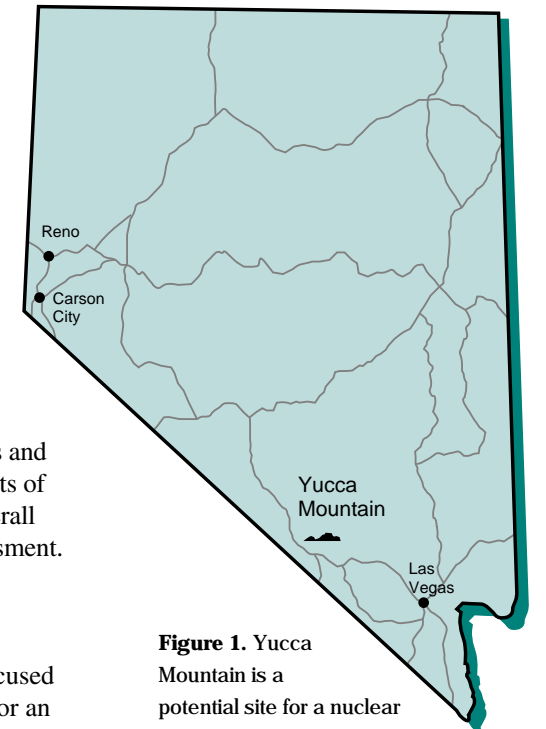

**Figure 1.** Yucca Mountain is a potential site for a nuclear waste repository. It is located in an uninhabited region of Nevada west of the Nevada Test Site.

Our efforts date back to 1977 and now include the contributions of chemists, engineers, geologists, mathematicians, metallurgists, computer modelers, nuclear engineers, and physicists.

The system of manmade and geological barriers that will isolate nuclear waste can be envisioned as a set of concentric cylinders. Figure 2 shows a cross section of an underground repository with the waste, such as spent nuclear fuel, in the center. Moving outward, the following layers of engineered and natural barriers will help

defend against the release of radioactivity:

- A robust waste package consisting of multiple containment barriers, each with a different but complementary purpose. We are studying various metal and alloy disposal containers that will surround either canisters or uncanistered designs.
- An engineered repository system of diffusion barriers, which may include

packing materials around the waste package and backfill around the packing.

- The near-field environment, which can extend several hundred meters into the surrounding rock. Natural barriers, such as zeolitic rocks with high sorption capacity, can slow the migration of radionuclides.
- The far-field environment, which also can slow the migration of radionuclides. An arid climate with low precipitation, high evaporation, and no ground saturation will minimize the transport of radionuclides by water.

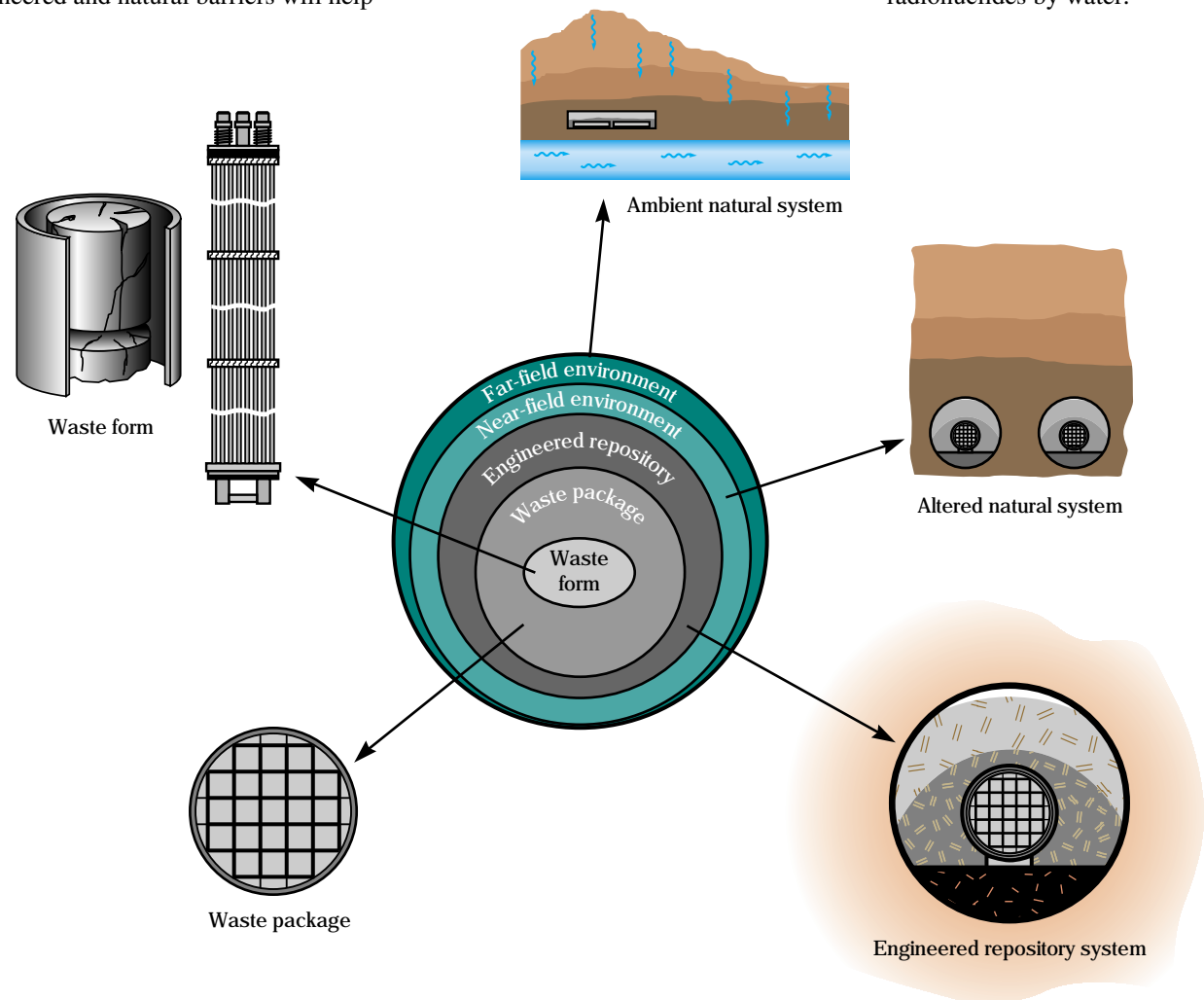

**Figure 2.** The performance of a nuclear waste repository depends on a system of manmade and natural barriers that will delay the release of radionuclides over thousands of years. LLNL's primary responsibilities include selecting materials for the waste package and assessing interactions with the near-field environment extending several hundred meters into the rock.

Our tasks can be broken down into four major areas: characterizing the waste itself, evaluating materials for the waste package, defining the near-field environment, and analyzing the long-term performance of barrier systems. According to project leader Bill Clarke, LLNL researchers have made tremendous progress on all fronts.

### Why Water Is Important

Water is a major concern because of possible corrosion of waste packages and because water can dissolve and transport radionuclides. An important issue is how the heat generated by nuclear waste will mobilize any available water in the vicinity and where that water will go.

Elevated rock temperatures can be advantageous because heat acts as a barrier in a repository. Heat dries nearby rock and keeps moisture away. (See the box at the right.) Locating a repository well above the water table will further minimize container corrosion, leaching, and transport of radionuclides. The series of engineered barriers combined with natural barriers shown in Figure 2 will further delay interactions with water. Through the cumulative effects of these and other factors, we can delay the transport of radionuclides by water for perhaps tens of thousands of years according to our current models. During that time span, the radioactivity of the waste will decay to low levels—to about one-ten-thousandth of the original levels of radioactivity, or less.

Scientists elsewhere are studying the potential for earthquakes, fault movement, and volcanic activity; the effects of possible climate changes; and the potential for unacceptable environmental, social, economic, or transportation-related risks. Licensing of a repository depends on the outcome of these and many other studies.

### What Is Repository Waste?

Nearly 90% of the waste at a permanent repository will be spent fuel from nuclear reactors. Reactor fuel for nuclear power plants consists of solid pellets of enriched uranium oxide sealed in cladding of corrosion- and heat-resistant zirconium alloy. The tubes are bundled to form a nuclear fuel assembly, and the fuel is used for 3 to 5 years, until it no longer efficiently generates heat. Spent fuel assemblies weigh 230 to 550 kg, depending on the type of reactor from which they come. The inventory consists of fission

products with a half-life that is generally less than 100 years and actinides with half-lives of many thousands of years. A permanent repository will store the fuel assemblies and associated hardware.

About 10 to 15% of the repository waste will be high-level waste generated by defense programs. This waste is a mixture of byproducts containing highly radioactive fission products, traces of uranium and plutonium, and other transuranic elements. Before permanent disposal, this waste will be vitrified, that is, converted into a borosilicate glass.

### A Way to Keep Waste Dry with Its Own Heat

At the November 1995 annual meeting of the Materials Research Society in Boston, Lawrence Livermore scientists unveiled a promising approach for storing nuclear waste containers at a potential national repository at Yucca Mountain, Nevada.\* The system would use the heat given off by waste storage containers to produce a dry environment that could keep thousands of tons of nuclear waste safely stored for tens of thousands of years.

Using computer models, Laboratory scientists examined a plan being considered that would place large cylinders, each containing 12 tons of waste, in horizontal tunnels 240 to 300 meters within Yucca Mountain. Located 145 kilometers northwest of Las Vegas, the mountain is under study by DOE to determine its suitability as a permanent repository site.

Based on their studies, the Livermore researchers developed a "localized dryout" design approach that provides two key recommendations: (1) position waste containers close together to generate enough heat to lower the relative humidity at the surface of the containers, and (2) surround the waste containers with sand—or layers of gravel and sand—to help prevent water from dripping onto the containers and to increase the temperature difference between containers and the surrounding rock walls. The latter technique would further reduce humidity at the surface of the containers.

The Lab scientists also recommended that tunnels be spaced as much as 45 to 90 meters from one another to mitigate potential water drainage problems.

Laboratory hydrologist Thomas Buscheck said he and his colleagues are looking forward to testing their "barrier concepts" in experiments being planned by DOE in 1996. Tests would place heaters that mimic waste containers into tunnels in Yucca Mountain to see how well Livermore computer codes predict actual conditions.

\* Thomas Buscheck, et al., *Localized Dry-Out: An Approach for Managing the Thermal-Hydrological Effects of Decay Heat at Yucca Mountain*, Lawrence Livermore National Laboratory, Livermore, CA, UCRL-JC-121332 (1995).

### Modeling the Waste Forms

Except for a few gaseous radionuclides, radioactivity would potentially be released from an underground repository when groundwater comes into contact with the waste. Thus, our experimental work on characterizing the waste forms is largely aimed at determining the potential for the release of waste in groundwater. Because we cannot always measure all important variables experimentally, we are using models to predict the thermal, structural, chemical, and nuclear responses of the waste forms over time. These models allow us to extrapolate the results of laboratory experiments to the very long times relevant to a repository.<sup>1</sup>

### Vitrified Waste

Glass is highly durable if kept dry. However, if water contacts the vitrified wastes in a repository, the glass can slowly transform into a composition similar to minerals found in soils.

We have been testing glass durability for almost 10 years under a wide variety of conditions that mimic the anticipated repository environment. At the temperatures we expect, our experiments lasting a few months show that 0.001 to 0.1 grams of glass dissolve per square meter of glass surface area per day. At that rate, the glass would last for several thousand years. Longer-term experiments together with computer models based on glass and

water reactions will allow us to more confidently extrapolate reaction rates to the lifetime of a repository.

We still need to improve our models to account for other interactions among glass, water, and minerals. For example, magnesium, a common geologic element, can slow the dissolution of glass in water by a factor of at least 10. This type of information can be used to enhance the durability of the glass waste forms.

### Spent Nuclear Fuel

To characterize how the spent fuel, the predominant waste, will behave in

the repository, we have focused on determining rates of dissolution and other processes that affect the release of radionuclides. These processes include oxidation of uranium oxide fuel, degradation and failure of the zirconium alloy cladding, and the release of radionuclides from cladding and assembly hardware. From the results of our ongoing experiments, we have developed models to predict these processes over a broad range of variables, including water chemistry, fuel-pellet size, grain boundaries, temperature, radionuclide inventory, and a host of other factors. As with our models for vitrified waste, we are trying

to predict the long-term performance of the total repository system. The dual approach of experiments and models addresses both regulatory and safety issues and is the best way to design a system that must perform for thousands of years. The same type of approach can be used to address complex problems associated with the safe disposal of many other toxic substances.

### Packaging Waste

Three concepts<sup>2</sup> have been selected for the waste packages: both uncanistered and multipurpose canister waste packages for spent nuclear fuel

and a smaller high-level waste package for vitrified waste.

A design for an uncanistered spent fuel waste package is shown in Figure 3a. A basket assembly, which is a large cylinder with partitions, provides structural support for about 20 spent fuel packages and helps to control criticality and heat. The basket is mounted inside a multibarrier metal container. Our concept for this container is to use two different layers of metal, each of which performs a different function in the oxidizing geological environment. By selecting diverse barriers that provide different types of protection, we can minimize the possibility of failure by any single mechanism.

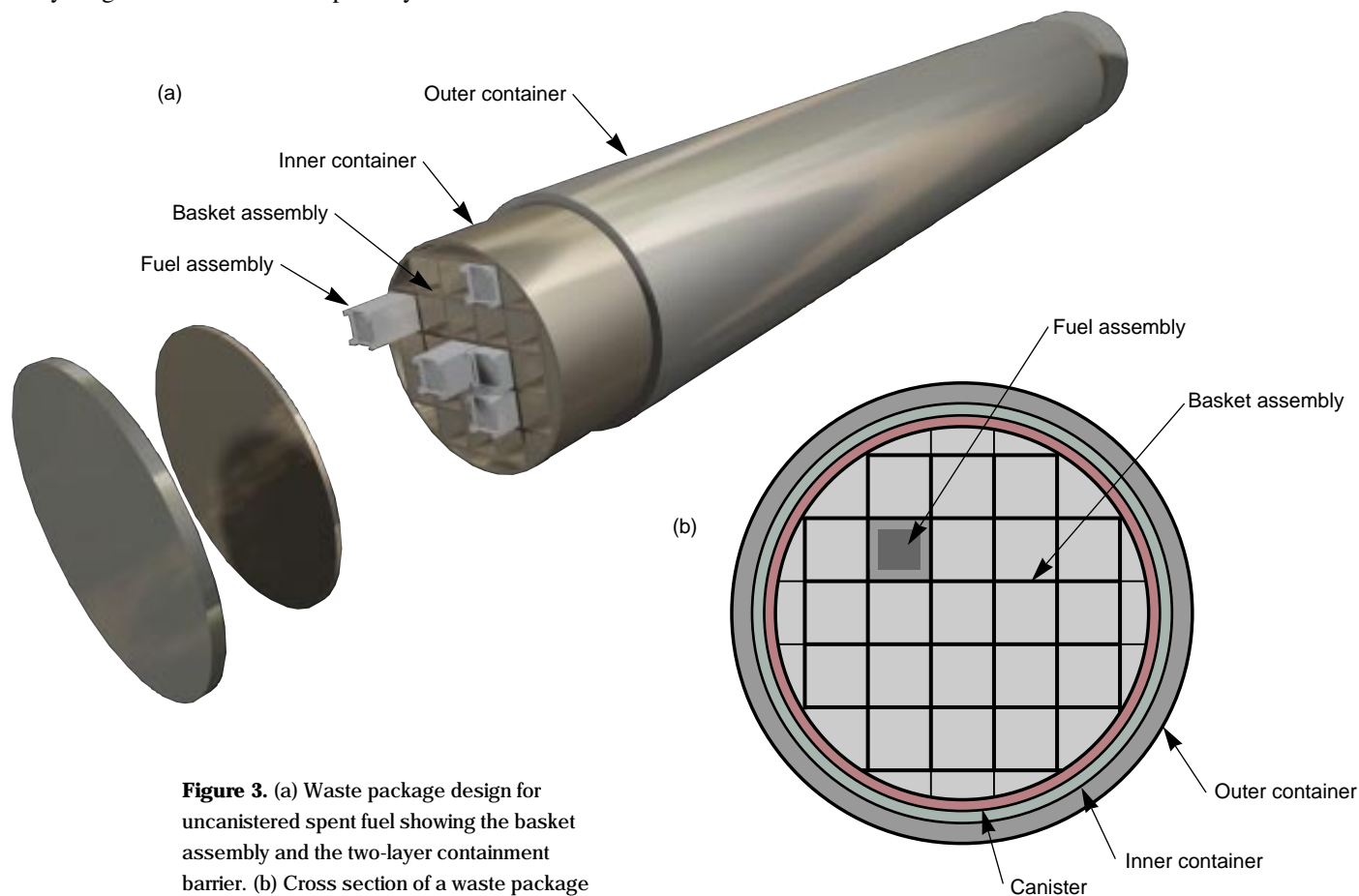

**Figure 3.** (a) Waste package design for uncanistered spent fuel showing the basket assembly and the two-layer containment barrier. (b) Cross section of a waste package containing a multipurpose canister used for transportation, storage, and disposal.

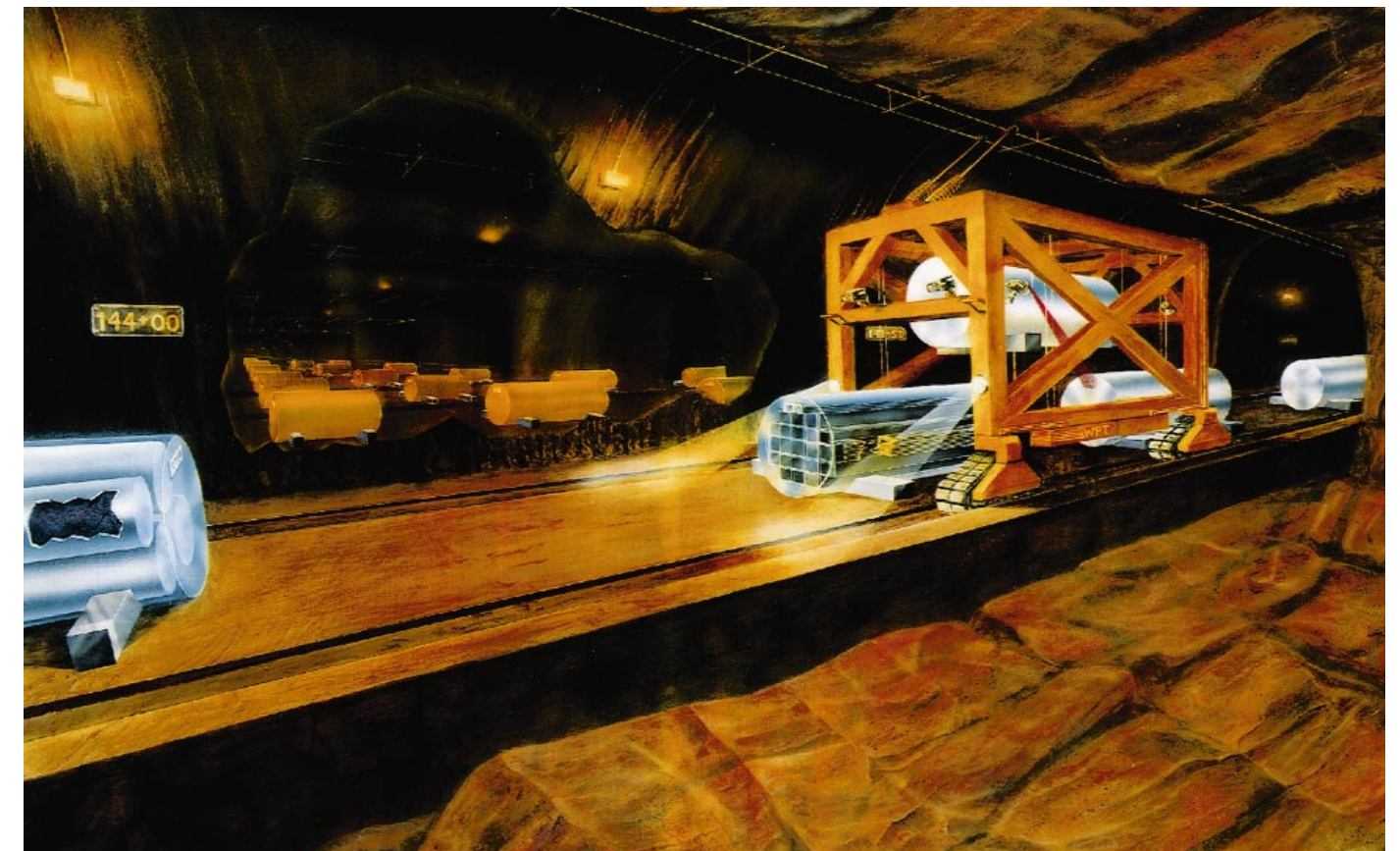

**Figure 4.** Waste packages will be placed on rails in horizontal tunnels, called drifts, about 300 meters underground. The tunnels would remain open for 100 years to permit monitoring and to allow for retrieval if a problem is discovered or if some use is found for the spent fuel. After that period, the tunnels would be filled and sealed.

A 2-cm-thick inner layer of highly corrosion-resistant material will contain the radionuclides. A 10-cm-thick outer layer of less expensive corrosion-allowance material will protect the inner layer and attenuate gamma rays. The outer layer is a sacrificial barrier, similar to the lining of tin that protects the steel of a tin can. Because this layer is thick and corrodes at a very low rate when the waste is at high temperature, it protects the corrosion-resistant layer for a prolonged period.

A design for the multipurpose canister waste package is shown in [Figure 3b](#). This package is similar to the one just described except that it adds a

large cylindrical canister between the basket assembly and the outer multibarrier container. These multipurpose canisters, thousands of which will be filled and sealed at reactor sites, will be designed to be safe for both transportation and disposal.

At the repository, an unopened multipurpose canister will be inserted into our disposal containers to make up the complete waste packages ([Figure 4](#)). Filler material may be placed in the space around fuel rods to help exclude water, transfer heat, control criticality, and provide chemical buffering. Packing and backfill may also be used outside, under, or near the waste packages. This material can help to restrict water access or to sorb radionuclides. The engineered barrier system includes all of the above components.

For the smaller amounts of high-level waste generated by defense programs, three or four canisters containing borosilicate glass waste will be inserted into a multibarrier metal container.

The materials we are evaluating for structural containers are intended to provide substantially complete containment of nuclear waste between 300 and 1,000 years after the repository is closed. Of all the properties relevant to the waste package materials, the most important is corrosion behavior.

### Testing, Selecting Materials

At Lawrence Livermore, we are testing materials for the spent-fuel basket assemblies, the multilayer containers, and filler. Focusing mostly on the containers, we evaluated 41 materials, including nearly all major families of engineered alloys, and have narrowed the list of candidates using criteria such as corrosion resistance,

mechanical performance, cost, and ease of fabrication.<sup>3</sup>

Many considerations govern the tests we perform, the models we are developing, and the materials finally selected. One of the most important factors is that a repository environment starts with very high temperatures and dry conditions, and it becomes cooler (about 100°C after 1,000 years) and more humid over time. Depending on the metal and its temperature, corrosion can become significant at a relative humidity above about 60%. Some of our tests, such as thermogravimetric studies ([Figure 5](#)), are designed to identify this critical transition point in candidate metals.

For a container made of two different metal layers, we want to select materials that will interact beneficially and age differently as the repository environment changes from drier to moister. Other variables that we design into our tests are based on the following facts:

- Several different types of corrosion are possible, including localized pitting, crevice corrosion, and stress corrosion cracking.
- The contents of the approximately 12,000 waste canisters will differ in terms of their radiation, chemistry, and temperature. Gamma radiation affects corrosion mechanisms as do other variables arising from the waste form.
- The effect of welds and mechanical stresses on metal must be assessed along with the shapes and compositions of small metal parts ([Figure 6](#)) and the configuration of the containment barriers.
- Other repository structures, such as concrete and grouts, interact with the metal containers.

• Microbes can drastically change the chemical environment. In acidic conditions, microbes can cause high corrosion rates in metal at temperatures of 30 to 120°C. This is a relatively new area of study.

In tests on a laboratory scale, we intentionally accelerate the aging and deterioration of candidate metals so we can extrapolate results to thousands of years. For the first time, our new Integrated Corrosion Facility (see the [box on p. 16](#)) allows us to run tests for five years or longer. We are also developing modeling tools to help predict localized corrosion and other processes.

Primary candidate materials being studied are high-performance nickel and titanium alloys for the inner containment

barrier and carbon steel for the outer, sacrificial containment barrier.

Nuances in alloy composition are important. Nickel-rich stainless alloys are known as “super stainless steels” in which increased nickel content confers added corrosion resistance. Alloy 825 is a nickel–iron–chromium alloy (40 to 60% nickel) developed for equipment to handle sulfuric acid. It is a strong candidate for the inner barrier with excellent corrosion and oxidation resistance and desirable mechanical properties. However, it may have less resistance to crevice attack than some alternative alloys with more molybdenum content. Titanium-based alloys (1% or less of alloying elements) have excellent corrosion resistance to

**Figure 5.** A thermogravimetric analyzer tests for oxidation of metals exposed to environments of 50 to 90% relative humidity. Livermore researcher John Estill adjusts the equipment for tests that can run 1 to 30 days at temperatures of 50 to 250°C.

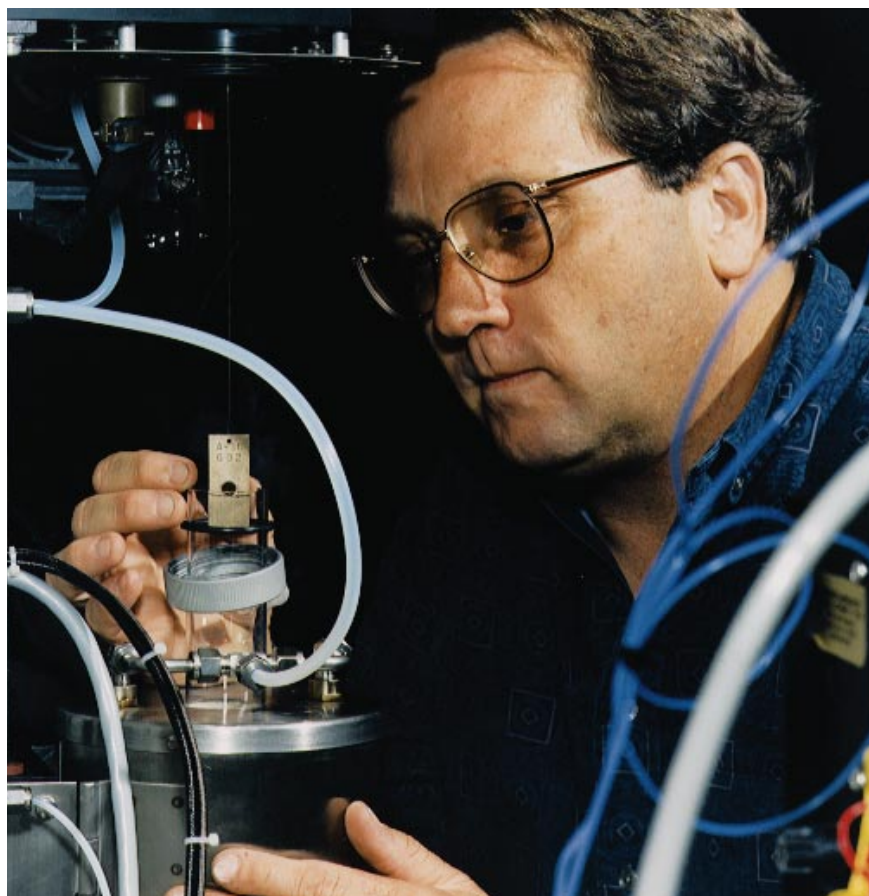

**Figure 6.** Some of the thousands of metal alloy samples we are subjecting to stress, heat, water, and chemicals to determine their long-term performance: penny shapes of copper for electrochemical disks, stainless steel U bends for stress–corrosion tests, a ring of plasma-sprayed carbon steel, and large U bends of pure copper and copper–nickel for aggressive tests of welded samples.



**Table 2.** Near-field environment studies and accomplishments by LLNL.

**LLNL focus areas**

- Chemistry of fluids that can contact waste and containers.
- Waste form and other engineered barrier system components.
- Mechanical loading imposed on containers and other components.
- Thermal environment.
- Formation of colloids.
- Potential biological activity and interactions.
- Electrical potential interactions.
- Transport and retardation mechanisms.

**Computer models**

- LLNL-developed EQ3/6 for chemistry of rocks and water.
- V-TOUGH and NUFT codes for hydrology and thermohydrology.
- Geomechanical codes for fracturing in rock.

**Laboratory tests**

- Geochemical tests for rock and water interactions.
- Hydrologic and geomechanical properties of rock at elevated temperatures.
- Drying and rewetting of fractures.
- Breakdown of organics, such as diesel fuels.
- Long-term effects of microbes on concrete.

**Field tests**

- Climax Mine underground tests (early 1980s).
- G-Tunnel test at Nevada Test Site (October 1990).
- Tests on a large block of tuff.
- Tests on analogous formations around the world.
- Exploratory Studies Facility (boring is ahead of schedule for this 5-mile loop tunnel under Yucca Mountain).

**Figure 7.** We are preparing this 3- x 3- x 4.5-m rock for our near-field studies. The outer straps (shown partially in place) will help keep the rock from fracturing during tests and provide insulation. We are placing heaters on the exterior of the rock and in five boreholes within the rock. Monitoring instruments capable of gathering 1,000 channels of data are also being placed in boreholes in the rock.

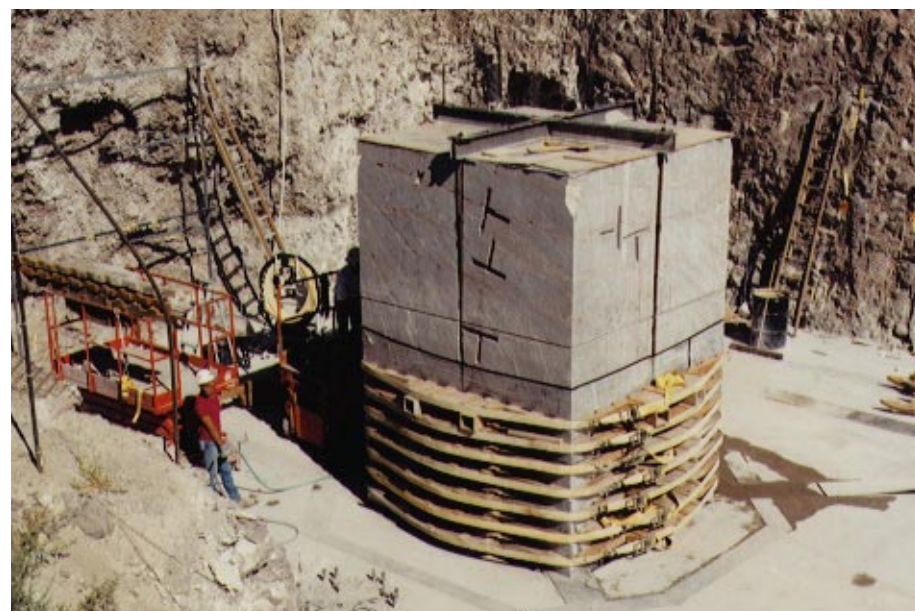

oxidizing environments and microbial attack, low density, and high strength, but they can lose resistance in reducing acids and in crevices. Carbon steel for the outer barrier is an excellent choice in hot, dry conditions, but we must take into account that its corrosion rate becomes higher in wet conditions.

Trade-offs like these together with issues of cost and other possible failure mechanisms will continue to direct our research and the final choice of materials. By studying both expected and worst-case conditions that are possible in a repository, we can identify the best materials and designs to withstand those conditions. Testing and modeling materials are ongoing activities that yield greater confidence over time. As an added precaution, materials tests will continue even after a repository is built because the waste packages will be retrievable for many years.

**Near-Field Environment**

The immediate, or near-field, environment surrounding the waste will change over thousands of years as heat and radioactivity interact with water, rock, and introduced materials. The altered environment will, in turn, affect the waste packages.

Our near-field studies include the disciplines geochemistry, geohydrology, hydrothermal interactions, geomechanics, manmade materials, field tests, and modeling. We have published a two-volume *Preliminary Near-Field Environmental Report* that summarizes our extensive studies.<sup>4</sup> Table 2 lists many of our accomplishments.

A good example of our current work is the tests we plan to conduct on a heavily instrumented, room-size block of rock (Figure 7) adjacent to the proposed Yucca Mountain site. We are placing heaters in five boreholes within the rock and surrounding the sides with

additional heaters. Instruments in this rock will gather 1,000 channels of data on moisture, temperature, geochemistry, water chemistry, corrosion of metal samples, gas pressure and vapor, acoustics, deformation, and rock stresses. After collecting data for about a year and a half, we will take the rock apart to gather more information.

The Exploratory Studies Facility, now being constructed, will provide us with on-site laboratories deep within Yucca Mountain in 1996. We plan an extensive series of tests that will give us much more specific data on the hydrology and geochemistry of the actual environment. Such data will allow us to develop more accurate computer models of processes affecting the repository.

**Putting It All Together**

Ultimately, we must have very high confidence in the long-term safety of the potential repository. Figure 8 is a broad view of how we are analyzing each aspect of the engineered barrier system and near-field environment to come up with the required measure of total system performance needed for licensing. Performance analysis of the waste package design and repository drives our entire program and will determine its success.

To more readily visualize the many elements making up our analysis, Figure 8 represents the factors leading to total system performance as a pyramid. At the base of the pyramid is our detailed work on the waste form and containers and on the waste package environment, which is being analyzed by means of our near-field studies.

In the middle of the pyramid are the models we are developing to describe the long-term behavior of the engineered barrier system and the

environment in which it will function. Some of our models are computer-based, while others are mathematical or analytical. This work uses data from other models, such as those in geochemistry or hydrology, to determine how processes will interact over thousands of years.

Toward the top of the pyramid are the subsystem models describing performance of the engineered barrier system. For example, the PANDORA model is a detailed time evolution of a single waste package. We have also developed the Yucca Mountain Integrated Model, which combines information on the engineered barrier system with that on the near-field environment. This model tells us which trends are most significant and what data are essential for predicting

repository performance. We can use this information to plan additional tests and to further analyze designs. Eventually, our subsystem models can be used to develop the ultimate model of the entire repository with all elements included, that is, to assess total performance.

The models in Figure 8 are representations of experiments. To test our representations and verify that a code correctly represents real processes, we will continue to conduct laboratory and field tests. For example, we can couple the release of radionuclides and their potential movement through heated rock to compare test data with a model's predictions. When

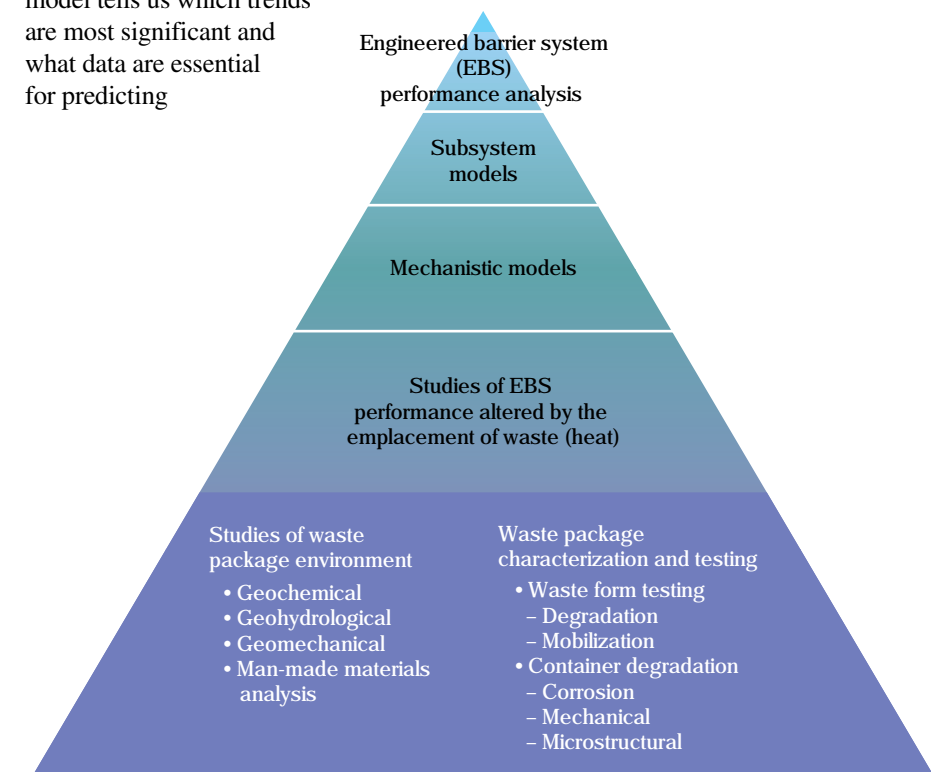

**Figure 8.** Summary of LLNL's role in repository research. Starting with the waste package (bottom right) and our near-field studies (bottom left), we are developing models for evaluating the total performance (top) of an engineered barrier system.

the Exploratory Studies Facility is completed at Yucca Mountain, we will proceed with more extensive integrated tests to validate our models and methods.

**Key Words:** engineered barrier system (EBS); high-level radioactive waste; spent fuel; Yucca Mountain Project.

#### References

1. R. B. Stout and H. R. Leider, *Preliminary Waste Form Characteristics Report*, Lawrence Livermore National Laboratory, Livermore, CA, UCRL-ID-108314 (Rev. 1) (1994).
2. *Initial Summary Report for Repository/Waste Package Advanced Conceptual Design*, TRW Environmental Safety Systems, Document No. 00000000-01717-5705-00015, Rev. 1 (August 29, 1994).
3. R. A. Van Konynenburg *et al.*, *Engineered Materials Characterization Report for the Yucca Mountain Site Characterization Project*, Lawrence Livermore National Laboratory, Livermore, CA, UCRL-ID-119564 (Vols. 1, 2, and 3) (1995).
4. D. G. Wilder, *Preliminary Near-Field Environmental Report, Volume I: Technical Bases for EBS Design; Volume II: Scientific Overview of Near-Field Environment and Phenomena*, Lawrence Livermore National Laboratory, Livermore, CA, UCRL-LR-107476 (Vols. 1 and 2) (1993).

**For further information contact**  
**Bill Clarke (510) 423-4571**  
([clarke1@llnl.gov](mailto:clarke1@llnl.gov)).

### Integrated Corrosion Facility

To project effects on candidate metals over a hundred centuries, we need to do laboratory corrosion testing for as long as possible, several years at least. Our new corrosion-testing laboratory at Livermore (Building 435) allows us to investigate modes of degradation in candidate materials for the required times.

This facility contains several dozen large tanks approximately 1 meter square and 2 meters high in which we can simulate conditions that are possible at a repository. Test solutions are varied and controlled for temperature, pH (acidity), solution chemistry, and many other variables. Metal samples are immersed in the aqueous solutions or subjected to the vapor phase to study generalized, localized, and stress-assisted corrosion.

Some samples will be exposed for five years or more, still just a fraction of the time the material must last in the repository. To measure changes in corrosion rates, we will remove samples of candidate materials at six-month intervals for kinetic and mechanistic analysis. Some of our exposure conditions, such as electrochemical polarization, intentionally accelerate the corrosion process. For different exposure conditions, we use computer models to project corrosion effects to much longer times. Thus, the effects we assess can correspond to the vastly longer exposure times in an underground repository.

#### About the Scientist



**WILLIS L. CLARKE** received his B.S. in metallurgical engineering from the University of Nevada, Reno, in 1960. He joined the Laboratory's Chemistry and Materials Science Department in 1989 after holding several research and managerial posts, including lengthy service as principal engineer at the Vallecitos Nuclear Center at Pleasanton, California. Since 1991, he has been project leader at Lawrence Livermore for the Yucca Mountain Site Characterization Project, managing a staff of from 40 to 80 researchers

focusing on the design of an engineered barrier system for a permanent nuclear waste repository. He has published more than 80 articles on materials performance, including the effects of radiation, oxidation, and corrosion on metals and alloys.

# The Diamond Anvil Cell: Probing the Behavior of Metals under Ultrahigh Pressures

*In the absence of nuclear testing, the Laboratory's diamond anvil cell is helping to assure the safety and reliability of our nation's nuclear stockpile. Because it uses very small samples, the diamond anvil cell is a cost effective way to collect accurate, reliable data about the physical and chemical behavior of weapons materials under the ultrahigh pressures encountered in an imploding nuclear weapon without the possibility of radioactive contamination.*

**H**OW materials behave under extreme conditions is of more than scientific interest to Livermore researchers. Issues related to national security are a major motivation. During the implosion of a nuclear weapon, the materials are driven inward, reaching enormously high pressures and temperatures, until they achieve the supercritical state that is necessary for nuclear fission. During the process, the ultrahigh compressions subject the weapon's materials to

continual change in physical properties such as volume, structural state, and density. These changes strongly affect the course of the implosion and therefore the final explosion. Weapon designers need to know exactly what those material properties are and how they change during the implosion process if they are to calculate and reliably predict the performance of a weapon. However, the great violence and brevity of a nuclear event combine to inhibit the collection of precise data.

Until roughly two decades ago, the only alternative to nuclear tests for measuring the properties of materials at ultrahigh pressures and temperatures was shock experiments—shock waves were driven through the material of interest while changes in the material properties during passage of the shock front were measured. However, because shock techniques are dynamic, precise material properties are difficult to measure directly. Instead, the diagnostics were focused on measurements that could be captured in such brief durations; then, using large-scale numerical simulations that incorporated data from the experiments, researchers inferred the properties of interest.

### The Diamond Anvil Cell

The diamond anvil cell (DAC) has changed these circumstances because of the pressure and temperature regimes to which a sample can be subjected. It joined shock experiments and tests driven by high explosives as means of providing the experimental data that are important starting points for science-based stockpile stewardship. This apparatus enables Lawrence Livermore researchers to measure many of the properties of interest directly under static pressure conditions (instead of indirectly as in dynamic shock-wave experiments). The use of static pressure means that ultrahigh pressures can be maintained for significantly longer times than in shock experiments, allowing more accurate measurements to be taken directly. Pressures within the diamond anvil cell can approach 350 gigapascals (1 GPa =  $\sim 10,000$  atmospheres\*) and

temperatures can approach 6,273 kelvin (10,832°F, 6,000°C)—that is, pressure and temperature equal to those at the center of the Earth.

The DAC is also more cost effective than shock-wave experiments. Instead of providing only one volume–density number at a given pressure per experiment, it provides a range of data across the pressure spectrum of the experiment and thus more information for fewer experiments. Another advantage of the DAC is the small sample size needed. Each experiment requires about a microgram of an element, significantly less than in a weapon. The small samples present minimal possibility of radioactive contamination, and containment of the small amount of radiation is assured.

The DAC's capabilities are particularly important for weapons physicists now that the United States is no longer conducting nuclear tests. The safety and reliability of nuclear weapons must now be maintained with indirect experimental techniques and large-scale computations. In particular, the DAC enables direct measurements of changes in volume and density, as a function of changes in the material's crystal structure and of melting under high pressure, that strongly influence the hydrodynamic stability of imploding systems. Fifty years ago, instability was an intractable problem for the designers of the first nuclear weapons. Despite major advances in science and technology, our understanding of instability remains limited because the actual physical state of the material experiencing these changes in volume and density often could not be measured. The DAC now changes this situation. It can provide

some of the data required to accurately predict the yield and performance of nuclear weapons—and thus their safety and reliability—without nuclear weapons tests.

LLNL's physicists also use the DAC data to interpret the data collected from earlier shock-wave experiments. Shock waves passing through a material raise its pressure and temperature simultaneously, making it difficult for researchers to identify with certainty the separate effects of pressure and temperature alone from the data. By statically compressing the same type of material at room temperature in the DAC, we can isolate the effects of pressure on the changing pressure–density relationship (i.e., equation of state) of the material. Physicists then use these data to calculate the temperature component from the shock data and thus derive separate pressure and temperature values for those data. They thus deduce further information about the high-temperature equation of state and phase stabilities useful to weapons physicists in confirming or modifying the complex theoretical calculations upon which weapons computer codes are based.

Figure 1 shows a comparison of DAC data with data from shock experiments recalculated using a theoretical equation-of-state model for uranium. The slight discrepancy between the DAC and theoretical equations of state suggests that the parameters chosen for the theoretical calculations may need further minor modifications that could lead to more accurate predictions of weapon safety and yield. The DAC is thus an important tool that provides weapons

physicists with the experimental data that allow them to improve the calculations upon which weapons codes are based without doing actual nuclear tests.

### The Compressing Mechanism

The diamond anvil cell is a small mechanical press that forces the small, flat faces (the culets) of two flawless, brilliant-cut diamonds together on a microgram-size sample to create very high pressures in the sample (see Figure 2).<sup>1</sup> It uses diamonds because, as the hardest known solid, they do not break or deform under the intense pressures of the DAC and are transparent to light and x rays. The mechanism for applying the pressure is a stout lever with a mechanical advantage of 10:1. It is actuated by a heavy screw and Belleville springs at the long end. (Belleville springs are cupped washers stacked back to back around the screw to apply a balanced pressure.) The diamonds, which range from one-eighth to one-third carat each, are in an opposed anvil configuration and mounted over zirconium pads on a pair of tungsten-carbide rockers. These rockers (hemicylinders with their axes at right angles) can be tilted to align the culet faces perfectly parallel. Apertures in the rockers permit x rays and other kinds of radiation to enter and exit through the diamond anvils, thus allowing for diagnostics and heating during experiments.

We customize the surface shapes of the diamonds for the pressures at which we perform experiments. For experiments at pressures below 500,000 atmospheres (50 GPa), each diamond is ground to have a flat face that ranges from 100  $\mu\text{m}$  (micrometers) to 500  $\mu\text{m}$  in diameter; for experiments at still higher

pressures, we use beveled diamonds having a 7- to 8.5-degree bevel on a 300- $\mu\text{m}$  culet with a 30- to 75- $\mu\text{m}$  flat face. (As points of reference, a standard sheet of paper is about 50  $\mu\text{m}$  thick and a human hair is about 100  $\mu\text{m}$  in diameter.)

Once the diamonds are perfectly aligned, we remove the tight-fitting piston that holds one of the two diamonds in place. Between the culets of the anvils, we place a 250- $\mu\text{m}$  thick gasket (a strip or circular metal disc of tool steel or rhenium) and apply a small force to indent or prepress its surface. Then we drill a hole that is 30 to 150  $\mu\text{m}$  in diameter in the center of the indented area. Into that hole we place the sample with a pressure medium—liquid, gas, or solid—which helps to distribute the compressive force of the diamond faces.

To calibrate pressure during the experiment, we add a pressure marker, such as a small ruby chip or platinum powder. Under illumination of a helium-cadmium laser, the ruby chip emits fluorescent light at characteristic frequencies (spectral lines), the

wavelengths of which are calibrated as a function of pressure against a known marker material. The volume of the platinum under pressure can be calculated from the x-ray lattice parameters and compared with the known pressure–volume relationship from shock-wave data in order to ascertain the sample pressure. (The pressure marker acts as a pressure sensor and also indicates when the applied stress becomes nonuniform.) When the pressure is no longer hydrostatic, because, say, a fluid pressure medium has become a solid or has become very viscous, the resulting nonuniform stress broadens the ruby fluorescent peaks.

### The Diagnostics

A significant advantage of the DAC is that diamonds are transparent to x rays and visible light. We exploit this feature when we watch the changes in the material as the pressure and temperature are changed. To determine the sample material's crystal structure during an experiment, we collimate the x-ray beam, selecting rays nearly

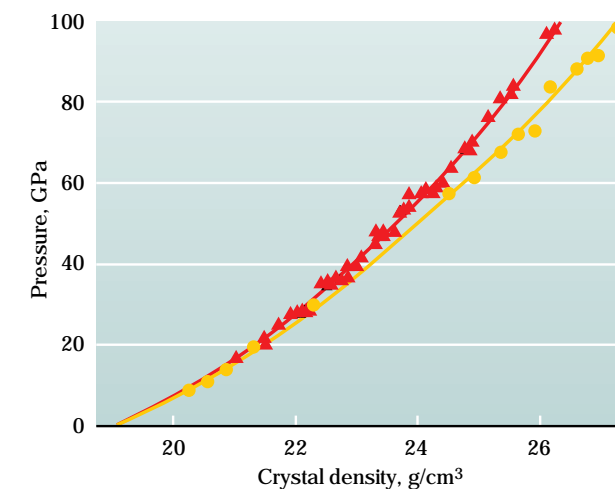

**Figure 1.** Comparison of diamond anvil cell data (●) with values calculated from a theoretical equation-of-state model for uranium using data from shock experiments (▲). The plot shows that the data derived from theory and shock experiments warrant correction by the data from the diamond anvil cell.

\* 1 atmosphere = the ambient air pressure at sea level.

parallel to one another with a slit system.<sup>2</sup> We pass the well-collimated beam of monochromatic (single-energy) x rays from a rotating anode generator through the sample and both diamonds and record the resulting diffraction pattern on x-ray film (see Figure 3). Efficient computer programs interpret the resulting patterns, which consist of a complex series of concentric arcs or reflections in a spectrum. These x-ray diffraction patterns thus become the

means of “seeing” the changes in the crystal structure of the sample and collecting data about its changing equation of state under the intense pressure of the DAC.

Commonly, phase transformations are thought of as those from a solid to a liquid to a gas. However, there are transformations from one solid to another, and these are the structural transformations generally studied using the DAC. In solid-to-solid structural changes, the atoms of an element rearrange themselves in response to changing pressure, changing temperature, or both to new configurations. The shape of the atomic structural “cages” changes by the rearrangement of the atoms. Structural changes can be accompanied by a sudden volume change. However,

the volume change can be small enough not to be recognized or to be able to be accounted for by a normal margin of experimental error. It can also be smooth and gradual and not exhibit the spikes associated with large, sudden changes. Whether subtle or sharply defined, these are the structural transformations of interest in DAC experiments.

The diagnostic x rays used to record these data in our DAC experiments at ultrahigh pressures are not like those from medical or conventional laboratory x-ray units, which are too weak to yield data in a reasonable time and cannot be collimated sufficiently to collect accurate data. Rather, we use the very bright, highly coherent x rays from a synchrotron source such as the one at the National Synchrotron Light Source

at Brookhaven National Laboratory in New York State and collimate them to 5 to 10 μm in diameter. A combination of high beam intensity and excellent collimation is essential to reduce the time required for data collection (10 to 30 minutes at each pressure, rather than tens of days) as well as to reduce the effects that the pressure gradient across the sample has on the data.

When pressures exceed 40 gigapascals (GPa), we use the apparatus shown schematically in Figure 4 to record the diffraction pattern. First, we use a pair of adjustable slits to collimate the beam from the synchrotron x-ray source to a diameter of less than 10 μm. Then we clamp the DAC, with sample and ruby-chip pressure marker in place, to a four-circle goniometer\* in order to align the DAC with respect to

**Figure 2.** (a) Schematic of the diamond anvil cell. (b) The cell disassembled, showing the major optical and mechanical components. (c) Close-up of the apparatus for holding and compressing the sample.

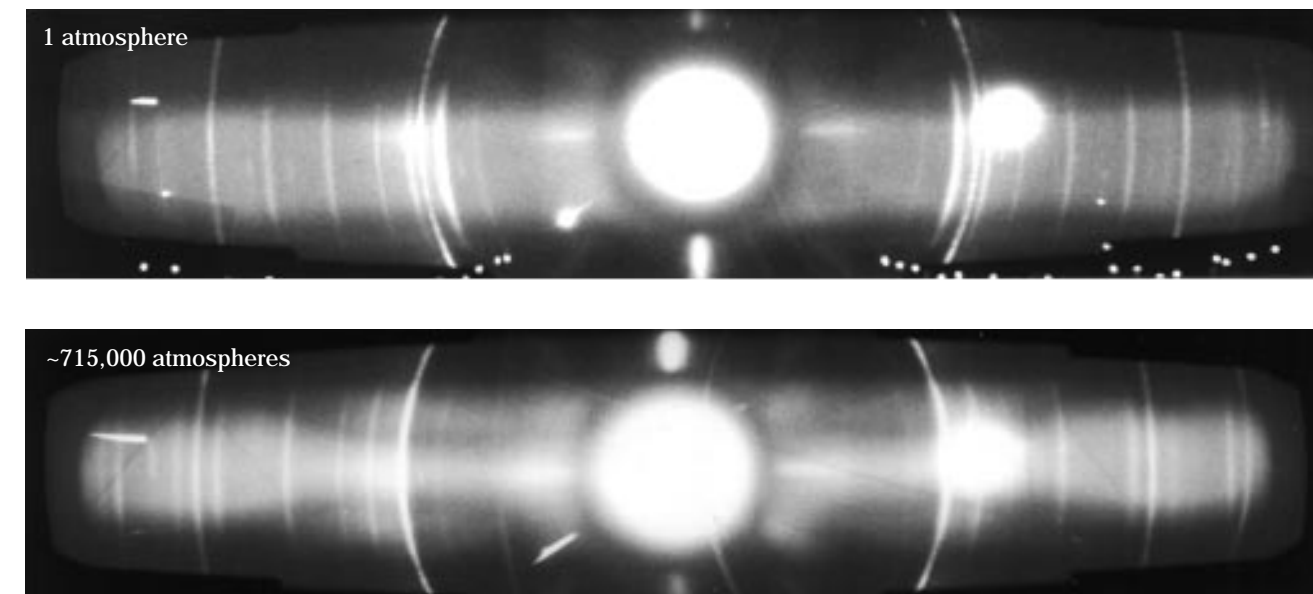
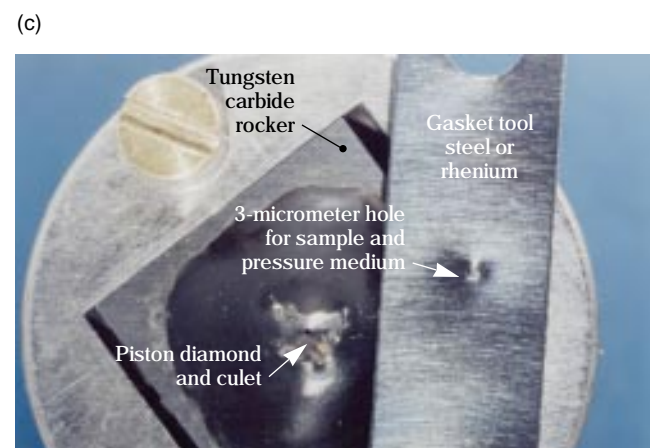
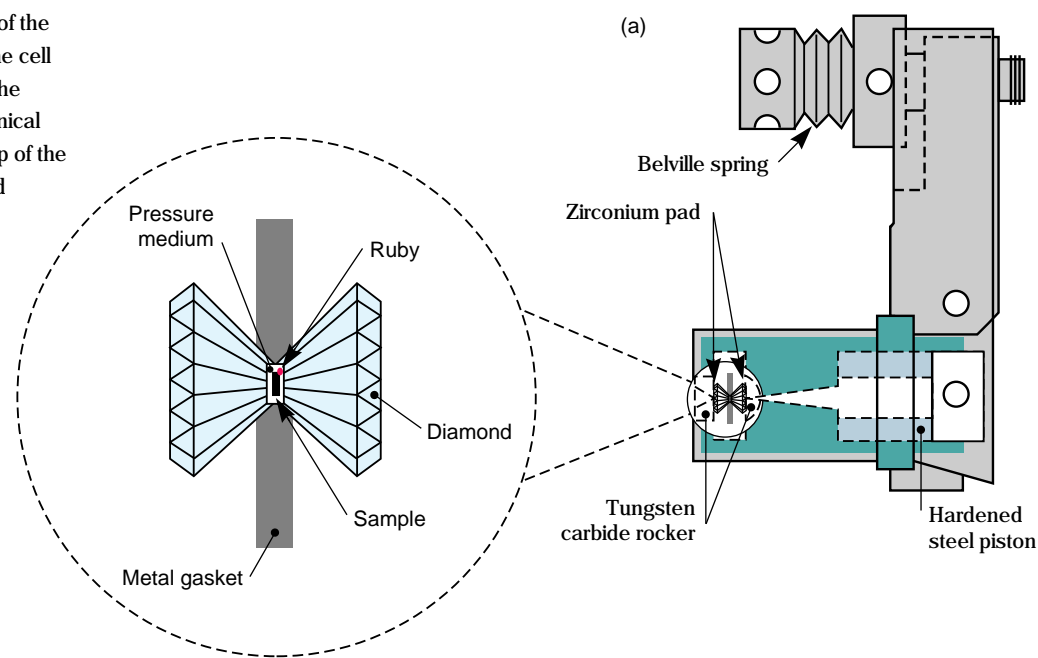

**Figure 3.** The experimentally interpreted structural sequence for uranium at increasing pressures recorded as an x-ray diffraction pattern by a collimated x-radiation experiment. It is x-ray diffraction patterns like these, but at much higher pressures, that provide the diamond anvil cell data of use to weapons physicists.

\* A goniometer is an instrument with a number of degrees of freedom to move a crystal in space and uses x-ray diffraction to measure the angular positions of the axes of a crystal.

the x ray. Aided by the ion chamber, we align the DAC so the 10- $\mu$ m-diameter x-ray beam probes the center of the sample (the area of greatest pressure and the least pressure gradient). The penta prism is essentially a microscope that directs light so that we can see the sample prior to experiments. The x-ray beam from the synchrotron source passes through the diamonds, diffracts from the sample, and passes through the pinhole collector in the upper part of the apparatus. It then enters the germanium-lithium detector, which records the energy diffraction pattern from the sample, data essential to identify the changing crystal structure. The optical multichannel analyzer in the lower part of the apparatus determines the pressure at which the crystal changes take place by measuring the laser-induced fluorescent light from the ruby-chip pressure marker. Thus, the changing volume and density of the sample are measured as a function of pressure.

### Heavy Metals Experiments

As part of our continuing investigation into the high-pressure properties of metals, we have used the diamond anvil cell to determine the pressure-volume relationship and any possible changes in the crystal structure for some actinide and lanthanide metals to approximately 325-GPa pressure at room temperature. **Figure 5** shows the lanthanide and actinide series from the periodic table of the elements; shading highlights those elements we have studied in some depth. The Laboratory is the world leader in the study of lanthanides and actinides under extreme static pressure and temperature conditions.

One purpose of these investigations is to obtain consistent, thorough data of general scientific interest about the properties of these metals under pressure. Another is to study the

behavior of the actinide weapons metals uranium and plutonium under pressures approaching those in imploding nuclear weapons. These purposes, however, are not separate. In theory and reality, there are connections between the high-pressure behavior of elements in both series that are of particular relevance to the high-pressure behavior of the actinide weapons metals uranium and plutonium.<sup>3</sup> Representative DAC findings about lanthanides and actinides illustrate how DAC research works in general and how it contributes to weapons safety in the absence of nuclear testing.

Our findings concerning the lanthanides and actinides to date fall into three categories: those concerning the lanthanides, those concerning the heavy actinides (americium through the end of the series), and those concerning the lighter actinides (thorium, uranium, neptunium, and plutonium).<sup>\*</sup> In all

three categories, we are in search of data about the stability—or lack of it—in each crystal structure and the equation of state under ultrahigh pressures. We are looking for structural changes as a function of pressure and temperature, changes in volume (density) due to the structural changes, the ultimate structural form that is stable for these elements, and the similarities between lanthanides and actinides. These are the data that physicists require in combination with shock-wave-derived data to confirm or modify the theory concerning the high pressure behavior of these metals upon which weapons code calculations for uranium and plutonium are based. These DAC data can improve the precision of the

computer codes for the behavior of weapons materials and thereby improve the predictability of their structural behavior in the weapons regime.

### The Lanthanides

The lanthanides, or rare-earth series of elements (elements 57 through 71 of the periodic table—lanthanum through lutetium), are nearly indistinguishable in their chemical behavior. Although they all have the same outer electronic shell configuration, each element has one more electron than its next lighter neighbor. This additional electron is located deep within the atom's electron structure. This configuration causes a smooth progression of physical properties across the series but has little

effect on chemical properties. The normal (unpressurized) crystal structures of these elements (**Figure 6a**) show a regular progression across the series.

We studied the lanthanides in the DAC primarily to confirm experimentally the broadly related pattern of the elements' crystal structure across the series predicted by theoreticians.

Our detailed studies of some rare-earth elements have experimentally confirmed the existence of the structural sequence predicted by theoreticians. As pressure increased, the lanthanides transformed to face-centered cubic and a six-layered structure (**Figure 6b**). Under increasing pressure, the lanthanides follow the

**Figure 4.** The configuration of our static high-pressure experiments using synchrotron radiation, the means of recording accurate diffraction patterns of materials in a reasonable time when pressures exceed 40 gigapascals.

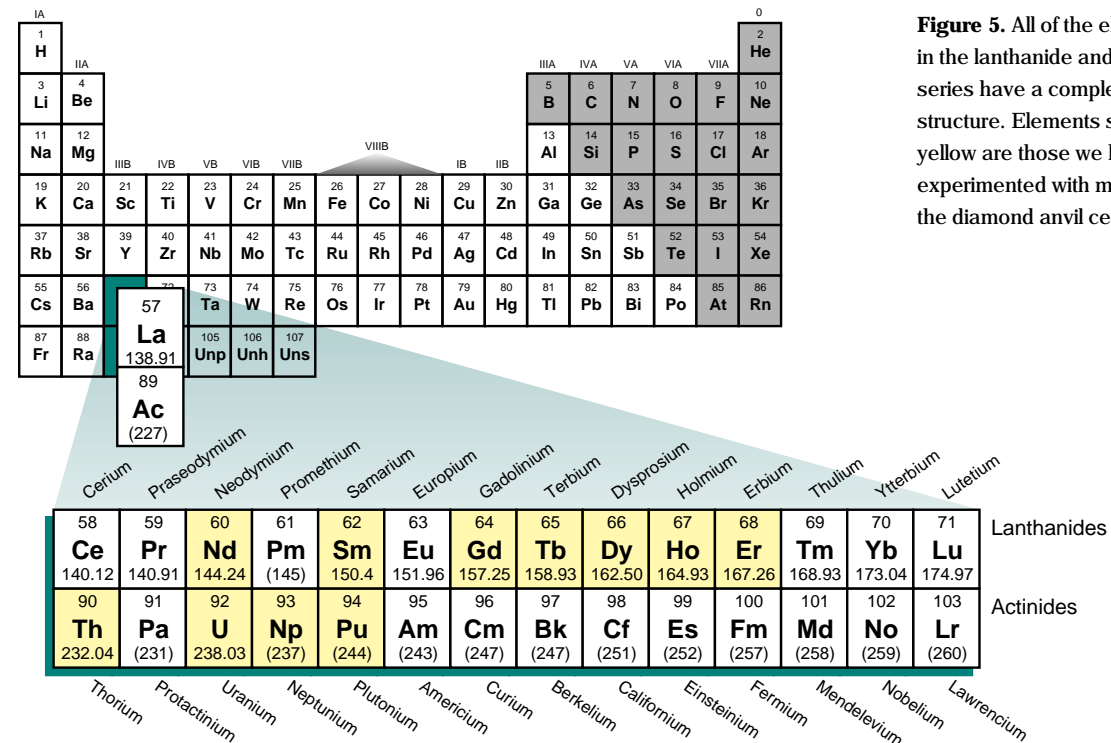
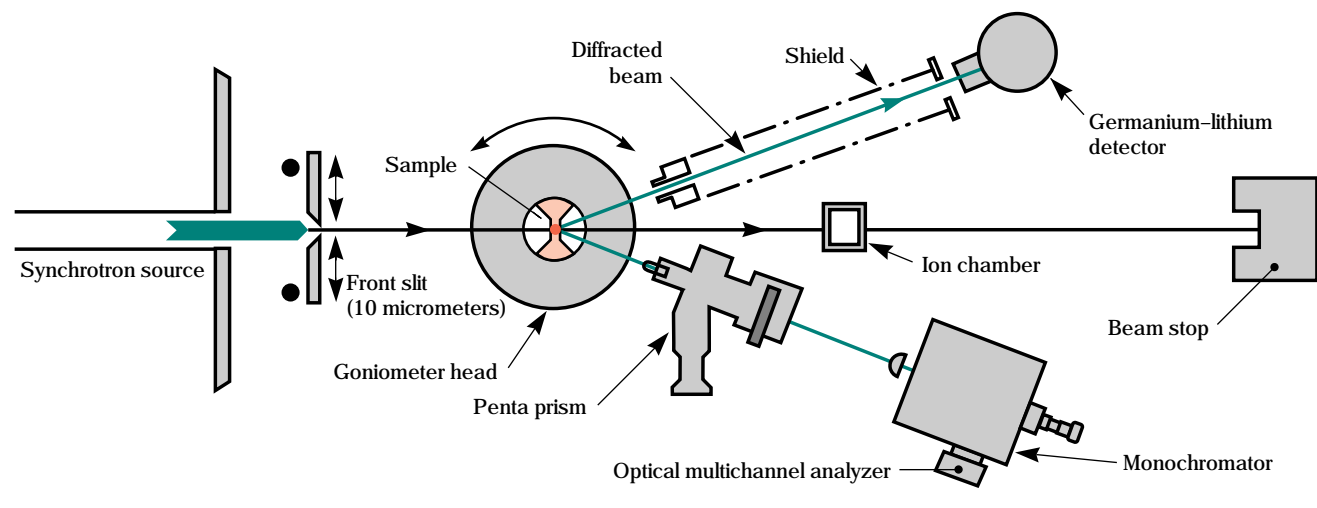

**Figure 5.** All of the elements in the lanthanide and actinide series have a complex atomic structure. Elements shaded yellow are those we have experimented with most using the diamond anvil cell.

\* We have avoided DAC experiments with protactinium because it is too radioactive even in the small quantities needed for our work.

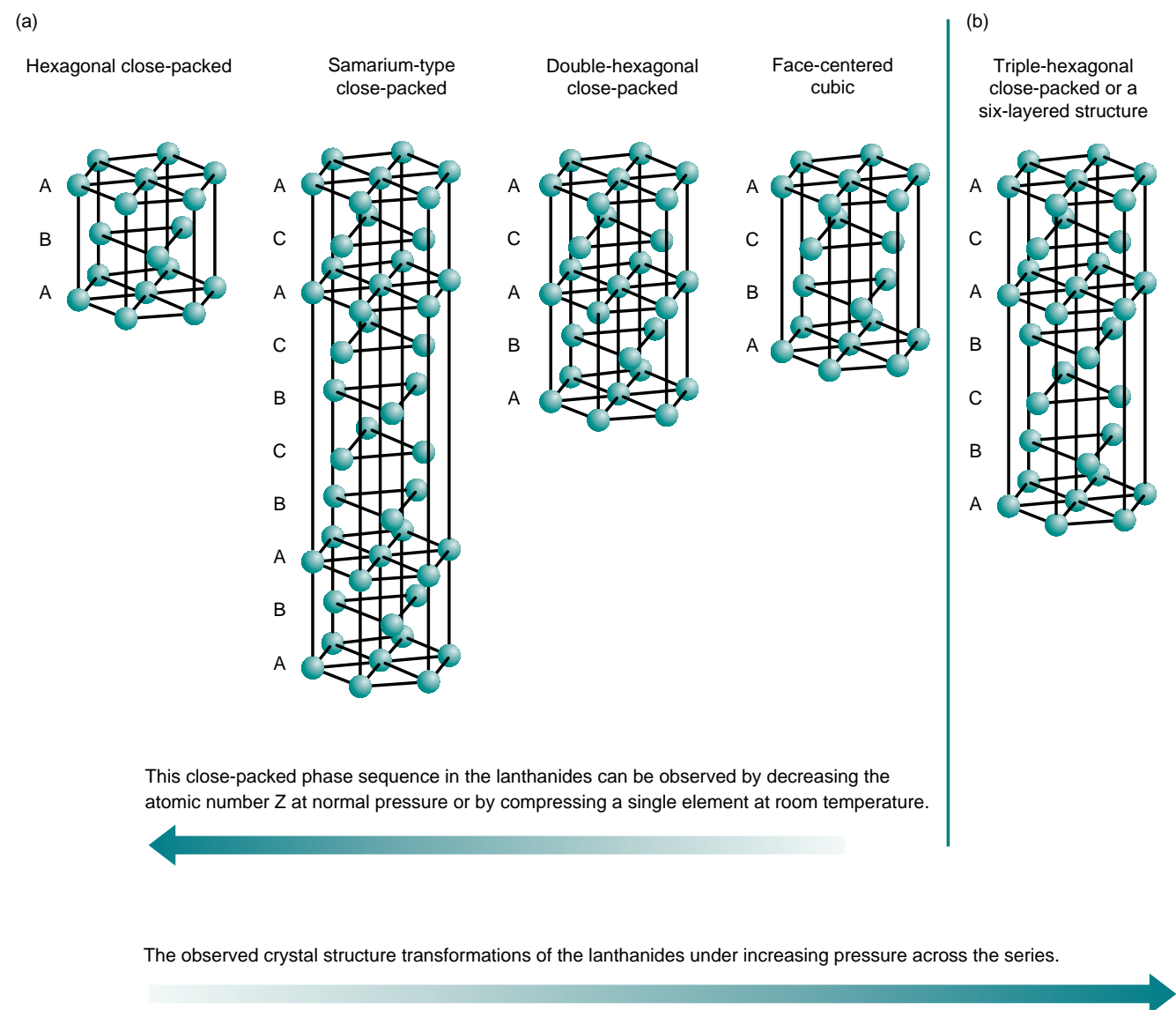

**Figure 6.** (a) The basic crystal structures found in lanthanide solids at room temperature and normal pressure across the series beginning with the lightest elements and moving to the heaviest. Our diamond anvil cell experiments have confirmed theoretical predictions that under increasing pressures approaching 100 gigapascals (GPa), the crystal lattice structure of the lanthanides follows the reverse of this sequence. In recent experiments, we saw a further transformation to a six-layered structure (b), which transforms to a body-centered tetragonal structure at pressures beyond 100 GPa but without the major volume changes predicted by some researchers. The crystal structures in (a) were first drawn by C. J. Alstetter, *Metals Transactions*, **4**, 2723 (1973).

reverse of the normal, unpressured progression pictured in Figure 6a. When we increased the pressure beyond 100 GPa, we observed that the six-layered structure further transforms to a body-centered tetragonal structure. However, we did not see any big volume changes when the lanthanides transformed from one structure to another as the pressure increased. This behavior is contrary to what other experimenters have conjectured. Thus, our data suggest that the volume of these metals changes rather smoothly as a function of pressure without big, sudden changes.

### The Actinides

In theory and in experiments, the actinides, especially the lighter ones early in the series, are less consistent in their behavior at high pressures than the lanthanides. The heavier actinides (americium through the end of the series) are predicted to behave under increasing pressures like trivalent lanthanides such as samarium and gadolinium. Our DAC experiments generally agree with theory for the heavier actinides. Thus at room temperature and pressures to 20 GPa, the trivalent lanthanides and heavy actinides studied exhibit similarities.

On the other hand, the light actinides, which include the weapons metals uranium and plutonium, are believed to behave less symmetrically and predictably under intense pressure than the lanthanides and heavy actinides. We are therefore studying them in the DAC in order to compare the electron behavior deep within them with similar behavior in the lanthanides and other actinides so that we can make critical conclusions about their high-pressure behavior.

Our findings concerning the other early actinides we have studied in depth (thorium and neptunium) illustrate the methodology and potential uses of DAC experiments for the study of uranium<sup>4</sup> and plutonium.

At room pressure and temperature, thorium has a face-centered cubic structure. In previous experimental studies to pressures below 100 GPa, we studied thorium with gold as a pressure marker. Because of the interference of the thorium and the gold diffraction lines, we did not identify phase changes in these experiments. However, our detailed investigation of thorium to 300 GPa with platinum as an internal pressure marker showed that indeed thorium goes through a structural change from face-centered cubic to a body-centered tetragonal at about 72.6 GPa with no further transformations even up to the highest pressure. Our studies also suggested significant transfer of electrons from outer shells to those deep within the atoms as the pressure increased.

Because thorium has a stable body-centered tetragonal structure even at 300 GPa and similar body-centered tetragonal structures are stable, as we have seen, for some lanthanides, LLNL researchers have asked whether the body-centered tetragonal phase is the ultimate high-pressure stable structure at room temperature for these metals. Answers to such questions are essential if theoreticians are to fine-tune their computer-generated models and code calculations.

Recent studies on the next actinide metal, neptunium, have provided answers to the question. As pressure is

increased, the orthorhombic crystal structure of neptunium at ambient conditions transforms to a body-centered tetragonal structure and then to a body-centered cubic structure that is stable to the highest pressure (see Figure 7).<sup>5</sup> This suggests that we might see similar body-centered tetragonal to body-centered cubic structural transformation in the other actinides and rare-earth metals. Thus, the ultimate stable structure of the trivalent lanthanides, the heavy actinides, and some light actinides may be body-centered cubic, not body-centered tetragonal. We also hypothesized from these studies that neptunium should have two body-centered cubic structures, one at low pressures and high temperatures before melting and another at high pressures and low temperatures. Both hypotheses provide new input to theory that can improve the precision of computer weapons code calculations.

Our classified DAC research on the light actinides uranium and plutonium has provided vital information that allows us to revise the computer modeling of the behavior of plutonium during nuclear explosions. In the absence of testing, this data is vital in assuring weapon safety, reliability, and predictability. To a lesser but equally vital extent, our DAC work on the lanthanides and other actinides related to weapons materials has contributed to those refined codes. It allows confirmation or revision of calculations derived from theory and dynamic experiments with accurate data that we can “see” from a high-pressure spectrum captured in static DAC experiments.

## Future Directions

The DAC has enabled us to obtain phase stability information that dynamic techniques such as shock-wave methods could not supply and to incorporate that information into our theoretical models. Our scientists constantly endeavor to improve DAC experimental techniques in order to obtain better data and to obtain further information about the physical properties of any material, including weapons-related materials. With the addition of a laser or a resistance heater or with cryogenic cooling, we can also use the DAC to explore the pressure–volume–temperature relationship and the resulting structural changes of any material—its equation of state and phase diagram. Higher pressure and increased temperature may force further structural changes, until the material loses its crystal structure entirely—that is, it melts.

An area of new technology for obtaining high pressure and temperature data using x-ray diagnostics is electrical transport

experiments such as ohmic heating based on resistance to the current. So far, these experiments have been among the most difficult to perform with diamond anvil cells. Special preparation of the sample, anvils, and cell is required, and electrical connections fail easily under the high stresses present in the diamond anvil cell. Consequently, electrical transport experiments have been very difficult to perform beyond several tens of gigapascals. Our scientists have developed techniques to overcome these problems and will embark on further studies of the weapons materials to still higher pressures and temperatures.

In any nuclear weapon, high explosives play a pivotal role at the time of detonation. These energetic materials generally have complex crystal structures with low symmetry and are poor x-ray diffractors. Consequently, properties that are crucial to performance—such as how the behavior of high explosives depends on increased pressure and thus on changes in crystal structure—have

not been thoroughly investigated at elevated pressures and temperatures. The DAC should allow researchers to collect such critical data under static conditions. We recently embarked on an exploratory study of equations of state and structural changes in high explosives using the DAC and synchrotron radiation. These studies will also inform us whether crystal structural changes in a high explosive such as triaminotrinitrobenzene (TATB) under pressure could cause changes in burn rates.

**Key Words:** actinides, diamond anvil cell, equations of state, lanthanides, science-based stockpile stewardship, shock-wave experiments, x-ray diffraction.

## References

1. For more information on the components of the diamond anvil cell, see "Diamonds: Powerful Tools for High-Pressure Physics," *Energy and Technology Review*, UCRL-52000-83-2 (February 1983), pp. 11–19.
2. For further information on the use of x-ray diffraction to investigate crystal structure, see "X-Ray Diffraction Applications," *Energy and Technology Review* UCRL-52000-87-11/12 (November/December 1987), pp. 23–28.
3. J. Akella, "Application of Diamond-Anvil-Cell Technique to the Study of *f* Electron Metals and Some Materials Relevant to Planetary Interiors," in *From Mantle to Meteorites*, ed. K. Gopalan, *et al.* for the Indian Academy of Sciences Press (1990), pp. 249–261.
4. Uranium has given us no help answering questions about the ultimate stable crystal structure of the early actinides under high pressure. In our diamond-anvil-cell experiments, it does not go through the phase changes at high pressures and room temperature that its neighboring elements do, and we do not yet know why.

5. Recent theoretical calculations of the structural transformations in neptunium have shown a structural sequence similar to that we found experimentally. P. Söderlind, J. M. Wills, A. M. Boring, B. Johansson, and O. Eriksson, "Theoretical Study of the Crystallographic Structures in Neptunium," *Journal of Physics: Condensed Matter* **6**, 6573–6580 (1994), and P. Söderlind, B. Johansson, and O. Eriksson, "Theoretical Zero-temperature Phase Diagram for Neptunium," *Physical Review* (January 11, 1995) (in press).

**For further information contact**  
**Jagan Akella (510) 422-7097**  
**(akella1@llnl.gov),**  
**Bruce Goodwin (510) 423-7736**  
**(goodwin2@llnl.gov), or**  
**Samuel T. Weir (510) 422-2462**  
**(weir3@llnl.gov).**

**Figure 7.** Schematic of the transformation of (a) orthorhombic neptunium at ambient temperature and pressure to (b) body-centered tetragonal to (c) body-centered cubic. The green circles in (a) represent one type of neptunium atoms, located near the corners of an orthorhombic subcell; the gray circles represent another type located near the centers of two subcells (the arrows indicate they are offset from the centers). Applying pressure moves the atoms to their nearest corner and the center of each subcell and results in (c) a smaller, more symmetric body-centered cubic form.

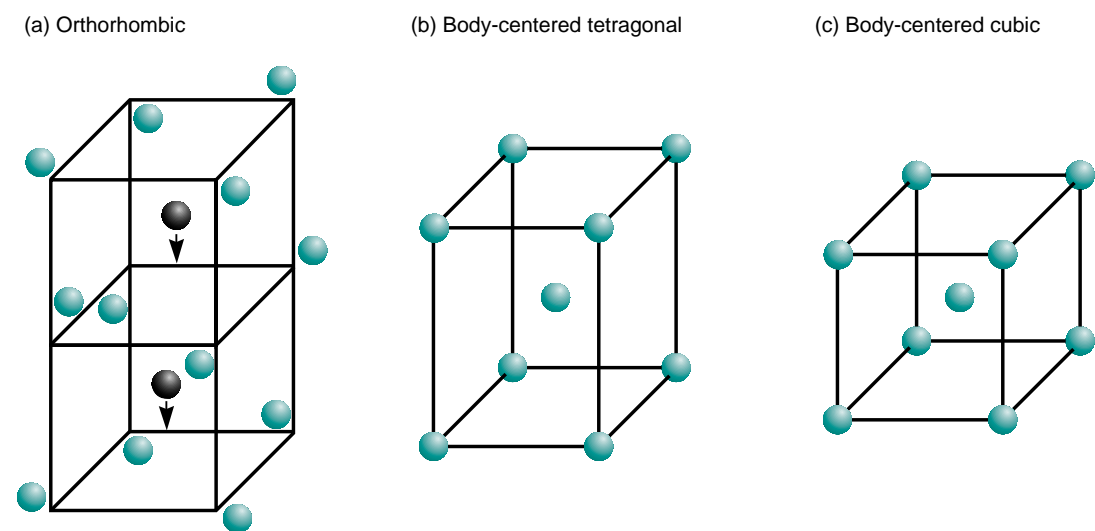

## About the Scientist



**JAGANNADHAM (JAGAN) AKELLA**, who holds a Ph.D. in geochemistry, is the principal investigator of a Lawrence Livermore project that uses the diamond anvil cell (DAC) to study the *f*-electron metals and related weapons materials under ultrahigh pressures and temperatures.

Akella has successfully used DAC technology in conjunction with synchrotron x-radiation to investigate under controlled laboratory conditions the physical and chemical behavior of highly toxic radioactive samples under ultrahigh pressures and temperatures. These investigations have improved understanding of the fission triggers in nuclear weapons. Akella is also interested in developing new DAC techniques to investigate a wide array of nuclear and nonnuclear materials. Such work is relevant to a better scientific understanding of science-based stockpile stewardship issues as well as geological phenomena.

Akella joined the Laboratory in 1977 and has published more than 80 papers covering geological sciences, condensed matter physics, and materials science. He is an elected fellow of the Mineralogical Society of America and the Indian Mineralogical Association and is one of the recipients of the Department of Energy's 1994 Weapons Recognition of Excellence awards of the nuclear weapons program.

# Getting Along without Gasoline— The Move to Hydrogen Fuel

**S**CIENTISTS and engineers from Lawrence Livermore's Energy Directorate recently found themselves on the horns of a dilemma. They had designed a concept hybrid-electric vehicle—optimized for hydrogen fuel—that meets state and federal guidelines and requirements for alternative “light-duty” vehicles (cars, vans, and small trucks).<sup>1</sup> Its acceleration ability and driving range equal or exceed those of comparable gasoline-powered vehicles, but it does not rely on imported oil and does not have the environmental drawbacks of the gasoline-powered internal combustion engine. The dilemma was that despite the team's conceptual design successes, hydrogen hybrid vehicles will not be driven in significant numbers until there is a reliable infrastructure to supply the hydrogen fuel, but neither will a hydrogen supply infrastructure develop until there is a sufficient market demand.

To resolve this dilemma, a multidisciplinary team from the Laboratory's Energy Directorate undertook a technical and economic feasibility study of the near-term potential of hydrogen transportation fuel.<sup>2</sup> It addressed four basic questions:

- Can a hydrogen vehicle compete with today's cars?
- How can hydrogen fuel be distributed to users?
- What will be the cost of hydrogen as a transportation fuel?
- How does hydrogen compare to other alternative fuels?

Furthermore, the study sought to establish a scenario for the simultaneous emergence of hydrogen-powered light-duty vehicles and a fuel-supply infrastructure to support them.

The results of the team's investigation are extremely promising. Using conservative assumptions, the investigation indicates that hydrogen-powered, hybrid-electric light-duty vehicles are technically and economically feasible solutions to the oil import and environmental problems of gasoline-powered vehicles. In addition, hydrogen is environmentally superior to any alternative fuel. Finally, the study confirms the near-term feasibility of the transition to an infrastructure for manufacturing and supplying hydrogen fuel and suggests

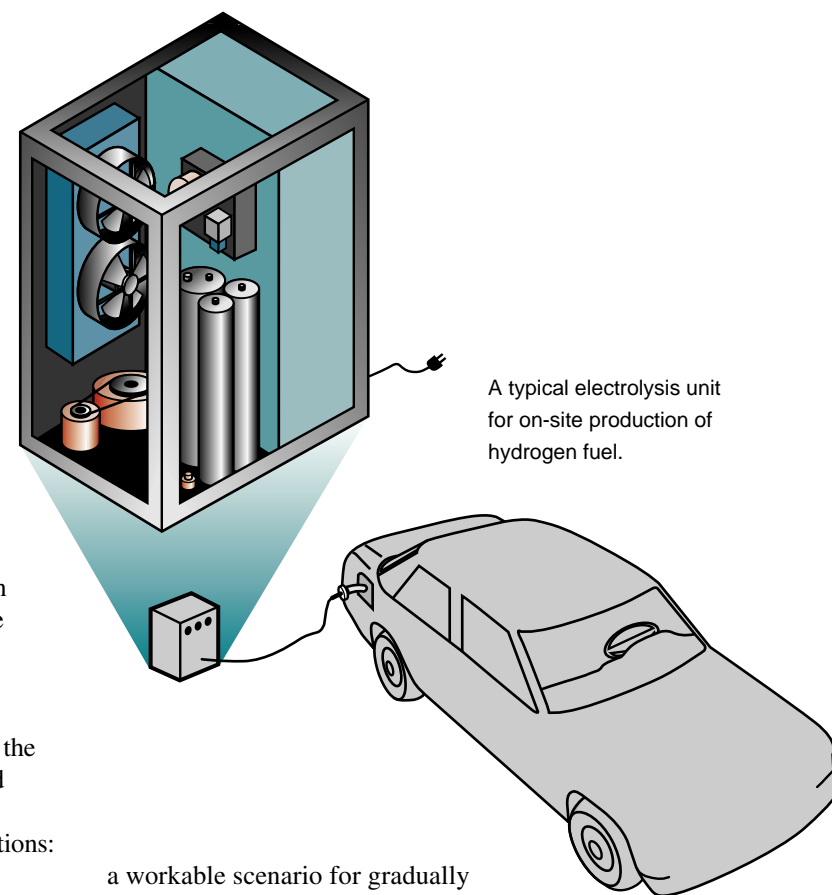

a workable scenario for gradually introducing hydrogen hybrid vehicles and the fuel to power them. The key to this feasibility is to make hydrogen at the point of use and to use the existing electric and natural gas networks to distribute the fuel.

## The Hydrogen-Fueled Concept Car

The hybrid-electric vehicle being developed at the Laboratory (Figure 1) would burn hydrogen in a small, optimized internal combustion engine to run a generator charging an electrical storage system that in turn would power an electric motor. The engine would run only as needed to charge the storage system and at optimum speed and maximum efficiency. The five-passenger vehicle is designed to accelerate from 0 to 96 km/h (60 mph) in 8 seconds and would require only about 3.75 kg

Electric drive motor: 40 kw (average power)  
Body and frame: 1,140 kg (empty weight)  
Cross-sectional area: 2.05 m<sup>2</sup>  
Regenerative braking  
Energy equivalence: 34 km/L

Primary energy conversion

30-kW optimized internal combustion engine or proton exchange membrane



Fuel storage  
(3.75-kg/480-km range)

Compressed hydrogen or liquid hydrogen or lightweight hydride



Secondary energy storage  
(2 kWh)

Advanced batteries or ultracapacitors or advanced flywheel



Figure 1. The Laboratory's hydrogen-fuel feasibility study based its analysis on a light-duty hybrid-electric vehicle with an internal combustion engine/generator or a proton-exchange fuel cell using hydrogen fuel in a variety of physical or chemical forms—e.g., compressed gas, cryogenic liquid, or hydrides. The vehicle has a 3.75-kg (8.3-lb) fuel storage capacity and a driving range of 480 km (300 miles) and gets gasoline energy-equivalent mileage of 34 km/L (80 mpg).

(8.3 lb) of hydrogen, for a 480-km (300-mile) range. It has a gasoline energy-equivalent mileage of 34 km/L (80 mpg).

The only significant emissions from the hybrid-electric vehicle would be water vapor and small amounts of nitrogen oxides, less than one-tenth the California ultralow-emission vehicle standards of 0.12 g/km (0.20 g/mile). Thus, this hybrid-electric car would qualify as an equivalent zero-emission vehicle.

The engine-generator combination in this vehicle achieves nearly the efficiency of a fuel cell\* but at much lower cost. Until fuel cells are low enough in cost to be practical, this hybrid-electric vehicle (or one similar) would be a feasible way to begin developing the mass market and infrastructure for using hydrogen fuel for light-duty vehicles. Introducing

\* A fuel cell is a means of generating electricity on board a vehicle at very high efficiency and is powered by hydrogen and atmospheric oxygen.

these hydrogen-powered vehicles and developing the infrastructure to support them would ultimately facilitate and encourage the development of fuel cells.

## Hydrogen Filling Stations

The study examined hydrogen fuel production and distribution—the supply and infrastructure issues at the heart of the dilemma about the feasibility of hydrogen-fueled vehicles. Its analysis showed that in the early stages of a transition to hydrogen, small-scale production and delivery options are feasible and that scaling up during the 20 to 30 years it will take to make the broader transition from gasoline to alternative fuel can be flexible and gradual should hydrogen turn out to be the alternative fuel of choice.



**Table 1.** A comparison of hydrogen fuel distribution technologies

Distribution technology	Vehicles supported	Economic flexibility	Relative safety	Lead time
Large pipeline (17 million kg/day)	40 million	Poor	Medium	Long
Rail	900,000	Medium	Medium	Medium
Small pipeline (100,000 kg/day)	240,000	Poor	Medium	Medium
Tanker truck	6,600	Good	Low	Short
On-site electrolysis at home or filling stations	1 vehicle to 36 million	Good	High	Short

The introduction of hydrogen vehicles does not appear to be limited by current U.S. production of hydrogen. In 1993, gaseous hydrogen production was 15.8 million kg/day (34.8 million lb/day), enough, theoretically, to fuel 44 million hybrid-electric vehicles. Currently, however, virtually all of this hydrogen is used in petroleum refining or ammonia manufacturing. Merchant hydrogen (that which is transported) accounts for a very small percentage of U.S. hydrogen production. Even so, the equivalent of today's quantities of merchant hydrogen would be enough to fuel vehicles for the first four or five years of mass production (100,000 new hydrogen vehicles per year). Hydrogen in a liquid form, currently the most cost-effective and efficient hydrogen distribution method, could fuel roughly 60,000 vehicles (using 10% of North American liquid hydrogen capacity) without additional infrastructure.

The study points out that a new hydrogen infrastructure will eventually be needed to support a mass market.

However, an expansion of today's hydrogen delivery infrastructure (liquid hydrogen by truck), which is relatively expensive and energy intensive, or the construction of a hydrogen pipeline system is probably not the answer. The alternative is to develop small-scale, local hydrogen production facilities for individual consumers, vehicle fleets, and fuel stations and to make use of the electricity and natural gas distribution networks that already exist.

Table 1 compares various hydrogen distribution technologies—especially in the early stages of the transition—in terms of scale, economic flexibility, safety, and construction lead times. It shows that on-site electrolysis, using off-peak electricity and the existing electrical infrastructure, can serve a single car or up to tens of millions of vehicles. When the number of hydrogen vehicles exceeds 40 million, additional electrical capacity could be

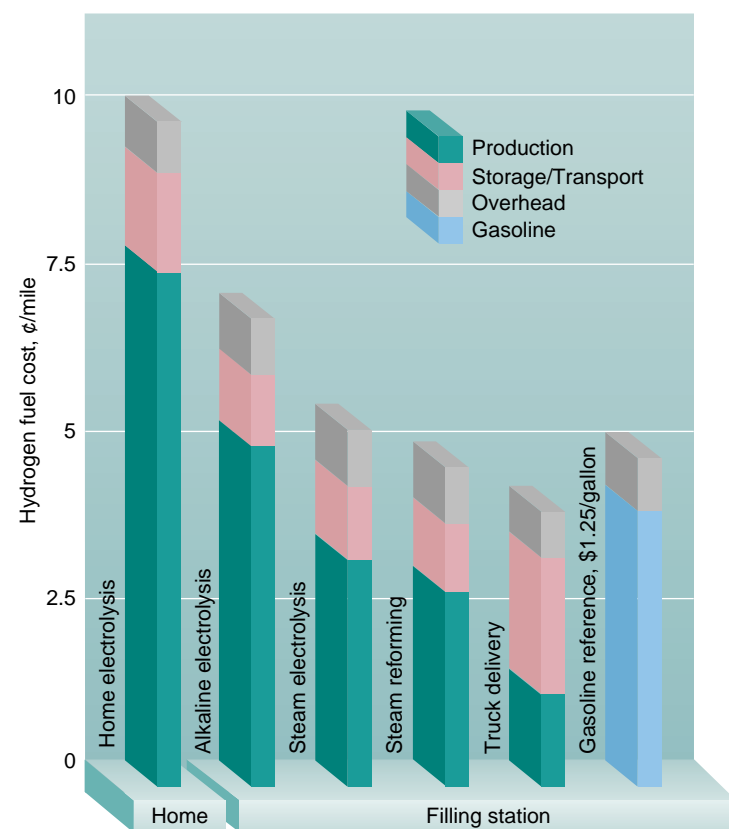

Figure 2. The per-mile cost of hydrogen fuel produced by electrolysis or steam reforming at hydrogen filling stations compares favorably with the per-mile cost for today's gasoline vehicles. (These estimates are deliberately conservative and do not include taxes on hydrogen.)

added if necessary. Approaches such as a pipeline or liquid hydrogen delivery by truck will require a large, stable hydrogen demand to justify the capital investment. Thus, the study's economic analyses suggest strongly that the transition to hydrogen can begin with small-scale production of hydrogen by off-peak electrolysis or by steam reforming at filling stations with a minimum of new infrastructure requirements and move gradually to mass-production and delivery systems.

The study also developed estimates of the cost per mile of hydrogen fuel for various production, delivery, and infrastructure scenarios (see Figure 2). The 4 to 10¢/mile cost of fueling hydrogen hybrid vehicles falls within the range of gasoline costs—today's 25-mpg car at a U.S. gasoline price of \$1.25/gallon requires 5¢/mile for fuel.

**What About the Alternatives?**

The study also compared hydrogen with other candidates to replace gasoline in alternative vehicles. The contenders, in addition to hydrogen, are electric batteries, methanol, and natural gas. Battery-powered electric vehicles would provide the highest on-board energy efficiency and, with stringent battery recycling, possibly the lowest environmental impact, but with sharp range and/or cost limitations.<sup>3</sup>

Hybrid-electric vehicles can surpass the limitations of batteries, but if natural gas (or methanol produced from it) are used to power hybrid vehicles, then domestic supply limitations and greenhouse gas emissions remain issues. These objections could be overcome by fueling hybrid-electric vehicles using methanol or hydrogen produced from organic waste. Methanol might be preferred over hydrogen because it is more easily stored and distributed. On the other hand, methanol is toxic, whereas hydrogen is not.

More persuasive, perhaps, is that when hydrogen is made from the same sources as methanol and used in similar ways, it has higher energy efficiency, fewer emissions, and lower environmental impact both in production and end use. Thermo-chemical conversion of municipal waste can be a sustainable source of hydrogen.<sup>4</sup> Electrolysis using wind or solar electricity promises to be a clean source of hydrogen fuel with even lower environmental impact than municipal waste conversion.

In comparing alternative fuels, the study concluded that hydrogen-powered vehicles could have a smoothly integrable infrastructure development and would have long-term advantages that no other fuel can match. However, it is also clear that currently there is no consensus on which fuel or fuel combination is best. Nor is there national consensus on

the monetary value and relative importance of the costs that drive the search for alternative transportation fuel, that is, the need to reduce energy imports, urban air pollution, or CO<sub>2</sub> emissions.

And yet, people in the year 2030 will live with the consequences of alternative-fuel decisions made today. Alternative-fuel vehicles and the infrastructure to support them will need to adapt to future changes in technology and to shifts in the relative importance of economic, energy security, and environmental objectives. According to the Livermore study, hydrogen fuel seems well positioned to supply the needed flexibility to the fuel supply system of the future, and its use would ensure a single, smooth, and ultimate transition from gasoline to a clean, cost-effective alternative fuel.

**Key Words:** alternative vehicles, electrolysis, hybrid-electric car, hydrogen fuel.

**References**

1. J. Ray Smith, "This Hybrid Vehicle Uses Hydrogen," *Science and Technology Review*, UCRL-52000-95-7 (July 1995), pp. 26–27.
2. Gene D. Berry, J. Ray Smith, and Robert N. Schock, *A Smooth Transition to Hydrogen Transportation Fuel*, Lawrence Livermore National Laboratory, Livermore, CA, UCRL-JC-120152 (April 1995). These study findings were reworked for submission to *Energy: The International Journal* as Gene D. Berry, et al., *Hydrogen as a Future Transportation Fuel*, Lawrence Livermore National Laboratory, Livermore, CA, UCRL-JC-117945-Rev. 1 (June 1995), and again for the LLNL report Gene D. Berry, et al., *The Feasibility of Hydrogen as a Transportation Fuel*, Lawrence Livermore National Laboratory, Livermore, CA, UCRL-JC-122167 (October 1995).
3. A Livermore advance in zinc-air fuel cells for electric fleet vehicles is featured in the October 1995 *Science and Technology Review*, pp. 6–13.
4. Lawrence Livermore scientists are exploring the use of municipal solid and other predominantly organic wastes as a feedstock for hydrogen production. With an anticipated thermal efficiency greater than 50% (heating value of hydrogen product over the heating value of feedstock), a thermo-chemical process could convert the 200 million tons of municipal waste produced annually in the U.S. to sufficient hydrogen fuel to satisfy 7% of the total U.S. transportation energy requirement. Using only half the nation's agricultural waste could satisfy the entire transportation sector. Conversion of waste to hydrogen is economically advantageous because management and disposal of wastes is expensive, and those fees become a credit against the cost of hydrogen.

**For further information contact**  
**J. Ray Smith (510) 422-7802**  
*(jrsmith@llnl.gov).*

## Patents and Awards

Each month in this space we report on the patents issued to and/or the awards received by Laboratory employees. Our goal is to showcase the distinguished scientific and technical achievements of our employees as well as to indicate the scale and scope of the work done at the Laboratory.

### Patents

Patent issued to	Patent title, number, and date of issue	Summary of disclosure
Clinton M. Logan Stephen M. Lane	<b>Air-Core Grid for Scattered X-Ray Rejection</b>  U.S. Patent 5,455,849 October 3, 1995	A grid used in x-ray imaging applications to block scattered radiation while allowing the desired imaging radiation to pass through. The grid is composed of glass containing lead oxide and eliminates the spacer material used in prior known grids. The glass is arranged in a pattern so that a large fraction of the area is open, allowing the imaging radiation to pass through.
John F. Cooper	<b>Electrochemical Mercerization, Souring, and Bleaching of Textiles</b>  U.S. Patent 5,456,809 October 10, 1995	Pollution-free treatment for textiles in a low-voltage electrochemical cell that scours, sours, and optionally bleaches without effluents or bulk caustic, neutralizing acids, or bleaches. The cell produces base in a cathodic chamber for mercerization and an equivalent amount of acid in an anodic chamber for neutralizing the fabric. Gas diffusion electrodes are used for one or both electrodes and may simultaneously generate hydrogen peroxide for bleaching.
James L. Kaschmitter Thomas W. Sigmon	<b>Solar Cells Utilizing Pulsed-Energy Crystallized Microcrystalline/Polycrystalline Silicon</b>  U.S. Patent 5,456,763 October 10, 1995	A process for producing multiterminal electronic devices using a pulsed high-energy source to melt and crystallize amorphous silicon deposited on a low-temperature substrate without excessive heating of the substrate. Dopant and hydrogenation can be added during the fabrication process. Solar cells and transistors can be made on inexpensive low temperature plastic substrates.
Thomas E. McEwan	<b>Impulse Radar Studfinder</b>  U.S. Patent 5,457,394 October 10, 1995	An ultrawideband (UWB) radar hidden-object locator that transmits a sequence of short impulses, without a carrier, and detects the reflected impulses after a fixed time period representing a fixed range. A large number of pulses are averaged, or integrated, to produce an output signal. The presence of hidden objects, e.g., studs behind a wall, produces the reflected pulses.
John C. Whitehead Lemoyne W. Dilgard	<b>Pressure Reducing Regulator</b>  U.S. Patent 5,456,282 October 10, 1995	A pressure regulator using a differential area piston arrangement with the outlet pressure referenced to a fraction of the inlet pressure. The regulator is particularly useful in pump-fed rocket propulsion systems for pressurizing the propellant tank to a small fraction of the combustion chamber pressure or gas generator pressure.
Robert J. Tench Wigbert J. Siekhaus Mehdi Balooch Rodney L. Balhorn Michael J. Allen	<b>Imaging, Cutting, and Collecting Instrument and Method</b>  U.S. Patent 5,461,907 October 31, 1995	Using an atomic force microscope with a plurality of cantilevers having a conventional pyramidal or pointed tip and/or a knife-edge tip to facilitate cutting and collecting operations. The instrument is used for collection of biological specimens, including molecules, chromosomes, and other small objects and for measuring the hardness of such objects.

### Awards

Three hundred and fifty Laboratory employees from Safeguards and Security and the Plant Engineering Directorate recently received the Department of Energy's **Energy Quality Accomplishments Awards**. **Debra Sparkman, Wendy Barzee, Joanne Smith, Tony Cole, Don Randall, Fred Glaski, Andy Stark, and Bernard Mattimore** received plaques on behalf of their organizations. Safeguards and Security and Plant Engineering competed against 29 other applicants from other DOE-related organizations in this quality awards program sponsored by the DOE Quality Council and patterned after the prestigious Malcolm Baldrige National Quality Awards.

Former Laboratory Director **John Nuckolls** has received the Department of Energy's **Distinguished Associate Award**. Vic Reis, DOE assistant secretary for Defense Programs, nominated Nuckolls for the award and presented it to him. During the ceremony, Reis noted that the award was given primarily in recognition of Nuckolls' leadership that set the groundwork for DOE's science-based stockpile stewardship program. Nuckolls has been with the Laboratory for 40 years and is currently an associate director-at-large. He is the first non-DOE employee to receive the award.

## Abstracts

### The Safe Disposal of Nuclear Waste

By the year 2010, about 63,000 metric tons of nuclear waste from commercial nuclear power reactors and 8,000 metric tons of solidified nuclear waste from defense programs are slated for permanent disposal in an underground repository. The DOE is investigating the suitability of a potential site for the nation's first high-level nuclear waste repository. For several years, LLNL has been evaluating the waste form, the performance of candidate waste package materials, and the near-field environment in which containers will function. Through a combination of laboratory tests, field tests, and models, we seek to predict the total performance of the emplaced waste and the components of an engineered barrier system surrounded by natural geological barriers, namely zeolitic rock. Federal criteria for containing and then strictly limiting the release of radionuclides from the repository are unprecedented, extending 10,000 years into the future. With further study, including modeling, computer codes, and extensive experiments to be undertaken at LLNL and at the Exploratory Studies Facility at Yucca Mountain, Nevada, we have high confidence that the system we are helping to design will protect future generations from harm for tens of thousands of years.

■ **Contact:**

**Bill Clarke (510) 423-4571 (clarke1@llnl.gov).**

### The Diamond Anvil Cell: Probing the Behavior of Metals under Ultrahigh Pressures

During the implosion of a nuclear weapon, its materials are driven inward to enormously high pressures and temperatures in order to achieve nuclear fission. The ultrahigh compressions subject the weapon materials to continual change in physical properties—volume, crystal structure, density, and the like—changes that strongly affect the course of the implosion and therefore the final yield. Weapons designers have the utmost interest in knowing exactly what those material properties are if they are to compute the performance of a device reliably. However, the great violence and brevity of a nuclear event combine to prevent the collection of precise data. Until roughly two decades ago, the only alternative to nuclear tests for measuring ultrahigh pressure and temperature properties was shock experiments. These, too, are dynamic. The diamond anvil cell enables us to test theoretical descriptions of materials of interest by exposing them to ultrahigh compressions for durations that allow us to collect complete and accurate data. The diamond anvil cell is an inexpensive way to compress tiny samples of weapons-related materials to ultrahigh pressures comparable to those at the center of the Earth in order to identify changes in their properties that can affect weapon performance.

■ **Contact:**

**Jagan Akella (510) 422-7097 (akella1@llnl.gov),  
Bruce Goodwin (510) 423-7736 (goodwin2@llnl.gov), or  
Samuel T. Weir (510) 422-2462 (weir3@llnl.gov).**

This document was prepared as an account of work sponsored by an agency of the United States Government. Neither the United States Government nor the University of California nor any of their employees makes any warranty, express or implied, or assumes any legal liability or responsibility for the accuracy, completeness, or usefulness of any information, apparatus, product, or process disclosed, or represents that its use would not infringe privately owned rights. Reference herein to any specific commercial product, process, or service by trade name, trademark, manufacturer, or otherwise, does not necessarily constitute or imply its endorsement, recommendation, or favoring by the United States Government or the University of California. The views and opinions of authors expressed herein do not necessarily state or reflect those of the United States Government or the University of California and shall not be used for advertising or product endorsement purposes.

U.S. Government Printing Office: 1996/784-071-30010