

Science & Technology

REVIEW

September 2002

National Nuclear
Security Administration's
Lawrence Livermore
National Laboratory

Shocked Organic Liquids

**Basic Science
with Dual Applications**

Also in this issue:

- **The Creative Uses of Geographic Information Sciences**
- **Optimizing Solid-Oxide Fuel Cells**
- **50th Anniversary Highlight:
A Tradition of Cutting-Edge
Laser Research**



Lawrence Livermore
National Laboratory

*Making History
Making a Difference*

1952-2002

About the Cover

A unique series of high-pressure shock experiments using one of Livermore's two-stage gas guns is exploring the possibility that the building blocks of life arrived on a young Earth by way of comets. Similar gas-gun experiments are being conducted using chemical weapon simulants to determine what might happen to the payload of an airborne chemical weapon if intercepted by another missile en route to its target. These disparate basic science projects share a fundamental concern for the fate of organic liquids subjected to strong shock compression. Turn to p. 4 for *S&TR*'s report.



Cover design: Amy Henke

About the Review

Lawrence Livermore National Laboratory is operated by the University of California for the Department of Energy's National Nuclear Security Administration. At Livermore, we focus science and technology on assuring our nation's security. We also apply that expertise to solve other important national problems in energy, bioscience, and the environment. *Science & Technology Review* is published 10 times a year to communicate, to a broad audience, the Laboratory's scientific and technological accomplishments in fulfilling its primary missions. The publication's goal is to help readers understand these accomplishments and appreciate their value to the individual citizen, the nation, and the world.

Please address any correspondence (including name and address changes) to *S&TR*, Mail Stop L-664, Lawrence Livermore National Laboratory, P.O. Box 808, Livermore, California 94551, or telephone (925) 423-3432. Our e-mail address is str-mail@llnl.gov. *S&TR* is available on the World Wide Web at www.llnl.gov/str/.

© 2002. The Regents of the University of California. All rights reserved. This document has been authored by the Regents of the University of California under Contract No. W-7405-Eng-48 with the U.S. Government. To request permission to use any material contained in this document, please submit your request in writing to the Technical Information Department, Document Approval and Report Services, Lawrence Livermore National Laboratory, Mail Stop L-658, P.O. Box 808, Livermore, California 94551, or to our electronic mail address report-orders@llnl.gov.

This document was prepared as an account of work sponsored by an agency of the United States Government. Neither the United States Government nor the University of California nor any of their employees makes any warranty, expressed or implied, or assumes any legal liability or responsibility for the accuracy, completeness, or usefulness of any information, apparatus, product, or process disclosed, or represents that its use would not infringe privately owned rights. Reference herein to any specific commercial product, process, or service by trade name, trademark, manufacturer, or otherwise, does not necessarily constitute or imply its endorsement, recommendation, or favoring by the United States Government or the University of California. The views and opinions of authors expressed herein do not necessarily state or reflect those of the United States Government or the University of California and shall not be used for advertising or product endorsement purposes.



Prepared by LLNL under contract
No. W-7405-Eng-48

Contents

S&TR Staff

SCIENTIFIC EDITOR

Kimberly S. Budil

MANAGING EDITOR

Ray Marazzi

PUBLICATION EDITOR

Dean Wheatcraft

WRITERS

Emmeline Chen, Arnie Heller,
Ann Parker, Katie Walter, and
Dean Wheatcraft

ART DIRECTOR

Amy Henke

DESIGNERS

Amy Henke and George Kitrinios

INTERNET DESIGNER

Kitty Tinsley

COMPOSITOR

Louisa Cardoza

PROOFREADER

Carolin Middleton

S&TR, a Director's Office publication, is produced by the Technical Information Department under the direction of the Office of Policy, Planning, and Special Studies.

S&TR is available on the Web at www.llnl.gov/str/.

Printed in the United States of America

Available from
National Technical Information Service
U.S. Department of Commerce
5285 Port Royal Road
Springfield, Virginia 22161

UCRL-52000-02-9
Distribution Category UC-99
September 2002

Features

3 Livermore—Poised for the Future

Commentary by Michael R. Anastasio

4 A Hitchhiker's Guide to Early Earth

Experiments examine the possibility that the building blocks of life arrived on Earth as hitchhikers on comets.

10 A New World of Maps

More than pretty pictures, maps prepared with the tools of geographic information sciences allow researchers to find new relationships among spatial information.

Research Highlight

17 Solid-Oxide Fuel Cells Stack Up to Efficient, Clean Power

The goal of Livermore's research in solid-oxide fuel cells is electric power generated cleanly and efficiently at an affordable cost.

50th Anniversary Highlight

20 Empowering Light—Historic Accomplishments in Laser Research

During the past 40 plus years, the laser program at Livermore has played a seminal role in taking high-energy lasers from concept to reality.

Departments

2 The Laboratory in the News

30 Patents and Awards

33 Abstracts

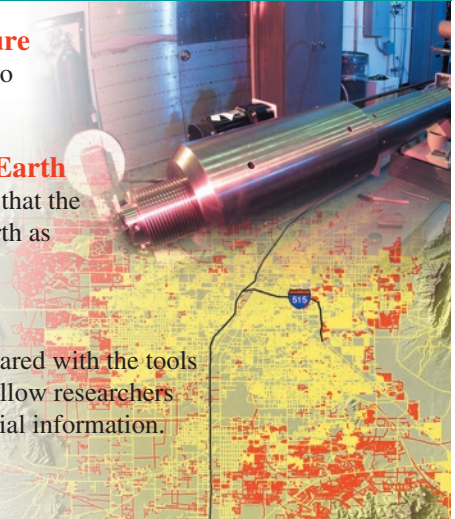

Anastasio is new Lab director

On July 1, 2002, Michael R. Anastasio became the new director of Lawrence Livermore National Laboratory. He replaces C. Bruce Tarter, who has led the Laboratory since 1995. Anastasio is the ninth director of the Laboratory. He was nominated by University of California (UC) President Richard C. Atkinson, and his appointment was unanimously approved by the UC Board of Regents in a special meeting in early June.

Anastasio, 53, has been a Livermore employee for 22 years, most recently as deputy director for Strategic Operations. He began his career at the Laboratory as a physicist in B Division, one of the two nuclear weapons design divisions within the Defense and Nuclear Technologies (DNT) Directorate. Later, as associate director of DNT, he was instrumental in the development and execution of the nation's Stockpile Stewardship Program, which is designed to sustain the safety, security, and reliability of the U.S. nuclear weapons stockpile.

Anastasio graduated from Johns Hopkins University with a bachelor's degree in physics. He earned his master's and doctoral degrees in theoretical nuclear physics from the State University of New York at Stony Brook.

In 1990, Anastasio received the Department of Energy Weapons Recognition of Excellence Award for technical leadership in nuclear design. The award acknowledges Anastasio's outstanding theoretical and experimental contributions to understanding boost physics. More recently, he served in Washington as scientific adviser at DOE, providing advice to senior members of the department on a variety of stockpile stewardship issues.

In announcing Anastasio's appointment as director, President Atkinson said that throughout his career at Lawrence Livermore, Anastasio has distinguished himself as both a brilliant scientist and skilled administrator with the right combination of theoretical and practical experience to maintain the Laboratory's historic place on the cutting edge of science.

Contact: Lynda Seaver (925) 423-3203 (seaver1@llnl.gov).

Helping cities respond to bioterrorism

Livermore scientists are developing a plan to help cities respond to chemical and biological terrorism. Sponsored by the National Nuclear Security Administration, the program will link cities by computer to the Laboratory's National Atmospheric Release Advisory Center (NARAC), which provides emergency planning response assistance to the departments of Energy and Defense.

In a chemical or biological accident or attack, city officials would send NARAC the coordinates of the toxic release. Using weather and previously gathered geographic information, NARAC scientists would map where the release is likely to spread. The information would be available to the

city within minutes and should help local emergency response workers to plan and execute response.

Working with Public Technology, Inc., a nonprofit affiliate of the National League of Cities, and with other municipal associations, NARAC scientists are demonstrating the new emergency response assistance program in Seattle, Washington. They are working with Seattle to gather information for the model and have begun testing and training exercises.

According to Donald Ermak, leader of the Livermore Atmospheric Release Assessment programs, plans call for expanding this capability to several cities and lowering the cost per city significantly. Eventually, the goal is to have a large number of cities involved, with information available to city, state, and federal officials.

Contact: Donald Ermak (925) 423-0146 (ermak1@llnl.gov).

Unique anthrax DNA signatures found

Livermore scientists working with collaborators from Salt Lake City, Northern Arizona University, and Los Alamos National Laboratory have discovered new DNA regions unique to the bacterium that causes anthrax, thereby potentially providing a way to improve the disease's detection.

At a recent meeting of the American Society for Microbiology, Livermore bioscientist Lyndsay Radnedge discussed the discovery of 20 DNA regions, or signatures, unique to *Bacillus anthracis*, the bacterium that causes anthrax.

Most DNA-based tests for *B. anthracis* use plasmid sequences, that is, a small piece of DNA separate from the chromosome and transferable between microorganisms. These sequences can be genetically unstable and yield false test results.

The new signatures increase the repertoire of chromosomal markers that can be used for anthrax detection. They are found in all of the diverse strains of *B. anthracis* in the culture collection at Northern Arizona University. They are being checked against the signatures of other strains of the bacterium and related microbes and have been found to be far different, thus eliminating the possibility of false positive or false negative results.

The DNA signatures are undergoing an extremely rigorous screening process to select the optimal signatures before being submitted to the Centers for Disease Control and Prevention in Atlanta, Georgia, for further validation.

Once primers are developed from the *B. anthracis* signatures, they can be used for rapid, specific DNA-based pathogen detection on many detection platforms, including the fast, portable ones developed by Livermore and Los Alamos scientists.

Contact: Lyndsay Radnedge (925) 423-1502 (radnedge1@llnl.gov).



Livermore Poised for the Future

THIS month marks the 50th anniversary of Lawrence Livermore National Laboratory. The world was a different place on September 2, 1952, when a branch of the University of California Radiation Laboratory opened its doors at an abandoned naval air station near Livermore, California. The fear then was the Soviet Union armed with its newly tested atomic weapon. Fifty years later, the threat of a terrorist, perhaps armed with nuclear, chemical, or biological weapons, is driving our research and development in new directions.

What has not changed in the intervening 50 years is Livermore's ability to respond to national needs. As a large multidisciplinary organization, we need to be flexible and fast on our feet. A striking example emerged early in the Laboratory's history when the Department of Defense challenged the Laboratory to miniaturize nuclear weapons. In a short time, we did the seemingly impossible and produced the warhead for the Polaris missile, the first nuclear weapon small enough to be launched from a submarine.

Today, we are responding to new and different threats. Chemical agents, bacteria, viruses, biological toxins, and genetically altered organisms could wreak havoc on urban populations, destroy livestock, and wipe out crops. These agents are often difficult to detect and identify quickly and reliably. Yet, early detection and identification are crucial for minimizing their potentially catastrophic human and economic cost. Fortunately, long before the anthrax attacks of last fall, Livermore was already a leader in developing innovative methods and technologies for early detection of chemical and biological terrorism threats. Since the attack, the Laboratory has intensified its efforts in this area so vital to national security.

Many of our successes have been achieved by teams of scientists and engineers from many disciplines that come together quickly to respond to the need at hand. This way of doing science is the legacy of the Laboratory's founder, Ernest O. Lawrence, who believed strongly that scientists from many

fields working together would accelerate the quest for fundamental knowledge. Over the past 50 years, this multidisciplinary approach has resulted in major advances in basic and applied science that in turn lead to new technologies to benefit society.

The technological accomplishments of this interdisciplinary teamwork have often yielded exciting capabilities with multiple applications to other fields. Materials developed in the weapons program have found use in artificial hip joints designed at Livermore. X-ray tomography developed to nondestructively examine the inner components of nuclear weapons has also been used to reveal the bone weakening of osteoporosis. Quantum simulations, a physics tool that can describe the fundamental interactions of weapons materials, are exposing the inner workings of biochemical processes important to human health.

The article beginning on p. 4 is an excellent example of the dual-use science at which Lawrence Livermore excels. Geophysicists, analytical chemists, and forensic scientists, collaborating on shock experiments using one of the Laboratory's gas guns, are exploring the origins of life on Earth as well as the effect of a missile intercept on chemical weapons. These subjects, which may appear to have nothing in common, are connected at a fundamental level by concern about the fate of organic liquids subjected to strong shock compression. Basic science yet again benefits national security and the world at large.

The next 50 years will undoubtedly be a period of significant changes as have the past 50 years. I am confident that Livermore's distinguished staff will continue to respond as they always have with innovation, integrity, and mission focus when called upon to meet national needs.

■ Michael R. Anastasio is director of Lawrence Livermore National Laboratory.

A Hitchhiker's Guide to Early Earth

*Icy comets crashing
into a young Earth
may have brought
the basic ingredients
for life.*



HOW on Earth did life begin? Or, more precisely, how did life on Earth begin? Theories abound, but all require the existence of basic building blocks such as amino acids to construct the earliest forms of life. One of the most exciting possible sources of these raw materials may have been the comets and asteroids that rained heavily upon Earth during its first billion years. Consequently, while life itself likely arose on Earth, the building blocks of life may well have had an extraterrestrial origin. If this cosmic origin of life's building blocks is correct, the hitchhiking organic molecules would have had to withstand the extreme pressures and temperatures of a fiery crash onto Earth's surface.

Ironically, answers to these questions about the origins of life are intimately connected to questions related to what would happen to the organic molecules of missile-borne chemical weapons if the attacking missile were intercepted by another missile. Like so many seemingly disparate subjects in science, these two are connected at a fundamental level, in this case by questions concerning the fate of organic liquids subjected to strong shock compression.

Past investigators have depended on computer modeling to determine whether the molecules could survive or be destroyed. But the limited success of these computational and theoretical approaches has underscored the long-standing need for experimental answers. Only recently have laboratory experiments been able to explore the chemistry of the extreme shock regimes associated with the delivery of amino acids to early Earth by comets or the fate of missile-borne chemical weapon agents following missile interception.

At Livermore, a team of scientists led by physicist-geochemist Jennifer Blank is conducting a series of shock experiments to explore the viability of

extraterrestrial delivery and to determine what happens to a chemical weapon's payload when intercepted by another missile. Blank says, "These experiments are the closest we can come in the laboratory to investigating the role these primordial ice balls may have played in bringing the building blocks of life to our planet or of testing the effects of missile interdiction on an incoming chemical warhead's payload."

The Livermore Connection

Blank and her team are using Livermore's 6.2-meter-long, two-stage, light-gas gun to conduct their shock experiments on organic liquids. They are focusing initially on cometary impacts. For decades, Livermore has used its gas guns to perform shock experiments on solid materials. Working with liquids in shock and recovery experiments is much more difficult than working with solids and has not been done before. "Our high-pressure-shock organic chemistry experiments are defining a new area of scientific exploration," Blank notes.

The team's experiments generate impact velocities approaching

2 kilometers per second, yield temperatures of 500 to 800°C, and produce a maximum impact pressure of 40 gigapascals (about 400,000 times atmospheric pressure). At Mach 6 speed, the gas gun's impactor smashes into a small metal capsule filled with mixtures of amino acids in water, mimicking the supersonic collision of a comet with the rocky surface of Earth.

"Right from the beginning, we knew that something had happened," says Blank. "The solution that went into the capsule was clear, and what came out was golden yellow." Through subsequent chemical analysis, the team discovered that the initial amino acids in the mixture had linked together to form peptides, from which proteins can be formed.

Cometary Matters

Life as we know it requires three essential ingredients: water, organic matter, and energy. An icy comet carrying organic material that crashes into Earth could potentially supply all of these ingredients in a single, tidy package.

An obvious question remains: Are there amino acids in comets to begin

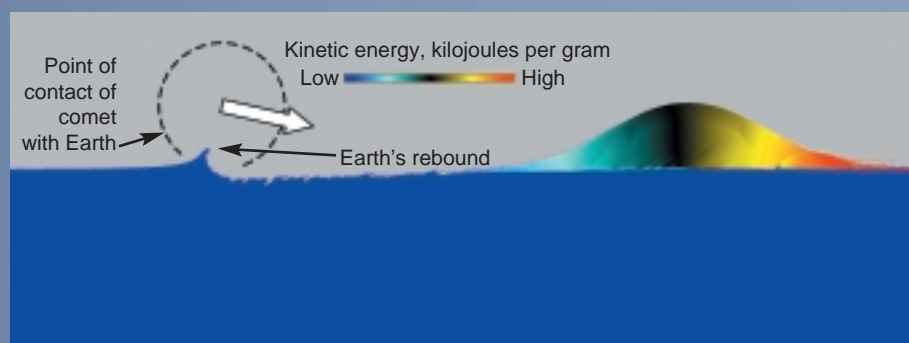

A two-dimensional simulation of an icy comet hitting the rocky Earth. This image represents the distribution of kinetic energy 678 microseconds after impact, sufficient time for the primary shock wave to pass completely through the comet. The wide distribution of energy in the comet indicates that the comet's trailing portion should be cooler—and experience lower velocity—than the front end. Thus, the rear part of the comet could arrive as a puddle of liquid water, with a high concentration of organic compounds, ready to host further chemical evolution. (Simulation by Greg Miller, Lawrence Berkeley National Laboratory.)

with? Recent experiments conducted at the National Aeronautics and Space Administration's Ames Research Center in Mountain View, California, and at a number of European research centers found that dehydrated amino acids are easy to form in laboratory simulations of interstellar clouds. Scientists do not yet know whether comets incorporate these molecules, but spectroscopic studies of comets suggest that 20 percent of their tails are organic material. Additionally, analysis reveals that meteorites landing on Earth are replete with a variety of complex organic compounds, including more than 70 different amino acids.

What has remained a mystery is the manner in which cometary organic building blocks could survive their journey to the early Earth's surface.

The figure on p. 5 shows a model of a comet smashing obliquely into a rocky Earth. As the collision occurs, the energy of the impact is distributed throughout the comet, splashing jets of material in all directions. A backward splash will have the lowest velocity relative to Earth, so this slower-moving portion would have the greatest chance of surviving as an intact puddle. The temperatures and pressures of these backward jets are also those most readily achievable in laboratory experiments.

The high temperatures created when a comet collides with Earth would certainly cause the breakdown of organic compounds trapped in the collision. However, in the fraction of the second of a strong shock impact, the extreme high pressures can impede or even prevent molecules from breaking down. A predictive theory of the organic chemistry under these extreme conditions does not exist, so

Blank and her team are exploring these uncharted regimes in the laboratory.

Shock and Recovery

The proxy for a comet in these experiments is a few drops of water and organic material contained in a 2.5-centimeter-diameter stainless-steel capsule. The team's biggest challenge has been to design a capsule capable of keeping its liquid cargo intact during the high-pressure shock loading and release.

Another challenge was to extract the material from the container after it has been smashed by a supersonic projectile. After the still warm capsule is removed from the gas-gun experiment tank, it is machined down on one side to within about 15 micrometers of the liquid inside. The capsule is then pierced with a special drill bit, and the contents are removed with a syringe.

Samples are characterized using liquid chromatography and mass spectrometry (LCMS). A portion of the sample is pushed through a chromatographic column, and as the liquid travels through the column,

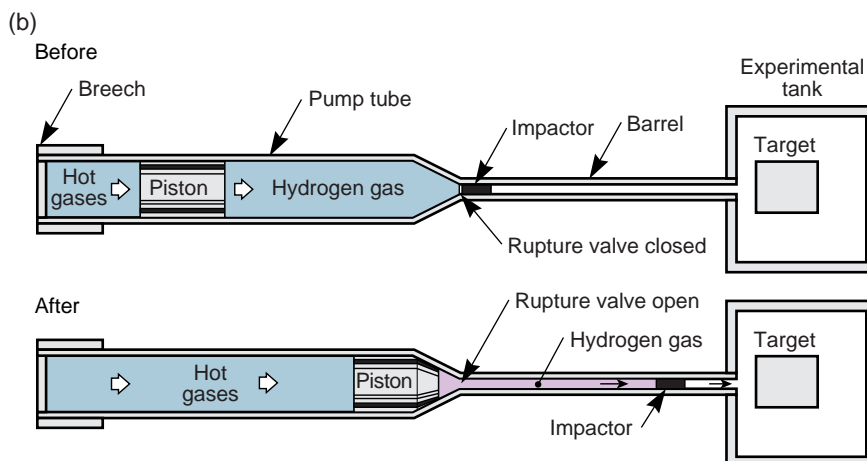

(a) A liquid sample is loaded into a capsule, which in turn will be placed into the chamber of Livermore's 6.2-meter-long light-gas gun. (b) A schematic of the gas gun in operation. A gunpowder explosion on the left pushes the piston, which pushes helium gas to open the rupture valve. The projectile then flies down the barrel of the gun to hit the target inside the gun's chamber.

different compounds separate out. (See the [figure on p. 8](#).) Mass spectrometry is then used to determine the mass of each component.

In the few dozen gas-gun experiments performed to date, from 40 to 95 percent of the initial amino acids survived. The fraction of survival depends on the impact pressure, the projectile thickness, the starting concentration of amino acids, and the structure of the amino acids.

An exciting and unanticipated discovery was the nature of the reaction products created by the impact. The dominant products are all possible pairs of the original amino acids joined together by a peptide bond, which implies that some of the energy of the impact has been harnessed to create larger organic molecules. Peptide chains composed of more than two amino acids are also produced in the experiments, though to a lesser degree.

To provide a comparison for the experimental results, Livermore physicist Nick Winter is simulating the pressure dependence of peptide formation on shock loading. Using quantum chemistry methods, Winter is developing computational models that will allow calculation of the pressure dependence of reaction rates.

Intercepting a Chemical Weapon

An allied series of experiments was performed to determine if missile-borne chemical warfare agents might survive the impact from an intercepting missile. During a missile intercept, portions of the liquid payload of chemical agent would be subjected to strong shock waves. Currently, no information is available about the chemical stability of these compounds in such a scenario. Specifically, nothing is known of the extent to which the payload might be altered as a consequence of the intercept. A substantial portion of the lethal load could be altered chemically

to nontoxic compounds by the shock, reducing the threat posed by the weapon, or the shock could increase the toxicity of the chemicals. A precise knowledge of the chemistry that would occur in an intercept is critical to the design of interception strategies and technologies.

Livermore's gas-gun experiments with simulants of various chemical warfare agents are the first of their kind. The goal is to provide laboratory evidence of whether chemical agents

might survive a missile intercept. Additionally, unique reaction products from such experiments, detectable by remote sensing methods, would constitute a simple means of determining successful intercepts.

To extract a solution after a gas-gun experiment involving chemical weapon simulants, analytical chemists Armando Alcaraz and Pete Nunes of the Forensic Science Center at Livermore use solid-phase microextraction (SPME) methods.

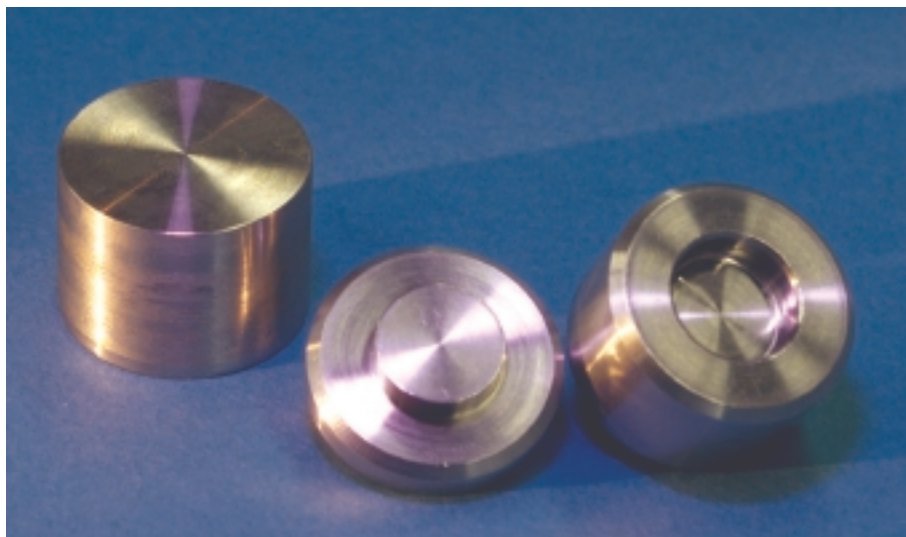

Two 2.5-centimeter-diameter experimental capsules, one (left) filled with a solution of approximately 125 microliters of liquid (amino acids in water) and ready for a shock experiment, the other open to reveal the hollow volume in the center to contain the liquid.

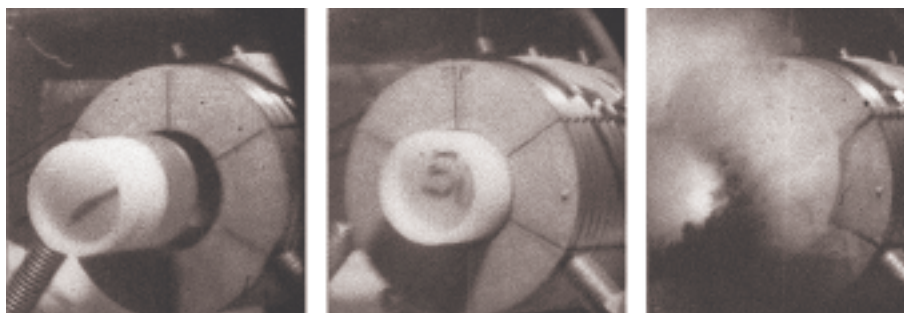

Three still images of the supersonic impactor hitting the stationary test capsule. The projectile's velocity is 0.81 kilometers per second, which is about 2,000 miles per hour. The capsule is inside the cylindrical "pig."

Using gas chromatography–mass spectrometry to characterize the solution before and after an experiment, the chemists have begun to obtain results.

“Again, we knew that something had definitely happened,” says Blank. “The solution that went in was pale yellow, and what came out looked like used motor oil.”

The Challenges of Scale

Just how real are these laboratory simulations? “Closer than one might expect,” says Blank. “The impact conditions are right on target for simulating defense scenarios. In contrast, the impact temperature of a real ice ball hitting rock would be about 15 to 30 percent higher than the 500 to 800°C attained in our current suite of gas-gun experiments.” One might think that the higher temperatures of an actual impact would destroy more of the organic material. However, the temperatures achieved in the laboratory experiments are already much higher than the thermal

stability limits of amino acids under ordinary atmospheric pressure. Hence the high survival percentages of amino acids show clearly that the destructive effects of high temperatures are buffered by the accompanying high pressures in shock waves.

Another difference between laboratory shock experiments and an actual cometary collision is the duration of the impact shocks. In the experiments, materials are shocked for only a few microseconds, while a 1-kilometer-thick ice ball hitting Earth would experience a shock wave lasting 1 second, a time difference of six orders of magnitude. The experiments assume that the comet is a single dense ball of ice. In reality, comets are known to be aggregates of much smaller objects, so this apparent discrepancy in time scales is much less severe.

The ultimate in experimental understanding will be to perform real-time spectroscopic analysis of the liquids at 100-nanosecond intervals during the shock process itself. Such measurements

are a technical challenge but would provide a more complete understanding of the physical and chemical evolution of the different reaction pathways from their onset. Obtaining such measurements is a goal that Blank and her team hope to pursue in the future by relying on techniques developed by Laboratory physicist Neil Holmes.

Such short time-scale measurements are also essential to more accurate computer models of the chemistry of high-pressure, high-temperature shock regimes. The quantity of data going into such simulations is so enormous that an accurate representation can cover only a brief period of time, typically a few nanoseconds. Thus, even the supercomputers at Livermore need another generation or two of development before these complex chemical and physical interactions over longer time periods can be simulated. Until then and until the accompanying computer codes can be developed, calibrated, and validated, scientists’

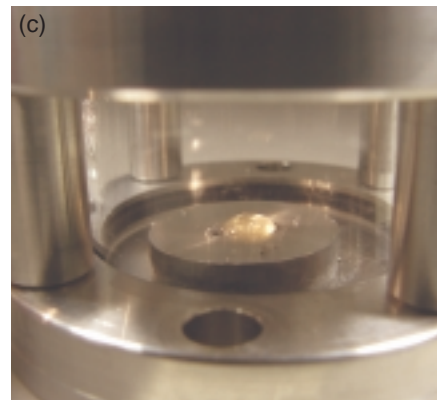
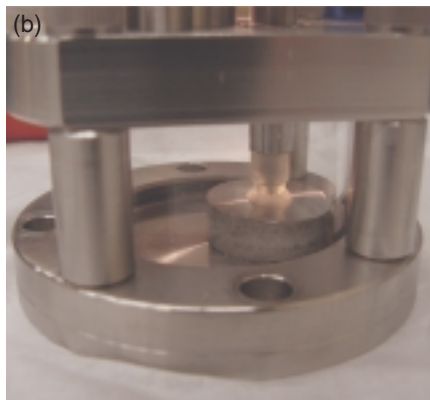
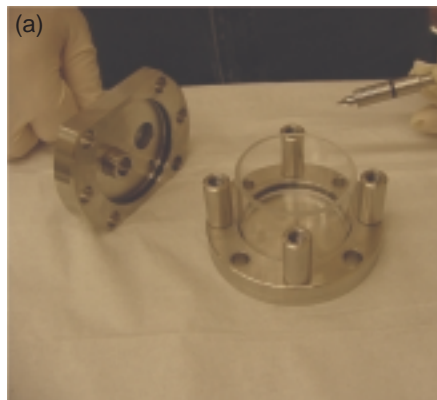

Livermore scientists have developed a new piercing device for extracting liquids under pressure in metal capsules following gas-gun shock experiments. (a) The piercing device consists of a clean glass chamber between two metal plates. The top plate has a connection for a drill bit and a silicon septum through which a needle can pass for sample collection. (b) A shocked capsule is positioned in the piercer under the drill. A Teflon sleeve around the drill bit will capture any spray that occurs when the capsule is punctured. (c) The capsule has been pierced and the drill retracted. Shocked liquid has beaded on the surface of the capsule awaiting collection.

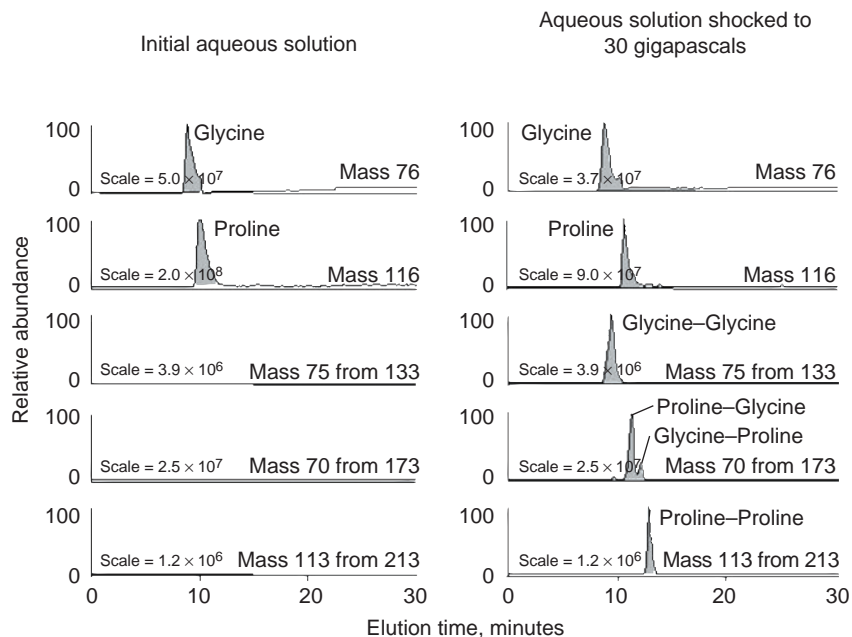

Examples of liquid chromatography–mass spectrometry spectra for a sample solution of two amino acids, glycine and proline. Peaks corresponding to the major compounds are plotted for the sample before and after it was shocked. After the liquid was shocked, some glycine and proline persist and four new compounds are present: glycine–glycine, glycine–proline, proline–glycine, and proline–proline.

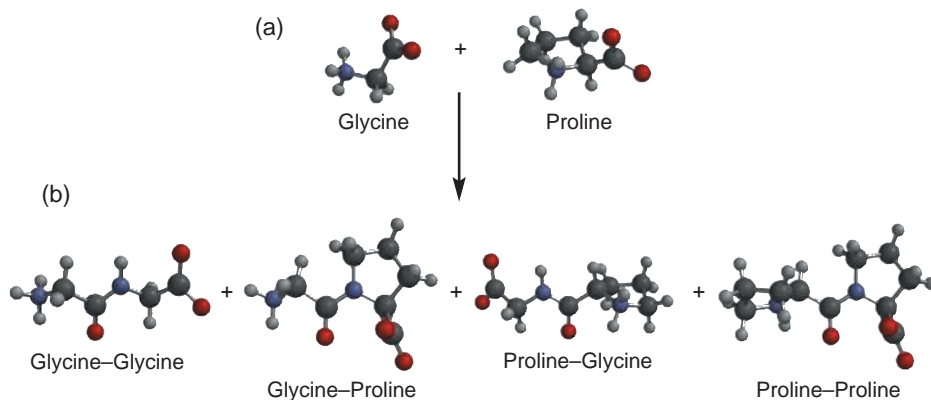

This model of dipeptide production shows that when (a) an aqueous solution bearing two amino acids, glycine and proline, is shocked, (b) four dipeptide products may result. The reaction of two amino acids to form a dipeptide is accompanied by production of a water molecule, using a hydrogen atom from one amino acid and an oxygen–hydrogen group from the other, hence the two possible forms of the glycine–proline dipeptide. (Model by Livermore physicist Nick Winter.)

knowledge and understanding depend on experiments such as those being done by Blank and her team.

At the End Is the Beginning

The Livermore research on shocked organic liquids has been much in the news lately. After all, who doesn't want to know how it all began on Earth? And in a post–September 11 world, a chemical weapon threat is an uncomfortably real possibility that must be countered effectively.

Blank is quick to make clear that the Livermore work depends on the talents of her colleagues in engineering, analytical chemistry, biochemistry, and computer modeling of hydrodynamics and quantum chemistry. Together, this team is bringing a new understanding of how it all could have started. Simultaneously, this research is providing critical information that could help to counter the threat from missile-launched chemical weapons of mass destruction.

Key Words: amino acids, astrobiology, liquid chromatography–mass spectrometry (LCMS), origins of life, shock physics, solid-phase microextraction (SPME).

For further information contact Jennifer Blank (925) 423-8566 (blank4@llnl.gov).

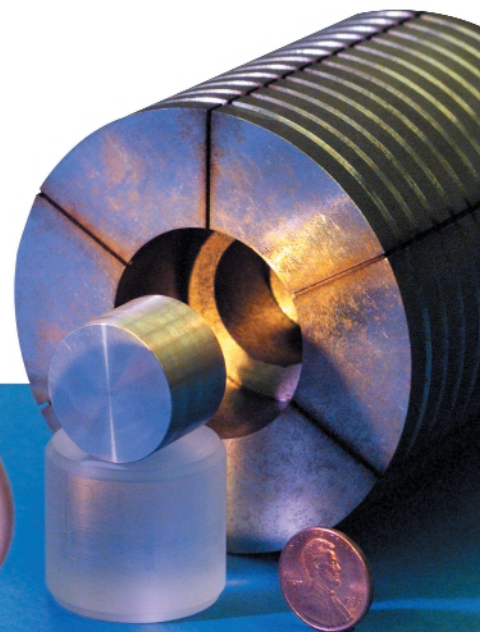

A New World of Maps

The tools of geographic information sciences help researchers to visualize, analyze, and discover new meaning in their data.

MAPS are one of society's most valuable tools. A new generation of maps, capable of housing vast amounts of data, is being created with the tools of geographic information systems (GIS). The relatively new field marries the power of computers with the ever-increasing amount of information that is geospatially based.

GIS tools organize, relate, analyze, and visualize data to help discover new meanings and insights and support important decisions. A GIS-based map can combine information that is found in hundreds of traditional maps. Data can be added with the click of a mouse, and new mixtures of data can be visualized on a screen or printed out.

What distinguishes GIS from other forms of information systems, such as databases and spreadsheets, is that GIS deals with information that is related on the basis of location, such as longitude and latitude or Global Positioning Satellite coordinates. GIS maps let users visualize this spatial information in ways not possible with spreadsheets, databases, or charts.

GIS maps are composed of superimposed layers of geographic data that allow analysts to handle and visualize large amounts of information simultaneously. There is no limit to the number of layers that can be visualized simultaneously. A user can "drill down" through data layers to discover all the data associated within a certain distance of a designated location—for example, all the schools and hospitals located within 16 kilometers of an earthquake fault line.

"GIS tools create a new visual language," says Livermore GIS analyst Lynn Wilder. She adds that researchers have jumped out of their chairs when she showed them how GIS maps allowed their research data to be almost instantly understood.

GIS has been traditionally confined to the computer screen or a printout of one or more map layers. Recently, Livermore GIS specialist Lee Neher and Web designer Marisa Price have been developing Web-based versions so researchers can access and manipulate data while working anywhere in the world.

Stunning Breadth of Applications

"The field has a stunning breadth of applications," says Charles Hall, leader of the five-year-old Livermore Geographic Information Sciences Center. The group is working with Laboratory researchers from many disciplines and has been particularly successful in combining GIS with computer models. A user can select or remove data to analyze quickly how different factors affect the model. Dave Layton, Health and Ecological Assessment division leader within the Energy and Environment Directorate, says that GIS maps aid modelers by taking advantage of the enormous amount of geospatial information that is available. Layton, who helped establish Livermore's Geographic Information Sciences Center, notes that much of the information is available from aircraft and satellite imaging. This information,

when digitized, forms one of many GIS layers.

The GIS group often supports the Department of Energy’s National Atmospheric Release Advisory Center (NARAC), located at Livermore, that models atmospheric releases. The GIS group has also mapped factors affecting international security for a number of Livermore researchers.

Closer to home, GIS analysts have done emergency planning for local governmental agencies in showing the best emergency response routes. The group has also mapped seismic activities and fault lines to help Livermore geologists and engineers understand the relationships among the occurrence of earthquakes, location of faults, surface topography, and underlying geology, which will be used to develop models of future tectonic activity.

The group built an interactive Web site for the California Energy Commission to help site future power plants. Using a menu of options

together with 30 layers of data on California, a user can request the location of prisons, canals, urban areas, railroads, watersheds, oil and gas fields, earthquake faults, and many other features, all within a specified distance. Each of the options corresponds to a separate GIS layer.

A similar Web site is being created for the federal Nuclear Regulatory Commission, which must evaluate applications for new operating licenses for nuclear power plants as well as for license renewal for each of the nation’s 103 nuclear power plants. With the click of a computer mouse, the location of endangered species, low-income populations, past hurricane and tornado routes, seismic fault lines, highways, cities, and many other factors are shown within a user-specified radius of a given power plant.

Modeling the Tallgrass Prairie

GIS tools are particularly helpful to people who do environmental and

ecologic modeling. The Geographic Information Sciences Center is helping to develop an Internet-based, interactive site to help assess the ecologic risks of oil exploration and drilling for vegetation and wildlife located in the Tallgrass Prairie Preserve in Oklahoma. The modeling project, funded by DOE’s National Petroleum Technology Office, is a collaboration among the Laboratory, Oak Ridge National Laboratory, and oil industry partners.

The reserve consists of 152 square kilometers of rolling prairie in northeastern Oklahoma and is owned by The Nature Conservancy. The reserve plays host to a variety of plant and animal species, including bison, and is one of the last substantial remnants of the tallgrass prairie ecosystem that once covered large areas of the United States and Canada. The reserve has over 600 nonworking wells and 120 active wells, and a number of oil and brine spills have occurred in the preserve over the years. As a result, says

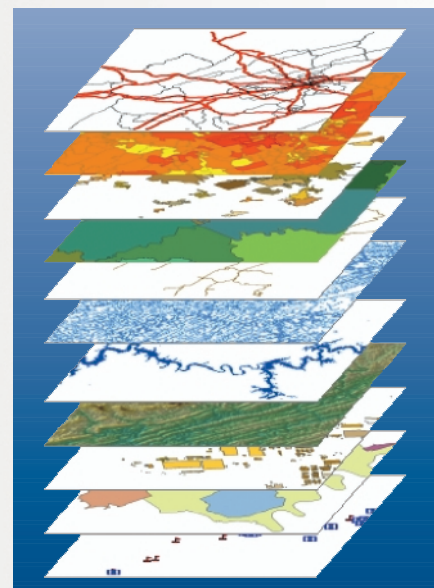
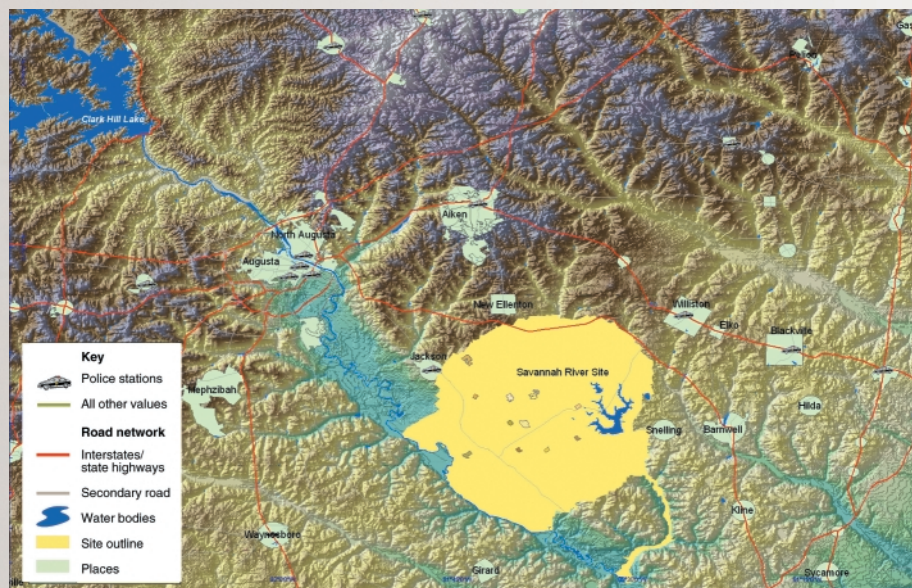

Geographic information systems (GIS) maps are composed of layers of geographically superimposed data. There is no limit to the number of layers that can be visualized. Such capabilities are particularly valuable to researchers working at the National Atmospheric Release Advisory Center, located at Livermore. In the example above, the Geographic Information Sciences Center assembled layers of data about natural and human-made features, including geography, topography, demography, roads, railroads, surface water, and facilities.

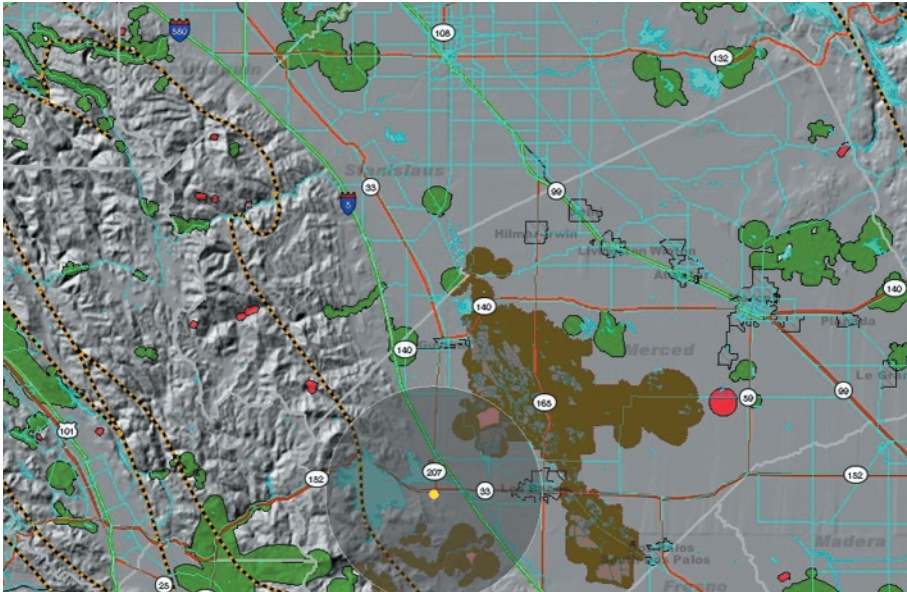

An interactive Web site built for the California Energy Commission was developed to help the state to locate sites for future power plants. Users can request to view the location of prisons, canals, urban areas, railroads, watersheds, oil and gas fields, earthquake faults, and other features, within a specified radius. This image shows selected features within 16 kilometers of a proposed power plant near Merced.

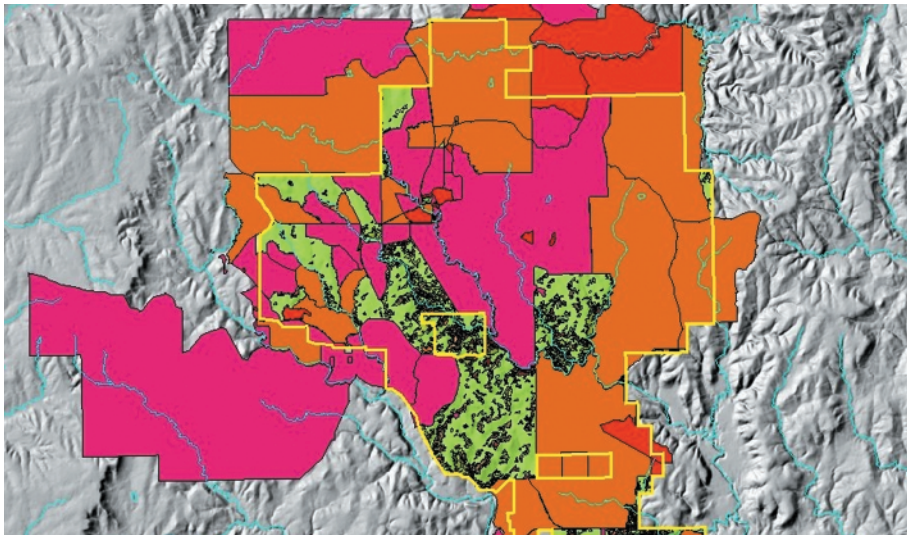

Livermore's Geographic Information Sciences Center is supporting ecologists studying the Tallgrass Prairie Preserve in Oklahoma. The center's tools allow ecologists using the Internet from anywhere in the world to access and manipulate numerous layers covering the prairie and to model hypothetical conditions in the preserve. The layers show vegetation, bison grazing areas, elevation, oil well locations, access roads, slope, drainage basins, streams, soil type, precipitation, contaminated areas, and the location of past years' prescribed burns.

Livermore ecologist Tina Carlsen, the land is characterized by small patches of contaminated or otherwise affected areas.

The project's approach takes an ecosystem perspective rather than relying on traditional organism toxicity studies. "In this project, we're working as traditional ecologists using state-of-the-art tools to determine the effects on the prairie vole and the short-eared owl of removing them from their habitat because of an oil spill or the construction of a new access road," Carlsen says.

GIS tools allow ecologists to access and manipulate numerous data layers covering the prairie as they model hypothetical conditions in the preserve. The layers show vegetation, bison grazing areas, elevation, oil well locations, access roads, slope, drainage basins, streams, soil type, precipitation, contaminated areas, and the location of past years' prescribed burns. Hall notes that this work should allow the models to run from the Web site, with the results displayed over various layers. "GIS has become essential to ecological work," says Carlsen.

Supporting Livermore's Site 300

In other environmental applications, the center is supporting the Environmental Restoration Project at Site 300, Lawrence Livermore's remote 18-square-kilometer test facility. The group has developed sets of data describing the topography, facilities, utilities, roads, groundwater contamination, population, zoning, and digitized aerial photographs. The data, organized as GIS layers, are helping researchers to place wells that extract and treat contaminants. The work also helps biologists to estimate the remedial work's effects on native species.

In another project, the group is also assisting Lawrence Livermore's Fire Department and Site 300 managers to

conduct annual prescribed burns. Such burns prevent an accumulation of wild grasses that could pose an unacceptable risk of wildfires. To understand better the atmospheric dispersion of smoke from prescribed burns at the site, NARAC researchers simulated the smoke dispersion from eight prescribed burns, four in June 1999 and four in July 2000.

The Laboratory's Fire Department provided information on the area of each burn plot, the time of ignition, the duration of the burns, how much fuel was burned, and the estimated plume heights. Using this information, the NARAC researchers estimated the smoke emission rate for each burn.

The GIS team analyzed the smoke dispersion simulations, importing the data into GIS software and then superimposing it over a satellite image of the area, which constitutes another layer. Data layers were also developed that corresponded to the location of nursing homes, schools, hospitals, day-care centers, and other facilities, called sensitive receptors, that might be affected by the smoke. Other layers corresponded to streets and highways, towns and cities, and county boundaries.

The simulations showed that for 24 hours after the burn, the simulated smoke concentrations were substantially below the legal limit of 50 micrograms per cubic meter, except directly over the burn area, as expected. Also, in no case did the simulated smoke plume drift over a sensitive receptor. NARAC meteorologist Mike Bradley says that the simulations provide persuasive evidence that the prescribed burns would cause no air quality problems. The study also confirmed that combining the modeling capabilities of NARAC with GIS provides a powerful predictive tool for evaluating the consequences of atmospheric dispersion of smoke from future prescribed burns.

Bradley is leading an effort that uses supercomputers and GIS to model wildfires more scientifically. The project, funded by the Laboratory Directed Research and Development program, combines NARAC weather prediction models with a physics-based combustion model developed at Los Alamos. Bradley is testing the model by reconstructing the early stages of the 1991 fire in the Oakland–Berkeley hills, which claimed 25 lives and destroyed 3,000 dwellings.

Hall explains that the Geographic Information Sciences Center assembles data describing topography, streets, houses, lot parcels, vegetation, transmission lines, population, and aerial imaging. Topographical and vegetation (fuel) data are fed to the

combustion model, which simulates the spread of the fire from its origin. The simulation results are displayed with GIS over the topography and lot parcels to assist in calibrating or checking the accuracy of model resolution. Eventually, this system could be used to manage vegetation, assess risks and consequences of wildfires, and plan and manage evacuation.

Salton Sea Options

One of California's most threatened ecologic systems is the Salton Sea, an inland, 644-square-kilometer saline lake in the Sonoran Desert of southeastern California. It was formed between 1905 and 1907 when the Colorado River burst through irrigation controls south of Yuma, Arizona. Over the years,

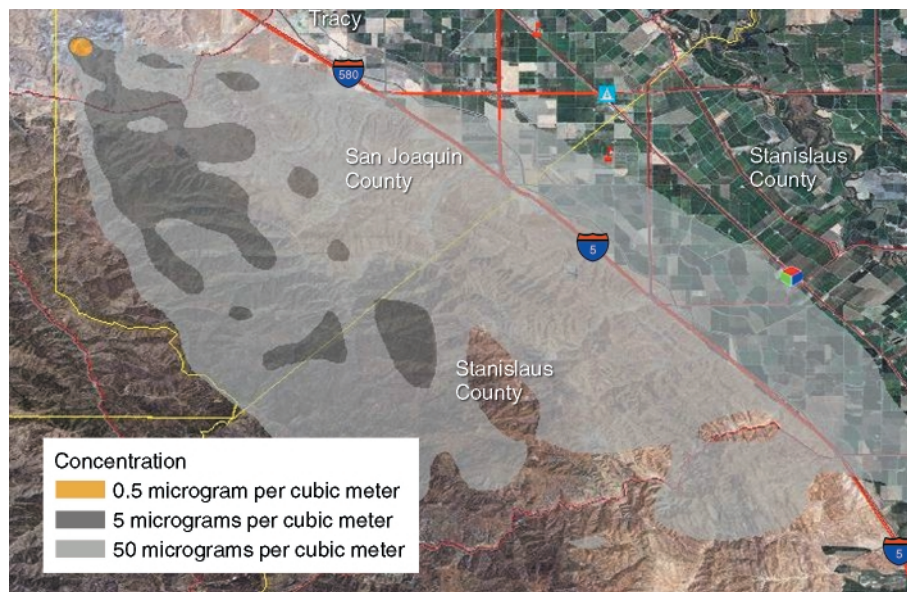

A model of the June 10, 1999, 24-hour average of smoke concentration, summed for all three controlled burns that were conducted at Livermore's Site 300. The GIS team superimposed the simulated burn data over a satellite image of the area. Data layers were developed that corresponded to local nursing homes, schools, hospitals, day-care centers, streets and highways, towns and cities, and county boundaries. The model showed that 24 hours after the burn, the smoke concentrations were substantially below the legal limit of 50 micrograms per cubic meter except, as expected, directly over the burn area. Also, the simulated smoke plume did not drift over a sensitive receptor such as a nursing home, school, or hospital.

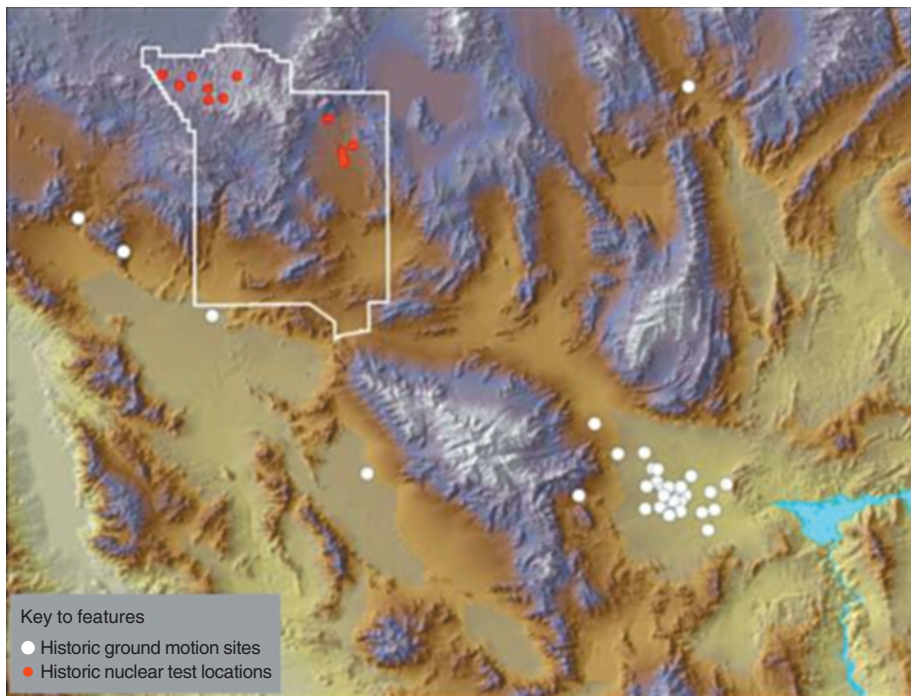

This geographic information systems image shows the locations of historic nuclear tests at the Nevada Test Site and the location of ground motion recording stations. The large number of ground motion sites in the lower right corresponds to the Las Vegas area.

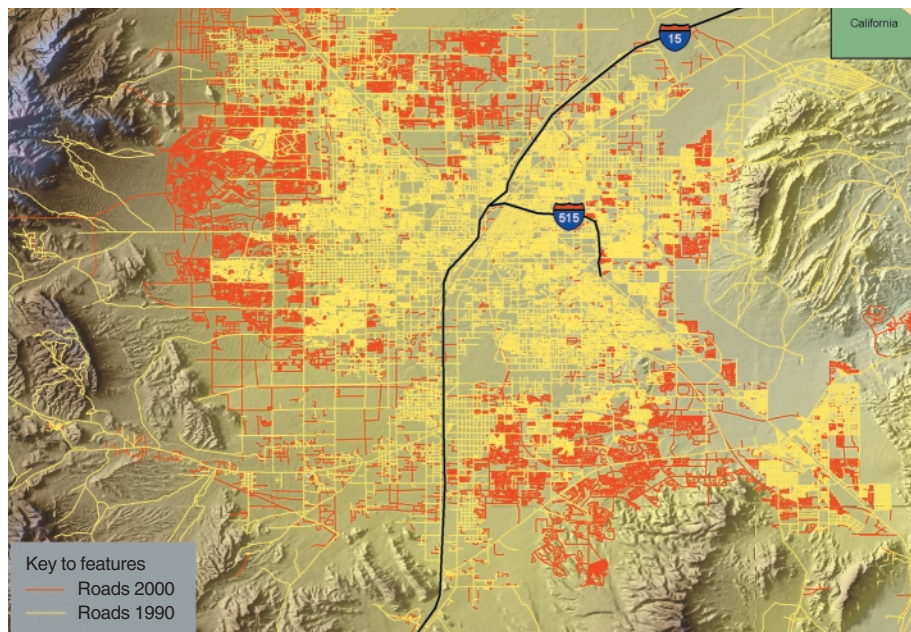

Comparison of the number of roads in greater Las Vegas, Nevada, in 1990 and 2000 reveals that significant growth occurred in the area. This image combines three layers from the geographic information systems: roads, elevation, and highways.

much water has evaporated, leaving behind high concentrations of salt.

Preventing the sea's salinity level from rising is critical to the survival of many fish and to hundreds of species of birds that eat the fish and that depend on this oasis as a wetlands habitat. Livermore researchers have been studying options to ensure that the sea has a ready supply of fresh water. At the request of Congressman Duncan Hunter of California's 52nd District, which includes a majority of the Salton Sea, the researchers met with key stakeholders in May.

The Livermore research and the presentation to stakeholders were aided by GIS maps of the sea and the surrounding area. The many-layered maps created a virtual overview of the area, with layers corresponding to canals, farmlands, cities, power plants, rivers, and elevation.

Las Vegas on the Map

GIS is playing a role in determining the seismic effects on Las Vegas if the United States had to resume underground nuclear testing at the Department of Energy's Nevada Test Site (NTS). Livermore engineer Dave McCallen is developing a computer model that shows the structural responses of Las Vegas buildings, many of them highrises constructed during the past decade. The models are based on ground motion recorded by monitoring stations located throughout the area.

McCallen notes that Las Vegas, located some 90 kilometers from NTS, lies in a sedimentary basin that traps and amplifies seismic waves. The city has experienced dramatic growth since the United States last conducted an underground nuclear test in 1992. Much of the growth has occurred in the deepest part of the basin, where no monitoring stations were sited and where the strongest ground motions might be felt from an underground blast.

Geographic Information Sciences Is Advancing Many Fields

Although the field of computer-based geographic information systems (GIS) is about 30 years old, examples in the last 150 years predicted the utility of its powerful modern versions. For example, more than 500 people, all from the same section of London, died of cholera within a 10-day period in September 1854. John Snow, a local physician, constructed a map to show the distribution of the disease. The map helped authorities to conclude that the Broad Street water pump was linked to the outbreak. By removing the pump's handle, they stopped the epidemic.

By the early 1980s, advances in computer hardware had made GIS cost-effective for many organizations. Today, GIS is growing rapidly and used by many government organizations and businesses. Some new cars are equipped with GIS and Global Positioning Satellite tools that show the driver the vehicle's exact location or the best route to a selected destination.

GIS has its origins in landscape architecture. It currently draws upon several related disciplines including cartography, cognitive science, computer science, engineering and land

surveying, biology, environmental sciences, geodetic science (methods for determining precise positions on Earth's surface), and remote sensing. GIS applications span many disciplines, including anthropology, sociology, marketing, environmental science, health sciences, biology, planning, history, geography, geology, and climatology.

Local governments use GIS to update property boundaries, site new schools and parks, and calculate emergency response times and plan the best access routes. Livermore GIS researchers have worked with California's Highway Patrol to analyze highways with high accident rates. GIS is used by businesses to identify potential markets and determine where to locate new stores. U.S. military services rely greatly on GIS tools because geography is an important factor in military action, and analysts or commanders can quickly see the effect of the terrain on possible battlefield decisions.

Livermore GIS analyst Lynn Wilder notes that new GIS tools appear every few months, thereby increasing the power and utility of the discipline but making it difficult for analysts to keep current. Increasingly, colleges are offering GIS courses.

Last fall, Wilder co-taught an introductory course at Las Positas Community College, near the Laboratory. She uses commercial software that takes at least two years to master fully. Her colleague, Lee Neher, develops software that permits users to manipulate their data with customized graphical user interfaces.

Neher says that the fields GIS can address have no limit, so long as data have an x or y coordinate. In that respect, GIS works equally well on an area of 10 square kilometers or 10 square millimeters. Livermore GIS researchers have worked on maps of the entire world as well as maps of small "worlds" of contaminants passing through rock strata.

More than 500 people, all from the same section of London, died of cholera within a 10-day period in September 1854. A map showing the distribution of the disease led authorities to close the Broad Street water pump, an action that stopped the epidemic. The map anticipated modern, vastly more complex, GIS analyses.

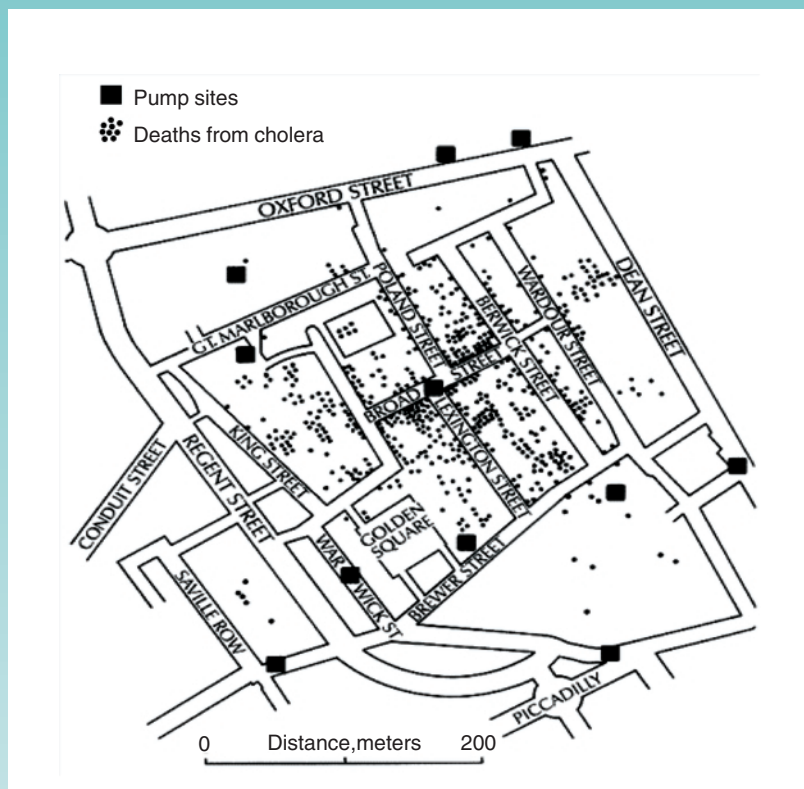

GIS maps include the entire basin and extend to NTS. The maps contain layers corresponding to streets, highways, railroads, fault lines, geology, elevation, ground motion stations, buildings, locations of past nuclear tests, and other features.

“With the GIS layers, we can see the relationship between geology and a building’s structural response,” says McCallen. “By mixing and matching the layers, we can understand a complex, large-scale problem, visualize the data, and gain insight. Without GIS, it would be difficult to get our hands around all of the data and explain our findings in a meaningful way, especially to nontechnical people.” He notes that the research spinoff to Las Vegas residents is a better understanding of the area’s general seismic hazards, especially from strong earthquakes centered in California.

GIS for Homeland Security

GIS has proved itself to be well suited to projects involving international and homeland security, especially when combined with modeling. Livermore scientists have developed two prototype programs called BIOURBAN and BIOBASE. Says Layton, “We wanted to answer two driving questions: Can we recreate the point of release and reasonably estimate the population at risk from a clandestine bioagent release days or weeks later on the basis of what

happens to a few early victims? And can we analyze a facility’s vulnerabilities to a chemical or biological release and evaluate ways to reduce the effects of an attack?”

BIOURBAN is a Web-accessible GIS-based program designed to back-calculate the point of origin of a clandestine biological release in an urban area in the U.S. and determine the size of the population at risk. The program reconstructs the probable time and location of biological agent attack from information including the location of victims, their activity patterns, the characteristics of the pathogenic organisms, disease latency, and meteorological data.

BIOURBAN contains data layers describing street and freeway networks, public places such as large arenas and auditoriums, public buildings, schools, hospitals, and mass transit systems. It can access meteorological data and dispersion models such as those used at NARAC.

A related prototype program, BIOBASE, is also Web-based. It is designed to investigate the potential vulnerabilities of a military base to chemical and biological agent attack and to evaluate alternative operating methods that could minimize exposure after such attacks.

The program uses GIS layers corresponding to roads, buildings, runways, topography, military

personnel by function, local people employed on base, dependents, and citizens living in the surrounding area. It contains a database of historic meteorological conditions and a library of simulated plumes. The program also contains a database of potential biological agents and their potency, known health effects, time until onset of symptoms, medical intervention options, and other information.

Only the Beginning

GIS is helping a growing number of Livermore researchers understand and communicate their research data. “I’m very optimistic about the possibilities of GIS,” says Hall. “At Livermore, we’re only beginning to take advantage of its capabilities.”

As NARAC researcher Bradley says, “GIS helps us to understand the meaning and significance of our data. Without GIS, it’s just a bunch of numbers or pretty plots.”

—Arnie Heller

Key Words: BIOBASE, BIOURBAN, geographic information systems (GIS), Geographic Information Sciences Center, National Atmospheric Release Advisory Center (NARAC), Nevada Test Site (NTS), Salton Sea, Site 300, Tallgrass Prairie Preserve.

For further information contact
Charles H. Hall (925) 422-0922
(hall5@llnl.gov).

Solid-Oxide Fuel Cells Stack Up to Efficient, Clean Power

FOR a growing number of power generators and users, fuel cells are the key to the nation's energy future. Clean, quiet, efficient, and compact, fuel cells generate electricity through chemistry instead of combustion. (See the [box on p. 19.](#)) As they become more widely used, fuel cells promise to help reduce global warming, air pollution, and U.S. dependence on foreign oil. No wonder, then, that interest in the advanced development and commercialization of fuel cells is at an all-time high.

Quoc Pham
at work in the
laboratory
optimizing the
solid-oxide
fuel cell.

Much of this interest is focused on four types of fuel cells—solid oxide, proton exchange membrane, molten carbonate, and alkaline. A major impediment to commercialization is the manufacturing cost. In the case of solid-oxide fuel cells (SOFCs), high manufacturing, or fabrication, costs translate into capital costs that run upwards of \$5,000 per kilowatt. In comparison, energy produced by conventional power plants has a capital cost of about \$500 per kilowatt.

Primarily because of these high costs, the Department of Energy formed the Solid State Energy Conversion Alliance (SECA) in 1999 to accelerate the development and commercialization of SOFCs. The alliance is helping researchers to discover ways to both lower fabrication costs and increase power density, that is, the power generated per area of fuel cell. SECA's goal is a modular, 3- to 10-kilowatt SOFC design that can be mass-produced and used individually or in stacks to provide power for a host of applications. In addition, the California Energy Commission (CEC) is strongly supporting the development and demonstration of fuel cells in the state.

As a committed developer of fuel cell technology, the Applied Energy Technologies Program in Livermore's Energy and Environment Directorate is helping SECA to reach its goal. Researchers in the program's Energy Conversion and Storage Technologies Group have extensive experience in developing several types of fuel cells, including the zinc-air fuel cell, the unitized regenerative fuel cell, the direct carbon conversion fuel cell, and the SOFC.

Why Solid-Oxide Fuel Cells?

SOFCs are particularly attractive because they have the highest efficiencies of any conventional fuel cell design and the potential to use many fuels—including gasoline and diesel—without expensive external reformers that create more volatile chemicals. SOFCs can operate at high temperatures, producing high-grade waste heat, or exhaust, which can be recovered and used for other applications, such as space heating and cooling, supplying homes with hot water, and even generating extra electricity by spinning a gas turbine linked to the unit. For the military, SOFCs offer the possibility of delivering quiet, clean, and uninterrupted energy to armed forces stationed in remote locations. SOFCs can also serve as auxiliary power units in motor vehicles, and leading automotive companies are already working with industrial partners to exploit their potential.



Before SOFCs can be fully commercialized, however, several technological breakthroughs are needed. A team of Livermore researchers led by materials scientist Quoc Pham is working to address the key technological challenges. Under Laboratory Directed Research and Development (LDRD) funding since 1998, the team has pursued the development of low-cost, high-power-density SOFCs that operate at temperatures below 800°C. The team's focus is developing low-cost thin-film processing techniques and optimizing materials and design to increase power density.

Lower Operating Temperatures, Higher Power Density

The current Livermore design is flat, or planar, as described in the [box on p. 19](#). Some SOFCs were originally fashioned in a tubular design, but they proved to be too expensive and had little potential for increasing power density. Livermore researchers focused on a planar design because of its potential for both higher performance and lower costs. Because a single cell has a voltage of 1 volt or less, several cells must be connected in series using electrical

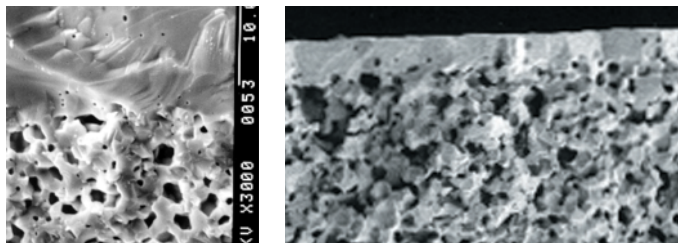

This cross section of yttria-stabilized zirconia electrolyte, imaged at different resolutions, is an example of a thin film that was deposited on a porous anode using colloidal spray deposition.

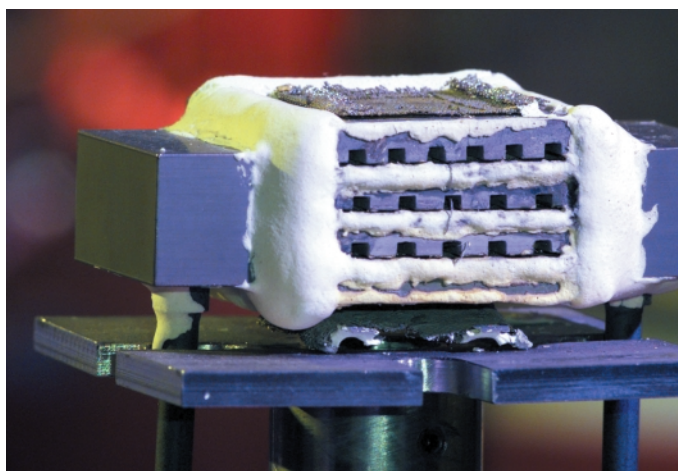

Livermore's first prototype fuel cell stack, consisting of three solid-oxide fuel cells, set a record for stack power density.

interconnections to achieve higher voltages. The complete unit is called a fuel cell stack.

SOFCs traditionally operate at extremely high temperatures (around 1,000°C). As a result, the stacks' interconnections are made of ceramic materials that are expensive and difficult to manufacture. Thus, one way to cut the fabrication cost is to reduce the operating temperature by at least 200°C, so that inexpensive alloys can be used as interconnecting materials.

The initial challenge for Pham and his team was to lower the SOFC's operating temperature without compromising the power density. The researchers first made the electrolyte layer thinner, thereby lowering the amount of resistive energy lost during operation and increasing the efficiency. The team developed a low-cost, thin-film deposition technique called colloidal spray composition, which has since been patented. This simple technique produces high-quality thin films ranging from one to several hundred micrometers thick.

The team then turned its attention to optimizing the fuel cell components. They created a multilayer fuel cell structure that features different materials to enable the use of high-performance electrodes. The structure minimizes the stress generated by the difference in thermal expansion characteristics at the interface between the electrodes and the electrolyte materials, thereby achieving a significant decrease in electrical loss. When the researchers combined the multilayer design with their thin-film deposition technique, they improved the power density of a single cell to 1.4 watts per square centimeter, one of the highest values reported for power density at 800°C.

The team then set out to demonstrate this same high power density in a stack. A three-cell stack prototype generated 61 watts, exceeding the LDRD project goal of 50 watts. The power density of the stack was 1.05 watts per square centimeter (at 800°C using hydrogen fuel), a value at least 50 percent higher than any stack power density previously reported.

The latest Livermore SOFCs operate at 700°C, a dramatic improvement. The team has received funding from the CEC to lower the operating temperature even further and to make other improvements.

The Problem of Fuel

In a separate LDRD project, Pham and his colleagues focused on streamlining the SOFC's fuel supply. Hydrogen is the preferred fuel for SOFCs, but hydrogen's high production cost and complex storage issues have made hydrocarbons such as natural gas the preferred fuels. However, methane, the main constituent of natural gas, has low reactivity, so it must be converted to more reactive products, such as carbon monoxide and hydrogen gas.

To eliminate this conversion step, which is both expensive and complex, the Livermore team explored the possibility of

directly oxidizing methane at the anode. Carbon deposition has been a major barrier to the direct oxidation of methane at SOFC anodes, but the team discovered that highly porous anodes permit direct oxidation.

Tackling Current Challenges

Although the team has addressed many SOFC issues, three major materials science challenges are preventing the

commercialization of planar SOFCs. “The planar fuel cell is a difficult design because of sealing problems,” says Pham. The biggest challenge is separating the air from the fuel, which requires that the edges of the ceramic plate be sealed.

The second challenge concerns the type of interconnection used in the fuel cell stack. Livermore’s success in lowering the operating temperature made possible the switch from ceramic to metal interconnections. At lower temperatures (below 800°C), metallic interconnects are less subject to oxidation, which leads to a loss of conductivity.

Problems with the mechanical integrity of the fuel cell stack constitute the third challenge. When brought up to operating temperature and then back to room temperature, the fuel cell stack components experience dramatic thermal and mechanical stresses. Researchers must try to minimize these stresses by both attempting to match the thermal expansions of stack components as much as possible and developing engineering designs that can accommodate the inevitable level of mismatched thermal expansion.

With CEC funding, the Livermore team has already developed potential, patentable solutions to the problems of interconnection and mechanical integrity. In total, Pham’s team has seven patents pending related to fuel cell technology.

Partnering for the Future

Once the remaining materials science problems are resolved, the team plans to construct and demonstrate a 100-watt, high-power-density SOFC, followed by construction of 500- and 1,000-watt prototypes. “After that, we can say we’ve solved the materials science issues, and our task evolves into an engineering project,” says Pham.

The team has secured several sources of funding, including support from DOE’s Fossil Energy Program. The Livermore technology is being licensed to Solid Oxide Systems, LLC (SOX), a private start-up company that is matching the CEC funding with a goal of demonstrating a 10-kilowatt system. By partnering with SOX, Pham and his colleagues hope to achieve the long-sought goal of commercializing solid-oxide fuel cell technology and fulfilling the promise of clean, highly efficient electric power at an affordable cost.

—Emmeline Chen

Acknowledgments: The work described in this highlight was done by Quoc Pham (principal investigator), Brandon Chung, Jeff Haslam, Dave Lenz, and Ervin See.

Key Words: colloidal spray deposition, energy conversion, fuel cell, fuel cell stack, high power density, multilayer fuel cell, power generation, solid oxide, Solid State Energy Conversion Alliance (SECA), thin-film deposition.

For further information contact Quoc Pham (925) 423-3394 (pham2@llnl.gov).

Solid-Oxide Fuel Cell Basics

Fuel cells are electrochemical energy conversion devices that generate electricity and heat by converting the chemical energy of fuels. Like batteries, fuel cells can be connected together in series to produce higher voltages. Fuel cells and batteries differ. A battery is an energy storage device that stores its fuel internally and that can supply only a fixed amount of energy. Reactants used in fuel cells are supplied externally, and a fuel cell has no fixed capacity—it will generate electricity as long as it is supplied with fuel and air.

Fuel cells can accept almost any kind of fuel, including natural gas, coal gas, gaseous fuels from biomass (plant materials and animal waste), and liquid fuels (gasoline, diesel), although some fuels may require preprocessing and purification. Once connected to a fuel supply, a fuel cell will produce electricity until its fuel supply is removed or exhausted.

Solid-oxide fuel cells (SOFCs) are made from solid-state materials, namely ceramic oxides. SOFCs consist of three components: a cathode, an anode, and an electrolyte sandwiched between the two. Oxygen from air is reduced at the cathode and is converted into negatively charged oxygen ions. These ions travel through the electrolyte to the anode, where they react with fuel that has been delivered to the anode. The fuel is oxidized by the oxygen ions and releases electrons to an external circuit, thereby producing electricity. The electrons then travel to the cathode, where they reduce oxygen from air, thus continuing the electricity-generating cycle. Individual cells can be stacked together in series to generate larger quantities of electricity. Within this unit, called a fuel cell stack, the cells are separated by bipolar separator planes, or interconnects.

The three components of a solid-oxide fuel cell form a modular unit that can be connected to other cells in a fuel cell stack.

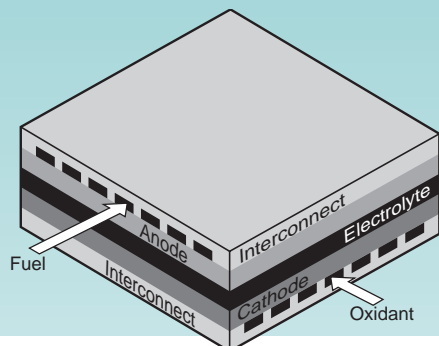

Empowering Light

Historic Accomplishments in Laser Research

**“The important thing in science
is not so much to obtain new
facts as to discover new ways
of thinking about them.”**

—Sir William Henry Bragg,
Nobel Prize for Physics, 1915

WITH the flash of the first ruby laser in 1960, a new technology was born that would come to play a major role at Lawrence Livermore National Laboratory. At the time of the laser’s first demonstration, the Livermore branch of the University of California’s Radiation Laboratory was eight years old. A moratorium on nuclear weapons testing was in effect, and Livermore’s weapon designers were deploying systems, such as the warhead for the Polaris missile, that had been tested before the moratorium took effect in 1958, and devising increasingly sophisticated computer codes to investigate the extremely complex physical phenomena involved in nuclear explosions.

The steps of an inertial confinement fusion reaction, in which more energy is produced than is used to initiate ignition. Under laboratory conditions, the sequence produces energy gain equivalent to the power of a miniature star lasting for less than a billionth of a second.

 Radiation

 Blowoff

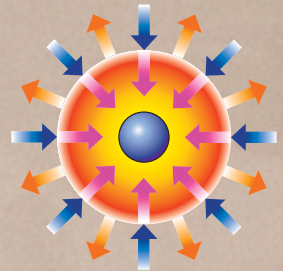
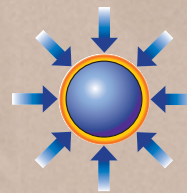

Laser beams or laser-produced x rays rapidly heat the surface of the fusion target, forming a surrounding plasma envelope.

Fuel is compressed by the rocketlike blowoff of the hot surface material.

Computations

Weapons

Engineering

Physics

Chemistry & Materials Science

The laser—with its highly coherent and focusable light—caused Livermore scientists to sit up and take notice. Several, including physicist John Nuckolls, began postulating possible uses for this amazing invention. Their musings reflected Livermore’s ongoing work in nuclear weapons design and controlled thermonuclear reaction (fusion) research. How small a thermonuclear reaction could be created in a controlled laboratory environment? Could a laser be used to create such a reaction? Such controlled reactions held out the promise of understanding better the complex interactions within nuclear weapons and the possibility of developing a new source of energy through fusion.

A Frontier Beckons

For half a century, the Laboratory has explored ways of producing energy from fusion, the nuclear reaction that powers the Sun and stars and gives nuclear weapons their awesome power. Fusion holds out the promise of providing a clean and inexhaustible source of commercial electric power production. From the start, Livermore pursued the magnetic confinement concept for producing fusion power, in which intense magnetic fields trap a plasma long enough to achieve

fusion. (See *S&TR*, May 2002, pp. 16–21.) The laser presented another option for obtaining energy from the fusion process. Shortly after the laser’s invention, Livermore used weapon design codes to study the possibility of using powerful, short laser pulses to compress and ignite a small quantity of fusion fuel composed of tritium and deuterium—two isotopes of hydrogen—in a process dubbed inertial confinement fusion (ICF).

These original calculations revealed that just heating the fusion fuel with the energy from laser light would not be enough to generate net energy, even with lasers as large as 1 million joules. To achieve energy gain—that is, more fusion energy released than energy required to initiate the fusion reaction—the laser would also have to compress the fuel to about 1,000 times its liquid density. Just scaling up existing lasers appeared no mean task, given that, at its inception, the laser’s top energy production was about 1 joule and its power about 1 kilowatt. It was also a high-risk task both scientifically and financially. A great deal of cutting-edge science and technology had to be developed at a cost difficult to estimate.

In 1962, the Laboratory started a small laser fusion project in its physics organization. The project focused on building more powerful and efficient lasers, exploring basic aspects of light–plasma interactions, and developing high-power, short-pulse lasers. Another group of physicists focused on designing fuel pellets and upgrading calculation methods. From 1962 to 1970, these early efforts produced a number of firsts including a computer program specifically designed for laser implosion calculations and a multibeam laser system for irradiating various targets. Long Path, a neodymium-doped glass (Nd:glass) laser completed in 1972, was designed to provide 40 to 50 joules of energy in 10-billionths of a second and was part of early laser and target research at Livermore.

As the decade turned, major advances in laser technology presented the possibility for high-energy systems, and new computer calculations suggested that by carefully shaping the laser pulse, targets could be ignited with less energy than originally predicted. In 1971, Laboratory Director Michael May asked Associate Director for Plans Carl Haussmann to draw all the Laboratory’s laser efforts together. (See *S&TR*, January/February 1999, pp. 4–11.) Haussmann moved swiftly

➔ Inward transported thermal energy

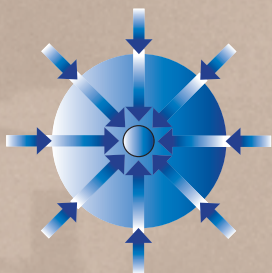

During the final part of the capsule implosion, the fuel core reaches 20 times the density of lead and ignites at 100,000,000°C.

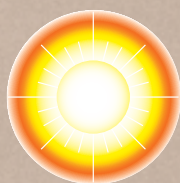

Thermonuclear burn spreads rapidly through the compressed fuel, yielding many times the input energy.

Nonproliferation



Energy & Environment



Stockpile Stewardship



Lasers



Biotechnology





The 4 pi laser system, dating from the mid-1960s, had 12 ruby laser beams arranged around a gas-filled target chamber about 20 centimeters in diameter. Physicist Frank Rainer (inset), who has been involved in laser research and development at the Laboratory since 1966, holds the target chamber seen at the center of the larger picture.

to focus Livermore's laser work. With a few phone calls and visits to the Division of Military Application at the Atomic Energy Commission (predecessor of the Department of Energy), he committed Livermore to building a 10-kilojoule laser system, the largest laser fusion facility in the country. He then brought in John Emmett and Bill Krupke—who were responsible for advanced laser research at the Naval Research Laboratory and Hughes Aircraft, respectively—to get the program up and running. The era of increasingly large and more energetic solid-state lasers at the Laboratory began.

Paving the Way with Big Laser Systems

In the early 1970s, various types of lasers were being studied for ICF: carbon dioxide, Nd:glass, hydrogen fluoride, and atomic iodine. Basic considerations of plasma physics, coupled with Livermore computer calculations, indicated to Laboratory scientists that delivering the laser energy to the target at shorter wavelengths was extremely important. Under

Hausmann and Emmett, the Laboratory decided to focus on solid-state laser systems, in which the energy in laser light is amplified in a solid material such as glass disks. For amplifiers, they chose Nd:glass, which had a relatively short wavelength in the infrared portion of the spectrum, stored energy well, and could be made in large sizes. Nd:glass amplification made for lasers with high flexibility in pulse duration, wavelength, and bandwidth.

Over three decades, the Laboratory designed and built a series of lasers, each bigger, more complex, and more powerful than the last, beginning with one that delivered 10 joules in a single beam to one that will deliver 1.8 million joules in 192 beams. (See the [box on p. 23](#).) These unprecedented projects drew on expertise from nearly every area of the Laboratory and were the basis for numerous collaborations with outside industry and the larger fusion research community. Concurrently, researchers also developed increasingly sophisticated diagnostic instruments needed for measuring and observing what was happening in the laser systems and their experiments. (See the [box on p. 25](#).)

In 1974, Livermore finished the one-beam, 10-joule Janus laser and used it to conduct the first fusion experiments at the Laboratory. It was used to demonstrate for the first time the thermonuclear reaction in laser-imploded deuterium-tritium fuel capsules. Starting in 1974, the two-beam Janus laser was used to gain a better understanding of laser-plasma physics and thermonuclear physics. It was also used to improve the LASNEX computer code, a hydrodynamics code developed in the 1970s for laser fusion predictions, which is still in use today.

The one-beam Cyclops was also completed in 1974. Its beamline was a prototype of the yet-to-be built Shiva laser. Cyclops was used as a test bed for optical designs, including those aimed at negating a nonlinear phenomena that occurs with intense light. Krupke explains, "If the intensity of the light gets high enough—as in fusion lasers—the electric field in the light perturbs the atoms of the glass so strongly that the glass responds in a nonlinear way." As a result, the beams tended to self-focus to the point of boring holes through the glass. A team of lasers scientists measured the phenomenon in glass of different compositions. In 1974, they connected their measurements to the types of measurements routinely made by glass companies to characterize their glass. "It was like the Rosetta stone," says Krupke. "With this quantitative correspondence, they were able to plot the nonlinear refractive performance of millions of glasses and find the one with the lowest possible value. We then worked with our industrial partners to make a composition with the characteristics we needed."

Laser scientists also used Cyclops to demonstrate how spatial filters could be used to remove nonlinear "noise."

The Path of a Laser Pulse

Generating enough laser energy to cause fusion, thereby simulating the physical interactions in the Sun, stars, and nuclear weapons, is an exacting process. In Livermore's National Ignition Facility (NIF), the journey begins with a weak infrared laser pulse, with energy of about 1 nanojoule and a diameter of 1 micrometer produced by the master oscillator. That pulse is amplified by the preamplifier and split into 192 pulses of 10 joules each. The pulses enter the main laser system, where each light pulse makes four passes in a beampath containing mirrors, optical switches, lenses, spatial filters, and laser amplifier glass. This multipass concept was one of the design breakthroughs of NIF. Without it, the facility would have had to be over 300 meters long for the pulses to be amplified to the required energy. Each pulse reflects off a

deformable mirror to correct for aberrations that accumulate in the beam as a result of minute distortions in the optics.

Once the beams—now 40 centimeters square—have been amplified to the required energy level (about 20 kilojoules per beam for routine operation for inertial confinement fusion experiments), they enter the switchyards where mirrors turn, or redirect, the beams into a radial, three-dimensional configuration around the target chamber. Just before entering the chamber, each pulse passes through a final optics assembly where the pulses are converted from infrared to ultraviolet light with potassium dihydrogen phosphate crystals and focused to deliver a total of 1.8 megajoules of energy to the target. Each NIF laser pulse will travel 450 meters from start to finish, a journey taking 1.5 microseconds.

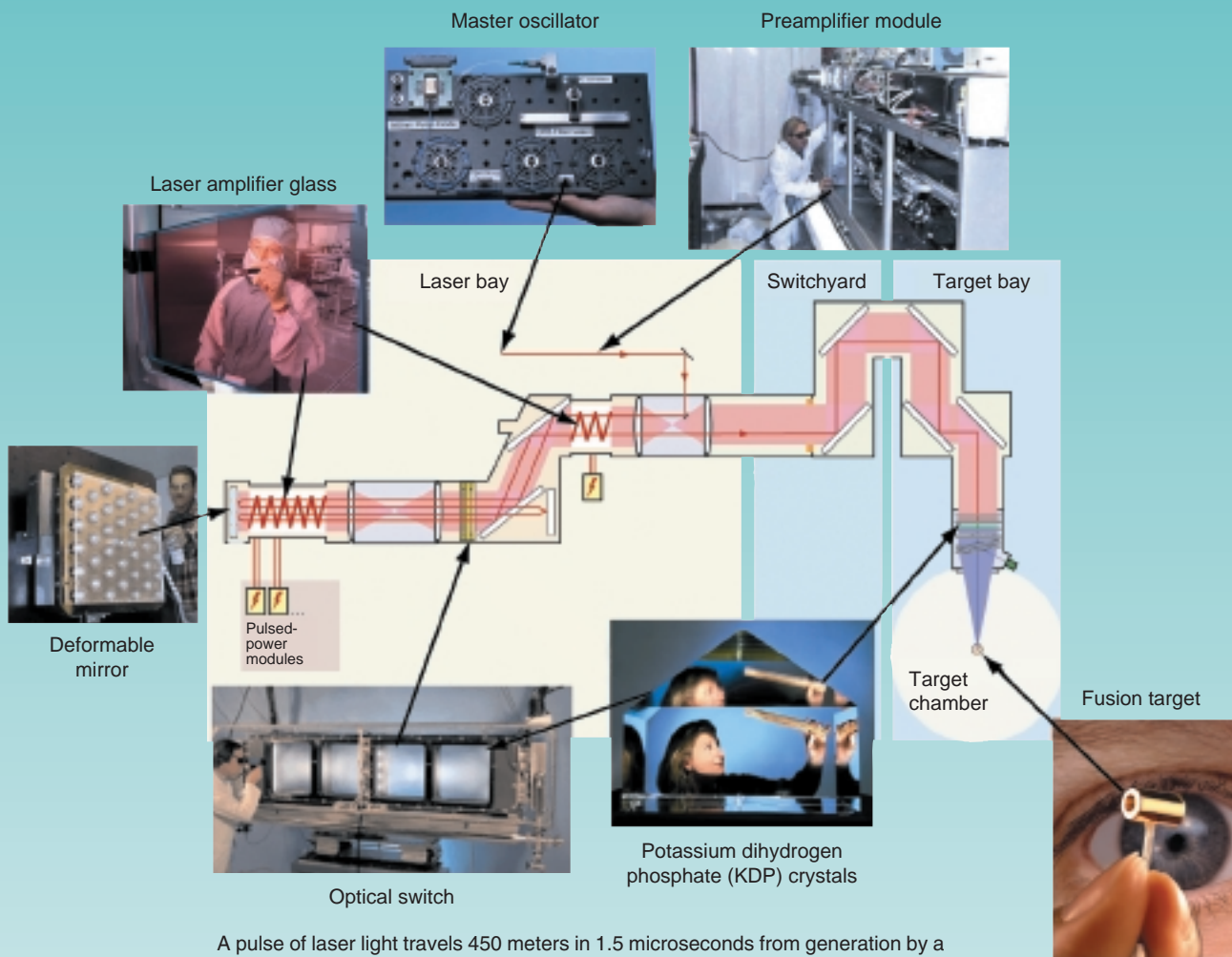

A pulse of laser light travels 450 meters in 1.5 microseconds from generation by a master oscillator to delivery on the target.

Imaging spatial filters are, in effect, small inverted telescopes inserted in laser beamlines to focus the laser light through pinholes, thus stripping away the noise, or residual nonlinear self-focusing instabilities of the beam that accumulate in the pulse during amplification. These filters essentially “freeze” the noise level of the laser beam and do not permit it to develop further. The beam can thus be relayed from one amplifier to another virtually noise-free. Janus target experiments confirmed the improved beam quality.

In 1976, the two-beam Argus came online. Use of Argus increased knowledge about laser–target interactions and laser propagation limits and helped program researchers develop technologies needed for the next generation of laser fusion systems. Argus was the first laser to have spatial filters engineered into it so that the beam could be relayed from one amplifier to another while preventing the amplification of the intensity fluctuations, or spikes, that led to optical damage known as angel’s hair, or filamentation.

The 20-beam Shiva became the world’s most powerful laser in 1977, delivering 10.2 kilojoules of energy in less than

a billionth of a second in its first full-power firing. In June 1979, Shiva compressed fusion fuel to a density of 50 to 100 times greater than its liquid density. Even more important, according to John Holzrichter, who was responsible for the laser and ICF programs at the time, Shiva proved once and for all that infrared laser light was too long a wavelength to reach fusion energy gain. Says Holzrichter, “The laser beam generates a dense plasma where it impinges on the target material. The laser light gives up its energy to the electrons in the plasma, which absorb the light. The rate at which that happens depends on the wavelength and the intensity. On Shiva, we were heating up electrons to incredible energies, but the targets were not performing well. We tried a lot of stuff to coax the electrons to transfer more of their energy to the target, with no success.”

Results from computer codes and physics theory led ICF researchers to believe that pulses of shorter wavelength were

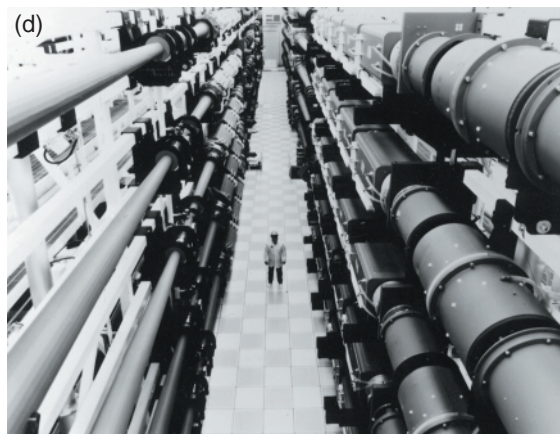
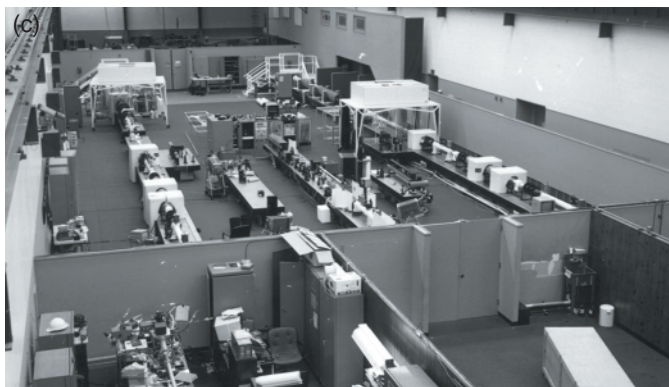
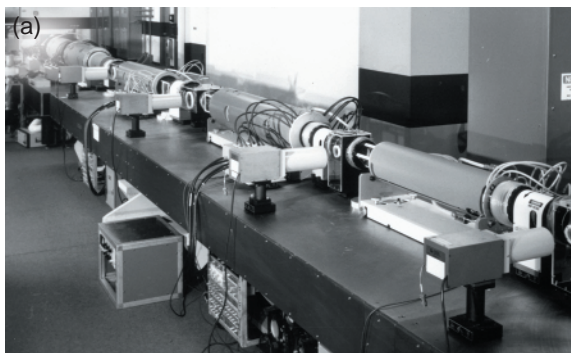

From 1973 to 1977, the Laboratory built four laser systems: (a) the one-beam Cyclops; (b) the one- and two-beam Janus system, which is still in use; (c) the two-beam Argus; and (d) the 20-beam Shiva. Each new laser provided more power and better control over the target-irradiation conditions as well as produced higher temperatures and greater compression and density in the deuterium–tritium fuel than its predecessor.

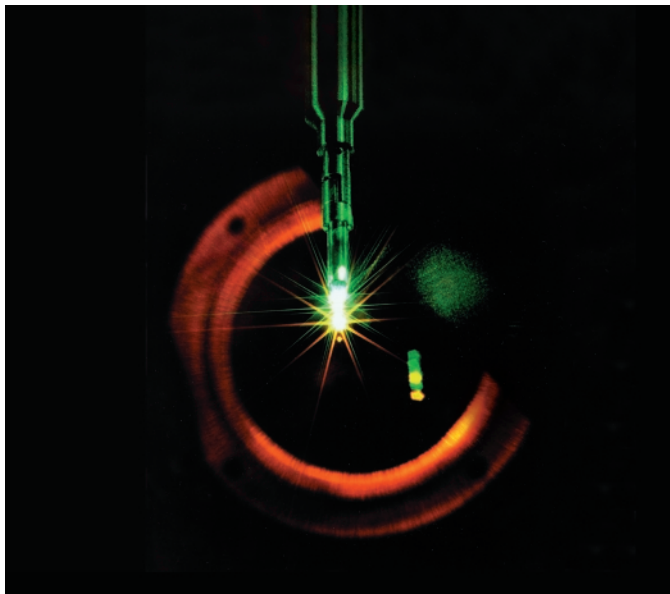

This miniature “star” was created in the Nova laser target chamber as 300 trillion watts of power hit a 0.5-millimeter-diameter target capsule containing deuterium–tritium fuel.

needed to suppress the production of these hot electrons and transfer that energy to the target. Frequency conversion crystals were added to Argus to change the laser light to a shorter wavelength, and experiments began to validate the benefits of the shorter wavelength.

Novette, which began operation in 1983, was the first laser to be engineered with optical frequency converters made of potassium dihydrogen phosphate (KDP) crystals, which converted the infrared light to shorter wavelengths. (See the [box on p. 26.](#)) Novette was a test bed and an interim target facility between Shiva and the 10-beam Nova, the next system in line.

Ten times more powerful than Shiva, Nova became the world’s most powerful laser. In 1986, Nova produced the largest laser fusion yield to date—a record 11 trillion fusion neutrons. The following year, Nova compressed a fusion fuel

Measurements Fast and Small

Experiments are all about measurement. From the beginning, those who developed lasers and conducted experiments on them have wanted to measure properties such as the shape of the laser pulse, the interactions of laser light with materials, and the physics of the target. Most of these measurements occur over brief time scales (less than billionths of a second) and short distances (micrometers) and involve measuring a variety of particles such as protons, neutrons, electrons, and photons at energies from infrared to x-ray. In the early 1960s and 1970s, diagnostic systems that could obtain information on these scales were considered extremely challenging to build and field. To develop its diagnostics, the new laser program turned to the Laboratory experts in measuring extreme conditions—the physicists, engineers, and technicians who developed and fielded diagnostics for weapons-related tests.

A variety of instruments evolved. A compact, ultrafast version of an optical streak camera helped laser designers determine whether their lasers were generating pulses of the right duration and shape. Zone plates, or coded apertures, measured alpha particle emissions, capturing the first images of alpha particles from thermonuclear burn of deuterium–tritium. X-ray streak cameras helped inertial confinement fusion (ICF) researchers define the compression physics of the ICF process. Neutron time-of-flight systems measured velocity variation in neutron bursts to help determine target performance. Photoconductive detectors measured how long fusion reactions lasted.

The National Ignition Facility (NIF) will use hundreds of cameras, detectors, and sensors to diagnose each beam from its first weak infrared pulse to its final, full-power ultraviolet configuration at the center of the target chamber. Other diagnostics that will gather information about ICF and high-energy-density experiments include the world’s fastest optical

camera, operating with an electronic shutter speed of 30-trillionths of a second, and possibly miniaturized diamond detectors to detect neutrons. Development continues on systems for experiments, including a velocity interferometer that will be used in NIF’s first physics experiment to measure the velocity of the shock wave on a foil. The experiment, scheduled for 2003, will direct the energy of four NIF beams—equivalent to the total energy of Nova—on a foil to explore the equation of state of materials.

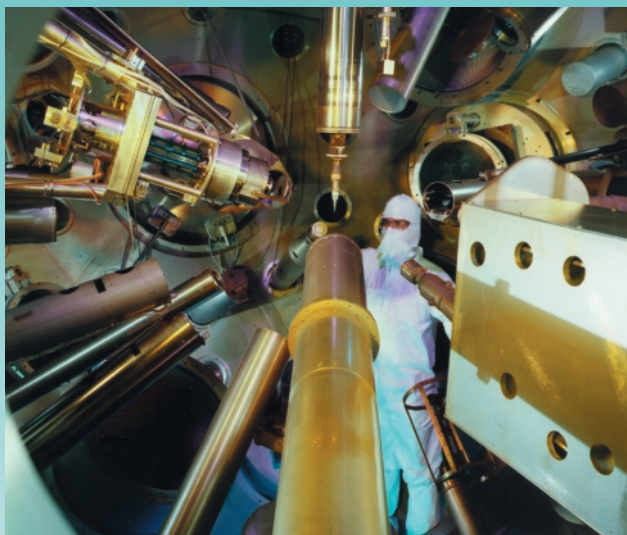

Inside the main chamber of Nova (the predecessor system to the National Ignition Facility), diagnostics surround the target mounted at the end of the rod in the chamber’s center.

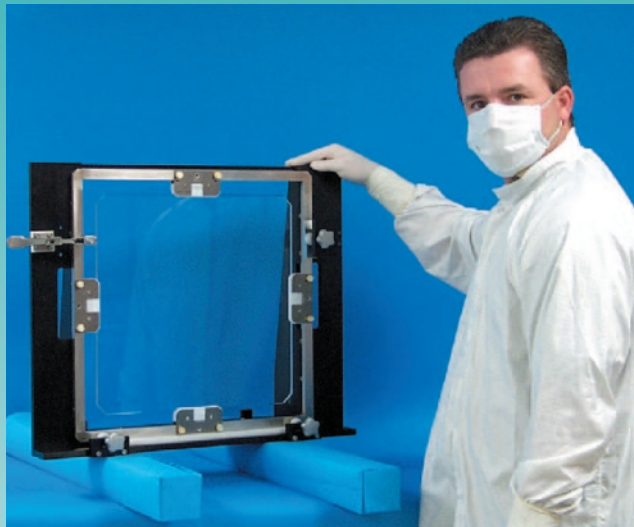

To get from the “as grown” crystal shown at the bottom of p. 23 to the finished pieces shown above—some as large as 41 centimeters across—requires precision machining and finishing. Plates sawed from the crystal are machined to the proper size and flatness before the final finishing, which is an exacting process. (See *S&TR*, January/February 1998, pp. 12–19.)

Fast-Growing Crystals

Beginning with the Argus system, thin plates of potassium dihydrogen phosphate (KDP) crystals have been used to convert the infrared laser light (at a wavelength of 1,053 nanometers, often referred to as 1-omega light) to high harmonic, shorter frequencies—green-blue (527 nanometers, or 2-omega) and ultraviolet (351 nanometers, or 3-omega).

The crystals are also used to rotate the light’s polarization for switching laser light in and out of the amplifier sections. The development of a technology to quickly grow high-quality crystals stretches back more than a decade. The fast-growth method was pioneered by Natalia Zaitseva at Russia’s Moscow State University and perfected at Livermore by Zaitseva and Laboratory scientists in the 1990s. In 1994, this effort garnered an R&D 100 Award for developing the process that produced high-quality KDP crystals for inertial confinement fusion lasers. (See *Energy & Technology Review*, November 1994, pp. 5–6.) In 1996, the team produced in only 27 days a KDP crystal measuring 44 centimeters across. (See *S&TR*, November 1996, pp. 12–20.) Under standard growing conditions, such an accomplishment would have taken up to 15 months. The following year, the Livermore team produced the world’s largest single-crystal optical element—a pyramid-shaped KDP crystal measuring about 1 meter tall and weighing nearly 180 kilograms—in 6 weeks. Previous methods would have required a growing period of 12 to 24 months to achieve the same result.

target to about one-thirtieth of its original diameter, close to that needed for ignition and fusion gain. In 1996, one arm of Nova was reconfigured as a petawatt laser. (See *S&TR*, March 2000, pp. 4–12; December 1996, pp. 4–11.) Record-setting laser shots produced pulses with more than 1.3 quadrillion watts, or 1.3 petawatts, of peak power. The laser pulse lasted less than 0.5 trillionth of a second—more than a thousand times shorter than shots typically produced by Nova’s 10 beams.

When the United States ceased nuclear testing, laser facilities became even more important for defense research, and the portion of Nova shots dedicated to the weapons program increased considerably. Researchers using Nova continued obtaining high-energy-density data necessary to validate the computer codes used to model nuclear weapons physics.

The Next Step Up

Work on Nova prepared the Laboratory to tackle construction of the 192-beam National Ignition Facility (NIF), where scientists expect to apply the lessons learned from past laser research to achieve fusion ignition and energy gain. (See *Energy & Technology Review*, December 1994, NIF special issue). Beamlet, the prototype of NIF, was also essential to demonstrating the viability of the new laser system. Operated

at the Laboratory between 1994 and 1998, Beamlet showed that the multipass laser architecture conceived for NIF was capable of meeting the fluence (energy per unit area) requirements prescribed by the National Academy of Sciences—5 to 6 kilojoules of ultraviolet energy in a 3-nanosecond pulse with a 30-centimeter beam. In August 1994, Beamlet achieved 6.4 kilojoules in a 29.6-centimeter beam. Eight months later, Beamlet improved its performance to produce 8.3 kilojoules in a 34-centimeter beam. Both of these milestones demonstrated the viability of NIF’s multipass laser architecture and other critical enabling technologies.

Groundbreaking for the stadium-size NIF took place in May 1997. (See *S&TR*, September 1999, pp. 21–23.) An extremely ambitious and technically challenging project, NIF is the culmination of 30 years of building increasingly powerful and complex Nd:glass lasers. NIF’s primary goal is to achieve ignition—a feat necessary for its role in stockpile stewardship and inertial fusion energy (IFE) development. NIF is a key component of the nation’s Stockpile Stewardship Program to ensure the safety and reliability of the nuclear deterrent and will allow weapon scientists to perform vitally needed physics experiments to validate aspects of the physics of thermonuclear weapons. Additionally, NIF will serve as a national and international center for the study of IFE and the

physics of matter under conditions of extreme temperature, energy density, and pressure.

NIF is both the largest laser and the largest optical instrument ever built, requiring 7,500 large optics (more than 30 centimeters across) and more than 30,000 small optics. The design, manufacture, and assembly of these important pieces have called for innovative ways to make optics of higher quality than ever before and to do so at unprecedented speeds and at lower cost. Livermore scientists, working with two industrial partners, met this challenge by developing the Continuous Laser Glass Melting Process. This process converts high-purity, powdered raw materials into one continuously moving strip of high-optical-quality laser glass, 1 meter long and 0.5 meter wide. This award-winning process is 20 times faster and 20 percent less expensive than the one-at-a-time process it replaces. And the resulting glass has 2 to 3 times better optical quality.

NIF is designed to deliver a total energy of 1.8 million joules of ultraviolet light to the center of a 10-meter-diameter target chamber. This energy, when focused into a volume less than a cubic millimeter, can provide unprecedented energy densities in a laboratory setting. In ICF experiments, NIF's laser beams will converge on a target containing a BB-size capsule of deuterium-tritium fuel, causing the capsule to implode and release about 10 times the energy used to drive the implosion. (See the [box on p. 29](#).) The NIF schedule calls for project completion at the end of fiscal year 2008; the NIF

team's goal is to achieve "early light" in 2003 by delivering four laser beams to the target chamber.

Other Roads Taken

In the 30 years that the Laboratory has pursued its goal of developing increasingly powerful Nd:glass lasers for basic science, energy, and nuclear weapons research, other roads have opened up, roads that sometimes have led in serendipitous directions. The innovations of Livermore's laser researchers have led, for example, to the invention of the x-ray laser in the 1980s; extreme ultraviolet lithography in the 1990s, which will soon be used to produce integrated circuits; isotope separation technology in the 1970s and 1980s; "guide stars" in the 1990s to aid ground-based astronomical observation; and numerous applications for the Department of Defense and industry.

The x-ray laser concept dates to the 1970s when physicists realized that solid-state lasers could produce high enough power to ionize x-ray laser targets. (See *S&TR*, [September 1998](#), pp. 21–23.) Livermore's Novette, the precursor of the Nova laser, was used for the first demonstration of a laboratory x-ray laser in 1984. In 1997, as a result of this research and other technical and engineering developments such as Livermore's laser isotope separation efforts, the Laboratory entered an industry-government collaboration to develop extreme ultraviolet light for making future computer chips smaller, faster, and with more storage. (See *S&TR*, [November 1999](#), pp. 4–9.) The collaboration involves Lawrence

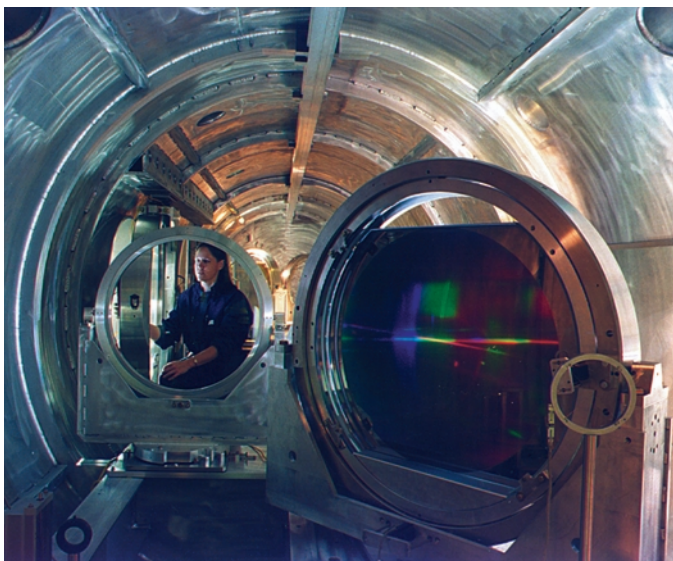

Laser physicist Deanna Pennington adjusts a diagnostic lens within the Petawatt's compressor chamber. In May 1996, the laser reached more than a petawatt (a quadrillion watts) of peak power, more than 10 times the peak power of Livermore's Nova laser.



The 10-meter-diameter target chamber of the National Ignition Facility was assembled from 18, 10-centimeter-thick aluminum sections. It is located in a 7-story target bay, weighs about 450,000 kilograms, and has been precision aligned to better than 1-millimeter accuracy.

Livermore, Lawrence Berkeley, and Sandia national laboratories and a consortium of semiconductor companies including Intel, Motorola, Advanced Micro Devices, Micron Technology, Infineon Technologies, and IBM.

In the early 1970s, many analysts were projecting that there would soon be a shortage of electricity. One option was to expand the use of fission energy, which would require an inexpensive source of enriched uranium fuel. At the same time, the inherent properties of lasers were recognized as having the potential of leading to a low-cost method to produce such fuel.

The Uranium Atomic Vapor Laser Isotope Separation (U-AVLIS) program began at Livermore in 1973 to help maintain the U.S. market share of enriched uranium fuel for the nuclear power plants that would be required to meet the world's energy needs. (See *S&TR*, May 2000, pp. 13–21.) The process used dye lasers to produce a broad and almost continuous range of colors, and an optical system selected, or “tuned,” the laser to the precise color needed to separate the desired isotope. Every isotope has a unique spectroscopic signature defined by the color of light absorbed by its atoms.

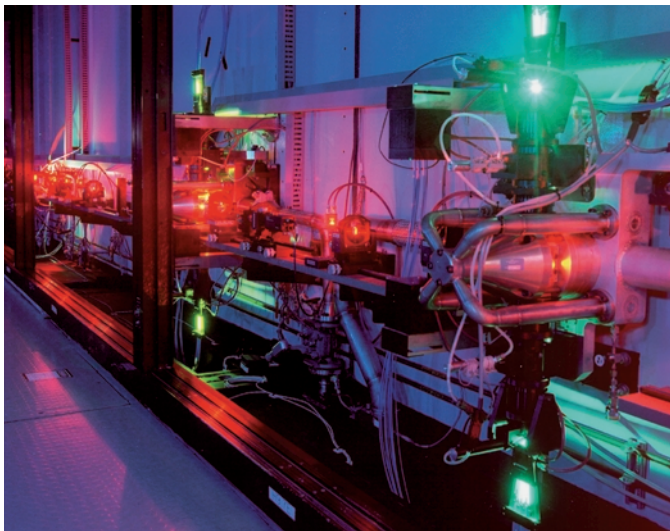

During laser isotope separation, plant-scale dye laser chains absorb green light from solid state lasers and reemit it at a color that can be tuned to the isotope of interest. In the atomic vapor laser isotope separation (AVLIS) process for uranium enrichment, green light is converted to red–orange light of three different wavelengths that are absorbed only by uranium-235. Livermore's progress in large-scale engineering development and demonstration of AVLIS for uranium enrichment led the Department of Energy in 1985 to select the technology for further development. Large-scale laser programs such as AVLIS and the Nova laser brought greater industrial involvement with advanced lasers.

By precisely tuning lasers to the color signature of a specific isotope of uranium, those atoms were selectively photoionized and then electrically separated.

Based on the success of Livermore's AVLIS program, Congress created the United States Enrichment Corporation (USEC) in 1992 to move this reactor fuel enrichment process into the private sector. By the late 1990s, however, the energy economies of the world and the need for enriched uranium had changed. USEC suspended the AVLIS program in 1999.

Laser isotope separation technology is now finding other important applications in energy, medicine, astronomy, and industry. One application uses a compact dye laser similar to that used in uranium enrichment to create a laser guide star to compensate for the effects of atmospheric turbulence that blurs the images taken by Earth-bound telescopes. (See *S&TR*, July/August 1999, pp. 12–19; June 2002, pp. 12–19.) Livermore physicist Claire Max led the team that created the first upper-atmosphere guide star at the Laboratory in 1993. Since then, the technology has been installed at several leading telescopes worldwide.

Livermore's laser researchers have also developed many Department of Defense and industrial applications from this remarkable tool over the years. For the Army, researchers have developed and demonstrated a solid-state heat-capacity laser that burned a 1-centimeter-diameter hole through a 2-centimeter-thick stack of steel plates in 6 seconds. (See *S&TR*, April 2002, pp. 19–21.) This prototype of a laser tactical weapon shows promise as the first high-energy laser compact enough in size and weight to be considered part of the Army's future combat system for short-range air defense.

On the industrial side, a team led by physicist Lloyd Hackel collaborated with colleagues at Metal Improvement Company to develop a high-energy pulsed laser system that acts as a shock-peening tool for treating metal surfaces. (See *S&TR*, October 1998, pp. 12–13.) This system, which promises to extend the service lifetime of critical metal parts, from aircraft engine fan blades to hip joints, is rapidly becoming an industrial tool for improvement of critical components. Another laser-based system imprints permanent, high-resolution identification marks that are difficult to counterfeit, can be read by machine, and strengthen the part at the site of the mark. (See *S&TR*, September 2001, pp. 8–10.)

Frontiers Beckon Bright

Throughout its years of exploration into laser systems and technology, the laser organization at the Laboratory has contributed breakthrough after breakthrough. In the last five years alone, Livermore has been responsible for the world's most powerful laser (the Petawatt in 1996), the brightest (JanUSP in 1999), and the largest (the National Ignition Facility, under construction). The future beckons bright.

Focusing on Targets

One NIF target design resembles a typical Nova target, but at 2 millimeters in diameter, it will be four times bigger and will contain a layer of frozen deuterium-tritium to help achieve conditions supporting ignition. (See *S&TR*, July/August 1999, pp. 4–11.)



For nearly 30 years, researchers have explored and refined the design, production, and performance of targets for Livermore's Inertial Confinement Fusion Program.

Current target design efforts build upon thousands of experiments on Nova and predecessor laser systems, which led to an ever-increasing capability in target design and fabrication, diagnostic instrumentation, and computer simulation as well as a firmer grasp of physics issues affecting ignition. Computer modeling has always been an important tool for exploring target design options at Livermore. Because no single code can simultaneously model all ignition phenomena, researchers today

use several Livermore-developed codes, including the radiation hydrodynamics codes LASNEX, HYDRA, and F3D, which simulate the interactions of the laser light with the electrons and ions in the plasma. Target design continues to evolve, and researchers are exploring target designs not only for the National Ignition Facility but also for inertial confinement fusion power plants of the future. (See *S&TR*, November 2001, pp. 24–26.)

(a) The direct-drive target, a small capsule containing deuterium-tritium fuel, is uniformly illuminated from all directions

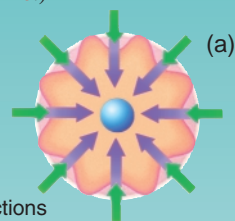

by laser beams. (b) The indirect-drive target has an outer metal cylinder of gold or lead containing a plastic fusion capsule. Laser beams enter the cylinder, or hohlraum, through holes at its end caps and hit the inside surface where the energy is converted to x rays. The x rays heat and ablate the capsule surface, causing a rocketlike pressure on the capsule and forcing it to implode.



For instance, a NIF short-pulse initiative, funded by the Laboratory Directed Research and Development program, shows promise in obtaining extremely bright x-ray sources for stockpile stewardship experiments. Another area of research involves diode-pumped lasers, which may provide nearly continuous high-energy laser operation for fusion power production. (See *S&TR*, September 1996, pp. 4–11.) And, of course, NIF and beyond.

About NIF, George H. Miller, associate director for NIF Programs notes, "MIT physicist Sam Ting [Nobel Prize for Physics, 1976] has been quoted as saying no big facility is ever known for the thing that it was originally designed to do. The people learning to use facilities come up with ideas and inventions that were never conceived of by those who first put the facilities together. So I can't possibly guess what NIF is going to be known for 15 years from now, much less 30 years from now. But one of the things I do know is that NIF is going to be an absolutely remarkable machine in terms of its flexibility, its power, its ability to do the kind of quality experiments that are just going to excite and challenge all varieties of science."

—Ann Parker

Key Words: 4 pi laser, atomic vapor laser isotope separation (AVLIS), Beamlet, Cyclops, Continuous Laser Glass Melting Process, direct-drive target, extreme ultraviolet lithography, hohlraum, indirect-drive target, inertial confinement fusion (ICF), Janus, laser guide star, laser peening, LASNEX, Long Path, National Ignition Facility (NIF), neodymium-doped glass (Nd:glass), Nova, Novette, Petawatt, potassium dihydrogen phosphate (KDP) crystals, Shiva, solid-state heat capacity laser, spatial filters, x-ray laser.

For more information about the National Ignition Facility Programs Directorate:

www.llnl.gov/nif/

For details about the history of lasers at Livermore:

www.llnl.gov/timeline/

For further information about the Laboratory's 50th anniversary celebrations:

www.llnl.gov/50th_anniv/

Each month in this space we report on the patents issued to and/or the awards received by Laboratory employees. Our goal is to showcase the distinguished scientific and technical achievements of our employees as well as to indicate the scale and scope of the work done at the Laboratory.

Patents

Catheter Guided by Optical Coherence Domain Reflectometry

Matthew Everett, Billy W. Colston, Luiz B. Da Silva,

Dennis Matthews

U.S. Patent 6,384,915 B1

May 7, 2002

A guidance and viewing system based on multiplexed optical coherence domain reflectometry is incorporated into a catheter, endoscope, or other medical device to measure at discrete points on the device the location, thickness, and structure of the arterial walls or other intracavity regions during minimally invasive medical procedures. The information will be used both to guide the device through the body and to evaluate the tissue through which the device is being passed. Multiple optical fibers are situated along the circumference of the device. Light from the distal end of each fiber is directed onto the interior cavity walls via small-diameter optics such as gradient index lenses and mirrored corner cubes. Both forward-viewing and side-viewing fibers can be included. The light reflected or scattered from the cavity walls is then collected by the fibers and multiplexed at the proximal end to the sample arm of an optical low-coherence reflectometer. The system may also be implemented in a nonmedical inspection device.

Coherent Beam Combiner for a High Power Laser

C. Brent Dane, Lloyd A. Hackel

U.S. Patent 6,385,228 B1

May 7, 2002

A phase-conjugate laser mirror using Brillouin-enhanced four-wave mixing allows multiple independent laser apertures to be phase locked, producing an array of diffraction-limited beams with no piston-phase errors. The beam combiner has application in laser and optical systems requiring high average power, high pulse energy, and low beam divergence. A broad range of applications exists in laser systems for industrial processing, especially in the field of metal surface treatment and laser shot peening.

Birefringence Insensitive Optical Coherence Domain Reflectometry System

Matthew J. Everett, Joseph G. Davis

U.S. Patent 6,385,358 B1

May 7, 2002

An insensitive fiber-optic optical coherence domain reflectometry (OCDR) system containing nonpolarization maintaining (non-PM) fiber in the sample arm and the reference arm without suffering from signal degradation caused by birefringence. The use of non-PM fiber significantly reduces the cost of the OCDR system and provides a disposable or multiplexed section of the sample arm. The dispersion in the reference arm and sample arm of the OCDR system is matched to achieve high-resolution imaging. This system is useful in medical applications or for nonmedical in situ probes. The disposable section of non-PM fiber in the sample arm can be conveniently replaced when contaminated by a sample or a patient.

Increasing Subterranean Mobilization of Organic Contaminants and Petroleum by Aqueous Thermal Oxidation

Ronald N. Leif, Kevin G. Knauss, Robin L. Newmark,

Roger D. Aines, Craig Eaker

U.S. Patent 6,387,278 B1

May 14, 2002

In situ hydrous pyrolysis-partial oxidation of organics at the site of the organics constrained in a subsurface reservoir produces surfactants that can form an oil-water emulsion, which can be effectively removed from an underground formation. The removal of the oil-water emulsions is particularly useful in several applications, for example, soil contaminant remediation and enhanced oil recovery operations. A portion of the constrained organics reacts in heated reservoir water with injected steam containing dissolved oxygen gas at ambient reservoir conditions to produce such surfactants.

Electromechanical Battery Design Suitable for Back-up Power Applications

Richard F. Post

U.S. Patent 6,396,186 B1

May 28, 2002

The windings that couple energy into and out of the rotor of an electromechanical battery are modified. The normal stator windings of the generator-motor have been replaced by two orthogonal sets of windings. Because of their orthogonality, the windings are decoupled from each other electrically, although each can receive or deliver power flows from the rotating field produced by the array of permanent magnets. Because of the orthogonal design of the stator windings and the high mechanical inertia of the flywheel rotor, the resulting power delivered to the computer system is completely insensitive to any and all electrical transients and variabilities from the main power source. This includes insensitivity to complete failure for a period determined only by the amount of stored kinetic energy in the electromechanical battery modules. Furthermore, there is no need for fast-acting, fractional-cycle switches, such as those used in conventional systems, which are difficult to implement.

Condenser for Ring-Field Deep Ultraviolet and Extreme Ultraviolet Lithography

Henry N. Chapman, Keith A. Nugent

U.S. Patent 6,398,374 B1

June 4, 2002

A condenser for use with a ring-field deep ultraviolet or extreme ultraviolet lithography system. A condenser includes a ripple-plate mirror that is illuminated by a collimated or converging beam at grazing incidence. The ripple plate comprises a flat or curved plate mirror into which is formed a series of channels along an axis of the mirror to produce a series of concave surfaces in an undulating pattern. Light incident along the channels of the mirror is reflected onto a series of cones. The distribution of slopes on the ripple plate leads to a distribution of angles of reflection of the incident beam. This distribution has the form of an arc, with the extremes of the arc given by the greatest slope in the ripple plate. An imaging mirror focuses this distribution to a ring-field arc at the mask plane.

Low Pressure Drop, Multi-Slit Vertical Impactor**Werner Bergman**

U.S. Patent 6,402,817 B1

June 11, 2002

Fluid flow is directed to a multiplicity of slit nozzles positioned so that the fluid flow is directed into a gap between the nozzles and to a number of receiving chambers and a number of exhaust chambers. The nozzles and chambers are selected so that the fluid flow will be separated into a first-particle-flow component with larger particles and a second-particle-flow component with the smaller particles.

Process for Electrically Interconnecting Electrodes**Paul G. Carey, Jesse B. Thompson, Nicolas J. Colella, Kenneth A. Williams**

U.S. Patent 6,402,881 B1

June 11, 2002

Electrical interconnects for solar cells or other electronic components using a silver-silicone paste or a lead-tin no-clean fluxless solder cream, whereby the high breakage of thin (less than 6-mil-thick) solar cells using conventional solder interconnect is eliminated. The interconnects of this invention use copper strips that are secured to the solar cells by a silver-silicon conductive paste that can be used at room temperature or by a lead-tin solder cream that eliminates undesired residue on the active surfaces of the solar cells. Electrical testing using the interconnects of this invention has shown that no degradation of the interconnects developed under high-current testing and that the interconnects provided a low contact resistance value.

Thiacrown Polymers for Removal of Mercury from Waste Streams**Theodore F. Baumann, John G. Reynolds, Glenn A. Fox**

U.S. Patent 6,402,960 B1

June 11, 2002

Thiacrown polymers immobilized to a polystyrene-divinylbenzene matrix react with mercury ions (Hg^{2+}) under a variety of conditions to efficiently and selectively remove Hg^{2+} from acidic aqueous solutions, even in the presence of a variety of other metal ions. The mercury can be recovered and the polymer regenerated. This mercury removal method has utility in the treatment of industrial wastewater, where a selective and cost-effective removal process is required.

System for Beaming Power from Earth to a High Altitude Platform**Herbert W. Friedman, Terry J. Porter**

U.S. Patent 6,407,535 B1

June 18, 2002

Power is transmitted to a high-altitude platform by an array of diode-pumped solid-state lasers, each operated at a single range of laser wavelength outside of infrared and without using adaptive optics. Each laser produces a beam with a desired arrival spot size. An aircraft avoidance system uses a radar system for automatic control of the shutters of the laser.

Ultra-Precision Positioning Assembly**Richard C. Montesanti, Stanley F. Locke, Samuel L. Thompson**

U.S. Patent 6,408,526 B1

June 25, 2002

An apparatus and method for ultraprecision positioning. A slide base provides a foundation to support the apparatus. A slide plate moves with respect to the slide base along a first geometric axis. Either a ball screw or a piezoelectric actuator working separately or in conjunction displaces the slide plate with respect to the slide base along the first geometric axis. A linking device directs a primary force vector into a centerline of the ball screw. The linking device consists of a first link that directs a first portion of the primary force vector to an apex point located along the centerline of the ball screw and a second link for directing a second portion of the primary force vector to the apex point. A set of rails, oriented substantially parallel to the centerline of the ball screw, directs movement of the slide plate with respect to the slide base along the first geometric axis and is positioned such that the apex point falls within a geometric plane formed by the rails. The slide base, the slide plate, the ball screw, and the linking device together form a slide assembly. Multiple slide assemblies can be distributed about a platform. In such a configuration, the platform may be raised and lowered or tipped and tilted by jointly or independently displacing the slide plates.

Contour Forming of Metals by Laser Peening**Lloyd Hackel, Fritz Harris**

U.S. Patent 6,410,884 B1

June 25, 2002

A method and apparatus for forming shapes and contours in metal sections by generating laser-induced compressive stress on the surface of the metal work piece. The laser process can generate deep compressive stress to shape even thick components without inducing unwanted tensile stress at the metal surface. The precision of the laser-induced stress enables exact prediction and subsequent contouring of parts. A light beam of 10 to 100 joules per pulse is imaged to create an energy fluence of 60 to 200 joules per square centimeter on an absorptive layer applied over a metal surface. A tamping layer of water is flowed over the absorptive layer. The absorption of laser light causes a plasma to form and consequently creates a shock wave that induces a deep residual compressive stress into the metal. The metal responds to this residual stress by bending.

Awards

Brian Andresen, a senior staff scientist in the Chemistry and Materials Science Directorate, recently received two awards for the role he and other Laboratory researchers played in solving a southern California hospital murder case.

At the Glendale, California, Police Department's Appreciation and Awards luncheon, Andresen received a **Distinguished Service Award** sponsored by **Citizens for Law and Order**, a Glendale community group. He also received a second award from the **Glendale Police Department Homicide Task Force** in recognition of his "scientific expertise, dedication and commitment to a complex homicide investigation."

Both awards were for forensic science work done by Andresen and his Livermore colleagues in connection with the Efren Saldivar murder case. In January 2001, Saldivar, a respiratory therapist, was charged with using the muscle relaxer Pavulon to kill six older patients at Glendale Adventist Medical Center in 1996 and 1997.

Andresen, with the assistance of analytical chemist Armando Alcaraz, developed a way to identify Pavulon in bodies exhumed two to four years after the crime. Previously, no such techniques were available to detect Pavulon after such a long time.

In March 2002, Saldivar pleaded guilty to six murder counts and other charges in the case for which Andresen and his Livermore colleagues provided assistance to Glendale police.

In early June at the National Conference of the **American Nuclear Society**, Livermore chemist **Leonard Gray** received the 2002 **Seaborg Medal** for "outstanding accomplishment and meritorious achievement in actinide separations sciences."

The Seaborg Medal was established in 1987 by the University of California at Los Angeles Department of Chemistry and Biochemistry to honor individuals for their significant contributions to chemistry and biochemistry. It is named for the renowned chemist Glenn Seaborg, Nobel Laureate, former director of Lawrence Berkeley National Laboratory, and former chairman of the Atomic Energy Commission.

Gray's accomplishments include developing processes for the recovery and purification of plutonium from fuels and reactor targets classified as "nonprocessable" by the Department of Energy; developing chemical processes for the recovery and purification of plutonium from "hard-to-recover" plutonium scrap and residues; and recruiting and leading the international team of scientists and engineers who developed the ceramic immobilization form for the disposition of excess weapons plutonium. These and other accomplishments have decreased nuclear waste or provided it with a disposal pathway while adding large amounts of recovered or purified plutonium and other nuclear materials to the nation's stockpile.

A Hitchhiker's Guide to Early Earth

High-pressure experiments with one of Livermore's 6.2-meter-long light-gas guns are exploring the theory that amino acids and other building blocks of life may have arrived on Earth by hitchhiking on icy comets. Some modeling has been done in the past, but these are some of the first experiments to test the theory. Mixtures of amino acids and water are placed in a small capsule prior to the experiment, and in the few dozen high-pressure gas-gun experiments to date, 40 to 95 percent of the initial amino acids survived shock compression. More importantly, the dominant reaction products are various peptide pairings of the initial amino acids. Identical experiments using chemical weapon simulants have also begun to reveal what might happen to a missile-borne chemical weapon if it were intercepted by another missile en route to its target. These two disparate subjects are connected at a fundamental level by concern about the fate of organic liquids subjected to strong shock compression.

Contact:

Jennifer Blank (925) 423-8566 (blank4@llnl.gov).

A New World of Maps

The relatively new field of geographic information systems (GIS) marries the power of computers with the ever-increasing amount of information that is geospatially based. GIS tools organize, relate, analyze, and visualize data to help discover new meanings and insights. GIS maps are composed of layers of geographically superimposed data that allow analysts to handle and visualize large amounts of information simultaneously. GIS is helping a growing number of Livermore researchers to understand and communicate their research data. GIS is particularly effective when paired with computer modeling. Livermore projects using GIS include international and homeland security, the Department of Energy's National Atmospheric Release Advisory Center, prescribed burns and wildfire modeling, ecologic monitoring, and seismic studies.

Contact:

Charles H. Hall (925) 422-0922 (hall5@llnl.gov).

This Year's R&D 100 Awards



Livermore won five awards in *R&D Magazine's* annual competition for the 100 most significant technological products and processes. The winners:

- *In Situ Rolling Circle Amplification is so sensitive it can detect cancer and other diseases in the DNA of a single human cell.*
- *Thin-Film Coating Tool makes it possible to produce next-generation chips on a commercial scale with extreme ultraviolet lithography.*
- *The Transcutaneous Electrical Nerve Stimulation device is portable, inexpensive, and easy to use for pain management.*
- *The Microchannel-Cooled Laser Diode Array is the smallest, most powerful, and least expensive laser pumping source.*
- *The Solid-State Heat Capacity Laser is the most powerful solid-state laser in the world.*

Also in October in June

- *50th Anniversary Highlight—The Laboratory's nuclear weapons work has spawned research in energy and environment, which in turn fosters new capabilities to address other national needs.*

University of California
Science & Technology Review
Lawrence Livermore National Laboratory
P.O. Box 808, L-664
Livermore, California 94551

Nonprofit Org.
U. S. Postage
PAID
Albuquerque, NM
Permit No. 853



Printed on recycled paper.