

GEOHERMAL HOT DRY ROCK

1.0 System Description

The Hot Dry Rock (HDR) concept uses heat recovered from subsurface rocks to generate electricity. The system proposed for extracting heat from the rock and converting it to electricity is comprised of two distinct subsystems (see Figure 1) at very different stages of their technological evolution. The two subsystems are the power plant (on the surface) and the HDR reservoir (deep beneath the surface), which are connected by deep wells. The wells and reservoir are thought of as a single system, often referred to as the well field system or reservoir system. The power plant system is largely identical to commercial binary hydrothermal electric plants. The technology for the reservoir

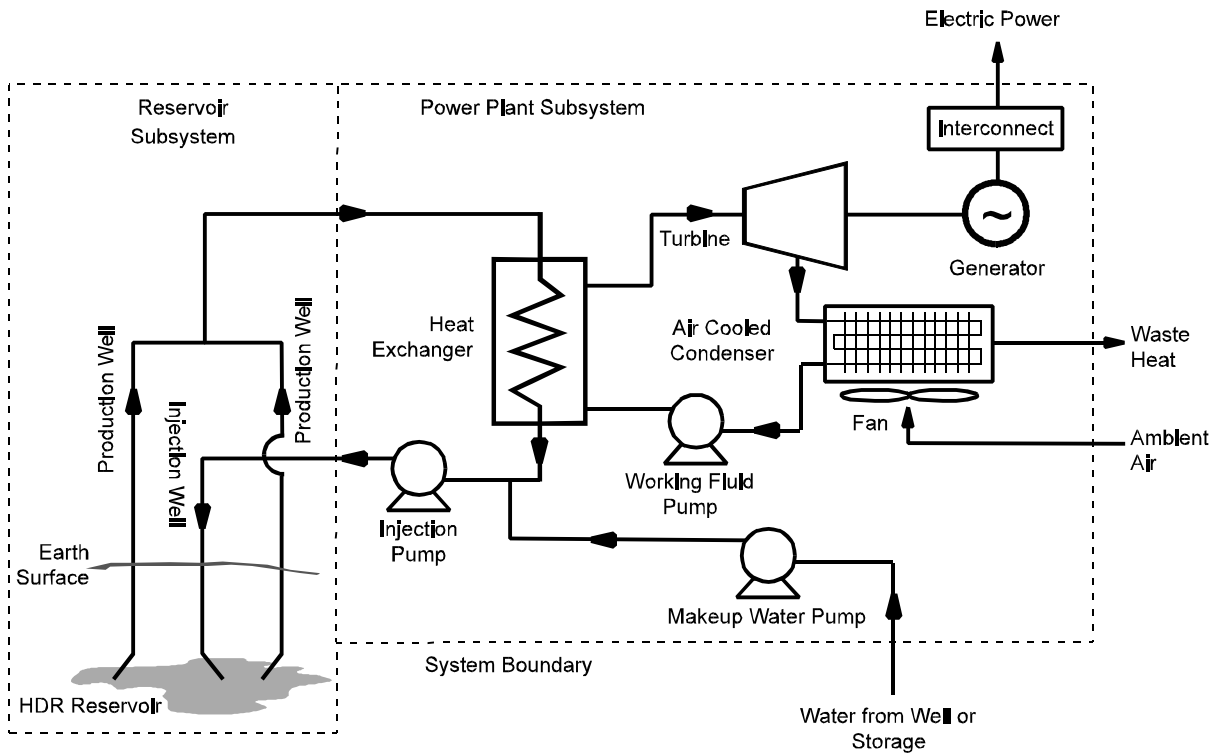

Figure 1. Hot dry rock electric power generation schematic.

system is much less mature. HDR reservoir creation and use has been demonstrated at experimental sites in the U.S., Europe, and Japan, but not on a commercial scale.

The reservoir subsystem is developed by drilling wells into hot rock about 4 kilometers deep, and connecting the wells through hydraulic fracturing. Water, from a nearby fresh water well or other source, is pumped through one or more injection wells into the reservoir, where it is heated by contact with the hot rock, and then recovered through two or more production wells.

At the surface, the power plant subsystem converts the extracted heat to electricity using commercial binary power plant technology. First, the produced hot water passes through a heat exchanger, transferring heat to a working fluid in the power plant. The working fluid is characterized by a low boiling temperature; hydrocarbons such as iso-pentane, iso-

GEOTHERMAL HOT DRY ROCK

butane, etc. are typically used. The vaporized working fluid is expanded across a turbine to drive a generator and produce electricity. The vaporized working fluid is then condensed in a cooling system and recirculated to the heat exchanger. The hot water, upon exiting the heat exchanger, is injected back into the reservoir to collect additional heat.

The major components of a HDR system are described briefly below:

1. One, or more, hot dry rock reservoirs, created artificially by hydraulically fracturing a deep well drilled into hot, impermeable, crystalline basement rock. The hydraulic fracturing, achieved by pumping water into the well at high pressure, forces open tiny pre-existing fractures in the rock, creating a system or "cloud" of fractures that extends for tens of meters around the well. The body of rock containing the fracture system is the reservoir of heat. The fracture system provides for the heat transport medium, water, to contact a large area of the rock surface in order to absorb the heat and bring it to the surface. More than one reservoir could supply hot water to a single power plant.
2. Deep wells for production and injection of water. The wells are drilled with conventional rotary drilling technology similar to that used for drilling deep oil and gas wells. The total number of wells and the ratio of production wells to injection wells may vary. Experimental HDR systems to date have typically involved one injection well and one production well. The earliest commercial HDR systems will likely include a "triplet," two production wells for each injection well. A triplet of deep wells will support about 5 MW of power plant capacity, assuming adequate flow rates and fluid temperature. It is possible that other well configurations, such as a quadruplet (3 production wells per injection well) or a quintuplet (4 production wells per injection well) could be used. However, the cost effectiveness of using a quadruplet or quintuplet has not been established. Also, the ellipsoidal, rather than spherical, shape of the fracture pattern at Fenton Hill suggests that one production well on each side of the injection well, on the long axis of the reservoir, is the logical configuration. For these reasons, this analysis is limited to a ratio of two production wells per injection well, with earlier commercial systems limited to three wells total, and later systems using multiple triplets of wells.

The original well, from which the fracture system is created, is used for injection. Two additional nearby wells are drilled directionally to intersect the fracture system and are used as production wells. Operation of the system involves pumping water into the fracture system through the injection well, forcing it through the fracture system where it becomes heated, and recovering it through the production wells.

3. A system of microseismic instruments in shallow holes around the well that is being fractured. During the fracturing operation, this system gathers seismic data, which is used to determine the extent and the orientation of the hydraulically created fracture system. This information is then used to guide the drilling of the production wells so that they intersect the fracture system at depth. Although the HDR system, once it is completed, can operate without it, the microseismic system is included here because it is an integral part of creating the HDR reservoir and because it may be left in place to gather additional information which could be useful later in the life of the HDR system. Note that the microseismic instruments are not depicted in Figure 1.
4. A shallow water well to provide water (or other source of fresh water).
5. Surface piping, or "gathering system," to transport water between the wells and power plant.

GEOTHERMAL HOT DRY ROCK

6. A binary power system to convert the heat in the water to electricity. This system is comprised of the following major components:
 - a. One or more turbines connected to one or more electric generators.
 - b. A heat exchange vessel to transfer heat from the hot water to a secondary working fluid with a low boiling temperature.
 - c. A heat rejection system to transfer waste heat to the atmosphere and condense the vapor exiting the turbine. A wet, or dry, cooling system can be used. The capital cost of a wet cooling system is only marginally less expensive than for a dry cooling system. However, this cost advantage is largely offset by the higher operating cost of the wet cooling system. For this reason, and since HDR sites in the U.S. are likely to be in arid areas with limited water supplies, this technology characterization is limited to a dry cooling system.
 - d. Injection pump(s) to circulate the water through the HDR reservoir.
 - e. Pumps to repressure the working fluid after it condenses and a vessel (not shown in Figure 1) for storing the working fluid.
 - f. Electrical controls and power conditioning equipment.

Additional information on binary systems can be found in the geothermal hydrothermal technology characterization and in Reference [1].

2.0 System Application, Benefits, and Impacts

HDR systems generate baseload electricity, but might also be used in load-following modes. An experiment conducted at Fenton Hill, New Mexico, in 1995 demonstrated that an HDR reservoir is capable of a significant, rapid increase in thermal power output on demand. In other words, an HDR electric plant could continuously generate power 24 hours a day and supply additional peak load power for a few hours each day. Los Alamos National Laboratory estimates that the thermal output could be increased by 65% for four hours each day without requiring additional wells or a larger reservoir [2]. Additional capital expense would be incurred to size the power plant and reinjection pumps to handle the increased output. However, it is possible that a price premium for the peaking power would exceed the additional costs, improving the economics of the system. An analysis of this mode of operation is not included in this study.

The Hot Dry Rock resource is important in that it is an untapped class of resource that could one day provide the nation with a significant amount of clean, reliable, economic energy. Its potential lies in its broad geographical distribution and its size. Hot dry rock is believed to exist in all geographic locations, but at different depths, depending on local geology. In the U.S., the higher grade (shallower) HDR resources exist in the western states, including Hawaii. A 1990 study conducted by the Massachusetts Institute of Technology [3] concluded the nation's high grade (gradient $> 70^{\circ}\text{C}/\text{km}$) HDR resources could potentially produce 2,875 GW at an average price below 10 ¢/kWh using current technology. This is over 400 times the world's current installed geothermal electric capacity.

The HDR resource is much larger and more widespread than hydrothermal resources and is probably, therefore, the future of geothermal energy in this country. The natural progression of hydrothermal development has been to utilize the higher quality resources first. As the higher quality sites are expended and the technology matures, a minimum cost will be achieved, and the cost of developing new hydrothermal resource sites will begin increasing. The minimum cost for HDR will likely occur later than that for hydrothermal (see Figure 2), and at some point the curves will probably intersect, meaning it will become less expensive to develop HDR resources than the remaining low quality hydrothermal resources. The shape of the curves or their relationship to each other in Figure 2 are not exact. They are

GEOTHERMAL HOT DRY ROCK

merely intended to illustrate the possibility that HDR will one day be less expensive than hydrothermal and that the historical minimum cost for hydrothermal binary will probably be less than, and occur before that, for HDR binary. It is the authors' estimate that the historical minimum cost for HDR will be approximately twice that for hydrothermal and will occur 15 to 20 years later.

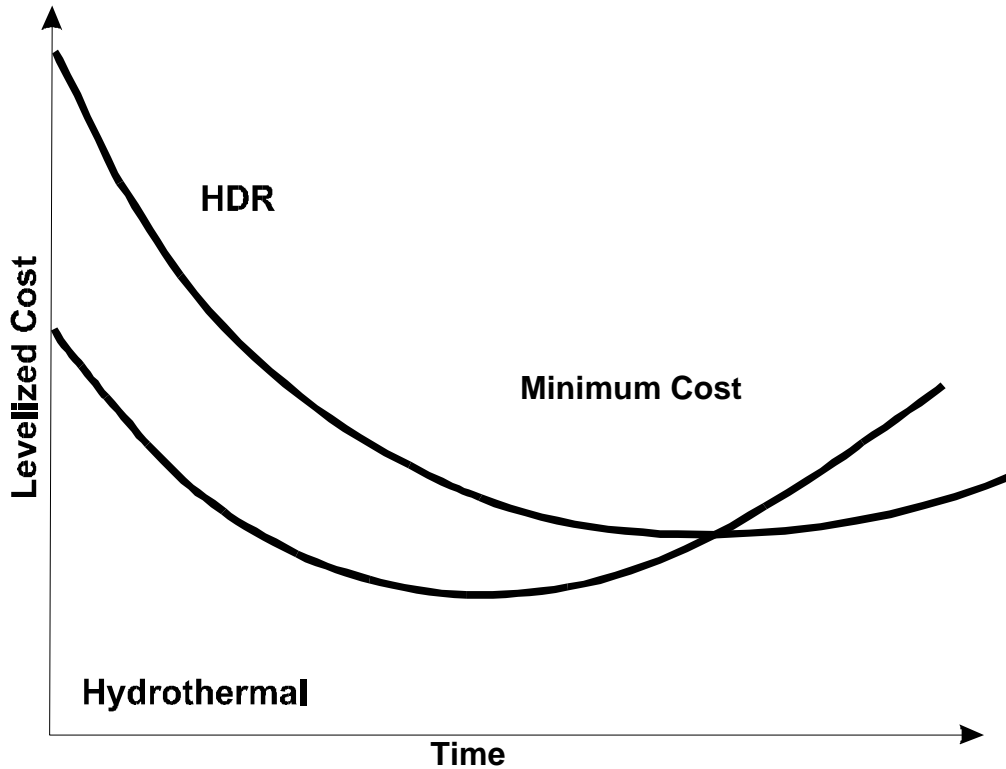

Figure 2. Hypothetical minimum cost curves for hydrothermal and HDR resources.

The environmental impacts of generating electricity from geothermal resources are benign relative to conventional power generation options. Geothermal power generation does not produce the federally regulated air contaminants commonly associated with other power generation such as sulfur dioxide, particulates, carbon monoxide, hydrocarbons, and photochemical oxidants. Some, but not all, hydrothermal fluids contain hydrogen sulfide and/or high levels of dissolved solids, such as sodium chloride. Thus, with geothermal hydrothermal power generation, the biggest environmental concerns are the possible emissions of hydrogen sulfide and contamination of fresh water supplies with geothermal brines. Hydrogen sulfide emissions are abated, when necessary, with environmental control technology, and ground water contamination is avoided through protective well completion practices. Generally, there is less possibility of adverse environmental impacts with hydrothermal binary generation than with hydrothermal flash generation because the hotter fluids used in flash plants tend to have greater concentrations of chemical contaminants than do less hot fluids typically used in binary plants. Also, in binary plants that employ dry, rather than wet, cooling systems, the geothermal fluid remains in a closed system and is never exposed to the atmosphere before it is injected back into the reservoir. See the characterization of geothermal hydrothermal technology elsewhere in this document for additional information.

GEOHERMAL HOT DRY ROCK

The possible environmental impacts from a HDR binary electrical generating system are likely to be considerably less than those from a hydrothermal system employing binary technology. The water used in the HDR system is from a shallow ground water well or other source of water with low levels of dissolved solids and no hydrogen sulfide. All the water in a system with dry cooling remains in a closed loop and is never exposed to the atmosphere, limiting emissions to possible minor leaks of the working fluid around valves and pipe joints. If a wet cooling system is used, there will be some evaporation into the atmosphere with possible minor emissions, the level of which will depend on the original water quality and any chemical changes the water may experience in the reservoir. However, such emissions would be quite small compared to emissions from even the best fossil fuel electric generating technologies.

Although some water loss in the reservoir is expected with HDR systems, ground water contamination is not a concern for two reasons. First, it is probable that fresh water will be used in the system. Second, the depth and relative impermeability of the reservoir will lower the probability that the water used would migrate to shallow fresh water reservoirs.

Water consumption is a concern with HDR plants since they will likely be located in arid areas of the western U.S. Leakage around the boundaries of the reservoir may be anywhere from 5% to about 15% of the injection flow rate [4]. This would constitute water consumption of about 2 to 6 m³/MWh in a mature 30 MW system. Larger losses are possible depending on the original permeability of the reservoir rock. Larger losses could render a project uneconomic depending on the availability and cost of water.

Siting HDR plants is complicated by the need for the plant to be located at the site of the resource. This may impact the use of other resources (cultural, agricultural, mining, etc.) at the same location. It would not be unusual for HDR resources to be co-located with mining or agricultural resources.

Land use for an HDR binary plant is expected to be minimal - ranging from about 6.1 ha (15 acres) for a 5 MW plant up to 10 ha (25 acres) for a 25 MW plant. Land disruption, erosion and sedimentation, and increased levels of noise and human activity may adversely impact biological systems in the immediate vicinity of the plant and wells.

Adverse visual impacts are also possible with HDR developments and would be of concern in inhabited areas and scenic areas. However, binary geothermal power plants are compact and have a very low profile compared to other industrial facilities. A combination of the low profile, landscaping, and color camouflage was used to successfully mitigate visual impacts at the 30 MW Mammoth Lakes binary power plant in California. It is located within about three miles of one of California's major ski resorts in a county that depends heavily on tourism.

3.0 Technology Assumptions and Issues

Commercially proven binary power plant technology is available for HDR application. However, critical issues remain regarding the cost and performance of the HDR reservoir. HDR reservoir creation has been successfully demonstrated, but operational experience with HDR reservoirs is insufficient to have resolved critical reservoir uncertainties regarding thermal drawdown, impedance, and water loss. High impedance to flow within experimental HDR reservoirs has resulted in much lower well production rates than in successful hydrothermal wells, as well as high parasitic power requirements for injection pumping. With less production from each well, a greater number of wells are required to supply the plant, and each well may cost 4 to 7 times that for a hydrothermal binary project because of the greater depth. Technological advances will be required to overcome this high cost of supplying hot water to the plant for HDR to become a commercially viable energy option.

GEOTHERMAL HOT DRY ROCK

The evolution of the HDR technology is described in this document by defining three separate stages, or vintages, of technology and estimating their timing based on assumptions about R&D funding levels, government energy policy (both in the U.S. and abroad), commercial experience, and energy markets. The three vintages, Current Technology, Second Generation Technology, and Mature Technology are defined briefly below and discussed further in Section 4.1.

The Current Technology vintage is based on the best, currently available, commercial drilling and power plant technologies, and experience at Fenton Hill, New Mexico, where the technical feasibility of HDR power generation was demonstrated by Los Alamos National Laboratory and DOE in the late 1970s. It is based on a single triplet of wells (one injection and two production wells). The power plant performance and cost are based on the Next Generation Geothermal Power Plant (NGGPP) study [5] published by the Electric Power Research Institute in 1996. Drilling costs are based on actual deep geothermal wells drilled recently in the western U.S. Reservoir operational parameters, thermal drawdown, and flow impedance were estimated by HDR scientists at Los Alamos National Laboratory [6]. The first commercial application of HDR systems will probably occur in about 6 to 20 years based on current technology and research levels, depending on governmental policies and market conditions. Experience from several years of operation at several commercial sites will be necessary to achieve Second Generation Technology.

The Second Generation Technology includes about 40% of the total improvement required to go from Current to Mature Technology. It will depend on technology improvements gained through both R&D and experience with the first few commercial HDR projects. The Second Generation Technology will probably be achieved no earlier than about 2015. Beginning in 2020, confidence in Second Generation Technology and lower costs will lead to slightly larger plants with two triplets of wells.

The Mature Technology is that for which further improvements will have only minor effect on the cost of power. It will depend on further improvements in power plant and deep well technologies, as well as additional experience gained at 15 to 20 commercial HDR operations. It will incorporate larger plants supplied by 4 or more triplets of wells. Mature Technology will probably not be achieved before about 2030.

Achieving these levels of technology in this time frame assumes that improvements will result from both R&D efforts and experience with commercial HDR plants as they are developed and operated. The progress of the technology will depend on complex interactions involving the levels of funding for drilling R&D, as well as more HDR-specific R&D in several countries, supply and demand in electricity markets, supply and demand in petroleum markets (which greatly influence drilling costs and funding of drilling research), public policy (especially regarding energy and the environment), and progress in other electric supply technologies.

Assumptions concerning related research include:

- HDR research efforts in Japan and Europe will continue.
- A significant HDR research program will be renewed in the U.S. at a funding level of \$7 to \$10 million annually by the year 2000.
- The U.S. will heavily fund R&D in deep drilling and well completion, resulting in a significant reduction in the cost of deep wells over the next 30 years.

Electricity demand is assumed to grow faster than supply, creating a positive atmosphere for further development of HDR technology. Petroleum markets are assumed to encourage private industry and government agencies to support significant levels of research in well drilling and completion and that the relationship between supply and demand for drilling services does not increase drilling costs significantly.

GEOTHERMAL HOT DRY ROCK

Energy policy assumptions are that the U.S. and other governments will encourage the earliest commercial development of HDR through various incentives similar to those used to encourage the development of hydrothermal power generation in the U.S.

As with hydrothermal power generation, HDR performance and economics depend heavily on the physical characteristics of the reservoir. This characterization assumes physical reservoir parameters believed characteristic of fairly high grade HDR resources in the Basin and Range geologic province (see Figure 3). This area is representative of a large portion of the higher grade domestic HDR resource, as measured by geothermal gradient (the increase in temperature with each unit increase of depth). Although the global average gradient is about 25°C/km, some areas have much higher gradients [3]. A higher gradient translates into improved HDR economics because the wells can be shallower. For this reason, the first few commercial HDR projects will likely be located where gradients are 80°C/km or better. A gradient of 65°C/km is assumed for this analysis in order to represent a larger portion of the HDR resource. This results in an average formation temperature of 275°C (527°F) at a depth of 4,000 meters.

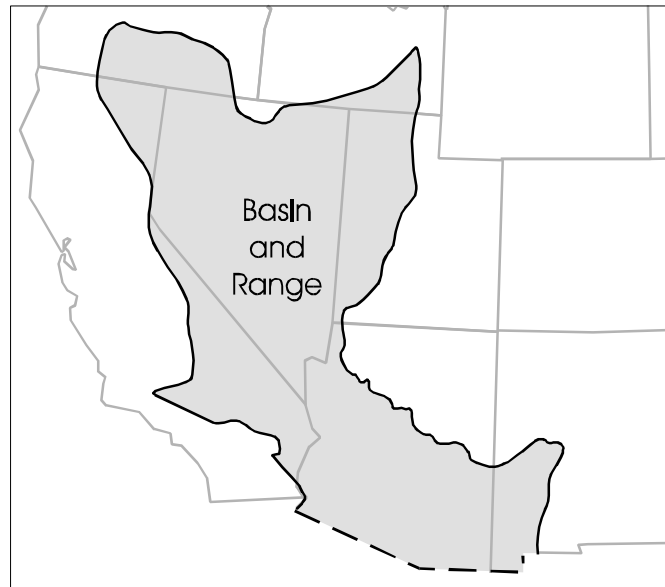

Figure 3. Basin and Range geologic province.

4.0 Performance and Cost

Table 1 summarizes the performance and cost indicators for the geothermal hot dry rock system being characterized in this report. These indicators, although finalized in this report, have evolved over several Technology Characterization exercises, beginning at Sandia National Laboratory in 1993 [7].

Table 1. Performance and cost indicators.

INDICATOR NAME	UNITS	Base Case		2000		2005		2010		2020		2030	
		1997	+/-%		+/-%		+/-%		+/-%		+/-%		+/-%
Plant Size	MW	6		6.40		6.51		6.75		17.91		35.81	
Injection Pump Parasitic	MW	1.20		1.20		1.20		1.20		3.12		6.24	
Net Plant Size	MW	5.06		5.20		5.31		5.55		14.78		29.57	
Performance													
Geothermal Gradient	°C/km	65		65		65		65		65		65	
Well Depth	km	4		4		4		4		4		4	
Reservoir Volume	10 ⁶ m ³	99		99		99		99		198		396	
Number of Well Triplets		1		1		1		1		2		4	
Triplet Flow Rate	1000 kg/hr	223.6	+0/-20	223.6	+0/-20	223.6	+0/-20	223.6	+0/-20	290.7	+0/-38	290.7	+0/-38
Net Brine Effectiveness	Wh/kg	28		28.6		29.12		30.12		30.8		30.8	
Capacity Factor	%	80		81		82		83		85		90	
Annual Energy Production	10 ³ MWh	35.45		36.85		38.14		40.36		110.06		233.07	
Capital Cost													
Exploration	\$/kW	395	10	385	10	377	+12/-10	360	+12/-8	135	+15/-6	68	+20/-6
Siting and Licensing		64		64		64		64		64		64	
Land (@ \$4,942/hectare)		5.93		5.78		5.65		5.40		2.71		1.69	
Field Costs													
Wells		2,076	+10/-10	1,878	+15/-8	1,631	+20/-5	1,384	+25/-0	945	+30/-0	639	+40/-0
Fracturing		611	+10/-5	595	+10/-5	553	+10/-5	501	+12/-3	406	+15/-0	391	+20/-0
Gathering System		99		91		81		71		58		55	
Fresh Water System		172		161		146		132		110		85	
Injection Pumps		140		137		134		128		115		115	
Total Field Cost		3,098		2,861		2,545		2,216		1,634		1,286	
Plant Cost		1,847	5	1,751	+7/-5	1,656	+10/-5	1,558	+15/-5	1,330	+20/-5	1,163	+30/-5
Project Cost		109		109		109		109		109		109	
Total Capital Requirement	\$/kW	5,519	+23/-6	5,176	+25/-6	4,756	+29/-5	4,312	+34/-4	3,276	+47/-3	2,692	+51/-3

Notes:

1. The columns for +/-% refer to the uncertainty associated with a given estimate.
2. Construction period is 2 years, with 35% of capital cost incurred in year 1 and 65% incurred in year 2.
3. Totals may be slightly off due to rounding.
4. Although, no commercial HDR systems have been built as of 1997, the base case cost (1996) is an estimate of what a commercial HDR system would have cost in 1996 based on commercial binary plants at hydrothermal sites and actual deep geothermal wells recently drilled in Nevada.

Table 1. Performance and cost indicators.(cont.)

INDICATOR NAME	UNITS	Base Case 1997		2000		2005		2010		2020		2030	
			+/-%		+/-%		+/-%		+/-%		+/-%		+/-%
Plant Size	MW	6		6.40		6.51		6.75		17.91		35.81	
Operation and Maintenance Cost													
Power Plant O&M	\$/kW/yr	50		45		37		33		30		30	
Daily Field O&M	\$/kW/yr	35		34		33		32		30		28	
Well Repair	\$/kW/yr	134		128		121		114		103		94	
Total Operating Costs	\$/kW/yr	219		207		191		179		163		152	

Notes:

1. The columns for +/-% refer to the uncertainty associated with a given estimate.
2. Totals may be slightly off due to rounding.
3. Although, no commercial HDR systems have been built as of 1997, the base case cost (1996) is an estimate of what a commercial HDR system would have cost in 1996 based on commercial binary plants at hydrothermal sites and actual deep geothermal wells recently drilled in Nevada.

GEOHERMAL HOT DRY ROCK

4.1 Evolution Overview

The evolution of the three HDR technology vintages is discussed below. The evolution of the technology between these stages and the uncertainty involved is evident in Table 1 and accompanying discussion in Section 4.2.

Current Technology: The Current Technology system is defined as the reservoir and power plant system that could have been built in the period 1996-1997. This relies heavily on the experience which the U.S. Department of Energy gained creating and testing the Phase I & II HDR reservoirs at Fenton Hill, NM. However, it is based on a triplet well configuration (two production wells and one injection well), compared to the doublet (one production well and one injection well) configuration at Fenton Hill. It also assumes that the HDR reservoir could be expanded to about six times the size of the current Fenton Hill reservoir and the heat could be swept from the reservoir by a single well triplet.

Second Generation Technology: The Second Generation Technology is similar to Current Technology in that it is a small plant utilizing a single triplet of wells. It assumes: (a) improvements of conversion (power plant) technology (which are expected to arise from R&D and demonstrations outside of the HDR Research Program), (b) that the HDR wells and fractures can be made considerably less expensive than currently, (c) that the reservoir volume can be expanded to about 1.3 times that assumed in the Base Case, and (d) that improved techniques for creating the reservoir result in a triplet flow rate 1.3 times that of the base case. It is estimated that the earliest such systems could be commercially available would be about 2015. This estimate is based largely on the assumption that the European HDR research program will be successful in its plan to complete a Scientific Pilot Plant by the year 2000 and an Industrial Prototype plant by the year 2002 [8]. After Second Generation Technology becomes available in 2015, it will be applied with multiple well triplets in the year 2020.

Mature Technology: This system is defined as that for which further improvements would have only insignificant impacts on the cost of power. It consists of a larger plant with 4 triplets of wells. It assumes: (a) improvements in well drilling and completion technology radical enough to reduce the cost of the HDR wells to 50 percent of their cost in the Base Case, (b) some additional incremental modest improvements in other aspects of the technology, (c) experiential improvements gained from 15 to 20 years of operations at 15 to 20 commercial HDR plants, and (d) a cost reduction compared to the Current Technology due to economies of scale achieved with a larger plant and 4 well triplets. It is estimated that the earliest this system could be achieved would be in about 30 to 50 years.

4.2 Performance and Cost Discussion

The estimated performance and cost through the year 2030 are presented in Table 1, along with uncertainty estimates of some of the key parameters. The Current and Mature Technology scenarios are represented in the columns for 1997 and 2030. Second Generation Technology is projected for 2015, such that projections in the 2010 and 2020 columns bracket the Second Generation Technology.

The cost of developing HDR geothermal resources is greater than that for hydrothermal binary plants although the technology employed is essentially the same. This is due to several factors. First, the greater unit cost of the binary power plant for HDR resources is due to scale (hydrothermal binary plant costs are based on a 50 MW plant). Second, HDR wells are much deeper than typical hydrothermal wells, making them 3 to 5 times more expensive. Finally, the estimated flow rate per HDR well is only about a third of that of a good hydrothermal well, requiring more wells for a given level of power output.

GEOHERMAL HOT DRY ROCK

The performance and cost estimates are based on a number of technical assumptions. The analysis assumes commercial binary power plant technology with dry cooling, similar to that used at numerous hydrothermal sites in the U.S. and elsewhere. The injected water will be heated to the average formation temperature but will lose about 24°C (75°F) by conduction through the well as it travels to the surface. This results in an initial plant inlet temperature of 251°C (484°F) for the geothermal fluid. However, for design conservatism, the plant is designed for and operated at an inlet temperature of 226°C (439°F).

Based on this temperature, a flow rate of about 224,000 kg per hour is required to support a small power plant, and it is estimated that a reservoir of 98 million m³ will contain sufficient heat to operate the plant for 20, or more, years. These parameters were used at Kansas State University, in GEOCRACK, to simulate the thermodynamic response of the reservoir. GEOCRACK is a discrete element hot dry rock reservoir simulator that accounts for rock deformation, heat transfer, and fluid flow [6]. The results, presented in Figure 4, indicate the timing of the thermal

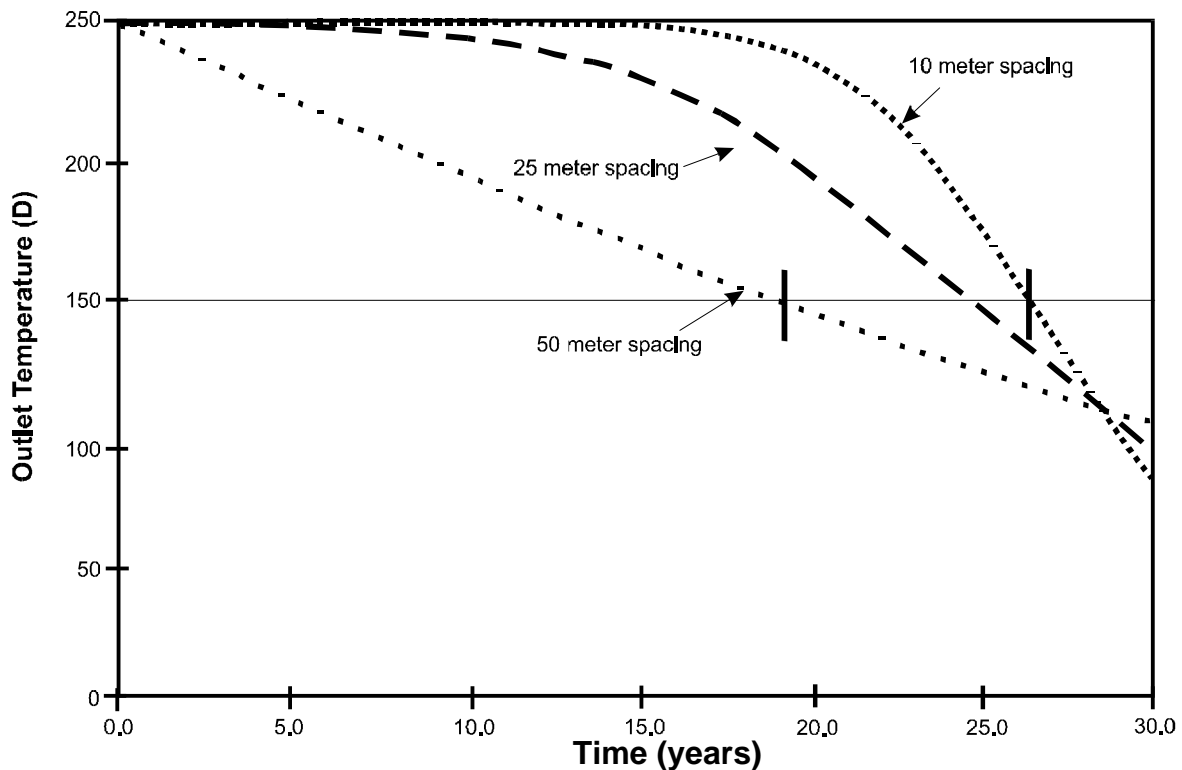

Figure 4. Results of GEOCRACK HDR reservoir simulation.

drawdown in the reservoir depends primarily on the distribution of the fracture joints through which the fluid flows. With narrow joint spacing (10 meters or less), the temperature will remain fairly flat for the first 18 to 20 years, and then drop fairly rapidly over the following 8 or 10 years. For this analysis, it is assumed the temperature will remain constant for the first twenty years and then drop by 200°C (392°F) over the following ten years.

Other key technical assumptions include:

GEOTHERMAL HOT DRY ROCK

- Thermal dilation of the reservoir fractures will contribute to achieving projected flow rates
- Reservoir injection pressure is 3,000 psi (20,684 kPa) and reservoir production pressure is 1,000 psi (6,895 kPa)
- Injection pump efficiency is 80% and pump motor efficiency is 95%.
- Well depth is 4,000 meters

Current Technology through Second Generation Technology employs a single triplet of wells. The technology in the year 2020 employs two triplets, and the Mature Technology employs 4 triplets.

The discussion below describes the basis for and calculations of the numbers in Table 1. The Second Generation and Mature technologies are referred to as the 2015 and 2030 technologies, respectively.

Net Brine Effectiveness (NBE) and Power Output: The net brine effectiveness is derived from Figure 5-2 of Reference [5]. For a plant inlet temperature of 226°C (439°F), the specific output is approximately 11.5 kW/1000 lb/hr brine. The parasitic power for injection and production pumps is about 9.8% of the net power [5]. Therefore, adjusting for injection and production pumping parasitic power yields:

$$\begin{aligned} \text{specific output} &= 11.5 / (1 - 0.098) = 12.75 \text{ kW/1,000 lb/hr brine:} \\ &= 28 \text{ Wh/kg brine} \end{aligned}$$

It is estimated by the authors that R&D can improve the NBE effectiveness in this temperature range by about 10%, and that this will be achieved incrementally by 2015.

System power output is the product of the net brine effectiveness, the number of well triplets, and the brine flow rate per well triplet. The net power output is the system output less the parasitic power required for injection. Power plant costs are based on the system power output.

Injection Parasitic Power: An injection pressure of 20,684 kPa (3,000 psi) and a production backpressure of 6,895 kPa (1,000 psi) is anticipated to maintain the desired pressure differential across the reservoir [6]. The plant outlet pressure is estimated to be 6,205 kPa (900 psi). To achieve the injection pressure, the injection pump must supply 20,684 - 6,205 = 14,479 kPa (2,100 psi). The required work rate to obtain a 223,600 kg/hr (1,000-gpm) flow rate, given a pump efficiency of 0.8 and a pump motor efficiency of 0.95, is given by

$$P_p = [(1,000 \text{ gal/min})^2(2,100 \text{ lb/in}^2)] / 1,714 / 0.8 / 0.95 = 1,612 \text{ hp} * 0.747 \text{ kW/hp} = 1,202 \text{ kW}$$

Capacity Factor: Although capacity factors for many hydrothermal binary plants are over 90% (see the characterization of geothermal hydrothermal technology elsewhere in this document), the capacity factor for the HDR Current Technology system is limited to 80% to reflect the fact that HDR wells will be too expensive to have any spare production or injection wells as is the practice with hydrothermal binary plants. Without spare wells and only one triplet, production will drop by 50% when one of the production wells is under repair, and by 100% when the injection well is under repair. The capacity factor is increased over time to reflect improved well completion technology and reduced time required for well repairs due to operational experience. Also, the capacity factor increases with increasing numbers of well triplets because a smaller proportion of the total flow will be suspended when a single well is shut in for maintenance.

Exploration Cost: Exploration costs for the Current Technology are estimated by the authors to be \$2 million based on their knowledge of hydrothermal exploration. Factors of 0.97, 0.94, and 0.90 are applied to the 1997 exploration cost for the 2005, 2010, and 2015 technologies, respectively. Factors of 0.85 and 0.80 are applied to the 1997 cost to reflect further technology cost reductions in 2020 and 2030, respectively. These estimated

GEOTHERMAL HOT DRY ROCK

cost reductions are based on the assumptions that both HDR R&D and HDR commercial experience will lead to improved exploration technology for HDR resources. A factor of 1.5 is applied to the 1997 cost to account for the economy of scale achieved in doubling the size of the field for the 2020 technology. A factor of 2.5 is applied to the 1997 cost to account for the economy of scale achieved in quadrupling the size of the field for the 2030 technology. These economy of scale factors are arbitrary estimates made by the authors.

Land Cost: Estimated at \$4,942/ ha (\$2,000/acre) and requirements of 6.1 ha (15 acres) for the plant and one well triplet, 8.1 ha (20 acres) for the plant and 2 well triplets (year 2020), and 10 ha (25 acres) for the plant and 4 well triplets (year 2030).

Well Cost: The 1997 costs of \$3.5 million per well are estimated by an experienced geothermal drilling engineer based on the costs of recently drilled deep (average depth of 3261 m, or 10,700 feet) geothermal wells in the Basin and Range [6]. The \$3.5 million includes all costs for drilling and completing a 4,000 m (13,124 ft) well. Well costs for the 2030 technology are estimated to be only 50% of those for the Current Technology. This is the authors' estimate of the greatest possible reduction in drilling costs that might be reasonably projected. It is premised on 4 propositions: (1) Sandia National Laboratory states that "Advanced technology development...has the potential for reducing geothermal drilling costs by at least 30% [9]; (2) New technology is capable of providing radical reductions in drilling cost as evidenced by Unocal's reference to its Thailand operations "Drillers learned to drill wells for 75% less the cost of wells in 1980" due to new technology [10]; (3) The Massachusetts Institute of Technology's National Advanced Drilling and Excavation Technology Institute has as its goal a 50% reduction in the cost of drilling [11]; and (4) In a 1994 study of future drilling technology, the National Research Council, an arm of the National Academy of Sciences, concluded "that revolutionary advances are within reach" and that "Rapid innovation in microelectronics and other fields of computer science and miniaturization technology holds the prospect for greater improvements - even revolutionary breakthroughs - in these (drilling) systems." [12]

For the 2015 well cost, a factor of 0.80 is applied to the 1997 cost of \$3.5 million per well to reflect cumulative incremental drilling and completion technology improvements. This results in a cost of \$2.8 million per well. For the 2030 cost, as stated above, a factor of 0.5 is applied to the 1997 cost of \$3.5 million per well to reflect further drilling and completion technology improvements. This results in a cost of \$1.75 million per well. Factors of 0.95 and 0.90 are applied to well costs in 2020 and 2030, respectively, to reflect economies of drilling multiple wells at the same location.

Fracturing Cost: The Current Technology fracturing costs are based on experience at Fenton Hill and are estimated to be \$3.09 million. The authors estimate that experience creating HDR reservoirs will result in improved techniques by 2015 that will intensify fracturing sufficiently to gain 30% more flow through the same size reservoir with a proportional increase in the cost. This increased cost is offset partially by technology improvements (expected from the combination of HDR R&D and experience with commercial HDR applications) accounted for by applying factors of 0.95, 0.90, and 0.85 to the 1997 costs to reflect costs in 2005, 2010, and 2015, respectively. Thus, the 2015 cost of fracturing is $0.85 \times 1.3 \times \$3.09$ million, or 545 \$/kW. Further technology improvements (expected from the combination of HDR R&D and experience with commercial HDR applications) will reduce the base cost by 17% and 20% in 2020 and 2030, respectively. Factors of 0.95 and 0.90 are applied to the fracturing costs in 2020 and 2030, respectively, to reflect economies of scale.

Fresh Water System Cost: The Current Technology cost is based on the cost of a fresh water well [4]. The cost remains unchanged through 2015. By 2030, it is reduced by 20% to reflect improved drilling technology. Factors of 0.95 and 0.90 are applied to the water system costs in 2020 and 2030, respectively, to reflect discounts for drilling multiple fresh water wells at the same location.

GEOTHERMAL HOT DRY ROCK

Injection Pumps Cost: Working from cost relationships adapted from Armstead and Tester [13], the installed cost of the injection pump and its electric motor drive is estimated to be \$710k. A factor of 1.2 is applied to this cost for 2015 to reflect the 30% increase in flow (the relationship between pump cost and flow rate is not linear). For 2030, a factor of 0.9 is applied to the 2015 cost to reflect improved technology. Factors of 0.97 and 0.95 are applied to the injection pump costs in 2020 and 2030, respectively, to reflect discounts for buying multiple pumps.

Power Plant Cost: The 1997 binary power plant cost is derived from cost data in Reference [5] for hydrothermal binary power plants. The plant cost is adjusted to account for the fact that downhole production pumps are not necessary with the HDR system. It is also adjusted to remove the embedded cost for injection pumps since the HDR system will require larger injection pumps (which are included in the field costs in the HDR TC).

The differences in the unit costs of the binary HDR plant and the binary hydrothermal plant (see geothermal hydrothermal technology characterization) are attributable to three factors. The cost adjustments mentioned in the previous paragraph and the higher inlet temperature for the HDR plant make it slightly less expensive than the hydrothermal binary. Also, it is assumed that there is an economy of scale inherent in the 50 MW binary hydrothermal plant cost in Reference [5]. A scaling factor of 0.9 is used to adjust the 50 MW cost to the appropriate size in each given year. For example, for the Current Technology:

$$6.26 \text{ MW unit cost} = 50 \text{ MW unit cost} * (6.26/50)^{0.9}/(6.26/50) = 50 \text{ MW unit cost} * 1.2309$$

The unit cost for the HDR binary plant is derived from Reference [5] cost data in the following manner:

Field Cost (from Table 6-3, Reference [5], Vale resource):

production wells	\$24,705,882
injection wells	\$10,500,000
gathering system	<u>\$ 1,333,187</u>
	\$36,539,069 or 731 \$/kW

Calculation of plant costs (1993 \$/kW):

Total Project Cost	2,125	Figure 5-4 of 2/96 NGGPP
Field Cost	-731	Table 6-3 of 2/96 NGGPP, Vale resource
Injection Pumps	- 3	cost estimate
Production Pumps	- 38	cost estimate
Electrical Interconnect	<u>+20</u>	cost estimate
	1,373	Power plant cost

Adjust to 1997 dollars:	1,500 \$/kW
Extract economy of scale:	1.2309*1,500 = 1,847 \$/kW

Binary power plant cost reductions due to technology improvements are estimated to total 25% over the entire period. This is allocated by applying the factors 0.95, 0.90, 0.85, 0.825, 0.80 and 0.75 in the years 2000, 2005, 2010, 2015, 2020, and 2030, respectively. This is based on reference [5], as well as the authors' combined 25 years of experience analyzing geothermal technology and R&D. The reader may refer to the characterization of hydrothermal geothermal for further discussion.

Total Capital Cost: The total project unit cost is the sum of the individual costs listed above plus a project cost of \$109/kW [5]. The project cost covers the owner's administrative costs and plant start-up costs.

GEOHERMAL HOT DRY ROCK

Operation and Maintenance Costs: HDR power plant O&M costs are estimated to be equal to those of a hydrothermal binary power plant. The reader is referred to the section on hydrothermal binary for a discussion of binary power plant O&M.

Well field O&M cost components are taken from Reference [4] and adjusted to 1997 dollars. Daily operation and maintenance will cost about \$218k/yr. This cost assumes one person's labor plus maintenance and repair contracts. Additionally, hydrothermal wells require work-over and clean-out every one to two years depending primarily on brine chemistry. It should be possible to maintain a certain amount of control over the chemistry in HDR wells, thus reducing the maintenance schedule when compared to hydrothermal wells. On this basis, it is assumed that each HDR well will need a work-over every three years; thus the site average will be one well per year.

Clean-out and work-over will require a work-over rig for about 15 days at \$11k/day (\$165k). Mobilization and demobilization of the rig will cost another \$109k. Materials for work-over (wellhead, cement, casing, etc.) are estimated to cost between \$164k and \$545k. Using a mid-range value of \$350 for materials yields an estimate of \$624k for work-over. Combining work-over and daily maintenance, well field O&M is estimated to cost \$842k/yr.

Uncertainty: Considerable uncertainty is inherent in projecting future costs and technology improvements. This uncertainty is estimated subjectively with plus/minus percentage figures for key parameters in Table 1. The projections are for the very best technology that it is believed could be reasonably achieved, and so the estimates for uncertainty are weighted heavily toward lower performance, less improvement and less reduction in cost. The most uncertain estimates are the flow rate per triplet of wells and the 50% reduction in the cost of deep wells. Therefore, the uncertainty estimates for the flow rate are based on 20% less flow for the Current Technology and failure to achieve the 30% increase in flow rate for the Second Generation Technology. Also, the uncertainty estimate for the well cost is based on achieving only a 30%, rather than 50%, reduction in the cost of wells. These two major uncertainties and other less significant uncertainties combine to result in the uncertainty for the total capital requirement. The uncertainty for the total capital requirement in the year 2030 is that it may cost 3% less than or 51% more than the projected \$2,977 per installed kW of capacity.

5.0 Land, Water, and Critical Materials Requirements

Land Requirement: As shown in Table 2, the land requirement is assumed to be similar to those for hydrothermal electric systems. It includes the land occupancy for the power plant and surface disturbances due to wells and pipelines. Roads to the site are not included. The unit land requirements decrease with larger plants.

Water Consumption: Water is required for drilling the deep HDR wells, and for fracturing the HDR reservoir rock. The amounts required are not quantified here. The system water "makeup" well would be drilled before the HDR deep wells are drilled; thus all water needed by the system except for that needed to drill the water well would come from that well.

The power plant is designed with dry cooling towers, so there is no major water consumption by the power plant per se. This is a conscious decision in the system design configuration based on the premise that HDR systems will most likely be developed at arid locations in the western U.S.

GEOTHERMAL HOT DRY ROCK

Table 2. Resource requirements.

Indicator Name	Units	Current Technology		
		1997	2020	2030
Net Plant Size	MW	5.06	14.78	29.57
Land Requirement	ha/MW	1.2	.55	.34
	ha	6.1	8.1	10.1
Water				
Injection Flow Rate	m ³ /MWh	44.87	40.82	39.93
Estimated Water Consumption	m ³ /MWh	2.24-6.73	2.04-6.12	2.0-5.99

Notes:

1. Water consumption is based on the rate of 5% to 15% of the injection rate.
2. The year 2000-2010 cases are not included in Table 2 because they are all single well triplet plants similar to the 1997 case

Almost all of the water consumption during system operation will be for water that enters and remains in the HDR reservoir. Water loss during initial system operation is estimated to be 5% to 15% of the volume pumped through the fracture system [4]. However, these estimates of water loss are based on limited testing of other than commercial-size systems and are uncertain. Actual losses could be more or less depending on the original permeability of the reservoir rock. It is estimated by a HDR scientist at Los Alamos National Laboratory that in a commercial system the water loss would become negligible with time [14], on the order of one to two percent of HDR reservoir circulation flow rate.

Energy, Feedstock, and Critical Materials: Electricity is required for startup from cold shutdown. The capacity required is some major fraction of the core-plant cycle parasitic power needs (e.g., for binary fluid circulation pumps and cooling fans) plus the power needed to run the HDR-loop high-pressure injection pumps.

Organic or other working fluid is needed to charge the binary power module, and replace small leakage losses during operation. There are essentially no special materials in these systems.

GEOTHERMAL HOT DRY ROCK

6.0 References

1. Elovic, A., "Advances in Binary Organic Rankine Cycle Technology," Geothermal Resources Council Transactions, p. 511, 1994.
2. Brown, D.W., "The Geothermal Analog of Pumped Storage for Electrical Demand Load Following." Proceedings of the 31st Intersociety Energy Conversion Engineering Conference, Vol. 3, August 1996.
3. Tester, J.W., and H. J. Herzog, Economic Predictions for Heat Mining: A Review and Analysis of Hot Dry Rock (HDR) Geothermal Energy Technology, Energy Laboratory, Massachusetts Institute of Technology, Cambridge, Massachusetts: July 1990. Report MIT-EL 90-001.
4. Pierce, K.G., and B.J. Livesay, "An Estimate of the Cost of Electricity Production from Hot-Dry Rock," Geothermal Resources Council Bulletin. Vol. 22, No. 8 (September 1993).
5. Brugman, J.M., M. Hattar, K. Nichols, and Y. Esaki, Next Generation Geothermal Power Plants, Electric Power Research Institute: February 1996. Report EPRI TR-106223.
6. Brown, D., and D. Duchane, Los Alamos National Laboratory, personal communication to Lynn McLarty on November 5, 1996.
7. The authors are indebted to an earlier, unpublished HDR technology characterization study conducted by Kenneth G. Pierce at Sandia National Laboratory, 1993.
8. Baumgartner, J., R. Baria, A. Gerard, and J. Garnish, "A Scientific Pilot Plant: The Next Phase of the Development of HDR Technology in Europe." Proceedings of the 3rd International HDR Forum, Santa Fe, New Mexico (May 13-16, 1996).
9. Glowka, D.A., "Geothermal Drilling Research Overview," Proceedings of the Geothermal Program Review XIV, April 1996, p. 217. U.S. Department of Energy report DOE/EE-0106.
10. Hulce, D.L., "Geothermal Energy - Business Challenge and Technology Response," Proceedings of the Geothermal Program Review XIV, p. 21 (April 1996). U.S. Department of Energy report DOE/EE-0106.
11. "National Advanced Drilling and Excavation Technologies Program and Institute," Proceedings of the Geothermal Program Review XIV, p. 243 (April 1996). U.S. Department of Energy, Report DOE/EE-0106. U.S. Department of Energy report DOE/EE-0106.
12. Drilling and Excavation Technologies for the Future, National Research Council, National Academy Press, Washington, D.C., 1994.
13. Armstead, H.C.H, and J. Tester, Heat Mining: A New Source of Energy, E. & F.N. Spon Ltd, University Press, London, 1987.
14. Duchane, D.V., Hot Dry Rock Heat Mining Geothermal Energy Development Program, Los Alamos National Laboratory: FY1991 Annual Report, January 1992. Report LA-UR-92-870.