

## Methods for Estimating Basin Yield and Recharge

Total yield, which is considered to be the sum of runoff plus recharge, was estimated over selected areas using the “yield-efficiency algorithm” discussed in a previous section. Estimates of precipitation, total yield, and evapotranspiration for the entire study area are presented in table 11. For 1950-98, precipitation averaged 18.98 inches or about 5.2 million acre-ft/yr. This is equivalent to an average flow rate of about 7,240 ft<sup>3</sup>/s. Of this amount, total yield is estimated as about 440,600 acre-ft/yr (about 608 ft<sup>3</sup>/s), which is equivalent to about 1.59 inches over the study area. Thus, evapotranspiration is estimated as 17.39 in/yr, which accounts for about 92 percent of annual precipitation.

Total yield was apportioned between precipitation recharge and runoff on the basis of recharge factors for each aquifer (table 12). With the exception of localized aquifers in the crystalline core, as discussed later, recharge was estimated by multiplying the total yield by the recharge factor, which is the fraction of total yield estimated to be recharge for a particular unit. The remainder of total yield (if any) was assumed to contribute to runoff from the outcrop area. Of the total average annual precipitation in the study area (table 11), runoff accounts for about 4.9 percent (352 ft<sup>3</sup>/s), and precipitation recharge accounts for about 3.5 percent (256 ft<sup>3</sup>/s). Thus, only a small fraction of the water originating from precipitation recharges the aquifers by infiltrating in outcrop areas.

**Table 11.** Estimates of average precipitation, precipitation recharge, runoff, total yield, and evapotranspiration for the study area, water years 1950-98

[Modified from Driscoll and Carter (2000)]

Units	Precipitation	Precipitation recharge	Runoff	Total yield (Precipitation recharge + runoff)	Evapotranspiration
Acre-feet per year	5,245,400	185,500	255,100	440,600	4,804,800
Cubic feet per second	7,240.4	256	352	608.2	6,632.2
Inches per year	18.98	0.67	0.92	1.59	17.39

**Table 12.** Recharge factors and outcrop areas for bedrock aquifers

[From Driscoll and Carter (2001). --, not applicable]

Aquifer unit	Recharge factor <sup>1</sup>	Outcrop area (acres)
Localized aquifers in crystalline core area (Precambrian/Tertiary/Other <sup>2</sup> )	--	616,800
Deadwood	0.80	66,200
Madison	1.00	292,600
Minnelusa	1.00	300,000
Minnekahta	1.00	72,100
Inyan Kara	.80	219,700
Jurassic-sequence semiconfining unit	.40	75,800
Cretaceous-sequence confining unit	.05	716,100

<sup>1</sup>Fraction of total yield estimated to result in recharge, with remainder (if any) assumed to contribute to runoff.

<sup>2</sup>Other consists of other units within the crystalline core area, including: (1) isolated outcrops of the Deadwood Formation, Madison Limestone, and Minnelusa Formation, and Minnekahta Limestone above the loss zones; and (2) unconsolidated sedimentary deposits.

As previously discussed, direct runoff from outcrops of the Madison Limestone and Minnelusa Formation seldom occurs. Thus, all precipitation on these outcrops that is not evapotranspired was assumed to recharge the aquifers; hence, recharge factors for these aquifers were assumed to be 1.00. The recharge factor for the Minnekahta aquifer also was assumed to be 1.00, based on similar formation properties between the Minnekahta Limestone and Madison Limestone. Recharge factors for the Inyan Kara and Deadwood aquifers were assumed to be 0.80 because these formations contain more shale layers than the Madison, Minnelusa, and Minnekahta Formations. The Sundance aquifer within the Jurassic-sequence semiconfining unit is a productive aquifer, but only constitutes about one-half of the outcrop area of the total unit. Thus, a recharge efficiency of 0.40 (one-half of 0.80) was assumed for the entire Jurassic-sequence semiconfining unit. Likewise, the Newcastle Sandstone contains a productive aquifer within the Cretaceous-sequence confining unit; however, the Newcastle Sandstone constitutes only a small portion of the total unit in outcrop area. Thus, a recharge factor of 0.05 was assumed for the entire Cretaceous-sequence confining unit.

Recharge does occur to numerous localized aquifers within the crystalline core area, especially where extensive fractures and weathered zones are present. These aquifers are not considered regional, however, as indicated by the fact that wells constructed in Precambrian rocks in western South Dakota outside of the Black Hills have not encountered measurable amounts of ground water (Rahn, 1985). Thus, regional ground-water flow in the Precambrian rocks was assumed to be negligible although some flow may occur in the upper weathered zone. Recharge to localized aquifers in the crystalline core area was assumed equal to well withdrawals from this unit. Actual recharge to the crystalline core aquifers must be much larger than this estimate to accommodate ground-water discharge that contributes to base flow of many streams. Recharge conditions are highly transient and have large spatial variability; thus, quantification was not attempted.

Within the crystalline core area, numerous erosional remnants of sedimentary outcrops occur that are "isolated" from regional ground-water flow systems as described in a previous section (fig. 14). Precipitation recharge was prescribed only for "connected" outcrops and was not prescribed for isolated outcrops. Infiltration of precipitation on isolated outcrops was assumed

to contribute to streamflow, which eventually has potential to provide streamflow recharge to the Madison and Minnelusa aquifers. Additional methods beyond identification of isolated and connected outcrop areas were used in quantifying precipitation recharge for the Deadwood aquifer as described by Driscoll and Carter (2001). Additional details regarding precipitation recharge are discussed in the following sections.

## Ground-Water Budgets

Ground-water budgets were developed for five major, sedimentary bedrock aquifers within the study area (Deadwood, Madison, Minnelusa, Minnekahta, and Inyan Kara aquifers) and for additional minor aquifers within the Jurassic-sequence semiconfining unit and Cretaceous-sequence confining unit. A budget also was developed for localized aquifers within the crystalline core area, which is dominated by Precambrian igneous and metamorphic rocks, but also includes Tertiary igneous rocks, erosional remnants of various sedimentary rocks, and minor, unconsolidated sedimentary deposits. These localized aquifers are subsequently referred to as the crystalline core aquifers. A combined budget was developed for the Madison and Minnelusa aquifers because most of the budget components cannot be quantified individually for these two aquifers; this budget is presented prior to budgets for the other bedrock aquifers.

Long-term budgets were developed for the period 1950-98, during which changes in ground-water storage were assumed to be negligible. Various components in equation 1 for ground-water budgets are schematically illustrated in figure 16 for the Madison aquifer. Inflows may include recharge, vertical leakage from adjacent aquifers, and lateral ground-water inflows across the study area boundary. Recharge occurs at or near land surface and includes infiltration of precipitation on outcrops of the bedrock units and streamflow recharge, which occurs where streams cross the outcrops. Streamflow recharge was considered an inflow component only for the Madison and Minnelusa aquifers. Although the Minnekahta aquifer also receives limited recharge from streamflow losses, this recharge probably is very small relative to streamflow recharge to the Madison and Minnelusa aquifers and could not be quantified.

Outflows include springflow, well withdrawals, vertical leakage to adjacent aquifers, and lateral

ground-water outflow across the study area boundary. Springflow includes headwater springs and artesian springs. Headwater springs, which generally occur near the base of the Madison Limestone in the Limestone Plateau area, were considered an outflow component for only the Deadwood, Madison, and Minnelusa aquifers. Artesian springs, which constitute a form of leakage but are treated as a separate component because of magnitude and measurability, were considered an outflow component for only the Madison and Minnelusa aquifers.

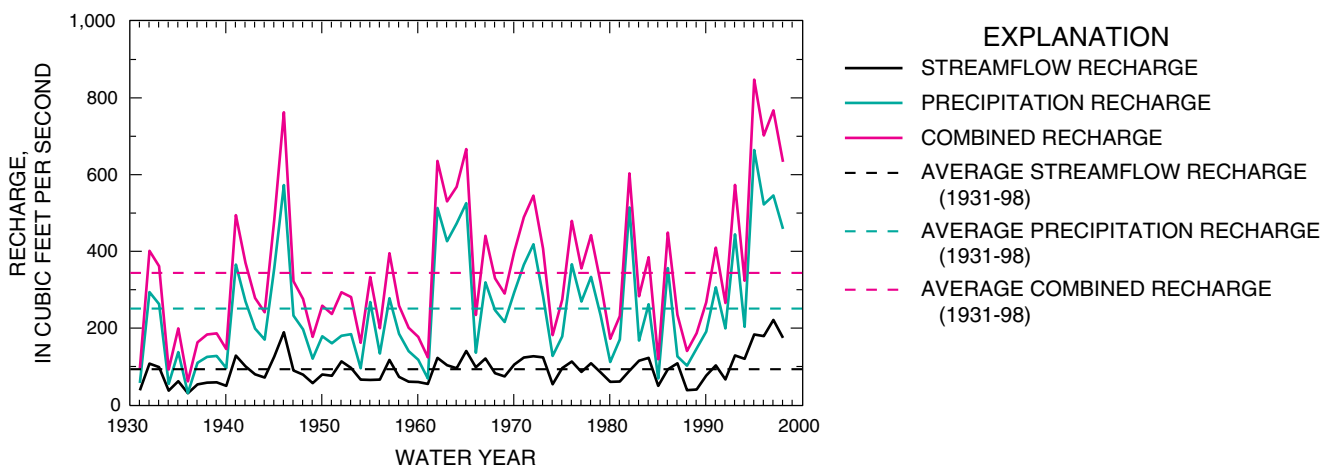
Vertical leakage to and from adjacent aquifers, which is difficult to quantify and cannot be distinguished from lateral ground-water inflows or outflows across the study area boundaries, probably is small relative to other budget components in most cases. Thus, for budget purposes, leakage was included with ground-water inflows and outflows. Assuming that  $\Delta Storage$  is equal to zero, the sum of the inflows is equal to the sum of the outflows, and the hydrologic budget equation can be rewritten as:

$$\begin{aligned} & \text{Ground-water}_{\text{outflow}} - \text{Ground-water}_{\text{inflow}} \\ & = \text{Recharge} - \text{Headwater springflow} \\ & - \text{Artesian springflow} - \text{Well withdrawals} \quad (3) \end{aligned}$$

The terms on the right side of equation 3 generally can be quantified more accurately than the terms on the left. Therefore, net ground-water flow (outflow minus inflow) from the study area can be calculated as the residual, given estimates for the other budget components.

### Budgets for Madison and Minnelusa Aquifers

Recent investigations have provided extensive information regarding various budget components for the Madison and Minnelusa aquifers, which are presented in table 13. Many of the budget components were based on hydrologic measurements with relatively short periods of record. Precipitation records indicate that prolonged drought conditions occurred prior to many available hydrologic records. Thus, Carter, Driscoll, and Hamade (2001) estimated recharge for the Madison and Minnelusa aquifer for 1931-98 (fig. 68) to address particularly dry conditions that occurred during the 1930's and 1950's. Estimates of streamflow recharge, precipitation recharge, and combined recharge from both sources (for the expanded area that includes part of Wyoming) are shown in figure 68. The 1931-98 averages are smaller than the 1950-98 averages (table 13) because of prolonged droughts during the 1930's and 1950's. Streamflow recharge is relatively steady; however, precipitation recharge is highly variable, depending on annual precipitation amounts.



**Figure 68.** Annual recharge to the Madison and Minnelusa aquifers, water years 1931-98, in the Black Hills of South Dakota and Wyoming (from Carter, Driscoll, and Hamade, 2001).

**Table 13.** Estimated annual hydrologic budget components for the Madison and Minnelusa aquifers, water years 1931-98, for the Black Hills of South Dakota and Wyoming

[All estimates in cubic feet per second. --, not determined]

Water year	Recharge <sup>1</sup>			Headwater springflow <sup>2</sup>	Artesian springflow <sup>3</sup>	Well withdrawals <sup>3</sup>	Net ground-water outflow <sup>3</sup>
	Streamflow	Precipitation	Total				
1931	38.17	57.37	95.53	3.6	--	--	--
1932	107.61	293.82	401.44	76.7	--	--	--
1933	98.50	262.78	361.28	63.6	--	--	--
1934	37.38	54.70	92.08	4.5	--	--	--
1935	61.71	137.54	199.25	28.6	--	--	--
1936	30.45	31.08	61.53	1.0	--	--	--
1937	53.55	109.75	163.30	16.4	--	--	--
1938	58.12	125.31	183.44	21.4	--	--	--
1939	58.78	127.53	186.31	24.0	--	--	--
1940	49.57	96.18	145.75	13.5	--	--	--
1941	128.70	365.63	494.34	99.7	--	--	--
1942	100.57	269.84	370.41	65.4	--	--	--
1943	79.75	198.96	278.72	48.5	--	--	--
1944	71.33	170.29	241.62	36.2	--	--	--
1945	125.98	356.35	482.33	102.1	--	--	--
1946	189.51	572.68	762.19	190.8	--	--	--
1947	89.69	232.79	322.47	56.5	--	--	--
1948	79.14	196.87	276.01	45.9	--	--	--
1949	56.72	120.53	177.24	20.1	--	--	--
1950	79.50	178.87	258.36	40.0	--	--	--
1951	76.09	160.75	236.84	30.5	--	--	--
1952	113.52	180.03	293.55	41.7	--	--	--
1953	96.62	184.32	280.94	45.8	--	--	--
1954	66.10	95.61	161.71	16.9	--	--	--
1955	65.04	268.06	333.09	71.0	--	--	--
1956	65.90	134.06	199.96	25.2	--	--	--
1957	117.12	278.05	395.17	70.7	--	--	--
1958	73.20	185.27	258.47	39.8	--	--	--
1959	60.53	140.36	200.89	26.2	--	--	--
1960	59.57	117.59	177.16	26.7	--	--	--
1961	54.97	68.88	123.85	7.0	--	--	--
1962	122.52	513.23	635.75	158.7	--	--	--
1963	103.64	426.54	530.18	128.5	--	--	--
1964	95.48	472.86	568.33	157.9	--	--	--
1965	140.80	525.80	666.60	161.7	--	--	--
1966	98.23	136.11	234.33	21.1	--	--	--
1967	121.00	319.45	440.45	83.3	--	--	--

**Table 13.** Estimated annual hydrologic budget components for the Madison and Minnelusa aquifers, water years 1931-98, for the Black Hills of South Dakota and Wyoming—Continued

[All estimates in cubic feet per second. --, not determined]

Water year	Recharge <sup>1</sup>			Headwater springflow <sup>2</sup>	Artesian springflow <sup>3</sup>	Well withdrawals <sup>3</sup>	Net ground-water outflow <sup>3</sup>
	Streamflow	Precipitation	Total				
1968	82.87	246.91	329.78	62.2	--	--	--
1969	74.24	215.90	290.14	50.6	--	--	--
1970	105.19	293.58	398.77	78.7	--	--	--
1971	123.68	365.41	489.09	101.4	--	--	--
1972	126.93	418.46	545.40	119.9	--	--	--
1973	123.78	283.41	407.18	69.5	--	--	--
1974	54.09	127.82	181.92	23.3	--	--	--
1975	96.06	178.43	274.49	37.5	--	--	--
1976	113.01	366.44	479.45	101.1	--	--	--
1977	86.23	269.50	355.73	69.1	--	--	--
1978	108.65	333.69	442.34	88.7	--	--	--
1979	84.96	233.26	318.22	54.8	--	--	--
1980	60.17	112.06	172.23	18.0	--	--	--
1981	60.88	170.50	231.38	32.4	--	--	--
1982	89.00	514.20	603.20	158.7	--	--	--
1983	115.39	167.59	282.97	37.7	--	--	--
1984	122.53	262.19	384.72	63.2	--	--	--
1985	49.88	68.91	118.79	8.0	--	--	--
1986	92.52	356.64	449.17	90.8	--	--	--
1987	108.41	126.33	234.73	21.1	199.6	28.3	100.4
1988	38.38	102.37	140.74	16.2	186.2	28.3	100.4
1989	40.36	146.66	187.01	26.6	163.4	28.3	100.4
1990	76.27	190.95	267.22	38.7	168.1	28.3	100.4
1991	103.11	306.66	409.77	74.9	170.6	28.3	100.4
1992	66.30	199.31	265.61	48.5	165.9	28.3	100.4
1993	128.83	444.35	573.18	127.2	173.9	28.3	100.4
1994	120.16	203.50	323.65	49.3	193.6	28.3	100.4
1995	183.57	663.81	847.38	214.6	221.5	28.3	100.4
1996	179.48	522.32	701.80	158.2	245.9	28.3	100.4
1997	221.55	545.83	767.38	192.9	--	--	--
1998	174.77	458.38	633.15	152.8	--	--	--
1931-98 average	93.18	250.90	344.08	65.5	--	--	--
1950-98 average	98.39	271.04	369.40	72.2	--	--	--
1987-96 average	104.49	290.63	395.11	77.5	188.9	28.3	100.4

<sup>1</sup>From Carter, Driscoll, and Hamade (2001).

<sup>2</sup>From Carter, Driscoll, Hamade, and Jarrell (2001). Estimates are based strictly on estimated annual recharge and are intended only for estimation of long-term averages of springflow.

<sup>3</sup>From Carter, Driscoll, Hamade, and Jarrell (2001).

Driscoll and Carter (2001) developed average budgets for the Madison and Minnelusa aquifer for 1950-98 for the Black Hills area of South Dakota (study area) and for the Black Hills area of South Dakota and Wyoming (expanded area) (table 14). The budget for the study area includes an estimate of headwater springflow (78 ft<sup>3</sup>/s) that was obtained by applying estimates of precipitation recharge to the area east of the ground-water divide on the Limestone Plateau (fig. 50). "Net recharge" of 214 ft<sup>3</sup>/s was calculated by subtracting headwater springflow from the sum of streamflow and precipitation recharge. A breakdown between wells and artesian springs (28 and 128 ft<sup>3</sup>/s, respectively) also is provided.

Table 14 also provides a budget for 1950-98 for an expanded area that includes large outcrops areas in Wyoming (fig. 54). For the expanded area, average

precipitation recharge (271 ft<sup>3</sup>/s) is considerably larger than for the study area; however, average streamflow recharge in the expanded area (98 ft<sup>3</sup>/s) is only slightly larger. Average headwater springflow (72 ft<sup>3</sup>/s) is slightly smaller because measured average flows of about 6 ft<sup>3</sup>/s for Beaver and Cold Springs Creek are excluded. Both streams originate as headwater springs in South Dakota; however, both streams are depleted by streamflow losses that provide recharge to the Minnelusa aquifer just downstream (west) of the Wyoming border. Artesian springflow (169 ft<sup>3</sup>/s) is larger and primarily accounts for artesian springflow measured along Stockade Beaver Creek and Sand Creek (fig. 34). Average net ground-water outflow (100 ft<sup>3</sup>/s) is larger and reflects additional recharge within the expanded area.

**Table 14.** Average hydrologic budgets for the Madison and Minnelusa aquifers

[From Carter, Driscoll, Hamade, and Jarrell (2001) and Driscoll and Carter (2001)]

Units	Streamflow recharge	Precipitation recharge	Headwater springflow	Net recharge	Well withdrawals	Artesian springflow	Net ground-water outflow from study area/expanded area
<b>Black Hills of South Dakota (study area), water years 1950-98</b>							
Acre-feet	66,600	144,900	56,500	155,000	20,300	92,800	41,900
Cubic feet per second	92	200	<sup>1</sup> 78	214	<sup>2</sup> 28	128	58
<b>Black Hills of South Dakota and Wyoming (expanded area), water years 1950-98</b>							
Acre-feet	71,000	196,300	52,200	215,100	20,300	122,400	72,400
Cubic feet per second	98	271	72	297	<sup>2</sup> 28	169	100
<b>Black Hills of South Dakota and Wyoming (expanded area), water years 1987-96</b>							
Acre-feet	75,300	210,800	56,500	229,600	20,300	136,900	72,400
Cubic feet per second	104	291	<sup>1</sup> 78	317	28	189	100

<sup>1</sup>Includes 6 cubic feet per second of discharge for Beaver Creek and Cold Springs Creek in South Dakota, which subsequently recharges Minnelusa aquifer a short distance downstream in Wyoming. Thus, this flow is treated as a discharge for South Dakota; however, discharge and recharge are offsetting when both South Dakota and Wyoming are considered.

<sup>2</sup>Identical estimate used for well withdrawals in both areas. Areas considered in Wyoming primarily are recharge areas, where well withdrawals are minor.

Precipitation recharge accounts for about 73 percent of the recharge in the expanded area. Artesian springflow is the single largest discharge component and accounts for about 46 percent of the total outflows for the expanded area. Headwater springflow accounts for about 20 percent of the total outflow for the expanded area. Thus, most of the total outflow from the Madison and Minnelusa aquifers is from springflow, which then provides flow to area streams. Ground water flowing out of the expanded area accounts for about 27 percent of the total outflows. Well withdrawals account for about 8 percent of the total outflows.

Carter, Driscoll, Hamade, and Jarrell (2001) computed an average hydrologic budget for 1987-96 for the Black Hills of South Dakota and Wyoming (expanded area) (table 14). For this period, change in storage was assumed equal to zero based on well hydrographs. Total springflow (including headwater and artesian springflow) averaged 267 ft<sup>3</sup>/s, which constitutes about 68 percent of estimated recharge; artesian springflow of 189 ft<sup>3</sup>/s was the single largest outflow component.

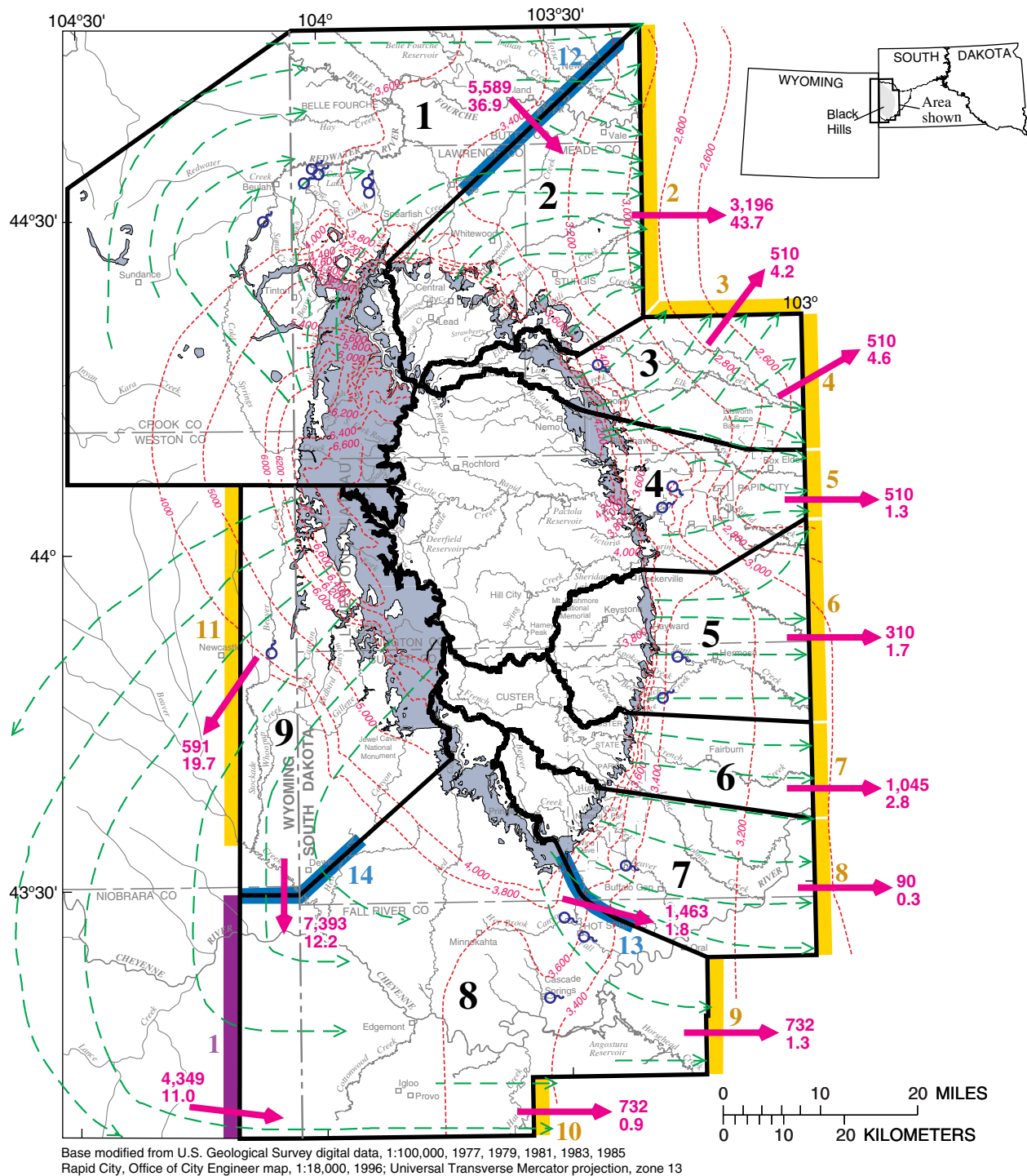
Hydrologic budgets also were quantified by Carter, Driscoll, Hamade, and Jarrell (2001) for nine subareas (figs. 69 and 70) for periods of decreasing storage (1987-92) and increasing storage (1993-96), with changes in storage assumed equal but opposite (table 15). For most subareas, net ground-water outflow exceeds inflow, and ranges from 5.9 ft<sup>3</sup>/s in the area east of Rapid City (subarea 4) to 48.6 ft<sup>3</sup>/s along the southwestern flanks of the Black Hills (subarea 9). Net ground-water inflow exceeds outflow for two subareas where the discharge of large artesian springs exceeds estimated recharge within subareas (subareas 7 and 8).

Detailed budgets developed for the nine subareas included estimates of transmissivity and flow components for the individual aquifers at specific flow zones (figs. 69 and 70). The net outflow and inflows from the subarea budgets were used with Darcy's Law to estimate transmissivity and flow across exterior flow zones corresponding with parts of the study area boundary and interior flow zones between subareas.

For estimation purposes, it was assumed that transmissivities of the Madison and Minnelusa aquifers are equal in corresponding flow zones. The resulting transmissivity estimates ranged from about 100 to 7,400 ft<sup>2</sup>/d, which are consistent with estimates from other previous investigations (table 2). The highest transmissivity estimates are for areas in the northern and southwestern parts of the study area, and the lowest transmissivity estimates are along the eastern study area boundary. Because the transmissivity estimates presented by Carter, Driscoll, Hamade, and Jarrell (2001) are averages over large areas, much larger spatial variability in actual transmissivities can be expected.

The large changes in storage (table 15) for subarea 2 (about 69,000 acre-ft) result primarily from a large net outflow rate and a large differential in streamflow recharge rates between the dry and wet periods. The large storage change is consistent with large water-level fluctuations for observation wells in this subarea. In comparison, changes in storage are much smaller for subareas 3 and 5, both of which have much smaller differentials in both streamflow and precipitation recharge rates. Both of these subareas are influenced by artesian springs with highly variable discharge rates relative to most other artesian springs. Water-level data for wells in subarea 5 are sparse; however, hydrographs for wells in subarea 3 show relatively small water-level fluctuations.

Budgets for subareas in the southern Black Hills are consistent with geochemical interpretations (Naus and others, 2001), which indicate long flowpaths along the western and southwestern flanks contributing to large artesian springs in the area, as discussed in a following section. The average discharge of Beaver Creek Spring in subarea 7 exceeds estimated recharge for this subarea and probably is influenced by outflow from subarea 8, which is consistent with geochemical information. Similarly, discharge of artesian springs in subarea 8 is much larger than recharge in this subarea. Outflow from subarea 9 is a probable source for inflow to subarea 8, which again is substantiated by geochemical information.

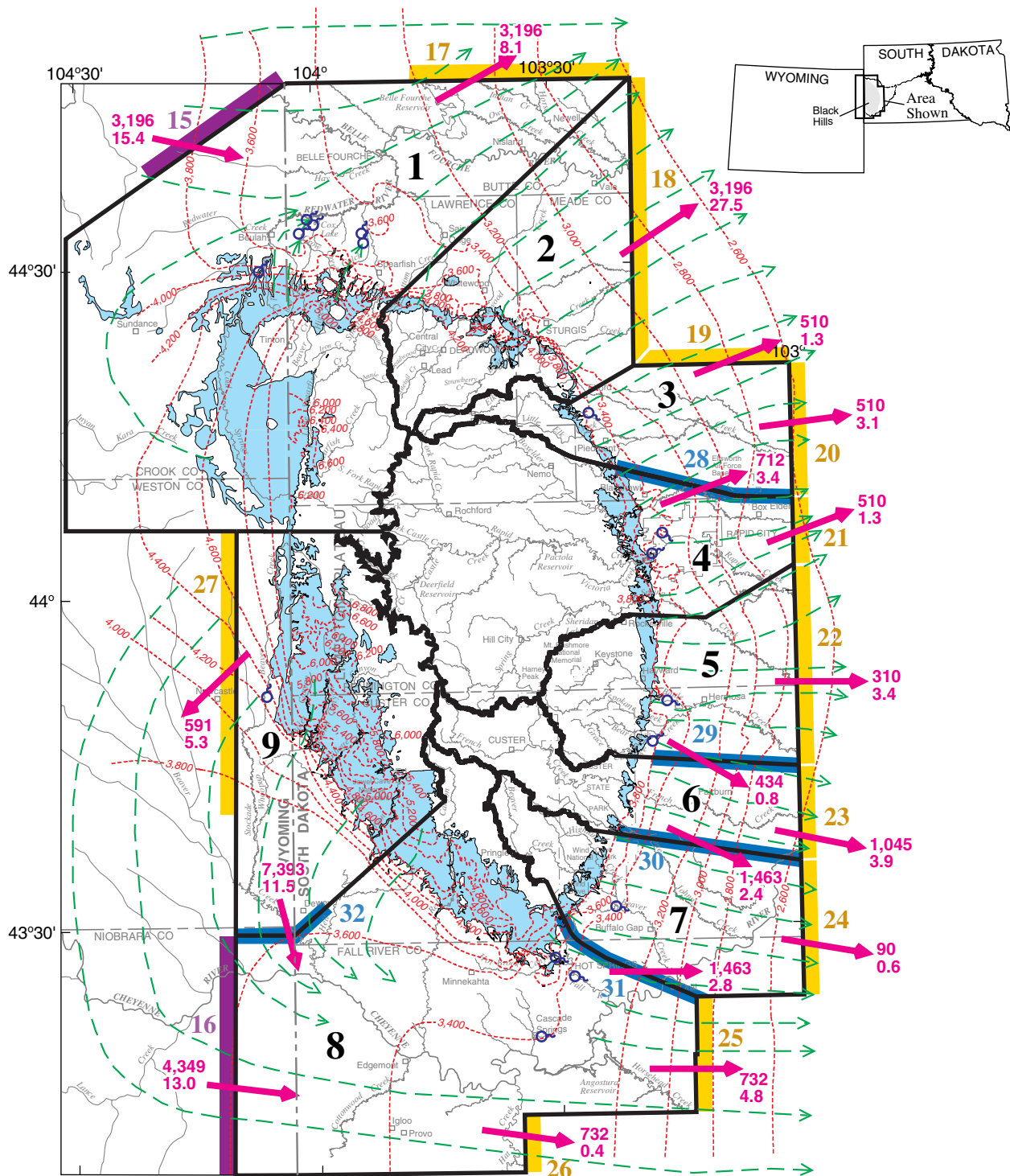


**EXPLANATION**

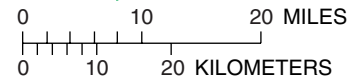
- OUTCROP OF MADISON LIMESTONE (from Strobel and others, 1999; DeWitt and others, 1989)
- 4,000 -- POTENTIOMETRIC CONTOUR--Shows altitude at which water would have stood in tightly cased, nonpumping wells (modified from Strobel and others, 2000a; Greene and Rahn, 1995). Contour interval 200 feet. Dashed where inferred. Datum is sea level
- > GENERAL DIRECTION OF GROUND-WATER FLOW
- 8 SUBAREA--Number is subarea number
- 1 EXTERIOR INFLOW ZONE--Area where ground water is assumed to be entering the study area. Number is zone number
- 10 EXTERIOR OUTFLOW ZONE--Area where ground water is assumed to be exiting the study area. Number is zone number
- 12 INTERIOR SUBAREA FLOW ZONE--Area where ground water is assumed to be crossing subarea boundaries. Number is zone number
- ➔ DIRECTION OF FLOW ACROSS FLOW ZONE--Upper number is transmissivity estimate in feet squared per day; lower number is estimated flow in cubic feet per second
- ♂ LARGE ARTESIAN SPRING

**Figure 69.** Subareas, generalized ground-water flow directions, and flow zones for the Madison aquifer. Estimated transmissivities and flow components for flow zones also are shown (from Carter, Driscoll, Hamade, and Jarrell, 2001).





Base modified from U.S. Geological Survey digital data, 1:100,000, 1977, 1979, 1981, 1983, 1985  
 Rapid City, Office of City Engineer map, 1:18,000, 1996; Universal Transverse Mercator projection, zone 13



### EXPLANATION

- OUTCROP OF MINNELUSA FORMATION (from Strobel and others, 1999; DeWitt and others, 1989)
- 4,000 -- POTENTIOMETRIC CONTOUR--Shows altitude at which water would have stood in tightly cased, nonpumping wells (modified from Strobel and others, 2000b; Downie and Dinwiddie, 1988). Contour interval 200 feet, where appropriate. Dashed where inferred. Datum is sea level
- > GENERAL DIRECTION OF GROUND-WATER FLOW
- 8 SUBAREA--Number is subarea number
- 15 EXTERIOR INFLOW ZONE--Area where ground water is assumed to be entering the study area. Number is zone number
- 25 EXTERIOR OUTFLOW ZONE--Area where ground water is assumed to be exiting the study area. Number is zone number
- 30 INTERIOR FLOW ZONE--Area where ground water is assumed to be crossing subarea boundaries. Number is zone number
- 510  
3.1 → DIRECTION OF FLOW ACROSS FLOW ZONE--Upper number is transmissivity estimate in feet squared per day; lower number is estimated flow in cubic feet per second
- ♂ LARGE ARTESIAN SPRING

**Figure 70.** Subareas, generalized ground-water flow directions, and flow zones for the Minnelusa aquifer. Estimated transmissivities and flow components for flow zones also are shown (from Carter, Driscoll, Hamade, and Jarrell, 2001).

**Table 15.** Hydrologic budgets, by subareas, for the Madison and Minnelusa aquifers in the Black Hills area, water years 1987-96

[From Carter, Driscoll, Hamade, and Jarrell (2001). ft<sup>3</sup>/s, cubic feet per second; acre-ft, acre-feet]

Water year	Inflows (ft <sup>3</sup> /s)			Outflows (ft <sup>3</sup> /s)			Sum (ft <sup>3</sup> /s)		Change in storage	
	Stream-flow recharge	Precipitation recharge	Net ground-water inflow	Artesian spring-flow	Well withdrawals	Net ground-water outflow	Inflows	Outflows	ft <sup>3</sup> /s	acre-ft
<b>Subarea 1</b>										
1987	8.6	64.8	0.0	101.8	11.0	29.6	73.4	142.4	-69.0	-49,961
1988	5.9	53.9	.0	94.8	12.6	29.6	59.8	137.0	-77.2	-55,898
1989	6.1	65.5	.0	75.5	11.7	29.6	71.6	116.8	-45.2	-32,728
1990	7.5	83.9	.0	78.8	12.2	29.6	91.4	120.6	-29.2	-21,143
1991	8.5	122.7	.0	81.4	10.9	29.6	131.2	121.9	9.3	6,734
1992	6.6	86.5	.0	76.0	11.3	29.6	93.1	116.9	-23.8	-17,233
Average/sum <sup>1</sup> 1987-92	7.2	79.6	.0	84.7	11.6	29.6	86.8	125.9	-39.2	<sup>1</sup> -170,228
1993	9.8	170.2	.0	80.6	9.1	29.6	180.0	119.3	60.7	43,951
1994	11.3	100.7	.0	93.6	10.6	29.6	112.0	133.8	-21.8	-15,785
1995	15.9	260.0	.0	103.9	9.4	29.6	275.9	142.9	133.0	96,301
1996	16.1	202.9	.0	116.7	9.6	29.6	219.0	155.9	63.1	45,689
Average/sum <sup>1</sup> 1993-96	13.3	183.5	.0	98.7	9.7	29.6	196.7	138.0	58.8	<sup>1</sup> 170,156
Average/sum <sup>1</sup> 1987-96	9.6	121.1	.0	90.3	10.8	29.6	130.7	130.8	.0	<sup>1</sup> -72
<b>Subarea 2</b>										
1987	27.5	6.1	.0	.0	3.7	34.2	33.6	37.9	-4.3	-3,113
1988	5.8	5.9	.0	.0	4.2	34.2	11.7	38.4	-26.7	-19,333
1989	9.2	6.2	.0	.0	3.8	34.2	15.4	38.0	-22.6	-16,364
1990	15.5	5.8	.0	.0	4.1	34.2	21.3	38.3	-17.0	-12,309
1991	23.8	8.9	.0	.0	3.7	34.2	32.7	37.9	-5.2	-3,765
1992	12.3	5.7	.0	.0	3.8	34.2	18.0	38.0	-20.0	-14,481
Average/sum <sup>1</sup> 1987-92	15.7	6.4	.0	.0	3.9	34.2	22.1	38.1	-16.0	<sup>1</sup> -69,366
1993	32.9	16.0	.0	.0	3.1	34.2	48.9	37.3	11.6	8,399
1994	35.4	5.9	.0	.0	3.6	34.2	41.3	37.8	3.5	2,534
1995	58.5	31.7	.0	.0	3.2	34.2	90.2	37.4	52.8	38,231
1996	49.7	16.0	.0	.0	3.3	34.2	65.7	37.5	28.2	20,419
Average/sum <sup>1</sup> 1993-96	44.1	17.4	.0	.0	3.3	34.2	61.5	37.5	24.0	<sup>1</sup> 69,583
Average/sum <sup>1</sup> 1987-96	27.1	10.8	.0	.0	3.7	34.2	37.9	37.9	.0	<sup>1</sup> 217

**Table 15.** Hydrologic budgets, by subareas, for the Madison and Minnelusa aquifers in the Black Hills area, water years 1987-96—Continued

[From Carter, Driscoll, Hamade, and Jarrell (2001). ft<sup>3</sup>/s, cubic feet per second; acre-ft, acre-feet]

Water year	Inflows (ft <sup>3</sup> /s)			Outflows (ft <sup>3</sup> /s)			Sum (ft <sup>3</sup> /s)		Change in storage	
	Stream-flow recharge	Precipitation recharge	Net ground-water inflow	Artesian spring-flow	Well withdrawals	Net ground-water outflow	Inflows	Outflows	ft <sup>3</sup> /s	acre-ft
<b>Subarea 3</b>										
1987	10.6	1.6	0.0	1.6	0.6	9.8	12.2	12.0	0.2	145
1988	2.5	1.3	.0	.3	.6	9.8	3.8	10.7	-6.9	-4,996
1989	2.7	2.1	.0	.0	.6	9.8	4.8	10.4	-5.6	-4,055
1990	8.6	2.1	.0	.0	.6	9.8	10.7	10.4	.3	217
1991	9.1	4.6	.0	.1	.6	9.8	13.7	10.5	3.2	2,317
1992	5.6	1.8	.0	.0	.6	9.8	7.4	10.4	-3.0	-2,172
Average/sum <sup>1</sup> 1987-92	6.5	2.3	.0	.3	.6	9.8	8.8	10.7	-2.0	<sup>1</sup> -8,544
1993	10.0	5.3	.0	.1	.6	9.8	15.3	10.5	4.8	3,476
1994	10.9	1.7	.0	.4	.6	9.8	12.6	10.8	1.8	1,303
1995	12.0	10.3	.0	8.6	.6	9.8	22.3	19.0	3.3	2,389
1996	13.9	6.3	.0	8.2	.6	9.8	20.2	18.6	1.6	1,159
Average/sum <sup>1</sup> 1993-96	11.7	5.9	.0	4.3	.6	9.8	17.6	14.7	2.9	<sup>1</sup> 8,327
Average/sum <sup>1</sup> 1987-96	8.6	3.7	.0	1.9	.6	9.8	12.3	12.3	.0	<sup>1</sup> -217
<b>Subarea 4</b>										
1987	33.3	2.7	.0	25.6	4.3	5.9	36.0	35.8	.2	145
1988	17.3	1.0	.0	25.6	4.2	5.9	18.3	35.7	-17.4	-12,599
1989	15.6	3.9	.0	25.6	3.4	5.9	19.5	34.9	-15.4	-11,151
1990	24.1	3.7	.0	25.6	5.0	5.9	27.8	36.5	-8.7	-6,299
1991	33.7	10.3	.0	25.6	6.7	5.9	44.0	38.2	5.8	4,200
1992	25.9	3.2	.0	25.6	10.5	5.9	29.1	42.0	-12.9	-9,340
Average/sum <sup>1</sup> 1987-92	25.0	4.1	.0	25.6	5.7	5.9	29.1	37.2	-8.1	<sup>1</sup> -35,045
1993	43.3	8.4	.0	25.8	10.2	5.9	51.7	41.9	9.8	7,096
1994	40.3	1.4	.0	25.6	11.1	5.9	41.7	42.6	-0.9	-652
1995	47.5	12.3	.0	27.1	9.1	5.9	59.8	42.1	17.7	12,816
1996	55.8	9.6	.0	30.1	7.6	5.9	65.4	43.6	21.8	15,785
Average/sum <sup>1</sup> 1993-96	46.7	7.9	.0	27.2	9.5	5.9	54.7	42.6	12.1	<sup>1</sup> 35,045
Average/sum <sup>1</sup> 1987-96	33.7	5.7	.0	26.2	7.2	5.9	39.3	39.3	.0	<sup>1</sup> 0

**Table 15.** Hydrologic budgets, by subareas, for the Madison and Minnelusa aquifers in the Black Hills area, water years 1987-96—Continued

[From Carter, Driscoll, Hamade, and Jarrell (2001). ft<sup>3</sup>/s, cubic feet per second; acre-ft, acre-feet]

Water year	Inflows (ft <sup>3</sup> /s)			Outflows (ft <sup>3</sup> /s)			Sum (ft <sup>3</sup> /s)		Change in storage	
	Stream-flow recharge	Precipitation recharge	Net ground-water inflow	Artesian spring-flow	Well withdrawals	Net ground-water outflow	Inflows	Outflows	ft <sup>3</sup> /s	acre-ft
<b>Subarea 5</b>										
1987	12.8	1.3	0.0	6.2	1.6	6.0	14.1	13.8	0.3	217
1988	2.4	.6	.0	2.4	1.6	6.0	3.0	10.0	-7.0	-5,068
1989	3.1	2.2	.0	1.2	1.6	6.0	5.3	8.8	-3.5	-2,534
1990	10.6	3.6	.0	1.6	1.6	6.0	14.2	9.2	5.0	3,620
1991	12.9	4.5	.0	3.5	1.6	6.0	17.4	11.1	6.3	4,562
1992	7.9	2.0	.0	4.5	1.6	6.0	9.9	12.1	-2.2	-1,593
Average/sum <sup>1</sup> 1987-92	8.3	2.4	.0	3.2	1.6	6.0	10.7	10.8	-0.2	<sup>1</sup> -796
1993	17.3	4.9	.0	7.1	1.6	6.0	22.2	14.7	7.5	5,430
1994	10.2	1.3	.0	10.8	1.7	6.0	11.5	18.5	-7.0	-5,068
1995	18.7	7.2	.0	11.3	1.6	6.0	25.9	18.9	7.0	5,068
1996	18.0	4.7	.0	21.0	1.7	6.0	22.7	28.7	-6.0	-4,344
Average/sum <sup>1</sup> 1993-96	16.1	4.5	.0	12.6	1.7	6.0	20.6	20.2	.4	<sup>1</sup> 1,086
Average/sum <sup>1</sup> 1987-96	11.4	3.2	.0	7.0	1.6	6.0	14.6	14.6	.0	<sup>1</sup> 290
<b>Subarea 6</b>										
1987	7.8	.3	.0	.0	.0	8.3	8.1	8.3	-0.2	-145
1988	2.7	.2	.0	.0	.0	8.3	2.9	8.3	-5.4	-3,910
1989	1.6	.6	.0	.0	.0	8.3	2.2	8.3	-6.1	-4,417
1990	5.1	.8	.0	.0	.0	8.3	5.9	8.3	-2.4	-1,738
1991	7.8	.9	.0	.0	.0	8.3	8.7	8.3	.4	290
1992	5.5	.7	.0	.0	.0	8.3	6.2	8.3	-2.1	-1,521
Average/sum <sup>1</sup> 1987-92	5.1	.6	.0	.0	.0	8.3	5.7	8.3	-2.6	<sup>1</sup> -11,440
1993	9.2	1.3	.0	.0	.0	8.3	10.5	8.3	2.2	1,593
1994	7.4	.3	.0	.0	.0	8.3	7.7	8.3	-0.6	-434
1995	13.0	2.5	.0	.0	.0	8.3	15.5	8.3	7.2	5,213
1996	13.9	1.5	.0	.0	.0	8.3	15.4	8.3	7.1	5,141
Average/sum <sup>1</sup> 1993-96	10.9	1.4	.0	.0	.0	8.3	12.3	8.3	4.0	<sup>1</sup> 11,513
Average/sum <sup>1</sup> 1987-96	7.4	.9	.0	.0	.0	8.3	8.3	8.3	.0	<sup>1</sup> 72

**Table 15.** Hydrologic budgets, by subareas, for the Madison and Minnelusa aquifers in the Black Hills area, water years 1987-96—Continued

[From Carter, Driscoll, Hamade, and Jarrell (2001). ft<sup>3</sup>/s, cubic feet per second; acre-ft, acre-feet]

Water year	Inflows (ft <sup>3</sup> /s)			Outflows (ft <sup>3</sup> /s)			Sum (ft <sup>3</sup> /s)		Change in storage	
	Stream-flow recharge	Precipitation recharge	Net ground-water inflow	Artesian spring-flow	Well withdrawals	Net ground-water outflow	Inflows	Outflows	ft <sup>3</sup> /s	acre-ft
<b>Subarea 7</b>										
1987	2.0	0.6	6.1	10.0	0.1	0.0	8.7	10.1	-1.4	-1,014
1988	.4	.4	6.1	10.0	.1	.0	6.9	10.1	-3.2	-2,317
1989	.4	.6	6.1	9.0	.1	.0	7.1	9.1	-2.0	-1,448
1990	1.0	.9	6.1	9.0	.1	.0	8.0	9.1	-1.1	-796
1991	1.6	1.1	6.1	8.1	.1	.0	8.8	8.2	.6	434
1992	1.0	1.2	6.1	8.0	.1	.0	8.3	8.1	.2	145
Average/sum <sup>1</sup> 1987-92	1.1	.8	6.1	9.0	.1	.0	8.0	9.1	-1.2	<sup>1</sup> -4,996
1993	2.2	2.1	6.1	9.1	.1	.0	10.4	9.2	1.2	869
1994	2.3	.6	6.1	9.5	.1	.0	9.0	9.6	-0.6	-434
1995	6.1	4.2	6.1	12.5	.1	.0	16.4	12.6	3.8	2,751
1996	6.1	1.2	6.1	11.1	.1	.0	13.4	11.2	2.2	1,593
Average/sum <sup>1</sup> 1993-96	4.2	2.0	6.1	10.6	.1	.0	12.3	10.7	1.7	<sup>1</sup> 4,779
Average/sum <sup>1</sup> 1987-96	2.3	1.3	6.1	9.6	.1	.0	9.7	9.7	.0	<sup>1</sup> -217
<b>Subarea 8</b>										
1987	5.9	3.2	35.6	45.4	1.8	.0	44.7	47.2	-2.5	-1,810
1988	1.5	2.2	35.6	44.1	1.8	.0	39.3	45.9	-6.6	-4,779
1989	1.6	3.8	35.6	43.1	1.8	.0	41.0	44.9	-3.9	-2,824
1990	3.9	5.4	35.6	44.1	1.9	.0	44.9	46.0	-1.1	-796
1991	5.5	5.7	35.6	43.1	1.8	.0	46.8	44.9	1.9	1,376
1992	1.6	5.2	35.6	42.9	1.8	.0	42.4	44.7	-2.3	-1,665
Average/sum <sup>1</sup> 1987-92	3.3	4.3	35.6	43.8	1.8	.0	43.2	45.6	-2.4	<sup>1</sup> -10,499
1993	4.1	10.8	35.6	42.1	1.8	.0	50.5	43.9	6.6	4,779
1994	2.4	2.3	35.6	44.0	1.9	.0	40.3	45.9	-5.6	-4,055
1995	11.9	14.6	35.6	46.3	1.9	.0	62.1	48.2	13.9	10,065
1996	6.0	7.5	35.6	47.5	1.8	.0	49.1	49.3	-0.2	-145
Average/sum <sup>1</sup> 1993-96	6.1	8.8	35.6	45.0	1.9	.0	50.5	46.8	3.7	<sup>1</sup> 10,644
Average/sum <sup>1</sup> 1987-96	4.4	6.1	35.6	44.3	1.8	.0	46.1	46.1	.0	<sup>1</sup> 145

**Table 15.** Hydrologic budgets, by subareas, for the Madison and Minnelusa aquifers in the Black Hills area, water years 1987-96—Continued

[From Carter, Driscoll, Hamade, and Jarrell (2001). ft<sup>3</sup>/s, cubic feet per second; acre-ft, acre-feet]

Water year	Inflows (ft <sup>3</sup> /s)			Outflows (ft <sup>3</sup> /s)			Sum (ft <sup>3</sup> /s)		Change in storage	
	Stream-flow recharge	Precipitation recharge	Net ground-water inflow	Artesian spring-flow	Well withdrawals	Net ground-water outflow	Inflows	Outflows	ft <sup>3</sup> /s	acre-ft
Subarea 9										
1987	0.0	24.6	0.0	9.0	2.2	48.6	24.6	59.8	-35.2	-25,487
1988	.0	20.7	.0	9.0	2.2	48.6	20.7	59.8	-39.1	-28,311
1989	.0	35.3	.0	9.0	2.2	48.6	35.3	59.8	-24.5	-17,740
1990	.0	46.1	.0	9.0	2.2	48.6	46.1	59.8	-13.7	-9,920
1991	.0	73.1	.0	8.8	2.2	48.6	73.1	59.6	13.5	9,775
1992	.0	44.6	.0	8.9	2.2	48.6	44.6	59.7	-15.1	-10,933
Average/sum <sup>1</sup> 1987-92	.0	40.7	.0	9.0	2.2	48.6	40.7	59.8	-19.0	<sup>1</sup> -82,616
1993	.0	98.2	.0	9.1	2.2	48.6	98.2	59.9	38.3	27,732
1994	.0	40.2	.0	9.7	2.3	48.6	40.2	60.6	-20.4	-14,771
1995	.0	106.4	.0	11.8	2.2	48.6	106.4	62.6	43.8	31,714
1996	.0	114.3	.0	11.3	2.3	48.6	114.3	62.2	52.1	37,724
Average/sum <sup>1</sup> 1993-96	.0	89.8	.0	10.5	2.3	48.6	89.8	61.3	28.5	<sup>1</sup> 82,399
Average/sum <sup>1</sup> 1987-96	.0	60.4	.0	9.6	2.2	48.6	60.4	60.4	.0	<sup>1</sup> -217

<sup>1</sup>Sum used for change in storage in acre-feet.

### Budgets for Other Bedrock Aquifers

Recharge estimates for the other bedrock aquifers consist only of precipitation recharge, which was derived by Driscoll and Carter (2001) using the yield-efficiency algorithm. Total yield, which is the sum of runoff plus recharge, was computed by applying the yield-efficiency algorithm to the estimates of precipitation on outcrops of the various bedrock formations.

Individual ground-water budgets and an overall budget for all bedrock aquifers in the study area are presented in table 16. The Madison and Minnelusa aquifers, which have the largest outcrop areas of the major aquifers in the study area, dominate the overall ground-water budgets. In contrast, runoff from aquifer outcrops is dominated by the crystalline core area, with negligible runoff from outcrops of the Madison, Minnelusa,

or Minnekahta aquifers. Combined recharge for all bedrock aquifers was estimated as 348 ft<sup>3</sup>/s, of which about 84 percent is recharge to the Madison and Minnelusa aquifers. Total well withdrawals and springflow account for 259 ft<sup>3</sup>/s, of which about 90 percent is from the Madison and Minnelusa aquifers. Net ground-water outflow from the study area was calculated as 89 ft<sup>3</sup>/s and ranges from zero (assumed) for the crystalline core aquifers to about 58 ft<sup>3</sup>/s (65 percent) for the Madison and Minnelusa aquifers. For the Deadwood aquifer, well withdrawals and springflow were estimated as 14 ft<sup>3</sup>/s, which consists primarily of spring discharge in headwater areas of about 13 ft<sup>3</sup>/s. For the Madison and Minnelusa aquifers, springflow of 206 ft<sup>3</sup>/s is much larger than well withdrawals of 28 ft<sup>3</sup>/s. For all other aquifers, springflow is small and was neglected; only well withdrawals are listed in table 16.

**Table 16. Average ground-water budgets for bedrock aquifers, water years 1950-98**

[From Driscoll and Carter (2001). --, no data]

Units	Precipitation	Evapotran- spiration	Total yield	Runoff	Precipitation recharge	Streamflow recharge	Total recharge	Well with- drawals and springflow <sup>1</sup>	Net study area outflow
<b>Crystalline Core (Precambrian, Tertiary, and Other Minor Units)</b>									
Acre-feet per year	1,084,500	964,200	120,300	116,700	3,600	0	3,600	3,600	0.0
Cubic feet per second	1,497	1,331	166	161	5	0	5	5	0
Inches per year	21.10	18.76	2.34	2.27	0.07	0	0.07	--	--
<b>Deadwood</b>									
Acre-feet per year	128,200	110,100	18,100	3,600	14,500	0	14,500	10,100	4,400
Cubic feet per second	177	152	25	5	20	0	20	14	6
Inches per year	23.24	19.96	3.28	0.65	2.63	0	2.63	--	--
<b>Madison and Minnelusa</b>									
Acre-feet per year	1,021,500	876,600	144,900	0	144,900	66,600	211,500	169,500	41,900
Cubic feet per second	1,410	1,210	200	0	200	92	292	1,234	58
Inches per year	20.69	17.76	2.93	0	2.93	1.35	4.28	--	--
<b>Minnekahta</b>									
Acre-feet per year	120,300	113,800	6,500	0	6,500	0	6,500	700	5,800
Cubic feet per second	166	157	9	0	9	0	9	1	8
Inches per year	20.02	18.94	1.08	0	1.08	0	1.08	--	--
<b>Inyan Kara</b>									
Acre-feet per year	326,700	312,200	14,500	2,900	11,600	0	11,600	1,400	10,200
Cubic feet per second	451	431	20	4	16	0	16	2	14
Inches per year	17.84	17.05	0.79	0.16	0.63	0	0.63	--	--
<b>Jurassic-Sequence Semiconfining Unit</b>									
Acre-feet per year	115,900	110,000	5,800	3,600	2,200	0	2,200	700	1,500
Cubic feet per second	160	152	8	5	3	0	3	1	2
Inches per year	18.35	17.43	0.92	0.57	0.35	0	0.35	--	--
<b>Cretaceous-Sequence Confining Unit</b>									
Acre-feet per year	1,028,700	980,900	47,800	45,600	2,200	0	2,200	1,400	800
Cubic feet per second	1,420	1,354	66	63	3	0	3	2	1
Inches per year	17.24	16.44	0.80	0.76	0.04	0	0.04	--	--
<b>Overall Budget for Bedrock Aquifers</b>									
Acre-feet per year	3,825,900	3,468,000	357,900	172,400	185,500	66,600	252,100	187,600	64,600
Cubic feet per second	5,281	4,787	494	238	256	92	348	259	89
Inches per year	19.46	17.64	1.82	0.88	0.94	1.35	1.28	--	--

<sup>1</sup>Includes estimated springflow of 13 cubic feet per second for Deadwood aquifer and 206 cubic feet per second for Madison and Minnelusa aquifers. For other aquifers, springflow is considered negligible and estimates include only well withdrawals.

## Surface-Water Budgets

Surface-water budgets were developed by Driscoll and Carter (2001) by consideration of stream channels within various specified areas, for which the basic continuity equation (eq. 2) was applied. Inflows considered included stream channels crossing boundaries for specified areas and net tributary flows generated within specified areas. Because net tributary flows (flows less depletions) were considered, flow depletions such as streamflow losses or diversions were not included as outflows. Storage changes for the four large Bureau of Reclamation reservoirs (Angostura, Deerfield, Pactola, and Belle Fourche) located within the study area were considered, with records of storage changes (positive change reflects increased storage) derived primarily from Miller and Driscoll (1998). Large storage increases occurred during 1950-98 for Angostura Reservoir (completed during 1950), Pactola Reservoir (completed during 1956), and Belle Fourche Reservoir, which had very low storage during 1950.

Average surface-water budgets for 1950-98 are provided in table 17. Inflows to the study area averaged about 106 and 146 ft<sup>3</sup>/s in the Cheyenne and Belle Fourche River drainages, respectively, with combined inflows averaging about 252 ft<sup>3</sup>/s. Net tributary flows generated within the study area were estimated as about 201 and 107 ft<sup>3</sup>/s in the Cheyenne and Belle Fourche River drainages, respectively, with combined tributary flows of about 308 ft<sup>3</sup>/s. Considering storage increases of about 7 ft<sup>3</sup>/s in Bureau of Reclamation reservoirs, total outflows from the study area were estimated as about 554 ft<sup>3</sup>/s, with outflows of about 303 ft<sup>3</sup>/s for the Cheyenne River drainage and 251 ft<sup>3</sup>/s for the Belle Fourche River drainage.

The primary surface-water outflows occur along the eastern side of the study area, of which the Cheyenne and Belle Fourche Rivers constitute the largest percentage of outflows (Driscoll and Carter, 2001). Estimated outflows include combined flows of about 6 ft<sup>3</sup>/s in the Beaver Creek and Cold Springs Creek drainages, which drain a portion of the Limestone Plateau area, with flow to the west into Wyoming. Flow in both of these streams is lost to the Minnelusa Formation a short distance downstream of the Wyoming border.

## Combined Ground-Water and Surface-Water Budgets

Combined average ground- and surface-water budgets are presented in figure 71A, which includes a detailed budget that shows complex ground- and surface-water interactions, and in figure 71B, which shows a more simplified budget. These budgets also are used to show consumptive uses of water that occur within the study area. Total consumptive use within the study area from both ground-water and surface-water resources was estimated by Driscoll and Carter (2001) as 218 ft<sup>3</sup>/s, which includes well withdrawals (40 ft<sup>3</sup>/s), reservoir evaporation (38 ft<sup>3</sup>/s), and consumptive withdrawals from streams (140 ft<sup>3</sup>/s). Consumptive uses consist primarily of consumptive irrigation withdrawals, which do not include unconsumed irrigation return flows. Most well withdrawals are consumed; however, in some locations (such as Rapid City), some portion of municipal well withdrawals may be unconsumed and returned to streams via wastewater treatment effluent.

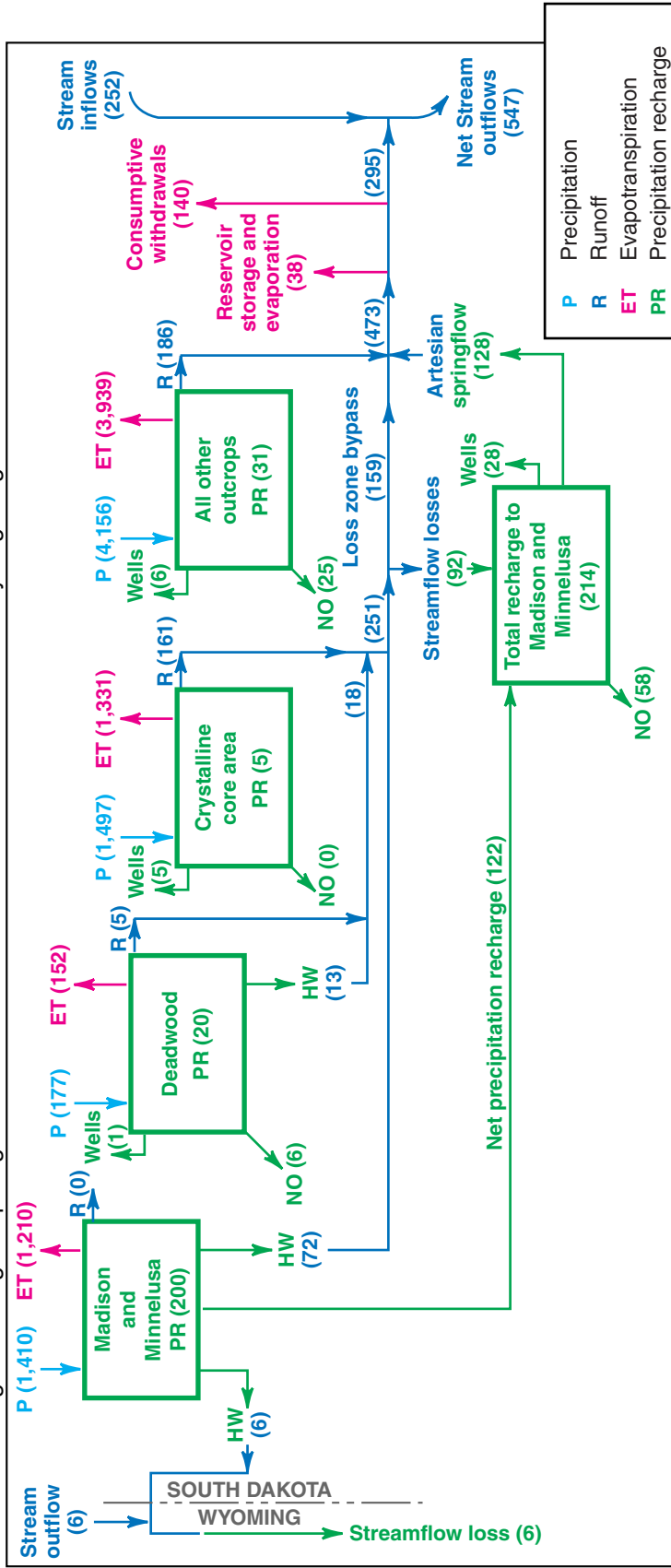
**Table 17.** Average surface-water budgets for study area, water years 1950-98

[From Driscoll and Carter (2001). All in cubic feet per second]

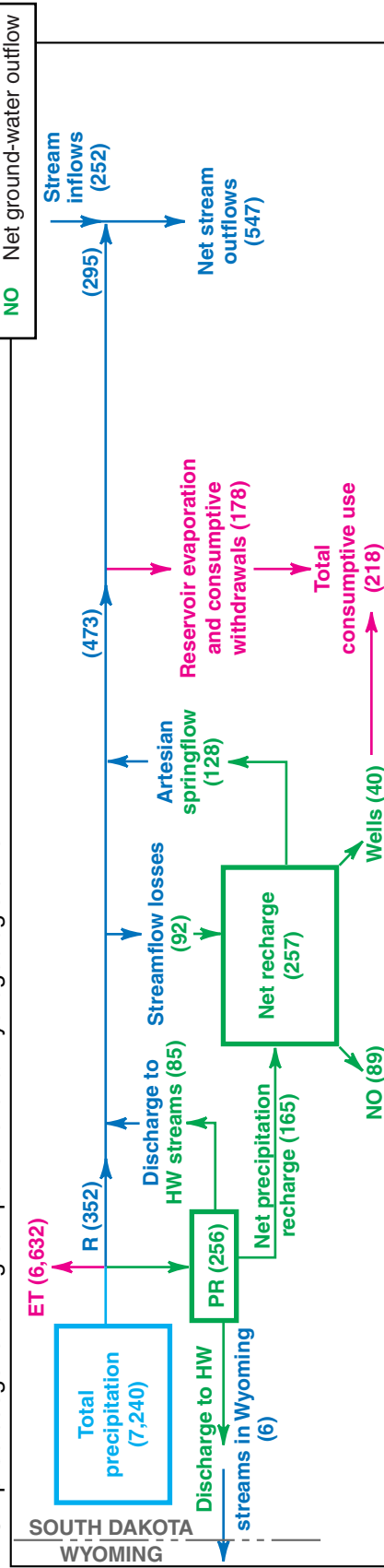
Basin	Study area inflows	+ Study area tributaries	- Change in storage	= Study area outflows
Cheyenne River	105.8	201.2	4.5	302.5
Belle Fourche River	146.4	107.3	2.7	251.0
Combined	252.2	308.5	7.2	553.5



**A** Detailed budget showing complex ground- and surface-water interactions for selected hydrogeologic units



**B** Simplified budget showing components for all hydrogeologic units



**Figure 71.** Schematic diagram showing average hydrologic budget components for study area, water years 1950-98 (from Driscoll and Carter, 2001). All values in cubic feet per second.

A schematic diagram is presented as figure 72 that shows the progression of average streamflow relative to surface geology and streamflow depletions. Streamflow upstream from loss zones to the Madison and Minnelusa aquifers averages about 251 ft<sup>3</sup>/s, which consists of headwater springflow from the Madison and Minnelusa aquifers (72 ft<sup>3</sup>/s) and Deadwood aquifer (13 ft<sup>3</sup>/s) and runoff from the Deadwood Formation (5 ft<sup>3</sup>/s) and crystalline core area (161 ft<sup>3</sup>/s). Streamflow losses to the Madison and Minnelusa aquifers average 92 ft<sup>3</sup>/s; thus, combined streamflow downstream from loss zones (loss-zone bypass) averages about 159 ft<sup>3</sup>/s.

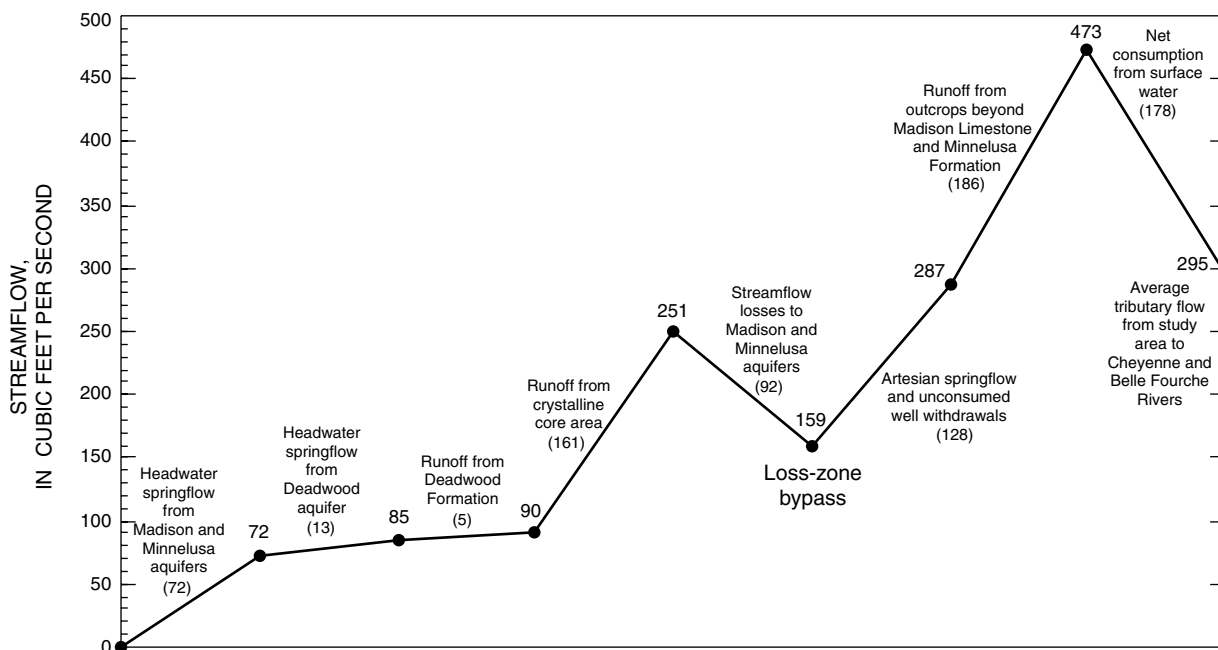
Artesian springflow (128 ft<sup>3</sup>/s) and runoff from outcrops beyond the Madison Limestone and Minnelusa Formation (186 ft<sup>3</sup>/s) provide additional streamflow beyond the loss zones (fig. 72). Thus, average streamflow prior to major depletions, which result primarily from irrigation operations, is about 473 ft<sup>3</sup>/s. Reservoir evaporation and consumptive withdrawals of 178 ft<sup>3</sup>/s reduce average tributary flows to the Cheyenne and Belle Fourche Rivers to 295 ft<sup>3</sup>/s. The tributary flows of 295 ft<sup>3</sup>/s in figure 72 differ from

the study area tributary flows of 308 ft<sup>3</sup>/s in table 12 by the reservoir storage change (7 ft<sup>3</sup>/s) and by combined flows for Beaver and Cold Springs Creeks (6 ft<sup>3</sup>/s). The flows of Beaver and Cold Springs Creeks do not contribute to flows of the Cheyenne and Belle Fourche Rivers because streamflow losses occur a short distance downstream from the Wyoming border, as previously discussed.

## Evaluation of Hydrologic Budgets

Numerous assumptions and estimates have been made in developing budgets for the complex hydrology of the Black Hills area. This section summarizes evaluations of budget components by Driscoll and Carter (2001), who concluded that methods used have provided reasonable budget estimates.

Hydrologic budgets for the Madison and Minnelusa aquifers are especially important because these aquifers dominate the overall ground-water budgets for the Black Hills area and heavily influence the surface-water budget. Estimates of streamflow recharge, which are based largely on measured values, are considered



**Figure 72.** Schematic showing generalized average streamflow (water years 1950-98) relative to surface geology and depletions (from Driscoll and Carter, 2001).

more accurate than estimates of precipitation recharge, which have relatively large uncertainty associated with use of the yield-efficiency algorithm (and the assumptions on which the procedure is based). Short-term estimates for artesian springflow, which are based primarily on measured values, have relatively small uncertainty; however, extrapolation for longer term budgets (1950-98) introduces additional uncertainty. Uncertainties are larger for estimates of headwater springflow, which are based on yield potential for inferred areas contributing to ground-water discharge. Uncertainties are small for well withdrawals; thus, most of the uncertainties for estimates of net ground-water outflow from the study area are related to uncertainties for estimates of precipitation recharge. Detailed water-budget analyses for subareas (figs. 69 and 70) provided confidence that estimates for all water-budget components are reasonable.

Budgets for other aquifers are based primarily on estimates of precipitation recharge, which were derived using the yield-efficiency algorithm. The assumed “recharge factors” used to apportion overall yield potential between runoff and recharge are another source of potential error. Considerable evidence exists that direct runoff is uncommon from outcrops of the Madison and Minnelusa aquifers; however, information regarding other aquifer outcrops is sparse.

The yield-efficiency algorithm also was used extensively in developing surface-water budgets and in estimating consumptive withdrawals for the study area. An analysis of streamflow depletion from streamflow losses indicated that estimates of total basin yield from the crystalline core area were reasonable. Evaluations of consumptive withdrawal estimates indicated that the yield-efficiency algorithm also performed well for areas beyond the Madison/Minnelusa outcrop band. Systematic biases in yield estimates undoubtedly would occur for various localized applications; however, evaluations performed have provided confidence that the algorithm systematically produces reasonable and reproducible estimates of basin yield from the spatial distribution of annual precipitation. Readers are cautioned that because of inherent, unexplained variability between annual yield and precipitation, estimates for individual years that are based on this algorithm have a relatively high level of uncertainty. Uncertainties associated with long-term estimates are much smaller, however.

## MADISON AND MINNELUSA FLOW SYSTEM

A major focus of the Black Hills Hydrology Study has been to obtain a better understanding of flow systems within the Madison and Minnelusa aquifers, which are extremely complex due to heterogeneity and anisotropy related to karst features and fractures and to interactions between the aquifers and surface-water resources. A variety of information has been considered in evaluating flowpaths, mixing conditions, and interactions. Much of the relevant background information, such as potentiometric-surface maps, hydrographs for colocated Madison and Minnelusa wells, major-ion chemistry, and hydrologic budgets, has been presented in previous sections. Background information regarding isotopes is presented in the following section.

### Isotope Information

Various isotopes were used by Naus and others (2001) in evaluating the Madison and Minnelusa flow systems. The stable isotopes of oxygen ( $^{18}\text{O}$  and  $^{16}\text{O}$ ) and hydrogen ( $^2\text{H}$ , deuterium; and  $^1\text{H}$ ) were used to evaluate ground-water flowpaths, recharge areas, and mixing conditions. The radioisotope tritium ( $^3\text{H}$ ) provided additional information for evaluation of mixing conditions and ground-water ages. Background information for these isotopes and their distributions in the Black Hills area are discussed in the following sections.

### Background Information and Composition of Recharge Water

This section presents background information regarding stable isotopes and tritium, which generally are not affected by interactions between minerals and ground water. The stable isotopes of oxygen and hydrogen are useful as flowpath tracers because of distinctive patterns in the Black Hills area resulting from meteorological influences. Tritium, which is subject to decay over time, is useful for age dating because large temporal variations of concentrations in precipitation have resulted from atmospheric testing of thermonuclear bombs during the 1950's and 1960's.

Stable isotope values are given in “delta notation,” which compares the ratio between heavy and light isotopes of a sample to that of a reference standard. Delta values are expressed as a difference, in

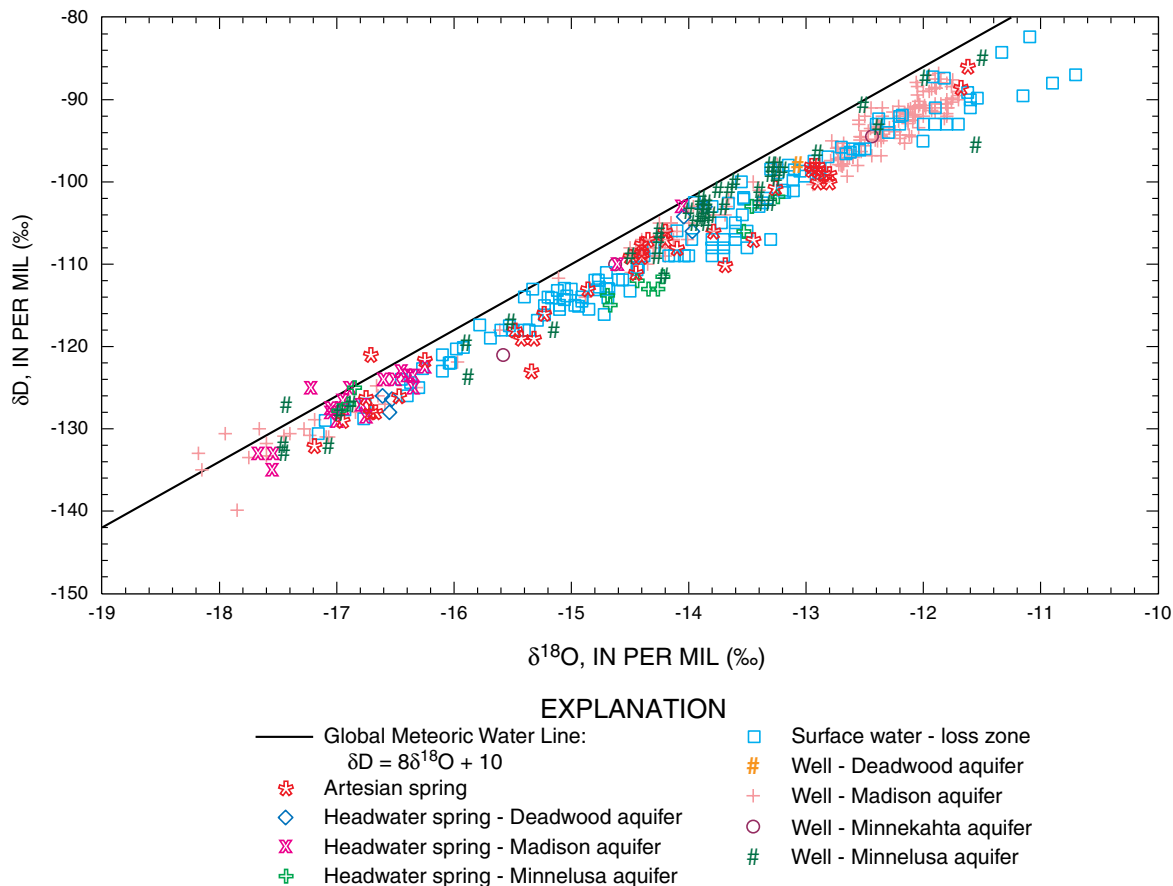
parts per thousand, or per mil (‰), from the reference standard. For example, the oxygen isotope value of a sample written in delta notation is:

$$\delta^{18}\text{O}_{\text{sample}} = \frac{{}^{18}\text{O}/{}^{16}\text{O}_{\text{sample}} - {}^{18}\text{O}/{}^{16}\text{O}_{\text{standard}}}{{}^{18}\text{O}/{}^{16}\text{O}_{\text{standard}}} \times 1,000 \text{ ‰ VSMOW.}$$

A sample with a  $\delta$  value of -20 ‰ is depleted by 20 parts per thousand (2 percent) in the heavier isotope of the element relative to the standard. In this report,  $\delta^{18}\text{O}$  ( $^{18}\text{O}/^{16}\text{O}$ ) and  $\delta\text{D}$  (deuterium/hydrogen) values are reported in per mil relative to Vienna Standard Mean Ocean Water (VSMOW) and are described as lighter and heavier in relation to each other. The lighter

values are more negative relative to the heavier values, which are less negative.

Distinct isotopic signatures can result from isotope fractionation, which results from the loss of water vapor from a cooling air mass as it passes from its oceanic source over continents. As air masses rise to higher altitudes, lower temperatures and the subsequent formation of precipitation cause fractionation to occur within the cloud, and  $^{18}\text{O}$  and deuterium (D) are partitioned preferentially into the rain or snow. The heavy isotopes thus are distilled from the vapor, which is progressively depleted in  $^{18}\text{O}$  and D (Clark and Fritz, 1997). A linear relation exists between  $\delta^{18}\text{O}$  and  $\delta\text{D}$  for samples collected in the Black Hills area (fig. 73); thus, subsequent discussions and illustrations refer only to  $\delta^{18}\text{O}$  for simplicity.



**Figure 73.** Relation between  $\delta^{18}\text{O}$  and  $\delta\text{D}$  in Black Hills samples in comparison to the Global Meteoric Water Line (Craig, 1961) (from Naus and others, 2001).

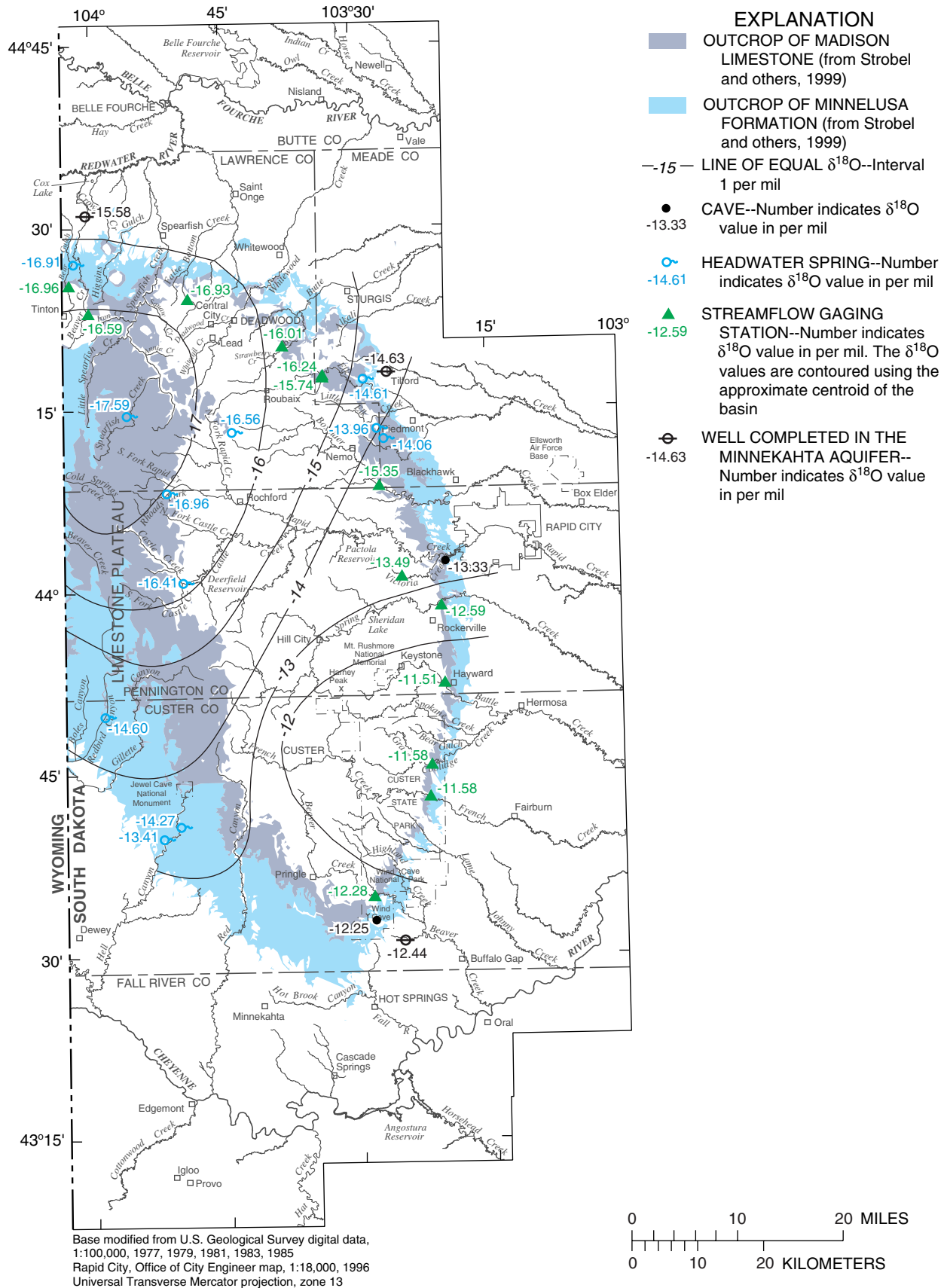
A generalized distribution of  $\delta^{18}\text{O}$  values for near-recharge areas is shown in figure 74. Sampling sites and values from which contours were derived also are shown in figure 74. Sites considered generally are located in or near recharge areas and probably are affected primarily by localized flowpaths.

In near-recharge areas,  $\delta^{18}\text{O}$  values are influenced primarily by orography and storm patterns. Precipitation in the northern Black Hills generally is isotopically lighter than in the south because of relatively high altitudes and the influence of Pacific storms that are isotopically depleted in crossing the Rocky Mountains. The generally lower altitudes in the southern Black Hills, combined with warm weather patterns from the south-southeast, result in precipitation that is isotopically heavier than in the north (Back and others, 1983; Busby and others, 1983; Greene, 1997). The resulting distribution of isotopes in near-recharge areas of the Black Hills serves as a natural tracer for ground-water flowpaths.

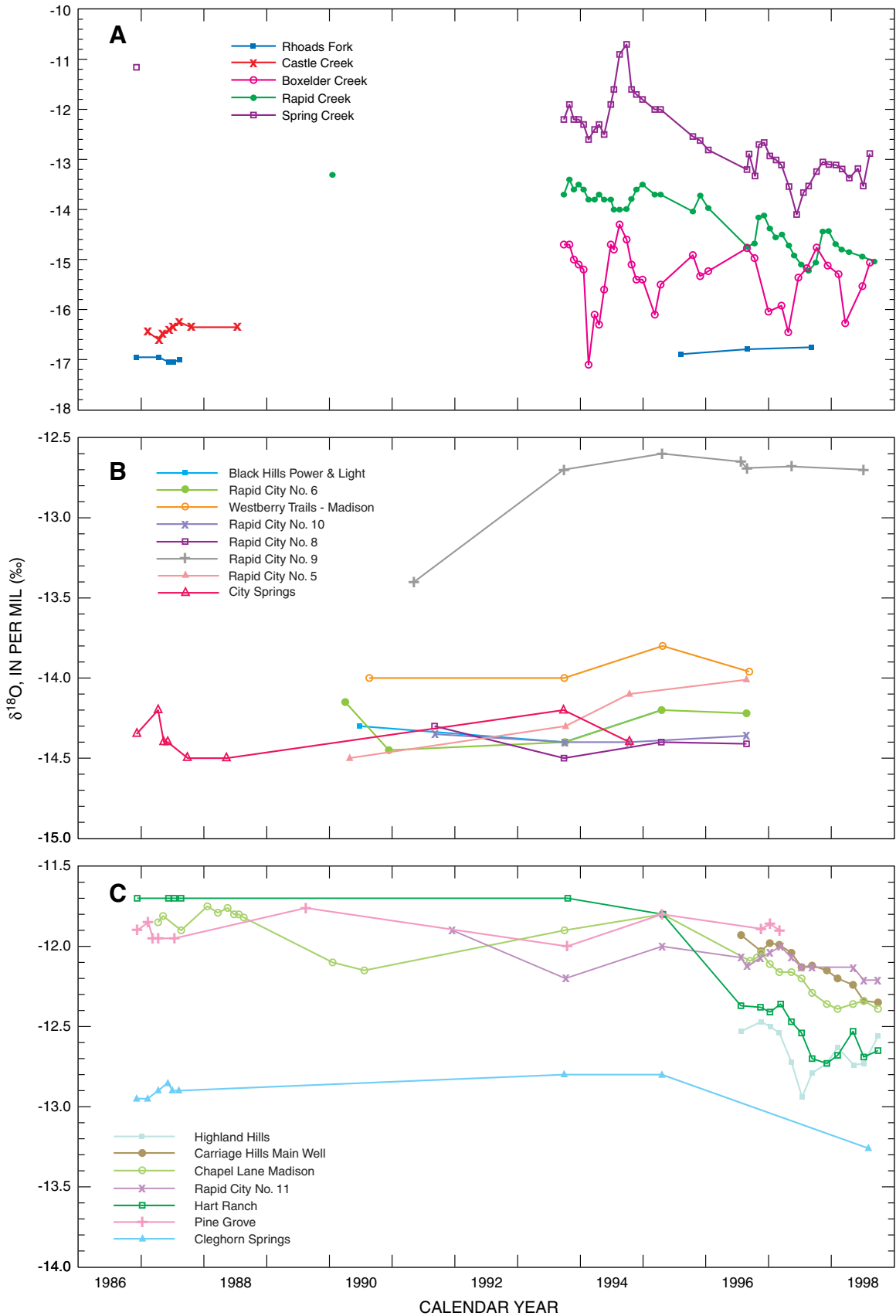
Temporal variability in  $\delta^{18}\text{O}$  values for selected surface-water and ground-water sites is shown in figure 75; locations for these sites were provided by Naus and others (2001, p. 42-44). Temporal variability for ground-water samples generally is small relative to surface-water samples (fig. 75). The temporal variability in  $\delta^{18}\text{O}$  values for selected loss-zone streams (Spring Creek, Rapid Creek, and Boxelder Creek) (figure 75A) is due to seasonal variability in isotopic composition of precipitation. Data sets for selected headwater springs (Rhoads Fork and Castle Creek) are somewhat limited, but indicate less variability because of mixing associated with ground-water storage. Thus, for the wells and headwater springs shown in figure 74, variability in  $\delta^{18}\text{O}$  was assumed by Naus and others (2001) to be small and values were considered representative of average isotopic composition in near-recharge areas.

Tritium, which beta-decays to  $^3\text{He}$  with a half-life of 12.43 years (Clark and Fritz, 1997), is produced naturally in small concentrations by cosmic radiation in the stratosphere. Naturally occurring background concentrations of tritium in continental precipitation are estimated to range from 1 to 20 TU (tritium units), depending on location (Michel, 1989). One TU is defined as one  $^3\text{H}$  atom per  $10^{18}$  atoms of hydrogen, which is equivalent to 3.19 pCi/L (picocuries per liter) in water (International Atomic Energy Agency, 1981). Because of nuclear-bomb testing during the 1950's and 1960's and a subsequent treaty limiting such tests, tritium concentrations in atmospheric water increased sharply in 1953, peaked in 1963, and then declined. Current sources of tritium, such as nuclear power production, contribute to atmospheric tritium concentrations that are slightly higher than background concentrations prior to nuclear testing.

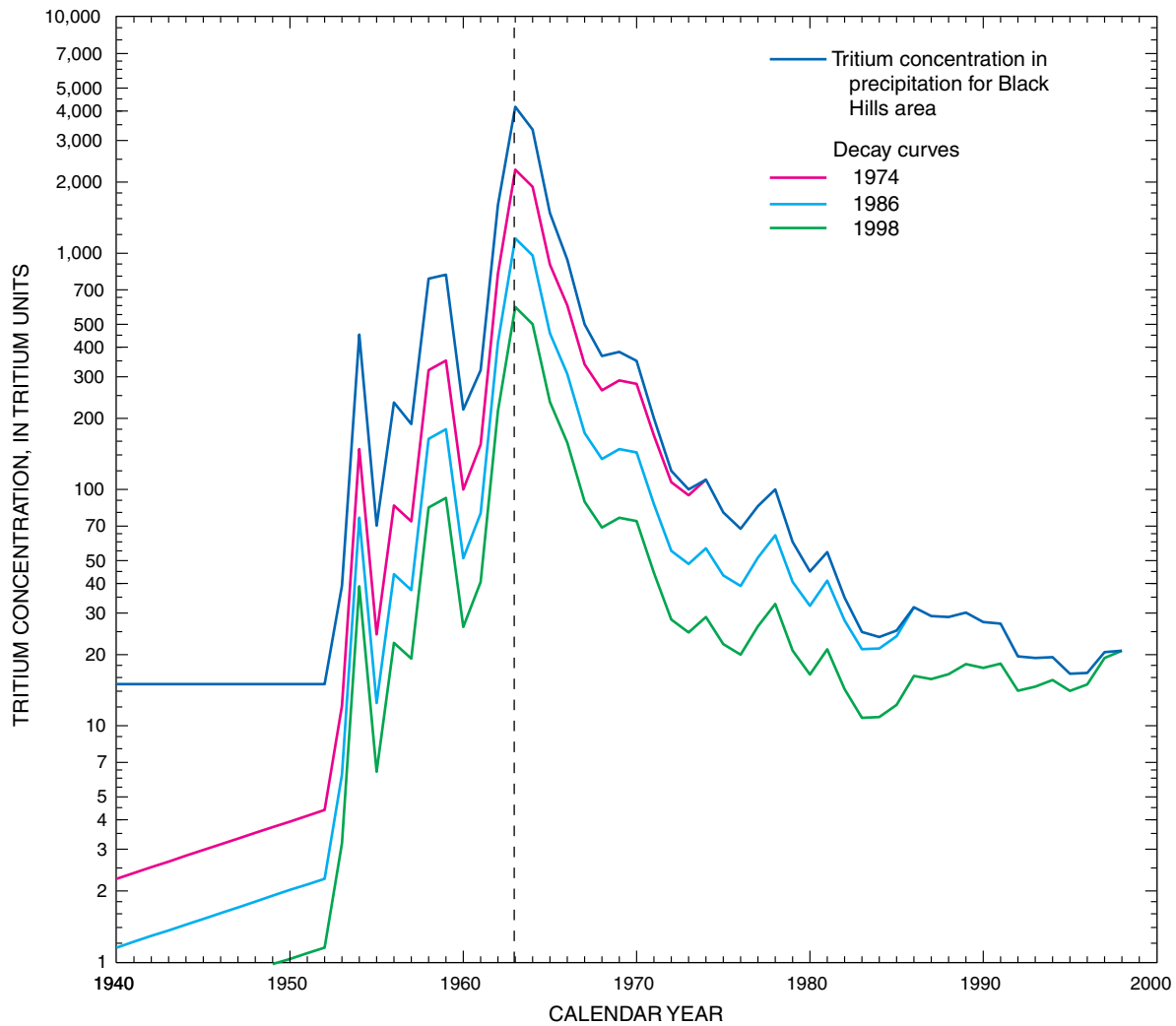
Numerous factors limit capabilities for age-dating of ground-water. One important factor is imprecise data for tritium concentrations in precipitation for the Black Hills area. Estimates by Naus and others (2001) are shown in figure 76, along with decay curves for selected 12-year increments that approximate the half-life decay of tritium. Estimates were derived primarily from data by Michel (1989) that were based on measurements at Ottawa, Canada (fig. 77) and other remote locations. Seasonal variability in tritium concentrations in precipitation (fig. 77) is another limiting factor. The composition of recharge water also can be affected by streamflow recharge, which is inherently older than precipitation. Especially large age differences can occur for streams such as Spearfish Creek or Rapid Creek, where large proportions of flow may originate from discharge of headwater springs.



**Figure 74.** Generalized distribution of  $\delta^{18}\text{O}$  in surface water and ground water in near-recharge areas (from Naus and others, 2001).

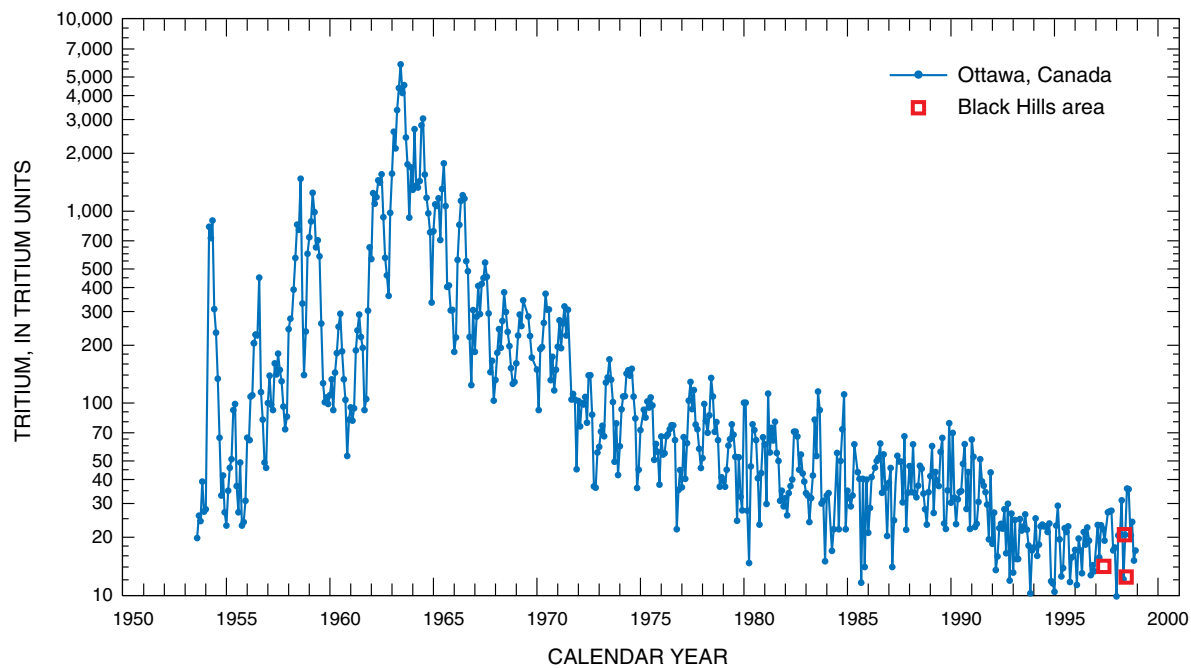


**Figure 75.** Temporal variation of  $\delta^{18}\text{O}$  for selected sites (from Naus and others, 2001). Graph A shows selected loss-zone streams and headwater springs. Graphs B and C show selected wells and artesian springs.



**Figure 76.** Estimated tritium concentrations in precipitation for Black Hills area and decay curves for selected years. Decay curves depict decayed tritium concentrations for selected sampling years. Maximum tritium concentrations of about 4,200 tritium units occurred in about 1963. Tritium has a half-life of about 12.43 years and decay curves are presented for selected 12-year increments that approximate this half-life. Using 1963 as an example, the tritium concentration in a sample collected in 1974 containing water recharged in 1963 would be equal to about 2,200 tritium units. The tritium concentration would have decayed by almost one-half to 1,100 tritium units for a sample collected 12 years later in 1986, and again by about one-half to about 600 tritium units for a sample collected in 1998.





**Figure 77.** Monthly tritium concentrations in precipitation at Ottawa, Canada. Samples collected in Black Hills area of South Dakota also are shown (from Naus and others, 2001).

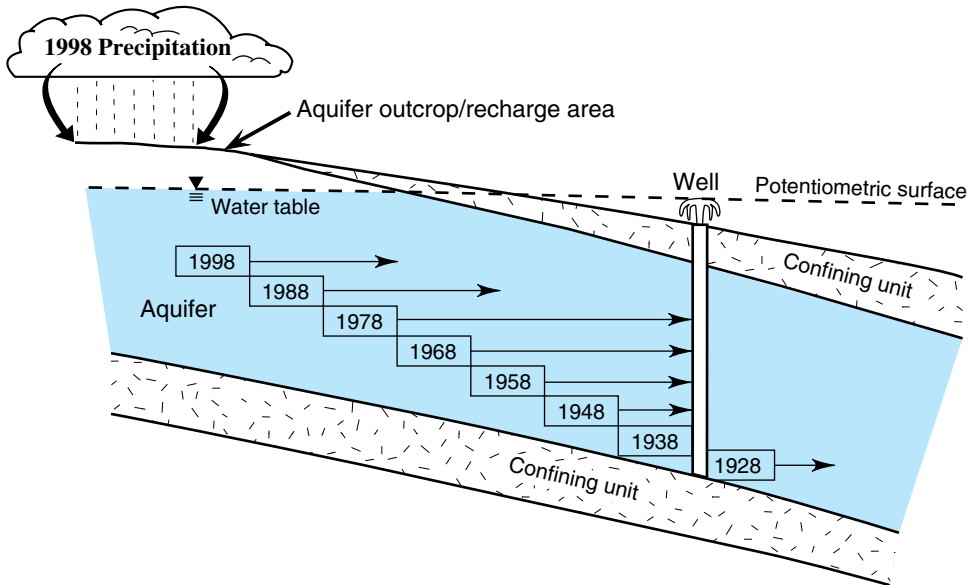
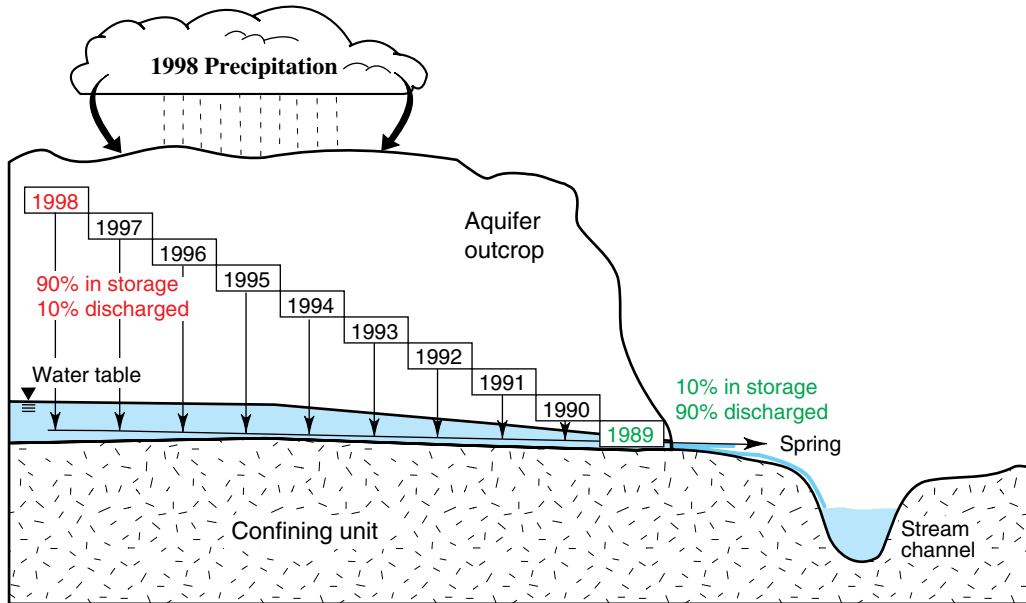
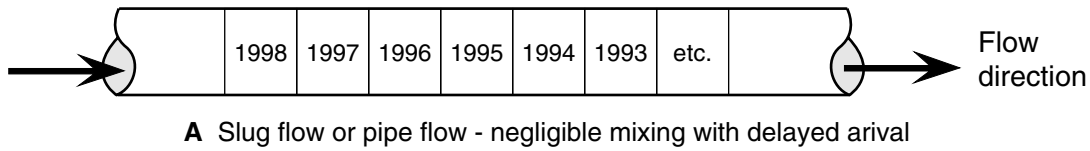
Another important consideration for age dating is ground-water mixing conditions, which can be highly variable because of large heterogeneity within the Madison and Minnelusa aquifers. Naus and others (2001) presented three simplified conceptual mixing models (fig. 78) that were used in evaluating ground-water ages and mixing conditions for the Black Hills area.

The first conceptual model (fig. 78A) depicts slug flow (often termed pipe or piston flow). The decay curves presented in figure 76 would be applicable for slug-flow conditions. For the Madison and Minnelusa aquifers, a slug-flow model could approximate ground-water flow conditions in dual-porosity settings if the dominant flow proportions are in continuous fractures and solution openings, with minimal contributions from the low-porosity matrix, dead-end fractures, or discontinuous solution openings.

The second conceptual model (fig. 78B) depicts the “immediate-arrival” mixing model, which generally is applicable for locations with water-table conditions within outcrop areas, such as headwater springs. For this scenario, water recharged during a given year is mixed with equal proportions of water recharged

during previous years. For the hypothetical spring with a maximum traveltime of about 10 years that is shown in figure 78B, 10 percent of the water recharged during the current year is discharged as springflow during that same year. The remaining 90 percent of the water discharged is composed of equal proportions of water recharged during each of the previous 9 years.

The third conceptual model (fig. 78C) depicts the “time-delay” mixing model, which assumes a delay time before any recharge water reaches a discharge point. This model generally is appropriate where an upper confining unit is present and wells or springs are located some distance from outcrops areas, which is applicable for many locations around the periphery of the Black Hills, especially where confined conditions occur. For example, the hypothetical artesian well shown in figure 78C withdraws a mixture of water that was recharged during a 50-year period from 1929 to 1978. The minimum traveltime (delay time) in this case is 20 years; in other words, the earliest arrival of recharge water is delayed by about 20 years before reaching the discharge point. The maximum traveltime is 70 years.



**Figure 78.** Schematic diagrams illustrating mixing models for age dating for various ground-water flow conditions (from Naus and others, 2001).

The immediate-arrival and time-delay mixing models are based on various assumptions including equal annual recharge from year to year. Routine violation of this assumption (fig. 68) is one limitation for these conceptual models. A larger limitation is the non-homogeneous hydraulic characteristics that commonly occur and result in nonuniform mixing conditions within the Madison and Minnelusa aquifers. Given the large range of hydraulic characteristics, the simplified models cannot address all of the complex mixing and flow conditions that occur. The models do, however, provide a mechanism by which finite numerical age estimates can be derived for water samples.

Decay-curve families for these two mixing models for various sample-collection years were presented by Naus and others (2001). Example curves for a 1995 sample-collection date, which was a midpoint for the main sampling period for the study, are presented in figure 79. The graph includes a family of curves depicting minimum traveltimes, or delay times, in 4-year increments. The 0-year delay curve in figure 79 is applicable for the immediate-arrival mixing model (fig. 78B), and the other curves are applicable for the time-delay mixing model (fig. 78C).

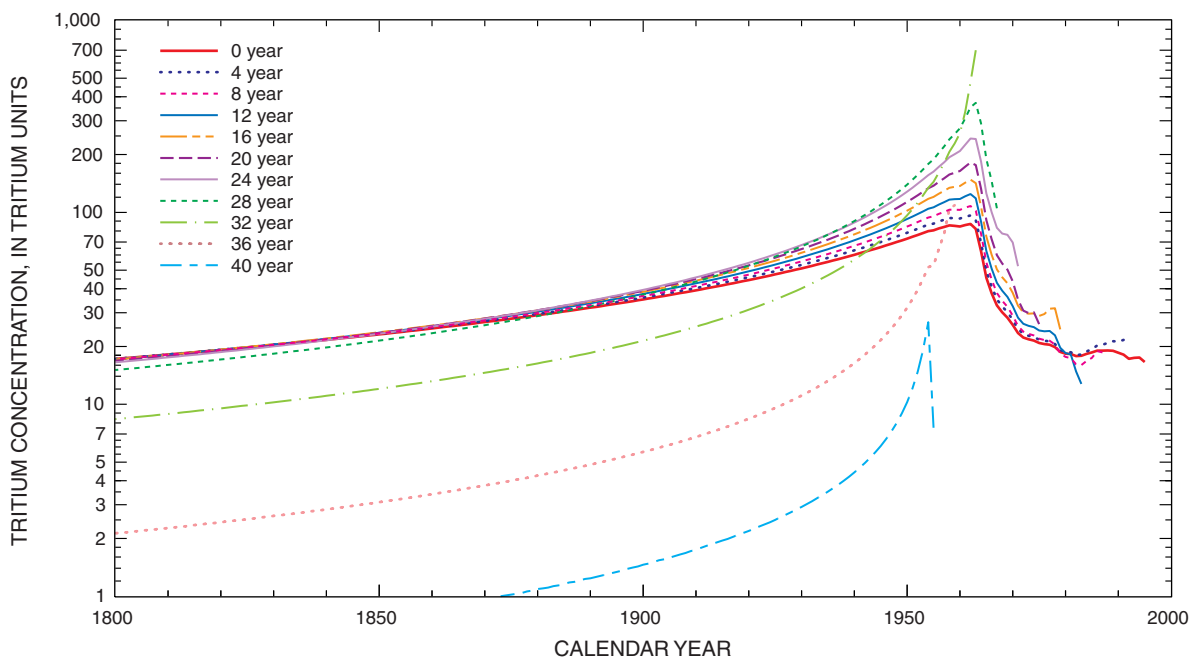
Using a sample concentration of 50 TU as an example, the immediate-arrival model (0-year delay

curve) indicates two possible solutions, including equal annual recharge during about 1964-95 or 1930-95 (fig. 79). Two solutions also are possible for time-delay scenarios with delay times less than about 24 years. Using the 20-year delay curve for the same example, the concentration would indicate recharge during about 1969-75 or 1915-75. Because multiple solutions are possible for most sample concentrations, two or more samples usually are necessary for making general estimations of ground-water age.

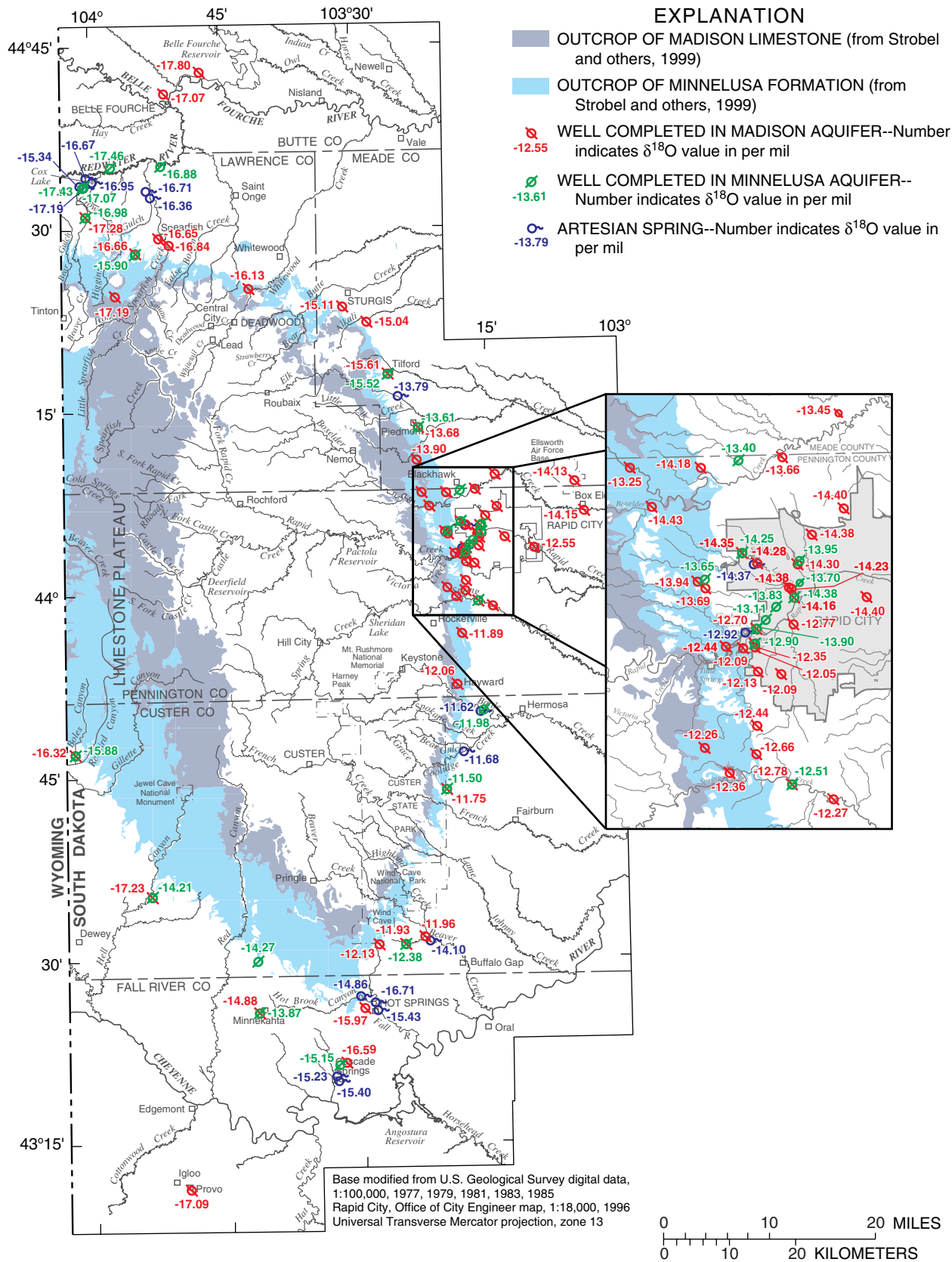
### Isotope Distributions and General Considerations

Distributions for  $\delta^{18}\text{O}$  and tritium are presented in this section. Various general considerations associated with the isotope distributions also are discussed.

Distributions of  $\delta^{18}\text{O}$  values in Madison and Minnelusa wells and selected springs are shown in figure 80. Samples from sites considered representative of the isotopic composition of recharge in the study area were presented earlier in figure 74 and are excluded from figure 80. Distributions of stable isotopes generally are consistent with spatial patterns in recharge areas (fig. 74), with isotopically lighter precipitation generally occurring at higher altitudes and latitudes.



**Figure 79.** Decay-curve family for delayed-arrival mixing model for a 1995 sampling date (from Naus and others, 2001). Each curve shows average decayed tritium concentrations, for hypothetical mixes over time, for specified delay times that are provided in 4-year increments.



**Figure 80.** Distribution of  $\delta^{18}\text{O}$  in samples from selected Madison and Minnelusa wells and springs in the Black Hills area (modified from Naus and others, 2001). Sampling dates are through 1998, with mean values shown for sites with multiple samples.

The effects of recharge altitude are apparent in some areas. The  $\delta^{18}\text{O}$  values are lighter in the Madison aquifer than in the Minnelusa aquifer for 10 of 13 well pairs shown in figure 80 because the Madison aquifer generally is recharged at a higher altitude than the Minnelusa aquifer. The Madison aquifer also is influenced by preferentially larger volumes of isotopically light streamflow recharge, relative to the Minnelusa aquifer.

The  $\delta^{18}\text{O}$  values for samples from a Madison/Minnelusa well pair at Tilford (fig. 80) are somewhat lighter than in nearby outcrop areas (fig. 74) and are distinctively lighter than for samples from a Madison/Minnelusa well pair at Piedmont and for the artesian spring between Tilford and Piedmont. The spring and the Piedmont wells probably are influenced predominantly by recharge on nearby outcrops, whereas the Tilford wells probably are influenced predominantly by streamflow recharge from Elk Creek.

In the southern Black Hills, the  $\delta^{18}\text{O}$  values for samples from sites near Battle, Grace Coolidge, and French Creeks (fig. 80) are isotopically heavier than for any other part of the Black Hills area and are similar to values for nearby streamflow loss zones (fig. 74). Along the southern and southwestern flanks of the uplift,  $\delta^{18}\text{O}$  values for samples from most wells and springs (fig. 80) are much lighter than estimated values for near-recharge areas immediately nearby (fig. 74), indicating either recharge areas to the northwest or possible influence of regional flow from the west, as discussed in subsequent sections of this report.

Distributions of tritium in Madison and Minnelusa wells and selected springs are shown in figure 81. Large spatial variability in concentrations occurs near outcrop areas, which reflects large variability in mixing conditions and aquifer characteristics (heterogeneity). Most samples from wells that are far removed from outcrop areas have low, or nondetectable (<0.3 TU) tritium concentrations. Concentrations noted as <0.3 TU are equivalent to about <1.0 pCi/L, which is the method reporting limit (MRL) for most of the laboratory analyses that have been performed. Samples reported as <0.3 TU are assumed to be composed primarily of water recharged prior to initial influence of nuclear testing during the early 1950's (pre-bomb water), regardless of mixing conditions (Naus and others, 2001).

Samples with tritium concentrations that equal or slightly exceed the MRL also are dominated by pre-bomb water, but probably are showing the presence of some proportion of modern water (recharged since the

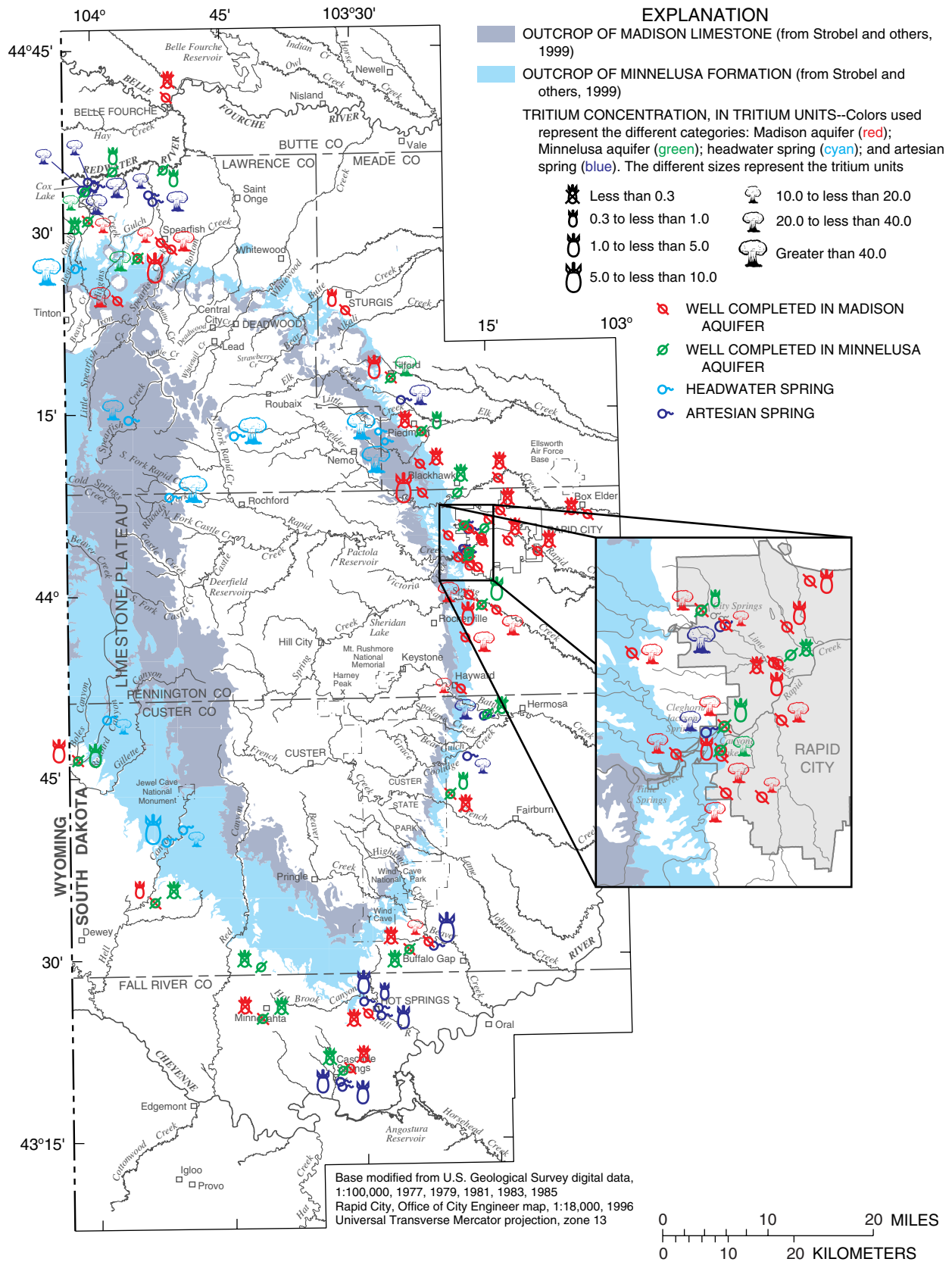
early 1950's). For concentrations between 0.3 and 1.0 TU, the detection of modern water is fairly certain, from an analytical standpoint, and would indicate either: (1) the initial arrival of modern water for slug-flow conditions; or (2) at least some proportion of modern water for all mixing conditions.

Given the uncertainty in estimation of tritium concentrations in recent precipitation (since about 1992) for the Black Hills area, concentrations as low as 10 TU (fig. 76) may be possible for recently recharged water. Thus, for samples with tritium concentrations between about 1 and 5 TU, dominant proportions of pre-bomb water generally can be assumed. For concentrations greater than about 5 TU, it is difficult to make generalizations because of numerous possible mixing scenarios; however, for all mixing conditions, the probability of dominant proportions of modern water increases with increasing tritium concentrations.

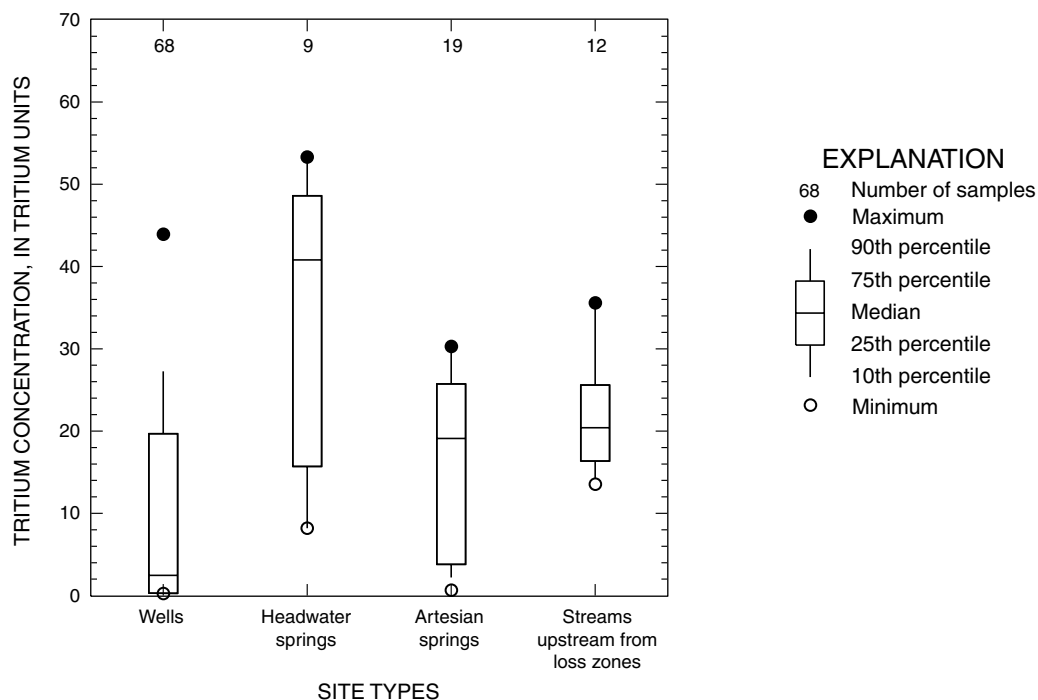
Boxplots showing the distribution of tritium in samples collected during 1990-98 from wells, headwater springs, artesian springs, and streams upstream from loss zones in the Black Hills area are presented in figure 82. Concentrations for samples from streams upstream of loss zones generally are comparable with estimated concentrations for precipitation in the Black Hills area since about 1985 (fig. 76). As a group, headwater springs have the highest tritium concentrations, which generally indicates relatively large proportions of modern water. Potential age ranges for selected headwater springs were estimated by Naus and others (2001) using the immediate-arrival mixing model. Concentrations for samples generally are lower from wells than artesian springs, which probably tend to develop near preferential flowpaths that may be further enhanced by dissolution activity and thus are associated with relatively faster traveltimes than flowpaths to wells.

Tritium distributions for the ground-water sites (fig. 82) provide evidence that the mixing models illustrated in figure 78 have general applicability. The lower end of the range of tritium concentrations for headwater springs is much higher than for the wells and artesian springs, which is consistent with the concept of an immediate-arrival mixing model in outcrop areas for the Madison and Minnelusa aquifers. The lower end of the range of concentrations for wells and artesian springs is near zero, which supports applicability of the time-delay model in areas where an upper confining layer is present.





**Figure 81.** Tritium occurrence for selected sample sites in Black Hills area (modified from Naus and others, 2001). Sites considered include only those sampled during the 1990's with the most recent concentration shown for sites with multiple samples. Higher tritium concentrations indicate larger proportions of modern water.



**Figure 82.** Boxplots of tritium concentrations for selected ground-water and surface-water samples collected during 1980-98 in the Black Hills area (from Naus and others, 2001).

The tritium distributions also provide evidence that purely slug-flow conditions probably are uncommon within the Madison and Minnelusa aquifers. For slug-flow conditions, water recharged between about 1962 and 1970 would have tritium concentrations of about 70 TU to as much as several hundred TU for all sample dates prior to 1998 (fig. 76). Tritium concentrations for the 96 ground-water samples collected since 1990, however, are uniformly less than 70 TU (fig. 82).

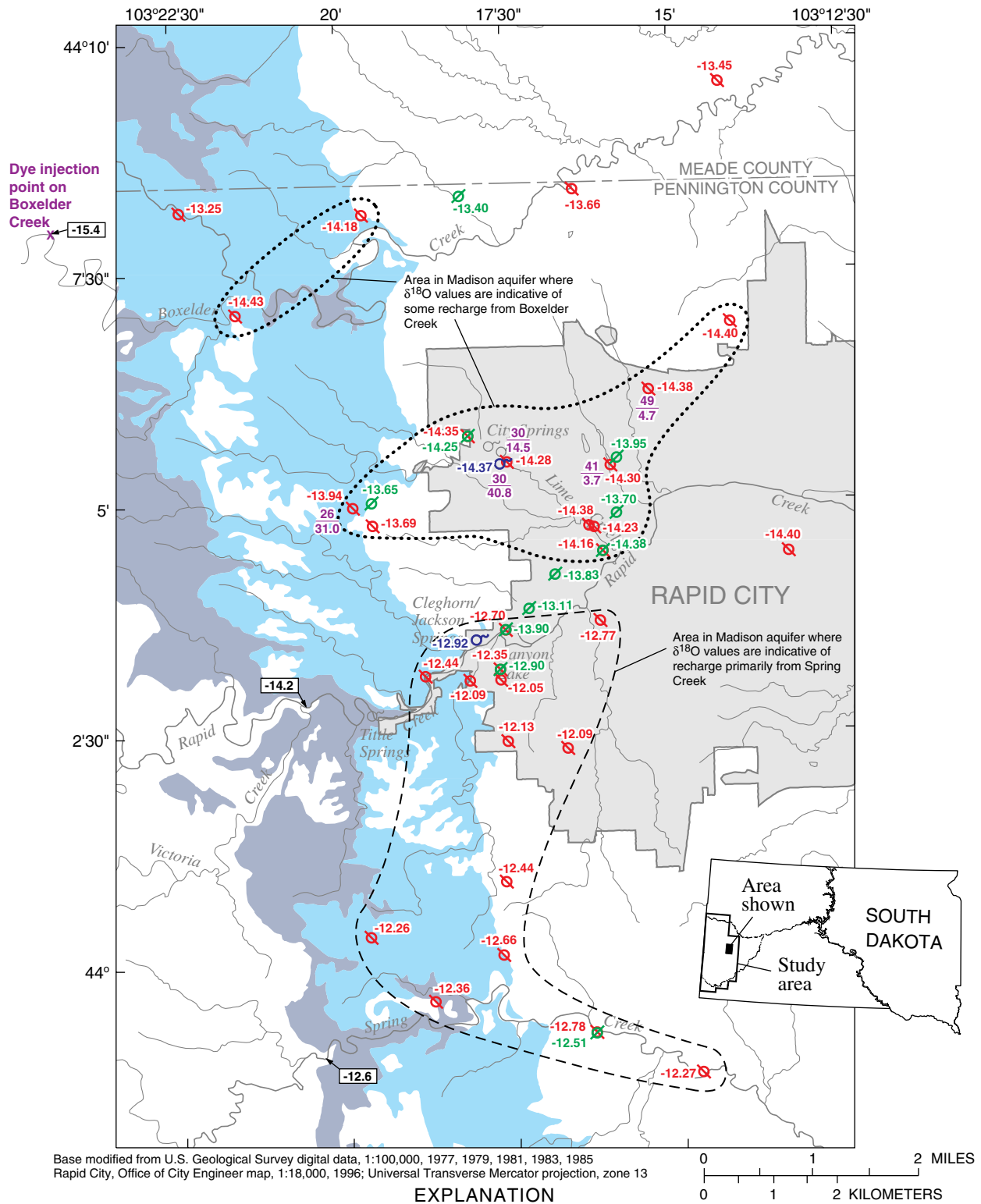
### Flowpaths, Ages, and Mixing Conditions

A summary of interpretations regarding flowpaths, ages, and mixing conditions for the Madison and Minnelusa aquifers is presented in this section. Discussions include the Rapid City area and the northern and southern Black Hills. Regional flowpath considerations are included in discussions of the northern and southern Black Hills.

### Rapid City Area

Extensive data sets of isotope information are available for the Rapid City area. In addition, dye testing in this area has provided useful information regarding flowpaths, relative ages of ground water, and mixing conditions. Evaluation of flowpaths and mixing conditions for the Rapid City area is especially complicated because: (1) recharge generally is dominated by streamflow losses, rather than precipitation on outcrop areas (Carter, Driscoll, and Hamade, 2001); and (2) large and variable withdrawals from the Madison and Minnelusa aquifers have occurred. Municipal production from the Madison aquifer has increased substantially since about 1990 (Anderson and others, 1999).

Dye testing has consisted of dye injection at a swallow hole in the loss zone of Boxelder Creek, with dye recovery documented at locations indicated in figure 83, many of which are located in the Rapid Creek drainage basin. The time required (in days) for the earliest arrival of dye from the dye injection point on Boxelder Creek to reach the various locations is shown in figure 83.



**Figure 83.** Concentrations of  $\delta^{18}\text{O}$  in Madison and Minnelusa aquifers in Rapid City area (modified from Naus and others, 2001). Average  $\delta^{18}\text{O}$  values for streamflow loss zones also are shown. In addition, traveltimes and tritium concentrations for sites at which dye recovery was reported by Greene (1999) are shown.



A distinct division of stable isotope values is apparent for the Madison aquifer along Rapid Creek (fig. 83). Areas south of Rapid Creek reflect isotopic composition similar to Spring Creek (fig. 83), which is isotopically heavier than Rapid Creek and Boxelder Creek (fig. 75). Sites north of Rapid Creek generally reflect isotopically lighter composition similar to that of Rapid Creek and Boxelder Creek, indicating a combination of recharge from these areas. Areas that probably have some influence from water recharged in Boxelder Creek also are shown in figure 83. The  $\delta^{18}\text{O}$  values for samples from Minnelusa wells in the Rapid City area show a general gradation from north to south of lighter to heavier values, with no distinct division, which probably indicates larger influence from precipitation recharge, than for the Madison aquifer in this area.

Results of 1993 dye testing in the Rapid City area (Greene, 1999), in combination with tritium samples, provide relatively definitive age-dating information for several sites. A tritium concentration of 58.1 TU was measured at the dye-injection location along Boxelder Creek. Two of the wells with dye recovery (within less than 50 days of injection) had detectable, but low, tritium values (3.7 and 4.7 TU; fig. 83), which generally would be considered indicative of large proportions of pre-bomb water. This inference is reasonable, but somewhat misleading because the small proportions of modern water in the mix consist of extremely modern water. Unequal mixing of about 5 to 10 percent very recent water (tritium concentration of about 58 TU) with 90 to 95 percent pre-bomb water (0 TU) was suggested by Naus and others (2001) as a viable mix for these sites. This scenario is a noteworthy example of unequal mixing conditions that can occur in a dual-porosity system.

Time-series  $\delta^{18}\text{O}$  and tritium data provide useful information regarding mixing conditions and general ages for numerous other sampling sites in the Rapid City area. Sites with minimal variability in  $\delta^{18}\text{O}$  values generally have tritium data indicative of dominant proportions of pre-bomb water, reflecting generally thorough mixing conditions. A number of sites, however, showed response to temporal  $\delta^{18}\text{O}$  trends in stream-flow recharge (fig. 75), with associated tritium data generally indicating relatively large proportions of modern recharge. Water from several large Madison production wells located along Rapid Creek had changes in  $\delta^{18}\text{O}$  values indicative of changes in capture zones associated with recent production. Potential

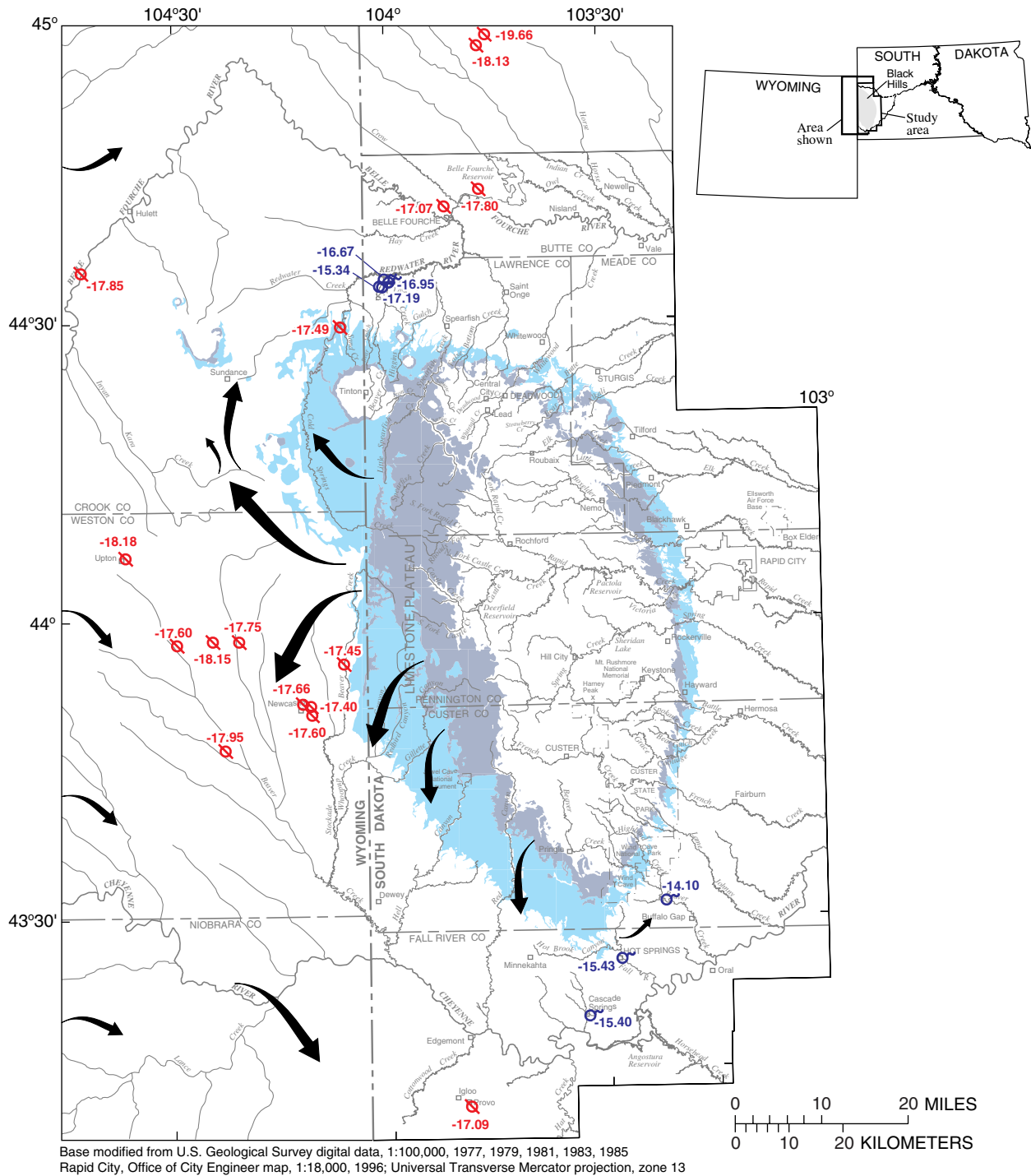
changes in ground-water age characteristics at several wells also were indicated by tritium concentrations for sequential samples.

### Northern Black Hills

Naus and others (2001) examined the possible influence of regional flow components from the west for the Madison aquifer in the northern part of the study area. Samples from two Madison wells just north of the study area (fig. 84) show influence of regional flow, with  $\delta^{18}\text{O}$  values (-18.13 ‰ and -19.66 ‰) that are much lighter than any of the values in the Black Hills recharge areas (fig. 74). Busby and others (1983) and Plummer and others (1990) noted samples from Madison wells near recharge areas in Wyoming near the Bighorn Mountains with  $\delta^{18}\text{O}$  values as light as -18.5 ‰ and near the Laramie Mountains as light as -19.25 ‰. Concentrations of common ions for samples from the two wells just north of the study area (Busby and others, 1991) are approximately an order of magnitude higher than for samples from wells along the northwestern flank of the Black Hills and are consistent with a regional flowpath trending northeasterly from the Bighorn Mountains in Wyoming (fig. 17).

The  $\delta^{18}\text{O}$  value of -17.80 ‰ for a well sample northeast of Belle Fourche (fig. 84) indicates possible minor influence from regional flow; however, the value of -17.07 ‰ for the well sample at Belle Fourche provides no indication of regional influence. Ion concentrations for the well sample northeast of Belle Fourche are slightly higher than for the well sample at Belle Fourche (fig. 34), but are much lower than concentrations for samples from the two wells just north of the study area (Busby and others, 1991). Ion concentrations also are low for a sample from a well just north of Nisland (fig. 34). Thus, Naus and others (2001) concluded that regional flowpaths in the Madison aquifer are largely deflected to the north of the study area. Regional  $\delta^{18}\text{O}$  values are not available for the Minnelusa aquifer; however, values for Minnelusa wells along the northwestern flank of the uplift (fig. 84) are similar to those in near-recharge areas to the south and west (fig. 74).

Several large artesian springs located along the northern axis of the uplift are a major hydrologic feature of the northern Black Hills area. These springs are a major discharge area for the Madison and Minnelusa aquifers (Klemp, 1995), with cumulative discharge of all artesian springs along the northern flank estimated as 90 ft<sup>3</sup>/s for 1987-96 (Carter, Driscoll, Hamade, and



**EXPLANATION**

- OUTCROP OF MADISON LIMESTONE (from Strobel and others, 1999; DeWitt and others, 1989)
- OUTCROP OF MINNELUSA FORMATION (from Strobel and others, 1999; DeWitt and others, 1989)
- GENERALIZED FLOWPATH
- ⊗ WELL COMPLETED IN MADISON AQUIFER-- Number indicates  $\delta^{18}\text{O}$  value in per mil
- ⊕ ARTESIAN SPRING--Number indicates  $\delta^{18}\text{O}$  value in per mil

**Figure 84.** Distribution of  $\delta^{18}\text{O}$  in selected Madison wells and springs and generalized flowpaths, based on  $\delta^{18}\text{O}$  values, in the Black Hills of South Dakota and Wyoming (from Naus and others, 2001).

Jarrell, 2001). The  $\delta^{18}\text{O}$  values (fig. 80) and tritium concentrations (fig. 81) for most of these springs are quite similar, which probably indicates generally thorough mixing conditions resulting from large discharges (and associated large recharge areas). The tritium concentrations are consistently indicative of modern recharge, which does not necessarily preclude regional flow contributions, but confirms Black Hills recharge as the primary recharge component. Multiple tritium samples are available for several springs and wells along the northern flank of the uplift. General evaluations of potential age ranges derived using the time-delay mixing model were discussed by Naus and others (2001).

Results of water-budget analyses for the Madison and Minnelusa aquifers (figs. 69 and 70, table 15) support the geochemical interpretation of minimal influence from regional flowpaths in the northern part of the study area. For subarea 1, which includes the large artesian spring area along the northern axis, ground-water outflow is estimated to exceed inflow by about  $30 \text{ ft}^3/\text{s}$ . This analysis does not necessarily preclude a regional ground-water flow component in the northern part of the study area, but does support the conclusion of dominance by recharge in the Black Hills area.

### **Southern Black Hills**

Naus and others (2001) also evaluated the possible influence of regional flow components for the Madison aquifer in the southern part of the study area. Light  $\delta^{18}\text{O}$  values from samples for several sites west of the study area in Weston County (fig. 84) are indicative of a possible transition zone between regional and areal flowpaths. Ion concentrations for samples from wells in this area (Busby and others, 1991) generally showed little, if any, influence of regional flow, however. High ion concentrations for samples from several Madison wells in the southwestern corner of the study area (fig. 34) indicate possible regional influence, but cannot necessarily be distinguished from basinward increases in constituent concentrations. Farther north, regional influence probably is minor or negligible.

Several large artesian springs located along the southern axis of the Black Hills uplift comprise another major discharge area for the Madison and Minnelusa aquifers (Whalen, 1994; Hayes, 1999). For subareas 7 and 8 (figs. 69 and 70), artesian spring discharge averaged about  $54 \text{ ft}^3/\text{s}$  during 1987-96 (table 15). Combined streamflow and precipitation recharge for these subareas averaged only about  $14 \text{ ft}^3/\text{s}$ ; thus, much of

the recharge for the springs probably occurs in subarea 9, where recharge averaged about  $60 \text{ ft}^3/\text{s}$ . Considering the three subareas (7, 8, and 9) collectively, ground-water outflow is estimated to exceed inflow by about  $7 \text{ ft}^3/\text{s}$ . This analysis does not necessarily preclude a regional ground-water flow component in the southern part of the study area, but does indicate dominance by recharge in the Black Hills area.

Dominance by recharge in the Black Hills area also is indicated by the  $\delta^{18}\text{O}$  values for the large springs (fig. 84), which are notably heavier than reported regional values (Busby and others, 1983; Plummer and others, 1990) and essentially preclude substantial influence from regional flowpaths. This conclusion is supported by ion concentrations for the springs (fig. 34 and 35), which are insufficient to be indicative of regional flow. High sulfate concentrations for several of the springs reflect influence from dissolution of anhydrite within the Minnelusa Formation.

Low, but detectable, tritium concentrations in the large springs (fig. 81) confirm the influence of recharge from within the study area, but indicate relatively long travel times. This is consistent with the  $\delta^{18}\text{O}$  values, which indicate potential recharge areas extending along the entire southwestern flank of the uplift. Generally low tritium concentrations for large springs in the southern Black Hills, relative to concentrations for springs along the northern axis, may be influenced by generally smaller recharge rates in the southern Black Hills.

The  $\delta^{18}\text{O}$  value for Beaver Creek Spring ( $-14.10 \text{ ‰}$ ; figs. 80 and 84) located just northwest of Buffalo Gap is much lighter than estimated values for nearby outcrop areas and samples from nearby wells, which indicates a possible flowpath extending from the general Hot Springs area. This interpretation also is supported by a low tritium value for Beaver Creek Spring (fig. 81), which indicates generally long travel times, and by the water-budget analysis, which indicates a substantial flow component to the spring from west of the uplift axis (figs. 69 and 70, table 15).

Tritium concentrations for artesian springs along Battle and Grace Coolidge Creeks indicate younger water than for several nearby wells (fig. 81), which is consistent with development of artesian springs along preferential flowpaths. The discharges of these springs (which are located in subarea 5) are highly variable (table 15), and probably are influenced primarily by variability in streamflow recharge, which dominates recharge in this subarea.

## Interactions Between Aquifers

Geologic conditions facilitate hydraulic connection between the Madison and Minnelusa aquifers. Confining layers in the lower portion of the Minnelusa Formation probably are influenced by paleokarst features such as caverns and sinkholes in the upper Madison Limestone. Extensive fracturing and solution activity have contributed to enhanced secondary porosity in both formations and decreased competency of the confining layers. Potential exists for downward leakage (from Minnelusa to Madison) in recharge areas where the aquifers are unconfined (water-table conditions), and for either upward or downward leakage, depending on direction of hydraulic gradient, where confined conditions exist. Hydraulic connections probably occur at various artesian springs, many of which discharge stratigraphically within or slightly above the Minnelusa Formation, but may include the Madison aquifer as a source (Whalen, 1994; Klemp, 1995; Hayes, 1999). Naus and others (2001) evaluated potential interactions through analysis of hydraulic and geochemical information for well pairs and artesian springs.

Hydrographs for Madison and Minnelusa well pairs were presented previously in figs. 26-29 and potential interactions were discussed in the section "Comparisons between Madison and Minnelusa aquifers." Hydraulic connection for most colocated wells cannot be confirmed or refuted because aquifer testing has not been performed. Of the well pairs with generally similar hydrographs (fig. 27), hydraulic connection has been confirmed by aquifer testing (Greene, 1993) only for the City Quarry wells (fig. 27D). These wells are located near City Springs, where aquifer connection has been confirmed by dye testing (Greene, 1999). Aquifer testing (Greene and others, 1999) provided no indication of hydraulic connection in the vicinity of the Spearfish Golf Course wells (fig. 27A). Hydrographs for many other colocated wells indicate distinct hydraulic separation and no evidence of direct hydraulic connection between the aquifers.

Although some exchange of water must occur in locations where hydraulic head differences occur, Naus and others (2001) concluded from examination of geochemical information for colocated wells that general leakage between the Madison and Minnelusa aquifers probably does not result in areally extensive mixing in most locations. The most notable differences in ion chemistry (figs. 34 and 35) are in concentrations

of sulfate, which increase with increasing distance from recharge areas in the Minnelusa aquifer but do not provide definitive information regarding aquifer mixing. Although  $\delta^{18}\text{O}$  values for samples from colocated Madison and Minnelusa wells (fig. 80) reflect generally higher recharge altitudes for the Madison aquifer than for the Minnelusa aquifer, information regarding aquifer mixing is inconclusive. Similarly, tritium concentrations for well pairs (fig. 81) do not provide conclusive information.

Substantial interactions between the Madison and Minnelusa aquifers can occur at artesian springs, many of which have large discharges. Combined discharge of all artesian springs within the Black Hills area of South Dakota and Wyoming was estimated by Driscoll and Carter (2001) as  $169 \text{ ft}^3/\text{s}$  for 1950-98, which represents about 46 percent of average recharge to both aquifers (table 14). Numerous investigators have identified the Madison and Minnelusa aquifers as probable sources for artesian springs in the Black Hills, based on hydraulic properties and geochemical characteristics. The Minnekahta aquifer also may be a contributing source in locations where the Minnekahta Limestone is present. The underlying Deadwood aquifer also cannot be discounted as a possible source.

Locations of artesian springs are shown on the previously presented potentiometric-surface maps of the Madison and Minnelusa aquifers (figs. 19 and 20). Hydraulic heads in these aquifers at major spring locations were estimated from potentiometric-surface maps and are summarized in table 18, along with the approximate land-surface altitudes near the springs.

Several hydraulic possibilities exist for interactions between the Madison and Minnelusa aquifers at spring locations, including: (1) water originates only from the Minnelusa aquifer, with no contribution from the underlying Madison aquifer; (2) water originates entirely from the Madison aquifer and passes through the Minnelusa Formation, with little interaction; (3) water originates entirely from the Madison aquifer, part of which discharges at the surface and part of which recharges the Minnelusa aquifer; and (4) water originating from both aquifers contributes to springflow. For cases where the Madison aquifer contributes to springflow, leakage to the Minnelusa aquifer could consist of either focused leakage in the immediate vicinity of the spring-discharge point or general leakage in upgradient locations.

**Table 18.** Selected hydraulic and geochemical information for major artesian springs[Modified from Naus and others (2001). ft<sup>3</sup>/s, cubic feet per second; mg/L, milligrams per liter; <, less than; ≈, approximately equal]

Name	Approximate discharge (ft <sup>3</sup> /s)	Altitude of land surface (feet above sea level)	Hydraulic head (feet above sea level)		Sulfate (mg/L)	Estimated spring source from previous studies
			Madison aquifer	Minnelusa aquifer		
Higgins Gulch	5-10	3,405	3,490	3,550	110	Mostly Madison <sup>1</sup>
Old Spearfish Hatchery	≈5	3,405	3,500	3,550	340	70 percent Madison, 30 percent Minnelusa <sup>1</sup>
NcNenny Rearing Pond	≈1	3,400	3,720	3,580	130	Mostly Madison <sup>1</sup>
Mirror Lake	≈1	3,410	3,720	3,580	1,600	50 percent Madison, 50 percent Minnelusa <sup>1</sup>
Cox Lake	≈5	3,415	3,705	3,580	545	Mostly Madison <sup>1</sup>
Crow Creek	30-50	3,355	3,710	3,560	580	--
Elk Creek	0-20	3,450	3,450	3,450	420	--
City Springs	0-5	3,440	3,450	3,450	98	--
Cleghorn Springs	20-25	3,380	3,420	3,380	25	--
Battle Creek	1-10	3,540	3,540	3,540	19	--
Grace Coolidge Creek	0-20	3,650	3,650	3,650	11	--
Beaver Creek Spring	10-15	3,460	3,480	3,480	1,300	Mostly Madison with dissolved Minnelusa minerals <sup>2</sup>
Hot Brook Spring	<5	3,625	3,700	3,625	76	Mostly Madison <sup>2</sup>
Evans Plunge Spring	<5	3,465	3,610	3,420	540	Mostly Madison <sup>2</sup>
Fall River	20-30	3,415	3,580	3,360	400	--
Cool Spring	≈2	3,450	3,505	3,450	830	--
Cascade Spring	18-22	3,440	3,495	3,450	1,500	Mostly Madison with dissolved Minnelusa minerals <sup>3</sup>

<sup>1</sup>Estimated by Klemp (1995).<sup>2</sup>Estimated by Whalen (1994).<sup>3</sup>Estimated by Hayes (1999).

Precise quantification of relative contributions from source aquifers to individual springs is not necessarily possible; however, the Minnelusa aquifer probably can be discounted as a primary source for springs located where the Minnelusa Formation is exposed, which generally precludes confined conditions in the Minnelusa aquifer. This setting exists at Cleghorn/Jackson Springs in western Rapid City and at Hot Brook Spring located just northwest of Hot Springs (fig. 20). Other artesian springs listed in table 18 occur in locations where the Minnelusa Formation is confined by overlying units and confined conditions are assumed for both the Madison and Minnelusa aquifers. Mapped hydraulic heads at most artesian spring

locations are higher in the Madison aquifer than the Minnelusa aquifer (table 18, figs. 19 and 20), which could indicate higher potential for contributions to springflow from the Madison aquifer, relative to contributions from the Minnelusa aquifer. An alternative line of reasoning may be plausible, however. Higher hydraulic head in the Madison aquifer also indicates relatively competent confinement by the overlying Minnelusa Formation, which could imply larger contributions from the Minnelusa aquifer. Thus, generalities regarding dominant contributions to artesian springflow cannot be inferred from comparisons of hydraulic head.

Discharge characteristics for artesian springs (table 18) probably are affected by hydraulic conditions at spring locations. Flow variability is minimal for many artesian springs (Miller and Driscoll, 1998; Anderson and others, 1999; U.S. Geological Survey, 2000), including McNenny Rearing Pond, Cox Lake, Crow Creek, Cleghorn Springs, Beaver Creek Springs, Fall River, and Cascade Springs. Hydraulic heads at these sites generally are substantially above land surface for one or both of the two aquifers. In contrast, discharge is much more variable for Elk Creek, City Springs, Battle Creek, and Grace Coolidge Creek. At these sites, mapped hydraulic heads in both aquifers are approximately coincident with land-surface altitude.

Contributions from the Madison and Minnelusa aquifers to individual artesian springs cannot necessarily be quantified precisely (Naus and others, 2001) because of geochemical similarities between the aquifers (figs. 35 and 36). For some springs, high sulfate concentrations (table 18) could indicate Minnelusa influence, but may result from dissolution of Minnelusa minerals by water from the Madison aquifer. Previous investigators (Whalen, 1994; Klemp, 1995; and Hayes, 1999) used geochemical modeling to estimate contributions of the Madison and Minnelusa aquifers to selected springs; generalized results are summarized in table 18. The Madison aquifer generally was identified as the primary source, with variable contributions from the Minnelusa aquifer, or chemical influences resulting from residence time within the Minnelusa Formation.

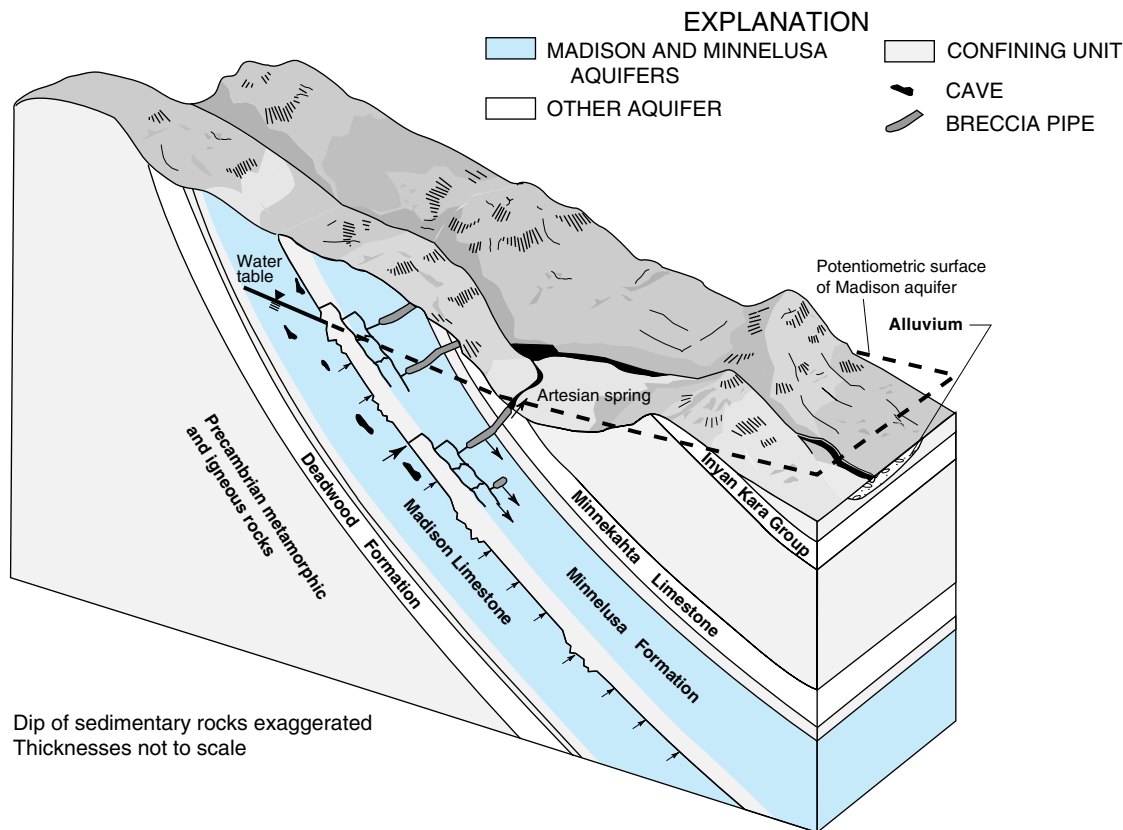
Saturation indices reported by Naus and others (2001) indicate that the Madison aquifer is undersaturated with respect to gypsum, even at the highest sulfate concentrations. Generally higher hydraulic head in the Madison aquifer, in combination with gypsum undersaturation, was concluded by Naus and others (2001) to be a primary mechanism driving interactions with the Minnelusa aquifer, in areas where confined conditions exist. Upward leakage from the Madison aquifer probably contributes to general dissolution of anhydrite deposits and development of breccia pipes in the Minnelusa aquifer. Breccia development may be especially prevalent in locations where the competency of intervening confining layers has been decreased by fracturing or by depositional influences in the Minnelusa Formation resulting from paleokarstification of the Madison Limestone.

Hayes (1999) hypothesized that upward leakage from the Madison aquifer was contributing to ongoing development of breccia pipes at Cascade Springs. Hayes (1999) noted that breccia pipes commonly occur in the upper Minnelusa Formation, but very few have been observed in the lower part of the formation. Networks of interbedded breccia layers and short, vertical breccia dikes do occur in the lower Minnelusa Formation, however, as schematically illustrated in figure 85.

Development of breccia pipes probably contributes to enhanced vertical hydraulic conductivity in the Minnelusa aquifer. Breccia pipes are a likely pathway for upward movement of large quantities of water through the Minnelusa aquifer at artesian spring locations. Dissolution processes are an important factor in a self-perpetuating process associated with development of preferential flowpaths and artesian springs. Preferential flowpaths initially develop in locations with large secondary porosity and associated hydraulic conductivity, with ongoing enhancement resulting from dissolution activity.

Hayes (1999) further hypothesized that many exposed breccia pipes of the upper Minnelusa Formation probably are the throats of abandoned artesian springs. An outward (downgradient) shifting of locations of artesian springs probably has occurred as upgradient spring-discharge points are abandoned and new ones are occupied, keeping pace with regional erosion over geologic time (Hayes, 1999). In response, hydraulic heads in the Madison and Minnelusa aquifers have declined over geologic time, as indicated by exposed breccia pipes located upgradient from Cascade Springs (Hayes, 1999). Further supporting evidence is provided by Ford and others (1993), who concluded that water-level declines of more than 300 ft have occurred in the Madison aquifer during the last 350,000 years, based on geochemical data for Wind Cave.

Ground water discharging from the Madison aquifer at artesian springs was referred to as "rejected recharge" by Huntoon (1985), who hypothesized that recharge is rejected as transmissivity decreases with distance from upgradient recharge areas. This hypothesis is consistent with decreasing potential for large secondary porosity with increasing distance from the uplift, which results from: (1) decreased deformation and associated fracturing of rocks; and (2) decreasing potential for dissolution enhancement associated with increasing basinward concentrations of dissolved constituents.



**Figure 85.** Schematic showing breccia pipes and caves in relation to the hydrogeologic setting of the Black Hills area (modified from Hayes, 1999). Breccia pipes contribute to secondary porosity in the Madison and Minnelusa aquifers and may result from upward leakage from the Madison aquifer, creating conduits for artesian springs. Arrows show general areal leakage and focused leakage at breccia pipes.

Artesian springs are essentially a “pressure-relief” mechanism that influence the upper limit for hydraulic head. As previously noted, springs located where hydraulic head is substantially above land surface generally have relatively stable discharge. In locations where hydraulic head is near land surface, however, discharge characteristics generally are more variable, with springflow increasing in response to increasing water levels.

Considering all available information, it was concluded by Naus and others (2001) that interactions between the Madison and Minnelusa aquifers are an important factor governing the hydraulic behavior of the two aquifers. The exchange of water resulting from general, areal leakage probably is small, relative to that which occurs near artesian springs; however, both processes probably contribute to the control of hydraulic heads in the Black Hills area. Interactions between the aquifers are an important consideration regarding the

hydraulic behavior of the Madison and Minnelusa aquifer system, which has a major influence on the overall hydrology of the Black Hills area, as discussed in the following section.

### **Influence on Overall Hydrology of Black Hills Area**

The Madison and Minnelusa aquifers strongly influence the hydrology of the Black Hills area and have important water-management implications. The ground-water hydrology of the area is dominated by the Madison and Minnelusa aquifers, which receive about 84 percent of estimated recharge to all bedrock aquifers in the study area. The Madison and Minnelusa aquifers are the most heavily used aquifers in the study area, with ongoing development occurring to meet steadily expanding needs for ground-water resources. Surface-water resources, which also are heavily used in the

study area, are influenced by interactions with these aquifers.

Headwater springflow, which originates primarily from the Madison and Minnelusa aquifers in the Limestone Plateau area, provides a reliable source of baseflow in several streams. Relatively stable discharge is an important characteristic of the limestone headwater springs, which generally are influenced primarily by long-term, rather than short-term, climatic conditions. Thus, adequate baseflow for sustaining aquatic populations often can be maintained during extended periods of dry conditions in streams with substantial influence from headwater springflow. A general absence of direct runoff is another distinguishing characteristic of areas with extensive outcrops of the Madison Limestone and Minnelusa Formation.

Streamflow losses that provide recharge to the Madison and Minnelusa aquifers are another important influence on the hydrology of the Black Hills area. Only two streams in the study area maintain perennial flow through loss zones—Whitewood Creek, in which the loss zone probably has been sealed by mine tailings (Hortness and Driscoll, 1998), and Rapid Creek. Spearfish Creek also would maintain perennial flow under natural conditions; however, flow is diverted around the loss zone for hydroelectric power generation. Utilization of surface- and ground-water resources upstream from loss zones has potential to reduce recharge to the Madison and Minnelusa aquifers. In some streams, discharge of limestone headwater springs can provide a relatively consistent source of streamflow for subsequent recharge in loss zones.

Streamflow loss zones create potential for direct introduction of contaminants into the Madison and Minnelusa aquifers, which can have small filtration capacity and large potential for rapid transport of contaminants because of large secondary permeability. Similar concerns exist for all recharge areas of these aquifers, regardless of proximity to streamflow loss zones. The Madison and Minnelusa aquifers are among the most sensitive of all hydrogeologic units in the study area, relative to contamination potential (Davis and others, 1994; Putnam, 2000).

Artesian springflow from the Madison and Minnelusa aquifers is an especially important influence on surface-water resources in the study area. Artesian springflow provides large and consistent baseflow for many streams in exterior areas, where zero-flow conditions commonly occur in streams that are not influenced by artesian springs. This baseflow is especially

important in maintaining adequate flow for aquatic populations and for various water-supply needs including stock water, municipal supply, and irrigation. In many locations irrigation withdrawals are made directly from streams. In addition, artesian springs provide large and consistent baseflow upstream from Angostura and Belle Fourche Reservoirs, which also are heavily used for recreational purposes.

As previously mentioned, artesian springs are essentially a pressure-relief mechanism that influence the upper limit for hydraulic head in the Madison and Minnelusa aquifers. These aquifers have a “maximum-sustainable equilibrium” water level, which is controlled by the discharge of artesian springs, with springflow increasing in response to increasing recharge and water levels. Conversely, artesian springflow decreases in response to decreasing water levels. As discussed previously, hydraulic heads are approximately coincident with land-surface altitudes near some artesian springs (table 18). Thus, large-scale well withdrawals near some artesian springs could diminish springflow before large-scale declines in water levels would occur. However, to some extent, the large recharge potential of the Madison and Minnelusa aquifers may be sufficient to replenish springflow and water levels relatively quickly during episodic periods of prolonged wet conditions.

Additional insights regarding potential effects of large-scale development of the Madison and Minnelusa aquifers can be obtained by reviewing the water budget for these aquifers for the entire Black Hills area (including both South Dakota and Wyoming) that was presented previously in table 14. For this budget, the dominant outflow component is artesian springflow of  $169 \text{ ft}^3/\text{s}$ , which is larger than combined well withdrawals ( $28 \text{ ft}^3/\text{s}$ ) and ground-water outflow from the study area ( $100 \text{ ft}^3/\text{s}$ ). Hypothetically, artesian springflow could be replaced by increased well withdrawals without causing substantial changes in hydraulic gradient or associated ground-water outflow from the study area (figs. 69 and 70).

The previous interpretations could provide insights regarding future management of ground-water resources and potential influences on surface-water resources. Many large springs currently have relatively stable discharge, whereas others, including both small and large springs, have large variability in discharge characteristics. Large-scale development of the Madison and Minnelusa aquifers probably has the potential to influence the balance of this dynamic



“plumbing system.” Potential effects would be most pronounced during prolonged drought periods, which would result in decreased recharge and increased demand. Although discharges of many artesian springs respond slowly to changes in recharge conditions (both decreases and increases), other springs respond more quickly. Similarly, responses to large-scale increases in well withdrawals probably would be distinct for particular withdrawal scenarios.

## REFERENCES

- Amundson, F.D., 1998, Estimated use of water in South Dakota, 1995: U.S. Geological Survey Open-File Report 98-268, 18 p.
- Anderson, M.T., Driscoll, D.G., and Williamson, J.E., 1999, Ground-water and surface-water interactions along Rapid Creek near Rapid City, South Dakota: U.S. Geological Survey Water-Resources Investigations Report 98-4214, 99 p.
- Anna, L.O., 1986, Geologic framework of the ground-water system in Jurassic and Cretaceous rocks in the northern Great Plains, in parts of Montana, North Dakota, South Dakota, and Wyoming: U.S. Geological Survey Professional Paper 1402-B, 36 p.
- Back, W., Hanshaw, B.B., Plummer, L.N., Rahn, P.H., Rightmire, C.T., and Rubin, M., 1983, Process and rate of dedolomitization: Mass transfer and  $^{14}\text{C}$  dating in a regional carbonate aquifer: Geological Society of America Bulletin, v. 94, no. 12, p. 1415-1429.
- Bartlett and West Engineers, Inc., 1998, Piedmont Valley water quality assessment study—Final report: Bismarck, N. Dak., Bartlett and West Engineers, Inc. [variously paged].
- Blankennagel, R.K., Howells, L.W., and Miller, W.R., 1981, Completion and testing of Madison Limestone test well 3, NW 1/4 SE 1/4, sec. 35, T. 2N., R. 27E., Yellowstone County, Montana: U.S. Geological Survey Open-File Report 81-528, 91 p.
- Blankennagel, R.K., Miller, W.R., Brown, D.L., and Cushing, E.M., 1977, Report on preliminary data for Madison Limestone test well 1, NE 1/4 SE 1/4 sec. 15, T. 57N., R. 65W., Crook County, Wyoming: U.S. Geological Survey Open-File Report 77-164, 97 p., 3 plates.
- Boggs, J.M., and Jenkins, A.M., 1980, Analysis of aquifer tests conducted at the proposed Burdock Uranium Mine Site, Burdock, South Dakota: Norris, Tenn., Tennessee Valley Authority, Office of Natural Resources, Division of Natural Resources, Water System Development Branch, Report No. WR28-1-520-109, 73 p.
- Braddock, W.A., 1963, Geology of the Jewel Cave SW Quadrangle, Custer County, South Dakota: U.S. Geological Survey Bulletin 1063-G, p. 217-268.
- Bredehoeft, J.D., Neuzil, C.E., and Milly, P.C.D., 1983, Regional flow in the Dakota aquifer—A study of the role of confining layers: U.S. Geological Survey Water-Supply Paper 2237, 45 p.
- Brown, C.B., 1944, Report on an investigation of water losses in streams flowing east out of the Black Hills, South Dakota: U.S. Soil Conservation Service, Special Report 8, 45 p.
- Bureau of Reclamation, 1999, Annual operating plans, Upper Missouri River Basin: Billings, Mont. (issued annually).
- Busby, J.F., Kimball, B.A., Downey, J.S., and Peter, K.D., 1995, Geochemistry of water in aquifers and confining units of the northern Great Plains in parts of Montana, North Dakota, South Dakota, and Wyoming: U.S. Geological Survey Professional Paper 1402-F, 146 p.
- Busby, J.F., Lee, R., and Hanshaw, B.B., 1983, Major geochemical processes related to the hydrology of the Madison aquifer system and associated rocks in parts of Montana, South Dakota, and Wyoming: U.S. Geological Survey Water-Resources Investigation Report 83-4093, 180 p.
- Busby, J.F., Plummer, L.N., Lee, R.W., and Hanshaw, B.B., 1991, Geochemical evolution of water in the Madison aquifer in parts of Montana, South Dakota, and Wyoming: U.S. Geological Survey Professional Paper 1273-F, 89 p.
- Callahan, M.A., Slimak, M.W., Gabel, N.W., May, I.P., Fowler, C.F., Freed, J.R., Jennings, Patricia, Durfee, R.L., Whitmore, F.C., Maestri, Bruno, Mabey, W.R., Holt, B.R., and Gould, Constance, 1979, Water-related environmental fate of 129 priority pollutants, Volume I—Introduction and technical background, metals and inorganics, pesticides and PCBs: U.S. Environmental Protection Agency, Office of Water Planning and Standards, Office of Water and Waste Management, EPA-440/4-79-029a [variously paged].
- Carlson, C.G., and Anderson, S.B., 1965, Sedimentary and tectonic history of North Dakota part of Williston Basin: Bulletin of the American Association of Petroleum Geologists, v. 49, no. 11, p. 1833-1846.
- Carter, J.M., Driscoll, D.G., and Hamade, G.R., 2001, Estimated recharge to the Madison and Minnelusa aquifers in the Black Hills area, South Dakota: U.S. Geological Survey Water-Resources Investigations Report 00-4278, 66 p.
- Carter, J.M., Driscoll, D.G., Hamade, G.R., and Jarrell, G.J., 2001, Hydrologic budgets for the Madison and Minnelusa aquifers in the Black Hills of South Dakota and Wyoming, water years 1987-96: U.S. Geological Survey Water-Resources Investigations Report 01-4119, 53 p.

- Carter, J.M. and Redden, J.A., 1999a, Altitude of the top of the Inyan Kara Group in the Black Hills area, South Dakota: U.S. Geological Survey Hydrologic Investigations Atlas HA-744-A, 2 sheets, scale 1:100,000.
- 1999b, Altitude of the top of the Minnekahta Limestone in the Black Hills area, South Dakota: U.S. Geological Survey Hydrologic Investigations Atlas HA-744-B, 2 sheets, scale 1:100,000.
- 1999c, Altitude of the top of the Minnelusa Formation in the Black Hills area, South Dakota: U.S. Geological Survey Hydrologic Investigations Atlas HA-744-C, 2 sheets, scale 1:100,000.
- 1999d, Altitude of the top of the Madison Limestone in the Black Hills area, South Dakota: U.S. Geological Survey Hydrologic Investigations Atlas HA-744-D, 2 sheets, scale 1:100,000.
- 1999e, Altitude of the top of the Deadwood Formation in the Black Hills area, South Dakota: U.S. Geological Survey Hydrologic Investigations Atlas HA-744-E, 2 sheets, scale 1:100,000.
- Clark, I.D., and Fritz, P., 1997, Environmental isotopes in hydrogeology: Boca Raton, Fla., Lewis Publishers, 328 p.
- Clawges, R.M., 2000a, Digital map of saturated thickness of the Madison aquifer, Black Hills, South Dakota: U.S. Geological Survey data available on the World Wide Web, accessed July 2, 2001, at URL [http://water.usgs.gov/lookup/getspatial?sd\\_mdsnst\\_thk](http://water.usgs.gov/lookup/getspatial?sd_mdsnst_thk)
- 2000b, Digital map of saturated thickness of the Minnelusa aquifer, Black Hills, South Dakota: U.S. Geological Survey data available on the World Wide Web, accessed July 2, 2001, at URL [http://water.usgs.gov/lookup/getspatial?sd\\_mnlst\\_thk](http://water.usgs.gov/lookup/getspatial?sd_mnlst_thk)
- Cooley, R.L., Konikow, L.F., and Naff, R.L., 1986, Nonlinear-regression groundwater flow modeling of a deep regional aquifer system: Water Resources Research, v. 22, no. 13, p. 1759-1778.
- Craig, H., 1961, Isotopic variations in meteoric waters: Science, v. 133, p. 1702-1703.
- Darton, N.H., and Paige, Sidney, 1925, Central Black Hills [quadrangle], South Dakota: U.S. Geological Survey Atlas of the United States, Folio 219, 34 p.
- Davis, A.D., Long A.J., Nazir, M., and Tan, X., 1994, Ground-water vulnerability in the Rapid Creek Basin above Rapid City, South Dakota—Final Technical Report: Denver, Colo., U.S. Environmental Protection Agency, Region VIII Office, Contract X008788-01-0, 78 p.
- DeWitt, Ed, Redden, J.A., Buscher, David, and Wilson, A.B., 1989, Geologic map of the Black Hills area, South Dakota and Wyoming: U.S. Geological Survey Map I-1910, scale 1:250,000.
- DeWitt, Ed, Redden, J.A., Wilson, A.B., and Buscher, David, 1986, Mineral resource potential and geology of the Black Hills Nations Forest, South Dakota and Wyoming: U.S. Geological Survey Bulletin 1580, 135 p.
- Downey, J.S., 1984, Geohydrology of the Madison and associated aquifers in parts of Montana, North Dakota, South Dakota, and Wyoming: U.S. Geological Survey Professional Paper 1273-G, 47 p.
- 1986, Geohydrology of bedrock aquifers in the northern Great Plains in parts of Montana, North Dakota, South Dakota, and Wyoming: U.S. Geological Survey Professional Paper 1402-E, 87 p.
- Downey, J.S., and Dinwiddie, G.A., 1988, The regional aquifer system underlying the northern Great Plains in parts of Montana, North Dakota, South Dakota, and Wyoming—Summary: U.S. Geological Survey Professional Paper 1402-A, 64 p.
- Driscoll, D.G., 1992, Plan of study for the Black Hills Hydrology Study, South Dakota: U.S. Geological Survey Open-File Report 92-84, 10 p.
- Driscoll, D.G., Bradford, W.L., and Moran, M.J., 2000, Selected hydrologic data, through water year 1998, Black Hills Hydrology Study, South Dakota: U.S. Geological Survey Open-File Report 00-70, 284 p.
- Driscoll, D.G., and Carter J.M., 2001, Hydrologic conditions and budgets in the Black Hills area of South Dakota, through water year 1998: U.S. Geological Survey Water-Resources Investigations Report 01-4226, 143 p.
- Driscoll, D.G., Hamade, G.R., and Kenner, S.J., 2000, Summary of precipitation data compiled for the Black Hills area of South Dakota, water years 1931-98: U.S. Geological Survey Open-File Report 00-329, 151 p.
- Driscoll, D.G., and Hayes, T.S., 1995, Arsenic loads in Spearfish Creek, western South Dakota, water years 1989-91: U.S. Geological Survey Open-File Report 91-249, 194 p.
- Durkin, T.V., 1996, Acid Mine Drainage—Reclamation at the Richmond Hill and Gilt Edge Mines, South Dakota in U.S. Environmental Protection Agency, Managing environmental problems at inactive and abandoned metals mine sites: U.S. Environmental Protection Agency Seminar Publication No. EPA/625/R-95/007, p 54-61.
- Ford, D.C., Lundberg, J., Palmer, A.N., Palmer, M.V., Dreybrodt, W., and Schwarcz, H.P., 1993, Uranium-series dating of the draining of an aquifer—The example of Wind Cave, Black Hills, South Dakota: Geological Society of America Bulletin, v. 105, p. 241-250.
- Fuller, C.C., and Davis, J.A., 1989, Influence of coupling of sorption and photosynthetic processes on trace element cycles in natural water: Nature, v. 340, p. 52-54.
- Fuller, C.C., Davis, J.A., and Waychunas, G.A., 1993, Surface chemistry of ferrihydrite; Part 2, Kinetics of arsenate adsorption and coprecipitation: Geochimica et Cosmochimica Acta, v. 57, no. 10, p. 2271-2282.

- Galloway, J.M., and Strobel, M.L., 2000, Hydrologic characteristics of metamorphic and igneous rocks in the central core of the Black Hills, South Dakota [abs.], in Strobel, M.L., and others, eds., Proceedings of the Hydrology of the Black Hills Conference, South Dakota School of Mines Bulletin 20, p. 87.
- Goddard, K.E., 1989, Composition, distribution, and hydrologic effects of contaminated sediments resulting from the discharge of gold milling wastes to Whitewood Creek at Lead and Deadwood, South Dakota: U.S. Geological Survey Water-Resources Investigations Report 87-4051, 76 p.
- Goddard, K.E., Lockner, T.K., Harms, L.L., and Smith, M.H., 1989, Summary of data pertaining to land use, rainfall, dryfall, stream discharge, and storm runoff collected as part of a study of the effects of urban runoff on Rapid Creek, Rapid City area, South Dakota: U.S. Geological Survey Open-File Report 87-45, 194 p.
- Gott, G.B., Wolcott, D.E., and Bowles, C.G., 1974, Stratigraphy of the Inyan Kara Group and localization of uranium deposits, southern Black Hills, South Dakota and Wyoming: U.S. Geological Survey Professional Paper 763, 57 p.
- Greene, E.A., 1993, Hydraulic properties of the Madison aquifer system in the western Rapid City area, South Dakota: U.S. Geological Survey Water-Resources Investigations Report 93-4008, 56 p.
- 1997, Tracing recharge from sinking streams over spatial dimensions of kilometers in a karst aquifer: *Ground Water*, v. 35, no. 5, p. 898-904.
- 1999, Characterizing recharge to wells in carbonate aquifers using environmental and artificially recharged tracers, in Morganwalp, D.W., and Buxton, H.T., eds., U.S. Geological Survey Toxic Substances Hydrology Program—Proceedings of the Technical Meeting, Charleston, South Carolina, March 8-12, 1999—Volume 3 of 3—Subsurface Contamination from Point Sources: U.S. Geological Survey Water-Resources Investigations Report 99-4018C, p. 803-808.
- Greene, E.A., and Rahn, P.H., 1995, Localized anisotropy in a karst aquifer: *Ground Water*, v. 33, no. 5, p. 806-816.
- Greene, E.A., Shapiro, A.M., and Carter, J.M., 1999, Hydrogeologic characterization of the Minnelusa and Madison aquifers near Spearfish, South Dakota: U.S. Geological Survey Water-Resources Investigations Report 98-4156, 64 p.
- Greene, E.A., Sowards, C.L., and Hansmann, E.W., 1990, Reconnaissance investigation of water quality, bottom sediment, and biota associated with irrigation drainage in the Angostura Reclamation Unit, southwestern South Dakota, 1988-89: U.S. Geological Survey Water-Resources Investigations Report 90-4152, 75 p.
- Gries, J.P., 1975, Mineral and water resources of South Dakota: U.S. Congress, 94th, 1st Session, Interior and Insular Affairs Committee Print, 313 p.
- 1996, Roadside geology of South Dakota: Missoula, Mont., Mountain Press Publishing Company, 358 p.
- Gries, J.P., Rahn, P.H., and Baker, R.K., 1976, A pump test in the Dakota Sandstone at Wall, South Dakota: South Dakota Geological Survey Circular 43, 9 p.
- Harms, L.L., Smith, Marsha, and Goddard, Kim, 1983, Urban runoff control in Rapid City, South Dakota: Rapid City, S. Dak., Black Hills Council of Local Governments, 21 p.
- Hayes, T.S., 1999, Episodic sediment-discharge events in Cascade Springs, southern Black Hills, South Dakota: U.S. Geological Survey Water-Resources Investigations Report 99-4168, 34 p.
- Heath, R.C., 1983, Basic ground-water hydrology: U.S. Geological Survey Water-Supply Paper 2220, 84 p.
- Hem, J.D., 1985, Study and interpretation of chemical characteristics of natural water (3d ed.): U.S. Geological Survey Water-Supply Paper 2254, 263 p.
- Hortness, J.E., and Driscoll, D.G., 1998, Streamflow losses in the Black Hills of western South Dakota: U.S. Geological Survey Water-Resources Investigations Report 98-4116, 99 p.
- Huntoon, P.W., 1985, Rejection of recharge water from Madison aquifer along eastern perimeter of Bighorn Artesian Basin, Wyoming: *Ground Water*, v. 23, no. 3, p. 345-353.
- Imam, Mozaffer, 1991, Factors affecting the yield of Madison wells in the Black Hills: Rapid City, South Dakota School of Mines and Technology, unpublished M.S. thesis, 96 p.
- International Atomic Energy Agency, 1981, Statistical treatment of environmental isotope data in precipitation: Technical Report Series No. 206, 256 p.
- Jarrell, G.J., 2000, Delineation of ground-water basins on the Limestone Plateau, Black Hills, South Dakota: Rapid City, South Dakota School of Mines and Technology, unpublished M.S. thesis, 68 p.
- Johnson, B.N., 1933, A climatological review of the Black Hills: *The Black Hills Engineer*, Rapid City, South Dakota School of Mines and Technology, 71 p.
- Klemp, J.A., 1995, Source aquifers for large springs in northwestern Lawrence County, South Dakota: Rapid City, South Dakota School of Mines and Technology, unpublished M.S. thesis, 175 p.
- Koch, N.C., 1983, Irrigation-water classification diagram for South Dakota: South Dakota Academy of Science Proceedings, v. 62, p. 107-114.
- Konikow, L.F., 1976, Preliminary digital model of ground-water flow in the Madison Group, Powder River Basin and adjacent areas, Wyoming, Montana, South Dakota, North Dakota, and Nebraska: U.S. Geological Survey Water-Resources Investigations Report 63-75, 44 p., 6 plates.

- Kyllonen, D. P., and Peter, K.D., 1987, Geohydrology and water quality of the Inyan Kara, Minnelusa, and Madison aquifers of the northern Black Hills, South Dakota and Wyoming, and Bear Lodge Mountains, Wyoming: U.S. Geological Survey Water-Resources Investigations Report 86-4158, 61 p.
- Long, A.J., 2000, Modeling techniques for karst aquifers—anisotropy, dual porosity, and linear systems analysis: Rapid City, South Dakota School of Mines and Technology, unpublished Ph.D. dissertation, 59 p.
- Luza, K.V., 1969, Origin, distribution, and development of bog iron in the Rochford District, north-central Black Hills, South Dakota: Rapid City, South Dakota School of Mines and Technology, unpublished M.S. thesis, 159 p.
- Michel, R.L., 1989, Tritium deposition in the continental United States, 1953-83: U.S. Geological Survey Water-Resources Investigations Report 89-4072, 46 p.
- Miller, L.D., and Driscoll, D.G., 1998, Streamflow characteristics for the Black Hills of South Dakota, through water year 1993: U.S. Geological Survey Water-Resources Investigations Report 97-4288, 322 p.
- Miller, R.H., and Rahn, P.H., 1974, Recharge to the Dakota Sandstone from outcrops in the Black Hills, South Dakota: Bulletin of the Association of Engineering Geologists, v. 11, no. 3, p. 221-234.
- Miller, W.R., 1976, Water in carbonate rocks of the Madison Group in southeastern Montana; a preliminary evaluation: U.S. Geological Survey Water-Supply Paper 2043, 51 p.
- National Oceanic and Atmospheric Administration, 1998, Climatological data for South Dakota, annual summary: Asheville, N.C., U.S. Department of Commerce (issued annually).
- Naus, C.A., Driscoll, D.G., and Carter, J.M., 2001, Geochemistry of the Madison and Minnelusa aquifers in the Black Hills area, South Dakota: U.S. Geological Survey Water-Resources Investigations Report 01-4129, 118 p.
- Newton, Henry, and Jenney, W.P., 1880, Report of the geology and resources of the Black Hills of Dakota: Washington, D.C., Government Printing Office, 566 p.
- Niven, D.W., 1967, Determination of porosity and permeability of selected sandstone aquifers of South Dakota: Rapid City, South Dakota School of Mines and Technology, unpublished M.S. thesis, 31 p.
- Orr, H.K., 1959, Precipitation and streamflow in the Black Hills: U.S. Department of Agriculture, Forest Service, Rocky Mountain Forest and Range Experiment Station Paper No. 44, 25 p.
- Pakkong, Mongkol, 1979, Ground water of the Boulder Park area, Lawrence County, South Dakota: Rapid City, South Dakota School of Mines and Technology, unpublished M.S. thesis, 91 p., 4 pl.
- Peter, K.D., 1985, Availability and quality of water from the bedrock aquifers in the Rapid City area, South Dakota: U.S. Geological Survey Water-Resources Investigations Report 85-4022, 34 p.
- Peterlin, J.D., 1990, Thermal springs and flow declines of the all River in the southern Black Hills of South Dakota: Rapid City, South Dakota School of Mines and Technology, unpublished M.S. thesis, 83 p.
- Peterson, J.A. 1981, Stratigraphy and sedimentary facies of the Madison Limestone and associated rocks in parts of Montana, North Dakota, South Dakota, Wyoming, and Nebraska: U.S. Geological Survey Open-File Report 81-642, 92 p.
- Plummer, L.N., Busby, J.F., Lee, R.W., and Hanshaw, B.B., 1990, Geochemical modeling of the Madison aquifer in parts of Montana, Wyoming, and South Dakota: Water Resources Research, v. 26, no. 9, p. 1981-2014.
- Putnam, L.D., 2000, Sensitivity of ground water to contamination in Lawrence County, South Dakota: U.S. Geological Survey Water-Resources Investigations Report 00-4103, 55 p.
- Rahn, P.H., 1985, Ground water stored in the rocks of western South Dakota in Rich, F.J., ed., Geology of the Black Hills, South Dakota and Wyoming (2d ed.): Geological Society of America, Field Trip Guidebook, American Geological Institute, p. 154-174.
- Rahn, P.H., Davis, A.D., Webb, C.J., and Nichols, A.D., 1996, Water quality impacts from mining in the Black Hills, South Dakota, USA: Environmental Geology, v. 27, p. 38-53.
- Rahn, P.H., and Gries, J.P., 1973, Large springs in the Black Hills, South Dakota and Wyoming: South Dakota Geological Survey Report of Investigations 107, 46 p.
- Redden, J.A., and Lisenbee, A.L., 1996, Geologic setting, Black Hills, South Dakota in Paterson, C.J., and Kirchner, J.G., eds., Guidebook to the geology of the Black Hills, South Dakota: Rapid City, South Dakota, South Dakota School of Mines and Technology Bulletin No. 19, p. 1-8.
- Rice, L.R., 1970, The treatment of iron and acid stream contamination in the Black Hills of South Dakota: Rapid City, South Dakota School of Mines and Technology, unpublished M.S. thesis, 212 p.
- Roddy, W.R., Greene, E.A., and Sowards, C.L., 1991, Reconnaissance investigation of water quality, bottom sediment, and biota associated with irrigation drainage in the Belle Fourche Reclamation Project, western South Dakota: U.S. Geological Survey Water-Resources Investigations Report 90-4192, 113 p.
- Rounds, D.D., 1991, A reconnaissance-level investigation of selected radionuclides and water-quality characteristics of wells penetrating the Deadwood Formation, Black Hills, South Dakota: Rapid City, South Dakota School of Mines and Technology, unpublished M.S. thesis, 94 p.

- Sandberg, C.A., and Poole, F.G., 1977, Conodont biostratigraphy and depositional complexes of Upper Devonian cratonic-platform and continental shelf rocks in the western United States, *in* Murphy, M.A., Berry, W.B.N., and Sandberg, C.A., eds., *Western North America—Devonian*: University of California at Riverside, Museum Contributions 4, p. 144-182.
- Sando, S.K., Williamson, J.E., Dickerson, K.K., and Wesolowski, E.A., 2001, Irrigation drainage studies of the Angostura Reclamation Unit and the Belle Fourche Reclamation Project, western South Dakota—Results of 1994 sampling and comparisons with 1988 data: U.S. Geological Survey Water-Resources Investigations Report 01-4103, 65 p.
- South Dakota Department of Environment and Natural Resources, 1998, Summary of the mining industry in South Dakota: Minerals and Mining Program, South Dakota Department of Environment and Natural Resources, retrieved Dec. 28, 2000, from URL <http://www.state.sd.us/dent/DES/mining/1998minesum.htm>
- 2001a, Surface water quality—Administrative rules of South Dakota, 74:51: South Dakota Department of Environment and Natural Resources, accessed June 18, 2001, at URL <http://legis.state.sd.us/rules/rules/7451.htm>
- 2001b, Summary of the mining industry in South Dakota, 2000: Minerals and Mining Program, South Dakota Department of Environment and Natural Resources, retrieved July 10, 2001, from URL <http://www.state.sd.us/dent/DES/Mining/Goldrpta3.pdf>
- Stiff, H.A., Jr., 1951, The interpretation of chemical water analysis by means of patterns: *Journal of Petroleum Technology*, v. 3, no. 10, p. 15-17.
- Strobel, M.L., Galloway, J.M., Hamade, G.R., and Jarrell, G.J., 2000a, Potentiometric surface of the Madison aquifer in the Black Hills area, South Dakota: U.S. Geological Survey Hydrologic Investigations Atlas HA-745-D, 2 sheets, scale 1:100,000.
- 2000b, Potentiometric surface of the Minnelusa aquifer in the Black Hills area, South Dakota: U.S. Geological Survey Hydrologic Investigations Atlas HA-745-C, 2 sheets, scale 1:100,000.
- Strobel, M.L., Jarrell, G.J., Sawyer, J.F., Schleicher, J.R., and Fahrenbach, M.D., 1999, Distribution of hydrogeologic units in the Black Hills area, South Dakota: U.S. Geological Survey Hydrologic Investigations Atlas HA-743, 3 sheets, scale 1:100,000.
- Swenson, F.A., 1968, New theory of recharge to the artesian basin of the Dakotas: *Geological Society of America Bulletin* 1081-B, p. 163-182.
- Tan, Xiaodan, 1994, Potentiometric surfaces, recharge rates, and hydraulic conductivities of the Madison and Minnelusa aquifers in the Rapid Creek basin above Rapid City, South Dakota: Rapid City, South Dakota School of Mines and Technology, unpublished M.S. thesis, 74 p.
- Torve, K.C., 1991, Reconnaissance water-quality investigation of bed material, surface water, and ground water of select tributaries draining the mineralized region of Lawrence County near Lead, South Dakota: Rapid City, South Dakota School of Mines and Technology, unpublished M.S. thesis, 109 p.
- Tweto, Ogden, 1975, Laramide (Late Cretaceous-early Tertiary) orogeny in the southern Rocky Mountains, *in* Curtis, B.F., ed., *Cenozoic history of the southern Rocky Mountains*: Geological Society of America Memoir 144, p. 1-44.
- U.S. Department of Commerce, 1999, Climatological data for South Dakota, annual summary: Asheville, North Carolina (issued annually).
- U.S. Department of Interior, 1967, Black Hills area resources study: Washington, D.C., February 1967, 225 p.
- U.S. Environmental Protection Agency, 1986, Quality criteria for water (updated May 1986), Update No. 2: Washington, D.C., Office of Water Regulations and Standards, EPA 440/5/-86-001, 398 p.
- 1991, Lead and copper role fact sheet: U.S. Environmental Protection Agency, Office of Water, EPA 570/9-91-400, 2 p.
- 1994a, Summary of EPA finalized National primary drinking water regulations: U.S. Environmental Protection Agency Region VIII, 7 p.
- 1994b, National primary drinking water standards: U.S. Environmental Protection Agency, Office of Water, EPA 810-F-94-001A, 4 p.
- 1997, National primary drinking water regulations, Code of Federal regulations 40, parts 141 and 143, revised July 1, 1997, p. 288-476.
- 2001, EPA to implement 10 ppb standard for arsenic in drinking water: U.S. Environmental Protection Agency, Office of Water, EPA 815-F-01-010, 2 p.
- U.S. Geological Survey, 1999, The quality of our Nation's waters—Nutrients and pesticides: U.S. Geological Survey Circular 1225, 82 p.
- 2000, Water resources data, South Dakota, water year 1999: U.S. Geological Survey Water-Data Report SD-99-1, 501 p.
- Wahl, K.L., and Wahl, T.L., 1995, Determining the flow of Comal Springs at New Braunfels, Texas: Proceedings of Texas Water '95, A Component Conference of the First International Conference on Water Resources Engineering, American Society of Civil Engineers, August 16-17, 1995, San Antonio, Texas, p. 77-86.
- Whalen, P.J., 1994, Source aquifers for Cascade Springs, Hot Springs, and Beaver Creek Springs in the southern Black Hills of South Dakota: Rapid City, South Dakota School of Mines and Technology, unpublished M.S. thesis, 299 p.

- Whitehead, R.L., 1996, Ground water atlas of the United States—Segment 8, Montana, North Dakota, South Dakota, Wyoming: U.S. Geological Survey Hydrologic Investigations Atlas 730-I, 24 p.
- Williamson, J.E., and Carter, J.M., 2001, Water-quality characteristics for the Black Hills area, South Dakota: U.S. Geological Survey Water-Resources Investigations Report 01-4194, 196 p.
- Williamson, J.E., Goldstein, R.M., and Porter, S.D., 1996, Selected trace metals in water, sediment, plants, and fish in Rapid Creek, Rapid City, South Dakota: U.S. Geological Survey Water-Resources Investigations Report 96-4276, 30 p.
- Williamson, J.E., and Hayes, T.S., 2000, Water-quality characteristics for selected streams in Lawrence County, South Dakota, 1988-92: U.S. Geological Survey Water-Resources Investigations Report 00-4220, 131 p.
- Williamson, J.E., Jarrell, G.J., Clawges, R.M., Galloway, J.M., and Carter, J.M., 2000, Digital data sets for map products produced as part of the Black Hills Hydrology Study, western South Dakota: U.S. Geological Survey Open-File Report 00-471.
- Woodward-Clyde Consultants, 1980, Well-field hydrology technical report for the Energy Transportation Systems Incorporated Coal Slurry Pipeline Project: Woodward-Clyde Consultants, prepared for the U.S. Bureau of Land Management [variously paged].