

EPA Office of Compliance Sector Notebook Project:

Profile of the Metal Casting Industry

October 1998

Office of Compliance
Office of Enforcement and Compliance Assurance
U.S. Environmental Protection Agency
401 M St., SW (MC 2221-A)
Washington, DC 20460

This report is one in a series of volumes published by the U.S. Environmental Protection Agency (EPA) to provide information of general interest regarding environmental issues associated with specific industrial sectors. The documents were developed under contract by Abt Associates (Cambridge, MA), Science Applications International Corporation (McLean, VA), and Booz-Allen & Hamilton, Inc. (McLean, VA). This publication may be purchased from the Superintendent of Documents, U.S. Government Printing Office. A listing of available Sector Notebooks and document numbers is included on the following page.

All telephone orders should be directed to:

Superintendent of Documents
U.S. Government Printing Office
Washington, DC 20402
(202) 512-1800
FAX (202) 512-2250
8:00 a.m. to 4:30 p.m., EST, M-F

Using the form provided at the end of this document, all mail orders should be directed to:

U.S. Government Printing Office
P.O. Box 371954
Pittsburgh, PA 15250-7954

Complimentary volumes are available to certain groups or subscribers, such as public and academic libraries, Federal, State, and local governments, and the media from EPA's National Center for Environmental Publications and Information at (800) 490-9198. For further information, and for answers to questions pertaining to these documents, please refer to the contact names and numbers provided within this volume.

Electronic versions of all Sector Notebooks are available free of charge at the following web address: **www.epa.gov/oeca/sector**. Direct technical questions to the "Feedback" button at the bottom of the web page.

Cover photograph courtesy of American Foundrymen's Society, Inc., Des Plaines, Illinois.

Sector Notebook Contacts

The Sector Notebooks were developed by the EPA's Office of Compliance. Questions relating to the Sector Notebook Project can be directed to:

Seth Heminway, Coordinator, Sector Notebook Project
 US EPA Office of Compliance
 401 M St., SW (2223-A)
 Washington, DC 20460
 (202) 564-7017

Questions and comments regarding the individual documents can be directed to the appropriate specialists listed below.

Document Number	Industry	Contact	Phone (202)
EPA/310-R-95-001.	Dry Cleaning Industry	Joyce Chandler	564-7073
EPA/310-R-95-002.	Electronics and Computer Industry*	Steve Hoover	564-7007
EPA/310-R-95-003.	Wood Furniture and Fixtures Industry	Bob Marshall	564-7021
EPA/310-R-95-004.	Inorganic Chemical Industry*	Walter DeRieux	564-7067
EPA/310-R-95-005.	Iron and Steel Industry	Maria Malave	564-7027
EPA/310-R-95-006.	Lumber and Wood Products Industry	Seth Heminway	564-7017
EPA/310-R-95-007.	Fabricated Metal Products Industry*	Scott Throwe	564-7013
EPA/310-R-95-008.	Metal Mining Industry	Jane Engert	564-5021
EPA/310-R-95-009.	Motor Vehicle Assembly Industry	Anthony Raia	564-6045
EPA/310-R-95-010.	Nonferrous Metals Industry	Jane Engert	564-5021
EPA/310-R-95-011.	Non-Fuel, Non-Metal Mining Industry	Rob Lischinsky	564-2628
EPA/310-R-95-012.	Organic Chemical Industry*	Walter DeRieux	564-7067
EPA/310-R-95-013.	Petroleum Refining Industry	Tom Ripp	564-7003
EPA/310-R-95-014.	Printing Industry	Ginger Gotliffe	564-7072
EPA/310-R-95-015.	Pulp and Paper Industry	Seth Heminway	564-7017
EPA/310-R-95-016.	Rubber and Plastic Industry	Maria Malave	564-7027
EPA/310-R-95-017.	Stone, Clay, Glass, and Concrete Industry	Scott Throwe	564-7013
EPA/310-R-95-018.	Transportation Equipment Cleaning Ind.	Virginia Lathrop	564-7057
EPA/310-R-97-001.	Air Transportation Industry	Virginia Lathrop	564-7057
EPA/310-R-97-002.	Ground Transportation Industry	Virginia Lathrop	564-7057
EPA/310-R-97-003.	Water Transportation Industry	Virginia Lathrop	564-7057
EPA/310-R-97-004.	Metal Casting Industry	Jane Engert	564-5021
EPA/310-R-97-005.	Pharmaceuticals Industry	Emily Chow	564-7071
EPA/310-R-97-006.	Plastic Resin and Man-made Fiber Ind.	Sally Sasnett	564-7074
EPA/310-R-97-007.	Fossil Fuel Electric Power Generation Ind.	Rafael Sanchez	564-7028
EPA/310-R-97-008.	Shipbuilding and Repair Industry	Anthony Raia	564-6045
EPA/310-R-97-009.	Textile Industry	Belinda Breidenbach	564-7022
EPA/310-R-97-010.	Sector Notebook Data Refresh-1997	Seth Heminway	564-7017
EPA/310-R-98-001.	Aerospace Industry	Anthony Raia	564-6045
EPA/310-R-98-002.	Agricultural Chemical, Pesticide, and Fertilizer Industry	Amy Porter	564-4149
EPA/310-R-98-003.	Agricultural Crop Production Industry	Ginah Mortensen	(913)551-7864
EPA/310-R-98-004.	Agricultural Livestock Production Ind.	Ginah Mortensen	(913)551-7864
EPA/310-R-98-005.	Oil and Gas Exploration and Production Industry	Dan Chadwick	564-7054
EPA/310-R-98-008.	Local Government Operations	John Dombrowski	564-7036

*Spanish translations available.

Page iv intentionally left blank.

TABLE OF CONTENTS

LIST OF FIGURES	vii
LIST OF TABLES	vii
LIST OF ACRONYMS	viii
I. INTRODUCTION TO THE SECTOR NOTEBOOK PROJECT	1
A. Summary of the Sector Notebook Project	1
B. Additional Information	2
II. INTRODUCTION TO THE METAL CASTING INDUSTRY	3
A. Introduction, Background, and Scope of the Notebook	3
B. Characterization of the Metal Casting Industry	3
1. Product Characterization	4
2. Industry Size and Geographic Distribution	7
3. Economic Trends	10
III. INDUSTRIAL PROCESS DESCRIPTION	13
A. Industrial Processes in the Metal Casting Industry	13
1. Pattern Making	14
2. Mold and Core Preparation and Pouring	15
3. Furnace Charge Preparation and Metal Melting	29
4. Shakeout, Cooling and Sand Handling	33
5. Quenching, Finishing, Cleaning and Coating	34
6. Die Casting	35
B. Raw Materials Inputs and Pollution Outputs	39
1. Foundries	39
2. Die Casters	43
C. Management of Chemicals in Wastestream	47
IV. CHEMICAL RELEASE AND TRANSFER PROFILE	51
A. EPA Toxic Release Inventory for the Metal Casting Industry	55
1. Toxic Release Inventory for Ferrous and Nonferrous Foundries	55
2. Toxic Release Inventory for Die Casting Facilities	61
B. Summary of Selected Chemicals Released	66
C. Other Data Sources	72
D. Comparison of Toxic Release Inventory Between Selected Industries	74

V. POLLUTION PREVENTION OPPORTUNITIES	77
A. Waste Sand and Chemical Binder Reduction and Reuse	77
1. Casting Techniques Reducing Waste Foundry Sand Generation	78
2. Reclamation and Reuse of Waste Foundry Sand and Metal	79
B. Metal Melting Furnaces	84
C. Furnace Dust Management	87
D. Slag and Dross Management	89
E. Wastewater	91
F. Die Casting Lubrication	92
G. Miscellaneous Residual Wastes	92
VI. SUMMARY OF FEDERAL STATUTES AND REGULATIONS	95
A. General Description of Major Statutes	95
B. Industry Specific Requirements	107
C. Pending and Proposed Regulatory Requirements	111
VII. COMPLIANCE AND ENFORCEMENT HISTORY	113
A. Metal Casting Industry Compliance History	117
B. Comparison of Enforcement Activity Between Selected Industries	119
C. Review of Major Legal Actions	124
1. Review of Major Cases	124
2. Supplementary Environmental Projects (SEPs)	126
VIII. COMPLIANCE ASSURANCE ACTIVITIES AND INITIATIVES	127
A. Sector-related Environmental Programs and Activities	127
1. Federal Activities	127
2. State Activities	129
B. EPA Voluntary Programs	131
C. Trade Association/Industry Sponsored Activity	138
1. Industry Research Programs	138
2. Trade Associations	140
IX. CONTACTS/ACKNOWLEDGMENTS/RESOURCE MATERIALS	143

LIST OF FIGURES

Figure 1: Uses of Cast Metal Products	4
Figure 2: Types of Metals Cast	5
Figure 3: Geographic Distribution of Metal Casting Establishments	9
Figure 4: Sand Mold and Core Cross Section	17
Figure 5: Process Flow and Potential Pollutant Outputs for Typical Green Sand Foundry	19
Figure 6: Investment Flask and Shell Casting	26
Figure 7: Lost Foam Casting Cross Sections	28
Figure 8: Sectional Views of Melting Furnaces	32
Figure 9: Cold (a), and Hot Chamber (b), Die Casting Machines	36
Figure 10: Summary of TRI Releases and Transfers by Industry	75

LIST OF TABLES

Table 1: Facility Size Distribution for the Metal Casting Industry	8
Table 2: Top U.S. Metal Casting Companies	10
Table 3: Comparison of Several Casting Methods	15
Table 4: Summary of Material Inputs and Potential Pollutant Outputs for the Metal Casting Industry	45
Table 5: Source Reduction and Recycling Activity for Foundries	48
Table 6: Source Reduction and Recycling Activity for Die Casting Facilities	49
Table 7: 1995 TRI Releases for Foundries, by Number of Facilities Reporting	57
Table 8: 1995 TRI Transfers for Foundries, by Number and Facilities Reporting	59
Table 9: 1995 TRI Releases for Die Casting Facilities, by Number of Facilities Reporting	62
Table 10: 1995 TRI Transfers for Die Casting Facilities, by Number and Facilities Reporting ..	63
Table 11: Top 10 TRI Releasing Metal Casting Facilities	64
Table 12: Top 10 TRI Releasing Facilities Reporting Metal Casting SIC Codes	65
Table 13: Air Pollutant Releases by Industry Sector (tons/year)	73
Table 14: Toxics Release Inventory Data for Selected Industries	76
Table 15: Five-Year Enforcement and Compliance Summary for the Metal Casting Industry .	117
Table 16: Five-Year Enforcement and Compliance Summary for Selected Industries	120
Table 17: One-Year Enforcement and Compliance Summary for Selected Industries	121
Table 18: Five-Year Inspection and Enforcement Summary by Statute for Selected Industries	122
Table 19: One-Year Inspection and Enforcement Summary by Statute for Selected Industries	123
Table 20: Metal Casting Industry Participation in the 33/50 Program	132

LIST OF ACRONYMS

AFS -	AIRS Facility Subsystem (CAA database)
AFS-	American Foundrymen's Society
AIRS -	Aerometric Information Retrieval System (CAA database)
BIFs -	Boilers and Industrial Furnaces (RCRA)
BOD -	Biochemical Oxygen Demand
CAA -	Clean Air Act
CAAA -	Clean Air Act Amendments of 1990
CERCLA -	Comprehensive Environmental Response, Compensation and Liability Act
CERCLIS -	CERCLA Information System
CFCs -	Chlorofluorocarbons
CO -	Carbon Monoxide
COD -	Chemical Oxygen Demand
CSI -	Common Sense Initiative
CWA -	Clean Water Act
D&B -	Dun and Bradstreet Marketing Index
ELP -	Environmental Leadership Program
EPA -	United States Environmental Protection Agency
EPCRA -	Emergency Planning and Community Right-to-Know Act
FIFRA -	Federal Insecticide, Fungicide, and Rodenticide Act
FINDS -	Facility Indexing System
HAPs -	Hazardous Air Pollutants (CAA)
HSDB -	Hazardous Substances Data Bank
IDEA -	Integrated Data for Enforcement Analysis
LDR -	Land Disposal Restrictions (RCRA)
LEPCs -	Local Emergency Planning Committees
MACT -	Maximum Achievable Control Technology (CAA)
MCLGs -	Maximum Contaminant Level Goals
MCLs -	Maximum Contaminant Levels
MEK -	Methyl Ethyl Ketone
MSDSs -	Material Safety Data Sheets
NAAQS -	National Ambient Air Quality Standards (CAA)
NAFTA -	North American Free Trade Agreement
NCDB -	National Compliance Database (for TSCA, FIFRA, EPCRA)
NCP -	National Oil and Hazardous Substances Pollution Contingency Plan
NEIC -	National Enforcement Investigation Center
NESHAP -	National Emission Standards for Hazardous Air Pollutants
NO ₂ -	Nitrogen Dioxide
NOV -	Notice of Violation
NO _x -	Nitrogen Oxide
NPDES -	National Pollution Discharge Elimination System (CWA)
NPL -	National Priorities List
NRC -	National Response Center
NSPS -	New Source Performance Standards (CAA)

OAR -	Office of Air and Radiation
OECA -	Office of Enforcement and Compliance Assurance
OPA -	Oil Pollution Act
OPPTS -	Office of Prevention, Pesticides, and Toxic Substances
OSHA -	Occupational Safety and Health Administration
OSW -	Office of Solid Waste
OSWER -	Office of Solid Waste and Emergency Response
OW -	Office of Water
P2 -	Pollution Prevention
PCS -	Permit Compliance System (CWA Database)
POTW -	Publicly Owned Treatments Works
RCRA -	Resource Conservation and Recovery Act
RCRIS -	RCRA Information System
SARA -	Superfund Amendments and Reauthorization Act
SDWA -	Safe Drinking Water Act
SEPs -	Supplementary Environmental Projects
SERCs -	State Emergency Response Commissions
SIC -	Standard Industrial Classification
SO ₂ -	Sulfur Dioxide
SO _x -	Sulfur Oxides
TOC -	Total Organic Carbon
TRI -	Toxic Release Inventory
TRIS -	Toxic Release Inventory System
TCRIS -	Toxic Chemical Release Inventory System
TSCA -	Toxic Substances Control Act
TSS -	Total Suspended Solids
UIC -	Underground Injection Control (SDWA)
UST -	Underground Storage Tanks (RCRA)
VOCs -	Volatile Organic Compounds

**METAL CASTING INDUSTRY
(SIC 332 AND 336)**

I. INTRODUCTION TO THE SECTOR NOTEBOOK PROJECT

I.A. Summary of the Sector Notebook Project

Integrated environmental policies based upon comprehensive analysis of air, water and land pollution are a logical supplement to traditional single-media approaches to environmental protection. Environmental regulatory agencies are beginning to embrace comprehensive, multi-statute solutions to facility permitting, enforcement and compliance assurance, education/ outreach, research, and regulatory development issues. The central concepts driving the new policy direction are that pollutant releases to each environmental medium (air, water and land) affect each other, and that environmental strategies must actively identify and address these inter-relationships by designing policies for the "whole" facility. One way to achieve a whole facility focus is to design environmental policies for similar industrial facilities. By doing so, environmental concerns that are common to the manufacturing of similar products can be addressed in a comprehensive manner. Recognition of the need to develop the industrial "sector-based" approach within the EPA Office of Compliance led to the creation of this document.

The Sector Notebook Project was originally initiated by the Office of Compliance within the Office of Enforcement and Compliance Assurance (OECA) to provide its staff and managers with summary information for eighteen specific industrial sectors. As other EPA offices, states, the regulated community, environmental groups, and the public became interested in this project, the scope of the original project was expanded to its current form. The ability to design comprehensive, common sense environmental protection measures for specific industries is dependent on knowledge of several inter-related topics. For the purposes of this project, the key elements chosen for inclusion are: general industry information (economic and geographic); a description of industrial processes; pollution outputs; pollution prevention opportunities; Federal statutory and regulatory framework; compliance history; and a description of partnerships that have been formed between regulatory agencies, the regulated community and the public.

For any given industry, each topic listed above could alone be the subject of a lengthy volume. However, in order to produce a manageable document, this project focuses on providing summary information for each topic. This format provides the reader with a synopsis of each issue, and references where more in-depth information is available. Text within each profile was researched from a variety of sources, and was usually condensed from more detailed sources pertaining to specific topics. This approach allows for a wide coverage of activities that can be further explored based upon the citations

and references listed at the end of this profile. As a check on the information included, each notebook went through an external review process. The Office of Compliance appreciates the efforts of all those that participated in this process and enabled us to develop more complete, accurate and up-to-date summaries. Many of those who reviewed this notebook are listed as contacts in Section IX and may be sources of additional information. The individuals and groups on this list do not necessarily concur with all statements within this notebook.

I.B. Additional Information

Providing Comments

OECA's Office of Compliance plans to periodically review and update the notebooks and will make these updates available both in hard copy and electronically. If you have any comments on the existing notebook, or if you would like to provide additional information, please send a hard copy and computer disk to the EPA Office of Compliance, Sector Notebook Project, 401 M St., SW (2223-A), Washington, DC 20460. Comments can also be uploaded to the Enviro\$en\$e World Wide Web for general access to all users of the system. Follow instructions in Appendix A for accessing this system. Once you have logged in, procedures for uploading text are available from the on-line Enviro\$en\$e Help System.

Adapting Notebooks to Particular Needs

The scope of the industry sector described in this notebook approximates the national occurrence of facility types within the sector. In many instances, industries within specific geographic regions or states may have unique characteristics that are not fully captured in these profiles. The Office of Compliance encourages state and local environmental agencies and other groups to supplement or re-package the information included in this notebook to include more specific industrial and regulatory information that may be available. Additionally, interested states may want to supplement the "Summary of Applicable Federal Statutes and Regulations" section with state and local requirements. Compliance or technical assistance providers may also want to develop the "Pollution Prevention" section in more detail. Please contact the appropriate specialist listed on the opening page of this notebook if your office is interested in assisting us in the further development of the information or policies addressed within this volume. If you are interested in assisting in the development of new notebooks for sectors not already covered, please contact the Office of Compliance at 202-564-2395.

II. INTRODUCTION TO THE METAL CASTING INDUSTRY

This section provides background information on the size, geographic distribution, employment, production, sales, and economic condition of the metal casting industry. Facilities described within this document are described in terms of their Standard Industrial Classification (SIC) codes.

II.A. Introduction, Background, and Scope of the Notebook

The metal casting industry makes parts from molten metal according to an end-user's specifications. Facilities are typically categorized as casting either ferrous or nonferrous products. The metal casting industry described in this notebook is categorized by the Office of Management and Budget (OMB) under Standard Industrial Classification (SIC) codes 332 Iron and Steel Foundries and 336 Nonferrous Foundries (Castings). The die casting industry is contained within the SIC 336 category since die casting establishments primarily cast nonferrous metals. OMB is in the process of changing the SIC code system to a system based on similar production processes called the North American Industrial Classification System (NAICS). (In the NAIC system, iron and steel foundries, nonferrous foundries, and die casters are all classified as NAIC 3315.)

Although both foundries and die casters are included in this notebook, there are significant differences in the industrial processes, products, facility size and environmental impacts between die casters and foundries. Die casting operations, therefore, are often considered separately throughout this notebook.

In addition to metal casting, some foundries and die casters carry out further operations on their cast parts that are not the primary focus of this notebook. Examples include heat treating (e.g. annealing), case hardening, quenching, descaling, cleaning, painting, masking, and plating. Such operations can contribute significantly to a facility's total waste generation. Typical wastes generated during such operations include spent cyanide baths, salt baths, quenchants, abrasive media, solvents and plating wastes. For more information on these processes, refer to the Fabricated Metal Products Industry Sector Notebook.

II.B. Characterization of the Metal Casting Industry

Foundries and die casters that produce ferrous and nonferrous castings generally operate on a job or order basis, manufacturing castings for sale to others companies. Some foundries, termed captive foundries, produce castings as a subdivision of a corporation that uses the castings to produce larger products such as machinery, motor vehicles, appliances or plumbing fixtures. In addition, many facilities do further work on castings such as machining,

assembling, and coating.

II.B.1. Product Characterization

About 13 million tons of castings are produced every year in the U.S. (U.S. DOE, 1996). Most of these castings are produced from recycled metals. There are thousands of cast metal products, many of which are incorporated into other products. Almost 90 percent of all manufactured products contain one or more metal castings (LaRue, 1989). It is estimated that on average, every home contains over a ton of castings in the form of pipe fittings, plumbing fixtures, hardware, and furnace and air conditioner parts. Automobiles and other transportation equipment use 50 to 60 percent of all castings produced - in engine blocks, crankshafts, camshafts, cylinder heads, brake drums or calipers, transmission housings, differential casings, U-joints, suspension parts, flywheels, engine mount brackets, front-wheel steering knuckles, hubs, ship propellers, hydraulic valves, locomotive undercarriages, and railroad car wheels. The defense industry also uses a large portion of the castings produced in the U.S. Typical cast parts used by the military include tank tracks and turrets and the tail structure of the F-16 fighter (Walden, 1995). Some of other common castings include: pipes and pipe fittings, valves, pumps, pressure tanks, manhole covers, and cooking utensils. Figure 1 shows the proportion of various types of castings produced in the U.S.

Figure 1: Uses of Cast Metal Products

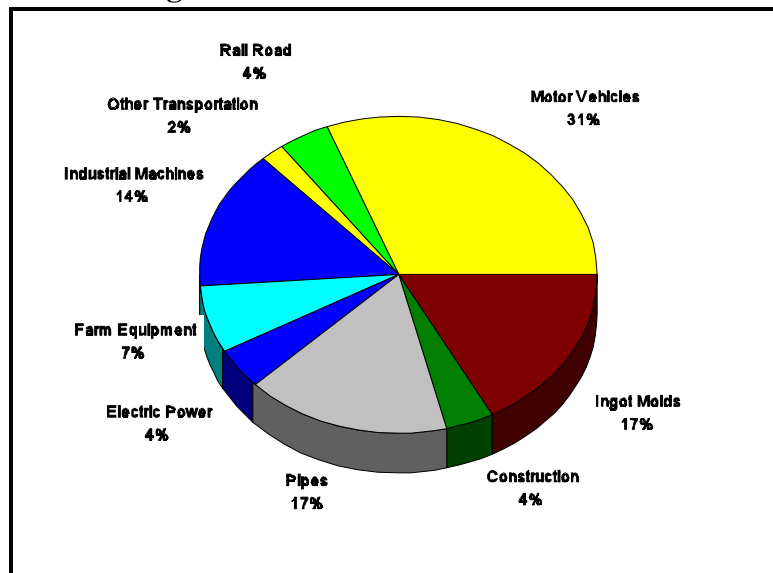

Source: U.S. Department of Energy, 1996.

Iron and Steel (Ferrous) Castings

Depending on the desired properties of the product, castings can be formed from many types of metals and metal alloys. Iron and steel (ferrous) castings are categorized by four-digit SIC code by the Bureau of Census according to the type of iron or steel as follows:

- SIC 3321 - Gray and Ductile Iron Foundries
- SIC 3322 - Malleable Iron Foundries
- SIC 3324 - Steel Investment Foundries
- SIC 3325 - Steel Foundries, Not Elsewhere Classified

Gray and Ductile Iron make up almost 75 percent of all castings (ferrous and nonferrous) by weight (see Figure 2). Gray iron contains a higher percentage of carbon in the form of flake graphite and has a lower ductility than other types of iron. It is used extensively in the agricultural, heavy equipment, engine, pump, and power transmission industries. Ductile iron has magnesium or cerium added to change the form of the graphite from flake to nodular. This results in increased ductility, stiffness, and tensile strength (Loper, 1985).

Figure 2: Types of Metals Cast

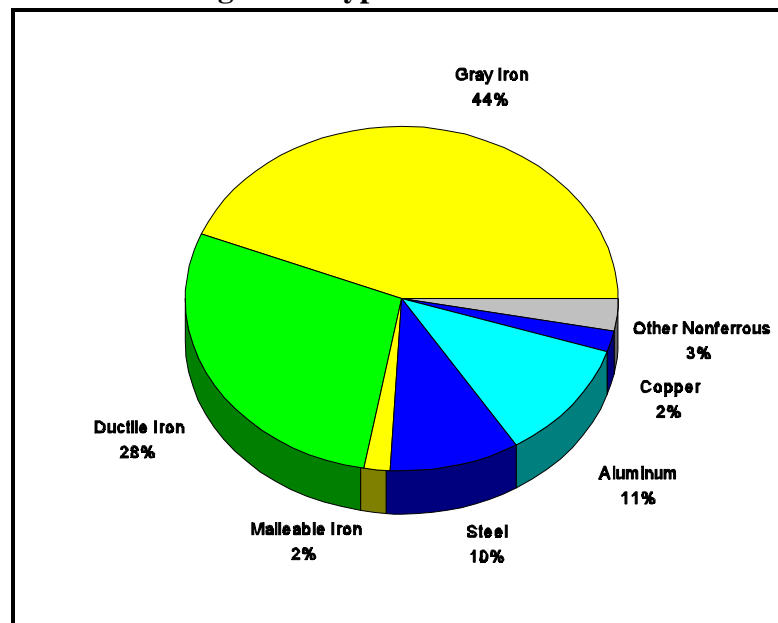

Source: U.S. Department of Energy, 1996.

Malleable iron foundries produce only about two percent of all castings (ferrous and nonferrous). Malleable iron contains small amounts of carbon, silicon, manganese, phosphorus, sulfur and metal alloys to increase strength and endurance. Malleable iron has excellent machinability and a high resistance to atmospheric corrosion. It is often used in the electrical power, conveyor and handling equipment, and railroad industries.

Compared to steel, gray, ductile, and malleable iron are all relatively

inexpensive to produce, easy to machine, and are widely used where the superior mechanical properties of steel are not required (Loper, 1985).

Steel castings make up about 10 percent of all castings (ferrous and nonferrous). In general, steel castings have better strength, ductility, heat resistance, durability and weldability than iron castings. There are a number of different classes of steel castings based on the carbon or alloy content, with different mechanical properties. A large number of different alloying metals can be added to steel to increase its strength, heat resistance, or corrosion resistance (Loper, 1985). The steel investment casting method produces high-precision castings, usually smaller castings. Examples of steel investment castings range from machine tools and dies to golf club heads.

Nonferrous Castings

Nonferrous castings are categorized by four-digit SIC code by the Bureau of Census according to the type of metal as follows:

SIC 3363 - Aluminum Die-Castings

SIC 3364 - Nonferrous Die-Castings, Except Aluminum

SIC 3365 - Aluminum Foundries

SIC 3366 - Copper Foundries

SIC 3369 - Nonferrous Foundries, Except Aluminum and Copper

Nonferrous foundries often use the same basic molding and casting techniques as ferrous foundries. Many foundries cast both ferrous and nonferrous metals. Aluminum, copper, zinc, lead, tin, nickel, magnesium and titanium are the nonferrous metals of primary commercial importance. Usually, these metals are cast in combinations with each other or with some of about 40 other elements to make many different nonferrous alloys. A few of the more common nonferrous alloys are: brass, bronze, nickel-copper alloys (Monel), nickel-chromium-iron alloys, aluminum-copper alloys, aluminum-silicon alloys, aluminum-magnesium alloys, and titanium alloys.

Nonferrous metals are used in castings that require specific mechanical properties, machinability, and/or corrosion resistance (Kunsmann, 1985). Aluminum and aluminum alloy castings are produced in the largest volumes; 11 percent of all castings (ferrous and nonferrous) by weight are aluminum. Copper and copper alloy castings make up about two percent of all castings by weight (DOE, 1996). Figure 2 shows the proportions of raw material types used in castings in the U.S.

About 9 percent by weight of all cast metal products are produced using die casting techniques (DOE, 1996). Die casting is cost effective for producing large numbers of a casting and can achieve a wide variety of sizes and shapes with a high degree of accuracy. Holes, threads, and gears can be cast,

reducing the amount of metal to be machined from the casting. Most die castings are aluminum; however, lead, tin, zinc, copper, nickel, magnesium, titanium, and beryllium alloys are also die cast. Die casts are usually limited to nonferrous metals and are often under ten pounds. A wide variety of products are produced using the die casting process, ranging from tiny wrist watch parts to one-piece automobile engine blocks (Street, 1977). Other typical die castings include: aluminum transmission cases, bearings, bushings, valves, aircraft parts, tableware, jewelry and household appliance parts.

II.B.2. Industry Size and Geographic Distribution

According to the *1992 Census of Manufacturers* data, there are approximately 2,813 metal casting facilities under SIC codes 332 and 336. The payroll for 1992 totaled \$5.7 billion for a workforce of 158,000 employees, and value of shipments totaled \$18.8 billion. The industry's own estimates of the number of facilities and employment are somewhat higher at 3,100 facilities employing 250,000 in 1994 (Cast Metals Coalition, 1995). Based on the Census of Manufacturers data, the industry is labor intensive. The value of shipments per employee, a measure of labor intensity, is \$119,000 that is less than half of the steel manufacturing industry value (\$245,000 per employee) and less than seven percent of the petroleum refining industry value (\$1.8 million per employee).

Most metal casting facilities in the U.S. are small. About seventy percent of the facilities employ fewer than 50 people (see Table 1). Most metal casting facilities manufacture castings for sale to other companies (U.S. Census of Manufacturers, 1992). An important exception are the relatively few (but large) "captive" foundries operated by large original equipment manufacturers (OEM's) including General Motors, Ford, Chrysler, John Deere, and Caterpillar. OEM's account for a large portion of the castings produced and employ a significant number of the industry's workforce.

Although die casting establishments account for only about 9 percent of cast products by weight, they make up about 20 percent of metal casting establishments and value of sales (U.S. Census of Manufacturers, 1992). In proportion to the industry size, there is very little difference between the size distribution of foundries and die casters.

Employees per Facility	Ferrous and Nonferrous Foundries (SIC 332, 3365, 3366, and 3369)		Die Casting Establishments (SIC 3363 and 3364)	
	Number of Facilities	Percentage of Facilities	Number of Facilities	Percentage of Facilities
1-9	742	33%	167	28%
10-49	843	38%	214	36%
50-249	494	22%	186	31%
250-499	90	4%	25	4%
500-2499	43	2%	4	1%
2500 or more	4	0%	0	0%
Total	2216	100%	596	100%

Source: U.S. Department of Commerce, Census of Manufacturers, 1992.

Geographic Distribution

The geographic distribution of the metal casting industry resembles that of the iron and steel industry. The highest geographic concentration of facilities is in the Great Lakes, midwest, southeast regions and California. The top states by number of facilities in order are: California, Ohio, Pennsylvania, Michigan, Illinois, Wisconsin, and Indiana. Figure 3 shows the U.S. distribution of facilities based on 1992 data from the U.S. Census of Manufacturers. Historically, locations for metal casting establishments were selected for their proximity to raw materials (iron, steel, and other metals), coal, and water for cooling, processing, and transportation. Traditional metal casting regions included the Monongahela River valley near Pittsburgh and along the Mahoning River near Youngstown, Ohio. The geographic concentration of the industry is changing as facilities are built where scrap metal and electricity are available at a reasonable cost and there is a local market for the cast products.

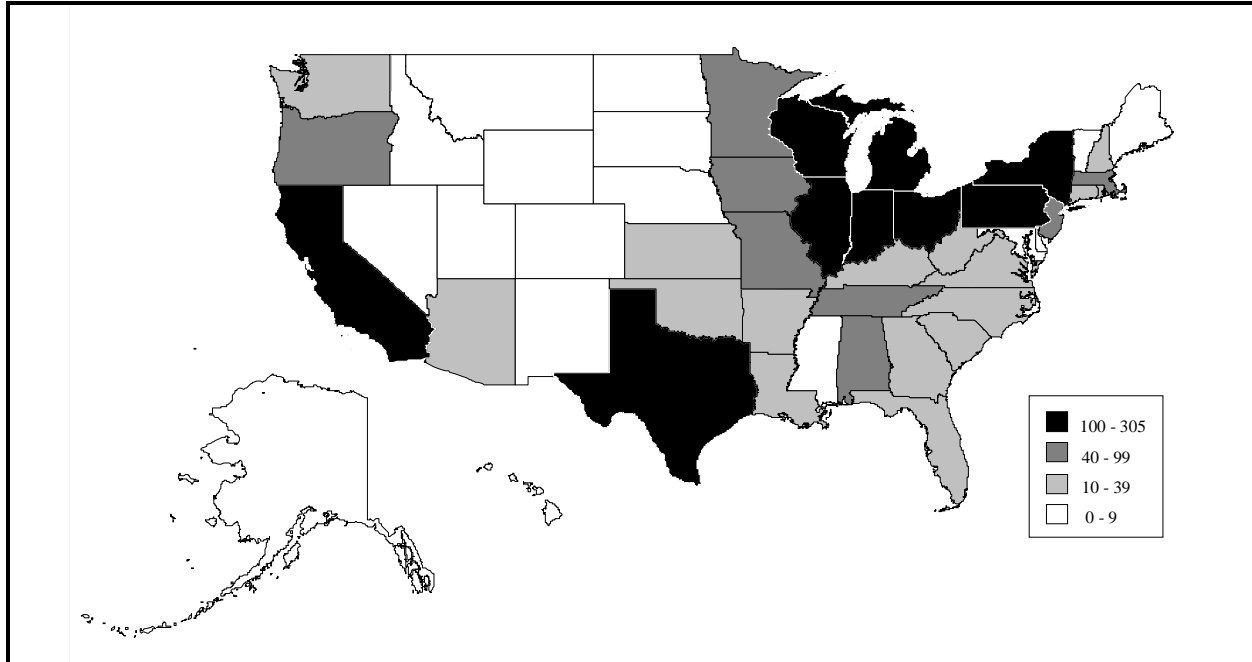
Figure 3: Geographic Distribution of Metal Casting Establishments

Source: U.S. Census of Manufacturers, 1992.

Dun & Bradstreet's *Million Dollar Directory*, compiles financial data on U.S. companies including those operating within the metal casting industry. Dun & Bradstreet ranks U.S. companies, whether they are a parent company, subsidiary or division, by sales volume within their assigned 4-digit SIC code. Readers should note that: (1) companies are assigned a 4-digit SIC that resembles their principal industry most closely; and (2) sales figures include total company sales, including subsidiaries and operations (possibly not related to metal casting). Additional sources of company specific financial information include Standard & Poor's *Stock Report Services*, *Ward's Business Directory of U.S. Private and Public Companies*, Moody's *Manuals*, and annual reports.

Table 2: Top U.S. Metal Casting Companies

Rank ^a	Company ^b	1995 Sales (millions of dollars)
1	Howmet Corporation - Greenwich, CT	900
2	Newell Operating Co. - Freeport, IL	796
3	CMI International Inc. - Southfield, MI	561
4	Precision Castparts Corporation - Portland, OR	557
5	Grede Foundries - Milwaukee, WI	460
6	United States Pipe and Foundry - Birmingham, AL	412
7	George Koch Sons, Inc.	390
8	Varlen Corporation - Naperville, IL	387
9	Allied Signal, Inc.	260
10	North American Royalties, Inc.	254

Note: ^aNot all sales can be attributed to the companies' metal casting operations.

^b Companies shown listed SIC 332, 3363, 3364, 3365, 3369. Many large companies operating captive metal casting facilities produce other goods and are not shown here.

Source: *Dunn & Bradstreet's Million Dollar Directory - 1996.*

II.B.3. Economic Trends

The U.S. metal casting industry experienced an unprecedented drop in production during the 1970's and 1980's. Production of cast metal products declined from 19.6 million tons in 1972 to 11.3 million tons in 1990. During this period over 1,000 metal casting facilities closed (DOE, 1996). A number of reasons have been given for this decline including: decreased U.S. demand for cast metal resulting from decreases in automobile production and smaller, lighter weight vehicles for increased fuel efficiency; increased foreign competition; increased use of substitute materials such as plastics, ceramics, and composites; and increased costs to comply with new environmental and health and safety regulations.

The metal casting industry began to recover in the early 1990's; however, it still produces less than in the early 1970's. The recovery has been attributed to increases in domestic demand in part due to increases in automobile production. In addition, exports of castings have increased and imports have decreased. Between 1993 and 1994 alone the U.S. increased its share of world metal casting production from 18 percent to 20 percent. The increases in production came primarily from increases in capacity utilization at existing

facilities rather than an increase in facilities. In fact, the American Foundrymen's Society estimates that the number of metal casting facilities decreased by over 200 between 1990 and 1994 (DOE, 1996).

In 1972, only five percent of all castings were aluminum. Today aluminum accounts for over 11 percent of the market (DOE, 1996). Aluminum castings are steadily comprising a larger share of the castings market as their use in motor vehicle and engine applications continues to grow. To produce lighter weight, more fuel efficient vehicles, the automobile industry is in the process redesigning the engine blocks, heads and other parts of passenger cars and light trucks for aluminum. Cast aluminum is expected to increase from 140 pounds per vehicle in 1995 to 180 pounds per vehicle in 2004. This is primarily at the expense of gray iron which will decrease from 358 pounds per vehicle in 1995 to 215 pounds in 2004 (*Modern Casting*, September, 1995).

The U.S. metal casting industry that emerged from the two decades of decline in the 1970's and 1980's is stronger and more competitive. The industry is developing new markets and recapturing old markets. Research and development has resulted in technological advances that have improved product quality, overall productivity and energy efficiency. Important recent technological advances have included Computer Aided Design (CAD) of molds and castings, the use of sensors and computers to regulate critical parameters within the processes, and the use of programmable robots to perform dangerous, time consuming or repetitive tasks.

To stay competitive, the industry has identified the following priority areas for research and development to improve its processes and products:

- improving casting technologies
- developing new casting materials (alloys) and die materials
- developing higher strength and lower weight castings
- improving process controls
- improving dimensional control
- improving the quality of casting material
- reducing casting defects (DOE, March 1996)
- developing environmentally improved materials to meet today's regulations

(AFS, 1997)

Research into new casting methods and improvements in the current methods are resulting in improved casting quality, process efficiency, and environmental benefits.

Page 12 intentionally left blank.

III. INDUSTRIAL PROCESS DESCRIPTION

This section describes the major industrial processes within the metal casting industry, including the materials and equipment used and the processes employed. The section is designed for those interested in gaining a general understanding of the industry, and for those interested in the inter-relationship between the industrial process and the topics described in subsequent sections of this profile -- pollutant outputs, pollution prevention opportunities, and Federal regulations. This section does not attempt to replicate published engineering information that is available for this industry. Refer to Section IX for a list of resource materials and contacts that are available.

This section specifically contains a description of commonly used production processes, associated raw materials, the by-products produced or released, and the materials either recycled or transferred off-site. This discussion, coupled with schematic drawings of the identified processes, provide a concise description of where wastes may be produced in the process. This section also describes the potential fate (via air, water, and soil pathways) of these waste products.

III.A. Industrial Processes in the Metal Casting Industry

Many different metal casting techniques are in use today. They all have in common the construction of a mold with a cavity in the external shape of the desired cast part followed by the introduction of molten metal into the mold.

For the purposes of this profile, the metal casting process has been divided into the following five major operations:

- Pattern Making
- Mold and Core Preparation and Pouring
- Furnace Charge Preparation and Metal Melting
- Shakeout, Cooling and Sand Handling
- Quenching, Finishing, Cleaning and Coating

All five operations may not apply to each casting method. Since the major variations between processes occur in the different types of molds used, Section III.A.2 - Mold and Core Preparation is divided into subsections describing the major casting processes. In addition to the casting techniques described below, there are numerous special processes and variations of those processes that cannot be discussed here. Nevertheless, such processes may play an important role in a facility's efforts to comply with environmental requirements. Refer to Section IX for a list of references providing more detail on casting processes.

Note that die casting operations have been presented separately in Section

III.A.6. The different processes, equipment, and environmental impacts of die casting do not fit easily into operations outlined above.

III.A.1. Pattern Making

Pattern making, or foundry tooling, requires a high level of skill to achieve the close tolerances required of the patterns and coreboxes. This step is critical in the casting process since the castings produced can be no better than the patterns used to make them. In some pattern making shops, computer-aided drafting (CAD) is used in the design of patterns. Cutter tool paths are designed with computer-aided manufacturing (CAM). Numerical output from these computers is conveyed to computer-numerical-controlled (CNC) machine tools, which then cut the production patterns to shape. Such computer-aided systems have better dimensional accuracy and consistency than hand methods (LaRue, 1989).

Patterns and corebox materials are typically metal, plastic, wood or plaster. Wax and polystyrene are used in the investment and lost foam casting processes, respectively. Pattern makers have a wide range of tools available including wood working and metal machining tools. Mechanical connectors and glues are used to join pattern pieces. Wax, plastic or polyester putty are used as “fillet” to fill or round the inside of square corners (LaRue, 1989).

Wastes Generated

Very little waste is generated during pattern making compared to other foundry operations. Typical pattern shop wastes include scrap pattern materials (wood, plastics, metals, waxes, adhesives, etc.) and particulate emissions from cutting, grinding and sanding operations. Waste solvents and cleaners may be generated from equipment cleaning.

Table 3: Comparison of Several Casting Methods (approximate and depending upon the metal)					
	Green Sand Casting	Permanent Mold Cast	Die Casting	Sand-Shell CO₂-Core Casting	Investment Casting
Relative cost in quantity	low	low	lowest	medium high	highest
Relative cost for small number	lowest	high	highest	medium high	medium
Permissible weight of casting	up to about 1 ton	100 lbs.	60 lbs.	Shell: ozs. - 250 lbs. CO ₂ : 1/2 lbs. - tons	Ozs. - 100 lbs.
Thinnest section castable, inches	1/10	1/8	1/32	1/10	1/16
Typical dimensional tolerance, inches (not including parting lines)	.012	0.03	0.01	.010	0.01
Relative surface finish	fair to good	good	best	Shell: good CO ₂ : fair	very good
Relative mechanical properties	good	good	very good	good	fair
Relative ease of casting complex design	fair to good	fair	good	good	best
Relative ease of changing design in production	best	poor	poorest	fair	fair
Range of alloys that can be cast	unlimited	copper base and lower melting point metals preferable	aluminum base and lower melting preferable	unlimited	limited

Source: American Foundrymen's Society, 1981.

III.A.2. Mold and Core Preparation and Pouring

The various processes used to cast metals are largely defined by the procedures and materials used to make the molds and cores. Table 3 summarizes the major casting methods and their applications. A mold and

cores (if required) are usually made for each casting. These molds and cores are destroyed and separated from the casting during shakeout (see Section III.A.4 - Shakeout, Cooling and Sand Handling). (Exceptions include the permanent mold process and die casting process in which the molds are used over and over again.) Most sand is reused over and over in other molds; however, a portion of sand becomes spent after a number of uses and must be removed as waste. Mold and core making are, therefore, a large source of foundry wastes.

Sand Molds and Cores

For most sand casting techniques, the following summary of the process applies (see Figure 4). First, engineers design the casting and specify the metal or alloy to be cast. Next, a pattern (replica of the finished piece) is constructed from either plastic, wood, metal, plaster or wax. Usually, the pattern is comprised of two halves. The molding sand is shaped around the pattern halves in a metal box (flask) and then removed, leaving the two mold halves. The top half of the mold (the cope) is assembled with the bottom half (the drag) which sits on a molding board. The interface between the two mold halves is called a parting line. Weights may be placed on the cope to help secure the two halves together. The molten metal is poured or injected into a hole in the cope called a sprue or sprue basin which is connected to the mold cavity by runners. The runners, sprue, gates, and risers comprise the mold's gating system, which is designed to carry molten metal smoothly to all parts of the mold. The metal is then allowed to solidify within the space defined by the mold.

Since the molds themselves only replicate the external shape of the pattern, cores are placed inside the mold to form any internal cavities. Cores are produced in a core box, which is essentially a permanent mold that is developed in conjunction with the pattern. So that molten metal can flow around all sides of the cores, they are supported on core prints (specific locations shaved into the mold) or on by metal supports called chaplets.

Foundry molds and cores are most commonly constructed of sand grains bonded together to form the desired shape of the casting. Sand is used because it is inexpensive, is capable of holding detail, and resists deformation when heated. Sand casting affords a great variety of casting sizes and complexities. Sand also offers the advantage of reuse of a large portion of the sand in future molds. Depending on the quantity of castings, however, the process can be slower and require more man-hours than processes not requiring a separate mold for each casting. In addition, castings from sand molds are dimensionally less accurate than those produced from some other techniques and often require a certain amount of machining (USITC, 1984). The pattern making, melting, cleaning, and finishing operations are essentially the same whether or not sand molds are used. Sand molds and cores will,

however, require the additional operational steps involved with handling quantities of used mold and core sand (see Section III.A.5 - Sand Handling).

In general, the various binding systems can be classified as either clay bonded sand (green sand) or chemically bonded sand. The type of binding system used depends on a number of production variables, including the temperature of the molten metal, the casting size, the types of sand used, and the alloys to be cast. The differences in binding systems can have an impact on the amounts and toxicity of wastes generated and potential releases to the environment.

Figure 4: Sand Mold and Core Cross Section

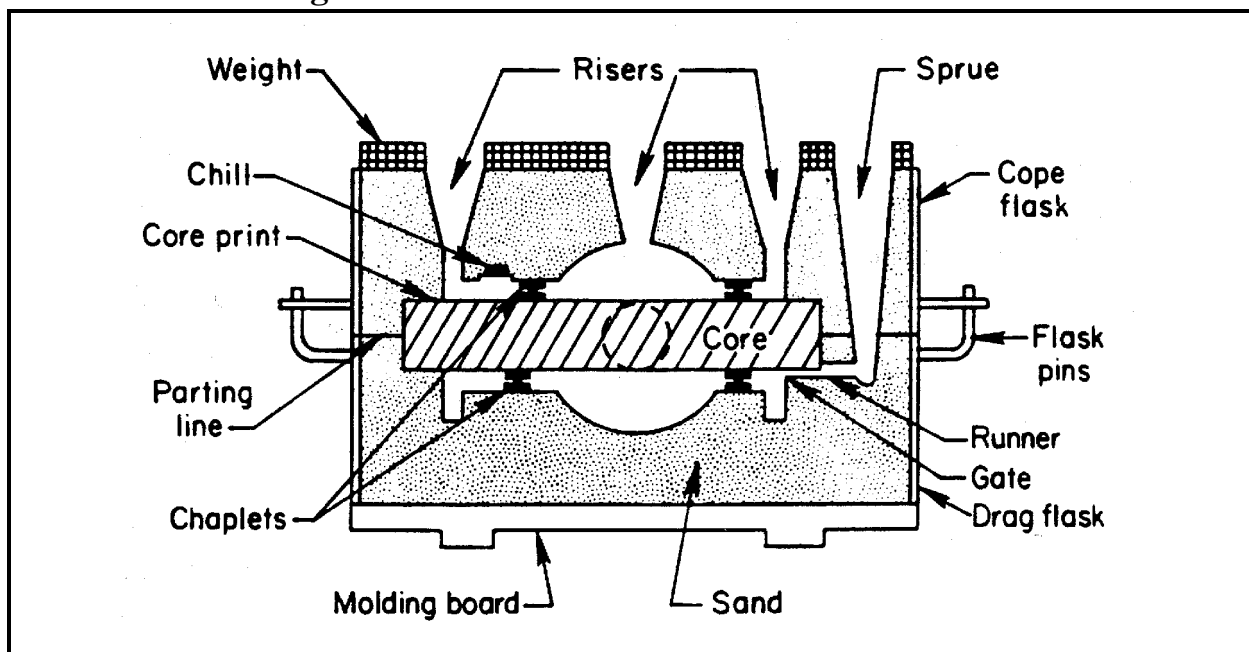

Source: American Foundrymen's Society, 1981.

Some sand molding techniques utilize chemical binders which then require that the mold halves be heat treated or baked in order to activate the binders. In order to pour molten metal into the mold when the cope and drag are latched together, runners are cut or molded into each half. Runners are connected to the mold cavity with a gate which is usually cut into the cope. A sprue is cut or molded through the cope to the runners such that when molten metal is poured into the hole through the cope, it travels through the runners and gate into the mold. Often risers are also cut into the mold halves. After pouring, risers provide a reservoir of molten metal to areas of the casting that solidify last. If metal is not supplied to these areas, the casting will have shrinkage defects.

Cores require different physical characteristics than molds; therefore, the

binding systems used to make cores may be different from those used for molds. Cores must be able to withstand the strong forces of molten metal filling the mold, and often must be removed from small passages in the solidified casting. This means that the binding system used must produce strong, hard cores that will collapse for removal after the casting has hardened. Therefore, cores are typically formed from silica sand (and occasionally olivine or zircon sand), and strong chemical binders (U.S. EPA, 1992). The sand and binder mix is placed in a core box where it hardens into the desired shape and is removed. Hardening, or curing, is accomplished with heat, a chemical reaction, or a catalytic reaction. The major binding systems in use for molds and cores are discussed below.

Green Sand

Green sand is the most common molding process, making about 90% of castings produced in the U.S. Green sand is not used to form cores. Cores are formed using one of the chemical binding systems. Green sand is the only process that uses a moist sand mix. The mixture is made up of about 85 to 95 percent silica (or olivine or zircon) sand, 4 to 10 percent bentonite clay, 2 to 10 percent carbonaceous materials such as powdered (sea) coal, petroleum products, corn starch or wood flour, and 2 to 5 percent water (AFS, 1996). The clay and water act as the binder, holding the sand grains together. The carbonaceous materials burn off when the molten metal is poured into the mold, creating a reducing atmosphere which prevents the metal from oxidizing while it solidifies (U.S. EPA, 1992).

Advantages and Disadvantages

Green sand, as exemplified by its widespread use, has a number of advantages over other casting methods. The process can be used for both ferrous and non-ferrous metal casting and it can handle a more diverse range of products than any other casting method. For example, green sand is used to produce both small precision castings and large castings of up to a ton. If uniform sand compaction and accurate control of sand properties are maintained, very close tolerances can be obtained. The process also has the advantage of requiring a relatively short time to produce a mold compared to many other processes. In addition, the relative simplicity of the process makes it ideally suited to a mechanized process (AFS, 1989).

Wastes Generated

Sand cores that are used in molds break down and become part of the mold sand. Foundries using green sand molds generate waste sand that becomes spent after it has been reused in the process a number of times, as a portion must be disposed of to prevent the build up of grains that are too fine. Waste chemically bonded core sands are also generated. Typically, damaged cores are not reusable and must be disposed as waste.

Figure 5: Process Flow and Potential Pollutant Outputs for Typical Green Sand Foundry

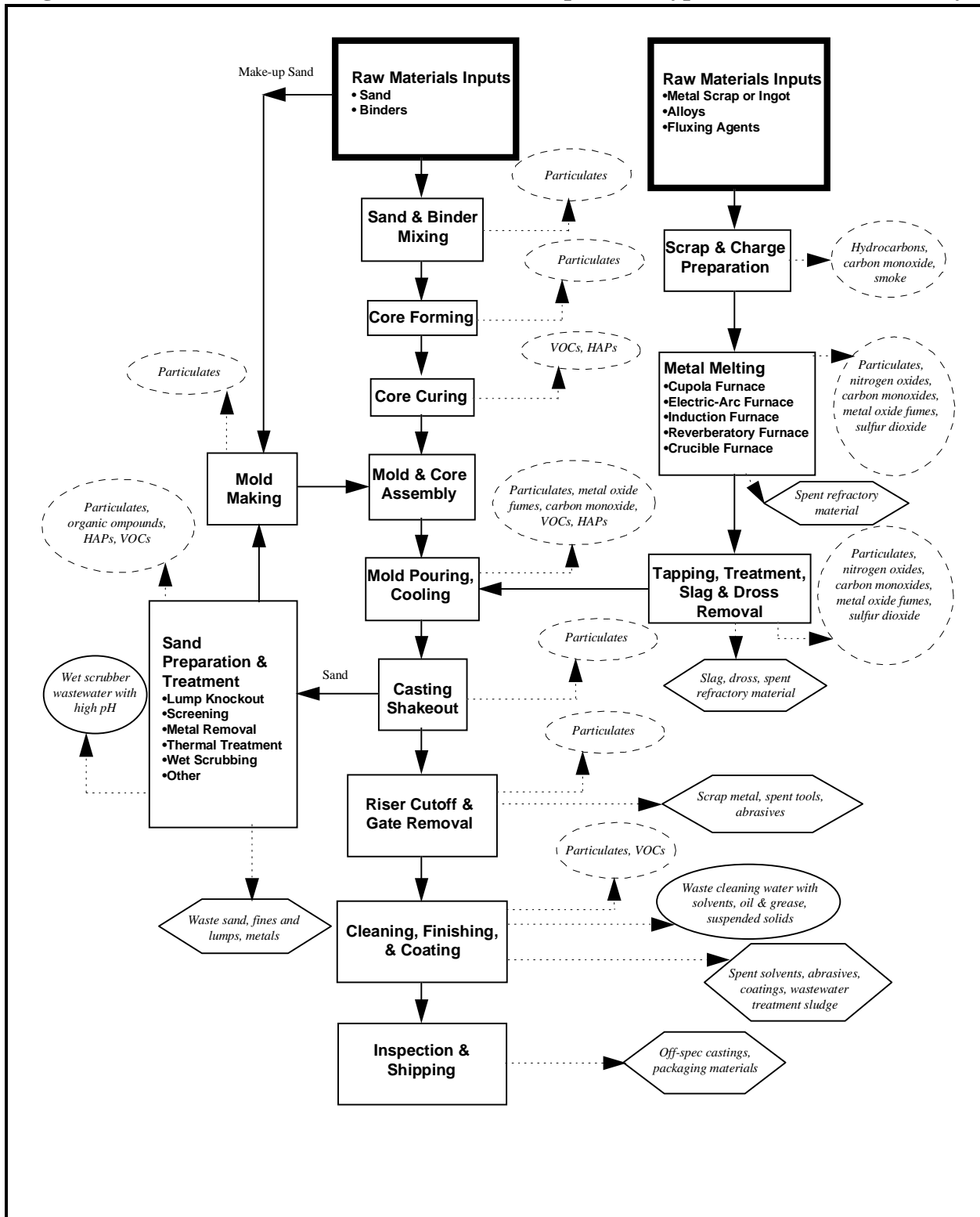

Source: Adapted from Kotzin, Air Pollution Engineering Manual: Steel Foundries, 1992.

ticulate emissions are generated during mixing, molding and core making operations. In addition, gaseous and metal fume emissions develop when molten metal is poured into the molds and a portion of the metal volatilizes and condenses. When green sand additives and core sand binders come into contact with the molten metal, they produce gaseous emissions such as carbon monoxide, organic compounds, hydrogen sulfide, sulfur dioxide, nitrous oxide, benzene, phenols, and other hazardous air pollutants (HAPs) (Twarog, 1993). Wastewater containing metals and suspended solids may be generated if the mold is cooled with water.

Chemical Binding Systems

Chemical binding systems are primarily used for core making. Green sand is not used for cores because, chemically bound sand is stronger, harder, and can be more easily removed from the cavity after the metal has solidified. Almost every foundry using sand molds uses one or more of the chemical binding systems described below in constructing sand cores. Although some foundries also use chemical binding systems to construct molds, the much more simple, quick and inexpensive green sand molds described previously dominate the industry in terms of tons of castings produced. When chemical binding systems are used for mold making, the “shell-mold” system is most often used. Chemical bonding systems work through either thermal setting, chemical or catalytic reactions. The major thermal setting systems include: oil-bake, shell core/mold, hot box, and warm box. The major catalytic systems are the no-bake and cold box systems (U.S. EPA, 1993).

Oil-Bake

The traditional method used to produce cores is the oil-bake, or core-oil system. The oil-bake system uses oil and cereal binders mixed with sand. The core is shaped in a core box and then baked in an oven to harden it. Oils used can be natural, such as linseed oil, or synthetic resins, such as phenolic resins. The oil-bake system was used almost exclusively before 1950, but has now been largely replaced by other chemical binding systems (U.S. EPA, 1981).

Shell Core

The shell core system uses sand mixed with synthetic resins and a catalyst. The resins are typically phenolic or furan resins, or mixtures of the two. Often the shell core sand is purchased as dry coated sand. The catalyst is a weak aqueous acid such as ammonium chloride. The sand mixture is shaped in a heated metal core box. Starting from the outside edge of the core box and moving through the sand towards the center of the core box, the heat begins to cure the sand mix into a hard mass. When the outside 1/8 to 3/16 inches of sand has been cured, the core box is inverted. The uncured sand pours out of the core box leaving a hard sand core shell behind. The shell core is then removed from the core box, allowed to cure for an addition few minutes and is then ready for placement in the mold (LaRue, 1989). The system has the advantage of using less sand and binders than other systems; however, shell sand may be more expensive than sand used in other sand processes.

Shell Mold

The shell mold system is similar to the shell core system, but is used to construct molds instead of cores. In this process, metal pattern halves are preheated, coated with a silicone emulsion release agent, and then covered by the resin-coated sand mixture. The heat from the patterns cures the sand mix and the mold is removed after the desired thickness of sand is obtained. The silicone emulsion acts as a mold release allowing the shell mold to be removed from the pattern after curing (LaRue, 1989).

Hot Box Core

The hot box process uses a phenolic or furan resin and a weak acid catalyst that are mixed with sand to coat the surface of the grains. The major difference between this system and the shell core system is that the core box is heated to about 450 to 550 °F until the entire core has become solidified (Twarog, 1993). The system has the advantage of very fast curing times and a sand mix consistency allowing the core boxes to be filled and packed quickly. Therefore, the system is ideal for automation and the mass production of cores. The disadvantage is that more sand and binder is used in this system than in the shell core system.

Warm Box Core

The warm box system is essentially the same as the hot box system, but uses a different catalyst. The catalysts used allow the resin binders to cure at a lower temperature (300 to 400 °F). As with the hot box, the resins used are phenolic and furan resins. Either copper salts or sulfonic acids are used as a catalyst. The advantage over hot box is reduced energy costs for heating (Twarog, 1993).

Cold Box

The cold box process is relatively new to the foundry industry. The system uses a catalytic gas to cure the binders at room temperature. A number of different systems are available including phenolic urethane binder with carbon dioxide gas as the catalyst. Other systems involve different binders (e.g., sodium silicate) and gases, such as sulfur dioxide and dimethylethylamine (DMEA), many of which are flammable or irritants. Compared to other chemical systems, the cold box systems have a short curing time (lower than ten seconds) and therefore are well suited to mass production techniques (AFS, 1981). In addition, the absence of costly oven heating can result in substantial energy savings.

No-Bake

The no-bake or air set binder systems allow curing at room temperature without the use of reactive gases. The no-bake system uses either acid catalysts or esters to cure the binder. The acid catalysts are typically benzene,

toluene, sulfonic or phosphoric acids. Binders are either phenolic resins, furan resins, sodium silicate solution or alkyd urethane. The system has the advantage of substantial savings in energy costs (Twarog, 1993).

Advantages and Disadvantages

Cores are necessarily constructed using chemical binders. Molds, however, may be constructed with chemical binders or green sand. The advantages to using chemically bonded molds over green sand molds may include: a longer storage life for the molds, a potentially lower metal pouring temperature, and molds having better dimensional stability and surface finish. Disadvantages include the added costs of chemical binders, the energy costs for curing the binders, added difficulties to reclaim used sand, and environmental and worker safety concerns for air emissions associated with binder chemicals during curing and metal pouring.

Wastes Generated

Solid wastes generated include broken cores and sand that has set up prematurely or inadequately. Waste resins and binders can be generated from spills, residuals in containers, and outdated materials. In addition to fugitive dust from the handling of sand, mold and core making using chemical binding systems may generate gaseous emissions such as carbon monoxide, VOCs and a number of gasses listed as hazardous air pollutants (HAPs) under the Clean Air Act. Emissions occur primarily during heating or curing of the molds and cores, removal of the cores from core boxes, cooling, and pouring of metal into molds (Twarog, 1993). The specific pollutants generated depends on the type of binding system being used. Section III.B Table 4 lists typical air emissions that may be expected from each major type of chemical binding system. Wastewater containing metals, suspended solids, and phenols may be generated if molds are cooled with water.

Permanent Mold Casting

In permanent mold casting, metal molds are used repeatedly. Although the molds deteriorate over time, they can be used to make thousands of castings before being replaced. The process is similar to die casting (see Section III.A.6 on Die Casting) with the exception being that gravity is used to fill the mold rather than external pressure. Permanent molds are designed to be opened, usually on a hinge, so that the castings can be removed. Permanent molds can be used for casting both ferrous and nonferrous metals as long as the mold metal has a higher melting point than the casting metal. Cores from permanent molds can be sand, plaster, collapsible metal or, soluble salts. When cores are not reusable, the process is often referred to as semipermanent mold casting (AFS, 1981).

Since the process is relatively simple after the mold has been fabricated, and since large numbers of castings are usually produced, permanent mold casting

is typically an automated process. The sequence of operations includes an initial cleaning of the mold followed by preheating and the spraying or brushing on of a mold coating. The coating serves the purpose of insulating the molten metal from the relatively cool, heat conducting mold metal. This allows the mold to be filled completely before the metal begins to solidify. The coatings also help produce good surface finish, act as a lubricant to facilitate casting removal, and allow any air in the mold to escape via space between the mold and coating. After coating, cores are then inserted and the mold is closed. The metal is poured and allowed to solidify before opening and ejecting the casting (LaRue, 1989).

Materials

Mold metals are typically made of cast iron. The molds can be very simple or can have a number of sophisticated features, such as ejector pins to remove castings, water cooling channels and sliding core pins. Coatings are typically mixtures of sodium silicate and either vermiculite, talc, clay or bentonite (AFS, 1981).

Advantages and Disadvantages

Permanent molds have the obvious advantage of not requiring the making of a new mold (and the associated time and expenses) for every casting. The elimination of the mold making process results in a more simple overall casting process, a cleaner work environment, and far less waste generation. Because molten metal cools and solidifies much faster in a permanent mold than in a sand mold, a more dense casting with better mechanical properties is obtained. The process can also produce castings with a high level of dimensional accuracy and good surface finish (AFS, 1981). One disadvantage is the high cost of tooling, which includes the initial cost of casting and machining the permanent mold. In addition, the shapes and sizes of castings are limited due to the impossibility of removing certain shapes from the molds (USITC, 1984).

Wastes Generated

Compared to sand casting operations, relatively little waste is generated in the permanent mold process. Some foundries force cool the hot permanent molds with water sprayed or flushed over the mold. The waste cooling water may pick up contaminants from the mold such as metals and mold coatings. Fugitive dust and waste sand or plaster are generated if cores are fabricated of sand or plaster, respectively. Waste coating material may also be generated during cleaning of the mold.

Plaster Mold Casting

The conventional plaster molding process is similar to the sand molding processes. In cope and drag flasks, a plaster slurry mix is poured over the pattern halves. When the plaster has set, the patterns are removed and the

mold halves are baked to remove any water (USITC, 1984). Since even small amounts of water will, when quickly heated during pouring, expand to steam and adversely affect the casting, drying is a critical step in plaster mold casting. Oven temperatures may be as high as 800°F for as long as 16 to 36 hours. As in the sand mold processes, the cores are inserted, and the dried mold halves are attached prior to pouring the molten metal. The plaster molds are destroyed during the shakeout process. Plaster or sand cores may be used in the process.

The conventional plaster molding process described here is the most common of a number of plaster mold casting processes in use. Other processes include the foamed plaster casting process, the Antioch casting process and the match plate pattern casting process (AFS, 1981).

Materials

The plasters used in plaster mold casting are very strong, hard gypsum (calcium sulfate) cements mixed with either fibrous talcs, finely ground silica, pumice stone, clay or graphite. Plaster mixtures may also be comprised of up to 50 percent sand (AFS, 1981).

Advantages and Disadvantages

The plaster mold process can produce castings with excellent surface detail, complex and intricate configurations, and high dimensional accuracy. Plaster mold castings are also light, typically under 20 pounds (USITC, 1994). The process is limited to nonferrous metals because ferrous metals will react with the sulfur in the gypsum, creating defects on the casting surface (AFS, 1981). Plaster mold casting is more expensive than sand casting, and has a longer process time from mold construction to metal pouring. The process is only used, therefore, when the desired results cannot be obtained through sand casting or when the finer detail and surface finish will result in substantial savings in machining costs.

Wastes Generated

Waste mold plaster and fugitive dust can be generated using this process. Waste sand can also be generated, depending on the type of cores used.

Investment/Lost Wax Casting

Investment casting processes use a pattern or replica that is consumed, or lost, from the mold material when heated. The mold-making process results in a one-piece destroyable mold. The most common type of investment casting, the lost wax process, uses patterns fabricated from wax. Plastic patterns, however, are also fairly common in investment casting.

The process begins with the production of a wax or plastic replica of the part. Replicas are usually mass produced by injecting the wax or plastic into a die

(metal mold) in a liquid or semi-liquid state. Replicas are attached to a gating system (sprue and runners) constructed of the same material to form a tree assembly (see Figure 6). The assembly is coated with a specially formulated heat resistant refractory slurry mixture which is allowed to harden around the wax or plastic assembly forming the mold (USITC, 1984).

In the investment *flask* casting method, the assembly is placed in a flask and then covered with a refractory slurry which is allowed to harden (see Figure 6). In the more common investment *shell* casting method, the assembly is dipped in a refractory slurry and sand is sifted onto the coated pattern assembly and allowed to harden. This process is repeated until the desired shell thickness is reached (LaRue, 1989). In both methods, the assembly is then melted out of the mold. Some investment casting foundries are able to recover the melted wax and reuse a portion in the pattern making process. The resulting mold assemblies are then heated to remove any residual pattern material and to further cure the binder system. The mold is then ready for the pouring of molten metal into the central sprue which will travel through the individual sprues and runners filling the mold.

Although normally not necessary, cores can be used in investment casting for complex interior shapes. The cores are inserted during the pattern making step. The cores are placed in the pattern die and pattern wax or plastic is injected around the core. After the pattern is removed from the die, the cores are removed. Cores used in investment casting are typically collapsible metal assemblies or soluble salt materials which can be leached out with water or a dilute hydrochloric acid solution.

In addition to the investment flask and shell mold casting methods described above, a number of methods have been developed which use reusable master patterns. These processes were developed to eliminate production of expendable patterns, one of the most costly and time-consuming steps in the casting process. One process, called the Shaw Process, uses a refractory slurry containing ethyl silicate. The slurry cures initially to a flexible gel which can be removed from the pattern in two halves. The flexible mold halves can then be further cured at high temperatures until a hard mold is formed ready for assembly and pouring (AFS, 1981).

Figure 6: Investment Flask and Shell Casting

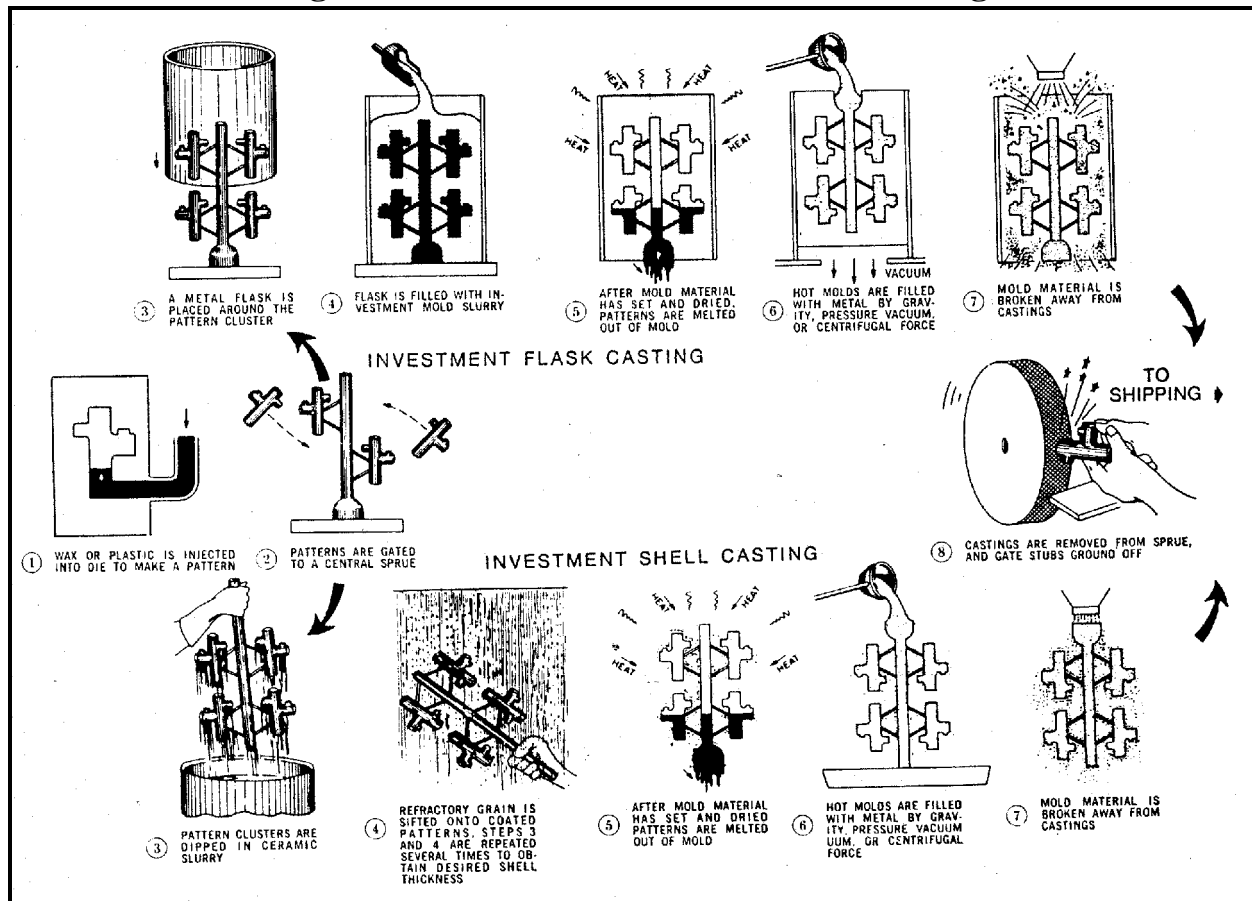

Source: American Foundrymen's Society, 1981.

Materials

The refractory slurries used in both investment flask and shell casting are comprised of binders and refractory materials. Refractory materials include silica, aluminum silicates, zircon, and alumina. Binders include silica sols (very small silica particles suspended in water), hydrolyzed ethyl silicate, sodium and potassium silicate, and gypsum type plasters. Ethyl silicate is typically hydrolyzed at the foundry by adding alcohol, water, and hydrochloric acid to the ethyl silicate as a catalyst (AFS, 1981).

Pattern materials are most commonly wax or polystyrene. Wax materials can be synthetic, natural, or a combination. Many different formulations are available with varying strengths, hardness, melting points, setting times, and compatibilities, depending on the specific casting requirements.

Advantages and Disadvantages

The investment casting process produces castings with a higher degree of dimensional accuracy than any other casting process. The process can also produce castings with a high level of detail and complexity and excellent surface finish. Investment casting is used to create both ferrous and nonferrous precision pieces such as dental crowns, fillings and dentures, jewelry, and scientific instruments. The costs of investment casting are generally higher than for other casting processes due in part to the high initial costs of pattern die-making (USITC, 1984). In addition, the relatively large number of steps in the process is less amenable to automation than many other casting methods.

Wastes Generated

Waste refractory material, waxes, and plastic are the largest volume wastes generated. Air emissions are primarily particulates. Wastewater with suspended and dissolved solids and low pH may also be generated if soluble salt cores are used.

Lost Foam Casting

The lost foam casting process, also known as Expanded Polystyrene (EPS) casting, and cavityless casting, is a relatively new process that is gaining increased use. The process is similar to investment casting in that an expendable polystyrene pattern is used to make a one-piece expendable mold. As in investment casting, gating systems are attached to the patterns, and the assembly is coated with a specially formulated gas permeable refractory slurry. When the refractory slurry has hardened, the assembly is positioned in a flask, and unbonded sand is poured around the mold and compacted into any internal cavities. Molten metal is then poured into the polystyrene pattern which vaporizes and is replaced by the metal (see Figure 7). When the metal has solidified, the flask is emptied onto a steel grate for shakeout. The loose sand falls through the grate and can be reused without treatment. The refractory material is broken away from the casting in the usual manner (AFS, 1981).

Materials

Refractory slurries for lost foam casting must produce a coating strong enough to prevent the loose sand around the coated assembly from collapsing into the cavity as the pattern vaporizes. Coatings must also be permeable to allow the polystyrene vapors to escape from the mold cavity, through the coating, into the sand and out of the flask. Flasks for this process have side vents which allow the vapors to escape (AFS, 1981).

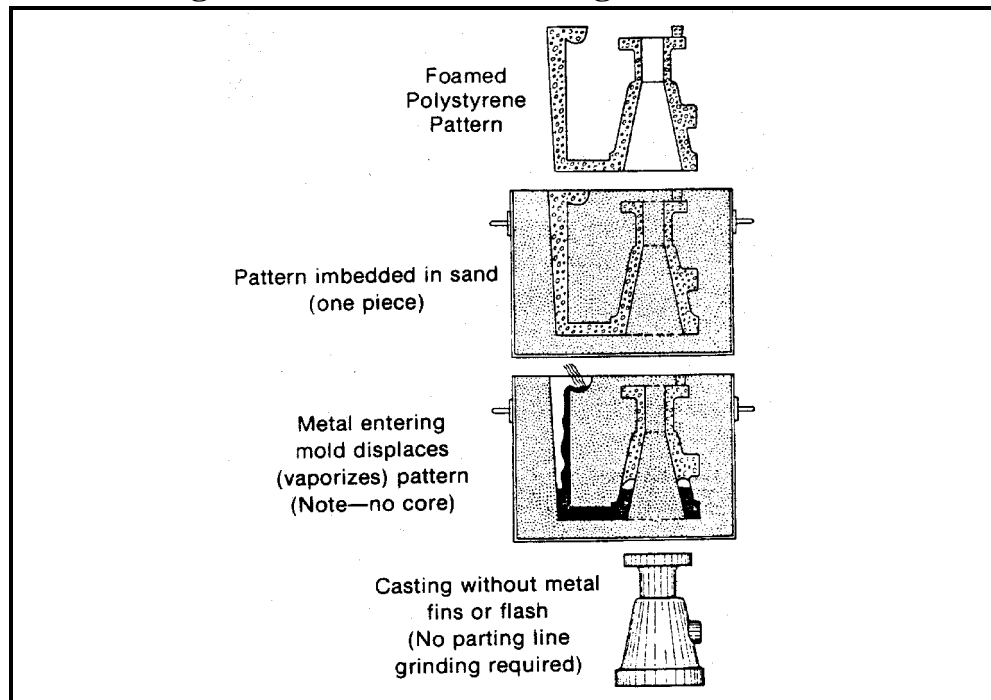
Figure 7: Lost Foam Casting Cross Sections

Source: American Foundrymen's Society, 1981.

Polystyrene patterns can be fabricated from polystyrene boards or by molding polystyrene beads. Patterns from boards are fabricated using normal pattern forming tools (see Section III.A.1). The boards are available in various sizes and thicknesses, and can be glued together to increase thickness if needed. Molded polystyrene patterns begin as small beads of expandable polystyrene product. The beads are pre-expanded to the required density using a vacuum, steam, or hot air processes. In general, the aim is to reduce the bead density as much as possible in order to minimize the volume of vapors to be vented during casting. If vapors are generated faster than can be vented, casting defects will result. The expanded polystyrene beads are blown into a cast aluminum mold. Steam is used to heat the beads causing them to expand further, fill void areas, and bond together. The mold and pattern are allowed to cool, and the pattern is ejected (AFS, 1981).

Advantages and Disadvantages

The lost foam process can be used for precision castings of ferrous and nonferrous metals of any size. In addition to being capable of producing highly accurate, complex castings with thin walls, good surface finish, and no parting lines, there are numerous practical advantages to the process. For example, there are far fewer steps involved in lost foam casting compared to sand casting. Core making and setting is not necessary, nor is the mixing of large amounts of sand and binders. Shakeout and sand handling is a matter

of pouring out the sand which is mostly reusable without any treatment since binders are not used. Some portion of sand may need to be removed to avoid the buildup of styrene in the sand. The flasks used are less expensive and easier to use since there are no cope and drag halves to be fastened together. The reduced labor and material costs make lost foam casting an economical alternative to many traditional casting methods. Although the potential exists for other metals to be cast, currently only aluminum and gray and ductile iron are cast using this method (AFS, 1981). In addition there are some limitations in using the technique to cast low carbon alloys (SFSA, 1997).

Wastes Generated

The large quantities of polystyrene vapors produced during lost foam casting can be flammable and may contain hazardous air pollutants (HAPs). Other possible air emissions are particulates related to the use of sand. Waste sand and refractory materials containing styrene may also be generated.

III.A.3. Furnace Charge Preparation and Metal Melting

Foundries typically use recycled scrap metals as their primary source of metal, and use metal ingot as a secondary source when scrap is not available. The first step in metal melting is preparation of the scrap materials. Preparation, which also may be done by the foundry's metal supplier, consists of cutting the materials to the proper size for the furnace and cleaning and degreasing the materials. Cleaning and degreasing can be accomplished with solvents or by a precombustion step to burn off any organic contaminants (Kotzin, 1992). Prepared scrap metal is weighed and additional metal, alloys, and flux may be added prior to adding the metal to the furnace. Adding metal to a furnace is called "charging." (Alloys may also be added at various stages of the melt or as the ladle is filled.)

Flux is a material added to the furnace charge or to the molten metal to remove impurities. Flux unites with impurities to form dross or slag, which rises to the surface of the molten metal where it is removed before pouring (LaRue, 1989). The slag material on the molten metal surface helps to prevent oxidation of the metal. Flux is often chloride or fluoride salts that have an affinity to bind with certain contaminants. The use of salt fluxes may result in emissions of acid gasses.

Five types of furnaces are commonly used to melt metal in foundries: cupola, electric arc, reverberatory, induction and crucible (see Figure 8). Some foundries operate more than one type of furnace and may even transfer molten metal between furnace types in order to make best use of the best features of each.

Cupola Furnaces

The cupola furnace is primarily used to melt gray, malleable, or ductile iron. The furnace is a hollow vertical cylinder on legs and lined with refractory material. Hinged doors at the bottom allow the furnace to be emptied when not in use. When charging the furnace, the doors are closed and a bed of sand is placed at the bottom of the furnace, covering the doors. Alternating layers of coke for fuel and scrap metal, alloys and flux are placed over the sand. Although air, or oxygen enriched air, is forced through the layers with a blower, cupolas require a reducing atmosphere to maintain the coke bed. Heat from the burning coke melts the scrap metal and flux, which drip to the bottom sand layer. In addition, the burning of coke under reducing conditions raises the carbon content of the metal charge to the casting specifications. A hole level with the top of the sand allows molten metal to be drained off, or “tapped.” A higher hole allows slag to be drawn off. Additional charges can be added to the furnace as needed (LaRue, 1989).

Electric Arc Furnaces

Electric arc furnaces are used for melting cast iron or steel. The furnace consists of a saucer-shaped hearth of refractory material for collecting the molten metal with refractory material lining the sides and top of the furnace. Two or three carbon electrodes penetrate the furnace from the top or sides. The scrap metal charge is placed on the hearth and melted by the heat from an electric arc formed between the electrodes. When the electric arc comes into contact with the metal, it is a direct-arc furnace and when the electric arc does not actually touch the metal it is an indirect-arc furnace. Molten metal is typically drawn off through a spout by tipping the furnace. Alloying metal can be added, and slag can be removed, through doors in the walls of the furnace (LaRue, 1989). Electric arc furnaces have the advantage of not requiring incoming scrap to be clean. One disadvantage is that they do not allow precise metallurgical adjustments to the molten metal.

Reverberatory Furnaces

Reverberatory furnaces are primarily used to melt large quantities of nonferrous metals. Metal is placed on a saucer-shaped hearth lined with refractory material on all sides. Hot air and combustion gasses from oil or gas burners are blown over the metal and exhausted out of the furnace. The heat melts the metal and more charge is added until the level of molten metal is high enough to run out of a spout in the hearth and into a well from which it can be ladled out (LaRue, 1989).

Induction Furnaces

Induction furnaces are used to melt both ferrous and non-ferrous metals. There are several types of induction furnaces, but all create a strong magnetic field by passing an electric current through a coil wrapped around the furnace. The magnetic field in turn creates a voltage across and subsequently an electric current through the metal to be melted. The electrical resistance of the metal produces heat which melts the metal. Induction furnaces are very

efficient and are made in a wide range of sizes (LaRue, 1989). Induction furnaces require cleaner scrap than electric arc furnaces, however, they do allow precise metallurgical adjustments.

Crucible Furnaces

Crucible furnaces are primarily used to melt smaller amounts of nonferrous metals than other furnace types. The crucible or refractory container is heated in a furnace fired with natural gas or liquid propane. The metal in the crucible melts, and can be ladled from the crucible or poured directly by tipping the crucible (LaRue, 1989).

Wastes Generated

Cupola, reverberatory and electric arc furnaces may emit particulate matter, carbon monoxide, hydrocarbons, sulfur dioxide, nitrogen oxides, small quantities of chloride and fluoride compounds, and metallic fumes from the condensation of volatilized metal and metal oxides. Induction furnaces and crucible furnaces emit relatively small amounts of particulates, hydrocarbons, and carbon monoxide emissions. The highest concentration of furnace emissions occur when furnaces are opened for charging, alloying, slag removal, and tapping (Kotzin, 1992). Particulate emissions can be especially high during alloying and the introduction of additives. For example, if magnesium is added to molten metal to produce ductile iron, a strong reaction ensues, with the potential to release magnesium oxides and metallic fumes (NADCA, 1996).

Furnace emissions are often controlled with wet scrubbers. Wet scrubber wastewater can be generated in large quantities (up to 3,000 gallons per minute) in facilities using large cupola furnaces. This water may contain metals and phenols, and is typically highly alkaline or acidic and is neutralized before being discharged to the POTW (AFS Air Quality Committee, 1992). Non-contact cooling water with little or no contamination may also be generated.

Scrap preparation using thermal treatment will emit smoke, organic compounds and carbon monoxide. Other wastes may include waste solvents if solvents are used to prepare metal for charging. Slag is also generated during metal melting operations. Hazardous slag can be generated if the charge materials contain enough toxic metals such as lead and chromium or if calcium carbide is used in the metal to remove sulfur compounds (see Section III.B.1) (U.S. EPA, 1992).

Figure 8: Sectional Views of Melting Furnaces

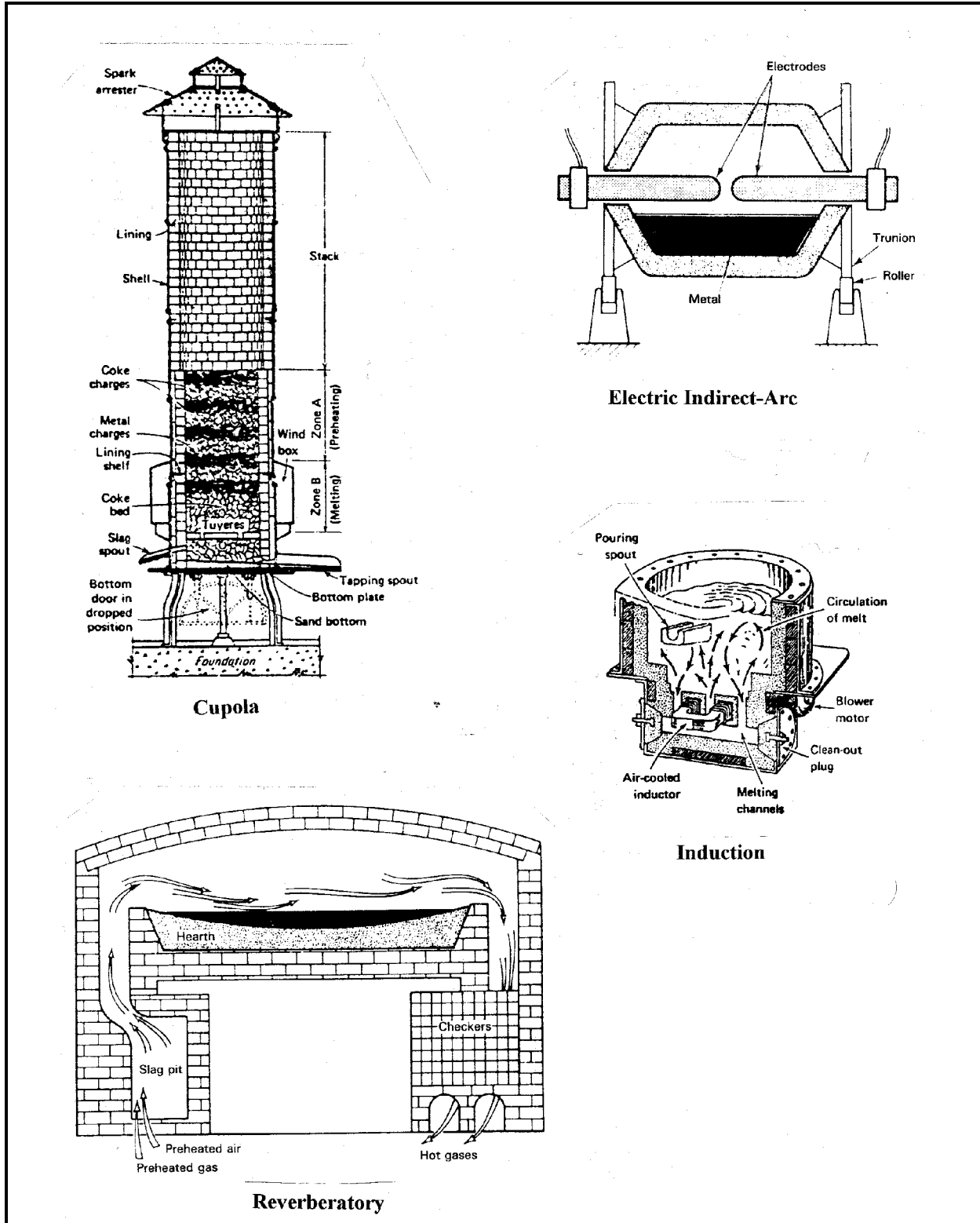

Electric Indirect-Arc

Induction

Cupola

Reverberatory

Source: American Foundrymen's Society, 1989.

III.A.4. Shakeout, Cooling and Sand Handling

For those foundries using sand molding and core making techniques, castings need to be cooled and separated from the sand mold. After molten metal has been ladled into the mold and begins to solidify, it is transported to a cooling area where the casting solidifies before being separated from the mold. Larger, more mechanized foundries use automatic conveyor systems to transfer the casting and mold through a cooling tunnel on the way to the shakeout area. Less mechanized foundries allow the castings to cool on the shop floor. In the shakeout area, molds are typically placed on vibrating grids or conveyors to shake the sand loose from the casting. In some foundries, the mold may be separated from the casting manually (EPA, 1986).

Sand casting techniques can generate substantial volumes of waste sand. Many foundries reuse a large portion of this sand and only remove a small portion as waste. Waste sand removed from the foundry is primarily made up of fine grains that build up as the sand is reused over and over. Most foundries, therefore, have a large multi-step sand handling operation for capturing and conditioning the reusable sand. Larger foundries often have conveyORIZED sand-handling systems working continuously. Smaller, less mechanized foundries often use heavy equipment (e.g., front-end loaders) in a batch process (U.S. EPA, 1992). Increasingly, foundry waste sand is being sent off-site for use as a construction material (see Section V).

Sand handling operations receive sand directly from the shakeout step or from an intermediate sand storage area. A typical first step in sand handling is lump knockout. Sand lumps occur when the binders used in sand cores only partially degrade after exposure to the heat of molten metal. The lumps, or core butts, may be crushed and recycled into molding sand during this step. They can also be disposed as waste material. A magnetic separation operation is often used in ferrous foundries to remove pieces of metal from the sand. Other steps involve screening to remove fines that build up over time, and cooling by aeration. In addition, some foundries treat mold and core sand thermally to remove binders and organic impurities (U.S. EPA, 1992).

Wastes Generated

Shakeout, cooling, and sand handling operations generate waste sand and fines possibly containing metals. In addition, particulate emissions are generated during these operations. If thermal treatment units are used to reclaim chemically bonded sands, emissions such as carbon monoxide, organic compounds, and other gasses can be expected.

III.A.5. Quenching, Finishing, Cleaning and Coating

Rapid cooling of hot castings by quenching in a water bath is practiced by some foundries and die casters to cool and solidify the casting rapidly (to speed the process) and to achieve certain metallurgical properties. The water bath may be plain water or may contain chemical additives to prevent oxidation.

Some amount of finishing and cleaning is required for all castings; however, the degree and specific types of operations will depend largely on the casting specifications and the casting process used. Finishing and cleaning operations can be a significant portion of the overall cost to produce a casting. Foundries, therefore, often search for casting techniques and mold designs that will reduce the finishing needed.

Finishing operations begin once the casting is shaken out and cooled. Hammers, band saws, abrasive cutting wheels, flame cut-off devices, and air-carbon arc devices may be used to remove the risers, runners, and sprues of the gating system. Metal fins at the parting lines (lines on a casting corresponding to the interface between the cope and drag of a mold) are removed with chipping hammers and grinders. Residual refractory material and oxides are typically removed by sand blasting or steel shot blasting, which can also be used to give the casting a uniform and more attractive surface appearance (U.S. EPA, 1992).

The cleaning of castings precedes any coating operations to ensure that the coating will adhere to the metal. Chemical cleaning and coating operations are often contracted out to off-site firms, but are sometimes carried out at the foundries. Scale, rust, oxides, oil, grease, and dirt can be chemically removed from the surface using organic solvents (typically chlorinated solvents, although naphtha, methanol, and toluene are also used), emulsifiers, pressurized water, abrasives, alkaline agents (caustic soda, soda ash, alkaline silicates, and phosphates), or acid pickling. The pickling process involves the cleaning of the metal surface with inorganic acids such as hydrochloric acid, sulfuric acid, or nitric acid. Castings generally pass from the pickling bath through a series of rinses. Molten salt baths are also used to clean complex interior passages in castings (U.S. EPA, 1992).

Castings are often given a coating to inhibit oxidation, resist deterioration, or improve appearance. Common coating operations include: painting, electroplating, electroless nickel plating, hard facing, hot dipping, thermal spraying, diffusion, conversion, porcelain enameling, and organic or fused dry-resin coating (U.S. EPA, 1992).

Wastes Generated

Casting quench water may contain phenols, oil and grease, suspended solids, and metals (e.g., copper, lead, zinc). Metal-bearing sludges may be generated when quench baths are cleaned out (EPA, 1995).

Finishing operations may generate particulate air emissions. Wastewater may contain cutting oils, ethylene glycol, and metals. Solid wastes include metal chips and spent cutting oils (EPA, 1995).

Cleaning and coating may generate air emissions of VOCs from painting, coating and solvent cleaning; acid mists and metal ion mists from anodizing, plating, polishing, hot dip coating, etching, and chemical conversion coating. Wastewater may contain solvents, metals, metal salts, cyanides, and high or low pH. Solid wastes include cyanide and metal-bearing sludges, spent solvents and paints, and spent plating baths (EPA, 1995).

III.A.6. Die Casting

The term “die casting” usually implies “pressure die casting.” The process utilizes a permanent die (metal mold) in which molten metal is forced under high pressure. Dies are usually made from two blocks of steel, each containing part of the cavity, which are locked together while the casting is being made. Retractable and removable cores are used to form internal surfaces. The metal is held under pressure until it cools and solidifies. The die halves are then opened and the casting is removed, usually by means of an automatic ejection system. Dies are preheated and lubricated before being used, and are either air- or water-cooled to maintain the desired operating temperature (Loper, 1985). Metal is typically melted on site from prealloyed ingot, or by blending the alloying constituents (or occasionally metal scrap). Some aluminum die casters, however, purchase molten aluminum and store it on site in a holding furnace (NADCA, 1996). Two basic types of die casting machines are used: hot chamber and cold-chamber (see Figure 9).

Die casting machines

Hot-chamber die casting machines are comprised of a molten metal reservoir, the die, and a metal-transferring device which automatically withdraws molten metal from the reservoir and forces it under pressure into the die. A steel piston and cylinder system is often used to create the necessary pressure within the die. Pressures can range from a few hundred to over 5,000 psi. Certain metals, such as aluminum alloys, zinc alloys, and pure zinc cannot be used in hot-chamber die casting because they rapidly attack the iron in the piston and cylinder. These metals, therefore, require a different type of casting machine, called a gooseneck. A gooseneck machine utilizes a cast-iron channel to transfer the molten metal from the reservoir to the die (see Figure 9(b)). After the gooseneck is brought into contact with the die, compressed air is applied to the molten metal. Pressures are typically in the range of 350 to 500 psi (Loper, 1985).

Cold chamber machines have molten metal reservoirs separate from the casting machine. Just enough metal for one casting is ladled by hand or mechanically into a small chamber, from which it is forced into the die under high pressure (see Figure 9(a)). Pressure is produced through a hydraulic system connected to a piston, and is typically in the range of a few thousand psi to 10,000 psi. In cold chamber machines, the metal is just above the melting point and is in a slush-like state. Since the metal is in contact with the piston and cylinder for only a short period of time, the process is applicable to aluminum alloys, magnesium alloys, zinc alloys, and even high melting-point alloys such as brasses and bronzes (Loper, 1985).

Figure 9: Cold (a), and Hot Chamber (b), Die Casting Machines

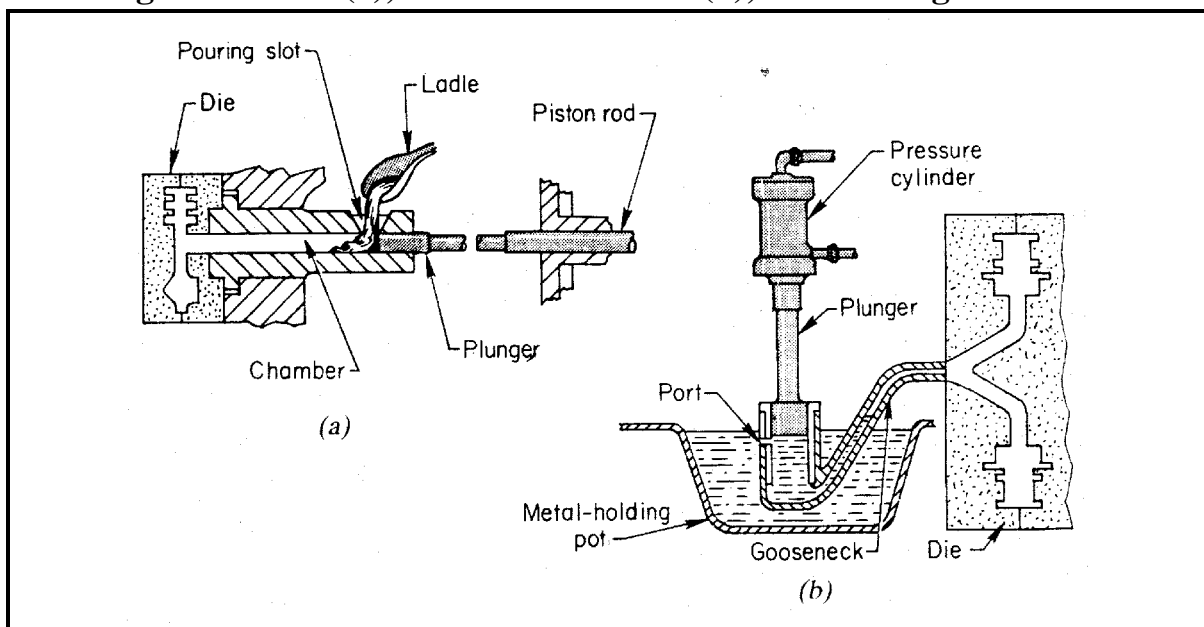

Source: American Foundrymen's Society, 1981.

Die Lubrication

Proper lubrication of dies and plungers is essential for successful die casting. Die lubrication affects the casting quality, density, and surface finish, the ease of cavity fill, and the ease of casting ejection. Proper lubrication can also speed the casting rate, reduce maintenance, and reduce build up of material on the die face (Street, 1977).

Die lubrication can be manual or automatic. In manual systems, the die casting machine operator uses a hand held spray gun to apply lubricant to the die surface just before the die is closed. Automatic systems use either fixed or reciprocating spray systems to apply lubricant (Allsop, 1983).

There are many types and formulations of lubricants on the market. No one

lubricant meets the requirements for all die casters. The specific lubricant formulation used depends on a number of factors, including: the metal being cast, the temperatures of casting, the lubricant application method, the surface finish requirements, the complexity of the casting, and the type of ejection system. Although specific formulations are proprietary, in general, lubricants are a mixture of a lubricant and a carrier material. Formulations may also include additives to inhibit corrosion, increase stability during storage, and resist bacterial degradation (Kaye, 1982).

Lubricants are mostly carrier material which evaporates upon contact with the hot die surface, depositing a thin uniform coating of die lubricant on the die face. Typical ratios of carrier to lubricant are about 40 to 1 (Kaye, 1982).

Both water-based lubricants and solvent-based lubricants are in use today. Solvents, however, are largely being phased out due to health and fire concerns associated with the large amounts of solvent vapors released. Water-based lubricants are now used almost exclusively in the U.S. Lubricating materials are typically mineral oils and waxes in water emulsions. Silicone oils and synthetic waxes are finding increased use. In addition, research is under way to develop a permanent release coating for die surfaces which will eliminate the need for repeated lubricant application (Kaye, 1982).

Advantages and Disadvantages

Die casting is not applicable to steel and high melting point alloys. Pressure dies are very expensive to design and produce, and the die casting machines themselves are major capital investments (LaRue, 1989). Therefore, to compete with other casting methods, it must be more economical to produce a component by virtue of higher production rates, or the finished components must be superior to those produced using other methods -- often, it is a combination of both factors (USITC, 1984).

Once the reusable die has been prepared, the die casting process can sustain very high production rates. Castings can be made at rates of more than 400 per hour. There is a limit, however, to the number of castings produced in a single die depending on the die design, the alloys being casted, and the dimensional tolerances required. The useable life span of a die can range from under 1,000 to over 5,000,000 castings or "shots." (Allsop, 1983) Therefore, the design of the die itself is critical not only for producing high quality castings but also in ensuring the economic viability of the production process. Die design is a very complex exercise. In addition to the design of the component geometry and constituent materials, numerous factors related to the die itself must be considered, including: the type of alloys, the temperature gradients within the die, the pressure and velocity of the molten metal when it enters the die, the technique for ejecting the casting from the die, and the lubrication system used (Street, 1977). Computer-aided design and modeling of die designs is now commonplace and has played an important role in

advancing the technology.

One major advantage of die casting over other casting methods is that the produced castings can have very complex shapes. The ability to cast complex shapes often makes it possible to manufacture a product from a single casting instead of from an assembly of cast components. This can greatly reduce casting costs as well as costs associated with fabrication and machining. Furthermore, die casting produces castings having a high degree of dimensional accuracy and surface definition compared to other casting methods, which may also reduce or eliminate costly machining steps. Finally, castings with relatively thin wall sections can be produced using the die casting method. This can result in substantial savings in material costs and reductions in component weight (Allsop, 1983).

Wastes Generated

Wastes generated during metal melting will be similar to those of metal melting in foundries, depending on the particular furnace used. Relatively little waste is generated in the actual die casting process compared to other metal casting processes. However, some gaseous and fume emissions occur during metal injection. Metal oxide fumes are released as some of the metal vaporizes and condenses. Gaseous emissions can originate from: the molten metal itself; the evolution of chemicals from the lubricant as it is sprayed onto the hot metal die; and as the molten metal contacts the lubricant (NADCA, 1996).

III.B. Raw Materials Inputs and Pollution Outputs

Raw material inputs and pollutant outputs differ for foundries and die casters. The major difference lies in the use of permanent molds by die casting facilities which eliminates any need for large mold making operations and the handling, treatment and disposal of sand and other refractory materials. For this reason, the material inputs and pollutant outputs of permanent mold casting foundries will likely be more similar to those of die casting facilities. Table 4 summarizes the material inputs and pollution outputs discussed in this section.

III.B.1. Foundries

The main raw material inputs for foundries are sand and other core and mold refractory materials (depending of the particular processes used), metals in the form of scrap and ingot, alloys, and fuel for metal melting. Other raw material inputs include binders, fluxing agents, and pattern making materials.

Air Emissions

Air emissions at foundries primarily arise from metal melting, mold and core making, shakeout and sand handling, and the cleaning and finishing of cast parts (Kotzin, 1992).

Furnaces and Metal Melting

Furnace air emissions consist of the products of combustion from the fuel and particulate matter in the form of dusts, metallics, and metal oxide fumes. Carbon monoxide and organic vapors may also arise if oily scrap is charged to the furnace or preheat system (AP-42, 1993). Particulates will vary according to the type of furnace, fuel (if used), metal melted, melting temperature, and a number of operating practices. Air emissions from furnaces and molten metal can often be reduced by applying a number of good operating practices (see Section V.A). Particulates can include fly ash, carbon, metallic dusts, and fumes from the volatilization and condensation of molten metal oxides. In steel foundries, these particulates may contain varying amounts of zinc, lead, nickel, cadmium, and chromium (Kotzin, 1992). Carbon-steel dust can be high in zinc as a result of the use of galvanized scrap, while stainless steel dust is high in nickel and chromium. Painted scrap can result in particulates high in lead. Particulates associated with nonferrous metal production may contain copper, aluminum, lead, tin, and zinc. The particulate sizes of the oxide fumes are often very small (submicron) and, therefore, require high efficiency control devices (Licht, 1992).

Furnace air emissions are typically captured in ventilation systems comprised

of hoods and duct work. Hoods and ducts are usually placed over and/or near the tapping spouts, and metal charging, slag removal, and pouring areas. Hoods can be permanently fixed at pouring stations or attached to the pouring ladle or crane through flexible duct work. Depending on the type of furnace and metals melted, these ventilation systems may be ducted to coolers to cool the hot combustion gases, followed by baghouses, electrostatic precipitators and/or wet scrubbers to collect particulates. Afterburners may also be used to control carbon monoxide and oil vapors (Licht, 1992).

Mold and Core Making

The major air pollutants generated during mold and core making are particulates from the handling of sand and other refractory materials, and VOCs from the core and mold curing and drying operations. VOCs, particulates, carbon monoxide, and other organic compounds are also emitted when the mold and core come into contact with the molten metal and while the filled molds are cooled (AP-42, 1993).

The use of organic chemical binding systems (e.g., cold box, hot box, no bake, etc.) may generate sulfur dioxide, ammonia, hydrogen sulfide, hydrogen cyanide, nitrogen oxides and large number of different organic compounds. Emissions occur primarily during heating and curing, removal of the cores from core boxes, cooling, and pouring the metal into molds and may include a number of gases listed as hazardous air pollutants (HAPs) under the Clean Air Act. Potential HAPs emitted when using chemical binding systems include: formaldehyde, methylene diphenyl diisocyanate (MDI), phenol, triethylamine, methanol, benzene, toluene, cresol/cresylic acid, naphthalene, polycyclic-organics, and cyanide compounds (Twarog, 1993).

Some core-making processes use strongly acidic or basic substances for scrubbing the off gasses from the core making process. In the free radical cure process, acrylic-epoxy binders are cured using an organic hydroperoxide and SO₂ gas. Gasses are typically scrubbed to remove sulfur dioxide before release through the stack to the atmosphere. A wet scrubbing unit absorbs the SO₂ gas. A 5 to 10 percent solution of sodium hydroxide at a pH of 8 to 14 neutralizes the SO₂ and prevents the by-product (sodium sulfite) from precipitating out of solution (U.S. EPA, 1992).

Amine scrubbers may be used for sulfur dioxide control by foundries. In amine scrubbing the gas containing sulfur dioxide is first passed through a catalyst bed, where the sulfur compounds are converted to hydrogen sulfide. The gas stream then enters a packed or trayed tower (scrubber) where it is contacted with a solution of water and an organic amine. The amine solution is alkaline and the weakly acidic hydrogen sulfide in the gas stream dissolves in it. The amine solution with hydrogen sulfide is then sent to a stripping tower, where it is boiled and the acid gases stripped out. The amine solution is cooled and returned to the scrubbing tower for reuse. Acid gases are

cooled and treated through neutralization. A number of amines are used including diethanolamine (DEA), monoethanolamine (MEA), and methyldiethanolamine (MDEA). Air emissions from the amine scrubbers may include some H₂S and other sulfur compounds. (Scott, 1992).

Shakeout, Finishing, and Sand Handling

Shakeout and sand handling operations generate dust and metallic particulates. Finishing and cleaning operations will generate metallic particulates from deburring, grinding, sanding and brushing, and volatile organic compounds from the application of rust inhibitors or organic coatings such as paint. Control systems involve hoods and ducts at key dust generating points followed by baghouses, electrostatic precipitators, or wet scrubbers (AFS Air Quality Committee, 1992).

Wastewater

Wastewater mainly consists of noncontact cooling water and wet scrubber effluent (Leidel, 1995). Noncontact cooling water can typically be discharged to the POTW or to surface waters under an NPDES permit. Wet scrubber wastewater in facilities using large cupola furnaces can be generated in large quantities (up to 3,000 gallons per minute). This water is typically highly alkaline or acidic and is neutralized before being discharged to the POTW (AFS Air Quality Committee, 1992). If amine scrubbers are used, amine scrubbing solution can be released to the plant effluent system through leaks and spills. Some foundries using cupola furnaces also generate wastewater containing metals from cooling slag with water. Wastewater may also be generated in certain finishing operations such as quenching and deburring. Such wastewater can be high in oil and suspended solids (NADCA, 1996).

Residual Wastes

Residual wastes originate from many different points within foundries. Waste sand is by far the largest volume waste for the industry. Other residual wastes may include dust from dust collection systems, slag, spent investment casting refractory material, off-spec products, resins, spent solvents and cleaners, paints, and other miscellaneous wastes.

Furnaces and Metal Melting

The percentage of metal from each charge that is converted to dust or fumes and collected by baghouses, electrostatic precipitators, or wet scrubbers can vary significantly from facility to facility depending on the type of furnace used and the type of metal cast. In steel foundries, this dust contains varying amounts of zinc, lead, nickel, cadmium, and chromium. Carbon-steel dust tends to be high in zinc as a result of the use of galvanized scrap, while stainless steel dust is high in nickel and chromium. Dust high in lead may result from the use of scrap painted with leaded paint. Dust associated with

nonferrous metal production may contain copper, aluminum, lead, tin, and zinc. Steel dust may be encapsulated and disposed of in a permitted landfill, while nonferrous dust is often sent to a recycler for metal recovery.

Slag is a glassy mass with a complex chemical structure. It can constitute about 25 percent of a foundry's solid waste stream (Kotzin, 1995). Slag is composed of metal oxides from the melting process, melted refractories, sand, coke ash (if coke is used), and other materials. Large quantities of slag are generated in particular from iron foundries that melt in cupola furnaces. Fluxes are used to facilitate removal of contaminants from the molten metal into the slag so that it can be removed from the molten metal surface. Hazardous slag may be produced in melting operations if the charge materials contain toxic metals such as lead, cadmium, or chromium. To produce ductile iron by reducing the sulfur content of iron, some foundries use calcium carbide desulfurization and the slag generated by this process may be classified as a reactive waste (U.S. EPA, 1992).

Mold and Core Making

Those core-making processes that use strongly acidic or basic substances for scrubbing the off gasses from the core making process may generate sludges or liquors. These sludges or liquors are typically pH controlled prior to discharge to the sewer system as nonhazardous waste. If not properly treated, the waste may be classified as hazardous corrosive waste and thus subjected to numerous federal, state and local mandates (U.S. EPA, 1992).

Shakeout and Sand Handling

Foundries using sand molds and cores generate large volumes of waste sands. Waste foundry sand can account for 65 to 90 percent of the total waste generated by foundries. In many foundries, casting sands are recycled internally until they can no longer be used. Some foundries reclaim waste sands so that they can be recycled to the process or recycled off-site for another use (see Section V.A.1). Sand that can no longer be used by iron or steel foundries, is often landfilled as nonhazardous waste. Casting sands used in the production of brass or bronze castings may exhibit toxicity characteristic for lead or cadmium. The hazardous sand may be reclaimed in a thermal treatment unit which may be subject to RCRA requirements for hazardous waste incinerators (see Section VI.B) (U.S. EPA, 1992). Approximately two percent of all foundry spent sand is hazardous (Kotzin, 1995).

Investment casting shells can be used only once and are disposed in landfills as a nonhazardous waste unless condensates from heavy metal alloy constituents are present in the shells.

Most foundries generate miscellaneous residual waste that varies greatly in composition, but makes up only a small percentage of the total waste. This waste includes welding materials, waste oil from heavy equipment and hydraulics, empty binder drums, and scrubber lime (U.S. EPA, 1992).

III.B.2. Die Casters

The main raw material inputs for die casters include: metal in the form of ingot, molten metal, metal scrap, alloys, and fuel for metal melting. Other raw material inputs include: fluxing agents, die lubricants, refractory materials, hydraulic fluid, and finishing and cleaning materials.

Air Emissions

Furnace air emissions consist of the products of combustion from the fuel and particulate matter in the form of dusts, metallics, and metal oxide fumes. Carbon monoxide and oil vapors may also arise if oily scrap is charged to the furnace or preheat system. Metallic particulates arise mainly from the volatilization and condensation of molten metal oxides. These will vary according to the type of furnace, fuel, metal, melting temperature, and a number of operating practices. The particulate sizes of the oxide fumes are often very small (submicron) and may contain copper, aluminum, lead, tin, and zinc (Licht, 1992).

Fluxing and dross removal operations to remove impurities from the molten metal can also be the source of air emissions. Die casters can use a number of different fluxing agents to remove different impurities, including: sulfur hexafluoride, solvent fluxes, aluminum fluoride, or chlorine. Metallic particulates, the fluxing agents themselves, and products of chemical reactions with impurities can be emitted from the molten metal surface or from the subsequently removed dross as it cools. For example, if chlorine is used, it may react with aluminum and water in the atmosphere to form aluminum oxide fumes and hydrochloric acid. Although not always necessary, particulate emissions control equipment, such as fabric bag filters, are sometimes used to control furnace emissions at die casting facilities (NADCA, 1996).

Die lubrication and plunger tip lubrication can also be a significant source of air releases from die casting facilities. Both oil- and water-based die lubricants are used. Oil-based lubricants typically contain naphtha and result in much higher emissions of volatile organic compounds than water-based lubricants. The air emissions will depend on the specific formulation of the

lubricant product and may contain hazardous air pollutants (NADCA, 1996).

Other air emissions arise from finishing and cleaning operations which generate metallic particulates from deburring, grinding, sanding and brushing, and volatile organic compounds from the application of rust inhibitors or paint. Casting quench tanks for the cooling of zinc castings can contain volatile organic compounds and water treatment chemicals resulting in potential emissions of volatile organic compounds and hazardous air pollutants (NADCA, 1996).

Wastewater

Both process wastewater and waste noncontact cooling water may be generated at die casting facilities. Noncontact cooling water will likely have elevated temperature and very little or no chemical contamination. Process wastewater from die casting facilities can be contaminated with spent die lubricants, hydraulic fluid and coolants. Contaminants in such wastewater are typically oil and phenols. As with foundries, die casters may also generate wastewater in certain finishing operations such as in-process cleaning, quenching and deburring. Such wastewater can be high in oil and suspended solids. Typical wastewater treatment at die casting facilities consists of oil/water separation and/or filtration before discharge to a POTW. Facilities generating large volumes of wastewater may also utilize biological treatment (NADCA, 1996).

Residual Wastes

Residual waste streams from die casting facilities are relatively small compared to most sand casting foundries. Typical residual wastes include: slag or dross generated from molten metal surfaces; refractory materials from furnaces and ladles; metallic fines, spent shot (plunger) tips, tools, heating coils, hydraulic fluid, floor absorbent, abrasive cutting belts and wheels, quench sludge, and steel shot. Most residual wastes from die casting facilities are sent off-site for disposal as a non-hazardous waste. Waste dross is usually sent to secondary smelters for metal recovery. Waste oils, lubricants and hydraulic fluids may be sent off-site for recycling or energy recovery (NADCA, 1996).

Table 4: Summary of Material Inputs and Potential Pollutant Outputs for the Metal Casting Industry				
Industrial Process	Material Inputs	Air Emissions	Wastewater	Residual Wastes
Pattern Making	Wood, plastic, metal, wax, polystyrene	VOCs from glues, epoxies, and paints.	Little or no wastewater generated	Scrap pattern materials
Mold and Core Preparation and Pouring				
Green Sand	Green sand and chemically-bonded sand cores	Particulates, metal oxide fumes, carbon monoxide, organic compounds, hydrogen sulfide, sulfur dioxide, and nitrous oxide. Also, benzene, phenols, and other hazardous air pollutants (HAPs) if chemically bonded cores are used.	Wastewater containing metals, elevated temperature, phenols and other organics from wet dust collection systems and mold cooling water	Waste green sand and core sand potentially containing metals
Chemical Binding Systems	Sand and chemical binders	Particulates, metallic oxide fumes, carbon monoxide, ammonia, hydrogen sulfide, hydrogen cyanide, sulfur dioxide, nitrogen oxides, and other HAPs	Scrubber wastewater with amines or high or low pH; and wastewater containing metals, elevated temperature, phenols and other organics from wet dust collection systems and mold cooling water	Waste mold and core sand potentially containing metals and residual chemical binders
Permanent Mold	Steel mold, permanent, sand, plaster, or salt cores	Particulates, metallic oxide fumes	Waste cooling water with elevated temperature and wastewater with low pH and high in dissolved salts if soluble salt cores are used	Waste core sand or plaster potentially containing metals
Plaster Mold	Plaster mold material	Particulates, metallic oxide fumes	Little or no wastewater generated	Spent plaster
Investment/Lost Wax	Refractory slurry, and wax or plastic	Particulates, metallic oxide fumes	Wastewater with low pH and high in dissolved salts if soluble salt cores are used	Waste refractory material, waxes and plastics

Industrial Process	Material Inputs	Air Emissions	Wastewater	Residual Wastes
Lost Foam	Refractory slurry, polystyrene	Particulates, metallic oxide fumes, polystyrene vapors and HAPs	Little or no wastewater generated	Waste sand and refractory material potentially containing metals and styrene
Furnace Charge Preparation and Metal Melting				
Charging and Melting	Metal scrap, ingot and returned castings	Products of combustion, oil vapors, particulates, metallic oxide fumes	Scrubber wastewater with high pH, slag cooling water with metals, and non-contact cooling water	Spent refractory material potentially containing metals and alloys
Fluxing and Slag and Dross Removal	Fluxing agents	Particulates, metallic oxide fumes, solvents, hydrochloric acid	Wastewater containing metals if slag quench is utilized	Dross and slag potentially containing metals
Pouring	Ladles and other refractory materials	Particulates, metallic oxide fumes	Little or no wastewater generated	Spent ladles and refractory materials potentially containing metals
Quenching, Finishing, Cleaning and Coating				
Painting and rust inhibitor application	Paint and rust inhibitor	VOCs	Little or no wastewater generated	Spent containers and applicators
Cleaning , quenching, grinding, cutting	Unfinished castings, water, steel shot, solvents	VOCs, dust and metallic particulates	Waste cleaning and cooling water with elevated temperature, solvents, oil and grease, and suspended solids	Spent solvents, steel shot, metallic particulates, cutting wheels, metallic filings, dust from collection systems, and wastewater treatment sludge
Shakeout, Cooling and Sand Handling	Water and caustic for wet scrubbers	Dust and metallic particulates; VOC and organic compounds from thermal sand treatment systems	Wet scrubber wastewater with high or low pH or amines, permanent mold contact cooling water with elevated temperature, metals and mold coating	Waste foundry sand and dust from collection systems, metal

Industrial Process	Material Inputs	Air Emissions	Wastewater	Residual Wastes
Die Casting¹	Metal, fuel, lubricants, fluxing agents, hydraulic fluid	VOCs from die and plunger tip lubrication	Waste cooling water with elevated temperature and wastewater contaminated with oil, and phenols	Waste hydraulic fluid, lubricants, floor absorbent, and plunger tips
¹ Furnaces, metal melting, finishing, cleaning, and coating operations also apply to die casting.				

III.C. Management of Chemicals in Wastestream

The Pollution Prevention Act of 1990 (PPA) requires facilities to report information about the management of Toxic Release Inventory (TRI) chemicals in waste and efforts made to eliminate or reduce those quantities. These data have been collected annually in Section 8 of the TRI reporting Form R beginning with the 1991 reporting year. The data summarized below cover the years 1993-1996 and are meant to provide a basic understanding of the quantities of waste handled by the industry, the methods typically used to manage this waste, and recent trends in these methods. TRI waste management data can be used to assess trends in source reduction within individual industries and facilities, and for specific TRI chemicals. This information could then be used as a tool in identifying opportunities for pollution prevention compliance assistance activities.

While the quantities reported for 1994 and 1995 are estimates of quantities already managed, the quantities listed by facilities for 1996 and 1997 are projections only. The PPA requires these projections to encourage facilities to consider future source reduction, not to establish any mandatory limits. Future-year estimates are not commitments that facilities reporting under TRI are required to meet.

Foundries

Table 5 shows that the TRI reporting foundries managed about 272 million pounds of production related wastes (total quantity of TRI chemicals in the waste from routine production operations in column B) in 1995. From the yearly data presented in column B, the total quantity of production related TRI wastes increased between 1994 and 1995. This is likely in part because the number of chemicals on the TRI list nearly doubled between those years. Production related wastes were projected to decrease in 1996 and 1997. The effects of production increases and decreases on the amount of wastes generated are not evaluated here.

Values in Column C are intended to reveal the percent of production-related waste (about 40 percent) either transferred off-site or released to the environment. Column C is calculated by dividing the total TRI transfers and releases by the total quantity of production-related waste. Column C shows a decrease in the amount of wastes either transferred off-site or released to the environment from 43 percent in 1994 to 40 percent in 1995. In other words, about 60 percent of the industry's TRI wastes were managed on-site through recycling, energy recovery, or treatment as shown in columns D, E, and F, respectively. Most of these on-site managed wastes were recycled on-site, typically in a metals recovery process. The majority of waste that is released or transferred off-site can be divided into portions that are recycled off-site, recovered for energy off-site, or treated off-site as shown in columns G, H,

and I, respectively. The remaining portion of the production related wastes (32 percent in 1994 and 1995), shown in column J, is either released to the environment through direct discharges to air, land, water, and underground injection, or is transferred off-site for disposal.

A Year	B Quantity of Production-Related Waste (10 ⁶ lbs.) ^a	C % Released and Transferred	On-Site			Off-Site			J % Released and Disposed ^c Off-site
			D	E	F	G	H	I	
			% Recycled	% Energy Recovery	% Treated	% Recycled	% Energy Recovery	% Treated	
1994	232	43%	58%	0%	1%	18%	0%	0%	32%
1995	272	40%	58%	0%	2%	16%	0%	1%	32%
1996	264	---	54%	0%	2%	20%	0%	1%	24%
1997	261	---	53%	0%	2%	21%	0%	1%	24%

Source: 1995 Toxics Release Inventory Database.

^a Within this industry sector, non-production related waste < 1% of production related wastes for 1995.

^b Total TRI transfers and releases as reported in Section 5 and 6 of Form R as a percentage of production related wastes.

^c Percentage of production related waste released to the environment and transferred off-site for disposal.

Die Casters

Table 6 shows that the TRI reporting foundries managed about 63 million pounds of production related wastes (total quantity of TRI chemicals in the waste from routine production operations) in 1995 (column B). Column C reveals that of this production-related waste, about 21 percent was either transferred off-site or released to the environment. Column C is calculated by dividing the total TRI transfers and releases by the total quantity of production-related waste. In other words, about 79% of the industry's TRI wastes were managed on-site through recycling, energy recovery, or treatment as shown in columns D, E, and F, respectively. Most of these on-site managed wastes were recycled on-site, typically in a metals recovery process. The majority of waste that is released or transferred off-site can be divided into portions that are recycled off-site, recovered for energy off-site, or treated off-site as shown in columns G, H, and I, respectively. The remaining portion of the production related wastes (2 percent in 1994), shown in column J, is either released to the environment through direct discharges to air, land, water, and underground injection, or it is disposed off-site.

Table 6: Source Reduction and Recycling Activity for Die Casting Facilities (SIC 3363 and 3364) as Reported within TRI									
A	B	C	On-Site			Off-Site			J
Year	Quantity of Production-Related Waste (10 ⁶ lbs.) ^a	% Released and Transferred ^b	D	E	F	G	H	I	% Released and Disposed ^c Off-site
			% Recycled	% Energy Recovery	% Treated	% Recycled	% Energy Recovery	% Treated	
1994	60	23%	69%	0%	3%	27%	0%	0%	2%
1995	63	21%	75%	0%	3%	21%	0%	0%	2%
1996	64	---	75%	0%	3%	21%	0%	0%	1%
1997	64	---	76%	0%	2%	21%	0%	0%	1%

Source: 1995 Toxics Release Inventory Database.

^a Within this industry sector, non-production related waste < 1% of production related wastes for 1995.

^b Total TRI transfers and releases as reported in Section 5 and 6 of Form R as a percentage of production related wastes.

^c Percentage of production related waste released to the environment and transferred off-site for disposal.

IV. CHEMICAL RELEASE AND TRANSFER PROFILE

This section is designed to provide background information on the pollutant releases that are reported by this industry. The best source of comparative pollutant release information is the Toxic Release Inventory (TRI). Pursuant to the Emergency Planning and Community Right-to-Know Act, TRI includes self-reported facility release and transfer data for over 600 toxic chemicals. Facilities within SIC Codes 20 through 39 (manufacturing industries) that have more than 10 employees, and that are above weight-based reporting thresholds are required to report TRI on-site releases and off-site transfers. The information presented within the sector notebooks is derived from the most recently available (1995) TRI reporting year (which includes over 600 chemicals), and focuses primarily on the on-site releases reported by each sector. Because TRI requires consistent reporting regardless of sector, it is an excellent tool for drawing comparisons across industries. TRI data provide the type, amount and media receptor of each chemical released or transferred.

Although this sector notebook does not present historical information regarding TRI chemical releases over time, please note that in general, toxic chemical releases have been declining. In fact, according to the 1995 Toxic Release Inventory Public Data Release, reported onsite releases of toxic chemicals to the environment decreased by 5 percent (85.4 million pounds) between 1994 and 1995 (not including chemicals added and removed from the TRI chemical list during this period). Reported releases dropped by 46 percent between 1988 and 1995. Reported transfers of TRI chemicals to off-site locations increased by 0.4 percent (11.6 million pounds) between 1994 and 1995. More detailed information can be obtained from EPA's annual Toxics Release Inventory Public Data Release book (which is available through the EPCRA Hotline at 800-535-0202), or directly from the Toxic Release Inventory System database (for user support call 202-260-1531).

Wherever possible, the sector notebooks present TRI data as the primary indicator of chemical release within each industrial category. TRI data provide the type, amount and media receptor of each chemical released or transferred. When other sources of pollutant release data have been obtained, these data have been included to augment the TRI information.

TRI Data Limitations

Certain limitations exist regarding TRI data. Release and transfer reporting are limited to the approximately 600 chemicals on the TRI list. Therefore, a large portion of the emissions from industrial facilities are not captured by TRI. Within some sectors, (e.g. dry cleaning, printing and transportation equipment cleaning) the majority of facilities are not subject to TRI reporting because they are not considered manufacturing industries, or because they are below TRI reporting thresholds. For these sectors, release information from other sources has been included. In addition, many facilities report more than one SIC code reflecting the multiple operations carried out onsite. Therefore,

reported releases and transfers may or may not all be associated with the industrial operations described in this notebook.

The reader should also be aware that TRI "pounds released" data presented within the notebooks is not equivalent to a "risk" ranking for each industry. Weighting each pound of release equally does not factor in the relative toxicity of each chemical that is released. The Agency is in the process of developing an approach to assign toxicological weightings to each chemical released so that one can differentiate between pollutants with significant differences in toxicity. As a preliminary indicator of the environmental impact of the industry's most commonly released chemicals, the notebook briefly summarizes the toxicological properties of the top five chemicals (by weight) reported by each industry.

Definitions Associated With Section IV Data Tables

General Definitions

SIC Code -- the Standard Industrial Classification (SIC) is a statistical classification standard used for all establishment-based Federal economic statistics. The SIC codes facilitate comparisons between facility and industry data.

TRI Facilities -- are manufacturing facilities that have 10 or more full-time employees and are above established chemical throughput thresholds. Manufacturing facilities are defined as facilities in Standard Industrial Classification primary codes 20-39. Facilities must submit estimates for all chemicals that are on the EPA's defined list and are above throughput thresholds.

Data Table Column Heading Definitions

The following definitions are based upon standard definitions developed by EPA's Toxic Release Inventory Program. The categories below represent the possible pollutant destinations that can be reported.

RELEASES -- are an on-site discharge of a toxic chemical to the environment. This includes emissions to the air, discharges to bodies of water, releases at the facility to land, as well as contained disposal into underground injection wells.

Releases to Air (Point and Fugitive Air Emissions) -- Include all air emissions from industry activity. Point emissions occur through confined air streams as found in stacks, vents, ducts, or pipes. Fugitive emissions include

equipment leaks, evaporative losses from surface impoundments and spills, and releases from building ventilation systems.

Releases to Water (Surface Water Discharges) -- encompass any releases going directly to streams, rivers, lakes, oceans, or other bodies of water. Releases due to runoff, including storm water runoff, are also reportable to TRI.

Releases to Land -- occur within the boundaries of the reporting facility. Releases to land include disposal of toxic chemicals in landfills, land treatment/application farming, surface impoundments, and other land disposal methods (such as spills, leaks, or waste piles).

Underground Injection -- is a contained release of a fluid into a subsurface well for the purpose of waste disposal. Wastes containing TRI chemicals are injected into either Class I wells or Class V wells. Class I wells are used to inject liquid hazardous wastes or dispose of industrial and municipal wastewater beneath the lowermost underground source of drinking water. Class V wells are generally used to inject non-hazardous fluid into or above an underground source of drinking water. TRI reporting does not currently distinguish between these two types of wells, although there are important differences in environmental impact between these two methods of injection.

TRANSFERS -- is a transfer of toxic chemicals in wastes to a facility that is geographically or physically separate from the facility reporting under TRI. Chemicals reported to TRI as transferred are sent to off-site facilities for the purpose of recycling, energy recovery, treatment, or disposal. The quantities reported represent a movement of the chemical away from the reporting facility. Except for off-site transfers for disposal, the reported quantities do not necessarily represent entry of the chemical into the environment.

Transfers to POTWs -- are wastewater transferred through pipes or sewers to a publicly owned treatment works (POTW). Treatment or removal of a chemical from the wastewater depend on the nature of the chemical, as well as the treatment methods present at the POTW. Not all TRI chemicals can be treated or removed by a POTW. Some chemicals, such as metals, may be removed, but are not destroyed and may be disposed of in landfills or discharged to receiving waters.

Transfers to Recycling -- are sent off-site for the purposes of regenerating or recovery by a variety of recycling methods, including solvent recovery, metals recovery, and acid regeneration. Once these chemicals have been recycled, they may be returned to the originating facility or sold commercially.

Transfers to Energy Recovery -- are wastes combusted off-site in industrial

furnaces for energy recovery. Treatment of a chemical by incineration is not considered to be energy recovery.

Transfers to Treatment -- are wastes moved off-site to be treated through a variety of methods, including neutralization, incineration, biological destruction, or physical separation. In some cases, the chemicals are not destroyed but prepared for further waste management.

Transfers to Disposal -- are wastes taken to another facility for disposal generally as a release to land or as an injection underground.

IV.A. EPA Toxic Release Inventory for the Metal Casting Industry

This section summarizes TRI data of ferrous and nonferrous foundries reporting SIC codes 332, 3365, 3366, and 3369, and ferrous and nonferrous die casting facilities reporting SIC codes 3363 and 3364 as the primary SIC code for the facility. Of the 2,813 metal casting establishments reported by the *1992 Census of Manufacturers*, 654 reported to TRI in 1995.

Ferrous and nonferrous foundries made up 85 percent (554 facilities) of metal casting facilities reporting to TRI and accounted for about 89 percent of the total metal casting TRI releases and transfers for metal casting facilities in 1995. Die casters made up 15 percent (100 facilities) of metal casting facilities and reported the remaining 11 percent of the total releases and transfers. Because the TRI information differs for foundries and die casters, the releases and transfers for these two industry segments are presented separately below.

IV.A.1. Toxic Release Inventory for Ferrous and Nonferrous Foundries

According to the 1995 TRI data, the reporting ferrous and nonferrous foundries released and transferred a total of approximately 109 million pounds of pollutants during calendar year 1995. These releases and transfers are dominated by large volumes of metallic wastes. Evidence of the diversity of processes at foundries reporting to TRI is found in the fact that the most frequently reported chemical (copper) is reported by only 45 percent of the facilities and over half of the TRI chemicals were reported by fewer than ten facilities. The variability in facilities' pollutant profiles may be attributable to the large number of different types of foundry processes and products. For example, foundries casting only ferrous parts will have different pollutant profiles than those foundries casting both ferrous and nonferrous products.

Releases

Releases to the air, water, and land accounted for 33 percent (36 million pounds) of foundries' total reportable chemicals. Of these releases, 70 percent go to onsite land disposal, and about 75 percent are fugitive or point source air emissions (See Table 7). Metallic wastes accounted for over 95 percent of the industry's releases. Manganese, zinc, chromium, and lead account for over 95 percent of the on-site land disposal. The industry's air releases are associated with volatilization, fume or aerosol formation in the furnaces and byproduct processing. Lighter weight organics, such as methanol, acids and metal contaminants found in scrap metal are the principal types of TRI chemicals released to the air. In addition to air releases of chemicals reported to TRI, foundries are often a source of particulates, carbon monoxide, nitrogen oxides and sulfur compounds due to sand handling operations, curing of chemical binders, and combustion of fossil fuels.

Methanol, trichloroethylene and other solvent releases account for most of the fugitive releases (approximately 61 percent).

Transfers

Off-site transfers of TRI chemicals account for 69 percent of foundries' total TRI-reportable chemicals (74 million pounds). Almost 57 percent of the industry's total TRI wastes (42 million pounds) are metallic wastes that were transferred off-site for recycling, typically for recovery of the metal content. Metallic wastes account for approximately 95 percent of the industry's transfers. About 61 percent of off-site transfers reported by foundries are sent off-site for recycling. Copper, manganese, zinc, chromium, nickel, and lead are the six metals transferred in the greatest amounts and number of facilities (See Table 8). TRI chemicals sent off-site for disposal (primarily manganese, zinc, chromium, and copper) account for 31 percent of transfers. Less than three percent of the remaining transfers from foundries go to treatment off-site, discharge to POTWs, and energy recovery.

After metals, the next largest volume of chemicals transferred are acids including: sulfuric acid, nitric acid, phosphoric acid, and hydrochloric acid. Spent acids can be generated in wet scrubber systems. In addition, acids are often used to clean and finish the surfaces of the metal castings before plating or coating. The spent acids are often sent off-site for recycling or for treatment. Solvents and other light weight organic compounds are frequently reported but account for a relatively small amount of total transfers. Solvents are used frequently for cleaning equipment and cast parts. The primary solvents and light weight organics include: phenol, xylene, 1,2,4-trimethylbenzene, 1,1,1-trichloroethane, trichloroethylene, methanol, and toluene. Transferred solvents are mostly sent off-site for disposal or recycling. Phenols and phenoisocyanates are frequently reported but amount to less than one percent of the total TRI pounds transferred. Phenols are often found in chemical binding systems and may be present in waste sand containing chemical binders (AFS and CISA, 1992).

**Table 7: 1995 TRI Releases for Foundries, by Number of Facilities Reporting
(Releases reported in pounds/year)**

CHEMICAL NAME	# REPORTING CHEMICAL	FUGITIVE AIR	POINT AIR	WATER DISCHARGES	UNDERGROUND INJECTION	LAND DISPOSAL	TOTAL RELEASES	AVG. RELEASES PER FACILITY
COPPER	249	78577	100548	4554	0	349835	533514	2143
NICKEL	182	23309	31804	1471	0	122406	178990	983
CHROMIUM	182	47389	33191	1653	0	162923	245156	1347
MANGANESE	179	163447	84164	3258	0	4891621	5142490	28729
PHENOL	89	219560	421803	4490	0	53891	699744	51996
LEAD	76	9671	24366	230	0	352489	386756	5089
DIISOCYANATES	65	12035	13152	260	0	9022	34469	530
MANGANESE COMPOUNDS	50	37530	63037	3020	0	2496212	2599799	
CHROMIUM COMPOUNDS	45	41903	70489	1529	0	779154	893075	19846
COPPER COMPOUNDS	36	14953	9020	517	0	65500	89990	2500
ZINC (FUME OR DUST)	35	71228	144470	2104	0	1696554	1914356	54696
NICKEL COMPOUNDS	32	12241	7188	512	0	724	20665	646
METHANOL	32	1952231	451245	7	0	0	2403483	75109
ZINC COMPOUNDS	31	40379	121541	2956	0	12733217	12898093	416068
ALUMINUM (FUME OR DUST)	31	40491	186471	259	0	792270	1019491	32887
TRIETHYLAMINE	30	235144	1143297	5	0	5	1378451	45948
PHOSPHORIC ACID	26	157071	578	10	0	86093	243752	9375
XYLENE (MIXED ISOMERS)	24	568145	284447	4	0	0	852596	35525
COBALT	24	1450	1832	501	0	5	3788	158
NAPHTHALENE	22	201461	104137	263	0	9481	315342	14334
MOLYBDENUM TRIOXIDE	22	2260	1755	275	0	2547	6837	311
1,2,4-TRIMETHYLBENZENE	18	188854	54393	1	0	32850	276098	15339
LEAD COMPOUNDS	16	5638	13160	579	0	221774	241151	15072
FORMALDEHYDE	16	75414	78441	245	0	11436	165536	10346
TOLUENE	13	334212	179171	20	0	14	513417	39494
BARIUM	13	34486	3691	135	0	141150	179462	13805
ALUMINUM OXIDE (FIBROUS FORMS)	11	82060	18828	250	0	592750	693888	63081
CERTAIN GLYCOL ETHERS	10	119511	85824	0	0	0	205335	20534
SULFURIC ACID	10	25739	510	5	0	0	26254	2625
NITRIC ACID	10	2685	7640	0	0	0	10325	1033
ETHYLENE GLYCOL	9	48835	14045	3	0	68000	130883	14543
HYDROCHLORIC ACID (1995 AND AFTER "ACID AEROSOLS" ONLY)	9	6	1604	0	0	0	1610	179
N-METHYL-2-PYRROLIDONE	8	86624	3520	5	0	482	90631	11329
AMMONIA	8	92708	325575	3002	0	0	421285	52661
1,1,1-TRICHLOROETHANE	7	182997	61382	0	0	0	244379	34911
BARIUM COMPOUNDS	6	23455	5	201	0	43465	67126	11188

**Table 7, cont.: 1995 TRI Releases for Foundries, by Number of Facilities Reporting
(Releases reported in pounds/year)**

CHEMICAL NAME	# REPORTING CHEMICAL	FUGITIVE AIR	POINT AIR	WATER DISCHARGES	UNDERGROUND INJECTION	LAND DISPOSAL	TOTAL RELEASES	AVG. RELEASES PER FACILITY
CUMENE HYDROPEROXIDE	6	2000	1300	0	0	3400	6700	1117
HYDROGEN FLUORIDE	6	1250	1130	0	0	0	2380	397
BENZENE	5	3150	239000	7	0	36	242193	48439
CHLORINE	5	8	5	615	0	0	628	126
COBALT COMPOUNDS	4	15	505	0	0	0	520	130
N-BUTYL ALCOHOL	4	33272	250	0	0	0	33522	8381
4,4'-ISOPROPYLIDENEDIPHENOL	4	750	0	0	0	0	750	188
ANTIMONY	4	260	260	0	0	0	520	130
DICHLOROMETHANE	3	110912	0	0	0	0	110912	36971
METHYL ETHYL KETONE	3	39851	7820	0	0	0	47671	15890
TRICHLOROETHYLENE	3	30426	46996	0	0	0	77422	25807
STYRENE	3	33421	75457	0	0	0	108878	36293
TETRACHLOROETHYLENE	3	34450	16000	0	0	0	50450	16817
CADMIUM	3	5	6	0	0	0	11	4
NITRATE COMPOUNDS	2	1700	0	23000	0	0	24700	12350
CUMENE	2	340	150	0	0	0	490	245
ETHYLBENZENE	2	4610	18439	0	0	0	23049	11525
METHYL ISOBUTYL KETONE	2	41284	6367	0	0	0	47651	23826
ARSENIC	2	250	250	0	0	0	500	250
PHOSPHORUS (YELLOW OR WHITE)	2	10	255	750	0	0	1015	508
ANTIMONY COMPOUNDS	1	5	5	0	0	0	10	10
BERYLLIUM COMPOUNDS	1	0	0	0	0	0	0	0
URETHANE	1	0	0	0	0	0	0	0
HEXACHLOROETHANE	1	5	250	0	0	0	255	255
DIETHANOLAMINE	1	0	0	0	0	0	0	0
PROPYLENE	1	0	0	0	0	0	0	0
CRESOL (MIXED ISOMERS)	1	0	44,000	20	0	0	44,020	44,020
POLYCHLORINATED BIPHENYLS	1	0	0	0	0	0	0	0
1,1-DICHLORO-1-FLUOROETHANE	1	49,416	0	0	0	0	49,416	49,416
SELENIUM	1	0	5	0	0	0	5	5
	654	5,621,089	4,604,774	56,716	0	25,719,306	36,001,885	55,048

**Table 8: 1995 TRI Transfers for Foundries, by Number and Facilities Reporting
(Transfers reported in pounds/year)**

CHEMICAL NAME	# REPORTING CHEMICAL	POTW TRANSFERS	DISPOSAL TRANSFERS	RECYCLING TRANSFERS	TREATMENT TRANSFERS	ENERGY RECOVERY TRANSFERS	TOTAL TRANSFERS	AVG TRANSFER PER FACILITY
COPPER	249	3386	926053	12948705	49688	1	13927833	55935
NICKEL	182	5811	752487	2925158	23193	1	3706650	20366
CHROMIUM	182	3568	947383	2042419	14667	5	3008047	16528
MANGANESE	179	2598	6528832	2834670	59838	0	9425938	52659
PHENOL	89	2397	216754	5272	10282	2671	239976	2696
LEAD	76	1566	78229	828352	22767	1	930915	12249
DIISOCYANATES	65	5	110292	55	40449	2510	153561	2362
MANGANESE COMPOUNDS	50	4553	5800216	6143043	152468	0	12100280	242006
CHROMIUM COMPOUNDS	45	17857	4274721	5249563	1475	0	9543616	212080
COPPER COMPOUNDS	36	1375	101566	1288917	31743	0	1423601	39544
ZINC (FUME OR DUST)	35	861	592866	1420309	85916	0	2099952	59999
NICKEL COMPOUNDS	32	2093	101546	1463377	8969	0	1575985	49250
METHANOL	32	2	19260	0	608	2616	22486	703
ZINC COMPOUNDS	31	7308	3479603	4339541	581458	0	8407910	271223
ALUMINUM (FUME OR DUST)	31	7419	1347594	1205369	1500	0	2561882	82641
TRIETHYLAMINE	30	5	250	423423	228606	0	652284	21743
PHOSPHORIC ACID	26	255	228515	49474	8576	0	286820	11032
XYLENE (MIXED ISOMERS)	24	0	3391	12170	250	163869	179680	7487
COBALT	24	1574	21956	618986	7719	0	650235	27093
NAPHTHALENE	22	4	21270	6920	1490	8621	38305	1741
MOLYBDENUM TRIOXIDE	22	0	13042	4965	1086	0	19093	868
1,2,4-TRIMETHYLBENZENE	18	1	21671	6463	260	7922	36317	2018
LEAD COMPOUNDS	16	86	351495	120552	29284	0	501417	31339
FORMALDEHYDE	16	3845	44078	430	3530	0	51883	3243
TOLUENE	13	2	1300	0	0	7906	9208	708
BARIUM	13	294	121356	70525	6830	0	199255	15327
ALUMINUM OXIDE (FIBROUS FORMS)	11	0	651926	17405	0	0	669331	60848
CERTAIN GLYCOL ETHERS	10	0	6550	13000	255	0	19805	1981
SULFURIC ACID	10	600	15162	0	12850	0	28612	2861
NITRIC ACID	10	250	0	22772	35331	0	58353	5835
ETHYLENE GLYCOL	9	38810	53800	17368	0	0	109978	12220
HYDROCHLORIC ACID								
(1995 AND AFTER "ACID AEROSOLS" ONLY)	9	5	0	0	76000	0	76005	8445
N-METHYL-2-PYRROLIDONE	8	2435	26470	13000	4902	1933	48740	6093
AMMONIA	8	13195	0	40250	0	0	53445	6681
1,1,1-TRICHLOROETHANE	7	0	0	600	250	250	1100	157

**Table 8, cont.: 1995 TRI Transfers for Foundries, by Number and Facilities Reporting
(Transfers reported in pounds/year)**

CHEMICAL NAME	# REPORTING CHEMICAL	POTW TRANSFERS	DISPOSAL TRANSFERS	RECYCLING TRANSFERS	TREATMENT TRANSFERS	ENERGY RECOVERY TRANSFERS	TOTAL TRANSFERS	AVG TRANSFER PER FACILITY
BARIUM COMPOUNDS	6	0	170228	245735	250	0	416213	69369
CUMENE HYDROPEROXIDE	6	0	4900	0	250	0	5150	858
HYDROGEN FLUORIDE	6	250	0	47746	79000	0	126996	21166
BENZENE	5	2	250	0	0	0	252	50
CHLORINE	5	0	0	0	0	0	0	0
COBALT COMPOUNDS	4	0	5869	394655	0	0	400524	100131
N-BUTYL ALCOHOL	4	0	0	0	0	0	0	0
4,4'-ISOPROPYLIDENEDIPHENOL	4	0	78170	0	0	0	78170	19543
ANTIMONY	4	255	0	758	250	0	1263	316
DICHLOROMETHANE	3	0	28	0	0	0	28	9
METHYL ETHYL KETONE	3	0	0	6458	250	10822	17530	5843
TRICHLOROETHYLENE	3	0	0	1350	0	2000	3350	1117
STYRENE	3	0	0	0	0	355	355	118
TETRACHLOROETHYLENE	3	0	0	250	0	0	250	83
CADMIUM	3	0	0	0	10	0	10	3
NITRATE COMPOUNDS	2	3700	0	0	0	0	3700	1850
CUMENE	2	0	400	0	250	0	650	325
ETHYLBENZENE	2	0	0	0	0	750	750	375
METHYL ISOBUTYL KETONE	2	0	0	0	53	0	53	27
ARSENIC	2	0	0	250	0	0	250	125
PHOSPHORUS (YELLOW OR WHITE)	2	5	19532	15043	0	0	34580	17290
ANTIMONY COMPOUNDS	1	0	0	0	0	0	0	0
BERYLLIUM COMPOUNDS	1	0	400	0	0	0	400	400
URETHANE	1	0	3000	0	0	0	3000	3000
HEXACHLOROETHANE	1	0	0	0	0	0	0	0
DIETHANOLAMINE	1	1300	0	0	2400	0	3700	3700
PROPYLENE	1	0	0	0	0	0	0	0
CRESOL (MIXED ISOMERS)	1	6	6	6
POLYCHLORINATED BIPHENYLS	1	0	0	0
1,1-DICHLORO-1-FLUOROETHANE	1	0	0	0
SELENIUM	1	0	5	.	.	.	5	5
	554	127,678	27,142,416	44,845,298	1,584,953	212,233	73,915,683	113,021

IV.A.2. Toxic Release Inventory for Die Casting Facilities

According to the 1995 TRI data, the reporting die casting facilities released and transferred a total of approximately 13 million pounds of TRI chemicals during calendar year 1995. As with foundries, the releases and transfers for die casters are dominated by large volumes of metallic wastes. Evidence of the diversity of processes at die casting facilities reporting to TRI is found in the fact that all but three of the TRI reported chemicals (copper, nickel, and aluminum) are reported by fewer than ten percent of the facilities. The variability in facilities' pollutant profiles may be attributed primarily to the different types of metals cast.

Releases

Releases make up only four percent of die casters' total TRI-reportable chemicals (518,000 pounds). Almost all of these releases (99 percent) are released to the air through point source and fugitive emissions (see Table 9). Metallic wastes (primarily aluminum, zinc, and copper) account for over 67 percent of the releases. The remainder of the industry's releases are primarily solvents and other volatile organic compounds including, trichloroethylene, tetrachloroethylene, glycol ethers, hexachloroethane, and toluene, which account for 32 percent of the releases. In addition to air releases of chemicals reported to TRI, die casting facilities can be a source of particulates, carbon monoxide, nitrogen oxides and sulfur compounds due to the combustion of fossil fuels for metal melting, from the molten metal itself, and from die cleaning and lubricating operations.

Transfers

Off-site transfers of TRI chemicals account for 96 percent of die casters' total TRI-reportable chemicals (13 million pounds). Almost all off-site transfers (97 percent) reported by die casting facilities are sent off-site for recycling. Copper, aluminum, zinc, and nickel make up 98 percent of all transfers and are reported by the largest number of facilities (see Table 10). Chemicals sent off-site for disposal (primarily aluminum and copper) account for less than three percent of transfers. After metals, the next class of chemicals transferred are solvents. These chemicals account for only about one percent of total transfers.

**Table 9: 1995 TRI Releases for Die Casting Facilities, by Number of Facilities Reporting
(Releases reported in pounds/year)**

CHEMICAL NAME	# REPORTING CHEMICAL	FUGITIVE AIR	POINT AIR	WATER DISCHARGES	UNDERGROUND INJECTION	LAND DISPOSAL	TOTAL RELEASES	AVG. RELEASES PER FACILITY
COPPER	79	7,319	17,283	1,006	0	250	25,858	327
NICKEL	24	835	3,028	0	0	0	3,863	161
ALUMINUM (FUME OR DUST)	21	17,663	257,448	22	0	0	275,133	13,102
ZINC (FUME OR DUST)	10	6,747	19,842	0	0	0	26,589	2,659
LEAD	9	34	59	0	0	0	93	10
MANGANESE	9	552	824	0	0	0	1,376	153
ZINC COMPOUNDS	7	992	6,610	321	0	2,959	10,882	1,555
CHROMIUM	6	39	1,069	5	0	0	1,113	186
COPPER COMPOUNDS	3	84	1,853	0	0	0	1,937	646
MANGANESE COMPOUNDS	3	0	0	250	0	0	250	83
TRICHLOROETHYLENE	3	12,689	101,545	0	0	0	114,234	38,078
NITRIC ACID	3	250	1,000	0	0	0	1,250	417
CHLORINE	3	255	1,705	0	0	0	1,960	653
CERTAIN GLYCOL ETHERS	2	4,800	5,600	0	0	0	10,400	5,200
ETHYLENE GLYCOL	2	0	0	0	0	0	0	0
HYDROCHLORIC ACID (1995 AND AFTER "ACID AEROSOLS" ONLY)	2	500	0	0	0	0	500	250
SULFURIC ACID	2	250	750	0	0	0	1,000	500
LEAD COMPOUNDS	1	0	111	0	0	0	111	111
NICKEL COMPOUNDS	1	12	240	0	0	0	252	252
HEXACHLOROETHANE	1	1,146	10,316	0	0	0	11,462	11,462
STYRENE	1	1,450	0	0	0	0	1,450	1,450
PROPYLENE	1	0	0	0	0	0	0	0
TRIETHYLAMINE	1	250	5	0	0	0	255	255
TETRACHLOROETHYLENE	1	5,800	23,200	.	0	0	29,000	29,000
BERYLLIUM	1	0	0	0	0	5	5	5
	100	61,667	452,488	1,604	0	3,214	518,973	5,189

**Table 10: 1995 TRI Transfers for Die Casting Facilities, by Number and Facilities Reporting
(Transfers reported in pounds/year)**

CHEMICAL NAME	# REPORTING CHEMICAL	POTW TRANSFERS	DISPOSAL TRANSFERS	RECYCLING TRANSFERS	TREATMENT TRANSFERS	ENERGY RECOVERY TRANSFERS	TOTAL TRANSFERS	AVG TRANSFER PER FACILITY
COPPER	79	363	34,284	4,683,629	851	.	4,719,127	59,736
NICKEL	24	45	2,623	166,911	35	.	169,614	7,067
ALUMINUM (FUME OR DUST)	21	265	233,319	4,852,664	5	.	5,086,253	242,203
ZINC (FUME OR DUST)	10	11	20,810	258,685	5	.	279,511	27,951
LEAD	9	20	515	10,443	10	.	10,988	1,221
MANGANESE	9	10	776	5,997	.	.	6,783	754
ZINC COMPOUNDS	7	303	5,259	488,477	6,955	.	500,994	71,571
CHROMIUM	6	15	760	750	15	.	1,540	257
COPPER COMPOUNDS	3	1	502	64,928	.	.	65,431	21,810
MANGANESE COMPOUNDS	3	5	16,400	.	4,752	.	21,157	7,052
TRICHLOROETHYLENE	3	0	1,836	66,330	800	.	68,966	22,989
NITRIC ACID	3	98	.	.	24,324	.	24,422	8,141
CHLORINE	3	0	0	0
CERTAIN GLYCOL ETHERS	2	0	.	50,000	.	.	50,000	25,000
ETHYLENE GLYCOL	2	4	70	.	.	.	74	37
HYDROCHLORIC ACID (1995 AND AFTER "ACID AEROSOLS" ONLY)	2	0	0	0
SULFURIC ACID	2	0	0	0
LEAD COMPOUNDS	1	0	360	1,500,000	.	.	1,500,360	1,500,360
NICKEL COMPOUNDS	1	0	54	7,767	.	.	7,821	7,821
HEXACHLOROETHANE	1	0	0	0
STYRENE	1	0	0	0
PROPYLENE	1	0	0	0
TRIETHYLAMINE	1	0	0	0
TETRACHLOROETHYLENE	1	.	.	2,009	.	.	2,009	2,009
BERYLLIUM	1	0	.	750	.	.	750	750
	100	1,140	317,568	12,159,340	37,752	0	12,515,800	125,158

The TRI database contains a detailed compilation of self-reported, facility-specific chemical releases. The top reporting facilities for the metal casting industry are listed below in Tables 11 and 12. Facilities that have reported only the primary SIC codes covered under this notebook appear on Table 11. Table 12 contains additional facilities that have reported the SIC codes covered within this notebook, or SIC codes covered within this notebook report and one or more SIC codes that are not within the scope of this notebook. Therefore, the second list may include facilities that conduct multiple operations -- some that are under the scope of this notebook, and some that are not. Currently, the facility-level data do not allow pollutant releases to be broken apart by industrial process.

Rank	Foundries (SIC 332, 3365, 3366, 3369)		Die Casters (SIC 3363, 3364)	
	Facility	Total TRI Releases in Pounds	Facility	Total TRI Releases in Pounds
1	GM Powertrain Defiance - Defiance, OH	14,730,020	Water Gremlin Co. - White Bear Lake, MN	97,111
2	GMC Powertrain - Saginaw, MI	2,709,764	BTR Precision Die Casting - Russelville, KY	93,903
3	American Steel Foundries - Granite City, IL	1,245,343	QX Inc. - Hamel, MN	67,772
4	Griffin Wheel Co. - Keokuk, IA	1,065,104	AAP St. Marys Corp. - Saint Marys, OH	55,582
5	Griffin Wheel Co. - Groveport, OH	1,042,040	Impact Industries Inc. - Sandwich, IL	45,175
6	Griffin Wheel Co. - Bessemer, AL	742,135	Tool-Die Eng. Co. - Solon, OH	29,005
7	U.S. Pipe & Foundry Co. - Birmingham, AL	738,200	Chrysler Corp. - Kokomo, IN	20,652
8	American Steel Foundries - East Chicago, IN	625,191	Metalloy Corp. - Fremont, IN	13,350
9	Griffin Wheel Co. - Kansas City, KS	607,266	Tool Products. Inc. - New Hope, MN	12,194
10	CMI - Cast Parts, Inc. - Cadillac, MI	604,100	Travis Pattern & Foundry, Inc. - Spokane, WA	11,614

Source: *US Toxics Release Inventory Database, 1995.*

¹ Being included on this list does not mean that the release is associated with non-compliance with environmental laws.

Rank	Foundries (SIC 332, 3365, 3366, 3369)			Die Casters (SIC 3363, 3364)		
	Facility	SIC Codes Reported in TRI	Total TRI Releases in Pounds	Facility	SIC Codes Reported in TRI	Total TRI Releases in Pounds
1	GM Powertrain Defiance - Defiance, OH	3321	14,730,020	Water Gremlin Co. - White Bear Lake, MN	3364, 3949	97,111
2	GMC Powertrain - Saginaw, MI	3321, 3365	2,709,764	BTR Precision Die Casting - Russelville, KY	3363	93,903
3	Heatcraft Inc. - Grenada, MS	3585, 3351, 3366	1,369,306	Honeywell Inc. Home & Building - Golden Valley, MN	3822, 3363, 3900	87,937
4	American Steel Foundries - Granite City, IL	3325	1,245,343	QX Inc. - Hamel, MN	3363	67,772
5	Griffin Wheel Co. - Keokuk, IA	3325	1,065,104	AAP St. Marys Corp. - Saint Marys, OH	3363	55,582
6	Griffin Wheel Co. - Groveport, OH	3325	1,042,040	Impact Industries Inc. - Sandwich, IL	3363	45,175
7	Geneva Steel - Vineyard, UT	3312, 3317, 3325	901,778	Tool-Die Eng. Co. - Solon, OH	3363	29,005
8	Griffin Wheel Co. - Bessemer, AL	3325	742,135	TAC Manufacturing - Jackson, MI	3086, 3363, 3714	25,684
9	U.S. Pipe & Foundry Co. - Birmingham, AL	3321	738,200	Superior Ind. Intl., Inc. - Johnson City, TN	3714, 3363, 3398	25,250
10	American Steel Foundries - East Chicago, IN	3325	625,191	General Electric Co. - Hendersonville, NC	3646, 3363	20,780

Source: *US Toxics Release Inventory Database, 1995.*

² Being included on this list does not mean that the release is associated with non-compliance with environmental laws.

IV.B. Summary of Selected Chemicals Released

The following is a synopsis of current scientific toxicity and fate information for the top chemicals (by weight) that facilities within this sector self-reported as released to the environment based upon 1995 TRI data. Because this section is based upon self-reported release data, it does not attempt to provide information on management practices employed by the sector to reduce the release of these chemicals. Information regarding pollutant release reduction over time may be available from EPA's TRI and 33/50 programs, or directly from the industrial trade associations that are listed in Section IX of this document. Since these descriptions are cursory, please consult these sources for a more detailed description of both the chemicals described in this section, and the chemicals that appear on the full list of TRI chemicals appearing in Section IV.A.

The brief descriptions provided below were taken from the Hazardous Substances Data Bank (HSDB) and the Integrated Risk Information System (IRIS). The discussions of toxicity describe the range of possible adverse health effects that have been found to be associated with exposure to these chemicals. These adverse effects may or may not occur at the levels released to the environment. Individuals interested in a more detailed picture of the chemical concentrations associated with these adverse effects should consult a toxicologist or the toxicity literature for the chemical to obtain more information. The effects listed below must be taken in context of these exposure assumptions that are explained more fully within the full chemical profiles in HSDB. For more information on TOXNET³, contact the TOXNET help line at 1-800-231-3766.

Manganese and Manganese Compounds (CAS: 7439-96-5; 20-12-2)

Sources. Manganese is found in iron charge materials and is used as an addition agent for alloy steel to obtain desired properties in the final product. In carbon steel, manganese is used to combine with sulfur to improve the

³ TOXNET is a computer system run by the National Library of Medicine that includes a number of toxicological databases managed by EPA, National Cancer Institute, and the National Institute for Occupational Safety and Health. For more information on TOXNET, contact the TOXNET help line at 800-231-3766. Databases included in TOXNET are: CCRIS (Chemical Carcinogenesis Research Information System), DART (Developmental and Reproductive Toxicity Database), DBIR (Directory of Biotechnology Information Resources), EMICBACK (Environmental Mutagen Information Center Backfile), GENE-TOX (Genetic Toxicology), HSDB (Hazardous Substances Data Bank), IRIS (Integrated Risk Information System), RTECS (Registry of Toxic Effects of Chemical Substances), and TRI (Toxic Chemical Release Inventory). HSDB contains chemical-specific information on manufacturing and use, chemical and physical properties, safety and handling, toxicity and biomedical effects, pharmacology, environmental fate and exposure potential, exposure standards and regulations, monitoring and analysis methods, and additional references.

ductility of the steel. An alloy steel with manganese is used for applications involving small sections which are subject to severe service conditions, or in larger sections where the weight saving derived from the higher strength of the alloy steels is needed (U.S. EPA, 1995).

Toxicity. There is currently no evidence that human exposure to manganese at levels commonly observed in ambient atmosphere results in adverse health effects.

Chronic manganese poisoning, however, bears some similarity to chronic lead poisoning. Occurring via inhalation of manganese dust or fumes, it primarily involves the central nervous system. Early symptoms include languor, speech disturbances, sleepiness, and cramping and weakness in legs. A stolid mask-like appearance of face, emotional disturbances such as absolute detachment broken by uncontrollable laughter, euphoria, and a spastic gait with a tendency to fall while walking are seen in more advanced cases. Chronic manganese poisoning is reversible if treated early and exposure stopped. Populations at greatest risk of manganese toxicity are the very young and those with iron deficiencies.

Ecologically, although manganese is an essential nutrient for both plants and animals, in excessive concentrations manganese inhibits plant growth.

Carcinogenicity. There is currently no evidence to suggest that manganese is carcinogenic.

Environmental Fate. Manganese is an essential nutrient for plants and animals. As such, manganese accumulates in the top layers of soil or surface water sediments and cycles between the soil and living organisms. It occurs mainly as a solid under environmental conditions, though may also be transported in the atmosphere as a vapor or dust.

Zinc and Zinc Compounds (CAS: 7440-66-6; 20-19-9)

Sources. To protect metal from oxidizing, it is often coated with a material that will protect it from moisture and air. In the galvanizing process, steel is coated with zinc. Galvanized iron and steel is often found in furnace charge materials (USITC, 1984).

Toxicity. Zinc is a trace element; toxicity from ingestion is low. Severe exposure to zinc might give rise to gastritis with vomiting due to swallowing of zinc dusts. Short-term exposure to very high levels of zinc is linked to lethargy, dizziness, nausea, fever, diarrhea, and reversible pancreatic and neurological damage. Long-term zinc poisoning causes irritability, muscular stiffness and pain, loss of appetite, and nausea.

Zinc chloride fumes cause injury to mucous membranes and to the skin. Ingestion of soluble zinc salts may cause nausea, vomiting, and purging.

Carcinogenicity. There is currently no evidence to suggest that zinc is carcinogenic.

Environmental Fate. Significant zinc contamination of soil is only seen in the vicinity of industrial point sources. Zinc is a stable soft metal, though it burns in air. Zinc bioconcentrates in aquatic organisms.

Methanol (CAS: 67-56-1)

Sources. Methanol is used as a cleaning solvent and can be emitted during the production of cores using the hot box and no-bake systems.

Toxicity. Methanol is readily absorbed from the gastrointestinal tract and the respiratory tract, and is toxic to humans in moderate to high doses. In the body, methanol is converted into formaldehyde and formic acid. Methanol is excreted as formic acid. Observed toxic effects at high dose levels generally include central nervous system damage and blindness. Long-term exposure to high levels of methanol via inhalation cause liver and blood damage in animals.

Ecologically, methanol is expected to have low toxicity to aquatic organisms. Concentrations lethal to half the organisms of a test population are expected to exceed one mg methanol per liter water. Methanol is not likely to persist in water or to bioaccumulate in aquatic organisms.

Carcinogenicity. There is currently no evidence to suggest that methanol is carcinogenic.

Environmental Fate. Methanol is highly volatile and flammable. Liquid methanol is likely to evaporate when left exposed. Methanol reacts in air to produce formaldehyde which contributes to the formation of air pollutants. In the atmosphere it can react with other atmospheric chemicals or be washed out by rain. Methanol is readily degraded by microorganisms in soils and surface waters.

Trichloroethylene (CAS:79-01-6)

Sources. Trichloroethylene is used extensively as a cleaning solvent.

Toxicity. Trichloroethylene was once used as an anesthetic, though its use caused several fatalities due to liver failure. Short term inhalation exposure to high levels of trichloroethylene may cause rapid coma followed by eventual death from liver, kidney, or heart failure. Short-term exposure to lower concentrations of trichloroethylene causes eye, skin, and respiratory tract irritation. Ingestion causes a burning sensation in the mouth, nausea, vomiting and abdominal pain. Delayed effects from short-term trichloroethylene poisoning include liver and kidney lesions, reversible nerve degeneration, and psychic disturbances. Long-term exposure can produce headache, dizziness, weight loss, nerve damage, heart damage, nausea, fatigue, insomnia, visual impairment, mood perturbation, sexual problems, dermatitis, and rarely jaundice. Degradation products of trichloroethylene (particularly phosgene) may cause rapid death due to respiratory collapse.

Carcinogenicity. Trichloroethylene is considered by EPA to be a probable human carcinogen via both oral and inhalation exposure, based on limited human evidence and sufficient animal evidence.

Environmental Fate. Trichloroethylene breaks down slowly in water in the presence of sunlight and bioconcentrates moderately in aquatic organisms. The main removal of trichloroethylene from water is via rapid evaporation. Trichloroethylene does not photodegrade in the atmosphere, though it breaks down quickly under smog conditions, forming other pollutants such as phosgene, dichloroacetyl chloride, and formyl chloride. In addition, trichloroethylene vapors may be decomposed to toxic levels of phosgene in the presence of an intense heat source such as an open arc welder. When spilled on land, trichloroethylene rapidly volatilizes from surface soils. Some of the remaining chemical may leach through the soil to groundwater.

Xylenes (Mixed Isomers) (CAS: 1330-20-7)

Sources. Xylenes are used extensively as cleaning solvents and paint solvents and may be formed as a decomposition product of binders.

Toxicity. Xylenes are rapidly absorbed into the body after inhalation, ingestion, or skin contact. Short-term exposure of humans to high levels of xylene can cause irritation of the skin, eyes, nose, and throat, difficulty in breathing, impaired lung function, impaired memory, and possible changes in the liver and kidneys. Both short- and long-term exposure to high concentrations can cause effects such as headaches, dizziness, confusion, and

lack of muscle coordination. Reactions of xylenes (see environmental fate) in the atmosphere contribute to the formation of ozone in the lower atmosphere. Ozone can affect the respiratory system, especially in sensitive individuals such as asthma or allergy sufferers.

Carcinogenicity. There is currently no evidence to suggest that xylenes are carcinogenic.

Environmental Fate. A portion of releases to land and water will quickly evaporate, although some degradation by microorganisms will occur. Xylenes are moderately mobile in soils and may leach into groundwater, where they may persist for several years. Xylenes are volatile organic chemicals. As such, xylene in the lower atmosphere will react with other atmospheric components, contributing to the formation of ground-level ozone and other air pollutants.

Chromium and Chromium Compounds (CAS: 7440-47-3; 20-06-4)

Sources. Chromium is used as a plating element for metal to prevent corrosion and is sometimes found on charge materials. Chromium is also a constituent of stainless steel.

Toxicity. Although the naturally-occurring form of chromium metal has very low toxicity, chromium from industrial emissions is highly toxic due to strong oxidation characteristics and cell membrane permeability. The majority of the effects detailed below are based on Chromium VI (an isomer that is more toxic than Cr III). Exposure to chromium metal and insoluble chromium salts affects the respiratory system. Inhalation exposure to chromium and chromium salts may cause severe irritation of the upper respiratory tract and scarring of lung tissue. Dermal exposure to chromium and chromium salts can also cause sensitive dermatitis and skin ulcers.

Ecologically, although chromium is present in small quantities in all soils and plants, it is toxic to plants at higher soil concentrations (i.e., 0.2 to 0.4 percent in soil).

Carcinogenicity. Different sources disagree on the carcinogenicity of chromium. Although an increased incidence in lung cancer among workers in the chromate-producing industry has been reported, data are inadequate to confirm that chromium is a human carcinogen. Other sources consider chromium VI to be a known human carcinogen based on inhalation exposure.

Environmental Fate. Chromium is a non-volatile metal with very low solubility in water. If applied to land, most chromium remains in the upper five centimeters of soil. Most chromium in surface waters is present in particulate form as sediment. Airborne chromium particles are relatively unreactive and are removed from the air through wet and dry deposition. The precipitated chromium from the air enters surface water or soil. Chromium bioaccumulates in plants and animals, with an observed bioaccumulation factor of 1,000,000 in snails.

IV.C. Other Data Sources

The toxic chemical release data obtained from TRI captures only about one quarter of the facilities in the metal casting industry. However, it allows for a comparison across years and industry sectors. Reported chemicals are limited to the approximately 600 TRI chemicals. A large portion of the emissions from metal casting facilities, therefore, are not captured by TRI. The EPA Office of Air Quality Planning and Standards has compiled air pollutant emission factors for determining the total air emissions of priority pollutants (e.g., total hydrocarbons, SO_x, NO_x, CO, particulates, etc.) from many metal casting sources.

The Aerometric Information Retrieval System (AIRS) contains a wide range of information related to stationary sources of air pollution, including the emissions of a number of air pollutants which may be of concern within a particular industry. With the exception of volatile organic compounds (VOCs), there is little overlap with the TRI chemicals reported above. Table 13 summarizes annual releases (from the industries for which a Sector Notebook Profile was prepared) of carbon monoxide (CO), nitrogen dioxide (NO₂), particulate matter of 10 microns or less (PM₁₀), sulfur dioxide (SO₂), and volatile organic compounds (VOCs).

Table 13: Air Pollutant Releases by Industry Sector (tons/year)						
Industry Sector	CO	NO₂	PM₁₀	PT	SO₂	VOC
Metal Mining	4,670	39,849	63,541	173,566	17,690	915
Nonmetal Mining	25,922	22,881	40,199	128,661	18,000	4,002
Lumber and Wood Production	122,061	38,042	20,456	64,650	9,401	55,983
Furniture and Fixtures	2,754	1,872	2,502	4,827	1,538	67,604
Pulp and Paper	566,883	358,675	35,030	111,210	493,313	127,809
Printing	8,755	3,542	405	1,198	1,684	103,018
Inorganic Chemicals	153,294	106,522	6,703	34,664	194,153	65,427
Organic Chemicals	112,410	187,400	14,596	16,053	176,115	180,350
Petroleum Refining	734,630	355,852	27,497	36,141	619,775	313,982
Rubber and Misc. Plastics	2,200	9,955	2,618	5,182	21,720	132,945
Stone, Clay and Concrete	105,059	340,639	192,962	662,233	308,534	34,337
Iron and Steel	1,386,461	153,607	83,938	87,939	232,347	83,882
Nonferrous Metals	214,243	31,136	10,403	24,654	253,538	11,058
Fabricated Metals	4,925	11,104	1,019	2,790	3,169	86,472
Electronics and Computers	356	1,501	224	385	741	4,866
Motor Vehicles, Bodies, Parts and Accessories	15,109	27,355	1,048	3,699	20,378	96,338
Dry Cleaning	102	184	3	27	155	7,441
Ground Transportation	128,625	550,551	2,569	5,489	8,417	104,824
Metal Casting	116,538	11,911	10,995	20,973	6,513	19,031
Pharmaceuticals	6,586	19,088	1,576	4,425	21,311	37,214
Plastic Resins and Manmade Fibers	16,388	41,771	2,218	7,546	67,546	74,138
Textiles	8,177	34,523	2,028	9,479	43,050	27,768
Power Generation	366,208	5,986,757	140,760	464,542	13,827,511	57,384
Shipbuilding and Repair	105	862	638	943	3,051	3,967

Source: U.S. EPA Office of Air and Radiation, AIRS Database, 1997.

IV.D. Comparison of Toxic Release Inventory Between Selected Industries

The following information is presented as a comparison of pollutant release and transfer data across industrial categories. It is provided to give a general sense as to the relative scale of TRI releases and transfers within each sector profiled under this project. Please note that the following figure and table do not contain releases and transfers for industrial categories that are not included in this project, and thus cannot be used to draw conclusions regarding the total release and transfer amounts that are reported to TRI. Similar information is available within the annual TRI Public Data Release Book.

Figure 10 is a graphical representation of a summary of the 1995 TRI data for the metal casting industry and the other sectors profiled in separate notebooks. The bar graph presents the total TRI releases and total transfers on the vertical axis. The graph is based on the data shown in Table 14 and is meant to facilitate comparisons between the relative amounts of releases, transfers, and releases per facility both within and between these sectors. The reader should note, however, that differences in the proportion of facilities captured by TRI exist between industry sectors. This can be a factor of poor SIC matching and relative differences in the number of facilities reporting to TRI from the various sectors. In the case of the metal casting industry, the 1995 TRI data presented here covers 654 facilities. These facilities listed SIC 332 (Iron and Steel Foundries) and 336 (Nonferrous Foundries) as primary SIC codes.

Figure 10: Summary of TRI Releases and Transfers by Industry

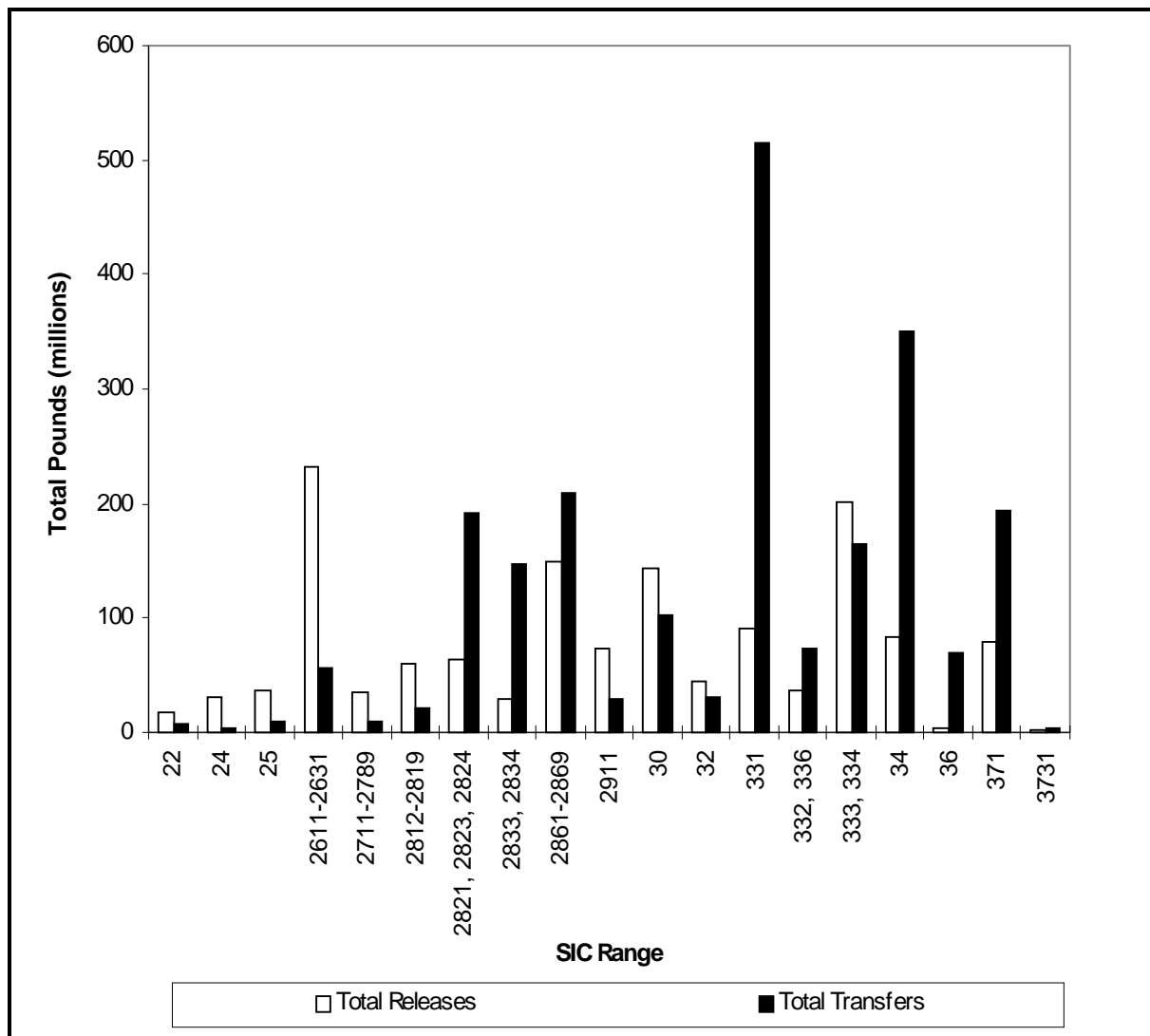

Source: US EPA 1995 Toxics Release Inventory Database.

SIC Range	Industry Sector	SIC Range	Industry Sector	SIC Range	Industry Sector
22	Textiles	2833, 2834	Pharmaceuticals	333, 334	Nonferrous Metals
24	Lumber and Wood Products	2861-2869	Organic Chem. Mfg.	34	Fabricated Metals
25	Furniture and Fixtures	2911	Petroleum Refining	36	Electronic Equip. and Comp.
2611-2631	Pulp and Paper	30	Rubber and Misc. Plastics	371	Motor Vehicles, Bodies, Parts, and Accessories
2711-2789	Printing	32	Stone, Clay, and Concrete	3731	Shipbuilding
2812-2819	Inorganic Chemical Manufacturing	331	Iron and Steel		
2821, 2823, 2824	Plastic Resins and Manmade Fibers	332, 336	Metal Casting		

Table 14: Toxics Release Inventory Data for Selected Industries

Industry Sector	SIC Range	# TRI Facilities	TRI Releases		TRI Transfers		Total Releases + Transfers (million lbs.)	Average Releases + Transfers per Facility (pounds)
			Total Releases (million lbs.)	Ave. Releases per Facility (pounds)	Total Transfers (million lbs.)	Ave. Trans. per Facility (pounds)		
Textiles	22	339	17.8	53,000	7.0	21,000	24.8	74,000
Lumber and Wood Products	24	397	30.0	76,000	4.1	10,000	34.1	86,000
Furniture and Fixtures	25	336	37.6	112,000	9.9	29,000	47.5	141,000
Pulp and Paper	2611-2631	305	232.6	763,000	56.5	185,000	289.1	948,000
Printing	2711-2789	262	33.9	129,000	10.4	40,000	44.3	169,000
Inorganic Chem. Mfg.	2812-2819	413	60.7	468,000	21.7	191,000	438.5	659,000
Plastic Resins and Manmade Fibers	2821,2823, 2824	410	64.1	156,000	192.4	469,000	256.5	625,000
Pharmaceuticals	2833, 2834	200	29.9	150,000	147.2	736,000	177.1	886,000
Organic Chemical Mfg.	2861-2869	402	148.3	598,000	208.6	631,000	946.8	1,229,000
Petroleum Refining	2911	180	73.8	410,000	29.2	162,000	103.0	572,000
Rubber and Misc. Plastics	30	1,947	143.1	73,000	102.6	53,000	245.7	126,000
Stone, Clay, and Concrete	32	623	43.9	70,000	31.8	51,000	75.7	121,000
Iron and Steel	331	423	90.7	214,000	513.9	1,215,000	604.6	1,429,000
Metal Casting	332, 336	654	36.0	55,000	73.9	113,000	109.9	168,000
Nonferrous Metals	333, 334	282	201.7	715,000	164	582,000	365.7	1,297,000
Fabricated Metals	34	2,676	83.5	31,000	350.5	131,000	434.0	162,000
Electronic Equip. and Comp.	36	407	4.3	11,000	68.8	169,000	73.1	180,000
Motor Vehicles, Bodies, Parts, and Accessories	371	754	79.3	105,000	194	257,000	273.3	362,000
Shipbuilding	3731	43	2.4	56,000	4.1	95,000	6.5	151,000

Source: US EPA Toxics Release Inventory Database, 1995.

V. POLLUTION PREVENTION OPPORTUNITIES

The best way to reduce pollution is to prevent it in the first place. Some companies have creatively implemented pollution prevention techniques that improve efficiency and increase profits while at the same time minimizing environmental impacts. This can be done in many ways such as reducing material inputs, re-engineering processes to reuse by-products, improving management practices, and employing substitution of toxic chemicals. Some smaller facilities are able to actually get below regulatory thresholds just by reducing pollutant releases through aggressive pollution prevention policies.

The Pollution Prevention Act of 1990 established a national policy of managing waste through source reduction, which means preventing the generation of waste. The Pollution Prevention Act also established as national policy a hierarchy of waste management options for situations in which source reduction cannot be implemented feasibly. In the waste management hierarchy, if source reduction is not feasible the next alternative is recycling of wastes, followed by energy recovery, and waste treatment as a last alternative.

In order to encourage these approaches, this section provides both general and company-specific descriptions of some pollution prevention advances that have been implemented within the metal casting industry. While the list is not exhaustive, it does provide core information that can be used as the starting point for facilities interested in beginning their own pollution prevention projects. This section provides summary information from activities that may be, or are being implemented by this sector. When possible, information is provided that gives the context in which the technique can be used effectively. Please note that the activities described in this section do not necessarily apply to all facilities that fall within this sector. Facility-specific conditions must be carefully considered when pollution prevention options are evaluated, and the full impacts of the change must examine how each option affects air, land and water pollutant releases.

Most of the pollution prevention activities in the metal casting industry have concentrated on reducing waste sand, waste electric arc furnace (EAF) dust and desulfurization slag, and increasing the overall energy efficiency of the processes. This section describes some of the pollution prevention opportunities for foundries within each of these areas.

V.A. Waste Sand and Chemical Binder Reduction and Reuse

Disposal of waste foundry sand in off-site landfills has become less appealing to foundry operators in recent years. Landfill disposal fees have increased considerably, especially in areas that suffer from shortages of landfill capacity. Landfill disposal can be a long-term CERCLA liability as well (see Section

VI.A. for a discussion of CERCLA). Currently, about 2 percent of foundry waste sands generated is considered hazardous waste under RCRA requiring expensive special treatment, handling and disposal in hazardous waste landfills. Therefore, there are strong financial incentives for applying pollution prevention techniques that reduce waste foundry sand generation. In fact, for years many foundries have been implementing programs to reduce the amounts of waste sand they generate. Also, the industry is conducting a significant amount of research in this area (AFS, 1996).

V.A.1. Casting Techniques Reducing Waste Foundry Sand Generation

The preferable approach to reducing disposal of waste sands is through source reduction rather than waste management and pollution control or treatment techniques. Foundry operators aiming to reduce waste sand may want to examine the feasibility and economic incentives of new casting methods for all or part of their production. A number of the casting techniques described in Section III.A such as investment casting, permanent mold casting, die casting, and lost foam casting generate less sand waste than other techniques.

Adopting different casting methods, however, may not always be feasible depending on the physical characteristics of the parts to be cast (e.g., type of metal, casting size and configuration, tolerances and surface finish required, etc.), the capabilities of the alternative methods, and the economic feasibility. When considering the economic feasibility of implementing these alternative methods, the savings in waste sand handling and disposal and raw material costs should be examined.

In addition to the more common methods listed above and described in Section III.A, there are a number of lesser known and/or new casting methods that also have the potential to reduce the volume of foundry waste sand generated. One promising method, vacuum molding, is described below. For additional information on new, alternative casting techniques, see the references in Section IX.

Vacuum Molding

Vacuum molding, or the V-Process, uses a strong vacuum applied to free-flowing, dry, unbonded sand around patterns in air tight flasks. The vacuum inside the mold results in a net pressure outside pushing in, holding the sand rigidly in the shape of the pattern even after the pattern is removed. The process uses a specially designed plastic film to seal the open ends of the sand mold and the mold cavity. After the pattern is removed, the mold halves are placed together and the metal is poured. The plastic film inside the mold cavity melts and diffuses into the sand as it contacts the molten metal. When the metal has cooled, the vacuum is removed, allowing the sand to fall away from the casting. Shakeout equipment is not needed and virtually no waste

sand is generated. The V-Process can be used on almost all metal types, for all sizes and shapes. Although the process has not gained widespread use, it can be economical, uses very little energy and can produce castings with high dimensional accuracy and consistency (La Rue, 1989).

V.A.2. Reclamation and Reuse of Waste Foundry Sand and Metal

Although less preferable than source reduction, the more immediate shift in industry practices is towards waste reclamation and reuse. A number of techniques are being used to reclaim waste sand and return it to the mold and core making processes. In addition, markets for off-site reuse of waste foundry sand have also been found. (Unless otherwise noted, this section is based on the 1992 EPA Office of Research and Development report, *Guides to Pollution Prevention, The Metal Casting and Heat Treating Industry.*)

Waste Segregation

A substantial amount of sand contamination comes from mixing the various foundry waste streams with waste sand. The overall amount of sand being discarded can be reduced by implementing the following waste segregation steps:

- Replumbing the dust collector ducting on the casting metal gate cutoff saws to collect metal chips for easier recycling
- Installing a new baghouse on the sand system to separate the sand system dust from the furnace dust
- Installing a new screening system or magnetic separator on the main molding sand system surge hopper to continuously clean metal from the sand system
- Separate nonferrous foundry shot blast dust (often a hazardous waste stream) from other nonhazardous foundry and sand waste streams.
- Installing a magnetic separation system on the shotblast system to allow the metal dust to be recycled
- Changing the core sand knockout procedure to keep this sand from being mixed in with system sand prior to disposal

Screen and Separate Metal from Sand

Most foundries screen used sand before reusing it. Some employ several different screen types and vibrating mechanisms to break down large masses of sand mixed with metal chips. Coarse screens are used to remove large chunks of metal and core butts. The larger metal pieces collected in the screen are usually remelted in the furnace or sold to a secondary smelter. Increasingly fine screens remove additional metal particles and help classify the sand by size before it is molded. Some foundries remelt these smaller metal particles; other foundries sell this portion to metal reclaimers. The metal recovered during the screening process is often mixed with coarser sand components or has sand adhering to it. Therefore, remelting these pieces in the furnace generates large amounts of slag, especially when the smaller particles are remelted.

Reclaim Sand by Dry Scrubbing/Attrition

Reclaiming sand by dry scrubbing is widely used, and a large variety of equipment is available with capacities adaptable to most binder systems and foundry operations. Dry scrubbing may be divided into pneumatic or mechanical systems.

In pneumatic scrubbing, grains of sand are agitated in streams of air normally confined in vertical steel tubes called cells. The grains of sand are propelled upward; they impact each other and/or are thrust against a steel target to remove some of the binder. In some systems, grains are impacted against a steel target. Banks of tubes may be used depending on the capacity and degree of cleanliness desired. Retention time can be regulated, and fines are removed through dust collectors. In mechanical scrubbing, a variety of available equipment offers foundries a number of options. An impeller may be used to accelerate the sand grains at a controlled velocity in a horizontal or vertical plane against a metal plate. The sand grains impact each other and metal targets, thereby removing some of the binder. The speed of rotation has some control over impact energy. The binder and fines are removed by exhaust systems, and screen analysis is controlled by air gates or air wash separators. Additional equipment options include:

- A variety of drum types with internal baffles, impactors, and disintegrators that reduce lumps to grains and remove binder
- Vibrating screens with a series of decks for reducing lumps to grains, with recirculating features and removal of dust and fines
- Shot-blast cleaning equipment that may be incorporated into other specially designed units to form a complete casting cleaning/sand reclamation unit

- Vibro-energy systems that use synchronous and diametric vibration, where frictional and compressive forces separate binder from sand grains.

Southern Aluminum is a high-production automotive foundry in Bay Minette, Alabama. The company recently installed a rotating drum attrition/scrubber sand reclaimer unit to remove lumps and tramp aluminum from its spent green sand and core butts so that it could be used by an asphalt company. Spent sand is fed into one end of the rotating drum where the lumps are reduced and binder is scrubbed off the grains. The sand then enters a screening and classifying section, binder and fines are removed by a dust collector, and clean tramp metal is removed. The company is removing far more aluminum from the sand than expected (about 6,000 pounds per day) resulting in substantial cost savings. The equipment paid for itself before it finished treating three-months worth of spent sand stockpiled at the facility (Philbin, 1996).

Reclaim Sand with Thermal Systems

Most foundries recycle core and mold sands; however, these materials eventually lose their basic characteristics, and the portions no longer suitable for use are disposed of in a landfill. In the reclamation of chemically bonded sands, the system employed must be able to break the bond between the resin and sand and remove the fines that are generated. The systems employed most commonly are scrubbing/attrition and thermal (rotary reclamation) systems for resin-bonded sands.

Reclamation of green sand for reuse in a green sand system is practiced on a limited basis in the United States. However, reclamation of core sand and chemically bonded molding sand is widespread. Wet reclamation systems employed in the 1950s for handling green sands are no longer used. Specific thermal reclamation case studies are summarized in AFS (1989) and Modern Casting August (1996). A typical system to reclaim chemically bonded sand for reuse in core room and molding operations consists of a lump reduction and metal removal system, a particle classifier, a sand cooler, a dust collection system, and a thermal scrubber (two-bed reactor). A number of thermal sand reclamation techniques are described below. Note that EPA may classify some types of thermal sand reclamation as incineration. As of June 1996, EPA was taking comments on the regulatory status of thermal recovery units. Contact Mary Cunningham at (703) 308-8453.

Thermal Calcining/Thermal Dry Scrubbing. These systems are useful for reclamation of organic and clay-bonded systems. Sand grain surfaces are not smooth; they have numerous crevices and indentations. The application of heat with sufficient oxygen calcines the binders or burns off organic binders. Separate mechanical attrition units may be required to remove calcined

inorganic binders. Heat offers a simple method of reducing the encrusted grains of molding sand to pure grains. Both horizontal and vertical rotary kiln and fluidized bed systems are available. Foundries should examine the regulatory requirements of using thermal systems to treat waste sand. The use of these systems may need to be permitted as waste incineration.

Carondelet Foundry Company in Pevely, Missouri installed a fluidized bed thermal sand reclamation unit and a mechanical reclaimer in 1994 to treat its phenolic urethane no-bake and phenolic urethane Isocure sand. The steel jobbing shop was sending on average 150 tons per day of waste sand off-site for landfill disposal at a cost of about \$29 per cubic yard. In addition, new sand was costing approximately \$22 per ton. The thermal system processes 125 tons per day and the mechanical system processes the remaining 25 tons. Only 5 percent of the foundry's sand is not reclaimed. The reclamations system is estimated to save the foundry over \$1 million per year and payed for itself in under a year. In addition, the foundry feels that the reclaimed sand is better than new sand and results in better castings (Philbin, 1996).

Rotary Drum. This system has been used since the 1950s for reclaiming shell and chemically bonded sands. The direct-fired rotary drum is a refractory-lined steel drum that is mounted on casters. The feed end is elevated to allow the sand to flow freely through the unit. The burners can be at either end of the unit with direct flame impingement on the cascading sand; flow can be either with the flow of solids or counter to it.

In indirect-fired units, the drum is mounted on casters in the horizontal position and is surrounded by refractory insulation. Burners line the side of the drum, with the flames in direct contact with the metal drum. The feed end is elevated to allow the sand to flow freely through the unit, and in some cases flights (paddles connected by chains) are welded to the inside to assist material flow.

Multiple-Hearth Vertical Shaft Furnace. This furnace consists of circular refractory hearths placed one above the other and enclosed in a refractory-lined steel shell. A vertical rotating shaft through the center of the furnace is equipped with air-cooled alloy arms containing rabble blades (plows) that stir the sand and move it in a spiral path across each hearth.

Sand is repeatedly moved outward from the center of a given hearth to the periphery, where it drops through holes to the next hearth. This action gives excellent contact between sand grains and the heated gases. Material is fed into the top of the furnace. It makes its way to the bottom in a zigzag fashion, while the hot gases rise counter-currently, burning the organic material and calcining clay, if one or both are present. Discharge of reclaimed sand can be

directly from the bottom hearth into a tube cooler, or other cooling methods may be used. The units are best suited to large tonnages (five tons or more).

New approaches and equipment designed for sand reclamation units are continuing to evolve, and foundries must evaluate each system carefully with regard to the suitability for a particular foundry operation.

In 1988, R.H. Sheppard Company, Inc. in Hanover, Pennsylvania installed a thermal sand reclamation system to recover its 2,200 tons per year of waste green sand. Between the sand purchase price and disposal costs, the foundry was spending over \$180,000 per year. Even considering the \$428,500 capital investment and regular operation and maintenance costs, over the 20 year useful life of the equipment, the company estimates it will save about \$2 million. This does not include the intangible savings of reduced liability of waste sand disposal (Pennsylvania DEP, 1996).

Use Sand as a Construction Material

Depending on its physical and chemical characteristics, non-hazardous waste foundry sand can be used as construction material assuming a market can be found and federal, state, and local regulations relating to handling, storage, and disposal allow it. Many foundries currently recycle foundry waste sand for construction purposes. Industry research, however, indicates that only a small portion of the potential market for waste sand is being utilized. Some potential construction uses for waste sand include: feed stock for portland cement production; fine aggregate for concrete; fine construction aggregate for fill; and bituminous concrete (asphalt) fine aggregate.

Since late 1993, Viking Pump, Inc., of Cedar Falls, Iowa has been shipping spent sand to a portland cement manufacturer for use as a raw material. This reuse reduces the costs for the cement company because the need for mining virgin sand is reduced. Landfill costs for the foundry have been reduced creating a win-win situation for both companies. When Viking began testing foundry sand for use in cement manufacturing, the sand was loaded with an endloader into grain trucks for hauling to the cement plant. Completing a loading took almost an hour. Once the cement company decided that the waste sand was compatible with its process, Viking invested in a sand silo for storage. The sand is now conveyed to the silo and gravity fed into trucks for transportation, significantly reducing handling time to six minutes. Viking expects to send at least half of the spent foundry sand to the portland cement manufacturer and is continuing to look for alternative uses to achieve its pollution prevention goals (U.S. EPA Enviro\$en\$e Website, 1996).

Not all foundry sand will be ideal for all construction uses. For example, although many foundry sands actually increase compression strengths of concrete when used as a fine aggregate, green molding sands have been shown to decrease compression strengths. In addition, foundries will probably not be able to find markets for their waste sand in its “as-generated” condition. Some processing is typically required in order to match the customers’ product specifications. Waste sand may first need to be dried, crushed, screened and separated from metals.

Waste sand streams from certain foundry processes could render a foundry’s entire waste sand stream worthless if mixed together. A material flow diagram detailing the flow of sand and its characteristics (particle size distribution, mineralogical composition, moisture content, and chemical and contaminant concentration) through the production processes will help foundry operators identify those spent sand generation points that must be separated out for either processing and sale to a customer or for disposal in a landfill.

V.B. Metal Melting Furnaces

The metal casting industry is highly energy intensive and therefore has opportunities to prevent pollution through increasing energy efficiency. The majority of the energy is consumed by the furnaces used to melt metal; however, energy used in heat curing of sand molds can also be significant depending on the process used (DOE, 1996). Increases in energy efficiency in metal casting operations may have the dual pollution prevention effect of reducing fossil fuel consumption (and the associated environmental impacts) and reducing the amounts of wastes generated from furnaces and curing ovens (e.g., hazardous desulfurization slag, dust, VOCs, etc.). Since energy costs can be a large portion of a metal caster’s overall operating costs, increases in energy efficiency can also result in significant cost savings.

Improve Furnace Efficiency

Currently, many foundry furnaces are less than 35 percent energy efficient. Facilities using reverberatory or crucible furnaces may have opportunities to improve their furnace efficiency and stack emissions by upgrading their combustion system (DOE, 1996). New oxygen burners and computerized gas flow metering systems have helped a number of facilities to comply with Clean Air Act regulations for NO_x and CO emissions while reducing energy costs. Some foundries are utilizing regenerative ceramic burner systems. The systems are comprised of two burners which function alternately as a burner and an exhaust port. When one burner fires, the other collects the exhaust gases, recouping the heat from the waste gases. In the next cycle, this burner then fires, recombusting the gases. The recombustion of the waste gases ensures complete combustion and has been shown to reduce NO_x formation.

One firm implementing this system reported a 33 percent reduction in energy use and a better melting rate, improving production capacity (Binczewski, 1993).

Install Induction Furnaces

Induction furnaces may offer advantages over electric arc or cupola furnaces for some applications. Induction furnaces are about 75 to 80 percent energy efficient and emit about 75 percent less dust and fumes because of the absence of combustion gases or excessive metal temperatures. When clean scrap material is used, the need for emission control equipment may be minimized. Of course, production operations and process economics must be considered carefully when planning new or retrofit melting equipment (U.S. EPA, 1992).

Minimize Metal Melting

Depending on the casting, between reject castings and gating systems, over half of the metal poured into molds may not become a useful part of the casting. This metal needs to be separated from the castings and remelted, usually at a significant cost. Any increases in yield (reductions in the amount of scrap) will result in energy cost savings from eliminating the need for melting the excess metal. In addition, costs of separating scrap from the castings and waste sand, and the time and expense in machining of gating systems may be reduced. Gating system design that increases yield and reduces the need for machining can reduce a foundry's costs. Optimally designed systems will not use any more metal than is necessary while ensuring that the metal flows into the mold cavity properly to minimize casting defects. A number of computer software products are available to optimize casting design. These products simulate mold filling and casting solidification for various designs and can reduce costs by improving quality and reducing scrap.

A number of casting methods use a central sprue gated to a number of individual casting patterns. Such assemblies termed "trees" or pattern clusters, can generate less excess metal than single pattern mold designs. This technique is most commonly used in the investment and lost foam casting methods. A variation of the investment casting method termed, hollow sprue casting, or counter gravity casting, employs a vacuum to fill the mold with molten metal. A mold or mold cluster assembly fabricated using the investment casting technique is placed in a closed mold chamber with only the open end protruding from the bottom. The mold and mold chamber are lowered to the surface of a ladle or crucible of molten metal until the mold opening is below the surface. A vacuum is then applied to the mold chamber and mold, forcing the molten metal to rise and fill the mold and gating system. The vacuum is maintained until the casting and gates have solidified and is released before the sprue has solidified. The sprue metal then drains back into the molten metal for reuse. If the gating system is designed properly, over 90

percent of the metal becomes part of the useful casting.

Use Alternative Fuels for Melting

Some melt furnaces can utilize natural gas or fuel-oil as a fuel source. Particulate emissions from fuel oils tend to be much greater than emissions from natural gas combustion. If fuel oil must be used, particulate emissions can be reduced by using a lower grade of fuel oil. Petroleum distillates (Numbers 1 and 2 fuel oil) will result in lower particulate emissions than heavier grade fuels (Nos. 4,5,6). Sulfur dioxide emissions can be reduced by choosing a fuel with a low sulfur content. Emissions of nitrogen oxides result from the oxidation of nitrogen bound in the fuel. Selection of a low nitrogen fuel oil will reduce NO_x emissions (NADCA, 1996).

Air emissions from the operation of furnaces can be further reduced by using natural gas as a fuel source. Natural gas is considered a clean fuel which, when combusted, emits relatively small amounts of SO_x and particulate matter. The primary emission resulting from the combustion of natural gas is nitrogen oxides. NO_x emissions can be reduced by applying alternative firing techniques, including the recirculation of flue-gas, staged combustion, and the installation of low NO_x burners (NADCA, 1996).

Proper maintenance of furnaces will also help to reduce air emissions. Inefficient fuel/air mixing may generate excess particulate emissions.

V.C. Furnace Dust Management

Dust generation, especially in the Electric Arc Furnace (EAF), and its disposal, has been recognized as a serious problem, but one with potential for pollution prevention through material recovery and source reduction. EAF dust can have high concentrations of lead and cadmium. Some EAF dust can be shipped off-site for zinc reclamation. Most of the EAF dust recovery options are only economically viable for dust with a zinc content of at least 15 - 20 percent (U.S. EPA, 1995).

In-process recycling of EAF dust may involve pelletizing and then reusing the pellets in the furnace, however, recycling of EAF dust on-site has not proven to be technically or economically competitive for all foundries. Improvements in technologies have made off-site recovery a cost effective alternative to thermal treatment or secure landfill disposal.

Maintain Optimal Operating Parameters

Dust emissions from furnaces can often be minimized through a number of good operating practices. Such practices include: avoiding excessive superheating of the metal; maintaining a sufficient flux or slag cover over the metal to keep the molten metal separated from the atmosphere; preheating the metal charged; avoiding the addition of metals at maximum furnace temperatures; and avoiding the heating of the metal too fast.

Recycle EAF Dust to the Original Process

EAFs generate 1 to 2 percent of their charge into dust or fumes. If the zinc and lead levels of the metal dust are low, return of the dust to the furnace for recovery of base metals (iron, chromium, or nickel) may be feasible. This method may be employed with dusts generated by the production of stainless or alloy steels. However, this method is usually impractical for handling dust associated with carbon steel production because galvanized metal scrap is often used and the recovered dust tends to be high in zinc (U.S. EPA, 1992).

Many methods have been proposed for flue-dust recycling, including direct zinc recovery. Zinc content can be increased to the required 15 to 20 percent by returning the dust to the furnace from which it is generated. If the dust is injected into the furnace after the charge of scrap metal is melted, temperatures are high enough for most of the heavy metals to fume off. This technique results in an increased zinc concentration in the dust collected by the scrubbers, electrostatic precipitation systems, or baghouses (U.S. EPA, 1992).

Recycle Dust Outside the Original Process

Silica-based baghouse dust from sand systems and cupola furnaces may be used as a raw material by cement companies. The dust is preblended with other components and transferred to a kiln operation. It is envisioned that baghouse dusts may constitute 5 to 10 percent of the raw material used by cement manufacturers in the future. The use of higher levels may be limited by adverse effects of the baghouse dust on the setting characteristics of the cement (U.S. EPA, 1992).

Waste EAF dust can be reused outside the original process by reclaiming the zinc, lead, and cadmium concentrated in emission control residuals. The feasibility of such reclamation depends on the cost of dust treatment and disposal, the concentration of metals within the residual, the cost of recovering the metals, and the market price for the metals. While this approach is useful in the nonferrous foundry industry (i.e., brass foundries), its application within gray iron foundries is extremely limited. Some foundries market furnace dust as input to brick manufacturing and other consumer product applications, but product liability limits this option. Recovery methods include: pyrometallurgical, rotary kiln, electrothermic shaft furnace, and zinc oxide enrichment (U.S. EPA, 1992).

Pyrometallurgical methods for metals recovery are based on the reduction and volatilization of zinc, lead, cadmium, and other components of EAF dust. Lead is removed preferentially through roasting in an oxidizing environment, while zinc, cadmium and other metals are removed through roasting under reducing conditions. The rotary (or Waelz) kiln method can simultaneously reduce ferrous iron oxide to solid iron and lead and zinc oxide to their metallic forms, using a reducing atmosphere such as carbon monoxide and hydrogen. However, rotary kilns must be fairly large and must process large volumes of dust to be economically and thermally efficient. The electrothermic shaft furnace can extract metallic zinc from a feed containing at least 40 percent of the metal. Typically, agglomerated EAF dust is mixed with other feed to attain this percentage. To recycle dust by direct reduction of oxides, iron oxide is reduced to iron and water using pure hydrogen at a temperature range of 1000 to 1100°C. The reduction of zinc oxide produces zinc vapors and steam at 1000 to 1100°C that are removed from the furnace and subjected to an oxidation step. The zinc reacts with water to produce zinc oxide, and hydrogen is removed and recycled. The zinc oxide produced is separated in a baghouse. The hydrogen containing the steam is further treated for steam condensation, and then the hydrogen is ready for recycling into the furnace (U.S. EPA, 1992).

Alter Raw Materials

The predominant source of lead, zinc, and cadmium in ferrous foundry

baghouse dust or scrubber sludge is galvanized scrap metal used as a charge material. To reduce the level of these contaminants, their source must be identified and charge material containing lower concentrations of the contaminants must be acquired. A charge modification program at a large foundry can successfully reduce the lead and cadmium levels in dust collector waste to below EP-toxicity values. Foundries need to work closely with steel scrap suppliers to develop reliable sources of high-grade scrap.

V.D. Slag and Dross Management

Minimize Hazardous Desulfurizing Slag

In the production of ductile iron, it is often necessary to add a desulfurizing agent in the melt to produce the desired casting microstructure. One desulfurization agent used commonly is solid calcium carbide (CaC_2). Calcium carbide is thought to decompose to calcium and graphite. The calcium carbide desulfurization slag is generally removed from the molten iron in the ladle and placed into a hopper. For adequate sulfur removal, CaC_2 must be added in slight excess. Since an excess of CaC_2 is employed to ensure removal of the sulfur, the resulting slag contains both CaS and CaC_2 and must be handled as a reactive waste. The slag might also be hazardous due to high concentrations of heavy metals (U.S. EPA, 1992).

Treatment of this material consists normally of converting the carbide to acetylene and calcium hydroxide by reacting with water. Problems with this method include handling a potentially explosive waste material; generating a waste stream that contains sulfides (due to calcium sulfide in the slag) and many other toxic compounds; and liberating arsine, phosphine, and other toxic materials in the off gas (U.S. EPA, 1992).

One way to reduce the need for calcium carbide is to reduce the amount of high sulfur scrap used as furnace charge materials. While this method is effective, the ability to obtain a steady supply of high-grade scrap varies considerably and may be uneconomical (U.S. EPA, 1992).

To eliminate entirely the use of calcium carbide, several major foundries have investigated the use of alternative desulfurization agents. One proprietary process employs calcium oxide, calcium fluoride, and two other materials. The process can be more economical than carbide desulfurization and results in a satisfactory iron quality (U.S. EPA, 1992).

Often, the amount of sulfur removal for a product is based not on the requirements of that product but on what is achievable in practice. When total sulfur removal is required, it is not uncommon that 20 to 30 percent excess carbide is employed resulting in the generation of larger amounts of slag. If

the iron were desulfurized only to the extent actually needed, much of this waste could be reduced or eliminated (U.S. EPA, 1992).

Recycle Hazardous Desulfurizing Slag

Because calcium carbide slag is often removed from the metal by skimming, it is not uncommon to find large amounts of iron mixed in with the slag. Depending on the means of removal, this metal will either be in the form of large blocks or small granules. To reduce metal losses, some foundries crush the slag and remove pieces of metal by hand or with a magnet for remelting. Other foundries have investigated recharging the entire mass to the remelting furnace. Inside the furnace, calcium hydroxide forms in the slag as the recycled calcium carbide either removes additional sulfur or is oxidized directly. While this method has been successful, more research is necessary. For example, it is not known to what extent the calcium sulfide stays with the slag or how much sulfur is carried in the flue gas and the scrubber system. Initial tests indicate that the sulfur does not concentrate in the metal, so that product quality is not affected (U.S. EPA, 1992).

Slag from stainless steel melting operations (where Ni, Mo, and Cr metals are used as alloy additions) is hazardous as a result of high chromium concentrations. Such slag can be recycled as a feed to cupola furnaces (gray iron production line). The cupola furnace slag scavenges trace metals from the induction furnace slag. The resulting cupola slag may be rendered a nonhazardous waste (U.S. EPA, 1992).

Minimize Air Emissions During Dross and Slag Removal

Emissions resulting from the removal of dross and slag can be reduced by decreasing the time in which the dross is exposed to the air. This is true for dross and slag removal processes throughout the facility (e.g., melting, laundering, die casting). Dross and slag pots should be covered as soon as possible to eliminate emissions to the atmosphere. Alternative dross and slag handling techniques can also be practical to reduce emissions. Dross and slag pots can be positioned under or near exhaust hoods in order to divert the emissions to a filter or other emission control device (NADCA, 1996).

V.E. Wastewater*Reduce Phenols in Die Casting Wastewater Streams*

The major pollutants in the wastewater streams from die casting operations are oils and phenols, with the phenols being the regulated pollutant in most wastewater discharge situations. Common sources of phenols in die casting are the various oils used in the process, such as phosphate ester-based hydraulic oil, die lube, way lube, die cast coolant, etc. Cast salts, degreasers, and heat transfer oils may also contain phenols as an impurity (NADCA, 1996).

An effective method for source control of phenols would be to check each individual raw material used in die casting for phenols, and use or substitute with materials which have little or no phenols. For example, petroleum oils which often contain phenols as contaminants may be substituted with synthetic oils or water-based materials that contain no phenols. Although the alternative materials can be more costly than petroleum-based oils, the annual incremental cost increase may not be significant depending on the volume of material used. In addition, anticipated reductions in environmental control costs may outweigh potential raw material cost increases (NADCA, 1996).

Another effective method of reducing or eliminating phenols in wastewater consists of segregating the various waste streams at the point of generation by collecting the materials in catch pans and handling them separately. For example, die lube overspray can be collected in a metal pan installed below the die, screened to remove debris, filtered (if necessary) to remove fine particulate matter, treated (if necessary) for bacteria contamination, and recycled for reuse in the plant. Plunger lubricants and other drippings may also be collected in pans and recycled off-site as used oil (NADCA, 1996).

Reduce Wastewater and Sludge Generation

Water used to cool parts can be reduced by implementing cooling water recycling systems. Further wastewater reductions may be accomplished by optimizing deburring operations to minimize the total suspended solids in wastewater. This, in turn, will reduce the sludge generation from subsequent treatment. Sludge dewatering can also be optimized through the use of pH controls and filter aids (such as diatomaceous earth) to produce a drier filter cake prior to land disposal.

R.H. Sheppard Company, Inc. in Hanover, Pennsylvania used large quantities of fresh water for cooling metal parts as they were ground to fine tolerances. The company installed a 16,000 gallon closed loop cooling system with temperature and bacteria controls which improved the grinding process and saves 3.4 million gallons of water per year. From its reduced coolant disposal costs and savings in water costs, R.H. Sheppard Company expects a two- to three-year payback period on its \$540,000 investment (Pennsylvania DEP, 1996).

Reduce VOC Emissions from Cooling and Quench Water

The primary cause of air emissions from non-contact cooling water cooling towers and quench baths is the use of additives, such as biocides, which contain volatile organic compounds that are eventually emitted to the atmosphere. The best method for reducing air emissions from cooling towers and quench baths is to use fewer additives or to use additives containing no VOCs or Hazardous Air Pollutants (HAPs) (NADCA, 1996).

V.F. Die Casting Lubrication

The majority of emissions generated during the die casting process come from the application of die lubes. These emissions consist of VOC, particulate matter, and HAPs. VOC emissions from die lube application can be reduced by the use of water-based die lubricants or solid lubricants. Eliminating the volatile components of petroleum-based lubricants will also reduce VOC emissions when wet milling finishing techniques are used. However, it is important to note that lubricants which reduce VOC emissions may not necessarily reduce HAP emissions and, in some cases, HAP emissions may be greater from water-based die lubes. Apparently, some of the solvent replacement additives in water-based lubricants may result in increased HAP emissions. It is important to thoroughly evaluate the potential implications for air emissions before alternative lubricant products are used (NADCA, 1996).

In the same manner as VOC emissions, alternative lubricants can be used to reduce particulate emissions from the application of die lubes. However, lubricant-specific evaluations should be performed to determine the particulate emission reduction potential of individual lubricant changes (NADCA, 1996).

V.G. Miscellaneous Residual Wastes

The generation of solid wastes from shipping and receiving processes can be minimized through the use of reusable packaging materials. Metal casters can seek suppliers that use these materials, and work with customers to initiate their use of reusable shipping materials. Many of the common packaging materials in use today, including shrink wrap, strapping materials, cardboard, totes, and drums, can be recycled off-site using commercial recycling services.

(NADCA, 1996)

Dross from melting operations is commonly sold to secondary smelters for recovery of the valuable metals. Die casting shot-tip turnings can be re-sized on-site and re-used in the original process (NADCA, 1996).

Leaking hydraulic fluid from die cast machines can be segregated from other die cast fluids using drip pans and/or containment curbing. Leaking and spent hydraulic fluids may be collected and recycled as used oil. Used oil recycling options include re-refining and burning the material for energy recovery in space heaters, boilers, or industrial furnaces (NADCA, 1996).

Refractory, coils, and servicing tools must be periodically replaced in the melting and conveyance operations due to wear. Although the generation of these materials cannot be eliminated, their generation rates can be minimized by raising the pollution prevention awareness of maintenance personnel and optimizing maintenance and servicing schedules (NADCA, 1996).

The generation of floor absorbent solid waste at die cast machines can be minimized through the use of drip pans and containment berming. Hydraulic fluids, die release agents, way lubricants, and other leaking fluids can be collected in this manner. If floor absorbents are to be used, launderable absorbents should be considered. These absorbents are becoming available increasingly from industrial suppliers and laundry services, and can be reused over and over. The use of launderable absorbents results in reduced landfill disposal for both the absorbents and the recovered fluids (NADCA, 1996).

Page 94 intentionally left blank.

VI. SUMMARY OF FEDERAL STATUTES AND REGULATIONS

This section discusses the Federal regulations that may apply to this sector. The purpose of this section is to highlight and briefly describe the applicable Federal requirements, and to provide citations for more detailed information. The three following sections are included:

- Section VI.A. contains a general overview of major statutes
- Section VI.B. contains a list of regulations specific to this industry
- Section VI.C. contains a list of pending and proposed regulations

The descriptions within Section VI are intended solely for general information. Depending upon the nature or scope of the activities at a particular facility, these summaries may or may not necessarily describe all applicable environmental requirements. Moreover, they do not constitute formal interpretations or clarifications of the statutes and regulations. For further information, readers should consult the Code of Federal Regulations and other state or local regulatory agencies. EPA Hotline contacts are also provided for each major statute.

VI.A. General Description of Major Statutes

Resource Conservation and Recovery Act

The Resource Conservation And Recovery Act (RCRA) of 1976 which amended the Solid Waste Disposal Act, addresses solid (Subtitle D) and hazardous (Subtitle C) waste management activities. The Hazardous and Solid Waste Amendments (HSWA) of 1984 strengthened RCRA's waste management provisions and added Subtitle I, which governs underground storage tanks (USTs).

Regulations promulgated pursuant to Subtitle C of RCRA (40 CFR Parts 260-299) establish a "cradle-to-grave" system governing hazardous waste from the point of generation to disposal. RCRA hazardous wastes include the specific materials listed in the regulations (commercial chemical products, designated with the code "P" or "U"; hazardous wastes from specific industries/sources, designated with the code "K"; or hazardous wastes from non-specific sources, designated with the code "F") or materials which exhibit a hazardous waste characteristic (ignitability, corrosivity, reactivity, or toxicity and designated with the code "D").

Regulated entities that generate hazardous waste are subject to waste accumulation, manifesting, and record keeping standards. Facilities must obtain a permit either from EPA or from a State agency which EPA has authorized to implement the permitting program if they store hazardous wastes for more than 90 days before treatment or disposal. Facilities may

treat hazardous wastes stored in less-than-ninety-day tanks or containers without a permit. Subtitle C permits contain general facility standards such as contingency plans, emergency procedures, record keeping and reporting requirements, financial assurance mechanisms, and unit-specific standards. RCRA also contains provisions (40 CFR Part 264 Subpart S and §264.10) for conducting corrective actions which govern the cleanup of releases of hazardous waste or constituents from solid waste management units at RCRA-regulated facilities.

Although RCRA is a Federal statute, many States implement the RCRA program. Currently, EPA has delegated its authority to implement various provisions of RCRA to 47 of the 50 States and two U.S. territories. Delegation has not been given to Alaska, Hawaii, or Iowa.

Most RCRA requirements are not industry specific but apply to any company that generates, transports, treats, stores, or disposes of hazardous waste. Here are some important RCRA regulatory requirements:

- **Identification of Solid and Hazardous Wastes** (40 CFR Part 261) lays out the procedure every generator must follow to determine whether the material in question is considered a hazardous waste, solid waste, or is exempted from regulation.

- **Standards for Generators of Hazardous Waste** (40 CFR Part 262) establishes the responsibilities of hazardous waste generators including obtaining an EPA ID number, preparing a manifest, ensuring proper packaging and labeling, meeting standards for waste accumulation units, and recordkeeping and reporting requirements. Generators can accumulate hazardous waste for up to 90 days (or 180 days depending on the amount of waste generated) without obtaining a permit.

- **Land Disposal Restrictions (LDRs)** (40 CFR Part 268) are regulations prohibiting the disposal of hazardous waste on land without prior treatment. Under the LDRs program, materials must meet LDR treatment standards prior to placement in a RCRA land disposal unit (landfill, land treatment unit, waste pile, or surface impoundment). Generators of waste subject to the LDRs must provide notification of such to the designated TSD facility to ensure proper treatment prior to disposal.

- **Used Oil Management Standards** (40 CFR Part 279) impose management requirements affecting the storage, transportation, burning, processing, and re-refining of the used oil. For parties that merely generate used oil, regulations establish storage standards. For a party considered a used oil processor, re-refiner, burner, or marketer (one who generates and sells off-specification used oil), additional tracking and paperwork requirements

must be satisfied.

- RCRA contains unit-specific standards for all units used to store, treat, or dispose of hazardous waste, including **Tanks and Containers**. Tanks and containers used to store hazardous waste with a high volatile organic concentration must meet emission standards under RCRA. Regulations (40 CFR Part 264-265, Subpart CC) require generators to test the waste to determine the concentration of the waste, to satisfy tank and container emissions standards, and to inspect and monitor regulated units. These regulations apply to all facilities that store such waste, including large quantity generators accumulating waste prior to shipment off-site.

- Underground Storage Tanks** (USTs) containing petroleum and hazardous substances are regulated under Subtitle I of RCRA. Subtitle I regulations (40 CFR Part 280) contain tank design and release detection requirements, as well as financial responsibility and corrective action standards for USTs. The UST program also includes upgrade requirements for existing tanks that must be met by December 22, 1998.

- Boilers and Industrial Furnaces** (BIFs) that use or burn fuel containing hazardous waste must comply with design and operating standards. BIF regulations (40 CFR Part 266, Subpart H) address unit design, provide performance standards, require emissions monitoring, and restrict the type of waste that may be burned.

EPA's RCRA, Superfund and EPCRA Hotline, at (800) 424-9346, responds to questions and distributes guidance regarding all RCRA regulations. The RCRA Hotline operates weekdays from 9:00 a.m. to 6:00 p.m., ET, excluding Federal holidays.

Comprehensive Environmental Response, Compensation, and Liability Act

The Comprehensive Environmental Response, Compensation, and Liability Act (CERCLA), a 1980 law known commonly as Superfund, authorizes EPA to respond to releases, or threatened releases, of hazardous substances that may endanger public health, welfare, or the environment. CERCLA also enables EPA to force parties responsible for environmental contamination to clean it up or to reimburse the Superfund for response costs incurred by EPA. The Superfund Amendments and Reauthorization Act (SARA) of 1986 revised various sections of CERCLA, extended the taxing authority for the Superfund, and created a free-standing law, SARA Title III, also known as the Emergency Planning and Community Right-to-Know Act (EPCRA).

The CERCLA hazardous substance release reporting regulations (40 CFR

Part 302) direct the person in charge of a facility to report to the National Response Center (NRC) any environmental release of a hazardous substance which equals or exceeds a reportable quantity. Reportable quantities are listed in 40 CFR §302.4. A release report may trigger a response by EPA, or by one or more Federal or State emergency response authorities.

EPA implements hazardous substance responses according to procedures outlined in the National Oil and Hazardous Substances Pollution Contingency Plan (NCP) (40 CFR Part 300). The NCP includes provisions for permanent cleanups, known as remedial actions, and other cleanups referred to as removals. EPA generally takes remedial actions only at sites on the National Priorities List (NPL), which currently includes approximately 1300 sites. Both EPA and states can act at sites; however, EPA provides responsible parties the opportunity to conduct removal and remedial actions and encourages community involvement throughout the Superfund response process.

EPA's RCRA, Superfund and EPCRA Hotline, at (800) 424-9346, answers questions and references guidance pertaining to the Superfund program. The CERCLA Hotline operates weekdays from 9:00 a.m. to 6:00 p.m., ET, excluding Federal holidays.

Emergency Planning And Community Right-To-Know Act

The Superfund Amendments and Reauthorization Act (SARA) of 1986 created the Emergency Planning and Community Right-to-Know Act (EPCRA, also known as SARA Title III), a statute designed to improve community access to information about chemical hazards and to facilitate the development of chemical emergency response plans by State and local governments. EPCRA required the establishment of State emergency response commissions (SERCs), responsible for coordinating certain emergency response activities and for appointing local emergency planning committees (LEPCs).

EPCRA and the EPCRA regulations (40 CFR Parts 350-372) establish four types of reporting obligations for facilities which store or manage specified chemicals:

- EPCRA §302** requires facilities to notify the SERC and LEPC of the presence of any extremely hazardous substance (the list of such substances is in 40 CFR Part 355, Appendices A and B) if it has such substance in excess of the substance's threshold planning quantity, and directs the facility to appoint an emergency response coordinator.

- EPCRA §304** requires the facility to notify the SERC and the LEPC in the

event of a release equaling or exceeding the reportable quantity of a CERCLA hazardous substance or an EPCRA extremely hazardous substance.

•**EPCRA §311 and §312** require a facility at which a hazardous chemical, as defined by the Occupational Safety and Health Act, is present in an amount exceeding a specified threshold to submit to the SERC, LEPC and local fire department material safety data sheets (MSDSs) or lists of MSDS's and hazardous chemical inventory forms (also known as Tier I and II forms). This information helps the local government respond in the event of a spill or release of the chemical.

•**EPCRA §313** requires manufacturing facilities included in SIC codes 20 through 39, which have ten or more employees, and which manufacture, process, or use specified chemicals in amounts greater than threshold quantities, to submit an annual toxic chemical release report. This report, known commonly as the Form R, covers releases and transfers of toxic chemicals to various facilities and environmental media, and allows EPA to compile the national Toxic Release Inventory (TRI) database.

All information submitted pursuant to EPCRA regulations is publicly accessible, unless protected by a trade secret claim.

EPA's RCRA, Superfund and EPCRA Hotline, at (800) 424-9346, answers questions and distributes guidance regarding the emergency planning and community right-to-know regulations. The EPCRA Hotline operates weekdays from 9:00 a.m. to 6:00 p.m., ET, excluding Federal holidays.

Clean Water Act

The primary objective of the Federal Water Pollution Control Act, commonly referred to as the Clean Water Act (CWA), is to restore and maintain the chemical, physical, and biological integrity of the nation's surface waters. Pollutants regulated under the CWA include "priority" pollutants, including various toxic pollutants; "conventional" pollutants, such as biochemical oxygen demand (BOD), total suspended solids (TSS), fecal coliform, oil and grease, and pH; and "non-conventional" pollutants, including any pollutant not identified as either conventional or priority.

The CWA regulates both direct and indirect discharges. The National Pollutant Discharge Elimination System (NPDES) program (CWA §502) controls direct discharges into navigable waters. Direct discharges or "point source" discharges are from sources such as pipes and sewers. NPDES permits, issued by either EPA or an authorized State (EPA has authorized 42 States to administer the NPDES program), contain industry-specific,

technology-based and/or water quality-based limits, and establish pollutant monitoring requirements. A facility that intends to discharge into the nation's waters must obtain a permit prior to initiating its discharge. A permit applicant must provide quantitative analytical data identifying the types of pollutants present in the facility's effluent. The permit will then set the conditions and effluent limitations on the facility discharges.

A NPDES permit may also include discharge limits based on Federal or State water quality criteria or standards, that were designed to protect designated uses of surface waters, such as supporting aquatic life or recreation. These standards, unlike the technological standards, generally do not take into account technological feasibility or costs. Water quality criteria and standards vary from State to State, and site to site, depending on the use classification of the receiving body of water. Most States follow EPA guidelines which propose aquatic life and human health criteria for many of the 126 priority pollutants.

Storm Water Discharges

In 1987 the CWA was amended to require EPA to establish a program to address storm water discharges. In response, EPA promulgated the NPDES storm water permit application regulations. These regulations require that facilities with the following storm water discharges apply for an NPDES permit: (1) a discharge associated with industrial activity; (2) a discharge from a large or medium municipal storm sewer system; or (3) a discharge which EPA or the State determines to contribute to a violation of a water quality standard or is a significant contributor of pollutants to waters of the United States.

The term "storm water discharge associated with industrial activity" means a storm water discharge from one of 11 categories of industrial activity defined at 40 CFR 122.26. Six of the categories are defined by SIC codes while the other five are identified through narrative descriptions of the regulated industrial activity. If the primary SIC code of the facility is one of those identified in the regulations, the facility is subject to the storm water permit application requirements. If any activity at a facility is covered by one of the five narrative categories, storm water discharges from those areas where the activities occur are subject to storm water discharge permit application requirements.

Those facilities/activities that are subject to storm water discharge permit application requirements are identified below. To determine whether a particular facility falls within one of these categories, consult the regulation.

Category i: Facilities subject to storm water effluent guidelines, new source

performance standards, or toxic pollutant effluent standards.

Category ii: Facilities classified as SIC 24-lumber and wood products (except wood kitchen cabinets); SIC 26-paper and allied products (except paperboard containers and products); SIC 28-chemicals and allied products (except drugs and paints); SIC 291-petroleum refining; and SIC 311-leather tanning and finishing, 32 (except 323)-stone, clay, glass, and concrete, 33-primary metals, 3441-fabricated structural metal, and 373-ship and boat building and repairing.

Category iii: Facilities classified as SIC 10-metal mining; SIC 12-coal mining; SIC 13-oil and gas extraction; and SIC 14-nonmetallic mineral mining.

Category iv: Hazardous waste treatment, storage, or disposal facilities.

Category v: Landfills, land application sites, and open dumps that receive or have received industrial wastes.

Category vi: Facilities classified as SIC 5015-used motor vehicle parts; and SIC 5093-automotive scrap and waste material recycling facilities.

Category vii: Steam electric power generating facilities.

Category viii: Facilities classified as SIC 40-railroad transportation; SIC 41-local passenger transportation; SIC 42-trucking and warehousing (except public warehousing and storage); SIC 43-U.S. Postal Service; SIC 44-water transportation; SIC 45-transportation by air; and SIC 5171-petroleum bulk storage stations and terminals.

Category ix: Sewage treatment works.

Category x: Construction activities except operations that result in the disturbance of less than five acres of total land area.

Category xi: Facilities classified as SIC 20-food and kindred products; SIC 21-tobacco products; SIC 22-textile mill products; SIC 23-apparel related products; SIC 2434-wood kitchen cabinets manufacturing; SIC 25-furniture and fixtures; SIC 265-paperboard containers and boxes; SIC 267-converted paper and paperboard products; SIC 27-printing, publishing, and allied industries; SIC 283-drugs; SIC 285-paints, varnishes, lacquer, enamels, and allied products; SIC 30-rubber and plastics; SIC 31-leather and leather products (except leather and tanning and finishing); SIC 323-glass products; SIC 34-fabricated metal products (except fabricated structural metal); SIC 35-industrial and commercial machinery and computer equipment; SIC 36-

electronic and other electrical equipment and components; SIC 37-transportation equipment (except ship and boat building and repairing); SIC 38-measuring, analyzing, and controlling instruments; SIC 39-miscellaneous manufacturing industries; and SIC 4221-4225-public warehousing and storage.

Pretreatment Program

Another type of discharge that is regulated by the CWA is one that goes to a publicly-owned treatment works (POTWs). The national pretreatment program (CWA §307(b)) controls the indirect discharge of pollutants to POTWs by "industrial users." Facilities regulated under §307(b) must meet certain pretreatment standards. The goal of the pretreatment program is to protect municipal wastewater treatment plants from damage that may occur when hazardous, toxic, or other wastes are discharged into a sewer system and to protect the quality of sludge generated by these plants. Discharges to a POTW are regulated primarily by the POTW itself, rather than the State or EPA.

EPA has developed technology-based standards for industrial users of POTWs. Different standards apply to existing and new sources within each category. "Categorical" pretreatment standards applicable to an industry on a nationwide basis are developed by EPA. In addition, another kind of pretreatment standard, "local limits," are developed by the POTW in order to assist the POTW in achieving the effluent limitations in its NPDES permit.

Regardless of whether a State is authorized to implement either the NPDES or the pretreatment program, if it develops its own program, it may enforce requirements more stringent than Federal standards.

Spill Prevention, Control and Countermeasure Plans

The 1990 Oil Pollution Act requires that facilities that could reasonably be expected to discharge oil in harmful quantities prepare and implement more rigorous Spill Prevention Control and Countermeasure (SPCC) Plan required under the CWA (40 CFR §112.7). There are also criminal and civil penalties for deliberate or negligent spills of oil. Regulations covering response to oil discharges and contingency plans (40 CFR Part 300), and Facility Response Plans to oil discharges (40 CFR §112.20) and for PCB transformers and PCB-containing items were revised and finalized in 1995.

EPA's Office of Water, at (202) 260-5700, will direct callers with questions about the CWA to the appropriate EPA office. EPA also maintains a bibliographic database of Office of Water publications which can be accessed through the Ground Water and Drinking Water resource center, at (202) 260-7786.

Safe Drinking Water Act

The Safe Drinking Water Act (SDWA) mandates that EPA establish regulations to protect human health from contaminants in drinking water. The law authorizes EPA to develop national drinking water standards and to create a joint Federal-State system to ensure compliance with these standards. The SDWA also directs EPA to protect underground sources of drinking water through the control of underground injection of liquid wastes.

EPA has developed primary and secondary drinking water standards under its SDWA authority. EPA and authorized States enforce the primary drinking water standards, which are, contaminant-specific concentration limits that apply to certain public drinking water supplies. Primary drinking water standards consist of maximum contaminant level goals (MCLGs), which are non-enforceable health-based goals, and maximum contaminant levels (MCLs), which are enforceable limits set as close to MCLGs as possible, considering cost and feasibility of attainment.

The SDWA Underground Injection Control (UIC) program (40 CFR Parts 144-148) is a permit program which protects underground sources of drinking water by regulating five classes of injection wells. UIC permits include design, operating, inspection, and monitoring requirements. Wells used to inject hazardous wastes must also comply with RCRA corrective action standards in order to be granted a RCRA permit, and must meet applicable RCRA land disposal restrictions standards. The UIC permit program is primarily State-enforced, since EPA has authorized all but a few States to administer the program.

The SDWA also provides for a Federally-implemented Sole Source Aquifer program, which prohibits Federal funds from being expended on projects that may contaminate the sole or principal source of drinking water for a given area, and for a State-implemented Wellhead Protection program, designed to protect drinking water wells and drinking water recharge areas.

EPA's Safe Drinking Water Hotline, at (800) 426-4791, answers questions and distributes guidance pertaining to SDWA standards. The Hotline operates from 9:00 a.m. through 5:30 p.m., ET, excluding Federal holidays.

Toxic Substances Control Act

The Toxic Substances Control Act (TSCA) granted EPA authority to create a regulatory framework to collect data on chemicals in order to evaluate, assess, mitigate, and control risks which may be posed by their manufacture, processing, and use. TSCA provides a variety of control methods to prevent chemicals from posing unreasonable risk.

TSCA standards may apply at any point during a chemical's life cycle. Under TSCA §5, EPA has established an inventory of chemical substances. If a chemical is not already on the inventory, and has not been excluded by TSCA, a premanufacture notice (PMN) must be submitted to EPA prior to manufacture or import. The PMN must identify the chemical and provide available information on health and environmental effects. If available data are not sufficient to evaluate the chemicals effects, EPA can impose restrictions pending the development of information on its health and environmental effects. EPA can also restrict significant new uses of chemicals based upon factors such as the projected volume and use of the chemical.

Under TSCA §6, EPA can ban the manufacture or distribution in commerce, limit the use, require labeling, or place other restrictions on chemicals that pose unreasonable risks. Among the chemicals EPA regulates under §6 authority are asbestos, chlorofluorocarbons (CFCs), and polychlorinated biphenyls (PCBs).

EPA's TSCA Assistance Information Service, at (202) 554-1404, answers questions and distributes guidance pertaining to Toxic Substances Control Act standards. The Service operates from 8:30 a.m. through 4:30 p.m., ET, excluding Federal holidays.

Clean Air Act

The Clean Air Act (CAA) and its amendments, including the Clean Air Act Amendments (CAAA) of 1990, are designed to "protect and enhance the nation's air resources so as to promote the public health and welfare and the productive capacity of the population." The CAA consists of six sections, known as Titles, which direct EPA to establish national standards for ambient air quality and for EPA and the States to implement, maintain, and enforce these standards through a variety of mechanisms. Under the CAAA, many facilities will be required to obtain permits for the first time. State and local governments oversee, manage, and enforce many of the requirements of the CAAA. CAA regulations appear at 40 CFR Parts 50-99.

Pursuant to Title I of the CAA, EPA has established national ambient air quality standards (NAAQSs) to limit levels of "criteria pollutants," including carbon monoxide, lead, nitrogen dioxide, particulate matter, volatile organic compounds (VOCs), ozone, and sulfur dioxide. Geographic areas that meet NAAQSs for a given pollutant are classified as attainment areas; those that do not meet NAAQSs are classified as non-attainment areas. Under section 110 of the CAA, each State must develop a State Implementation Plan (SIP) to identify sources of air pollution and to determine what reductions are required to meet Federal air quality standards. Revised NAAQSs for particulates and ozone were proposed in 1996 and may go into effect as early as late 1997.

Title I also authorizes EPA to establish New Source Performance Standards (NSPSs), which are nationally uniform emission standards for new stationary sources falling within particular industrial categories. NSPSs are based on the pollution control technology available to that category of industrial source.

Under Title I, EPA establishes and enforces National Emission Standards for Hazardous Air Pollutants (NESHAPs), nationally uniform standards oriented towards controlling particular hazardous air pollutants (HAPs). Title I, section 112(c) of the CAA further directed EPA to develop a list of sources that emit any of 189 HAPs, and to develop regulations for these categories of sources. To date EPA has listed 174 categories and developed a schedule for the establishment of emission standards. The emission standards will be developed for both new and existing sources based on "maximum achievable control technology" (MACT). The MACT is defined as the control technology achieving the maximum degree of reduction in the emission of the HAPs, taking into account cost and other factors.

Title II of the CAA pertains to mobile sources, such as cars, trucks, buses, and planes. Reformulated gasoline, automobile pollution control devices, and vapor recovery nozzles on gas pumps are a few of the mechanisms EPA uses to regulate mobile air emission sources.

Title IV of the CAA establishes a sulfur dioxide nitrous oxide emissions program designed to reduce the formation of acid rain. Reduction of sulfur dioxide releases will be obtained by granting to certain sources limited emissions allowances, which, beginning in 1995, will be set below previous levels of sulfur dioxide releases.

Title V of the CAA of 1990 created a permit program for all "major sources" (and certain other sources) regulated under the CAA. One purpose of the operating permit is to include in a single document all air emissions requirements that apply to a given facility. States are developing the permit programs in accordance with guidance and regulations from EPA. Once a State program is approved by EPA, permits will be issued and monitored by that State.

Title VI of the CAA is intended to protect stratospheric ozone by phasing out the manufacture of ozone-depleting chemicals and restrict their use and distribution. Production of Class I substances, including 15 kinds of chlorofluorocarbons (CFCs) and chloroform, were phased out (except for essential uses) in 1996.

EPA's Clean Air Technology Center, at (919) 541-0800, provides general assistance and information on CAA standards. The Stratospheric Ozone Information Hotline, at (800) 296-1996, provides general information about regulations promulgated under Title VI of the CAA, and EPA's EPCRA

Hotline, at (800) 535-0202, answers questions about accidental release prevention under CAA §112(r). In addition, the Clean Air Technology Center's website includes recent CAA rules, EPA guidance documents, and updates of EPA activities (www.epa.gov/ttn then select Directory and then CATC).

VI.B. Industry Specific Requirements*Resource Conservation and Recovery Act (RCRA)*

Under the authority of RCRA, EPA created a regulatory framework that addresses the management of hazardous waste. The regulations address the generation, transport, storage, treatment, and disposal of hazardous waste.

The metal casting industry generates waste during molding and core making, melting operations, casting operations, and finishing and cleaning operations. The wastes that are produced during these processes which meet the RCRA hazardous waste criteria must be handled accordingly.

Molding and core making operations produce large quantities of spent foundry sand. Although most of the spent sand is non-hazardous, sand that results from the production of brass or bronze may exhibit the toxicity characteristic for lead or cadmium. The hazardous sand may be reclaimed in a thermal treatment unit which may be subject to RCRA requirements for hazardous waste incinerators. EPA is currently taking public comment on the regulatory status of these units. Wastewaters that are produced during molding and core making may exhibit the corrosivity characteristic but are generally discharged to a POTW after being neutralized, in which case they are not subject to RCRA. Sludges resulting from mold and core making may also be corrosive hazardous wastes.

The wastes associated with metal casting melting operations include fugitive dust and slag. Lead and chromium contamination may cause the waste slag to be subject to RCRA as a hazardous waste. Additionally, calcium carbide desulfurization slag generated during metal melting could be a reactive hazardous waste. Spent solvents used in the cleaning and degreasing of scrap metal prior to melting may also be a hazardous waste. The inorganic acids and chlorinated solvents used in the cleaning operations could be subject to RCRA as well, if they are spilled or disposed of prior to use.

Casting facilities that use electric arc furnaces (EAF) for metal melting produce dust and sludge that may be characteristically hazardous. However, the emission control dust and sludge from foundry operations that use EAFs is not within the K061 hazardous waste listing. Also, this dust and sludge is not considered to be a solid waste under RCRA when reclaimed.

Finishing operations produce wastes similar to those resulting from the cleaning and degreasing of scrap metal prior to melting, including spent solvents and alkaline cleaners. Additionally, any sludge from spent pickle liquor recovery generated by metal casting facilities (SIC code 332) would be a listed hazardous waste (K062).

Clean Air Act

The CAA New Source Review (NSR) requirements apply to new facilities, expansions of existing facilities, or process modifications. New sources of the NAAQS "criteria" pollutants in excess of "major" levels defined by EPA are subject to NSR requirements (40 CFR §52.21(b)(1)(i)(a)-(b)). NSRs are typically conducted by the state agency under standards set by EPA and adopted by the state as part of its state implementation plan (SIP). There are two types of NSRs: Prevention of Significant Deterioration (PSD) reviews for those areas that are meeting the NAAQS; and nonattainment (NA) reviews for areas that are violating the NAAQS. Permits are required to construct or operate the new source for PSD and NA areas.

For NA areas, permits require the new source to meet lowest achievable emission rate (LAER) standards and the operator of the new source must procure reductions in emissions of the same pollutants from other sources in the NA area in equal or greater amounts to the new source. These emission offsets may be banked and traded through state agencies.

For PSD areas, permits require the best available control technology (BACT), and the operator or owner of the new source must conduct continuous on-site air quality monitoring for one year prior to the new source addition to determine the effects that the new emissions may have on air quality.

EPA has not established New Source Performance Standards (NSPSs) for the metal casting industrial category.

Under Title V of the CAAA 1990 (40 CFR Parts 70-72) all of the applicable requirements of the Amendments are integrated into one federal renewable operating permit. Facilities defined as major sources under the Act must apply for permits within one year from when EPA approves the state permit programs. Since most state programs were not approved until after November 1994, Title V permits, for the most part, began to be due in late 1995. Due dates for filing complete applications vary from state to state, based on the status of review and approval of the state's Title V program by EPA.

A facility is designated as a major source if it includes sources subject to the NSPS acid rain provisions or NESHAPS, or if it releases a certain amount of any one of the CAAA regulated pollutants (SO_x , NO_x , CO, VOC, PM_{10} , hazardous air pollutants, extremely hazardous substances, ozone depleting substances, and pollutants covered by NSPSs) depending on the region's air quality category. Title V permits may set limits on the amounts of pollutant emissions and require emissions monitoring, recordkeeping, and reporting.

Many large and some medium-sized foundries are likely to be major sources and therefore must apply for a Title V permit. Selected small foundries may also be classified as major sources, depending on their location and

operational factors.

Clean Water Act

Foundry and die casting facility wastewater released to surface waters is regulated under the CWA (40 CFR Part 464). National Pollutant Discharge Elimination System (NPDES) permits must be obtained to discharge wastewater into navigable waters (40 Part 122). Effluent limitation guidelines, new source performance standards, pretreatment standards for new sources, and pretreatment standards for existing sources for the Metal Molding and Casting Point Source Category apply to ferrous and non-ferrous foundries and die casters and are listed under 40 CFR Part 464 and are divided into subparts according to the metal cast:

Subpart A	Applies to aluminum casting operations
Subpart B	Applies to copper casting operations
Subpart C	Applies to ferrous casting operations
Subpart D	Applies to zinc casting operations

In addition to the effluent guidelines, facilities that discharge to a POTW may be required to meet National Pretreatment Standards for some contaminants. General pretreatment standards applying to most industries discharging to a POTW are described in 40 CFR Part 403 (Contact Pat Bradley, EPA Office of Water, 202-260-6963). As shown above, pretreatment standards applying specifically to the metal casting point source category are listed in the subparts of 40 CFR Part 464 (Contact: George Jett, EPA Office of Water, 202-260-7151).

Stormwater rules require that metal casting facilities with the following storm water discharges apply for an NPDES permit: (1) a discharge associated with industrial activity; (2) a discharge from a large or medium municipal storm sewer system; or (3) a discharge which EPA or the State determines to contribute to a violation of a water quality standard or is a significant contributor of pollutants to waters of the United States. The term "storm water discharge associated with industrial activity" means a storm water discharge from one of 11 categories of industrial activity defined at 40 CFR 122.26. The rules require that certain facilities with storm water discharge from from industrial activity apply for storm water permit applications (see Section VI.A).

Comprehensive Environmental Response, Compensation, and Liability Act (CERCLA)

The Comprehensive Environmental Response, Compensation, and Liability Act (CERCLA) and the Superfund Amendments and Reauthorization Act of

1986 (SARA) provide the basic legal framework for the federal "Superfund" program to clean up abandoned hazardous waste sites (40 CFR Part 305). The metals and metal compounds used in metal casting, are often found in casting facilities' air emissions, water discharges, or waste shipments for off-site disposal. These include chromium, manganese, aluminum, nickel, copper, zinc, and lead. Metals are frequently found at CERCLA's problem sites. In 1989, when Congress ordered EPA and the Public Health Service's Agency for Toxic Substances and Disease Registry (ATSDR) to list the hazardous substances found most commonly at problem sites and that pose the greatest threat to human health, lead, nickel, and aluminum all made the list (Breen and Campbell-Mohn, 1993). A number of sites containing foundry wastes are on the National Priorities (Superfund) List. Compliance with the requirements of RCRA lessens the chances that CERCLA compliance will be an issue in the future.

VI.C. Pending and Proposed Regulatory Requirements

Resource Conservation and Recovery Act (RCRA)

Currently, the practice of adding iron dust or filings to spent foundry sand as a form of stabilization is subject to case-specific interpretation by EPA regarding whether this activity effectively treats the waste. However, EPA has proposed to regulate this activity as impermissible dilution, which is strictly prohibited under the land disposal restrictions program, and intends to examine the issue further.

Thermal processing or reclamation units (TRUs) remove contaminants from spent foundry sand primarily by combusting the organic binder materials in the sand. These units are identified as foundry furnaces under the definition of industrial furnace and are subject to regulation under 40 CFR Part 266, Subpart H when they burn hazardous waste. However, EPA did not consider whether TRUs would be appropriately controlled under these standards. EPA has proposed two approaches to ensure controls for TRUs. The first option is a deferral from regulation under 40 CFR Part 266, Subpart H. This would allow development of the foundry maximum achievable control technology under the Clean Air Act and potentially the application of these controls to TRUs that process hazardous waste sand. The second option is to provide a variance from the RCRA definition of solid waste. Under the variance provisions, EPA may grant a variance from the definition of solid waste for materials that are reclaimed and used as a feedstock within the original production process if the reclamation process is an essential part of the production process. Under this option, TRUs would not be subject to RCRA regulation, but could be regulated under the Clean Air Act or state or local air pollution laws (EPA, RCRA Hotline, 1997).

Clean Air Act

In addition to the CAA requirements discussed above, EPA is currently working on or will be working on additional regulations that will directly affect the metal casting industry. Under Title III, EPA is required to develop national standards for 189 hazardous air pollutants (HAPs) some of which are emitted from foundries. NESHAP standards may limit the air emissions from foundries through Maximum Achievable Control Technology (MACT) based on performance standards that will set limits based upon concentrations of HAPs in the waste stream. NESHAP standards for ferrous foundries are scheduled to be promulgated by EPA in November of 2000 (James Maysilles, U.S. EPA, Office of Air, (919) 541-3265). Non-ferrous foundries and die casting facilities will not be subject to NESHAP standards.

EPA is also developing the Compliance Assurance Monitoring Rule. The rule

may require monitoring of certain emissions from certain facilities. Facilities are required to pay a fee for filing for a permit and are required to pay an annual fee based on the magnitude of the facility's potential emissions.

VII. COMPLIANCE AND ENFORCEMENT HISTORY**Background**

Until recently, EPA has focused much of its attention on measuring compliance with specific environmental statutes. This approach allows the Agency to track compliance with the Clean Air Act, the Resource Conservation and Recovery Act, the Clean Water Act, and other environmental statutes. Within the last several years, the Agency has begun to supplement single-media compliance indicators with facility-specific, multimedia indicators of compliance. In doing so, EPA is in a better position to track compliance with all statutes at the facility level, and within specific industrial sectors.

A major step in building the capacity to compile multimedia data for industrial sectors was the creation of EPA's Integrated Data for Enforcement Analysis (IDEA) system. IDEA has the capacity to "read into" the Agency's single-media databases, extract compliance records, and match the records to individual facilities. The IDEA system can match Air, Water, Waste, Toxics/Pesticides/EPCRA, TRI, and Enforcement Docket records for a given facility, and generate a list of historical permit, inspection, and enforcement activity. IDEA also has the capability to analyze data by geographic area and corporate holder. As the capacity to generate multimedia compliance data improves, EPA will make available more in-depth compliance and enforcement information. Additionally, sector-specific measures of success for compliance assistance efforts are under development.

Compliance and Enforcement Profile Description

Using inspection, violation and enforcement data from the IDEA system, this section provides information regarding the historical compliance and enforcement activity of this sector. In order to mirror the facility universe reported in the Toxic Chemical Profile, the data reported within this section consists of records only from the TRI reporting universe. With this decision, the selection criteria are consistent across sectors with certain exceptions. For the sectors that do not normally report to the TRI program, data have been provided from EPA's Facility Indexing System (FINDS) which tracks facilities in all media databases. Please note, in this section, EPA does not attempt to define the actual number of facilities that fall within each sector. Instead, the section portrays the records of a subset of facilities within the sector that are well defined within EPA databases.

As a check on the relative size of the full sector universe, most notebooks contain an estimated number of facilities within the sector according to the Bureau of Census (See Section II). With sectors dominated by small businesses, such as metal finishers and printers, the reporting universe within

the EPA databases may be small in comparison to Census data. However, the group selected for inclusion in this data analysis section should be consistent with this sector's general make-up.

Following this introduction is a list defining each data column presented within this section. These values represent a retrospective summary of inspections and enforcement actions, and reflect solely EPA, State, and local compliance assurance activities that have been entered into EPA databases. To identify any changes in trends, the EPA ran two data queries, one for the past five calendar years (April 1, 1992 to March 31, 1997) and the other for the most recent twelve-month period (April 1, 1996 to March 31, 1997). The five-year analysis gives an average level of activity for that period for comparison to the more recent activity.

Because most inspections focus on single-media requirements, the data queries presented in this section are taken from single media databases. These databases do not provide data on whether inspections are state/local or EPA-led. However, the table breaking down the universe of violations does give the reader a crude measurement of the EPA's and states' efforts within each media program. The presented data illustrate the variations across EPA Regions for certain sectors.⁴ This variation may be attributable to state/local data entry variations, specific geographic concentrations, proximity to population centers, sensitive ecosystems, highly toxic chemicals used in production, or historical noncompliance. Hence, the exhibited data do not rank regional performance or necessarily reflect which regions may have the most compliance problems.

Compliance and Enforcement Data Definitions

General Definitions

Facility Indexing System (FINDS) -- this system assigns a common facility number to EPA single-media permit records. The FINDS identification number allows EPA to compile and review all permit, compliance, enforcement and pollutant release data for any given regulated facility.

Integrated Data for Enforcement Analysis (IDEA) -- is a data integration system that can retrieve information from the major EPA program office databases. IDEA uses the FINDS identification number to link separate data records from EPA's databases. This allows retrieval of records from across

⁴ EPA Regions include the following states: I (CT, MA, ME, RI, NH, VT); II (NJ, NY, PR, VI); III (DC, DE, MD, PA, VA, WV); IV (AL, FL, GA, KY, MS, NC, SC, TN); V (IL, IN, MI, MN, OH, WI); VI (AR, LA, NM, OK, TX); VII (IA, KS, MO, NE); VIII (CO, MT, ND, SD, UT, WY); IX (AZ, CA, HI, NV, Pacific Trust Territories); X (AK, ID, OR, WA).

media or statutes for any given facility, thus creating a "master list" of records for that facility. Some of the data systems accessible through IDEA are: AIRS (Air Facility Indexing and Retrieval System, Office of Air and Radiation), PCS (Permit Compliance System, Office of Water), RCRIS (Resource Conservation and Recovery Information System, Office of Solid Waste), NCDB (National Compliance Data Base, Office of Prevention, Pesticides, and Toxic Substances), CERCLIS (Comprehensive Environmental and Liability Information System, Superfund), and TRIS (Toxic Release Inventory System). IDEA also contains information from outside sources such as Dun and Bradstreet and the Occupational Safety and Health Administration (OSHA). Most data queries displayed in notebook sections IV and VII were conducted using IDEA.

Data Table Column Heading Definitions

Facilities in Search -- are based on the universe of TRI reporters within the listed SIC code range. For industries not covered under TRI reporting requirements (metal mining, nonmetallic mineral mining, electric power generation, ground transportation, water transportation, and dry cleaning), or industries in which only a very small fraction of facilities report to TRI (e.g., printing), the notebook uses the FINDS universe for executing data queries. The SIC code range selected for each search is defined by each notebook's selected SIC code coverage described in Section II.

Facilities Inspected --- indicates the level of EPA and state agency inspections for the facilities in this data search. These values show what percentage of the facility universe is inspected in a one-year or five-year period.

Number of Inspections -- measures the total number of inspections conducted in this sector. An inspection event is counted each time it is entered into a single media database.

Average Time Between Inspections -- provides an average length of time, expressed in months, between compliance inspections at a facility within the defined universe.

Facilities with One or More Enforcement Actions -- expresses the number of facilities that were the subject of at least one enforcement action within the defined time period. This category is broken down further into federal and state actions. Data are obtained for administrative, civil/judicial, and criminal enforcement actions. Administrative actions include Notices of Violation (NOVs). A facility with multiple enforcement actions is only counted once in this column, e.g., a facility with 3 enforcement actions counts as 1 facility.

Total Enforcement Actions -- describes the total number of enforcement actions identified for an industrial sector across all environmental statutes. A facility with multiple enforcement actions is counted multiple times, e.g., a facility with 3 enforcement actions counts as 3.

State Lead Actions -- shows what percentage of the total enforcement actions are taken by state and local environmental agencies. Varying levels of use by states of EPA data systems may limit the volume of actions recorded as state enforcement activity. Some states extensively report enforcement activities into EPA data systems, while other states may use their own data systems.

Federal Lead Actions -- shows what percentage of the total enforcement actions are taken by the United States Environmental Protection Agency. This value includes referrals from state agencies. Many of these actions result from coordinated or joint state/federal efforts.

Enforcement to Inspection Rate -- is a ratio of enforcement actions to inspections, and is presented for comparative purposes only. This ratio is a rough indicator of the relationship between inspections and enforcement. It relates the number of enforcement actions and the number of inspections that occurred within the one-year or five-year period. This ratio includes the inspections and enforcement actions reported under the Clean Water Act (CWA), the Clean Air Act (CAA) and the Resource Conservation and Recovery Act (RCRA). Inspections and actions from the TSCA/FIFRA/EPCRA database are not factored into this ratio because most of the actions taken under these programs are not the result of facility inspections. Also, this ratio does not account for enforcement actions arising from non-inspection compliance monitoring activities (e.g., self-reported water discharges) that can result in enforcement action within the CAA, CWA, and RCRA.

Facilities with One or More Violations Identified -- indicates the percentage of inspected facilities having a violation identified in one of the following data categories: In Violation or Significant Violation Status (CAA); Reportable Noncompliance, Current Year Noncompliance, Significant Noncompliance (CWA); Noncompliance and Significant Noncompliance (FIFRA, TSCA, and EPCRA); Unresolved Violation and Unresolved High Priority Violation (RCRA). The values presented for this column reflect the extent of noncompliance within the measured time frame, but do not distinguish between the severity of the noncompliance. Violation status may be a precursor to an enforcement action, but does not necessarily indicate that an enforcement action will occur.

Media Breakdown of Enforcement Actions and Inspections -- four columns identify the proportion of total inspections and enforcement actions within EPA Air, Water, Waste, and FIFRA/TSCA/EPCRA databases. Each column is a percentage of either the "Total Inspections," or the "Total Actions" column.

VII.A. Metal Casting Industry Compliance History

Table 15 provides an overview of the reported compliance and enforcement data for the metal casting industry over the past five years (April 1992 to April 1997). These data are also broken out by EPA Regions thereby permitting geographical comparisons. A few points evident from the data are listed below.

- Almost 80 percent of metal casting facility inspections and 63 percent of enforcement actions occurred in Regions III, IV, and V, where most facilities (68 percent) are located.
- Region X had a high ratio of enforcement to inspections (0.40) compared to other Regions.
- Region IX had a significantly higher average time between inspections (70 months), which means that fewer inspections were carried out in relation to the number of facilities in the Region (54 facilities and 40 inspections).
- Region IV had the shortest average time between inspections (9 months), but also had the lowest rate of enforcement actions to inspections of any Region (0.05).

Table 15: Five-Year Enforcement and Compliance Summary for the Metal Casting Industry

A	B	C	D	E	F	G	H	I	J
Region	Facilities in Search	Facilities Inspected	Number of Inspections	Average Months Between Inspections	Facilities with 1 or More Enforcement Actions	Total Enforcement Actions	Percent State Lead Actions	Percent Federal Lead Actions	Enforcement to Inspection Rate
I	15	8	44	20	2	3	67%	33%	0.07
II	26	16	128	12	10	19	68%	32%	0.15
III	74	61	458	10	19	29	83%	17%	0.06
IV	77	53	505	9	12	24	88%	12%	0.05
V	307	191	1,026	18	45	68	63%	37%	0.07
VI	44	25	103	26	6	14	43%	57%	0.14
VII	40	33	167	14	6	10	30%	70%	0.06
VIII	9	7	16	34	2	2	100%	0%	0.13
IX	54	15	46	70	4	5	100%	0%	0.11
X	23	15	42	33	7	17	94%	6%	0.40
TOTAL	669	424	2,535	16	113	191	71%	29%	0.08

VII.BC Comparison of Enforcement Activity Between Selected Industries

Tables 16 and 17 allow the compliance history of the metal casting sector to be compared to the other industries covered by the industry sector notebooks. Comparisons between Tables 16 and 17 permit the identification of trends in compliance and enforcement records of the various industries by comparing data covering the last five years (April 1992 to April 1997) to that of the past year (April 1996 to April 1997). Some points evident from the data are listed below.

- Over the past year, the industry has had one of the highest proportions of facilities inspected with violations (103 percent) and enforcement actions (10 percent).
- Over the past year, the average enforcement to inspection rate for the metal casting industry has decreased to 0.06 compared to 0.08 over the past five years.
- Of the sectors listed, facilities in the metal casting sector had one of the highest proportions of federal-lead enforcement actions (29 percent).

Tables 18 and 19 provide a more in-depth comparison between the metal casting industry and other sectors by breaking out the compliance and enforcement data by environmental statute. As in the previous Tables (Tables 16 and 17), the data cover the last five years (Table 18) and the last one year (Table 19) to facilitate the identification of recent trends. A few points evident from the data are listed below.

- The percentage of inspections carried out under each environmental statute has changed little over the past five years compared to the past year. Inspections under CAA account for the majority (about 60 percent) followed by RCRA and CWA.
- The percentage of CAA enforcement actions increased from 44 percent over the past five years to 58 percent over the past year. In addition, the percentage of enforcement actions carried under FIFRA/TSCA/EPCRA/Other decreased from 14 percent to 0 percent while CWA and RCRA remained about the same.

Table 16: Five-Year Enforcement and Compliance Summary for Selected Industries

A	B	C	D	E	F	G	H	I	J
Industry Sector	Facilities in Search	Facilities Inspected	Number of Inspections	Average Months Between Inspections	Facilities with 1 or More Enforcement Actions	Total Enforcement Actions	Percent State Lead Actions	Percent Federal Lead Actions	Enforcement to Inspection Rate
Metal Mining	1,232	378	1,600	46	63	111	53%	47%	0.07
Coal Mining	3,256	741	3,748	52	88	132	89%	11%	0.04
Oil and Gas Extraction	4,676	1,902	6,071	46	149	309	79%	21%	0.05
Non-Metallic Mineral Mining	5,256	2,803	12,826	25	385	622	77%	23%	0.05
Textiles	355	267	1,465	15	53	83	90%	10%	0.06
Lumber and Wood	712	473	2,767	15	134	265	70%	30%	0.10
Furniture	499	386	2,379	13	65	91	81%	19%	0.04
Pulp and Paper	484	430	4,630	6	150	478	80%	20%	0.10
Printing	5,862	2,092	7,691	46	238	428	88%	12%	0.06
Inorganic Chemicals	441	286	3,087	9	89	235	74%	26%	0.08
Resins and Manmade Fibers	329	263	2,430	8	93	219	76%	24%	0.09
Pharmaceuticals	164	129	1,201	8	35	122	80%	20%	0.10
Organic Chemicals	425	355	4,294	6	153	468	65%	35%	0.11
Agricultural Chemicals	263	164	1,293	12	47	102	74%	26%	0.08
Petroleum Refining	156	148	3,081	3	124	763	68%	32%	0.25
Rubber and Plastic	1,818	981	4,383	25	178	276	82%	18%	0.06
Stone, Clay, Glass and Concrete	615	388	3,474	11	97	277	75%	25%	0.08
Iron and Steel	349	275	4,476	5	121	305	71%	29%	0.07
Metal Castings	669	424	2,535	16	113	191	71%	29%	0.08
Nonferrous Metals	203	161	1,640	7	68	174	78%	22%	0.11
Fabricated Metal Products	2,906	1,858	7,914	22	365	600	75%	25%	0.08
Electronics	1,250	863	4,500	17	150	251	80%	20%	0.06
Automobile Assembly	1,260	927	5,912	13	253	413	82%	18%	0.07
Shipbuilding and Repair	44	37	243	9	20	32	84%	16%	0.13
Ground Transportation	7,786	3,263	12,904	36	375	774	84%	16%	0.06
Water Transportation	514	192	816	38	36	70	61%	39%	0.09
Air Transportation	444	231	973	27	48	97	88%	12%	0.10
Fossil Fuel Electric Power	3,270	2,166	14,210	14	403	789	76%	24%	0.06
Dry Cleaning	6,063	2,360	3,813	95	55	66	95%	5%	0.02

Table 17: One-Year Enforcement and Compliance Summary for Selected Industries
Table 18: Five-Year Inspection and Enforcement Summary by Statute for Selected Industries

Industry Sector	Facilities Inspected	Facilities in Compliance	Total Facilities Inspected	Total Number of Enforcement Actions	Clean Air Act (CAA)				Resource Conservation and Recovery Act (RCRA)				FIFRA/FSCA/EPCRA/Other		Enforcement Rate						
					Total Number of Total Inspections	% of Total Inspections	% of Total Inspections	% of Total Inspections	Total Number of Enforcement Actions	% of Total Inspections	Total Number of Enforcement Actions	% of Total Inspections	Total Number of Enforcement Actions	% of Total Inspections							
Metal Mining	232	1,600	142	211	765	39%	90	19%	25%	52%	52%	20	8%	6%	12%	22	1%	17%	0.05		
Metal Mining - Coal Mining	378	2,256	1,600	362	1,111	765	39%	90	19%	25%	52%	20	8%	6%	12%	22	1%	17%	0.03		
Coal Mining - Gas Extraction	741	4,676	3,748	874	1,322	1,173	57%	127	14%	15%	38%	28	4%	3%	8%	34	1%	1%	0.03		
Coal Mining - Non-Metallic Mineral Mining	1,902	12,256	6,071	481	309	2,451	75%	384	15%	26%	16%	14	7%	3%	18%	91	0%	3%	0.04		
Non-Metallic Mineral Mining - Textiles	2,803	355	12,826	172	622	295	83%	96	1%	56%	14%	13	1%	3%	4%	12	0%	3%	0.04		
Textiles - Lumber and Wood	267	712	1,465	279	83	507	58%	192	4%	69%	22%	25	4%	1%	14%	52	2%	6%	0.10		
Lumber and Wood - Paper and Paper	473	499	2,767	254	265	459	49%	136	7%	54%	6%	6	6%	4%	31%	11	1%	16%	0.02		
Pulp and Paper - Paper	386	484	2,379	317	91	788	62%	248	2%	78%	3%	0	4%	3%	43%	74	1%	14%	0.09		
Pulp and Paper - Organic Chemicals	430	862	4,630	892	478	1,363	51%	577	9%	65%	32%	28	8%	10%	53	2%	4%	0.04			
Pharmaceuticals - Organic Chemicals	2,092	441	7,691	200	428	548	60%	155	4%	78%	5%	3	1%	3%	29%	31	1%	4%	0.06		
Pharmaceuticals - Plastics and Manmade Fibers	286	329	3,087	173	235	419	38%	152	4%	88%	27%	21	2%	6%	34%	5	30%	36	1%	5%	0.09
Pharmaceuticals - Resins and Manmade Fibers	263	164	2,430	80	219	209	35%	84	3%	105%	23%	28	8%	3%	23%	14	4%	6%	0.07		
Pharmaceuticals - Organic Chemicals	129	425	1,201	259	122	837	35%	243	9%	94%	15%	25	4%	2%	20%	56	5%	5%	0.07		
Chemicals - Organic Chemicals	355	263	4,294	105	468	206	37%	102	2%	97%	16%	25	5%	4%	28%	11	4%	6%	0.05		
Agriculture - Agricultural Chemicals	164	156	1,293	132	102	565	43%	129	9%	98%	24%	20	5%	8%	30%	132	5%	11%	0.23		
Plastics - Plastics and Paper	148	818	3,081	466	763	791	42%	389	9%	83%	20%	13	3%	3%	21%	41	2%	7%	0.05		
Rubber and Glass - Glass and Concrete	981	615	4,383	255	276	678	51%	151	4%	59%	12%	11	1%	1%	34%	27	2%	11%	0.04		
Stone, Clay, Glass and Concrete - Stone, Clay, Glass and Concrete	388	349	3,474	197	277	866	56%	174	7%	88%	13%	9	2%	2%	30%	34	1%	4%	0.04		
Iron and Steel - Metal Castings	275	669	4,476	234	305	433	45%	240	5%	103%	26%	26	2%	2%	31%	26	1%	8%	0.06		
Metal Castings - Metals	424	203	2,535	108	191	310	55%	98	4%	91%	11%	10	4%	7%	32%	16	3%	14%	0.09		
Non-Ferrous Metal - Non-Ferrous Metal	161	906	1,640	849	174	1,377	48%	796	3%	94%	18%	17	6%	3%	31%	83	1%	10%	0.06		
Fabricated Metal - Fabricated Metal	1,858	1,250	7,914	420	600	780	40%	402	3%	96%	12%	11	2%	7%	45%	43	2%	13%	0.06		
Automobile Assembly - Automobile Assembly	863	1,260	4,500	507	251	1,058	38%	431	2%	85%	13%	11	8%	5%	47%	47	2%	7%	0.04		
Automobile Assembly and Repair - Automobile Assembly and Repair	927	44	5,912	22	413	51	47%	19	9%	86%	8%	9	3%	3%	43%	4	2%	9%	0.08		
Shipbuilding and Repair - Shipbuilding and Repair	37	786	243	585	32	2,499	39%	681	5%	43%	14%	25	8%	5%	47%	103	5%	3%	0.04		
Ground Transportation - Ground Transportation	3,263	514	12,904	84	774	141	59%	53	1%	63%	12%	11	1%	0%	45%	11	1%	3%	0.08		
Water Transportation - Water Transportation	192	444	816	96	70	151	39%	69	9%	72%	23%	34	8%	3%	33%	12	1%	4%	0.08		
Electric Power - Electric Power	231	1,270	973	318	97	2,430	25%	804	2%	61%	27%	20	1%	0%	48%	135	0%	0%	0.06		
Fossil Fuel Electric Power - Fossil Fuel Electric Power	2,166	1,063	14,210	234	789	1,436	57%	314	9%	25%	32%	26	4%	2%	10%	16	1%	5%	0.01		
Dry Cleaning - Dry Cleaning	2,360	3,813	66	66	66	56%	3%	2%	3%	3%	6%	41%	100%	71%	100%	0%	0%	0%	0%		

occur without a facility inspection.

Table 19: One-Year Inspection and Enforcement Summary by Statute for Selected Industries

Industry Sector	Facilities Inspected	Total Inspections	Total Enforcement Actions	Clean Air Act		Clean Water Act		RCRA		FIFRA/TSCA/EPCRA/Other	
				% of Total Inspections	% of Total Actions	% of Total Inspections	% of Total Actions	% of Total Inspections	% of Total Actions	% of Total Inspections	% of Total Actions
Metal Mining	142	211	10	52%	0%	40%	40%	8%	30%	0%	30%
Coal Mining	362	765	22	56%	82%	40%	14%	4%	5%	0%	0%
Oil and Gas Extraction	874	1,173	34	82%	68%	10%	9%	9%	24%	0%	0%
Non-Metallic Mineral Mining	1,481	2,451	91	87%	89%	10%	9%	3%	2%	0%	0%
Textiles	172	295	12	66%	75%	17%	17%	17%	8%	0%	0%
Lumber and Wood	279	507	52	51%	30%	6%	5%	44%	25%	0%	40%
Furniture	254	459	11	66%	45%	2%	0%	32%	45%	0%	9%
Pulp and Paper	317	788	74	54%	73%	32%	19%	14%	7%	0%	1%
Printing	892	1,363	53	63%	77%	4%	0%	33%	23%	0%	0%
Inorganic Chemicals	200	548	31	35%	59%	26%	9%	39%	25%	0%	6%
Resins and Manmade Fibers	173	419	36	38%	51%	24%	38%	38%	5%	0%	5%
Pharmaceuticals	80	209	14	43%	71%	11%	14%	45%	14%	0%	0%
Organic Chemicals	259	837	56	40%	54%	13%	13%	47%	34%	0%	0%
Agricultural Chemicals	105	206	11	48%	55%	22%	0%	30%	36%	0%	9%
Petroleum Refining	132	565	132	49%	67%	17%	8%	34%	15%	0%	10%
Rubber and Plastic	466	791	41	55%	64%	10%	13%	35%	23%	0%	0%
Stone, Clay, Glass and Concrete	255	678	27	62%	63%	10%	7%	28%	30%	0%	0%
Iron and Steel	197	866	34	52%	47%	23%	29%	26%	24%	0%	0%
Metal Castings	234	433	26	60%	58%	10%	8%	30%	35%	0%	0%
Nonferrous Metals	108	310	28	44%	43%	15%	20%	41%	30%	0%	7%
Fabricated Metal	849	1,377	83	46%	41%	11%	2%	43%	57%	0%	0%
Electronics	420	780	43	44%	37%	14%	5%	43%	53%	0%	5%
Automobile Assembly	507	1,058	47	53%	47%	7%	6%	41%	47%	0%	0%
Shipbuilding and Repair	22	51	4	54%	0%	11%	50%	35%	50%	0%	0%
Ground Transportation	1,585	2,499	103	64%	46%	11%	10%	26%	44%	0%	1%
Water Transportation	84	141	11	38%	9%	24%	36%	38%	45%	0%	9%
Air Transportation	96	151	12	28%	33%	15%	42%	57%	25%	0%	0%
Fossil Fuel Electric Power	1,318	2,430	135	59%	73%	32%	21%	9%	5%	0%	0%
Dry Cleaning	1,234	1,436	16	62%	56%	1%	6%	30%	38%	0%	0%

VII.C. Review of Major Legal Actions

Major Cases/Supplemental Environmental Projects

This section provides summary information about major cases that have affected this sector, and a list of Supplemental Environmental Projects (SEPs).

VII.C.1. Review of Major Cases

As indicated in EPA's *Enforcement Accomplishments Report, FY1995 and FY1996* publications, 8 significant enforcement actions were resolved between 1995 and 1996 for the metal casting industry.

EMI Company (Pennsylvania): On May 29, 1996, EPA executed a consent agreement and order settling an administrative action against EMI Company for payment of \$20,000 and agreement to perform a Supplemental Environmental Project (SEP). The SEP requires respondent to install and operate (for one (1) year) baghouse emissions control technology for four (4) electric induction furnaces presently not subject to Best Available Control Technology (BAT) control requirements. The total SEP capital costs and operating expenditure costs for one year are estimated to be at least \$786,664. Those particulates include some of the regulated materials (copper and manganese) that are the subject of this action. Region III filed the administrative complaint against EMI Company of Erie, Pennsylvania for EPCRA reporting violations.

Leggett and Platt (Grafton, Wisconsin): On Monday, April 1, 1996, a consent decree was entered in the Milwaukee Federal court with Leggett & Platt, concerning their Grafton, WI, facilities (2). A penalty of \$450,000 was stipulated in the decree based on four years of reporting failures and exceeding the Federal Pretreatment standards for the Metal Molding and Casting industry. Also, the company agreed in the consent decree not to discharge process wastes to the Grafton POTW. As a result of this stipulation the company started a water recycle system in April, 1995, with several levels of plant water cleanliness. After several months of experimentation the company observed that the recycle system had a two-year payout due to the reduction of the use of plant lubricants. The yearly savings were in excess of \$50,000/year. Therefore, there was no economic benefit available for recovery.

Cooper Cameron (Richmond, Texas): This enforcement action arose out of the Region VI Foundry Initiative. EPA conducted an inspection of the Cooper Industries, Inc., Oil Tool Division in Richmond, Texas on September 21-23, 1994. At that facility, the Cooper Oil Tool Division manufactured a

variety of low and high carbon steel and stainless steel oil tool castings for valves and other equipment. During the inspection, EPA discovered a waste pile which contained Electric Arc Furnace (EAF) baghouse dust. This material was sampled using the TCLP method and was found to contain chromium (D007) above the 5.0 mg/L regulatory level. Therefore, the EAF baghouse dust is a hazardous waste. Cooper Oil Tool Division was acquired by Cooper Cameron Corporation which was spun off from Cooper Industries, Inc. in 1995. As the corporate successor to the Oil Tool Division, Cooper Cameron became responsible for the cited violations. Region VI simultaneously filed the consent agreement/consent order on September 30, 1996, assessing a civil penalty of \$45,000 plus injunctive relief. Additionally, Cooper Cameron has agreed to remediate, under the Texas Natural Resource Conservation Commission (TNRCC) Voluntary Cleanup Program, approximately 30 acres of waste materials stored in piles on their site. It is estimated that this action will reduce the risk of releasing more than 100 tons of chromium contaminated soil. The agreement to remediate the waste pile is a result of concern over environmental justice. The surrounding community is approximately 51% minority while Texas' average is 39%.

HICA Steel Foundry and Upgrade Co. (Shreveport, Louisiana): On November 7, 1995, EPA issued HICA Steel Foundry and Upgrade Company an administrative order (complaint). The order proposed a \$472,000 fine and required closure of several unauthorized hazardous waste management units. This action required the removal and proper disposal of 2,600 gallons on corrosive and ignitable hazardous waste and 255 tons of lead and chromium contaminated waste from the facility.

NIBCO, Inc. (Blytheville, Arkansas): A final consent agreement/consent order was signed by both Region VI and NIBCO on September 30, 1996. NIBCO agreed to pay \$750,000 in cash to satisfy the approximately \$2.5 million in civil penalties assessed by Region VI in this Foundry Initiative enforcement action. The enforcement action against NIBCO originated because the facility was treating sand used in the casting of metal valves (casting sand) with metallic iron dust, without a permit, and disposing of the material in the Nacogdoches municipal landfill. The casting sand absorbs lead during the casting process, making it a hazardous waste. In order to offset the civil penalty, NIBCO agreed to work with Texas Natural Resource Conservation Commission (TNRCC) and the City of Nacogdoches to characterize the foundry sand waste disposed of in the Nacogdoches municipal landfill, and ensure closure and post-closure measures are performed in accordance with all applicable requirements and schedules established by TNRCC.

Lynchburg Foundry Company (Lynchburg, VA): On August 24, 1995, the Region III Administrator signed a consent order which requires Lynchburg Foundry Company to perform tasks set out in the compliance section of the consent agreement, and to pay \$330,000 to EPA. Lynchburg, located in Lynchburg, Virginia, operates two facilities: Radford and Archer Creek, both of which manufacture metal automotive parts. Under the terms of the consent agreement and order, Lynchburg must: 1) list all hazardous wastes handled at both facilities within its hazardous waste notification filed with the Virginia Department of Hazardous Waste; 2) amend or supplement its emergency contingency plans for both facilities to reflect the arrangements agreed to by local emergency services; and 3) permanently cease illegally storing or treating D006 and D008 hazardous wastes in waste piles at either facility.

Great Lakes Casting Corporation (Ludington, MI): On November 15, 1994, a consent decree was entered in the U.S. District Court for the Western District of Michigan in the *U.S. v. Great Lakes Casting Corporation* case requiring Great Lakes to pay a civil penalty of \$350,000 for illegal hazardous waste disposal under RCRA.

CMI-Cast Parts, Inc. (Cadillac, MI): A consent agreement and final order was signed on December 22, 1994, which settled an administrative complaint against CMI-Cast Parts, Inc. CMI-Cast Parts, Inc. is a Michigan corporation which owns and operates an iron foundry in Cadillac, Michigan. CMI-Cast Parts, Inc. failed to obtain interim status or a proper operating permit to treat, store or dispose of hazardous waste at its Cadillac facility. From September 1990 to January 1994, the facility failed to comply with the hazardous waste management standards. On January 26, 1995, CMI-Cast Parts, Inc., submitted a certified check in the amount of \$454,600.00, payable to the Treasurer of the United States of America, for final settlement of the enforcement action.

VII.C.2. Supplementary Environmental Projects (SEPs)

SEPs are compliance agreements that reduce a facility's non-compliance penalty in return for an environmental project that exceeds the value of the reduction. Often, these projects fund pollution prevention activities that can reduce the future pollutant loadings of a facility. Information on SEP cases can be accessed via the Internet at EPA's Enviro\$en\$e Website: <http://es.inel.gov/sep>.

VIII. COMPLIANCE ASSURANCE ACTIVITIES AND INITIATIVES

This section highlights the activities undertaken by this industry sector and public agencies to voluntarily improve the sector's environmental performance. These activities include those initiated independently by industrial trade associations. In this section, the notebook also contains a listing and description of national and regional trade associations.

VIII.A. Sector-related Environmental Programs and Activities

VIII.A.1. Federal Activities

Metalcasting Competitiveness Research (MCR) Program

The U.S. Department of Energy (DOE) Metalcasting Competitiveness Research Act (Public Law 101-425) was signed in 1990 and established the U.S. DOE, Office of Industrial Technology Metalcasting Competitiveness Research (MCR) Program. The program provides assistance to the metalcasting industry by fostering R&D in technology areas that were identified as priority in nature by the industry including technology competitiveness and energy efficiency. In this program, industry and the DOE provide cost-share funding to metalcasting research institutions that conduct the R&D. Projects are chosen based on a set of research priorities developed by the Metalcasting Industrial Advisory Board (IAB). The IAB meets once a year to revise these priorities. As of 1996, 24 projects have been funded through the MCR Program, a number of them having direct and indirect benefits to the environment.

Casting Emission Reduction Program

The Casting Emission Reduction Program (CERP) is primarily focused on developing new materials, processes or equipment for metalcasting manufacturing which will achieve a near-zero effect on the environment while producing high quality components for the U.S. military and other users. The program also has the objective of bridging the critical gap between laboratory and full scale casting production. The result will be a platform for proofing and validating the next generation of light weight weapon system components using near net shape metal castings.

The program was initiated by the Department of Defense (DoD) in response to the rapid reduction in domestic foundries capable of producing the critical components of military hardware. These parts range from tank tracks and turrets to the tail structure of the F-16 fighter. The DoD sees an immediate threat to sand casting foundries and their ability to withstand the changes resulting from the Titles III and V Amendments to the 1990 Clean Air Act. In addition, DoD realizes that the needs of the military for post year 2000

hardware will depend on manufacturing technologies which do not exist today or are unable to make the transition from the lab bench to the shop floor. CERP aims to provide the country with the ability to launch lighter weight castings more quickly and at the same time meet the more demanding environmental regulations of the 1990 Clean Air Act Amendments. Although the program was initiated to address military needs, it is anticipated that it will benefit the entire industry.

The specific activities of CERP will include obtaining a baseline of emissions from foundries across the U.S., developing a pilot foundry at McClellan AFB in California for the testing and prototyping of new casting processes and materials, and developing the real-time emission instrumentation for foundries. The five-year program receives Congressional appropriations under the Research, Development, Test & Defense Wide category. Other technical partners directly supporting the project include the American Foundrymen's Society, the U.S. Environmental Protection Agency (EPA), the California Air Resources Board (CARB), and the U.S. Council for Automotive Research (USCAR). Contact: Bill Walden, (916) 643-1090.

EPA Region VI Foundry Initiative

EPA's Region VI (Oklahoma, Texas, Louisiana, Arkansas, New Mexico) began a Foundry Initiative in 1993 to improve compliance rates among the 600 foundries in the region. An initial inspection of 27 foundries in the Region indicated that a large percentage had potential RCRA violations. Region VI formed a partnership with the States and the American Foundrymen's Society to develop an initiative for environmental compliance which would be beneficial to foundries. EPA, the States and foundry representatives established a workgroup that provides an open forum for discussion, identifies relevant environmental issues facing foundries and develops educational assistance programs.

Through education and compliance assistance, the program aims to improve communication between the industry and the regulatory agencies and increase voluntary compliance with the regulations. The program provides foundries with information to fix problems before active enforcement occurs. For example, in Oklahoma where the initiative has recently been completed, a six month correction period was offered. Workshops and seminars were held in each state and individual compliance assistance and site visits are being offered. Contact: Joel Dougherty, Ph.D., (214) 665-2281.

VIII.A.2. State Activities

Oklahoma

The Oklahoma Department of Environmental Quality (DEQ) Customer Assistance Program recently completed its Foundry Initiative with EPA Region VI (See above). After Region 6 made plans to inspect 12 facilities in Oklahoma, the Oklahoma (DEQ) suggested an alternate strategy. A multi-media workshop was held in April 1995 that focused on pollution issues facing the foundry industry. From that workshop, an entire state-wide compliance achievement program was developed for metal casting facilities.

The Program consisted of the following trade-offs between industry and the regulators.

- 1) The industry would perform an environmental self-audit and fix any problems identified.
- 2) The DEQ and the EPA would allow a six month "correction period."
- 3) During the correction period any regularly scheduled annual inspections were canceled. This allowed the facility to focus on identifying and correcting areas of non-compliance.
- 4) At the end of the "correction period" there would be a return to normally scheduled inspections.

Of the 45 qualifying facilities in Oklahoma, 23 participated in the program. Each of the 23 facilities performed a self-audit that covered air quality, water quality, and waste management issues. Each facility also completed the program, which included workshops, self-audits, site visits, and "free" inspections. The types of compliance issues that were corrected as a result of the program were:

- 1) state minor air permits,
- 2) solid waste disposal approvals,
- 3) storm water pollution prevention plans,
- 4) SARA Title III reporting, and
- 5) air pollution controls.

An important outcome was the new relationship between the foundries and the agency. This new relationship was based on information sharing for the common goal of compliance. The participating foundries were able to obtain permits and disposal approvals without penalty. Several facilities continue to work with the DEQ to solve more complex compliance issues, such as on-site land disposal of foundry sand. Contact: Dave Dillon, Customer Assistance Program, Oklahoma DEQ, (405) 271-1400.

University of Wisconsin - Milwaukee Center for By-Product Utilization

At the University of Wisconsin - Milwaukee Center for By-Product Utilization researchers are examining the feasibility of using spent foundry sand and slag as feed for concrete manufacturing. The center is testing the compression strengths of concrete mixed with 25 percent and 35 percent (by weight) of different types of used foundry sand. Tests are also being carried out substituting foundry sand in asphaltic concrete. Many of the tests have shown that structural grade concrete and asphaltic concrete can be produced successfully and economically using waste foundry sand.

VIII.B. EPA Voluntary Programs*33/50 Program*

The 33/50 Program is a groundbreaking program that has focused on reducing pollution from seventeen high-priority chemicals through voluntary partnerships with industry. The program's name stems from its goals: a 33% reduction in toxic releases by 1992, and a 50% reduction by 1995, against a baseline of 1.5 billion pounds of releases and transfers in 1988. The results have been impressive: 1,300 companies have joined the 33/50 Program (representing over 6,000 facilities) and have reached the national targets a year ahead of schedule. The 33% goal was reached in 1991, and the 50% goal -- a reduction of 745 million pounds of toxic wastes -- was reached in 1994. The 33/50 Program can provide case studies on many of the corporate accomplishments in reducing waste (Contact 33/50 Program Director David Sarokin -- 202-260-6396).

Table 19 lists those companies participating in the 33/50 program that reported four-digit SIC codes within 332 and 336 to TRI. Some of the companies shown also listed facilities that are not producing metal castings. The number of facilities within each company that are participating in the 33/50 program and that report metal casting SIC codes is shown. Where available and quantifiable against 1988 releases and transfers, each company's 33/50 goals for 1995 and the actual total releases and transfers and percent reduction between 1988 and 1994 are presented.

Fourteen of the seventeen target chemicals were reported to TRI by metal casting facilities in 1994. Of all TRI chemicals released and transferred by the metal casting industry, nickel and nickel compounds, and chromium and chromium compounds (both 33/50 target chemicals), were released and transferred second and third most frequently (behind copper), and were in the top ten largest volume released and transferred. Other frequently reported 33/50 target chemicals were lead and lead compounds, xylenes and toluene.

Table 20 shows that 55 companies comprised of 129 facilities reporting SIC 332 and 336 are participating in the 33/50 program. For those companies shown with more than one metal casting facility, all facilities may not be participating in 33/50. The 33/50 goals shown for companies with multiple metal casting facilities, however, are company-wide, potentially aggregating more than one facility and facilities not carrying out metal casting operations. In addition to company-wide goals, individual facilities within a company may have their own 33/50 goals or may be specifically listed as not participating in the 33/50 program. Since the actual percent reductions shown in the last column apply to all of the companies' metal casting facilities and only metal casting facilities, direct comparisons to those company goals incorporating non-metal casting facilities or excluding certain facilities may not be possible.

For information on specific facilities participating in 33/50, contact David Sarokin (202-260-6907) at the 33/50 Program Office.

Table 20: Metal Casting Industry Participation in the 33/50 Program

Parent Company (Headquarters Location)	Company- Owned Metal Casting Facilities Reporting 33/50 Chemicals	Company- Wide % Reduction Goal¹ (1988 to 1995)	1988 TRI Releases and Transfers of 33/50 Chemicals (pounds)²	1994 TRI Releases and Transfers of 33/50 Chemicals (pounds)²	Actual % Reduction for Metal Casting Facilities (1988-1994)
A B & I Incorporated Oakland, CA	1	98	455,570	345,419	24
Allied-Signal Inc Morristown, NJ	1	50	500	0	100
American Cast Iron Pipe Co Birmingham, AL	3	25	761,209	188,769	75
Ampco Metal Mfg. Inc. Milwaukee, WI	2	*	2,500	12,552	-402
Amsted Industries Incorporated - Chicago, IL	9	66	1,066,730	2,174,300	-104
Armco Inc - Pittsburgh, PA	3	4	74,810	16,480	78
Auburn Foundry Inc Auburn, IN	1	99	592,150	465	100
Bloomfield Foundry Inc Bloomfield, IA	1	***	500	520	-4
Burnham Corporation Lancaster, PA	1	95	99,149	700	99
Cast-Fab Technologies Inc Cincinnati, OH	1	54	24,196	50	100
Caterpillar Inc - Peoria, IL	2	60	24,650	265,815	-978
Chrysler Corporation Auburn Hills, MI	2	80	37,082	18,281	51
Columbia Steel Casting Co Portland, OR	1	*	0	16,801	-
Cooper Industries Inc Houston, TX	4	75	100,873	224,830	-123
Dalton Foundries Inc Warsaw, IN	2	75	594,000	106,996	82
Dana Corporation Toledo, OH	1	**	0	8,860	-
Deere & Company Moline, IL	1	*	161,942	8,337	95
Duriron Company Inc Dayton, OH	1	36	49,725	0	100
Electric Steel Castings Co Indianapolis, IN	1	***	0	0	-

Metal Casting Industry
Activities and Initiatives

Parent Company (Headquarters Location)	Company- Owned Metal Casting Facilities Reporting 33/50 Chemicals	Company- Wide % Reduction Goal ¹ (1988 to 1995)	1988 TRI Releases and Transfers of 33/50 Chemicals (pounds) ²	1994 TRI Releases and Transfers of 33/50 Chemicals (pounds) ²	Actual % Reduction for Metal Casting Facilities (1988-1994)
Emerson Electric Co Saint Louis, MO	2	50	0	0	-
Federal-mogul Corporation Southfield, MI	1	50	0	3,455	-
Ford Motor Company Dearborn, MI	1	15	94,478	96,803	-2
Funk Finecast Inc Columbus, OH	1	*	14,290	596	96
General Electric Company Fairfield, CT	1	50	0	195	-
General Motors Corporation Detroit, MI	3	*	676,800	387,813	43
Hartzell Manufacturing Inc Saint Paul, MN	1	85	250	0	100
Hitchiner Manufacturing Co Milford, NH	4	50	91,930	699	99
Hubbell Incorporated Orange, CT	1	***	23,641	0	100
Interlake Corporation Lisle, IL	1	37	8,000	0	100
Jefferson City Mfg Co Inc Jefferson City, MO	1	**	29,500	0	100
Naco Inc - Lisle, IL	7	***	250,920	102,532	59
Navistar Intl Transportation Co - Chicago, IL	2	*	40,500	0	100
Newell Co - Freeport, IL	16	23	1,091,853	149,630	86
Ngk Metals Corp. Temple, PA	1	99	280	2,800	-900
Northern Precision Casting Co - Lake Geneva, WI	1	99	18,583	96	99
Pac Foundries Port Hueneme, CA	1	75	16,950	0	100
Pacific Alloy Castings South Gate, CA	1	**	1,500	2,659	-77
Pechiney Corporation Greenwich, CT	4	***	266,950	24,099	91
PHB Inc - Fairview, PA	1	100	22,292	0	100
Precision Castparts Corp Portland, OR	10	29	584,861	197,377	66
Premark International Inc Deerfield, IL	1	***	0	530	-

Parent Company (Headquarters Location)	Company- Owned Metal Casting Facilities Reporting 33/50 Chemicals	Company- Wide % Reduction Goal ¹ (1988 to 1995)	1988 TRI Releases and Transfers of 33/50 Chemicals (pounds) ²	1994 TRI Releases and Transfers of 33/50 Chemicals (pounds) ²	Actual % Reduction for Metal Casting Facilities (1988-1994)
Progress Casting Group Inc Minneapolis, MN	1	95	17,412	0	100
Rexcorp U S Inc (Del) Sandwich, IL	1	***	0	274	-
SKF USA Inc King of Prussia, PA	1	***	67,662	0	100
Slyman Industries Inc Medina, OH	1	100	3,858	18,912	-390
Smith Everett Investment Co - Milwaukee, WI	1	89	2,907	1,035	64
Spuncast Inc - Watertown, WI	1	***	0	4	-
SPX Corporation Muskegon, MI	1	2	0	0	-
Sure Cast Inc - Burnet , TX	1	*	0	510	-
Tenneco Inc - Houston , TX	2	8	370,489	0	100
Thyssen Holding Corporation - Troy, MI	3	11	262,300	395,814	-51
Walter Industries Inc Tampa, FL	11	***	1,433,194	536,132	63
Watts Industries Inc North Andover, MA	3	15	97,620	12,070	88
York Mold Inc. Manchester, PA	1	*	500	500	0
Young Corporation Seattle, WA	1	***	0	0	-
TOTAL	129	--	9,535,106	5,323,710	44

Source: U.S. EPA 33/50 Program Office, 1996.

¹ Company-Wide Reduction Goals aggregate all company-owned facilities which may include facilities not producing metal castings.

² Releases and Transfers are from metal casting facilities only.

* = Reduction goal not quantifiable against 1988 TRI data.

** = Use reduction goal only.

*** = No numeric reduction goal.

Environmental Leadership Program

The Environmental Leadership Program (ELP) is a national initiative developed by EPA that focuses on improving environmental performance, encouraging voluntary compliance, and building working relationships with stakeholders. EPA initiated a one year pilot program in 1995 by selecting 12 projects at industrial facilities and federal installations which would demonstrate the principles of the ELP program. These principles include: environmental management systems, multimedia compliance assurance, third-party verification of compliance, public measures of accountability, pollution prevention, community involvement, and mentor programs. In return for participating, pilot participants received public recognition and were given a period of time to correct any violations discovered during these experimental projects.

EPA is making plans to launch its full-scale Environmental Leadership Program in 1997. The full-scale program will be facility-based with a 6-year participation cycle. Facilities that meet certain requirements will be eligible to participate, such as having a community outreach/employee involvement programs and an environmental management system (EMS) in place for 2 years. (Contact: <http://es.inel.gov/elp> or Debby Thomas, ELP Deputy Director, at 202-564-5041)

Project XL

Project XL was initiated in March 1995 as a part of President Clinton's *Reinventing Environmental Regulation* initiative. The projects seek to achieve cost effective environmental benefits by providing participants regulatory flexibility on the condition that they produce greater environmental benefits. EPA and program participants will negotiate and sign a Final Project Agreement, detailing specific environmental objectives that the regulated entity shall satisfy. EPA will provide regulatory flexibility as an incentive for the participants' superior environmental performance. Participants are encouraged to seek stakeholder support from local governments, businesses, and environmental groups. EPA hopes to implement fifty pilot projects in four categories, including industrial facilities, communities, and government facilities regulated by EPA. Applications will be accepted on a rolling basis. For additional information regarding XL projects, including application procedures and criteria, see the May 23, 1995 Federal Register Notice. (Contact: Fax-on-Demand Hotline 202-260-8590, Web: <http://www.epa.gov/ProjectXL>, or Christopher Knopes at EPA's Office of Policy, Planning and Evaluation 202-260-9298)

Climate Wise Program

Climate Wise is helping US industries turn energy efficiency and pollution prevention into a corporate asset. Supported by the technical assistance, financing information and public recognition that Climate Wise offers, participating companies are developing and launching comprehensive industrial energy efficiency and pollution prevention action plans that save money and protect the environment. The nearly 300 Climate Wise companies expect to save more than \$300 million and reduce greenhouse gas emissions by 18 million metric tons of carbon dioxide equivalent by the year 2000. Some of the actions companies are undertaking to achieve these results include: process improvements, boiler and steam system optimization, air compressor system improvements, fuel switching, and waste heat recovery measures including cogeneration. Created as part of the President's Climate Change Action Plan, Climate Wise is jointly operated by the Department of Energy and EPA. Under the Plan many other programs were also launched or upgraded including Green Lights, WasteWi\$e and DoE's Motor Challenge Program. Climate Wise provides an umbrella for these programs which encourage company participation by providing information on the range of partnership opportunities available. (Contact: Pamela Herman, EPA, 202-260-4407 or Jan Vernet, DoE, 202-586-4755)

Energy Star Buildings Program

EPA's ENERGY STAR Buildings Program is a voluntary, profit-based program designed to improve the energy-efficiency in commercial and industrial buildings. Expanding the successful Green Lights Program, ENERGY STAR Buildings was launched in 1995. This program relies on a 5-stage strategy designed to maximize energy savings thereby lowering energy bills, improving occupant comfort, and preventing pollution -- all at the same time. If implemented in every commercial and industrial building in the United States, ENERGY STAR Buildings could cut the nation's energy bill by up to \$25 billion and prevent up to 35% of carbon dioxide emissions. (This is equivalent to taking 60 million cars off the road). ENERGY STAR Buildings participants include corporations; small and medium sized businesses; local, federal and state governments; non-profit groups; schools; universities; and health care facilities. EPA provides technical and non-technical support including software, workshops, manuals, communication tools, and an information hotline. EPA's Office of Air and Radiation manages the operation of the ENERGY STAR Buildings Program. (Contact: Green Light/Energy Star Hotline at 1-888-STAR-YES or Maria Tikoff Vargas, EPA Program Director at 202-233-9178 or visit the ENERGY STAR Buildings Program website at <http://www.epa.gov/appdstar/buildings/>)

Green Lights Program

EPA's Green Lights program was initiated in 1991 and has the goal of

preventing pollution by encouraging U.S. institutions to use energy-efficient lighting technologies. The program saves money for businesses and organizations and creates a cleaner environment by reducing pollutants released into the atmosphere. The program has over 2,345 participants which include major corporations, small and medium sized businesses, federal, state and local governments, non-profit groups, schools, universities, and health care facilities. Each participant is required to survey their facilities and upgrade lighting wherever it is profitable. As of March 1997, participants had lowered their electric bills by \$289 million annually. EPA provides technical assistance to the participants through a decision support software package, workshops and manuals, and an information hotline. EPA's Office of Air and Radiation is responsible for operating the Green Lights Program. (Contact: Green Light/Energy Star Hotline at 1-888-STARYES or Maria Tikoff Vargar, EPA Program Director, at 202-233-9178)

WasteWi\$e Program

The WasteWi\$e Program was started in 1994 by EPA's Office of Solid Waste and Emergency Response. The program is aimed at reducing municipal solid wastes by promoting waste prevention, recycling collection and the manufacturing and purchase of recycled products. As of 1997, the program had about 500 companies as members, one third of whom are Fortune 1000 corporations. Members agree to identify and implement actions to reduce their solid wastes setting waste reduction goals and providing EPA with yearly progress reports. To member companies, EPA, in turn, provides technical assistance, publications, networking opportunities, and national and regional recognition. (Contact: WasteWi\$e Hotline at 1-800-372-9473 or Joanne Oxley, EPA Program Manager, 703-308-0199)

NICE³

The U.S. Department of Energy is administering a grant program called The National Industrial Competitiveness through Energy, Environment, and Economics (NICE³). By providing grants of up to 45 percent of the total project cost, the program encourages industry to reduce industrial waste at its source and become more energy-efficient and cost-competitive through waste minimization efforts. Grants are used by industry to design, test, and demonstrate new processes and/or equipment with the potential to reduce pollution and increase energy efficiency. The program is open to all industries; however, priority is given to proposals from participants in the forest products, chemicals, petroleum refining, steel, aluminum, metal casting and glass manufacturing sectors. (Contact: <http://www.oit.doe.gov/access/nice3>, Chris Sifri, DOE, 303-275-4723 or Eric Hass, DOE, 303-275-4728)

Design for the Environment (DfE)

DfE is working with several industries to identify cost-effective pollution prevention strategies that reduce risks to workers and the environment. DfE helps businesses compare and evaluate the performance, cost, pollution prevention benefits, and human health and environmental risks associated with existing and alternative technologies. The goal of these projects is to encourage businesses to consider and use cleaner products, processes, and technologies. For more information about the DfE Program, call (202) 260-1678. To obtain copies of DfE materials or for general information about DfE, contact EPA's Pollution Prevention Information Clearinghouse at (202) 260-1023 or visit the DfE Website at <http://es.inel.gov/dfe>.

VIII.C. Trade Association/Industry Sponsored Activity

VIII.C.1. Industry Research Programs

American Metalcasting Consortium (AMC)

The American Metalcasting Consortium (AMC) is a group of six organizations from the metalcasting industry that have joined together to ally the thousands of small and medium sized metalcasters within the market in an effort to re-establish American viability in the metalcasting industry. AMC aims to energize critical facets of the industry which stimulate lead time and cost reductions, quality, and market share/growth. These goals are being implemented through efforts focused on projects in the areas of 1) applied research and development, 2) education, training, and technology transfer, 3) small business, and 4) casting applications development. Many of the projects will result in positive environmental impacts by improving the industry's overall energy efficiency and reducing the quantity of wastes and off-spec castings. The AMC organizations are: The American Foundrymen's Society (AFS); Non-Ferrous Founders' Society (NFFS); North American Die Casting Association (NADCA); and the Steel Founders' Society of America (SFSA).

Cast Metals Coalition (CMC)

In 1995, Chief Executive Officers and Presidents from the foundry, diecasting, and foundry supply industries developed goals for the future of the industry in *Beyond 2000: A Vision for the American Metalcasting Industry*. Representatives from the American Foundrymen's Society, the Steel Founders' Society of America, and the North American Die Casters Association formed the Cast Metals Coalition (CMC). The CMC is working towards developing a technology roadmap for pursuing and achieving these goals. CMC is working with industry and research institutions, including universities and national laboratories to develop this roadmap.

Pennsylvania Foundry Consortia

A consortia of Pennsylvania foundries, the Pennsylvania Foundrymen's Association and Penn State University have been working cooperatively since 1985 on issues associated with solid waste disposal, sand reclamation, and beneficial use of foundry residuals. This group is addressing the impediments to beneficial use of foundry residuals on a comprehensive national level. The goals of the research are to maximize the beneficial reuse of environmentally safe foundry residuals and to streamline the path for their acceptability by other industries. Specific tasks carried out involve establishing a database of technical and environmental information to support reuse applications, developing and administering a comprehensive survey of potential aggregate users, and performing physical and environmental testing to demonstrate the applicability of residual wastes for reuse applications. The program receives funding from a U.S. EPA grant.

VIII.C.2. Trade Associations

American Foundrymen's Society, Inc. (AFS) 505 State Street Des Plaines, IL 60016-8399 Phone: (800) 537-4237 Fax: (847) 824-7848	Members: 12,800 Staff: 60 Contact: Gary Mosher, Vice President, Environmental Health and Safety
--	---

The American Foundrymen's Society (AFS) is the primary trade association for the foundry industry. Founded in 1896, the Society has student and local groups throughout the U.S. and internationally. AFS is the technical, trade, and management association of foundrymen, pattern makers, technologists, and educators. The society sponsors foundry training courses through the Cast Metals Institute on all subjects pertaining to the casting industry and sponsors numerous regional and local conferences and meetings. AFS maintains an extensive Technical Information Center, conducts research programs, compiles statistics, and provides marketing information, environmental services, and testing. The monthly trade magazine, *Modern Casting*, covers current technology practices and other factors affecting the production and marketing of metal castings.

North American Die Casting Association (NADCA) 9701 W. Higgins Rd., Ste. 880 Rosemont, IL 60018 Phone: 847-292-3600 Fax: 847-292-3620	Members: 3,200 Staff: 17 Contact: Dan Twarog
--	--

The North American Die Casting Association (NADCA) was founded in 1989 and is made up of producers of die castings and suppliers to industry, product and die designers, metallurgists, and students. There are regional and local groups across the U.S. NADCA develops product standards; compiles trade statistics on metal consumption trends; conducts promotional activities; and provides information on chemistry, mechanics, engineering, and other arts and sciences related to die casting. The association also maintains a library and provides training materials and short, intensive courses in die casting. A trade magazine, *Die Casting Engineer*, is published periodically and contains information on new products and literature, chapter news, and a calendar of events.

Non-Ferrous Founders' Society
455 State St., Suite 100
Des Plaines, IL 60016
Phone: 847-299-0950
Fax: 847-299-3598

Members: 185
Staff: 2
Contact: Jim Mallory or Mark
Remlinger, Chair of
Environment Committee

The Non-Ferrous Founders' Society (NFFS) is comprised of manufacturers of brass, bronze, aluminum, and other nonferrous castings. Founded in 1943, NFFS conducts research programs and compiles statistics related to the nonferrous castings industry. The Society has committees related to: export government relations; insurance; local management group; management conferences; planning; quality; and technical research. NFFS publishes *The Crucible* bimonthly. This trade magazine contains articles relevant to the day-to-day management of aluminum, brass, bronze, and other nonferrous foundries. NFFS also publishes a biennial *Directory of Nonferrous Foundries* listing member and nonmember foundries producing primarily aluminum, brass, and bronze castings.

Steel Founders' Society of America
(SFSA)
Cast Metals Fed. Bldg.
455 State St.
Des Plaines, IL 60016
Phone: 847-299-9160
Fax: 847-299-3105

Members: 75
Staff: 6
Contact: Raymond Monroe

The Steel Founders Society of America (SFSA) is comprised of manufacturers of steel castings. Founded in 1902, the Society conducts research programs and compiles statistics related to the steel casting industry. SFSA periodically publishes *CASTEEL* which contains special articles on specifications and technical aspects of steel castings. SFSA also publishes a biennial *Directory of Steel Foundries* listing steel foundries in the U.S., Canada, and Mexico. Committees include Marketing, Specifications, and Technical Research.

Investment Casting Institute
8350 N. Central Expressway
Suite M 1110
Dallas, TX 75206
Phone: 214-368-8896
Fax: 214-368-8852

Members: 275
Staff: 5
Contact: Henry Bidwell

The Investment Casting Institute is an international trade association comprised of manufacturers of precision castings for industrial use made by the investment (or lost wax) process and suppliers to such manufacturers. The Institute provides training

courses and other specialized education programs and publishes the monthly newsletter *Incast*.

Casting Industry Suppliers Association
(CISA)
455 State St., Suite 104
Des Plaines, IL 60016
Phone: 708-824-7878
Fax: 708-824-7908

Members: 66
Staff: 1
Contact: Darla Boudjenah

The Casting Industry Suppliers Association (CISA) was founded in 1986 and represents manufacturers of foundry equipment and supplies such as molding machinery, dust control equipment and systems, blast cleaning machines, tumbling equipment, and related products. CISA also aims to foster better trade practices and serve as an industry representative before the government and the public. The Association also compiles industry statistics and disseminates reports of progress in new processes and methods in foundry operation.

The Ferroalloys Association (TFA)
900 2nd St. NE, Suite 201
Washington, DC 20002
Phone: 202-842-0292
Fax: 202-842-4840

Members: 21
Staff: 3
Contact: Edward Kinghorn Jr.

The purpose of The Ferroalloys Association's (TFA) is to promote the general welfare of the producers of chromium, manganese, silicon, vanadium ferroalloys and related basic alloys/metals in the United States and to engage in all lawful activities to that end. Founded in 1971, TFA consistently provides the ferroalloy industry a means to accomplish tasks through a common bond of business interests.

The ferroalloy industry produces high strength metals created by submerged electric arc smelting, induction melting, alumino/silicothermic reduction processes, and vacuum reduction furnaces, as well as by electrolytic processes. More than 50 different alloys and metals in hundreds of compositions and sizes are produced by the ferroalloy industry for use in the manufacturing of stainless steel, iron, and aluminum. The industry also produces vital materials used in the production of chemicals, semi-conductors, solar cells, coatings, and catalysts.

IX. CONTACTS/ACKNOWLEDGMENTS/RESOURCE MATERIALS

For further information on selected topics within the metal casting industry a list of contacts and publications are provided below.

Contacts⁵

Name	Organization	Telephone	Subject
Jane Engert	EPA/OECA (Office of Enforcement and Compliance Assurance)	202-564-5021	Compliance assistance
James Maysilles	EPA/OAR (Office of Air and Radiation)	919-541-3265	Regulatory requirements (air)
Mary Cunningham	EPA/OSW (Office of Solid Waste)	703-308-8453	Regulatory requirements (RCRA)
Larry Gonzales	EPA/OSW (Office of Solid Waste)	703-308-8468	Regulatory requirements (RCRA) and waste sand treatment
George Jett	EPA/OW (Office of Water), Office of Science and Technology	202-260-7151	Regulatory requirements (water)
Doug Kaempf	DOE (Department of Energy)	202-586-5264	Energy efficiency and technology trends
Bill Walden	Casting Emissions Reduction Program (McClellan AFB, CA)	916-643-1090	Air emissions and casting technologies
Joel Dougherty	EPA/Region VI	214-665-8323	Regulatory requirements pollution prevention
David Byro	EPA/Region III	215-566-5563	Pollution prevention
Dave Dillon	Oklahoma Department of Environmental Quality	405-271-1400	Industrial processes and pollution prevention
Gary Mosher	American Foundrymen's Society Vice President Environmental Health and Safety	800-537-4237	Environment and pollution prevention
Ted Kinghorn Megan Medley	Non-Ferrous Founders' Society	202-842-0219	Regulatory issues
Dan Twarog Tricia Margel	North American Die Casting Association	847-292-3600	Regulatory issues and pollution prevention
Raymond Monroe	Steel Founders Society of America	847-299-9160	Regulatory issues
Bob Voigt	Pennsylvania State University	814-863-7290	Industrial processes

⁵ Many of the contacts listed above have provided valuable information and comments during the development of this document. EPA appreciates this support and acknowledges that the individuals listed do not necessarily endorse all statements made within this notebook.

Section II: Introduction to the Metal Casting Industry

LaRue, James P., Ed.D., *Basic Metal Casting*, American Foundrymen's Society, Des Plaines, IL, 1989.

U.S. Industrial Outlook 1994, U.S. Department of Commerce, International Trade Administration, 1995.

1992 Census of Manufacturers Industry Series: Ferrous and Nonferrous Foundries, Department of Commerce, Bureau of the Census, 1996.

Trends Effecting [sic] R&D in the Metalcasting Industry, U.S. Department of Energy, Office of Industrial Technologies, Washington, D.C., March 1996.

Kirgin, Kenneth H., *1990s Provide Stability for Ferrous Foundries, Part 1*, Modern Casting, American Foundrymen's Society, Des Plaines, IL, vol. 86 no. 8, August 1995. pp35-37.

Beyond 2000: A Vision for the American Metalcasting Industry, Cast Metals Coalition, September, 1995.

Walden, William C., *Casting Emissions Reduction Program (CERP) Primer*, U.S. Department of Defense, September, 1995.

Rost, John E., *Rebound in Casting Markets Bodes Well for U.S. Foundries*, Modern Casting, American Foundrymen's Society, Des Plaines, IL, vol. 82 no. 1, January 1992. pp29-31.

Loper, Carl R. Jr., *Foundry Practice and Equipment*, Mark's Standard Handbook for Mechanical Engineers, 8th ed., McGraw Hill, 1985. pp. 13-2 - 13-9.

Kunsman, C.D., and Carlson, C.C., *NonFerrous Metals*, Mark's Standard Handbook for Mechanical Engineers, 8th ed., McGraw Hill, 1985. pp. 6-59 - 6-89.

Kirgin, Kenneth H., *Slowing Economy Lowers Casting Demand*, Modern Casting, American Foundrymen's Society, Des Plaines, IL, vol. 85 no. 6, June 1994. p70.

Kirgin, Kenneth H., *Forecast Remains Bullish for '95*, Modern Casting, American Foundrymen's Society, Des Plaines, IL, vol. 85 no. 3, March 1995. p51.

Kirgin, Kenneth H., *Continued Slowdown in '96 Could Lower Casting Shipments 7%*, Modern Casting, American Foundrymen's Society, Des Plaines, IL, vol. 85 no. 9, September 1995. p54.

Section III: Industrial Process Description

LaRue, James P., Ed.D., *Basic Metal Casting*, American Foundrymen's Society, Des Plaines, IL, 1981.

Metal Casting and Molding Processes, ed. Kotzin, Ezra L., American Foundrymen's Society, Des Plaines, IL, 1981.

Kotzin, Ezra L., *Steel Foundries: Air Pollution Engineering Manual*, ed. Buonicore, Anthony J. and Davis, Wayne T., Air and Waste Management Association, Van Nostrand Reinhold, New York, 1992. pp. 733-738.

Scott, Bruce, *Sulfur: Air Pollution Engineering Manual*, ed. Buonicore, Anthony J. and Davis, Wayne T., Air and Waste Management Association, Van Nostrand Reinhold, New York, 1992. pp. 476-477.

Licht, Charles A., *Secondary Brass and Bronze Melting Processes: Air Pollution Engineering Manual*, ed. Buonicore, Anthony J. and Davis, Wayne T., Air and Waste Management Association, Van Nostrand Reinhold, New York, 1992. pp. 733-738.

Leidel, Dieter S., *Pollution Prevention and Foundries*, from Industrial Pollution Prevention Handbook, ed. Freeman, Harry M., McGraw-Hill, Inc., New York, 1995. pp. 667-684.

Profile of the Fabricated Metal Products Industry, Sector Notebook Project, U.S. EPA Office of Compliance, Washington D.C., September 1995. (EPA-310-R-95-007)

Pretreatment of Industrial Wastes, Manual of Practice No. FD-3, Water Environment Federation, Alexandria, Virginia, 1994.

American Foundrymen's Society Air Quality Committee, *Iron Foundries: Air Pollution Engineering Manual*, ed. Buonicore, Anthony J. and Davis, Wayne T., Air and Waste Management Association, Van Nostrand Reinhold, New York, 1992. pp. 719-723.

Summary of Factors Affecting Compliance by Ferrous Foundries, Volume I - Text, Final Report, U.S. EPA, Office of General Enforcement, Washington D.C., January 1981. (EPA-340/1-80-020)

Allsop, D. F., and Kennedy, D., *Pressure Diecasting*, Pergamon Press, Oxford, 1983.

Kaye, Alan, and Street, Arthur, *Die Casting Metallurgy*, Butterworth Scientific, London, 1982.

Street, Arthur, *The Diecasting Book*, Portcullis Press Ltd., Surrey, U.K., 1977.

Form R Reporting of Binder Chemicals Used in Foundries, American Foundrymen's Society, Des Plaines, IL, and Casting Industry Suppliers Association, Worthington, OH, 1992.

Competitive Assessment of the U.S. Foundry Industry, U.S. International Trade Commission, Washington, D.C., 1984. (USITC Publication 1582)

Twarog, Daniel L., and University of Alabama, *Waste Management Study of Foundries Major Waste Streams: Phase I*, Hazardous Waste Research and Information Center, Champaign, IL, January 1993. (HWRIC TR-011)

McKinley, Marvin D., et al., *Waste Management Study of Foundries Major Waste Streams: Phase II*, Hazardous Waste Research and Information Center, Champaign, IL, April 1994. (HWRIC TR-016)

AP-42 Sections 7.13: Steel Foundries and 7.10: Gray Iron Foundries, U.S. EPA Office of Air and Radiation, October 1986.

Section IV: Chemical Release and Transfer Profile

1994 Toxics Release Inventory Public Data Release, U.S. EPA Office of Pollution Prevention and Toxics, June 1996. (EPA 745-R-96-002)

Section V: Pollution Prevention Opportunities

Guides to Pollution Prevention, The Metal Casting and Heat Treating Industry, U.S. EPA, Office of Research and Development, Cincinnati, OH, September 1992. (EPA/625/R-92/009)

Foundry Sand Beneficial Reuse Manual, Special Report, ed. Thomas, Susan P., American Foundrymen's Society, Des Plaines, IL, 1996.

Philbin, Matthew L., *Sand Reclamation Equipment Users Answer the Questions*, Modern Casting, American Foundrymen's Society, Des Plaines, IL, vol. 86 no. 8, August 1996. pp22-26.

Leidel, Dieter S., *Pollution Prevention and Foundries*, from Industrial Pollution Prevention Handbook, ed. Freeman, Harry M., McGraw-Hill, Inc., New York, 1995. pp. 667-684.

Pollution Prevention Practices for the Die Casting Industry, North American Die Casting Association, Rosemont, IL, 1996.

Personal Correspondence with Ms. Suzanne Simoni, Pennsylvania Department of Environmental Protection, Office of Pollution Prevention and Compliance Assistance, Conshohocken, PA, November 1996.

U.S. EPA Enviro\$en\$e website, http://www.portfolio/epa/environet/ncpd/auscase_studies/mason.html, 1996.

Twarog, Daniel L., and University of Alabama, *Waste Management Study of Foundries Major Waste Streams: Phase I*, Hazardous Waste Research and Information Center, Champaign, IL, January 1993. (HWRIC TR-011)

McKinley, Marvin D., et al., *Waste Management Study of Foundries Major Waste Streams: Phase II*, Hazardous Waste Research and Information Center, Champaign, IL, April 1994. (HWRIC TR-016)

Archer, Hugh V., et al., *Foundry Calculates the Value of Pollution Prevention*, Water Environment and Technology, vol. 6, no. 6, June, 1994.

Estes, John M., *Energy Cutting Can Give Foundries Real Savings*, Modern Casting, American Foundrymen's Society, Des Plaines, IL, vol. 84, no. 11, November 1994.

Binczewski, George J., *Aluminum Casting and Energy Conservation*, Light Metal Age, vol. 51, no. 11-12, December 1993.

Profile of the Iron and Steel Industry, U.S. EPA Office of Compliance, Washington D.C., 1995.

Section VI: Summary of Applicable Federal Statutes and Regulations

Transactions of the American Foundrymen's Society, Proceedings of the Ninety-Ninth Annual Meeting, April 23-26, 1995, American Foundrymen's Society, Des Plaines, IL, vol.103.

Lessiter, Michael J., *Foundries Prepare for Clean Air Act's Title V Showdown*, Modern Casting, American Foundrymen's Society, Des Plaines, IL, November 1994. pp. 58-59.

Title V Air Operating Permits: What They Mean for Foundries, Modern Casting, American Foundrymen's Society, Des Plaines, IL, vol. 85, no. 1, February 1995. pp. 52-53.

Kwan, Quon Y., and Kaempf, Douglas E., *Environmental Compliance in Metalcasting, Part 1*, Foundry Management and Technology, pg. 42, October 1995.

Kwan, Quon Y., and CEMF, Douglas E., *Environmental Compliance in Metalcasting, Part 2*, Foundry Management and Technology, pg. 39, November 1995.

Breen, Barry, and Campbell-Mohn, Celia, *Sustainable Environmental Law, Chapter 16: Metals*, Environmental Law Institute, West Publishing Co., St. Paul, MN, 1993.

Section VIII: Compliance Activities and Initiatives

American Metalcasting Consortium, <http://www.scra.org/amc/>, 1996.

U.S. EPA Enviro\$en\$e website, http://www.portfolio/epa/environet/ncpd/auscase_studies/mason.html, 1996.

Beyond 2000: A Vision for the American Metalcasting Industry, Cast Metals Coalition, September, 1995.

Personal Correspondence with Mr. David Byro, U.S. EPA, Region III, Philadelphia, PA, June 1996.

Personal Correspondence with Joel Dougherty, Ph.D., U.S. EPA, Region 6, Hazardous Waste Enforcement Branch, Dallas, TX, October 1996.

Personal Correspondence with Mr. Bill Walden, U.S. Department of Defense, McClellan AFB, CA, June 1996.

Personal Correspondence with Ms. Kathy Martin, Oklahoma Department of Environmental Quality, Oklahoma City, OK, September 1996.

Personal Correspondence with Ms. Suzanne Simoni, Pennsylvania Department of Environmental Protection, Office of Pollution Prevention and Compliance Assistance, Conshohocken, PA, November 1996.

Personal Correspondence with Mr. Douglas Kaempf, U.S. Department of Energy, Industries of the Future, Washington, D.C., July 1996.