

Part II

# Projects



## Applied Mathematics: Collaborative Research

### Solidification Modeling

*Geoffrey McFadden*

*Katherine Gurski*

*J. Guyer (NIST MSEL)*

*William Boettinger (NIST MSEL)*

*Sam Coriell (NIST MSEL)*

*D. Josell (NIST MSEL)*

*James Warren (NIST MSEL)*

*B. Andrew (U. Alabama)*

*M. Miksis (Northwestern U.)*

*Bruce Murray (SUNY Binghamton)*

MCS D is collaborating with the NIST Materials Science and Engineering Laboratory (MSEL) on a number of projects involving solidification and other types of phase transitions. These projects seek to understand how materials processing techniques affect the physical properties of the resulting products. The modeling problems typically involve nonlinear free boundary problems in which the shape and dynamics of the interfaces that separate the material phases need to be described in detail. For the past several years the research has been supported by grants from the NASA Microgravity Research Division, and has been conducted in collaboration with colleagues from Carnegie Mellon University, George Mason University, Northwestern University, the State University of New York at Binghamton, and the University of Alabama in Birmingham.

In collaboration with J. Guyer, W. Boettinger, and J. Warren (MSEL), G. McFadden developed a phase-field model of electrodeposition, in which an electric field is used to control the plating of conducting electrolyte onto an electrode. This work extends previous modeling results for binary alloys by considering four-component systems, and including the electric field effects on the transport of solute. The phase-field method is a technique to facilitate treatment of the interface between the electrolyte and electrode where material is depositing. Both dynamical and steady state codes have been developed to study the effects of electrocapillarity and solute adsorption at the electrode. This work is in support of NIST experimental studies of electrodeposition in high-aspect-ratio trenches (see figure), where the goal is to fill the trench with deposited material before the trench pinches off, leaving behind a void. In related work, G. McFadden collaborated with Dan Josell and Sam Coriell (MSEL) in performing a linear stability analysis for a model of electrodeposition that is intended to help understand the observed length scales in surface roughness during deposition. The linear analysis results in a dispersion relation predicting the growth rate of interface deformations as a function of the perturbation wavelength. The model involves a three-component alloy in which the interface evolution is mediated by a surface catalyst, whose coverage of the interface is modeled explicitly.

In collaboration with Professor B. Andrews and coworkers at the University of Alabama in Birmingham and B. Murray at SUNY Binghamton, G. McFadden, K. Gurski, and S. Coriell (MSEL) have been developing a model of the growth of composites by directional solidification. Professor Andrews is growing composites in the microgravity conditions of space for “monotectic” systems in which liquid rods or plates within a solid phase are produced from a single phase liquid during the growth process. An outstanding question is to understand and control the factors that determine the inter-rod spacing of the composites, which is observed to be sensitive to the state of convection in the two liquid phases present. We have formulated a stability analysis to describe the dominant terms in a model of the interface separating the two liquid phases. A number of possibilities for convection occur in the system, including flow due to buoyancy, surface tension gradients, density changes at the interface, and pressure gradients at the interface.

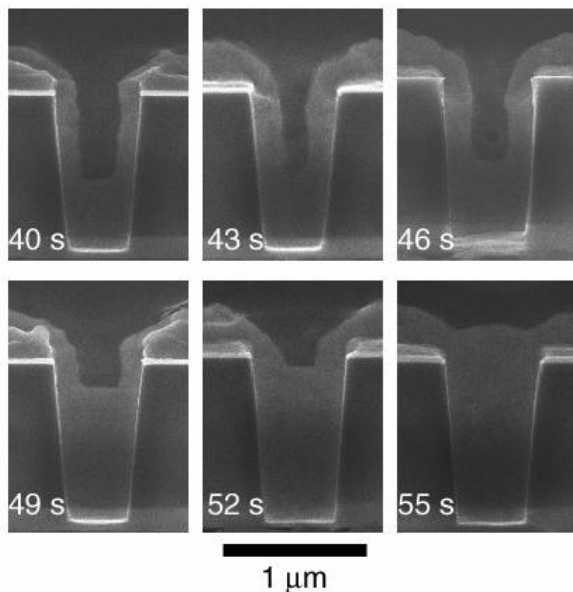

Picture from experimental showing the filling of a trench or “via” by electro-deposition. (Photo courtesy of D. Josell, B. Baker, C. Witt, D. Wheeler and T.P. Moffat, MSEL).



Shape instability of a quantum wire with a surface tension anisotropy having a three-fold axis of symmetry with respect to the wire centerline.

K. Gurski and G. McFadden have begun to study the stability of quantum wires in collaboration with researchers at Northwestern University, who have NSF funding for a Nanotechnology and Interdisciplinary Research Team. Quantum wires are nanoscale structures that are formed by deposition on a substrate, typically with a high lattice-mismatch that tends to produce aligned crystals on the substrate. The processing parameters that govern the growth and stability of the wires are a subject of intense current interest. In our work we are examining how the anisotropy of the surface energy of the wire affects its stability. As a first step, the effects of the substrate have been ignored, and the stability of the isolated wire (see figure) has been determined through both asymptotic and numerical analysis. The next stage of the work, in which the rod interacts with a substrate, is being performed in collaboration with Professor M. Miksis of Northwestern University.

**NIST Strategic Focus Areas.** *Established Industries:* Materials Processing. *Emerging Industries:* Nanotechnology.

## Polytope Visualization for High $T_c$ Ceramics

*Anthony Kearlsey*  
*Larry Cook (NIST MSEL)*  
*Winnie Wong-Ng (NIST MSEL)*

We have begun work to combine new computational methods with a recent conceptual breakthrough in the study of complex materials equilibria. This work is providing a novel means, and modern implementation, for the design of advanced materials, as well as for measuring and interpreting

specialized multidimensional materials data. Our approach utilizes polytopes (i.e., multidimensional, multifaceted, closed hypervolumes) for the quantitative representation of data in a readily visualizable, thermodynamically valid, and electronically transportable form. Recently we introduced what has come to be referred to as the *polytopic representation*, a new way to visualize information produced by high  $T_c$  ceramic experiments. Data produced from these experiments can take days or even weeks to assimilate. Using our procedure, material scientists can visualize the changes in superconductance as a function of chemical composition (see figures), potentially decreasing the need for additional experimentation and allowing more precise conclusions to be drawn.

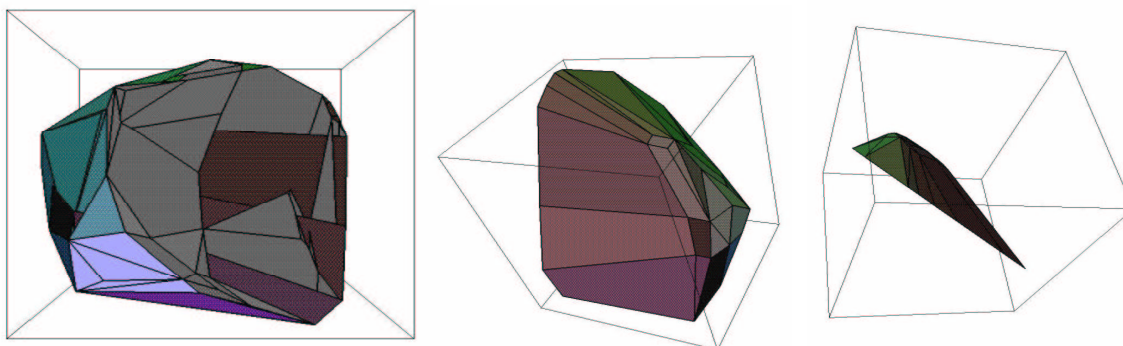

In the figures above one can see a polytopic projection of a complex seven-component Pb-free ceramic system. The polytope is a primary phase hypervolume (liquid region) defined by measurements of 23 invariant points.

We have received positive feedback on this work from many private sector companies, including Lucent, Carpenter Technology, Allied Signal, Rockwell, Howmet, Intermagnetics Gernal, and 3M. Recently, US industry representatives have suggested extensions of this technique to include thermodynamic/phase equilibrium theory, which is not yet included in our polytope calculations. We are planning extensions of our work to these cases.

**NIST Strategic Focus Areas.** *Established Industries:* Materials Processing. *Emerging Industries:* Information and Knowledge Management (dynamic data infrastructure).

## Micromagnetic Modeling

*Michael Donahue*

*Donald Porter*

*Robert McMichael (NIST MSEL)*

*Steve Russek (NIST EEEL)*

<http://math.nist.gov/oommf/>  
<http://www.ctcms.nist.gov/~rdm/mumag.html>

The engineering of such IT storage technology as patterned magnetic recording media, and spintronic devices such as GMR sensors, magnetic RAM (MRAM), and magnetic logic devices, requires an understanding of magnetization patterns in magnetic materials at the nanometer scale. Mathematical models are required to interpret measurements at this scale. The Micromagnetic Modeling Activity Group (muMAG) was formed to address fundamental issues in micromagnetic modeling through two activities: the definition and dissemination of standard problems for testing modeling software, and

the development of public domain reference software. MCSD staff is engaged in both of these activities, and maintains two e-mail lists for announcements and discussions. These lists contain 223 addresses representing 7 government labs, 76 universities (22 US), and 21 companies including IBM, HP, Seagate, ReadRite, and Honeywell.

The Object-Oriented MicroMagnetic Framework (OOMMF) software package is a reference implementation of micromagnetic modeling software being developed primarily by M. Donahue and D. Porter of MCSD. It is becoming an invaluable tool in magnetics research, with acknowledgement in over 20 journal papers in 2002, including articles in *Science* and *Physical Review Letters*. The latest version of the three-dimensional solver, released in October 2002, features extended methods for material properties specification, new solution methods, and a 170-page user's manual. The OOMMF code has been downloaded over 2000 times since October 2001.

Micromagnetic modeling is an important complement to experimental work on high-speed dynamics of magnetic thin-film devices being performed in the Magnetic Technology Division of EEEL. S. Russek (EEEL), with contributions by R. McMichael (MSEL), M. Donahue, and S. Kaka (University of Colorado, Boulder), has written a chapter for the book "Spin Dynamics in Confined Magnetic Structures II" being published by Springer-Verlag.

Other recent activities include presentations at the InterMag 2002 conference in Amsterdam (May 2002, M. Donahue and D. Porter), at the NIST Nanotechnology Open House in Gaithersburg (June 2002, M. Donahue), and two presentations at the Magnetism and Magnetic Materials conference in Tampa (Nov. 2002, M. Donahue).

In December 2002, the Department of Commerce Bronze Medal was awarded to M. Donahue, R. McMichael and D. Porter for their work on computational techniques for simulating the behavior of micromagnetic materials.

**NIST Strategic Focus Areas.** *Established Industries:* Information Technology, Materials Processing. *Emerging Industries:* Nanotechnology (nanomagnetism); Information and Knowledge Management (virtual measurement).

## Optimal Control of Bose-Einstein Condensates in Harmonic Traps

*Geoffrey McFadden*

*Charles Clark (NIST PL)*

*Peter Blakie (NIST PL)*

In collaboration with Charles W. Clark and P. B. Blakie (PL), G. McFadden, with help from T. Burns and A. Kearsley, considered a problem involving the control of an ordinary differential equation modeling the evolution of the configuration of an atomic trap. The model has the form of a second-order oscillator equation with non-linear forcing, and is intended to describe atomic Bose-Einstein condensates. For example, one may wish to transport a condensate from one place to another by moving the trap, or to change the condensate density by altering the trapping potential, and afterwards have the condensate in the ground state of the target trap configuration, ready for an experiment. The results indicate how to move from an initial trap configuration to an arbitrary target configuration by programming the time variation of trap parameters so that the condensate is at rest at the end of the process, even though it may be "excited" at intermediate stages. A simple constructive procedure for programming the time dependence of trap parameters to accomplish this objective was obtained. This enables one to make much faster and larger changes than would be possible under the usual criteria of adiabaticity.

**NIST Strategic Focus Areas.** *Emerging Industries:* Nanotechnology (quantum devices).

## Quantum Information

*Isabel Beichl*

*Ronald Boisvert*

*William Mitchell*

*David Song*

*Gavin Brennen (NIST PL)*

*John Martinis (NIST EEEL)*

*Eite Tiesinga (NIST PL)*

*Carl Williams (NIST PL)*

*Mike Robinson (IDA Center for Computing Sciences)*

*Francis Sullivan (IDA Center for Computing Sciences)*

The use of the principles of quantum physics for the storage, transformation, and communication of information has the potential to revolutionize information technology. This project seeks to complement and enhance NIST's existing experimental quantum information program, providing expertise to attack critical computer science and mathematics problems needed to transition this technology from laboratory experiments to realistic computing devices. In particular, we are developing algorithms and software tools to model quantum systems being engineered for computation in the NIST Physics Laboratory. We are also devising architectural concepts, such as the layout of processors and memory, techniques of communication between components, and implementation of error correction schemes, for quantum computers built from components under development at NIST. Integrated high-level designs of this type are critical to the practical realization of scalable quantum computers. Such studies will help the experimental program with design decisions that affect the reliability and scalability of potential computation devices. We will also demonstrate the utility of such designs in the context of novel quantum algorithms, validating the practicality of a given architecture, and providing demonstrations of actual computations on prototype processors that are realized. This work will greatly accelerate the transition of quantum computation from laboratory experiment to practical realization.

William Mitchell of MCS D has been working with Eite Tiesinga of the NIST Physics Lab to develop computer models of neutral atoms in laser traps to enable simulations for the design of quantum gates. These models require the solution of eigenvalue problems for the Schrödinger equation. The problems are challenging since interior eigenfunctions varying sharply over many orders of magnitude must be resolved. Mitchell's parallel adaptive grid refinement multigrid solver is being refitted for this purpose. An Arnoldi iteration is being used to compute the eigenvalues. The ground state has been successfully computed for the physical system under study, and some progress has been made in computing interior trapping states. An example eignefunction is displayed here.

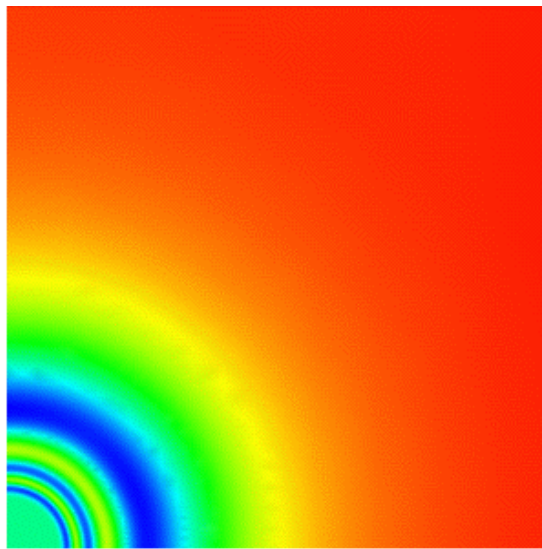

David Song, working with Carl Williams and Gavin Brennen of the NIST Physics Lab have developed an architecture for quantum computers based on lattices of trapped neutral atoms. In such a system, two qubit gates can only be physically realized between adjacent qubits, calling scalability into question. The NIST researchers have shown how to use ancilla qubits to form a quantum bus in which two qubit gates are teleported. The fidelity of the proposed operations exceeds that of the more laborious swapping of quantum states to physically move qubits into position. A paper describing the

quantum bus architecture has been submitted. David Song has subsequently begun a study of a theoretical implementation of Shor's factoring algorithm on such an architecture.

Isabel Beichl and David Song, working with Francis Sullivan and Mike Robinson of the IDA Center for Computing Sciences, are developing a quantum algorithm for determining if a mapping from a finite set to itself is one-to-one. Classical algorithms require  $n$  steps, but the new algorithm is expected to require only  $n^{1/2}$ . The proposed method, which is related to Grover's search algorithm, uses phase symmetry, results about the  $p$ th roots of unity, and the density of prime numbers in the integers. A paper is being written. Beichl has also written a report clarifying the proof of lower bounds on Grover's algorithm.

This year, the NIST Director selected a proposal entitled "Quantum Information Theory and Practice" for 5-year funding under the NIST Competence Program. The proposal, which was championed by Ronald Boisvert and Carl Williams, supports the work of the MCSD quantum information project. Ronald Boisvert continues to co-ordinate the ITL-wide quantum information program, which includes the development of a testbed for quantum key exchange. That system will be demonstrated during FY2003.

**NIST Strategic Focus Areas.** *Emerging Industries:* Nanotechnology (quantum devices).

## The APEX Image Sharpening Method in Scanning Electron Microscopy

*Alfred Carasso*

*András Vladár (NIST MEL)*

*John Villarrubia (NIST MEL)*

*David S. Bright (NIST CSTL)*

*Dale Newbury (NIST CSTL)*

The APEX method is a direct (non-iterative) blind deconvolution technique that uses FFT algorithms to implement Carasso's inverse diffusion approach to image deblurring. Two major papers on this method were published this year. A paper in the *SIAM Journal on Applied Mathematics* describes successful applications of this technique to a wide variety of real images arising from quite diverse imaging modalities. These include astronomical, Landsat, and aerial reconnaissance images, as well as MRI and PET brain scans. The second paper, in *Optical Engineering*, describes the use of this technique to significantly sharpen scanning electron microscope (SEM) imagery at NIST.

Viewed against the background of current highly active interest in nonlinear partial differential equations based deblurring techniques, the MCSD-developed methodology offers enormous advantages. First, the APEX algorithm performs blind deconvolution of 512x512 images in seconds on current desktop platforms. Second, and most significant, the method is engineered to recover fine-scale image structure to the full extent permitted by the level of data noise. Extensive controlled

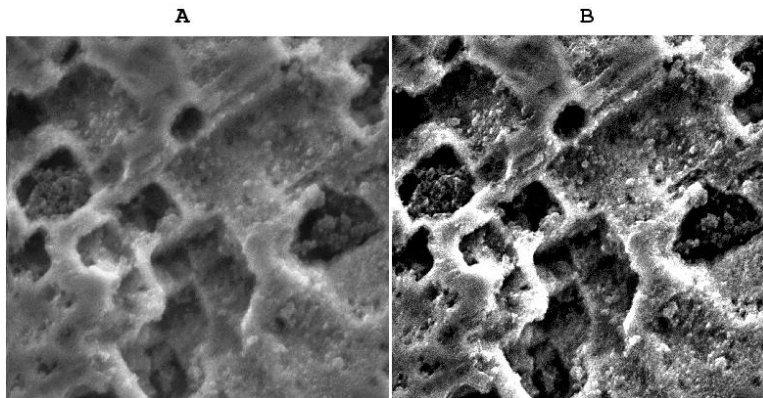

APEX processing of high-resolution 2048x2048 SEM micrograph reveals significant fine-scale structure. Such large-scale blind deconvolution is not feasible with currently known nonlinear techniques.



experiments on synthetic data, together with systematic comparisons with most other widely used deblurring algorithms, have confirmed this.

Current work with MEL and CSTL emphasizes high-resolution SEM images, typically of size 2048x2048, that are inaccessible by other techniques. This work aims at eventually identifying the true instrument point spread function. Another major aim is to arrive at a reliable way of quantifying image sharpness. The ability to reliably reconstruct small-scale details is a crucial element in ongoing research. An example of such reconstruction is shown in the figure above, where a typical high resolution SEM micrograph (A) is sharpened by APEX-processing (B).

**NIST Strategic Focus Areas.** *Emerging Industries:* Nanotechnology; Information and Knowledge Management.

## Numerical Algorithms for Advanced Mass Spectrometry

*Javier Bernal*

*Anthony Kearsley*

*Charles Guttman (NIST MSEL)*

*William Wallace (NIST MSEL)*

Mass spectrometry (MSpec) is an important technique for obtaining information about materials in a wide variety of applications. Loosely speaking, a mass spectrometer (see Figure 1) detects the presence of chemicals inside a sample suspended in a matrix by bombarding it with ions (with the help of a laser), and then counting the ions as they “bounce” off the prepared sample. Each chemical causes ions to bounce off in a different way, thus leaving a signature. If one is interested in testing for the presence of a particular chemical inside a sample material, an MSpec experiment can be designed to result in large peaks being produced when the chemical in question is detected. For example, one must identify, separate, and sum the matrix peaks present in the Bradykinin MSpec output in Figure 2. Because of its accuracy, this method for determining the presence of chemicals has been employed with more and more frequency by scientists.

While very detailed chemical procedures have been developed for MSpec sample preparation, very little work has been done on the development of numerical methods for the analysis of MSpec output. The objective of this project is to develop a reliable, and robust algorithm for *automatically* analyzing raw output from mass spectrometers and to demonstrate the algorithm by building a from-everywhere accessible public-domain web-based tool, making a high quality implementation of the algorithm widely available. The webtool is being constructed to directly analyze noisy mass spectrometer output, generating unbiased machine-independent analysis of the noisy data in a timely fashion, greatly reducing (or eliminating) the need for laborious and painstaking manual analysis.

Modern mass spectrometers produce astonishingly high-quality data. Scientists are regularly faced with the difficult and time-consuming task of sorting through enormous noisy data sets in search of structures (e.g., a “peak” or a “trough”) corresponding to the presence of chemical in question. Because of unavoidable measurement errors, test data can vary considerably when identical samples are analyzed with different equipment or in different laboratories. This expensive and time-consuming task is usually done with the aid of packaged computational algorithms, many of which are ‘black-box’ codes, sold by software vendors or by companies manufacturing mass spectrometer hardware. In practice, these codes are often massaged into performing correctly by changing large numbers of algorithmic input parameters and/or testing subsets of the output data independently before analyzing the entire mass spectrometer output. Numerical behavior of currently available software can vary drastically as a function of numerous extraneous factors, including parameter

selection, choice of peak shape for example, machine precision, and even the computer platform on which the software is being run. Simply put, this process is notoriously difficult.

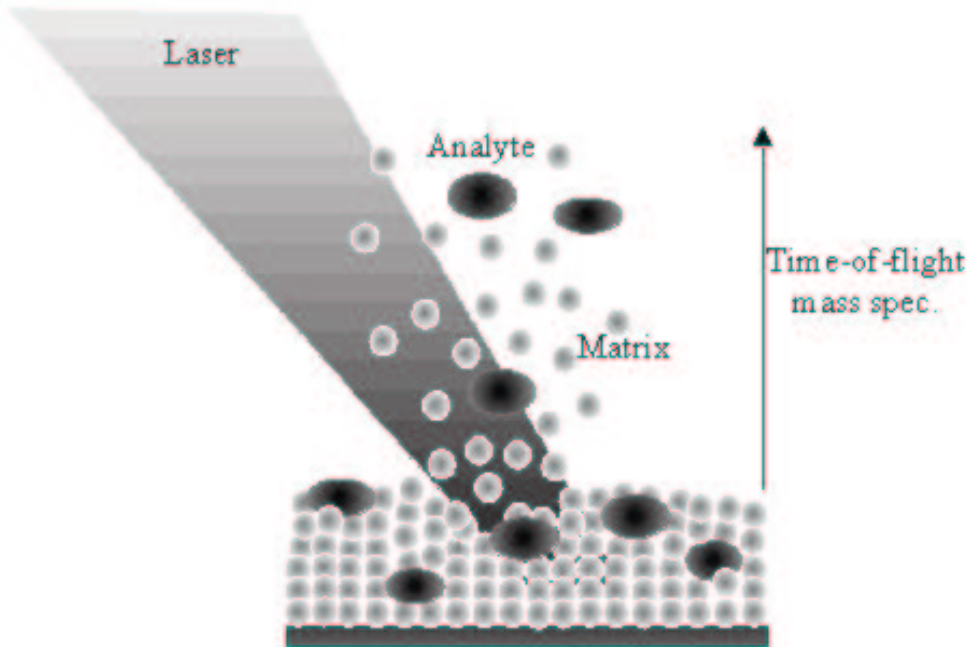
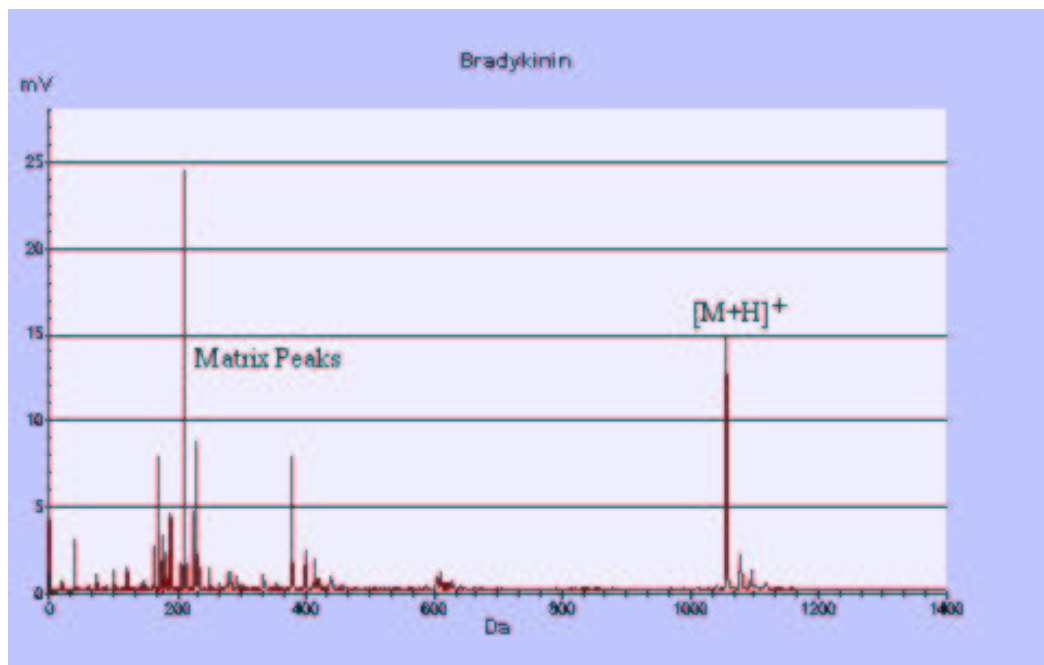

Figure 1: Illustration of MALDI Time-of-Flight Mass Spectrometer



We have succeeded in developing, implementing and testing an algorithm that, given raw MSpec data, can efficiently identify peak and trough structure without assuming any a priori size or shape structure. Preliminary results are promising, and the NIST Polymers Division is now using the algorithm regularly. We have received numerous requests for information, the most enthusiastic coming from a research group at the NIH.

**NIST Strategic Focus Areas.** *Homeland Defense. Emerging Industries:* Information and Knowledge Management.

## **Modeling Time-Domain Signals from Pulsed Excitation of Multiple Resonant Modes**

*Bert Rust*

*Ward Johnson (NIST MSEL)*

This project seeks to model the output of an ultrasonic resonance system designed for non-destructive testing of metals for cracks and flaws. A tone burst from a continuous sinewave reference drives the sample into resonance, creating a ringdown. An electromagnetic transducer detects the vibrations from this resonant ringdown and passes the signal to a receiver. The receiver contains two mixers that manipulate and filter the signal to produce two time-series outputs that, taken together, contain all of the useful information about the resonant ringdown. One of the signals is a linear combination of exponentially damped sinusoids, and the other a linear combination of damped cosines. The useful information consists of the frequencies and damping coefficients of the component vibrations. We have developed a nonlinear least squares algorithm for simultaneously fitting the two signals in order to estimate not only the frequencies and damping coefficients, but also the amplitudes and phase shifts of the component vibrations. Our program also estimates the statistical uncertainties in these parameters.

The two fits for an aluminum sample are shown in the Figures 1 and 2. These fits used 6 sine-cosine pairs. Two of the pairs were predicted by theory, and they dominate the fit, but the other four, which are of unknown origin, are statistically significant and necessary to reduce the residuals to white noise. The periodograms and cumulative periodograms for the residuals from the two fits are shown in Figures 3 and 4. The diagonal lines in the cumulative periodogram plots define the 95% confidence bands for white noise. Eliminating even one of the sine-cosine pairs from the model produces residual cumulative periodogram curves which lie outside of the 95% band at more than 5% of the frequencies.

The least squares program used to make the fits is Golub and Pereyra's variable projection code VARPO which separates the linear and nonlinear parameters, requiring initial estimates only for the latter (the frequencies and damping coefficients in this case). We were able to formulate the problem in such a way that no complex arithmetic was required. The fits made in developing our program isolated a number of errors and discrepancies in the instrumentation. For example, we were able to determine that small DC offsets are required in the model in order to compensate for imprecisions in the zero level of the two output channels. We are continuing our analysis to try to isolate the causes of the unexpected vibrations in the record.

**NIST Strategic Focus Areas.** *Established Industries:* Materials Processing. *Emerging Industries:* Information and Knowledge Management.

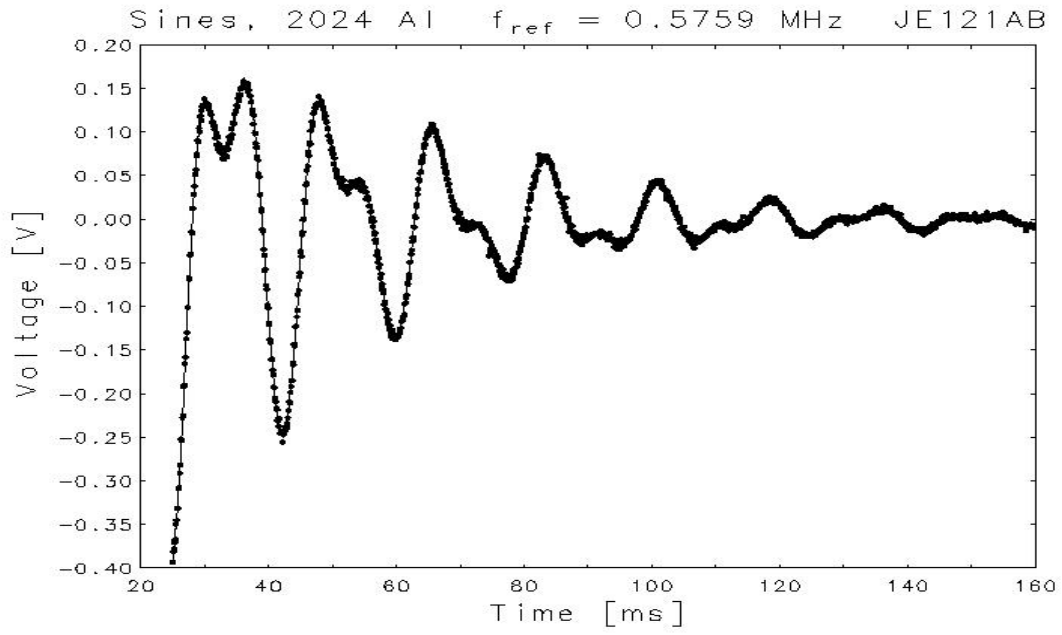

Figure 1

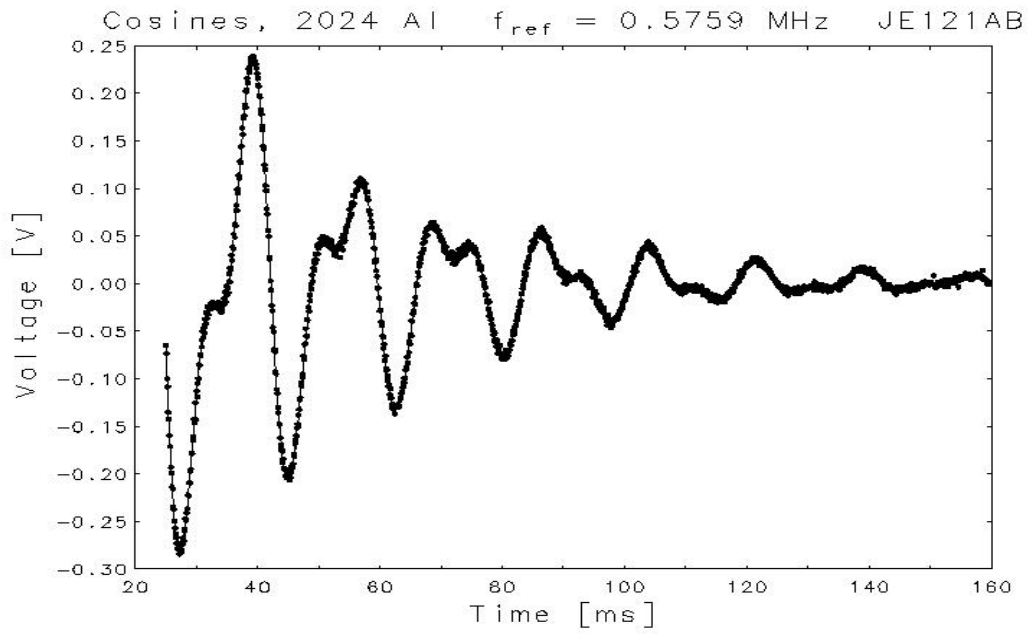

Figure 2

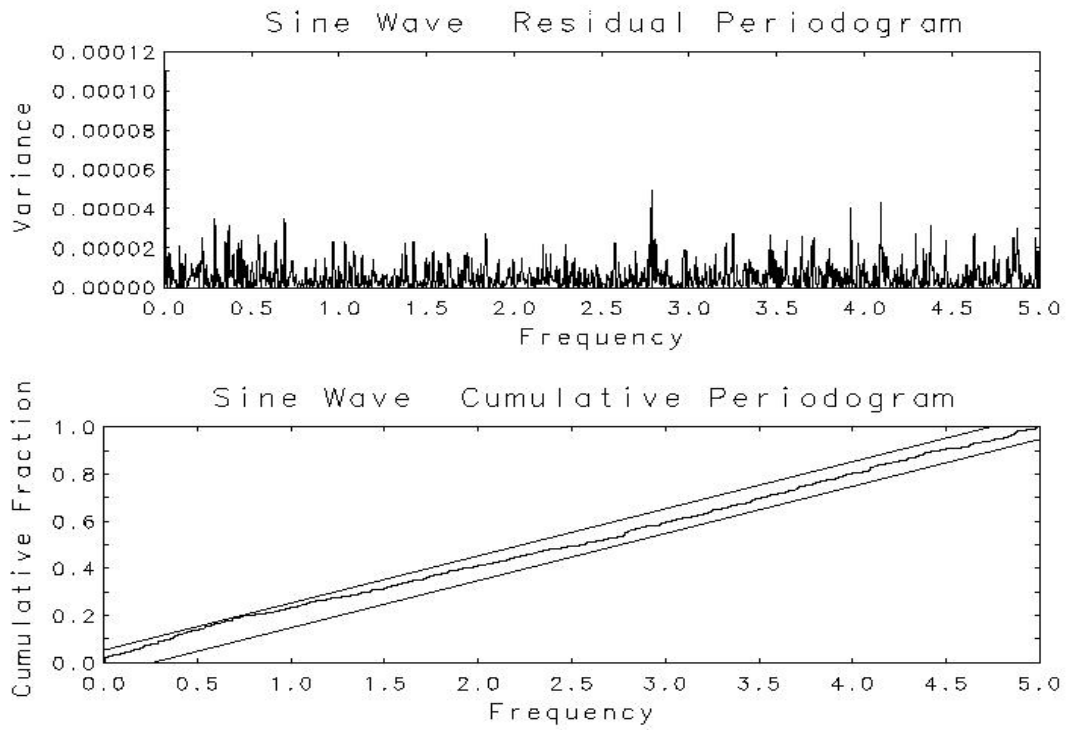

Figure 3

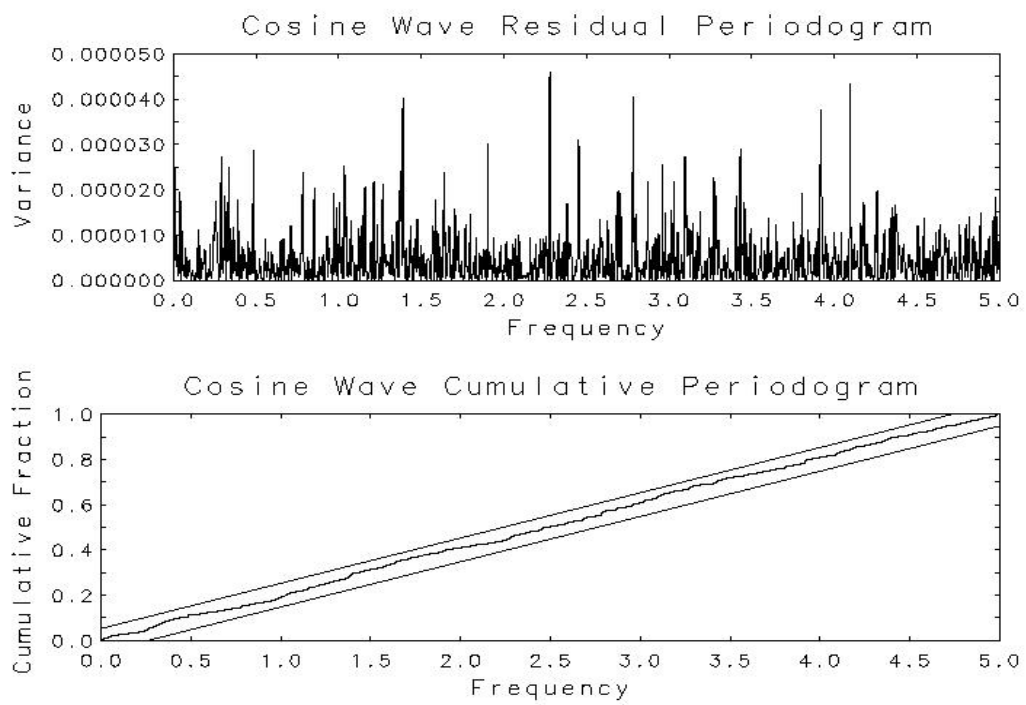

Figure 4

# Unfolding Measured Frequency Spectra of Permittivity in Polymers

Bert Rust

Oleksiy Anopchenko (NIST MSEL)

This project seeks to estimate the solution to an ill-posed problem that arises in measuring the electrical permittivity of polymers. Given measured real and imaginary frequency spectra, it is required to simultaneously invert real and imaginary first kind integral equations to obtain a single real relaxation time distribution. Figures 1 and 2 show selected frequency slices of the real and imaginary kernels. The functions for the imaginary kernel are not unreasonable, but the ones for the real kernel are similar to those in a numerical inversion of a Laplace transform and so are not encouraging. We have developed an algorithm that uses trapezoidal quadrature to discretize the two integral equations on the same relaxation time mesh, stacking the two resulting matrices and measurement vectors to produce a single ill conditioned linear regression model. To verify that our computer code was working correctly, we considered a problem whose solution was known to be a single very sharp peak. The measured real and complex frequency spectra are plotted in Figure 3 as 67% confidence interval bands.

Since the solution is very nearly a delta function, the measured spectra mimic the shapes of their corresponding kernel functions. We were able to recover good estimates of the true solution by several standard techniques including Tikhonov regularization, the truncated singular value method, and nonnegatively constrained least squares. We also obtained favorable results with Rust's new truncated singular component method, and good 95% confidence interval bounds (shown in Figure 4) using Rust and O'Leary's BRAKET-LS program.

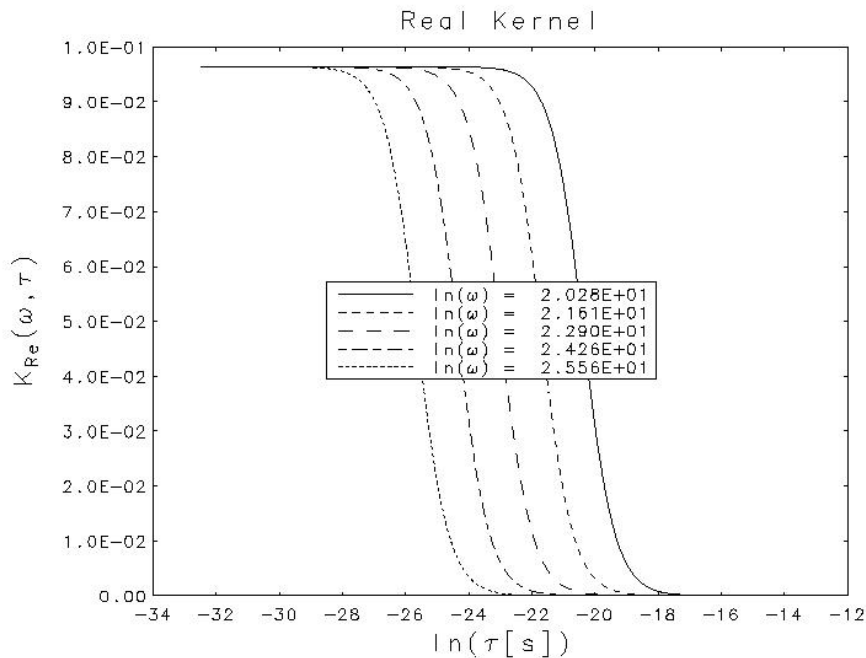

Figure 1: Selected frequency slices of real kernels.

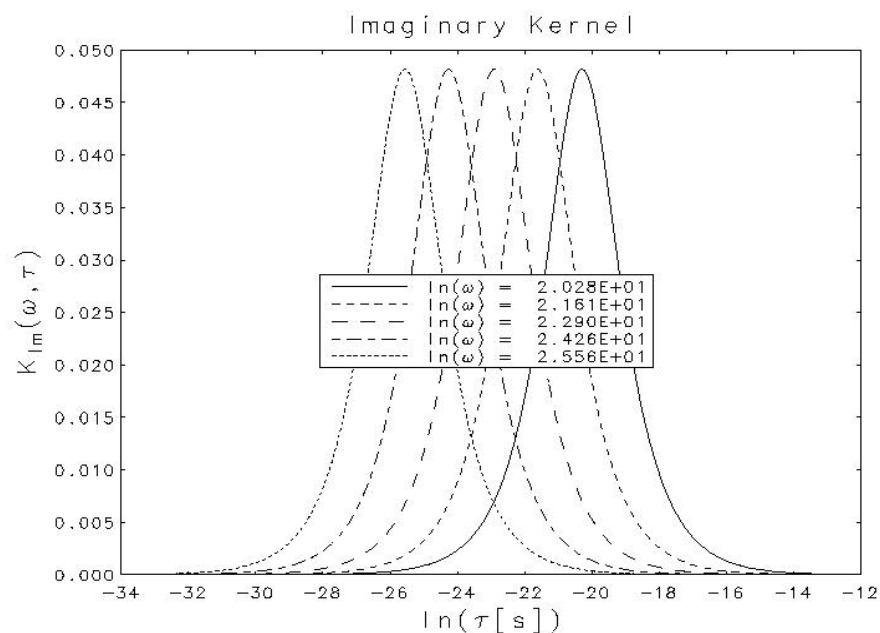

Figure 2: Selected frequency slices of imaginary kernels.

The problems of real interest to the Polymers Division involve glassy substrates that may prove very useful in extending the shelf life of proteins used in other areas of research. They are considerably more difficult than the above example, often having relaxation time distributions that have one or more discrete peaks superimposed on a background continuum. In such cases it is hard to judge the amount of regularization or smoothing needed to separate real peaks from spurious oscillations induced by the ill conditioning. Success in this endeavor will depend on good estimates of the measurement errors, which are often hard to obtain. There is also some evidence for correlations between the real and imaginary measurement errors. A considerable effort may be required to resolve all of these difficulties.

**NIST Strategic Focus Areas.** *Established Industries:* Materials Processing. *Emerging Industries:* Information and Knowledge Management.

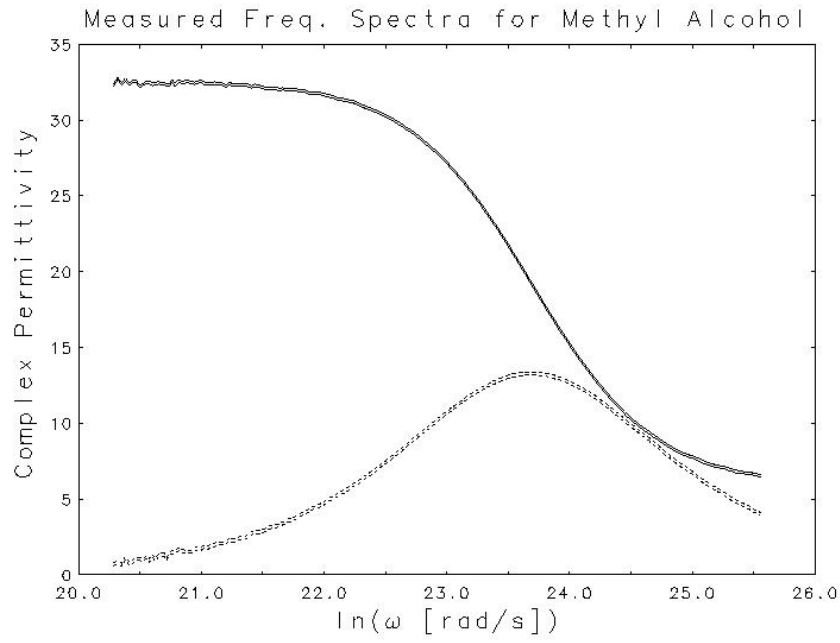

Figure 3: Measured real and complex frequency spectra

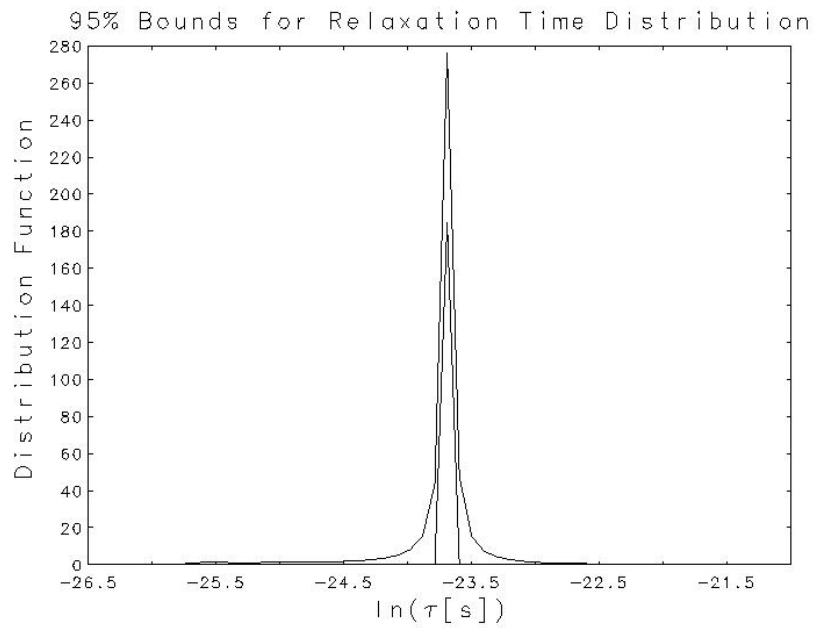

Figure 4



## Machining Process Metrology, Modeling and Simulation

*Timothy Burns*

*Debasis Basak (NIST MSEL)*

*Gerald Blessing (NIST MEL)*

*Brian Dutterer (NIST MEL)*

*Richard Fields (NIST MSEL)*

*Michael Kennedy (NIST MEL)*

*Lyle Levine (NIST MSEL)*

*Robert Polvani (NIST MEL)*

*Richard Rhorer (NIST MEL)*

*Eric Whitenton (NIST MEL)*

*Howard Yoon (NIST PL)*

This is an ongoing collaboration on the modeling and measurement of machining processes with researchers in the Manufacturing Process Metrology Group in the Manufacturing Metrology Division (MMD) in MEL. The mission of MMD is to fulfill the measurements and standards needs of the U.S. discrete-parts manufacturers in mechanical metrology and advanced manufacturing technology.

The main goal of our current efforts, which are in the final year of a three-year program supported in large part by intramural ATP funding, is to develop the capability to obtain and validate the *material response data* that are critical for accurate simulation of high-strain-rate manufacturing processes. Although the focus of this project is machining, the material response data will be broadly applicable. Success in this project will advance the state of the art in two different areas: (1) fundamental advanced machining metrology and simulation; and (2) measurement of fundamental data on the behavior of materials at high strain rates (material-response data) needed for input into machining (and more broadly mechanical manufacturing) simulations. A longer-term, higher-risk objective of this effort is the development of new test methods that use idealized machining configurations to measure high-strain-rate material response.

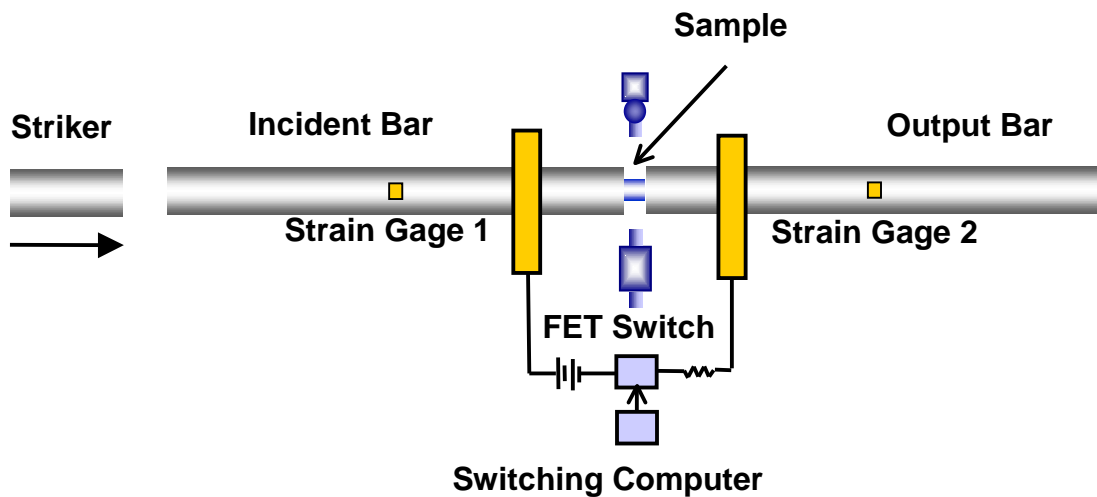

Schematic showing the rapid resistive pulse-heating capability that has been added to the NIST Kolsky Bar this fiscal year.



The NIST Kolsky Bar Facility in the Special Projects Building, showing the gas gun, bars, momentum trap, and data acquisition system.

The experimental apparatus that has been developed for this project combines an existing NIST pulse-heating system with a well-known method for high-strain-rate material testing called a Kolsky bar. In this facility, a small cylindrical sample of material that is sandwiched between two hardened steel bars is loaded dynamically by means of stress waves. Using this technique, dynamic material response data for the material can be obtained. The novel contribution of the NIST facility is a capability of preheating the sample rapidly before it is strained plastically. The NIST Kolsky Bar Facility has been successfully operated during FY2002 with over 100 logged tests. Room-temperature tests have included steel, copper, aluminum, and titanium samples. Even though it was not part of the original ATP proposal, the Kolsky bar team has been collaborating with other NIST researchers on the analysis of World Trade Center steel, by testing several room-temperature samples at high strain rate. Additional tests on these materials are planned for FY2003.

All four laboratories have collaborated on the materials testing and initial publication of results. The ability to preheat samples with a fast, controlled electrical pulse has been implemented and tested. Temperature measurement methods have been implemented and calibrations performed. FY2003 plans include some minor mechanical improvements and development of appropriate triggering and timing methods to control experiments accurately during both pulse heating and mechanical straining of material samples.

**NIST Strategic Focus Areas.** *Established Industries:* Manufacturing Engineering. *Homeland Security.* *Emerging Industries:* Information and Knowledge Management (virtual measurements).

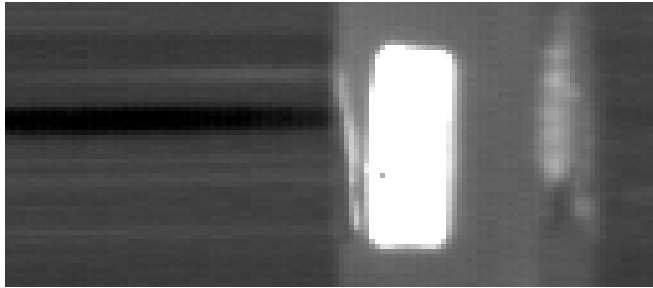

Frame from thermal imaging camera taken a few milliseconds after mechanical loading, showing a cylinder of AISI 1045 steel that has been heated by plastic working during rapid compression on the NIST Kolsky Bar Facility. The sample was originally 2mm thick by 4mm diameter, and at room temperature.

## **Mathematical Problems in Construction Metrology**

*Christoph Witzgall*

*Javier Bernal*

*David Gilsinn*

*G.S. Cheok (NIST BFRL)*

*William Stone (NIST BFRL)*

LADAR (Laser Radar) scanning of terrain and objects is playing an increasing role in various efforts such as construction monitoring, object recognition, target acquisition, and vehicle guidance. Consequently, there is a need for computational methods to process, analyze, and display the resulting typically large and noisy data sets. In contrast to photography, which produces a 2D projected image, LADAR scans provide a collection of 3D data points, given numerically by distance and bearing. A major task is to mesh such data clouds, that is, to represent them as surfaces. Typically, several LADAR scans are taken of the same scene, and need to be coherently combined or “registered”.

We are evaluating meshing and registration methods by conducting experiments in a controlled environment with known artifacts, and by statistically evaluating their numerical results. In particular, methods based on triangulated irregular networks or “TIN’s” are studied. Both meshing and registration aim for a “best” representation. They can therefore be conceptualized as optimization problems in which a chosen numerical measure-of-fit is optimized. Of major interest is the extent to which that choice affects the quality of the outcome. An additional question is the utility of TIN methods for data editing and object segmentation.

LADAR technology is also currently being tested for the automated identification of equipment on construction sites. A major effort during 2002 involved the use of LADAR to read bar codes for distant object identification. As a first step, a program was written to display distance and intensity responses of LADAR scans of bar code reflectance tape. A deconvolution program was written that allowed user-defined filters for the convolution integral as a method to reconstruct defocused LADAR scanned bar code images. Through a simulation, it has been shown that a detailed knowledge of beam characteristics allows reconstruction of bar codes. The simulated distortions began to compare favorably with actual LADAR images at the same ranges. Deconvolution calculations on the simulated distorted images recovered the original images remarkably well. The

simulation showed that an exact knowledge of the beam allowed accurate reconstruction of the bar codes. Filter models based on experimental results of measuring LADAR beams, using an infrared visual scope, were developed to simulate the distortion of bar code images from 10 m to 40 m. The beam used did not remain solid, but split into multiple sub-beams beyond 10 m. These observations affected the design of filters to deconvolve a set of LADAR images of reflective tape acquired by BFRL to simulate bar codes. Averaging filters were used with some success to deconvolve some of the images at the 10 m level. For larger distances the measurement of the particular LADAR device has shown a complex structure that makes determining a deconvolution filter particularly difficult. An attempt to measure the LADAR point spread function was also attempted by projecting the beam at small dots of reflector material. The coarseness of the beam made it difficult to distinguish the dots at 40 m.

This work was described in a paper entitled “Reconstructing Images of Bar Codes for Construction Site Object Recognition” by D. Gilsinn, G. Cheok, and D. O’Leary which was presented at the 19<sup>th</sup> International Symposium on Automation and Robotics in Construction held at NIST, Gaithersburg, MD 23-25 September 2002. The paper received the Best Paper Award from the conference program committee.

**NIST Strategic Focus Areas.** *Established Industries:* Construction Engineering. *Emerging Industries:* Information and Knowledge Management (dynamic data infrastructure).

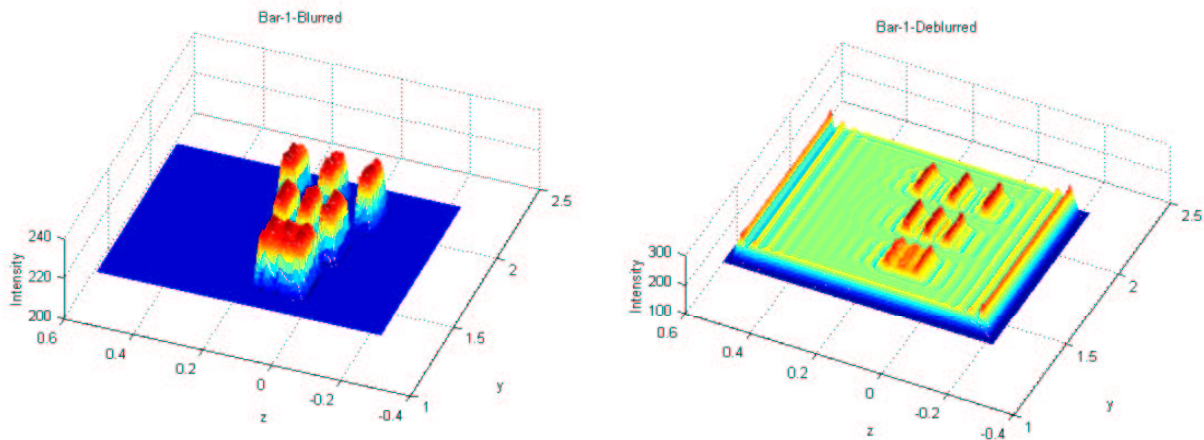

Deconvolution of 1 inch bars 10 meters away. On the left is the measured intensity; while on the right is the output of the deconvolution.