

VIIth International Pneumoconioses Conference



Proceedings - Part II
Transactions - Tome II
Transacciones - Parte II

August 23 - 26, 1988
Vista International Hotel
Pittsburgh, Pennsylvania
USA



U.S. DEPARTMENT OF HEALTH AND HUMAN SERVICES
Public Health Service
Centers for Disease Control
National Institute for Occupational Safety and Health

CDC
CENTERS FOR DISEASE CONTROL

Proceedings of the VIIth International Pneumoconioses Conference Part
Transactions de la VIIe Conférence Internationale sur les Pneumoconioses Tome
Transacciones de la VIIa Conferencia Internacional sobre las Neumoconiosis Parte

II

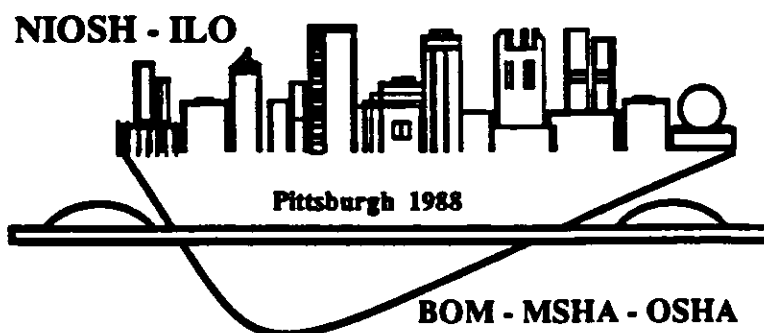

Pittsburgh, Pennsylvania, USA—August 23-26, 1988
Pittsburgh, Pennsylvanie, Etats-Unis—23-26 août 1988
Pittsburgh, Pennsylvania EE. UU—23-26 de agosto de 1988



U.S. DEPARTMENT OF HEALTH AND HUMAN SERVICES
Public Health Service
Centers for Disease Control
National Institute for Occupational Safety and Health



Sponsors

International Labour Office (ILO)
National Institute for Occupational Safety and Health (NIOSH)
Mine Safety and Health Administration (MSHA)
Occupational Safety and Health Administration (OSHA)
Bureau of Mines (BOM)

November 1990

DISCLAIMER

Sponsorship of this conference and these proceedings by the sponsoring organizations does not constitute endorsement of the views expressed or recommendation for the use of any commercial product, commodity, or service mentioned.

The opinions and conclusions expressed herein are those of the authors and not the sponsoring organizations.

DHHS (NIOSH) Publication No. 90-108 Part II

VIIth International Pneumoconioses Conference

Organizers:

The National Institute for Occupational Safety and Health (NIOSH)
The Mine Safety and Health Administration (MSHA)
The Occupational Safety and Health Administration (OSHA)
The United States Bureau of Mines (BOM)

in cooperation with the:

International Labour Office (ILO), Geneva

Conference Staff:

<i>Chairman</i>	Edward L. Baker, M.D.
<i>Former Chairman</i>	Robert E. Glenn
<i>Vice-Chairman</i>	Georg Kliesch
<i>Executive Secretary-General</i>	Jack Berberich, Ph.D.
<i>Scientific Secretary-General</i>	Robert Reger, Ph.D.
<i>Assistant Chair — Scientific Papers</i>	Molly Pickett-Harner
<i>Assistant Chair — Logistics</i>	Robert Wheeler
<i>Assistant Chair — Finances</i>	Fred Ames
<i>Special Assistant to Chair</i>	Mitzie Martin
<i>Secretary to Executive Secretary-General</i>	Lunette Utter

INTERNATIONAL ORGANIZING COMMITTEE

Edward L. Baker, M.D., Chairman
Robert E. Glenn, Former Chairman
NIOSH

Georg Kliesch, Vice Chairman
ILO

Edward J. Baier, M.P.H.
OSHA

John A. Breslin, Ph.D.
BOM

George Coppee, M.D.
ILO

Alois David, M.D.
ILO

Morton Lippman, Ph.D.
New York University

Peter Turcic, M.P.A.
MSHA

Hans Weill, M.D.
Tulane University

Jerome F. Wiot, M.D.
University of Cincinnati

NATIONAL ORGANIZING COMMITTEE

Edward L. Baker, M.D., Chairman
NIOSH

Robert E. Glenn, Former Chairman
NIOSH

Edward J. Baier, M.P.H.
OSHA

Philip J. Bierbaum, M.S.
NIOSH

Daniel D. Braun, M.D.
Industrial Health Foundation

John A. Breslin, Ph.D.
BOM

Morton Corn, Ph.D.
The Johns Hopkins University

Edgar Dessen, M.D.
Hazelton Radiology and
American College of Radiology

Philip Enterline, Ph.D.
University of Pittsburgh

Lawrence J. Fine, M.D.
NIOSH

James E. Hertzog, M.D.
Consolidation Coal Company

Lorin E. Kerr, M.D.
United Mine Workers of America

Jerome Kleinerman, M.D.
Cleveland Memorial General Hospital

Morton Lippmann, Ph.D.
New York University Medical Center

Roger O. McClelland, D.V.M.
Lovelace Biomedical and Environmental
Research Institute

James A. Merchant, M.D.
University of Iowa

E. Nicholas Sargent, M.D.
University of Southern California

Joseph J. Schwerha, M.D.
United States Steel Corporation

Peter M. Turcic, M.P.A.
MSHA

James L. Weeks, Sc.D.
United Mine Workers of America

Hans Weill, M.D.
Tulane University

Jerome F. Wiot, M.D.
University of Cincinnati

Mike Wright, M.S.
United Steel Workers of America

Mario Battigelli, M.D.
West Virginia University

PREFACE

It is truly an honor and privilege to provide this preface to the Proceedings of the Seventh International Pneumoconioses Conference which was conducted in Pittsburgh, Pennsylvania during August 23-26, 1988. This symposium, only the seventh such conference since 1930 and the first to be held in the United States, was conducted under the joint sponsorship of the International Labour Office (ILO), the National Institute for Occupational Safety and Health (NIOSH), the Mine Safety and Health Administration (MSHA), the Occupational Safety and Health Administration (OSHA), and the Bureau of Mines (BOM).

The Pittsburgh Conference was attended by over 1000 participants from 50 countries. The symposium call for papers was issued in 1987 and invited submission of abstracts focusing on research and scientific expertise on the pneumoconioses and other occupational respiratory disease. The response was truly gratifying and resulted in the acceptance of over 275 papers for presentation in various scientific sessions and workshops and 124 papers for presentation at poster sessions. The Proceedings (Part II) now in your hand contains over half of those presented at the Conference.

It is my pleasure to acknowledge with gratitude the invaluable assistance of the many individuals and organizations which contributed to the planning, conduct and follow-up of this Conference. The International Organizing Committee was extremely helpful in developing the framework of the Conference. Special thanks to the National Organizing Committee who generously gave of their time and talents so that this Conference was truly representative of an event of its preeminent stature. I wish to publicly thank Mr. John Pendergrass, Assistant Secretary of Labor, OSHA and Mr. David Taylor, Deputy Director General, ILO for their inspiring keynote presentations; to Dr. J. Donald Millar, Assistant Surgeon General, Director of the National Institute for Occupational Safety and Health, Mr. Lynn Williams, International President, United Steel Workers of America and Dr. Bruce Karrh, Vice President, Safety, Health and Environmental Affairs, E.I. Dupont de Nemours Co., USA for their incisive overview presentations; and to the many staff of NIOSH who worked tirelessly in the conduct of the Conference. All were important partners in this enterprise.

But there could have been no successful venture without the enthusiastic and committed support of two people. Dr. Jack Berberich who when called upon at a critical time served both as Executive Secretary-General of the Conference and Editor-in-Chief of these Proceedings and Mr. Georg Kliesch, ILO.

Part III, summaries of *Work Group Sessions I-VI*, will be printed under separate cover. On behalf of the International and National Organizing Committees, the five sponsoring organizations, these Proceedings (Part II) are presented with the hope that you will find them as rewarding as your participation in the Conference.



Edward L. Baker, M.D., M.P.H.
Chairman
VIIth International Pneumoconioses Conference



Georg Kliesch
Vice Chairman
VIIth International Pneumoconioses Conference

ACKNOWLEDGEMENTS

The International Labour Office, The National Institute for Occupational Safety and Health and the other sponsoring organizations wish to thank the following NIOSH employees for their diligent effort in the preparation of this document: Sandra K. Poulson, Terry S. Stewart, Helen A. Michael, Sharon K. Smith, Patricia Amendola, Judith A. Justis, Dorothy K. Basile, Martha W. Saab, Lunette Utter, Beverly J. Carter, Katherine S. Orosz and Anita L. Wolfe for their outstanding clerical and typing support; Carol Welch for the many hours she devoted to the electronic scanning of technical papers; Richard Carlson for assistance in the sizing and insertion of all charts, tables, graphs and photos into the text; Anne Stirnkorb for assistance in the pagination of Part I of the Proceedings; and especially, Pauline Elliott who spent literally hundreds of hours providing editorial assistance, inserting the necessary scientific symbols, organizing, formatting and, where necessary, typesetting this entire document.

Special recognition and appreciation is given to all of the NIOSH staff who assisted in the planning and preparation for the various activities during and after the Conference.

Patricia A. Amendola
Larry Boyce
Beverly J. Carter
Janice E. Downey
Rebecca J. Gregory
Kelly C. Johnson
Gloria H. Lilley
Mitzi L. Martin
Delores A. Morris
Sandra K. Poulson
Martha W. Saab
Terry S. Stewart
Robert W. Wheeler

Jennifer Ballew
Richard A. Carlson
Carole J. Clinger
Brian Dugan
David K. Hilling
Judith A. Justus
Pervis C. Major II, Ph.D.
Helen A. Michael
Katherine S. Orosz
Mary Jo Powell
Sharon K. Smith
John T. Straface

Jack Berberich, Ph.D.
Shirley M. Carr
Charlotte A. Dalton
Pauline J. Elliott
Richard T. Jacob
Kathleen B. Kinsley
Michelle L. Malone
Michael L. Moore
Molly Pickett-Harner
Robert Reger, Ph.D.
Nikki A. Snyder
Lunette K. Utter

TABLE OF CONTENTS

	Page
Preface	v
Acknowledgements	vi
SCIENTIFIC PAPERS	
ANIMAL MODELS—PNEUMOCONIOSIS I	
Biological Effects of Short Fibers	835
<i>J.C. Wagner</i>	
ANIMAL MODELS—PNEUMOCONIOSIS II	
Experimental Study of Fibrosis Effect of Polypropylene and Polyethylene Dust on Rat Lungs	840
<i>Liu Zhuayuan, et al.</i>	
HAZARD EVALUATIONS/CLINICAL STUDIES II	
Apical Pleuropulmonary Changes in Persons Exposed to Asbestos—Experience from 40 Patients	845
<i>Gunnar Hillerdal</i>	
Radiographical Appearance of Talcosis and Composition of Talc	846
<i>Zhao Jinduo, et al.</i>	
Pulmonary Alveolar Proteinosis and Cement Dust: A Case Report—A Preliminary Report	852
<i>Robert J. McCunney, et al.</i>	
INSTRUMENTATION FOR DUST MEASUREMENT	
Personal Dust Sampling with the CIP-10 for a Better Medical Management of the Pneumoconiosis Risk in Coal Mines	862
<i>M. Zitter, et al.</i>	
EPIDEMIOLOGY—SILICA & ASBESTOS	
Pulmonary Function Changes in Vermont Granite Workers	870
<i>William G.B. Graham, et al.</i>	
PREVENTION/INTERVENTION	
Arbeitsmedizinische Vorsorgeuntersuchungen für Quarzfeinstaubgefährdete Beschäftigte in der Bundesrepublik Deutschland	873
<i>Siegfried Knobloch</i>	
GENERAL EPIDEMIOLOGY	
Prevalence of Radiographic Small Lung Opacities and Pleural Abnormalities in a Representative Sample of Adult Finns {ABSTRACT}	875
<i>A.J. Zitting, et al.</i>	
Occupational Asthma in Meat Workers Exposed to Proteolytic Enzymes {ABSTRACT}	876
<i>S.K. Galson, et al.</i>	
The Effects of Agricultural Dusts on Human Health in Shanghai Area	877
<i>Shen Yi-E, et al.</i>	
Occupation Induced Pulmonary Disease in a Wafer Board Manufacturing Plant, Colorado {ABSTRACT}	879
<i>T.R. Hales, et al.</i>	
Byssinosis: Respiratory Problems among Cotton Textile Mill Workers in Ethiopia	880
<i>Wolde Yohannes Mentessinot, et al.</i>	
Respiratory Symptoms and Dust Exposure in the Wool Textile Industry	892
<i>R.G. Love, et al.</i>	
ANIMAL MODELS OF PNEUMOCONIOSIS V	
Aluminum Inhalation Reduces Silicosis in a Sheep Model	895
<i>R. Bégin, et al.</i>	
Pulmonary Toxicity of Illite and Kaolin Dusts	897
<i>H. Daniel, et al.</i>	

ANIMAL MODELS OF PNEUMOCONIOSIS V (cont'd)

Toxicological Evaluation of Asbestos Substitute	900
<i>O. Rahman, et al.</i>	
Study of Effect of Different Kind of Short Asbestos on Lung of Rats	907
<i>Yang Meiyu, et al.</i>	
Acute Toxicity of Fly Ash Collected from a Municipal Incinerator Burning Trash	913
<i>Y. Alarie, et al.</i>	

ASBESTOS, PLEURAL PATHOLOGY, LUNG FIBER BURDEN II

Asbestos Related Diffuse Pleural Fibrosis	915
<i>A.R. Gibbs, et al.</i>	
Hyaline Pleural Plaques and Asbestos Exposure	919
<i>C. Bianchi, et al.</i>	
Morphology, Character and Features of Antophyllite-Induced Mesotheliomas {ABSTRACT}	924
<i>K. Kolev</i>	
Cell Types of Asbestos Lung Cancer {ABSTRACT}	925
<i>Coleman B. Rabin, et al.</i>	

TOXICITY/SURFACE CHARACTERIZATION III

Release of a "Fibroblast Proliferation Factor" from Human Macrophages <i>In Vitro</i> Treated with Quartz Dust DQ 12 or Coal Mine Dusts	926
<i>N.H. Seemayer, et al.</i>	
Use of a Sensitive Electro-Optical Method to Quantify Superoxide Production from Single Pulmonary Alveolar Macrophages Exposed to Dusts <i>In Vitro</i> or <i>In Vivo</i> : Some Current Experimental and Model Results	930
<i>Eugene V. Cilento, et al.</i>	
An Attempt for Evaluation of the Alveolar Dust Deposition on the Base of the Particle Size Distributions of Lung Dusts	933
<i>Stoyna Ivanova-Djoubrilova, et al.</i>	
The Biological Effect of Particle Size Distribution of Quartz Component in Polymineral Dusts	938
<i>M. Dobрева, et al.</i>	
Chemiluminescence and Biologic Reactivity of Freshly Fractured Silica	943
<i>N.S. Dalal, et al.</i>	
The Injurious Effect of Quartz on Cell Membranes and the Preventive Effect of Aluminum Citrate Against Quartz	947
<i>Cheng J. Cao, et al.</i>	

DISABILITY OUTCOMES/OCCUPATIONAL LUNG DISEASES

Changes in Compensation for Occupational Lung Disease in Britain over 34 Years	954
<i>T.J.G. Phillips</i>	
Interobserver Variability Using the ILO (1980) Classification in Subjects Referred for Compensation Evaluation ..	960
<i>George L. Delclos, et al.</i>	
Legal Requirements for Medical Surveillance of Asbestos Workers in Malaysia, the USA and under International Law	965
<i>Krishna G. Rampal, et al.</i>	
Compensating Victims of Occupational Lung Disease: the Physicians Role in the System	972
<i>Stephen I. Richman</i>	
Product Stewardship or Bans? Asbestos in the Third World	975
<i>Barry I. Castleman</i>	

SURVEILLANCE/SCREENING/HEALTH REVIEWS II

Value of Screening Spirometry in Epidemiologic Studies of Pneumoconiosis {ABSTRACT}	978
<i>G.W. Frank, et al.</i>	
Pneumoconiosis of Delayed Apparition: Large Scaled Screening in a Population of Retired Coal Miners of the Northern Coal Fields of France	979
<i>P. Francois, et al.</i>	
Prevalence of Silicosis among Ceramic Industries Workers in the City of Pedreira, Brazil {ABSTRACT}	985
<i>José Inacio de Oliveira, et al.</i>	
Multiple Cause-of-Death Data in Pneumoconiosis Surveillance and Research {ABSTRACT}	986
<i>L. Wideroff, et al.</i>	

CONTENTS (continued)

SURVEILLANCE/SCREENING/HEALTH REVIEWS II (cont'd)

National Survey of Pneumoconiosis Supervision in Japan	987
<i>Yoshiharu Aizawa, et al.</i>	
An Historical Review of Airborne Coal Dust Levels and the Prevalence of Occupational Lung Disease in New South Wales Coal Mines 1948-1988	990
<i>Robert Griffiths</i>	
Report on the "International Symposium on Pneumoconioses" in Shenyang, China, 30 May-2 June 1988	994
<i>H. Idel, et al.</i>	

SAMPLING AND CONTROL OF MINERAL DUST

Reducing Bag Operator's Dust Exposure in Mineral Processing Plants	996
<i>Andrew B. Cecala, et al.</i>	
Reconstruction of Thirty Years of Free Silica Dust Exposure in the Taconite Industry	1001
<i>J.W. Sheehy, et al.</i>	
One Solution to Control—Careful Application of Known Technology {ABSTRACT}	1007
<i>K.J. Caplan</i>	
Dust Control and Occupational Exposure to Silica in the United Kingdom	1008
<i>J. Tickner</i>	
Auxiliary Ventilation Plant and Air Dispersed Particulates: An Experimental Study in the Stopes of an Italian Talc Mine	1011
<i>C. Clerici, et al.</i>	
A Respirable Dust Survey of Various Metalliferous Mine Sites in Queensland, Australia	1019
<i>S.L. Bell, et al.</i>	

RESPIRATORS AND DUST CONTROLS

The Achievements in Dust-Control and Dustproof Measures Taken Since the Founding of the People's Republic of China	1025
<i>Qihua Qin, Eng. B.</i>	
Risk Assessment of Pulmonary Exposure to Respirable Dust while Wearing Dust Respirator under Simulated Work Conditions	1027
<i>Behzad S. Samimi</i>	
Respiratory Protection Equipment Performance Standards in Developing Countries	1035
<i>D.P. Wilmes, et al.</i>	
Optimization of Freely Suspended Exterior Hoods in Industrial Ventilation	1037
<i>Nurtan A. Esmen, et al.</i>	
Significant Reduction of Quartz Dust Concentrations in the Nature Stone Industry Due to the Introduction of Ventilation Systems	1043
<i>Robert Feighofen</i>	
Explorations to Some Problems in Establishing Dust Allowable Concentrations	1046
<i>Liu Zhanyuan, et al.</i>	

EXPOSURE ASSESSMENT AND CONTROL ASBESTOS/OTHER FIBROUS MATERIAL

Criteria for Determining Work Related Heavy Asbestos Exposure	1049
<i>K.C. Wan, et al.</i>	
Asbestos Exposure among Construction Workers	1053
<i>Naomi Hisanaga, et al.</i>	
Dust Exposure Results in 359 Asbestos-Using Factories from 26 Countries	1059
<i>Daniel Bouige</i>	
Discriminating Amphibole Cleavage Fragments from Asbestos: Rationale and Methodology	1065
<i>A.G. Wylie</i>	
A New Fibrogenic Dust Sampling Method for Epidemiology of Pneumoconiosis {ABSTRACT}	1070
<i>Y. Hammad, et al.</i>	
System for Protection Against Exposure to asbestos in a Factory for De-insulation of Railway Cars	1071
<i>B. Sperduto, et al.</i>	

PATHOLOGY—HUMAN STUDIES II

Environmental Pulmonary Mineral Burden Correlated with Smoking, Pulmonary Emphysema and Lung Cancer .	1077
<i>O. Taikina-Aho, et al.</i>	
Element Analyses in Human Lung Tissue Correlated with Smoking, Emphysema and Lung Cancer	1083
<i>P.L. Kalliomäki, et al.</i>	

CONTENTS (continued)

PATHOLOGY—HUMAN STUDIES II (cont'd)

Lung Fibrosis Associated with Rare Earth Exposure	1087
<i>J.R. Ruettner, et al.</i>	
Coal Workers' Pneumoconiosis Lesions and Their Correlation to Dust Load {ABSTRACT}	1089
<i>V. Vallyathan, et al.</i>	

PARTICLE CHARACTERIZATION, EXPOSURE MEASUREMENT AND CONTROL

Feedback of Cleaned Exhaust Air into Workplace Atmospheres—Experiences on Testing Equipment	1090
<i>Helmut Blome, et al.</i>	
Exposures of End-Users to Airborne Concentrations of Fibrous Glass During Installation of Insulation Products and Fabrication Operations	1094
<i>C.W. Axten, et al.</i>	
Exposure of Workers to Respiratory Hazards at Columbus Coal and Refuse Municipal Electric Plant	1098
<i>Ibrahim M. Sobeih</i>	
Comparison of Number and Respirable Mass Concentration Determinations	1106
<i>T. Tomb, et al.</i>	
Size Distribution of Respirable Coal Mine Dust {ABSTRACT}	1111
<i>P.C. Thakur, et al.</i>	
Performance of Respirable Dust Sampling Systems in Underground Coal Mines	1112
<i>C.Y. Hwang, et al.</i>	

STRATEGIES FOR MINE DUST MEASUREMENT

Measurement Strategies in U.S. Underground Coal Mines	1124
<i>Thomas F. Tomb</i>	
The Threshold Limit Value for Various Forms of Amorphous Silica	1134
<i>Ronald S. Ratney</i>	
Comparison of the Sampling Strategies Recommended by the European Communities for the Protection of Workers from the Risks Related to Chemical Agents at Work, Asbestos, Lead and Mine Dust	1136
<i>B. Pr�at</i>	
Analysis of Respirable Coal Mine Dust Samples by Infrared Spectroscopy	1142
<i>P. Parobeck, et al.</i>	
Effect of the Measuring Strategy on the Determination of the Respirable Dust Concentration in the Breathable Air at Underground Workplaces	1148
<i>Bernhard Prinz, et al.</i>	
Respirable Dust and Free Silica Variation in Mine Environments	1152
<i>Thomas A. Hall, et al.</i>	

PATHOLOGY CLASSIFICATION AND GRADING SCHEMATA FOR SILICOSIS
—SPECIAL PRESENTATION

Newer Concepts in Silica and Silicate Lung Disease	1160
<i>A.R. Gibbs</i>	
Silica—Is It a Carcinogen in the Respiratory Tract?	1162
<i>John E. Craighead</i>	

POSTER SESSIONS I-IV

POSTER SESSION I

The Fibrosis and Other Morphologic Changes of Rat Lung Caused by Intratracheal Injection of Different Sizes of Metallic Aluminum Dusts	1167
<i>Zhou Chen, et al.</i>	
Respiratory Symptoms and Lung Function in Jute Processing Workers: A Primary Investigation	1172
<i>Zhou Chen, et al.</i>	
Relationship Between Serum Lipid Peroxides and Some Immunological Parameters in Silicosis	1178
<i>E. Tufanoiu, et al.</i>	
Raman Spectroscopic Studies on the Mechanisms of Membrane Damage Induced by Quartz and the Protective Effect of Aluminum Citrate	1181
<i>Cheng J. Cao, et al.</i>	
Study of Fibrogenic Effects of Slag Cement and Its Raw Materials on Rat Lung {ABSTRACT}	1186
<i>Yang Meiyu, et al.</i>	

POSTER SESSION I (cont'd)

Features of Calcified Silicosis and Its Prognosis {ABSTRACT}	1187
<i>Zhao Jinduo, et al.</i>	
Development of a New Personal Exposure Measurement System Considering Pulmonary Ventilation	1188
<i>Toshiaki Higashi, et al.</i>	
Carborundum Pneumoconiosis	1193
<i>R. Bégin, et al.</i>	
Imaging the Pneumoconioses in 1988: A Multidisciplinary Approach	1195
<i>R. Bégin, et al.</i>	
Experience with the ILO Classification (1980) in Relation to Exposure Time in \$ Coal Mines in the FRG {ABSTRACT}	1198
<i>W.T. Ulmer, et al.</i>	
Lung Function Measurements on Coal Miners {ABSTRACT}	1199
<i>W.T. Ulmer, et al.</i>	
Visceral Pleural Thickening in Asbestos Exposure: The Occurrence and Implications of Thickened Interlobar Fissures	1200
<i>S. David Rockoff, et al.</i>	
Prevalence of Clinical and Radiographic Abnormalities in 150 Workers Exposed to Non-Calcined Diatomaceous Earth in Central California	1202
<i>John Howard, et al.</i>	
Program to Prevent Asbestos-Induced Health Hazards in Finland—Asbestos Program in Finland	1204
<i>M.S. Huuskonen, et al.</i>	
Study on Haemolytic Activities of 10 Types of Coal Mine Dusts and Their Effect Factors	1206
<i>Xing Guo-Chang, et al.</i>	
High-Speed, High-Resolution X-ray Computed Tomographs in the Diagnosis of Pneumoconiosis	1211
<i>Hisao Shida, et al.</i>	
A Case Control Study of Pneumoconiotic Coal Miners in Brazil	1221
<i>Eduardo Algranti</i>	
Social and Economic Benefits of Prevention Measures at EW Fluorspar Mine {ABSTRACT}	1224
<i>Zhang Qifeng</i>	
Study on Protein Factor in Alveolar Macrophage of Experimental Silicosis	1225
<i>Zhang Qifeng, et al.</i>	
Respirable Dust Weight Concentration and Quartz Concentration in Respirable Dust Weight Concentration in Taeback and Kangneung Collieries	1229
<i>Cheon Yong-Hee, et al.</i>	
Coalworker's Pneumoconiosis and Respiratory Function in Chilean Miners	1234
<i>Rodrigo Benavides-Castellon</i>	
Studies on Preventive Effect of Aluminum Citrate on Silicosis	1237
<i>Zou Shiqu, et al.</i>	
Retrospective Mortality Study of Asbestoss Workers in Laiyuan	1242
<i>Zou Shiqu, et al.</i>	
Smoking and Radiologic Opacities in U.S. Navy Asbestos Workers {ABSTRACT}	1245
<i>A.M. Ducatman, et al.</i>	
The Disturbance of Breathing Mechanics in Rats after Intratracheal Instillation of Respirable Coal Mine Dusts {ABSTRACT}	1246
<i>J. Rosmanith, et al.</i>	
The Physical Characteristic of Dusts Applicated Intratracheally in Rats in Their Dispersed and Suspended State {ABSTRACT}	1247
<i>J. Rosmanith, et al.</i>	
Silicosis among Stone Mortar Workers in Northern Thailand, 1986	1248
<i>Orapun Metadilogkul, et al.</i>	
Silicosis among Workers in Refractory Brick Factory, Thailand	1251
<i>Orapun Metadilogkul, et al.</i>	
Progressive Massive Fibrosis and the Influence of Body Shape	1253
<i>Timothy J.L. Haley</i>	
Suggestions for Revision of the ILO Criteria for Asbestos Based on Screening 10,000 Workers	1261
<i>Kaye H. Kilburn, et al.</i>	
Pulmonary Functional Impairment from Years of Arc Welding	1264
<i>Kaye H. Kilburn, et al.</i>	

POSTER SESSION II

Coal Rank and Duration of Exposure as Determinants of Toxicity in Inhalation Experiments with Rats {ABSTRACT}	1269
<i>P. Sebastien, et al.</i>	
Aluminum-Induced Lung Disease {ABSTRACT}	1270
<i>P. De Vuyst, et al.</i>	
Planning a Dust Free Coal Mine	1271
<i>Roger F.J. Adam</i>	
Comparative Inhalation Hazards of Titanium Dioxide, Synthetic and Natural Graphite	1277
<i>Sandra A. Thomson, et al.</i>	
The Study on the Relationship Between Breath Dust Value (BDV) and Pneumoconiosis	1284
<i>Liu Zhanyuan, et al.</i>	
Problems of Labour Health on Preventing Dust Hazard in Township Industries	1288
<i>Liu Zhanyuan, et al.</i>	
Study of Fibrogenic Effect of Vermiculite Dust on Rat Lung	1290
<i>Liu Zhanyuan, et al.</i>	
Study on Dust Hazards and Preventive Measures in Modern Large Scale Petrochemical Enterprises	1293
<i>Liu Zhanyuan, et al.</i>	
Dust Arrester (DA) {ABSTRACT}	1295
<i>J.K. Sinha</i>	
Handling of Mineral Wool within the Construction Industry	1296
<i>Björn Lindblad, et al.</i>	
Mechanism of the Damage to AM by Silica and Anti-Cytotoxic Effects of Aluminum Citrate: Ultrastructural Study {ABSTRACT}	1297
<i>Hong Yin, et al.</i>	
Mini-Cyclones "TCR" in Nylon and in Aluminum: The Influence of Electrostatic Charges on the Efficiency of the Collecting of Respirable Dust {ABSTRACT}	1298
<i>G. Ripanucci</i>	
Study on Suppression of Soluble Aluminum Aerosols on Quartz-Induced Cytotoxicity—Combined Effects of Both Aerosols in an Artificial Dust Atmosphere	1299
<i>Chen Jin, et al.</i>	
Pseudo-Tumoral Lung Formations from Silica Free Dusts	1304
<i>Luciano Romeo, et al.</i>	
Mineral Fibers and Dusts in the Lungs of Subjects Living in an Urban Environment	1306
<i>F. Malchiodi Albedi, et al.</i>	
Prevalence of Pneumoconioses among Phosphate Rock Workers in Brazil	1310
<i>Eduardo Mello de Capitani</i>	
Size Characterization of Industrial Products (MMMF) Used in Buildings and Structures as Substitutes of Sprayed Asbestos-Containing Material	1312
<i>Corrado Ciccarelli</i>	
Silicosis in Pit Diggers in Serra Da Ibiapaba, Ceará, Brazil	1316
<i>Edson José de Barros Hatem, et al.</i>	
DNA Flow Cytometric Analysis of Mesothelial Cells Exposed <i>In Vivo</i> to Asbestos	1320
<i>Francis H.Y. Green, et al.</i>	
Alterations in Pulmonary Xenobiotic Metabolizing Enzyme Systems in Asbestotic Animals	1330
<i>Qamar Rahman, et al.</i>	
The Association of Small Irregular Opacities on Chest Radiograph with Aging in a Nonsmoking Population without Occupational Dust Exposure	1336
<i>Andrew J. Ghio, et al.</i>	
Pulmonary Effects of Acute Exposure to Sulfur Tetrafluoride During Electrical Cable Repair Work	1340
<i>Allen Kraut, et al.</i>	
Experimental Studies on the Effect on the Immune System of Exposure to Coalmine Dust and Quartz	1345
<i>Y. Kusaka, et al.</i>	
Bronchoalveolar Lavage in Subjects Exposed to Occupational Dusts	1351
<i>George Goodman, et al.</i>	
Exposures of Production Employees to Airborne Concentrations of Fibrous Glass During the Manufacturing Process	1354
<i>C.W. Axten, et al.</i>	
Measurement of Rounded Opacities in the Lung of X-ray Images Towards Quantitative Diagnosis of Pneumoconiosis	1358
<i>J. Toriwaki, et al.</i>	

CONTENTS (*continued*)

POSTER SESSION II (cont'd)

Cost Effectiveness of Pre-Employment Pulmonary Function Screening in New Hire for Electronic Assembly Line work	1364
<i>R. Than Myint, et al.</i>	
Utility of Quantitated Sputum Cytology to Detect the Effects of Exposure in Smokers and Nonsmokers	1368
<i>Tina J. Roby, et al.</i>	
Effect of Coal Dust on Mucin Production by the Rat Trachea {ABSTRACT}	1373
<i>V.P. Bhavanandan</i>	
Correlation Between Grade of Coal Workers' Pneumoconiosis at Autopsy with Antemortem X-ray Classification {ABSTRACT}	1374
<i>F.H.Y. Green, et al.</i>	

POSTER SESSION III

Effects of Platelet Activating Factor on Various Physiological Parameters of Neutrophils, Alveolar Macrophages, and Alveolar Type II Cells	1375
<i>Knox Van Dyke, et al.</i>	
Evaluation of the Fibrogenic Potential of Sandblasting Substitutes {ABSTRACT}	1380
<i>Y. Hammad, et al.</i>	
Studies of Silicosis among Migrant Workers (Report 2) Mortality among Migrant Workers for Tunnelling Works	1381
<i>Yuichi Yamada, et al.</i>	
Studies of Silicosis among Migrant Workers (Report 1) The Frequent Occurrence and Relevant Factors of Silicosis	1387
<i>Hideaki Nakagawa, et al.</i>	
A Case Study on Fiberglass Pneumoconiosis with Undifferentiated Cancer —Fiberglass, Cancerogenous Material	1395
<i>T. Sano</i>	
Ecologic Analysis of Coal Workers Pneumoconiosis Mortality in Illinois	1398
<i>Louise Wideroff, et al.</i>	
Death Certificate-Based Surveillance of Silicosis and Asbestosis in Illinois	1401
<i>Louise Wideroff, et al.</i>	
Gallium-67 Emission Tomography in Asbestosis {ABSTRACT}	1404
<i>E.M. Cordasco, et al.</i>	
Pulmonary Fibrosis Caused by Synthetic Textile Fibers?	1405
<i>Gunnar Hillerdal, et al.</i>	
The Distribution of Lymphocytes and Lymphocyte Phenotype Suggests Silico-Proteinosis Is Not a Systemic Disease {ABSTRACT}	1408
<i>D.E. Banks, et al.</i>	
Computed Radiography Utilizing Scanning Laser Stimulated Luminescence and Its Application for Classification of Pneumoconioses	1409
<i>Nobuyoshi Nakajima, et al.</i>	
Asbestos Disease in Commercial Roofers: Radiologic Signs	1414
<i>David C. Christiani, et al.</i>	
Possible Occupational Pulmonary Alveolar Proteinosis (PAP) {ABSTRACT}	1418
<i>S. Mandel, et al.</i>	
Subpleural Curvilinear Shadow in Interstitial Pulmonary Diseases	1419
<i>Hiroto Kasuga, et al.</i>	
DO Silicon-Oxygen Radicals Play a Role in the Quartz-Induced Hemolysis and Fibrogenicity?	1424
<i>Nar S. Dalal, et al.</i>	
Histocompatibility Antigens in a Population-Based Silicosis Series {ABSTRACT}	1429
<i>K. Kreiss, et al.</i>	
Hardrock Mining Exposures Affect Smokers and Nonsmokers Differently: Results of a Community Prevalence Study {ABSTRACT}	1430
<i>K. Kreiss, et al.</i>	
Blood Lymphocyte Response to Beryllium as a Workplace Screening Test for Subclinical Beryllium Disease {ABSTRACT}	1431
<i>K. Kreiss, et al.</i>	
Modified Nucleosides in Asbestos Insulation Workers at High Neoplastic Risk {ABSTRACT}	1432
<i>A. Fischbein, et al.</i>	

POSTER SESSION III (cont'd)

Chest Radiographic and Clinical Findings among Ironworkers and Millwright and Machinery Erectors {ABSTRACT}	1433
<i>A. Fischbein, et al.</i>	
Inter-Reader Variability among Readers Using ILO 1971 and 1980 Classifications of the Pneumoconioses	1434
<i>R.B. Althouse, et al.</i>	
Epidemiological Methods Designed to Assess Cross-Sectionally and Longitudinally the Respiratory Health of Workers Exposed to Ceramic Fibers {ABSTRACT}	1440
<i>J. Lockey, et al.</i>	
Malignant Pleural Mesothelioma in Monfalcone, Italy	1441
<i>C. Bianchi, et al.</i>	
Atmospheric PAH Concentrations During Chimney Sweeping {ABSTRACT}	1446
<i>U. Knecht, et al.</i>	
Role of Mast Cells in the Pathogenesis of Silicosis	1447
<i>Heidrun Behrendt, et al.</i>	
Autoimmunity Phenomena and Alterations of Humoral Immunological Responses in Silicotic Patients	1455
<i>H. Idel, et al.</i>	
Effect of Quartz Dust DQ 12 on Human Monocytes/Macrophages <i>In Vitro</i> —An Electron Microscopical Study ..	1459
<i>Heidrun Behrendt, et al.</i>	
Mediator(s) from Human Monocytes/Macrophages Induced by Quartz Dust DQ12 or Coal Mine Dust TF-1 Are Leading to Release of Oxygen Radicals from Human Granulocytes	1466
<i>E. Maly, et al.</i>	
Cytotoxicity and Spectroscopic Investigations of Organic Free Radicals in Fresh and Stale Coal Dust	1470
<i>N.S. Dalal, et al.</i>	
Evidence for Free Radical Involvement in the Toxicity and Carcinogenicity of Chromate Dusts	1478
<i>Xianglin Shi, et al.</i>	

POSTER SESSION IV

The Single Breath Diffusing Capacity Measurement as a Predictor of Exercise Induced Oxygen Desaturation in Patients with Silicosis	1481
<i>K. Ratkalkar, et al.</i>	
The Relationship Between Asbestos Bodies, Serum Immuno-Globulin Levels and X-ray Changes in Asbestos Workers	1485
<i>V. Cvetanov, et al.</i>	
Changes in Lung Function in Coal-Miners With and Without CWP {ABSTRACT}	1487
<i>S. Kovács, et al.</i>	
Effect of Alveolar Lining Material on Particle Binding and Phagocytosis {ABSTRACT}	1488
<i>M.F. Khan, et al.</i>	
Toxicity Risks from Bacterial Endotoxin Inhalation	1489
<i>Robert Burrell, et al.</i>	
Description of Medical Services Rendered at the Chrisotila Asbestos Mine, with 1100 Employees, in the State of Goiás, Brazil {ABSTRACT}	1494
<i>A.S. Nunes, et al.</i>	
High-Resolution Computed Tomography of Pneumoconiosis	1495
<i>Masamitsu Kido, et al.</i>	
Asbestos-Associated Rounded Atelectasis in a Cohort of Insulation Workers	1505
<i>Alfred Franzblau, et al.</i>	
Cancer Mortality among Silicotic Cases	1509
<i>G.F. Rubino, et al.</i>	
Alveolitis in Occupational Lung Diseases (Old)	1514
<i>A. Teles de Araújo, et al.</i>	
New Dustgravimeter for Up-to-Date Examination of Dust Conditions at Mining Working Places {ABSTRACT}	1519
<i>H. Vekény</i>	
Measures for the Improvement of the Means and Methods of Dust Control and the Prevention of Pneumoconiosis in the Coal Industry {ABSTRACT}	1520
<i>A.F. Belousov Aucctu</i>	
Unexpected Sarcoidosis Following Pneumoconiosis—Clinical Observations {ABSTRACT}	1521
<i>S. Binaschi, et al.</i>	
Asbestos Exposure among Finnish Mesothelioma Patients	1522
<i>A. Tossavainen, et al.</i>	

CONTENTS (continued)

POSTER SESSION IV (cont'd)

Factors that May Influence Interactions Between Mineral Dusts and Lung Cells {ABSTRACT}	1524
<i>G.L. Bartlett, et al.</i>	
Electron Microscopic Findings of Hypersensitivity Pneumonitis {ABSTRACT}	1525
<i>K. Reijula, et al.</i>	
Muscularization of Pulmonary Arteries in Coal Workers Pneumoconiosis	1526
<i>Siang-Nian Hu, et al.</i>	
Study of Silicosis in the Industrial Disease Hospital (ESI Hospital) Madras	1535
<i>A. Durairaj</i>	
On the Blastomogenic Capability of Submicroscopic Asbestos Dust: Is Its Fibrous Structure the Only Physical Property Determining Its Blast Potential? {ABSTRACT}	1537
<i>K. Kolev</i>	
Influence of Chemical/Thermal Pretreatment on the Cytotoxicity of Coalmine Dusts	1538
<i>F. Tilkes, et al.</i>	
Quantification of Anthracosilicotic Granulomas in Lungs and Lymph Nodes of Rats {ABSTRACT}	1542
<i>J. Bruch, et al.</i>	
Respiratory Morbidity in Agate Workers {ABSTRACT}	1543
<i>S.H. Clerk</i>	
Air Pollution Investigations in Some Plants for Preliminary Processing of Vegetable Fibres (Cotton and Hemp) —Airborne Dust and Mycotoxicological Contamination {ABSTRACT}	1544
<i>St. Ivanova-Djoubrilova, et al.</i>	
Impairments in Functional Subsets of T-Suppressor (CD8) Lymphocytes, Monocytes, and Natural Killer Cells among Asbestos-Exposed Workers {ABSTRACT}	1545
<i>J.G. Bekesi, et al.</i>	
On the Use of Light Microscopy for the Recognition, Evaluation and Control of Respiratory Disease {ABSTRACT}	1546
<i>J. Jankovic, et al.</i>	
Design and Calibration of a Multi-Purpose Aerosol Sampler {ABSTRACT}	1547
<i>W. Jones, et al.</i>	
Computerized Tomography (CT) in Coal Workers' Pnuemoconiosis	1548
<i>Pan Jishu, et al.</i>	
Experiencia en el Uso de la Clasificación Internacional de Neumoconiosis Oit (1980) en 40 Centros Mineros del Peru {ABSTRACT}	1551
<i>Francisco K. Tukiuda</i>	
Inorganic Particles in Coal Miners' Lungs {ABSTRACT}	1552
<i>L.E. Stettler, et al.</i>	
Characteristics of Lung-Retained Coal Dusts Related to Morphological and Clinical Findings	1553
<i>M. Dobрева, et al.</i>	
Prevalence of Pneumoconiosis in Zimbabwe's Coal and Hard Rock Mines {ABSTRACT}	1556
<i>R.S. Baloyi, et al.</i>	
Pulmonary Mica Dust Lesions {ABSTRACT}	1557
<i>S.H. Zaidi, et al.</i>	
Main Measures for Controlling Coal Dust in Place at the Longwall Shearers in China {ABSTRACT}	1558
<i>Chai Zao-Ci</i>	
The Pneumoconiosis Control in China	1559
<i>Lin Xiao Ning</i>	
Dose-Response Relationship Between Asbestos Exposure and Incidence of Asbestosis	1560
<i>Huilan Zhu, et al.</i>	
The Correlation Between Silicosis and Lung Cancer—Pathological Evidences from 5 Autopsied Cases	1563
<i>Yu Tong</i>	
Behavioral Toxicity in Silicotic Patients (Pilot Study)	1573
<i>Fengsheng Song, et al.</i>	

EPIDEMIOLOGY—FIBERS

Similarities in Lung Cancer and Respiratory Disease Mortality of Vermont and New York State Talc Workers ..	1576
<i>S.H. Lamm, et al.</i>	

SCIENTIFIC PAPERS

BIOLOGICAL EFFECTS OF SHORT FIBERS

J.C. WAGNER

MRC External Staff Team on Occupational Lung Diseases, Llandough Hospital, Penarth, South Glamorgan, South Wales

Evidence implicating fibre diameter in the development of mesotheliomas and pulmonary fibrosis is now generally accepted but the contribution that the length of mineral fibres makes is not so well established. As the difference in length of fibres found in the urban situation, and that in the occupational and para-occupational environments is revealed, so the importance of length may increase. Our investigations, reported here, confirm the concept that fibre length is a significant factor in the development of these asbestos related diseases.

Timbrell¹ illustrated that the maximum diameter of a fibre that could be inhaled into the parenchyma of the lung was 3.0 μm . This has subsequently been confirmed in both man and experimental animal, although fibres above 2.0 μm diameter are uncommon. The length/diameter characteristics were clearly defined by the experimental studies of Stanton,² Pott,³ and Wagner⁴ et al. These investigations confirmed that fibres of 0.25 μm in diameter and about 8 μm in length were associated with mesotheliomas, whereas the coarser fibres of between 1.0–3.0 μm in diameter and of 8 μm in length were probably responsible for pulmonary fibrosis.

Our investigations on tremolite exposure in both men and experimental animals⁵ have contributed to clarification of the different fibre diameter associated with these different lesions. However, our statement that the shorter fibres physical forms are relatively innocuous was challenged with the request to define "relative." It was hoped that our experiments with Oregon erionite would satisfy the critics.⁶ In these studies we showed that the relatively long erionite fibre produced a 100% incidence of mesotheliomas following exposures, both by intrapleural and inhalation exposures compared with no tumours being produced when a non-fibrous synthetic erionite was used. This established that the mineral fibres and not the chemical constituents were responsible for the lesions. The critics pointed out that the control material was non-fibrous and that we had not proved that short fibres within the experimental material were relatively innocuous. Therefore, to answer their queries we would have to produce dust samples of long and short fibre in sufficient quantities for both implantation and inhalation studies. In our investigations in order to produce both tumours and fibrosis by inhalation, the exposure must last twelve months and needs 2 kilograms of dust. Hitherto production of asbestos fibre of specific length has not been successful and milling crocidolite has usually resulted in the short fibre being reduced to non-fibrous particles. Alternatively, in an attempt to produce crocidolite <5.0 in length, for an intrapleural study, it was found that there were no long

fibres seen in the pre-inoculation dust, but there were long fibres retained in the granulomas⁷ (thus illustrating our theory about the selective retention of fibre).

We decided to use Oregon erionite⁶ because of its friable nature and Mr. J.W. Skidmore was successful in producing sufficient quantities by precise milling over a very short time. A similar preparation was made with UICC crocidolite. Final assessments of the success of milling could only be made on fibre measurements at the end of the experiment, on the lungs from the inhalation study, and pleural granuloma from the implantation investigation. The other two samples used were the longer erionite as prepared for the original experiment, and standard UICC crocidolite for long crocidolite. It was accepted that these were mixed length samples, with sufficient long fibre to produce lesions. The dust for the short fibre was prepared by disc milling. By making empirical decisions, only fibres <5 microns in length were found using the following strategy of 10 sessions each of 10 seconds duration, the mill being opened after each session and the dust redistributed. The inhalation⁸ and intrapleural⁹ methods have previously been described, as have the characterisation of the dust clouds and the respirable inoculated materials. The animals used were SPF Fischer F344 rats (caesarian derived, barrier maintained, and free from disease as shown by random culling). Eighty rats of each sex for the inhalation study and 64 of each sex for intrapleural inoculation, were randomly allocated, in equal numbers, to the 4 treatment groups. Post mortem and histological examination were carried out.¹⁰ The fibrosis grading¹¹ is standardised on an internationally accepted scale: Grade 1 normal; 2 dust in macrophages; 3 early interstitial reaction; 4 first signs of fibrosis; 5, 6, 7 increasing degrees of fibrosis; 8 severe fibrosis. The only other lesions noted were 1 Bronchiolar hyperplasia; 2 mesothelioma. Finally, characterisation of the fibres was carried out; recovery methods were used on a known weight of lung tissue from the inhalation; and tissue from the granuloma from the intrapleural experiment.

RESULT

Dust Studies

Measurements were carried out on the four dusts recovered after 24 months, i.e. exposure period of 12 months and a further survival time of 12 months. Our findings substantiated the previous experimental results on the retention of the longer fibres after inhalation. It also demonstrated our success in the production of fibres in the size ranges required. Figure 1 and

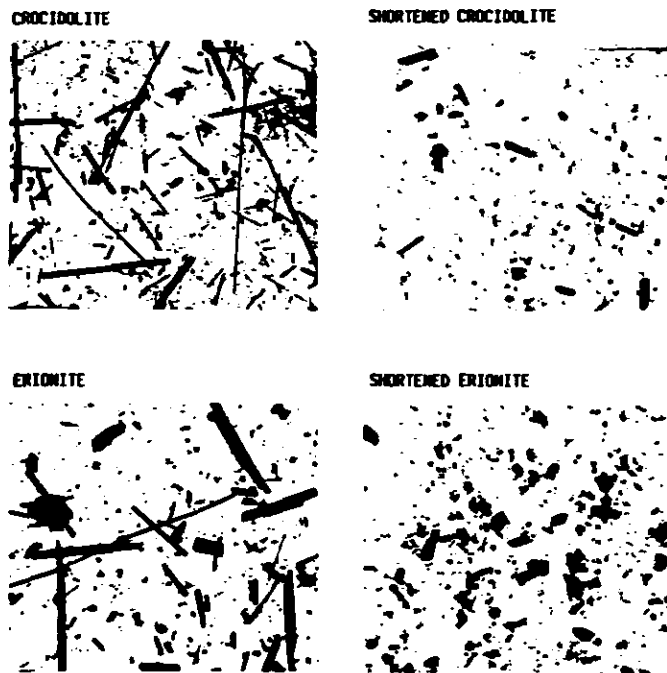

Figure 1. Fibre recovered from rat lung after 24 months.

Tables I and II show the fibre recovered from the lungs of animals after a period of 24 months. It can be seen from the electron micrographs taken of the shortened material the complete absence of any fibres with lengths greater than 5 microns.

DISCUSSION

We were endeavouring to answer two questions:—

1. Is it possible to show by animal experimentation that below a minimum length, fibre of standard diameter does not produce mesotheliomata of significant pulmonary fibrosis, whereas longer fibre of similar type are capable of their production?
2. What is the critical length of fibre?

Minimum Length (1)

We have succeeded in answering the first point, but have not been able to define the critical length of fibre as required in (2).

In the intrapleural inoculation study we were able to produce over 90% of tumours in the animals exposed to either of the long fibre dusts. Using the short fibre a single mesothelioma was produced with the crocidolite sample, no tumours occurred in the animals exposed to the erionite.

The inhalation experiment produced the expected tumour incidence of over 90% of the animals, exposed to the erionite, which had survived for a sufficient time period to develop

mesotheliomas. It must be remembered that there had been a serial killing of animals at an earlier stage for the inhalation study which substantially reduced the number surviving for more than one year. The long crocidolite only produced a single tumour. This confirmed the importance of using the Oregon erionite material, as the crocidolite produced too few tumours for comparison with the short fibre results. No tumours occurred in the animals exposed to either of the short fibres.

The inhalation studies demonstrate that in the animals exposed to the long fibres minimal fibrosis occurs, whereas the short fibres only produce a tissue reaction.

Critical Length (2)

Production of fibre below 5 microns and to include a sufficient number of fibres in the 3–5 micron range proved to be extremely difficult. This is because a decrease in the milling time led to the appearance of fibres greater than 5 microns in length. The result of this difficulty was that the majority of the fibre used in the short samples was below 3 microns whilst still retaining the fibrous nature of the material. This was also apparent in the material recovered from the lungs of the animals. Very occasional longer fibre was found in the short crocidolite. This could account for the single mesothelioma seen in an animal exposed to this dust. These results proved that the milling was successful. In a previous experiment with milled dusts a large number of mesotheliomas were induced.⁷ This was thought to be due to a long fibre component

Pathology

Intrapleural Inoculation

Dust	Mesothelioma	Non-mesothelioma
UICC Crocidolite	24	8
Shortened Crocidolite	1	31
Erionite	30	2
Shortened Erionite	0	32

Inhalation

	Fibrosis Gradings 4 rats/sacrifice				Tumours		Total Excl. Sacrif.
	3	6	12	24	Meso.	BAH	
	mths.	mths.	mths.	mths.			
UICC Crocidolite	2.9	3.0	4.1	3.9	1	2	24
Shortened Crocidolite	2.0	2.0	3.3	2.8	0	0	24
Erionite	2.4	3.0	4.0	4.0*	24	2*	27
Shortened Erionite	2.9	3.0	3.0	3.1	0	1	24

* 1 animal only remained for sacrifice

* 2 bronchiolar alveolar hyperplasia with mesotheliomas

remaining in the dust.

As in previous investigations, the animals treated with the long fibre dusts tended to selectively retain the longer fibres. In the inhalation study, it was of importance to see how little long erionite was retained in the lungs of the animals, as others with this exposure developed the tumours.

Attempts should be made to produce a more satisfactory short

erionite sample closer to 5.0 microns in length. All investigations have failed to produce a satisfactory sample from amphibole asbestos. It is possible that by using more complex methods a small sample sufficient for the implantation study could be produced. When this was done using glass-micro fibre the cost of production was extremely high, and no attempt was made to produce a larger sample of inhalation experiments.

Table I
Inhalation Experiment
Percentage and Number of Fibres in Defined Categories
per Gram of Dried Lung Tissue ($\times 10^6$)

	Fibre Size (μm)		3 months	6 months	12 months	24 months
	L.	D.				
SHORT	3 - 5	< 0.5	0.3 %	1.2 %	0.6 %	1.0 %
			7.0 *	42.6 *	47.9 *	63.0 *
CROCIDOLITE	> 1	< 0.5	10.3 %	29.1 %	15.3 %	15.1 %
			231.3 *	1033.1 *	1221.6 *	948.6 *
LONG	> 6	< 0.5	1.6 %	2.8 %	3.2 %	5.8 %
			425.5 *	991.7 *	1427.1 *	2529.3 *
CROCIDOLITE	3 - 6	< 0.5	3.0 %	4.8 %	5.2 %	8.4 %
			797.9 *	1712.9 *	2319.0 *	3663.1 *

* No. of fibres

REFERENCES

1. Timbrell, V.: The Inhalation of Fibrous Dusts. *Ann. NY Acad. Sci.* 132:255-273 (1965).
2. Stanton, M.F., Layard, M., Tegeris, A., Miller, E., May, M., Morgan, E., Smith, A.: Relation of Particle Dimension to Carcinogenicity in Amphibole Asbestoses and other Fibrous Minerals. *J. Natl. Cancer Inst.* 67:965-975 (1981).
3. Pott, F.: Some Aspects on the Dosimetry of the Carcinogenic Potency of Asbestos and other Fibrous Dusts. *Staub-Reinhalt. Luft* 38 (12):486-490 (1978).
4. Wagner, J.C., Berry, G., Hill, R.J., Munday, D.E., Skidmore, J.W.: Animal Experiments with MMM(V)F Fibres—Effects of Inhalation and Intrapleural Inoculation in Rats. *WHO/IARC Biological effects of man-made mineral fibres*. Proceedings of WHO/IARC Conference, Copenhagen, 20-22 April 1982. pp 209-233 (1984).
5. Wagner, J.C., Chamberlain, M., Brown, R.C., Berry, G., Pooley, F.D., Davies, R., Griffiths, D.M.: Biological Effects of Tremolite. *Br. J. Cancer* 45:352-360 (1982).
6. Wagner, J.C., Skidmore, J.W., Hill, R.J., Griffiths, D.M.: Erionite Exposure and Mesotheliomas in Rats. *Br. J. Cancer* 51:727-730 (1985).
7. Wagner, J.C., Griffiths, D.M., Hill, R.J.: The Effect of Fibre Size on the In Vivo Activity of UICC Crocidolite. *Br. J. Cancer* 49:453-458 (1984).
8. Wagner, J.C., Berry, G., Skidmore, J.W., Timbrell, V.: The Effects of the Inhalation of Asbestos in Rats. *Br. J. Cancer* 29:252-269 (1974).
9. Wagner, J.C., Berry, G.: Mesotheliomas in Rats following Inoculation with Asbestos. *Br. J. Cancer* 23:567-581 (1969).
10. McConnell, E.E., Wagner, J.C., Skidmore, J.W., Moore, J.A.: A Comparative Study of the Fibrogenic and Carcinogenic Effects of UICC Canadian Chrysotile B Asbestos and Glass Microfibre (JM100). *WHO/IARC Biological effects of man-made mineral fibres*. Proceedings of WHO/IARC Conference, Copenhagen, 20-22 April 1982. pp 234-252 (1984).

Table II
 Inhalation Experiment
 Percentage and Number of Fibres in Defined Categories
 per Gram of Dried Lung Tissue ($\times 10^6$)

	Fibre Size (μm)		3 months	6 months	12 months	24 months
	L.	D.				
SHORT	3 - 5	< 0.5	1.0 %	1.7 %	0.3 %	0.6 %
			2.4 *	8.5 *	9.1 *	6.3 *
ERIONITE	> 1	< 0.5	32.0 %	37.2 %	37.9 %	39.7 %
			77.1 *	186.0 *	1154.4 *	449.3 *
LONG	> 6	< 0.5	7.0 %	5.8 %	5.0 %	7.0 %
			130.0 *	350.9 *	419.1 *	350.8 *
ERIONITE	3 - 6	< 0.5	15.5 %	16.3 %	17.0 %	15.3 %
			287.9 *	991.6 *	1424.8 *	764.3 *

* No. of fibres

EXPERIMENTAL STUDY OF FIBROSIS EFFECT OF POLYPROPYLENE AND POLYETHYLENE DUST ON RAT LUNGS

LIU ZHUAYUAN • Fang Yuxiang • Yie Fengting • Xiao Chunyuan

Liaoning Institute of Labour Hygiene, P.R. China

Polypropylene and polyethylene are all high molecular compounds and typical synthetic organic substances. To research the fibrosis effect of the dust of these two organic substances, experiments have been respectively carried out on animal—the rat. 500 mg of dust was respectively injected intratracheally into each of 134 rats (half male and half female), and observations were carried out for 18 months. The results of the experiment showed that the main change of pathological histology in the early period was the granulomatosis foci caused by the dust (the polyethylene dust group showed foreign body multinuclear giant cell granuloma) and the hyperplasia of reticular fibres. 18 months after dust injection both experimental groups were found to show pronounced hyperplasia of reticular fibres inside the foci and around the bronchi and presence of collagen fibres. The content of collagen protein in the whole lungs is higher than the physiological saline control group. Therefore, the authors consider that the dust of polypropylene and polyethylene has a light fibrosis effect on the rat lungs.

INTRODUCTION

Polypropylene and polyethylene are petroleum chemical products which are high molecular compounds obtained by polymerization of propylene and ethylene. They are solid powder in milky colour without poison and odor, insoluble in water at normal temperature, acid and corrosion resistant and good in insulation. Along with their wide use and rapid increase of output, more and more workers have the chance to be in contact with the two kinds of dust in production. The report has not yet been witnessed as to whether the dust of polypropylene and that of polyethylene can cause fibrosis. In order to study the fibrosis effect of polypropylene and polyethylene dust, experiments have been made on the animal and the results are as follows.

METHOD OF EXPERIMENT

1. Preparation of dust: The fresh dust is obtained from the workshop producing polypropylene and polyethylene from a chemical fibre company. In the dust no quartz was detected by an X-ray diffractometer, and the dust was classified by a Barkhausen-Kurtz type centrifugal classifier so that 80% of the dust was of the grain size under 5 microns. The dust was then sterilized by ultraviolet rays for 2 hours. Quartz dust for control was provided by the Labour Hygiene and Occupational Disease Research Institute under the Chinese Academy of Preventive medicine.

2. Animal selection and grouping: 134 wister rats were selected and divided at random into 4 groups (polyethylene group, polypropylene group, quartz control group and physiological saline control group).
3. Dust injection into the animal: 50 mg of physiological saline suspension solution, with a small amount of tween added, was injected at a time intratracheally. Then observations were carried out in turn respectively 1, 6, 12 and 18 months after dust injection. The animal was killed with the head cut off after slight anesthesia. The right lung was kept for collagen quantitative analysis. The left lung and hilus lymphonodi, after fixation, paraffin embedding, sectioning and staining with HE, Foot and VG, was subject to observation for histopathology.

RESULTS OF EXPERIMENT

Visible by the Naked Eye

1. Quartz group: 1 month after dust injection the hilus lymphonodi were as big as a soya bean or a broad bean. The surface of the lungs were found smooth. On partial lungs of most cases were found to have milk-white sections of different area, of which the surface was full of bumps and holes and felt hard as to have sand grains. 6, 12 and 18 months after dust injection, the above changes gradually became greater.
2. Physiological saline group: During the experiment, the hilus lymphonodi were all as big as a rice grain. The surface of the lung tissues were found smooth, soft and elastic.
3. Polypropylene and polyethylene groups: 1 and 6 months after the injection of dust, the hilus lymphonodi of both groups were of rice size. The lung tissues were soft and elastic. 12 and 18 months after dust injection, the lung tissues were still soft and elastic. Some cases showed local ecchymoma and emphysema.

Visible Under Microscope

1. Quartz group: 1 month after dust injection, the hilus lymphonodi and lung tissues were found to have 4th grade fibrous tubercula around which there were slight emphysema. 6, 12 and 18 months after dust injection, all cases showed fibrous tubercula.
2. Physiological saline group: Throughout the experiment

no dust reaction was found.

3. Polypropylene and polyethylene groups: 1 month after dust injection, the hilus lymphonodi of neither group showed coniosis cell foci. Inside the lung tissues there were cell foci of different shape and size which consists of macrophages, epithelioid cells, coniosis cells and a great amount of dust particles. The polyethylene group showed that there were divergent Langhans' or foreign body giant cells in the cell foci. In the foci slight hyperplasia of reticular fibres were found. On some of the air sacs the epithelioid cells got swollen. Some of the bronchi showed hyperplasia or disappearance of epithelioid cells. 6 months after dust injection, all hilus lymphonodi were found to have a small amount of coniosis cell foci and translucent dust particles, on the surface of which there was a brown coloured layer. Inside the lung tissues there were still visible cell foci of different sizes and in the foci there are still macrophages, coniosis cells and dust particles with a brown coloured layer on the surface of the particles. Hyperplasia of reticular fibres were visible in the foci. 12 months after dust injection both groups showed foci consisting of cells as those 6 months after dust injection. But the number of foci decreased whereas the foci became bigger with clear boundaries. The polyethylene group was still found to have foreign body multinuclear giant cells. Inside the foci and in between the foci there were hyperplasia of reticular fibres. In some of them fine collagen fibres were visible. In some of the foci, pronounced hyperplasia of reticular fibres were found in between the air sacs as well as around the bronchi and around blood vessels, and collagen fibres were also visible. Bronchi of various sections got seriously harmed.

The analytical results of the collagen protein content in the whole lungs are given in Table I and Figure 1.

DISCUSSION

Polypropylene and polyethylene are all synthetic organic substances without free silicon dioxide. Different views exist as to the research of fibrosis effect of synthetic organic dust. The present experiment on the dust injected animal, through observation 1 to 18 months intervals, showed that polyethylene and polypropylene dust may cause slight hyperplasia of fibre tissues of lungs. The hyperplasia of fibre tissues is more obvious in the lung mesenchyme and around the bronchi. The tissular structure of the lungs were obviously damaged but no typical experimental nodular change was found.

The two experimental groups, polyethylene and polypropylene, showed similar pathological features and course of affection. At the early period of dust injection (1~6 months), a considerable number of granuloma changes were irregular in shape and different in size. The granulomas were rich in cells and were generally found around terminal or respiratory bronchioles. Some of the granulomas leaned against the bronchi walls. The harmed bronchi showed epitheliosis. There were secretions in the cavities and inflammatory infiltration around them. 12 to 18 months after dust injection, granuloma foci decreased. Pronounced hyperplasia of reticular fibres inside the foci and around the bronchi. Some leaned against the bronchi walls with collagen fibres inside. Normal structure of air sacs around the foci disappeared.

There were, however, slight differences between the two groups. In the granuloma foci of the polyethylene group there were divergent Langhans' or foreign body multinuclear giant cells. But in the polypropylene group such cells could hardly be seen. The cause remains to be studied.

The analysis of collagen protein content in the whole lungs tallied with the features of pathological changes.

Table I
Analytical Results of Collage Protein Content
in Whole Lungs (mg)

Period of observation (month)	1		6		12		18	
	$\bar{N}\bar{X} + SD$	$\bar{N}\bar{X} + SD$	$\bar{N}\bar{X} + SD$	$\bar{N}\bar{X} + SD$	$\bar{N}\bar{X} + SD$	$\bar{N}\bar{X} + SD$	$\bar{N}\bar{X} + SD$	
Polyethylene group	9 41.1 ± 5.8	9 37.5 ± 7.9	24 68.5 ± 17.5	8 91.6 ± 21.5				
Polypropylene group	8 48.9 ± 18.2	8 44.9 ± 8.0	21 101.6 ± 28.0	4 62.2 ± 8.3				
Quartz group	5 57.9 ± 15.0	8 97.8 ± 63.0	10 110.5 ± 64.6	6 94.8 ± 51.8				
Physiological saline group	7 33.4 ± 4.5	9 24.3 ± 6.5	23 46.4 ± 11.0	11 46.4 ± 10.6				

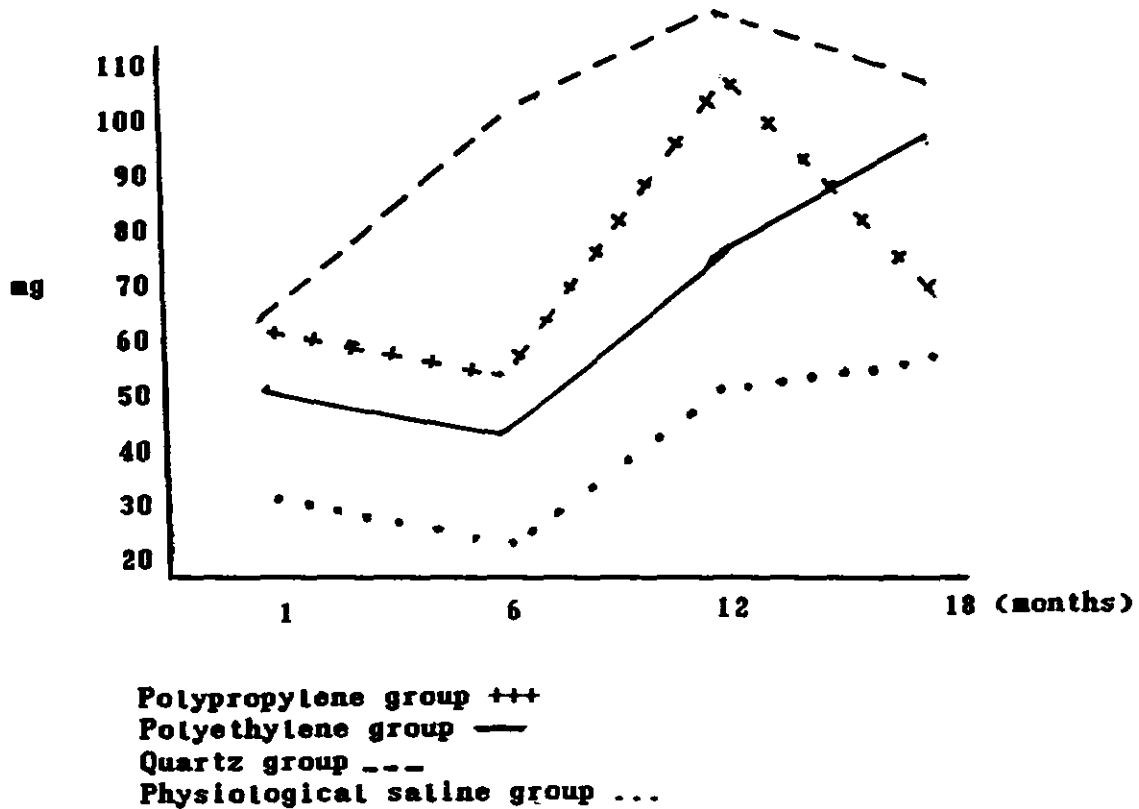

Figure 1. Variation curve of collagen protein content in the whole lungs.

SUMMARY

By unexposed injection intratracheally of 50 mg of dust at a time and through 1~18 months histopathological observation and analysis for collagen protein content of whole lungs, we consider according to the experimental results that the dust of polyethylene and polypropylene dust has a slight fibrosis effect on rats. In the earlier period (1~6 months) after dust injection the effect is mainly manifested in the form of granuloma changes, whereas in the later period (12~18 months) after dust injection the lung tissues mainly show granuloma changes and hyperplasia of interstitial fibre tissues of the lungs.

REFERENCES

1. Liang Shurong: Pneumoconiosis Pathological Atlas, p. 39, 1981, People's Hygiene Publishing House.
2. Zhen Hongquan: Study of Fibrosis Effect of Viscose Fibre, p. 29, 1987, China Medical College: Study of Organic Pneumoconiosis.
3. Zhen Hongquan: PVC Plastic Pneumoconiosis and Experimental Study, p. 16, 1987, China Medical College: Study of Organic Pneumoconiosis.

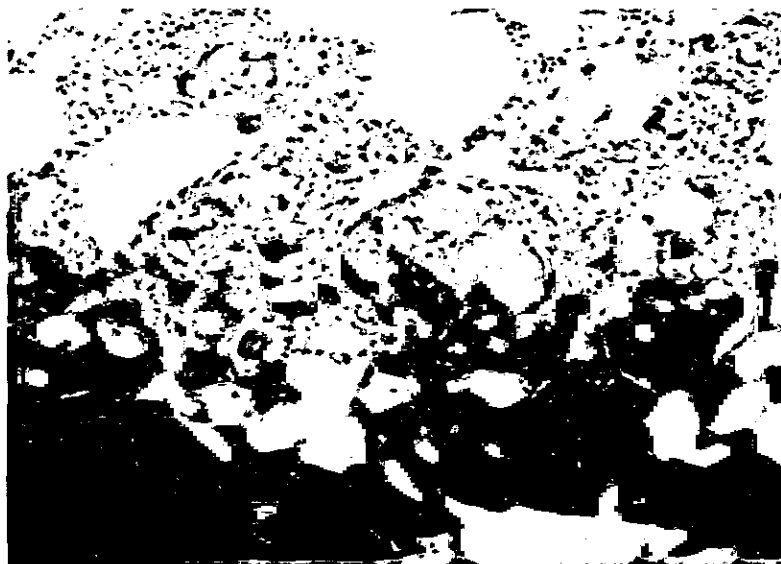

Polyethylene (One month) 34578 HE 6,7*10

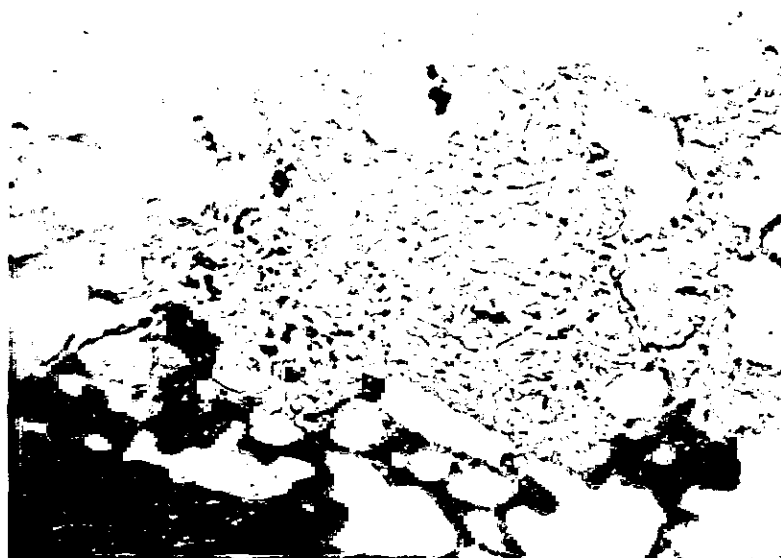

Polyethylene (Six months) 35678 Foot 6,7*10

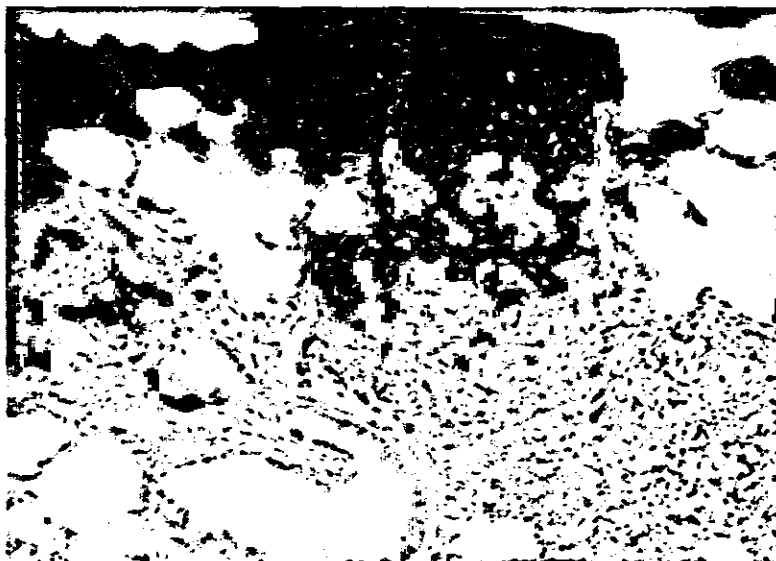

Polyethylene (One month) 34679 HE 6,7*10

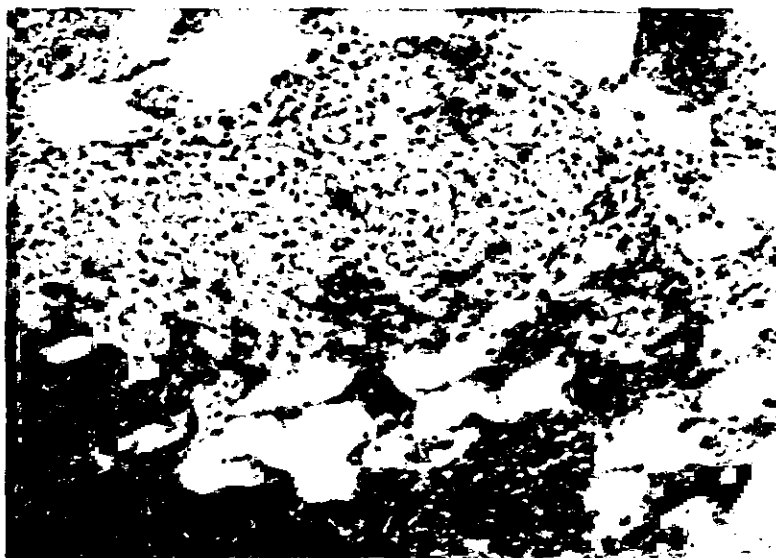

Polyethylene (Twelve months) 3467 HE 6,7*10

APICAL PLEUROPULMONARY CHANGES IN PERSONS EXPOSED TO ASBESTOS—EXPERIENCE FROM 40 PATIENTS

GUNNAR HILLERDAL, M.D.

Department of Lung Medicine, Uppsala University, Akademiska Sjukhuset, S-751 85 Uppsala, Sweden

INTRODUCTION

Parenchymal changes due to asbestos exposure are classically situated in the lower lobes. Pleural plaques and diffuse pleural thickening are also found mainly in the lower or the mid zones of the lungs. However, there have also been reports on asbestos exposure leading to upper lobe changes.¹⁻³

MATERIAL AND METHODS

Inclusion criteria and patients. Up to the end of 1986, about 1,600 patients with bilateral pleural and/or parenchymal changes due to exposure to asbestos on chest roentgenogram had been collected at the Department of Lung Medicine of Uppsala University. Among these 1,600 patients, there were 40 who showed an apical pleural thickening at least 5 mm thick on one side or both.

All patients have been followed until the end of 1987.

The mean age at the first sign of apical affection was 60 years; the youngest was 31 years old and the oldest 78 years. The mean latency time from the first exposure to the development of apical changes was 32 years, with a minimum of 5 years and a maximum of 51 years. Twenty-one patients showed apical changes only on the right side, four on the left side only and 15 on both sides. In all patients observed for more than five years there was an obvious progression of the apical lesions.

In five patients, CT was performed. In those patients it was seen that the lesions were mainly pleural but were causing compression of the lung parenchyma, and that some fibrous strands were reaching into the lung from the thickened pleura.

All patients had other asbestos-related pleural changes in the lungs on both sides, bilateral changes being a prerequisite for inclusion to the group in the first place. There was usually thickening around the whole lung, with a marked increase apically. In five patients a benign asbestos pleural effusion had been diagnosed before the apical lesions became evident.

In eight patients bronchoscopy was performed and culture for tuberculosis was negative. Five patients had a course of tuberculosis treatment because of a positive tuberculin test and suspicion of tuberculosis based on the radiological findings. This treatment did not affect the progression of the disease. A tuberculin test was performed in 25 patients and was negative in 12 of them, but in the rest it was positive, sometimes strongly so, the strongest reactor being 30 mm (2 tuberculin units).

Complete lung function test results were available in 21 patients. The vital capacity was affected in all cases. On an average it was reduced to 62 percent of the predicted. The total lung capacity was also decreased in all patients and in the mean 68 percent remained of the predicted value.

Upper lobe changes are a fairly rare manifestation of exposure to asbestos as judged from the paucity of reports in the literature.¹⁻³ There are a number of diseases which manifest themselves at the pulmonary apices. An unspecific fibrotic reaction is common in elderly persons but never reaches the sizes observed in the patients presented here. Many of these patients would previously have been diagnosed as suffering from tuberculosis. It is important to be aware of this manifestation of asbestos, mainly for clinical reasons, to avoid confusion with tuberculosis, but also for compensation purposes.

How specific is this type of lesion for exposure to asbestos? Our experience indicates that similar reactions are very rare in persons who are not exposed to asbestos. As mentioned, there are other diseases which can cause lesions of the upper lobe, but the typical primary thickening of the pleura with compression secondarily of the lung parenchyma is not seen with other diseases or is at least very rare. The lung department is the only one in the county and any lung changes of this type would very likely be referred to us for evaluation. They would also have been discovered at the general health survey, which was in practice in the county until fairly recently. Thus, the lesion seems to be as pathognomonic to asbestos as are pleural plaques.

Why does this lesion occur in some patients and not in others? It does not seem to be due to the degree of exposure. This seems to depend on individual factors, and my personal belief is that some disturbance of the immune system caused by asbestos is responsible for it.

Apical pleural thickening due to exposure to asbestos is usually only a part of a general reaction, and other parts of the same lung and usually also the other lung are also involved. The tendency to progression will, with time, in many patients cause a serious deterioration of lung function. The patients should be followed with chest roentgenogram and lung function regularly.

REFERENCES

1. Desbordes, J., Tayot, T., Duwoos, H., Ernoult, J.L., Mancuvrier, L., Rousselin, L., Thoreux, P., Veret, J., Pingard, R., Bezannier, R.: Aspects actuels de l'asbestose professionnelle. *Rev. Tub. Pneumol.* 36: 1203-1222 (1972).
2. Green, R.A., Dimcheff, D.G.: Massive bilateral upper lobe fibrosis secondary to asbestos exposure. *Chest* 65:52-55 (1974).
3. Hillerdal, G.: Asbestos exposure and upper lobe involvement. *Am. J. Roentgenol.* 139:1163-1166 (1982).

RADIOGRAPHICAL APPEARANCE OF TALCOSIS AND COMPOSITION OF TALC

ZHAO JINDUO • Li Zhong* • Liu Jingde* • Du Yuan† • Wang Rechen†

*Shenyang Research Institute of Industrial Hygiene and Occupational Diseases

†Liaoning Institute of Industrial Hygiene, P.R. China

The workers exposed to talc dust are increasing in number in textile, paper-making, glass-processing, ceramics, cosmetics, rubber and pharmaceutical industries, as well as paint, milling and carving of talc and so on. We investigated the concentration of the dust in the workshops in a mine and mill, and made a mineralogical examination. The chest X-ray films of the workers exposed to talc dust have been observed. The data are summarized and reported as follows.

INDUSTRIAL HYGIENE

This talc mine is a company of the mine and mill with an exploiting history of over 60 years. In the 50s and 60s, the dust concentration in the workplace of the mine ranged 68-582 mg/m³ and the dust concentration in the mill ranged 208-5561 mg/m³, and in talc carving factory, the dust concentration was several hundred mg/m³.

The dust concentration in the workshop was reduced in the 70s, but it still ranged 50-395 mg/m³. Over fifty percent of the particles were less than 5 μ in diameter; free silica dust ranged 0.75-2.87%.

MINERALOGICAL EXAMINATION OF THE TALC

The talc is pure, mineralogically, the ore is pure talc, the impurities are a little serpentine (H₄Mg₃SiO₂O₉) and phosphorite, little quartz, without tremolite Ca₂Mg₅(Si₄O₁₁)₂(OH)₂ or other fibrous silicates (Figures 1-3).

In the talc mine, 80 cases of talcosis have been diagnosed under the medical supervision of Institute for Occupational Diseases since 1958 (male 70 cases, female 10 cases), exposure-onset duration ranging 5-22 years with an average duration of 13.6 years, grinder 57, excavator 19, worker for mineral separation 4. In talc-carving factory, 17 cases of talcosis were diagnosed, all of them are male, exposure-onset duration ranging 13-35 years with an average duration of 25.2 years. Of 97 cases of talcosis, 24 cases were complicated with tuberculosis (about 25%). In 73 cases of stage I talcosis, 12 cases (16.4%) complicated with tuberculosis, of 19 cases of the stage II talcosis, 9 cases (47.3%) were complicated ones. In 5 cases of stage III talcosis, complicated ones were 3 (60%). (Table I).

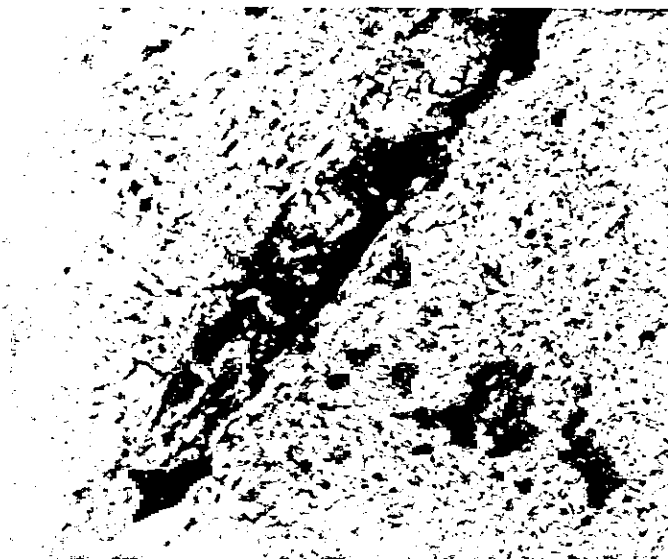

Figure 1. A fine streak of serpentine in talc in polarizing microscopy.

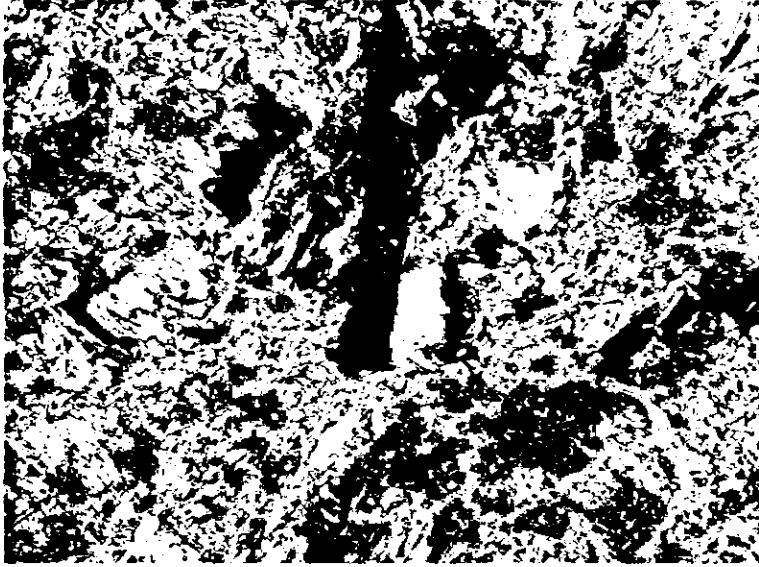

Figure 2. A bright silica particle in talc in polarizing microscopy.

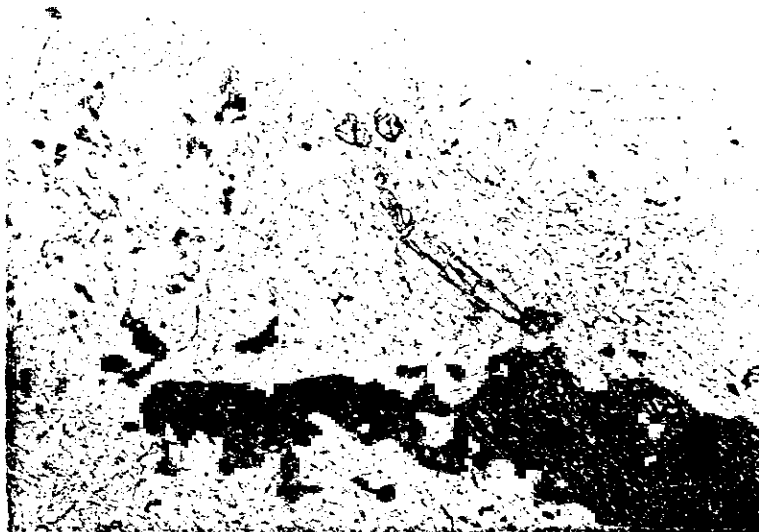

Figure 3. A few phosphorite particles in talc in polarizing microscopy.

X-RAY APPEARANCE

Unlike the radiographic appearance of silicosis, the enlarged hilar lymphnodes usually could not be found. The main characteristic findings of the talcosis were irregular small opacities; these abnormal findings must distribute beyond 2 zones for diagnosis. In some patients, the rounded small opacities were mainly observed. In most of them, the rounded opacities were 2-3 mm in diameter; occasionally, the rounded opacities were about 1 mm in diameter (Table II).

Nodular (Type) (15 cases): Of the 15 cases, 14 were grinders, exposure-onset duration was shorter than 10 years in 3 cases; 11-15 years in 11 cases; 16-20 years in 1 case. There were 3 cases of patients with 2nd stage talcosis, 2 cases with 3rd stage talcosis.

Reticulate-nodular Type: Of 56 cases, 40 were grinders, 16 excavators. The exposure-onset duration shorter than 10 years in 8 cases, 11-15 years in 22 cases, 16-20 years in 22 cases, more than 21 years in 4 cases. There was only one patient with 2nd stage talcosis.

Of 97 cases of talcosis, 5 cases with large shadow in the lung field, 3 of the cases were complicated with tuberculosis (Figures 4-8).

Pleural thickening, especially 'talc plaque' were not found in all of the patients. The relationship between the exposure-onset duration and the types of talcosis in 71 cases was noted (Table III).

COMMENTS

The relationship between silicates such as talc and pulmonary diseases was noticed at the end of 19th century, but the pulmonary damage and its X-ray changes in talc mine and talc processing workers had not been proved until the 30s of this century.^{1,2} Serial survey reports began to appear in China since 1958. It has long been noticed that some impurities in talc (tremolite etc.) can cause pulmonary fibrosis, although this has not been confirmed yet.³⁻¹⁰ In recent twenty years, the possibility of carcinogenesis by talc and impurities in talc was also a focus of much attention.¹¹⁻¹³

Some authors held that the main causation factors in talcosis is the fibrous tremolite $Ca_2Mg_5(Si_4O_{11})_2(OH)_2$. Talc has cytotoxic effect, while tremolite has fibrogenic, besides the cytotoxic effects. They also held that the detrimental effect was related to the length of these fibers. The longer the fibers, the larger the effect.

Table I
97 Cases of Talcosis (X-ray Classification)

	I Grade		II Grade		III Grade	
	Simple	Complicated	Simple	Complicated	Simple	Complicated
No. Cases	61	12	10	9	2	3

Table II
X-ray Appearance of 97 Cases of Talcosis

No.	Hilus			Marking		Emphysema		Ret. and Nod.	Nod.	Pin Poi.	Larg Shad.
	Disturb. of Constr.	Dens.	Enl.	Incr.	Def.	Loc.	Dif.				
80	57	23	89	75	10	6	75	14	6	6	

Notes: Ret.Reticulat, Nod.Nodular, Nod.Nodular, Poi.Point, Larg.Large, Shad. Shadow, Dist.Disturbance, Constr.Constructure, Dens.Density, Enl.Enlargement, Incr.Increasing, Def.Deformity, Loc.Localized, Dif.Diffuse,



Figure 4. A male, 54 years of age, talc-cutter exposure-onset duration—23 years, 2nd stage talcosis with tuberculosis (nodular type).

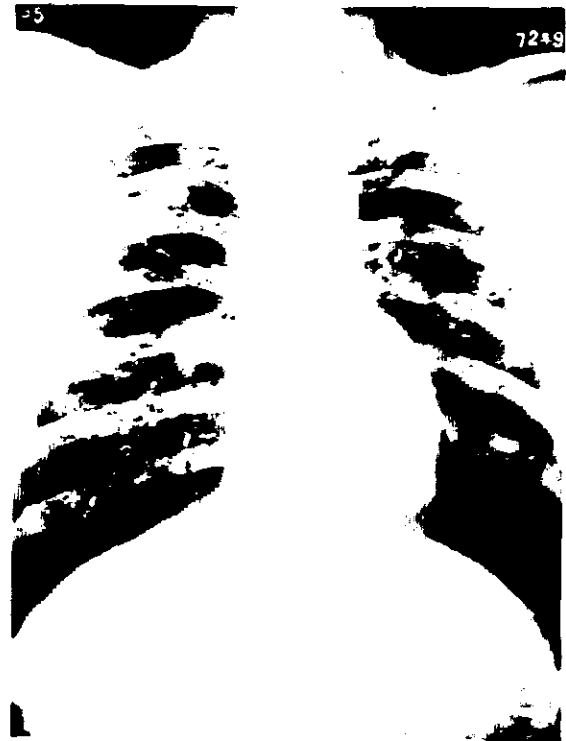

Figure 6. A male, 34 years of age, talc-cutter exposure-onset duration, 3rd stage talcosis.



Figure 5. A male, 29 years of age, talc grinder, exposure-onset duration—9 years, 2nd stage talcosis (reticulate—nodular type).



Figure 7. A male, 27 years of age, talc grinder, exposure-onset duration—6 years, 3rd stage talcosis.



Figure 8. A female, 29 years of age, talc powder packager, exposure-onset duration—5 years, 3rd stage talcosis with tuberculosis.

Table III
Relationship between the Exposure-onset Duration and the Types of Talcosis

Exposure-Onset Duration (yrs)	Nodular type					Reticulate-Modular Type				
	-5	6-10	11-15	16-20	21-	-5	6-10	11-15	16-20	21
Grinder	I	2	7*			1	7	16	15	1
	II	1	2							
	III		1	1						
Miner	I		1'					6	6	3
	II								1	
	III									

*Including 3 cases of pinpoint type. 'One case of pinpoint type.

A dichotomy has been identified in the classification of 'talc': asbestiform 'talc', including anthophyllite, tremolite and chrysotile, and non-asbestiform talc. Early studies did not recognize this dichotomy and their different effects.

The pathological changes of talcosis are diffuse pulmonary fibrosis and collagenic nodules. There were reports that 'asbestosis-like body' was found in the pulmonary tissue and localized pleural thickening, granuloma was found at autopsy or biopsy and its small opacities in the chest film disappeared after corticosterone treatment.

As regards to the various descriptions of the X-ray appearance of the talcosis, that is apparently related to the purity of the 'talc'. In workers exposed to asbestiform 'talc', their X-ray appearances look like those of asbestosis, especially the talc plaques can be seen and the films of the workers exposed to non-asbestiform talc, look like those of silicosis.

The workers in this series exposed to pure talc in which we can not find any fibrous mineral (without tremolite, anthophyllite, amosite or chrysotile), the reticulate and nodular opacities in early stage talcosis and the large shadows in the advanced talcosis can be observed. These X-ray appearances look like that of silicosis.

REFERENCES

1. Dreessen, W.C.: Effect of Certain Silicate Dusts on the Lungs. *J. Ind. Hyg.* 15:66-78 (1933).
2. Drossen, W.C. et al.: The Effects of Exposure to Dust into Georgia Talc Mills and Mines, *Public Health Reports*, 50:131-143 (1935).
3. Seegal, W. et al.: The Dust Hazard in Tremolite Talc Mining, Including Roentgenological Findings in Talc Workers. *Amer. J. Roentgenol. Radium Therapy*, 49:11-29 (1943).
4. Greenberg, L.: The Dust Hazard in Tremolite Talc mining, *Yale J. Biol. Med.* 19:481-501 (1947).
5. Weiss, B. et al: Commercial Talc and Talcosis. *Arch. Environ. Health.* 14:304-308 (1967).
6. Kleinfeld, M. et al: Mortality Among Talc Miners and Millers in New York State. *Arch. Environ. Health.* 14:663-667 (1967).
7. Gamble, J. et al: An Epidemiological Industrial Hygiene Study of Talc Workers. *Ann. Occup. Hyg.* 26:841-859 (1982).
8. Berller, A. et al.: Talc Dust Pneumoconiosis. *Acta. Path. Microbiol. Scan. Sec. A.* 89:17-21 (1981).
9. Bowen, J.H. et al: Infantile Pulmonary Hypertension Associated with Foreign Body Vasculitis. *Am. J. Clin. Pathol.* 75:609-614 (1981).
10. Kleinfeld, M. et al.: Talc Pneumoconiosis, A Report of Six Patients with Postmortem Findings, *Arch. Environ. Health.* 7:101-115 (1963).
11. Merliss, R.R.: Talc-Treated Rice and Japanese Stomach Cancer, *Science.* 173:1141-1142 (1971).
12. Blejer, H.P. et al.: Talc Possible Occupational and Environmental Carcinogen. *J. Occup. Med.* 15:92-97 (1973).
13. Matsudo, H. et al.: Japanese Gastric Cancer, Potentially Carcinogenic Silicates (talc) from Rice. *Arch. Pathol.* 97:366-368 (1974).

PULMONARY ALVEOLAR PROTEINOSIS AND CEMENT DUST: A CASE REPORT— A PRELIMINARY REPORT

ROBERT J. McCUNNEY,* M.D., MPH • Robert Godefroi,† M.D., MPH

*Cabot Corporation, 950 Winter St., P.O. Box 9073, Waltham, MA 02254, USA

†Boston Univ., Medical Ctr., Occup. Health Program, 75 E. Newton St., Boston, MA 02118, USA

ABSTRACT

A twenty nine year old white male developed pulmonary alveolar proteinosis within two years of working as a cement truck driver. Pulmonary alveolar proteinosis (PAP), an uncommon respiratory disorder characterized by the accumulation of phospholipid material within the alveoli, has been described in association with exposure to silica, aluminum oxide and a variety of dusts and fumes. Although a link between exposure to Portland cement and PAP has not been previously noted, this type of cement contains upwards of 20% silica. Lung biopsy material, originally used to diagnose PAP, was reviewed under electron dispersive spectroscopy. Analysis indicated the presence of silica particles within the alveolar fluid and macrophages. A number of items support a causal relationship between exposure to cement dust and PAP: (1) the temporal sequence between assuming job duties and the development of the illness, (2) improvement following removal from further exposure, (3) dusty, unprotected working conditions, (4) the presence of silica within the cement and the alveolar fluid from periodic acid-Schiff positive lung tissue.

INTRODUCTION

Pulmonary alveolar proteinosis (PAP) an uncommon respiratory disorder first reported in 1958,¹ consists of the accumulation of periodic acid-Schiff (PAS) positive phospholipid material in the alveoli; inflammation of the lung interstitium usually does not occur. PAP can be a primary disease process or secondary to opportunistic infections;²⁻⁴ it has also been described in AIDS patients.⁵ Although the etiology of the disorder is poorly understood, the disease process appears to involve a disruption of the pulmonary surfactant—type II epithelial cell system.²⁻⁶ Animal studies have demonstrated that PAP develops after exposure to a variety of mineral dusts and fumes,⁷⁻¹³ whereas other reports have associated PAP with exposure to various occupational substances.¹⁴⁻¹⁹ The purpose of this report is to describe a truck driver, who appears to have developed (PAP) as a result of exposure to Portland cement dust, a relationship not previously noted.

CLINICAL HISTORY

A twenty nine year old white male was referred for an occupational medical consultation. He was concerned as to whether his recent diagnosis of pulmonary alveolar proteinosis may have resulted from exposure to cement dust and whether it would be harmful for him to return to his work.

Initial evaluation included a review of medical records, a medical history, a comprehensive physical examination and laboratory testing such as a chest film, pulmonary function testing, allergy evaluation and review of diagnostic material, including results of an open lung biopsy. The patient, who had twenty-two pack year smoking history (1½ packs per day for

15 years) originally became ill in February, 1982 when he experienced a cough, with purulent sputum production, fever, and chest pain.

A chest film revealed diffuse bilateral alveolar infiltrates, suggestive of an acute pneumonia; the right lung was more affected than the left (Figure 1). He was prescribed ten days of penicillin and tetracycline for a presumed lower respiratory infection and clinically improved thereafter. A subsequent chest film (March, 1982) however, demonstrated persistent bilateral infiltrates. A PPD was negative and psittacosis serology was unremarkable. Pulmonary function tests later (May, 1982) revealed normal lung function (Table I). Since a repeat chest film revealed a persistence of the pulmonary infiltrates (Figure 2) the patient was advised to undergo bronchoscopy with transbronchial biopsy. Pathology review demonstrated PAS positive proteinaceous material within the alveoli, consistent with PAP (Figure 3).

In December, 1982, the patient developed acute dyspnea on exertion. Repeat PFTs demonstrated a deterioration of lung function (FEV₁: 3.62L—3.15L FVC 4.28L—3.79L). A room air arterial blood gas revealed a PO₂ of 73mm Hg, PCO₂ of 37mm Hg and a pH of 7.39. Because of persistent dyspnea on exertion, therapeutic bilateral whole lung bronchopulmonary lavage was performed in January 1983. Lavage resulted in marked clinical improvement as well as in pulmonary function. By May 1983, the patient was clinically well; pulmonary function also improved. Evaluation in August 1986, revealed the patient to be free of pulmonary symptoms although chest X-ray abnormalities persisted and PFTs suggested mild obstructive airways disease (Table I). The patient continued to smoke one and one-half packs of cigarettes per day. Clinical evaluation at that time also included allergy skin



Figure 1. Chest film (initial).

Table I
Lung Function Values

	<u>FEV₁ (L)</u>	<u>FVC (L)</u>	<u>FEV₁/FVC</u>	<u>SINGLE BREATH DIFFUSION CAPACITY</u>
May 1982	3.62 (89% pred)	4.28 (84% pred)	83%	81% pred
Sept 1982	3.64 (91% pred)	4.27 (92% pred)	85%	-----
December 1982	3.15 (77% pred)	3.79 (74% pred)	85%	64% pred
May 1983	3.27 (81% pred)	4.33 (85% pred)	76%	-----
**August 1986	3.00 (76% pred)	4.06 (81% pred)	73%	

** negligible improvement after bronchodilators

FEV₁ 3%; FVC 1%



Figure 2. Chest film.

testing for common substances such as dusts, ragweed, trees and grass, all of which were negative.

Biopsy material was further reviewed for the presence of inorganic particles, which have been previously reported in association with PAP.²⁵ Through electron dispersive spectroscopy (EDS), silicon particles (Figure 4) were noted in the lung biopsy material. An increased number of small birefringent particles had been noted earlier within the same proteinaceous material.

OCCUPATIONAL HISTORY

For almost two years prior to becoming ill, the patient operated a cement truck in a railroad freight yard. He oversaw the transfer of portland cement from railroad tank cars into the cylindrical tank of the truck that he drove. Heavy exposure to cement dust occurred (Figures 5-7) during the one to one and one-half hours required per load; two to three loads were transferred daily. By the end of the day, the patient claimed his hair, nose and skin were covered with dust. No dust mask or respirators were used. Air monitoring to quantify cement dust exposure was not conducted.

Portland Cement, commonly called cement, is classified by OSHA and ACGIH as a nuisance dust; a Time Weighted Average (TWA) Threshold Limit Value (TLV) of 10 mg/m³ is recommended. Portland Cement consists of hydrated

calcium silicates with small amounts of aluminum oxide, magnesium oxide, iron oxide, calcium sulfate and other impurities.

The chemistry and manufacture of various Portland cements, blended cements, and other hydraulic cements are related to their specifications and uses in concrete and other products. Portland cements are ordinarily manufactured from raw mixes including components such as calcium carbonate, clay or shale, and sand. Table II shows the compositions of some typical raw materials.²⁰⁻²¹

During the manufacture of Portland cement, as the temperature of the materials is increased, the following reactions occur: (1) evaporation of free water; (2) release of combined water; (3) decomposition of carbonates (calcination); and (4) combination of the lime, silica, alumina and other oxides. This produces a mixture of solid and molten phases in the CaO+SiO₂+Al₂O₃ system which crystallizes during cooling to form a mixture of solid calcium silicates and calcium aluminate containing small amounts of magnesium oxide, iron oxide, calcium sulfate and other impurities. Table III shows the composition of some typical cements. Table IV shows the crystalline phases present.^{20,22} Table V shows the phases present after hydration at normal temperatures.^{20,23}

Of the components of Portland cement, calcium silicate, magnesium oxide, aluminum oxide, iron oxide and calcium

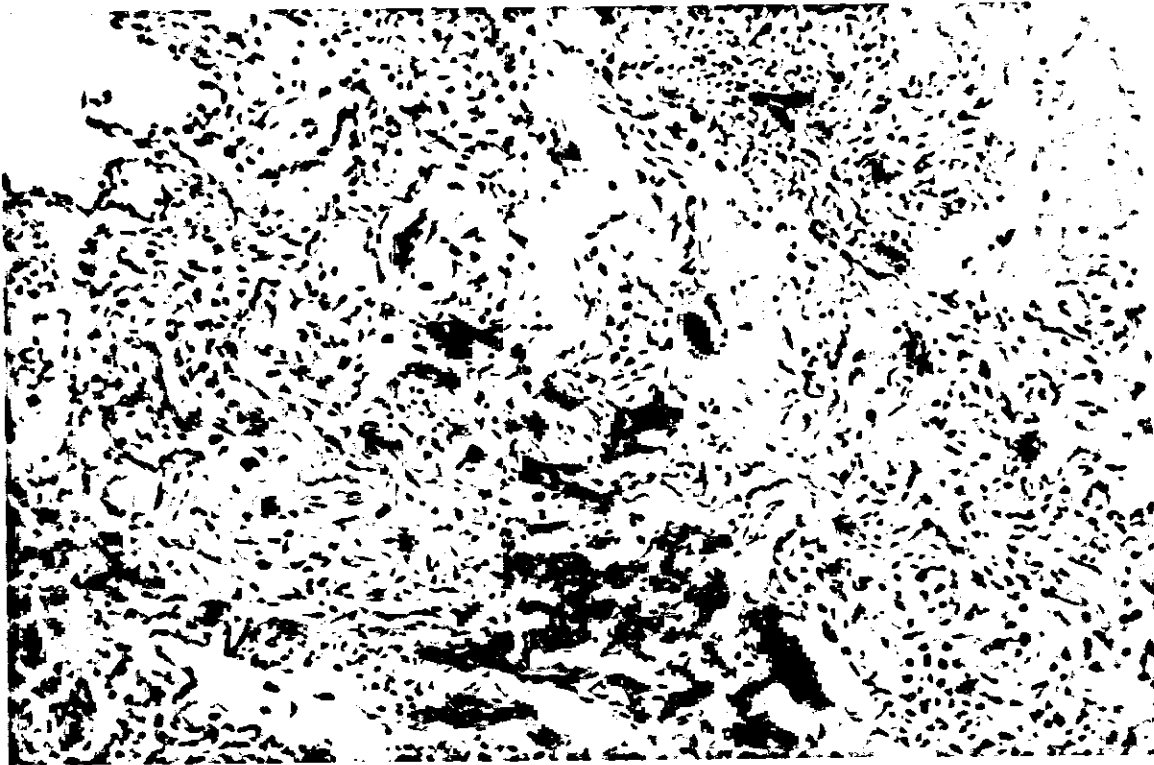
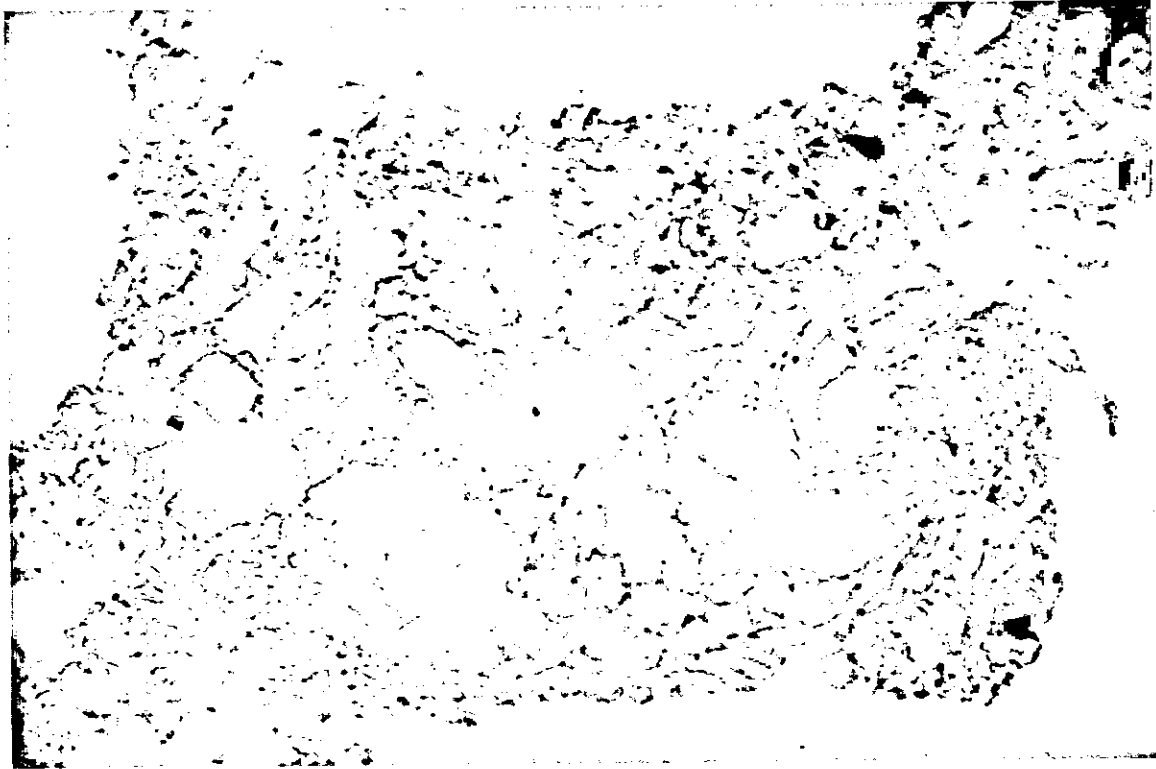

Figure 3A, 3B. Periodic acid-Schiff material (lung biopsy).



Figure 3C. Periodic acid-Schiff material (lung biopsy) (cont.).

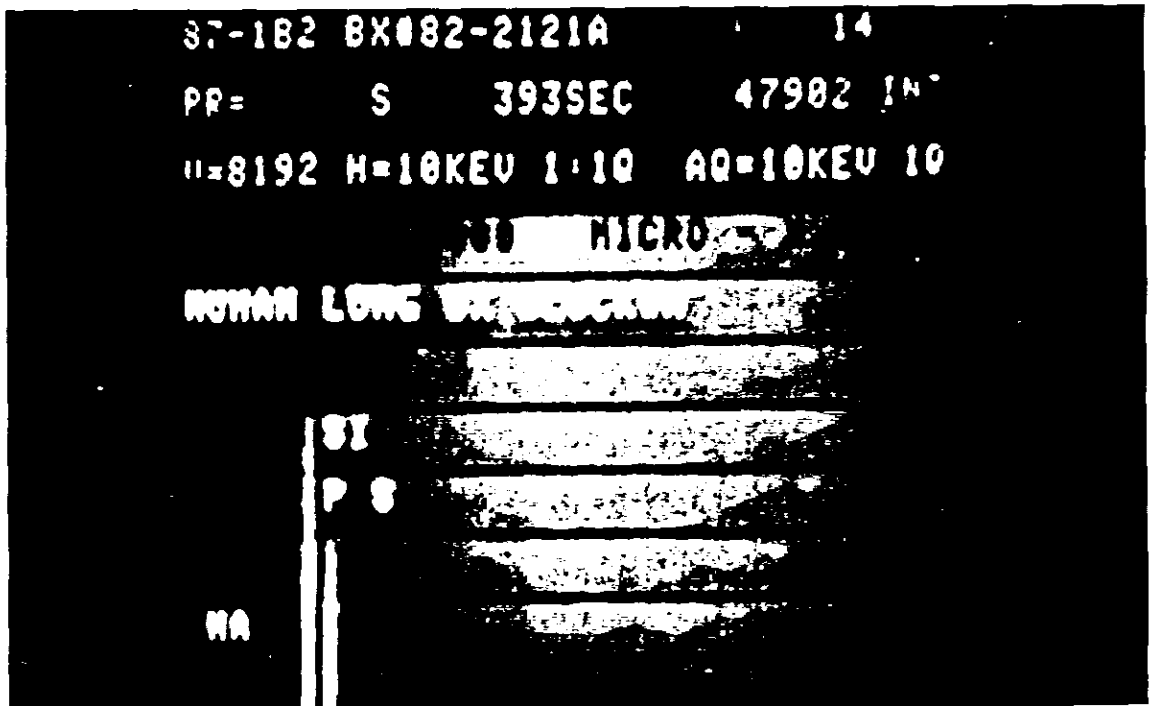

Figure 4A, 4B. Electron dispersive spectroscopy (A) Silica particle.



Figure 4A, 4B. Electron dispersive spectroscopy (A) Silica particle (cont'd).



Figures 5, 6. Working conditions.



Figure 7. Working conditions (cont.).

Table II
 Chemical Composition of Raw Materials, %
 (Courtesy of the American Concrete Institute)^{20,21}

Type	SiO ₂	Al ₂ O ₃	Fe ₂ O ₃	CaO	MgO
Cement Rock	13.4	3.5	1.7	42.9	1.0
Limestone	1.2	0.2	0.4	53.4	1.3
Limestone	4.5	0.5	1.6	35.0	14.9
Marl	6.0	0.6	2.3	49.1	0.4
Oyster Shells	1.5	0.4	1.2	52.3	0.7
Shale	53.8	18.9	7.7	3.2	2.2
Clay	67.8	14.3	4.5	0.9	1.2
Mill Scale			ca 100.0		
Sandstone	76.6	5.3	3.1	4.7	1.7
Bauxite	10.6	57.5	2.6		

sulfate are assigned TLV's of 10mg/m³ by the ACGIH; calcium hydroxide and magnesium are assigned TLV's of 5mg/m³.

DISCUSSION

The relationship of PAP to occupational exposures was first raised in 1969 by Davidson and MacLeod¹⁶ who reviewed

139 cases of PAP that had been reported since 1958 and found that approximately half were associated with fume or dust exposures. Rosen et al,¹ however, in their classic paper, reported on the occupations of the 27 cases they described. It is ironic that the first patient they described was a cement truck driver. McEuen and Abraham later (1978)²⁴ evaluated 37 cases of PAP and found that 13 of their series had been exposed to various dusts and fumes. In their retrospective

Table III
Chemical Composition of Some Typical Cements, %

Type	SiO ₂	Al ₂ O ₃	Fe ₂ O ₃	CaO	MgO	SO ₃
Type I	20.9	5.2	2.3	64.0	2.8	2.9
Type II	21.7	4.7	3.6	63.6	2.9	2.4
Type III	21.3	5.1	2.3	64.9	3.0	3.1
Type IV	24.3	4.3	4.1	62.3	1.8	1.9
Type V	25.0	3.4	2.8	64.4	1.9	1.6
White	24.5	5.9	0.6	65.0	1.1	1.8
Alumina	5.3	39.8	14.6	33.5	1.3	0.4

Table IV
Compound Composition of Some Typical Cements, %
Calculated by the ASTM C150-76)

Crystalline Form

Cement	(2)	(3)	(4)	(5)
Type I	55	19	10	7
Type II	41	24	6	11
Type III	56	19	10	7
Type IV	28	49	4	12
Type V	38	43	4	9
White	33	46	14	2

Column Headings:

- (2) Tricalcium Silicate
- (3) Dicalcium Silicate
- (4) Tricalcium Aluminate
- (5) Tetracalcium Alumino-ferrite

Table V
Cement Phases Hydrated at Normal Temperatures

<u>Name</u>	<u>CAS Registry No.</u>
Calcium Sulfate Dihydrate (Gypsum)	10101-41-4 & 13397-24-5
Calcium Hydroxide (Portlandite)	1305-62-0
Magnesium Hydroxide (Brucite)	1309-42-8
Calcium Silicate Hydrate Gel (C-S-H gel)	12323-54-5
Tetracalcium aluminate 19-hydrate	12042-86-3
Tetracalcium aluminate 13-hydrate	12042-85-2
Tetracalcium aluminate 7-hydrate	12511-52-3
Tetracalcium aluminate monosulfate 16-hydrate	67523-83-5
Tetracalcium aluminate monosulfate 14-hydrate	12421-30-6
Tetracalcium aluminate monosulfate 12-hydrate	122522-10-7
4-Calcium aluminate sulfate 10,8,x-hydrate	12252-09-4 & 12445-38-4
Ettringite (6-calcium aluminate trisulfate, 32-hydrate)	12252-15-2
6-Calcium aluminate trisulfate, 8-hydrate	11070-82-9
Garnet-hydrogarnet Solid Solution Series	12042-80-7

review, the same authors also found an increased number of small, inorganic particulates in the lung tissue as compared to controls. Crystalline silica is the most commonly implicated mineral associated with PAP.^{15,18,19,24,25}

PAP has also been described secondary to exposure to Kaolin,¹⁴ an aluminum silicate compound, and aluminum dust.¹⁷ In these cases, minerologic analysis of lung tissue revealed high concentrations of aluminum silicate and aluminum particulates, respectively.

Although PAP has a variable prognosis, this patient's clinical improvement after a single pulmonary lavage is unusual. Kariman et al²⁶ for example, described complete remission or marked subjective and objective improvement in only two of eleven cases treated in this manner. Wilson et al²⁷ reported PAP in a welder who was successfully treated by a single bronchial lavage and removal from further occupational and environmental exposure to dusts and fumes. The improvement in our patient after a single pulmonary lavage and removal from further exposure to cement dust lends credence to the notion that PAP may be initiated by a nonspecific injury that results in a transient failure of alveolar clearance and the accumulation of surfactant materials.¹⁸

Documentation of an increased amount of inorganic particulates containing silicon within the biopsy material supports the notion that inhalation of cement dust precipitated the development of PAP in this patient. Abraham and McEuen²⁵ have also reported two individuals exposed to cement dust in

whom an increased number of inorganic particulates (silicates found in cement dust) were noted in the proteinaceous lung tissue.

Further studies are necessary to elucidate the relationship between PAP and smoking. Abraham and McEuen²⁵ were not able to document smoking histories in their analysis of PAP cases. The role of smoking in the deposition of small particulates in the lung also needs further exploration.²⁸

Workers involved in the manufacture of cement dust have also been evaluated. One study of 160 cement workers in Yugoslavia indicated a decline in pulmonary function (FEV₁, FVC, FEV₁/FVC) following four years of unspecified level of exposure; the authors controlled for cigarette smoking.²⁹ Similar analyses among cement workers have indicated obstructive defects³⁰ (decline in FEV₁/FVC), expiratory airflow obstruction³¹ and a higher prevalence of respiratory symptoms,³² even when controlled for cigarette smoking.

CONCLUSION

Pulmonary alveolar proteinosis is a rare disorder that in some cases "represents one mechanism by which the lung responds to a variety of insults."³³ Dust overload can provoke excessive discharge of surfactant and associated lipids from type II pneumocytes.³⁴ The mechanism for this reaction may be simply mechanical and not related to the presence of fibrogenic material. It is the destruction of the type II alveolar epithelial cells that leads to PAP. Although the amount of

cement dust to which this patient was exposed is unclear, verbal accounts ("it was so thick, that sometimes I couldn't see") and pictures (Figures 5-7) of the operations suggest that the working conditions were unarguably dusty and likely excessive at times. After a *single* intratracheal instillation of silica dust, laboratory animals developed PAP within three weeks.³⁵ The presence of silica particles within both alveolar macrophages and alveolar fluid and the temporal sequence of the patient developing PAP within 2 years of assuming his job responsibilities and improvement following removal from exposure lend further support to a causal relationship.

Whether this patient is at risk of recurrence of PAP upon further exposure to dusts is problematic. Prudence would dictate, however, that in light of PAP being a potentially life threatening illness, such exposure should be avoided.

REFERENCES

- Rosen, S.H., Castleman, B., Liebow, A.A.: Pulmonary Alveolar Proteinosis. *N Engl J Med.* 1958; 258:1123-42.
- Bedrossian, C.W., Luna, M.A., Conklin, R.H., Miller, W.C.: Alveolar Proteinosis as a Consequence of Immunosuppression. *Human Pathology*, 1980; 11 (Suppl): 527-535.
- Reyes, J.M., Putong, P.B. Association of Pulmonary Alveolar Lipoproteinosis with Mycobacterial Infection. *Am. J. Clin. Pathol.* 1980; 74:478-485.
- Singh, G., Bedrossian, C.W., Rogers, R.M.: Pulmonary Alveolar Proteinosis; Staining for Surfactant. Apoprotein in Alveolar Proteinosis and in Conditions Stimulating It. *Chest* 1983; 83:82-86.
- Ruben, F.L., Talamo, T.S.: Secondary Pulmonary Alveolar Proteinosis Occurring in Two Patients with Acquired Immune Deficiency Syndrome. *Amer J Med.* 1986; 88:1187-1190.
- Claypool, W.D., Rogers, R.M., Matuschak, G.M.: Update on the Clinical Diagnosis, Management and Pathogenesis of Pulmonary Alveolar Proteinosis (Phospholipidosis). *Chest* 1984; 85(4):550-558.
- Corrin, B., King, E.: Pathogenesis of Experimental Pulmonary Alveolar Proteinosis. *Thorax* 1970; 25:230-236.
- Governa, M., Valentino, M., Tosi, P., et al.: Pulmonary Alveolar Lipoproteinosis in Rats Following Intratracheal Injection of Pyrite Particles. *J. of Toxicol. Environ. Health* 1986; 19:403-412.
- Gross, P., Nau, C.A.: Lignite and the Derived Stream-Activated Carbon: The Pulmonary Response to Their Dust. *Arch Environ Health* 1967; 4:450-460.
- Gross, P., DeTreville, R.T.: Alveolar Proteinosis: Its Experimental Production in Rodents. *Arch Pathol.* 1968; 86:255-261.
- Lee, K.P., Barras, C.E., Griffith, F.D., Waritz, R.S.: Pulmonary Responses to Glass Fiber by Inhalation Exposure. *Lab Invest.* 1979; 40:123-133.
- Sanders, C.L., Conklin, A.W., Gelman, R.A., Adee, R.R., Rhoads, K.: Pulmonary Toxicity of Mount St. Helen's Volcanic Ash. *Environ. Res.* 1982; 27:118-135.
- Governa, M., Valentino, M., Tosi, P., et al: Pulmonary Alveolar Proteinosis in Rats Following Intratracheal Injection of Pyrite Particles. *J. Toxicol. Environ. Health* 1986; 19:403-412.
- Abraham, J.L., Auchincloss, J.H.: Pulmonary Alveolar Proteinosis Associated with Kaolin Exposure. *Am. Rev. Resp. Dis.* 1985; 131:A208.
- Buechner, H.A., Ansari, A.: Acute Silico-Proteinosis. *Dis. Chest.* 1969; 55:274-284.
- Davidson, J.M., MacLeod, W.M.: Pulmonary Alveolar Proteinosis. *Br. J. Dis. Chest* 1969; 63:13-28.
- Miller, R.R., Churg, A.M., Hutcheon, M., Lam, S.: Pulmonary Alveolar Proteinosis and Aluminum Dust Exposure. *Am. Rev. Resp. Dis.* 1984; 30:312-315.
- Surat, P.M., Winn, W.C., Brody, A.R., Bolton, W.K., Giles, R.D.: Acute Silicosis in Tombstone Sandblaster. *Am. Rev. Resp. Dis.* 1977; 115:521-529.
- Xipell, J.M., Hamk, N., Price, C.G., Thomas, D.P.: Acute Silicoproteinosis. *Thorax* 1977; 32:104-111.
- Helmuth, R.A., Miller, F.M., O'Connor, T.R., Greening, N.R.: Portland Cement Association Article on Cement, *Kirk-Othmer Encyclopedia*, 3rd edition. Vol. 05, 163-193.
- McMillan, F.R., Hansen, W.C.: *J. Am. Concr. Inst.* 44:553-565 (1948) (Table 2).
- 1976 Annual Book of ASTM Standards, Part 13, American Society for Testing and Materials, Philadelphia, PA 1976 p. 138 (Table 3).
- Guide to Compounds of Interest in Cement and Concrete Research, Special Report 127, Highway Research Board, National Academy of Sciences, Washington, D.C., 1972 (Table 4).
- McEuen, D.D., Abraham, J.L.: Particulate Concentrations in Pulmonary Alveolar Proteinosis. *Environ. Res.* 1978; 17:334-339.
- Abraham, J.L., McEuen, D.D.: Inorganic Particulates Associated with Pulmonary Alveolar Proteinosis: SEM and X-ray Microanalysis Results. *Appl. Path.* 1986; 4(3):138-146.
- Kariman, K., Kylstra, J.A., Spock, A.: Pulmonary Alveolar Proteinosis: Prospective Clinical Experience in 23 Patients for 15 Years. *Lung* 1984; 162:223-231.
- Wilson, J.W., Rubinfeld, A.R., White, A., Mullerworth, M.: Alveolar Proteinosis Treated with Single Bronchial Lavage. *Med. Jour. of Australia* 1986; 145:158-160.
- Brody, A.R., Craighead, J.E.: Cytoplasmic Inclusions in Pulmonary Macrophages of Cigarette Smokers. *Lab. Invest.* 1975; 32:125-132.
- Saric, M., Kalacic, I., Holetic, A.: Follow-up of Ventilatory Lung Function in a Group of Cement Workers. *Brit. J. Ind. Med.* 1976; 33:18-24.
- Kalacic, I.: Ventilatory Lung Function in Cement Workers. *Arch. Environ. Health* 1973; 26:84-85.
- Kalacic, I.: Early Detection of Expiratory Airflow Obstruction in Cement Workers. *Arch. Environ. Health* 1974; 29:147-149.
- Kalacic, I.: Chronic Nonspecific Lung Disease in Cement Workers. *Arch. Environ. Health* 1974; 26:78-83.
- Rubin, E., Weisbrod, G.L., Sanders, D.E.: Pulmonary Alveolar Proteinosis: Relationship to Silicosis and Pulmonary Infection. *Radiology* 1980; 135:35-41.
- Corrin, B., King, E.: Pathogenesis of Experimental Pulmonary Alveolar Proteinosis. *Thorax* 1970; 25:230-236.
- Gross, K.B., White, H.J., Smiler, K.L.: Functional and Morphological Changes in the Lungs After a Single Intratracheal Installation of Silica. *Am. Rev. Respir. Dis.* 1984; 129:833-839.

PERSONAL DUST SAMPLING WITH THE CIP-10 FOR A BETTER MEDICAL MANAGEMENT OF THE PNEUMOCONIOSIS RISK IN COAL MINES

M. ZITTER • B. Mahieu • E. de Surgy • P. Sebastien • G. Auburtin • A. Mas
Houilleres du Bassin de Lorraine, Freyding-Merlebach, France

INTRODUCTION

In French coal mines, static sampling is used for regulatory measurements of ambient dust concentrations in workings. In 1983 however, the personal dust sampler CIP-10 became commercially available. This air sampling instrument was designed by CERCHAR ("Centre d'Etudes et Recherches de Charbonnages de France") to measure individual exposures to respirable dust in mining environments.

The CIP-10 is a small (18 x 7 x 2.5 cm) and light (300 g) instrument, conveniently worn by the miners. It can be lodged into a chest pocket or into a chest strap. Wearing the CIP-10 is generally well accepted by the workers. The sampler is operating at a flow rate of 10 l/min and collects the respirable fraction of the dust within a rotary foam. Dust can be ashed or extracted from the foam for laboratory analyses, such as free silica determination. The CIP-10 has enough autonomy to cover a full 8-hour shift. More technical information on the CIP-10 is available elsewhere (Courbon et al, 1988).

Personal sampling greatly modified our existing views on dust exposure in coal mines. Results of a large scale monitoring study of personal exposures to respirable dust in French coal mines have just been reported (Bruyet et al, 1988). Several more specific surveys were carried-out at the request of the

occupational physicians from collieries in Lorraine. They provided other useful informations, examples of which are given in this report.

USEFULNESS OF PERSONAL DUST SAMPLING

Documenting Specific Exposures

In French mines, some goafs must be filled-up, especially in the case of flat working, when heating, water irruption or mining damages are feared. When hydraulic stowing is not possible, pneumatic stowing is sometimes used to fill-up the goafs with shales. The shales are collected in the washing plants, sent back underground with successive tubings, belt-conveyed to the face and sprayed out pneumatically from a stowing machine located in the top road. Since it was often found in the career of pneumoconiotics, this technique was suspected to carry a substantial pneumoconiosis risk.

In February 1984, a survey was carried out in a particular working at Wendel mine to measure personal exposures associated with the pneumatic stowing technique. For a period of 10 days, all workers engaged in the operation and two technicians were equipped with a CIP-10. Measurement results are reported in Tables I and II. Concentrations of respirable dust were in the range 11.2-91.5 mg/m³. Such

Table I
Personal Dust Sampling with the CIP 10
Pneumatic Stowing Technique
Wendel Pit, February 1984

		20/2	21/2	22/2	23/2	24/2	27/2	28/2	29/2	1/3
Pneumatic	T n°138	3,70	8,00	15,30	9,00	20,10	6,40	7,20	40,00	12,50
	T n°139	6,70	7,40	11,70	8,80	14,10	7,10	6,70	37,50	15,40
Stowing	Mean	5,20	7,70	13,50	8,90	17,10	6,70	6,90	38,70	14,00
Technique	S n°140	11,20	52,50	77,70	39,50	33,50	22,10	55,90	91,50	68,50
	Ratio S/T	115%	581%	475%	343%	95%	230%	710%	136%	389%

RESULTS OF RESPIRABLE DUST IN MG/M3

T = Technicians

S = Stower

Table II
Personal Dust Sampling with the CIP 10

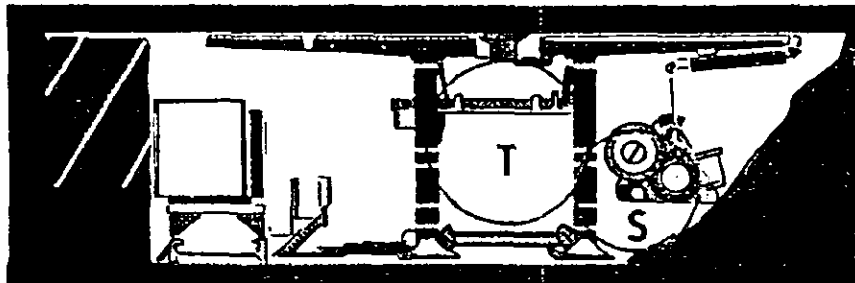
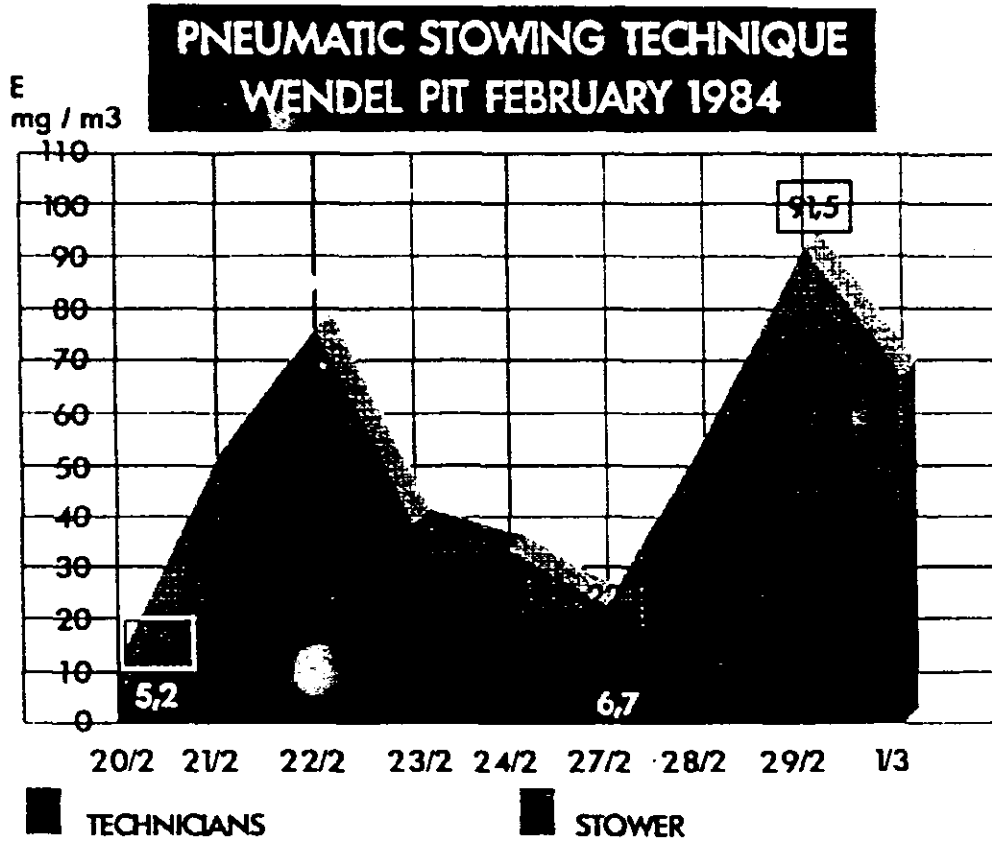

RATIO STOWER / TECHNICIANS

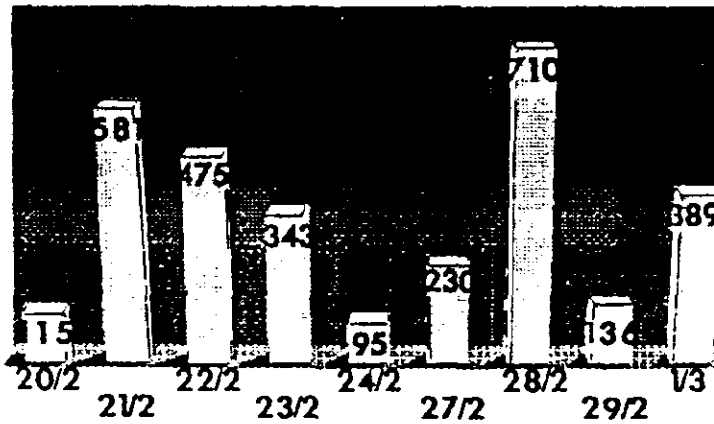

high figures are reported with caution, since a saturation effect was observed with the CIP-10 at very high concentrations. The stower was the most exposed. By-standers could be 8 times less exposed. Pneumatic stowing was also affecting the exposures of people at the face. The pneumatic stowing technique is not used any more in mines from Lorraine since the end of 1986.

Other surveys with the CIP-10 were able to document unsuspected exposures, such as those experienced by the electromechanics underground. These people maintain the energy sources and the mining equipment. They generally stand out of the face, except in case of failure of the machinery. Because not directly involved in coal extraction, they are not considered as "exposed" personnel according to regulations.

In the period June 10th-June 19th 1987, all electromechanics from a working wore a CIP-10. Their activities were observed and recorded. Tables III and IV present measurements of personal exposures and of ambient concentrations 15 m above the working in the top road on the air return. Values for personal exposures were linearly related to the time spent at the face or in the top road. The highest exposure reached the standard level for regulatory ambient concentration.

In another survey, the exposures of 16 workers involved in heading operations in the seams were measured during 5 days. Three exposure zones were defined: (1) the shearing

area, (2) between the shearing area and the deduster and (3) from the back of the deduster up to the entrance of the headings. A total of 55 measurements were done. Among those, 16 were in excess of 2 mg/m³. Interestingly enough, most of the excessive exposures occurred in zone 3, a day when the shearer did not operate. (Tables V and VI).

Assessing the Validity of Job Re-allocation

In French collieries, medical management of the pneumoconiosis risk is mainly based on job re-allocation. Diagnosed cases are moved to workings known to be less dusty. The dustiness of each working is deducted from the results of regulatory measurements done by static sampling. A survey was carried out with the CIP-10 in order to check if this way of re-allocating jobs was effectively ensuring less severe personal exposure for these diagnosed cases.

In Summer 1987, 40 active miners with a chest X-ray scored 0/1 and 30 active miners compensated for pneumoconiosis were selected. Personal exposures of workers in the two groups were assessed by a total of 476 measurements with the CIP-10. Results are reported in Tables VII and VIII. In average, exposures were less for pneumoconiotics (0.63-0.67 mg/m³) than for other re-allocated but uncompensated workers (0.89 mg/m³). Some personal exposures in excess of 2 mg/m³ were, however, detected (Mahieu et al, 1988). These cases were immediately corrected.

Table III
Personal Dust Sampling with the CIP 10

DATE	Static Meas-ures	EXPOSURE SITES DURING THE SHIFT									
		Entry & Bottom road		Bottom road		Bottom road Coal face & Top road		Coal face & Top road		Top road	
		mg/m ³	%	mg/m ³	%	mg/m ³	%	mg/m ³	%	mg/m ³	%
10/6	1	3,98				1,72	4,32	3,30	82,90		
	2	5,15						3,72	93,40	(0,50)	
								2,49	48,30		
								2,53	49,10		
11/6	1	4,17		1,94	46,50	3,80	91,10			4,27	102,30
	2	1,83		1,34	73,20						
				1,58	86,30						
				1,32	72,10						
12/6	1	4,17		1,84	44,10					4,28	102,60
	2	4,09						3,00	73,30	3,85	92,30
		4,99								5,05	101,20
15/6	1	(0,33)	1,66							3,87	
	2	4,21				2,97	70,50			3,96	
						2,79	66,20			4,04	95,90
16/6	1	5,20		2,97	57,10					5,89	113,20
	2	5,79				1,86				5,89	113,20
						3,92	67,70				
17/6	1	5,99		3,07	51,20					3,72	62,10
	2			1,83		5,24				6,14	120,50
18/6	1	5,23		1,70	32,50	4,04	77,20				
	2	5,81				3,54	67,60				
						2,99	51,40	4,25	73,50		
19/6	1	4,26				1,83	42,90			5,31	124,60
	2			1,35		2,85	66,90				
						2,50					
						1,24					
Values		14,00		10,00	8,00	14,00	10,00	6,00	6,00	12,00	10,00
Means		4,63	1,00	1,89	57,88	2,95	60,58	3,22	70,08	4,69	102,79
SEH		1,03	1,66	1,60	16,78	1,05	22,45	1,63	16,56	1,87	16,80

PERSONAL DUST SAMPLING WITH THE CIP 10
ELECTROMECHANICS
MARIENAU PIT Seam ED
JUNE 1987

Results of respirable dust in mg/m³

Results of individual measures % in the ratio of ambient regulatory measurements (15 m above the working in the top road on the air return)

(*) doubtful values

Table IV
Personal Dust Sampling with the CIP 10

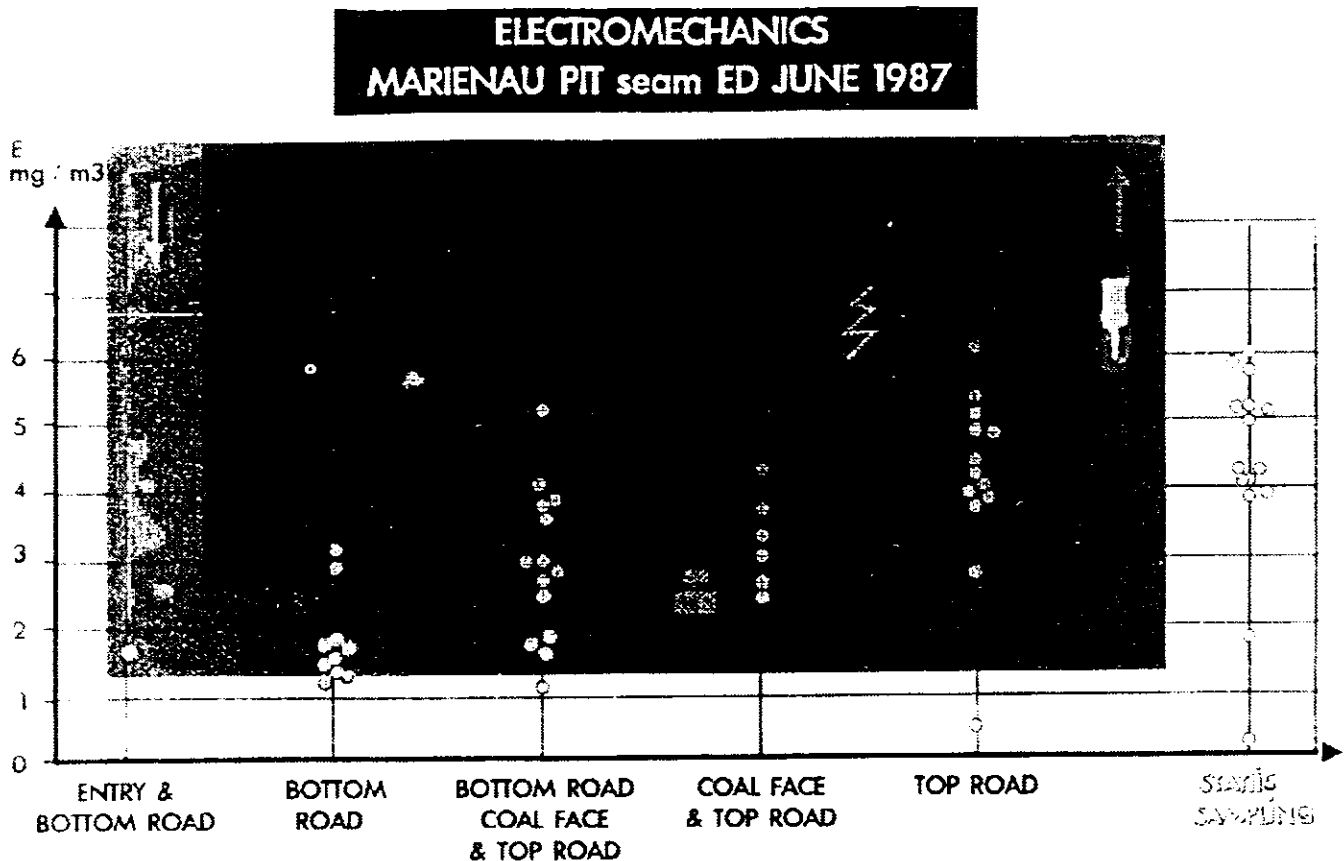

DISCUSSION

According to the governmental directives of December 1975, in the French coal mines the concentration of respirable dust is regularly controlled and measured by static ambient sampling in well-defined locations. The respirable dust is collected using the CPM3 air sampling instrument (Fabries et al., 1987). Workings are ranked according to their dustiness. Standard levels are in terms of gravimetric concentration of respirable dust (as collected by the CPM3) in the ambient air. The observed differences in the pneumoconiotic risk among coal fields (Amoudru, 1987) have been taken into account to define standard levels which are specific to each coal field. In Lorraine, the standard level is at 4.5 mg/m³ below 7% free silica, and gradually decreases above 7%. All the workings are regularly classified according to this level.

Also the regulations impose for any worker exposed an annual medical examination and a chest X-ray. At the term of that examination, every year the occupational physician defines for each worker the types of workings in which he can be employed, essentially in function of the data of the chest radiography. So the sound subject (Aptitude 1) will be able to work everywhere (workings ranked O, A, B, C, D, E) and the serious pneumoconiotics (aptitude 5) will only be author-

ized to work in non dusty working places (rank O); in general they are re-allocated in surface jobs.

We know now that there is a heterogeneity of exposures within the workings. This one could have been in the past at the origin of some cases of early and/or severe pneumoconiosis. Re-allocation must also take into account this heterogeneity. Internal procedures are now in place for a better protection of active miners with slight X-ray changes (score 0/1): their exposures are followed to limit under 5 g the annual cumulative inhaled dose according to their work loads.

Another advantage of personal sampling in coal mines is the ability to detect unsuspected high exposures. The surveys among electromechanics and among workers engaged in heading operations beautifully illustrated this point.

Those different studies carried out with the CIP-10 on the indications of the occupational physician have brought useful contributions to the improvement of the technical and medical prevention of pneumoconiosis in our coal mines. The CIP-10 has been found to be a reliable instrument. Personal sampling is considered useful to identify needs for appropriate control measures and to follow cases at risk.

REFERENCES

1. Amoudru, C. (1987). Les pneumoconioses: dimension actuelle des problèmes Colloque *INSERM*, 155:3-40.
2. Bruyct, B., P. Courbon, and P. Sebastien, (1988). *Personal exposures to respirable dust in French coal mines*. Presented at the international symposium on pneumoconiosis, Shen Yang, China, May 30-June 2, 1988.
3. Courbon, P., R. Wrobel, and J.F. Fabries, (1988). A new individual dust sampler: the CIP-10 *Ann. Occup. Hyg.* 32:1, 129-143.
4. Fabries, J.F., R. Wrobel, and P. Courbon (1987). A compact high-flowrate respirable dust sampler: the CPM3 *Ann. Occup. Hyg.* 31:2, 195-209.
5. Mahieu, B., E. de Surgy, and M. Zitter, (1988). Surveillance des agents suspects de Pneumoconiose par capteur individuel de poussières dans les mines de charbon. Presented at the 20th Journées Nationales de Médecine du Travail Toulouse, France, May 18-21, 1988.

Table V
Personal Dust Sampling with the CIP 10
Heading Workings
Marienau Pit SDS June 1988

EMPLOYMENT	13/6		14/6		16/6		17/6		20/6	
	iTi.		iTi.		iTi.		iTi.		Z3	
Overman		1,63	iTi.	,59	iTi.	(13,0)	iTi.	1,67	Z3	1,12
Haulager	Z3	(3,10)							Z3	(,92)
Haulager							Z3	1,66	Z3	2,51
"Débloqueur"	Z+	1,88	Z+	2,99	Z+	1,83	Z+	1,61	Z+	3,64
Annexes					Z3	2,68	Z2	1,39	Z3	,50
Piper	Z2	1,40	Z3	2,85	Z3	1,40	Z3	1,66	Z2	(1,15)
Piper	Z2	1,14	Z3	1,27	Z3	2,64	Z3	1,61		
"Resserrage bride"					Z3	2,42				
Divers			Z3	1,74	Z3	1,04	Z3	1,00	Z3	2,81
Divers	Z3	1,67			Z3	1,18	Z3	1,85	Z3	1,04
Hewer	Z2	(,08)	Z2	1,48	Z2	1,13	Z2	1,41	Z2	1,56
Hewer	Z2	1,04	Z1	1,96	Z2	,11	Z1	1,41	Z3	4,26
Hewer	Z2	1,06	Z2	2,57	Z2	1,21	Z2	1,06	Z3	4,35
Hewer	Z2	,93	Z2	1,01	Z2	,80	Z2	(,01)	Z3	3,14
Cutterman	Z1	1,58			Z1	2,52			Z3	3,69
Cutterman	Z1	(,18)	Z1	1,75	Z1	1,34	Z1	1,85	Z3	3,10

(*) doubtful values

Results of respirable dust in mg/m³

Activity and localisation of workers during the shift

Table VI
 Personal Dust Sampling with the CIP 10

**HEADING WORKINGS
 MARIENAU PIT SDS JUNE 1988**

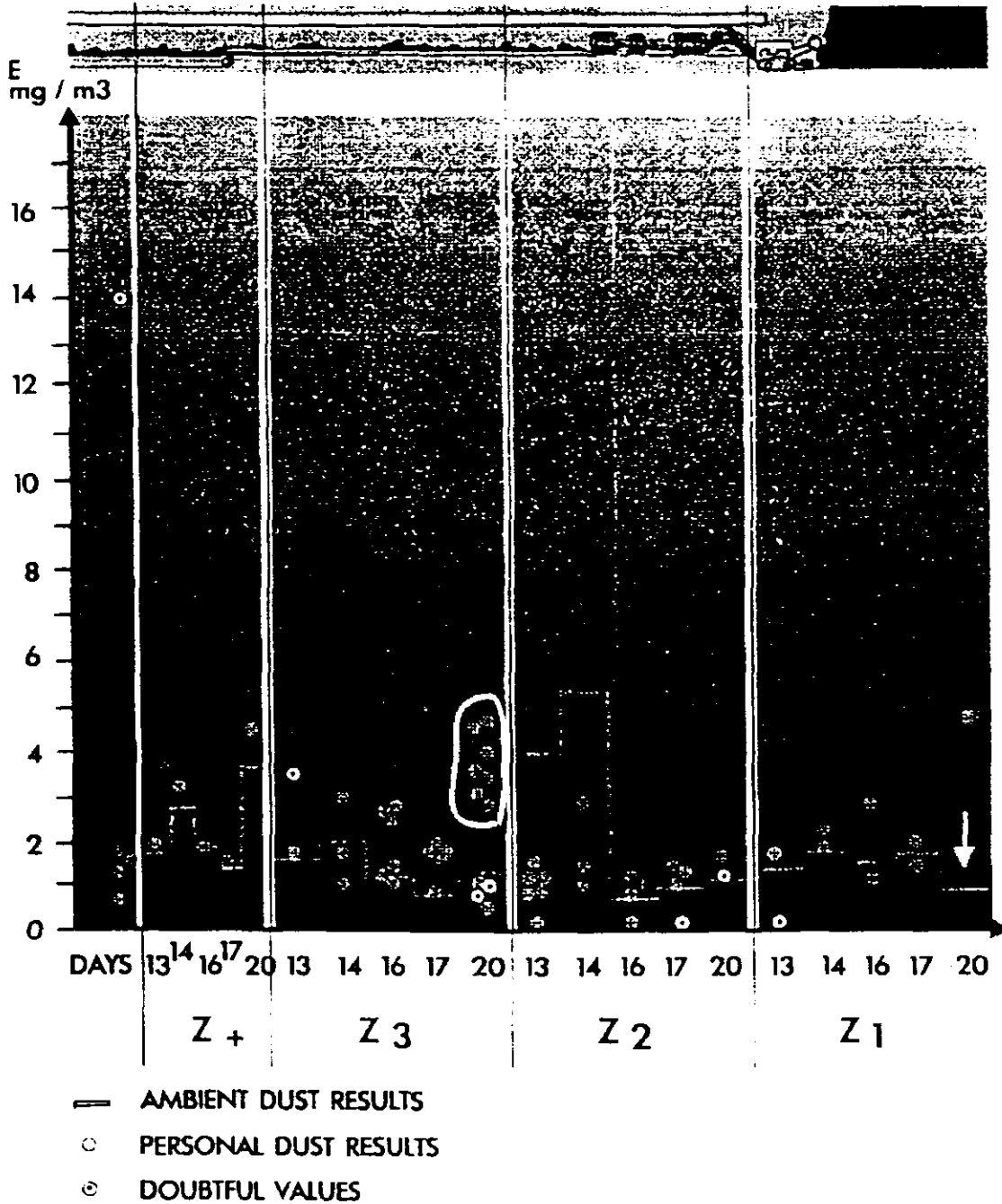

REPARTITION ACCORDING TO THE ZONES AND TO THE DAYS

Table VII
Personal Dust Sampling with the CIP 10

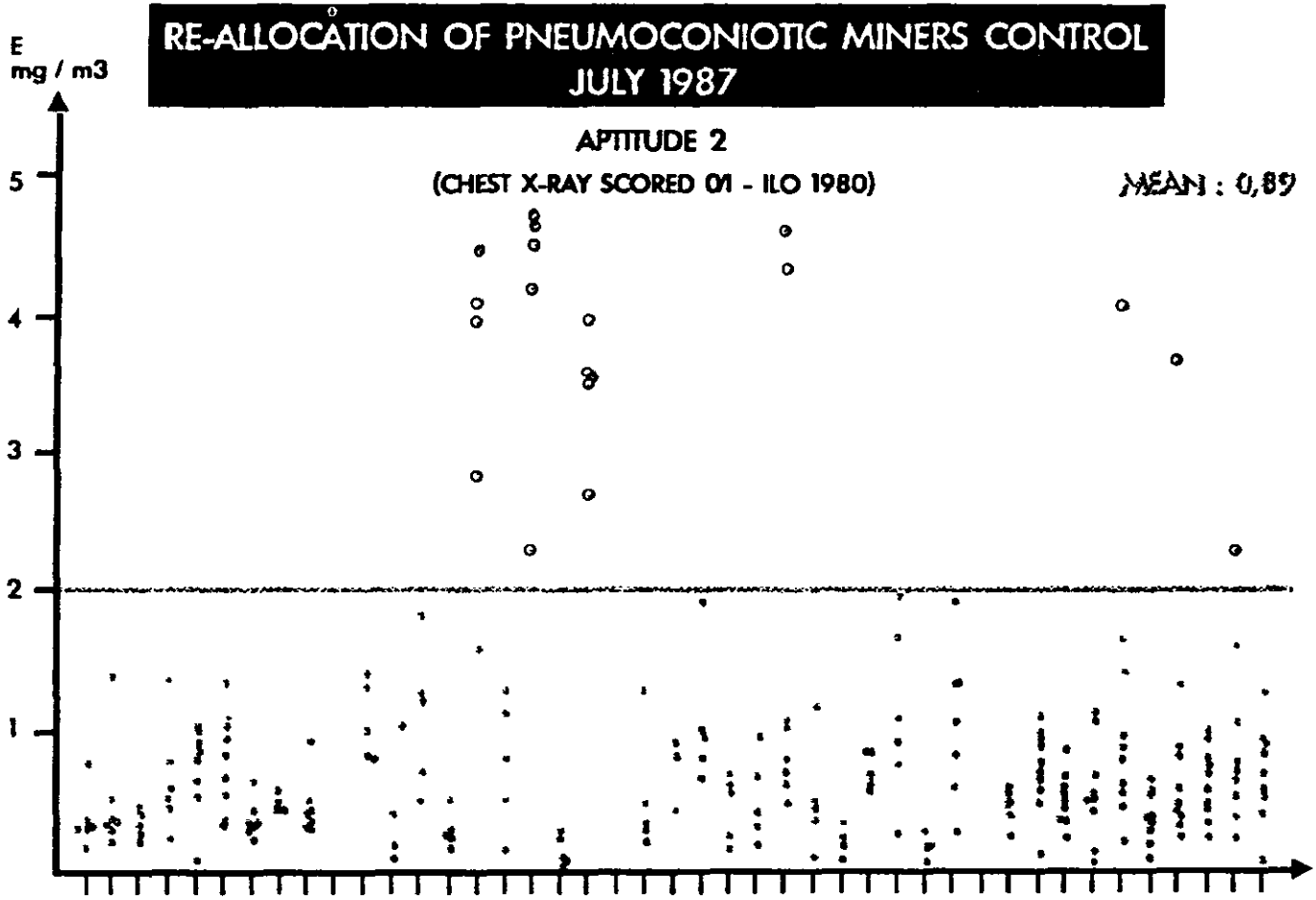
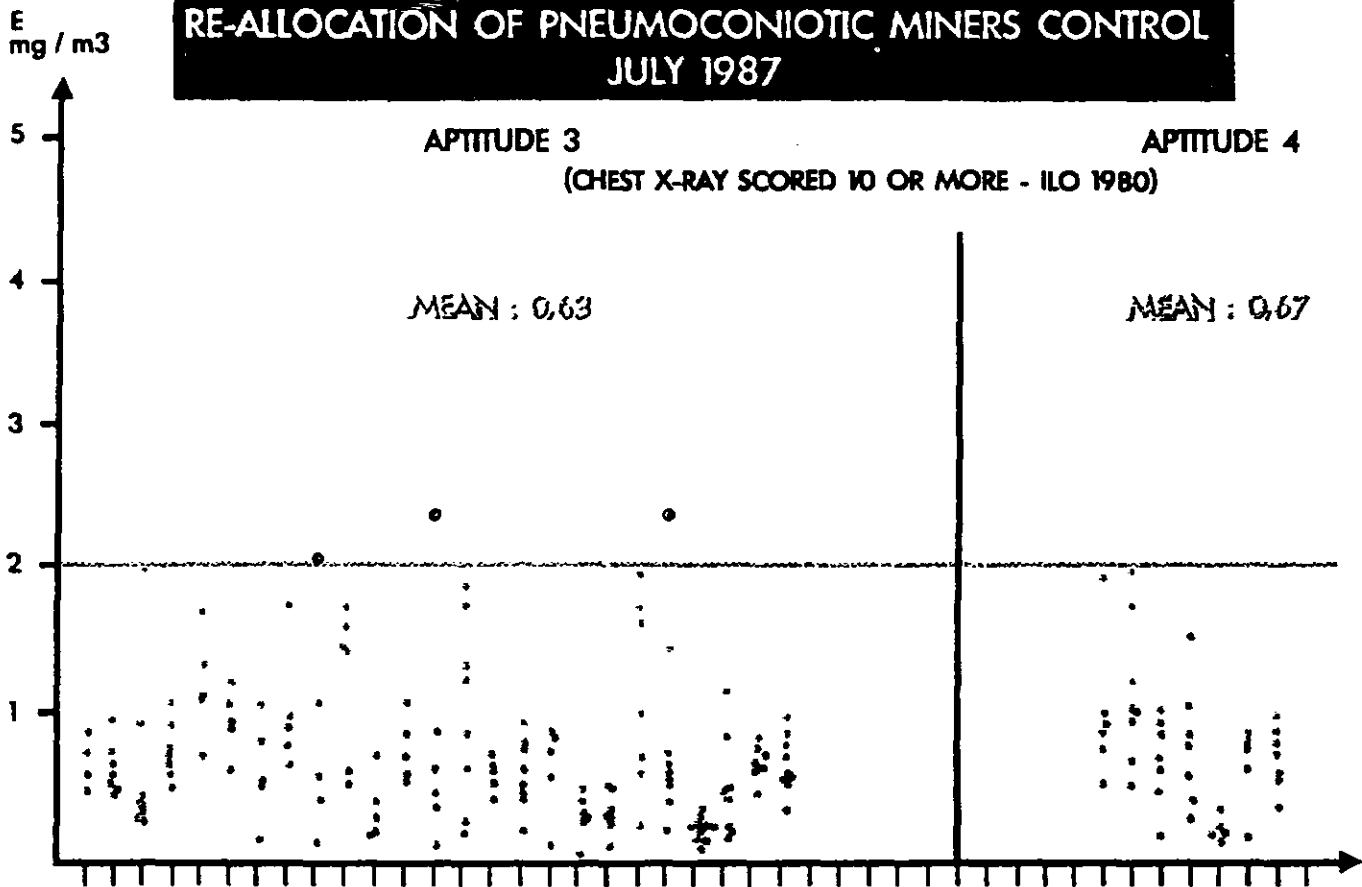

Table VIII
Personal Dust Sampling with the CIP 10

**RE-ALLOCATION OF PNEUMOCONIOTIC MINERS CONTROL
JULY 1987**



PULMONARY FUNCTION CHANGES IN VERMONT GRANITE WORKERS

WILLIAM G.B. GRAHAM • Sheila Weaver •
Taka Ashikaga • David Hemenway • Robert O'Grady

Depts. of Medicine, Biostatistics, and Engineering, University of Vermont and the Vermont State Health Department, Burlington, VT, USA

ABSTRACT

Previous studies have suggested that excessive losses of FVC and FEV₁ were occurring in Vermont granite workers despite the fact that quartz levels existing in the industry were below the current OSHA standards. We re-examined these losses in granite workers over an eight year period, testing the workforce semiannually from 1979 to 1987. All workers, including stone shed, quarry and office were offered forced spirometry using a 10 L. Collins water sealed spirometer. In the peak year of participation (1983), 887 workers out of a total of approximately 1400 were tested. Estimates of longitudinal loss were based on 711 workers who participated in at least 3 of the surveys. The mean age of this group was 42.9 years, and the mean years employed was 19.3 yrs. 21.4% were non-smokers (NS), 34.2% ex-smokers (ES), and 44.4% current smokers (CS). Average annual losses of FVC were $.025 \pm .055$ L. (CS: .032 L.; NS: .014 L.; ES: .024 L.). Average annual losses of FEV₁ were $.036 \pm .040$ L. (CS: .044 L.; NS: .027 L.; ES: .033 L.). Analysis of covariance indicated that losses were related to the initial values for FVC or FEV_{1.0}, height, age, and smoking history. The losses of both FVC and FEV_{1.0} were not correlated with years employed in the granite industry. The losses of pulmonary function were significantly smaller than those estimated previously, which were .070-.080 L in FVC, and .050-.070 in FEV_{1.0}. We conclude that current dust levels in the Vermont granite industry do not accelerate pulmonary function loss.

BACKGROUND

A cross-sectional analysis of pulmonary function loss in Vermont granite workers suggested a small loss in the forced vital capacity (FVC) and FEV₁ due to dust exposure, amounting to 2 ml/year, compared with a 30 ml loss annually due to aging, and a 9 ml loss due to smoking.¹ Although these results were criticized as resulting in a negligible loss over a working lifetime,² a later longitudinal study³ stated that annual losses of FEV₁ were between 50-70 ml, and FVC losses were between 70-80 ml. These studies suggesting excessive pulmonary function loss related to granite dust exposure (average dust-year 523 micrograms/cubic meter, average quartz year of exposure 50 micrograms/cubic meter) were influential in the current NIOSH recommended exposure limit of 50 micrograms/cubic meter for crystalline silica. The operative OSHA limit is 100 micrograms/cubic meter.

In 1981, we published data⁴ concluding that the predicted losses of pulmonary function had not occurred, based on a follow-up study of the same individual workers who had been tested previously. Large increases had occurred in vital capacity values (106 ml year), and there were essentially no losses annually in FEV₁ values. The authors of the previous papers agreed⁵ that the FVC measurements were invalid because of short expiratory times, though the decrements of FEV₁ values continue to be discussed.⁶

This study presents further longitudinal data on pulmonary

function losses in the Vermont granite population. The initial survey, done in 1979, was the basis for our 1981 publication. Follow-up industry-wide surveys were carried out semi-annually to 1987, giving an eight year period of observation. The purpose of the study was to characterize the rate of pulmonary function change and to determine whether exposure to the relatively low levels of granite dust prevailing in the industry significantly affect pulmonary function loss.

METHODS

All employees in the Vermont granite industry, which includes approximately 70 stone sheds and 6 quarries in 5 different communities, were offered forced spirometry semiannually from 1979 to 1987. In 1983 these tests were carried out in conjunction with a chest radiographic survey. Job categories included the various stone shed jobs (polisher, cutter, planer, wire saw, etc.) as well as outdoor quarry workers and office workers. Spirometry was performed on a 10 L. water-sealed Collins spirometer according to recommendations of the Epidemiology Standardization Project.⁷ Values for FVC and FEV₁, ambient temperature, age, years employed in the industry, and smoking history were recorded for each worker. In addition, analysis of total gravimetric dust levels was carried out using personal breathing zone samplers. Data were analyzed using basic univariate analysis, as well as analysis of covariance.

RESULTS

The numbers of workers tested in the semi-annual surveys is given in Table I. The numbers listed for 1979 are artifactually low, since the initial 150 workers tested were excluded because they had been tested on a different instrument which was not precisely calibrated. Subsequent spirometries were performed on the Collins spirometer used by the previous workers from 1970-74. In addition, approximately 100 tracings have been lost and are not available for analysis. Only 173 workers were tested on all five occasions over an eight year period, reflecting the fact that new workers were coming into the work force, others were retiring or were unavailable for testing because of vacation, sick leave or a mobile van at the work place for the first time since 1976. There were 711 workers who were tested 3 times or more. The basic statistics of this group are listed in Table II. Nearly 80% of the workers were either ex-smokers or current smokers; only 21.4% were never smokers. The average number of years in granite was nearly 20.

Longitudinal pulmonary function changes are based on the 711 subjects, both shed and quarry workers, who were tested three or more times. This data is summarized in Table III. Yearly decrements in FEV₁, FVC and FEV₁/FVC × 100 were estimated for each worker as the slope of the fitted least squares regression line for each individual. These slopes were approximately normally distributed and smokers exhibited more function loss than non-smokers and ex-smokers. Overall annual losses were .025 L. for FVC, .036 L. for FEV₁, and 0.37% for the FEV₁/FVC ratio. Non-smokers have the lowest losses, ex-smokers intermediate, and current smokers the highest losses. Within different smoking categories (non-smoker, ex-smoker, and current smoker), there was no difference in losses between exposure categories we presume to be different, i.e. office, shed and quarry workers. Decrements in lung function appear to be similar to those reported in other working populations not exposed to dust in the occupational

environment, and are clearly far lower than the estimates of longitudinal loss reported previously among Vermont granite workers.

To separate out the effects of independent variables (age, value of initial measurement, smoking status and granite working history), we carried out an analysis of covariance. For the FVC and FEV₁, the independent variables of initial FVC, height, age and smoking had a significant effect on pulmonary function changes ($p < .001$ or less), whereas "years in granite," used as an index of granite exposure, had no significant effect ($p = .144$ for FVC and $.151$ for FEV₁).

DISCUSSION

These results indicate that the previous estimates of pulmonary loss in Vermont granite workers were probably in error, and we attribute the conflicting results to the fact that our spirometric measurements were technically rigorous, with careful attention to duration of expiration, calibration of the spirometer, and assuring maximum voluntary effort. Our analysis of dust levels in the stone sheds suggest that no change has occurred in the industry since 1970-78. The mean dust concentration was 601 micrograms/cubic meter, which is quite similar to the results reported previously.⁸ Accepting the quartz levels at 10%, as stated by the previous workers,⁸ the average quartz exposure estimates are 60 micrograms/cubic meter, which is below the current OSHA limit, but above the recommended exposure limit of 50 micrograms/cubic meter proposed by NIOSH. We conclude that current pulmonary function losses are comparable to those seen in non-dust exposed working populations, and that current dust exposures in the granite industry do not contribute to pulmonary function loss. Further, the observed annual losses are approximately half the values reported by previous studies in Vermont granite workers.

Table I
Number of Workers With Data Available
Years Tested

1979	1981	1983	1985	1987	3 or more	all 5
426	613	864	806	661	711	173

Table II
Basic Mean Data of Workers With 3 or More Tests
(All Subjects = 711)

Age in 1983	42.903
Height	68.3
Years in granite	19.336
Mean FEV 1.0., L.	3.687
Mean FVC, L.	4.804
Mean FEV 1.0/FVC	.766

Table III
Mean Annual Longitudinal Losses in Pulmonary Function Parameters
in 711 Workers Tested 3 or More Times

	Smokers N=316	Ex-smokers N=243	Non-smokers N=152	All n=711
FVC, L.	.032	.024	.014	.025
FEV 1.0, L.	.044	.033	.027	.036
FEV 1/FVC x 100	.437	.318	.314	.370

No difference was found in annual losses of FEV 1.0 and FVC between office, quarry and stone shed workers overall or in different smoking categories.

REFERENCES

1. Theriault, G.P., Peters, J.M., Fine, L.J.: Pulmonary Function in Granite Shed Workers of Vermont. *Arch. Environ. Health*. 28:23-27 (1974).
2. Morgan, W.K.C.: The Walrus and the Carpenter of the Silca Criteria Standard. *J. Occup. Med.* 17:782-3 (1975).
3. Musk, A.W., Peter, J.M., Wegman, D.H., Fine, L.J.: Pulmonary Function in Granite Dust Exposure: a Four Year Follow-up. *Am. Rev. Resp. Dis.* 115:769-76 (1977).
4. Graham, W.G.B., O'Grady, R.V., Dubuc, B.: Pulmonary Function Loss in the Vermont Granite Workers. *Am. Rev. Resp. Dis.* 123:25-28 (1981).
5. Wegman, D.H., Eisen, E., Peters, J.M.: Letter to the Editor. *Am. Rev. Resp. Dis.* 128:776-777 (1983).
6. Eisen, E.E., Wegman, D.H., Louis, T.A.: Effects of Selection in a Prospective Study of Forced Expiratory Volume in Vermont Granite Workers. *Am. Rev. Resp. Dis.* 128:587-591 (1983).
7. Ferris, B.G.: Epidemiology Standardization Project. *Am. Rev. Resp. Dis.* 118:1-120 Part 2 (1978).
8. Eisen, E.A., Smith, T.J., Wegman, D.H., Louis, T.S., Froines, J.: Estimation of Long Term Dust Exposures in the Vermont Granite Sheds. *Am. Ind. Hyg. Assoc. J.*: 45:89-94 (1984).

Supported by National Institute for Occupational Safety and Health (5 RO1 OH0135-04).

ARBEITSMEDIZINISCHE VORSORGEUNTERSUCHUNGEN FÜR QUARZFEINSTAUBGEFÄHRDETE BESCHÄFTIGTE IN DER BUNDESREPUBLIK DEUTSCHLAND

SIEGFRIED KNOBLOCH, Dipl.-Ing.

Steinbruchs—Berufisgenossenschaft, Hanover, Federal Republic of Germany

In der Bundesrepublik Deutschland müssen alle Beschäftigten, die an ihrem Arbeitsplatz durch Quarzfeinstaub gefährdet werden, vor Beginn ihrer Tätigkeit und danach in regelmäßigen Abständen arbeitsmedizinisch untersucht werden. Wann kann von einer Gefährdung gesprochen werden? In der Bundesrepublik Deutschland ist für Quarzfeinstaub in der Atemluft der Beschäftigten am Arbeitsplatz eine Schadstoffkonzentration von 0,15 mg/m³ zulässig. Dieser Wert setzt voraus, daß nur gesunde Personen dieser Schadstoffkonzentration ausgesetzt werden. Daraus folgt, daß Beschäftigte schon bei weitaus niedrigeren Schadstoffkonzentrationen arbeitsmedizinisch überwacht werden müssen. In der Bundesrepublik Deutschland ist diese Auslöseschwelle auf die Hälfte des oben genannten Grenzwertes festgelegt worden.

Die arbeitsmedizinischen Untersuchungen müssen vor Ausnahme der Tätigkeit (Erstuntersuchung) und danach in regelmäßigen Abständen (Nachuntersuchungen) wiederholt werden. Die Untersuchungen selbst dürfen nur von besonderen erfahrenen und ermächtigten Ärzten vorgenommen werden. Sofern diese keine kürzeren Zeiträume vorschlagen, erfolgen die Untersuchungen bei quarzfeinstaubgefährdeten Beschäftigten in Abständen von 3 Jahren. Nur wenn und solange der Arzt keine Bedenken erhebt, dürfen die Beschäftigten an ihrer Arbeit weiter nachgehen.

Der Unternehmer hat die Untersuchungstermine zu überwachen, die Untersuchungen zu veranlassen, zu bezahlen und auch für jeden Beschäftigten eine Gesundheitskartei zu führen. In dieser Kartei sind neben den persönlichen Daten festzuhalten:

- Tag der Einstellung und des Ausscheidens,
- Art der Gefährdungsmöglichkeiten,
- Art der Tätigkeit mit Angabe des Zeitpunktes ihres Beginns und ihres Endes,
- Angaben von Zeiten über frühere Tätigkeiten, bei denen eine Gefährdungsmöglichkeit bestand,
- Datum und Ergebnis der arbeitsmedizinischen Vorsorgeuntersuchungen.

Die Steinbruchs-Berufisgenossenschaft, der Träger der

gesetzlichen Unfallversicherung auch für die Steinbrüche, hat seit Jahrzehnten gleichsam als Serviceleistung—für ihre Mitglieder die Terminüberwachung dieser ärztlichen Untersuchungen und die Aufbewahrung der Röntgenaufnahmen und sonstigen Unterlagen übernommen. So sind für alle quarzfeinstaubgefährdeten Beschäftigten lückenlos für die Dauer ihrer Tätigkeit in einem Mitgliedsunternehmen Unterlagen vorhanden, die bei einer beginnenden oder festgestellten Erkrankung für die Beurteilung herangezogen werden können. Dies ist gerade im Hinblick auf die Vielzahl der ganz kleinen Steinbrüche von sehr großer Bedeutung, da diese Betriebe selbst kaum in der Lage sind, die vorgeschriebenen Karteien zu führen und die Unterlagen aufzubewahren.

Im Jahr 1986 hat die Steinbruchs-Berufisgenossenschaft begonnen, alle Daten EDV-mäßig zu erfassen. Seitdem erhält jeder Betrieb, in dem Staubgefährdete versichert sind, 2 Monate vor Ablauf der Untersuchungsfrist eine Benachrichtigung, daß eine weitere Untersuchung vorgenommen werden muß. Dieser Benachrichtigung werden nicht nur die notwendigen Formulare, sondern auch eine Liste der in der näheren Umgebung tätigen und von der Berufisgenossenschaft ermächtigten Ärzte beigelegt. Auf diese Weise hat der Beschäftigte die freie Arztwahl. Nach der Untersuchung werden die Röntgenaufnahmen und die ärztliche Beurteilung der Berufisgenossenschaft zur Aufbewahrung übergeben. Diese legt schließlich alle Unterlagen, die über einen Beschäftigten vorhanden sind, einem besonders ausgebildeten und geübten Arzt zur endgültigen Beurteilung vor. Diese Ärzte besitzen nicht nur eine langjährige Berufserfahrung als Lungenfachärzte, sondern haben sich durch die Vielzahl der Fälle, die ihnen vorgelegt werden, ein besonders umfangreiches Wissen um die Silikose erworben. Jeder dieser Ärzte begutachtet im Jahr etwa 2.000 Personen. Nicht selten kann ein Arzt 10 bis 15 Röntgenaufnahmen desselben Beschäftigten zum Vergleich heranziehen. Dieser Arzt entscheidet auch, ob der Beschäftigte weiterhin seiner bisherigen Tätigkeit nachgehen kann, ob die übliche Untersuchungsfrist von 3 Jahren verkürzt werden muß und ob ein Beschäftigter gegebenenfalls seinen Arbeitsplatz wechseln muß. Etwa 20.000 Beschäftigte, die staubgefährlich tätig sind, werden auf diese Weise überwacht.

Entscheidend für den Grad der Gefährdung eines

Beschäftigten ist neben seinem Gesundheitszustand auch die Höhe der Schadstoffkonzentration in der Atemluft am Arbeitsplatz. Für die Arbeitsmedizin ist es sicherlich von sehr großem Interesse, diese beiden Daten einander gegenüberzustellen bzw. zu verknüpfen, um eine noch verlässlichere Beurteilung der Grenzwerte zu erhalten. Die Steinbruchs-Berufsgenossenschaft ist diesem Ziel schon bereits ein großes Stück nähergekommen. Seit Jahrzehnten wird eine Zielzahl von Staubmessungen am Arbeitsplatz durchgeführt und ausgewertet. Im Jahr 1987 wurde nun mit der Zusammenführung der medizinischen und meßtechnischen Daten begonnen. Dabei wurde zunächst besonderer Wert auf eine möglichst exakte Beschreibung des Arbeitsplatzes und Tätigkeit des einzelnen Beschäftigten gelegt. Bei Wechsel des Betriebes oder Aufnahme einer anderen Tätigkeit werden diese Daten aktualisiert. Auf diese Weise wissen wir schon heute nicht nur, ob ein Beschäftigter gesund ist, sondern seit

wann er einer bestimmten Schadstoffkonzentration ausgesetzt ist. Wir beabsichtigen, dieses Verfahren forzuführen, so daß wir schließlich für diese Beschäftigten über ihr ganzes Arbeitsleben hinweg die entsprechenden Daten haben. Da nicht nur der Arbeitsplatz, sondern auch die Tätigkeit genau beschrieben und verschlüsselt sind, wird es uns künftig auch möglich sein, einzelne Personengruppen daraufhin zu untersuchen, ob sie stärker gefährdet sind als andere.

Der Vollständigkeit halber möchte ich noch erwähnen, daß die Steinbruchs-Berufsgenossenschaft auch einen Röntgenwagen besitzt, der in die Betriebe fährt und dort an Ort und Stelle die Nachuntersuchungen durchführt. Dadurch ist gewährleistet, daß diese Untersuchungen zum vorgeschriebenen Zeitpunkt nahezu lückenlos durchgeführt werden und andererseits den Betrieben beträchtliche Kosten für die Arbeitsunterbrechung erspart bleiben.

PREVALENCE OF RADIOGRAPHIC SMALL LUNG OPACITIES AND PLEURAL ABNORMALITIES IN A REPRESENTATIVE SAMPLE OF ADULT FINNS

A.J. ZITTING • T. Kuusela • O. Impivaara* • J. Maatela* • A. Aromaa*

*Institute of Occupational Health, Helsinki, Finland and Social Insurance Institution, Turku and Helsinki, Finland

ABSTRACT

This study is part of the Mini-Finland Health Survey which was carried out in a sample (n=8000) representative of the Finnish population aged 30 or over. The aim of the study was to investigate the prevalence of radiographic small lung opacities and pleural abnormalities in this population. Of the standard full size radiographs routinely taken, 7095 (89% of the sample) were acceptable for classification purposes. Two radiologists recorded the findings independently according to the ILO (1980) Classification of Radiographs of Pneumoconioses. The prevalences were calculated on the basis of findings agreed on by the two radiologists.

The prevalences of small lung opacities and pleural abnormalities all increased steeply with age and were much higher in men than in women. The prevalences (% , age-adjusted) of the most common findings are given in the table.

	Men	Women
Small opacities (at least category 1)	16.5	10.0
Diffuse pleural thickening	13.8	3.2
Pleural plaques	10.2	2.6
Pleural calcification	6.6	2.3

The divergent prevalences in men and women are probably related to differences in working conditions and smoking habits which are currently subject to further analysis. These population based findings are likely to constitute a useful basis for various reference purposes.

No Paper provided.

OCCUPATIONAL ASTHMA IN MEAT WORKERS EXPOSED TO PROTEOLYTIC ENZYMES

S.K. GALSON • D.I. Bernstein* • J.M. Boiano • J.S. Gallagher* • A.B. Smith

National Institute for Occupational Safety and Health, Cincinnati, Ohio

*University of Cincinnati College of Medicine, Cincinnati, Ohio, USA

ABSTRACT

In January, 1987, work-related shortness of breath and wheezing among workers at a meat portioning facility prompted a request for a NIOSH health hazard evaluation. The facility sprays steaks with spice solutions containing the enzymes papain, bromelain, and ficin. Occupational asthma related to enzyme exposure had not previously been reported in the meat industry.

To identify individuals with symptoms compatible with occupational asthma, we administered a case-finding questionnaire to 376 of 400 current workers. Ninety-six workers with compatible symptoms, and an equal number of non-symptomatic workers, were invited to participate in a set of follow-up examinations, which included a more detailed questionnaire, pulmonary function testing, skin prick testing, and assays for specific IgE to papain. Ninety-six workers participated in the follow-up. Twenty-one (23%) of 91 skin-tested workers reacted to at least one of the purified enzymes. Eight (11%) of 73 participants completing peak-flow measurements had evidence of symptomatic, work-related bronchial lability. Based on the medical studies, we diagnosed 29 workers with possible or definite tenderizer-related occupational asthma. This corresponds to a prevalence of 12% among workers exposed to tenderizers. This study demonstrated that IgE-mediated sensitization to proteolytic enzymes, and tenderizer-related asthma can occur in the meat industry.

No Paper provided.

THE EFFECTS OF AGRICULTURAL DUSTS ON HUMAN HEALTH IN SHANGHAI AREA

SHEN YI-E • Ye Ting-Ting • Dai Gou-Qiang • Zhou Qun-Min • Lu Pei-Lian

Shanghai Medical University

SUMMARY

From 1985 through 1987, the surveys of several kinds of agricultural dusts, including rice, tea, hay and mushroom compost, on human health have been conducted in Shanghai. Totally, 1851 subjects were investigated. There were some disorders related to the exposure to the dusts, including stimulation symptoms on mucous membrane of airway (0.8–63.4% in them), grain fever (5.1–17.5%), hypersensitivity pneumonitis (3.5–5.8%), chronic bronchitis (4.3–17.7%) and some changes of pulmonary function. Some potential etiological agents and mechanisms were studied in the survey. The findings show that these dusts have affected human health.

INTRODUCTION

It is well known that agricultural dusts are harmful to human health.¹ From 1985 through 1987, some field surveys were conducted in the Shanghai area in order to find out their effects on human health and to study some of the potential etiological agents and the mechanisms of the effects.

METHODS AND MATERIALS

Dust Concentrations in Air

The total airborne dust concentrations in workplaces were determined by using the dust collectors of DK-60-2 type and conventional method.

The Amount of Thermoactinomycetes

In order to determine the amount of thermoactinomycetes in air, LWC-1 centrifugal collectors of airborne microorganisms were used to collect microorganisms in various workplaces of cultivating mushrooms. The samples were incubated at 52°C and the colonies were counted every day through the fifth day. Finally, the thermoactinomycetes were identified morphologically.

Subjects

1851 subjects were investigated, including 349 rice processors, 259 tea workers, 746 rice farmers and 497 mushroom farmers. The controls were not exposed to dust in the same area.

Questionnaire and Pulmonary Function Test

The modified questionnaires were applied for interview to the subjects and controls.² The pulmonary function tests were performed by using spirometer of LR-80 type in most of them,

but the tests were done by using Collin's spirometer in mushroom farmers and their controls.

Immunological Test

ELISA was applied to determine the level of IgE in serum from the tea workers and the precipitins in serum were tested in mushroom farmers and their controls.^{3,4}

RESULTS

The Environmental Study

The geometric means of airborne dust concentration in different workplaces have been found to be from 13.2 to 76.9 mg per cubic meter in rice processing mills and from 2.3 to 36.4 mg per cubic meter in the tea mills. In addition, the geometric means of the amount of thermoactinomycetes have been found to be from 1.07×10^4 to 4.39×10^5 CFU per gram of the compost of mushrooms and from 262 to 3276 CFU per cubic meter of air in the workplaces of cultivating mushrooms during the work except the duration of picking mushrooms, but only from 13 to 42 CFU per cubic meter of air in control places.

Response to The Dusts

The prevalence of stimulation symptoms on mucous membrane was 63.4% in rice processors, 53.7% in tea workers, 29.8% in rice farmers and only 0.8% in mushroom farmers. Meanwhile, the prevalence of grain fever was 17.5% in rice processors and 5.1% in rice farmers, being significantly different between them ($P < 0.05$). However, the hypersensitivity pneumonitis (HP) was not found in rice processors. The prevalence of HP (farmer's lung) was 3.5% in rice farmers and the prevalence of mushroom worker's lung, another kind of HP, was 5.8% in mushroom farmers, the latter being significantly higher than the former ($P < 0.05$).

The prevalence of chronic bronchitis in male and female rice processors was the highest (17.7 and 9.9%) of all male and female groups ($P < 0.01$ and $P < 0.05$). The prevalence (in male and female respectively) was 10.6 and 4.3% in rice farmers, 6.7 and 5.5% in mushroom farmers, 2.2 and 1.0% in controls. The prevalence in the tea workers of two mills was 5.6 and 6.0%, respectively.

Pulmonary Function Test

The ratio of the observed to the predicted (O/P) FEV₁, V₇₅, V₅₀ and V₂₅ declined in different groups. The values of FVC, FEV₁, V₅₀ and V₂₅ declined after shift compared with those before the shift in female tea workers significantly and the FEV₁ also declined in female rice processors, but not significantly. It was also shown that the values of FEV₁, FVC and FEV_{25-75%} decreased significantly in the farmers after the season of cultivating mushrooms.

Immunological Test

The average levels of total IgE in serum from the tea workers in the two mills were significantly higher (490.83 and 539.63 IU per ml) than that (290.03 IU per ml) from the controls. Moreover, the prevalence of precipitin reaction against antigens from *T. candidus* 106 and *T. vulgaris* 941 was significantly higher (64.7 and 41.2%) in mushroom farmers than that (6.0 and 8.4%) in controls.

DISCUSSION

The Maximum Allowable Concentrations of airborne rice and tea dusts in the workplace are 10 mg per cubic meter and 3 mg per cubic meter in China, respectively.⁵ In these surveys, most of the samples of airborne dusts had concentrations higher or much higher than the MACs. The rice processors and tea workers were exposed to the high concentration of dust at work every day, which probably was the main cause of the high prevalence of stimulation symptoms on mucous membranes. The rice farmers were only exposed to the rice dust outdoors in the harvest season, so their exposure might not be as serious as the processors and workers. Since the compost of mushrooms was rather wet, there was not so much dust from it, but the aerosol containing microorganisms might generate from it. Therefore, the prevalence of the symptoms in the farmers was not as high as that in the processors and workers.

The prevalence of chronic bronchitis increased in pace with smoking and age.⁶ Although, there was no significant difference of age and smoking habit between male rice processors and other subjects, the prevalence of chronic bronchitis was higher in them than in others. There were almost no women smokers in Shanghai and the average age of female rice processors was younger than that of others, but the prevalence in them was higher than that in others. In addition, the prevalence in every group of subjects was higher than that in controls. Therefore, the chronic bronchitis in the subjects might be related to their exposure to the agricultural dust,

especially to the rice dust in the processing mills.

The prevalence of grain fever in the rice processors was higher than that in rice farmers, which could be related to the fact that exposure to dust was more severe in the former than in the latter. But there was little mouldy rice in the rice processing mills, so the HP was not found in the mills. However, since the rice farmers were not only exposed to the rice dust, but also to mouldy hay dust sometimes, the prevalence of HP (farmer's lung) was 3.5% in them. The mushroom farmers might be exposed to more amounts of thermoactinomycetes in the aerosol from the compost of mushrooms than the rice farmers, thus, the prevalence of HP in them was higher than that in the rice farmers.

Many of the subjects exposed to the agricultural dusts have had some damage of pulmonary function. The changes were obvious in tea workers, which appeared to be obstructive in airway. FEV₁ and FVC decreased, but FEV₁/FVC did not in some mushroom farmers after a cultivating season, which might be consistent with the change of HP.⁷

Mushroom farmers were mainly exposed to thermoactinomycetes like *T. vulgaris*, but not to *M. faeni*, and the precipitins in serum from them were mainly against *T. candidus* and *T. vulgaris* but not against *M. faeni*. So, the main antigens of HP might be from *T. vulgaris* and related taxa, which is probably similar to the findings of the etiological study of farmer's lung in other districts of China.⁸

In addition, the level of IgE in serum was raised in some tea workers who had some respiratory symptoms related to exposure to tea dust, which might imply that some symptoms were possibly related to the mechanism of allergy.⁹

It could be concluded that these agricultural dusts had affected human health in Shanghai. Some preventive measures should be taken such as suppression of dust and mould, personal protective measures, and so on.¹⁰

REFERENCES

1. Parkes, W.R.: *Occupational Lung Disorders*, 2nd Ed., pp. 359-402. Butterworths, London (1982).
2. Lu Pei-lian et al.: Several Links in the Survey of Byssinosis. *Chinese J. Industr. Hyg. Occup. Dis.* 2:120-125 (1984).
3. Zhou Tong et al.: Level of IgE in Human Serum Determined by ELISA. *Chinese J. Microbiol. Immunol.* 1:48-53 (1981).
4. Shen Yi-e et al.: A Primary Study of Causative Agents of Farmer's Lung in Dafeng County. *Chinese J. Industr. Hyg. Occup. Dis.* 5:377 (1987).
5. Lu Pei-lian and Gu Xing-yuan: *Preventive Medicine*, 1st Ed., pp. 275-277. Shanghai First Medical College, Shanghai (1984).
6. Guo De-long: Smoking and Health. *Chinese J. Tuberculosis Respir. Dis.* 3:121-122 (1980).
7. Shen Yi-e and Lu Pei-lian: Some Views on the Diagnostic Criterion of Farmer's Lung. *Chinese J. Industr. Hyg. Occup. Dis.* 5:110 (1987).
8. Lu Yun-yu et al.: Studies on Pathogens of Farmer's Lung in Jiangsu—Isolation and Classification of Thermophilic Actinomycetes. *Acta Microbiologica Sinica* 25:351-355 (1985).
9. Zuskin, E. et al.: Immunological and Respiratory Changes in Tea Workers. *Int. Arch. Occup. Environ. Health.* 56:57-65 (1985).
10. Tao Bing-gen et al.: An Epidemiological Study on Farmer's Lung in Dafeng County, Jiangsu Province. *Chinese J. Industr. Hyg. Occup. Dis.* 2:34-38 (1984).

OCCUPATION INDUCED PULMONARY DISEASE IN A WAFER BOARD MANUFACTURING PLANT, COLORADO

T.R. HALES • P. J. Seligman • B. J. Daniels

National Institute for Occupational Safety and Health (NIOSH), Cincinnati, Ohio, USA

ABSTRACT

In December 1986 the Colorado Department of Health requested assistance from the National Institute for Occupational Safety and Health in evaluating a cluster of asthma cases among employees of a wafer board manufacturing plant. The plant reduces aspen logs to thin wafers, which are then pressed into rigid wafer-boards using MDI (4,4-diphenylmethane diisocyanate) as the binding agent. A cross-sectional survey of 97 current employees and directed review of 93 former employees identified 13 cases of disease for an overall attack rate of 6.7%. The attack rate among current employees was 3%, while the attack rate among former employees was 11%. Personal air samples for MDI were within NIOSH's standard (5 ppb), suggesting that our cases represent sensitized individuals. To identify risk factors associated with disease a case control study was undertaken. No association was found between family or personal history of asthma, eczema, hayfever, smoking, or job title. Given our inability to find any predictive pre-employment screening tests, nor identify any particular area or job title with MDI exposure, surveillance of the current workforce for early MDI sensitization is very important. Symptom questionnaires, peak expiratory flow readings, MDI-ELISA and RAST tests, could all be used.

No Paper provided.

BYSSINOSIS: RESPIRATORY PROBLEMS AMONG COTTON TEXTILE MILL WORKERS IN ETHIOPIA

WOLDE YOHANNES MENTESINOT,* M.D., MSc • Yves Bergevin,† MDCM, MSc • Amani Yacob Mgeni,‡ M.D., DPH, MSc

*Department of Community Health, Faculty of Medicine, Addis Ababa University and Ministry of Health, Addis Ababa, People's Democratic Republic of Ethiopia

†Department of Epidemiology and Biostatistics, McGill University, Montreal, Canada and McGill-Ethiopia Community Health Project, Addis Ababa, People's Democratic Republic of Ethiopia

‡Representative Office, World Health Organization, Addis Ababa, People's Democratic Republic of Ethiopia

INTRODUCTION

Although occupational lung disorder caused by inhalation of cotton dust is a continuing problem and byssinosis is now known to occur worldwide, cotton production and consumption has expanded rapidly in developing countries. The People's Democratic Republic of Ethiopia being one of the cotton producers and consumers countries in Africa, started expanding its textile industries since the last decade and the number of its workers in cotton processing continues to grow annually.

Lots of studies in cotton mills were done and reported from many developed nations and also few reports regarding respiratory problems have been documented from developing countries like Egypt,¹ Sudan,² Tanzania,³ and Hong Kong,⁴ but there is no article published concerning the problems caused by cotton dust in Ethiopia. Thus, this paper represents the first epidemiological study of the textile industry in Ethiopia using diagnostic criterion similar to those which are applied in developed countries, such as the United States of America and Great Britain.

A few studies of cotton textile workers have looked into the prevalence of respiratory symptoms and lung function compared with those of control subjects.^{5,6,7,8} There is also a limited number of studies that have reviewed lung function in cotton textile workers with and without byssinosis or bronchitis.^{9,10,11} This study investigated the prevalence of byssinosis and other respiratory problems among workers exposed to cotton dust in a textile mill in Ethiopia and also attempted to explore determinants by considering workers exposed to cotton dust in the textile mill with respiratory tract diseases as case study group and without respiratory tract disease as control group.

This cotton textile mill was established in the early 1960s and a daily eight hourly system is operating continuously for the whole week, while intermittently providing a "day-off" for each worker to rest. In spite of the attempt to retrofit current ventilation systems in the early 1980s, plant officials stated that the dusty environment remained unchanged since the early 1960s.¹²

MATERIAL AND METHODS

Population

This study included a group of randomly selected 595 workers (322 male and 273 female) representing 40.5% of workers involved in dusty operations in the blowing, carding, drawing, simplex, ringframe, preparatory and weaving sections of a cotton textile mill in Bahir Dar, Ethiopia.

Environmental Assessment

The concentration of airborne dust in the breathing zone was determined with the casella personal dust sampler and the sampling rate was set to 0.2 l/min. The concentration of airborne dust in the general environment was concurrently monitored with an Anderson dust sampler fitted with a vertical elutriator (General Metal Works Inc.) that was set up at a height of 1.5m at selected positions and samples were drawn at a rate of 7.4l/min. Multiple area samples were taken and the duration of sampling ranged between 8-10 hours (mean 8.7 hours). All samples were collected on What man glass fibre GF/A with 3.7 cm diameter and weighing was done on a calibrated analytical balance before and after sample collection after equilibrating filters in the laboratory for 24 hours.

Interviews and Physical Examination

A modified version of the British Medical Research Council Questionnaire was filled out and each worker was fully examined with emphasis being laid on signs and symptoms suggestive of respiratory diseases. All workers were blindly interviewed and examined by one trained physician. The stages of byssinosis were defined according to the clinical grades suggested by Schilling et al.¹³ Subjects were also diagnosed as having other respiratory diseases based on previously stated criteria.^{14,15,16} Subjects who gave confirmed past history of respiratory diseases were also considered in this study.

Pulmonary Function Test

Subjects' forced vital capacity (FVC) and forced expiratory volume in one second (FEV₁) were measured under the direction of a technician using a multipurpose spirometer.

Function testings were carried out on each worker on the first day of the shift after at least one day absence from work and repeated at the end of the same shift. Five expiratory efforts were recorded and the mean of the two highest values was used to estimate the FEV₁ and FVC. All volumes were adjusted to body temperature and pressure saturated with water vapour (BTPS). The preshift FEV₁ values were compared with the expected normal values of Cherniack and Rater.¹⁷

For all statistical tests, P less than 0.05 was considered significant.

RESULTS

Population

All the 595 workers in the study voluntarily underwent interview, physical examination and pulmonary function testing. Non-reproducible function tests of 32 subjects were excluded only from pulmonary function test analysis. There were only 14 smokers and 4 ex-smokers, all male. Over 95% of the cotton workers had not changed jobs or their sections during the course of their employment.

Environmental Assessment

The concentrations of airborne cotton dust are shown in Table I. The highest concentration of cotton dust was recorded in the blowing and carding sections, whereas the lowest was recorded in the weaving and preparatory sections. The amount of dust generated in the blowing and carding operations was high and more than two fold compared to other operations ($P < 0.005$). The mean dust concentration and the mean time-weighted dust concentration were much higher ($P < 0.001$) in the case study group than in the control group.

Respiratory Conditions

The prevalence of byssinosis and other respiratory tract diseases is summarized in Table II and Figure 1. The prevalences of byssinosis, chronic bronchitis and bronchial asthma were very high ($P < 0.001$) among blowers and carders in comparison to those in other sections. The overall prevalence of hay fever (28.3%) was the highest of all the respiratory problems in the textile mill. Generally, the prevalence of byssinosis, chronic bronchitis and bronchial asthma showed a significant increase with the duration of exposure to cotton dust in the textile mill (Table III). No significant difference was observed in the prevalence of byssinosis between smoking and non-smoking workers, otherwise, the effect of smoking on the prevalence of chronic bronchitis was significant (Table IV). In general, 48.1% of the study population had one or more respiratory tract problems while the remaining 51.9% had neither symptoms and signs nor gave past histories of respiratory tract diseases.

We regrouped the study population in two strata based on the frequency distribution of the time-weighted elutriated dust concentration as those with a high and low cumulative dust exposure and cross tabulated, assuming the present dust levels were more or less similar to the past ones.

The estimated relative risks of developing byssinosis and other

respiratory problems in high cumulative cotton dust exposure were statistically significant when compared to low cumulative cotton dust exposure (Table V). Also the estimated relative risk of manifesting symptoms of respiratory impairment was significant in those exposed to high cumulative cotton dust and developed respiratory tract problems when compared with those exposed to low cumulative cotton dust (Table VI).

Pulmonary Function Test Analysis

A statistically significant ($P < 0.001$) across-shift decrements in FEV₁ and FVC and also a decrease in the percentage predicted FEV₁ were noted in the case study group when compared with the control group. There was a significant reduction in FEV₁ ($P < 0.001$) at the end of the shift, more than 10% and/or 20% among byssinotics when compared with the controls (Figure 2). Also a significant increase in percentage reduction in FEV₁ was noted with an increase in byssinosis grade. The chronic changes in FEV₁ among exposed workers were further analysed according to Bouhuys et al.¹⁸ While 24% of byssinotics developed FEV₁ moderate to severe chronic changes ($P < 0.001$), only 1% of the non-respiratory tract disease group (controls) showed similar changes (Table VII).

Generally, the regression analysis results shown in Tables VIII and IX indicate statistically significant dose-response relationship between respiratory problems and pulmonary function test results at one hand and current, cumulative and length of exposure to cotton dust at the other.

DISCUSSION

The results of our study showed that the concentrations of airborne cotton dust in the different sections of the surveyed textile mill were very high, with concentrations greatly in excess (nearly 4 to 17 tons) of 0.2 mg/m³ of dust.¹⁹ This was in accordance with reports on other cotton mills.^{2,6,20} Also the dust collected at the early stage of yarn production was very high and this was similar to those reported by others.^{2,21,22}

The high prevalence of byssinosis in the blowing and carding processes is similar to those reported by other investigators.^{2,23,24} The high prevalence of byssinosis in drawing, simplex and ringframe spinners may be due to the fact that the level of cotton dust was still high in these sections.

In spite of the controversy surrounding the relationship between the prevalence of byssinosis and the duration of exposure, our study showed a significant increase in the prevalence of byssinosis with duration of exposure. The same relationship had also been observed in Sudan and Egypt.^{2,20,21} The progression in the stages of byssinosis in relation to the duration of exposure observed in our finding support previously reported conclusions that the different grades of byssinosis succeed each other in diseased subjects.^{2,20,21} Our results also showed that there was a significant association between the prevalence of byssinosis and time-weighted dust concentration. This is in agreement with Fox et al.²⁵ Our results showed that smoking had no significant relationship with the prevalence of byssinosis, probably because of the small number of smokers in our study. Hence due to this small number, there may be a risk of a type II error.

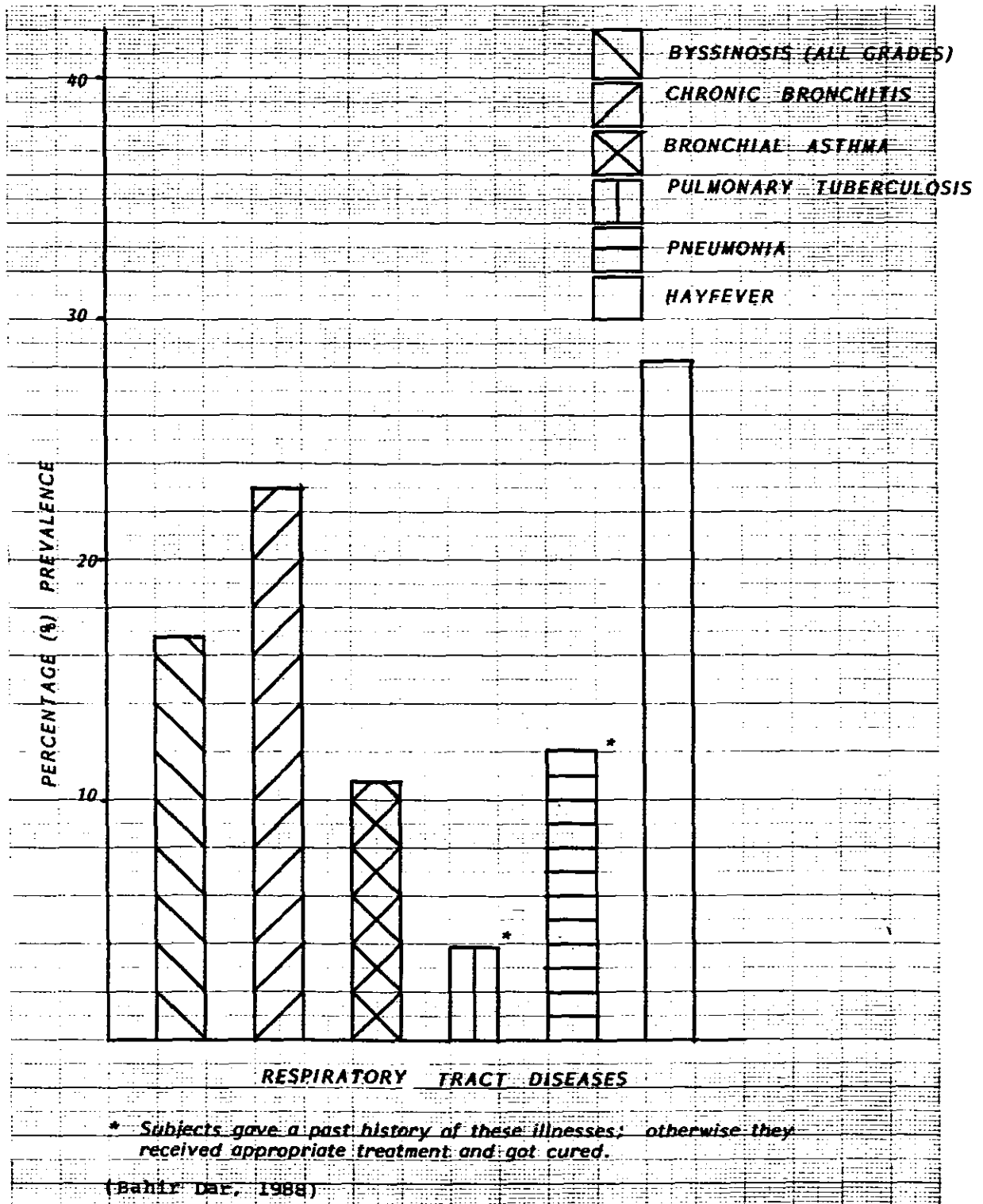

Figure 1. Prevalence of respiratory tract diseases among exposed workers.

Table I
The Concentration of Airborne Cotton Dust in Study Sections
by Area Sampling and Personal Sampling (Mean \pm SD)

Section	Number of Samples	Area Sampling	Personal Sampling
		"Inhalable" Dust mg/m ³	"Respirable" Dust mg/m ³
Blowing (1)	14	3.52 \pm 0.98	3.83 \pm 1.06
Carding (2)	18	3.21 \pm 1.09	3.58 \pm 1.07
Drawing (3)	11	1.62 \pm 0.44	1.93 \pm 0.23
Simplex (4)	11	1.29 \pm 0.32	1.72 \pm 0.26
Ringframe (5)	21	1.19 \pm 0.49	1.57 \pm 0.55
Preparatory (6)	12	0.92 \pm 0.23	1.21 \pm 0.33
Weaving (7)	25	0.86 \pm 0.35	1.03 \pm 0.37

Level of Significance

$IV_{S2} \quad P > 0.05 \quad IV_{S2} \quad P > 0.05$

$IV_{S3} - 7P < 0.0005 \quad IV_{S3} - 7P < 0.0005$

$2V_{S3} - 7P < 0.005 \quad 2V_{S3} - 7P < 0.0005$

(Bahir Dar, 1988)

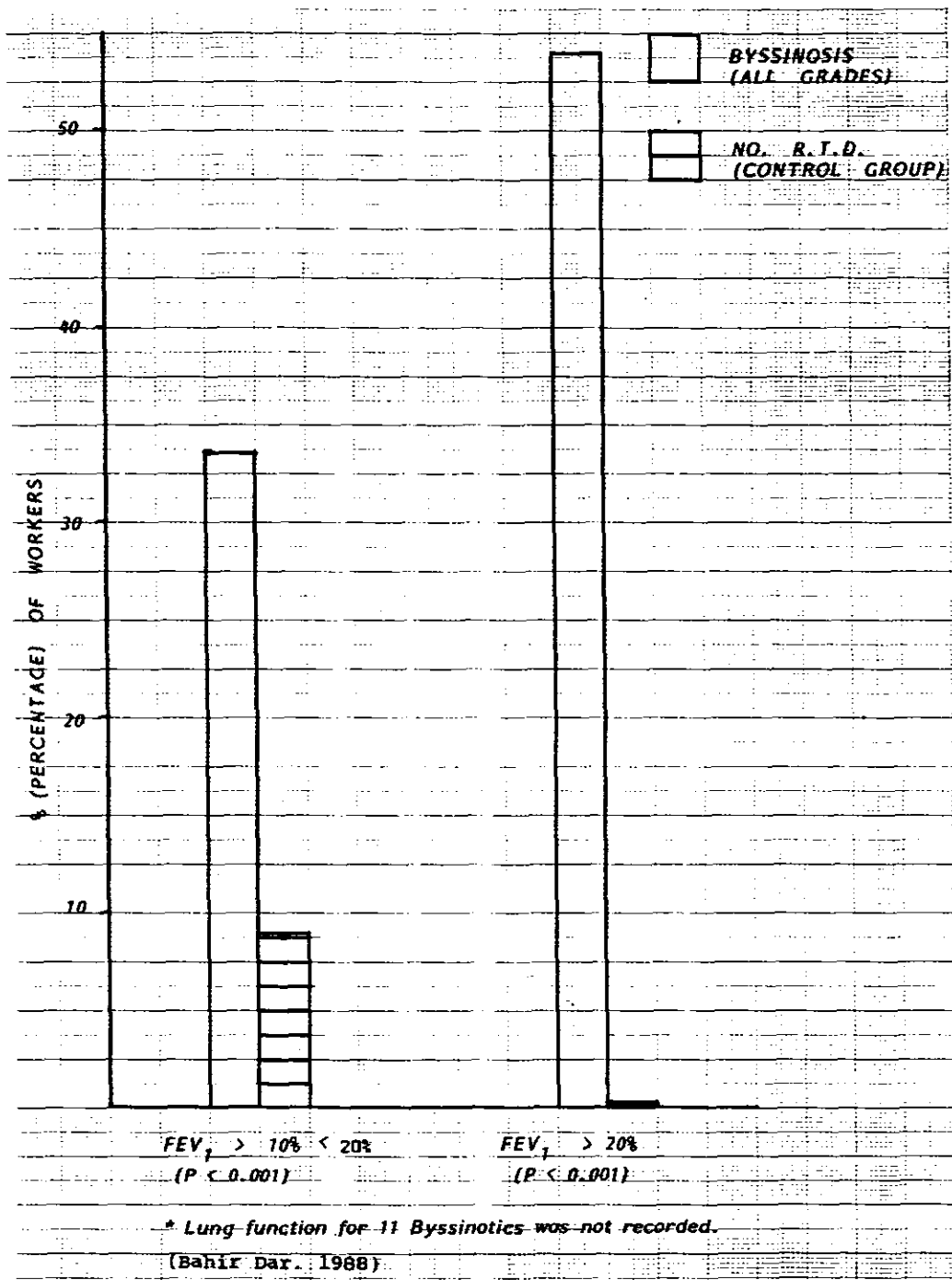

Figure 2. Percent reduction in FEV₁ in examined workers during the first working day after absence from work.*

Table II
The Prevalence of Respiratory Diseases Among Exposed Workers
Mean Age and Duration of Exposure

SECTION	Number Examined	Age (Years) Mean \pm SD	Duration of Exposure (Months) MEAN \pm SD	BYSSINOSIS NO. (%)				Chronic Bronchitis No. (%)	Bronchial Asthma No. (%)
				G ₁	G _I	G _{II}	Total		
Blowing(1)	44	41.3 \pm 7.3	201.9 \pm 87.2	3(7)	7(15.9)	9(20.5)	19(43.2)*	21(47.7)*	9(20.5)*
Carding (2)	40	41.5 \pm 6.9	200.7 \pm 74.8	-	2(5)	13(32.5)	15(37.5)*	18(45)*	5(12.5)
Drawing (3)	25	39.9 \pm 6.6	239.6 \pm 68.5	3(12)	1(4)	2(8)	6(24)	8(32)	3(12)
Simplex (4)	42	40 \pm 6.8	235.3 \pm 69.4	3(7)	3(7.1)	4(9.5)	10(23.8)	10(23.8)	3(7.1)
Ringframe(5)	174	37.5 \pm 6.5	233.1 \pm 73.2	12(6.9)	9(5.2)	9(5.2)	30(17.2)	32(20.7)	17(9.8)
Preparatory(6)	128	37.1 \pm 5.8	222.9 \pm 71.5	10(8)	-	4(3.1)	14(10.9)	23(18.0)	15(11.7)
Weaving (7)	142	39 \pm 4.6	238.7 \pm 67	3(2.1)	2(1.4)	1(0.7)	6(4.2)	25(17.6)	12(8.5)
TOTAL	595	38 \pm 6.9	218.3 \pm 79.5	34(5.7)	24(4)	42(7.1)	100(16.8)	137(23)	65(10.8)

* $P < 0.001$
(Bahir Dar, 1988)

Table III
Duration of Exposure and the Prevalence of Respiratory Diseases

Duration of Exposure (Years)	Number Examined	BYSSINOSIS NO (%)				Chronic Bronchitis No. (%)	Bronchial Asthma No. (%)
		G ₁	G _I	G _{II}	TOTAL		
< 10 Years	105	2 (1.9)	4(3.8)	-	6(5.7)	17(16.2)	2 (1.9)
10 - 20 Years	208	11 (5.3)	6(2.9)	8 (3.8)	25(12)	43(20.7)	12 (5.8)
> 20 Years	282	21(7.4)	14 (5)	34(12.1)	69(24.5)	77(27.3)	50(17.7)
T O T A L	595	34(5.7)	24(4)	42(7.1)	100(16.8)	137 (23)	64(10.8)
					$P < 0.001$	$P < 0.05$	$P < 0.001$

Table IV
The Effect of Smoking on the Prevalence of Byssinosis

GROUP	NUMBER EXAMINED	DURATION EXPOSURE (YEARS) (MEAN ± SD)+	B Y S S I N O S I S NO. (%)				CHRONIC BRONCHITIS No. (%)	BRONCHIAL ASTHMA NO. (%)
			GI	GI	GII	TOTAL		
Smokers	14	17.1 ± 8.2	1 (7.1)	1(7.1)	1(7.1)	3(21.4)*	9(64.3)**	-
Non or Ex-smokers	581	18.2 ± 6.6	33(5.7)	23 (4)	41 (7)	97(16.7)	128 (22)	64 (11)
+N.S. (P> 0.05)					* N.S.		** P<0.001	

(Bahir Dar, 1988)

Table V
Comparison of Cases (Byssinosis and Other Respiratory Tract Diseases Groups) with Control (No Respiratory Tract Disease Group) Using Time Weighted Dust Concentration

G R O U P	High Time Weighted Dust Concentration (366.72-1182.72) (mg months/m ³)		Low Time Weighted Dust Concentration (183.36 -206.4) (mg months/m ³)		χ ² (1d.f.)	P-Value	Odds Ratio	95% Confidence Interval (C.I.)
	NO.	%	NO.	%				
Control								
. No R.T.D	78	(38.8)	123	(61.2)				
Cases								
. All R.T.D	122	(63.2)	71	(36.8)	23.46	P<0.001	2.71	(2.48, 2.94)
. Byssinosis	69	(93.2)	5	(6.8)	64.41	P<0.001	21.76	(8.41, 56.26)
. Chronic Bronchitis	67	(69.8)	29	(30.2)	24.96	P<0.001	3.64	(2.16, 6.11)
. Bronchial Asthma	29	(78.4)	8	(21.6)	19.79	P<0.001	5.72	(2.48, 13.07)
. Plumonary Tuberculosis	12	(75)	4	(25)	7.99	P<0.01	4.73	(1.46, 15.18)
. Pneumonia	32	(61.5)	20	(38.5)	8.68	P<0.01	2.52	(1.34, 4.71)
. Hay Fever	67	(61.5)	42	(38.5)	14.59	P<0.001	2.52	(1.55, 4.06)

(Bahir Dar, 1988)

Although previous investigators^{7,25} found that the prevalence of chronic bronchitis is not related to dust concentrations, the significant relationship observed in our study is in agreement with those of El Karim² and Merchant et al.²⁶ Although cigarette smoking is the single most important etiologic factor of chronic bronchitis, occupational and environmental exposures are now receiving more attention as also supported by our finding.

Our finding also showed that bronchial asthma was high among the blowers and had a significant relationship with the cumulative cotton dust exposure. A majority of the asthmatics developed the problem after they had worked for several years in this textile mill. Even though a majority of the asthmatics gave negative family histories of allergy, 34.4% had had intermittent symptoms of rhinitis which was mostly seasonal.

Our finding showed that there was no significant relationship between hay fever and current dust exposure but the relationship with longevity in the cotton textile mill and cumulative cotton dust exposure was significant. This finding probably might be due to the reason that an allergic reaction does not occur on first exposure. The latent interval during which sensitization occurs varies from a few weeks to many years. When hay fever, for that matter even asthma, first develops some years after an employee entered an industry, it is easy to understand that an occupational origin may be completely overlooked. In our study a majority of hay fever cases developed the symptom complex after many years of longevity in the textile mill.

Even though there is some evidence that byssinosis is not more

prevalent among atopic than non-atopic workers,²⁷ our finding revealed that the majority of byssinotics (55%) had clear-cut characteristic symptom complex of hay fever (allergic rhinitis). Added to this, the prevalence of hay fever was very high in our study population. In agreement to this and as described by Jones et al.,²⁸ atopy might be an important risk factor in the development of byssinosis and indicates the importance of identifying atopic workers.

Our study demonstrated that byssinotics had significantly greater acute decrements in FEV₁ throughout a workshift than those without respiratory tract diseases, supporting the findings of earlier investigators.^{9,29,30} The cotton exposed workers with byssinosis had also a significantly lower percent-predicted FEV₁ than those in the group without respiratory tract disease (control), being in agreement with previous investigators.^{2,8,9,31,32,33}

In conclusion, our findings suggest that there may be high estimated risk of developing respiratory diseases and impairment as well as leading workers to absence from work due to illness in high time-weighted dust concentration than in low time-weighted dust concentration signifying the extent of the occupational health hazard that calls for due consideration by all those concerned. Also an immunological dysfunction such as atopy, may be a risk factor in the development of cotton dust induced respiratory disease. Thus keeping in mind cotton dust has diverse content as described by many investigators, the extent of association between exposure to cotton dust and hay fever and also the extent of development of byssinosis and other respiratory problems among atopic and non-atopic workers should be investigated and analysed in depth.

Table VI

Comparison of Symptoms of Respiratory Impairment and Period of Absence from Work Due to Sickness in Those Cases with High and Low Time Weighted Dust Concentration with "No Respiratory Tract Disease" Group as Control

G R O U P	High Time Weighted Dust Concentration (366.72 - 1182.72) (mg months./ m ³)		Low Time Weighted Dust Concentration (183.36 - 206.4) (mg months/m ³)		X ² (1 d.f.)	P-Value	ODDS R a t i o	95% Confidence Interval (C.I.)
	No.	(%)	No.	(%)				
	Control							
÷ No R.T.D	78	(38.8)	123	(61.2)				
Cases								
. Sob Hill*	112	(70)	48	(30)	34.77	p<0.001	3.68	(2.36, 5.7)
. Sob Level **	81	(80.2)	20	(19.8)	46.18	p<0.001	6.39	(3.6, 11.25)
. Sob Pace ***	29	(87.9)	4	(12.1)	27.5	p<0.001	11.43	(6.62, 19.89)
. Sick Week	64	(71.9)	25	(28.1)	27.05	p<0.001	4.04	(2.36, 6.96)
. More Illness	32	(69.6)	14	(30.4)	13.77	p<0.001	3.6	(1.8, 7.17)

(bahir Dar, 1988)

* Shortness of breath while walking up a slight hill
 ** Shortness of breath while walking on a level ground with persons of the same age
 *** Shortness of breath even when walking at own pace.

Table VII
Chronic Changes in FEV₁ among Exposed Workers

Byssinosis	Number Examined	FEV ₁ C H R O N I C C H A N G E S *					
		No. Change ≥ 80% of Pre- dicted Value		Moderate 60-80% of Predicted Value		Severe ≤ 50% of Predicted Value.	
		No.	%	No.	%	No.	%
<hr/>							
No. R. T. D							
Controls	309(51.93)	210	67.96	96	31.07	3	.97
Byssinosis							
Grade ½	34(5.71)	20	58.82	13	38.24	1	2.94
Grade I	24(4.03)	11	45.83	8	33.33	5	20.83
Grade II	42(7.06)	9	21.43	15	35.71	18	42.86
All Grades	100(16.81)	40	40	36	36	24	24**
Total	595(100)	376	63.19	191	32.1	28	4.71

Lung function was not recorded for 32 subjects.

* Graded according to Bouhuys et al. (1970)

** P < 0.001

(Bahir Dar, 1988)

Table VIII
Regression Coefficients for Time Weighted Cotton Dust
Concentration, Age, Height and Weight in Byssinosis and
Pulmonary Function Models

	VARIABLE	MALE (N = 323)	FEMALE (n= 272)	ALL WORKERS (N = 597)
Byssinosis*	Total Dust	0.002 [±]	0.002 [±]	0.002 [±]
	Age	0.059	0.104*	0.079
	Weight	-0.012 [±]	-0.109*	- 0.01 [±]
	Height	-0.01	0.002	0.033
FEV ₁ **	Total Dust	0.221 [±]	0.167 [±]	0.207 [±]
	Age	0.095	0.009	0.06
	Weight	-0.07	-0.017	- 0.045
	Height	-0.018	-0.044	- 0.011
FVC***	Total Dust	0.085 [±]	0.044 [±]	0.061 [±]
	Age	0.115	0.015	1.088 [±]
	Weight	-1.029+	0.033	- 0.019
	Height	0.039	0.072	0.048

Lung function was not recorded for 32 subjects.

± p < 0.001

+ p < 0.05

N.B. For differences between sexes, after allowance for age, height and weight.

*MALE F (1 and 320 d.f.) = 98.96	P < 0.000 and R ² = 0.23621
*FEMALE F (1 and 271 d.f.) = 44.96	P < 0.000 and R ² = 0.14229
** MALE F (1 and 302 d.f.) = 52.53	P < 0.000 and R ² = 0.14100
** FEMALE F (1 and 257 d.f.) = 17.2	P < 0.0000 and R ² = 0.05967
*** MALE F (1 and 302 d.f.) = 22.14	P < 0.000 and R ² = 0.06471
*** FEMALE F (1 and 257 d.f.) = 4.05	P < 0.0452 and R ² = 0.01472

(Bahir Dar, 1988)

Table IX
 Regression Coefficients for Period of Exposure,
 Current Cotton Dust Exposure and Cumulative Cotton Dust
 Exposure in Byssinosis, Chronic Bronchitis, Bronchial Asthma,
 Pulmonary Tuberculosis, Pneumonia, Hay Fever and Pulmonary Function Models

Symptom	Period of Exposure (Months)	Current Exposure Cotton Dust Concentration (mg/m ³)	Cumulative Exposure Cotton Dust Concentration (mg months/m ³)
Byssinosis	0.002 [#]	0.308 [#]	0.001 [#]
Chronic Bronchitis	0.042 ^{**}	0.065	3.76 E-04 [#]
Bronchial Asthma	0.066 [*]	0.117	0.075 ^{**}
Pulmonary Tuberculosis	8.65 E-04	0.011	7.26 E-05 [*]
Pneumonia	0.046	0.055	1.84 E-04 ⁺
Hay Fever	7.14 E-04 ⁺	0.066	0.077 ^{**}
FEV ₁	0.427	0.054	0.154 ^{##}
FVC	0.005	0.006	0.06 [#]

P < 0.001

+ P < 0.01

* P < 0.05

** P < 0.05 in one tail test (this is considered since the hypothesis from the outset was unidirectional)

N.B. General Models: $Symptom = \beta_0 + \beta_1 (age) + \beta_2 (Sex) + \beta_3 (height) + \beta_4 (weight) + \beta_5 (exposure) \times \epsilon$

(Bahir Dar 1988)

REFERENCES

1. El. Batawi, M.A.: Byssinosis in the Cotton Industry in Egypt. *Br. J. Ind. Med.* 19:126-130 (1962).
2. Awad El Karim, M.A., Osman, Y., El Haimi, Y.A.: Byssinosis: Environmental and Respiratory Symptoms Among Textile Workers in Sudan. *Int. Arch. Occup. Environ. Health.* 57:101-108 (1986).
3. Mustafa, K.Y.: Byssinosis in Tanzanian Textile Workers. *Lung* 159:39-44 (1969).
4. Morgan, P.G.M., Ong, S.G.: First Report of Byssinosis in Hong Kong. *Br. J. Ind. Med.* 38:290-292 (1981).
5. Schilling, R.S.F.: Byssinosis in Cotton & other Textile workers. *Lancet.* 2:261-265 (1956).
6. Molyneux, M.K.B., Tombleson, J.B.L.: An Epidemiological Study of Respiratory Symptoms in Lancashire Mills, 1963-1966. *Br. J. Ind. Med.* 27:225-234 (1970).
7. Berry, G., Molyneux, M.K.B., Tombleson, J.B.L.: Relationship between Dust Level & Byssinosis & Bronchitis in Lancashire Cotton Mills. *Br. J. Ind. Med.* 31:18-27 (1974).
8. Schilling, R.S.F.: Epidemiological Studies of Chronic Respiratory Diseases Among Cotton Operatives. *J. Biol. Med.* 37:55-74 (1964).
9. Berry, G., McKerron, C.B., Rossiter, C.E., Tombleson, J.B.L.: A study of Acute and Chronic Changes in Ventilatory Capacity in Workers in Lancashire Cotton Mills. *Br. J. Ind. Med.* 30:25-36 (1973).
10. Bouhuys, A., Schoenberg, J.B., Beck, G.J., Schilling, R.S.F.: Epidemiology of Chronic Lung Disease in a Cotton Mill Community. *Lung.* 154:167-186 (1977).
11. Mair, A., Smith, D.A., Wilson, W.A., Lockhart, W.: Dust Diseases in the Dundee Textile Workers. *Br. J. Ind. Med.* 17:272-278 (1960).
12. Wolde, Yohannes M.: *Health Profile & Plan of Action for Bahir Dar Awraja.* Ministry of Health, Educational Health Service Report. Addis Ababa (1987).
13. Schilling, R.S.F., Vigliani, E.C., Lammers, B., Valic, F., Gilson, J.C.: A Report on a Conference on Byssinosis. (14th International Conference on Occupational Health, Madrid, 1963). *Excerpta. Media.* 2:137-145 (1964).
14. Fletcher, C.M.: Chronic Bronchitis. *Am. Rev. Respir. Dis.* 80:483-484 (1959).
15. Hinshaw, H.D., Garland, L.H.: "*Diseases of the Chest.* 2nd Ed. pp 299. W.B. Saunders Co., Philadelphia (1963).
16. Isselbacher, K.J., Adams, R.D., Braunwald, E., Petersdorf, R.G., Welson, J.D.: *Harrison's Principles of Internal Medicine.* 11th Ed. pp 1412-1414. McGraw-Hill Inc. Hamburg (1987).
17. Cherniack, R.M., Rater, M.B.: Normal Standards for Ventilation Function Using an Automated Wedge Spirometer. *Am. Rev. Respir. Dis.* 106:38-46 (1972).
18. Bouhuys, A., Gilson, J.C., Schilling, R.S.F.: Byssinosis in the Textile Industry. *Arch. Environ. Health.* 21:475-478 (1970).
19. *American Conference of Government Industrial Hygienists.* Threshold Limit Values, AGGIH, Cincinnati, Ohio (1983).
20. Awad El Karim, M.A., El Hag, A.A.: Byssinosis and Tuberculosis in Cotton Industry in Sudan. *East. Afr. Med. J.* 62:491-500 (1985).
21. Noweir, M.H., Noweir, K.H., Ossman, H.A., Moseillin, M.: An Environmental & Medical Study of Byssinosis and other Respiratory conditions in the Cotton Textile Industry in Egypt. *Am. J. Ind. Med.* 6:173-183 (1984).
22. Holness, D.L., Taraschuk, L.G., Pelmeur, P.L.: Effect of Dust Exposure in Ontario Cotton Textile Mills. *J. Occup-Med.* 25:26-69 (1983).
23. Ong, S.G., Jam, T.H., Wong, C.M., Ma, P.L., Lam, S.K., O'Kelly, E.J.: Byssinosis in Hong Kong. *Br. J. Ind. Med.* 42:499-52 (1985).
24. Parikh, J.R., Chatterjee, B.B., Rao, N.M., Bahgia, L.I.: *The Clinical Manifestations of Byssinosis in Indian Textile Workers.* NIOH (National Institute of Occupational Health.) pp. 24-28. Ahmedabad, India.
25. Fox, A.J., Tombleson, J.B.L., Watt, A., Wilkie, A.G.: A Survey of Respiratory Disease in Cotton Operatives. Part II Symptoms, Dust Estimations & the Effect of Smoking Habit. *Br. J. Ind. Med.* 30:48-53 (1973).
26. Merchant, J.A., Lumsden, J.C., Kilburn, K.H., O'Fallon, W.M., Ujda, J.R., Germino, V.H., Hamilton, J.D.: An Industrial Study of the Biological Effects of Cotton Dust & Cigarette Smoke Exposure. *J. Occup. Med.* 15:212-221 (1973).
27. Bouhuys, A.: Asthma & Byssinosis. *Rev. Allergy.* 22:473-476 (1966).
28. Jones, R.N., Butcher, B.T., Hammand, Y.Y., Diem, J.E., Glindmeyer, H.W. III, Jehler, S.B., Hughes, J.M., Weill, H.: Interaction of Atopy & Exposure to Cotton Dust in the Bronchoconstrictor Response. *Br. J. Ind. Med.* 37:141-146 (1980).
29. McKerron, C.B., McDermoth, M., Gelson, J.C., Schilling, R.S.F.: Respiratory Function During the Day in Cotton Workers: A Study in Byssinosis. *Br. J. Ind. Med.* 15:75-83 (1958).
30. Buck, M., Bouhuys, A.: A Purified Extract from Cotton Bracts Induces Airway Constriction in Humans. *Chest.* 79:43-49 (1981).
31. Beck, G.J., Schachter, E.N.: The Evidence for Chronic Lung Disease in Cotton Textile Workers. *Am. Stat.* 37:404-412 (1983).
32. Schachter, E.N., Maunder, L.R., Beck, G.J.: The Pattern of Lung Function Abnormalities in Cotton Textile Workers. *Am. Rev. Respir. Dis.* 124:523-527 (1984).
33. Beck, G.J., Schachter, E.N., Maunder, L., Schilling, R.S.F.: A Prospective Study of Chronic Lung Disease in Cotton Textile Workers. *Am. Int. Med.* 97:645-651 (1982).

ACKNOWLEDGEMENTS: We acknowledge with many thanks the cooperation of Drs. Getachew Tadesse, Zein Ahmed Zein, Gebreselassie Okubagzi, Yemane Asgedom and all of the colleagues who have contributed much to the successful completion of this study. We are greatly indebted to the International Development and Research Centre (IDRC) for generously funding this project. Thanks are also given to Drs. Charles Larson and Francis Larson for their kind advice.

RESPIRATORY SYMPTOMS AND DUST EXPOSURE IN THE WOOL TEXTILE INDUSTRY

R.G. LOVE, Ph.D. • C.O. Jones, MSc • D. Gurr • C.A. Soutar, M.D. • A. Seaton, M.D.

Institute of Occupational Medicine, Edinburgh U.K.

Previous studies have indicated that respiratory symptoms are more prevalent in workers exposed to wool mill dust than in those who are not^{1,2,4,5,7,9} but only one study of respiratory symptoms in wool textile workers in the United Kingdom has been reported.¹

Moll⁶ first identified cases of occupational asthma among workers exposed to wool in 1933 but more recent studies have reported non-specific symptoms of chronic bronchitis and shortness of breath as the main respiratory condition experienced by between 5% and 50% of the workforce depending on age and length of exposure.^{2,4,5} Other studies of wool textile workers have also indicated a fall of lung function during a work shift⁹ or on the first day back at work.⁷ Bacterial endotoxin has been implicated as the aetiological agent in the most recent study.⁷

We have undertaken an epidemiological survey of over two thousand workers in the woollen, worsted and carpet yarn sectors of the industry and have compared the frequencies of respiratory symptoms reported by these workers with measured concentrations of inspirable wool mill dust in their immediate vicinity by means of personal dust sampling.

METHODS

Fifteen wool textile mills employing 2783 workers in and around Bradford, Dewsbury and Huddersfield in West Yorkshire were selected to participate in the study. They represented all the main processes which are carried out in the industry, and ranged in size from 4 to nearly 400 employees. We designed a respiratory symptoms questionnaire intended to establish a broad range of symptoms and their possible temporal and locational relationships to occupation and current dust exposure. Questions about cough, phlegm, wheezing, chest tightness, breathlessness and its variability, rhinitis, conjunctivitis, nosebleeds, chills and chest illnesses were included, some of these qualified by additional questions identifying exacerbation or improvement of symptoms at different times of day, days of the week, seasons and in particular places. Detailed smoking histories and occupational histories including details of shifts and part-time work were also obtained from which jobs could be allocated to occupational groups. These questionnaires were translated into Urdu for use on Asian workers who did not speak fluent English.

Concentrations of inspirable dust were measured using Institute of Occupational Medicine personal inspirable dust samplers, which were worn for part or all of a shift by

representative workers in each job or process, a larger number of samples being collected in the dustier jobs. Average inspirable dust concentrations were assigned to each of 16 occupational groups, based on the measurements made at the mill concerned or estimates derived from log-linear models from the measurements made elsewhere. Endotoxin levels in dust were also measured in a limited number of static samples at six mills by the Limulus method.⁸ These measurements were performed under the direction of Dr. M.D. Topping, Occupational Medicine and Hygiene Laboratory, Health and Safety Executive).

Logistic regression analyses were used to assess the contribution of independent variables such as dust concentration to explain the variation in each of the symptoms separately.

RESULTS

Inspirable dust concentrations based on 630 personal samples ranged from zero in non-process work to over 100 mg/m³ in some very dusty processes, such as work with wool waste. Over 9% of the workforce were exposed to shift average dust levels greater than 10 mg/m³, the nuisance dust standard currently applied to the industry. Wool opening, blending, worsted carding and carpet yarn backwinding were particularly dusty jobs, average levels being as high as 14.8, 180.5, 39.1, and 46.7 mg/m³ respectively in some mills. Endotoxin was found in measurable quantities (up to 650 ng/mg dust) in several samples throughout the process.

Complete questionnaire data were available for 2151 workers, which represents 85% of the available workforce. Of these workers 77% were male, 69% European, 28% Asian and 3% West Indian in origin. Just under half were current smokers. Eighteen percent opted to be interviewed in Urdu.

Symptom prevalences in the population overall were as follows: Chronic bronchitis (persistent cough and phlegm), 9%; wheeze (at any time), 31%; breathlessness grade 3 (walking with others on level ground), 10%; persistent rhinitis, conjunctivitis and chills, 18%, 10% and 2% respectively and 10 or more nosebleeds in the past year, 2%. The first five of these symptoms were significantly related to current dust concentration once age, sex, smoking habit and ethnic group had been allowed for. Table I shows the prevalence of these symptoms at increasing inspirable dust levels.

The results of the logistic regression analysis predicted a rapid rise in symptom prevalences over the dust concentration range

0.5 mg/m³ and a slower increase at higher concentrations up to 20 mg/m³ and above (Table II). The highest relative risks in non-smokers for some of the more important symptoms were found among European women and were, in relation to non-dust exposed, non-smoking women aged 40, 2.47 for rhinitis, 2.77 for chronic bronchitis, 3.56 for conjunctivitis and 6.20 for grade 3 breathlessness at concentrations of 10 mg/m³.

In addition, the risk of taking time off work because of chest illnesses increased significantly with increasing dust exposure, and dyers and scourers had a four-fold higher risk despite low dust exposures.

DISCUSSION

This study was designed to include the full range of working conditions to be found in the British wool textile industry. The entire workforce of 15 mills was encouraged to participate and the overall response rate of 85% gives confidence that the results are reasonably representative of the whole current workforce. The specially designed questionnaire was intended to identify all the common respiratory symptoms, in order to assess the syndromes related to wool dust exposure. Inclusion of material from other tried and tested questionnaires; thorough testing for comprehensibility and ease of use; and the similar relations of symptoms and smoking habit among

Table I
Symptom Prevalences in Groups Exposed to Different Dust Levels

Symptom	Grade	Dust concentration (mg/m ³)				
		<0.1 (4)*	0.1-1 (1206)	1-10 (740)	10-100 (187)	>100 (6)
Cough and Phlegm	Occasional	25	19.6	25.2	37.4	50
	Persistent	0	5.8	10.8	19.8	33.3
Wheeze	Present	50	24.6	35.3	55.1	66.7
Breathlessness	2 and 3	25	39.3	40.8	60.4	50
	4 and 5	0	1.8	3.0	1.6	0
Rhinitis	Occasional	25	15.7	19.7	29.4	0
	Persistent	0	14.9	19.3	36.9	16.7
Conjunctivitis	Occasional	25	11.3	12.6	23.0	33.3
	Persistent	0	8.0	10.0	23.0	50

* Number of individuals in group

Table II
Estimated Frequencies* of Symptoms, Predicted for
Different Inspirable Dust Concentrations in Current Job

Estimated symptom frequency (%)	Dust concentration (mg/m ³)				
	0	2.5	5	10	20
Persistent cough and phlegm	5	9	11	12.5	14.5
Breathlessness, grade 3 or more	6	10.5	13	14	14.5
Persistent rhinitis	12	18	20	22	23
Persistent conjunctivitis	6	10	11.5	13.5	16.5

* weighted averages of estimated frequencies for non-smokers and current smokers aged 40, assuming a population including proportions of smokers, non-smokers, men, women, ages and ethnic groups similar to the population under study.

different ethnic groups and Urdu speakers also encourages us to have confidence in the results of this questionnaire. Furthermore the consistency of the results across all factories and other subgroups of the workforce, and consistency between symptom complexes, is strong evidence that the associations between symptoms and inspirable dust concentrations are real. We selected the inspirable fraction, which includes the respirable fraction, because of our concern with health effects on the nose as well as the lungs.

Our results confirm previous reports of respiratory symptoms related to exposure to dust or length of time spent working in wool textile mills.^{1,2,4,5,7,9} We also identified the presence of endotoxin in a limited series of measurements and further studies are currently being undertaken to investigate the possible role of endotoxin in the causation of respiratory disease among wool textile workers. Indeed a recent study has implicated bacterial endotoxin in the aetiology of a byssinotic-like condition among Turkish carpet weavers.⁷

The questionnaire responses indicate dust related disease at all levels of the respiratory tract, although it is not clear whether the pathogenesis of this response includes pharmacological, toxic or allergic mechanisms, or is merely a response to the physical dust load.

Evidence (not presented here) from exploratory questions on the variability of breathlessness suggests that, although related to dust exposure, such symptoms are relatively infrequent, about 3% overall. Therefore these symptoms are in most cases not very like asthma but require further investigation as does the observation of increased risk of time off work because of chest illnesses amongst workers involved in the scouring (hot, usually alkaline, washing) and dyeing of wool. The latter process has been shown to be associated with increased respiratory and nasal symptoms of either an irritant or a specific allergic nature.³ Positive responses to questions about chills (shivering or feverishness), an attempt to identify symptoms of humidifier fever, were unduly frequent in some occupational groups but did not, as expected, show any relation with exposure to dust.

The functional and prognostic implications of wool dust related symptoms are not yet known. However, recent studies undertaken by us suggest that dust related functional impairment does occur, slight but significant reductions of FEV₁ and FVC being observed among Asian men and reduced FEV₁/FVC ratio among European women. An additional loss

of FEV₁ among dyers and scourers (unrelated to dust exposure) is consistent with the observations on respiratory illnesses made by ourselves and others.³ Other investigations currently being pursued suggest that inflammatory and non-specific immunological responses can be caused in rodent models by inspirable wool mill dust and we intend to report on these shortly.

Meanwhile, we can conclude that exposure to wool mill dust appears to be related to symptoms, when exposure is within "nuisance dust" limits of 10 mg/m³. At this concentration the overall estimated risks of symptoms relative to unexposed workers are: chronic bronchitis, 1.37; wheeze, 1.40; breathlessness grade 3 or more, 1.48; persistent rhinitis, 1.24; and persistent conjunctivitis, 1.70. The relative risk of these symptoms increases rapidly up to 5mg/m³ and more slowly thereafter. The results of these studies and further investigations into the functional and other characteristics of respiratory conditions among wool textile workers, should be helpful in making decisions on an airborne dust standard for the wool textile industry.

REFERENCES

1. Allardice, J.T., Clarke, E.C., Jones, R.D.: A study of the prevalence of epistaxis and respiratory symptoms in carpet backwinders. *J. Soc. Occup. Med.* 33:36-41 (1983).
2. Brysiewicz, K., Buluk, H., Cesar-Fronczyk, M., Korkecha, J., Leszczynski, B., Lukjan, K., Sadokierska, H.: The effect of work in dusty surroundings on the prevalence of chronic bronchitis among the workmen of Sierzon's establishments of the wool industry at Bialystok. *Gruzlica* 38:657-661 (1970).
3. Docker, A., Wattie, J.M., Topping, M.D., Luczynka, C.M., Newman-Taylor, A.J., Pickering, C.A.C., Thomas, P., Gompertz D.: Clinical and immunological investigations of respiratory disease in workers using reactive dyes. *Br. J. Ind. Med.* 44:534-541 (1987).
4. Jordeczka, S., Basa, S., Basa B.: Prevalence of chronic non-specific bronchopulmonary disease in wool industry workmen. *Gruzlica* 38:643-650 (1970).
5. Mathur, K.C., Misra, S.N.: Incidence of pulmonary disease among wool workers. *Indian J. Chest Dis.* 14:172-178 (1972).
6. Moll, H.H.: Occupational asthma with reference to wool sensitivity. *Lancet* 1:1340-1342 (1933).
7. Ozesmi, M., Aslan, H., Hillerdal, G., Rylander, R., Ozesmi, C. Baris, Y.I.: Byssinosis in carpet weavers exposed to wool contaminated with endotoxin. *Br. J. Ind. Med.* 44:479-483 (1987).
8. Rylander, R., Haglind, P., Lundholm, M.: Endotoxin in cotton dust and respiratory function decrement among cotton workers in an experimental cardroom. *Am. Rev. Resp. Dis.* 131:209-213 (1985).
9. Zuskin, J.H., Valic, F., Bouhuys, A.: Effect of wool dust on respiratory function. *Am. Rev. Resp. Dis.* 114:705-709 (1976).

Supported by a grant from the Health and Safety Executive.

ALUMINUM INHALATION REDUCES SILICOSIS IN A SHEEP MODEL

R. BÉGIN, M.D. • F. Dubois, M.D. • A. Cantin, M.D. • S. Massé, M.D. •
A. Dufresne, Ph.D. • G. Perrault, Ph.D. • P. Sébastien, Ph.D.

Université de Sherbrooke, Sherbrooke (QC), Institut de Recherche en Santé et Sécurité au Travail,
Montréal (QC) and Dust Disease Research Unit, McGill University, Montréal (QC)

INTRODUCTION

Although effective methods of prevention of silicosis have been known for years and implemented in the workplace through legislation, the disease remains of public health interest with some 200 new cases per year from an estimated workforce of 150,000 exposed workers in Canada.⁸

The recent availability of a soluble and inert compound, aluminum lactate (Al) has contributed to the renewed interest of aluminum therapy in silicosis. We have recently documented that Al suppresses the biological activity of quartz up to 10 months after exposure with faster clearance of the Al coated quartz particles.⁴ In this study, we evaluate the efficacy of soluble Al aerosol inhalation to alter the biological activity and disease process associated with silica exposure in the sheep tracheal lobe model.

MATERIALS AND METHODS

Experimental Design

The flock of 40 sheep was randomly divided in 4 groups of 10 sheep. The first group was exposed to 100 ml phosphate buffered saline (PBS) infusion in the tracheal lobe followed by monthly inhalation of 10 ml PBS (group PBS-PBS). The second group was exposed to 100 ml PBS followed by monthly inhalation of 100 mg Al in 10 ml PBS (group PBS-Al). The third group was exposed to 100 mg Minusil-5[®] (Pennsylvania Glass Y Sand Co., Pittsburg, PA) in 100 ml PBS followed by monthly inhalation of 10 ml PBS (groups Si-PBS). The fourth group was exposed to 100 mg Minusil-5[®] in 100 ml PBS followed by monthly inhalation of 100 mg Al in 10 ml PBS (group Si-Al).

Minusil-5[®] particles have been well characterized,³ 99.9% of diameter <5 μm and 95% <1 μm .

Exposures were carried out via bronchoscopic catheterization of the tracheal lobe bronchus and slow infusion of the suspension in the lobe. Inhalations were carried out 24 hr after bronchoalveolar lavage (BAL) with the animal intubated and breathing a mist of nebulized 0.01 to 4 μ -sized liquid particles with a Bird Mark 8 pressure ventilator (Bird Corp. Richmond, Ca) set at a maximal pressure of 25 cm H₂O for 20 minutes. Exhaled gases were vented outside the room. BAL were carried out after wedging the distal tip of the bronchoscope in the tracheal lobe bronchus by slow infusion of four 50 ml 39°C aliquots of PBS through a 50-ml syringe attached to the work

channel of the bronchoscope and by gentle aspiration of the effluent. BAL were performed prior to exposures and at monthly intervals after. Animals were sacrificed and autopsied at month 6.

Bronchoalveolar Lavage

The BAL cell differential populations were determined on cytocentrifuge smears stained with Wright-Giemsa. In the supernatant, albumin, IgG and IgM were determined by the immunochemical method (Cappel Lab. Inc., Downington, PA). The activity of lactate dehydrogenase (LDH) was measured by spectrophotometric method. BAL phospholipids were measured by the technique of Bartlett^{1,2} and contribution of lecithin and phosphatidylglycerol determined on the basis of their PO₄ content.

To assess interstitial lung matrix changes we looked at the glycoaminoglycan and fibronectin accumulation in BAL fluid. Oxidant production by alveolar macrophages was evaluated according to methods previously developed.⁶

Histopathology

The tracheal lobe was identified and 9 samples of the lobe of each sheep were obtained and each evaluated histologically for intensity and profusion of lesions to yield our average pathologic index of disease.

Determination of Quartz Concentration in Lung Tissue and Lavage

For each sheep in the study, a large fragment of the tracheal lobe was analyzed for quartz concentration using X-ray diffractometry.⁷

RESULTS

Lung Lavage Cellularity

The total and differential cell counts per lavage were similar in the group PBS-PBS and the group PBS-Al throughout the study. All silica-exposed sheep demonstrated at month 1 a 3 to 10-fold increase in cellularity which was sustained in the group Si-PBS but significantly attenuated to control levels in the group Si-Al ($p < 0.01$). In the Si exposed sheep, macrophages, lymphocytes and neutrophils were increased but there was no significant change in the eosinophil counts which were less than 4% at all times.

Lung Lavage Biochemistry

Albumin averaged $70 \pm 8 \mu\text{g/ml}$ in the group PBS-PBS and did not vary significantly over time. In the group PBS-AI, albumin levels were comparable ($p > 0.05$). In the Si-PBS group, there was a transient increase to 200% control level at month 1 with gradual return to control levels by month 5. In the Si-AI group, albumin remained at control level after AI inhalation. Lactate dehydrogenase levels in the PBS-PBS group averaged $6 \pm 1 \text{ ml U/ml}$ and did not vary significantly; in the PBS-AI group, levels were comparable ($p > 0.05$). In the Si-PBS group, there was a significant sustained 6 to 8-fold increase but in the group Si-AI, after initial increase, the levels of lactate dehydrogenase returned to the PBS-PBS group levels. Surfactant showed patterns of response similar to that of lactate dehydrogenase in the 4 groups.

Fibronectin in Macrophage Supernatant

The production of fibronectin by alveolar macrophages in culture at month 6 was undetectable in groups PBS-PBS, PBS-AI and Si-AI but significantly increased at $2.1 \pm 1 \text{ ng}/10^6$ cells per 24 hours in the Si-PBS group ($p < 0.01$).

Oxidant Production and Glutathione

Lung cells of the PBS-PBS group at time 0 spontaneously released low amounts of superoxide ($1.77 \pm 0.55 \text{ nmol cytochrome-C reduced}/10^6 \text{ cells-hr}$) and hydrogen peroxide ($0.67 \pm 0.34 \mu\text{M}/10^6 \text{ cells-hr}$), and the release of oxidants did not change during the study period in any of the groups. Glutathione in the bronchoalveolar lavage fluid of the PBS-PBS group at time 0 was $0.23 \pm 0.05 \mu\text{M}$ and did not differ between groups throughout the study period.

Lung Silica Content

The concentration of quartz in the lung parenchyma of the tracheal lobe of the sheep 6 months after initial exposure was as follows: in the group PBS-PBS and in the group PBS-AI, it was undetectable. In the group Si-PBS, it was $2.83 \pm 0.98 \mu\text{g/mg}$ and in the group Si-AI it was 1.01 ± 0.74 ($p < 0.05$).

Pathological Scores of Disease

The lung morphology of the sheep in the group PBS-PBS and PBS-AI remained normal. In the group Si-PBS, we found

early nodular silicotic lesions composed largely of macrophages and lymphocytes with no evidence of collagen deposition comparable to those reported earlier,³⁻⁵ with a pathological score of disease of 2.9 ± 1.0 . In marked contrast, the group Si-AI had milder histological changes and a significantly lower score of 1.0 ± 0.3 ($p < 0.05$). In the Si-AI group, there was significant reduction of both the profusion and the severity scores ($p < 0.05$). Whereas well-defined silicotic nodules were seen in 8/10 sheep in the Si-PBS group, they were seen in only 1/10 of Si-AI sheep.

DISCUSSION

This study documents that soluble aluminum lactate aerosol inhalation does not alter the normal biological processes in the bronchoalveolar milieu and does not produce significant pathological lung damage. In this study, we have observed that AI inhalation at monthly intervals significantly suppresses the alveolitis of silicosis, reduces the intensity and profusion of the disease process, and accelerates the clearance of quartz particles from the lung tissue.

REFERENCES

1. Anner, B., Moosmayer, M.: Rapid determination of inorganic phosphate in biological systems by a highly sensitive photometric method. *Anal. Biochem.* 65:305-309 (1975).
2. Bartlett, G.R.: Phosphorus assay in column chromatography. *J. Biol. Chem.* 234:466-468 (1959).
3. B egin, R., Masse, S., Rola-Pleszczynski, M., Martel, M., Desmarais, Y., Geoffroy, M., LeBouffant, L., Daniel, H., Martin, J.: Aluminum lactate treatment alters and the lung biological activity of quartz. *Exp. Lung Res.* 10:385-399 (1986).
4. B egin, R., Masse, S., S ebastien, P., Martel, M., Boss e, J., Dubois, F., Geoffroy, M., Labb e, J.: Sustained efficacy of aluminum to reduce quartz toxicity in the lung. *Exp. Lung Res.* 13:205-222 (1987).
5. B egin, R., Mass e, S., S ebastien, P., Martel, M., Geoffroy, M., Labb e, J.: Late aluminum therapy reduces the cellular activities of simple silicosis in the sheep model. *J. Leukocyte Biol.* 41:400-406 (1987).
6. Hoidal, J.R., Fox, R.B., Lenarbe, P.A., Perri, R., Repine, J.E.: Altered oxidative metabolism responses in vitro of alveolar macrophages from asymptomatic smokers. *Am. Rev. Respir. Dis.* 123:85-89 (1981).
7. NIOSH Manual of Analytical Methods, 2nd Ed., vol. 5: Free Silica (Quartz, Cristobalite, Tridymite) in Airborne Dust. US Dept. of Health, Education and Welfare, Public Health Service, Centre for Disease Control, National Institute for Occupational Safety and Health, pp. 1-6. Cincinnati, Ohio (1977).
8. Task Force on Occupational Respiratory Disease, pp. 35-48. Health and Welfare Canada (1979).

PULMONARY TOXICITY OF ILLITE AND KAOLIN DUSTS

H. DANIEL • L. Le Bouffant • A. Wastiaux • P. Sébastien

CERCHAR, BP No. 2, 60550 Verneuil en Halatte, France

INTRODUCTION

Clay minerals kaolin and illite are present in some mixed dusts of industrial origin. Kaolin is an industrial mineral with many applications. It is used as a filler in the paper industry, as a filler and extending agent in rubber, paints, inks, plastics and insecticides, in the manufacture of China, refractory bricks, crucibles, saggars and glass, as a mild abrasive in soaps and toothpastes and as stiffener of textile. Dust possibly produced in these industries, but also smoking,² can be sources of exposure to fine kaolin particles. It is now accepted that the long term inhalation of high quantities of kaolin dust can lead to the development of a specific type of pneumoconiosis.¹¹ From the pathological viewpoint, the fibrosis is mainly nodular or massive,⁹ with important dust retention.¹⁴

Sources of exposure to illite and possible related-health effects are much less documented. The interest for illite came essentially from its presence in coal mine dust.³ It has been suggested that the in-vivo leaching of aluminum from illite particles could reduce the activity of the accompanying quartz particles.⁷ To our knowledge, the toxicity of illite particles has been tested in only few in-vitro or in-vivo experiments.^{1,5,8}

We have some evidence that both minerals can exhibit acute pulmonary toxicity after a single intratracheal injection.⁴ In a previous experiment, two groups of 50 female Wistar rats were injected with 50 mg of fine particles of either illite from Le Puy, or kaolin from Cornwall. Respectively 12% (illite group) and 45% (kaolin group) of the animals died of pulmonary oedema in the first week following the injection.

In this context, we found it useful to conduct long-term experiments to comparatively assess the fibrogenicity of illite and kaolin dust, alone or in combination with quartz.

METHODS

In a first series of experiments, illite (Le Puy), kaolin (Cornwall), quartz (Madagascar) and coal (Courrières low rank) were tested in the rat exposed by inhalation. Wistar female rats were exposed for 3 months (5 h/d, 5 d/w) to 300 mg/m³ of respirable dust. Aerosol generators and inhalation facilities are described in detail elsewhere.⁶

In a second series, animals received a single intratracheal injection of either quartz (12.5 mg), quartz + illite (12.5 mg + 37.5 mg) and quartz + kaolin (12.5 mg + 37.5 mg). Injected particles were prepared by cyclone separation and were of respirable size.

In both series, the pulmonary response was assessed at month 6, 12, 18 and 24. Animals (10 per subgroup) were killed and the lungs removed. The weight of fresh lung was recorded for each animal.

Left lobes were used for histopathological examination. They were perfused under 25 cm H₂O pressure and fixed in 10% neutral buffered formalin. Sections stained by hematoxylin eosine and Picrosirius were examined at three different locations under crossed polaroid filters. In each group, remaining fragments of lung tissue were pooled, dried and analyzed for collagen, lipids and dust. Collagen was measured by the method of Stegeman.¹² Coal in the lung was measured gravimetrically after extraction by the formamide technique.¹³ For quartz and clay, lung dust was extracted by low temperature ashing, ash suspension, and filtration through a polycarbonate membrane filter. Quantity of quartz on the membrane was determined by X-ray diffractometry. Quantity of clay was deduced from aluminum concentration measured by X-ray fluorescence.

RESULTS

Main results of the inhalation experiments are reported in Figure 1. Similar conditions of exposure yielded to different dust retentions in the lung. The highest retention was observed with coal and the lowest with quartz, clay retention being situated in between. For clays, there was no evidence of pulmonary clearance after month 12. At month 6, the mean weight of fresh lung was 5 times above control value in the quartz group; it was only slightly elevated in the other groups. In the following periods, the lung weight increased much more in the quartz group than in the other groups. A similar pattern was observed with pulmonary collagen.

Main results of the intratracheal injection experiments with the quartz and quartz/clay mixtures are reported in Figure 2. At month 6 and 24, respectively 48% and 37% of the injected dose was still present in the lungs of animals exposed to quartz alone. Clay admixture had no clear effect on the clearance of quartz. It seemed, however, that overall quartz retention was somewhat higher in the quartz/illite group and somewhat lower in the quartz/kaolin group. Mean weight of fresh lung was 4–5 times above control value in the quartz group and in the quartz/kaolin group. Interestingly enough, the lung weight was only slightly elevated in the quartz/illite group. In all groups, the lung weight increased in the period 6–24 months. Results of collagen measurement clearly discriminated the three groups. The admixture of illite or kaolin to the injected quartz, respectively reduced or greatly enhanced the production of pulmonary collagen.

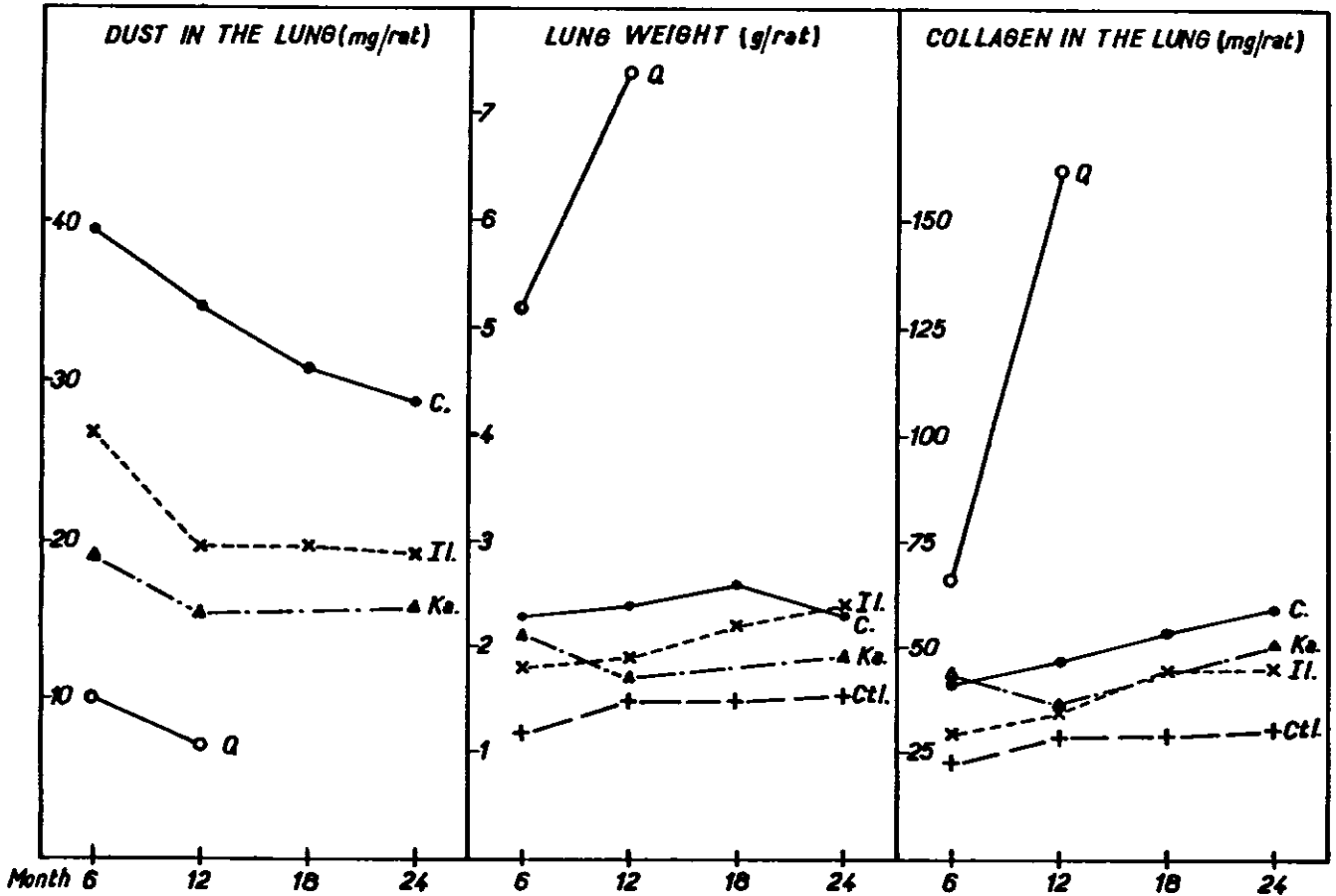

Figure 1. Wistar female rats exposed by inhalation (300 mg/m^3 , 3 months) to quartz (Q), kaolin (K), illite (I) and coal (C). Measurement of lung dust, weight of fresh lung and pulmonary collagen at month 6, 12, 18 and 24.

DISCUSSION

In our inhalation experiments kaolin and illite exhibited similar activities. During a two year period they produced very little collagenous fibrosis. These results agree with previous experimental observations.⁹ They are also similar to those obtained after inhalation of coal dust by experimental animals. It should not be concluded however, that kaolin, illite and coal dust have similar biological activities. First it must be remembered that results of these experimental tests are poor predictors of the pneumoconiotic risk in humans. Inhalation of coal mine dusts for example, can lead to disabling pneumoconiosis in miners, but these dusts exhibit very moderate activity in most of experimental tests. Secondly, there is some evidence from our experiments by intratracheal

injection that clay and coal dust behave differently in the lung.

An interesting observation was the pulmonary response to intratracheal injection of quartz/clay mixtures. Combination of quartz and kaolin gave rise to pronounced collagenous fibrosis, as already noticed.¹⁰ By contrast animals exposed to quartz/illite produced mixtures of less pulmonary collagen than animals exposed to the same dose of quartz alone. This clearly indicates that kaolin and illite behave differently in the lung. But apparently, this difference in behaviour had no detectable effect when the two clay minerals were tested individually. These findings illustrate once more how complex are the mechanisms of action of inhaled coal mine dust, which generally contains quartz, kaolin and illite.

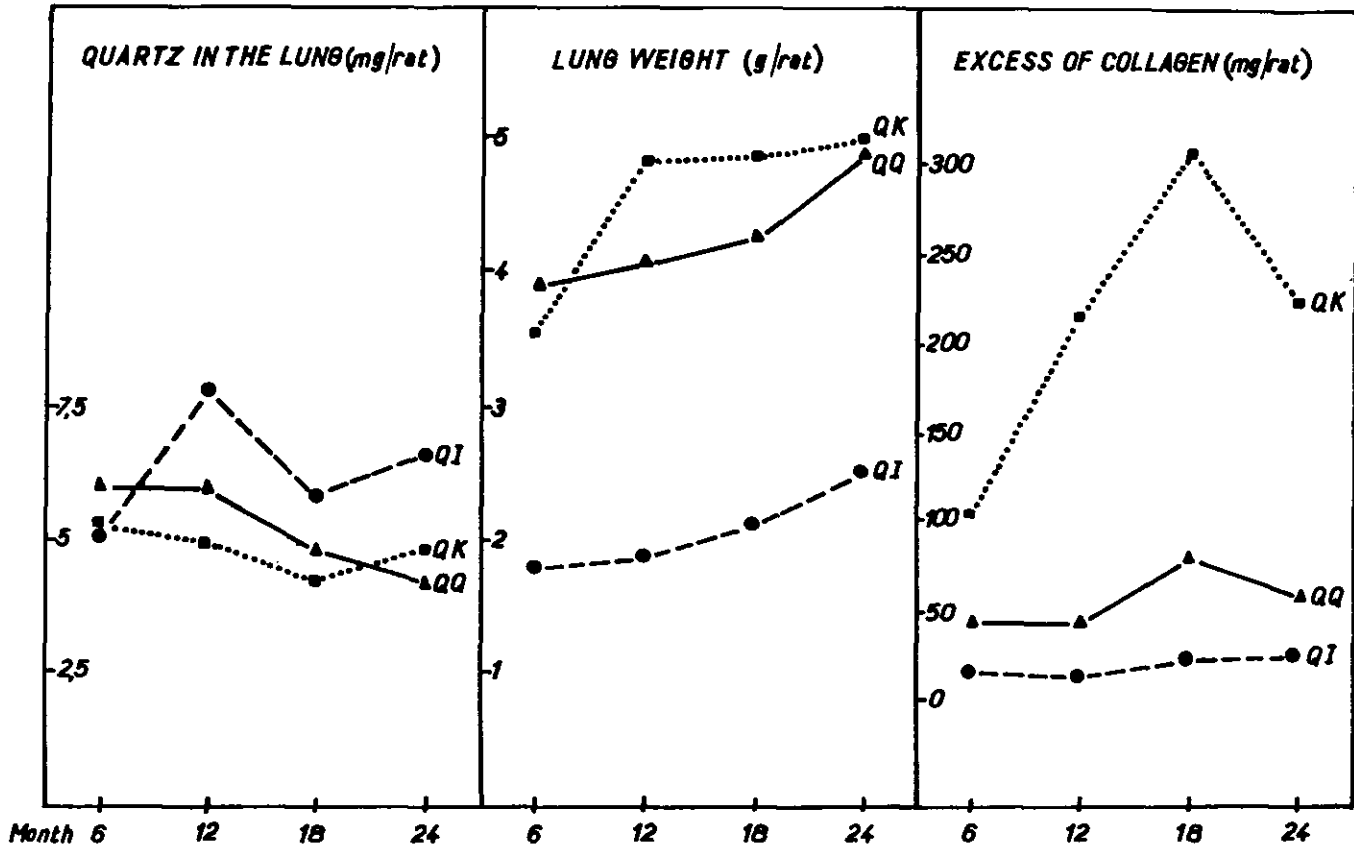

Figure 2. Pulmonary response to quartz/clay mixtures injected intratracheally in Wistar female rats. Measurement of lung quartz, weight of fresh lung and pulmonary collagen at month 6, 12, 18 and 24. Three dusts were injected: QQ 12.5 mg of quartz, QK 12.5 mg of quartz + 37.5 mg of kaolin, QI 12.5 mg of quartz + 37.5 mg of illite.

REFERENCES

1. Adamis, Z., Tatrai, E., Timar, M., Unguay, G.: *In-Vitro Effects of Mineral Dusts*, pp 453-458. Springer-Verlag, Berlin-Heidelberg (1985).
2. Brody, A.R., Craighead, J.E.: Cytoplasmic inclusions in pulmonary macrophages of cigarette smokers. *Lab. Invest.*, 32:125-132 (1975).
3. Bruch, J., Rosmanith, J.: *In-Vitro Effects of mineral dust*, pp 433-440. Springer-Verlag Berlin-Heidelberg (1985).
4. Daniel H. Personal communication (1987).
5. Gormley, I.P., Addison, J.: The in-vitro cytotoxicity of some standard clay mineral dusts of respirable size. *Clay Minerals*, 18:153-163 (1983).
6. Le Bouffant, L. *Inhaled Particles and Vapours*, pp 369-383, Pergamon Press, Oxford, London, New York, Paris, (1961).
7. Le Bouffant, L., Daniel, H., Martin, J.C., Bruyère, S.: Effect of impurities and associated minerals on quartz toxicity. *Ann. Occup. Hyg.*, 26-1-4:625-634 (1982).
8. Martin, J.C., Daniel, H., Le Bouffant, L.: *Inhaled Particles IV*, pp 361-370, Pergamon Press, Oxford (1977).
9. Parkes, W.R.: *Occupational Lung Disorders*, 2nd Ed. pp 310-313 Butterworths, London, Boston, Sydney, Wellington, Durban, Toronto (1982).
10. Schmidt, K.G., Luchtrath, H.: Die Wirkung von frischen und gebranntem kaolin auf die lunge und das Bauchfell von vatten. *Beitr. Silikoforsch.*, 58:1-37 (1958).
11. Spannhake, E.W., Menkes, H.A.: Kaolin and the lung. *Am. Rev. Respir. Dis.*, 127:141-142 (1983).
12. Stegeman, H.: Mikrobestimmung von hydroxyprolin mit chloramin-t und p-dimethylaminobenzaldehyd. *Hoppe-Sayler's Zeitschrift für Physiologische Chemie*, 311:41-45 (1958).
13. Thomas, N., Stegeman H.: Darstellung der fremsdstaube aus lungen ind ihre ergenschafter. *Beitrage Zur Silikose Forschung*. Herausgeber Bergbau-Forschungsinstitut, Bochum, 28-1-29 (1954).
14. Wagner, J.C., Pooley, F.D., Gibbs, A., Lyons, J., Sheers, G., Moncrieff, C.B.: Inhalation of China stone and China clay dusts: relationship between the mineralogy of dust retained in the lungs and pathological changes. *Thorax* 41:190-196 (1986).

TOXICOLOGICAL EVALUATION OF ASBESTOS SUBSTITUTE

O. RAHMAN, Ph.D. • S.G. Khan, M. Phil. • M. Aslam, M. Phil. •
P. K. Agarwal, M.D. • S. Ali, Ph.D.

Industrial Toxicology Research Centre, Post Box No. 80, Lucknow—226 001, India
Dept. of Pathology, K.G's Medical College, Lucknow—
226 003, India

INTRODUCTION

Epidemiological and experimental studies have proved that asbestos induces certain pathological changes in the lung like fibrosis known as asbestosis and two forms of malignancies, i.e. mesothelioma and bronchogenic carcinoma.^{30,35} In order to safeguard the workers from the hazardous effects of these fibres, scientists all over the world are trying to replace them with other natural and man-made mineral fibres. Among them, wollastonite is a promising asbestos substitute under trial in India. They are acicular or fibrous calcium silicates (CaSiO_3), and have attained additional significance due to their high thermal resistance properties. The use of wollastonite in ceramic tiles, etc., has given this mineral considerable attention as a substitute for asbestos fibres.^{1,25} A few reports are available on their biological effects. Skaug and Gylseth³⁸ have reported, on the basis of hemolytic studies of two natural and three synthetic calcium silicates, that synthetic silicates are more toxic than the natural. Bolton et al² have reported no major pulmonary damage in rats exposed to three different varieties of calcium silicate insulation materials. Moreover, a few cases of lung fibrosis, pleural thickening, chronic bronchitis and impairment of lung ventilatory capacity in wollastonite exposed workers have also been reported.^{11,20} However, no report is available on the biological activity of Indian varieties of wollastonite dusts. Therefore, in the present study, three varieties of Indian wollastonite, namely, kemolit A-60, kemolit-N and kemolit ASB-3 have been evaluated for their toxicity. Besides cytotoxic studies *in vitro* and fibrogenic responses *in vivo*, the effect of these fibres on the pulmonary xenobiotic metabolizing enzyme system was also evaluated, to monitor their influence in the presence of other carcinogens, if present in the system simultaneously either by smoking or from the other environmental sources. The results obtained from these studies were compared with chrysotile, the most toxic variety of asbestos and also a carcinogenic enhancer in the presence of tobacco smoke.³

MATERIALS AND METHODS

Dust

Wollastonite dust samples, kemolit A-60, kemolit-N and kemolit ASB-3 were obtained from Mr. Salil Singhal, Director, Wolkem Private Ltd. Udaipur (India). Particle size below 30 μ were prepared as described by Zaidi.⁴³ Chrysotile UICC standard reference sample particle size <30 μ was

obtained as a gift from Dr. J.B. Leinweber, Johns-Manville, U.S.A.

Chemicals

Benzo(a)pyrene, 3-hydroxy benzo(a)pyrene, styrene epoxide, 1-chloro, 2,4,-dinitrobenzene and bovine serum albumin were procured from Sigma Chemical Company, USA. All the other chemicals and reagents were either purchased from V.P. Chest Institute, New Delhi, India or Sisco Research Laboratory (SRL) Bombay, India, and were of analytical grade.

Hemolytic Studies

The lysis of 0.2% suspension of human erythrocyte in 0.01M Tris-HCl buffer pH 7.35 in 0.15M NaCl caused by 2 mg/ml each of different dusts was measured at 37°C after two hours except chrysotile where it was 10 minutes to avoid adsorption.³³

Treatment of Animals

Female albino rats from ITRC Colony, weighing 150-180 gm, were used. The dried dusts and 0.15 M NaCl were separately autoclaved at 15 lbs pressure for 15 min. The dusts were separately suspended in 0.15 M NaCl just before inoculation. The animals were divided into five groups. Intratracheal treatment of animals with dust were done according to the procedure as described by Zaidi.⁴³

Each animal of the experimental groups was instilled intratracheally with 5 mg of different dust samples separately, suspended in 0.5 ml of normal saline. Control groups received 0.5 ml of normal saline solution only. The animals were maintained on commercial pellet diet, supplied by Hindustan Lever Limited, Bombay, India, and tap water *ad libitum*. The animals were sacrificed at 90 days after the instillation of dusts. Lungs were taken out, weighed and a portion was fixed in 10% formal saline for histopathological studies, while the other portion was cut into small pieces and dried at 110°C for chemical estimation. Another set was taken for microsomal and cytosolic fractionations.

Histopathological Studies

Representative 5 μ paraffin sections were cut and stained with hematoxylin-eosin and VanGieson.

Isolation of Microsomes

The rat lung microsomal fraction was isolated by the modified procedure of Johannesen et al.²²

Enzyme Assays

Benzo(a)pyrene hydroxylase was assayed by the fluorimetric technique as described by Dehnen et al.⁸ The quantitation of phenolic metabolite was based on comparison of fluorescence to a standard solution of 3-hydroxy benzo(a)pyrene.

Epoxide hydratase activity was assayed by the fluorimetric technique, according to the method of Dansette et al.⁶ by using styrene epoxide as substrate.

Glutathione-S-transferase activity was determined by the procedure, described by Habig et al.,¹⁶ by using 1-chloro-2, 4-dinitrobenzene (CDNB) as substrate.

Chemical Estimation

Microsomal cytochrome P-450 was quantitated from carbon monoxide plus dithionite reduced difference spectra as described by Omura and Sato.³¹ An extinction coefficient of $91,000 \text{ cm}^{-1}\text{M}^{-1}$ was used for absorbance change between 450 and 490 nm.

Glutathione content was measured in rat lung cytosolic fraction according to the method of Ellmann.¹²

Ascorbic acid content was estimated in lung cytosol according to the procedure of Schaffert and Kingsley.³⁴

Enzymatic and non-enzymatic lipid peroxidation was determined by the procedure of Ottolenghi³² as modified by Hunter et al.¹⁹ estimating the malonaldehyde formed with 2-thiobarbituric acid.

Hexosamine and sialic acid were estimated in the fresh tissue by the methods of Dische and Broenfreund¹⁰ and Warren

respectively. Uronic acid and collagen were estimated by the method of Dische,⁹ and Stegmann et al.⁴¹ respectively in dry tissue. Phospholipids were extracted from dry tissue in chloroform: methanol (2:1) and were estimated by their phosphorous content by the method of Fiske and Subba Row.¹³

Protein content in trichloroacetic acid precipitate was estimated by the method of Lowry et al.²⁷ by using crystalline bovine serum albumin as standard.

RESULTS

In vitro Studies

Table I shows that all the wollastonite dust samples induced hemolysis and the order of hemolysis was 43.4%, 41.2% and 35.3% by kemolit A-60, kemolit-N and kemolit ASB-3 respectively. In comparison to chrysotile all the samples were less hemolytic.

In vivo Studies

Fibrogenic Response. The changes in the chemical composition and dry weight of the lung by different wollastonite samples are recorded in Table II. When compared with chrysotile,⁷ the increase in the collagen content and phospholipids by kemolit A-60 was significantly very high. There was no significant increase in the mucopolysaccharides by these dusts. Kemolit A-60 increased only the content of sialic acid.

The histopathological studies revealed mild to moderate amount of fibrosis of the lung alveoli (Figure 1). The animals exposed to Kemolit A-60 showed peribronchiolar areas of fibrosis (Figure 2) which was not found with any other dust. In some cases collection of chronic inflammatory cells and few abscesses were also seen on scanning the tissue (Figures 3 and 4).

Table I
Comparative Hemolysis of Chrysotile and Wollastonite Using Rat Erythrocytes

Dust sample	% Hemolysis
Chrysotile	72.16±3.29
Kemolit A-60	43.37±2.50
Kemolit - N	41.19±3.03
Kemolit ASB-3	35.28±1.65

The values represent mean of six separate experiments ± S.D.

Lung Weight

A significant increase in lung weight of all the experimental animals was observed, kemolit A-60 showed a higher increase in the lung weight as compared to kemolit-N and kemolit ASB-3 (Figure 5).

Effects of Different Dusts on Lung Microsomal and Cytosolic Fractions

Figure 6 shows the increase in the cytochrome-P-450 content by different dusts. Chrysotile showed the maximum increase followed by kemolit A-60. Activities of benzo(a)pyrene hydroxylase and epoxide hydratase is recorded in Figure 7 and 8. Among all the dust samples kemolit A-60 induced maximum increase but in comparison to chrysotile the increase was of lower magnitude. The alteration in the activity of glutathione-S-transferase is recorded in Figure 9. Chrysotile

decreased the activity of this enzyme significantly, while kemolit A-60 decreased the activity 9% which was three times less than observed by chrysotile. Kemolit-N and kemolit ASB-3 increased the activity of glutathione-S-transferase.

Effect on Water Soluble Antioxidants

Statistically, chrysotile and kemolit A-60 induced significant decrease in the content of ascorbic acid as reported in Figure 10, while glutathione content was significantly decreased only by chrysotile (Figure 11).

Effect on Microsomal Lipid Peroxidation

Chrysotile and kemolit A-60 induced significant lipid peroxidation both enzymatically and non-enzymatically, followed by kemolit-N. There was no change by kemolit ASB-3 (Table III).

Table II
Changes in the Lung Weight and Composition of Control and Wollastonite Treated Rats

Parameters	Control	Kemolit A-60	Kemolit N	Kemolit ASB-3
Dry Weight (mg/g fresh tissue)	204±23	237±21 ^d	218±19	205±19
Lung protein (mg/g fresh weight)	100±8.2	105±5.8 ^d	103±2.5	101.4±1.9
Hexosamine (mg/100 mg fresh tissue)	2.00±0.14	2.16±0.054	2.09±0.08	2.04±0.08
Sialic acid (mg/100 mg fresh tissue)	3.34±0.14	3.70±0.23	3.47±0.48	3.44±0.56
Uronic acid (mg/g dry weight)	23.38±3.98	28.10±4.84	26.65±3.57	25.96±2.71
Collagen (mg/g dry weight)	39.36±3.87	61.45±11.87 ^c	48.93±7.32	45.76±5.56
Phospholipids (mg/g dry weight)	7.96±0.46	13.31±0.33 ^a	9.31±0.09 ^b	8.57±0.13 ^d

The values are expressed as mean ± S.D. of six animals.

^a_p <0.001; ^b_p <0.01; ^c_p <0.02; ^d_p <0.05.

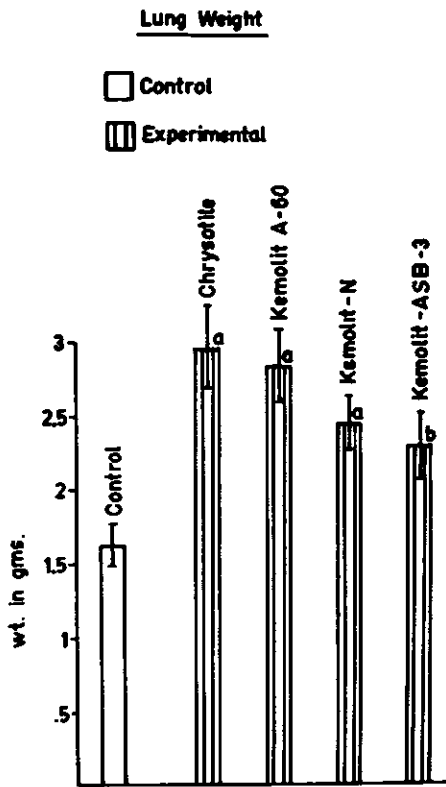

Figure 1. Section of rat lung tissue taken 90 days after the intratracheal inoculation of wollastonite showing interstitial fibrosis. 400x

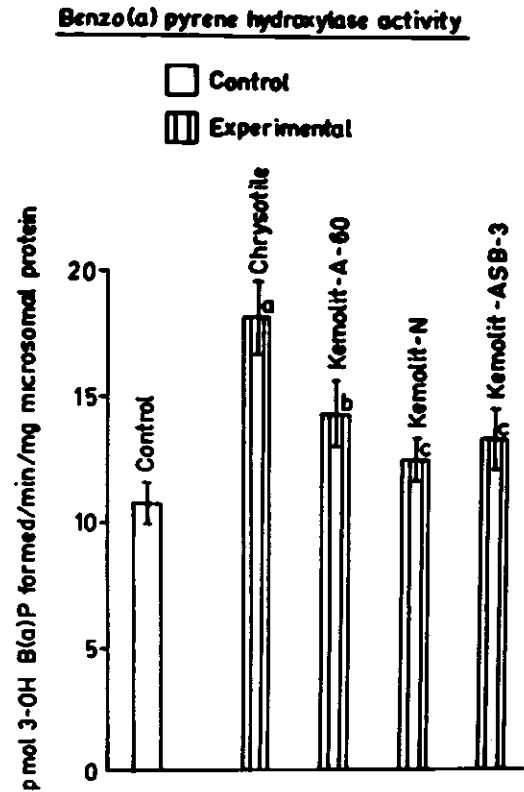

Figure 3. Section of rat lung tissue taken 90 days after the intratracheal inoculation of wollastonite showing inflammatory cells. 400x

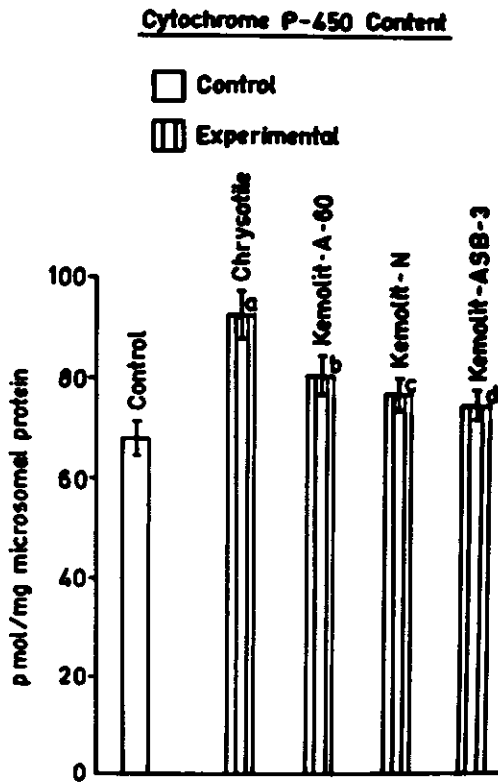

Figure 2. Section of rat lung tissue taken 90 days after the intratracheal inoculation of wollastonite showing peribronchiolar area of fibrosis. 400x

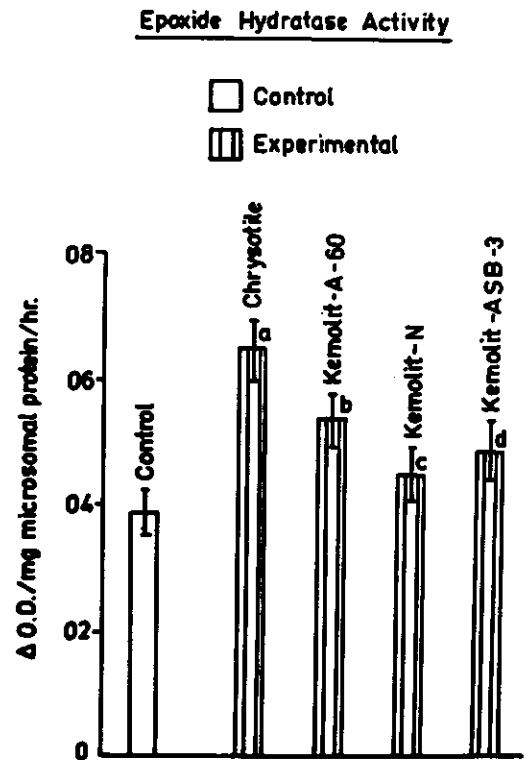

Figure 4. Section of rat lung tissue taken 90 days after the intratracheal inoculation of wollastonite showing abscess. 400x

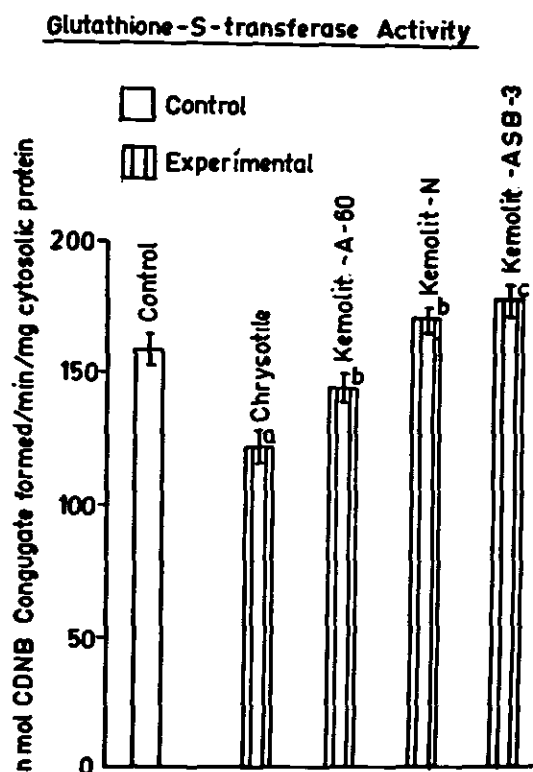

Figure 5. Fresh lung weight of control and dust treated animals. The values are expressed as mean \pm SEM of six animals ^ap < 0.001; ^bp < 0.02.

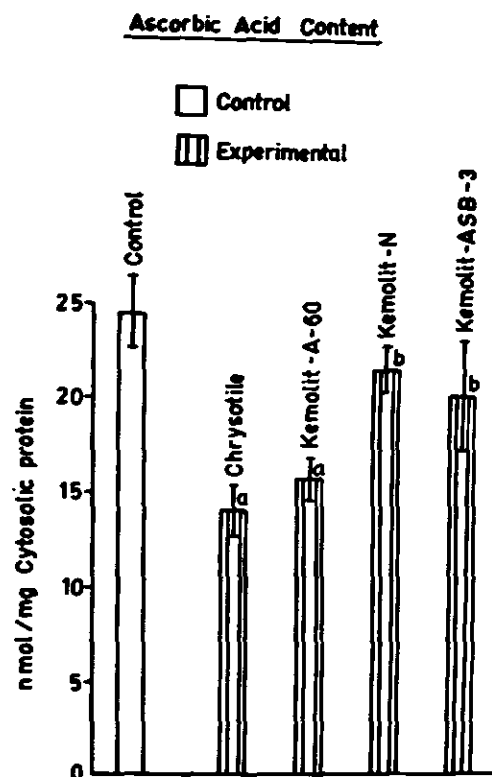

Figure 6. Lung cytochrome P-450 content of control and dust treated rats. Results represent mean \pm SEM of six animals, ^ap < 0.001, ^bp < 0.02, ^cp < 0.05, ^dp - N.S.

DISCUSSION

In the present study among the three varieties of wollastonite, kemolit A-60 was found most toxic. The cytotoxic index of these samples were much less than chrysotile¹⁸ using erythrocytes as *in vitro* model system³⁷ Kemolit A-60 was found to be the most fibrogenic dust. The fibrogenic pattern of these dusts tallied with those of Bolton et al.²

It appeared from the results that only kemolit A-60 could influence the activity of benzo(a)pyrene hydroxylase and epoxide hydratase in the diseased animals where fibrosis had already developed and collagen content was very high. However, when compared with chrysotile exposed animals where fibrosis had just begun and collagen content was lower than kemolit A-60 exposed animals, the activities of these enzymes were much less. Benzo(a) pyrene hydroxylase and epoxide hydratase play a crucial role in the formation of ultimate carcinogen derived from polynuclear aromatic hydrocarbons.^{14,24} Further activation of these enzymes induced by chrysotile may aggravate the situation in the presence of other carcinogens, if present in the system. The effect of these dusts on glutathione-S-transferase activity was very interesting. This enzyme catalysed the conjugation of the ultimate carcinogens with glutathione in the lungs, which are eventually eliminated.⁵ The inhibition of these enzymes and

the reduction of glutathione by chrysotile decelerate the above reaction, hence providing the accumulated metabolites with the opportunity of interacting with DNA.⁴² Similar results were also reported by Brown et al.³ On the other hand kemolit ASB-3 increased the activity of glutathione-S-transferase significantly which could facilitate the elimination of reactive metabolites of the PAHs from the system. The other two dusts, i.e., kemolit A-60 and kemolit-N did not have any significant effect on the activity of this enzyme. Chrysotile inhibited the content of water soluble antioxidants, like glutathione and ascorbic acid significantly. It is important to note this, since antioxidants are known to inhibit tumors induced by PAHs.^{23,36,39,40} Among the asbestos substitutes, kemolit A-60 decreased the content of ascorbic acid only and had no significant effect on glutathione but when compared with chrysotile the magnitude of decrease was much less. The decrease in ascorbic acid content by kemolit A-60 could be associated with its high fibrogenic response at this stage. Ascorbic acid is one of the important components of mammalian lungs defense against environmental pollutants.^{26,28} It is closely associated with environmental stress in man and animals.⁴ Therefore, its low level in lungs may hamper the defence of tissue against environmental pollutants. A higher rate of enzymatic and nonenzymatic lipid peroxidation was observed by chrysotile and kemolit A-60 while the induction

of LPO with kemolit-N was of lower magnitude and that with kemolit ASB-3 was insignificant. It is well documented that the induction of free radicals may be responsible for the pathogenicity produced by asbestos.^{15,17,21,29}

From these studies it is evident that in comparison to chrysotile asbestos, wollastonites were less cytotoxic and did not bring significant alterations in the drug metabolizing enzyme system. Concluding this paper we would like to emphasize that kemolit-N lies at one end of the spectrum being closely followed by kemolit ASB-3 with kemolit A-60 as the most toxic form of wollastonite.

REFERENCES

1. *Biological effects of mineral fibres*: pp 881-900, J.C. Wagner and W. Davis eds. IARC, Lyon, (1980).
2. Bolton, R.E., Addison, J., Davis, J.M.G., Donaldson, K., Jones, A.D., Miller, B.G., Wright, A.: Effects of inhalation of dusts from calcium silicate insulation materials in laboratory rats, *Environ. Res.* 39:26-43, (1986).
3. Brown, R.C., Fleming, G.T.A., Knight, A.J.C.: Asbestos effects on the *in vitro* uptake and detoxification of aromatic compounds. *Environ. Hlth. Prospect.* 51:315-318, (1983).
4. Calabrese, E.J.: Does exposure to environmental pollutants increase the need for vitamin C? *J. Environ. Toxicol. Oncol.* 5:81-90 (1985).
5. Cooper, C.S., Hewer, A., Ribiero, O., Growner, P.L., Sims, P.: The enzyme catalyzed conversion of antibenzo(a)pyrene 7,8-diol, 9,10 oxide into a glutathione conjugate. *Carcinogenesis.* 1:1075-1080 (1980).
6. Dansette, P.M., Dubois, G.C., Jerina, D.M.: Continuous fluorometric assay of epoxide hydratase activity. *Anal. Biochem.* 97:340-345 (1979).
7. Das, B., Misra, V., Rahman, Q., Viswanathan, P.N.: Lung mitochondria in experimental asbestosis. *Environ. Res.* 31:390-398 (1983).
8. Dehnen, W., Trmings, R., Roos, J.: A modified method for the assay of benzo(a)pyrene hydroxylase. *Anal. Biochem.* 53:373-380 (1973).

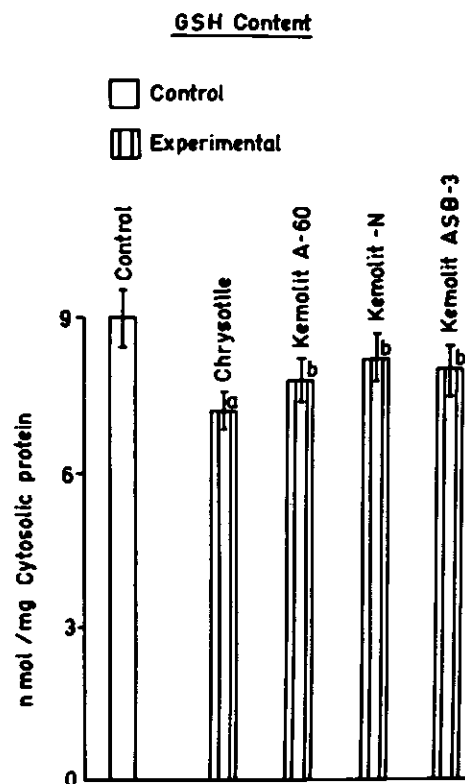

Figure 7. Benzo(a)pyrene hydroxylase activity in lung microsomes, isolated from control and dust treated rats. The values represent mean \pm SEM of six animals ^a $p < 0.001$, ^b $p < 0.02$, ^c $p - N.S.$

Table III
Lipid Peroxidation in Control and Dust Treated Animals

Treatments	Control	Chrysotile	Kemolit A-60	Kemolit N	Kemolit ASB-3
Microsomes	0.28 \pm 0.022	0.374 \pm 0.018 ^a	0.361 \pm 0.024 ^a	0.346 \pm 0.032 ^b	0.295 \pm 0.038 ^d
Microsomes + NADPH	1.28 \pm 0.12	2.154 \pm 0.16 ^a	2.054 \pm 0.13 ^a	1.73 \pm 0.18 ^c	1.55 \pm 0.14 ^d
Microsomes + Fe ⁺⁺	4.68 \pm 0.23	7.041 \pm 0.52 ^a	6.753 \pm 0.45 ^a	5.85 \pm 0.38 ^b	5.12 \pm 0.43 ^d

The values are expressed as mean \pm SEM of six animals.

^a $p < 0.001$; ^b $p < 0.02$; ^c $p < 0.05$; ^d $p - N.S.$

9. Dische, Z.: A modification of the carbazole reaction of hexuronic acids for the study of polyuronides. *J. Biol. Chem.* 183:489-492 (1950).
10. Dische, Z., Borenfreund, E.: A spectrophotometric method for micro determination of hexosamine. *J. Biol. Chem.* 184:517-522 (1950).
11. *Dust and Disease*: pp 251-256, R. Lemen and J.M. Dement, eds. Pathotox, Park Forest South (1979).
12. Ellman, G.L.: Tissue sulfhydryl groups. *Arch. Biochem. Biophys.* 82:70-77, (1959).
13. Fiske, C.H., Subba Row, Y.: Colorimetric determination of phosphorous. *J. Biol. Chem.* 66:375-400 (1925).
14. Gelboin, H.V.: Benzo(a)pyrene metabolism activation and carcinogenesis: role and regulation of mixed-function oxidases and related enzymes. *Physiol. Rev.* 60:1107-1166 (1980).
15. Graceffa, P., Weitzman, S.A.: Asbestos catalyzes the formation of the 6-oxobenzo(a)pyrene radicals from 6-hydroxybenzo(a)pyrene. *Arch. Biochem. Biophys.* 257:481-484 (1987).
16. Habig, W.H., Pabst, M.J., Jakaby, W.B.: Glutathione-S-transferase: The first enzymatic step in the mercapturic acid formation. *J. Biol. Chem.* 249:7130-7139 (1974).
17. Hansen, K., Mossman, B.T.: Generation of superoxide (O₂) from alveolar macrophages exposed to asbestiform and nonfibrous particles. *Cancer Res.* 47:1681-1685 (1987).
18. Hunt, J., Pooley, F.D., Richards, R.J.: Biological reactivity of calcium silicate composites—*in vitro* studies. *Environ. Res.* 26:51-68 (1981).
19. Hunter, F.E., Gabicki, J.M., Hoffstein, P.E., Einstein, J., Scott, A.: Swelling and lysis of rat liver mitochondria induced by ferrous ions. *J. Biol. Chem.* 238:828-835 (1963).
20. Huuskonen, M.S., Tossavainen, A., Koshinen, H., Zitting, A., Korhonen, O., Nickels, J., Korhonen, K., Vaaronen, V.: Wollastonite exposure and lung fibrosis. *Environ. Res.* 30:291-304 (1983).
21. *In vitro effects of mineral dust*: pp 483-488, E.G. Beck & J. Bignon eds., Springer-Verlag, New York, Tokyo (1985).
22. Johannesen, K., Depierre, J.W., Borgstrone, A., Dallner, G., Erester, L.: Preparation and characterization of total rough and smooth microsome from the lungs of control and methylcholanthrene treated rats. *Biochem. Biophys. Acta.* 496:115-135 (1977).
23. Kallistractos, G., Fasske, E.: Inhibition of benzo(a)pyrene carcinogenesis in rat with vitamin C. *J. Cancer Res. Clin. Oncol.* 97:91-96, (1980).
24. King, H.W.S., Osborne, M.R., Brookes, P.: The *in vitro* and *in vivo* reaction at the N-7 position of guanine of the ultimate carcinogens derived from benzo(a)pyrene. *Chem. Biol. Interact.* 24:345-353 (1979).
25. Korhonen, K., Tossavainen, A.: Wollastonitti-Kuituinen teolisuumineraali (wollastonite—a fibrous industrial mineral) vuoriteollisuus. 39:38-45, (1981).
26. Lake, B.G., Harris, R.A., Philips, J.C., Gangolli, S.D.: Studies on the effects of L-ascorbic acid on acetaminophen-induced hepatotoxicity. *Toxicol. Appl. Pharmacol.* 60:229-235 (1981).
27. Lowry, O.H., Rosenbrough, N.J., Farr, A.L., Randall, R.J.: Colorimetric determination of protein with Folin Phenol reagent. *J. Biol. Chem.* 193:265-275 (1951).
28. Matkowics, B., Barabas, K., Sizabo, L., Beresicsi, G.: *In vitro* mechanisms of protective effects of ascorbic acid and reduced glutathione in paraquat poisoning. *Gen. Pharmacol.* 11:61-75 (1980).
29. Mossman, B.T., Landesman, J.M.: Importance of oxygen free radicals in asbestos—induced injury to airway epithelial cells. *Chest* 83:50-55 (1983).
30. Mossman, B.T., Light, W., Wei, E.: Asbestos: Mechanism of toxicity and carcinogenicity in the respiratory tract. *Am. Rev. Pharmacol. Toxicol.* 23:595-615 (1983).
31. Omura, T., Sato, R.: The carbon monoxide binding pigment of liver microsomes. *J. Biol. Chem.* 239:2379-2385 (1984).
32. Otolenghi, A.: Interaction of ascorbic acid and mitochondrial lipids. *Arch. Biochem. Biophys.* 79:355-360 (1959).
33. Rahman, Q., Narang, S., Kaw, J.L., Zaidi, S.H.: Asbestos induced hemolysis in relation to its silica solubility. *Environ. Physiol. Biochem.* 4:284-288 (1974).
34. Schaffert, R.R., Kingsley, G.R.: A rapid and simple method for the determination of reduced dehydro and total ascorbic acid in biological material. *J. Biol. Chem.* 212: 59-88 (1955).
35. Selikoff, I.J., Lee, D.H.K.: *Asbestos and disease*, pp 37-39, Academic Press, New York. (1978).
36. Shah, G.M., Bhattacharya, R.K.: *In vitro* effects of L-ascorbic acid on benzo(a)pyrene metabolite-DNA adduct formation in rat liver. *J. Biosci.* 4:263-270 (1982).
37. Singh, S.V., Viswanathan, P.N., Rahman, Q.: Interaction between plasma membrane and silicate dusts. *Environ. Hlth. Prospect.* 51:55-60 (1983).
38. Skaug, V., Gyseth, B.: Hemolytic activity of five different calcium silicates. *Environ. Hlth. Prospect.* 51:195-203 (1983).
39. Slaga, I.J., Bracken, W.N.: The effects of antioxidants on skin tumor initiation and aryl hydrocarbon hydroxylase. *Cancer Res.* 37:1631-1631 (1977).
40. Speier, J.L., Lam, L.K., Wattenberg, L.W.: Effect of administration to mice of butylated hydroxyanisole by oral inhibition on benzo(a)pyrene induced pulmonary adenoma formation and metabolism of benzo(a)pyrene. *J. Natl. Cancer Res.* 60:605-609 (1978).
41. Stegmann, H.: Microdetermination of hydroxyproline with chloramine-T and p-dimethyl amino benzaldehyde. *Hoppe-Seyler. Z. Physiol. Chem.* 311:41-45 (1958).
42. Wattenberg, L.W.: Induction of neoplasm by minor dietary constituents. *Cancer. Res.* 43:2448-2453 (1983).
43. Zaidi, S.H.: *Experimental pneumoconiosis*, pp. 94-106, John Hopkins Press, Baltimore (1969).

Figures 8-11 not provided

STUDY OF EFFECT OF DIFFERENT KIND OF SHORT ASBESTOS ON LUNG OF RATS

YANG MEIYU • Zhao Jinduo • Ku Guihau • Zhao Xiuqing • Fu Bo • Zhang Jifang

Shenyang Research Institute of Industrial Hygiene and Occupational Disease, Shenyang, P.R. China

Asbestos has many properties which include acid and alkali resistance, fire resistance, and ability of electric resistance which make it indispensable in modern industry. It is well known that inhalation of asbestos dust can lead to pulmonary fibrosis and carcinoma of the lung or to the development of diffuse mesothelioma of the pleura and peritoneum. But the mechanism of asbestos carcinogenesis is not clear. Some authors believe that asbestos carcinogenesis depends on chemical action. Other authors think that the physical nature of asbestos fibre is the main factor. Especially long fibre asbestos is the main reason for either fibrosis or tumors of lung. In order to elucidate hazards of short asbestos fibre, an experiment study of effects of four kinds of short asbestos on lungs of rats was observed. (Figures 1-4)

MATERIALS AND METHODS

Dust

Chrysotile and crocidolite were obtained from a Shenyang asbestos processing factory and Qingdao No. 2 asbestos processing factory respectively. Tremolite and actinolite were obtained from mining department of a college. These fibres were prepared by grinding in a ceramic ball mill. The length and diameter distribution of these fibres were obtained by phase-contrast microscopy as in Table I. Morphology of fibres was observed by electron micrograph.

Animals

Wistar rats were used. Weights of rats were 180-220g with nearly equal number of male and female rats. They were divided into 5 groups: chrysotile, crocidolite, tremolite, actinolite and saline control group. There were seventy rats in each group. All rats were injected intratracheally with 20mg dusts suspended in 1 ml saline; one month later they were injected repeatedly with suspended dust of same dose. Total dose was 40 mg in each rat. Some rats were killed at the end of 2, 4, 6, 12 and 18 months respectively after the initial injection of dust. The one third rats were allowed to live out their full lifetime. The living condition of rats was observed. The body weight of rats was measured every other month. The wet and dry weight and collagen content of the lungs were determined. The lungs and hilar nodes were examined. The native death and the development of pulmonary neoplasms of the one third rats were observed.

RESULTS

The body weight of all the animals were increasing with time. There was no difference significantly among the experimental and control groups. The dry weights of lungs of rats in all groups are shown in Figure 5.

The increasing of wet weight and collagen of lungs was similar to that of dry weight of lungs, during the sixth to twelfth months after onset of injection dust. There was significant increasing of collagen in the lung. There was significant difference among experimental and control groups. The increasing of collagen in chrysotile group was the highest among the experimental groups as in Table II.

PATHOLOGY

Gross

There were a lot of small grey-white or brown-tan spots at the surface of lungs in every group, after 2-4 months of injection dust. In the crocidolite group, the spots often were grey-blue in color. There were obvious spots at the cut surface and slight pulmonary emphysema after 6-12 months. Lymph nodes in the experimental groups were larger and harder than those of control group, especially in the chrysotile group.

Microscopic Appearance

Chrysotile group: after 2-4 months, a lot of macrophages, dust cell, asbestos fibres and debris were seen in alveoli adjacent to respiratory bronchioles and there was increasing of reticulate fibre, thickness of bronchioles and arteriolas wall (Figures 6, 7). During 6-12 months, there was slight pulmonary emphysema, a few collagen fibres in the interstice (Figure 8). At the end of 18 months, these changes were similar to former. No asbestos bodies were found in the lungs. There were a few reticular fibres and dust in the lymph nodes (Figure 9).

In the tremolite and actinolite groups, pathologic changes were nearly the same and both slighter than chrysotile group (Figure 10).

Crocidolite group: Reaction of lung tissue was initially slighter than other experimental groups. Later there was also reticular fibres hyperplasia in pulmonary interstice.

At 18th months, the epithelium hyperplasia of bronchioles and alveolus in some rats was present in the crocidolite and chrysotile groups (Figure 11).

The incidence of pulmonary malignant tumor: The asbestos fibres produced pulmonary malignant tumor (the exclusion of spontaneous lymphoblastoma) in all experimental groups. No pulmonary malignant tumor happened in the control group. The first tumor was found in the chrysotile group; rat died after 15 months of injection dust. Later, two rats with cancer were found at 22 months after injection dust, two cases in the crocidolite group and one case in both tremolite and actinolite group separately, as in Table III and Figures 12, 13.

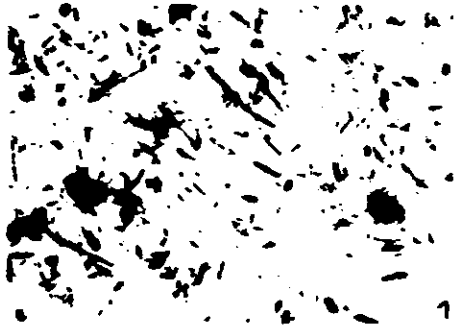

Figure 1. Electromicrograph of chrysotile ($\times 2500$).



Figure 3. Electromicrograph of tremolite ($\times 2500$).

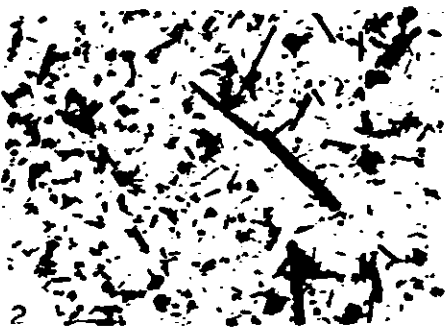

Figure 2. Electromicrograph of crocidolite ($\times 2500$).



Figure 4. Electromicrograph of actinolite ($\times 2500$).

Table I
Length and Diameter Distribution of Different Asbestos and SiO₂

Asbestos Fibre	Length of fibre(%)					Fibre in diameter (%)					SiO ₂ %
	<3	-5	-10	-20	>20	<1.2	-1.6	-2.5	-5	>5	
Chrysotile	76	15	6	2	1	100					0.31
Crocidolite	88	8	3	1	0		100				4.7
Tremolite	88	6	3	3	0	19	55	20	4	2	0.13
Actinolite	76	14	7	2	1	26	55	11	6	2	0.34

Table II
Result of Collagen Content of Lungs in Every Group

Group	2		4		6		12		18	
	No. (T)	$\bar{X} \pm S.E. (P)$	No. (T)	$\bar{X} \pm S.E. (P)$	No. (T)	$\bar{X} \pm S.E. (P)$	No. (T)	$\bar{X} \pm S.E. (P)$	No. (T)	$\bar{X} \pm S.E. (P)$
Cont	5	45.79 5.04	7	48.15 3.22	6	54.98 2.94	8	57.17 2.31	7	71.94 4.80
Chr	4	53.66 3.74	5	68.40 6.40 (2.49, <0.05)	4	81.78 2.20 (6.59, <0.001)	8	80.10 1.40 (3.08, <0.01)	7	85.86 5.10
Cro	4	35.59 2.70	6	48.64 2.33	6	55.89 3.37	8	72.26 6.29 (2.25, <0.05)	7	78.05 4.14
Tre	4	49.20 3.88	5	53.30 6.46	6	69.30 3.93	8	71.20 4.21 (2.93, <0.01)	8	77.23 5.0
Act	5	40.37 2.03	6	59.78 3.64 (2.32, <0.05)	5	71.71 6.70 (2.761, <0.05)	5	78.07 10.67 (2.396, <0.05)	6	79.10 5.18

Table III
Pathologic Type and Time of Inducing Tumor

Group	No. of Animals	No. of Pulmonary Tumors	Time (Months)							
			15	17	19	21	23	25	27	
Chrysotile	38	3	sq					Fibro		Adeno
Crocidolite	39	2		Adeno				Fibro		
Tremolite	40	1						Adeno		
Actinolite	35	1				sq				
Control	38	0								

Sq, Squamous cell carcinoma;
Fibro, Fibrosarcoma;
Adeno, Adenocarcinoma;

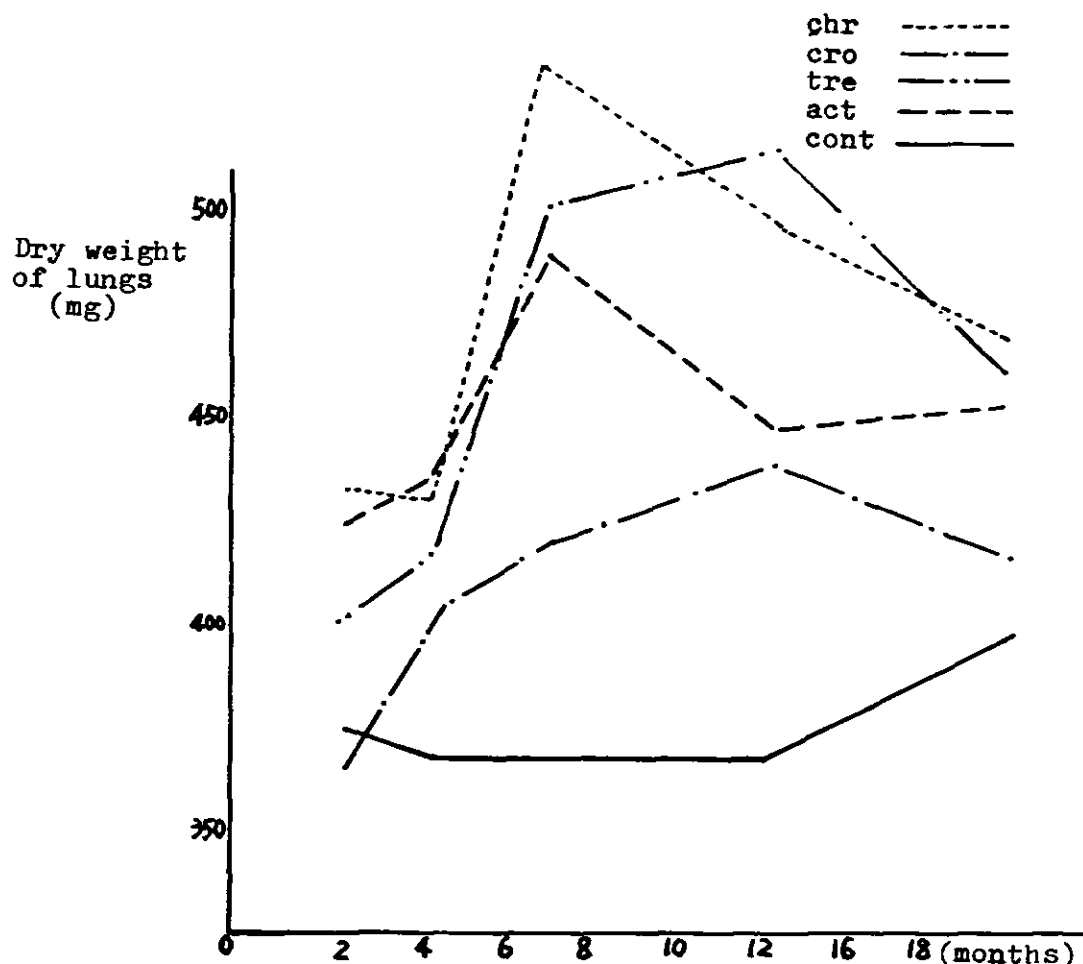

Figure 5. Changes of dry weight of lung in rats of every group.

DISCUSSION

For the different types of asbestos or the same asbestos type in different area, inhalation or injection asbestos can lead to various reaction of lung in the animal.^{1,2,3} In addition inhalation of same asbestos in different kinds of animals produced also various results. All four short asbestos in the experiment produced increasing of wet and dry weight of lung in rats. A lot of reticular fibres and a few collagen were found in the pulmonary interstice. These results correspond to Fu Shao Chang's report.^{4,5,6}

Inhalation or injection of asbestos fibres may produce pulmonary tumors.^{7,8,9} Seven rats with lung tumors in this experiment, the first lung tumor was found in a rat that had died at the 15th month after initial injection of chrysotile fibres. Most tumors were found during 21-25 months. No cancer happened in the control group. This experiment indicated that short asbestos fibres produced not only pulmonary fibrosis but also pulmonary cancer. This result corresponds with Gross's report. Besides, epithelium hyperplasia of bronchioles and alveoli was sometimes present. There changes were not seen in the control group. It seems possible that

pulmonary malignant tumors resulted from these changes.

Therefore, we hold that the effect of short fibre asbestos must be considered as recommended hygienic standard.

REFERENCES

1. Wagner, J.C., et al: Asbestosis in Experimental Animals. *Brit. J. Ind. Med.* 20:1-12 (1963).
2. Cooper, W.C., et al: Asbestos as a Hazard to Health. *Brit. Arch. Environ. Health* 15:285-289 (1967).
3. Gross, Paul, et al: Experimental Asbestosis. *Arch. Environ. Health* 15:343-355 (1967).
4. Fu Shaochang, et al: Experimental Study of the Effect of Asbestos on Lung of Rats. *J. Hyg. Res.* 10:118 (1981).
5. Zhu Huilan, et al: An Experimental Study of Crocidolite-induced Fibrosis of Rat Lung. *Chinese J. Ind. Hyg. Occup. Dis.* 3:279-281 (1985).
6. Li Hongyang, et al: Pathological Changes of Lungs in Dogs Exposed to Asbestos under Mining Condition. *Chinese J. Ind. Hyg. Occup. Dis.* 2:138-141 (1984).
7. Wagner, J.C., et al: The Effect of the Inhalation of Asbestos in Rats. *Brit. J. Cancer* 29:252 (1974).
8. Shabad, L.M., et al: Experimental Studies on Asbestos Carcinogenicity. *J. Natl. Cancer Inst.* 52:1175-1187 (1974).
9. Davis, J.M.G., et al: Mass and Number of Fibres in the Pathogenesis of Asbestos-related Lung Disease in Rat. *Chinese J. Ind. Hyg. Occup. Dis.* 2:138-141 (1984).

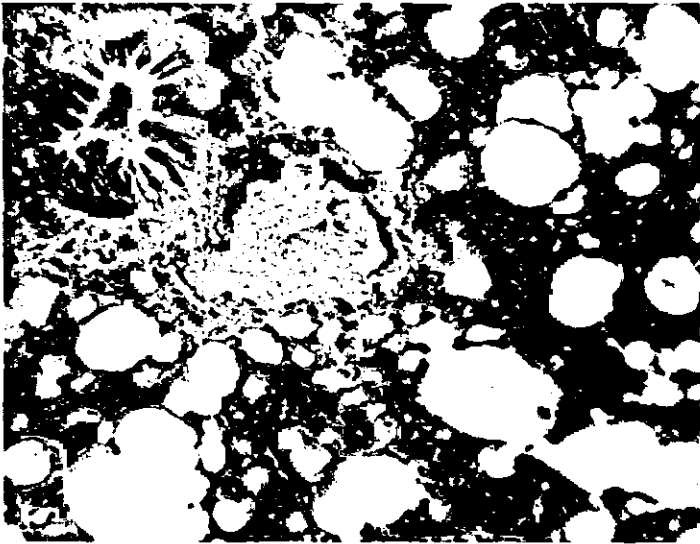

Figure 6. Chrysotile: Extensive areas of reticular fibre abutting on the terminal bronchioles and involving respiratory bronchioles. At the 2 months after injection of dust (H.E. $\times 78$).

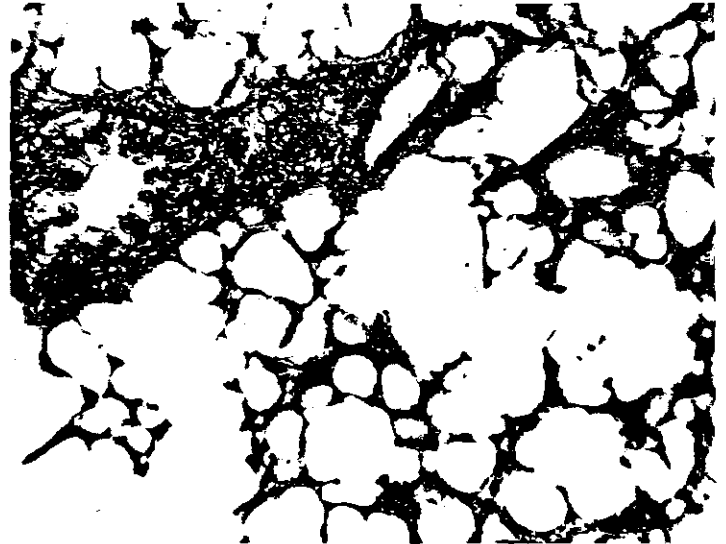

Figure 8. Chrysotile: Slight centrilobular emphysema and slight thickening of alveolar wall in different areas of the lungs. 6 months (G.S. $\times 78$).

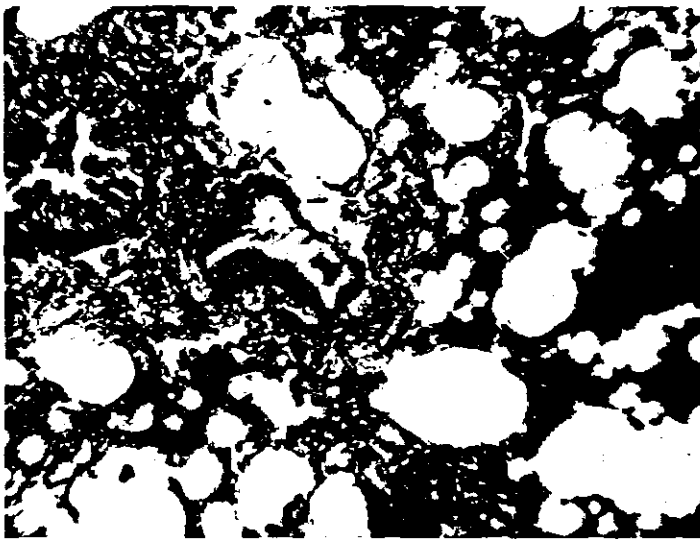

Figure 7. Bid (G.S. $\times 78$).

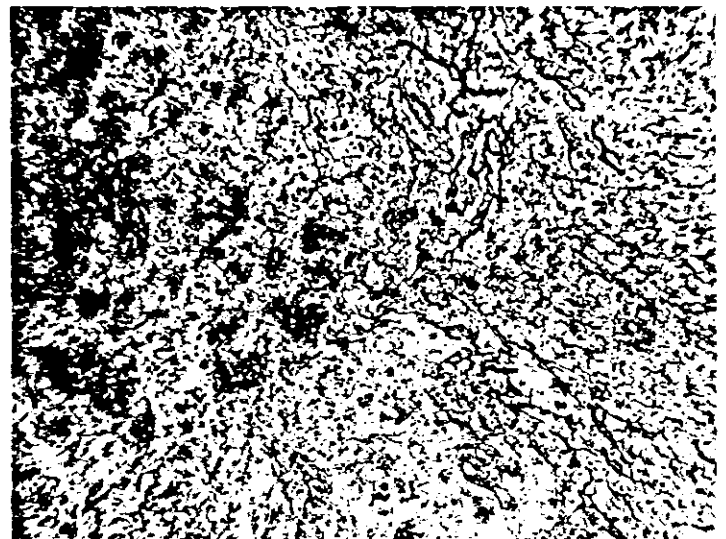

Figure 9. Chrysotile lymph node: Many more reticular fibres. 18 months (G.S. $\times 78$).

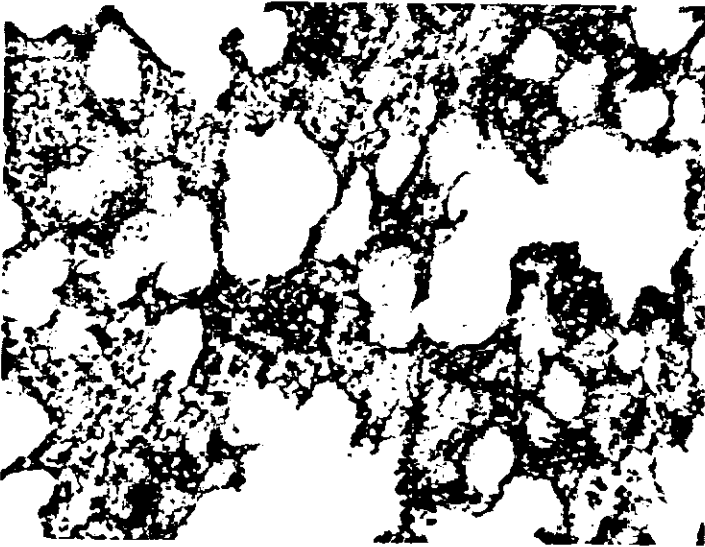

Figure 10. Tremolite: Extensive reticular fibres in pulmonary interstice. 12 months. (G.S. \times 78).

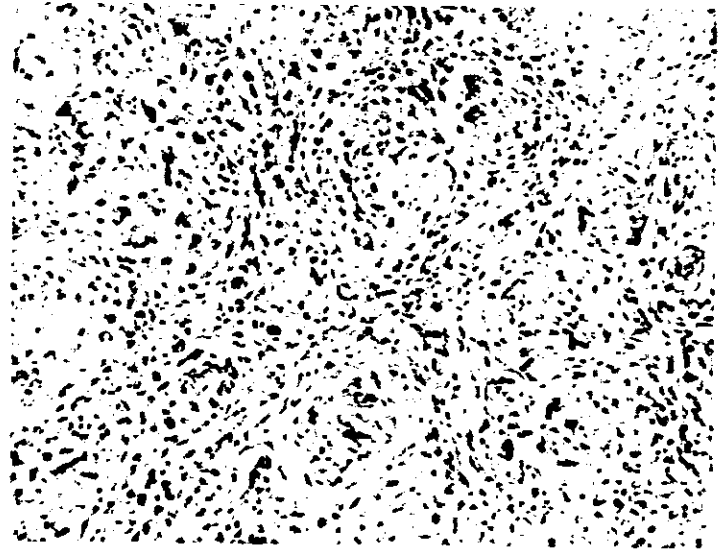

Figure 12. Chrysotile: Squamous cell carcinoma. 15 months (H.E. \times 78).

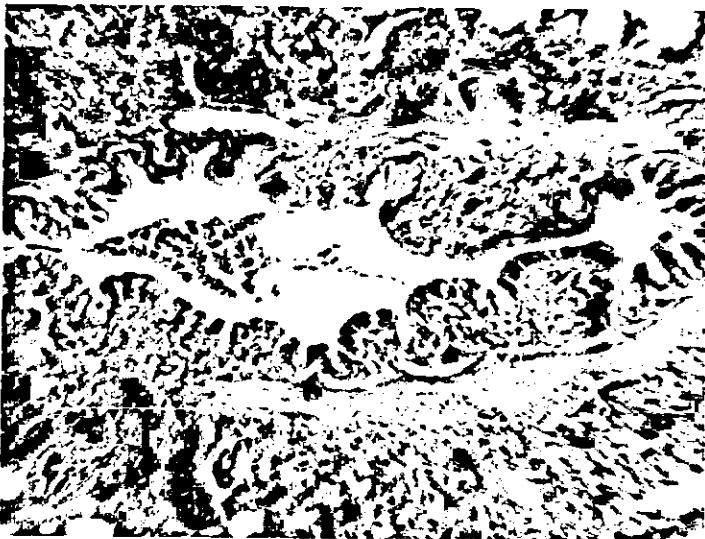

Figure 11. Chrysotile: Epithelium hyperplasia of bronchioles. 18 months (H.E. \times 120).

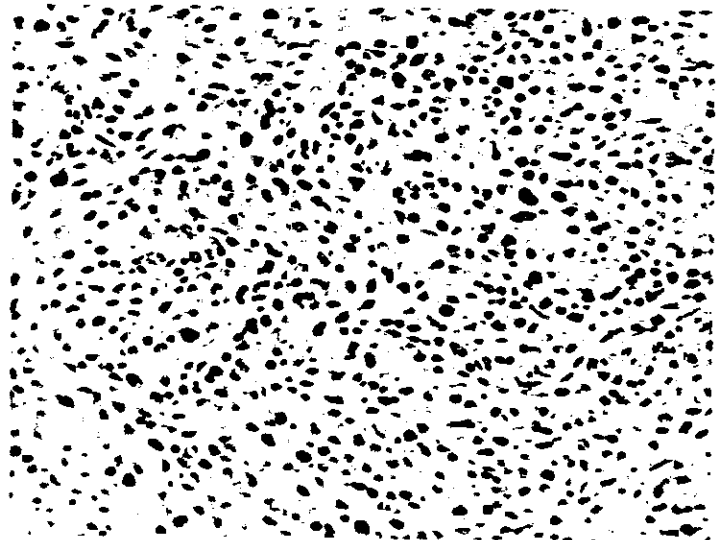

Figure 13. Chrysotile: Fibrosarcoma. 22 months (H.E. \times 78).

ACUTE TOXICITY OF FLY ASH COLLECTED FROM A MUNICIPAL INCINERATOR BURNING TRASH

Y. ALARIE • M. Iwasaki • M. Stock • R.C. Pearson • D.J. Lisk

Graduate School of Public Health, University of Pittsburgh Pittsburgh, PA, and Toxic Chemicals Laboratory, Cornell University, Ithaca, NY, USA

INTRODUCTION

There are about 70 operating municipal refuse incinerators in the United States and about 250 more are planned. The ash produced typically contains high concentrations of heavy metals¹ and a wide range of toxic organics including polychlorinated dibenzodioxins and dibenzofurans.² Therefore, there is a concern about possible health effects of the ash among those residing downwind from such incinerators as well as on workers within the plants. We have undertaken some preliminary studies with exposures of guinea pigs to very high concentrations of fly ash collected from one municipal refuse incinerator.

Experimental

Twenty kilograms of fly ash was collected from a municipal incinerator. After drying and mixing the ash was analyzed for cadmium, lead and zinc by wet ashing with nitric and perchloric acids followed by anodic stripping voltametry.³ Mercury was determined by flameless atomic absorption analysis.⁴

The ash was placed into a Pitt No. 3 aerosol generator⁵ for resuspension in air of fine particles which were delivered to an exposure system for guinea pigs.^{6,7} This system consisted of a central glass chamber to which four glass chambers were attached, each holding one guinea pig. Each of these animal chambers functioned as a flow-through whole body plethysmograph.⁸ Therefore they permitted indirect measurement of tidal volume (VT), from the pressure changes (ΔP) created by each breath as monitored by a sensitive pressure transducer attached to each chamber.⁸ Four male Hartley guinea pigs (300-350g) were obtained from Hazleton Research Products, Inc. and were exposed to the ash 6 hours/day for 5 consecutive days. The exposure concentration was 314 mg/m³ and the particle size was 3.2 μ m mass aerodynamic diameter. Prior to and immediately following each exposure each animal was challenged with 10% CO₂ in 20% O₂ and 70% N₂. ΔP and respiratory frequency (f) were measured during air breathing and CO₂ challenge.^{8,9} Similar CO₂ challenges were also conducted on days 6-9, 14, 16, 21, 26-30, 35 and 50 following exposure. Euthanasia was performed on day 50 using pentobarbital. Kidneys, livers and lungs were removed. Lungs were fixed using intratracheal infusion of 10% buffered formaldehyde held at 25 cm H₂O for two hours prior to continued fixing in the same solution. Before and after fixation lung weights were taken and lung volumes were measured by water displacement. Four guinea

pigs were used as controls and treated as the exposed animals except that no dust was delivered to the exposure system.

RESULTS

Table I lists the heavy metals and carbon content of the ash and Table II lists the heavy metals found in tissues of guinea pigs 45 days after termination of exposure. Significant elevation was found in the lungs of the exposed animals as compared to the controls.

Following the first exposure and during the five exposure days there was no change from preexposure for VT measured during air breathing. However f was lower. During CO₂ challenge both VT and f were lower. This effect persisted for all exposure days. Measurements made after the 5 exposure days and until sacrifice at day 50 indicated recovery towards control values. However, there was histopathological findings in all animals ranging from moderate to severe pneumoconiosis. This consisted of interstitial macrophage reaction with a number of dense, black granule-laden macrophages. Airways were moderately constricted and a moderate degree of smooth muscle hypertrophy of the airways and vessels was present. Thickening of alveolar septa by macrophages and foci of granule-laden macrophages was observed. There was no increase in lung weights in comparison to the controls. Lung volumes after fixation were reduced by 50% in two animals, probably because of the constricted airways preventing the entry of fixative as in controls.

DISCUSSION

Fly ash from refuse incinerators will vary greatly because of the nature of the operation. Nevertheless, the results indicate that a very high concentration was needed to induce an abnormal ventilatory response to CO₂ on an acute basis. The reduction in VT during CO₂ was just below 50% of control. This level of effect can be induced by 13 mg/m³ of cotton dust,¹⁰ 1.5 mg/m³ of paraquat,¹¹ or 50 mg/m³ hexamethylene diisocyanate trimer.¹² Therefore the dust tested was not very potent in inducing an acute pulmonary effect. The delayed effects, as indicated from microscopic examination of the lungs were important and it would therefore be appropriate to investigate such dusts with repeated exposures at low concentrations to investigate the possible chronic effects. Airways constriction with smooth muscles hypertrophy suggest the possible development of chronic obstructive lung disease. This could be followed functionally by flow-volume measurements which can be made in guinea pigs.⁹

REFERENCES

1. Greenberg, R. R., Zoller, W. H. and Gordon, G. E.: Composition and Size Distributors of Particles Release in Refuse Incineration. *Environ. Sci. Technol.* 12:566-573 (1978).
2. Eiceman, G. A., Clement, R. E. and Karasek, F. W.: Analysis of Fly Ash From Municipal Incinerators for Trace Organic Compounds. *Anal. Chem.* 51:2343-2350 (1979).
3. Gajan, R. J. and Larry, D.: Determination of Lead in Fish by Atomic Absorption Spectrophotometry and Polarography, I. Development of the Methods. *J. Assoc. Off. Anal. Chem.* 55:727-732 (1972).
4. Hatch, W. R. and Ott, W. L.: Determination of Sub-microgram Quantities of Mercury by Atomic Absorption Spectrophotometry. *Anal. Chem.* 40:2085-2087 (1968).
5. Weyel, D. A., Ellakkani, M., Alarie, Y., and Karol, M.: An Aerosol Generator for the Resuspension of Cotton Dust. *Toxicol. Appl. Pharmacol.* 76:544-547 (1984).
6. Alarie, Y., Ferguson, J. S., Stock, M. F., Weyel, D. A., and Schaper, M.: Sensory and Pulmonary Irritation of Methyl Isocyanate in Mice and Pulmonary Irritation and Possible Cyanidelike Effects of Methyl Isocyanate in Guinea Pigs. *Environ. Health Perspect.* 72:159-167 (1987).
7. Ellakkani, M. A., Alarie, Y., Weyel, D., Mazumdar, S. and Karol, M. H.: Pulmonary Reactions to Inhaled Cotton Dust: An Animal Model for Byssinosis. *Toxicol. Appl. Pharmacol.* 74:267-284 (1984).
8. Wong, K. L., Alarie, Y.: A Method for Repeated Evaluation of Pulmonary Performance in Unanesthetized, Unrestrained Guinea Pigs and its Application to Detect Effects of Sulfuric Acid Mist Inhalation. *Toxicol. Appl. Pharmacol.* 63:72-90 (1982).
9. Alarie, Y and Schaper, M.: Pulmonary Performance in Laboratory Animals Exposed to Toxic Agents and Correlations with Lung Diseases in Humans. *Lung Biology in Health and Disease. Pathophysiology and Treatment of Inhalation Injuries*, pp 67-122. J. Loke, Ed. Dekker, N.Y. (1988).
10. Ellakkani, M. A., Alarie, Y., Weyel, D. A. and Karol, M. H.: Concentration-Dependent Respiratory Response of Guinea Pigs to a Single Exposure of Cotton Dust. *Toxicol. Appl. Pharmacol.* 80:357-366 (1985).
11. Burleigh-Flayer, H. and Alarie, Y.: Concentration-Dependent Respiratory Response of Guinea Pigs to Paraquat Aerosol. *Arch. Toxicol.* 59:391-396 (1987).
12. Ferguson, J. S., Schaper, M., Alarie, Y.: Pulmonary Effects of a Polyisocyanate Aerosol: Hexamethylene Diisocyanate Trimer (HD1t) or Desmodur N (DES-N). *Toxicol. Appl. Pharmacol.* 89:332-346 (1987).

Table I

Heavy Metals and Carbon Content of Collected Fly Ash for Exposure of Guinea Pigs. Concentration Given on the Basis of Dry Weight.

Item (units)	
Cadmium (ppm)	477
Lead (ppm)	2134
Mercury (ppm)	25
Zinc (ppm)	14301
Carbon (%)	7.34

Table II

Concentrations of Heavy Metals in Tissues of Guinea Pigs Exposed to Refuse Incinerator Fly Ash. Measurements Made 45 Days After 5 Daily Exposures of 6 Hours Each at an Exposure Concentration of 314 mg/m³

(Parts per million (dry weight of metal in tissue))

	Controls	Exposed
	^a	
Cadmium in lung	0.20 ± 0.02	1.45 ± 0.17
Cadmium in kidney	1.16 ± 0.22	1.91 ± 0.23
Cadmium in liver	0.41 ± 0.07	0.97 ± 0.11
Lead in lung	1.25 ± 0.22	6.58 ± 0.46
Lead in kidney	0.40 ± 0.06	0.62 ± 0.14
Lead in liver	0.23 ± 0.03	0.34 ± 0.03
Zinc in lung	68.50 ± 7.06	110.48 ± 5.63
Zinc in kidney	89.45 ± 4.18	94.39 ± 7.31
Zinc in liver	93.63 ± 6.12	115.48 ± 12.74
Mercury in lung	0.16 ± 0.04	0.32 ± 0.03

^a
Means ± standard error.

ASBESTOS RELATED DIFFUSE PLEURAL FIBROSIS

A.R. GIBBS,* MB, ChB, MRC Path. • D.M. Griffiths† • M. Stephens,‡ MB, BCh •
F.D. Pooley,§ Ph.D., MIMM., MAIME., C Eng.

*Department of Pathology, Llandough Hospital, Penarth

†Medical Research Council External Staff on Occupational Lung Disease, Llandough Hospital, Penarth

‡Department of Pathology, University Hospital, Nottingham

§Institute of Materials, University College, Cardiff

Diffuse pleural fibrosis (DPF), particularly when severe may cause reduction in vital capacity and contribute to respiratory disability.¹ Recently DPF has been accepted as a consequence of asbestos exposure.^{2,3} We previously studied 7 cases of asbestos related DPF and reported on the pathological and mineralogical findings.⁴ In this study we have extended these observations to 13 cases and also performed mineralogical analysis on tissues sampled from the central, subpleural and pleural regions of the lung. The aims of the study were to investigate the type of occupational exposure, the total mineral fibre burdens and the type and distribution of asbestos mineral fibres within the lungs associated with this form of asbestos related disease.

METHODS

The 13 cases were selected on the basis that there was a history of asbestos exposure and at autopsy the DPF was bilateral, covered more than 25% of the lung surface and exceeded 5 mm in thickness at some points. Clinical and occupational histories were obtained from the hospital notes or Medical Boarding Centres. At least one of the lungs was inflated and tissue blocks were taken for histology as follows:

1. Subpleural region of the apex of upper lobe.
2. Subpleural region of the apex of lower lobe.
3. Subpleural region of the base of lower lobe.
4. Central region of the upper lobe.
5. Central region of the lower lobe.
6. Several blocks from areas of pleural fibrosis.

The degree of parenchymal fibrosis was graded from 0 to 4 for each histological slide by an established system and an average value obtained for each case.^{5,6}

For mineralogical examination samples were taken from the same areas. The mineralogical analysis was performed for the subpleural region by pooling samples adjacent to blocks 1-3, for the central region by pooling the samples adjacent to blocks 4 and 5 and the pleura by pooling the samples adjacent to the blocks from 6. The samples were divided into two, and one from each of the areas was dried to a constant weight so that the wet/dry ratio could be calculated. The remaining portions were digested in a wet state by 40% potassium hydroxide. For light microscopy: after centrifugation, the sediment was

examined in a Fuchs Rosenthal chamber by phase contrast and the number of fibres and bodies counted, from which could be calculated the number per gramme of dried lung.⁷ At least 100 asbestos forms were counted. For electron microscopical examination: following digestion, the final deposits were ashed at 300C for 4 hours. The suspensions were then passed through 0.2 pore sized nucleopore filters.

They were then carbon coated and examined by transmission electron microscopy. The fibres were identified by type and the number per gramme of dried lung calculated. At least 200 fibres were counted and identified for each sample. Statistical analysis was performed using the Wilcoxon ranking test for paired data.

RESULTS

The occupational details for each case are given in Table I. All were males and the age at death ranged from 47 to 80 years. Duration of exposure to asbestos varied from 1 to 35 years. In all cases macroscopical examination revealed extensive diffuse visceral pleural fibrosis which was at least greater than 5 mm but which went up to 4 cm in thickness and mimicked pleural mesothelioma in some cases. In several cases there were extensive adhesions between the visceral and parietal pleura. In some cases recognisable parietal pleural plaques were also present. Case 10 also showed severe diffuse pericardial fibrosis similar to that of the pleura. Microscopically the pleura showed mature collagen arranged in a basket weave pattern. The degree of pulmonary fibrosis for each case is given in Table I.

Total mineral fibre counts obtained by light and electron microscopy at the central, subpleural and pleural sites are given for each subject in Table II. Table III shows the mean total and specific fibre counts for each of the anatomical sites.

The total asbestos fibre count was significantly greater in the central and subpleural region than in the pleura ($p < 0.01$). There were no significant differences in the distribution of chrysotile in the central, subpleural or pleural regions but there was a statistically significant difference in the distribution of amosite and crocidolite ($p < 0.01$). The amosite and crocidolite levels were much lower in the pleura than in the other regions.

Table I
 Ages, Occupational Histories and Histological Fibrosis Grades
 of 13 Cases of DPF with a History of Asbestos Exposure

SUBJECT	AGE/YRS	OCCUPATIONAL HISTORY	GRADE OF PULMONARY FIBROSIS
1	80	Pipe fitter 25 yrs	2
2	67	Engineer, 2 yrs cutting asbestos sheets	2/3
3	64	Boiler maker	1/2
4	75	Electrical welder	2
5	71	Carpenter, cutting roofing sheets	1/2
6	64	Asbestos sprayer	2/3
7	62	Boiler lagger for 33 years	1
8	64	Unloaded asbestos from sacks (4 yrs) and production of refractory slab (7 yrs)	2
9	47	Mixing and moulding blue asbestos for battery moulds for 1 yr	0/1
10	69	Marine engine fitter 35 yrs	ND
11	54	Gas fitter and plumber	0/1
12	75	Refitting ships 25 yrs	1
13	74	Ship yard joiner	2/3

DISCUSSION

We consider that the DPF in 11 of these cases is likely to have been caused by asbestos but in two it is debatable. Subject 13 had been treated for pulmonary tuberculosis nine months prior to death; the lungs showed quite severe fibrosis and very low asbestos fibre counts which were well within the range of our normal controls. Tuberculosis therefore seems the most likely cause of the pleural fibrosis in this case. Subject 11 had a very vague history of asbestos exposure and the lung asbestos counts were well within the normal control levels. The cause in this case is unknown but unlikely to be due to asbestos.

The light and electron microscopical mineral fibre counts

showed a good correlation with each other but the light microscopical counts were in general two orders of magnitude lower than the electron microscopical counts. Although light visible counts obtained by phase contrast cannot give an accurate value for total lung asbestos burden, they are a useful indicator of amphibole exposure.^{9,10} Small thin fibres are not visible by this method. Nevertheless, the method is inexpensive, quick and more widely available than EM analysis and in this group of cases the LM counts appeared to be a useful indicator of whether the DPF was likely to have been asbestos induced.

The total counts were generally raised above normal and in

Table II
Total Fibre Counts Obtained by LM and EM Analysis in the Central (C), Subpleural (S), and Pleural (P) Regions of the Lung

SUBJECT	LM (X 10 ³)			EM (X 10 ⁶)		
	C	S	P	C	S	P
1	102.8	76.5	5.7	10.7	25.5	2.0
2	232.7	105.5	26.7	8.4	19.0	9.2
3	79.4	131.0	7.0	18.0	19.1	7.5
4	55.6	88.5	0.65	ND	ND	ND
5	68.4	66.5	0.83	18.9	12.2	2.2
6	95000.0	5700.0	306.0	24769.5	32722.3	123.5
7	5330.0	4200.0	0	143.3	124.7	10.1
8	1210.0	1800.0	3.7	162.8	225.0	11.0
9	48.5	100.0	0	15.4	40.6	2.5
10	ND	744.0	11.5	18.6	80.3	17.0
11	12.2	7.7	3.1	21.9	13.1	3.3
12	7000.0	2500.0	0	93.9	164.5	2.1
13	0	25.0	0	26.1	32.4	13.2

Table III
Geometric (Arithmetic) Mean Asbestos Fibre Counts by Type in the Central (C), Subpleural (S) and Pleural (P) Regions of the Lung (10^6)

	Total Asbestos fibres	Chrysotile	Crocidolite	Amosite
C	36.8 (2009.3)	5.24 (9.5)	5.2 (1907.9)	6.6 (182.9)
S	50.4 (2776.5)	13.3 (56.3)	4.9 (2559.0)	7.4 (160.9)
P	6.7 (16.2)	5.5 (7.7)	0.15 (7.4)	0.05 (1.1)

the range we have seen with pleural plaques and minimal asbestosis. However, three subjects had counts which were well above this range (subjects 6, 7 and 12). Subject 6 had an extremely high count, which we have usually encountered in severe asbestosis; he was an asbestos sprayer, an occupation which may be associated with very high asbestos exposures.

The counts obtained at the various sites within the lung confirm the nonuniform distribution of asbestos as shown by others.¹¹ Chrysotile parenchymal levels were similar to normal controls except for subject 6. Amphibole parenchymal levels were raised above normal in all but two (subjects 11 and 13) which we consider unlikely to be caused by asbestos. The pleura contained relatively little fibre and by far the majority of this was chrysotile. Sebastien et al¹² in a previous study of asbestos fibres from the lung parenchyma and pleura of cases suffering from a variety of asbestos related diseases, found no relationship between parenchymal and pleura concentrations and the pleura contained almost exclusively chrysotile. Although amphibole fibres were found in the pleura of all but one of our cases, they were extremely sparse in number.

In conclusion the findings of this study confirm previous observations that the distribution of fibres within the lung is not uniform. It also shows that in these cases of DPF the majority of fibre within the pleura is chrysotile but small numbers of amphibole fibres are also present. Also the amount of amphibole fibres within the pleura is much less than that in the parenchyma. As in other asbestos related diseases the parenchymal levels of amphibole asbestos but not chrysotile appear raised above controls.

REFERENCES

1. Britton, M.G.: Asbestos pleural disease. *Br. J. Dis. Chest* 76:1-10 (1982).
2. Davis, D.: Asbestos related diseases without asbestosis. *Br. Med. J.* 287:164 (1983).
3. McLoud, T.C., Woods, B.O., Carrington, C.B., Epler, G.R., Gaensler, E.A.: Diffuse pleural thickening in an asbestos exposed population. *A.J.R.* 144:9-18 (1985).
4. Stephens, M., Gibbs, A.R., Pooley, F.D., Wagner, J.C.: Asbestos induced diffuse pleural fibrosis: pathology and mineralogy. *Thorax* 42:583-588 (1987).
5. Hinson, K.F.W., Otto, H., Webster, I., Rossiter, C.E.: Criteria for the diagnosis and grading of asbestosis. In: *Biological Effects of Asbestos*, pp 54-57. P. Bogovski, Ed. W.H.O., Lyons, France (1973).
6. Craighead, J.E., Abraham, J.L., Churg, A., Green, F.H.Y., Kleinerman, J., Pratt, P.C., Seemayer, T.A., Vallyathan, V., Weill, H.: Asbestos associated diseases. Report of the pneumoconiosis committee of the College of American Pathologists and National Institute for Occupational Safety and Health. *Arch. Pathol. Lab. Med.* 106:541-595 (1982).
7. Ashcroft, T., Heppleston, A.G.: The optical and electron microscopic determination of pulmonary asbestos fibre concentration and its relation to the human pathological reaction. *J. Clin. Pathol.* 23:224-234 (1973).
8. Pooley, F.D., Clarke, N.J.: Quantitative assessment of inorganic fibrous particles in dust samples with an analytical transmission electron microscope. *Ann. Occup. Hyg.* 22:253-271 (1979).
9. Churg, A., Warnock, M.L.: Analysis of the cores of asbestos bodies from members of the general population; patients with probable low degree exposure to asbestos. *Am. Rev. Respir. Dis.* 120:781-786 (1979).
10. Pooley, F.D.: Asbestos bodies, their formation, composition and character. *Environ. Res.* 5:363-379 (1972).
11. Churg, A., Wood, P.: Observations on the distribution of asbestos fibres in human lungs. *Environ. Res.* 31:374-380 (1983).
12. Sebastien, P., Janson, X., Gaudichet, A., Hirsch, A., Bignon, J.: Asbestos retention in human respiratory tissues. Comparative measurements in lung parenchyma and in parietal pleura. In: *Biological Effects of Mineral Fibres*, pp 237-246. J.C. Wagner, Ed. IARC, Lyons, France (1980).

ACKNOWLEDGEMENTS: We wish to thank Professor J.S.P. Jones for information and access to the material for several of the cases.

HYALINE PLEURAL PLAQUES AND ASBESTOS EXPOSURE

C. BIANCHI • A. Broilo • L. Ramani

Laboratory of Pathological Anatomy, Hospital of Monfalcone, Monfalcone, Italy

INTRODUCTION

The importance of hyaline pleural plaques as possible markers of previous exposure to asbestos and to other mineral fibres, is now recognized.^{1,2,11,12} In the present study the characteristics of pleural plaques have been analyzed in a series of necropsies, carried out in Monfalcone, Italy. The first results of this investigation have been the object of previous papers.³⁻⁷

MATERIALS AND METHODS

The Territory of Monfalcone is a small industrial district, in northeastern Italy, at the border with Yugoslavia. It covers an area of 152 square kilometers and has a population of 59,599 (1981 census). The Monfalcone Territory includes eight towns, the major of which are Monfalcone (30,259 inhabitants), and Ronchi dei Legionari (10,052 inhabitants).

The Monfalcone shipyard, opened at the beginning of this century (1908), is the most important industry in this area. At present about 3,000 persons are employed in the Monfalcone shipyard; but the workforce was greater in the past, having reached nearly 10,000 workers in the late 1930's.

During the period October 1979-December 1987 a total of 1,620 necropsies were performed at the Monfalcone Hospital. The necropsies were carried out by three pathologists (Claudio Bianchi, Lucia Bittesini, and Alessandro Broilo). In all the cases a careful inspection of the thoracic cavities was performed, in order to detect the presence of hyaline pleural plaques. In a large majority of the necropsies, the costal and the diaphragmatic pleuras were detached from the thoracic cavity, placed on a table, and then examined. All white, fibrous patches, calcified or not, involving parietal pleura were defined as pleural plaques. Unilateral and very small patches were also considered as hyaline plaques. The cases with pleural plaques were classified in 3 classes: (1) mild, (2) moderate, and (3) severe, on the basis of the size of plaques. Small plaques (few centimeters in major diameter) were classified as mild, while very large unilateral and bilateral plaques involving the major part of a hemithorax were defined as severe. The term moderate was applied to the intermediate conditions. In expressing the results, a simplified classification ("small" and "large") is sometimes adopted, "small" corresponding to class 1, and "large" including the remaining two classes.

In a number of cases the macroscopic features of pleural plaques were photographically documented. Moreover samples were generally obtained from the pleura for

histological examination.

In all the cases a sample, measuring about 3x3x2 centimeters, was taken from the lung base and formalin fixed. The piece was taken from the right lung, or from the left base when the right was largely involved by tumor. In 464 cases the sample was completely digested in a commercial 5% sodium hypochlorite solution. Asbestos bodies were then isolated and quantitated according to the method of Smith and Naylor.¹⁶ The results were expressed as the number of asbestos bodies per gram of dried lung tissue.

In 745 cases the patients' relatives were interviewed to obtain detailed occupational data. Generally the interviews were carried out at our laboratory by one of us (C.B.). In some cases the interviewer was another doctor of our staff, and in a few cases telephone interviews were performed. The questions concerned the various occupations of the patient, the place and the time of the activities, and the occupations of his/her relatives. When sufficient information was not obtained, further members of the family were interviewed. In many cases the "work-book" (a personal document in which all the occupations and the names of employers are listed) was consulted.

The chi-square test was used to compare the prevalence of pleural plaques among the various groups of patients. The relation between pleural plaques and asbestos body content was examined by determination of the Spearman's correlation coefficient.

RESULTS

The series consisted of 1,040 men and 580 women. Tables I and II show the sex and age distribution of pleural plaques. Between the two sexes there were significant differences in the prevalences of total plaques ($p < 0.001$), small plaques ($p < 0.01$), and the large plaques ($p < 0.001$).

In Table III the patients are subdivided according to sex, and place of residence at death. The men resident in Monfalcone Territory more frequently showed pleural plaques ($p < 0.001$) and large plaques ($p < 0.01$), compared with men resident in other areas. Among women higher prevalences of total plaques ($p < 0.001$) and of small plaques ($p < 0.01$) were observed in Monfalcone Territory residents.

The amounts of lung asbestos bodies showed marked differences between the two sexes (Table IV). A good correlation was visible between the amount of asbestos bodies and extent of pleural plaques (Table V) ($r = 0.61$, $p < 0.001$).

Table I
Hyaline Pleural Plaques and Age (Men)

Age (years)	No. of cases	Hyaline Pleural Plaques (%)			
		Absent	Class 1	Class 2	Class 3
0 - 24	13	100.0	0.0	0.0	0.0
25 - 34	4	75.0	0.0	25.0	0.0
35 - 44	24	29.2	33.3	12.5	25.0
45 - 54	99	34.3	20.2	21.2	24.2
55 - 64	209	31.6	26.8	19.1	22.5
65 - 74	327	27.5	24.8	24.8	22.9
75 - 84	305	26.2	23.3	28.2	22.3
85 - 94	59	37.3	22.0	22.0	18.6
Total	1040	30.3	23.9	23.6	22.2

Table II
Hyaline Pleural Plaques and Age (Women)

Age (years)	No. of cases	Hyaline Pleural Plaques (%)			
		Absent	Class 1	Class 2	Class 3
0 - 24	5	100.0	0.0	0.0	0.0
25 - 34	5	100.0	0.0	0.0	0.0
35 - 44	13	84.6	15.4	0.0	0.0
45 - 54	26	80.8	15.4	3.8	0.0
55 - 64	69	71.0	26.1	1.4	1.4
65 - 74	125	72.8	18.4	7.2	1.6
75 - 84	236	77.1	19.5	3.4	0.0
85 - 94	96	82.3	12.5	5.2	0.0
95 - 99	5	100.0	0.0	0.0	0.0
Total	580	77.2	18.1	4.1	0.5

Table III
Hyaline Pleural Plaques and Residence

	No. of cases	Hyaline Pleural Plaques (%)			
		Absent	Class 1	Class 2	Class 3
MEN					
MT Residents	872	25.8	23.6	25.5	25.1
Others	168	53.6	25.6	13.7	7.1
WOMEN					
MT Residents	468	73.9	20.5	4.9	0.6
Others	112	91.1	8.0	0.9	0.0

MT = Monfalcone Territory

Table VI shows the prevalence of pleural plaques in men classified on the basis of work history data. There were marked differences from one occupational category to another, with shipyard workers and clerks being at the two extremes. The subjects employed in industries (shipbuilding, chemical, construction, and various), showed a significantly higher prevalence of pleural plaques, compared with persons employed in agriculture ($p < 0.001$), or with persons included in the remaining groups ($p < 0.001$).

Among the chemical industry workers there were 18 patients, who had been employed in the sodium carbonate factory of Monfalcone; a very high prevalence of pleural plaques was observed in this subgroup, large plaques having been found in 14 cases, and small plaques in 3.

Among women a large number of patients had histories of household exposure to asbestos having cleaned the work

clothes of their family members employed in shipbuilding or in the chemical industry. A double classification of the cases had therefore been adopted, according to the presence (Table VII) or the absence (Table VIII) of data indicating domestic exposure. Eight women with incomplete histories have not been included in the tables. The women exposed to asbestos at home significantly differed from the others in the prevalence of pleural plaques ($p < 0.001$).

In a large majority of the cases the patients with pleural plaques and with histories of employment in the shipyard or in other industries, had begun their work before 1950. However, a small number of subjects, who had their first employment in the shipyard in the 1970's, were observed; these workers showed small plaques and widely variable amounts of lung asbestos bodies (between 100 and 200,000/g dried lung tissue).

Table IV
Asbestos Bodies Amounts in 464 Cases

AB *	MEN		WOMEN	
	Cases	%	Cases	%
0 - 1	6	1.6	4	4.4
1 - 2	16	4.3	14	15.6
2 - 3	80	21.4	37	41.1
3 - 4	108	28.9	31	34.4
4 - 5	118	31.6	3	3.3
5 - 6	40	10.7	1	1.1
6 - 7	6	1.6	0	0.0
Total	374	100.0	90	100.0

* Asbestos bodies, Log10 /g dried tissue

Table V
Hyaline Pleural Plaques and Lung Asbestos Bodies

AB *	No. of cases	Hyaline Pleural Plaques (%)			
		Absent	Class 1	Class 2	Class 3
0 - 1	10	60.0	40.0	0.0	0.0
1 - 2	30	60.0	26.7	13.3	0.0
2 - 3	117	41.9	37.6	15.4	5.1
3 - 4	139	28.8	18.7	25.2	27.3
4 - 5	121	7.4	11.6	33.1	47.9
5 - 6	41	0.0	9.8	26.8	63.4
6 - 7	6	16.7	0.0	0.0	83.3
Total	464	26.5	21.6	23.3	28.7

* Asbestos bodies, Log10 /g dried tissue

Table VI
Hyaline Pleural Plaques and Occupations (Men)

	No. of cases	Hyaline Pleural Plaques (%)			
		Absent	Class 1	Class 2	Class 3
Shipbuilding industry	141	7.1	22.0	33.3	37.6
Shipbuilding and others	217	18.4	18.9	25.8	36.9
Chemical industry	26	19.2	23.1	26.9	30.8
Sailors and dock workers	19	31.6	42.1	10.5	15.8
Various industries	46	50.0	21.7	19.6	8.7
Construction industry	33	54.5	27.3	9.1	9.1
Agriculture	26	61.5	30.8	7.7	0.0
Artisans and traders	24	66.7	25.0	8.3	0.0
Clerks	12	91.7	0.0	8.3	0.0
Other	11	63.6	27.3	0.0	9.1
Insufficient data	4	25.0	25.0	50.0	0.0
Total	559	27.4	22.0	23.4	27.2

Table VII
Hyaline Pleural Plaques and Occupations in Women with Histories of Domestic Asbestos Exposure

	No. of cases	Hyaline Pleural Plaques (%)			
		Absent	Class 1	Class 2	Class 3
Shipbuilding industry	9	22.2	77.8	0.0	0.0
Various industries	19	26.3	52.6	15.8	5.3
Housewives	24	33.3	54.2	12.5	0.0
Textile industry	14	50.0	35.7	14.3	0.0
Agriculture	20	55.0	30.0	15.0	0.0
Artisans and traders	18	61.1	38.9	0.0	0.0
Maids	11	63.6	27.3	9.1	0.0
Other	6	50.0	50.0	0.0	0.0
Total	121	44.6	44.6	9.9	0.8

Table VIII
Hyaline Pleural Plaques and Occupations in Women without History of Domestic Asbestos Exposure

	No. of cases	Hyaline Pleural Plaques (%)			
		Absent	Class 1	Class 2	Class 3
Various industries	2	50.0	0.0	0.0	50.0
Clerks	6	66.7	16.7	16.7	0.0
Shipbuilding industry	10	70.0	30.0	0.0	0.0
Textile industry	4	75.0	25.0	0.0	0.0
Maids	5	80.0	20.0	0.0	0.0
Artisans and traders	8	87.5	12.5	0.0	0.0
Housewives	18	94.4	5.6	0.0	0.0
Agriculture	4	100.0	0.0	0.0	0.0
Total	57	82.5	14.0	1.8	1.8

DISCUSSION

Data on the prevalence of hyaline pleural plaques, in the general population or in specific occupational groups, are available for various regions.^{1,2,6-8,11-13,15} Several studies are based on chest X-ray findings, and others on necropsy material. Since the sensitivity of X-ray examination in detected pleural plaques is low,¹² the comparisons between the two types of investigation are of limited value.

The prevalence we observed in the present series appears to be very high when compared to those found in other necropsy series.¹ The residents in the Monfalcone area seem to be particularly involved.

The marked difference in the prevalence of pleural plaques between the two sexes is a first indication that an occupational source might represent the most important cause of the plaques in our cases. This idea is strongly corroborated by occupational histories.

Some researchers¹² believe that at retirement probably nearly all the shipyard workers have pleural plaques. The present findings confirm such an opinion. In our material over 90% of the subjects, who had worked only in the shipyard, showed hyaline pleural plaques. Moreover other industries have been identified as causes of plaques. In particular, working in a sodium carbonate factory, a plant active in Monfalcone until 20 years ago, was almost constantly associated with the presence of plaques.

In clarifying the etiology of pleural plaques in the Monfalcone series, occupational data as well as the findings concerning lung asbestos content have to be considered.

A history of employment in the shipyard represents a strong indication of asbestos exposure so that pleural plaques, we found in shipyard workers, may be attributed to asbestos. As far as the majority of the other workplaces appearing in the occupational histories were concerned, we were able to ascertain that they implied an asbestos exposure. However, the meaning of some data remains uncertain. For instance pleural plaques (mostly small) have been observed in some subjects with histories of employment in agriculture. We could not ascertain the etiology of the plaques in these cases; an environmental exposure to asbestos is a possible cause, but incompleteness of the history data or the role of factors other than asbestos cannot be excluded.

Information furnished by quantitation of lung asbestos bodies supports the idea that asbestos is by far the most important cause of pleural plaques in the present series. In fact a good correlation was observed between the amount of asbestos bodies and pleural plaques. Nevertheless in several cases with histories indicative of important occupational asbestos exposure and with large pleural plaques, low numbers of asbestos bodies were found. Conversely some heavily exposed subjects showed large amounts of asbestos bodies, not associated with the presence of pleural plaques.

The low number of asbestos bodies in exposed subject may be explained by different factors, such as the clearance of asbestos fibers,¹⁴ or individual differences in the production of asbestos bodies.⁹ Moreover it should be remembered that

the sensitivity of the Smith-Naylor method, the techniques used in the present investigation, has recently been questioned.¹⁰ Concerning the absence of pleural plaques in heavily exposed persons, in our material this situation was usually associated with the presence of firm, diffuse adhesions between the visceral and parietal pleura.

CONCLUSIONS

In the Monfalcone area a consistent portion of the male population has spent some part of their life in the shipyard. Consequently it is not surprising that a very high prevalence of hyaline pleural plaques has been observed in this territory. However, the present investigation furnishes data on the intensity of asbestos exposure in the Monfalcone shipyard. Moreover other sources of asbestos exposure, before unsuspected, have been identified and the magnitude of the phenomenon "domestic asbestos exposure" in this territory has been defined. In our experience detection of pleural plaques represents a valid way of monitoring asbestos exposure.

REFERENCES

1. Andron, A., Colombo, A., Dacorsi, M., Mollo, F.: Pleural Plaques at Autopsy in Turin. A Study on 1,019 Adult Subjects. *Eur. J. Respir. Dis.* 63:107-112 (1982).
2. Baris, Y.I.: *Asbestos and Erionite Related Chest Diseases*. pp 111-169 Semih Ofset Matbaacilik Ltd. Co., Ankara (1987).
3. Bianchi, C., Broilo, A., Miniussi, C., Bittesini, L.: Asbestos Exposure in the Monfalcone Area. A Social and Pathological Study of 100 Autopsy Cases. *Tumori* 67:279-282 (1981).
4. Bianchi, C., Broilo, A., Bittesini, L.: Asbestos Exposure in the Monfalcone Shipyard Area (Italy). A Study Based on a Necropsy Series. *Xth World Congress of Occupational Accidents and Diseases*, pp 81-85, Ottawa-Hull, Canada (1983).
5. Bianchi, C., Broilo, A., Bittesini, L., Ramani, L.: Asbestos Exposure in the Monfalcone Shipyard Area (Italy). *Risk Assessment of Occupational Exposures in the Harbour Environment*, pp 128-135, Genoa, Italy (1984).
6. Bianchi, C., Broilo, A., Bittesini, L., Ramani, L.: Esposizione all'asbesto nel territorio di Monfalcone. *Riv. Inf. Mal. Prof.* 73:275-282 (1986).
7. Bianchi, C., Broilo, A., Bittesini, L., Ramani, L.: Placche ialine della pleura ed esposizione domestica all'asbesto. *Med. Lav.* 78:44-49 (1987).
8. Constantopoulos, S.H., Langer, A.M., Saratzis, N., Nolan, R.P.: Regional Findings in Metsovo Lung. *Lancet* 2:452-453 (1987).
9. Dodson, R.F., Williams, M.G., Jr., O'Sullivan, M.F., Corn, C.J., Greenberg, S.D., Hurst, G.A.: A Comparison of the Ferruginous Body and Uncoated Fiber Content in the Lungs of Former Asbestos Workers. *Am. Rev. Respir. Dis.* 132:143-147 (1985).
10. Ehrlich, A., Suzuki, Y.: A Rapid and Simple Method of Extracting Asbestos Bodies from Lung Tissue by Cytocentrifugation. *Am. J. Ind. Med.* 11:109-116 (1987).
11. Hillerdal, G.: *Pleural Plaques, Occurrence, Exposure to Asbestos, and Clinical Importance*, pp 35-49. Acta Universitatis Upsaliensis, 363, Uppsala (1980).
12. Jarvholm, B., Arvidson, H., Bake, B., Hillerdal, G., Westrin, C.G.: Pleural Plaques-Asbestos-III-Health. *Eur. J. Respir. Dis.* 68, Suppl. 145, 1-59 (1986).
13. Kilburn, K.H., Warshaw, R., Thornton, J.C.: Asbestos Diseases and Pulmonary Symptoms and Signs in Shipyard Workers and Their Families in Los Angeles. *Arch. Intern. Med.* 146:2213-2220 (1986).
14. Lippmann, M.: Asbestos Exposure Indices. *Environ. Res.* 46:86-106 (1988).
15. Rogan, W.J., Gladen, B.C., Ragan, N.B., Anderson, H.A.: US Prevalence of Occupational Pleural Thickening. A Look at Chest X-Rays from the First National Health and Nutrition Examination Survey. *Am. J. Epidemiol.* 126:893-900 (1987).
16. Smith, M.J., Naylor, B.: A Method for Extracting Ferruginous Bodies from Sputum and Pulmonary Tissue. *Am. J. Clin. Pathol.* 58:250-254 (1972).

MORPHOLOGY, CHARACTER AND FEATURES OF ANTOPHYLLITE-INDUCED MESOTHELIOMAS

K. KOLEV

Institute of Hygiene and Occupational Health, Medical Academy, Sofia, Bulgaria

ABSTRACT

A histological, cytological, histochemical and electron-microscopic observation was carried out on 109 mesotheliomas, induced by /UICC/, Bulgarian and Soviet antophyllites. Intraperitoneal and intrapleural method of application were used. Most characteristic of the antophyllite-induced mesotheliomas is the fact that in 55 to 72% in terms of their infrastructure they conform to the sarcomatous variant. This feature is in complete contradiction with science in the experimental and human mesotheliomas caused by crocidolite, amosite and chrysotile, where the prevailing variant is the carcinomatous one—about 60% while the sarcomatous account for about 10-15%. The prevailing position of the sarcomatous variant in the first case is not influenced by the kind of antophyllite, the morphology of the dust applied, nor by the way of application.

The author proposes a new histogenetic classification of antophyllite-induced mesotheliomas.

No Paper provided.

CELL TYPES OF ASBESTOS LUNG CANCER

COLEMAN B. RABIN, M.D. • Irving J. Selikoff, M.D. • Yasunosuke Suzuki, M.D. • Ruth Lilis, M.D.

Div. of Environmental & Occupational Medicine, Mt. Sinai School of Medicine of the City University of New York, USA

ABSTRACT

We have been following a cohort of asbestos insulation workers from January 1, 1967. By January 1, 1985, there were 526 lung cancer deaths in which we had opportunity to review initial diagnostic X-rays, histological material, and clinical findings. We will present the distribution of cell types, including small cell carcinoma, squamous cell, adenocarcinoma, large cell carcinoma, bronchoalveolar carcinoma, and less common cell types, in relation to topographical findings and other parameters.

No Paper provided.

RELEASE OF A "FIBROBLAST PROLIFERATION FACTOR" FROM HUMAN MACROPHAGES IN VITRO TREATED WITH QUARTZ DUST DQ 12 OR COAL MINE DUSTS

N.H. SEEMAYER • E. Maly

Medical Institute of Environmental Hygiene at the University Gurlittstr. 53, D-4000 Dusseldorf, F.R.G.

INTRODUCTION

Alveolar macrophages are the primary target for the noxious effect of quartz—and coal mine dusts in human and animal lung. Macrophages produce a very large number of more than 50 "biofactors" or "mediators" which participate in various inflammation and immunological regulation processes.^{16,26} Heppleston and Styles⁹ reported in 1967 that after incubation with quartz dust, peritoneal macrophages of the rat produce a factor which stimulates chicken fibroblasts to collagen synthesis. After initially negative reports⁸ Heppleston's findings have been confirmed by various investigators using diverse *in vivo* and *in vitro* cell systems.^{1,5,11,12,27} Recently, evidence is accumulating about the formation of mediators in human monocyte and macrophage cultures following stimulation with soluble and particulate agents which stimulate fibroblasts to cell replication.^{3,6,7,13,19} Various reports suggest, that human monocytes and macrophages have the ability to generate multiple "fibroblast activating factors," depending on culture conditions, agents used for stimulation, cell type and assay employed for activity evaluation.^{3,6,7,13,19,26} As an extension of our report of 1986,²³ this paper presents results on the formation of a "Fibroblast proliferation factor" in human monocyte/macrophage cultures following incubation with quartz dust DQ 12 and coal mine dusts TF-1 from the Ruhr-area (FRG).

MATERIALS AND METHODS

Cell Cultures

Isolation of human monocytes from peripheral blood in Ficoll-Hypaque gradient and cultivation of monocytes to maturation of cells with characteristics of macrophages has already been described in detail elsewhere.²² The cell line FH-3 (human embryonal skin fibroblasts) and the cell line (FH-27) (human embryonal lung fibroblasts) were obtained from Biochrom, Berlin (FRG). The cell line WI-38 (human embryonal lung fibroblasts) were purchased from Flow Laboratories, Meckenheim, FRG and the cell line MRHF (human foreskin dermal fibroblasts) from Api-BioMerieux Nürtingen, FRG. The cell lines of human lung and dermal fibroblasts were cultured in Dulbecco's modified Minimum essential medium with 10% foetal calf serum and antibiotics (Pencillin 100 I.U./ml, Streptomycin 100 µg/ml).

Mine Dust and Control Dust

The TF-1 dust, fraction BAT-II from the Ruhr region was kindly supplied by the Hauptstelle for Staubbekämpfung und

Pneumokonioseverhütung des Steinkohlenbergbauvereins in Essen. This is a mine dust with a high mineral content of 95 wt % and a quartz content of 10.6 wt %, with a particle size distribution of 0.5–2.5 µm.²⁰

Quartz dust DQ 12 was used as the toxic dust (positive control). This is Dorentruper crystall quartz flour (grinding no. 12) with a particle size 5 µm.

Preparation of Supernatants from Cultures of Human Monocytes/Macrophages

Dust samples were suspended in Iscove medium or RPMI-1640 medium without an addition or with 1% newborn calf serum. The samples were subjected to ultrasonic treatment (Sonifier B-12 from Branson Sonic Power Company, USA) in order to achieve a uniform distribution of the particles and to destroy germs. Suspended dust samples in concentrations as described under "Results" were added to cultures of human monocytes/macrophages. After an incubation period of 24 hours at 37°C, the culture supernatants were centrifuged for 15 min at 3,000 rpm and then filtered through Millipore filters (pore size 0.45 µm). The supernatants were then deep frozen at -20°C until used.

Chemicals and Equipment

Fibroblast growth factor (FGF) was purchased from Sigma, Munich (FRG) and Boehringer, Mannheim (FRG), Platelet derived growth factor (PDGF), porcine, Speywood Laboratories was obtained from Sebak Company, Aidenbach, FRG. Ultrafree PF Filter Units of 10.000 and 30.000 NMWL and Centrifugal Ultrafree Filter Units of 10.000 and 30.000 NMWL were commercially available from Millipore, Eschborn, FRG.

Determination of Cell Growth of Human Dermal and Lung Fibroblasts

Human fibroblast cell lines (FH-3, MRHF, FH-27, WI-38) were detached with a trypsin-Versene mixture and adjusted to a cell count of 4–6 × 10⁴ cells/ml in Dulbecco's MEM with 1% foetal calf serum or with 10% serum (2% foetal and 8% newborn calf serum), corresponding to dermal and lung fibroblasts, respectively. 1 ml of this cell suspension per well was transferred to a tissue culture plate with 24 wells (Falcon 3047 MultiWell tissue culture plate) or to LAB-Tissue Culture Chamber (4 chamber, LT-4804). 24 hours later cell cultures were re-fed with Dulbecco's MEM with 0.5% foetal calf

serum or with 0.15% bovine serum albumin (Boehringer Mannheim, FRG) and kept for 2–4 days to obtain “quiescent” cultures. The macrophage supernatants were added in an amount of 0.2 ml per well or chamber. In each case 4 cultures were used per measurement point. The protein determination according to Lowry in the modification of Oyama and Eagle¹⁸ was carried out as already described earlier.²¹ A protein calibration curve was plotted with “pure” bovine serum albumin from Serva, Heidelberg (FRG). For morphological evaluation of cell cultures by light microscopy we used a standard procedure of fixation and staining with Bouin’s solution and hematoxylin-eosin or with methanol and Giemsa.

Statistical Analysis

For statistical analysis data were computerized and mean values and limits of confidence were determined. Furthermore, Bartlett test for equal variances, one-way analysis of variance and Student’s t-test were performed.

RESULTS

Human fibroblast cultures, “quiescent” or showing only slight cell replication were used to quantify the “fibroblast proliferation activity” of supernatants from treated and untreated human macrophage cultures. The results of such an experimental set-up are shown on Figure 1. Human macrophages were cultivated for 7 days. Thereafter cells were treated with quartz dust DQ 12 for 24 hours in Iscove medium without serum at a concentration of 30 $\mu\text{g}/\text{ml}$ per approximately 1×10^6 cells. Supernatants were collected as outlined in Materials and Methods. To cell cultures of human dermal fibroblasts (FH-3) supernatants of untreated and quartz dust DQ 12 treated macrophages were added. After a culture period of 6–8 days on an average, the protein content of the cultures was determined by the method of Lowry in the modification of Oyama and Eagle.¹⁸ Column 1 (Figure 1) shows an untreated FH-3 fibroblast culture. The amount of

protein in $\mu\text{g}/\text{ml}$ is given as a criterion of cell growth. Column 2 illustrates the cell growth of the fibroblast culture to which the supernatants of the untreated macrophage culture had been added. No increase in cell growth is seen in comparison with the control. Column 3–6 (Figure 1) represent the growth of human dermal fibroblast culture FH-3 to which the supernatant of a macrophage culture treated with 30 $\mu\text{g}/\text{ml}$ DQ 12 had been added in various dilutions. The potent “proliferation-stimulating activity” of this supernatant led nearly to doubling of the protein content of these cultures at a dilution of 1:5 in the course of 7 days in comparison with the control (Column 3). But also at higher dilutions of 1:10 up to 1:40 the “proliferation-stimulating activity” of this supernatant can be seen (Column 4–6).

The “proliferation-stimulating activity” of supernatants of human macrophages (age 7 days) to which the coal mine dust TF-1, fraction BAT-II had been added for 24 hours was tested in further experiments. For this purpose, supernatants of untreated human macrophage cultures and of those treated with coal mine dust TF-1 (30 $\mu\text{g}/\text{ml}$, 24 hours) were added to human fibroblast cultures (line FH-3) and cultured at 37°C for 7 days. The results are shown on Figure 2. Column 1 represents the cell control, column 2 shows the cell growth of the fibroblasts after addition of the supernatant of untreated macrophages. Column 3–6 (Figure 2) represent the cell growth following addition of supernatant of macrophages treated with coal mine dust TF-1. In comparison with the cell and macrophage control, there is a significant increase in cell growth of the human dermal fibroblasts FH-3 which had been incubated with the supernatant of macrophages treated with coal mine dust TF-1. A similar “proliferation-stimulating effect” was observed with human diploid lung fibroblasts WI-38 treated with supernatants from another batch of human macrophages incubated with coal mine dust TF-1 (30 $\mu\text{g}/\text{ml}$, 24 hours). We made further attempts to characterize the factor produced by quartz and coal mine dust exposed human macrophages. We found that the factor is still active after

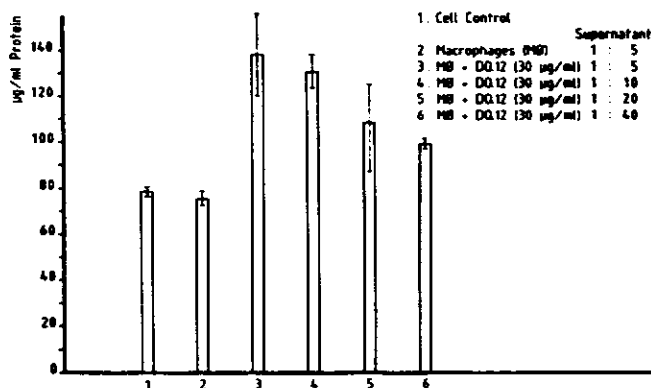

Figure 1. Cell growth of human fibroblasts of cell line FH-3 following incubation with the supernatant of an untreated (column 2) human macrophage culture and one incubated with quartz dust DQ 12 (column 3–6) in various dilutions. Mean values and confidence limits are shown.

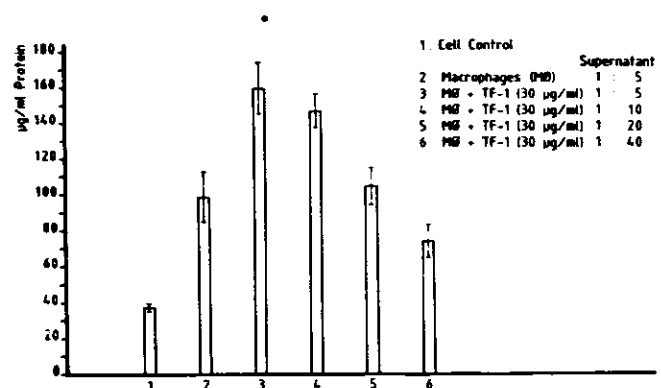

Figure 2. Cell growth of human fibroblasts of cell line FH-3 following incubation with the supernatant of an untreated (column 2) and one treated with coal mine dust TF-1, BAT-II (column 3–6) in various dilutions. Mean values and limits of confidence are presented.

incubating at 56°C for 60 min. For estimation of the approximate molecular weight of the factor we utilized Ultrafree PF Filter Units (Millipore) of 10,000 and 30,000 NMWL (nominal molecular weight limits) and corresponding Centrifugal Ultrafree Filter Units (Millipore) of 10,000 and 30,000 NMWL. Results based on induced cell multiplication of non-replicating MRHF and FH-3 fibroblasts and on stimulation of DNA synthesis of WI-38 cells by the supernatant of quartz dust DQ 12 exposed human macrophages larger and smaller than 10,000 and 30,000 NMWL indicate a molecular weight of the factor of more than 30 kDa. In further experiments we incubated non-replicating WI-38 cells for various lengths of time (2, 4, 16 and 24 h, 7 days) with supernatants of quartz dust DQ 12 exposed macrophages. Results revealed that a continuous presence of the factor is necessary for cell replication. This assumption is also supported by measuring the number of DNA synthesizing cells of WI-38 cells exposed for various lengths of time to supernatant. Only continuous presence of the factor led to a high number of DNA synthesizing cells.¹⁰ After removal of the factor the DNA synthesis ceased very rapidly. To elucidate the nature of the "fibroblast proliferation factor" we performed "complementation tests" according to Stiles et al.²⁵ and Bitterman et al.³ Addition of fibroblast growth factor or of platelet derived growth factor (PDGF) to non replicating WI-38 or MRHF-cells enhanced the cell growth significantly in presence of supernatants of quartz dust DQ 12-treated human macrophages. Similar results were obtained with WI-38 cells in presence of supernatant of coal mine dust TF-1 treated human macrophages. Addition of FGF or PDGF led to a remarkable enhancement of cell multiplication.

DISCUSSION AND CONCLUSION

Results presented demonstrate that human macrophages in culture obtained by cultivation and differentiation of blood monocytes, form a soluble factor(s) following incubation with quartz dust DQ 12 or coal mine dust TF-1. This factor stimulates "quiescent" or only moderately replicating human lung and dermal fibroblasts to a considerable cell multiplication. Therefore, we designated the "factor" as "fibroblast proliferation factor" (FPF).

As we earlier reported,^{23,24} the process of fibroblast multiplication stimulated by FPF could also be visualized by morphological criteria, such as increased rate of DNA synthesis¹⁰ and of mitosis and by manifestation of high cell density of cultures.

The "dual control model of growth regulation" suggests²⁵ that growth factors can be classified either as "competence factors" or as "progression factors." While cells require only transient exposure to "competence factors," i.e. PDGF, FGF, "progression factors" are required continuously for DNA synthesis and cell replication. Results suggest a classification of FPF as a "progression factor" because a continuous exposure was required for cell multiplication of fibroblasts and in view of an enhanced growth after addition of FGF or PDGF in a serum-free medium "complementation test."

Bitterman et al.³ reported that human alveolar macrophages obtained by lung lavage and incubated in vitro with soluble

and particulate agents, release an alveolar macrophage derived growth factor (AMDGF), exhibiting activity as a "progression factor" for human lung fibroblasts. The molecular weight of AMDGF of 18 kDa differs from the MW of FPF, preliminary estimated as more than 30 kDa. Thermal stability of FPF (56°C, 60 min) is resembling stability of an alveolar macrophage factor from silica instilled rats, isolated by Benson et al.,² inducing elevated DNA synthesis of rat lung fibroblasts. Beside FPF in supernatants of quartz DQ 12 or coal mine dust TF-1 treated human monocytes/macrophages a "Granulocyte activating Mediator" (GRAM) was detected^{14,15} causing a long lasting Lucigenin-dependent chemiluminescence of human granulocytes.

In several studies "fibroblast growth factors" have been described, which were induced in cultures of human monocytes and macrophages by various soluble and particulate agents, i.e. by zymosan, phytohemagglutinine, concanavalin A, endotoxin, immune complexes, staphylococci and quartz dust (Bitterman et al.,³ Dohlman et al.,⁶ Glenn and Ross,⁷ Leslie et al.,¹³ Schmidt et al.,¹⁹ Seemayer et al.^{23,24}

The growth stimulation of fibroblasts by activated or damaged macrophages is of great importance for fibrotic lung processes especially silicosis and appears to be a generally applicable, pathobiological principle.⁴

REFERENCES

1. Aalto, M., Kulonen, E., Rönnemaa, T., Sundstrom, C., Vilpo, J.: Liberation of a fibrogenic factor from human blood monocytes, ascites cells, cultures histocytes and transformed mouse macrophages by treatment with SO₂. *Scand. J. Clin. Lab. Invest.* 40:311-318 (1980).
2. Benson, S.C., Belton, J.S., Scheve, L.G.: Regulation of lung fibroblast proliferation and protein synthesis by bronchoalveolar lavage in experimental silicosis. *Environ. Res.* 41:61-78 (1986).
3. Bitterman, P.B., Rennard, S.I., Hunninghake, G.W.: Human alveolar macrophage growth factor for fibroblasts. *J. Clin. Invest.* 70:806-822 (1982).
4. Bowden, D.H.: The alveolar macrophage. *Environ. Health Persp.* 55:327-341 (1984).
5. Burrell, R., Anderson, M.: The induction of fibrogenesis by silica-treated alveolar macrophages. *Environ. Res.* 6:389-391 (1973).
6. Dohlman, J.G., Payan, D.G., Goetzl, E.J.: Generation of a unique fibroblast-activating factor by human monocytes. *Immunology* 52:577-584 (1984).
7. Glenn, K.C., Ross, R.: Human monocyte-derived growth factor(s) for mesenchymal cells: Activation of secretion by endotoxin and concanavalin A. *Cell* 25:603-615 (1981).
8. Harrington, J.S., Ritchie, M., King, P.C., Miller, K.: The in vitro effects of silica treated hamster macrophages on collagen production by hamster fibroblasts. *J. Pathol.* 109:21-37 (1973).
9. Heppleston, A.G., Styles, J.A.: Activity of macrophage factor in collagen formation by silica. *Nature* 214:521-522 (1967).
10. Hubner, K., Seemayer, N.H.: Stimulation of DNA synthesis of human diploid lung fibroblasts by mediators from quartz and coal mine dust treated human macrophages (*in preparation*).
11. Kilroe-Smith, T.A., Webster, I., van Drummelen, M., Marases, L.: An insoluble fibrogenic factor in macrophages from guinea pigs exposed to silica. *Environ. Res.* 6:290-305 (1973).
12. Kulonen, E., Aalto, M., Aho, S., Lehtinen, P., Potila, M.: The SiO₂-liberated fibrogenic macrophage factors with reference to RNA. In: *The In Vitro Effects of Mineral Dusts*. Ed. by R.C. Brown, M. Chamberlain, R.Davies and I.P.Gormley. London: Academic Press 1980, pp. 282-287.
13. Leslie, C.C., Musson, R.A., Henson, P.M.: Production of growth factor activity for fibroblasts by human monocyte-derived macrophages. *J. Leukocyte Biol.* 36:143-159 (1984).

14. Maly, E., Braumann, A., Seemayer, N.H., Maly, F.E.: Induction of chemiluminescence of human granulocytes by supernatants of human mononuclear cultures after treatment with quartz dust DQ 12. in: *Biochemiluminescence and Chemiluminescence*, New Perspectives ed. by Schölmerich R. et al. J. Wiley & Sons, Chichester-New York 1987, pp 121-124.
15. Maly, E., Seemayer, N.H., Braumann, A., Behrendt, H., Manojlovic, N., Maly, F.E.: The significance of immunomodulative cytokines for the development of silicosis. I. Biological characterisation of a granulocyte activating mediator from human monocytes/macrophages treated with quartz dust DQ 12. *Nordrhein-Westfalen Silicosis Report* Vol. 16:157-170 (1987).
16. Nathan, C.F. et al.: The macrophage as an effector cell. *New England J. Med.* 303:622-626 (1980).
17. Nourse, L.D., Nourse, P.N., Botes, H., Schwartz, H.M.: The effects of macrophages isolated from lungs of guinea pigs dusted with silica on collagen biosynthesis by guinea pig fibroblasts in cell culture. *Environ. Res.* 9:115-127 (1975).
18. Oyama, V.J., Eagle, H.: Measurement of cell growth in tissue culture with a phenol reagent (folin-ciocalteu). *Proc. Soc. Exp. Biol.* 91:305-307 (1956).
19. Schmidt, J.A., Oliver, C.N., Lepe-Zuniga, J.L., Green, I., Gery, I.: Silica-stimulated monocytes release fibroblast proliferation factors identical to interleukin 1. A potential role for interleukin 1 in the pathogenesis of silicosis. *J. Clin. Invest.* 73:1462-1472 (1984).
20. Seemayer, N.H.: Importance of grain size and mineral content of coal mine dusts for cytotoxicity on macrophages *in vitro*. In: *In Vitro Effects of Mineral Dusts* Ed. by E.G. Beck and J. Bignon Springer-Verlag Berlin Heidelberg 1985, p. 497-504.
21. Seemayer, N.H., Manojlovic, N.: Cytotoxic effects of air pollutants on mammalian cells *in vitro*. *Toxicology* 17:177-182 (1980).
22. Seemayer, N.H., Braumann, A.: Untersuchung über die zytotoxische Wirkung von Quarz- und Grubenstäuben auf menschliche Makrophagen *in vitro*. In: *Ergeb. Unters. Geb. Staub- u. Silikosebekämpfung im Steinkohlenbergbau. Nordrhein-Westfalen Silicosis Report*, Vol 15, Essen: Steinkohlenbergbauverein 1985, p. 301-320.
23. Seemayer, N.H., Braumann, A., Maly, E., Behrendt, H., Maly, F.: Induction of fibroblast proliferation by supernatants from human monocytes/macrophages *in vitro* treated with quartz dust DQ 12 and coal mine dust TF-1. *Zbl. Bakt. Hyg. B* 184:431 (1987).
24. Seemayer, N.H., Braumann, A., Maly, E.: Development of an "in vitro" test system with human macrophages and fibroblasts for analysis of the effect of quartz dusts and coal mine dusts. I. Formation of a fibroblast proliferation factor. *Nordrhein-Westfalen Silicosis Report* Vol. 16:143-156 (1987).
25. Stiles, C.D. et al.: Dual growth control of cell growth by somatomedins and platelet-derived growth factor *Proc. Nat. Acad. Sci.* 76:1279-1283 (1979).
26. Wahl, S.M.: The role of lymphokines and monokines in fibrosis. *Ann. N.Y. Acad. Sci.* 460:224-231 (1985).

¹New address: Department of Anatomy, The University of Arizona, Tucson, AZ 85724.

USE OF A SENSITIVE ELECTRO-OPTICAL METHOD TO QUANTIFY SUPEROXIDE PRODUCTION FROM SINGLE PULMONARY ALVEOLAR MACROPHAGES EXPOSED TO DUSTS *IN VITRO* OR *IN VIVO*: SOME CURRENT EXPERIMENTAL AND MODEL RESULTS

EUGENE V. CILENTO, Ph.D. • K. A. DiGregorio, Ph.D. • R. Clark Lantz, Ph.D.¹

Departments of Chemical Engineering and Anatomy, 413 Engineering Sciences, West Virginia University, Morgantown, WV 26506-6101, USA

ABSTRACT

This laboratory has developed a sensitive electro-optical method to quantify the initial rate (R) and total amount (MAX) of superoxide (O_2^-) produced by single pulmonary alveolar macrophages (PAM). The method uses a microscope-based TV system to visualize PAM in culture, and to video record the images during the time the cells produce O_2^- . MAX and R are calculated from measurement of temporal changes in optical density in the images due to precipitated diformazan formed by the reaction of O_2^- , produced by each PAM, with nitroblue tetrazolium present in the culture medium. To date, values of R and MAX, measured due to adherence of PAM to the dish, have been compared to values obtained when quartz, coal mine dust (CMD), and kaolin were added to the medium (*in vitro*). R and MAX have also been calculated for PAM lavaged from animals exposed to quartz and CMD in the WVU Inhalation Facility. Presently, experiments are being done using serum which will permit PAM to be restimulated by different dusts to help establish a dose response relationship and a means to study the role of lung surfactant on modifying the acute toxicity of inhaled dusts. Ultimately, this methodology should provide useful insight into establishing the role of O_2^- in PAM dysfunction due to inhalation of dusts, and in lung diseases such as pneumoconioses.

INTRODUCTION

PAM are free cells found in the lungs which protect the lungs by removing foreign debris and bacteria. This is accomplished, in part, by the process of phagocytosis, whereby foreign matter is internalized into vesicles known as primary phagosomes. Phagocytosis also involves the chemical breakdown of inhaled dusts and the killing of microbes. Detoxification is aided by the respiratory burst, which is a metabolic response of the cell to foreign substances, that results in the production of highly reactive oxidizing agents from the partial reduction of extracellular oxygen to superoxide (O_2^-) at the surface of the plasma membrane. Superoxide undergoes either spontaneous or enzyme catalyzed dismutation reactions to form hydrogen peroxide (H_2O_2) and subsequently hydroxyl radical (OH^\bullet) and singlet oxygen (O_2^1). However, while these oxygen metabolites aid in the killing of microbes they also may destroy endogenous tissue. For example, O_2^- has been linked to the aging process and to many diseases including emphysema, diabetes, and cancer.⁴ Therefore, a better understanding of the production of O_2^- is extremely important since an abnormally low production could result in damage by inhaled dusts and bacteria while an abnormally high production could result in direct damage to the lung tissue by the phagocytes.

Inhalation of respirable sized mineral dusts, such as quartz (silica), coal mine dusts (CMD), and asbestos, results in various pulmonary disorders. PAM are thought to play an important role since evidence suggests that the first step in

fibrogenesis is an interaction of dust particles with PAM. Generally, *in vivo* exposure of animals to mineral dusts results in increased respiratory burst activity, migratory patterns, phagocytic behavior, and secretory potential of PAM, and for this reason these have been implicated to be pivotal events in the pathogenesis of pulmonary diseases.¹ In addition to stimulation of resident PAM, an influx of monocytes into the lung and/or production of new macrophages generally occurs in response to fibrogenic dust inhalation. Further, PAM may attract and stimulate fibroblasts, which normally synthesize proteins and collagen during repair of tissue, by secreting chemoattractants and enzymes. Thus, PAM may be involved in pulmonary disorders through failure or partial loss of their defensive capability, or indirectly, through release of other mediators.

The major objective of this project is to develop a better understanding for the role O_2^- production by PAM plays in the development of pulmonary disease following exposure to inhaled dusts. Specifically, it is not understood whether certain dusts (or constituents of dusts), inhaled over a period of time, can alter the ability of this cell-type to remove foreign material from the lung. Also, it is not known whether dysfunction of PAM occurs which may result in an underproduction or an overproduction of O_2^- ; either of which may be harmful to normal lung tissue.

A novel technique has been developed to quantify O_2^- production by *single* PAM which has permitted study of the

effects of different dusts, concentrations of dust, and time of exposure on O_2^- release by PAM. A multifaceted approach has been used which encompasses the following: (1) study of O_2^- production by single PAM isolated in culture, when contacted directly with different concentrations of dusts suspended in the medium (*in vitro*); (2) study of O_2^- production by PAM after *in vivo* exposure to dusts in inhalation chambers for known periods of time; and (3) development of a mathematical model to describe the kinetics of production by single cells. These studies ultimately will provide a rapid, quantitative assay to determine the effect of toxic dusts on O_2^- production by PAM.

METHODOLOGY

The methodology for measuring O_2^- production from single PAM using NBT reduction was developed previously.^{2,3} Briefly, 3 ml of NBT solution (37 C) was placed in culture dishes and then 0.4 ml of a cell suspension ($2-5 \times 10^5$ PAM) added. A layer of paraffin oil was placed on top of the aqueous layer. The dish was placed on a temperature controlled stage of an inverted microscope and trans-illuminated at 550 nm. In the presence of a strong reducing agent, such as O_2^- produced due to PAM adherence to the culture dish, soluble NBT is reduced to a diformazan precipitate which can be measured spectrophotometrically. PAM were visualized (20x) and images, containing at least 6 well-separated PAM, were televised and video recorded for 40 min. Recorded images were played back through electronic instrumentation which permitted determination of optical density (OD) changes for individual cells due to precipitated diformazan. The OD was converted to the mass of diformazan produced versus time, from which MAX was determined directly, and then the data fit to a phenomenological equation from which R was calculated.

RESULTS

In Vitro Experiments

The effects of acute *in vitro* exposure to respirable quartz and kaolin on O_2^- production during adherence of PAM to culture dishes were tested using low (0.025 mg/ml) and high (0.05 mg/ml) dust concentrations. The low dose of quartz decreased the maximum amount of O_2^- produced (MAX) 38% compared to control while the high dose did not. However, the maximum rate of diformazan production, R, decreased 31% and 24% for the low and high dose, respectively. *In vitro* exposure of PAM to the high dose of sonicated CMD suspensions resulted in increased O_2^- production. In contrast, kaolin, a non-fibrogenic dust did not significantly change either MAX or R. These results suggested that O_2^- production may be a better indicator of pathogenicity and PAM dysfunction than cell death, which gives comparable results for quartz and kaolin. Interestingly, no changes in O_2^- production were observed following *in vitro* exposure of PAM to quartz, kaolin, or CMD in the presence of a surfactant (tween 80), suggesting that lung surfactant may alter the acute toxicity of dusts.

Previously, PAM could not be restimulated after adherence. However, it has been recently shown that O_2^- production from

adherent PAM is possible when cells are incubated with serum.³ Serum alone did not stimulate adherent PAM indicating serum is necessary but not sufficient for stimulation. This finding supports the idea that *in vivo* serum may condition PAM to produce O_2^- .

In Vivo Experiments

The effects of *in vivo* exposure of animals to respirable quartz (20 mg/m³, 16 hr/d, 5 d/wk of MIN-U-SIL 10, 95% <5 μ m) was tested by housing animals (2-4 weeks) in the WVU inhalation facilities. Control (no quartz) animals also were kept in identical inhalation chambers for 2-4 weeks. Following exposure, animals were removed from the inhalation chambers and housed in animal-care facilities for 3, 10, or 31 days post-exposure. This approach permitted analysis of the effects of length of *in vivo* exposure and post-exposure time on PAM analyzed for O_2^- production. Overall, respirable quartz increased MAX 36% and R 29% compared to control animals. Importantly, PAM from exposed animals showed an increased O_2^- production for up to 10 days after 2-4 weeks of exposure followed by a return to control levels by 31 days. Interestingly, the 3 day group suggested that there was activation and/or recruitment of PAM. *In vivo* exposures performed using CMD (20 mg/m³, 16 hr/d, 7 d/wk of Pittsburgh BOM Dust 2020, 100% 4-6 μ m) also showed increased production at 10 days post-exposure, with large amounts of CMD phagocytosed by 31 days. Similarly, the data showed an activation and/or recruitment of PAM.

Theoretical Model Development

A kinetic model was developed to describe the production of O_2^- by single PAM. The kinetic model considered three reactions: (1) the production of extracellular O_2^- from the reduction of oxygen by NADPH oxidase using intracellular NADPH as the substrate, (2) the subsequent dismutation of O_2^- to form H_2O_2 , and (3) the reaction of O_2^- and NBT. NBT specificity of O_2^- was analyzed by comparing experimental results, in the presence and absence of superoxide dismutase (SOD) which catalyzes the dismutation of O_2^- to H_2O_2 . Measured PAM heterogeneity (without SOD) was accounted for in the model by varying the concentration of intracellular NADPH, its rate of depletion, and the concentration of NADPH oxidase. Model predictions compared well with experimental results except when SOD was present. Experiments showed only a 50-60% decrease in diformazan production using SOD. This discrepancy may be due to diffusional limitations which occur since SOD is a much larger molecule (34 kD) compared to NBT (818 D). In addition, the cell surface is both ruffled and negatively charged, which may introduce steric hindrances and/or electrostatic effects since SOD is also negatively charged.

CONCLUSIONS

In vitro assays on large numbers of cells in culture using hemolysis of red blood cells or release of enzymes from PAM following dust exposure have been used to analyze cytotoxicity. In such systems, kaolin has been found to have an activity comparable to quartz on a mass basis. However, *in vivo*,

quartz is highly fibrogenic resulting in silicosis while kaolin is not. Therefore, the assay results do not correlate with the *in vivo* effects of quartz and kaolin. However, in this study, *in vitro* exposure to kaolin did not significantly alter O_2^- production compared to control PAM. The results obtained correlate more closely with *in vivo* exposure effects and help support the usefulness of this quantitative superoxide assay in evaluating the effects of respirable dusts on PAM. This suggests O_2^- production may play an important role in silicosis and other respiratory diseases. In addition, results from experiments with surfactant support the concept that lung surfactant may alter the toxicity of dusts inhaled into the lung.

Interestingly, *in vivo* exposure to quartz resulted in increased O_2^- production rather than the decrease observed *in vitro*. While this difference may be due to a change in cellular function from the *in vivo* to the *in vitro* environment, it is also possible the *in vitro* response may be due to an initial (acute) response produced immediately after contacting the cells with dusts. In contrast, the *in vivo* responses may have resulted from the longer contact time since animals were exposed 2-4 weeks followed by a 3-31 day post-exposure period before O_2^- analysis. Thus, it may be that quartz causes an initial injury to PAM resulting in decreased O_2^- production followed by recruitment or activation of PAM having increased production capabilities. This is supported by the fact that PAM analyzed 3 days post-exposure exhibited a wider range in O_2^- production than the control or 10 and 31 day groups. Specifically, perhaps two populations of PAM are present: (1) cells injured by initial or long-term dust contact, resulting in decreased O_2^- production release; and (2) recruited or activated PAM with an increased O_2^- production.

In summary, a sensitive, quantitative assay to study *individual* PAM function related to O_2^- production has been developed which shows that respirable dusts do affect O_2^- release by PAM. The *in vitro* results provide a basis for quantifying the *acute* effects of dust-cell contact (or constituents of dusts) on

O_2^- release by PAM. Importantly, the addition of serum to the culture medium permits restimulation of the *same* cell by different dusts after adherence of the cell to the culture dish. The *in vivo* results provide a basis for critically examining the effects of long-term exposure to airborne dusts on O_2^- production by PAM, and continued refinement of the methodology will provide a means to assess and improve present understanding of the phagocytosis process in health and disease.

Based on the results and conclusions obtained to date, continuing work is focused on several specific objectives. Experimental work is designed to critically examine the effects of repeated exposure to different dusts (and concentrations) on the ability of the same cell to produce and release O_2^- . Concomitantly, the ability to maintain animals for long periods of time in the inhalation chambers will permit evaluation of the effects of chronic exposure to dusts. This approach has the potential to provide information not possible using population measurements and to critically assess and ultimately lead to improved clinical therapies for treatment of pulmonary disorders.

REFERENCES

1. Brain, J. D. Macrophage Damage in Relation to the Pathogenesis of Lung Diseases. *Environ. Health Perspect.* 35:21-28, (1980).
2. DiGregorio, K. A., Cilento, E. V., and Lantz, R. C.: Measurement of Superoxide Release from Single Pulmonary Alveolar Macrophages. *Am. J. Physiol.* 252:C677-83 (1987).
3. DiGregorio, K.A.: *Studies of Superoxide Production from Single Pulmonary Alveolar Macrophages*. West Virginia University, Ph.D. dissertation. Morgantown, WV (1988).
4. Halliwell, B. Oxygen is Poisonous: The Nature and Medical Importance of Oxygen radicals. *Med. Lab. Sci.* 41:157-171 (1984).

ACKNOWLEDGEMENTS: The authors wish to acknowledge the support of the Department of the Interior's Mineral Institute Program administered by the Bureau of Mines through the Generic Mineral Technology Center for Respirable Dust (G1135142).

AN ATTEMPT FOR EVALUATION OF THE ALVEOLAR DUST DEPOSITION ON THE BASE OF THE PARTICLE SIZE DISTRIBUTIONS OF LUNG DUSTS

STOYNA IVANOVA-DJOURILOVA, M.Sc. • Petrana Tcherneva, M.Sc.

Institute of Hygiene and Occupational Health, Sofia, Bulgaria

INTRODUCTION

The experimental and theoretical studies of the way human lungs behave at different size distributions of the offered dusts and form the alveolar depot—the major determinant of the development of lung diseases, did not offer completely defined results. Regardless of the recent advances in this field, such as the derived curves of extrathoracic, tracheobronchial and alveolar deposition of inhaled particles and the lot of unified parameters, the criteria for respirable dust sampling and assessment of dust hazards etc.⁹ many problems did not find satisfactory answers.

The progress of technics and electronics eliminates the mass of difficulties in the particle size analysis and in the complicated calculations of the selective deposition of particles in the respiratory tract.

Presently, the most important problems derive from the impossibility to characterize precisely the entire dust inhaled by workers during their lifetime. The experimental studies in vivo on humans and animals, on models of the respiratory tract, as well as mathematical models providing a precise but valid information for the moment,⁶ are unable to assess yet the long-term retention of dust in the lungs as a response of the inhaled particles.

A very specious solution of these problems seems to be the study of dusts recovered post mortem from the lung tissue of dust-exposed workers and to compare them with the airborne dusts offered to the respiratory tract. Of course, a method of approach like this also has its disadvantages mainly in the assessment of the inhaled, resp. airborne dust. But it is possible after analyzing a significant number of airborne dust samples, collected in the work environment during a long period of time and including all technological processes used on the areas where employees had worked, to obtain a more or less rough approximation to reality. So, the respiratory tract with its special features and intersubject variability depending on individuals and experimental design, can be considered as a "black box" with known "inlet" and "outlet." Many authors have used lung dusts in their investigations and a lot of them support the reliability of the information received about the alveolar deposition of airborne particles.^{2,5,8}

Another important limitation of this experimental design can be the impossibility for assessment of particle aggregations and the kinetic behaviour of aggregates. Possible errors can be eliminated to some extent by analyzing fully dispersed samples of airborne and lung dusts using the same method for particle analysis.²

When the results from different studies of dust deposition in the respiratory tract are to be compared, it is particularly important to bear in mind that the main curves used nowadays as criteria for dust hazard evaluation⁹ are derived with monodispersed aerosols, while the determination of alveolar dust deposition with lung dust studies (representing a long-term retention of dust in lungs) is based on the inhalation of polydisperse aerosols.

Diu and Yu³ proposed a new mathematical model of polydisperse aerosol deposition in human respiratory tract, proving more or less considerable differences varying with the polydispersity. The model needs a validation on experimental studies. Investigation of lung dusts should be convenient for this purpose.

The mass particle size distributions of 47 samples of total airborne dust in the work environment of three mines—24 from a polymetal ore mine (PMM), 18 from copper mine A (CMA) and 5 from copper mine B (CMB) were determined. Full-shift sampling was performed at normal passing technological processes according to the actual standard in the country.¹ Samples were collected in different intervals of time during 10 years.

Fifty-nine dusts, recovered post mortem by the formamid method of Thomas and Stegemann¹² from the lungs of miners with entire length of service in the same mine, were analyzed for determination of the particle size distributions. Forty three of them were from the PMM group, 11—from CMA and 5—from CMB groups.

The particle size analyses were performed by two methods based on different principles: centrifugal sedimentation in Joyce-Loebl disc centrifuge⁴ analyzing particles in class intervals of Stokes diameters 0.01–20 μm and automatic counting of particles in liquid media with Coulter Counter (CC) using tube aperture 50 μm , analyzing particles in class intervals of UDS diameter 0.7–25 μm . Dust samples were suspended in filtrated 0.1% solution of sodium hexametaphosphate in distillate water. A lot of the analyses were performed with the same suspension. The Stokes particle size distributions were calculated in aerodynamic diameters using the density data for every dust. Particle size distributions were plotted on log-probability graph paper.

Mean values of the groups of airborne and lung dusts from the three mines were calculated, as well as the standard deviations and the confidence limits intervals. The standard deviations of the groups of airborne and lung dust from every mine

were compared statistically by means of the Fischer criterion.

The alveolar deposition was determined by the method described by Leiteritz, Einbrodt and Klosterkötter.⁵ The enrichment of fine sizes of each fraction of the lung dust particle size distribution was calculated as a ratio of the corresponding airborne dust fraction. This is the so-called enrichment factor. The relative alveolar deposition of each fraction is the quotient for the enrichment factors and the maximum enrichment factor which is taken to be = 1.

RESULTS AND DISCUSSION

Particle Size Distributions of Airborne and Lung Dusts

It was found that the mean values of the mass median aerodynamic diameters of the particle size distributions (MMAD) of the three groups of mine airborne dusts are in the class intervals 3–5 μm, analyzed by both methods. The mean geometric standard deviations (σg) of the groups were

varying from 4.4 to 5.3 for Joyce analysis and from 2.2 to 2.3 for Coulter Counter analysis. The airborne dust samples analyzed with Joyce were reduced to 5 combined samples for each mine, because the analysis needs about 50 mg of dust.

The mean value of MMAD of the particle size distributions of lung dusts of the three groups of miners was varying from 1.9 to 2.6 μm by both analyses and σg—from 3.3 to 3.6 and from 1.6 to 1.8 by Joyce and CC analyses, respectively.

The maximum frequency percentage of the particle size distributions, as well as the other data about them are presented in Table I.

Relative Alveolar Deposition

It was found that the maximum enrichment factors for the 3 groups of airborne and lung dusts are in the class interval 1.2–2.4 μm. The mean values for each size range of the enrichment factor were calculated and a curve of the relative alveolar deposition was derived (Figure 1). The theoretical

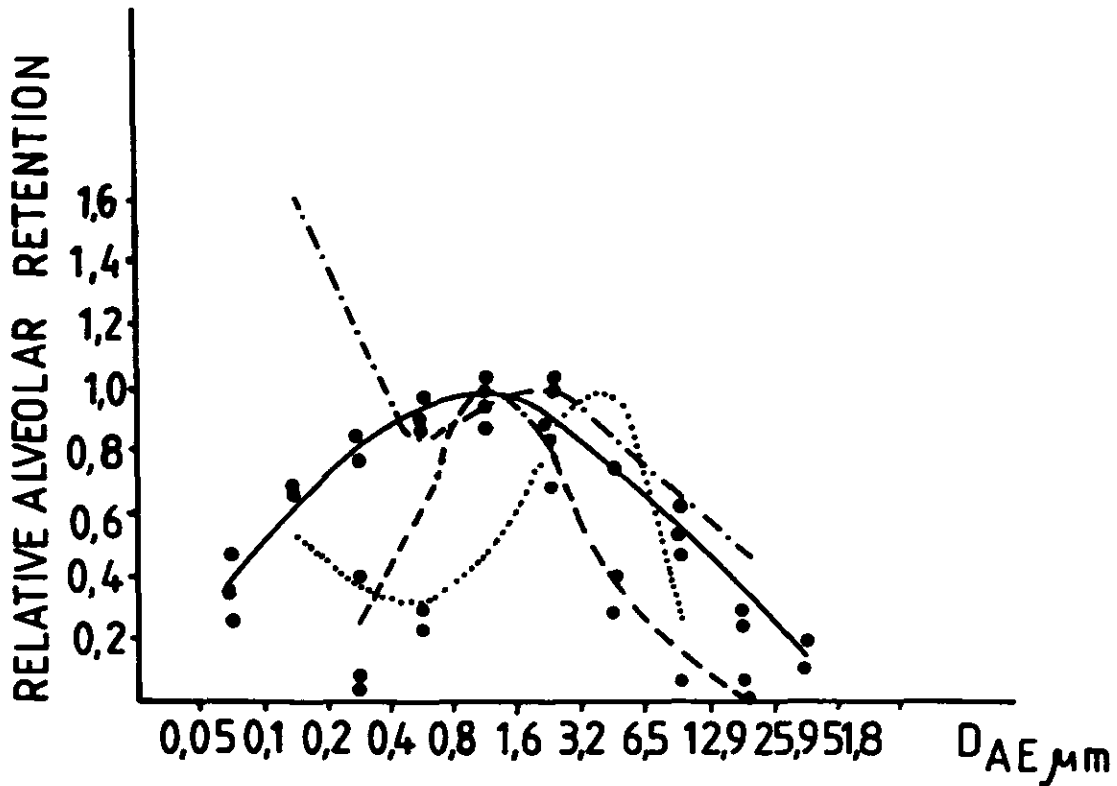

Figure 1. Curves of relative regional alveolar retention of airborne dusts from three ore mines derived on the basis of particle size distribution of lung dusts.

LEGEND

- Mean retention curve derived by Joyce analysis
- - - - - Mean retention curve derived by CC analysis
- · - · - · - Deposition curve of ICRP⁹
- Predictive deposition curve of Yu¹³

Table I
 Characteristics of the Mass Particle Size Distributions
 of Airborne Dusts and Lung Dusts of Miners from Three Ore
 Mines Analyzed with Joyce-Loebl Disc Centrifuge and
 Coulter Counter

Mine	Para- meters	Airborne dusts		Lung dusts	
		Joyce	Coulter	Joyce	Coulter
PMM	Mean MMAD, μm	3.30	3.95	2.13	2.49
	Confid. lim. μm	\pm 3.01	\pm 2.45	\pm 1.60	\pm 1.50
	σ_g	5.30	2.08	3.60	1.66
	Confid lim.	\pm 2.68	\pm 0.66	\pm 2.26	\pm 0.41
	Anal.No	5	24	43	43
	Max.fr.%	32	37	23	53
	Int., μm	1.6-6.5	3.2-6.5	1.6-3.2	1.6-3.2
CMA	Mean MMAD, μm	2.90	3.74	1.86	2.31
	Confid. lim. μm	\pm 2.49	\pm 2.48	\pm 1.70	\pm 1.08
	σ_g	5.00	2.00	2.35	1.83
	Confid. lim	\pm 2.66	\pm 0.71	\pm 1.52	\pm 0.51
	Anal.No	5	18	11	11
	Max.fr %	34	36	42	44
	Int; μm	1.6-6.5	3.2-6.5	0.8-3.2	1.6-3.2
CMB	Mean MMAD	3.92	4.82	2.53	2.57
	Confid. lim. μm	\pm 3.61	\pm 3.45	\pm 3.48	\pm 2.34
	σ_g	4.40	2.10	3.60	1.63
	Conf.lim.	\pm 2.61	\pm 1.01	\pm 2.57	\pm 0.66
	Anal.No	5	5	5	5
	Max.fr.%	36	37	21	50
	Int; μm	1.6-6.5	3.2-6.5	1.6-3.2	1.6-3.2

curve of Yu¹³ and the ICRP curve of Task Group⁹ were also plotted on Figure 1 for comparison, recalculated in the same way.

The relative alveolar depositions with the minimum and maximum values of airborne and lung dusts of the three mines were calculated separately. The values' dispersion is shown on Figure 1 and the data are presented in Table II.

DISCUSSION

The data obtained showed some differences in the particle size distributions of the same dusts, analyzed by both methods. The MMAD determined by Joyce are finer than those determined by CC, while for *og* the contrary was proved. In principle this was expected because the instrumental limitations of CC in sizing of fine particles (smaller than 0.7 μm) as well as Joyce unreliability in sizing of coarse particles (larger than 15–20 μm) are known. But it is necessary to emphasize the fact for two reasons: on one hand to demonstrate the considerable influence on the calculated relative alveolar deposition of the different particle size distributions used, and, on the other hand—to draw the attention of specialists on the need of good knowledge about the limitations of every method or instrument used for particle size analysis, when interpretation of data has to be performed. Thereby useless contradictions due to underestimation of the last reason could be avoided.

Another fact of interest is the fine dispersity of airborne dusts (mean MMAD vary from 3 to 5.0 μm , with real maximal value of the groups examined—5.2 μm by CC analysis). In most of the studies known these values are much higher but they concern coal mine dusts.^{2,5,8} Ore mine dusts are expected to be finer and the authors of this paper have many studies in this field.^{4,10} They have found a considerable presence of submicron fraction of mineral origin in ore mine airborne dusts, as proved with X-ray analysis,¹¹ the same being evidenced for lung dusts, also.

The determination of the alveolar dust deposition by using lung dusts and work environment airborne dusts is connected with some preliminary assumptions: the particle sizes are the leading factor for the dust deposition in the respiratory tract; the “inlet” and the “outlet” dusts, e.g. the airborne and lung dusts are representative and reliable; alveolar deposition, the retention, respectively, of dust is more real when lung dusts are used because the long-term clearance as a total and the changes of dust parameters after continued staying in lung are included.

The data obtained for alveolar deposition (more correctly it should be called alveolar long-term retention) differ to some extent from the referred in the main studies performed—experimental, calculated and predicted. The maxima of the relative alveolar retentions calculated as mentioned above, are

Table II
Size Range Intervals of the Calculated Maximal Enrichment Factors with the Mean and Real Values of MMAD and *og* of the Particle Size Distributions of Airborne and Lung Dusts from Three Ore Mines by Joyce and CC Analyses

Mine	Values of parameters used	Calculated maximal enrichment factors	
		Joyce analysis size intervals	CC analysis size intervals
PMM	Mean	1.6–3.2 μm	1.6–3.2 μm
	Min	0.4–0.8 μm	0.4–0.8 μm
	Max	1.6–3.2 μm	3.2–6.5 μm
CMA	Mean	0.8–1.6 μm	0.8–1.6 μm
	Min	0.1–0.2 μm	0.2–0.4 μm
	Max	1.6–3.2 μm	0.4–0.8 μm
CMB	Mean	0.8–1.6 μm	1.6–3.2 μm
	Min	0.1–0.2 μm	0.8–1.6 μm
	Max	0.8–1.6 μm	1.6–3.3 μm

found to be in the same size range intervals as the maxima of the particle size distributions of lung dusts or are removed toward the fine size ranges—Figure 1 and Table II.

These results are in correspondence with the mathematical model of Diu and Yu.³ To airborne dust with σ_g significantly higher than 2 results a different alveolar dust retention in comparison with the deposition curve of Yu,¹³ predicted for monodispersed aerosols—retention curve calculated with Joyce data on Figure 1. This curve is quite similar in the size range interval 0.5–1.6 μm to the ICRP curve⁹ derived from a lot of different studies. On the contrary, the CC retention curve does not differ in some of the size range intervals considerably from the curve of Yu. The values of σ_g of airborne dusts analyzed by CC are about 2. Morrow⁷ affirms that inhaled dust with $\sigma_g < 2$ have similar deposition in respiratory tract to this of monodispersed aerosols.

CONCLUSIONS

The experimental curve of long-term alveolar retention of inhaled dust from the working environment derived on the basis of the particle size distributions of miners' lung dusts from three ore mines proved that the real alveolar deposition and retention is different from the predicted deposition of monodispersed aerosols.

The study was performed with a comparatively great number of airborne and lung dust samples and can be regarded as reliable.

It is obvious that the polydispersity of dust samples has more considerable influence on the alveolar deposition and retention than it was estimated till now—a problem disregarded to some extent in the experimental studies.

Modern technologies and the mechanizing and automation of working processes lead to increasing of the polydispersity of airborne dusts and namely of the fine particles share. This fact

inevitably will lead to some changes in the understandings about the evolution of the hazard and imposes more attention to be paid to the problems of particle size analyses and the interpretation data.

REFERENCES

1. BDS 2200-85: *Vredni veshestva v vasduha na rabotnata sreda. Metodi za opredeliane koncentraciata na praha.* (In Bulg.)
2. Cartwright, J.: Airborne dust in coal mines: the particle size selection characteristics of the lung and the desirable characteristics of dust-sampling instruments. *Inhaled Particles and Vapours II*. Ed. C.N. Davies, pp. 393-406. Pergamon Press, (1967).
3. Diu, C.K., Yu, C.P.: Respiratory tract deposition of polydisperse aerosols in humans. *Am. Ind. Hyg. Assoc. J.* 44:62-66 (1983).
4. Ivanova-Djoubriilova, St.: *Izsledvane na masovite dispersni razpredelenia na chastisite na fini dispersni prahove, vkluchvashii i submikronnata oblast.* M.S.Thesis, Medical Academy. Sofia (1985) (in Bulg.).
5. Leisteritz, H., Einbrodt, H.J., Klosterkötter, W.: Grainsize and mineral content of lung dust of coal miners compared with mine dust. *Inhaled particles and vapours II*. Ed. by C.N. Davies, pp. 381-390. Pergamon Press (1967).
6. Lippmann, M., Alschuler, B.: Regional deposition of aerosols. *Air pollution and the lung*, Ed. by E.F. Aharonson et al., pp. 25-48. Halsted Press-Wiley, New York (1976).
7. Morrow, P.E.: Aerosol factor affecting respiratory deposition. *International Symposium in Deposition and Clearance of Aerosols in the Human Respiratory Tract*. Bad Gleichenburg, Austria (May 1981).
8. Stöber, W., Einbrodt, H.J., Klosterkötter, W.: Quantitative studies of dust retention in animal and human lungs after chronic inhalation. *Inhaled Particles and Vapours II*, Ed. by C.N. Davies, pp. 409-417. Pergamon Press (1967).
9. Task Group on Lung Dynamics: Deposition and retention models for internal dosimetry of the human respiratory tract. *Health Phys.* 12: 173-207 (1966).
10. Tcherneva, P.: *Izsledvane na dispersnoto razpredelenie na belodrobnoto prahova depo.* M.S. Thesis, Acadical Academy, Sofia (1983).
11. Tcherneva, P., Ivanova-Djoubriilova, St.: Sravnitelno izsledvane na dispersnite razpredelenia na prah ot rudnicnija vasduh i belite drobne na pochninali minjori ot silikosoopasni mini. *International Symposium for Dust Prevention and Dust Diseases*, Vidin, Bulgaria (Sept. 1981).
12. Thomas, K., Stegemann, H.: *Beitr. Silikose-Forsch.*, No 28, 1, 1954).
13. Yu, C.P.: A two-component theory of aerosol deposition in lung airways. *Bull. Math. Biol.*, 40: 693-706 (1978).

THE BIOLOGICAL EFFECT OF PARTICLE SIZE DISTRIBUTION OF QUARTZ COMPONENT IN POLYMINERAL DUSTS

M. DOBREVA, Ph.D. • N. Dancheva, Ph.D. • S. Ivanova, Ph.D. • R. Lukanova, Ph.D.

Institute of Hygiene and Occupational Health, Sofia, Bulgaria

Experimental and epidemiological studies have shown that not in all of the industrial dusts a correlation between the content of respirable quartz and fibrogenicity existed.^{1,9,14,21}

This means that the mass of respirable quartz, which is the basis of contemporary norms for quartz containing dusts in a majority of countries, is not the solely sufficient criterion for their fibrogenicity. During the last 10-15 years the efforts of a number of authors were directed toward the study of the properties of the surface of quartz dusts and finding quantifiable indicators for their fibrogenic activity. A relationship was defined between pathogenic activity of quartz dusts and: concentration of hydroxyle groups,¹⁷ activating energy of the surface,^{12,13} free quartz surface,^{2,7,8} particles size distribution.^{22,23} etc.^{6,16}

Most of the experiments studying the influence of the particle size of quartz dust have been performed with pure quartz dusts. Results of experiments with coal quartz containing dust of different particle size are reported, but they do not present data on particles size distribution of the quartz content.^{2,15}

The results of investigations performed by different authors are consistent and could be summarized as follows: A maximum cytotoxic and fibrogenic effect is manifested by quartz particles of a size from 2-3 to 0.5-1 μm ; at larger or smaller size a decrease in the activity is observed.

Investigations on the size of respirable industrial dusts, as well as of lung dusts from deceased exposed workers show the presence in them of mineral particles of a size within comparatively wide range (from more than 10 μm to 0.01 μm diameter).^{5,10,19}

On the other hand, it is well known that the sizes of quartz particles usually differ more or less from those of the other components of the mixed dust.

In the literature available to us we did not find research data on particle size distribution of the quartz component in mixed dusts. Gade and Luft,⁴ working out a IR-spectrophotometric method for quantitative determination of quartz in industrial dusts by use of double absorption peak, found a relationship between particle size and the ratios of the absorbances at the double absorptions at 798⁻¹ and 775⁻¹ cm to the minimum absorbance between the two absorbance peaks. However, they proposed this method with a view at correction of the influence of the particle size upon the results at quantitative determination of the quartz. The above relationship was later proved

by Dodgson and Whittaker³ for pure quartz. At mixed dusts the absorbance could be influenced also by interfering minerals,^{13,11} which would require the use of correction coefficients, making the method complicated and unreliable.

The aim of the present work was to characterize the particle size distribution of the quartz component of mixed dusts and to assess its biological role by an analysis of: lung dust from deceased exposed miners and some respirable industrial dusts.

MATERIALS AND METHODS

Dusts extracted from the lungs of 26 workers from lead-zinc, copper and uranium mines and tunnels were investigated, as well as samples of respirable dust from the work environment in lead-zinc mines, dina plant and foundry.

X-ray and morphological findings of silicotic changes of different degrees were proved in almost all of the deceased miners with exception of 8 of them, whose lungs contained less than 235 mg quartz.

The lung dust was extracted by formamide digestion after Thomas and Stegemann. Then they were ashed at 600°C and the residue subjected to an analysis of its particle size distribution and mineral composition. For determination of the particle size distribution of the quartz in the mixed dusts the following procedure was applied: the dust sample, suspended in 0.1% water solution of sodium hexametaphosphate was fractionated within the range of 8.9-0.24 μm stockes diameters, calculated on the base of the specific weight of the quartz by sedimentation in a disc centrifuge. The suspensions of the fractions were run through Sartorius membrane filters of 0.05 μm pores size. After that, the membrane filters with the fractions were ashed at 600°C, the residues weighed and the quartz quantity for each fraction determined by IR-spectroscopy. The absorption peak at 695 cm^{-1} was used, because of its being less particle size dependent in the range of 9 to less than 1 μm . To enhance the peak height the ordinate expansion of 5 x was used. So a sensibility of 0.03 mg quartz in the specially prepared pellet was attained. The quartz quantities in it varied from 0.03 to 0.4 mg, the confidence limits at $p = 95\%$ being less than 0.011 mg.

On the basis of the quartz quantities determined in the fractions, the mass particle size distribution of the quartz component was plotted on log-probability paper.

RESULTS

The data of the total lung dust, as well as the parameters of its particle size distribution and that of the quartz components, in particular, are shown in Table I.

It may be seen in the Table that the quantity of the extracted and ashed dust was varying from about 1 to 24 g, in 20 of the cases being between 1 and 10g. The mass median unit density sphere (UDS) diameter of the majority of the dusts analyzed (17 from 26) is between 3 and 5 μm , in 5 of them it is more than 5 up to a maximum of 6.8 μm and in 4—less than 3 μm with a minimum down to 2.4 μm . These data are consistent with the results obtained by Tcherneva¹⁸ in measuring equivalent volume diameter of lung dusts from deceased miners of similar exposure by using Coulter-counter.

The quartz percentage of the dusts mentioned in Table I varies from about 6 to 40% and most frequently between 10 and 30%, its quantity in 22 of the lungs being less than 3 g, in 12—less than 1 g and in 4—between 3 and 5 g.

The mass particle size distribution of the quartz component plotted on the log-probability paper shows a log normal distribution. On Figure 1 the quartz component distribution in three of the dusts examined is illustrated.

The particle size distribution in 19 of the samples investigated is characterized by a larger mass median UDS diameter as compared with that of corresponding total lung dust (See Table I). In 7 of the samples the mass median UDS diameter of the quartz component and that of the total dust, respectively, could be accepted as almost equal, since they differ only by 0.1 to 0.4 μm .

The mass median UDS diameter of the quartz component in all 26 samples examined was over 3 μm ; in 10 of the samples it was between 3 and 5 μm and in 16—larger than 5 μm .

With very few exceptions, the median geometric standard deviations of the distribution of the quartz component were smaller than those of the corresponding total lung dust. Although that the quartz particles in general are larger than those of the other mineral components in the dust and are characterized with a more limited polydispersity, significant quantities of quartz particles with a UDS under 1 μm were found. The mass of the submicron fraction was varying from 3.2 to 15% from the whole mass of the quartz. In 16 of the samples it was between 5 and 10%; in six—more than 10% and only in 4 it was less than 5%. These data are evidencing significant individual differences in the particle size distribution of quartz component in lung dusts.

Table I
Characteristics of Lung Dusts and Their Quartz Component

Case No	Whole extracted lung dust				Quartz component			
	Mass mg	Mass median UDS diameter μm	σg	Quartz content %	Mass,mg	Mass median UDS diameter μm	σg	Submicron fraction %
43	1632	5.5	5.9	7.2	118	10.5	3.8	3.2
74	1148	3.6	3.4	12.3	141	4.8	3.0	7.2
75	1635	4.4	4.8	5.7	92	4.8	3.0	7.2
76	355	3.7	3.9	14.5	51	5.8	3.1	5.7
77	14897	3.6	3.8	13.5	2011	4.8	3.0	7.2
107	24024	3.6	3.8	17.8	4276	3.2	3.2	15.0
109	2950	2.6	5.6	17.8	525	3.3	3.5	16.0
110	8165	5.5	4.7	29.9	2441	7.0	4.7	10.0
111	8450	2.8	4.1	28.1	2374	4.0	3.5	13.0
112	2294	3.9	4.6	16.0	367	5.6	3.5	8.0
113	4482	4.4	4.8	35.8	1605	5.3	3.3	8.0
114	5782	4.2	3.9	27.6	1596	7.4	3.7	6.4
115	5796	3.6	4.3	43.8	2539	7.5	3.3	4.5
117	1222	3.6	4.3	17.4	213	7.5	3.1	4.0
119	17882	3.9	4.2	28.0	5007	3.5	3.2	13.0
120	15029	3.6	4.3	27.5	4133	5.2	3.3	6.0
125	1083	5.2	6.3	13.2	143	5.5	3.4	8.0
126	1396	8.1	6.8	16.8	235	8.2	3.9	6.0
129	1240	3.7	5.3	13.6	169	6.0	3.5	7.5
140	11470	2.4	3.8	26.5	3040	4.0	3.1	10.5
141	7209	4.7	5.9	15.3	1107	4.6	3.3	9.0
142	3522	4.2	7.8	17.4	613	5.5	3.4	8.0
143	7068	3.4	4.6	21.9	1548	5.2	3.3	7.5
144	2062	6.8	6.0	13.3	274	9.0	3.8	4.6
147	8626	4.1	4.4	25.9	2234	5.4	3.4	8.0
148	7736	2.9	4.8	30.7	2375	3.7	13.0	13.5

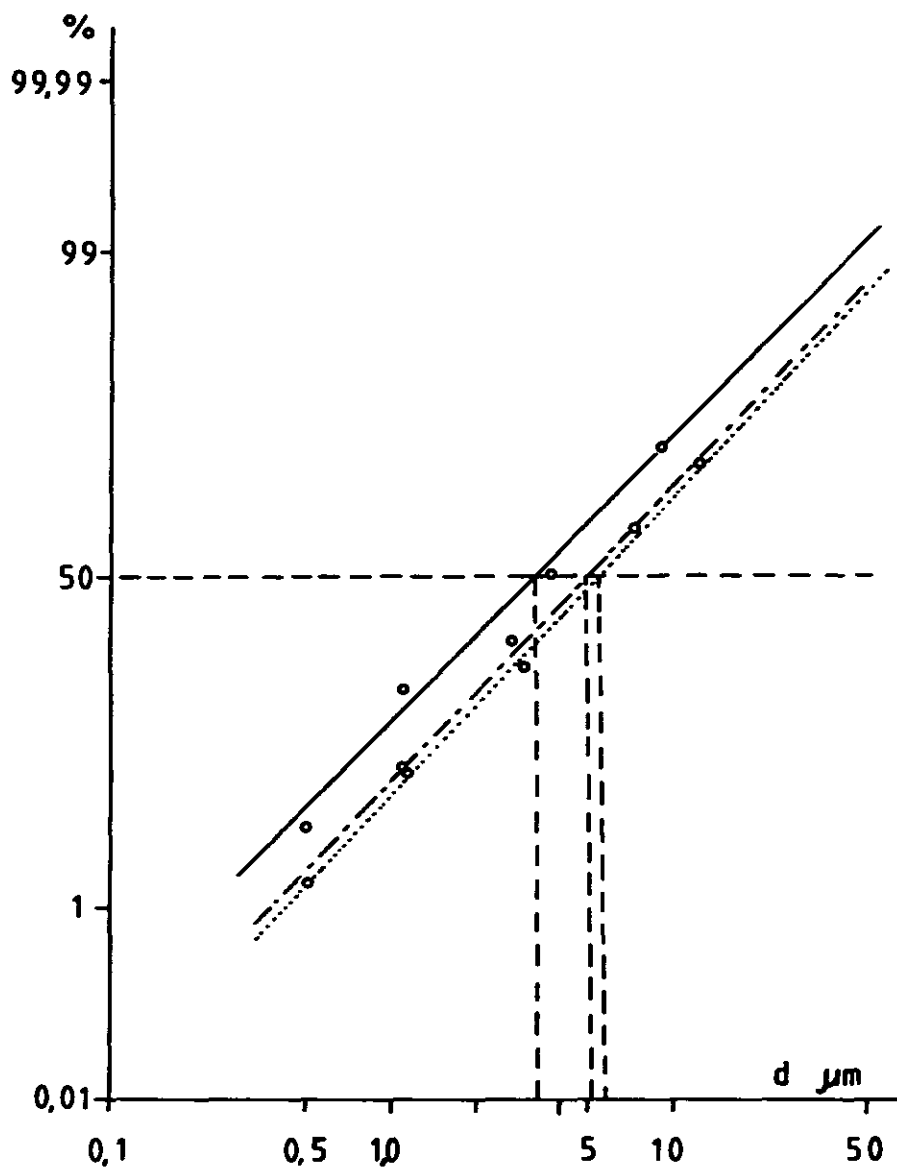

Figure 1. 1. Mass particle size distribution curves of the quartz component of three lung dusts.

Case No. 107 —————
 74 - · - · - · - · - ·
 120 ·········

d — Mass median UDS diameter
 % — Mass percentage of quartz fraction

Research data for respirable industrial dusts are shown in Table II. In these samples significant differences were not obtained between the mass median UDS diameters of the whole dust and of the quartz component. Comparatively near were proved to be the values for these parameters measured for the three sorts of dust (between 5.3 and 6.8 μm), in spite of the differences in their composition. The percentage of quartz particles with UDS diameter less than 1 μm was between 6.8 and 13%.

For assessment of the influence of the particle size of the quartz component on fibrogenicity of mixed dusts, their characteristic data and resulting fibrosis changes in the lung tissue were processed by the program product "Statgraf." The following dust parameters were included in the analysis: total quantity of the extracted dust, its residence time in the lungs, % of the free crystalline silica content, total free crystalline silica content and quantity of the fraction with sizes between 3 and 0.5 μm . Slightly higher correlation coefficient—0.84, was obtained for the quartz fraction within 3—0.5 μm , as compared with 0.83 for the total quartz quantity.

DISCUSSION

The results obtained illustrate the possibility of determining the particle size of quartz component in mixed dusts as a help for the better characterization of both lung and industrial or experimental dusts.

Evidently, this method has the all well-know shortcomings, related with the procedure of lung tissue digestion and dust extraction, ashing at 600°C and preparing liquid suspension for centrifuging etc. In spite of these limitations, we are of the opinion that this method could be a help in elucidating the relationship between the properties of quartz-containing dusts and their pathogenicity.

In our attempt to assess the biological significance of this parameter on the basis of the 26 lung dusts investigated we did not obtain a significant increase of the coefficient of correlation. This fact is perhaps due to the high coefficient of multiple correlation for a comparatively small number of subjects on the background of the number of the variables investigated. The studies continue with a larger group of lung dust cases.

Table II
Characteristics of Respirable Industrial Dusts and Their Quartz Component

Sort of dust	Silica content %	Parameters of particle size distribution			
		Respirable dust		Respirable quartz	
		UDS mass median diameter μm	σ g.	UDS mass median diameter μm	σ g. sub-micron fraction %
Ore mine	9.6	5.9	4.5	6.0	3.3 6.8
Dinas	65.4	5.3	4.1	5.5	3.7 9.0
Foundry	5.3	6.2	12.4	6.6	5.4 13.0

REFERENCES

- Bruch, J., Joos, M.-R., Reisner, M.T.R., Rosmanith, J.: Untersuchungen zur spezifischen Schädlichkeit von Feinstäuben der Steinkohlenbergbau. VII. Vergleich der Ergebnisse von Tier und Zellversuchen. *Ergebnisse von Untersuchungen auf dem Gebiet der Staub- und Silikosebekämpfung im Steinhohlenbergbau*, 14:241-255 Gluckauf, Essen (1983).
- Bruch, J., Gade, M., Henke, A., Resner, M.T.R., Stopschinski, W.: Der Einfluss der Korngrösse und mineralogischen Zusammensetzung von Grubenstäuben auf die Zytotoxizität. *Ergebnisse von Untersuchungen auf dem Gebiet der Staub- und Silikosebekämpfung im Steinkohlenbergbau*. 14:301-312, Gluckauf, Essen (1983).
- Dodgson, J., Whittaker, W.: The Determination of Quartz in Respirable Dust Samples by Infrared Spectrometry—I. *Ann. Occup. Hyg.* 16:373-387 (1973).
- Gade, M., Luft, K. Fr.: Die ultrarotspektroskopische Quarzbestimmung insbesondere von Grubenstäuben. *Staub* 23:353-357 (1963).
- Ivanova-Djubrikova, S.E.: *Izsledvane na masovite dispersirazpredelenija na casticite na finodispersni prahove vlyucvasti i submicronnata oblast*. Disertacia, Izd. Med. Akademia. Sofia (1985).
- Yahuev, A. V., Velichkovskij, B.T., Deeva, N.V., Korkina, L.G.: Biologiceskoe znacenie poverhnostnyh svoistv fibrogeannyh pylej. *Gig. i Sanit.* (:34-37 (1986).
- Kriegseis, W., Scharmann, A., Serafin, J., Beck, E.G., Tilkes, F., Bruch, J.: Die Abhängigkeit der Zytotoxizität SiO₂-haltigen Staube von ihren Oberflächenreinheit. *Ergebnisse von Untersuchungen auf dem Gebiet der Staub- und Silikosebekämpfung im Steinkohlenbergbau*. 14:281-289. Gluckauf GMBH, Essen (1983).
- Le Bouffant, L., Daniel, H., Martin, J.C., Bruyere, S.: Effect of Impurities and Associated Minerals on Quartz Toxicity. *Ann. Occup. Hyg.* 26:625-634 (1982).
- Leiteritz, H., Bauer, E.D., Bruckmann, E.: Konzentrationverhältnisse und mineralische Beschaffenheit den Grubenstaube im westdeutschen Steinkohlbergbau und ihre Bedeutung für die Entwicklung der Staublunge bei Kohlenhauern. *Staub. Reinh. Luft.* 31:185-189 (1981).
- Lippmann, M.: "Respirable" Dust Sampling. *Am. Ind. Hyg. Assoc. J.* 31:138-159 (1970).
- Lukanova, R.T.: *Prilozhenie na UR-spectrofotometriata za kolicestveno opredeljane na quartz i amorfen svoboden siliciev dvoakis v promishlenni prahove*. Disertacija, Med. Akademija. Sofia (1978).
- Robock, K.: Die Wirkung mechanischer, thermischer und chemischer Behandlungen von Siliciumdioxid und Asbest-Stäuben auf Zytotoxizität und Elektronenstruktur. *Beitr. Silikose-Forschung.* 26:111-262 (1974).
- Robock, K., Klosterkötter, W.: Untersuchungen zur Zytotoxizität von SiO₂ Stäuben. *Ergebnisse von Untersuchungen auf dem Gebiet der Staub- und Silikosebekämpfung im Steinkohlenbergbau*. Gluckauf GMBH, Essen. 10:159-162 (1975).
- Seemayer, N.H., Manojlovic, N.: Untersuchungen zur spezifischen Schädlichkeit von 20 Grubenstaube an alveolaren Makrophagen in vitro. In: *Ergebnisse von Untersuchungen auf dem Gebiet der Staub- und Silikosebekämpfung im Steinkohlenbergbau*. 13:225-232. Verlag Gluckauf, Essen. (1981).
- Seemayer, N.H.: Biological Effects of Coal Mine Dusts on Macrophages in Vitro: Importance of Grain size and Mineral Content. *Vllth Int. Pneumoconiosis Conference*. 1985. pp. 513-527. Bergbau—Berufsgenossenschaft—ILO, Bochum. FRG (1983).
- Sikova, W.A., Aronova, G.V., Velichkovskij, B.T.: O vlijanijkationov metallov adsorbirivannyh iz rastvorov solej na nekotoryje svojstva poverhnosti kremnesensorderzhastih pylej. *Prof. Bolezni Pylevoj Etiologii.* 3:138-144. Moskva (1975).
- Sikova, W.A.: *O metodah opredelenija i biologiceskom znacenii gidroksidnogo pokrova kremnezems oderzhastih promyshlennyh pylej*. Disertacija, Leningrad. (1976).
- Tcherneva, P.: *Izsledvane na dispersnata harakteristika na prahovoto depo v beli drobovena minyori*. Disertacia. *Med. Academia. Sofia* (1983).
- Walton, W.H., Dodgson, I. Hadden, G.G., Jacobsen, M.: The Effect of Quartz and Other Noncoal Dusts in Coalworker's Pneumoconiosis. *Inhaled Particles IV:669-690*. Pergamon Press. Oxford (1977).
- Velichkovskij, B.T., Aronova, G.V., Starkov, P.P., Belobragina, G.V.: Sravnitel'no expermental'nyje issledovanija zavisimosti fibrinogenosti kremnezema ot mehanizma obrazovanija i dispersnosti pylevyhceistic. *Bor'ba s silikozom.* 18 pp. 191-198. Nauka. Moskva (1970).
- Velichkovskij, B.T., Artjunov, V.D., Kruglikov, G.G., Batsura, Ju.D., Fedorova, V.M.: O mehanizme samoociscenija lyoghnih ot pyli. *Gig.Tr. Prof.Zabol.* 4:31-36 (1979).

CHEMILUMINESCENCE AND BIOLOGIC REACTIVITY OF FRESHLY FRACTURED SILICA

N.S. DALAL • V. Vallyathan • N. Leelarasamee • V. Castranova • K. Van Dyke

Chemistry and Pharmacology Departments, West Virginia University, and Division of Respiratory Disease Studies, National Institute for Occupational Safety and Health, Morgantown, WV 26505, USA

INTRODUCTION

Silicosis is the chronic fibrosing disease of the lungs caused by the inhalation of crystalline silica. However, inhalation of crystalline silica, may induce three distinctly different disease patterns; i.e., chronic silicosis, accelerated silicosis, and acute silicosis. These three disease patterns differ in their pathologic characteristics, clinical symptoms, onset of disease, and mortality. Many studies in the past have focused on the elucidation of mechanisms involved in the development of chronic silicosis. We recently reported that freshly fractured silica has surface properties that could make it more reactive with lung tissue than aged silica, and that this unique reactivity of freshly fractured silica may be involved in the pathogenesis of acute silicosis (Dalal et al., 1986; Vallyathan et al., 1988; Shi et al., 1988). Because freshly fractured silica could contain some moieties in an "excited state," due to the breakage of silicon-oxygen bonds, we postulated that the de-excitation of these moieties could produce light which could be monitored by a luminescence measurement technique. In addition, if this "excited state" of silica could trigger a greater biologic response by phagocytic cells, this activation could be monitored by a chemiluminescence technique in the presence of appropriate enhancers.

This investigation describes for the first time the use of luminescence in the study of freshly fractured silica and its properties. Enhanced biologic reactivity of the freshly fractured silica with alveolar macrophages was monitored by the chemiluminescence technique.

MATERIALS AND METHODS

Native silica was obtained from the dust bank of the Generic Respirable Dust Technology Center, Pennsylvania State University, State College, PA, and ground for 30 min in an agate ball mill. It was then sieved through a 20 micron mesh filter and used within 10 min as fresh silica or stored in glass bottles for aging. X-ray energy spectrometry and X-ray powder diffraction studies on representative samples were made to confirm the mineralogic purity. All the silica samples were found to be 99% pure with minimal detectable contamination by metal ions.

Luminescence of freshly ground silica was measured from 5 g samples in plastic scintillation vials using a Packard Liquid Scintillation Counter operated in the out-of-coincidence mode. After grinding, the samples were stored in dark for 10 min,

and luminescence was monitored over a period of several hours and days. The effect of aqueous solutions on the generation of luminescence was studied in HEPES-buffered medium (145 mM NaCl, 5 mM KCl, and 10 mM HEPES, pH 7.4). Freshly ground silica (5 g) was added to 5 ml of HEPES-buffered medium, the vials stored in dark for 10 min, and samples counted at various time intervals. The effect of scavengers on luminescence was investigated by the addition of 5 g freshly ground silica to HEPES-buffered medium containing 125 $\mu\text{g/ml}$ superoxide dismutase (SOD), 125 $\mu\text{g/ml}$ catalase, or 100 mM 5,5-dimethyl-1-pyrroline-1-oxide (DMPO).

Biologic reactivity of freshly ground silica was monitored as lucigenin-enhanced chemiluminescence at 37°C using a Berthold Luminometer, Model 9500. Alveolar macrophages were obtained by the broncho-pulmonary lavage of Sprague-Dawley male rats with calcium and magnesium-free Hank's balanced salt solution. Repetitive lavages were pooled (total volume of 80 ml) and was sedimented by centrifugation at 500 g for 5 min. Cells were washed and resuspended in HEPES-buffered medium containing 1 mM calcium and 5 mM glucose. With the aid of trypan-blue and hemocytometry, cell viability and counts were determined microscopically. Results of these studies indicate that approximately 90% of the lavaged cells were viable alveolar macrophages. Samples of alveolar macrophages (1×10^6) were then incubated with 20 $\mu\text{g/ml}$ silica in 0.5 ml HEPES-buffered medium at 37°C. The buffer contained 2.5×10^{-8} M lucigenin as an enhancer of chemiluminescence. Silica-induced reactivity of alveolar macrophages was then monitored over time for 40 min.

RESULTS

Figure 1 shows the results of luminescence studies on freshly ground silica in comparison with that of aged dust. Aged dust, on the other hand, showed a steady minimal baseline intensity of light emission, most likely due to "fluorescence." This intensity of light emission was greater when samples were not dark equilibrated for 10 min. Therefore, we consider that, this basal emission to be due to fluorescence excited by the ambient light. The data clearly indicate that freshly ground silica emitted substantially more light than aged silica. The intensity of this light emission declined with time after grinding and exhibited half-life of approximately 40 min.

In order to find whether contact with a biologic medium would quench the luminescence instantaneously, luminescence

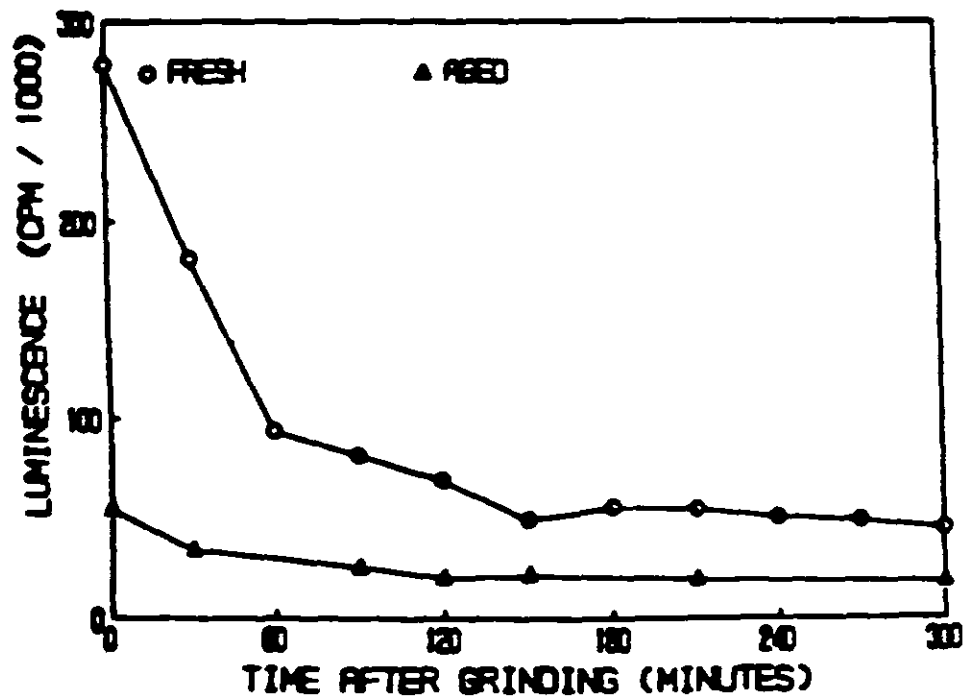

Figure 1. Luminescence of freshly ground and aged silica compared to show the greater intensity of time dependent luminescence associated with freshness.

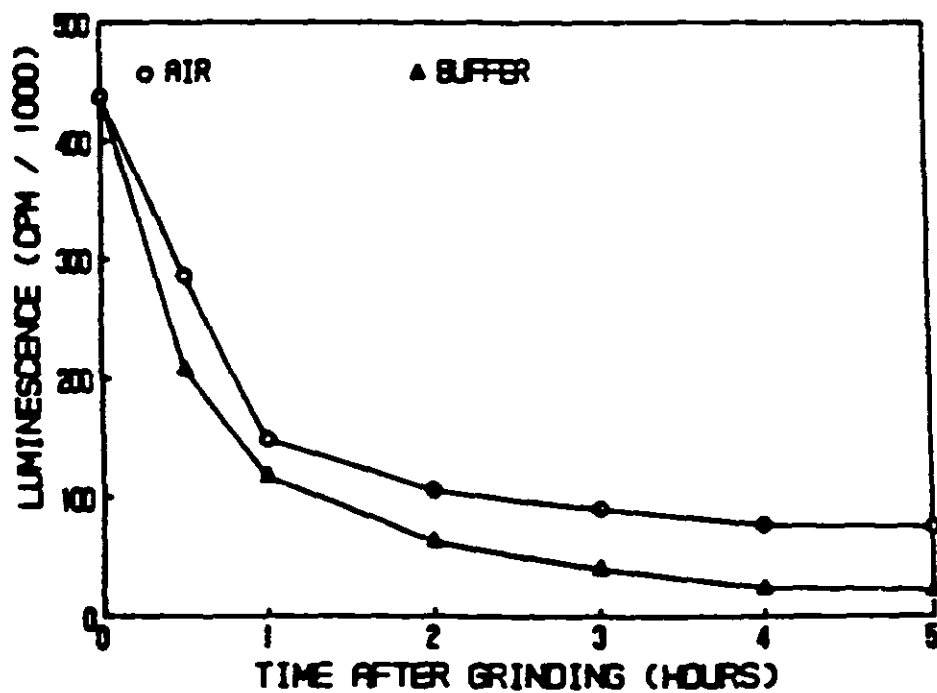

Figure 2. Luminescence of freshly ground silica in air and in HEPES-buffered medium.

measurements were made on freshly ground silica dispersed in HEPES-buffered medium. It is evident from the data presented in Figure 2 that fresh silica suspended in the biologic medium emits substantial light suggesting that the reactive surface sites on freshly ground silica are not immediately quenched after contact with biologic media.

Effect of free radical scavengers on the light emission intensity is presented in Figure 3. It is seen that luminescence of freshly ground silica was inhibited by approximately 71% with SOD, while catalase and DMPO inhibited the light emission by 88% and 97%, respectively.

Figure 4 shows the effect of freshly ground silica on alveolar macrophages stimulation and resulting release of reactive species of oxygen, monitored as chemiluminescence in the presence of an enhancer, lucigenin. Alveolar macrophages incubated with freshly ground silica (20 $\mu\text{g}/\text{ml}$) generated chemiluminescence which peaked approximately 8 min after exposure to silica. This silica-induced activation of alveolar macrophages was substantially greater with freshly ground silica as compared to silica aged for 24 and 48 hours (Figure 4).

DISCUSSION

Data from the present study indicate that freshly fractured silica emits light which can be monitored by luminometry or a liquid scintillation technique. These studies also indicate that the luminescence generated by silica is not quenched instantly in biologic medium but can be inhibited to a substantial degree by SOD, catalase, and DMPO. These results suggest that excited surface sites result from the cleavage of silica and that these surface sites can react with aqueous media to form reactive oxygen species as a source of emission of light detected by the luminescence technique. We have previously shown that silicon-oxygen radicals and possibly O_2 radicals are formed during grinding of silica (Dalal et al., 1986; Shi et al., 1988). We have also shown that these radicals undergo a time dependent decay in ambient air (Dalal et al., 1986; Shi et al., 1988). We tentatively assign the light emission from the freshly fractured silica to the de-excitation of these radicals

and/or the silicon-oxygen radicals.

Our studies also indicate a correlation between light emission by freshly fractured silica and potential for biologic reactivity. The increased activation of alveolar macrophages induced by freshly ground silica as monitored by chemiluminescence indicates excessive secretion of reactive oxygen species during phagocytosis. We have shown previously that generation of reactive species of oxygen on silica during grinding can cause the generation of OH radicals. The presence of these increased cytotoxicity reactive species has been related to lipid peroxidation (Vallyathan et al., 1988). Results of the present study support our hypothesis that the reactive species associated with fresh silica together with those generated by alveolar macrophages in response to fresh silica may induce an oxidant stress and overwhelm the protective anti-oxidant systems of lung in occupational exposures, such as sand-blasting, tunnelling, drilling, or silica flour mills where freshly fractured silica dust is generated. We, therefore, conclude from these studies that oxidant stress may play a role in the etiology of acute silicosis.

REFERENCES

1. Dalal, N.S., Suryan, M.M., Jafari, B., Shi, X., Vallyathan, V., and Green, F.H.Y.: Electron spin resonance detection of reactive free radicals in fresh coal dust and quartz dust and its implication to pneumoconiosis and silicosis. In: *Respirable Dust in the Mineral Industries: Health Effects Characterization and Control*, Editors R.L. Frantz and R.V. Ramani, 1986. The Pennsylvania State University, University Park, PA. pp 24-32.
2. Vallyathan, V., Shi, X., Dalal, N.S., Irr, W., Castranova, V.: Silicon-oxygen radicals and their role in acute silicosis. *Am. Rev. Respir. Dis.* 137:404, 1988.
3. Vallyathan, V., Shi, X., Dalal, N.S., Irr, W., Castranova, V.: Generation of free radicals from freshly fractured silica dust: potential role in acute silica-induced lung injury. *Am. Rev. Respir. Dis.* 138:1213-1219, 1988.
4. Shi, X., Dalal, N.S., Vallyathan, V.: ESR evidence for the hydroxyl radical formation in aqueous suspensions of quartz particles and its possible significance to lipid peroxidation in silicosis. *J. Environ. Toxicol.* 25:237, 1988.
5. Dalal, N.S., Shi, X., Vallyathan, V.: Oxygenated radical formation by fresh quartz dust in a cell-free aqueous medium and its inhibition by scavengers. In: *The Proceedings of VIIth International Conference on Pneumoconioses*, Pittsburgh, PA. Editor Molly Pickett-Harner.

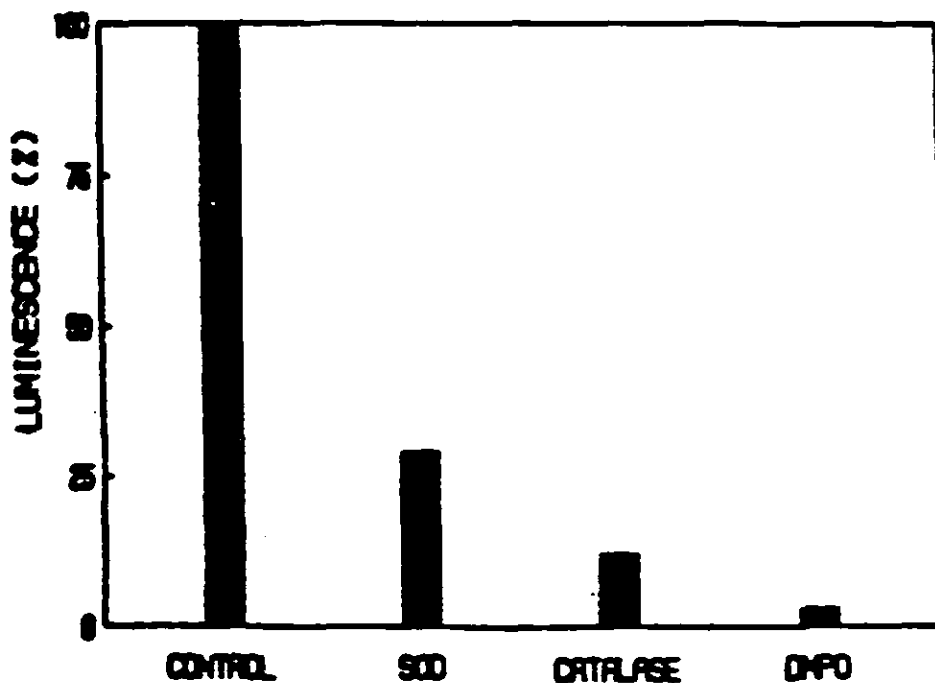

Figure 3. Effect of SOD, catalase, and DMPO on luminescence by freshly ground silica.

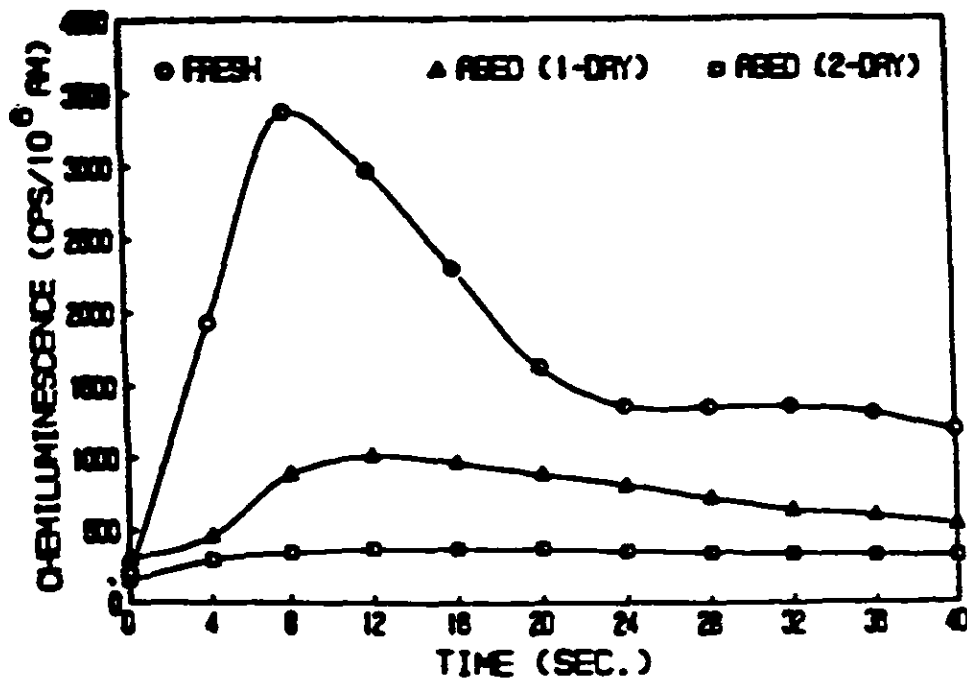

Figure 4. Effect of freshly ground and aged silica on chemiluminescence by alveolar macrophages.

THE INJURIOUS EFFECT OF QUARTZ ON CELL MEMBRANES AND THE PREVENTIVE EFFECT OF ALUMINIUM CITRATE AGAINST QUARTZ

CHENG J. CAO,* M.D. • Shi J. Liu,* M.D. • Ke C. Lin,† Ph.D.

*Dept. of Occupational Health, School of Public Health

†Dept. of Biophysics, School of Basic Medicine

Beijing Medical University 100083, Beijing, China

ABSTRACT

The injurious effect of quartz on the membranes of macrophages as well as erythrocytes and the anti-injurious effect of aluminium citrate (Al citrate) were examined. The comparative study with titanium dioxide was carried out simultaneously. The results from the present study show that quartz can cause the increases of fluidity and permeability of macrophage membranes and reduce membrane-bound water of erythrocytes, resulting in the membrane dehydration. Furthermore, quartz can change electrophoretic behaviour of macrophages by increasing the negative charge density and electrokinetic potential on these cells surface. The effect of titanium dioxide on cell membranes however is very different from quartz in intensity and kinetics, and is not affected by Al citrate. The relationship between these effects was discussed and a possible mechanism was proposed for the interaction of quartz with membrane lipids resulting in membrane damage.

The preventive effect of Al citrate against membrane damage by quartz was also demonstrated. In general, the addition of Al citrate can recover all alternations caused by quartz, so that the stability and order structure of cell membranes were maintained. A hypothesis about the action of Al citrate on the surface of quartz particles to exert its anti-injurious effect was postulated in this paper.

INTRODUCTION

It is generally accepted that the cytotoxic effect of quartz on alveolar macrophages is a key step in the pathogenesis of silicosis.¹⁻² The cytotoxic mechanism postulated by Allison depends on mainly the release of hydrolytic enzymes from lysosomes after the phagocytosis of quartz by macrophages followed by cell damage.³ However, a question that remains unanswered is whether the toxic particles directly damage the plasmic membranes of macrophages. It is well known that the contact of quartz with the cell membranes is the first event during the process of phagocytosis, no matter how the particles are uptaken into the interior of these cells. For this reason, it is desirable to elucidate the molecular interactions between quartz and cell membranes from the viewpoint of membrane toxicology.

The therapeutic effects of Al citrate on the experimental animal and patients with silicosis have been demonstrated in our previous experimental studies and clinical observations. It was also found that Al citrate is able to prevent effectively macrophages from the cytotoxicity of quartz instead of the inhibition of fibrosis.⁴⁻⁶ It is, therefore, necessary to clarify its pharmacology with the goal being to provide the experimental and theoretical evidence for screening the preventive measurments and therapeutic drugs for silicosis.

On the other hand, titanium dioxide, a less toxic and usually classified as "inert dust,"⁷ was also studied in this work for comparsion.

MATERIALS AND METHODS

Macrophages were harvested from lung of guinea pig through lavage. The erythrocyte membranes of rabbit were prepared as described elsewhere.⁸

Quartz (99% pure) was supplied by Hygiene Institute of Chinese Prophylatic Medical Center. Particles diameter is less than 5 μm , among which 89.3% is less than 2 μm . Titanium dioxide with the same purity and size was selected as a control. Al citrate with Al of 9.26% was supplied by Pharmaceutical Factory of Beijing Medical University. Fluorescence probe, 1,6-diphenyl-1,3,5-hextriene (DPH) was purchased from Sigma. Adenosine 5'-triphosphate disodium salt (ATP) was produced by Shanghai Biochemical Institute of Academia Sinica.

Fluorescence polarization was determined by spectrophotofluometer Model MPF-4. Potassium (K⁺) content of cells was detected by Fire Atomic Absorption Spectrophotometer Model Y-3.⁹ Na⁺-K⁺-ATPase activity was determined using the method described by Pan H.Z.¹⁰ Viscosity of medium and surface charge of cells were measured by viscosimeter Model E and Cell Electrophoresis Autotimer Model SX-2, respectively.¹¹ Membrane-bound water was determined employing the method of sorption isotherms and Nicolet Fourier Transform Infrared Spectrometer Model 5DX.⁸⁻¹²

There were on the average five samples in each group. Data

were presented as mean + standard error and significance was estimated by analysis of variance. Pairing data about fluidity and permeability were treated by linear correlation and regression.

RESULTS

Cell Membrane Lipid Fluidity

We began with the examination of membrane fluidity of macrophages by measuring fluorescence polarization P and microviscosity of membrane-bound DPH. As shown in Figure 2, P values of quartz I and II groups dropped down continuously with the cultural time, resulting in more fluid membranes. It is important that the effect of quartz on membrane fluidity is not only time-dependent, but also dose-dependent (Figure 1). However, the change of membrane fluidity by titanium dioxide is much lower than that of quartz group and tends to be recovered rapidly (Figure 1).

Compared with quartz control, fluidity was decreased (e.g. P value raised) when quartz plus Al citrate was added into the cells simultaneously, although Al citrate did not affect membrane fluidity alone. Similarly, the effect of Al citrate against quartz is dose-dependent (Figure 1).

Permeability of Cell Membrane to K⁺

Table I presents the differences between the groups treated by several ways in membrane fluidity and permeability to K⁺. It is interesting that the increased permeability of macrophage membranes to K⁺, that is, K⁺ content of the cells was reduced, by quartz was accompanied with increasing membrane fluidity. Statistic analysis indicates the effects of quartz on both these properties of macrophage membranes exhibit very significant correlation (for instance, using η and K⁺ as X and Y, respectively, $r=0.917$, $P < 0.001$, $Y=9.059X-0.011$) (Figure 3).

Like that on fluidity, Al citrate did not influence permeability of macrophage membranes to K⁺ by itself, but it prevented

acting efficiently against the effect of quartz, except that macrophages were pretreated with Al citrate (Table I).

It is seen from Table I that membrane permeability of titanium dioxide group was lowered only slightly and it seems that no exact relationship exists between the changes of fluidity and permeability. Another important difference from quartz is that the effects of titanium dioxide are unable to be affected by Al citrate.

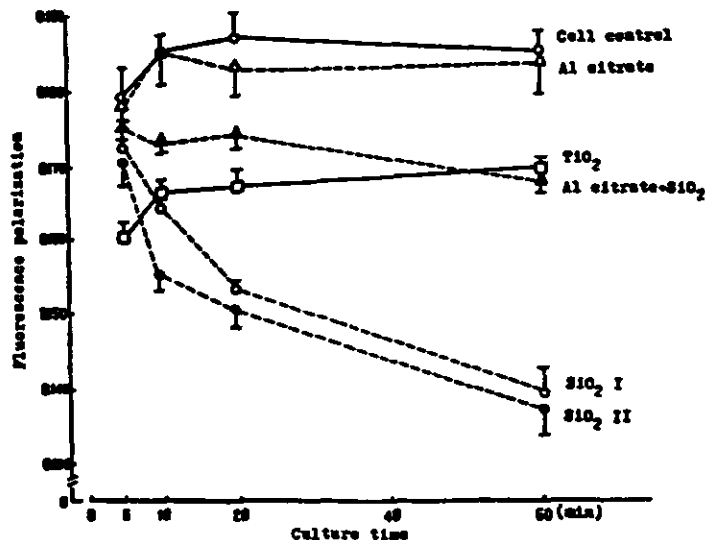

Figure 2. Kinetic curve of DPH fluorescence polarization labelled in macrophage membrane

SiO₂I: the simultaneous addition of DPH and SiO₂ to cell medium

SiO₂II: the addition of SiO₂ to cell medium followed by the addition of DPH

The dose of SiO₂ or TiO₂ was 1 mg; the dose of Al citrate was 0.5 mg Al.

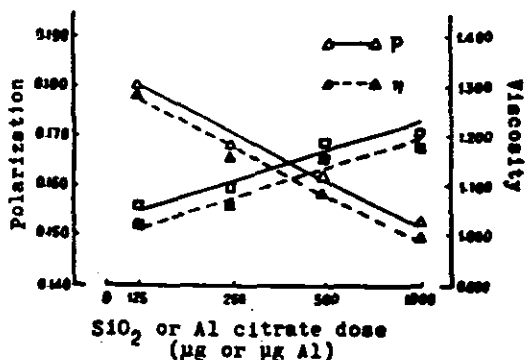

Figure 1. Dose-effect relationships of the effect of SiO₂ on fluorescence polarization (P) of macrophage membrane-bound DPH and lipid viscosity (η) and the antagonistic effect of Al citrate against SiO₂.

△ ——— △ SiO₂: □ ——— □ SiO₂ (1 mg) + Al citrate
 ▲ ——— ▲ ——— ——— ———

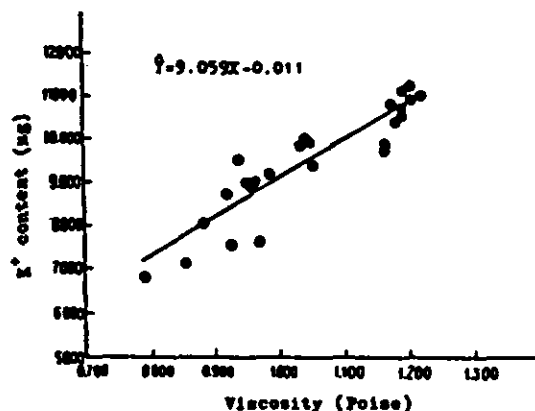

Figure 3. Scatter diagram of membrane lipid viscosity with K⁺ concentration of macrophages administrated with SiO₂.

It may be involved in K^+ permeability, however, no change in the activity of $Na^+-K^+-ATPase$ could be found after the treatment of three cell preparations with quartz (Table II), indicating that the increased permeability is related closely to the change in lipid fluidity.

Membrane-bound Water

Membrane hydration of quartz group at the different relative humidities (RH), particularly at higher RH, was reduced markedly from sorption isotherms curve (Figure 4) and data listed in Table III. In IR spectra, VOH shifts largely to lower frequency (Figure 5) and the results represented in Figures 5 and 6 are identical, for instance, at 76% RH, the hydration and VOH peak position in both of control and quartz groups are 18.8% and 3535 cm^{-1} , and 10.1% and 3447 cm^{-1} , respectively. It is clear that the dehydration of cell membranes was caused by quartz and has a significant dose-effect relationship (Table IV).

Whereas membrane hydration in either quartz plus Al citrate group or the pretreated quartz group with Al citrate is higher than quartz control (Table III) and their VOH peak position shifts towards the higher frequency (Figures 5, 6). The effect of Al citrate against quartz exists also a dose-effect relationship (Table IV). Membrane-bound water under the treatment by the different ways is presented in Figure 7. The similar results are found from two quartz groups pretreated with Al citrate and $AlCl_3$. However, the effect of titanium dioxide on membrane-bound water is not only lower than quartz, but also was not recovered by the pretreatment of Al citrate (Figure 7).

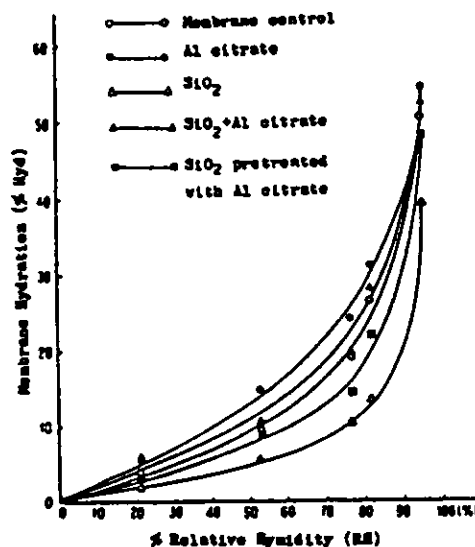

Figure 4. Sorption isotherm of water on red blood cell membranes treated by different ways at 20°C .

20mg SiO_2 : 8.333 mg Al(Al citrate)

Table I
Polarization (P) of Membrane-bound DPH and Its Lipid
Microviscosity (η) with K^+ Content of Macrophages

Groups	time (min)	P	η	K^+
		$\bar{X} \pm SE$	$\bar{X} \pm SE$	$\bar{X} \pm SE$
Control	20	0.185 ± 0.003	1.352 ± 0.042	11.557 ± 0.149
	60	0.184 ± 0.002	1.329 ± 0.018	11.533 ± 0.099
SiO_2	20	0.152 ± 0.002	0.984 ± 0.019	9.239 ± 0.192
	60	0.141 ± 0.003	0.885 ± 0.031	7.431 ± 0.205
$SiO_2 + Al$ citrate	20	0.171 ± 0.001	1.183 ± 0.007	10.612 ± 0.227
SiO_2 pretreated with Al citrate	20	0.172 ± 0.001	1.195 ± 0.010	10.694 ± 0.254
Cell pretreated with Al citrate	20	0.185 ± 0.004	1.350 ± 0.043	11.608 ± 0.181
Cell pretreated with Al citrate + SiO_2	20	0.154 ± 0.003	1.000 ± 0.029	9.498 ± 0.205
TiO_2	20	0.164 ± 0.002	1.104 ± 0.019	10.616 ± 0.264
	60	0.163 ± 0.002	1.096 ± 0.025	9.384 ± 0.231
$TiO_2 + Al$ citrate	20	0.164 ± 0.002	1.111 ± 0.022	10.549 ± 0.258
TiO_2 pretreated with Al citrate	20	0.163 ± 0.001	1.100 ± 0.015	10.647 ± 0.279

K^+ ($\mu\text{g}/2 \times 10^6$ cell); 1mg SiO_2 or TiO_2 ; 0.5mg Al

Table II
 Na⁺-K⁺-ATPase Activities (μM Pi/mg protein)
 of Three Cell Preparations

Groups	adhesion cell	suspension cell	cell homogenate
	$\bar{X} \pm SE$	$\bar{X} \pm SE$	$\bar{X} \pm SE$
Control	0.672±0.099	0.806±0.144	1.156±0.190
SiO ₂	0.646±0.113	0.794±0.142	1.099±0.232
Al citrate	0.616±0.099	0.799±0.137	1.136±0.057
SiO ₂ +Al citrate	0.666±0.119	0.794±0.128	1.162±0.168
TiO ₂	0.627±0.095	0.862±0.192	1.098±0.187

The doses of SiO₂ and Al citrate were 300μg and 125μg Al respectively; The enzymatic activities were determined at 1 hr. of culture.

Table III
 Hydration of Erythrocyte Membranes of Several Groups
 at the Different Relative Humidity (RH)

Groups	Hydration(%)				
	95%RH	81%RH	76%RH	52%RH	20%RH
Control	50.2	26.1	18.8	9.2	4.0
SiO ₂	39.1	13.3	10.1	5.8	2.3
Al citrate	54.1	30.9	23.8	14.7	5.7
SiO ₂ +Al citrate	52.0	28.1	19.4	10.6	5.8
SiO ₂ pretreated with Al citrate	47.5	21.6	14.3	9.1	3.2

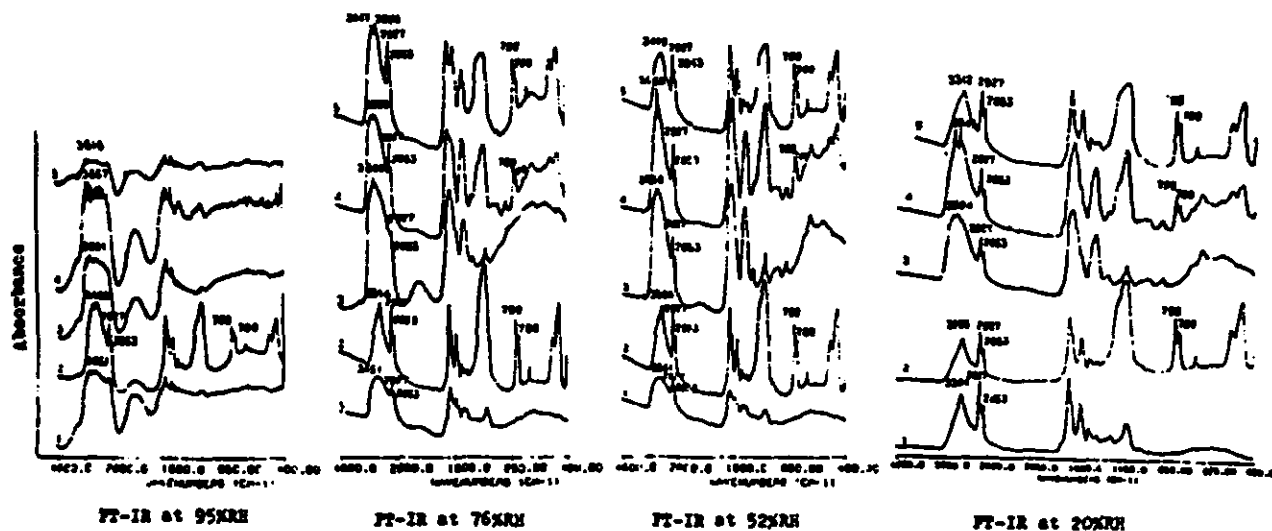

Figure 5.

- | | | |
|---------------------|----------------------------------|--|
| 1. Membrane control | 3. Al citrate | 5. SiO ₂ pretreated with Al citrate |
| 2. SiO ₂ | 4. Al citrate + SiO ₂ | 2. 0mg SiO ₂ : 0.833 mg Al |

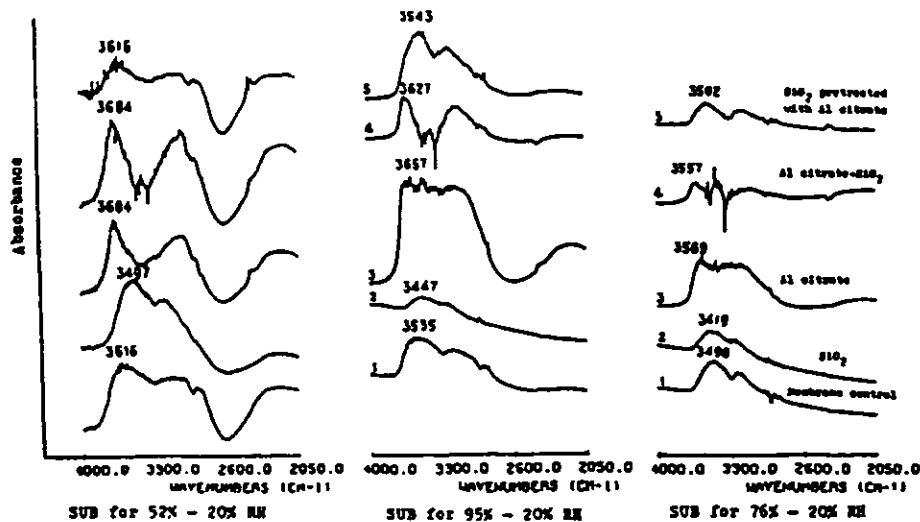

Figure 6.

Table IV
The Effects of Different Doses of SiO₂ and Al Citrate on Membrane-bound Water

SiO ₂ (mg)	$\nu_{OH}(cm^{-1})$	Al(mg)	$\nu_{OH}(cm^{-1})$
0.5	3395	0.417	3419
1.0	3364	0.833	3558 3460
2.0	3314	1.668	3607 3493
3.0	3288		

* SiO₂(2.0mg)+Al citrate

Cell Membrane Charge

As shown in Figure 8, electrophoretic mobility of macrophages sped up rapidly following the addition of quartz. The result indicates that the interaction of quartz with macrophage surface causes increasing negative electrophoretic potential (ξ -potential) and charge density on the membrane surface. Similar to that on membrane fluidity and permeability, the effect of quartz on membrane charge of macrophages has also significant time-dependent and dose-dependent relationships (Figures 8, 9).

Al citrate can decrease electrophoretic mobility of macrophages by itself like its effect on membrane-bound water. The effect of quartz is almost abolished by the addition of a high dose of Al citrate (Figure 9). Of particular interest, the effect of quartz on membrane charge can be decreased by the pretreatment with Al citrate (Figure 8).

As illustrated in Figure 8, the increment by titanium dioxide is lower and its kinetics are very different from that of quartz, although it increased also electrophoretic mobility of macrophages.

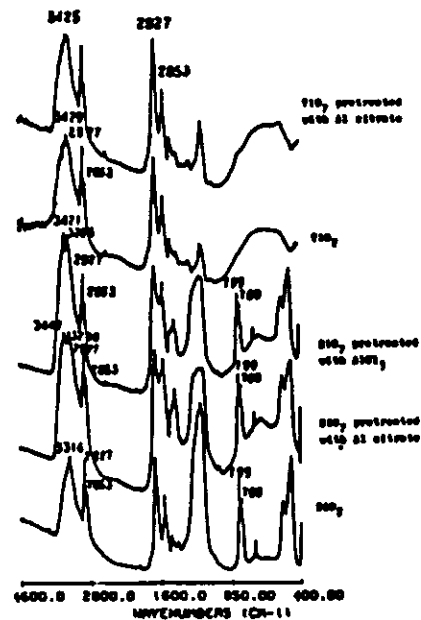

Figure 7. PT-IR of erythrocyte membranes treated by the different ways at 76% RH. 2.0 mg SiO₂ or TiO₂

DISCUSSION

In previous studies, the cytotoxicity of quartz on macrophages was evaluated usually by measuring the activities of LDH and ACP and cell death rate.^{3,6,13-15} The enzymatic activities may reflect indirectly the plasmic and lysosomal membranes damage caused by quartz, but their changes did not occur until after one hour of the incubation of cells with quartz. It is obvious that the indirect interaction between quartz and macrophage membranes, particularly its early effect need to be observed in order to establish the injurious effect of quartz on the membranes. It is for this purpose that the present studies was carried out.

Membrane fluidity plays an important role in membrane function.^{16,17} Fluorescence Probe DPH used in this experiment can be inserted into the hydrocarbon region of lipid bilayers and fluorescence polarization depends on microviscosity of that region. The decrease of P under the action of quartz elucidates that the motion of lipidic molecules was increased due to the lowered membrane lipid microviscosity, resulting in disruption of membrane structure. Moreover, the fact that quartz can increase fluidity of liposomes prepared from lecithin and cholesterol also suggests that quartz interacts mainly with membrane lipids.¹⁸

In regard to the study of permeability, we have demonstrated that the reduction of K^+ content in macrophages can anticipate the enhanced activities of LDH and ACP in culture medium following the addition of quartz to these cells and is responsible for the cytotoxicity.⁶ The present paper establishes further the correlation between both changes of permeability of macrophage membranes to K^+ and their membrane fluidity by quartz. Likewise, the mechanism of the

increased permeability is considered to be associated with the effect of quartz on membrane lipids, but not on $Na^+-K^+-ATPase$.

Bound water is a major component of biological membranes and is required for the structural stability of lipid bilayers and the normal function. A novel information about the effect of quartz on membrane "water structure" was obtained from the experiment of membrane-bound water of erythrocytes. The membrane IR spectra show hydration-dependent changes in the stretching vibration band of bound water, namely VOH shifted to the lower frequency with decreasing hydration. The result from subtract spectra (SUB), which can exclude absorbance of several groups besides water at 3000-3800 cm^{-1} region, is consistent with the effect. A turning point of membranes hydration from sorption isotherms curve is at about 76% RH, at which hydration of normal erythrocytes membranes is 18.8% and its VOH peak position is 3535 cm^{-1} , whereas hydration of quartz group is only 10.1%, and its VOH peak position exhibits red shift to 3447 cm^{-1} . The decrease of membrane-bound water does not provide lipidic molecules with a necessary condition required for hydrophilic and hydrophobic interactions, so that the order degree of biomolecular layers was not maintained. Indeed, Clifford et al have found the changes of structure, such as phase separation of cholesterol from lipid, in membrane dehydration.¹⁹ Thus dehydration by quartz is associated with increasing fluidity or permeability. On the other hand, charges on the membrane surface will alter relatively because the dehydration has made water molecules separate from some groups on membranes which are bound to them. This is further supported by the results from cell electrophoretic experiments.

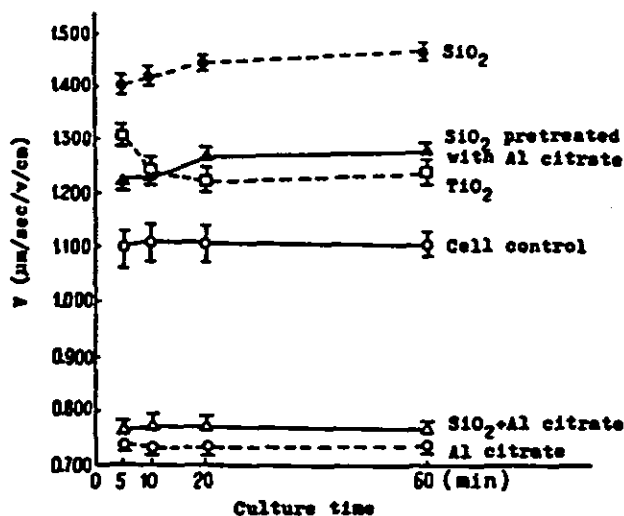

Figure 8. Kinetic curve of electrophoretic mobility (V) of macrophages treated by different ways.

500 μ g SiO_2 or TiO_2 ; 250 μ g Al

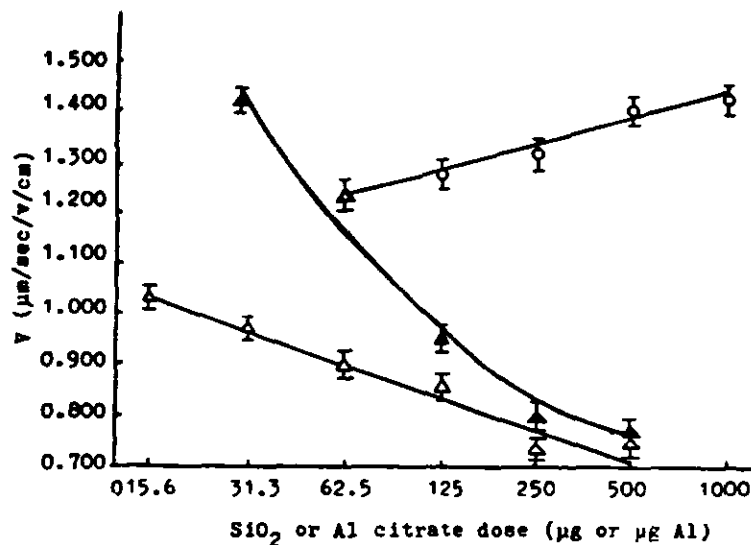

Figure 9. Dose-effect relationships of SiO_2 , Al citrate and SiO_2 (500 μ g) + Al citrate on electrophoretic mobility (V) of macrophages.

○—○ SiO_2 ; △—△ Al citrate; ▲—▲ SiO_2 + Al citrate

It seems more possible that quartz interacts with the positively charged groups, such as $-N^+(CH_3)_3$ riched in membrane phospholipids, so positive charge on the cell surface is neutralized partly and negative charge density increases relatively. Nash et al and Depasse et al presented the indirect evidence that quartz is easy to attract amide phosphate and quaternary ammonium groups and suggested that the attraction is responsible for haemolysis of quartz toward erythrocytes.²⁰⁻²¹

Compared to quartz, the effects of titanium dioxide on cell membranes are not only much lower in intensity, but also very different in kinetics, for instance, the changes of fluidity, permeability and cell electrophoresis can not enhance permanently with the culture time, whereas tended to recover rapidly and remained constant. Of interest, the results from morphology is quite in accordance with biophysical and biochemical determinations.²² Whether the membrane damage is caused will depend on physical and chemical properties of different particles. The fact that the effects of titanium dioxide on cell membranes were not affected by Al citrate may give some insight to the difference between quartz and titanium dioxide in their surface structure and affinity for ions, such as $-N^+(CH_3)_3$ and Al^{3+} .

Another part of this paper focuses on the anti-injurious effect of Al citrate and its mechanism. In general, the increased membrane fluidity, permeability and negative charge density were declined, but the decreased membrane hydration were enhanced following the addition of Al citrate, so that the function, stability and order structure of cell membranes can be recovered and maintained. The observation by scanning electron microscope convinced us of the antagonistic effect of Al citrate once more.²²

The mechanism is discussed through the compared antagonistic effects of several ways of the administration. It seems that Al citrate will affect membrane-bound water and charge by it self if the addition of it into cell medium without washing, but the its effect of disappeared after the cells were washed.¹¹ These findings suggest that Al citrate combines with certain membranes, even though the combination is not firm and matters little to its effect against quartz. No preventive effect was found in fluidity and permeability experiments of macrophages pretreated with Al citrate. Moreover, Al citrate alone did not influence these properties of macrophage membranes. From these it is considered at least that the preventive effect of Al citrate is not produced by its direct action on cell membranes.

The preventive effects of Al citrate and $AlCl_3$ were examined through the pretreatment of particles. The results show that this pretreatment way can effectively resist membrane damage by quartz. On the other hand, the fact that $AlCl_3$ exhibits

a similar action indicates that the pharmacological effective component of Al citrate is mainly Al itself, which explains why many kinds of soluble Al agents processes a similar effect of treatment for silicosis. Attention should be paid to the potential significance of the special action of Al on quartz in preventive and therapeutic silicosis.

REFERENCES

1. Marks, J. et al: A Study of Dust Toxicity Using a Quantitative Tissue Culture Technique. *Brit. J. Ind. Med.* 13:187 (1956).
2. Viglian, E.C., Penis, B.: An Immunological Approach to Silicosis. *J. Occup. Med.* 1:39 (1959).
3. Allison, A.C. et al: An Examination of the Cytotoxic Effects of Silica on Macrophages. *J. Exp. Med.* 124:141 (1966).
4. Liu, S.J., Zou, S.Q.: The Investigation of the Therapeutic Effect of Aluminium Citrate on the Experimental Silicosis of Rat. *J. Beijing Medical College.* 3:185 (1974).
5. Zhang, S.Q., Li, Y.Z.: *The Third National Symposium on Prevention and Treatment of Aluminium Citrate for Silicosis.* Beijing, China. (1984).
6. Zou, T.T.: In Vitro Study of the Effect of Aluminium Citrate against the Cytotoxicity of Quartz. *Metall. Ind. Hyg.* 6:246 (1982).
7. Parkes, W.R.: *Occupational Lung Disorders.* 2nd Ed, pp 54. London (1982).
8. Liu, Y.N., Lin, K.C.: Infrared and Fluorescence Studies on Membrane-bound Water of Erythrocytes. *Acta Biochem. Biophys.* 4:405 (1984).
9. Cao, C.J.: The Effect of Aluminium Citrate on Permeability of Macrophage Membranes to K^+ Caused by Quartz. *Biochem. Biophys.* 1:39 (1985).
10. Pan, H.Z., et al: The Method in Determination of $Na^+-K^+-ATPase$ Activity of Erythrocyte Membranes. (unpublication) (1982).
11. Cao, C.J.: The Effects of Quartz and Titanium Dioxide on Electrophoretic Mobility of Guinea Pig Alveolus Macrophages. *J. Chin. Ind. Hyg. & Occup. Dis.* 3:137 (1985).
12. Schneider, A.S., et al: Role of Bound Water in Biological Membrane Structure: Fluorescence and Infrared Studies. *J. Super. Molecular Structure.* 10:265 (1979).
13. Koshi, K.: Activation of Acid Phosphatase Activity in Macrophage by Quartz Particles. *Ind. Health.* 3:140 (1965).
14. Beck, E., et al: Effects of Chrysotile and Acid Treated Chrysotile on Macrophage Cultures. *Brit. J. Ind. Med.* 28:179 (1971).
15. Kaw, T.L.: Cytotoxic Action of Quartz Dust on Stimulated and Nonstimulated Peritoneal Macrophages In Vitro. *Exp. Mole. Path.* 38:109 (1983).
16. Shattil, S.J., Cooper, R.A.: Membrane Microviscosity and Human Platelet Function. *Biochim.* 15:4832 (1976).
17. Cooper, R.A.: Abnormalities of Cell-membrane Fluidity in the Pathogenesis of Disease. *New Eng. J. Med.* 297:371 (1977).
18. Cao, C.J.: Investigation of the Effects of Quartz and Aluminium Citrate on Fluidity of Artificial Membranes. *J. Chin. Ind. Hyg. & Occup. Dis.* 3:140 (1983).
19. Clifford, J., et al: *Physical Studies of Biological Membrane.* pp 19, Amsterdam, North Holland (1968).
20. Nash, T., et al: Physico-chemical Properties of Silica in Relation to Its Toxicity. *Nature.* 210:259 (1966).
21. Depass, J., et al: Comparison between Two Hypothesis about the Physicochemical Basis of the Toxicity of Silica. *J. Colloid Interface Sci.* 60:416 (1977).
22. Cao, C.J., et al: Scanning Electron Microscope Studies: I. The Comparison of Phagocytosis of Macrophages Exposure to Quartz and Titanium Dioxide Particles; II. The Effect of Aluminium Citrate on Phagocytosis. (unpublication) (1987).

CHANGES IN COMPENSATION FOR OCCUPATIONAL LUNG DISEASE IN BRITAIN OVER 34 YEARS

T.J.G. PHILLIPS, MB MRCP MFOM

Principal Medical Officer, Department of Health and Social Security, London, England

ABSTRACT

Silicosis was the first occupational lung disease to be made compensatable in Britain by legislation in 1919. This was followed by asbestosis in 1931, byssinosis in 1941 and coalworkers pneumoconiosis (CWP) in 1943. More recent additions were mesothelioma in 1966, occupational asthma in March 1982 and two asbestos related diseases in April 1985. (1) Primary carcinoma of the lung accompanying asbestosis and/or bilateral diffuse pleural thickening. (2) Bilateral diffuse pleural thickening. A claim is entertained if it relates to a prescribed disease. A disease may be prescribed only if it is a risk of occupation, and the occupational link can be established or presumed with reasonable certainty in individual cases.

There has been a steady decline in CWP and silicosis with an increase in asbestos related diseases. Thus there were 325 cases of CWP diagnosed in 1987 compared to 357 in 1986, 402 in 1983, 683 in 1985, 937 in 1966 and 4,449 in 1954. Asbestosis was diagnosed in 247 cases in 1987 compared to 312 in 1986, 199 in 1983, 161 in 1975, 114 in 1966 and 31 in 1954. The age at which these conditions were first diagnosed has also increased. A total of 399 cases of mesothelioma presented in 1987 compared to 441 in 1986, 413 in 1984, 282 in 1980 and 212 in 1977. Occupational asthma was found in 199 subjects in 1987 compared to 166 in 1986 and 183 in 1983. Bilateral diffuse pleural thickening was present in 115 cases in 1987 compared to 111 cases in 1986 and 61 in 1985.

The occupational lung diseases eligible for compensation (or benefit) payable by the state in Britain (prescribed respiratory diseases) include, among other conditions, coalworkers pneumoconiosis (CWP), asbestosis, silicosis, diffuse mesothelioma, byssinosis and occupational asthma. A claim for compensation can only be considered if it relates to a prescribed disease and the person concerned has been employed as an insured person under the state scheme in an occupation prescribed for the disease. A disease may be prescribed if (a) it is a risk of occupation and not a risk common to all and (b) the occupational link in individual cases can be established or presumed with reasonable certainty. A committee of experts, the Industrial Injuries Advisory Council, advises the Secretary of State whether a disease should be prescribed. The prescribed occupations for pneumoconiosis and related conditions are set out in full in the Social Security Act of 1975. The diagnosis of these diseases and the assessment of the resulting disablement is made by doctors with special experience of chest diseases employed by the Department who are stationed at eight centres in various parts of Britain.

In 1897 the first Workmens Compensation Act came into force, which gave workmen the right to compensation for accidents at work. This was funded by employers. It was not until 1919 that provision was made under this Act in respect of disablement or death due to silicosis in certain occupations. Following the report of Merewether and Price to Parliament

in 1930, the asbestos industry (asbestosis) scheme was introduced in 1931, which made compensation available for asbestosis for the first time. The publication in 1942 of a Medical Research Council report on chronic pulmonary disease in coalminers showed that these men were liable to a form of pneumoconiosis which could not be regarded as true silicosis. This led to the passing of the Workmens Compensation Act 1943, which covers all forms of pneumoconiosis, as defined in the Act. The definition adopted was "Fibrosis of the lungs due to silica dust, asbestos dust or other dusts, including the condition of the lungs known as dust reticulation."

The whole scheme has replaced the Industrial Injuries Act in July 1948, which provided state benefit for the first time for all forms of pneumoconiosis in relation to a list of scheduled occupations. These regulations were amended in 1954 to enable unscheduled occupations involving exposure to dust to be covered. In August 1956, primary malignant neoplasm of the pleura or peritoneum (diffuse mesothelioma) was included in the list of prescribed diseases, and in October 1983, the word "malignant" was dropped and the pericardium was added to the pleura and peritoneum. In March 1982, occupational asthma was added to the list of prescribed diseases in relation to the seven agents, i.e. (1) isocyanates, (2) platinum salts, (3) fumes or dusts arising from the use of hardening agents, including epoxy resins, (4) fumes arising from rosin used as a soldering flux, (5) proteolytic enzymes, (6) animal

or insects used for research, education or in laboratories, (7) dusts arising from barley, oats, rye, wheat or maize or to dusts arising from meal or flour made from these substances. Seven more agents were added to this list in September 1986; antibiotics, cimetidine, wood dust, ispaghula, castor bean dust, ipecacuanha, and azodicarbonamide. Two asbestos-related diseases were prescribed in April 1985. (1) Primary carcinoma of the lung where there is accompanying evidence of asbestosis and/or bilateral diffuse pleural thickening; (2) Bilateral diffuse pleural thickening. The latest occupational lung disorder to be prescribed was lung cancer in those who have been in an occupation involving (a) work underground in a tin mine; or (b) exposure to bis(chloromethyl)ether produced during the manufacture of chloromethyl methyl ether; or (c) exposure to zinc chromate, calcium chromate or strontium chromate in their pure forms.

The general pattern over the years has been that of a steady decline in the incidence of coalworkers pneumoconiosis and

silicosis with an increase in asbestos-related diseases. The diseases now tend to present in less severe forms and the average age at diagnosis has increased. Thus the average age of diagnosis in coalworker pneumoconiosis in 1987 was 69 years, compared to 57 years in 1968. These changes are shown in some detail in the accompanying tables. These show that only 325 cases of CWP were diagnosed in 1986 compared to 4,449 in 1954, while asbestosis was diagnosed in 247 cases in 1987 compared to 31 in 1954. 399 cases of mesothelioma presented in 1987 compared to 212 in 1977. Occupational asthma was found in 199 subjects in 1987 compared to 183 in 1983 and bilateral diffuse pleural thickening was present in 115 cases in 1987 compared to 61 in 1985.

These figures do not reflect the true evidence of the condition, as when carcinoma occurs in a known case of asbestosis, it is often financially advantageous to the patient to have this regarded as a complication of asbestosis.

Table I
Newly Diagnosed Cases of Pneumoconiosis (Prescribed Disease D1)
According to Year and Industry (Industrial Injuries Scheme)

INDUSTRY	1954	1960	1966	1972	1975	1978	1981	1983	1985	1986	1987
Coalworkers	4,449	3,279	937	626	683	476	493	402	364	357	325
Asbestos workers	31	29	114	125	161	128	140	199	273	312	247
Other mines and quarries	113	86	57	42	41	54	39	10	7	23	27
Foundry workers	256	99	55	40	31	29	13	19	18	19	19
Steel dressers	106	19	18	11	8	5	3	0	6	2	2
Pottery manufacture	345	50	27	24	24	10	10	14	14	10	18
Refractories	26	16	14	8	9	5	5	5	3	6	3
Other industries	156	76	42	43	24	37	31	21	54	44	34
TOTAL	5,482	3,654	1,264	919	981	744	734	670	739	773	675

Table II
Coalworkers Pneumoconiosis—Newly Diagnosed Cases
Analysed by Age and Year of Diagnosis

	Under 35 yrs	35-44 yrs	45-49 yrs	50-54 yrs	55-59 yrs	60-64 yrs	65 yrs & over	TOTAL
1955	199	677	746	1016	924	804	591	4997
1961	43	345	378	505	604	599	289	2768
1968 (average age 57)	7	76	92	127	161	184	127 (a)	774
1975 (average age 61)	2	22	28	73	131	139	288 (b)	683
1979 (average age 62)	-	12	15	67	144	86	214 (c)	538
1983 (average age 64)	-	9	18	31	88	65	191 (d)	402
1987 (average age 69)	-	3	7	18	17	46	234 (e)	325

- (a) includes 20 aged over 75
- (b) includes 63 aged over 75
- (c) includes 62 aged over 75
- (d) includes 70 aged over 75
- (e) includes 98 aged over 75

Table III
Asbestosis—Newly Diagnosed Cases Analysed
by Age and Year of Diagnosis

	Under 35 yrs	35-44 yrs	45-49 yrs	50-54 yrs	55-59 yrs	60-64 yrs	65 yrs & over	TOTAL
1961	-	5	11	8	5	9	5	43
1968 (average age 55)	1	17	17	28	22	31	14 (a)	130
1975 (average age 58)	-	11	19	25	35	39	32 (b)	161
1979 (average age 59)	-	5	9	22	45	21	21 (c)	123
1983 (average age 61)	-	4	15	30	45	35	70 (d)	199
1987 (average age 63)	-	4	11	17	39	59	117 (e)	247

- (a) include 1 aged over 75
- (b) includes 4 aged over 75
- (c) includes 1 aged over 75
- (d) includes 16 aged over 75
- (e) includes 26 aged over 75

Table IV
Mesothelioma Cases Diagnosed According to Year

1966 - 76	1977	1980	1983	1984	1985	1986	1987
1,109	212	282	312	413	405	441	399

Table V
Occupational Asthma—PD D7
Newly Diagnosed Cases Analysed by Agent and Year of Diagnosis

	1983	1984	1985	1986	1987	TOTAL
ISOCYANATES	74	51	46	48	47	266
PLATINUM SALTS	9	4	9	12	10	44
HARDENING AGENTS	12	14	19	28	18	91
SOLDERING FLUX	24	27	25	20	22	118
PROTEOLYTIC ENZYMES	3	1	6	0	5	15
ANIMALS/INSECTS	7	8	7	12	7	41
FLOUR GRAIN	54	32	54	46	41	227
ANTIBIOTICS	0	0	0	0	30	30
CIMETIDINE	0	0	0	0	0	0
WOOD DUST	0	0	0	0	15	15
ISPAGHULA	0	0	0	0	0	0
CASTOR BEAN DUST	0	0	0	0	0	0
IPECACUANHA	0	0	0	0	0	0
AZODICARBONAMIDE	0	0	0	0	4	4
TOTAL	183	137	166	166	199	851

Table VI

**Lung Cancer Accompanied by Asbestosis or Bilateral Diffuse
Pleural Thickening (Prescribed Disease D8)
Cases Diagnosed According to Year**

1985	1986	1987	TOTAL
8	34	55	97

Table VII

**Bilateral Diffuse Pleural Thickening (Prescribed Disease D9)
Cases Diagnosed According to Year**

1985	1986	1987	TOTAL
61	111	115	287

INTEROBSERVER VARIABILITY USING THE ILO (1980) CLASSIFICATION IN SUBJECTS REFERRED FOR COMPENSATION EVALUATION

GEORGE L. DELCLOS, M.D., M.P.H. • R. Keith Wilson, M.D. • Bernard L. Bradley, M.D.

Baylor College of Medicine and the University of Texas School of Public Health, Houston, Texas, USA

INTRODUCTION

It is estimated that several million persons were occupationally exposed to asbestos between 1940 and the late 1970s.⁶ Accurate identification of those with asbestos-associated conditions leading to premature morbidity and/or mortality is necessary from medical, legal and social-ethical standpoints.

The chest radiograph assumes a central role in the evaluation of different lung dust diseases, particularly in the earlier stages when symptomatology and spirometric changes may be minimal or absent. However, the radiograph is subject to a good deal of both intra and interobserver differences in interpretation. The causes of this variability may be multifactorial, and may include film quality, experience in the interpretation of certain radiographic patterns and prevalence of abnormalities on the chest roentgenogram. We addressed some of these issues in a group of asbestos-exposed subjects referred for compensation evaluation.

STUDY OBJECTIVES

The purposes of this study were:

- a) to assess and quantitate interobserver agreement among experienced readers on certain features of the 1980 ILO Classification of Radiographs of the Pneumoconioses, in a population with a high prevalence of radiographic abnormality;
- b) to assess and quantitate the effect of suboptimal radiographic technique on this interobserver agreement.

MATERIALS AND METHODS

Study Population

The study population was composed of all subjects consecutively referred to our facility for evaluation of possible asbestos-associated conditions between July 1, 1981 and June 30, 1986. All were from Southeast Texas, an area where numerous petrochemical industries and shipyards are located. All were either active or former asbestos end-product users or their immediate family members.

Radiographs

All study subjects underwent a uniform evaluation consisting of a history, physical examination, full resting and exercise pulmonary function testing and chest radiography. Standard 14 × 17 inch radiographs (posteroanterior, lateral and bilateral oblique views) were taken in full inspiration at a

distance of 72 inches, using high-kilovoltage technique at The Methodist Hospital in Houston.

Interpretation of Radiographs

Radiographs were interpreted independently by 3 NIOSH-certified 'B' readers who were unaware of the subjects' identities and histories. Readings were carried out with the radiographs in an unknown order, during three separate batch sessions over a twelve month period, using standard radiographs for comparison. The readers were asked to identify any films that were of less than optimum quality. Profusion scores were based only on the posteroanterior views, and each radiograph was read into one of the 12 ILO minor profusion categories. Later, for purposes of analysis, the profusion scores were grouped into the four major ILO profusion categories, 0 to 3. Pleural readings were based on the posteroanterior views, although the use of the other three views for confirmation was permitted. The pleural endpoints determined in the analysis were: pleural thickening (presence versus absence), width of pleural thickening along the chest wall, pleural calcification (presence versus absence) and extent of pleural calcification, as defined by the 1980 ILO Classification of the Radiographs of the Pneumoconioses.

Statistical Analysis

The degree of interobserver agreement was determined by kappa-type analysis, in order to account for agreement expected on the basis of chance alone. Kappa-type analyses are generally based on the following equation:

$$\bar{k} = \frac{P_o - P_e}{1 - P_e}$$

Where \bar{k} is the kappa statistic, P_o the observed proportion of agreement among the readers, and P_e the proportion of agreement based on chance.

The equations specifically employed in this study were taken from Fleiss, who addresses the calculation of \bar{k} , its standard error (S.E. \bar{k}) and testing of the significance of \bar{k} ; these equations are summarized in Table I.²

Kappa values are greater than 0 only when observed agreement exceeds that attributable to chance alone. The maximum possible value is 1.0. In general, kappa values between 0.81 and 1.0 indicate near perfect agreement; values in the 0.61 to 0.80 range, excellent agreement; 0.41 to 0.60, good agreement; 0.21 to 0.40, fair agreement, and values between 0.00 and 0.20, minimal agreement beyond chance alone.^{2,4}

Table I
Equations Used in Kappa-type Analysis

Calculation of overall kappa statistic:

$$\bar{\kappa} = 1 - \frac{nm^2 - \sum_{i=1}^n \sum_{j=1}^k x_{ij}^2}{nm(m-1) \cdot \sum_{j=1}^k \bar{p}_j \cdot \bar{q}_j}$$

Calculation of the standard error of the overall kappa:

$$\text{S.E.}(\bar{\kappa}) = \frac{\sqrt{2}}{\sum_{j=1}^k \bar{p}_j \cdot \bar{q}_j \sqrt{nm(m-1)}} \sqrt{\left(\sum_{j=1}^k \bar{p}_j \cdot \bar{q}_j\right)^2 - \sum_{j=1}^k \bar{p}_j \cdot \bar{q}_j (\bar{q}_j - \bar{p}_j)}$$

Test of significance:

$$Z = \frac{\bar{\kappa}}{\text{S.E.}(\bar{\kappa})} \quad ; \quad Z \text{ is then referred to tables of the standard normal distribution.}$$

Equations were taken from Fleiss for determination of kappa and its standard error when the number of readings per study subject is constant. (2)

Legend: $\bar{\kappa}$ = kappa; n = no. of study subjects; m = no. of readings per subject; x_{ij} = the number of readings on subject i (i = 1, ...n) into category j (j=1, ...k); \bar{p}_j = overall proportion of readings in category j; $\bar{q}_j = 1 - \bar{p}_j$.

RESULTS

Descriptive Statistics (Table II)

A total of 469 subjects with a complete set of radiographs were identified over the five year period. Of these, 417 gave a history of asbestos exposure; the remaining 52 had, in addition to asbestos exposure, a variable history of silica exposure through sandblasting or spraypainting. The mean age (+/- S.D.) was 55.9 +/- 9.95 years, with an average of 32.6 +/- 9.3 years since onset of first exposure to asbestos and of 27.9 +/- 10.7 years in the trade.

Profusion

The three readers agreed within +/- one minor profusion category of each other on 67% of radiographs. Table III shows the proportion of films read into each major profusion category by the individual readers. Reader 3 classified a higher proportion of films in category 1 than the other two readers; however, when broken down by minor profusion category, the discrepancies were mainly in the 0/0 to 1/0 range (data not shown).

The overall kappa statistic for agreement among the three readers (Table IV) by major profusion category was 0.44 +/- .02 (p < .001). The individual kappas for each category were: category 0, 0.47 +/- .03; category 1, 0.42 +/- .03; category 2, 0.41 +/- .03 and category 3, 0.42 +/- .03, all p < .001.

Pleural Thickening

Table III shows the proportion of radiographs felt to show evidence of pleural thickening, and its width, by individual

reader. Again, Reader 3 classified a greater proportion of films as being consistent with pleural thickening, as compared to the other two readers. The overall kappa statistic (Table IV) for agreement on the presence of pleural thickening was 0.50 +/- .03 (p < .001). Interobserver agreement on the width of pleural thickening, when present, was only fair, with a kappa of 0.35 +/- .02 (p < .001). Individual kappa values by each width category were: category a (1-5 mm in width), 0.25 +/- .03; category b (> 5-10 mm), 0.24 +/- .03, and category c (> 10 mm) 0.38 +/- .03.

Pleural Calcification

The readers showed evidence of excellent agreement on the presence of pleural calcification, with a kappa of 0.62 +/- .03. Agreement on the extent of pleural calcification when present, was good, with a kappa value of 0.48 +/- .02 (p < .001).

Influence of Suboptimal Film Quality

Thirty-seven radiographs (7.9%) were considered to be of less than optimum quality by at least one reader. Separate kappa analysis for profusion and pleural changes was performed on this subgroup in order to assess the influence of film quality. A marked drop in all kappa values was observed. Agreement on profusion (major category) was 0.29 +/- .09 (p < .01). For presence of pleural thickening, kappa was 0.32 +/- .09 (p < .001), and for width of pleural thickening, 0.29 +/- .06 (p < .001). Interobserver agreement on the presence and extent of pleural calcification was likewise much lower, with kappa statistics of 0.40 +/- .09 and 0.27 +/- .08, respectively (p < .001).

Table II
Study Population: Descriptive Statistics

N	469
Asbestos exposure	417
Asbestos & silica exposure	52
Age	55.9 +/- 9.95
Years since onset of first asbestos exposure	32.6 +/- 9.3
Years in trade	27.9 +/- 10.7

(1) Mean +/- S.D.

Table III
Interobserver Agreement: Marginal Proportions

<u>Profusion</u>	<u>ILO Category</u>			
	<u>0</u>	<u>1</u>	<u>2</u>	<u>3</u>
Reader 1	0.62	0.33	0.04	0.01
Reader 2	0.64	0.31	0.04	0.01
Reader 3	0.46	0.50	0.03	0.01

<u>Pleural thickening (width)</u>	<u>ILO Category</u>			
	<u>0</u>	<u>a</u>	<u>b</u>	<u>c</u>
Reader 1	0.44	0.37	0.15	0.04
Reader 2	0.41	0.35	0.14	0.10
Reader 3	0.29	0.38	0.20	0.13

<u>Pleural calcification (extent)</u>	<u>ILO Category</u>			
	<u>0</u>	<u>1</u>	<u>2</u>	<u>3</u>
Reader 1	0.75	0.21	0.04	0.004
Reader 2	0.84	0.08	0.06	0.02
Reader 3	0.84	0.10	0.04	0.02

Table IV
Interobserver Agreement: Kappa Analysis

	<u>\bar{k}</u>	<u>S.E. (\bar{k})</u>	<u>p value</u>
Profusion (major category)	0.44	0.02	<.001
Category 0	0.47	0.03	<.001
Category 1	0.42	0.03	<.001
Category 2	0.41	0.03	<.001
Category 3	0.42	0.03	<.001
Pleural thickening			
Presence versus absence	0.50	0.03	<.001
Width	0.35	0.02	<.001
a (1-5 mm)	0.25	0.03	<.001
b (> 5-10 mm)	0.24	0.03	<.001
c (> 10 mm)	0.38	0.03	<.001
Pleural calcification			
Presence versus absence	0.62	0.03	<.001
Extent	0.48	0.02	<.001

DISCUSSION

The existence of both intra and interobserver variability among readers interpreting radiographs for the presence of pneumoconiotic changes is well recognized.^{5,8,9,10} The creation, and subsequent modifications, of different classification schemes for these interpretations have had several objectives. Among these, to provide a common language with which to describe specific radiographic changes, and to reduce variability and enhance the reliability of these readings. The 1980 ILO Classification is widely used for these purposes.³

Factors felt to influence variability include familiarity with the classification schema, radiographic technique and overall radiograph abnormality rate. Prior studies have shown that interobserver variability is lower among experienced readers.⁹ The effect of suboptimal radiographic technique on interobserver agreement has been somewhat more difficult to measure, with conflicting findings.^{7,8}

Whenever two or more raters independently classify the same set of radiographs, a certain degree of agreement can be expected to result on the basis of chance alone. Chance-based agreement can be calculated,⁷ and depends on the distribution of the radiographs into the different categories (i.e., marginal proportions). Thus, for example, if the abnormality rate is very low, a substantial amount of chance-based agreement can be anticipated; if the abnormality rate is higher, chance-based agreement decreases. Different approaches have been employed to adjust for this phenomenon, such as standardization of observed agreement to a certain abnormality rate.⁹ Kappa-type analysis has been described as a statistical approach to the measurement of interrater agreement, particularly in the area of psychology research.² More recently, at least two studies have appeared where this technique was applied to the assessment of interobserver agreement in the classification of pneumoconiotic changes on chest roentgenograms. Musch et al,⁷ in a study of 1771 active taconite workers, found that the kappa value for three reader agreement on profusion (major category) was 0.26. In their study, the overall abnormality rate was quite low, and a substantial amount of chance-based agreement was felt to be present. The authors also noted that film quality and film age adversely affected kappa. Zoloth et al¹¹ measured agreement among non-specialists and experienced readers in the screening of sheet metal workers for asbestos-associated radiographic changes. Agreement among specialists on the presence of 'asbestosis' ($\bar{k} = 0.38$) was much better than when non-specialists and specialists were compared ($\bar{k} = 0.26$). Agreement on pleural abnormalities was even lower between these two groups ($\bar{k} = 0.14$).

We applied kappa-type analysis to measure interobserver agreement, using the 1980 ILO Classification, in a referred population where the prevalence of radiographic abnormality was likely to be high. The readers were experienced in the use of this classification schema, and assessment of film quality was included. Overall agreement on profusion was good; furthermore, breakdown by each major profusion category showed a fairly uniform level of agreement across all categories. Agreement on the presence of pleural thickening, likewise, was good, and was excellent for detection of pleural calcification. However, concordance on the width of pleural

thickening was only fair ($\bar{k} = 0.35$), particularly in the lower width categories. This contrasted with good agreement on extent of pleural calcification ($\bar{k} = 0.48$). Few studies have addressed interobserver agreement on pleural abnormalities. Rossiter⁹ found that, among 12 readers, the prevalence of pleural thickening varied widely; variation was least for pleural calcification. Zoloth et al,¹¹ as previously noted, found a very poor level of agreement on pleural changes. In our study it is possible that a better level of agreement was found, not only because of the use of experienced readers, but also because they had access to oblique and lateral views for confirmation.

Suboptimal film quality had a marked effect on agreement in this study, with respect to both profusion and pleural changes. Although earlier on this detrimental effect had been difficult to demonstrate,⁸ more recently Musch et al, using kappa analysis, were able to measure it; our findings are consistent with this latter study.⁷

In summary, overall agreement among experienced readers using the 1980 ILO Classification in a referred population appears to be good for profusion and pleural thickening presence, and excellent for the detection of pleural calcification. Interobserver agreement on width of pleural thickening, when present, however, is only modest and highlights an area where further efforts may need to be directed to reduce variability.

REFERENCES

1. Castellan, R.M., Sanderson, W.T., Petersen, M.R.: Prevalence of Radiographic Appearance of Pneumoconiosis in an Unexposed Blue Collar Population. *American Review of Respiratory Disease* 131: 684-686 (1985).
2. Fleiss, J.L.: *Statistical Methods for Rates and Proportions*, 2nd Ed., pp 211-236. John Wiley & Sons, Inc., New York (1981).
3. International Labour Office. Guidelines for the Use of ILO International Classification of Radiographs of the Pneumoconioses Rev. Ed. 1980. Occupational Safety and Health Series. No. 22, International Labour Office, Geneva, 1980.
4. Landis, J.R., Koch, G.G.: The Measurement of Observer Agreement for Categorical Data. *Biometrics* 33:159-174 (1977).
5. McMillan, G.H.G., Rossiter, C.E., Deacon, R.: Comparison of Independent Randomized Reading of Radiographs with Direct Progression Scoring for Assessing Change in Asbestos-related Pulmonary and Pleural Lesions. *British Journal of Industrial Medicine* 39: 60-61 (1982).
6. Murphy, R.L., Becklake, M.R., Brooks, S.M., Gaensler, E.A., Gee, B.L., Goldman, A.M., Kleinerman, J.I., Lewinsohn, H.C., Mitchell, R.S., Utell, M.J., Weill, H.: The Diagnosis of Non-malignant Diseases Related to Asbestos. *American Review of Respiratory Disease*. 134:363-368 (1986).
7. Musch, D.C., Landis, J.R., Higgins, I.T.T., Gilson, J.C., Jones, R.N.: An Application of Kappa-Type Analyses to Interobserver Variation in Classifying Chest Radiographs for Pneumoconiosis. *Statistics in Medicine*. 3:73-83 (1984).
8. Reger, R.B., Morgan, W.K.C.: On the Factors Influencing Consistency in the Radiologic Diagnosis of Pneumoconiosis. *American Review of Respiratory Disease* 102:905-915 (1970).
9. Rossiter, C.E.: Initial Repeatability Trials of the UICC/Cincinnati Classification of the Radiographic Appearances of Pneumoconioses. *British Journal of Industrial Medicine* 29:407-419 (1972).
10. Werner, J.B.: Problems with the Measurement of Radiological Change. *Biological Effects of Mineral Fibres*, pp 571-577. J.C. Wagner, Ed. International Agency for Research on Cancer, IARC Scientific Publications, No. 30, Lyon (1980).
11. Zoloth, S., Michaels, D., Lacher, M., Nagin, D., Drucker, E.: Asbestos Disease Screening by Non-Specialists: Results of an Evaluation. *American Journal of Public Health* 76:1392-1395 (1986).

LEGAL REQUIREMENTS FOR MEDICAL SURVEILLANCE OF ASBESTOS WORKERS IN MALAYSIA, THE USA AND UNDER INTERNATIONAL LAW

KRISHNA G. RAMPAL,* M.B.B.S., M.P.H. • Ilise L. Feitshans,† J.D.

*Department of Community Health, Medical Faculty, National University of Malaysia

†The Johns Hopkins University School of Hygiene and Public Health, Baltimore, Maryland, USA

INTRODUCTION

Worldwide, regulatory actions have consistently required medical surveillance for occupational exposure to asbestos. Regulatory agencies use "medical surveillance" as a method of verifying the effectiveness of engineering controls to prevent work-related disease. In many countries it is also used to detect longitudinal changes in the prevalence and incidence of occupational disease in light of stated regulatory goals. It is therefore an important component of regulatory programs designed to avert and curtail asbestos-related occupational disease.

In 1986, the International Labor Organization (ILO) drafted C.162, "Convention Concerning Safety in the Use of Asbestos"; Malaysia promulgated "Asbestos Process Regulations (1986)" under the Factories and Machinery Act; and the USA revised its "Occupational Safety and Health Act, Occupational Exposure to Asbestos, Tremolite, Anthophyllite and Actinolite, (1986)." One can infer from these and other developments around the world that there is a strong international regulatory trend towards increased protection against occupational exposure to asbestos. This article examines in detail the regulatory requirements for medical surveillance of asbestos workers (excluding worker's compensation) under laws in Malaysia and the USA, using the ILO Convention 162 as an analytical framework. For the purposes of this paper, "medical surveillance" of asbestos workers refers to monitoring of workers' health, as contemplated by C.162, Part IV, Article 21 "Surveillance of the Working Environment and Workers' Health." C.162 Article 21 provides that medical surveillance shall be comprised of five components: (1) medical examinations; (2) monitoring at no cost to workers; (3) information and "individual advice" to workers regarding results of medical examinations; (4) alternative sources of income for those workers for whom asbestos exposure is "medically inadvisable"; (5) a notification system for asbestos-related disease. C.162 allows for expansive protections of exposed workers, through its medical surveillance requirements. Even though many important components of the program are not expressly stated, the key elements of a good program are included within its purview. C.162 therefore is a good blueprint for evaluating medical surveillance programs.

GENERAL BASIS FOR STATUTORY PROTECTIONS

Regardless whether a given regulatory body is a national government or an international organization, standards within

a legal system must not be arbitrary and capricious and must be consistent with the constitutional and practical legal norms within the national or international context. All three of the bodies of law discussed herein fall within the purview of the organization's authority in their respective legal contexts. For example, the ILO Constitution's Preamble considers occupational health is a fundamental human right.¹ By ratifying the ILO Constitution member states grant ILO the authority to promote interaction and coordinated activity between employers, workers and governments and to foster dialogue between less developed and industrialized nations. International standards like C.162 represent the synthesis of international scientific consensus with the perspective of labor, management and government. Despite the weaknesses discussed below, such standards provide a neutral and respected point of reference that can be applied in different political contexts.

Malaysian asbestos regulations have been written with foresight to diminish the likelihood of widespread illness, pursuant to authority in the Factories and Machinery Act 1967 which has jurisdiction to protect the "safety, health and welfare of persons in the workplace."² Section 22 of the Act provides for medical examinations of persons employed in factories where diseases in the Third Schedule (Notifiable Industrial Diseases)³ have occurred or are likely to occur.⁴ Malaysia's asbestos regulations were written pursuant to the authority to promulgate regulations for a safe and healthy work environment in Sec. 56(1).

By contrast, the USA's regulations are an outgrowth of a long, litigious history of asbestos-related disease. The USA's standard for occupational exposure to asbestos,⁵ was adopted pursuant to the "Occupational Safety and Health Act of 1970" ("OSH Act").⁶ OSH Act authorizes the Secretary of Labor to promulgate "occupational safety and health standards" and established the Occupational Safety and Health Administration, (OSHA) to perform this mission. OSHA standards must be "reasonably necessary or appropriate to provide safe or healthful employment or places of employment," under s3(8).⁷ The US Congress' delegation of this authority to OSHA is justified under the "commerce clause"⁸ of the US Constitution.⁹

MEDICAL SURVEILLANCE

Scope of Coverage

C.162 and Recommendation 172 (1986) cover all activities involving exposure of workers to asbestos. However, member

states may exclude particular branches of economic activity or particular undertakings from application of provisions of convention after taking into account the frequency, duration and level of exposure, type of work and conditions at workplace. This provision was written with the intention of creating a flexible framework that could be adjusted to meet the needs of different workplaces in nations of differing levels of development so long as such exemptions are justified. Theoretically, this provision runs the risk of becoming an exception that swallows the rule, since variances may be granted to any number of employees or large sectors of the asbestos industry without jeopardizing the facade of compliance with international standards. This could enable member states to permit various exceptions to the rule, while still in compliance with international norms, although few if any workers would receive protection even though programs exist in concept. This is unlikely, however, given the importance of General Principles in Article 3, (Part II), where ratifying states make a commitment to implement protections through national and local legislation. Unlike older ILO standards, C.162 has no specific exposure indices. This is an advantage because implementation of recent advances are not hindered by outdated "ceilings" or exposure limits.

Malaysia's regulations "apply to all factories in which any asbestos process is used but shall not apply to any building operations or works of engineering construction." The regulations only cover asbestos process—meaning "manufacturing process involving the use, application, removing, mixing or other handling of asbestos material, excluding: 1. cleaning of premises, plant, equipment, furniture or fittings; and 2. asbestos dust dispersed but does not exceed PEL in the breathing air." The PEL is 1 fiber per ml 8 hour TWA.¹⁰ As in C.162, use of crocidolite is banned in the workplace. The Malaysian regulations are an excellent example of comprehensive and substantive provisions for medical care to prevent occupational disease even though their scope is limited to a narrow segment of the asbestos-using portion of the economy.

The USA's federal OSHA regulations cover all occupational exposure to asbestos except in the construction industry, (covered under a separate section of the OSHA standards). This aspect of OSHA standards has been heavily litigated in the last decade, most recently in *Building and Construction Trades Department v. Brock*.¹¹ The court held that OSHA needed to revise its standards in relation to the building trades. Another exception to the regulations concerns employers below the "action level" (0.1 fiber/ml), even though this may not preclude regulation by state and local authorities or environmental protection agencies. This is a significant loophole in health protection; it is one that looms even larger in light of recent initiatives towards increased self-reporting by employers.

Medical Surveillance Requirements

Asbestos exposure is associated with pleural plaques, pleural calcification, pleural effusion,^{12,13} asbestosis,^{14,15} lung cancer,^{16,17} pleural mesothelioma,¹⁸ peritoneal mesothelioma¹⁹ and cancers of the larynx.^{20,21} Good surveillance programs for asbestos exposed individuals seek to diagnose these conditions before they manifest clinically, taking into account the latency period and natural history of disease. They

also screen for existing disease and monitor the occurrence and progress of disease. According to the American Thoracic Society (ATS), the following information is necessary to make a reliable diagnosis: a reliable history of exposure; an appropriate time interval between exposure and detection; and clinical manifestation. Additionally, in cases of asbestosis, diagnostic criteria include: (1) standard chest radiographic evidence with type s, t, u, irregular opacities with profusion of 1/1 of greater classified by the ILO Classification, 1980; (2) a restrictive pattern of lung impairment with forced vital capacity below the lower limit of normal; (3) a diffusing capacity below the lower limit of normal; (4) in bilateral late or pan inspiratory crepitations at the posterior lung bases not cleared by cough.²² C.162 enables competent authorities in member states to authorize and verify the existence of programs that include these key components.

1. Medical Examinations

C.162 provides that member states shall require medical examinations. Member states are free to determine, however, the frequency, (e.g. annual or biennial) place, (e.g. at the worksite, or in a governmental health facility); and extent of such examinations, pursuant to their respective laws. All three laws require pre-placement screening and periodic examinations, (although the length of time between examinations may vary). C.162 uniquely requires medical surveillance after termination of employment.

Malaysia and the USA similarly require that the content of medical examinations include: occupational and smoking history; physical examination; pulmonary function test and a chest radiograph. Of these two sets of regulations, the content of medical examinations in the USA is more clearly defined. A standardized questionnaire for occupational and smoking history administered during the medical examination, is useful for generating epidemiologic information. It also ensures repeatability of results over time and from one physician to another. While Malaysia has no standardized questionnaire, existing model questionnaires developed by the Medical Research Council, and Epidemiology Standardization Project could be modified for Malaysia's use.²³ By contrast, the USA's requirements include use of a standardized respiratory questionnaire, which is readily obtained by reading Appendix D of the OSHA regulations.²⁴

Spirometric measurements taken during pulmonary function testing should be carried out by physicians or specially trained technicians.²⁵ Quality control in pulmonary function testing is important as there is large variability in instrumentation and measuring techniques.²⁶ In Malaysia, there are no approved training programs nor standardized criteria for pulmonary function testing. This is problematic for the implementation of the regulations. Insofar as standardization of spirometry is concerned, criteria by ATS²⁷ and the European Community for Coal and Steel²⁸ could be used. In the USA, technicians are trained to use the ATS criteria in National Institute for Occupational Safety and Health (NIOSH) approved training programs.

Detection of the severity of pneumoconiosis depends on the technical quality of the radiograph and the training and experience of the reader.²⁹ Ideally, films used for medical surveillance for pneumoconiosis should be read by two independent readers and if the readings differ, a third independent reading should be obtained and consensus interpretation obtained.³⁰ In Malaysia, there are no training programs for those physicians who read chest radiographs; and use of ILO Classification System of Radiographs, ("ILO Radiographs") is not required under this law.

According to USA law, chest radiographs shall be read by radiologist, or those with training in reading the ILO Radiographs. Pursuant to Appendix E,³¹ chest roentgenograms "shall be interpreted and classified in accordance with a professionally accepted classification system and recorded on a roentgenographic interpretation form CSD/NIOSH(M) 2.8." This can only be done by: a "B reader"; a board eligible/certified radiologist; or an experienced physician with expertise in pneumoconiosis. The regulations also require all interpreters to have ILO-U/C International Classification of Radiographs of Pneumoconiosis 1980.

Preplacement examinations screen for preexisting disease, fitness to work in asbestos site, and to exclude those not fit. In Malaysia they are required within 30 days from employee commencing work in asbestos area. In the USA such exams are a requisite to assignment. Periodic medical examination monitor for disease and changes in health status of individual. C.162 requires periodic medical examinations, as determined by competent authority in member states. In Malaysia periodic medical examinations are required "at intervals not longer than 2 years"³² while in the USA medical examinations to be made available annually.³³ Although the medical examinations are to be conducted annually in the USA, chest radiographs are carried out every 5 years for all age groups who are examined within 10 years of first exposure. For workers whose exposure began more than 10 years ago, chest radiographs are taken every 5 years if the worker is 15-35 years of age; every 2 years; if worker is 35-45 years of age; and each year for those age 45 or older. All workers must also be examined within 30 days of termination.

2. Cost of medical surveillance

All three of these pieces of legislation agree that medical examinations shall be "free of charge" to the employee.³⁴ C. 162 states that medical examinations take place during working hours when possible.

3. Information provided to workers

Under C.162³⁵ the workers should have access to "individual advice" regarding the results of their medical exams. Since C.162 does not explicitly require full disclosure by the physician, this raises issues of medical ethics if in the physician's professional judgement, full disclosure has a detrimental effect upon the worker's health. But, the absence of a requirement for full

disclosure also has the potential for abuse by employers who direct the physical-employee to withhold information. Malaysian regulations require medical results to be given to the employer and employee upon the employee's request.³⁶ In the USA, employers must make available medical records for examination and copying to affected employees, former employees, designated representatives and the government. Implicit in the requirement that workers obtain information is an underlying concept: that physicians should have access to any or all information relevant to the health status of the worker who is the subject of medical surveillance. Both C.162 and Malaysian regulations do not expressly define the scope of information to be provided to the physician. The OSHA's "Medical Access" regulations clearly require disclosure to workers of any or all relevant information pertaining to their exposure and their medical history.³⁷ In addition, the asbestos regulations require the employer to give the examining physician: relevant OSHA regulations; a description of employees duties as related to exposure; a representative or anticipated exposure level; a description of any personal protective or respiratory equipment; and employees medical records, not otherwise available to the physician.

4. Alternative sources of income

The diagnosis of asbestosis does not mean impairment of lung function or physical disability is necessarily present. Many workers whose conditions are detected by medical surveillance will be capable of continuing their work in other areas of employment, without exposure to asbestos; C.162 therefore requires that workers who might not qualify for workers' compensation or social security disability benefits must be offered other means of maintaining their income.³⁸

5. Notification system

C.162 requires that member states develop a notification system for asbestos related disease.³⁹ Factories and Machinery Act Sec. 32 requires registered medical practitioners attending to or called to visit a patient suffering from a notifiable industrial disease to send a notice to the Chief Inspector and the occupier of the factory. According to the US Regulations the physician is to provide the employer with a written opinion on the employee. The employer must then provide the employee with a copy of the written report within 30 days of receipt. Reportability of diseases in the USA is a subject matter for state, not federal jurisdiction.

CONCLUSION

Given that early detection cannot always alter the course of an exposed worker's prognosis, the validity and purpose of medical surveillance has been questioned. Notwithstanding this view, medical surveillance among asbestos workers represents a fundamental protection that has been codified in international and national asbestos standards and is an extremely useful tool for measuring compliance as well as evidence of disease in cases of torts. C.162 provides a comprehensive medical surveillance program to control occupa-

tional lung disease. While C.162 raises many issues regarding implementation, it provides a sound blueprint for good medical surveillance programs. The national laws reviewed herein are consistent with C.162's conceptual underpinnings and reflect the universality and reasonableness of its provisions. Standing alone, however, medical surveillance cannot be viewed as an alternative to sound work practices, control technology, or environmental monitoring to reduce worker exposure.⁴⁰ The medical surveillance provisions discussed herein therefore must be viewed as but one small component of an overarching, cohesive administrative scheme for inspection, engineering controls, and enforcement of a host of occupational safety and health programs.

The nations used as examples in this paper span the gamut of economic levels, from developing to fully-industrialized. Yet, each recognizes the importance of good medical surveillance, as reflected also in international norms, within the purview of their respective national laws. These regulations are therefore likely to withstand judicial scrutiny and remain enforceable as widely accepted norms in these and other nations, for many years to come.

REFERENCES

1. Preamble to the *ILO Constitution*, [Chapter XIX, *Treaty of Versailles*, 1919].
2. *Factories and Machinery Act 1967*, P.U. (A) 289. Enacted in 1967 as Act 64 of 1967 Revised in 1974 and Published as *Laws of Malaysia Act 139* on 20 June, 1974., (henceforth "Factories and Machinery Act 1967").
3. The Third Schedule concerns a listing of occupational disease but is not a workers' compensation schedule.
4. *Factories and Machinery Act 1967*, Sec. 22.
5. The USA's standard for occupational exposure to asbestos, (29 CFR 1910.1001.), (1986).
6. "Occupational Safety and Health Act of 1970," 29 U.S.C. Sec. 651 et seq. (1970), ("OSH Act"). PL 91-596 (1970).
7. OSH Act s3(8): 29 U.S.C. s652(8).
8. The U.S.A. Constitution, Article I, grants Congress the authority "to regulate commerce with Foreign Nations and among the several States." This power has historically been broadly defined to include many subjects that also affect individuals.
9. U.S.A. Constitution, Article I, Section 8.
10. *Factories and Machinery Act of 1967*, *Factories and Machinery, (Asbestos Process) Regulations*, 1986, Part I, Sec.3.
11. *Building Construction Trades Dept., (AFL-CIO) vs. Brock*, ("Building Trades") consolidated cases No. 86-1359; No. 86-1360; No. 86-1410; No. 86-1411. Decided February 2, 1988. F2d, (Ct. of App., D.C. Cir.) (1988).
12. Churg, A.: Nonneoplastic diseases caused by asbestos. In: Churg, A., Green F.H.Y., eds. *Pathology of Occupational Lung Disease*. New York: Igaku-Shoin Medical Publishers, 1988: 213-278.
13. Becklake, M.R.: Asbestos related diseases, lungs and other organs: Their epidemiology and implications for clinical practice. *Am. Rev. Respir. Dis.* 1976; 114-187.
14. Cooke, W.E.: Fibrosis of the lungs due to inhalation of asbestos dust. *Br. Med. J.* 1924; 147.
15. McDonald, S.: Histology of pulmonary asbestosis. *Br. Med. J.* 1927; 1025-1026.
16. Lynch, K.M., Smith, W.A.: Pulmonary asbestosis III: Carcinoma of lung in asbesto-silicosis. *Am. J. Cancer* 1935; 24:56-64.
17. Doll, R.: Mortality from lung cancer in asbestos workers. *Brit. J. Industr. Med.* 1955; 12:81-86.
18. Wagner, J.C., Sleggs, C.A., Marchand, P.: Diffuse pleural mesothelioma and asbestos exposure in the North Western Cape Province. *Br. J. Ind. Med.* 1960; 17:260.
19. McDonald, A.D., McDonald, J.C.: Epidemiology of malignant mesothelioma. In: Antman, K., Aisner, J., eds. *Asbestos-Related Malignancy*. Orlando: Grune & Stratton, Inc. 1987: 31-56.
20. Newhouse, M.L., Berry, G.: Asbestos and laryngeal carcinoma. *Lancet* 1973; 615.
21. Stell, P.M., McGill, T.: Asbestos and laryngeal carcinoma. *Lancet* 1973; 2:416-417.
22. Murphy, R.L., Becklake, M.R., Brooks, S.M. et al: The Diagnoses of Nonmalignant Diseases Related to Asbestos, Official ATS Statement. *Am. Rev. Respir. Dis.* 1986; 134:363-368.
23. Ferris, B.: Epidemiology standardization project. *Am. Rev. Respir. Dis.* 118(6) 1980.
24. OSH Act 29 USC 651 et seq, regulations pursuant to that act are found in 29 CFR 1910. 1001, Appendix D.
25. Gardner, R.M., Clausen, J.L., Epler, G.R., et al: Pulmonary function laboratory personnel qualifications. Official ATS Statement. *Am. Rev. Respir. Dis.* 1986; 134:623-625.
26. Gardner, R.M., Clausen, J.L., Crapo, R.O., Epler, G.R., Hankinson, J.L., Johnson, Jr., R.L., Plummer, A.L.: Quality assurance in pulmonary function laboratories. Official ATS Statement. *Am. Rev. Respir. Dis.* 1986; 134:625-627.
27. Gardner, R.M., Hankinson, J.L., Clausen, J.L., Crapo, R.O., Johnson, Jr., R.L., Epler, G.R.: Standardization of Spirometry—1987 Update. *Am. Rev. Respir. Dis.* 1987; 136:1285-1298.
28. Quanjer, P.H. ed.: Standardized lung function testing. *Bull. Europ. Physiopath. Resp.* 1983; 19S(5):1-92.
29. Reger, R.B., Morgan, W.K.C.: On the factors influencing consistency in the radiographic diagnosis of pneumoconiosis. *Am. Rev. Respir. Dis.* 1970; 102:905-915.
30. International Labor Office. Occupational Safety and Health Series No 22 (rev) Guidelines for the use of ILO International Classification of Radiographs of Pneumoconiosis, 1980.
31. 29 CFR 1910.1001 Appendix E.
32. *Factories and Machinery Act, (Asbestos Process) Regulations 1986* P.U. (A) 289 Part VI Sec. 13. (2) (b).
33. 29 CFR 1910.1001 Sec. (1)(3). [Medical Surveillance].
34. ILO: C.162 Article 21. Paragraph 2; Malaysia: *Factories and Machinery Act, (Asbestos Process) Regulations 1986* P.U. (A) 289 Part VI Sec. 13. (1). USA: OSHA asbestos regulations 29 CFR 1910.1001 Sec.(1) (1) (ii).
35. C.162 Article 21 Paragraph 3.
36. *Factories and Machinery Act, (Asbestos Process) Regulations 1986* P.U. (A) 289 Part VI Sec. 15.
37. Pursuant to OSH Act Sec. 7(b) and Sec. 6 (b) (7), 29 U.S.C. Secs. 651-678, (1970) OSHA promulgated its "Medical Access Standard," 29 CFR 1910.20 (1980); upheld in *Louisiana Chemical Association v. Bingham*, 657 F2d 777 (5th Cir) (1981).
38. C.162 Article 21, Paragraph 4.
39. C.162 Article 21, Paragraph 5.
40. Boehlecke, B.: Medical monitoring of lung disease in the workplace. In: Gee, J.B.L., ed.: *Occupational Lung Disease*. New York: Churchill Livingstone, 1984:225-240.

APPENDIX I: INTERNATIONAL LABOUR CONFERENCE

Convention 162

CONVENTION CONCERNING SAFETY IN THE USE OF ASBESTOS

PART IV. SURVEILLANCE OF THE WORKING ENVIRONMENT AND WORKERS' HEALTH

Article 20

1. Where it is necessary for the protection of the health of workers, the employer shall measure the concentrations of airborne asbestos dust in workplaces, and shall monitor the exposure of workers to asbestos at intervals and using methods specified by the competent authority.

2. The records of the monitoring of the working environment and of the exposure of workers to asbestos shall be kept for a period prescribed by the competent authority.

3. The workers concerned, their representatives and the inspection services shall have access to these records.

4. The workers or their representatives shall have the right to request the monitoring of the working environment and to appeal to the competent authority concerning the results of the monitoring.

Article 21

1. Workers who are or have been exposed to asbestos shall be provided, in accordance with national law and practice, with such medical examinations as are necessary to supervise their health in relation to the occupational hazard, and to diagnose occupational diseases caused by exposure to asbestos.

2. The monitoring of workers' health in connection with the use of asbestos shall not result in any loss of earnings for them. It shall be free of charge and, as far as possible, shall take place during working hours.

3. Workers shall be informed in an adequate and appropriate manner of the results of their medical examinations and receive individual advice concerning their health in relation to their work.

4. When continued assignment to work involving exposure to asbestos is found to be medically inadvisable, every effort shall be made, consistent with national conditions and practice, to provide the workers concerned with other means of maintaining their income.

5. The competent authority shall develop a system of notification of occupational diseases caused by asbestos.

APPENDIX II: RECOMMENDATION 172
RECOMMENDATION CONCERNING SAFETY IN THE USE OF ASBESTOS
IV. SURVEILLANCE OF THE WORKING ENVIRONMENT
AND WORKERS' HEALTH

29. In cases determined by the competent authority, the employer should make arrangements for systematic surveillance of the concentration of airborne asbestos dust in the workplace and of the duration and level of exposure of workers to asbestos and for the surveillance of the workers' health.

30. (1) The level of exposure of workers to asbestos should be measured or calculated in terms of time-weighted average concentrations for a specific reference period.

(2) The sampling and measurement of the concentration of airborne asbestos dust should be carried out by qualified personnel, using methods approved by the competent authority.

(3) The frequency and extent of sampling and measurement should be related to the level of risk, to changes in the work processes or other relevant circumstances.

(4) In evaluating the risk the competent authority should take into consideration the risk posed by all sizes of asbestos fibres.

31. (1) For the prevention of disease and functional impairment related to exposure to asbestos, all workers assigned to work involving exposure to asbestos should be provided, as appropriate, with –

- (a) a pre-assignment medical examination;
- (b) periodic medical examinations at appropriate intervals;
- (c) other tests and investigations, in particular chest radiographs and lung function tests, which may be necessary to supervise their state of health in relation to the occupational hazard and to identify early indicators of disease caused by asbestos.

(2) The intervals between medical examinations should be determined by the competent authority, taking into account the level of exposure and the workers' state of health in relation to the occupational hazard.

(3) The competent authority should ensure that provision is made, in accordance with national law and practice, for appropriate medical examinations to continue to be available to workers after termination of an assignment involving exposure to asbestos.

(4) The examinations, tests and investigations provided for in subparagraphs (1) and (3) above should be carried out as far as possible in working hours and should entail no cost to the worker.

(5) Where the results of medical tests or investigations reveal clinical or preclinical effects, measures should be taken to prevent or reduce exposure of the workers concerned and to prevent further deterioration of their health.

(6) Results of medical examinations should be used to determine health status with regard to exposure to asbestos and should not be used to discriminate against the worker.

(7) The results of medical examinations should be used to help place the worker in a job which is compatible with the status of his health.

(8) Workers subject to supervision of their health should have–

- (a) the right to confidentiality of personal and medical information;**
- (b) the right to full and detailed explanations of the purposes and results of the supervision;**
- (c) the right to refuse invasive medical procedures which infringe on their corporal integrity.**

32. Workers should be informed in an adequate and appropriate manner, in accordance with national practice, of the results of the medical examinations and receive individual advice concerning their health in relation to their work.

33. When an occupational disease caused by asbestos has been detected by health surveillance, the competent authority should be notified in conformity with national law and practice.

34. When continued assignment to work involving exposure to asbestos is found to be medically inadvisable every effort should be made, consistent with national conditions and practice, to provide the workers concerned with other means of maintaining their income.

35. National laws or regulations should provide for the compensation of workers who contract a disease or develop a functional impairment related to occupational exposure to asbestos, in accordance with the Employment Injury Benefits Convention, 1964.

36. (1) The records of the monitoring of the working environment should be kept for a period of not less than 30 years.

(2) Records of the monitoring of exposure of workers as well as the sections of their medical files relevant to health hazards due to exposure to asbestos and chest radiographs should be kept for a period of not less than 30 years following termination of an assignment involving exposure to asbestos.

37. The workers concerned, their representatives and the inspection services should have access to the records of the monitoring of the working environment.

38. In the case of closure of an undertaking, or after termination of engagement of a worker, records and information kept in accordance with Paragraph 36 above should be deposited in accordance with the directions of the competent authority.

39. In accordance with the Tripartite Declaration of Principles concerning Multinational Enterprises and Social Policy, adopted by the Governing Body of the International Labour Office, a national or multinational enterprise with more than one establishment should be required to provide safety measures relating to the prevention and control of, and protection against, health hazards due to occupational exposure to asbestos, without discrimination, to the workers in all its establishments regardless of the place or country in which they are situated.

V. INFORMATION AND EDUCATION

40. The competent authority should take measures to promote the training and information of all persons concerned with respect to the prevention and control of, and protection against, health hazards due to occupational exposure to asbestos.

41. The competent authority, in consultation with the most representative organisations of employers and workers concerned, should draw up suitable educational guides for employers, workers and others.

COMPENSATING VICTIMS OF OCCUPATIONAL LUNG DISEASE: THE PHYSICIAN'S ROLE IN THE SYSTEM

STEPHEN I. RICHMAN, J.D.

Ceisler/Richmand/Sweet Law Firm, 200 Washington Trust Bldg., Washington, PA, USA

The legal remedies available to victims of occupational lung disease are chiefly of two types: claims for benefits under workers' compensation laws, and suits for damages under the laws of products liability. In workers' compensation law the claimant is required to prove that the employee's death or disability had been caused by his employment, and "disability" usually means that the worker has lost income because he is unable to do his regular job. Under the law of products liability, a supplier of toxic materials is required to warn of dangers involved in handling the materials; the failure to give adequate warning renders the material *unreasonably dangerous* and its supplier liable in damages to the unwarned victim harmed by the material. In both kinds of proceedings, disputed questions of diagnosis, etiology, causation and disability are decided by litigation. These issues involve very complex scientific testimony and a costly battle of experts.¹ The role of the physician as medicolegal consultant and expert witness is: (1) to describe and diagnose all significant pathology; (2) to prove or disprove a causal relationship between the significant pathology and impairment or death; (3) to identify and explain the etiology of the significant pathology; and (4) to evaluate impairment and disability.

THE PHYSICIAN'S ROLE AS MEDICOLEGAL CONSULTANT

Whether clinician or pathologist, the medicolegal consultant must study and evaluate the available evidence of clinical history, occupational history, environmental history, and the history of smoking and other social habits. He should make known his information requirements to the consulting attorney, whose duty it is to use his access to legal processes for gathering facts in order to furnish to the medical consultant all needed data. In his study of the clinical history, the medical consultant should include chest X-ray films, electrocardiographic records, tests of pulmonary function and other relevant laboratory data. If he considers his knowledge of these matters wanting, the medical consultant should candidly acknowledge his limitations to the referring attorney and request additional consultations with appropriate medical specialists.

In performing his investigation, the medical consultant should acquire familiarity with the reported studies which correlate pathologic findings, radiologic appearances and measured pulmonary function. In death cases, the tendency of pathologists to sample the "worst" areas they see at autopsy may mislead the consulting pathologist to a conclusion that the pathology was more severe than was actually the case; but

if there are other physiologic data available, this sampling error can often be identified.¹ Because the histopathologic evaluation may be a more or a less sensitive detector for certain diseases than either pulmonary function or radiology, the need for review of all information, clinical and pathologic, is underscored.¹

The medical consultant should also become informed about the prevalences and etiologic associations of diseases established by epidemiology. In his study of the occupational and environmental history, the medical consultant should identify and comprehend the importance of relevant exposures to toxic substance pollution. For such knowledge, consultation with a chemist, toxicologist or industrial hygienist may be required; and the physician should make the need known to the referring attorney.

Using *all* of the collected information, the consulting physician prepares his opinions as to diagnosis, etiology, causation and disability. In the litigation setting, it is especially important that in expressing diagnoses the medical consultant employ recognized disease nomenclature and standard terminology. As legal counsel, I have frequently witnessed occasions where medical experts ignore or reject the published diagnostic standards and instead employ peculiar nomenclatures and diagnostic criteria in a regrettable litigation tactic calculated to confuse.

In formulating his opinions, the consulting physician must also take into account the *legal* criteria as provided to him by the referring attorney. It is important to realize that the legal criteria and the medical criteria may conflict. The definition of *pneumoconiosis* illustrates the conflict. Whereas medicine's diagnosis requires lung tissue reaction to inhaled dust, Federal black lung law does not; the latter applies the term *pneumoconiosis* to any and all chronic respiratory impairments etiologically related to inhaled coal mine dust.¹

The medical consultant must also comprehend the applicable legal standard of causation, and his opinion must conform to it. When death or disability is due to multiple diseases, of which one creates liability, the question is perplexing. Take, for example, the extremely dyspneic, cigarette smoking insulator whose diagnoses included bronchogenic carcinoma, centrilobular emphysema, asbestosis and severe coronary artery disease with congestive heart failure. Should the medical consultant rank the conditions according to their order of contributing importance; and even quantify by informed estimate the contribution to death or disability made by each? When is the contribution of the single, *compensable* disease

large enough to permit the finding that it had *caused* the death or disability? Depending on the type of legal proceeding and the jurisdiction involved, the legal standard of causation which will be applied for determining whether the contribution by occupational disease had been sufficient, can vary from *any* contribution, to *significant* or *substantial* contribution, to *primary* cause, to requiring that the occupational disease *in and of itself* be the cause of death or disability.¹

After completing all examinations, all testings, and the study of all records and materials, the medical consultant is then able to compose his report. The report should identify the records and materials that had been studied or considered. Findings should be described with measured preciseness and in detail. The opinions expressed may be based on any source, including such hearsay sources as hospital records, reports of other physicians, statements elicited from the disease's victim, and acknowledged scientific treatises; *provided* that the source is inherently reliable and of the kind customarily relied upon by experts in forming their opinions.¹ The report might cite by reference appropriate authorities to support the conclusions reached.

The ultimate conclusions as to diagnosis, etiology, causation or disability should be reached by standard methodological principles² and held with "reasonable medical certainty," and reasonable medical certainty *must* include *logical* deduction from the data available and a comparison with the known literature on the subject.¹ The bases for all opinions and conclusions must be stated in order to demonstrate that they reflect reasoned medical judgment. "An opinion without articulated bases . . . is . . . not very persuasive".³

The report is not confidential and is available to all parties to the proceeding. It may become admitted into evidence and, unsupplemented by oral testimony, constitute the plenary statement of the physician. If the author of the report does give oral testimony at deposition or hearing, any ambiguities or errors in the report will be used to discredit its author's opinions. Therefore, special attention must be assigned to preparation of the report. Requests from the referring attorney for amplification are common and should not be regarded as slighting or offensive. The importance of completeness, accuracy, and unequivocalness in a report intended for use in a legal proceeding is absolutely essential.

THE PHYSICIAN'S ROLE AS EXPERT WITNESS

In workers' compensation and in products liability cases, much of the scientific evidence is greatly beyond the ken of most adjudicators. Only by the testimony of expert witnesses which explains the case can a litigant successfully present its contention with respect to the issues of diagnosis, etiology, causation or disability. The "battle of experts" has in consequence become a standard part of occupational lung disease litigation.

The testimony of the medical consultant, as expert witness, will be presented by oral testimony given under oath. The opposing party will have a full right to cross-examine the expert witness as to all matters covered in direct examination. The setting for testimony may be the court room in the presence of judge and jury; or it may be the physician's own

office by way of stenographic or videotape deposition which is later read or shown to the adjudicator in the court room or at a hearing.

Because a decision in a case is often reached by adopting a particular expert's opinion, it is important that the trier of fact be informed as to the professional qualifications of the expert. According to Belli, a famous trial lawyer, one must impress the jury with and by the witness' credentials. "The more experience the expert has and the more widely recognized he or she is as an authority in the field, the more impressed the members of this jury will be; they will then accord such testimony more weight."¹ Therefore, the expert witness should be prepared to provide, without modesty or exaggeration, an accurate and complete description of his professional qualifications.

In either his preparation for trial or during the presentation of his testimony at trial, the expert witness may desire to review the information upon which his opinions had been based. He is permitted to refer to any matters, including X-ray films and pathologic materials, or even his own report, in order to refresh his memory. However, once referenced, the information becomes subject to the cross-examiner's full right to examine and use it. Occasionally, embarrassment occurs when inspection at trial of the expert's file results in disclosure of forgotten contents which the witness would have preferred to keep private.

References to learned treatises are often invoked in order to corroborate or to impeach the expert's attested opinions. The Federal Rules of Evidence provide: "To the extent called to the attention of an expert witness upon cross-examination or relied upon by him in direct examination, statements contained in published treatises, periodicals, or pamphlets on a subject of history, medicine or other science or art, established as a reliable authority by the testimony or admission of the witness, . . . may be read into evidence . . ."¹

Although the law requires the expert witness to declare that he holds his opinion with a "reasonable degree of medical certainty," this traditional legal formulation may not harmonize with the new formulations of epidemiology. The point is well illustrated where lung cancer is seen in a smoking asbestos worker who had been exposed to other carcinogens. According to Enterline, an opinion about the tumor's etiology *cannot* be stated with *certainty*, because to attribute with *certainty* lung cancer to asbestos would falsely imply that the asbestos exposure somehow blocked the possible effects of all other cancer-causing agents; *but* an opinion *can* be expressed relatively as a mathematic probability for each carcinogenic agent to which the worker had been exposed.¹ At what point medicine's *probability* becomes equivalent to law's reasonable medical certainty is yet to be addressed by the courts. Until it is, the problem will certainly perplex the knowing and conscientious medical expert.

When his opinions are informed, honest and forthright, the physician, who has properly prepared, should not be apprehensive about performing as expert witness and giving oral testimony. Nor should he be timid in his criticism of other physicians when he knows that their opinions are *not* informed, honest or forthright.

The late C. L. Anderson, a pulmonologist at Western Pennsylvania Hospital in Pittsburgh who possessed wide experience as an expert witness, gave some advice which I will pass on: On cross-examination, do not be misled by hypotheticals; stick to what is known medically; be not persuaded by "what might be" or "what could be"; stay with "what is", avoid the fate of the unwary physician led by the cunning cross-examiner down the path to an improbable disease state.¹ Keeping in mind the specific medicolegal issues about which he has been consulted, the medical expert, in giving testimony, should avoid digression, remain relevant, and explicate his points comprehensibly. And be convincing! "However learned and honest the person may be, it must always be remembered that it is not just what the expert knows, it is also what the [referee judge or] jury understands and believes the expert knows."¹

CONCLUSION

The outcome of occupational lung disease litigation is determined more by medical points than by legal points. The attorney who is an experienced and successful litigator of these cases will know generally the medicine of lung disease and

be particularly up on the medical aspects of the case with which he is immediately involved. Because the role of the expert witness is so important to the result, the physician who would be medical consultant and expert witness should anticipate cross-examination by an informed attorney. For the physician who is himself informed about the subject of his testimony, being an expert witness should not create concern because the medical and scientific training of a physician gives him enormous advantage over an adversary trained in the law.

The physician who becomes a medicolegal consultant in a litigated case of occupational lung disease enters into a very topical, socially sensitive and intellectually stimulating professional activity.

REFERENCES

1. Richman, S.I., Legal Aspects For The Pathologist. In: *Pathology Of Occupational Lung Disease*; 1st Ed., pp. 369-383. Churg, A. and Green, F.H.Y., Eds. Igaku-Shoin, New York-Tokyo (1988).
2. Gots, R.E.: Medical Causation and Expert Testimony. *Reg. Tox. & Pharm.* 6:95-102 (1984).
3. Malone, D.M.: How To Make Expert Witnesses Credible. *Trial*; April, 1988: 40-49.

PRODUCT STEWARDSHIP OR BANS? ASBESTOS IN THE THIRD WORLD

BARRY I. CASTLEMAN, ScD

Environmental Consultant, 1722 Linden Avenue, Baltimore, MD, USA

In the technological development of nations, it has been widely accepted that each country would do well to choose "appropriate technology" based on its resources, its people and their needs. Public health impacts of some technologies render them undesirable for Third World country development. Let us consider asbestos.

No one would urge that developing countries today should build plants to make asbestos thermal insulation. Asbestos has been replaced by wood pulp, fibrous glass, and other materials to make insulation products far less deadly than the asbestos insulations used in the past. Thermal insulation reinforced with asbestos is an example of *discredited technology* because of its severe, unavoidable hazards and the availability of safer alternatives. The most recent manufacture of this product I know of was in 1980; however, it may still be made by producers in Thailand and/or India.

Industry Theory: Controlled Use Exists and Is Becoming Universal

The international asbestos industry has claimed for decades that asbestos can be used safely and that it should be used in Third World development. Corrugated asbestos-cement roofing is used worldwide, and together with other asbestos-cement sheet and pipe products accounts for over 80 percent of asbestos use. Increased use of asbestos in developing countries has offset tremendous market losses in the industrial nations over the last 10 years. Quarterly publications of the Asbestos Institute in Quebec describe aggressive sales efforts in Asia, Africa, and Latin America.

The International Labor Office has published a "Code of Practice" enumerating very basic safeguards that should be used in work with asbestos.¹ Some countries have regulations that apply to industries where asbestos hazards exist. The issuance of control instruments as published documents, however, never has and never will assure that the "mandated" controls are in fact applied. The gulf between what is advertised as "controlled use of asbestos" and the reality of manufacturing and construction work with asbestos is greatest in the poor countries whose use of asbestos is on the rise.

Widespread Uncontrolled Use in Developing Countries

The chief of Brazil's environmental protection agency wrote in 1986 that the labor authorities in charge of worker protection did "poor work" and were "very ineffective."² As of 1986, this official wrote that, "we don't make any (power

tools with exhaust ventilation) in Brazil, and it is difficult to import them."³ It seems highly unlikely that portable saws with exhaust ventilation and dust capture are being used by construction workers handling asbestos-cement products in countries like Brazil. When that country's authorities began to inquire about health risks in asbestos manufacturing operations in 1980, the government people depended upon companies visited to provide and demonstrate the use of standard air monitoring equipment. As of 1986, the official workplace exposure limit for asbestos in Brazil was 4 fibers/cc, twenty times as high as the limit in the U.S.

Uncontrolled use of asbestos has been the norm in many countries, even in recent years. Mexican researchers found severe asbestosis in workers employed spraying asbestos; workers spraying asbestos were monitored as having exposures of 54 fibers/cc in 1982.⁴ Investigations in India showed complete disregard for worker health by affiliates of U.S. and U.K. multinational corporations making asbestos products.^{5,6} In one Indian plant, where I have been told asbestos-cement pipe was sawed without local exhaust ventilation, government hygienists measured exposures of 216-418 fibers/cc.⁷

If the asbestos industry is taking concerted action to implement "controlled" use of asbestos today, it represents a complete reversal of recent practices. In 1977, Canadian asbestos mining firms arranged to delete warning labelling about the cancer hazard of asbestos, opting instead to accept written releases of liability from a distributor in Japan.⁸ Similarly, 1978 minutes of the Asbestos International Association reveal an international conspiracy to proceed as slowly as possible, country by country, using the weakest possible warning labels "in fear of a possible influence on sales."^{8,9}

Given the historic lack of both industry product stewardship and controlled asbestos exposures, especially in the vulnerable developing countries, the operative question is: *Will* asbestos hazards be controlled? (not: *Can* asbestos hazards be controlled?) The burden is on the asbestos industry to demonstrate that it is practical to routinely use asbestos in a thoroughly controlled way in developing countries.

The record to date suggests that it is unreasonable to expect that asbestos hazards will be controlled in the developing countries. Industry spokesmen acknowledge that, even now, construction contractors in the U.S. sometimes use abrasive disc saws to cut asbestos-cement pipe—despite advice against the practice by the A-C Pipe Producers Association and the existence of applicable OSHA standards since 1972. Similar problems have been reported with the use of asbestos-cement sheet in U.S. construction work.¹⁰

How then can we expect Third World manufacturers of asbestos products and construction contractors to take on the cost of extraordinary control measures, when there typically isn't even pressure from industry or government authorities to do so? Where is the infrastructure of prevention (information, regulation, and compensation) in Third World countries? And why should developing countries submit to the likelihood of asbestos contamination and disease, when safer alternatives exist that will not warrant the unprecedented commitment of scarce public health resources?

Developing countries may also wish to consider another form of "pollution" that has frequently come along with the growth of an indigenous asbestos industry. This is the corruption of the fledgling professions of industrial medicine and hygiene, as pressures are brought to bear on health professionals in industry, government and academia to learn the "industry line" and downplay concerns about workplace and environmental exposure to asbestos. This impact on a vital sector of a society in development may pave the way for subsequent public health abuses by other industries. Again one must wonder, why should a developing country want to accept the externalized costs of a growing asbestos industry, given the alternatives available in 1988?

Asbestos Substitutes

In the 1980s, an increasing array of asbestos-free products has become commercially available. Asbestos-containing corrugated and flat cement sheeting, valve and pump packings, roofing felts, pipeline wrap, and vinyl flooring are no longer even made in the United States. In Europe, the Swiss Eternit Group (SEG) has agreed to eliminate asbestos in fiber-cement sheet products by 1990 in Germany and Switzerland, in favor of polyolefin fiber-cement sheet. SEG is experimenting with dozens of plant fibers and has already been able to replace asbestos with cellulose and wood fiber substitutes in Costa Rica and other Latin American countries.¹¹ The asbestos-free products carry warranties equal to those of the predecessor asbestos products. In Australia and Malaysia, James Hardie and its affiliates are making cement sheet products reinforced with wood pulp instead of asbestos.

This is progress indeed, when one considers that exposures from sawing asbestos-cement sheet without dust controls have been reported as over 100 fibers/cc.¹² It is also relevant that in many countries people catch water running off their roofs for drinking and cooking. EPA researchers have reported that "asbestos fiber concentrations over 500 million fibers per liter have been found in cistern drinking waters which use asbestos-cement roofing tiles to collect water."¹³ It would be a relief if people had this burden of wood, coconut, or banana plant materials instead of asbestos in their drinking water.

The Role of the Canadian Government in Promoting Asbestos Use

When the U.S. Environmental Protection Agency proposed to ban asbestos, the Canadian government, representing both private and state-owned asbestos mines, applied considerable pressure to oppose the ban.¹⁴ An article in the British magazine *The Economist* created a furor, for it suggested that

Canada had become "a sort of merchant of death by unloading its asbestos on unsophisticated Third World clients who may not be aware of its dangers."^{14,15} Canada's Energy, Mines and Resources Minister Marcel Masse was quoted as responding to the above article by writing, "(t)he risk can be managed anywhere. This includes the Third World, where governments are more aware of the risks and more capable of controlling them than your correspondent is willing to credit."¹⁵ The *Toronto Star* went on to describe a \$30 million campaign of federal and Quebec governments to "try to drag asbestos out of the doghouse."¹⁵

The Asbestos Institute, which is partly supported by Canadian taxpayers, also worries that EPA's proposed asbestos ban will impede the promotion of asbestos in countries which have little or no experience, let alone resources, in controlling industrial cancer threats. The Institute is a joint venture of the asbestos mining industry and the government, "to maximize the use of existing resources in a concerted effort to defend and promote the safe use of asbestos on a global scale." It claims to be "dedicated to promoting the proper use of asbestos."¹⁶

Canadian physician David Bates has called for the establishment of an independent commission ("recruited neither from industry nor from government employees") to monitor certain indicators of product stewardship in the export of Canadian asbestos and report annually to the public.¹⁷ An appropriate topic for such an oversight panel would be the publication of lies like this by Asbestos Institute President Claude Forget: "In (Selikoff's) study of American insulation workers, asbestosis victims did not only inhale white asbestos as you state but were exposed to *mostly amosite asbestos*."¹⁸ Canada's independent asbestos oversight panel, if it is ever set up, might also want to monitor the intimidation and vilification of scientists at conferences where the hazards of asbestos are discussed. For example there is this by the Asbestos Institute Director of the Health and Environment Division, Jacques Dunnigan, at an asbestos conference in Mexico: "It is very hard for me to abstain from expressing my feeling that what we have just heard is standard, usual, ad nauseum repeated practice of some people at Mt. Sinai."¹⁹

Dr. Bates also called on the government of Canada to provide as much money for research into asbestos' health effects as is released for promotion of the industry. This balance, along with the creation of the oversight commission "would help to reassure average Canadians that they could not be accused of simply cynical exploitation of other people's ignorance," he concluded.¹⁷ It is unworthy for the Canadian people to be represented by government officials who would rather sell ever more asbestos than plan for an asbestos-free future.

The Soviet Union's performance as a major exporter of asbestos fiber and technology is also worthy of scrutiny from a health standpoint. Reliable information on this would be most welcome, whether from the USSR, Canada, or other sources.

CONCLUSION

The eventual elimination of asbestos in favor of safer (and in

some cases essentially harmless) materials is of great public health importance. The continued lack of product stewardship by companies and countries mining asbestos, in the interim, constitutes a formidable health threat. It can only be hoped that this industry will see that its credibility and near-term survival depend upon worldwide implementation of unprecedented controls. Without this demonstration that asbestos will be used with stringent safeguards, the industry is sure to suffer rapid declines as social opposition mounts. Anyone who doubts the swiftness with which such events can move should note West Africa's revulsion at being used as a dumping ground for hazardous wastes from the U.S. and Europe.

My own experience with the asbestos industry leads to the conclusion that the only way to assure that asbestos will stop killing people needlessly is to ban it. This approach, which is being taken in Sweden and the United States, is even more attractive in developing countries where stringent regulation is not really a viable alternative to a ban.

REFERENCES

1. Atherley, G. *et al.*: *Safety in the Use of Asbestos*. International Labor Office, Geneva (1984).
2. Noguiera-Neto, P.: letter to B. Castleman (Feb. 6, 1986).
3. Noguiera-Neto, P.: letter to B. Castleman (Mar. 12, 1986).
4. Mendes Vargas, M.M., Maldonado Torres, L.: Aplicacion de Asbesto por Aspersión y Neumoconiosis muy Incapacitante. *Revista Med.* 20: 73-77 (1982).
5. Castleman, B.I.: Double Standards: Asbestos in India. *New Scientist* 89: 22-23 (1981).
6. Castleman, B.I., Vera Vera, M.J.: Impending Proliferation of Asbestos. *Internat. J. Health Serv.* 10:389-403 (1980).
7. *Asbestos: the Dust that Kills*. Centre for Education and Documentation (Bombay), p. 22 (1983).
8. Castleman, B.I.: *Asbestos: Medical and Legal Aspects*. 2nd Ed., pp. 636-645, Prentice-Hall Law & Business, Clifton NJ (1986).
9. Asbestos International Association: 8th Exec. Committee Mtg., Agenda Item 6: Labelling (July 7, 1978).
10. Harless, K.W., Watanabe, S., Renzetti, A.D.: The Acute Effects of Chrysotile Asbestos on Lung Function. *Env. Res.* 16:360-72 (1978).
11. Comments of the Swiss Eternit Group on the EPA's Notice of Proposed Rulemaking on Asbestos, Washington (June 28, 1986).
12. Cross, A.: Practical Methods for the Protection of Men Working with Asbestos Materials in Shipyards. *Safety and Health in Shipbuilding and Ship Repairing*, pp 93-101. International Labor Office, Geneva (1972).
13. Millette, J.R. *et al.*: The Need to Control Asbestos Fibers in Potable Water Supply Systems. *Sci. Tot. Env.* 18:91-102 (1981).
14. Canadian Asbestos/Export and Die? *The Economist*. pp 82-83 (Sept. 26, 1987).
15. Cahill, J.: A \$30 Million Campaign Aims to Take the Curse Off Asbestos. *Toronto Star* (Mar. 7, 1988).
16. *Asbestos*. Vol. 1 (No. 1). The Asbestos Institute, Quebec (1985).
17. Bates, D.V.: Asbestos: Promotion or Prohibition? *Can. Med. Assoc. J.* 136:107-109 (1987).
18. Forget, C.: Dusty Reply. *The Economist*. p 8 (Dec. 12, 1987).
19. *Proceedings Meeting on Asbestos and Health in Latin America*, pp 74-75. M. Mitastein, Ed. Pan American Health Org., Mexico City (1987).

VALUE OF SCREENING SPIROMETRY IN EPIDEMIOLOGIC STUDIES OF PNEUMOCONIOSIS

G. W. FRANK,* M.D. • P. Harbert†

*Department of Medicine, Veterans Administration Medical Center, Los Angeles, California, USA

†Occupational Medicine Branch, Pulmonary Division, Department of Medicine, University of California, Los Angeles, California, USA

ABSTRACT

Pneumoconioses typically cause a restrictive ventilatory defect with low Total Lung Capacity (TLC). Measurement of TLC requires elaborate equipment, is labor-intensive and time-consuming. It is seldom available in industrial settings or epidemiologic field studies. In contrast, portable spirometry is readily and cheaply done. We sought to determine the value of spirometry in predicting a low TLC and its usefulness in screening for restrictive ventilatory defects. As such, the use of spirometry could avoid unnecessary and costly testing of normal individuals. TLC values for an occupationally referred population of 687 shipyard workers (O) and a clinically referred population of 565 patients at a large Veterans Hospital (C) were compared with a spirometric index. This index was derived from the subject's Forced Vital Capacity (FVC) and the ratio between the One-Second Forced Expiratory Volume and the Forced Vital Capacity (FEV_{1_1}/FVC). There was excellent correlation ($p < 0.001$) between TLC and the index, with $r = 0.66$ in (O) and $r = 0.69$ in (C). The index discriminated an abnormally low TLC, i.e., $< 80\%$ predicted, with sensitivities of 88% (O) and 70% (C). Specificities were 79% (O) and 82% (C). Overall concordance values were 80% (O) and 78% (C). Because the index identified the majority of subjects with normal or high TLC, its use in screening for restrictive ventilatory defects could obviate a large number of unnecessary lung volume determinations. Spirometry could thus be very useful in epidemiologic field studies of pneumoconioses.

No Paper provided.

PNEUMOCONIOSIS OF DELAYED APPARITION: LARGE SCALED SCREENING IN A POPULATION OF RETIRED COAL MINERS OF THE NORTHERN COAL FIELDS OF FRANCE

P. FRANCOIS • J.M. Prevost • G. Courtois • A. Mas

Charbonnages de France

The coalworker's pneumoconiosis may appear a long time after the exposure to nocive dust has ceased. This is a well established fact. What we don't know exactly is the frequency of such forms of pneumoconiosis of long delayed apparition.

Figure 1. The number of new cases detected among ex-miners increases from year to year; since 1980, it exceeds the number of the cases diagnosed in the population of the active miners.

According to the French legal prescriptions every coalminer in activity is offered a yearly chest X-ray; therefore the endemy of pneumoconiosis is precisely known among the active population. Such a yearly X-ray follow-up is by no means compulsory for the ex-miners, which makes an exact evaluation of the prevalence of the professional disease among the retired miners impossible. However the French Ministry of Health has made recommendations so that an X-ray control may be offered to the miners who have been exposed to nocive dusts of silica, asbestos and iron. In that legal context in 1983, under the direction of Dr. Amoudru, past Chief-Physician of the French Coal Mines, we initiated a large scaled screening among the ex-miners of the coalfield of the North of France.

METHODS

The medical Centre of Bruay en Artois was selected as an experimental base for a screening to be carried out from 1983 to 1986.

The Aims of Such a Screening Campaign

1. Particular epidemiologic interest attached to such a large inquiry among miners and ex-miners;
2. For some cases opportunity to start a regular survey or a treatment;
3. Possible medico-legal implications: certification and compensation of new cases.

Criteria of Selection

The ex-miners were entered into the study on the basis of the following criteria:

1. Absence of any radiological evidence of pneumoconiosis at the time of the retirement;

2. Duration of the dust exposure equal or superior to 5 years;
3. Cessation of any exposure since at least 3 years, without any consideration of age.

Responses to the Proposition of a Medical Check-up—Figure 2

3624 invitations were issued. 3070 ex-miners participated (85% of the total population). That high percentage of participation may be partly explained by the perspective of a possible certification; it is also the result of the prealable campaign of information addressed to the ex-workers and their family doctors.

Absenteeism represents only 15% of the contacted population. Figure 2 shows the main reasons of that absenteeism: illness among the older ones, indifference of some of the younger ones.

RESULTS

The reading of 3070 radiographs allowed us to detect not only new cases of pneumoconiosis but also other thoracic diseases which required the following complementary explorations:

- 1056 clinical check-ups
- 944 explorations of the respiratory function
- 72 blood gas analysis
- 1056 electrocardiograms
- 223 sputum bacteriological analysis

The 3070 read chest X-rays revealed:

- 1463 subnormal radiographs
- 514 opacities sequelae of prior diseases
- 315 non pneumoconiotic thoracic affections
- 741 new cases of characterized pneumoconiosis

Subnormal Radiographs: (48%)

Strictly speaking we didn't find any absolutely normal X-ray, which is by no means surprising if we consider the average age and the professional anammesis of the studied population.

The subnormal X-rays consisted of: either an increase of linear shadows of the lungs; small calfications, sequelae of tuberculosis, or a certain degree of fibrosis isolated or associated

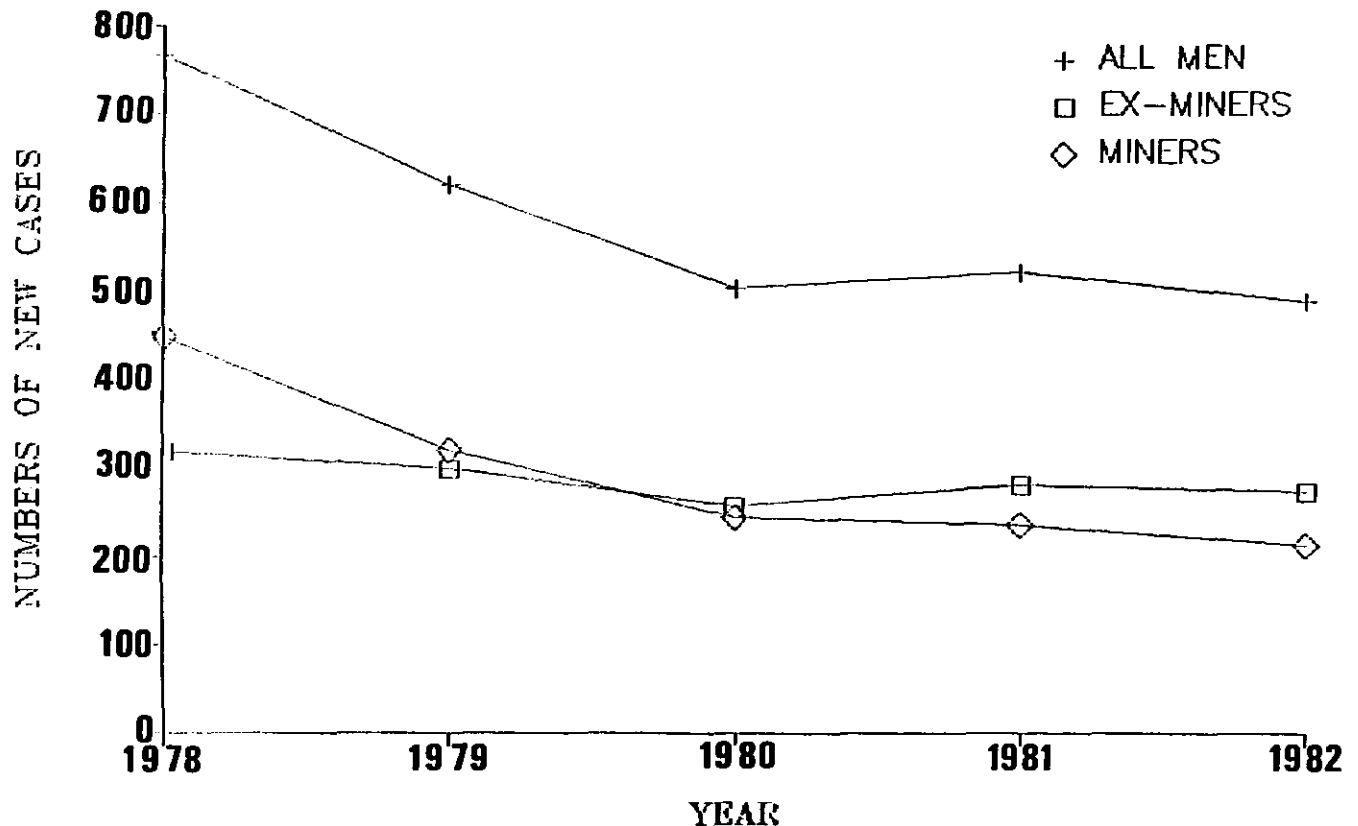

Figure 1. Pneumoconiosis: new diagnoses, northern coal fields of France.

to some fine round opacities.

These data may raise some difficulties of interpretation when dealing with aged people. Is pulmonary fibrosis induced by chronic bronchitis, heavy smoking habits, by the long past of dust exposure, or by an intrication of these various factors?

Opacities Sequelae of Prior-diseases (17%)

1. Sequelae of tuberculosis (184 cases)

In 25% of these cases considerable mutilations were observed from therapeutic procedures anterior to the era of the antibiotics (artificial pneumothorax, lobectomy, thoracoplasty...) with severe failure of the respiratory function in some cases. In the other cases lesser lesions were observed making the diagnosis somehow difficult when associated with some fine opacities.

2. Sequelae of pleural affections: 308 cases

3. Sequelae of broncho-pneumonic diseases and thoracic traumas: 36 cases.

Evolutionary Non Pneumoconiotic Thoracic Diseases: (11%)

- tuberculosis (5 cases)
- cardio vascular affections (174 cases)
- scleroemphysema (110 cases)
- aspergilloma (1 case)
- lung-carcinomas (16 cases)

Primary cancer of the lung of epidermoid type (8 cases), of anaplastic type (3 cases); adenocarcinoma (1 case).

Secondary cancers of the lung (4 cases).

Table I shows that we found 741 new cases of pneumoconiosis, which represents 24% of the examined population.

1. Percentages of new diagnosis by age groups (Figure 3): The percentage is above the average for the groups of age 50 to 54 and 55 to 59. The rate of diagnosis notably decreases from the age of 70.
2. Percentage of new diagnosis in relation with the duration of the dust exposure. On Figure 4, it appears that

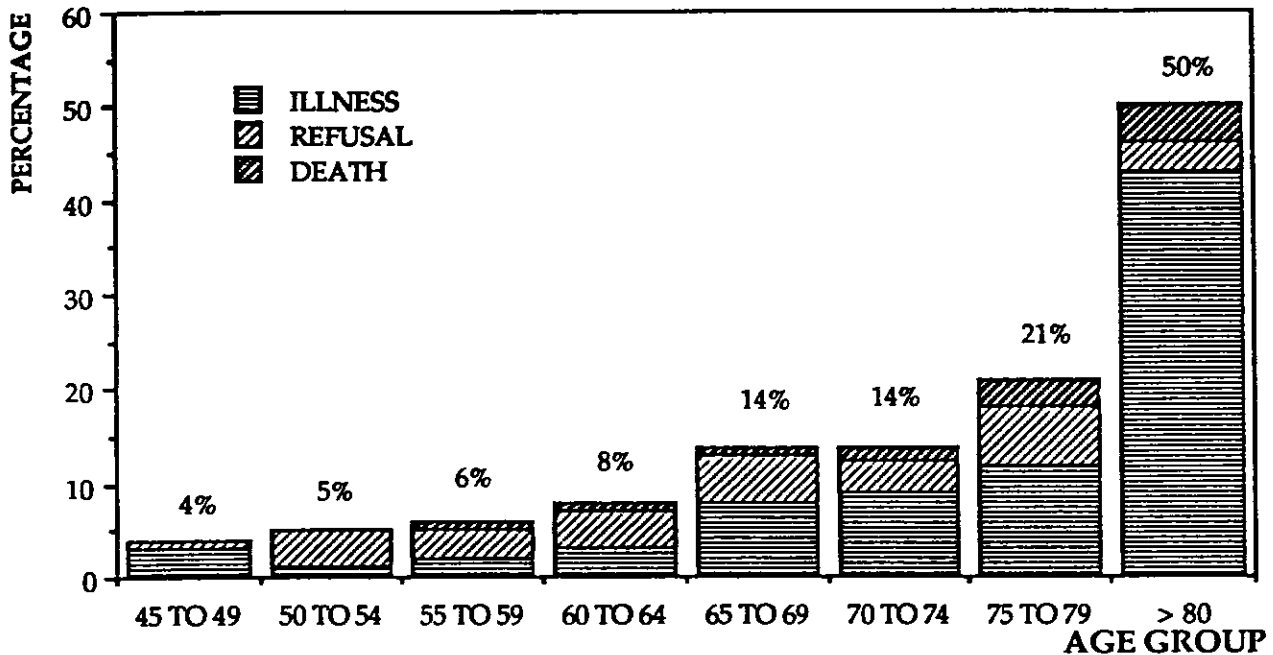

Figure 2. Percentage of non participation in each invited age group.

pneumoconiosis is rarely diagnosed when the dust exposure has been less than 10 years in duration.

3. Smoking habits and delayed cases of pneumoconiosis. Among the 741 new cases we found:

- 237 non-smokers (32%);
- 90 ex-smokers (12%);
- 414 smokers (56%).

We note that two thirds of the new cases concern smokers or ex-smokers, a proportion of smoking habits roughly equal to that of the general male population.

4. The reading of the 741 radiographs of new cases according to the I.L.O. classification of 1980 (Table II). We used the complete classification for the parenchymal opacities, the short one for the pleural changes.

- a. Parenchymal abnormalities consistent with pneumoconiosis. It must be emphasized that interpretation appears often difficult when dealing with aged miners.
- b. Small opacities: as for their profusion in most of cases there are classified category 1.
- c. With regard to their shape and size: p and q, when predominant, represent 98% of the cases.
- d. The irregular opacities (s, t, u) more often seen among the older miners, are, as a rule, associated with round opacities.

The large opacities account for 10% of the new cases. Six out of the 72 cases required long course oxygenotherapy after

blood analysis had been performed. All cases represented a dust exposure superior to 20 years.

Other radiological data recorded: 53 Ax (coalescence of small opacities), 51 em (emphysema) 5 es (egg shell), 50 tb (sequelae of tuberculosis), 46 co (abnormality of the heart silhouette), 22 hi (hilar enlargement), 1 di (distortion of the intra-thoracic organs). Pleural thickening (Pt) was noted only in 13% of cases, such a change being relatively uncommon in coalminer's pneumoconiosis.

To sum up, using the short classification, we found the following repartition:

- a. category 1 (69% of the 741 new cases);
- b. category 2 (21%)
- c. progressive massive fibrosis (PMF) 10%.

Table I
Pneumoconiosis

AMONG 3070 CHEST X RAYS

NEW CASES OF PNEUMOCONIOSIS : 741

24 % OF THE EXAMINED POPULATION

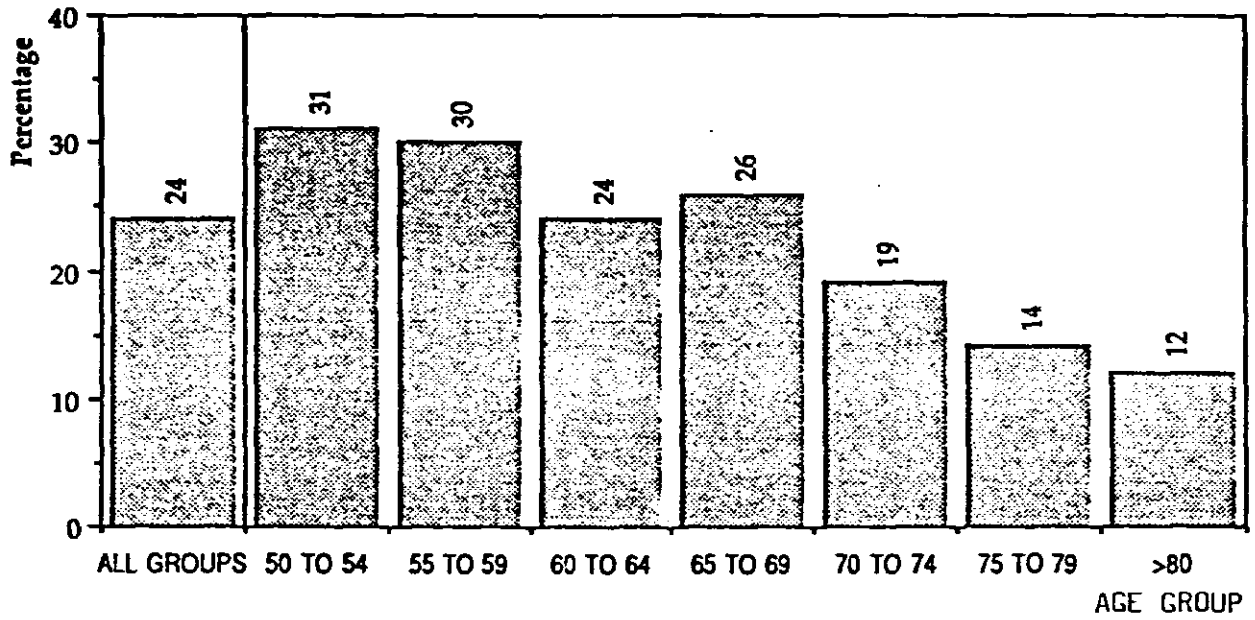

Figure 3. Percentage of new diagnosis by age group.

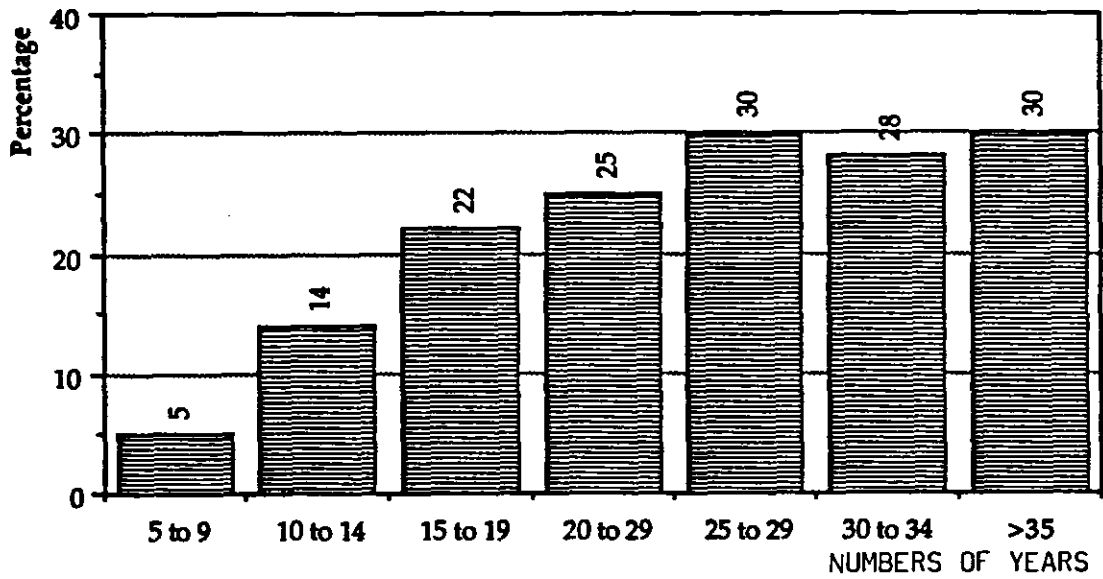

Figure 4. Percentages of new diagnosis in terms of dust-exposure duration.

Table II
 New Cases of Pneumoconiosis: 741
 The Reading of the Radiographs According to the
 ILO Classification 1980

SMALL OPACITIES

PROFUSION	1/1	1/2	2/1	2/2	2/3	3/2	3/3	3 +
NUMBER OF CASES	279	256	107	57	22	14	3	3

SHAPE AND SIZE OF PREDOMINANT OPACITIES	P	Q	R	S - T U
NUMBER OF CASES	75	618	33	15

LARGE OPACITIES

SHADOWS	A	B	C	ALL SHADOWS
NUMBER OF CASES	48	23	1	72

OTHER SYMBOLS

	AX	EM	ES	PT	TB	CO	HI	DI
NUMBER OF CASES	53	51	5	99	50	46	22	1



As an illustration we here present two cases of evident delayed development of pneumoconiosis:

Case No. 1. This 76 year old miner retired 26 years ago after 32 years of exposure to dust. You can see on the left a sub-normal radiograph at the time he ceased his work, on the right the radiograph taken in 1983 showing evidence of pneumoconiosis.

Case No. 2. This 66 year old ex-miner, retired 24 years ago after 25 years of dust exposure, with no evidence of pneumoconiosis on X-ray; in 1983, pneumoconiosis is obvious on the radiograph.

From our experience, we should like to emphasize the following points:

1. When dealing with aged ex-miners a good quality of the radiograph as well as an experienced reader physician are equally required.
2. Chest X-ray should be systematically made at the time of retirement to allow a better further evaluation of a delayed pneumoconiosis.
3. At the time of the screening some data of the personal medical work file, former diseases and psychological status particularly, should be taken into consideration in order to foresee some peculiar reactions after a long delayed pneumoconiosis has been diagnosed. In some cases, a supportive psychotherapy may be indicated. As a converse reaction, a 90 year old ex-miner, with a good

sense of humour, once declared that from now on with the money of compensation, he could afford a call girl!

CONCLUSION

As a rule our ex-miners have appreciated being offered the possibility of such a post-professional check-up performed by the physicians of the familiar medical center of their coal mine.

From a medical view point that large scaled screening campaign is judged positive since it led to the diagnosis of some non-professional affections in addition to an appreciable number of cases of long delayed pneumoconiosis.

Most of those long delayed pneumoconiosis are radiologically characterized by small opacities of profusion 1 and 2.

The opportunity of such screening campaign may be questionable when dust exposure has lasted less than 10 years or when dealing with old ex-miners over the age of 70.

Finally, the experience of that large scale screening has comforted us in the opinion that the post professional survey appears more and more founded in our industry. Coal miner's pneumoconiosis, owing to a more efficient technological and medical prevention has become nowadays a disease of delayed apparition and that epidemiological evolution all the more justifies the post professional survey of our coal miners. Following the French governmental recommendations in that matter, the medical service of our coal mines gets now more and more engaged in the working up of an adapted post-professional medical follow-up for all our ex-miners.



PREVALENCE OF SILICOSIS AMONG CERAMIC INDUSTRIES WORKERS IN THE CITY OF PEDREIRA, BRAZIL

JOSÉ INACIO DE OLIVEIRA, et al.

DMPS/ASO. FCM/UNICAMP—Campinas, Brazil

ABSTRACT

Due to the onset of several cases of silicosis in the last few years in a small community in the State of São Paulo, where ceramic industry is a major economical activity, an epidemiological survey of all exposed workers has been carried out, in order to assess the magnitude of the problem and to establish a comprehensive programme of control.

Among nearly 4,000 workers submitted to chest X-rays, from fifty industries, 150 cases of silicosis were detected.

At this time, these cases can be described following some epidemiological characteristics such as age groups, sex, race, occupational history and time of suspected exposure, as well as the results of screening spirometries.

No Paper provided.

MULTIPLE CAUSE-OF-DEATH DATA IN PNEUMOCONIOSIS SURVEILLANCE AND RESEARCH

L. WIDEROFF • D.O. Hryhorczuk • J. Holden

Cook County Hospital Department of Occupational Medicine, Chicago, Illinois, USA

ABSTRACT

Multiple cause of mortality data from Illinois were examined to 1) determine the degree of under-reporting in pneumoconiosis vital statistics based on underlying cause at death and, 2) explore the prevalence at death of diseases associated with pneumoconiosis. Five-year multiple and underlying cause of mortality rates of white males were compared at the state and county levels. A matrix was constructed to show the frequency of concurrent diseases.

From 1979-1984, the percentage of cases in whom pneumoconiosis was reported as the underlying cause of death was 29% for CWP, 22% for asbestosis and 55% for silicosis. State rates which included pneumoconiosis as a contributory cause in the numerator were thus 73%, 78% and 46% higher than underlying cause rates. There was a statistically significant geographical difference ($p < .05$) by county in the proportion of CWP cases reported as underlying cause. In the multiple cause analysis, lung cancer was reported in 38% of the asbestosis cases and tuberculosis in 4% of silicotics. One or more forms of COPD were found in 30% of CWP cases. While the concurrence of these diseases is well known, the analysis of multiple cause-of-death data promises new areas for hypothesis generation in pneumoconiosis research. For surveillance purposes, time trends and geographical patterns of co-existing diseases can be monitored. In addition, vital statistics based on multiple cause data more accurately quantify pneumoconiosis mortality, independent of the role which the certifying physician assigns the disease in the causal sequence leading to death.

No Paper provided.

NATIONAL SURVEY OF PNEUMOCONIOSIS SUPERVISION IN JAPAN

YOSHIHARU AIZAWA, M.D. • Tsutomu Takata, M.D. • Keizo Chiyotani,* M.D.

Kitasato University School of Medicine, Kanagawa, Japan

*Rosai Hospital for Silicosis, Tochiqi, Japan

INTRODUCTION

Though there are indications of recent decrease in occupational hazards in Japan, pneumoconiosis still remains quite prevalent.

The radiograph and the statement certifying the results of pneumoconiosis examination are submitted to the Chief of the Prefectural Labour Standards Office if a worker is diagnosed as having signs of pneumoconiosis on the chest radiograph. The mode of pneumoconiosis supervision is determined by the Chief of the Prefectural Labour Standards Office and is based on the assessment of the Prefectural Pneumoconiosis Examination Physician.

Pneumoconiosis statistics are annually issued from the Ministry of Labour.¹ They are based on data collected from each Prefectural Labour Standards Office throughout the country. However, the various modes of pneumoconiosis supervision remain to be established in regard to certain details. The present study, extending from April 1, 1985 to March 31, 1986, was carried out for this purpose.

MATERIALS AND METHODS

Examination and Supervision of Pneumoconiosis

Employers periodically have pneumoconiosis examinations conducted for workers exposed to dust. Workers engaged in the past in dust work may undergo such an examination if they so desire.

Pneumoconiosis examination under the provisions of the Pneumoconiosis Law or administered by Ministry of Labour Ordinance consists in obtaining occupational history related to dust work, a radiograph, clinical chest examination, examination for complications and pulmonary function tests.

Chest radiographs are classified according to the Japanese Classification of Radiographs of Pneumoconiosis. Radiographic appearances are classified into one of six categories (PR1 to PR4C). When pneumoconiotic signs are detected, clinical examination of chest and pulmonary function tests are conducted.

Pulmonary function tests consist in conducting spirometry, obtaining flow volume curve and making blood gas analysis if necessary. Percent vital capacity (%VC) normalized by the regression equation of Baldwin,² forced expiratory volume in one second (FEV1%), maximal expiratory flow at 25% FEV over height (V25/Ht) and alveolar-arterial oxygen

pressure difference (AaDO₂) each has a standard value as the basis for evaluating pulmonary dysfunction. The absence of pulmonary dysfunction is indicated by F(-), requirement for blood gas analysis as F(+) and a considerable degree of pulmonary dysfunction as F(++).

Workers who are presently or have been engaged in dust work are given health supervision. There are four modes of supervision. No. 1 is for the persons considered unaffected by pneumoconiosis while No. 4 is for persons whose radiographic appearances correspond to category 4 (limited to those with opacities larger than one-third the lung field, PR4C), or persons whose radiographic appearances correspond to Category 1, 2, 3 or 4 (limited to those with opacities smaller than one-third the lung field, PR4A and 4B) and who have considerable pulmonary dysfunction due to pneumoconiosis.

The No. 2 supervision requires reduction of exposure to dust, Nos. 3A and 3B require change of work. The No. 4 involves medical treatment which is also administered to persons suffering from complications.

Subjects

Copies of 44,531 statements of the results of pneumoconiosis examination were sent to us from 47 Prefectural Labour Standards Offices. 1,048 statements, not adequately documented, were excluded from those of the subjects analyzed. The copies of 43,483 statements indicated age, sex, mode of supervision, category of chest radiograph, complications, pulmonary dysfunction, history of dust work, symptoms and signs.

Methods

Nine members of the committee, headed by Dr. Keizo Chiyotani, carried out the present study. All data obtained were processed and analyzed by an IBM4341 computer operated in conjunction with SAS at the Kitasato University Computer Center.

RESULTS

Background of Subjects

Age distribution. The ages of 43,483 subjects ranged from 15 to 97 years with the mean and standard deviation being 50.1 and 8.4 years, respectively. 95.1% and 4.9% of the subjects were men and women respectively, whose age means and

standard deviations were 49.9 ± 8.5 and 55.2 ± 7.6 respectively.

40,679 persons were required to take the examination as opposed to 2,804 persons who volunteered for the examination. The mean age of those who took the periodical examination was 49.5, which was less than 59.1 of those who requested it.

Dust work. The types of main dust work were welding (21.9%), excavation (17.6%) and pottery manufacture (16.4%). A person's work was considered that in which he or she had been engaged for the longest time.

Mode of Supervision

General picture. Eight percent (3,483) of submitted cases was diagnosed as negative for pneumoconiosis according to the chest radiograph (No. 1 supervision). No. 2 supervision was found most frequently (74.7%), followed by No. 3A (11.4%), No. 3B (4.6%) and No. 4 (1.3%).

Mode of supervision according to age groups. Nearly all the persons in the age groups younger than 30 were classed as No. 1 or No. 2 supervision as shown in Figure 1. The percentage of No. 2 supervision was less in the older age groups, being 39.1% in the 70-or-older age group, while 80.5% in the 30-39 age group. Older age groups showed requirement for Nos. 3A, 3B and 4 modes of supervision than younger age groups.

Mode of supervision according to type of examinee. 77.9% of 40,679 persons who underwent periodical examinations were classed as No. 2 supervision as shown in Figure 2. The percentages of Nos. 2, 3A and 3B were almost equal in 2,804 volunteers.

Mode of supervision according to the type of dust work. The No. 2 mode was most frequent (83.5%) while No. 3B (0.5%) and No. 4 (0.2%) were rarely applicable among welders. Essentially the same modes were found applicable to foundry workers, grinding workers, refinery workers and glass workers.

The No. 2 mode was most frequent (57.3%), with Nos. 3A (19.1%), 3B (11.8%), 4 (4.9%) being somewhat less among excavators. Pottery makers and stonemasons required essentially the same modes of supervision.

Workers exposed to carbon, asbestos and cement indicated intermediate between welders and excavators.

Method for determining applicability of the No. 4 supervision mode. There were 562 persons classed as No. 4 supervision modes based on the considerable degree of pulmonary dysfunction (79.9%) and of PR4C (20.1%). Those evaluated as F(++) constituted about 75% the age groups younger than 60, and about 85% the 60-or-older age groups as shown in Figure 3.

Among those undergoing periodic examinations, 74 persons were classed as No. 4 based on the considerable pulmonary dysfunction (64.9%) and PR4C (35.1%). Of the 488 persons who volunteered for those examinations, 82.2% were classed as No. 4 owing to considerable pulmonary dysfunction.

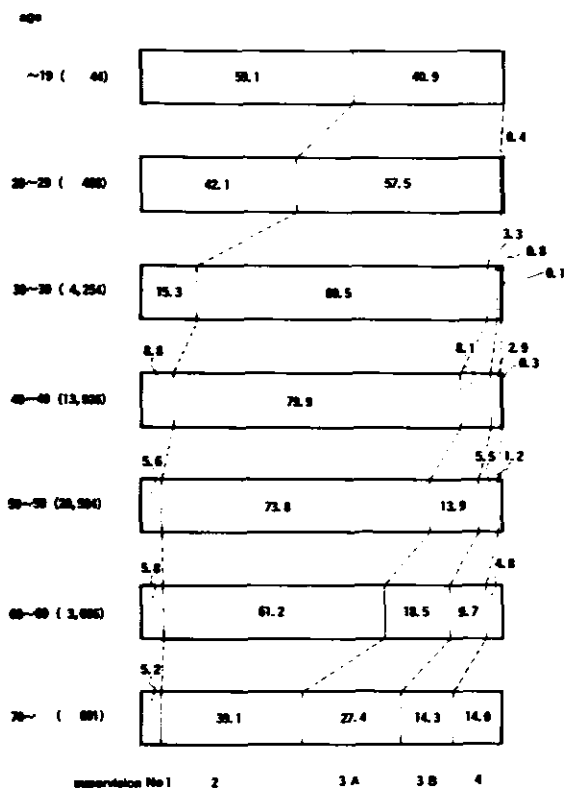

Figure 1. Modes of supervision according to age groups. Numbers in parentheses represent number of persons. Numbers in columns represent percentages of respective modes of supervision in each group.

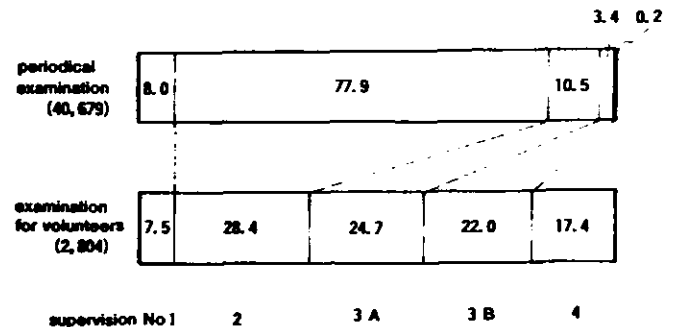

Figure 2. Modes of supervision according to type of examinee. Numbers in parentheses represent number of persons. Numbers in columns represent percentages of respective modes of supervision in each type of examinee.

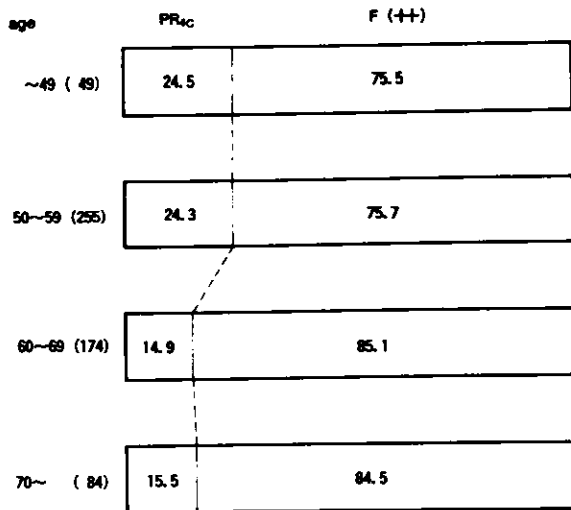

Figure 3. Basis for evaluation of No. 4 supervision modes according to age groups. Numbers in parentheses represent number of persons in each group. Numbers in columns represent percentages of respective bases for deciding on No. 4 supervision.

Complications

816 persons were diagnosed as having one or two complications. The 826 diseases afflicting the subjects were comprised of secondary bronchitis (47.3%), pulmonary tuberculosis (45.0%), pneumothorax (3.6%), tuberculous pleuritis (2.7%) and bronchiectasis (1.3%). Mean age of persons with complications was 59.3, compared to 50.0 for persons without complications.

Chest Radiographs

PR1 was found most frequently (74.8%), followed by PR2 (11.8%), PR0 (8.0%), PR3 (2.1%), PR4A (1.8%), PR4B (1.2%) and PR4C (0.3%). In the age groups younger than 30, PR0 and PR1 were applicable to nearly all persons. The percentage of PR1 was less in older age groups, such as 39.9% in the 70-or-older age group compared to 80.5% for the 30-39 age group. PR2, PR3 and PR4 were more frequent in older than younger age groups.

Pulmonary Dysfunction

Pulmonary function tests were conducted for 40,604 persons not diagnosed as having PR4C or any complications. 74.7% was assessed as F(-), 24.1% as F(+), 1.2% as F(++). F(++) was observed in 14.5% of persons 70 or older, while only in 0.1% of the 30-39 age group.

A considerable depression in %VC or FEV1% was noted in 58.5% of persons assessed as F(++). A considerable depression in V25/Ht and a considerable elevation in AaDO₂ was noted in 36.5% and 5.2% respectively of persons thus assessed.

DISCUSSION

Surveys of pneumoconiosis in Japan and other countries have already been reported.³⁻⁷ However, these reports are limited to certain medical facilities,⁵⁻⁷ areas,⁴ and dust works.³ Simple statistics of classification of pneumoconiosis are published annually by the Ministry of Labour.¹ This paper presents the first detailed study on the supervision of pneumoconiosis throughout the Japanese population.

The subjects studied were persons engaged, either presently or at some time in the past, in dust work and suspected of pneumoconiosis from their chest radiographs. A total of 3,483 persons (8%) were considered to have no indication of pneumoconiosis based on radiographs according to the Chief of Prefectural Labour Standards Office. There were thus 40,000 among 260,629 examinees (15.3%) with pneumoconiotic symptoms according to their radiographs. Since persons with negative pneumoconiotic signs on their radiographs are examined for this disorder once every three years, the prevalence rate may be calculated by dividing 40,000 by 589,758 persons engaged in dust work (6.8%).

The No. 4 mode of supervision requiring medical treatment was found applicable to 1.3% (562 persons) of all the subjects. It frequently applied to elderly persons and those who volunteered for the examination. The percentages of this mode were more than 1% in excavators, stonemasons, asbestos workers and cement workers.

In numerous cases, pulmonary dysfunction was the major basis for deciding on this mode. This was especially so for elderly persons and those who volunteered for the examination. Pronounced pulmonary dysfunction was mainly attributed to depression of %VC or FEV1%, with depression of V25/Ht rating as the second causative factor.

More than 90% of diseases causing complications were secondary bronchitis and pulmonary tuberculosis. The mean age of persons with complications was higher than that of persons without complications.

REFERENCES

1. *Annual guide of industrial hygiene in Japan*. pp. 226-228. Ministry of Labour, Ed. Japan Industrial Safety and Health Association, Tokyo (1986).
2. Baldwin, E.deF., Cournand, A. and Richards, D.W.: Pulmonary insufficiency I. Physiological classification, clinical methods of analysis, standard values in normal subjects. *Medicine* 27:243-278 (1948).
3. Crosbie, W.A.: The respiratory health of carbon black workers. *Arch. Environ. Health* 41:346-353 (1986).
4. Nagahama, F.: The clinical observations on pneumoconiosis in Hokkaido, especially on coal miners' pneumoconiosis. *Jap. J. Traumatol. Occup. Med.* 34:424-437 (1986).
5. Pulmonary function tests in pneumoconiosis. *The 56th Annual Meeting of Japan Association of Industrial Health*, Osaka, Japan (1983).
6. Supervision of health in pneumoconiosis. *The 59th Annual Meeting of Japan Association of Industrial Health*, Hiroshima, Japan (1986).
7. Yokoyama, T.: Evaluation of pulmonary function in pneumoconiosis. *J. Jap. Med. Assoc.* 90:1587-1593 (1983).

ACKNOWLEDGEMENTS: This study was supported by a grant from the Ministry of Labour in Japan.

AN HISTORICAL REVIEW OF AIRBORNE COAL DUST LEVELS AND THE PREVALENCE OF OCCUPATIONAL LUNG DISEASE IN NEW SOUTH WALES COAL MINES 1948-1988

DR. ROBERT GRIFFITS, M.B.B.S., F.A.C.O.M.

Senior Occupational Physician, Joint Coal Board, Newcastle, New South Wales, Australia

INTRODUCTION

There has been a dramatic reduction in the prevalence of Occupational Lung Disease in New South Wales coal miners following an intensive preventative program commenced by the Joint Coal Board in 1948.

At that time 16% of the 17,204 miners employed in the industry had radiological evidence of pneumoconiosis and 33% had clinical evidence of chronic bronchitis. Most of the 14.8 million tons of coal produced in 1947 was won by hand mining techniques. Ventilation was generally poor and airborne dust counts were high. Particle counts as high as 20,000 particles per cubic centimetre (p.p.c.c.) were recorded in the most dusty operations.

Mining methods have changed considerably since 1948. Widespread mechanization was introduced during the 1950's. Cutting and boring machines were introduced first and in turn gave way to the use of continuous miners.

Bord and pillar mining utilizing continuous miners is the main method of coal extraction today, although longwall mining and open cut mining has been assuming increasing prominence during the past decade. The industry currently employs 16,731 persons and in 1987/88 76.3 million tons of coal was produced. Open cut mining was responsible for 41.4% of coal production, and the output from longwall mining increased significantly to account for 18.7% of total production.

Today only 1% of mineworkers have pneumoconiosis. There are only eight cases of I.L.O. Category Two Pneumoconiosis or greater in the workforce. Progressive Massive Pulmonary Fibrosis (P.M.F.) is an historical curiosity. The prevalence of Chronic Bronchitis has dropped to 12%.

Most mines (even the majority of the longwalls) comply with the current 3 mgm/m³ gravimetric standard.

GEOGRAPHY

Most coal mining in Australia occurs in the states of Queensland and New South Wales on the east coast. Similar annual tonnages are produced in each state.

In New South Wales mining is principally located in four main areas: the Northern District around Newcastle, the North Western District near Singleton, the Southern District in the vicinity of Wollongong and Camden and in the Western

District around Lithgow. Most open cut mining occurs in the North Western District. Longwall mining is progressively being introduced in all districts.

PREVENTION AND MONITORING PROGRAM

In 1939, a Royal Commission conducted by Mr Justice Davidson inquired into the safety and health of workers in coal mines. Regulations to control dust levels were developed following the Commission, but they were not proclaimed until 1943.

In 1945 a second Royal Commission was held. The Commissioner asked Drs. Cilento and Murray and Mines Inspector Brewster to conduct a National Survey of the health of coal miners. One of the main recommendations of their report was the setting up of a medical scheme to allow chest X-ray and clinical examinations of all entrants to the industry. Similar periodic tests at two to three yearly intervals were also recommended for all working miners as a check for the incidence of industrial disease.

A major outcome of the 1945 Royal Commission was the establishment of the Joint Coal Board in 1946, which was given wide statutory powers to control, regulate and assist the coal mining industry. Included was the power to supervise and promote health, with provision to regulate the conditions in the industry with respect to the enforcement of measures for the abatement of dust in mines.

The Board established four Medical Bureaus in 1948 in the chief coal mining centres of Wollongong, Newcastle, Cessnock and Lithgow. A pathology laboratory to study post mortem lung and heart specimens from deceased coal workers was established at the Board's Newcastle Bureau in 1950.

The medical examinations performed by the Board's Medical Officers included the taking of occupational and general medical history, a physical examination and chest X-ray examination. Spirometry was added at a later date.

A comprehensive medical research program was commenced utilizing the post mortem preparations and data obtained during the medical examinations.

The first Pneumoconiosis Prevalence Study in New South Wales was conducted in 1948. A 10% sample of the 17,200 workforce was assessed. 16% of workers were found to have

pneumoconiosis, 4.5% had Category Two or worse, 0.7% had P.M.F. The majority of cases were found in the Western and Southern Districts. There were fewer cases of pneumoconiosis in the Northern District even though many more men worked in this district. This was consistent with the higher coal dust counts that were continually recorded in the Southern and Western Districts.

Dust sampling was first introduced in New South Wales coal mines in the mid 1930's. Early dust results varied widely between different collieries and with different activities within the same mine, largely reflecting differences in ventilation, watering and stone dusting practices.

Processes such as holing, picking down coal, filling skips and shot firing resulted in the production of large amounts of dust. In badly ventilated places dust exposure could be massive. Results following shot firing in one badly ventilated mine revealed a dust count of 20,000 p.p.c.c. one minute after a shot was fired, dropping to 15,000 p.p.c.c. after a further three minutes. In a better ventilated mine where the coal had been previously stone dusted and watered, a particle count of 144 p.p.c.c. was recorded one minute after the shot was fired.

Dust counts associated with the filling of skips varied, depending on ventilation, between 306 and 900 p.p.c.c. The average dust exposure on wheeling roads when skips were moved was 400 p.p.c.c. At certain positions in surface screening plants, counts as high as 15,000 p.p.c.c. were recorded.

In 1943 a "Permissible Airborne Dust Standard" of 700 p.p.c.c. in the 0-10 micron size incorporated into the Coal Mines Regulation Act of New South Wales. The Owens Dust Pump was the designated measuring instrument.

Following the advent at the Joint Coal Board and its engineering services in 1948, intensive periodic dust sampling was introduced into the industry. The Board decided soon after its establishment that all necessary engineering measures for the physical suppression of dust in mines would be undertaken. The most important measures identified were efficient face ventilation, wet cutting and wet loading, the application of water infusion in particularly dry seams and effective roadway consolidation. The Board encouraged the introduction of mechanization.

By 1955, 6.7% of coal production was mechanized and control measures were recorded as satisfactory in 99.2% of work places.

In 1954, the Board established a Standing Committee on Dust Research, which comprises representatives of colliery proprietors, mining unions, Government departments and medical and engineering personnel from the Board. The main roles of the committee were to: monitor the results of dust sampling; evaluate dust hazards; research improved dust control methods; disseminate information; and educate mine workers in matters related to dust control.

In 1957, a new Dust Standard was proclaimed. The upper limit of the size range was reduced to 5 microns and the maximum permissible limits were varied, depending on the free silica

content of the material being worked. The maximum permissible standard now became 700 p.p.c.c. for less than 10% free silica; 600 p.p.c.c. with 10-20% free silica, through a scale down to 200 p.p.c.c. with more than 50% free silica.

Average dust counts recorded for the four districts during the period January 1957 to December 1959 were as follows:

Cessnock	142 p.p.c.c
Newcastle	151 p.p.c.c
West	178 p.p.c.c
South	267 p.p.c.c

The Pneumoconiosis Prevalence Study of the three year period 1957-60 indicated that the prevalence of pneumoconiosis (I.L.O. Category $\geq 1/0$) had dropped to 3.6%. 385 of the 12,518 examined had pneumoconiosis; 116 men had pneumoconiosis X-ray Category Two or worse. There were three cases of P.M.F. Prevalence rates continued to fall.

The 1963-65 prevalence study indicated that 3% of the mining population had pneumoconiosis, 0.4% (28 men) had Category Two or worse disease and P.M.F. had become non-existent.

In 1967, the Dust Standing was again amended, following medical advice that particles less than one micron in size were relatively unimportant. Only particles in the 1-5 micron size were to be measured. The standard was amended to:

175 p.p.c.c. with less than 10% free silica
150 p.p.c.c. with 10-20% free silica
100 p.p.c.c. with 20-30% free silica
75 p.p.c.c. with 40-50% free silica
50 p.p.c.c. with 50% or more free silica

Continuing improvements in ventilation and dust suppression resulted in further lowering of average dust counts and reduction in the prevalence of pneumoconiosis (see Tables I and II).

By 1982, the average particle count had dropped to 46 p.p.c.c. in the Cessnock/Newcastle District, 105 p.p.c.c. in the Western District and 109 p.p.c.c. in the Southern District. The prevalence of pneumoconiosis I.L.O. Category I or greater had fallen to 1.5%, the prevalence of Category 2 or worse was now 0.04%. 12.8% of mineworkers and Chronic Bronchitis.

In 1984, particle counting was superseded by the introduction of personal gravimetric sampling. The regulations specified a limit of 3 mgm of respirable dust/m³ for dust other than quartz-containing dust. (Quartz containing dust is that dust which contains a quantity of quartz greater than 20% mass of the total sample taken.)

Five members of each production crew on all production shifts are sampled. Longwall production units are sampled at intervals not exceeding six months. Continuous miner units, surface and outbye areas of underground mines and hazardous areas in open cut mines are sampled at intervals not exceeding twelve months.

The personal monitoring equipment that has been adopted is

lightweight with a battery operated pump carried on the person and incorporates a plastic tube from the pump to the cyclone which is fitted within a forward facing hemisphere of 300mm of the wearers mouth/nose.

If any sample exceeds the maximum allowable limit of 3.0 mgm/m³ a resample must be taken within seven working days in similar circumstances to those existing when the sample was collected. The manager may be directed to carry out additional dust suppression procedures and sampling shall continue at appropriate intervals until satisfactory dust con-

trol modifications have been incorporated.

CURRENT SITUATION

The dust suppression results achieved in New South Wales have resulted in the virtual elimination of coal miners pneumoconiosis from the industry. Most continuous miner and longwall units comply with the new gravimetric standard (see Table III). Difficulties however are being experienced on some longwall faces in meeting the standard. In these situations personal respiratory protection is being used whilst

Table I
Average Particle Counts (p.p.c.c.)

DISTRICT	1957/59	1962/63	1967/68	1973/74	1975/76	1981/82
Cessnock	142	104	49	76	61	46
Newcastle	151	149	56	34	39	46
West	178	140	60	98	94	105
South	267	266	100	121	124	109

Table II
Changes in the Prevalence of Pneumoconiosis, Chronic Bronchitis and Obstructive Chronic Bronchitis with Time

	1984	57-60	63-65	71-74	77-80	80-83
<u>Pneumoconiosis:</u>						
ILO > 1/0	16.0%	3.6%	3.0%	3.0%	2.0%	1.7%
Category 2 or worse	4.5%	1.0%	0.4%	0.13%	0.06%	0.04%
<u>Chronic Bronchitis</u>						
All cases	33.0%	-	21.0%	17.6%	13.6%	12.8%
Obstructive C.B.	9.0%	-	6.0%	7.2%	3.3%	2.8%
Smokers	-	-	62.0%	72.0%	67.0%	63.0%
% Workforce examined	10.0%	85.0%	60.0%	96.0%	100.0%	100.0%

Table III
Maximum Dust Concentrations*
September 1987-July 1988

Respirable Dust Concentration mg/m ³	Longwall		Other Underground		Surface	
	No	Cumulative Frequency %	No	Cumulative Frequency %	No	Cumulative Frequency %
0 - 1	-	-	25	20	43	72.8
1 - 2	26	26	64	71	10	89.8
2 - 3	35	61	23	89.6	4	96.6
3 - 4	19	80	8	96	-	96.6
4 - 5	8	88	3	98.4	-	96.6
5 - 6	2	90	-	98.4	-	96.6
6 - 7	3	93	2	100	-	96.6
7 - 8	2	95	-	100	1	98.3
8 - 9	2	97	-	100	-	98.3
9 - 10	1	98	-	100	1	100
10 - 11	2	100	-	100	-	100

* Maximum reading of each set of 5 samples taken on each shift monitored.

further engineering measures are being developed. Although the reduction in the prevalence of pneumoconiosis has been outstanding this should not lead to complacency. Appropriate dust monitoring and medical surveillance should be maintained.

It is no longer appropriate to perform chest X-ray examinations at 2 to 3 year intervals given the low prevalence of occupational lung disease. The frequency of chest X-ray examinations will in future be determined by the results of gravimetric sampling. Personal gravimetric sampling will provide more meaningful assessment of dust related health risk.

REFERENCES

1. Clark, T.M.: Australian Experiences in Coal Dust Suppression. *Ann. NY Acad. Sci.* 1972 200:797-807.
2. Leigh, J., Wiles, A.N.: Chronic Bronchitis in Coal Workers in New South Wales, Australia. *Proc. of VI International Pneumoconiosis Conference*, Bochum FRG 1983 1:201-211.
3. Glick, M., Clark, T: Engineering Pneumoconiosis from the New South Wales Coal Industry. *Proc. of III International Conference on Coal Research*, Sydney, Aust. 1976 1:F.1-F1.11.
4. Glick, M.: Pneumoconiosis in the Coal Mining Industry, N.S.W. *Proc. of II Australian Pneumoconiosis Conference*, Sydney, Aust. 1978 D1-D1.9.
5. Cilento, R., Murray, H., Brewster, D.: *Report on a National Survey of the Health of Coal Miners*, Commonwealth of Aust., 1945.
6. *Joint Coal Board Annual Reports 1948-1987*.

REPORT ON THE "INTERNATIONAL SYMPOSIUM ON PNEUMOCONIOSES" IN SHENYANG, CHINA, 30 MAY-2 JUNE 1988

H. IDEL,* P.D. Dr. • K. Robock,† Prof. Dr. • H.-W. Schlipkötter,‡ Prof. h.c. Dr.

*Institut für Hygiene, Universität Düsseldorf, FRG

†Bergbau-Forschung GmbH, Essen, FRG

‡Med. Institut für Umwelthygiene an der Universität, Düsseldorf, FRG

The first symposium on pneumoconioses to be held in China was organized by the Institute of Occupational Medicine, Chinese Academy of Preventive Medicine, Beijing, China (Professor Li), the Shenyang Research Institute of Industrial Hygiene and Occupational Diseases, Shenyang, China (Professor Zhao), and the Medical Institute of Environmental Hygiene at the University of Düsseldorf, West Germany (Professor Schlipkötter). Of the 150 participants attending, 127 came from 20 different provinces in the People's Republic of China, and 23 came from 8 European countries, the USA, Japan and the WHO. A total of 74 read papers and 34 poster papers were given, on the following subject areas:

- Technology of Dust Prevention and Dust Measurement
- Epidemiology
- Etiopathogenesis and Pathology of Pneumoconioses
- Diagnosis
- Therapy.

On the first of these subject areas, reports were given of the results of person-related dust exposure measurements to supplement stationary dust measurements in order to get a better view of the personal dust exposure, which can vary very widely. The measurement strategies used in the European countries and in the USA were described and discussed, i.e. the frequency and location of gravimetric sampling and the techniques and different types of equipment used for taking the samples, including tyndallometer methods for measuring dust concentration. The basis used here remains the Johannesburg Convention and the ISO definition for measuring and assessing respirable (alveole-penetrating) dust, as was also clear from findings reported here from animal trials. The measurement of inhalable total dust (with particle sizes up to over 100 μm aerodynamic diameter) as practised hitherto in China and the gravimetric measurement of asbestos dust at workplaces were critically discussed. The problems of measuring the quartz content as a guide parameter of the fibrogenic risk of different dusts were discussed, and the importance of the surface properties and lattice structure properties of the quartz or dust particles was pointed out. Detailed reports were also given on measurement of welding fumes, on engineering methods of controlling dust in coal mines, and on person-related dust protection methods.

On the second of these subject areas, papers were read and discussed on epidemiological studies in coal mines, in the asbestos industry, and in workers exposed to flax dust and to

welding fumes, and on the incidence and development over time of silicosis, asbestosis, lung cancer, mesotheliomas and allergic disorders. One of the objectives in China is to establish permissible limit values for various substances and to adopt internationally recognized measurement methods, in order to be able to make international comparisons of epidemiological findings. By applying dust control methods, and also in particular by treating cases of tuberculosis, it has been possible in, e.g., the tungsten mining industry to prolong average life from 36 years (1956) to 58 years (1987) in cases of silicosis or silicosis/tuberculosis.

On the next subject area, the aetiopathogenesis and pathology of pneumoconioses, the importance of the particle deposition and particle clearance rates for the aetiology of pneumoconiosis were noted. Also the bronchoalveolar lavage (BAL) was emphasized as an important parameter for assessing the course of a pneumoconiosis. Here, important factors are the total number of lymphocytes, the ratio of the individual lymphocyte populations, and evidence of mediators. In addition to the BAL findings, reports were given of serological changes occurring in silicosis, some of which affect humoral defences or are of interest as autoimmune phenomena: elevated levels of coagulase, fibronectin, interleukin I, phospholipids and complement complex C3, and also of lysozyme, angiotensin-converting enzymes, circulating immune complexes and anti-nuclear antibodies. These serological changes can be almost completely inhibited by administering silicosis-effective substances such as PVNO and Tetrandrin.

As special histological characteristics of silicosis, attention was drawn not only to the criteria already mentioned but also to the deposition of collagen types I & III and fibrinogen as markers for the fibrotic process, and to multiplication of collagen type IV and laminine as indicators of blood vessel proliferation. Reports were given of studies on the use of (compressed-air) gun-placed concrete at high pressure in tunnel building and the effects—especially of the quick-setting additives used—in animal trials.

In the subject area of diagnosis of pneumoconioses, parameters suitable for early diagnosis of asbestosis were reported: bibasal crepitation as an indicator for alveolitis, siderocytes in the sputum, and presence of asbestos bodies and fibres as indicators of exposure. The reduced elasticity of the lung due to interlobar and perivascular fibrosis causes

disorders of lung perfusion and thus a restrictive insufficiency of ventilation with reduced gas exchange, even in the earliest phase of the disease. A computer aided system of classifying pneumoconioses was also described, and the benefits of computer radiography and computer tomography were described in detail. The importance of studies which collect data on miners starting before they ever go underground was emphasized, so that early and also short-term effects can be detected. Regarding X-ray diagnosis of pneumoconioses in China, it is important to note that from 1986 onwards, Chinese X-ray diagnosis complies with the ILO classification of 1980.

On the subject area of therapy, several authors reported on successes with inhalation and injection therapy with polyvinylpyridine-N-oxide (PVNO) in silicosis patients. Chinese

participants presented clinical trials on also additionally administering derivatives of Piperaquin and aluminium, covering more than 3000 cases treated. In vitro studies have shown that aluminium, zinc, nickel and cadmium likewise have a protective effect on the cell surface of macrophages against quartz. The same effect is reported from a Chinese anti-silicosis drug "Reduquin." The opinion held hitherto, on the basis of previous studies, that Tetrandrin in vitro has a cytotoxic effect on macrophages, has been contradicted by new studies showing that Tetrandrin markedly inhibits the quartz-induced cytotoxicity against macrophages, as measured by oxygen consumption, superoxide anion release, and hydrogen peroxide release. The progress made in the therapy of silicosis as outlined in these studies is of especial importance in China, where there is still a high incidence of new cases of progressive silicosis.

REDUCING BAG OPERATOR'S DUST EXPOSURE IN MINERAL PROCESSING PLANTS

ANDREW B. CECALA, MS • Jon C. Volkwein • J. Harrison Daniel

Bureau of Mines, U.S. Department of the Interior, Pittsburgh, PA, USA

INTRODUCTION

The purpose of this paper is to summarize a number of different research projects performed over the last few years that deal directly with lowering the dust exposure of the bagger operating fluidized air bag machines. Each of these projects investigated the possibility of using completely different methods and approaches. The first approach was to use a different type of bag valve. The next two approaches involved engineering controls which were implemented in and around the bag loading area. The last approach dealt with the control of dust sources from other areas of the plant or mill. The bag operator's function is to place empty bags on the fill nozzles as filled bags are ejected from the machine. This is quite a common practice since most mineral processing plants bag at least some of their products. In many cases, especially when bagging extremely fine product, the bag operator's dust exposure is one of the highest for the entire plant. In performing this job, the bag operator is exposed to two primary dust sources. The first is product blowback during the bag-filling cycle. As excess pressure is released from around the fill nozzle during filling, the excess air and product are forced out of the bag, creating a considerable amount of dust. The second major source is the sudden plume of product, commonly called a "rooster tail," thrown from the bag valve and fill nozzle as the pressurized bag is ejected from the machine. Individuals wishing to lower the bag operator's dust exposure should be able to do so by using one or more of the techniques evaluated by the Bureau of Mines over the past few years and shown to significantly lower operator dust exposure.

EVALUATION TECHNIQUES

In all cases, respirable dust concentrations in air at the bag operator's station were monitored by the same method. A 10-mm cyclone was attached either to the operator's lapel, or near the breathing zone. The 10-mm cyclone is used in the United States for compliance sampling of respirable dust as established by the Mine Safety and Health Administration. Threshold limit values for metal/nonmetal operations are listed in the Federal Register (CFR) Part 30-56-5-5 which is based on a 1973 recommendation from the American Conference of Government Industrial Hygienists.¹ The cyclone was connected to the dust monitor by tygon tubing to allow the operator to perform the job function with minimal interference. The tubing length was minimized to reduce any losses associated with dust adhesion to the inner walls of the tubing, although a previous laboratory evaluation showed negligible effects with various tubing lengths that were within

reason (1 to 3 meters). The same length of tubing was used in all cases for each analysis to further minimize any biases. The RAM-1 real-time aerosol dust monitor, built by GCA Corp., was used for all monitoring.^{*2} This device uses light scattering to determine the respirable dust concentration in an air sample drawn from the environment through the cyclone. This instrument was calibrated for respirable silica dust and was used to compare the relative change in the bag operator's respirable dust exposure determined before and after the implementation of each technique. The operator's exposure is a measure of the dust in the worker's breathing zone and not the actual dust breathed by the worker since most workers wear some type of respirator protection at these operations.

THE FOUR RESEARCH PROJECTS

The following four research projects were conducted.

Bag Valve Modification

The bag valve design plays an important role in the degree of dust generated from blowback during the bag filling process, the rooster-tail as the bag is discharged from the fill station, and the later dust exposure of workers loading the bags onto pallets. The effectiveness of five commercially available bag valves in reducing dust generated during bag filling, conveying, and the pallet loading process was evaluated. The five valves tested included standard paper, polyethylene, extended polyethylene, double trap, and foam. Two factors appeared to determine valve effectiveness. The first was the valve length; the longer the valve, the more effective it was in reducing product blowback and bag-generated dust. The second factor was the valve material. Foam appears to be the most effective material for reducing dust generation, followed by polyethylene, and then standard paper. Considering both length and material, the extended polyethylene was the most effective valve tested and resulted in a 62% reduction in operator exposure.³ An additional benefit with this valve is the dust reductions achieved at various locations throughout the bag conveying and pallet loading process (Figure 1). The extended polyethylene valve was also one of the most cost-effective of those tested, with an increase in cost of approximately \$6.85 per thousand bags (0.7 cent per bag) over that of the standard paper valve (Table I).

Dual Bag Nozzle System

A dual bag nozzle system was designed to reduce the major dust sources of the bag filling process. The inner nozzle is the

Table I
Increase in Valve Cost Above the Cost of the
Standard Paper Valve

Valve	Additional cost per 1000 bags, \$	Additional cost per bag, cents
Polyethylene.....	6.85	0.7
Extended polyethylene.....	6.85	0.7
Double trap.....	11.17	1.1
Foam.....	214.98	21.5

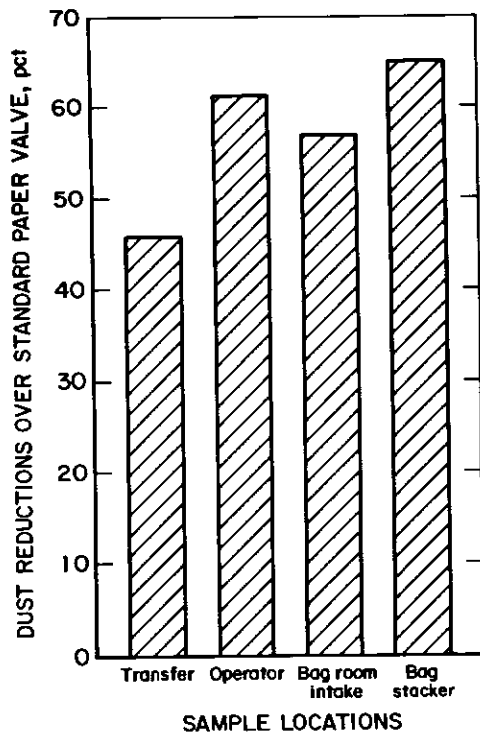

Figure 1. Airborne respirable dust reductions with extended polyethylene compared with that of standard paper valve.

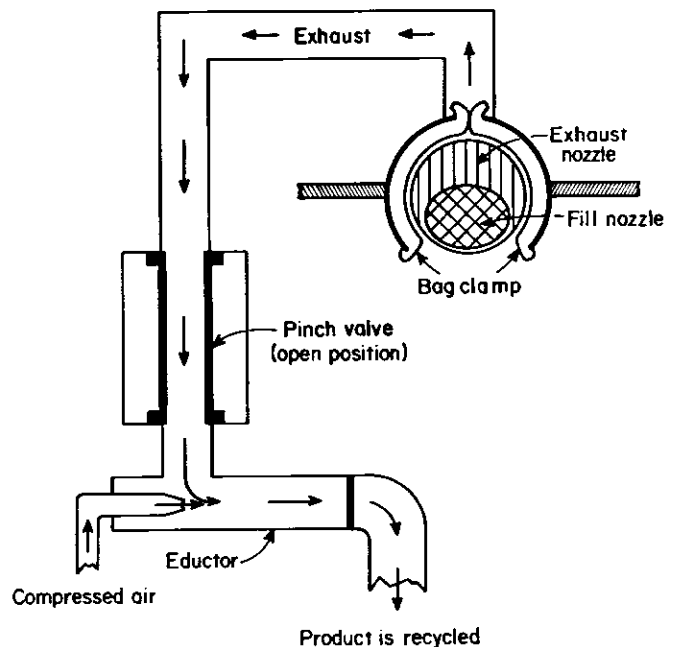

Figure 2. Dual bag nozzle system.

normal fill nozzle; the outer nozzle serves as an exhaust nozzle (Figure 2). The exhaust system is operated after completion of the bag filling process to remove excess pressure from the bag. The exhaust is powered by an eductor, which uses a venturi effect to exhaust the bag at approximately 1.42 m³/min (50 ft³/min). The exhaust airstream goes into a bucket elevator, which recycles the exhausted product. A pinch valve opens and closes the exhaust outlet. An improved bag clamp which makes direct contact with about 80% of the nozzle reduces the amount of product blowback during bag filling.^{4,5} A field evaluation was performed on this dual bag nozzle system during the second week of a 2-week test on a four-station bagging operation. During the first week, the

conventional system was monitored to determine the amount of dust generated. Over the weekend, the new system was installed and the identical test was performed for the second week of testing. Figure 3 shows the bag operator's dust exposure with the conventional system and the new dual-nozzle system when bagging 325-mesh product. There was an 83% reduction in dust exposure with the dual bag nozzle system. There was a 90% reduction in respirable dust concentrations measured in the hopper below the fill station which determined the reduction in product blowback during bag filling; this can result in tremendous product savings. A significant decrease in dust accumulation on the outside of the bag resulted in a 90% reduction in dust exposure of workers subsequently

stacking the bags onto pallets in enclosed vehicles. This system is suggested only for operations in which the bag operator fills bags from three or four stations. The production rate would decrease substantially for a one or two station system since the bag operator would be waiting on each bag as the exhaust system is operating, and thus would not be acceptable to most operations. The different components of this system can be fabricated by the mineral processing operations themselves or can be purchased from Foster-Miller, Inc., Waltham, Massachusetts, in which case the price would be dependent on the actual components necessary in each situation.*

Overhead Air Supply Island (OASIS)

The OASIS is an air cleaning device that is suspended over the bag operator and provides a flow of filtered air over the work station. It operates independently of the product processing equipment used. Mill air is drawn into the system and passed through a primary cartridge filter. This primary filter is self-cleaning, automatically using the reverse pulse technique when excessive filter restriction is sensed. The air can then pass through a heating or cooling chamber (optional), depending on the air temperature, and from there into a distribution manifold, which also serves as a secondary filter (Figure 4). The resulting filtered air flows down over the operator at an average velocity of 1.9 m/s (375 fpm), which restricts mill air from entering the clean air core.⁶ The OASIS was evaluated at two different operations by monitoring the bag operator's dust exposure with the device turned on and off. Figure 5 is a segment of strip chart that shows the operator's dust exposure during actual testing at the first operation. The dust reductions for these two operations were 98% and 82%, respectively. The primary reason for the difference between

these two values were the lower background levels, or off concentrations, at the second plant. At both plants, the dust concentration with the OASIS operating remained under 0.04 mg/m³. An additional benefit with this system is the overall reduction in dust levels in the mill building as a result of the OASIS's cleaning action which averaged approximately 12%. This system is commercially available from Donaldson Company, Inc., from Minneapolis, Minnesota, at an approximate cost of \$10,000 for a basic 6,000-cfm version; heating and air conditioning requirements are optional. The unit can also be fabricated in 3,000-cfm increments.*

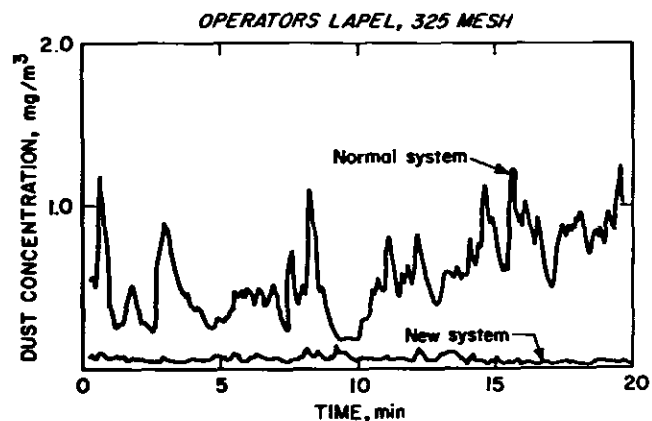

Figure 3. Operator's respirable dust exposure with normal system and dual nozzle system.

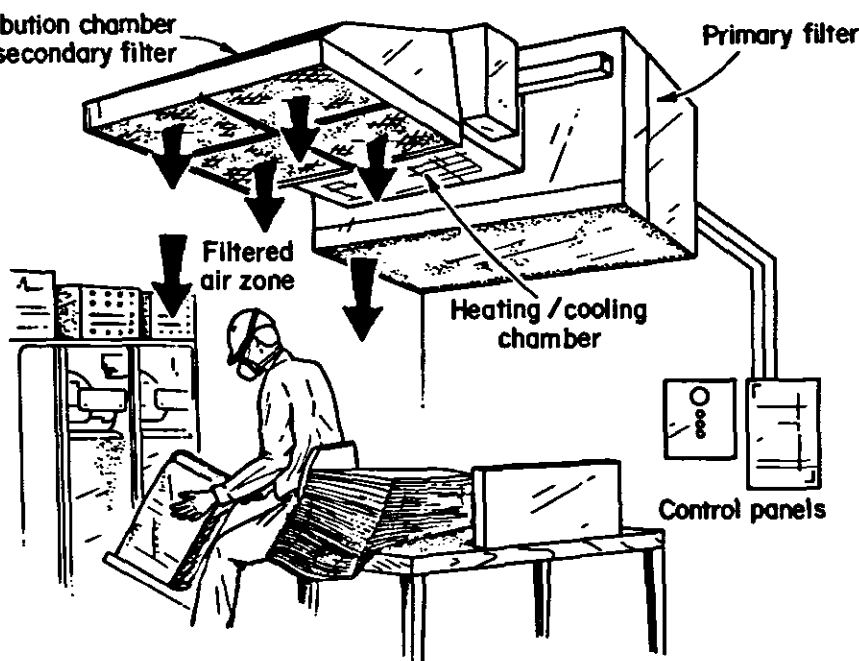

Figure 4. Overhead air supply island (OASIS).

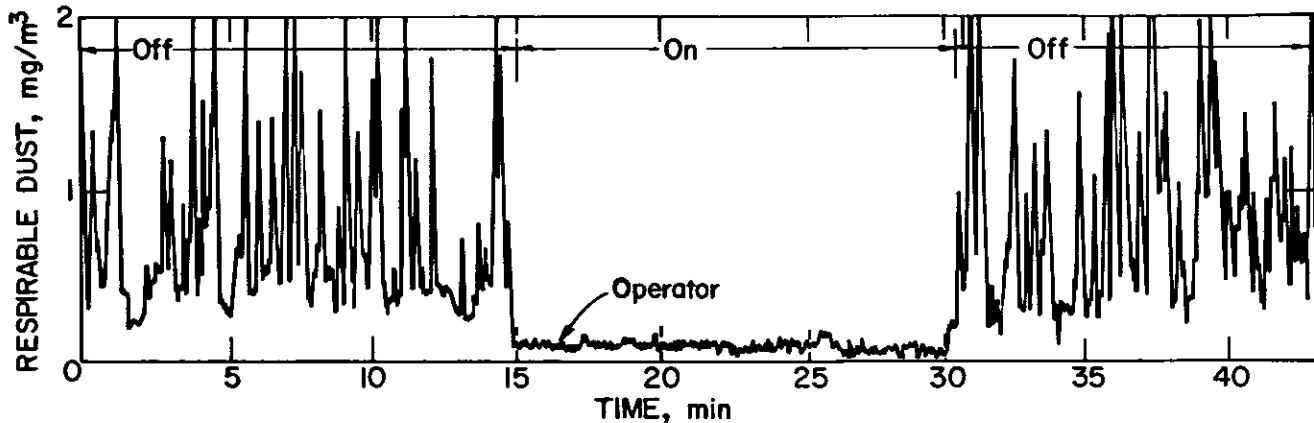

Figure 5. Operator's respirable dust exposure during bagging without and with OASIS.

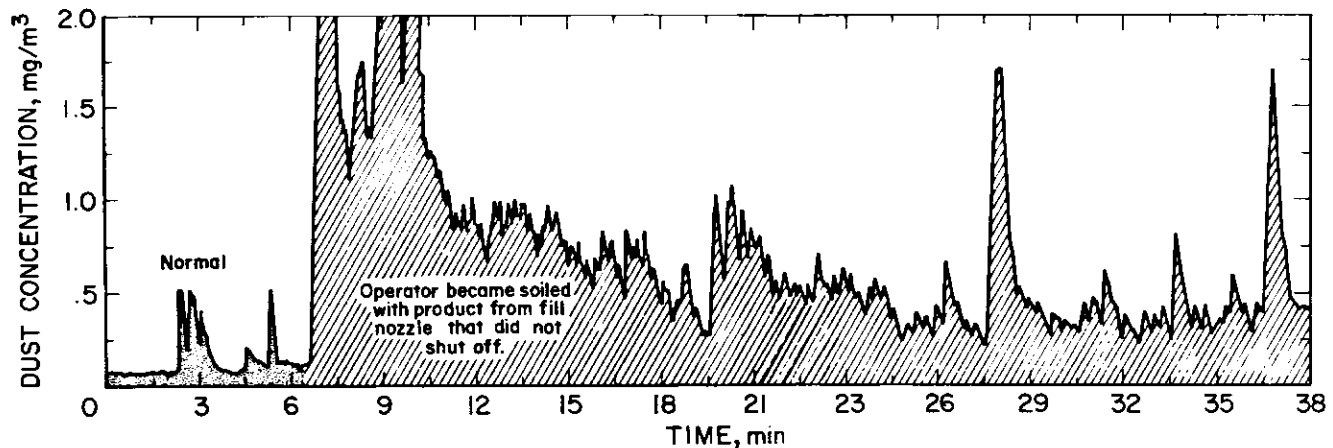

Figure 6. Operator's respirable dust exposure after becoming soiled with product from fill nozzle that did not shut off.

Control of Background Dust Sources

In addition to dust at the bagging station, a number of common background dust sources were identified in and around the bag filling area. These background dust sources, which are often unrecognized, can cause more contamination than the bagging process itself. Bag operators were monitored at their work station to determine different background contamination sources over the period of a workday. A number of different dust sources were observed to substantially increase the bag operator's exposure, in many cases as much as 5 to 10 times above the job function.⁷ These background sources include work clothes soiled with product material, blowing work clothes off with compressed air, bag breakage during loading and conveying, bulk loading outside, bag hopper overflow, and sweeping with brooms. Figure 6 shows a case in which the bag operator became soiled with product

from a fill nozzle that did not shut off after the bag ejected from the fill machine. The bag operator's respirable dust exposure before this occurred was approximately 0.1 mg/m^3 ; this increased to 1.01 mg/m^3 after the operator became soiled with product. Another example occurred while a truck was being bulk-loaded outside a mill where the bagging was performed. The dust generated from this bulk-loading process traveled through an open door into the mill, increasing the bag operator's exposure from 0.17 mg/m^3 before bulk loading began to 0.42 mg/m^3 (Figure 7). Over the period of the day, a substantial number of trucks may be bulk-loaded at this position, depending on customer orders. Thus, events not directly related to the bagging operation can be more significant sources of dust exposure to the bag operator than the bagging process itself. To effectively keep the operator exposure at acceptable dust levels, these background dust sources must be identified and controlled.

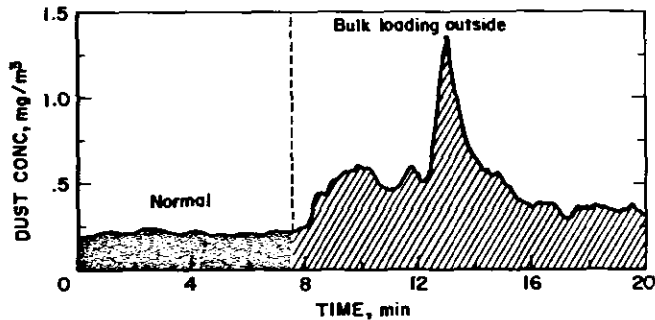

Figure 7. Bag operator's exposure from bulk loading outside.

DISCUSSION

The OASIS and dual bag nozzle system are available commercially. The dual bag nozzle system can also be fabricated at the plant, using the basic technology provided. Both of these engineering control techniques can lower the bag operator's dust exposure from 82-98%. The OASIS can also restrict dust from other sources from penetrating into the filtered envelope of air that flows down over the operator. Over a period of time, it also acts as a general air cleaner. The dual bag nozzle system significantly reduces the amount of product blowback during bag filling, which can also account for substantial product savings when lost product is not recycled. Since the system depressurizes the bag, much less product accumulates on the outside of the bag, thus substantially reducing dust generated during the conveyor and pallet loading processes. A 90% reduction in the dust exposure of workers stacking the bags into enclosed vehicles was also measured. The extended polyethylene bag valve is commercially available at an additional cost of 0.7 cent per bag, or \$3.36 per standard truck load of 480 bags. It is a cost effective way to reduce workers' dust exposure. There are basically two types of background sources. The first is operator induced dust, the second involves dust from external sources being drawn over the bag operator. Operator-induced dust sources include soiled work clothes, blowing clothes off with compressed air, and bag breakage on the fill station due to improper pressure settings. Soiled work clothes can be an especially significant factor in winter, when heavy coats may be worn for long periods without cleaning. Dust from the second type of source occurs when the exhaust ventilation system captures dust generated from other

areas of the plant. This is applicable in those cases where an exhaust ventilation system is located below the bag operator to capture any machine and bag-generated dust at the fill station. This creates a negative pressure which can draw dust from the mill over the bag operator unless a clean makeup air source is supplied. This was the case when bags were broken during conveying, during bulk loading outside, and when the bag hopper overflowed.

RECOMMENDATIONS

For mineral processing plants to keep bag machine operators' dust exposure at acceptable levels, plant operators must be aware of the different dust sources and methods to reduce these sources. Recent Bureau of Mines research has shown ways in which operator exposure can be reduced 62% to 98%. This information can be useful to any facility that packages product material into 50- to 100-pound bags. Comparison of various techniques in the actual working environment allows plant and mill operators to select methods best suited to their needs. Two of these techniques involve engineering controls that can be purchased commercially or fabricated at the plant. One technique involves simply acquiring a more efficient bag valve. The substantial effect of a number of different background dust sources on the bag operator's exposure must be recognized, and these dust sources must be identified and controlled.

REFERENCES

1. *Threshold Limit Values for Chemical Substances in the Work Environment Adopted by ACGIH*. ISBN 0-936712-45-7, American Conference of Governmental Industrial Hygienists, 6500 Glenway Ave., Cincinnati, OH 45211, 1973.
2. Williams, K. L., and R. J. Timko: *Performance Evaluation of Real-Time Aerosol Monitor*. Bureau of Mines IC 8968 (1984).
3. Cecala, A.B., Covelli, A., Thimons, E.D.: *Dust Reduction Capabilities of Five Commercially Available Bag Valves*. Bureau of Mines IC 9068 (1986).
4. Cecala, A.B., Volkwein, J.C., Thimons, E.D.: *New Bag Nozzle To Reduce Dust From Fluidized Air Bag Machines*. Bureau of Mines RI 8886 (1984).
5. Mukdoon, T.L., Valentine, J.W., Burnett, M.: *Bag Machine Dust Controls and Bag Sealing*. USBM Contract Report H0318013, NTIS PB86-153558 (1986).
6. Volkwein, J.C., Engel, M.R., Raether, T.D.: *Get Away From the Dust With Clean Air From an Overhead Air Supply Island (OASIS)*. Rock Products, July 1986.
7. Cecala, A.B., Thimons, E.D.: *Impact of Background Sources on Dust Exposure of Bag Machine Operator*. Bureau of Mines IC 9089 (1986).

*Reference to a specific manufacturer does not imply endorsement by the Bureau of Mines.

RECONSTRUCTION OF THIRTY YEARS OF FREE SILICA DUST EXPOSURE IN THE TACONITE INDUSTRY

J.W. SHEEHY • C.E. McJilton

National Institute for Occupational Safety and Health, Cincinnati, OH, USA
University of Minnesota, Minneapolis, MN, USA

INTRODUCTION

The School of Public Health of The University of Minnesota¹ conducted a study to evaluate the impact of past and present mining and processing activities on employee health in the taconite industry. The University of Minnesota health study proposed to examine cancer mortality in Northern Minnesota, develop mine worker rosters, and develop research proposals for the study of lung and heart diseases. One of the most important objectives of the health study is to associate current health effects with known levels of past and current exposures to potentially toxic agents in the taconite industry. As a result, an exposure profile by job title for silica containing dust was developed for taconite workers.

Eighty-eight percent of iron ore used in iron and steel making (1978) in the United States comes from taconite, a hard, fine-grained iron-bearing rock.¹⁻⁴ The taconite mines and mills on the Mesabi Range in Minnesota produce 63 percent of U.S. iron ore and employ 14,000 workers. The Mesabi Range³ is located 65 miles north of Duluth and northwest of Lake Superior and extends 120 miles from east to west. All the taconite mines are open pit mines.

This paper presents a summary of the exposure levels for silica containing dust for taconite mining and is based on respirable mass sampling data collected for the past 15 years, and impinger sample results collected from 1957 to 1975. From this data base, a matrix of respirable silica dust exposures over time and by job classification has been prepared.

METHODS

The establishment of current and past exposures to silica containing dust consisted of two major tasks: (1) compilation and summary statistics for a large amount of environmental sampling data by plant, job title, and time period; and (2) development of a model for converting historical environmental measurement data (impinger samples) into a form consistent with the current respirable mass sampling method. The results from the first task—a matrix of silica dust sample results—are summarized here; the development of the model is presented in a previous paper.⁵ The model was evaluated from parallel impinger and respirable mass sampling data using multiple regression techniques.

In this study, records of 16,000 dust samples for four taconite plants (designated as Plants 1, 5, 7, and 8) were obtained from the mining companies. These samples were taken by the

taconite companies and the Mine Safety and Health Administration (formerly Mine Enforcement Safety Administration) from 1957 to 1983; the authors also collected environmental samples in 1983-84 at taconite Plant 7. About 10,000 samples were impinger-particle count samples and the remainder were filter-respirable mass samples. From 1957 to 1975, impinger samples (nearly all midjet impinger) were collected at the Minnesota iron range taconite plants. The impinger method was recommended⁶ by the American Conference of Governmental Industrial Hygienists (ACGIH) in 1942, as the standard for environmental studies in dusty industries. In the Northern Minnesota taconite plants, the filter respirable mass sampling method replaced the impinger sampling method in the early and mid 1970's.

With the impinger sampler, dust particles are collected in a liquid in a glass impinger flask at 0.1 cubic feet per minute (cfm) or 2.8 liters per minute (Lpm) for between 10 and 30 minutes, and the particles are counted with an optical microscope. Impinger results are reported in million particles per cubic foot (mppcf). The impinger sampling data in this study were all from area samples.

Filter samplers consist of a filter preceded by the 10-mm cyclone, operated at an airflow of 1.7 Lpm. Filter samples are analyzed gravimetrically and are reported as milligrams per cubic meter (mg/m³) total respirable mass. Both personal and area filter samples, which were collected at these plants, were used in this study. Hi-volume samples were collected once or twice a year at Plants 1, 7, and 8 and analyzed for percent quartz.

The sampling data were compiled, entered on the computer, and a matrix of exposures by job title was prepared from respirable mass sample results. The validity of combining MSHA and company data were determined from non-parametric tests. Details of this analysis is reported previously.⁷ A matrix of area dust concentrations by sample location were determined from impinger sample results. In addition, job titles, job descriptions, and time-motion information were obtained from the plants through conversations with company workers, supervisors, and industrial hygienists. Time-motion information and geometric mean area impinger dust concentrations were used to determine an average impinger dust exposure for selected job titles.

Descriptive statistics consisting of the number of samples, geometric mean, log of the geometric standard error, and

minimum and maximum concentration, were obtained for the respirable mass data for 105 job titles. Respirable mass statistics for selected job titles are presented in this paper; the statistics for all 105 job titles are presented in a previous paper.⁷ In addition, for the most often sampled job titles, respirable mass exposures were determined for 3-5 year time periods. Impinger sample concentrations (1957-1975), by location, were determined. The geometric mean concentrations are reported for the data in this study because statistical analysis using various mathematical transformations, as well as original scale, showed that the dust sampling data were log normally distributed.⁷

RESULTS

Sample data, collected at the four taconite plants studied, show the potential for high crystalline silica exposure. Percent silica quartz levels, averaged over time for each of the taconite mine and mill departments, are shown in Table I. These results are based on high-volume total dust samples (Plants 1, 7, and 8) and respirable quartz filter samples (Plant 5). The average quartz levels were 18-34 percent in the mine, 28-37 percent in the crushers, 14-37 percent in the concentrators, and 5 percent or less in the pellet plant. Changes over time in percent free silica were not observed.

The NIOSH Recommended Exposure Limit (REL)⁸ for crystalline silica is a time-weighted average (TWA) concentration of 50 µg/m³ respirable free silica. However, because all silica samples in this study were analyzed by weight and not quartz, the NIOSH REL has been converted to a respirable mass TWA concentration by dividing the allowable quartz concentration of 0.05 mg/m³ by the maximum percent quartz level for each department. The OSHA Permissible Exposure Limit (PEL) and the MSHA Metal and Nonmetal Mining and

Milling standard^{9,10} for respirable crystalline silica is 10 mg/m³ divided by the quantity (percent SiO₂ plus 2), averaged over an 8-hour work shift. For example, if the respirable dust contained 100 percent silica, the calculated standard would be 0.10 mg/m³. Using the highest average quartz level in each of the taconite plant departments resulted in a PEL of 0.28 mg/m³ respirable dust for the mine, 0.25 mg/m³ for the crushers and concentrator, and 1.43 mg/m³ in the pellet plant. Some taconite plants, which show a lower average quartz content, may have a higher allowable TWA (PEL); however, because the silica quartz content may vary, the higher percent quartz value should normally be applied. The NIOSH REL, when converted to a respirable mass value, ranges from half to two-thirds the respirable mass concentration allowed by the OSHA PEL.

Respirable mass personal sample results collected during 1972-1984 for selected job classes are summarized in Table II. The jobs with the lowest exposure (averaged for the four taconite plants) were in the mine. The truck driver, shovel operator, and dozer operator, respirable mass exposures were approximately 0.20 mg/m³ respirable mass. Individual plant geometric mean exposures were lowest (0.07 mg/m³) for the truck driver and the highest (1.26 mg/m³) for the crusher laborer.

For the jobs in Table II, the highest respirable mass geometric mean concentration exceeded the NIOSH REL and the PEL for silica in all departments, except the pellet plant. The geometric mean concentration for the crusher laborer, the concentrator laborer, and concentrator maintenance man exceeded the NIOSH REL at all four plants. In the pellet plant, the highest geometric mean concentration for respirable dust was 1.0 mg/m³ for the pellet laborer, which is at the NIOSH REL and below the PEL of 1.43 mg/m³ for the pellet department.

Table I
(%) Silica Quartz Levels by Department from High Volume Samples

Location	Plant			
	1	5(a)	7	8
Mine	-	18	28	34
Coarse Crusher	32	33	32	37
Fines Crusher	35	28	(b)	(b)
Concentrator	20	14	22	37
Pellet	4	5	2	3

(a) Respirable mass filter samples

(b) Plant does not have Fines crusher

Table II
Respirable Mass Exposures by Job Title for Four Taconite Plants (mg/m³)

Job Title	Average 4 plants	Minimum	Maximum	NIOSH REL (a)	PEL
Shovel Operator	0.18	0.08	0.34	0.15	0.28
Truck Driver	0.20	0.07	0.33	0.15	0.28
Dozer Operator	0.20	0.14	0.29	0.15	0.28
Crusher Operator	0.30	0.11	0.59	0.14	0.25
Crusher Laborer	0.56	0.24	1.26	0.14	0.25
Conc Attendant	0.38	0.14	0.63	0.14	0.25
Conc Laborer	0.56	0.52	0.64	0.14	0.25
Conc Maintenance	0.43	0.37	0.47	0.14	0.25
Furnace Attendant	0.41	0.13	0.61	1.00	1.43
Laborer Pellet	0.61	0.43	1.00	1.00	1.43

$$(a) \text{ Adjusted NIOSH REL} = \frac{0.05 \text{ mg/m}^3}{\% \text{ quartz (area sample)}}$$

Table II includes the more frequently sampled job titles.

Respirable dust concentrations (geometric mean) among jobs in the open pit for the four taconite plants are compared in Figure 1. The exposures for the shovel operator, truck driver, dozer operator, and drill operator were lowest at Plant 1 and highest at Plant 5. Within individual plants, exposures among job titles in the mines were very similar. Exposures to respirable dust for three jobs in the crushers are compared in Figure 2. The mean respirable dust concentrations for the crusher operator were generally lower than for the coarse crusher laborer and fines crusher attendant. The geometric mean respirable mass concentration for the Plant 5 crusher laborer was 1.26 mg/m³, more than 3 times the exposure of the crusher laborers at the other three plants. Plants 7 and 8 did not have a fines crusher. Figure 3 shows respirable dust concentrations (geometric mean) for the concentrator attendant, laborer, and maintenance man. The laborer and maintenance man's exposures were nearly identical at Plants 5, 7, and 8, while the attendant's exposure at Plants 7 and 8 were 4 times greater than at Plants 1 and 5.

In addition to stratification by job class, respirable dust exposures were grouped into three time periods. The results for five job titles, presented in Table III, show differences in some exposures between the period 1972-1976 and 1980-1983. For some jobs, such as the truck driver at Plant 7, there were almost no changes in respirable dust exposures over time. On the other hand, exposures well above the PEL for the concentrator laborer, decreased by as much as 74 percent from 1972-76 to 1980-83 (t-test results show a highly significant difference in geometric mean respirable mass concentrations between the two time periods). This reduced the concentrator laborer's exposure from much above the standard to 0.27

mg/m³; which is between the NIOSH REL of 0.23 mg/m³ and the OSHA PEL of 0.42 mg/m³ for Plant 7 concentrator. The decrease in dust exposures appeared to be the result of introducing wet methods in grinding operations in the concentrator.

Figures 4 and 5 show changes in respirable dust exposures for jobs in the Plant 1 coarse crusher and Plant 7 concentrator. In general, respirable dust exposures for jobs in the coarse crusher of Plant 1 did not decrease over time, whereas respirable dust levels for all three jobs in the concentrator of Plant 7 showed significant decreases in the 12 year period.

Before the early 1970's, only impinger dust samples were collected at the taconite facilities. Several taconite plants have operated since 1957 and three others since 1968. During this period, a large number of impinger samples were taken at Plants 1, 7, and 8. The geometric mean impinger dust count concentrations for ten sample locations in the concentrator at Plant 1 are presented in Table IV. The results are shown for five time periods from 1957 to 1975, and are based on a minimum of three samples per location for each time period.

Because impinger dust samples are area samples and are collected by a different sampling method, two steps were required to make impinger sample results comparable to the respirable mass sample data: (1) the geometric mean impinger sample concentration for each location is multiplied by the percentage of time worked at each location and then summed for a particular job title; and (2) the mean impinger dust count concentration (mppcf) for the particular job title is then multiplied by a ratio (developed by the authors) of filter respirable mass concentration to impinger dust count concentration. The latter step is presented in an earlier paper.⁵

Table III
Changes over Time in Respirable Mass Exposures* (mg/m³)

Job	Plant	1972-76	1977-79	1980-83
Truck Operator	1	0.10	0.08	0.06
	7	0.27	0.23	0.25
	8	0.09	0.19	0.14
Shovel Operator	1	0.17	0.08	0.05
	5	0.34	0.37	0.27
	7	0.17	-	0.06
Concentrator Secondary Attendant	5	0.25	0.22	0.38
	7	0.61	0.27	0.21
	8	0.57	-	0.24
Concentrator Laborer	5	0.76	0.53	0.27
	7	1.05	0.37	0.27
	8	0.99	0.67	0.40
Furnace Attendant	1	0.12	0.16	0.10
	5	0.59	0.62	0.65

* Geometric mean concentration

Table IV
Dust Count Concentrations at Locations Where the
Concentrator Laborer Worked (mppcf)

Sample Location (in Concentrator of Plant 1)	Geometric Mean				
	1957-59	1960-63	1964-67	1968-71	1972-75
Conveyors #7 & 107	1.5	3.4	3.1	3.5	-
West Conveyor #8	0.4	0.4	0.6	0.6	0.8
West Rod Mill	0.5	0.6	0.5	0.6	0.5
West Filter Floor	0.2	0.4	0.6	0.9	1.0
West Conveyor #10	0.4	0.3	1.1	1.7	-
East Conveyor #108	-	-	0.6	-	-
East Conveyor #109	-	-	0.6	0.8	0.7
East Rod Mill	-	-	0.5	1.0	0.7
East Filter Floor	-	-	-	1.0	1.2
East Conveyor #110	-	-	-	2.6	-

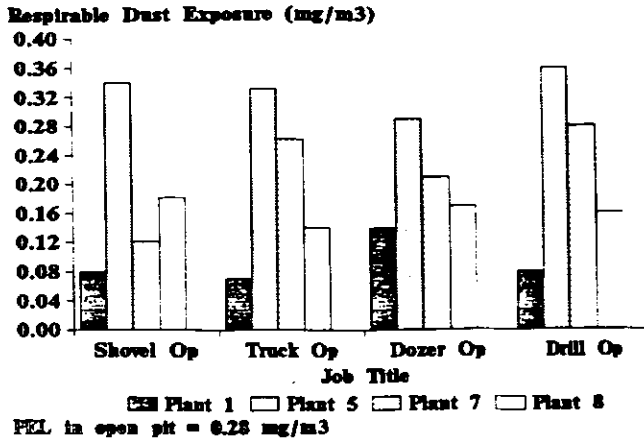

Figure 1. Respirable dust exposures in the open pit.

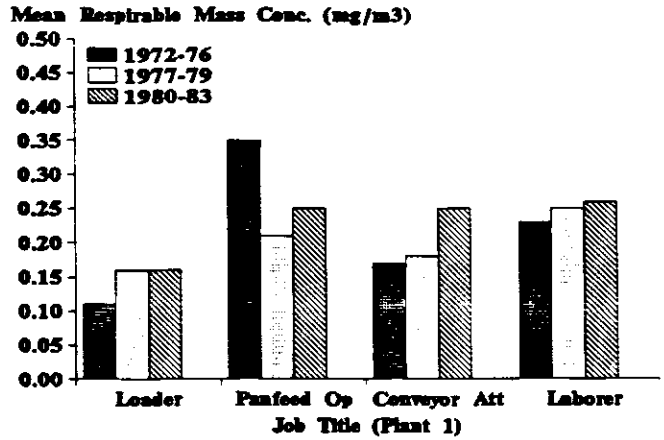

Figure 4. Respirable dust exposures over time in coarse crusher.

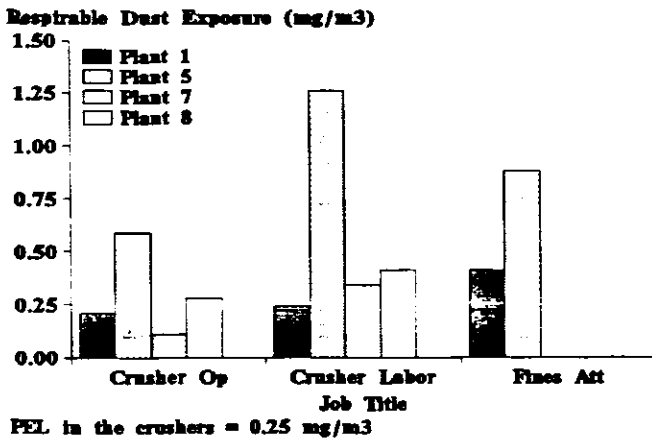

Figure 2. Respirable dust exposures in the crushers.

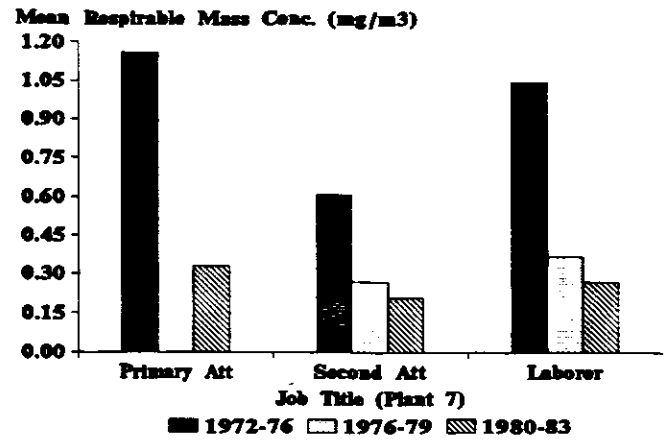

Figure 5. Respirable dust exposures over time in concentrator.

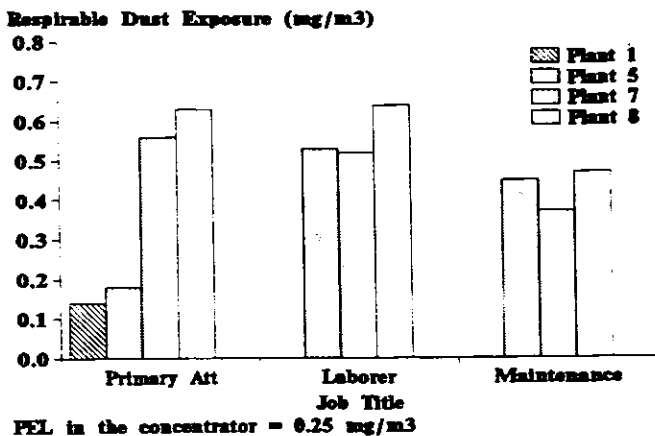

Figure 3. Respirable dust exposures in the concentrator.

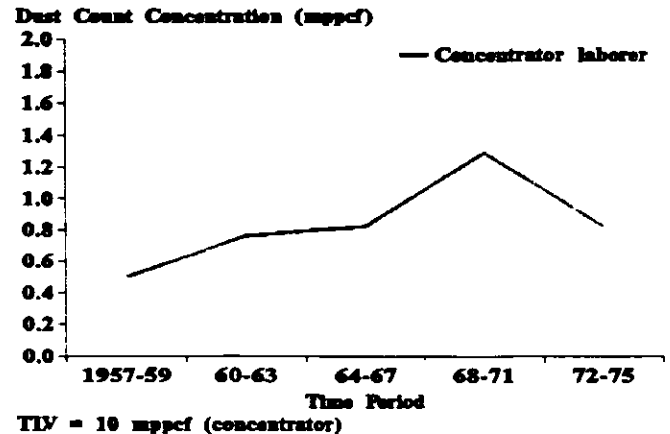

Figure 6. Estimated impinger dust exposures for conc. laborer at Plant 1.

To accomplish the first step mentioned above, the percentage of time the concentrator laborer spent at each location was determined. This percentage of time was then multiplied by the impinger area sample concentrations in Table IV to obtain an estimated impinger dust count exposure for the time period. An estimated impinger dust count exposure (mppcf) versus time for the concentrator laborer (solid line) is plotted in Figure 6. It shows the laborer's dust count exposure increased until 1968-71 and then decreased.

CONCLUSIONS

Quantitative exposure levels to silica-containing dust were determined for the taconite mines in Minnesota by analyzing both respirable mass and impinger dust count samples. These quantitative exposure data, briefly summarized here, are now available to epidemiologists attempting to determine the relationship of dose (quartz) to disease in the taconite industry, especially diseases with long latency such as cancer and silicosis.

A major task in analyzing the sample data collected before 1976, was to estimate personal respirable mass exposures from area impinger dust samples. This was accomplished by calculating geometric mean dust count concentrations at the sample locations and factoring in time-motion information for specific job titles.

Exposures to silica containing dusts in the mine, crushers, and concentrator exceeded the NIOSH REL and the OSHA PEL at some of the taconite plants. Exposures for jobs in the concentrator exceeded the REL and PEL at all 4 plants. Jobs in

the pellet plant were below the REL and PEL.

However, these mean exposure values, encompassing exposures from about the 1970's to the early 1980's, hide changes in exposures such as those due to improved control technology. For example, jobs in the concentrator of Plant 7 showed significant decreases in exposure over 12 years due, in part at least, to the introduction of wet grinding methods.

REFERENCES

1. *Proposal—Mineral Resources Health Assessment Program*. Division of Epidemiology, School of Public Health, University of Minnesota. March, 1980.
2. West, R.: *Mining Environmental Target Investigation Taconite*. National Institute for Occupational Safety and Health. (Draft). May, 1982.
3. *Making, Shaping, and Treating of Steel*. United States Steel Corporation. Pittsburgh. 1971. pp. 178-239.
4. Minnesota's Iron Mining Industry. *The Iron Mining Industry of Minnesota*. 4th printing. 1978.
5. Sheehy, J.W., McJilton, C.E.: Development of a Model to Aid in Reconstruction of Historical Silica Dust Exposures in the Taconite Industry. *Am. Ind. Hyg. Assoc. J.* 48(11):914-918. November, 1987.
6. Davis, I.H., Ayer, H.E.: *Panel on Evaluation of Exposures to Mineral Dusts*. U.S. Department of Health, Education, and Welfare, PHS. Cincinnati, Ohio. May 1966.
7. Sheehy, J.W.: *Reconstruction of Occupational Exposure to Silica Containing Dust in the Taconite Industry*. Doctoral Dissertation. University of Minnesota, Minneapolis, Minnesota (February 1986).
8. NIOSH. *Criteria for a Recommended Standard... Occupational Exposure to Crystalline Silica*. HEW Publication No. (NIOSH) 75-120, GPO No. 017-033-00050, U.S. Government Printing Office, Washington, D.C. 1974.
9. Silica Flour: *Silicosis Current Intelligence Bulletin 36*. US Dept. Health and Human Services (NIOSH). June 30, 1981.
10. *Occupational Health Guidelines for Chemical Hazards*. DHHS (NIOSH)/DOL (OSHA) Publ. 81-123. Cincinnati, Ohio. 1981.

ONE SOLUTION TO CONTROL—CAREFUL APPLICATION OF KNOWN TECHNOLOGY

K.J. CAPLAN

PACE Laboratories, IHE Division, Minneapolis, Minnesota, USA

ABSTRACT

The crushing plant for an open-pit copper mine had a one-year old conventional blast-gate-balanced dust collecting system which was requiring high maintenance due to eroding ducts and elbows. Dust concentrations were about 4 times the allowable by British Columbia standards, consequently workers were required to wear respirators.

A new ore body was being developed which assayed 25% quartz, as compared to the old ore body at 10% quartz.

Corrections consisted of a new balanced dust collecting system using the existing wet scrubber; revisions to belt transfer chutes and hoods; a vacuum cleaning system; and a make-up air system. Roof beams and wall girts inaccessible for vacuum cleaning were provided with sloped sheet metal covers. Relatively minor revisions to inlet and outlet ducts permitted the scrubber to operate at full capacity.

These revisions resulted in a 10-fold reduction in dust exposure and a 4-fold reduction in dust load to the collector. In the first year of operation, one duct elbow required replacement.

These results were achieved by competent, careful application of known technology in dust collection and bulk material handling. All but one ventilation design point is included in the ACGIH Ventilation Manual; and that point was in the nature of solving a difficult design problem, not "new technology."

Specific design improvements are described and/or illustrated, and dust concentrations tabulated.

No Paper provided.

DUST CONTROL AND OCCUPATIONAL EXPOSURE TO SILICA IN THE UNITED KINGDOM

J. TICKNER, M.Sc.

Health and Safety Executive, Bootle, Merseyside, United Kingdom

INTRODUCTION

In the United Kingdom, measures to limit exposures to crystalline silica have been incorporated in industrial health and safety legislation for well over 100 years. In general, statutory requirements for dust control have appeared in Regulations relating to individual industries such as potteries or foundries and have specified the means by which control is to be applied (e.g. the use of extract ventilation or the wetting of dusty materials).

The development of quantitative techniques for dust sampling, together with procedures for assessing exposures and the evolution of exposure limit philosophies opened up possibilities for determining the practical effectiveness of control measures. For the past 10 years or so, comprehensive reviews of occupational exposures have been prepared by the Health and Safety Executive for a wide range of substances hazardous to health. These reviews are presented to the Advisory Committee on Toxic Substances (ACTS), which is a tripartite body set up to advise the Health and Safety Commission and which determines occupational exposure limits for the United Kingdom.

In 1987, a review of exposure to crystalline silica was prepared, which considered sampling data and information on control measures from a variety of sources. Much of the data in this paper is based on that review.

DEVELOPMENTS IN LEGISLATION

At the same time as the ACTS review of crystalline silica was in progress, proposals for an important new set of Regulations were reaching a critical stage in their development. Until now, the conventional historical pattern for health and safety legislation has been to make Regulations for specific substances (e.g. asbestos, lead), or for individual industries such as ship building or construction. This meant that provisions for safeguarding occupational health often appeared in piecemeal fashion and controls required in one industry would not necessarily be required in the same form in similar circumstances in another.

New legislation, to be known as the Control of Substances Hazardous to Health Regulations is now proposed which will require adequate control of all substances hazardous to health wherever they are used at work. For a substance such as silica, which is found in a wide range of industries, the new Regulations should be of great assistance in achieving a uniform standard of control to meet formal occupational exposure limits.

THE INCIDENCE OF EXPOSURE TO SILICA

Crystalline silica is found in a wide range of materials used for a variety of purposes in manufacturing industry as well as in quarrying and tunnelling activities. The United Kingdom has long had experience of the traditional "dusty trades" such as potteries and foundries, which make extensive use of silica-containing materials and there is also extensive manufacture of bricks, tiles and refractory materials. Significant silica exposure is also found in stonemasons' work. The size of the industrial sectors where exposure to crystalline silica is found has changed considerably over the past 30 years. A general diminution in the extent of manufacturing industry has led to a corresponding reduction in the numbers of persons exposed to silica in some industries. In potteries for example, the total number of persons employed in the industry is estimated to be 30,000 - 40,000 which is about half the total employed in the early 1950s. For foundries, the decline is considered to be even more marked.

For non-manufacturing industry, quarrying is the largest sector where exposure to silica occurs. Significant exposure is found during the working of a wide variety of materials including granite, basalt, sandstone, coal and limestone. Tunnelling can also produce extensive exposure during major civil engineering projects.

DISTRIBUTION OF EXPOSURE DATA

Because of the wide range of industrial activities where silica exposure is found, the quantity of personal sampling data and the assessment of exposures and control measures are very variable. In some sectors, such as brick and tile manufacture, only limited data is available while for others, detailed assessment of specific processes have been made. Foundry data, for example, covers a wide range of activities including knockout, fettling and grinding, where control problems have been difficult to solve.

A total of some 3,000 personal exposure samples were assessed for the ACTS Silica Review. The data was all collected by Health and Safety Executive staff, usually by an occupational hygiene Specialist Inspector directing a small team of scientific staff who collected and analysed the samples. Much of the data was obtained in the period 1979-1986 and resulted from factory and site visits made for one of two purposes:

1. As part of a prospective survey of particular industries such as potteries in order to determine the extent and patterns of exposure.

- In response to requests from HM Inspectors of Factories to assess conditions at specific premises. In these cases, the Specialist Inspector would undertake a comprehensive occupational hygiene survey, sampling as necessary, and make recommendations for improvements and/or enforcement action based on his professional judgement.

In general only a small proportion of the results obtained were taken over an 8-hour sampling period but many of the work activities involved were such that 8-hour time weighted averages could be reliably assessed from exposures of shorter duration. In some instances, notably stonemasons work, airborne crystalline silica is generated intermittently and the estimation of a true time-weighted average is more difficult unless sampling extends over the full 8 hours.

Samples obtained for enforcement purposes tend to be biased towards higher levels of exposure, as the survey request will have followed from an initial observation that airborne concentrations appear to be high. It is also true that high levels of airborne silica may not always indicate high exposure as the sampling does not take into account whether respiratory protective equipment is being worn.

Of the total number of samples, approximately 1100 were obtained for manufacturing industry in all forms, 1300 for tunnelling and 500 for quarrying. In manufacturing industry, approximately 46% of the samples were obtained in foundries, 37% in potteries, 10% in brick and tile manufacturing and the remainder in refractory and stonemasons work. This distribution of samples does not reflect the distribution of the exposed population, and is biased towards the foundry industry, partly because high airborne silica concentrations have been found and partly because there is a variety of processes in foundries at which silica-bearing dust is generated.

AIRBORNE DUST CONCENTRATIONS

In considering the sampling data, it may be useful for comparison purposes to record the relevant current United Kingdom occupational exposure limits. These are:

- 0.1mg/m³ for respirable crystalline silica.
- 5mg/m³ for respirable dust for which no lower limit is specified elsewhere.
- 10mg/m³ for total inhalable dust for which no lower limit is specified elsewhere.

Most of the 3000 or so samples covered by the review were analysed to determine airborne dust concentrations for each of these categories.

For manufacturing industry, 65% of 1058 samples indicated less than 0.1mg/m³ respirable crystalline silica and 19% were in excess of twice the exposure limit. The majority of the higher dust concentrations occurred in the foundry industry, largely at fettling processes. Tunnelling gave a similar distribution of samples for respirable crystalline silica, with 35% of 1292 samples in excess of 0.1mg/m³ and 15% above 0.2mg/m³. In quarrying, higher dust concentrations were generally found—64% of 474 samples exceeded 0.1mg/m³,

with 10% in excess of 0.5mg/m³.

For respirable dust, the proportion of samples exceeding the 5mg/m³ limit was in the range 5%—10% for all industries, with variations within this range dependent upon the proportion of silica in the material being worked. A uniform pattern of total inhalable dust concentrations was also observed for all industries, with 75% of samples less than the 10mg/m³ exposure limit.

CONTROL MEASURES

Partly as a result of developments in legislation, renewed attention is being paid to the control of occupational exposure to hazardous substances in the United Kingdom at present. Effective control is perceived as encompassing a wide range of factors including both "hardware" such as extract ventilation and engineering modifications to process plant and the supporting "software" which ensures that the hardware is used to the best effect. The overall management health and safety structure, line management supervision, the provision of adequate training in the use of control measures and a good system of preventive maintenance are all part of this support system without which the control measures installed will inevitably lose their effectiveness.

All the major conventional means of preventing and controlling the generation of dust were found in the industries surveyed, including substitution, enclosure, control at source by local exhaust ventilation and process modification. In some circumstances, respiratory protective equipment was also needed in order to reduce exposures to less than the appropriate occupational exposure limit. In common with most other countries, however, the United Kingdom Health and Safety Executive policy regarding the use of respiratory protective equipment is to accept it only as a solution of last resort and to seek effective control by other means wherever possible.

For most of the processes and activities surveyed, effective control of airborne respirable silica to less than 0.1mg/m³ could be achieved without great difficulty. In potteries, for example, high silica-content material can often be replaced by less hazardous alternatives (e.g. the substitution of calcined flint by calcined alumina) and wetting of materials is a very effective way of inhibiting dust generation during handling. However, a good standard of general cleanliness and housekeeping is still required to ensure that scrap spillages are effectively removed and not allowed to dry out and create a potential dust problem.

Foundry processes are more difficult to control effectively, problems are much reduced in modern plant of good design. Fettling remains the most problematic of processes, although advances have been made recently in the automatic fettling of small simple castings, which remove the operator from the source of dust. For larger castings, fettling must still be done with a hand-held or swing-frame grinder. Where the work can be done in a booth with an efficient extraction system, good control should be possible but for very large castings there may be no practicable alternative to the use of respiratory

protective equipment to supplement conventional control measures. A similar situation occurs with repair and re-lining work on furnaces and ladles, where high concentrations of crystalline silica are generated during work on refractory linings. Again, at present it will often be necessary to supplement a good standard of ventilation with the use of respiratory protective equipment.

The major activity in the quarrying industry is the production of large quantities of low-value minerals such as roadstone. Plants with throughputs of 500 tonnes per hour are not uncommon and airborne dust quantities produced during mechanised processing are large—up to 0.5% of the process mineral throughput can be retrieved by dust collection. Wet suppression, enclosure and local exhaust ventilation techniques are used as circumstances demand, but are not always able to achieve control of exposures to the same standard as manufacturing industry.

CONCLUSIONS

Personal sampling data over a wide range of industries in which crystalline silica-containing material are used indicate that for many processes effective control of airborne dust can be achieved to current United Kingdom occupational exposure limits. Some problems remain difficult to solve, and in these cases respiratory protective equipment is used to supplement engineering control measures.

Control measures are not always used to their maximum effectiveness. Where this occurs, there is usually a need for improving the general awareness of the importance of dust control from the occupational health and safety viewpoint and securing greater commitment to the effective use of existing control measures. Developments in legislation in the United Kingdom and the preparation of supporting technical guidance by the Health and Safety Executive should assist in generally raising standards of control in industry.

AUXILIARY VENTILATION PLANT AND AIR DISPERSED PARTICULATES: AN EXPERIMENTAL STUDY IN THE STOPES OF AN ITALIAN TALC MINE

C. CLERICI* • G. Gecchele* • M. Patrucco* • G. Longo†

*Politecnico di Torino, Italy

†Talco e Grafite Val Chisone SpA, Italy

SUMMARY

The paper refers to the results of an experimental research developed at the most important Italian talc mine of Fontane. A preable series of tests confirmed the substantial absence of asbestos fibres, and the consequent exhaustivity of gravimetric samples to evaluate the particulate content in the atmosphere; on the basis of extended sampling work as performed in an experimental and in other working stopes, a correlation has been identified between the scheme of auxiliary ventilation plant at various flow rates and the dust concentration. It was also possible to show a good efficiency of the exhausting system, as compared with the blowing system, owing to a quicker removal of particles from the workplaces, to a reduction in air dispersed dust up to about 20%, and to the absence of secondary dust production and annoyance of miners. On the basis of research results in the future the exhaust ventilation system will be as much generalized as possible in the mine.

INTRODUCTION

The Fontane talc mine, located in the Germanasca valley 80km West of the city of Turin, is exploited by Talco e Grafite Val Chisone Co. The mine is one of the most important talc mines in Europe in terms of both the tonnage and the quality of talc produced (about 40000 t/y of pure white talc); for instance specifications of Extra Superiore brand quality are summarized in Figure 1.

The orebody has a typical "rosary" structure—a series of lenses en echelon—which strikes N20 W and dips towards the West at an average slope of 20°–22°.

The lenses can be large, but are extremely irregular, varying in width from a few centimeters up to 5–8 m, exceptionally to 15 m.

The footwall bedrock is a compact augen-gneiss while the hanging wall comprises greenstones and mica schists.

At present the mine is being worked in two different sections: Gianna, on the left side of Germanasca river, and Crosetto, on its right (see Figure 2).

Since 1974 the exploitation method is underhand horizontal slicing with cemented backfill, taking the ore in strips running transversely to or parallel with the orebody, with stopes of up to 8 m² cross section (Figure 3).

The primary ventilation at Crosetto section, in an experimental stope of which the described tests were carried out, is based on a fan activated exhaust system, linking the main level (1400 m over sea level with an upper one at 1500 m).

At present blind stopes ventilation, in which faces may reach a distance of more than 120 m far from the main ventilation level, sometimes proved not to be quite satisfactory, in particular with regards to air velocity (Italian mining law requires a mean air velocity of 10 cm/s in the stopes), and comfort conditions.

A common research work has been carried out by Talco e Grafite Val Chisone Co. and Mining Dept. of Technical University of Turin, to both identify a proper technique of dust measurements in the stopes of Fontane mine, and to achieve further improvements in the general environmental conditions.

DUST SAMPLING TECHNIQUE

A preliminary problem to be solved in order to organize systematic dust concentration surveys in the mine stopes was to identify a correct sampling organization, and suitable apparatus.

A more than two years long campaign, developed with battery powered Dupont P4000 samplers (flow rate 1 dm³/min., open holders for 25 mm dia.—0.8 μm pore diameter cellulose filters) has been carried out, and made possible to achieve some preliminary results. First, some mining operations were identified, during which the maximum dust production occurs, in terms of gross air concentration (see Figure 4); furthermore it was confirmed that, in this case too, a proper evaluation of workers exposure may be obtained with personal sampling devices carried by the workers: the risk of unpredictable human behaviours has shown to be very low after two months of testings.

TALCO E GRAFITE VAL CHISONE S.P.A.

TALC: EXTRA SUPERIORE

Extra Superiore Talc is a hydrous magnesium silicate, platy in structure, which meets all pharmaceutical specifications (Eur. Pharm.) and does not contain asbestos minerals (C.T.F.A. J4-1)

It is suitable for various applications where high purity and extremely platy talc is desired.

PHYSICAL DATA

Whiteness (FMY/C - Green Filter) %: 90.5	Oil Absorption (DIN 53199/ASTM D281-31) %: 32
(FMZ/C - Blue Filter) %: 89.5	
Specific Gravity (DIN 53193) g/cm ³ : 2.8	B.E.T. Surface (DIN 66131/66132) m ² /g: 4
Tapped Density (DIN 53194) kg/dm ³ : 0.79	Abrasivity (AT 1000 - 2 hours) mg: 10
Loose Density (DIN 53468) kg/dm ³ : 0.45	Hardness (Mohs) : 1

PARTICLE SIZE DISTRIBUTION

< μm	%
75	: 99.3
45	: 83.6
20	: 49.8
10	: 30.5
5	: 15.3
2	: 7.4
1	: 3.5

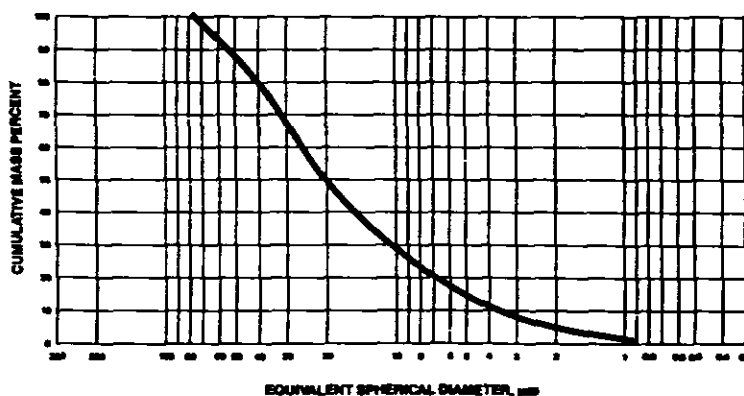

CHEMICAL DATA

SiO ₂	%: 60.1	L.O.I. (1050°C)	%: 5.3
MgO	%: 31.8	pH (DIN 53200 - 10% slurry)	: 9.3
Al ₂ O ₃	%: 1.5	Moisture (DIN 53198 - 105°C)	%: 0.2
Fe ₂ O ₃	%: 0.9	Water Solubility (DIN 53197)	%: 0.1
CaO	%: 0.4	Acid Solubles (DIN 55920)	%: 2.3

Figure 1. Specifications of Extra Superiore brand quality.

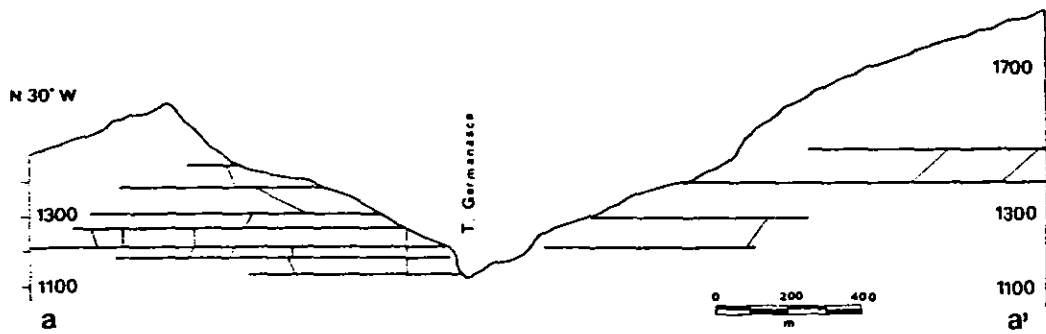
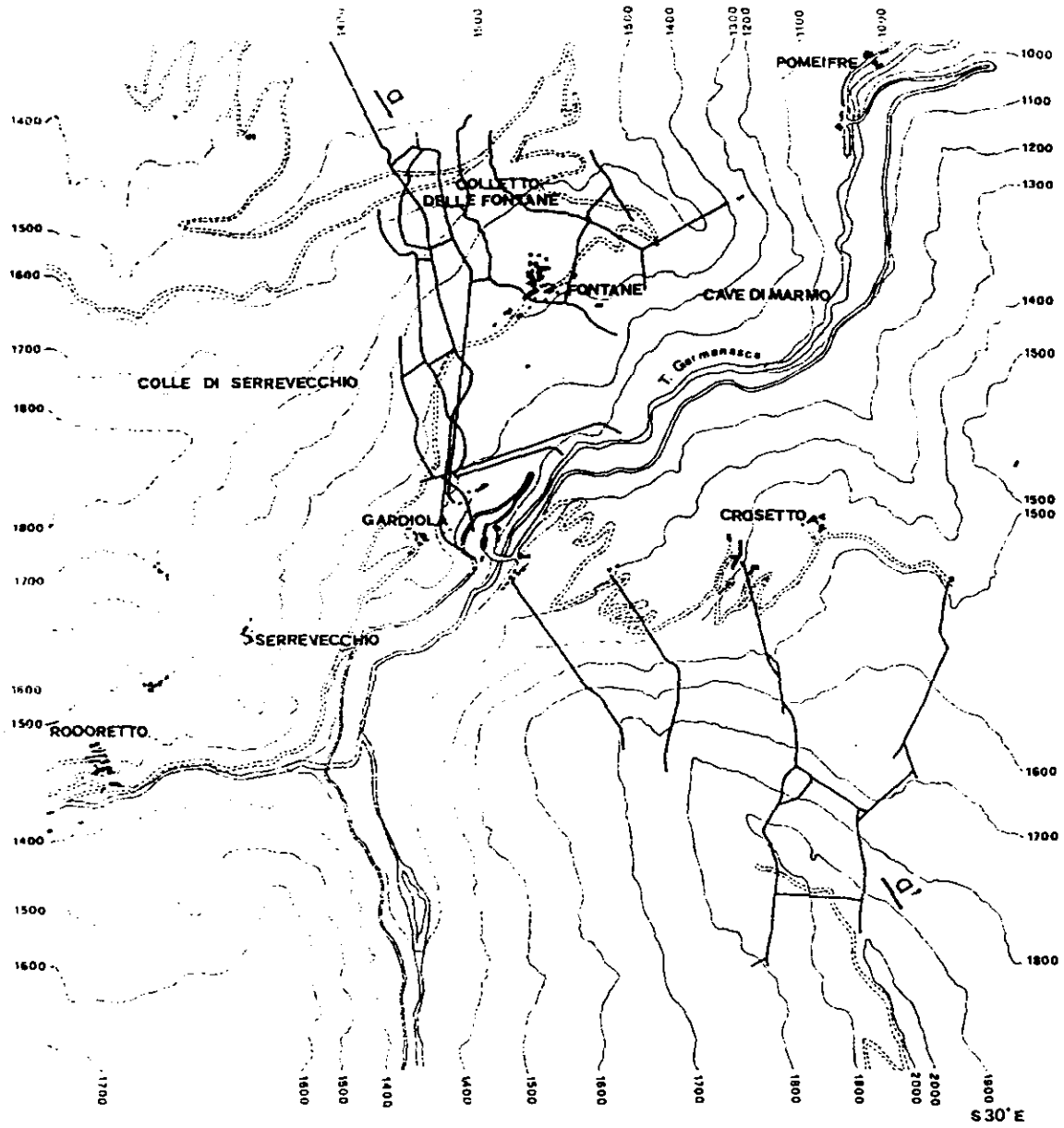

Figure 2. The Fontane talc mine, plan and section, showing the main underground levels.

At last a systematic microscope analysis on more than 200 samples from production stopes, carried out with phase contrast illumination (500x magnification), confirmed a respirable particle content of crystalline silica less than 1% (in mass).

X.R.D. analysis of samples proved the absence of asbestos minerals. Some fibrous shaped elements—from platy talc breakage—were sometimes identified, well less than 1% in number of respirable dust particles.

Owing to the shape of talc particles in respirable dust collectable in Fontane mine stopes, it has been necessary to verify the actual effectiveness of separating devices for this particular application.

In situ and laboratory tests (in a specially designed apparatus, see Figure 5) were carried on, to collect information on the performances of two different size-selectors, also in comparison with open holder samplings. The flow rates have been adjusted according to separators Constructor data, and 1 dm³/min respectively.

The results of the above mentioned tests are summarized in Table I. The 10mm nylon cyclone separator confirmed its high efficiency with reference to Respirable Particulate definitions, however it has been possible to observe a remarkably greater (but with extremely dispersed data) content of respirable particles in the "not respirable" deposit. Sometimes, moreover, in long duration samplings in stopes with high humidity degree, particle agglomeration and partial obstructions were to be feared.

Consequently, it appeared at the moment preferable to select, as the most suitable for dust sampling in Fontane mine stopes, the stainless steel shell cyclone separator, in spite of some lower separation efficiency, considered that this over-estimation may help technical improvements of the environmental conditions.

The analysis of the collected samples may properly be based on the mass determination criterium, according to International Standards, provided that the crystalline silica content and mineralogical nature of fibrous elements are periodically verified.

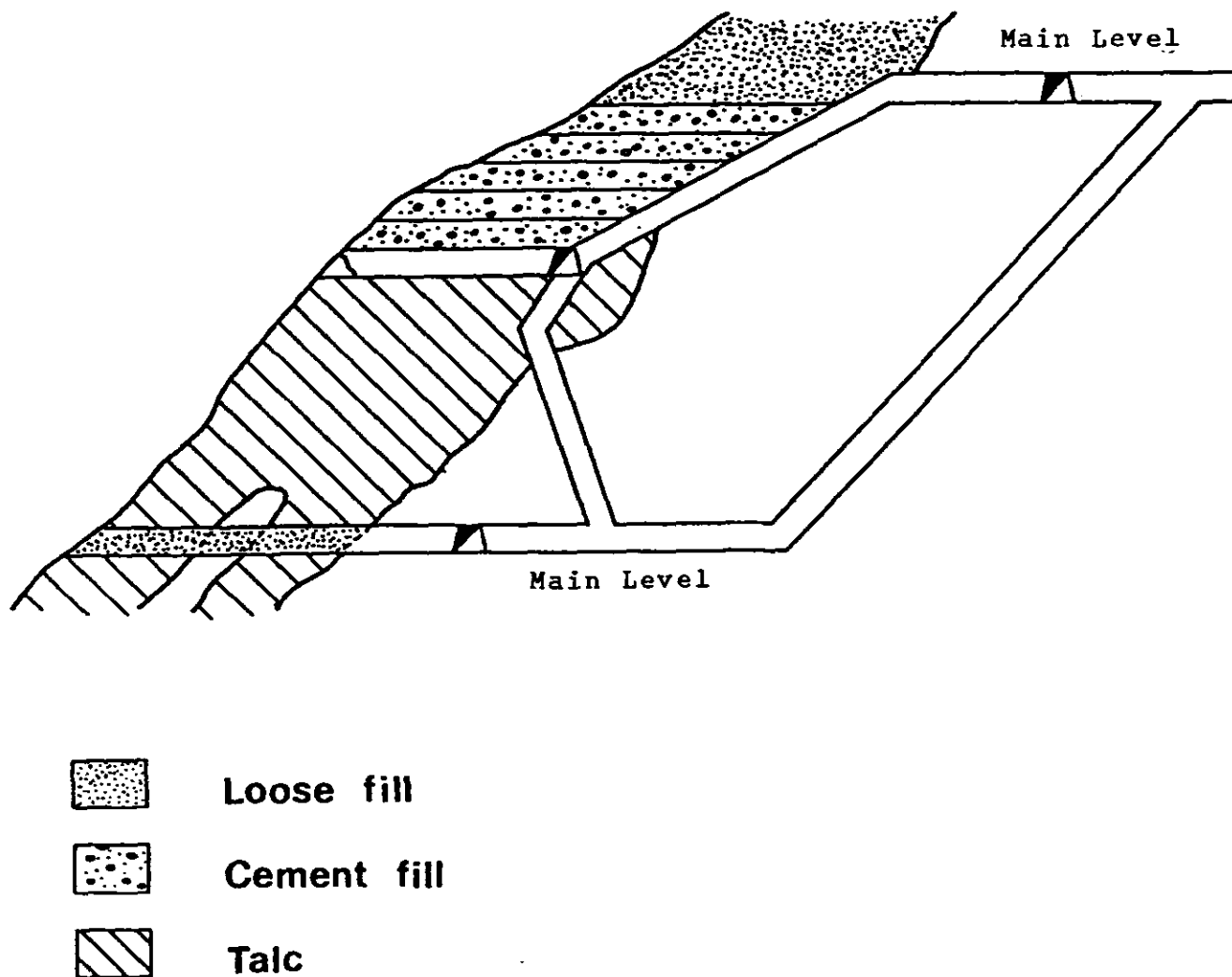

Figure 3. The mining technique employed: underhand method with cement fill.

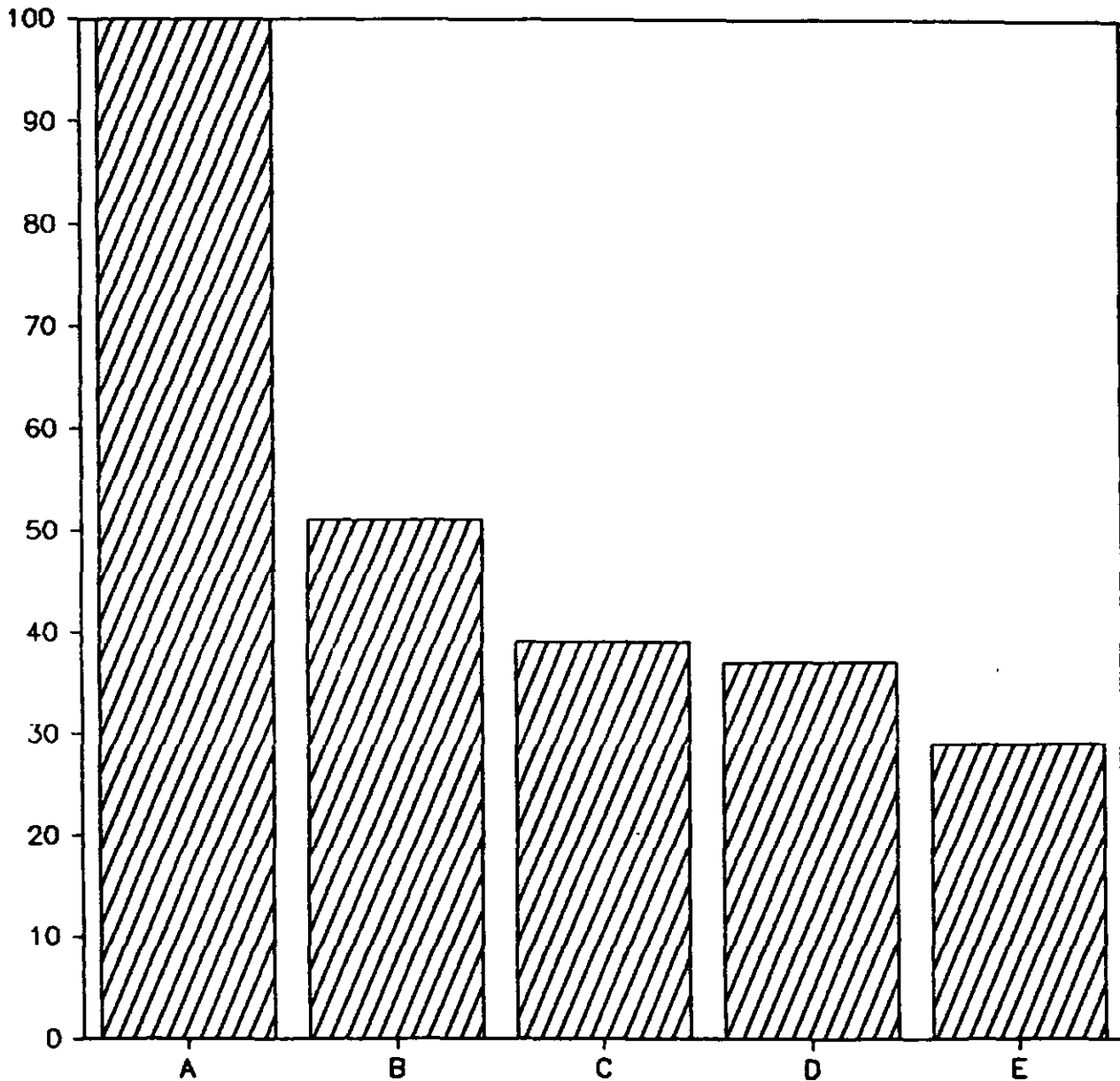

Figure 4. Comparative dust level, compared to case A:
 A—breaking with hammerpick; B—loading with compressed air shovel (on rail);
 C—loading and hauling with rubber tyred electrohydraulic equipment; D—face
 and roof cleaning; E—others (maximum).

BLOWING AND EXHAUSTING AUXILIARY VENTILATION

In order to verify the possibilities of improving the environmental conditions in the mine stopes, an experimental stope of 4 m² cross section (Crosetto, n.7, Figure 6), in which the face was at a distance of about 40 m from the main ventilation level, has been equipped with a centrifugal fan (7.5 kW) and a flexible tubing (300 mm dia.) in rubberized nylon with metal springs.

The tubing was set in such a way that it was possible to attach

it to the inlet or to the outlet of the fan.

The face end of the ventilation duct was set at a distance of 5 m from the face.

A series of tests has been carried on at various flow rates, obtained by properly positioning the regulation metal brattice of the fan, both in exhausting and in blowing configuration.

Dust concentration, air mean velocity and microclimate parameters at the face were recorded, and W.B.G.T. comfort index calculated for each plant regulation. Moreover explosive

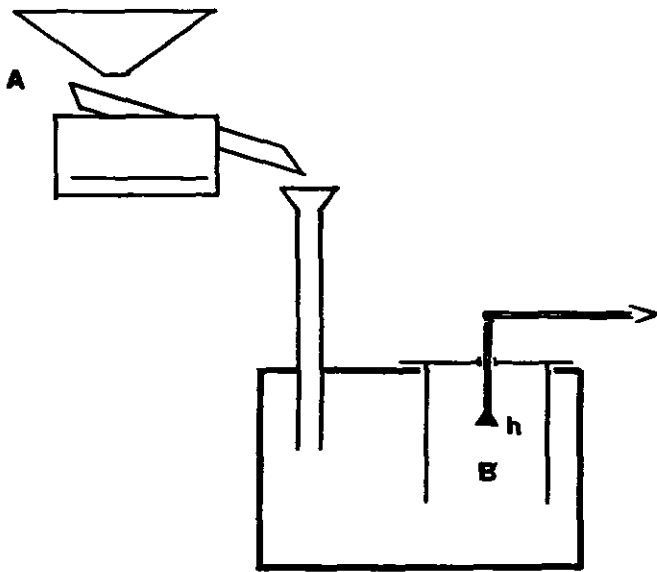

Figure 5. Layout of the apparatus used in laboratory tests (schematic): A—hopper and vibrating feeder; B—sampling room; h—sampling holders.

fumes concentration (NO_x and CO) were systematically measured (with Drager test equipment) 15 minutes before the restarting of work (two hours after the blast).

For each test also dust concentration in the access way to the stope was measured, at a distance of about 20 m from the face.

Table II summarizes the most significant results of the above mentioned tests. As to thermal and humidity conditions it was observed that, in the period of testing, the mean temperatures resulted of 7–10°C and 10–14°C respectively in the main level and at the face, and the relative humidity in both sites was near to 100%; W.B.G.T. values at the face ranged from 10 to 14°C.

On the basis of the achieved results it must be observed in particular that dust concentration and comfort conditions at the face appear clearly not acceptable with the maximum flow rate in blowing plant configuration, due to the excessive air velocity.

Taken for granted that noxious fumes concentration is not a problem in any case, it may be assumed that satisfying environmental conditions at the face can be achieved both with a blowing scheme as in case 2, and with an exhausting scheme as in case 1.

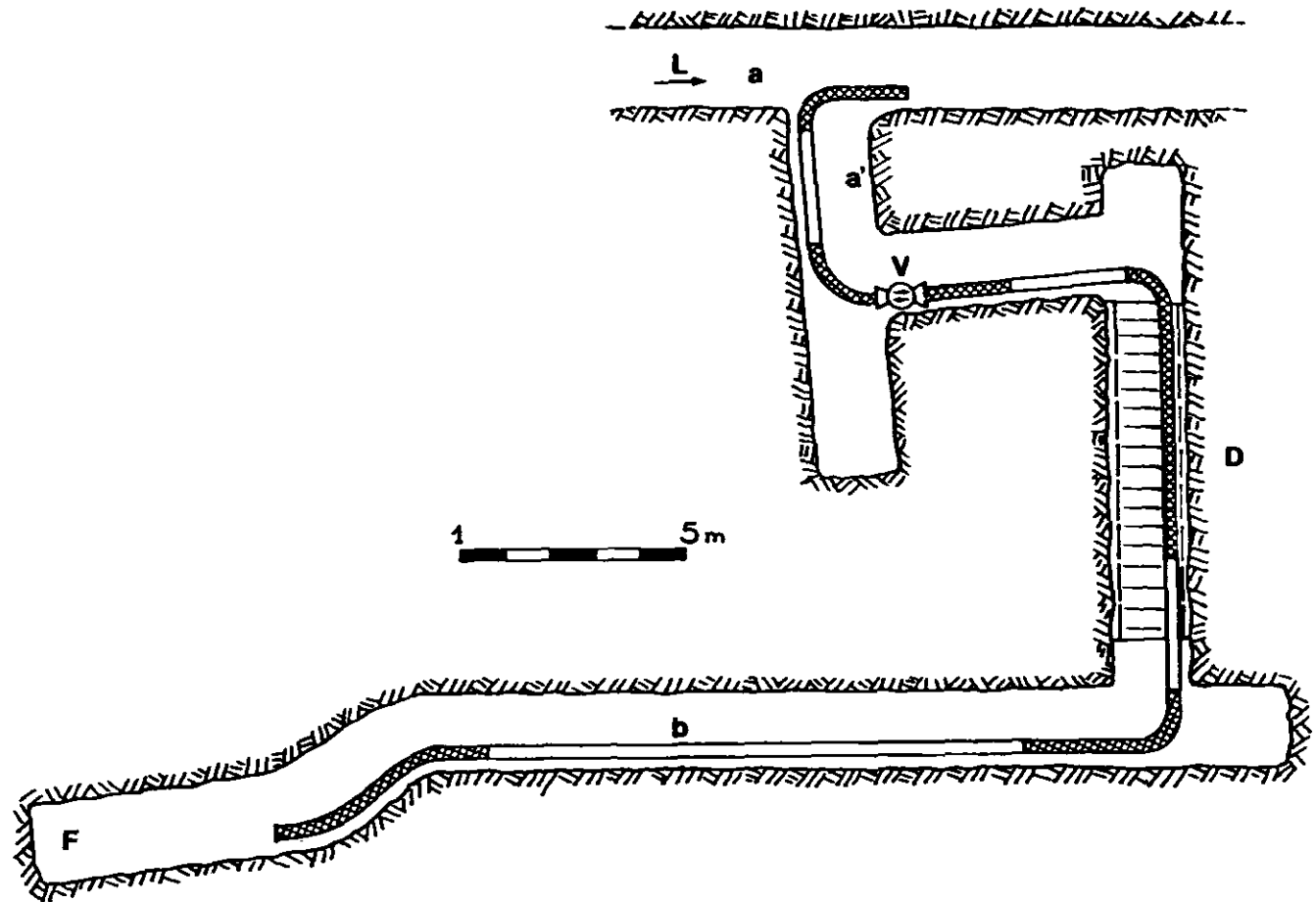

Figure 6. Diagram of stope n.7, Crosetto, where the tests were carried out: L—main level; F—stope face; D—slope; a, a', b, F—sites of measures.

Table I
 Mean Size Distribution (Number of Particles) as Measured
 in the Samples Collected with Different Apparatus:
 A—Open Holder; B—Stainless Steel Cylindrical Shell Cyclone;
 C—10 mm Nylon Cyclone

	particle size (μm)	A (2)	B (3)	C (3)
Laboratory tests (1)	< 5	80.1	86.1	90.1
	5 - 10	17.4	13.0	9.7
	10 - 20	2.2	0.8	0.2
	> 20	0.3	----	----
	Dmax(4)	25	20	15
In-stope tests	< 5	93.5	97.1	98.1
	5 - 10	4.2	2.4	1.9
	10 - 20	1.8	0.4	----
	> 20	0.5	0.1	----
	Dmax(4)	60	30	15

- (1) Performed on commercial product (0-80 μm)
 (2) Flow rate 1 dm³/min.
 (3) Flow rate according to Constructor data.
 (4) Exceptional.

Table II
Results of the Tests Carried on at Crosetto n.7 Experimental Stope

	flow rate m ³ /s	mean air velocity (stope) m/s	max air velocity (stope) m/s (*)	t _{max} -t _{min} in stope °C	t _{max} (st)- t(lev) °C	t _m (st.acc.) -t(lev) °C	respirable dust conc. (**) mg/m ³
exhausting system							
case 1	0.44	0.12	0.18	1	3	0	0.45
case 2	0.38	0.10	0.12	0	3	0	1.15
case 3	0.35	0.09	0.09	0	3	0	2.10
blowing system							
case 1	0.57	0.15	0.33	2	3	3	2.30
case 2	0.45	0.12	0.15	3	3	3	0.50
case 3	0.36	0.09	0.09	3	3	3	2.05

* Italian mining law ref. > 0.10 m/s

** samples collected during breaking with hammerpick.

The exhausting system—in the above mentioned conditions—has proved to be more efficient in particular with regards to comfort conditions in stopes where the temperature is remarkably warmer than in the ventilation level: annoying localized temperature variations are avoided both at the face and at the beginning of the stope access way from the main level.

Moreover, a lowering of dust concentration along the stope access way (about 20%) has been observed at equal air velocities in the different ventilation systems, even if in any case the absolute values were far from suggested T.L.V. for talc dusts.

On the basis of the previous considerations the use of the exhaust ventilation system will in future be generalized in the stopes with important differences between stope and main stream air temperature, while blowing system can be maintained (for economic and technical reasons, such as lower

costs of tubing and installation) where this problem does not arise.

A research work has been undertaken to design a diffusive tubing outlet to be suggested for blowing system, to avoid a discomfortable localized air stream at the face.

CONCLUSIONS

A proper dust sampling technique has been tested, specially fitted for Fontane talc mine.

The results of tests on auxiliary ventilation systems made possible to identify the main plant features that may give good environmental conditions and stressed that, in particular where an important difference between face and level air flow temperature arises, the exhausting ventilation system must be preferred.

Research work is now being carried on to achieve further improvements.

A RESPIRABLE DUST SURVEY OF VARIOUS METALLIFEROUS MINE SITES IN QUEENSLAND, AUSTRALIA

S.L. BELL • P.J. Lynch

Safety in Mines Testing and Research Station, 2 Smith Street, Redbank, Queensland, 4301, Australia

INTRODUCTION

This paper describes the current development of dust surveillance and respirable quartz monitoring in a range of metalliferous mines in Queensland, Australia. Gold mines and quarries are predominant in the study, although sand, nickel, limestone and bauxite mines are also covered. A Fourier Transform Infra-Red (FTIR) method was developed to measure quartz content in respirable dust samples. The matrix difficulties which are present with such a wide range of sample sources have been overcome using a specific interferent reduction program applicable to any type of material.

BACKGROUND

This program of mine surveillance began as recently as 1986 when the Safety in Mines Testing and Research Station (SIMTARS) was established to provide, amongst other things, an occupational hygiene service encompassing all types of Queensland mining operations. SIMTARS is also involved in electrical and flameproof testing of equipment destined for use in underground coal mining and other potentially hazardous areas. From its extensive, special gas analysis service, SIMTARS also provides an emergency gas analysis service for coal mines in event of a mine disaster.

While the workers in Queensland coal mines are sampled on a regular basis for respirable dust and quartz by officers attached to the Coal Mines Inspectorate (GRANTHAM and BELL, 1987), no regular systematic respirable dust sampling has ever been carried out at Queensland metalliferous mines. The reasons for this include the diversity of mining types and the geographical separation of mine sites in a very large state. Furthermore, many of the mining operations are small and employ few personnel, limiting the feasibility to survey these small mining operations in the past.

In the absence of any data on these mines, the opening gambit was to visit only the major sites to cover the largest concentration of workers and processes, with a few smaller sites included to determine if size affected dust exposure or dust control in any way. From these data, a suitable inspection frequency could be determined and immediate problem areas could be targeted for investigation and improvement. In the longer term, the information can be used in an epidemiological review of dust disease amongst these mining populations.

In addition to the respirable dust monitoring, noise measurements were also made. Collection and processing of the

samples was undertaken by the small (5 member) hygiene group. The sampling technique, adapted where necessary to meet the commitments of mining schedules, has followed the Australian Standard 2985 1987 (Workplace Atmospheres—Method for Sampling and Gravimetric Determination of Respirable Dust), itself based on the familiar MDHS 14 of the UK Health and Safety Executive.

METHODOLOGY

Respirable dust measurements were carried out using Dupont P2500 sampling pumps entrained with Casella 37 mm cyclone elutriators. The dust samples collected were analysed for free silica using a Fourier Transform Infrared technique which utilizes computer controlled spectral subtraction of interfering minerals.

Previous techniques in respirable quartz analysis of dust samples containing interfering substances required computer subtraction of known interferents from the sample mixture. Dust samples obtained from mining environments often have interfering minerals which are difficult or impractical to analyse. Using computer software available with modern FTIR's (e.g. Perkin Elmer Model 1750), quartz in mixtures can be readily evaluated without knowing the exact nature of interfering substances. By spectrally subtracting pure quartz (Australian Standard 9950) from the sample mixture a spectrum of the interferent is generated. This interferent spectrum can then be subtracted from the mixture leaving a spectrum of quartz free from interference (see Figure 1). Viability of the resulting quartz spectrum can be determined by either the ratio of the peak heights in the doublet and/or the ratio of the peak heights in the doublet to the minor 690 cm^{-1} peak. While this interference free quartz spectrum can be quantitated using presently accepted methods (e.g. standard regression line and peak heights), it is not necessary since a user generated normalization factor can be used to calculate the quartz content directly. The theory is described briefly below.

Both the mixture and the pure quartz spectra are converted to absorbance. The difference between ordinate values of the two spectra at each data point is determined. These ordinate difference values represent the interferent spectrum and can be represented by

$$d_3 = d_1 - (d_2 \times f)$$

Where d_3 = ordinate values of the difference spectrum or in this case the interfering components of the mixture.

d_1 = ordinate values of the mixture.

d_2 = ordinate values of the pure quartz

f = normalization factor applied to the quartz std. spectrum to make it equal to the quartz component of the mixture.

When the quartz standard spectrum is subtracted from the mixture spectrum, only the interferent spectrum should remain. The true normalization factor is selected interactively by manipulating the difference (i.e. interferent) spectrum. The factor is correctly selected when all contributions from the quartz in the interferent spectrum are reduced to zero. In other words the standard quartz absorbance values are made the same as the absorbance contributed by quartz from the sample mixture. The content of quartz can be readily calculated by multiplying the known weight of quartz in the standard (W_q) by the normalization factor, f : This is

$$\text{Amount of quartz in mixture} = W_q \times f$$

Validation of this method is currently in progress and involves evaluating known percentages of quartz in mixtures prepared at SIMTARS followed by interlaboratory testing of standard samples.

DISCUSSION

All the dust data obtained was incorporated in a data base constructed specifically for this purpose. The results are presented in Tables I—VII. Almost 700 personal respirable dust samples were taken over a 14 month period and of those some 150 were analyzed for respirable quartz content. A significant number of mine types (limestone, nickel, bentonite etc) did not have a quartz problem and are not represented in the quartz histograms.

The present Threshold Limit Value (TLV) for respirable quartz is 0.2 mg/m^3 (although it will soon be lowered to 0.1 mg/m^3). This TLV is an Australian variation of the current ACGIH levels and results from a recommendation made by the National Health and Medical Research Council (NH & MRC, 1978). Epidemiological evidence in the Australian context has not yet been able to establish the validity of the NH&MRC recommended levels. Histogram representations of the data indicate that approximately 20% of occupations surveyed fail the respirable quartz TLV of 0.2 mg/m^3 while over 60% will fail when the level is lowered to 0.1 mg/m^3 .

The situation with quarries and gold mines is generally worse with the figures being 40%/90% and 30%/50% respectively. In practice there is concern since in 92% of the personnel

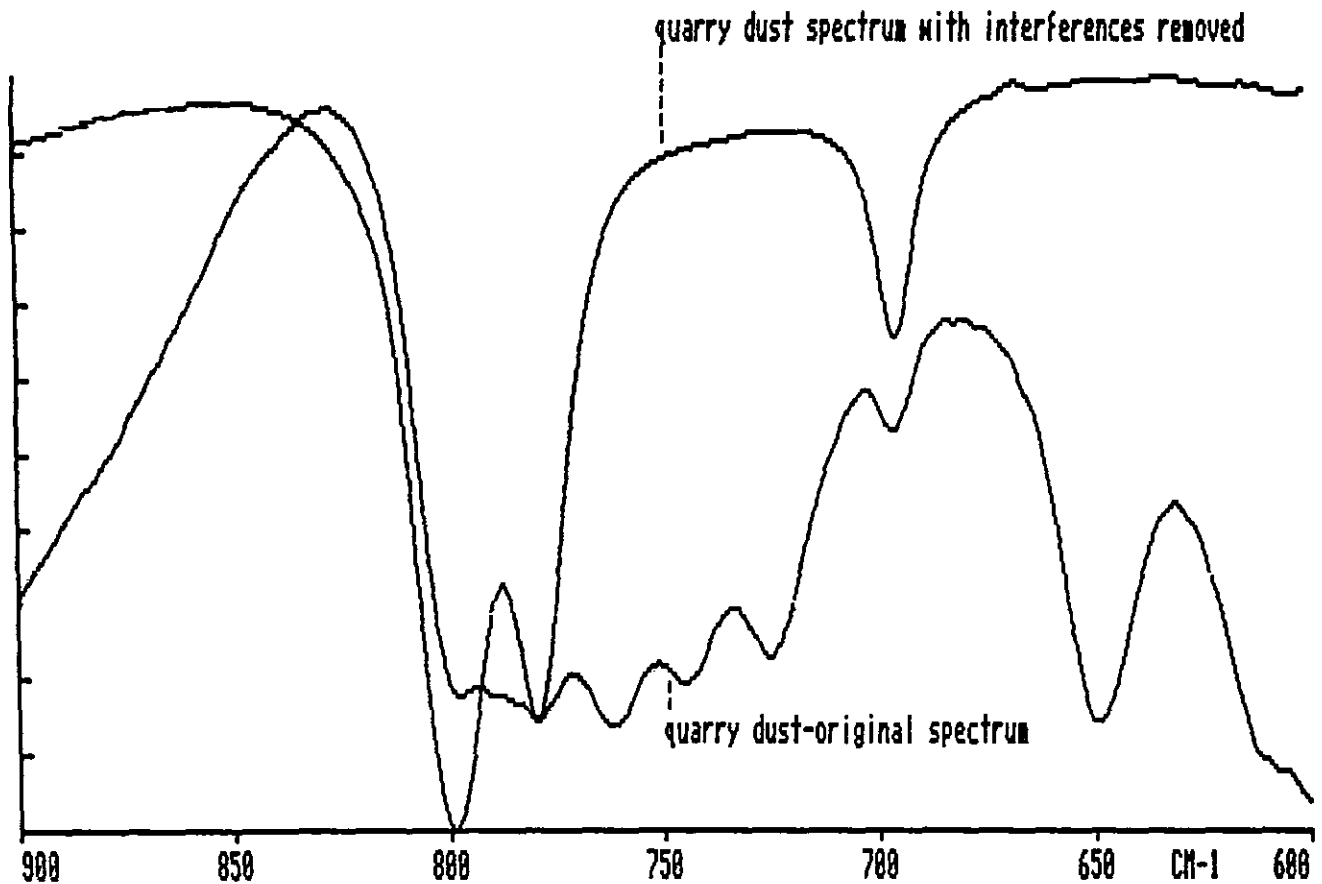
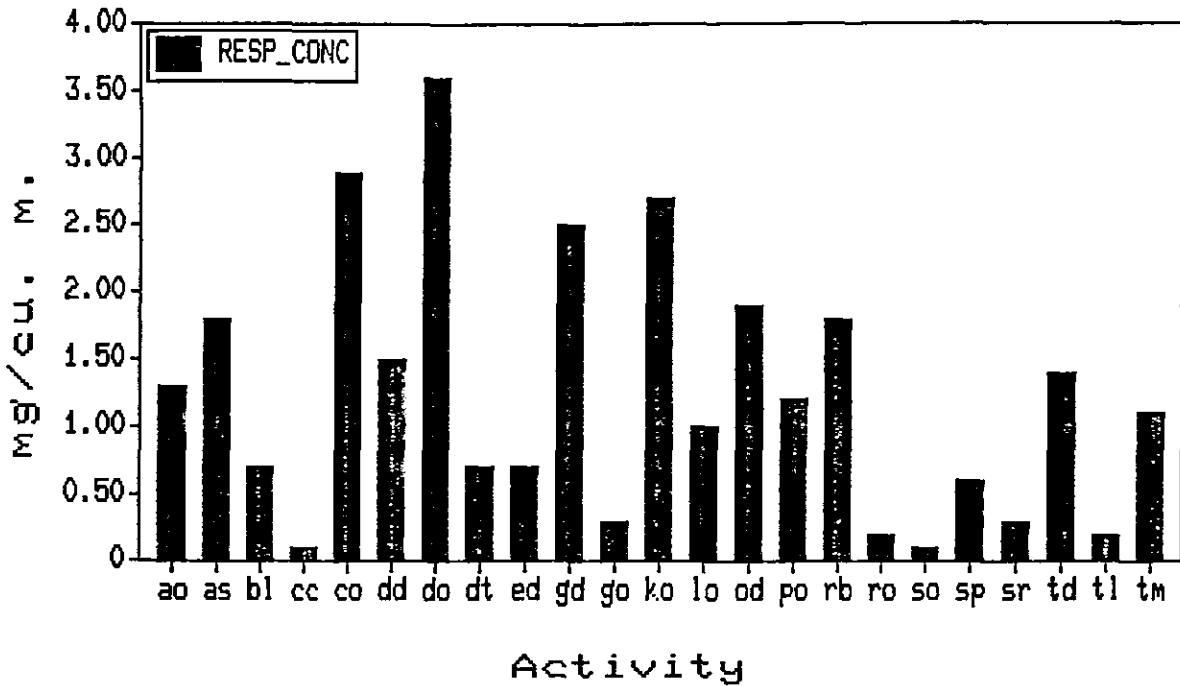

Figure 1.

Table I
Average Respirable Dust Concentration by Activity
(All Metalliferous Mines Surveyed)



- Activity**
- | | | | | |
|-----------------------|------------------------|------------------------|-------------------------|-----------------------|
| ao - Agglomerator Op | as - Assayer/Sampler | bl - Blaster | cc - Conveyor Attendant | co - Crusher Operator |
| dd - Dozer Driver | do - Dragline Operator | dt - Dump Truck Driver | ed - Excavator Driver | gd - General Duties |
| go - General Operator | ko - Kiln Operator | lo - Loader Oper. | od - Overburden Driller | po - Plant Operator |
| rb - Rock Breaker | ro - Roller Operator | so - Saw Operator | sp - Spotter | sr - Scraper Operator |
| td - Truck Driver | tl - Train Loader | tm - Tradesman | | |

Table II
Average Free Silica Concentration by Activity
(All Metalliferous Mines Surveyed)

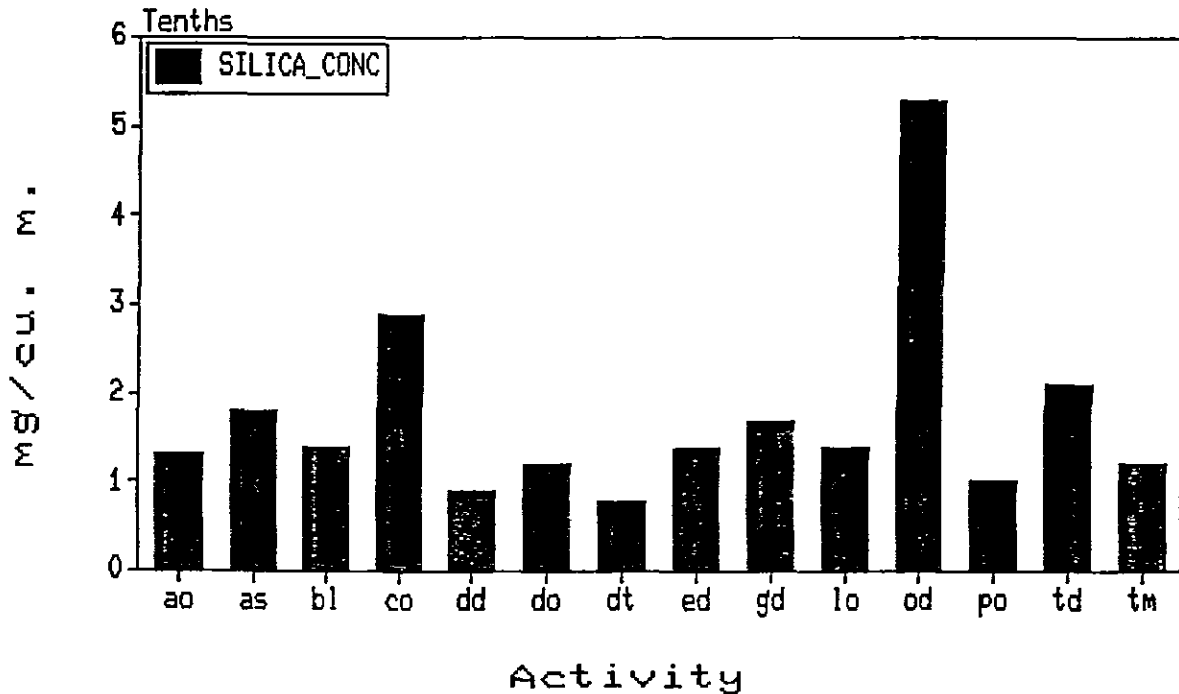

Table III
Average Respirable Dust Concentration by Activity
(All Gold Mines Surveyed)

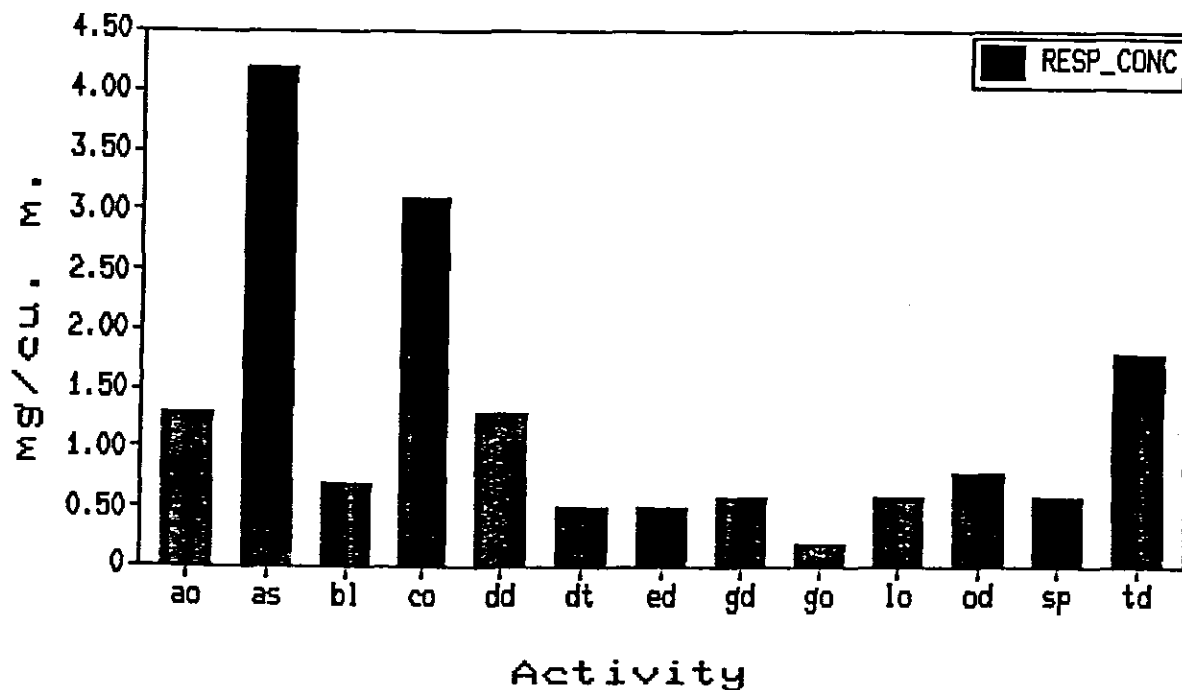

Table IV
Average Free Silica Concentration by Activity
(All Gold Mines Surveyed)

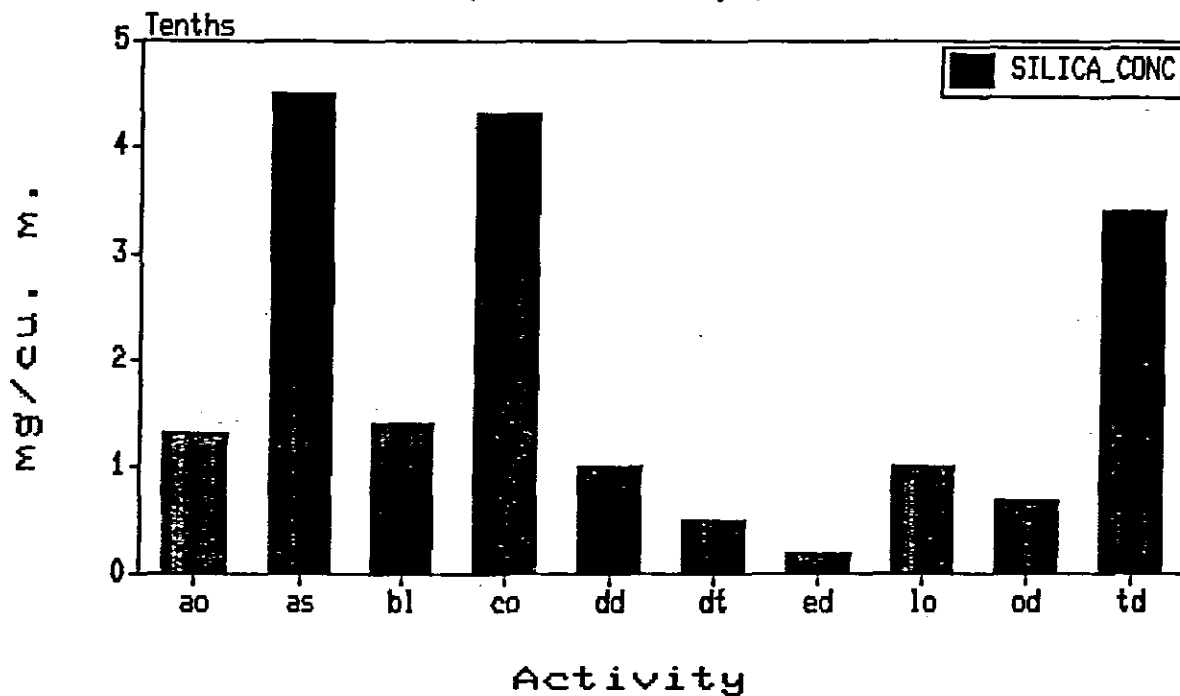

Table V
Average Respirable Dust Concentration by Activity
(All Quarries Surveyed)

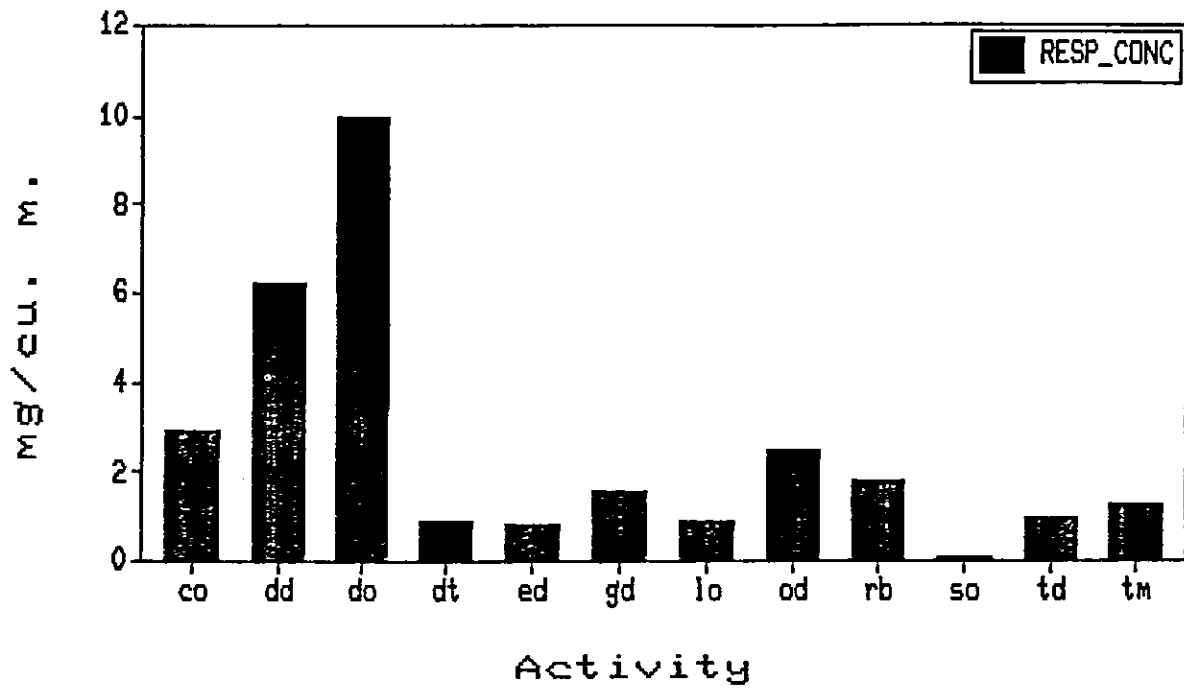

Table VI
Average Free Silica Concentration by Activity
(All Quarries Surveyed)

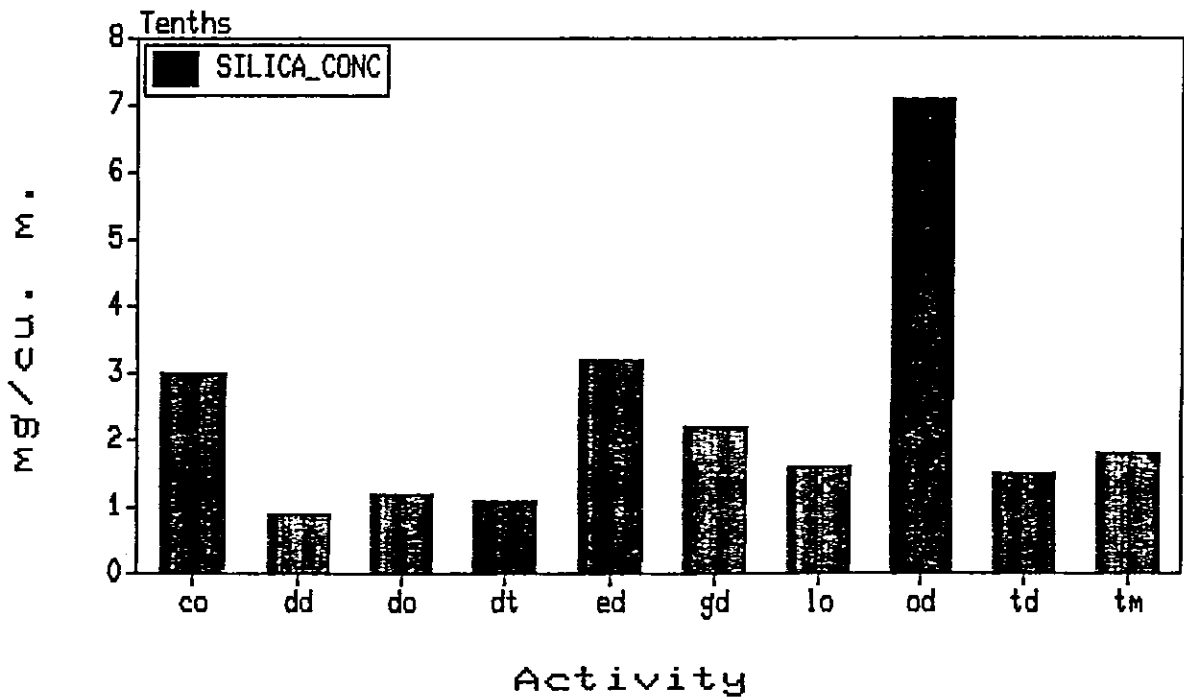
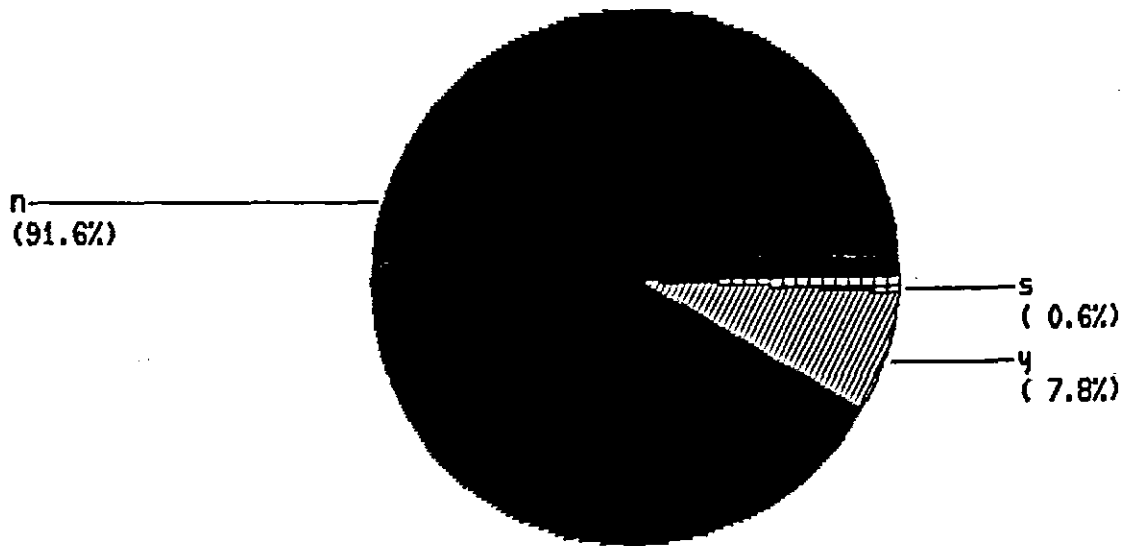

Table VII
Mask Usage
(All Metalliferous Mines Surveyed)



sampled, no respiratory protection was employed. This problem is now being addressed by SIMTARS with increased quartz monitoring to study quartz exposure by occupation by mine.

This survey represents the establishment of base respirable dust exposure levels in the Metalliferous Mining Industry which is in an expanding raw material resource economy. Compared with other hardrock mines within Queensland which have had the benefit of environmental and radiological surveys, a relatively greater problem exists in these more recently surveyed mines.

Pertinent data is being channelled to the regulating (Inspectorial) group within the Queensland Department of Mines. Some positive progress has been made in recent months with

the installation of dust extraction systems on an errant crusher and several air track drilling systems. Impending occupational health legislative changes which will bring Queensland in line with the other Australian states should result in a more committed management safety philosophy.

Dust surveys of this nature will be carried out on an on-going basis. This information base will be continually updated and a series of annual reports will be produced which will demonstrate the efficacy (or otherwise) of this nascent hygiene management program.

REFERENCES

1. Grantham, D.L., Bell, S.L.: A decades experience with personal dust monitoring in Queensland's coal mines. *Australian Journal of Coal Mining Technology and Research* 1987; 18:1-20.

THE ACHIEVEMENTS IN DUST-CONTROL AND DUSTPROOF MEASURES TAKEN SINCE THE FOUNDING OF THE PEOPLE'S REPUBLIC OF CHINA

QIUHUA QIN Eng. B.

Department of Economy, Technology and Labour Protection of the All-China Federation of Trade Unions

Mr. Chairman and fellow delegates,

At the invitation of the International Labour Office, the Chinese trade union has been offered the opportunity to be able to attend the VIIth International Pneumoconioses Conference. Therefore, I would like first of all to thank the ILO for its kind invitation. It is my wish, Mr. Chairman, to address the Conference on our efforts to control dust in China for the purpose of promoting mutual understanding, exchanging information and experience in the course of this Conference.

THE ACHIEVEMENTS MADE IN CHINA IN THE DUST-CONTROL WORK

With regard to dust harm affecting our country, we insist on priorities given to the preventive measures against dust harm and apply the principle of three-stage prevention namely, at the first stage, to eliminate dust harm and control dust sources; at the second stage, to provide check-up regularly to ensure the early diagnosis of diseases; at the third stage, to make sure that diseases are controlled and treated at a possible early stage. The stress is placed upon the first stage prevention when applying the above-mentioned principle.

To apply this principle, the state, with the active participation of our trade unions, has formulated in the last thirty-odd years a series of laws, decrees, instruments and standards. In 1956, "The Safety and Health Regulations at Workplaces" was promulgated and applied following which, "The Resolution on the Prevention of Silicon Dust Hazards at Workplaces" was published. Then "101-56 Standard"—health design standards on dust concentration—was set by the state, based upon which the maximum allowable concentration (MAC) of the dust is set to $2\text{mg}/\text{m}^3$ if free silicon dioxide content is greater than ten percent in the dust and MAC is set to $10\text{mg}/\text{m}^3$ if less than ten percent. In 1958, the relevant departments issued "The Provisional Regulations on the Technological Measures Against Silicon Dust Hazards at Workplaces," illustrating demands on the practice to control dust. In 1962, the state formally promulgated "The Health Design Standards on the Industrial Enterprises," prescribing in detail the provisions on ventilation and dust sources control at the workshops. In 1979, that Standard was revised. In 1963, "The Managerial Measures against Silicon Dust Hazard" was put into practice on a trial basis in our country, thus making our work on dust-control even more systematic. Therefore, these laws, decrees and standards have constituted a very important guarantee for the prevention and treatment of pneumoconiosis. Particularly, in recent years, the State

Council, taking into account new problems arising from the economic reform of our country, has made "the Decision on Strengthening the Work of Preventing Dust and Toxicant and Pneumoconiosis," thus pushing the dust-control work further.

Positive steps have been taken in China actively by various industries, enterprises and relevant departments in accordance with the state's laws, decrees and regulations. Three nationwide working conferences on dust-control were held in 1957, 1962 and 1985 respectively, summarizing and spreading afterwards the experience on dust-control throughout the country. In the field of dust-control, we focus our attention on our own efforts by taking such comprehensive measures against dust as: to transform old enterprises; to improve technology and regenerate equipment. Of many years in China, we have found out a number of ways of our own to prevent and treat pneumoconiosis, i.e. mechanical ventilation; wet-operation; dust-sealing; personal protection; maintenance and management of dustproof installations; technological innovation and improvement of technology; regular check-up for the workers exposed to dust; propaganda and education on dust-control. This comprehensive measure against dust has been proved by the fact to be a successful experience suitable to China's situation. And we have already achieved tangible results. According to the statistics collected from 16 key refractory factories, the average working age to acquire silicosis in the 1950s was 7.55 years; in the 1960s 14.52 years; in the 1970s 20.73 years; at the early stage of the 1980s it was 25.89 years. There has been a big reduction in the dust concentration in factories. Various steps have been taken to control dust in all industries in accordance with their own industrial features and experience. Take coal mining for example. A whole series of effective measures against dust has already been taken as follows:

1. Wet-drilling;
2. Coal seam infusion to increase moisture content;
3. Making use of "water stemming" i.e. to suppress dust by incompressibility and vaporization of water at exposure;
4. Spraying to minimize dust in the course of transportation and blast loading;
5. Mechanical ventilation, dust suppression by water mist and purification of airflow;
6. Replacing dry-mix shotcreting with wet-mix shotcreting;
7. Cleaning the fallen dust in the tunnels, on the rock sidewalls, support and road so as to prevent dust from floating again.

Sucun Coalmine of the Xinwen Coal Mining Management Bureau in Shandong province, well-known for its dust-control

work throughout our country, has taken nothing but the above-mentioned measures. By so doing, up to now, none of the miners employed in 1959 has suffered from pneumoconiosis.

In our country, great importance has been attached to training and scientific research in this respect. So far there are more than twenty universities and colleges where departments or specialities of safety and health have been set up; there are thirty-one research institutions with more than four thousand research fellows all over China.

THE PRESENT COUNTER-MEASURES AGAINST DUST IN CHINA AND THE ROLE OF THE TRADE UNIONS

Being a developing country, in the last thirty-odd years since the founding of the People's Republic of China, tremendous work has been done in the field of prevention and treatment of pneumoconiosis and fairly great progress made. However, as is known, the occurrence of pneumoconiosis is closely related to the development of the industrial modernization. China is now undergoing the primary stage of socialism under which, except some modern industries, a large number of our industries still remain quite backward, falling behind those modern levels for several decades or even a hundred years. In recent years, there has been a big boom of rural enterprises. The mode of production in most of those rural enterprises is fairly backward. Apart from that, our management and technical levels on dust-control for the time being remain quite backward on the one hand, and on the other, the level of science, technology and culture of our workers as a whole is not high enough. This is the situation in our country under which dust harm still remains very serious and pneumoconiosis can not be controlled yet. Therefore, we are still faced with a very arduous task. I think that almost all the developed countries in the process of their industrialization have gone through this dust-harm stricken period, longer or shorter, respectively. And this seems to be one of the common features of all the countries to prevent and treat pneumoconiosis. The crux of the problem lies in how we should, proceeding from our own situation, draw lessons from other countries so as to shorten this dust-harm stricken period.

- First, the government has promulgated "The Regulations on the Prevention and Treatment of Pneumoconiosis" and inspects the application of the Regulations in enterprises of different economic forms;
- Second, it is stipulated by our government that for the newly-built, extended, rebuilt, on-going projects or those projects introduced from abroad, the dustproof installations must be designed, constructed and operated simultaneously with the principal part of those projects mentioned above. The state departments responsible for labour, health and environment protection as well as the trade unions have the rights to examine, check and approve the projects. Without the signatures of the above-mentioned organizations, the projects can never be put into operation, thus to ensure that new dust sources will never be produced again;
- Third, a great importance is attached to the research on the dust-free or dust-reducing techniques as well as new anti-dust technique. In the course of our Seven-Five-Year plan, the state has allocated special funds to place the item of occupational dust-harm control, prevention and treatment

techniques into the state target projects of science and technology, thus making efforts to resolve completely the problem of dust hazards;

- Fourth, it is necessary to enforce macro-control by the state over the work of preventing dust, the management of enterprises and guidance to the industries and to carry out training on dust-control techniques for the leaders at different levels and workers as a whole for the purpose of enhancing their awareness of preventing dust and the abilities to protect oneself.

As far as our work on occupational safety and health is concerned, the system of combining state inspection, management by enterprises and industries and trade union supervision is practised. Therefore, the trade unions have important roles to play in the dust-control mainly as follows:

1. To participate, representing the interests of their members and workers, in the studies and formulation of laws and decrees related to them.
2. To take part in the procedure of design, construction and operation of the anti-dust installations related simultaneously with the principal part of the projects and to supervise the management of enterprises to bring the dust under the control in a well-planned way and to draw and use funds for dust-control purposes in accordance with the regulations.
3. To organize and mobilize workers and trade union members to carry out activities of technical cooperation so as to pool the wisdom and efforts of everyone involved to control dust.
4. To exercise mass supervision to raise criticism and constructive suggestions over those enterprises with dust hazards problems. A deadline is imposed by trade unions to the settlement of the dust problem and workers and staff members will be organized and supported by the trade unions if necessary to refuse to work under serious dust-harm stricken conditions of their workplaces.
5. To carry out an extensive education and propaganda activities among the workers and trade union members.
6. To strengthen cooperations and exchanges with the ILO/CIS and all the countries the world over, learning from their advanced experience.

At present, the All-China Federation of Trade Unions is making positive efforts to prevent pneumoconiosis. Last year, a general survey was carried out in the dust-stricken enterprises from all 29 provinces, municipalities autonomous regions except Taiwan province of our country. In addition, a major analysis was made to the 125 workplaces where dust hazards remained serious still. As a result, the foundation has been laid to better represent and safeguard the interests and rights of the workers and staff members.

Mr. Chairman and fellow delegates,

I sincerely wish that through this Conference we will be able to strengthen the exchanges and cooperations between China and all the countries the world over, and at same time to obtain useful experience and measures of other countries so as to speed up the work to prevent and treat pneumoconiosis in my country.

Thank you Mr. Chairman.

RISK ASSESSMENT OF PULMONARY EXPOSURE TO RESPIRABLE DUST WHILE WEARING DUST RESPIRATOR UNDER SIMULATED WORK CONDITIONS

BEHZAD S. SAMIMI, MSPH, Ph.D., CIH

Division of Occupational and Environmental Health
Graduate School of Public Health
San Diego State University
San Diego, CA 92182-0405, USA

INTRODUCTION

One of the most serious problems influencing the effectiveness of respiratory protection in the workplace is the degree of fitness between worker's face and respirator mask. This problem has been the focus of several investigators, particularly during the past decade.^{1,2,5-7,9-13} In spite of significant advancement in development of numerous types of respirator masks, difficulties are still encountered with respect to the ability of worker to obtain an efficient face seal with the mask of a "tight-fitting respirator." Despite the requirements for thorough qualitative and/or quantitative fit testing of tight-fitting respirators on workers in order to select the best fitted respirator mask, under actual working conditions the degree of assurance as to (1) how long a respirator mask will remain fit, (2) what factors affect the face-seal efficiency the most, and (3) what would be the potential exposure risk involved, are still uncertain. In addition to facial hair and morphology, which have been studied by several investigators in the past, factors such as repeated and prolonged head and body motion, rate of respiratory ventilation, respirator strap tension, temperature and humidity, etc. may affect the respirator fit resulting in increased exposure risk to air contaminants.

In our laboratory, we have developed a unique automated motion and breathing system that utilizes NIOSH-adopted dummy heads. These dummy heads have been used by NIOSH and other investigators for respirator bench test.

The purpose of this attempt was to develop a respirator testing system that simulates the actual working conditions. The prime objectives were: (1) to test the integrity of respirator masks, (2) to study the effects of dynamic factors that affect the respirator mask face seal such as head and body motion as well as breathing rate and frequency. Other factors that may also affect respirator seal, such as strap tension, temperature and humidity, can also be studied with this system.

INSTRUMENTS AND METHODS

System Components

The experimental system consists of a dummy, referred to as "Dusty", equipped with automated motion and breathing system. Dusty is installed inside a 1000-liter inhalation

chamber and is connected to the motion and breathing systems outside the chamber by means of cables and tubings. The major components of the system are described below:

The chamber. The chamber is equipped with gas and vapor generation systems and a Wright dust feeder. Other commonly used aerosol systems such as DOP, mineral oil or salt aerosol can also be used to generate the desired concentration of aerosol. The aerosol concentration within the chamber is monitored by means of a light-scattering particulate counter. In case of use of gas or vapor for experiment, the concentration can be continuously monitored by means of an infrared gas spectrophotometer and strip chart recorder. The chamber is also equipped with a dynamic airflow system and necessary gauges for temperature, pressure and airflow control. An electrostatic precipitator followed by an absolute filter, continuously cleans the chamber air from air contaminants before discharging it to the environment. (Figure 1)

Human-form dummy (Dusty). Dusty comes in three different sizes: small, medium and large for use with various size respirator masks. Dusty's face is made out of soft and flexible plastic and approximates normal shape of human face. Similar dummies, as stated earlier, have been used by NIOSH Respiratory Research Section in Morgantown, WV, for primarily Bench Test.² (Figure 2)

Motor drive/indexers. The 3180-P1 Motor Drive/Indexers used in this system are line-operated, energy efficient motor drive modules. An integral power supply provides the necessary DC voltages required to operate the indexer and drive. The indexer/drive modules are capable of driving stepping motors allowing a wide range of functions. The indexers are also used for memory storage up to 400 lines of program in non-volatile memory.³

There are three drive indexers in this system: A, B and C. Each drive/indexer controls one motion of the dummy in two opposite directions. Drive/indexer A also controls the breathing system.

Stepping motors. There are three stepping motors in the system: 1, 2 and 3. These motors are controlled by motor/drive indexers, A, B and C, respectively. Each motor runs in two opposite directions: positive and negative. For



Figure 1. Inhalation chamber and automated motion and breathing simulators.

example, in vertical motion of Dusty, positive motion is "moving up" and negative motion is "moving down." In horizontal rotation (turning head) moving head to the left is positive and to the right is negative. In vertical translation (nodding head), forward head motion is positive and backward movement is negative.³

Indexer programmer. The SSP-500 indexer programmer is a dedicated programmer which is designed to be used with a variety of drive/indexers including the 3180-PI used in this system. All functions, parameters, data, and commands for the microseries indexers can be easily entered, edited, upload-

ed and downloaded using this device. All information is clearly displayed on the two-line by 40-character liquid crystal display (LCD) panel. Seven function keys, Bi-Directional Cursor Locators, Numerical Keypad, Entry, and Mode keys provide easy and convenient data entry. All programming functions are menu-driven, and are presented in a clear, easy to follow sequence. The SSP-500 is designed to be either handheld or affixed on an exterior surface.⁴

Breather. The Breather is a box containing a vacuum/compressor pump and two three-way selenoid valves which alternate the flow of air from and to the vacuum/compressor pump.



Figure 2. Human-form dummy (Dusty) used in the system.

The opening and closing of these valves are controlled by the Drive/Indexer "A". The frequency of opening and closing of valves (same as respiration frequency) can be changed by programming the Drive/Indexer through the Indexer Programmer. A breath warmer/humidifier is also used on the exhalation line. For inhalation, the computer opens up the two valves in direction from the Dusty's mouth toward the vacuum pump; as a result, Dusty inhales the contaminated air from the chamber through the respirator being worn. At the end of inhalation cycle, the computer reverses the direction of airflow by switching the two solenoid valves in the opposite direction,

i.e., from the pump toward Dusty; as a result, room air is pushed through the warmer/humidifier and then into the Dusty's respirator cavity and out into the chamber through the respirator's exhalation valve. Volume and rate of breathing is adjustable through the indexer programmer. Therefore, increased rate of breathing can be set corresponding to the assumed rate of a worker's metabolic rate.

Portacount. Portacount is a highly versatile particle-counting instrument. It can accurately measure respirator fit factors, filter penetrations, and particle concentrations. Based on the

technology of continuous flow condensation nucleus counters, the portacount counts individual airborne particles from variety of sources. The instrument has two modes: Count Mode and Fit-test Mode. In the Count Mode, the portacount measures the concentration of airborne particles, whereas in the Fit-test Mode, the instrument measures the concentrations of particles inside and outside a respirator and calculates the respirator penetration or protection factor.⁸

METHODS

The system can be used to conduct variety of experiments on respirators. For example, to assess the risk of dust exposure associated with a specific respirator fit under a certain head and body motion and/or breathing rate, the following procedure may be followed:

1. The "test respirator" is fit-tested on Dusty's face by means of the Portacount, until satisfactory fit is achieved.
2. The Chamber is set on desired flowrate and dust (or other aerosols) generation rates so that the desired concentration is achieved within a reasonable time, i.e., approximately 5 minutes.
3. Dusty's motion and breathing systems (as programmed) are activated to run for a pre-determined length of time.
4. Dust concentrations outside and inside respirator is recorded continuously throughout the experiment. The extent of dust penetration into the respirator either through the face seal or any other route is detected at any time during the experiment and recorded on the strip chart. Any fluctuations in dust penetration for example, can also be matched with the Dusty's motion and breathing pattern. Such experiment is expected to provide answers to questions such as: (1) how long the respirator mask remains fit before a dust leak occurs? (2) which movement disturbs the respirator face seal, and to what extent? (3) what would be the effect of inhalation (negative pressure inside respirator mask), exhalation and/or breathing rate on dust penetration through the respirator? and (4) what would be the estimated risk of dust exposure involved under a set of conditions.

Operating the Robotic Dusty

Programming and operating the motion/breathing system, as stated earlier, is done through the Indexer/Programmer (Figure 3). The following is an example of the many programs used in this system. In this example, Dusty will carry out a consecutive combination of head and body motions: i.e., turning head, pumping tire, jogging in place, bending, turning head while bending, and turning while nodding. These motions will be accompanied by breathing at a rate of 15 respirations per minute and approximately 750 mL of air per respiration.

When using this program, the first mode appearing on the display of the Indexer/Programmer is the "OPERATING MODE" (Figure 3). The function key beneath each lower-case word will act on that word. For example, f7 key activates the indexers. Pressing this key will bring the display in Figure 4 which is "SELECT FUNCTION". Pressing f7 key (motion) again will move the system to the "MOTION" options

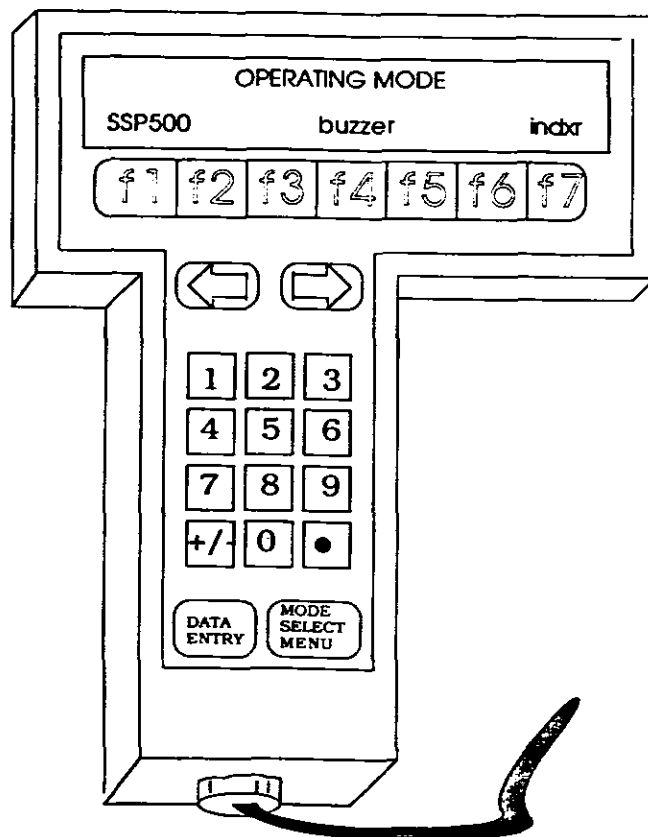

Figure 3.

(Figure 5). Here, the operator has several options; however, in this example, pressing f3 key (exec) would be the right choice. The next display (Figure 6) is "EXEC MOTION". Here again, several options are available; however, since the operator is asking Dusty to carry out all the motions, f4 key (all) should be pressed which will activate all indexers. This will take the operator to the last step of this program: "AUTO EXEC MOTION" (Figure 7). Out of several options available in this mode, pressing f1 key, CYCST (Cycle start) will start the system. Dusty will start the head and body motions, as stated earlier, in a consecutive fashion while breathing. Indexer/Programmer display during the operation would be "AUTO EXECUTING" (Figure 8). The system will continue to operate until the end of pre-set time on the program unless the operator wishes to stop the system at any time by pressing f1 key (stop). Pressing f4 (hold) may also be used should the system have to be stopped momentarily.

The robotic Dusty can also be run manually for each single motion by pressing f1 (man) in the "MOTION" mode (Figure 5). The next screen will show "ATT'N INDXR (01-99)" (Figure 9). The cursor on this screen will be flashing asking for the Drive/Indexer number of choice. Using the numeric key pad, one of the three indexers is activated by typing a zero and then the Indexer number: 01, 02 or 03. Once an Indexer is chosen, the "DATA ENTRY" key on the

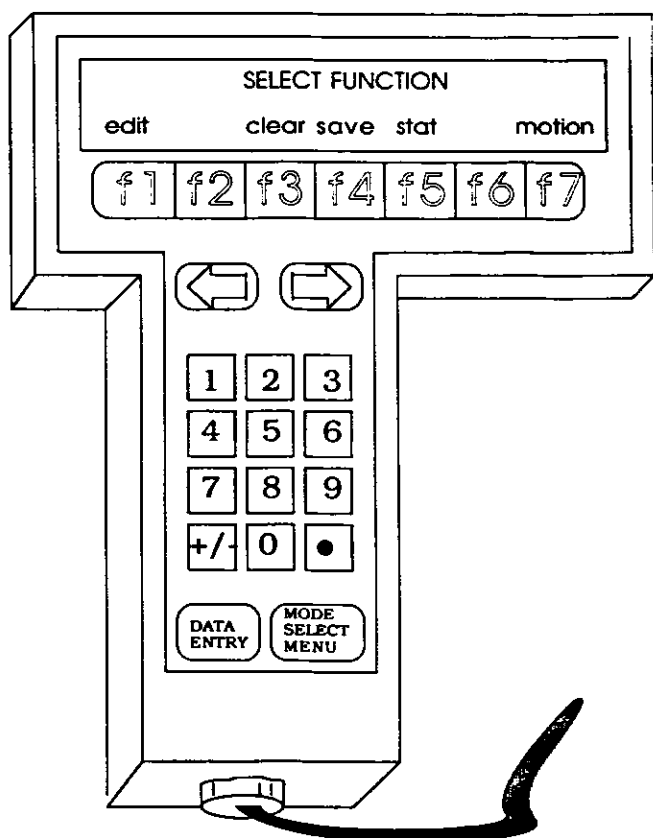

Figure 4.

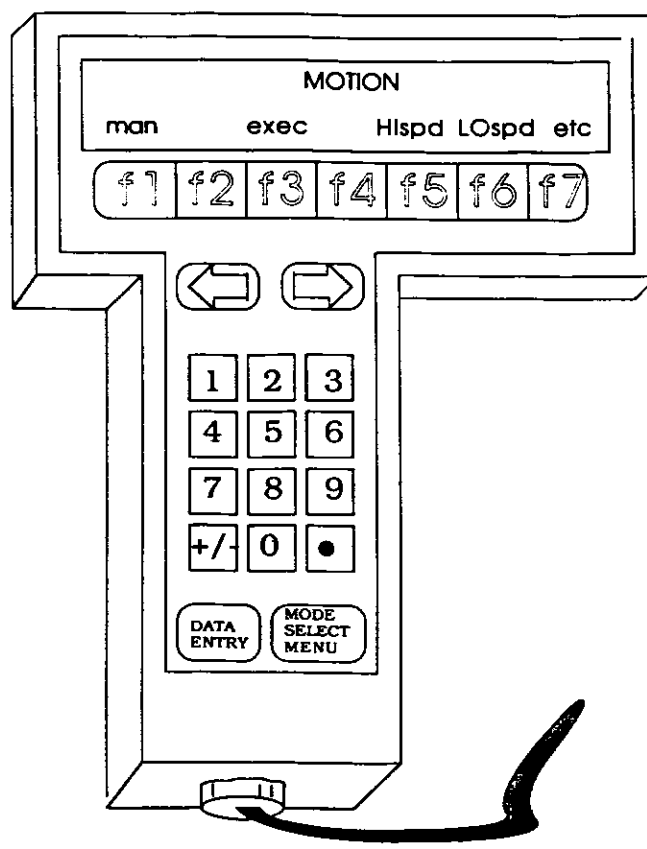

Figure 5.

Indexer/Programmer is pressed to activate the next screen of choice: "MANUAL MOTION" (Figure 10). The number in the upper left, here shown as "OX", will be the number of the indexer chosen. Several options are available on this screen. The one primarily used in manual control of the system is f2 (Jog). Pressing f2 will activate a continuous motion of the Dusty depending on the Indexer number chosen. The screen appearing during this operation will be "JOG MOTION".

In addition, the system can be programmed and executed to carry out varieties of desired motions or combination of motions (up to 999 choices). To execute the desired motion, f5 key (N) should be pressed during the AUTO EXEC MOTION (Figure 7). Using the numerical keypad, the desired motion number is then entered and followed by pressing "DATA ENTRY" key. The system is now ready to execute the desired motion indefinitely by pressing f1 key (Cycst).

If the system is stopped at any time during the operation, Dusty must be "returned" to its "electrical home" before a new cycle can be started. This is done by pressing f6 key (reh) in "MANUAL MOTION" mode (Figure 10).

REFERENCES

1. Breysse, N. et al.: Critical Review of International Standards for Respiratory Protective Equipment II. Gas and Vapor Removal Efficiency and Fit Testing. *Am. Ind. Hyg. Assoc. J.* 44:762-767 (1983).
2. da Roza, R. A. et al.: Reproducibility of Respirator Fit as Measured by Quantitative Fit Tests. *Am. Ind. Hyg. Assoc. J.* 44:788-794 (1983).
3. Instructions for SLO-SYN Micro Series Motion Controls Indexer/Programmer, Type SSP-500. Superior Electric, Bristol, CT 06010-7488 (1988).
4. Instructions for SLO-SNY Micro Series Motion Controls. Packaged Preset Indexers, Types 3180-P1. Superior Electric, Bristol, CT 06010-7488 (1988).
5. McGee, M.K., Oestenstand, R.K.: The Effect of the Growth of Facial Hair on Protection Factors for One Model of Closed Circuit, Pressure-Demand, Self-Contained Breathing Apparatus. *Am. Ind. Hyg. Assoc. J.* 44:480-484 (1983).
6. National Institute for Occupational Safety and Health: Evaluation of the NIOSH Certification Program. NIOSH Publication No. 80-113 (1979).
7. National Institute for Occupational Safety and Health: Human Variability and Respirator Sizing. NIOSH Publication No. 76-146 (1976).
8. PORTACOUNT, Operation and Service Manual. TSI Incorporated. St. Paul, MN 55164 (1987).
9. Ryan, C. et al: Critical Review of International Standards for Respiratory Protective Equipment. 1. Respiratory Protective Equipment for Particulate Laden Atmospheres. *Am. Ind. Hyg. Assoc. J.* 44:756-761 (1983).
10. Sketred, O.T., Loschiavo, J.G.: Effects of Facial Hair on Face Seal of Negative-Pressure Respirators. *Am. Ind. Hyg. Assoc. J.* 45:63-66 (1984).
11. Smith, T.J. et al: Inhalation Exposure of Cadmium Workers. Effects of Respirator Usage. *Am. Ind. Hyg. Assoc. J.* 45:63-66 (1984).
12. White, N. et al: Critical Review of International Standards for Respiratory Protective Equipment. III. Practical Performance Tests. *Am. Ind. Hyg. Assoc. J.* 44:768-773 (1983).
13. Wilke, K. et al: New Methods for Quantitative Respirator Fit Testing with Aerosols. *Am. Ind. Hyg. Assoc. J.* 42:121-125 (1981).

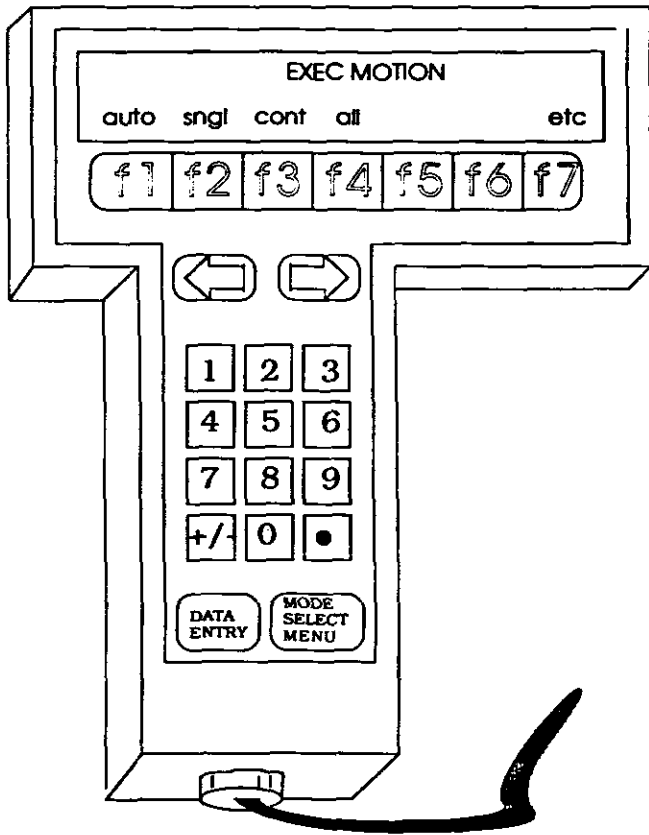

Figure 6.

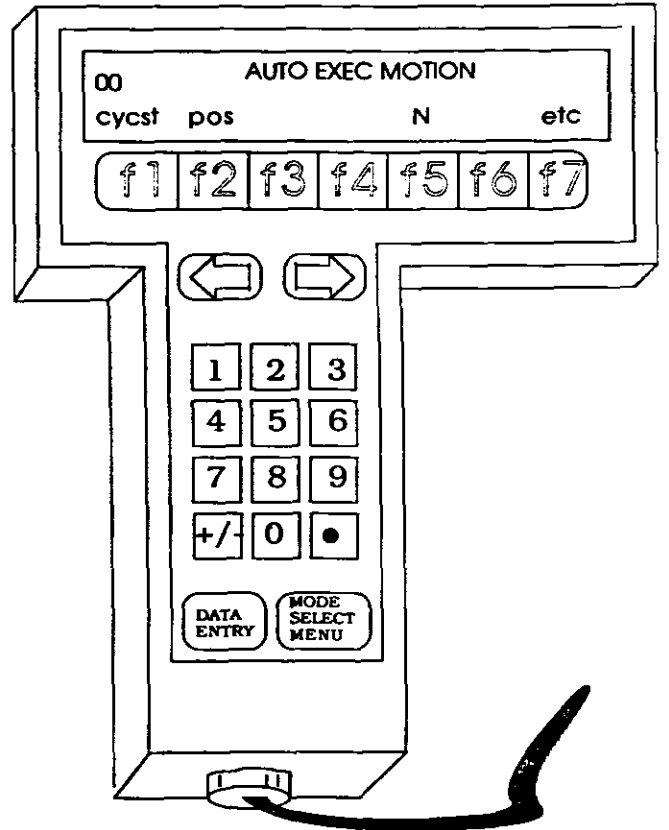

Figure 7.

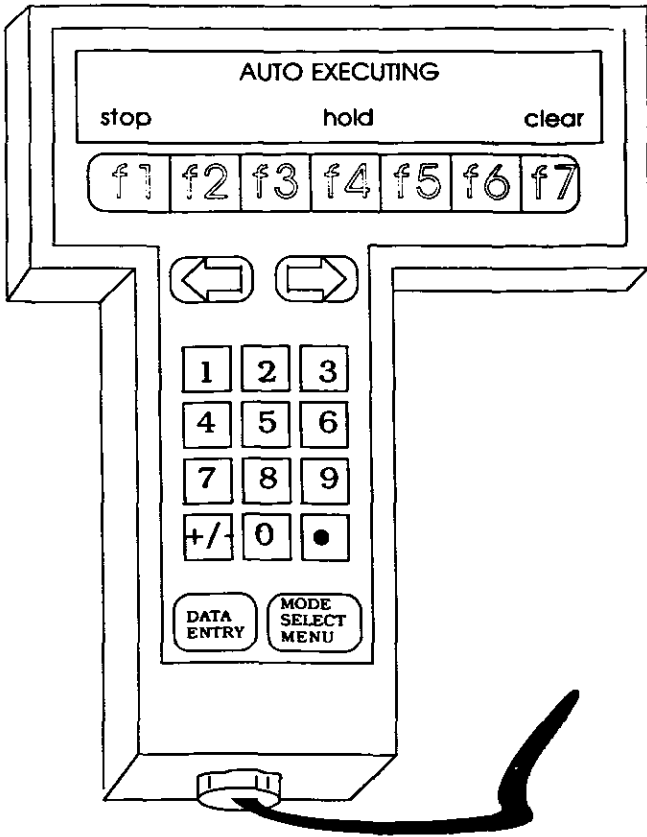

Figure 8.

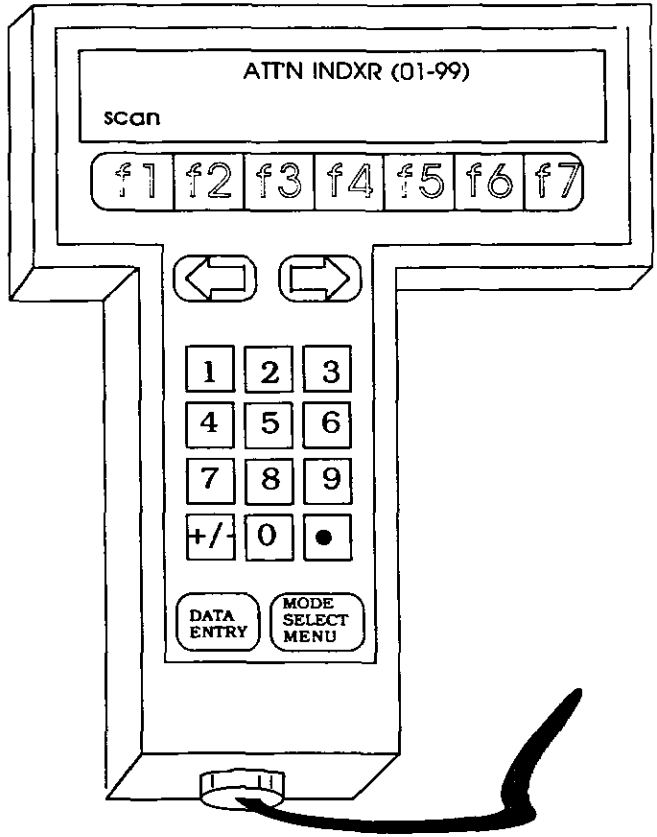

Figure 9.

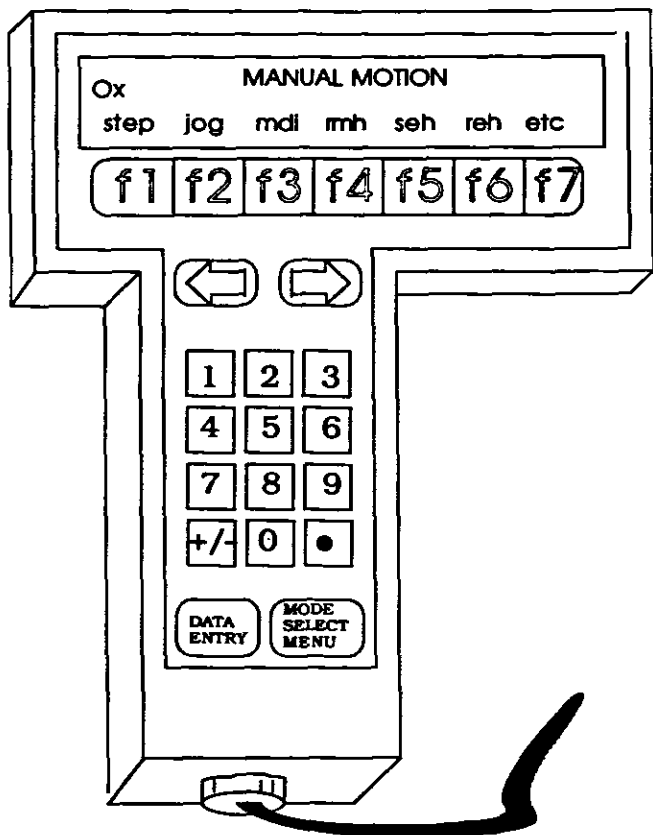

Figure 10.

RESPIRATORY PROTECTION EQUIPMENT PERFORMANCE STANDARDS IN DEVELOPING COUNTRIES

D.P. WILMES • P.E. Olsen • L. Hendricks

3M Occupational Health and Safety Products Division, Building 260-3-02, St. Paul, MN 55144, USA

Respirators are a very important factor in the line of defense against pneumoconioses. In less developed countries where resources are very limited to control the disease producing dusts and mists, respirators are probably the only viable method available for worker protection. Unfortunately, in these same countries, there are few standards or regulations governing the performance or use of respirators. Standards and regulations need to be developed to assure an adequate level of respirator performance and their proper use.

An effective certification procedure need not be complicated, especially for particulate respirators. Modern technology has made evaluation of the performance of respiratory protection much easier and more reliable than in the past. Simple procedures can be implemented to assure continued compliance with the standards.

For respirators offering protection against harmful dusts and mists the following aspects of respirator performance must be addressed:

1. Particulate penetration
2. Breathing resistance
3. Respirator fit

I would like to briefly discuss each of these aspects along with my recommendations as to how they can best be addressed in a certification program.

The most important aspect of respirator performance is its ability to exclude through its filters and components the harmful dust from the breathing air of the worker in a contaminated environment. In the past, filters or the entire respirator would be challenged with a laboratory generated test agent, such as silica dust. Air would be drawn through the respirator or filter at a specified rate. The amount of dust penetrating the filter or respirator would be collected on a second filter. After a specified period of time the second filter would again be weighed and the performance of the respirator reported as the total particulate penetrating the device, or the percent efficiency of the respirator or filter, if the challenge concentration was measured. This is the current NIOSH certification test.

The results of such tests are highly variable and are often poor predictors of actual respirator performance. For example two respirators that give equivalent results on the NIOSH silica dust test could give differing results if the instantaneous penetration were measured at any given time during the test. The old methods simply do not have the analytical sensitivity necessary to measure the actual performance of respirators.

In addition the equipment necessary to perform such a test is very expensive and difficult to operate and would consume a great deal of the testing agency's time.

Fortunately technology has simplified particulate respirator performance evaluation. Commercial equipment is now available to test particulate respirators in a manner applicable to respirator certification. This equipment uses a small worst case test aerosol so extrapolation to the aerosol found in the workplace is unnecessary. In European certification testing the aerosol is sodium chloride or paraffin oil generated by a controlled atomization.

TSI Inc. of St Paul, Minnesota, for instance, manufactures a unit that reliably and accurately measures the filtration performance of respirators. Their equipment can function with a variety of test aerosols. We have evaluated this test equipment with very encouraging results. The state of the art equipment was able to reproducibly measure filter performance with a coefficient of variation of less than 4% whereas the silica dust test has a coefficient of variation typically in the range of 60%.

The new equipment costs less than 20% of what a silica dust chamber would cost and is essentially a "turn key" test whereas the dust chamber would take at least 18 months to build and start up. This type of filter efficiency testing correlates very closely with tests that are performed in Europe and what is currently being proposed for use in the United States.

The second important aspect of respirator certification is the determination of acceptable breathing resistance of the respirator. This attribute of a respirator is important because it affects the user acceptance of the respirator. A respirator not worn when it should be will offer no protection. Determination of breathing resistance is a simple matter. In fact the state of the art filtration testing equipment automatically measures breathing resistance while determining filter efficiency.

The last aspect of respirator performance that requires addressing is facefit. In order for a respirator to provide adequate protection it must seal to the wearer in some manner that excludes the harmful dusts from penetrating the interface between the respirator and the wearer. This ability to seal is termed facefit. There are many accepted methods for determining how well a respirator fits. Because of limited time I will not discuss these methods but rather discuss approaches

of applying facefit testing to a respirator certification program.

Faces are highly variable. They come in many sizes and shapes and contain highly variable features. Generally, no one model of respirator will fit all faces. No one to date has been successful predicting the fit of a respirator on an individual using any scheme. Yet fit is a very important aspect in respiratory protection.

Generally two approaches have been used to address this problem. A method that is currently used in Europe and elsewhere requires that a respirator demonstrate some level of minimum fit on a substantial percentage of people on a test panel during the certification process. The fit of the respirator on the actual user is then largely ignored during actual use. The other method currently used in this country is to minimally address fit in the certification process but require through respirator use standards that an acceptable level of fit be determined on each respirator wearer. The first method acknowledges that some percentage of respirator users will not be protected because their respirator does not adequately fit whereas the second method places a burden on the employer to find a respirator that fits the individual if respiratory protection is required.

I believe that the second method is a much more protective standard. The availability of a greater variety of respirator sizes, shapes and models in this country than in Europe is in-

dicative that this method provides respirators with potentially better facefit.

I believe that a respirator certification scheme should require that a respirator manufacturer in the respirator user instructions specify a validated fit test must be performed to assure adequate facefit before the respirator can be relied upon for protection. This would provide assurances that the user has a respirator that adequately fits.

These three items are the most important aspects of a respirator certification program. However, a method of enforcement must also be implemented to assure continued compliance. The best method to accomplish this is for the agency to purchase product from the open market and test for compliance.

Before effective respiratory protection can be assured respirator use standards must be developed. If the proper respirators are not selected, if adequate fit cannot be ascertained and if the respirator wearers are not adequately trained in the proper use of the respirator protection will not be assured.

With the advancement of technology and existence of practical respirator use standards as models, regulations and standards should be adopted to assure adequate protection is available against pneumoconioses producing dusts and mists.

OPTIMIZATION OF FREELY SUSPENDED EXTERIOR HOODS IN INDUSTRIAL VENTILATION

NURTAN A. ESMEN, Ph.D. • Dietrich A. Weyel, Sc.D.

University of Pittsburgh, Graduate School of Public Health, Pittsburgh, Pennsylvania, USA

INTRODUCTION

In the design of an exterior hood, the value of the airflow rate through the hood can be found if specification of the "reach" of the hood is given. By the reach of the hood we mean a set of air speeds induced by the hood, to be achieved or exceeded at specified locations in front of the hood. If the velocity profile generated by the hood air flow is known, the problem is simply matching the velocity profile with the specifications to obtain the flow rate which will achieve the correct air speeds. There are a number of expressions which give velocity profiles with about equivalent accuracy.¹⁻⁴ Thus, any one of these expressions can be used to design a hood. Clearly, if the air speed specifications are given correctly, then the capture efficiency of the hood is expected to be optimal. It must be noted that the optimum for the capture efficiency can be made independent of cross currents, because the effect of cross currents can be included into the specification of the air speed. This seemingly direct and simple method of computation, which determines the minimum flow rate to accomplish the desired result, is flawed with respect to the mechanical efficiency of the hood. This flaw is due to the a priori selection of the hood geometry and orifice size without a quantitative investigation of the possibilities of achieving the same end result with a hood of different geometry and/or orifice size. Although the experience of the designer may be invoked as an influencing factor in the design, even for an experienced designer it is unlikely that the consequences of such alternatives have ever been a consideration.

In order to simplify the theoretical development, it will be assumed that a specific value of air speed on all points of a regular geometric shape defined on a plane located in front of a hood is given as the design criterion for the hood. It is important to note that the restriction of specification surface to a plane rather than a curved surface will not give a general solution. Therefore, it may be considered to be a limitation of the theoretical development. However, such a specification would be sufficiently common in the industrial applications and more importantly, the methodological approach can be presented without undue complexity of the mathematical formulation so that the results would be useful to a ventilation system designer.

THEORETICAL CONSIDERATIONS

In the investigation of the implications of hood orifice geometry and in the selection of proper size of the orifice, the development of the theory is facilitated if the specification

geometry is chosen in a way that the distances measured from the point on the hood is readily accomplished. This will suggest that the shape of the specification surface is symmetric with respect to both of the axes of the plane. An oblong or a circle would satisfy this criterion. Since a square has four extremal points, then the structuring of the optimization problem can be reduced to matching the air speed generated by the hood to the specified air speed at the extrema. This process would be sufficiently general, in the sense that the specification can be in terms of a component of a vector.

Suppose it is necessary to generate air speed of V_C at the surface of an oblong located on a plane parallel to the hood surface and centered on the x -axis with its sides parallel to the xz and yz planes. Furthermore, suppose that it is necessary to keep the hood face velocity equal to or below a specified value V_o . Let A and B be the maxima of the y and z coordinates respectively. For an oblong hood, with sides a fraction c of A and B placed with its center at the origin (Figure 1) minimization of the flow rate Q might be sought by the object function:

$$Q = L^2 f(a,b,h) V_C \quad (1)$$

Subject to:

$$V_C f(a,b,h) / 4abc^2 < V_o \quad (2)$$

where,

a = Dimensionless specification oblong side, A/L

b = Dimensionless specification oblong side, B/L

h = Dimensionless distance to the specification surface, H/L

For an oblong orifice, the function $f(a,b,h)$ may be shown to be represented by the non-dimensionalized velocity scaling function (1) multiplied by the hood orifice area:

$$f(a,b,c,h) = \frac{\pi(a+b)cr + 2\pi r^2 + 4abc(c+h(a+b))}{(a^2+b^2)^{1/2}} \quad (3)$$

with,

$$r^2 = h^2 + (1-c)^2 \quad (4)$$

Equations 1 through 4 can be extended directly to a circular orifice by taking $c.L$ to be the radius of the orifice. In such an extension, Equations 2 and 3 will have to be modified to conform to the description of the flow field in front of a circular orifice. The modified equation for a circular orifice hood

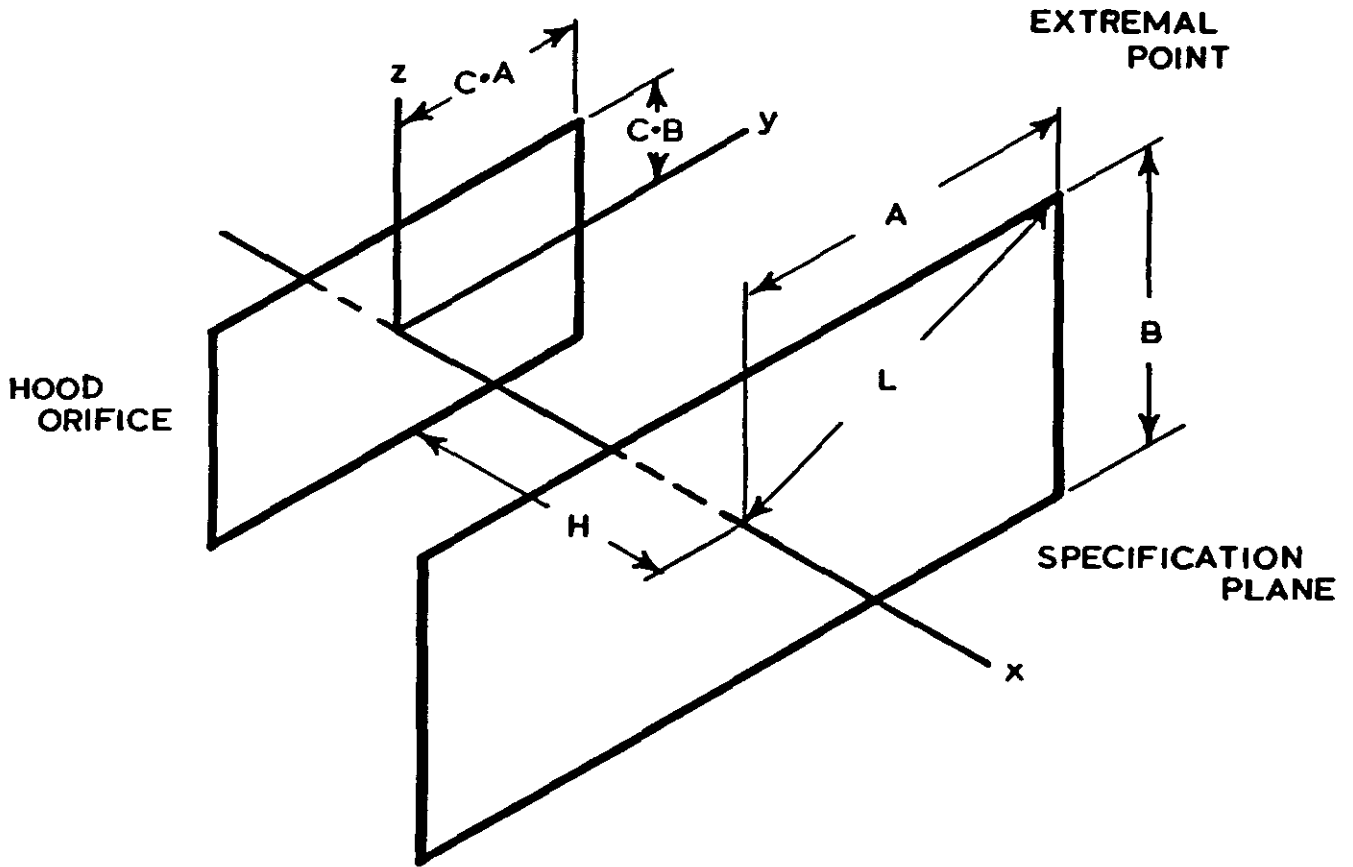

Figure 1. The parameters and the configuration used in the derivation of hood optimization.

may be shown to be 3:

$$f_C(a,b,c,h) = \pi^2(ct+r^2)/2 + \pi c(c^2 + Kh^2)^{1/2} \quad (5)$$

$$K = 4/(\pi^2 - 2\pi)$$

and,

$$V_C f(a,b,h)/\pi(a^2 + b^2)c^2 < V_o \quad (6)$$

The minimum sought may be found directly by differentiating either equation 3 or equation 6 with respect to *c* and finding the root of the resulting equation which is between zero and one. For an oblong orifice, the non linear equation to be solved is:

$$\pi(a+b) \frac{h^2 + 1 - 3c + 2c^2}{(h^2 + 1 - 2c + c^2)^{1/2}} + 4\pi(c-1) + 4abc \frac{2c^2 + h(a+b)}{(c^2 + h(a+b))^{1/2}} = 0 \quad (7)$$

and similarly for a circular orifice:

$$\frac{\pi}{2} \cdot \frac{h^2 + 1 - 3c + 2c^2}{(h^2 + 1 - 2c + c^2)^{1/2}} + \pi(c-1) + \frac{2c^2 + Kh}{(c^2 + Kh)^{1/2}} = 0 \quad (8)$$

If the specification surface, instead of oblong, is a circular one then calculation process may be modified by taking two different values for square or circular hoods. It may be shown

that for a square orifice hood the square hood $A = B$ and $L = A\sqrt{2}$ and for a circular orifice hood $L = A$. With these altered specifications equations 1 through 8 apply to optimization without further change. (Table I)

In general, the process of calculation is straight forward and with the use of a computer presents no significant problems. However, in certain cases no root may exist in the zero to one interval. This suggests that the global optimum design does not exist for that condition. This situation will arise when the dimensionless frontal distance *h* is sufficiently large. Consequently, the local optimum which is defined by the maximum face velocity specified in equation 2 or 6 and the corresponding orifice size may be used.

For infrequent design problems where the use of a computer is not warranted or for those who do not have ready access to a computer, there are a number of simplifications, albeit limited, that reduce the calculations to simple use of tables. To develop these simplifications, consider the specification surface to be bounded by a square, i.e. the sides are such that $A = B$. Then the optimization can be carried out utilizing the values shown in Table II. The simplest use of this table may be illustrated by an example. Suppose the specification surface is located 10 cm from the hood plane with $A = .025$ m.

If the air speed desired on this surface is 1 m/sec and the maximum face velocity allowed is 25 m/sec then the optimum hood size for a square hood is calculated as follows:

$L = A\sqrt{2} = 0.35355$ thus $h = H/L = 0.283$. Therefore, interpolating the proper values from Table II, $f(h) = 3.6191$ and $c = 0.784$; consequently, the optimum value of the side of the square hood is 19.6 cm and from equation 1 the volumetric flow rate is $0.45 \text{ m}^3/\text{sec}$. Similarly, for a circular hood, the optimum radius is 22.5 cm and the flow rate is

$0.49 \text{ m}^3/\text{sec}$. Thus for this simple illustration, a square orifice hood would be an optimum choice.

If the example above is recalculated using a circular specification, the optimum square hood would be the same, but the optimum circular hood would have $L = 0.25$, $h = 0.40$ which results in a hood radius of 13.0 cm and flow rate of $0.31 \text{ m}^3/\text{sec}$. In this case a circular hood would be superior.

It is important to note that the theoretical results developed

Table I
Optimization Parameters for Squares and Circles

Dimensionless Distance	Circle		Square	
	C	f(a, h)	C	f(a, h)
0.05	0.9351	2.2007	0.7734	3.1161
0.10	0.8926	2.4464	0.7344	3.2874
0.15	0.8594	2.7265	0.6953	3.4966
0.20	0.8291	3.0372	0.6641	3.7355
0.25	0.8018	3.3768	0.6211	3.9989
0.30	0.7754	3.7440	0.5859	4.2843
0.35	0.7598	4.1381	0.5508	4.5893
0.40	0.7266	4.5588	0.5156	4.9126
0.45	0.6992	5.0057	0.4805	5.2530
0.50	0.6758	5.4785	0.4414	5.6094
0.55	0.6562	5.9770	0.4062	5.9811
0.60	0.6328	6.5012	0.3672	6.3672
0.65	0.6104	7.0511	0.3203	6.7667
0.70	0.5869	7.6263	0.2634	7.1790
0.75	0.5635	8.2270	0.2266	7.6030
0.80	0.5400	8.8531	0.1719	8.0375
0.85	0.5166	9.5044	0.1094	8.4809
0.90	0.4932	10.1810	0.0312	8.9307
0.95	0.4688	10.8828	-----	-----
1.00	0.4434	11.6098	-----	-----
1.05	0.4209	12.3619	-----	-----
1.10	0.3965	13.1391	-----	-----
1.15	0.3721	13.9414	-----	-----
1.20	0.3467	14.7688	-----	-----
1.25	0.3203	15.6211	-----	-----
1.30	0.2949	16.4984	-----	-----
1.35	0.2695	17.4007	-----	-----
1.40	0.2441	18.3278	-----	-----
1.45	0.2148	19.2799	-----	-----
1.50	0.1914	20.2567	-----	-----

Circular orifices with maximum face velocity:

$$L^2 f_c(a, b, h) v_c - \pi(a^2 + b^2) c v_0 = 0$$

Oblong orifices with maximum face velocity:

$$L^2 f(a, b, h) v_c - 4 abc^2 v_0 = 0$$

Table II
Comparison of Traditional and Optimized Designs
(Unit Control Speed)

Design	B vert. cm	A Hor. cm	H cm	Diameter or Height cm	Width cm	Flow m ³ /sec
CASE I	15	15	15			
Traditional Square				30	-	0.354
Optimum Square				27	-	0.254
CASE II	20	30	25			
Traditional Oblong				40	60	1.12
Optimum Oblong				33	49	1.01
CASE III	10	20	30			
Traditional Oblong				20	40	0.902
Optimum Oblong				12	24	0.880
CASE IV	20	20	25			
Traditional Square				40	-	0.889
Optimum Square				25	-	0.830
CASE V	20	20	10			
Traditional Square				40	-	0.421
Optimum Square				19	-	0.358
Circle				15	-	0.359

above are not inherently limited to applications which involve specification surfaces assumed in the development. Obviously, if the specification surface is not nearly a square circular or square orifice hoods will be inherently inappropriate but must be replaced by oblong orifice hoods. Finding the roots of the derivative of the objective function may be carried out by hand but such a calculation would be cumbersome. Although the computerized solution is simple, when a computer is not available, the optimization of each dimension of the orifice may be carried out approximately, one at a time by treating each side as an independent imaginary square hood. Although the orifice dimensions determined in this manner may not predict the exact optimum design values, the resulting dimensions are expected to be near the optimum values. The flow rate for such an orifice cannot be calculated directly from Equations 1 to 4.

EXPERIMENTAL RESULTS

The direct experimental verification of the optimization procedure given above is at best cumbersome. Such an experiment would involve the construction of a very large number of hoods. However, an indirect experimental verification of the procedure may be accomplished by showing that a few representative hoods may be constructed and studied.

In the experimental study carried out to verify the theoretical calculations indirectly, three oblong hoods were constructed. These hoods were 5 cm by 5 cm square, 3 cm by 5 cm oblong and 4 cm by 8 cm oblong. With hood opening fixed, conditions under which these hoods will be optimum were calculated for different values of frontal distance and for each condition, the optimum flow rate was predicted. The air speed was measured at each, the theoretically determined specification point and the flow rate was adjusted until the air speed specification is fulfilled. This experimentally determined flow rate was then compared to the theoretical flow rate. All air flow and air speed measurements were carried out by hot wire anemometry. The hot film sensor in X configuration was calibrated in our laboratory and it is capable of measuring velocities with good accuracy and reproducibility. The hood airflow measurement was carried out by measuring the air speed by a traverse as close to the orifice plane as possible.

The comparison of the calculated optimum and the measured flow rates are given in Figure 2. The results suggest that the optimization procedure is satisfactory and perhaps slightly pessimistic in the indication of the flow rate required. On the average, about 10 percent less flow was required than it was calculated as necessary.

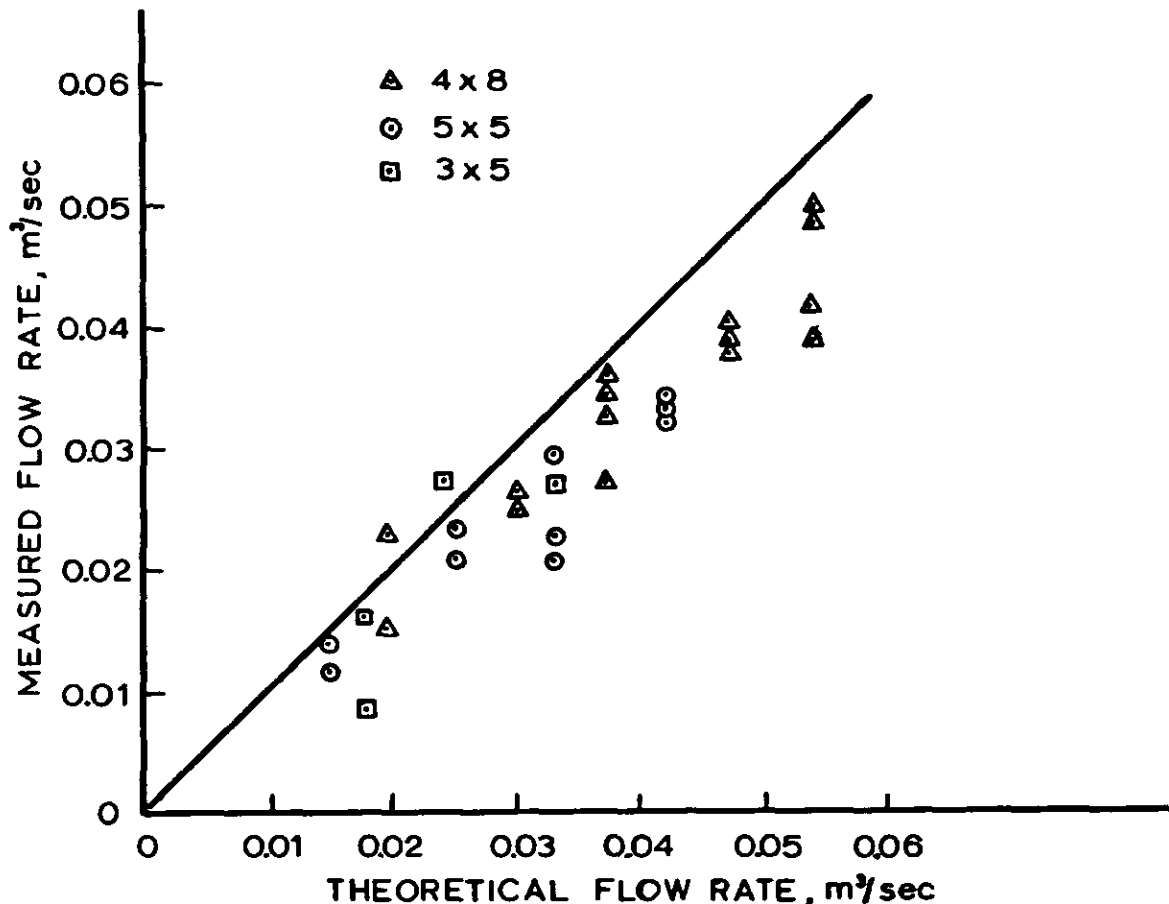

Figure 2. Comparison of theoretically and experimentally obtained flow rates for three hoods.

DESIGN APPLICATIONS AND DISCUSSION

The application of the results presented above to the design of freely suspended hoods with single square, circular or oblong orifices is a straight forward process but it must be recognized that the success of the hood design based on such calculations will ultimately depend upon the correct specification of the velocities to be generated at specific locations. The estimation of these velocities is beyond the scope of this paper and may be found in manuals dealing with currently accepted practice. If the specification surface is judged to be a curved surface rather than a plane or if the vector components of the velocity at specified points are sought, new objective functions following the theoretical development above can be found. Alternately, the hood size may be selected at an external point by considering that point to be one of the vertices of an oblong specification surface and the proper flow rate through the system can be calculated by point matching between the generated flow field and the required flow field.

In order to show the efficacy of the optimization procedure developed here, five hypothetical cases were compared to the traditional design procedure. The results of this comparison are shown in Table II. For the cases shown in Table II, the efficiency gain through optimization is about 13 percent with a range from 2 to 30 percent. These cases were not constructed with a forethought to show the effectiveness of the optimiza-

tion procedure, but rather they were arbitrarily selected. Since the optimization process is based on the velocity profile in front of the hood, and the traditional design procedure which is based on the adjustment of the centerline velocity of the hood, then the hood designed by the optimization procedure ensures that the air speeds specified on the specification plane are satisfied. On the other hand such a statement would not necessarily be correct for the design based on centerline velocity. Consequently, the hoods designed through the process described above would always have a superior total efficiency as compared to the traditionally designed hoods.

REFERENCES

1. Esmen, N.A., Weyel, D.A.: *Aerodynamics of multiple orifice hoods*. Ventilation 1985, Elsevier H.D. Goodfellow (edit.) New York, p. 735-743, (1986).
2. Esmen, N.A., Weyel, D.A., McGuigan, F.P.: Aerodynamic properties of Exhaust Hoods. *Amer. Ind. Hyg. Assoc. J.* 47:448-454, (1986).
3. Esmen, N.A., Weyel, D.A., Pirris, A., Ilori, A.G.: Aerodynamics of Arbitrarily shaped orifice exterior hoods II: Experimental study. *Ann. Occup. Hyg.*, (in press).
4. Flynn, M.R., Ellenbecker, M.J.: The potential flow solution for airflow into a flanged circular hood. *Amer. Ind. Hyg. Assoc. J.* 46:380-389, (1985).

This research was supported by The National Institute for Occupational Safety and Health under a research grant number of 1-RO-1-OHO2132-03.

SIGNIFICANT REDUCTION OF QUARTZ DUST CONCENTRATIONS IN THE NATURE STONE INDUSTRY DUE TO THE INTRODUCTION OF VENTILATION SYSTEMS

VERNINGERUNG VON SCHADSTOFFKONZENTRATION DURCH LÜFTUNGSTECHNISCHE MAßNAHMEN IN DER NATURSTEININDUSTRIE

ROBERT FEIGHOFEN, Dipl.-Ing.

Steinbruchs-Berufsgenossenschaft, Hannover, F.R. Germany

EINLEITUNG

Die wirksame Erfassung luftfremder Stoffe und ihre gefahrlose Niederschlagung stellt eine der zentralen Arbeitsschutzmaßnahmen dar. Beim Umgang mit diesen Stoffen können diese in Form von Stäuben, Gasen oder Dämpfen in den Arbeitsbereich der Beschäftigten gelangen.

Im Bereich der Steinbruchs-Berufsgenossenschaft haben wir es vor allem mit silikogenen Stäuben zu tun. In der Natursteinindustrie, hier insbesondere in der Granitindustrie, war es dringend notwendig, Maßnahmen zur Emissionsminderung zu ergreifen. Eine der Maßnahmen zur Emissionsminderung war die Erfassung luftfremder Stoffe an der Emissionsquelle. Die hierzu notwendigen Einrichtungen waren in ihrer Wirkung zu optimieren. Für die Berechnung lagen selten geschlossene Lösungen vor, vielmehr war man auf Praxiserfahrung angewiesen.

Möglichkeiten der Verringerung von Schadstoffkonzentration durch lüftungstechnische Maßnahmen sollen an Beispielen der Staubbekämpfung in der Granitindustrie aufgezeigt werden.

TECHNISCHE SCHÜTZMAßNAHMEN

Allgemeines

Die Absaugeinrichtung soll den bei den Bearbeitungsvorgängen entstehenden Feinstaub an der Ausbreitung über die Entstehungsstelle hinaus hindern.

Der nicht flugfähige Grobstaub sedimentiert schnell und lagert sich ab. Der Feinstaub dagegen breitet sich mit jeder Luftströmung aus. Er gelangt in die Atemzone und sein Anteil kleiner als $5 \mu\text{m}$ in die Atemorgane. Die Erfassung des Staubes an der Entstehungsstelle kann z. B. bei der Verwendung von Druckluftwerkzeugen durch eine das Werkzeug weitgehend umschließende Kapselung oder durch punktförmige Absaugung erfolgen.

Bei überwiegender Handarbeit oder auch bei Verwendung von Schleif- oder Trennwerkzeugen in geschlossenen Hallen werden als Erfassungselemente vielfach Saugtrichter in den

unterschiedlichsten Formen eingesetzt. Bei maschineller Bearbeitung werden Kapselung, Absaugdüsen oder auch die Absaugung durch eine Bohrung im Werkzeug angewandt.

Stauberfassung bei der Bearbeitung mit Werkzeugen

1. Kapselung

In der Granit-Werksteinindustrie befinden sich eine große Anzahl der Arbeitsplätze im Freien oder in halboffenen Steinhauerhütten. In diesen Hütten werden überwiegend Rand-, Leisten-, Grenz- und Mauersteine hergestellt. Für die Bearbeitung werden Druckluftwerkzeuge verwendet.

Eine Erfassung des bei der Bearbeitung entstehenden Staubes kann an diesen Arbeitsplätzen nur durch eine möglichst weitgehend das Werkzeug umschließende Kapselung erfolgen.

In den früheren Jahren hatte man sich bei der Staubbekämpfung an diesen Arbeitsplätzen überwiegend auf den Arbeitsvorgang "Stocken" konzentriert, da hierbei die größte Staubentwicklung auftrat.

Es wurde als Stauberfassungs-Einrichtung für diesen Arbeitsvorgang zunächst der Schardinger Topf entwickelt. Der "Topf" wird über den Meißelhals gesteckt und ist an diesem festgelegt. Der "Topf" selbst liegt auf der zu bearbeitenden Fläche und wird mit dem Keillochhammer zusammen über die Fläche geführt. Bedingt durch die Bewegung über die raue Oberfläche des Werkstückes wird er stark abgenutzt. Auch ergeben sich gelegentlich Schwierigkeiten beim Bearbeiten an den Kanten der Werkstücke.

Beim sogenannten Hauzenberger Topf wurde ein neuer Weg beschritten. Der Absaugkopf ist an einem Rillenkörper, welches die Haltemutter des Hammers ersetzt, drehbar angebracht. Mit einem Handgriff kann der Absaugkopf auf die jeweilige Länge des Werkzeuges eingestellt werden. Der untere Rand des Topfes soll sich stets im geringstmöglichen Abstand über dem Werkstück befinden. Bedingt durch das zusätzliche Gewicht müssen die mit dem Hauzenberger Topf

ausgestatteten Hammer von einer besonderen Führung gehalten werden. Ein freihändiges Arbeiten ist nicht möglich.

Eine Weiterentwicklung des Hauzenberger Topfes ist eine Gummihäube mit seitlichem Saugstutzen. Diese Gummihäube wird fest mit dem Stockhammer verbunden und beim "Stocken" mit Hartmetallwerkzeugen verwendet. Der Hammer kann auch von Hand geführt werden.

Schwierigkeiten bei der Benutzung dieser Absaugeinrichtungen treten beim Bossieren, Spitzen und Keillochmachen, d.h. bei Arbeiten mit dem Spitzeisen auf.

Bei der groben Bearbeitung von Flächen ist es notwendig, den Hammer in mehrere Richtungen zu bewegen. Für diese Arbeitsvorgänge, die außerdem noch mit Spitzeisen unterschiedlicher Länge durchgeführt werden, wären die starren Absaugtopfe nicht geeignet. Ein Heranführen der Absaugdüse an die Bearbeitungsstelle war nicht möglich.

In den letzten 10 Jahren ist es gelungen, auch Einrichtungen zum Erfassen des Staubes für diese Arbeitsvorgänge zu schaffen und zu verbessern. Die Stauberfassungseinrichtungen bestehen aus einer Gummikappe mit seitlichem Saugstutzen, die über die Haltemutter des Keillochhammers gezogen wird. In eine in dieser Grundhaube angebrachte Nut werden die mit einem Falz versehenen Absaugdüsen von unterschiedlicher Länge und Form für die verschiedenen Arbeitsvorgänge eingesteckt.

Man ging auch hier wieder davon aus, den Staub möglichst nahe an der Entstehungsstelle zu erfassen. Je näher die Erfassung des Staubes an der Entstehungsstelle erfolgt, desto geringer kann die erforderliche Absaugluftmenge gehalten werden. Das bedeutet wiederum, daß die Absaugvorrichtung am Hammer klein und gering im Gewicht und der erforderliche Absaugschlauch auch klein im Durchmesser bleiben können.

Im unmittelbaren Zusammenhang mit einer Absaugluftmenge steht auch die Größe der Anlage und damit deren Kosten.

2. Punktförmige Absaugung

Für verschiedene Arbeiten mit schlagenden Druckluftwerkzeugen, überwiegend in geschlossenen Hallen, wird die Punktabsaugung verwendet. Die Absaugung erfolgt mit einem flexiblen Saugrohr oder Schlauch. Der Schlauch oder das Saugrohr sind am Drucklufthammer befestigt. Das Ende des Schlauches bzw. des Rohres ist so nahe wie möglich an die Entstehungsstelle des Staubes nachzuführen, damit eine ausreichende Erfassung des Staubes erfolgt. Bei der Punktabsaugung wird ebenfalls mit einer geringen Absaugluftmenge gearbeitet.

3. Absaugung mit dem Saugtrichter

Es ist allgemein bekannt, daß auch bei der Steinbearbeitung mit Handwerkzeugen eine erhebliche Staubentwicklung auftritt.

In diesen Fällen ist eine Erfassung des Staubes nur durch Saugtrichter möglich. Diese Art der Absaugung erfordert jedoch wesentlich höhere Absaugluftmengen als bei

Kapselung oder Punktabsaugung. Bei Verwendung von Druckluftwerkzeugen oder elektrisch angetriebenen Werkzeugen ist besonders darauf zu achten, daß die Flugrichtung des Staubes zur Häube hin zeigt.

4. Absaugung mit Absaugtischen

In Jura-Marmorbetrieben werden bei der Steinbearbeitung auch Absaugtische eingesetzt.

Bei trockener Bearbeitung von Kanten mit Elektrowerkzeugen wird hier der Staub über einen unter dem Tisch eingebauten Entstauber abgesaugt. Bei Arbeiten mit dem Absaugtisch ist darauf zu achten, daß die Halterung für das zu bearbeitende Werkstück entsprechend nachgestellt wird. Die zu bearbeitende Kante muß möglichst nahe der Ansaugöffnung liegen. Nur so kann eine einwandfreie Erfassung des Staubes erfolgen.

Hilfseinrichtungen

Außer bei den Stockarbeiten mit Gestängeführung des Druckluftwerkzeuges bereitet das Nachführen der Erfassungseinrichtungen und der Schläuche stets Schwierigkeiten.

Dieses Problem ist jedoch weitgehend gelöst. Bei Druckluftwerkzeugen, bei denen die Erfassungseinrichtungen unmittelbar am Werkzeug angebracht sind, werden Druckluft- und Saugschlauch gemeinsam über einen Gelenkarm zum Werkzeug geführt. Der Gelenkarm mit aufgesetztem Pendelarm hat eine Länge von ca. 3 m, so daß ein ausreichend großer Schwenkbereich vorhanden ist. Eine Zugentlastung sorgt für den Gewichtsausgleich.

Bei Anlagen mit Saugtrichter wird dieser an eine nach allen Seiten bewegliche und in der Höhe verstellbare Rohrleitung angebaut oder der Trichter befindet sich an einem flexiblen Schlauch bzw. an flexibel über Schlauchstücke verbundenen Rohren, die an Gelenkarmen verschiedenster Bauart befestigt sind. Die Leichtgängigkeit der Gelenkarme muß stets gewährleistet sein, da die Saugrüssel sonst nicht ständig nachgeführt werden. Eine ausreichende Staubabsaugung ist dann nicht mehr gegeben.

Sind die Hilfseinrichtungen umständlich zu handhaben oder schwergängig, so wird die gesamte Staubabsaugung in der Regel von den Arbeitern abgelehnt.

Staubabsaugung bei Bearbeitung mit Maschinen

1. Pflasterstein-Spaltmaschine

Der beim Spalten entstehende Staub wird durch seitlich neben dem Obermesser und unter dem Tisch angeordnete Düsen abgesaugt.

2. Randstein-Stockmaschine

Mit der Randstein-Stockmaschine werden die von Hand grob vorbereiteten Steine durch im Innern der Einkapselung angeordnete Stockhammer bearbeitet.

Der dabei anfallende Grobstaub wird mit einer Förderschnecke, der Feinstaub durch Absaugung aus dem

Gehäuse entfernt.

3. Trog-Fräsmaschine

Bei der Trog-Fräsmaschine erfolgt die Absaugung des Staubes durch das einem Holzbohrer ähnlich gestaltete Fräs Werkzeug.

STAUBABSCHIEDER

Als Staubabscheider werden meistens Gewebefilter, neuerdings auch Sinterlamellenfilter verwendet. Als Antriebsenergie benutzt man überwiegend Strom oder Druckluft.

Um den Energieverbrauch für die Entstaubung bei der Steinbearbeitung mit Druckluftwerkzeugen und Stauberfassung am Werkzeug möglichst niedrig zu halten, werden in verschiedenen Betrieben sogenannte Einzelentstauber verwendet. Jeder Arbeitsplatz hat für sich ein Absauggerät. Es handelt sich hier um Injektor-Geräte.

Ein Steuerventil sorgt dafür, daß das Entstaubungsgerät nur

läuft, wenn mit dem Drucklufthammer gearbeitet wird. Der Druckluftverbrauch wird bei dieser Arbeitsweise erheblich gesenkt.

SCHLUßBETRACHTUNG

Für alle bei der trockenen Bearbeitung von Werkstein vorkommenden Arbeiten gibt es entsprechende Staubabsaugungen.

Voraussetzung für eine einwandfreie Entstaubung der Arbeitsplätze ist jedoch die bestimmungsgemäße Verwendung und sorgfältige Wartung der Erfassungseinrichtungen und Anlagen.

Bei der Steinbearbeitung mit handgeführten Geräten oder Handwerkzeugen bedeutet die Verwendung der Absaugeinrichtungen stets eine leichte Behinderung. Nach einer Einarbeitungszeit werden die Einrichtungen von den Beschäftigten im allgemeinen angenommen, da die meisten von ihnen erkannt haben, daß die Anlagen der Erhaltung ihrer Gesundheit dienen.

EXPLORATIONS TO SOME PROBLEMS IN ESTABLISHING DUST ALLOWABLE CONCENTRATIONS

LIU ZHANYUAN • Zhang Weichang • Fang Yuxiang • Xiao Xingyuan

Liaoning Institute of Labour Hygiene, Shenyang, China, PRC

Certain difficulty exists, either theoretically or methodologically, in studies on dust allowable concentration.

Before the 1950s, allowable concentration only existed for silicon dioxide and, later, that for asbestos was added. In the past decade of years, the establishing of dust allowable concentration has developed rapidly, but is still far from meeting the practical need.

To improve method for study and to speed up its development, therefore, has become an urgent problem to be solved at present. The present article is exploring some problems in establishing dust allowable concentration as follows:

TREND IN DEVELOPMENT OF DUST ALLOWABLE CONCENTRATION

Along with increase in number of newly-established dust allowable concentration, classification naturally appears. The ACGIH of the United States divides mineral dust TLV into four major categories.² In the Soviet Union, in addition to 53 kinds of mixed dust allowable concentrations established separately,¹ the maximum dust allowable concentrations are classified into silicate, carbon, metal and organic matter except that of silicon dioxide. The dust allowable concentration published by Japanese Industrial Society falls into three major categories: silicon dioxide, "various dusts" and asbestos,³ while in China, dust allowable concentration may be divided into six major categories: silicon dioxide, silicate, carbon and coal, metal, organic dust, and others.⁴

A tendency toward grading has turned up. As for free silicon dioxide dust, in some countries, it is classified into two grades, while in some other countries it is classified into four grades and in some countries, it is calculated by equation (see Table I). In Japan, the "various dusts" with free silicon dioxide content less than 10% are divided into three grades.³ In Soviet Union, no apparent grading is done, but in effect, the 65 kinds of other various dusts with free silicon dioxide less than 20% are classified into six grades as 1, 2, 4, 6, 8, and 10.² In China, the various dusts except silicon dioxide are divided into five grades as 3, 4, 5, 6, and 10.⁴

GENERAL STRUCTURAL CONSTRUCTION OF DUST ALLOWABLE CONCENTRATION

Having analyzed historical development tendency, we propose to establish structure with classification and grading for dust allowable concentration.

1. Seven categories are classified according to dust characteristics:
 - a) silicon dioxide dust
 - b) silicate dust
 - c) metal dust
 - d) coal dust and various carbon dust
 - e) organic dust
 - f) various mixed dust
 - g) other dust.

One of the purposes of classification is to work as reference for identical dust allowable concentration developed.

2. Four categories are classified according to extent of harm done by dust (see Table II).

One of the purposes of classification is to simplify the method, to speed up establishing concentration, as well as to benefit monitoring. In recent years, some countries have adopted the method of calculating the SiO₂ dust allowable concentration with formula, which gives an impression of accurate quantity, but in effect, by present available method and means it is difficult to reflect accurately the changing factors of pneumoconioses' occurrence due to the complex nature of the disease's developing course and the unstableness of workers exposed to dust in production. This method gives rise to a series of problems to monitoring. According to the study results of pneumoconioses in the province in the past twenty years, we think that to divide dusts into four major grades according to occupational harm they have done may generally distinguish the extent of harm done by various dusts.

ON THE STUDY METHOD OF DUST ALLOWABLE CONCENTRATION

Data on epidemiology disease is doubtless the key basis for establishing dust allowable concentrations as well as a must data, but pneumoconioses is a chronicle developing process, especially the new industrial dust for which its allowable concentration cannot be established after long periods of time waiting for the data of epidemiology disease. Then, is it possible to take it as a basis for establishing dust allowable concentrations with animal experiments?

We think it is. As is known, pneumoconioses is a disease that can be studied with certain pathological models established on animal experiments. Analysis of animal experiments on about twenty kinds of dusts, conducted in contrast with data

Table I
Grading of Free Silicon Dioxide Dust Allowable Concentration in Various Countries (mg/m³)

Country	Other dusts	Content of free silicon dioxide (%)								
		-1	-2	-10	-30	-40	-50	-70	-80	>80
China	10						2			1
Soviet Union	10		4			2			1	
Japan	1.5	3.0	6.0			2.9		12		
						R= $\frac{\quad}{0.22Q+1}$		T= $\frac{\quad}{0.22Q+1}$		
U.S.A.	10					0.05~0.1				

Note, R = The inhalant dust

T = Total dusts

Q = Content of free SiO₂ in dust (%)

Table II
Grading of Dust Allowable Concentration

Extent of harm	Grading	Max. allowable concentration (mg/m ³)	Dust
Very serious	I	1	Pure quartz dust with free SiO ₂ over 80%
Serious	II	2	Various dusts with free SiO ₂ between 10~80%. Asbestos dust.
Moderate	III	5	Various dusts with free SiO ₂ between 5~10%; partial silicate dust (as talcum dust); partial metal dust (as metallic aluminium dust).
Slight	IV	10	Various dusts with free SiO ₂ less than 5%; partial silicate dust (as pearlite and dolomite); carbon and coal dust; partial metal dust (as tin); and organic dust, etc.

Table III
Cases of Grading of Harm Done by Dust
(According to Length of Time for Appearance of Fibering)

Grading	Length of time of appearance of fibering of pulmonary tissue when animal is contaminated (month)	Name of dust experimented
I	3	Pure quartz dust (with 85~90% of free SiO ₂)
II	6	Ceramic mixed dust, caly (A) dust (15~35% of free SiO ₂)
III	12	Mixed clay (B) dust (5.9% of free SiO ₂)
IV	18	Pearlite dust, clay (C) dust (0.5~3.6% of free SiO ₂)

Fibering standard, appearance of gelatinizing fiber on the basis of hyperplasia of netted fiber

of epidemiology, may basically reflect the extent of occupational harm done by various dusts with animal experiments. The pneumoconioses with high occurrence, short work age, rapid development and high mortality (such as that caused by quartz dust) appears rapid fibering of pulmonary tissue and serious extent of pathological change in animal experiments, while in reverse, the pneumoconioses with low occurrence, long work age of occurrence, slow development and low mortality (such as pneumoconioses caused by clay dust) appeared slow in fibering of pulmonary tissue and slighter extent of pathological exchange in animal experiments. With the time for rat lung to show fibering as the basis of grading, results of grading at various dusts are shown in Table III. These results provide a possibility to use animal experimental data for establishing dust hygienic standard. The united animal experiment method can be determined by the National Hygiene Standard Commission. The standard dust for contrast may be supplied by the National Labour Hygiene Study Center and it is for all the local labour hygiene study centers to direct the experimental method. All labour hygiene and scientific research departments can engage in study and development of dust allowable concentration. Checked and approved by the Hygiene Standard Commission, the study results can be published and put into force as a provisional standard. In the second stage, the standard can be revised according to data

of epidemiologic investigation. Thus it is possible to speed up the establishment of dust allowable concentration.

The pathological grading of animal experiments can be based on the speed of the appearance of fibering for the time being. Obviously, there are many problems to be further explored such as, the biological effect of dust cannot be attributed to whether there is fibering effect. Therefore, it is very important to set up a systematic study method for pulmonary toxicity experiments. It is, however, advisable, from technical development strategy, to select a practical and feasible method.

REFERENCES

1. Санитарные правила проектирования промышленных предприятий (ГОСТ 12.1005-76), 1976.
2. ACGIH, Threshold limit values for chemical substances in workroom air adopted by ACGIH for, 1981.
3. Japanese Industrial Hygiene Society, Allowable Concentration (1) Report (1980), *Industrial Medical Science* 22(5), 421, 1980.
4. Hygiene Standard for Industrial Enterprise Design, Beijing, 1979.
5. Shong Tengyuan: Some Problems on Allowable Concentration. *Labour Science* 56(6), 335, 1980.
6. WHO: Methods used in the USSR for establishing biologically safe level of toxic substances, Geneva, 1975.

CRITERIA FOR DETERMINING WORK RELATED HEAVY ASBESTOS EXPOSURE

K.C. WAN, MBBS, DIH, M.Sc. • N.R. Street, MBBS

Occupational Medicine Branch, Department of Occupational Health, Safety and Welfare, Western Australia (DOSHWA) and Workers' Compensation and Rehabilitation Commission (WCRC), Western Australia

INTRODUCTION

The objective of this paper is to derive from case records, guidelines for which occupations and operations constitute heavy asbestos exposure.

Schedule 3 of the Workers' Compensation and Assistance Act, Western Australia (1981) contains a list of specified industrial diseases for which Workers' Compensation may be obtained. One of the diseases listed in Schedule 3 is lung cancer associated with "any process entailing heavy exposure to asbestos dust." The term "heavy exposure" is not defined.

METHOD

All claimants for Workers' Compensation for pneumoconioses attend at the Perth Chest Clinic. Perth Chest Clinic records of Workers' Compensation claimants diagnosed by the Pneumoconiosis Medical Panel as silico-asbestosis or asbestosis were examined for Wittenoom Australian Blue Asbestos (ABA) workers for the period 1 July 1987 to 31 December 1987 (15 cases) and the DOSHWA Asbestosis Register was examined for "non ABA" workers for the period 1 January 1979 to 31 December 1987 (36 cases). Mining and milling of blue asbestos was located in the town of Wittenoom, which is in the North-West of Western Australia, from 1943-1966. "Non-ABA" cases were further divided into Waterside Workers (9 cases), Asbestos-Cement Products Manufacturing Workers (9 cases), Railway Workers (5 cases) and "Other" (13 cases).

All the cases on the Perth Chest Clinic records who successfully claimed Workers' Compensation for mesothelioma from 1 January 1979 until 31 December 1987 were examined (101 cases). All the cases on the Perth Chest Clinic records who successfully claimed Workers' Compensation for lung cancer from 1985 (when lung cancer became a specified industrial disease under the Act) until 31 December 1987 were examined (12 cases). For each of the above three disease categories, the resulting data were classified according to occupation and duration of exposure.

RESULTS

Asbestosis and Silico-asbestosis

From 1 January 1979 until 31 December 1987 (9 years) the DOSHWA Asbestosis Register contains the names of 154 peo-

ple. Of these, 118 (77%) had worked for ABA in Wittenoom.

As it is generally accepted that having worked mining or milling crocidolite asbestos at ABA for even relatively short periods constitutes a history of heavy exposure, it was decided to look at only a small number of ABA workers, namely those who had successfully claimed Workers' Compensation for asbestosis or silico-asbestosis between 1 July 1987 and 31 December 1987 (15 cases). Of these 15 cases, occupational histories were available for 14, and, of these, only 6 (40%) had worked exclusively in one type of operation, the remaining 8 having worked in multiple operations. These 14 workers had been engaged in a total of 21 different operations at ABA. The mean duration of working at ABA was 43 months (range 3-96 months).

Information was obtained from the Perth Chest Clinic records for the 36 "non-ABA" workers registered on the DOSHWA Asbestosis Register from 1979 until 1987 inclusive.

Of the 9 Waterside Workers registered, 78% were involved exclusively in the one operation of loading/unloading bags of asbestos. The mean duration of employment for waterside workers was 235 months (range 84-384 months). Of the 9 Asbestos-Cement Products Manufacturing Workers, 4 (44%) of these had worked in a single operation. The nine workers had worked in a total of 19 different operations. The mean duration of employment for this group of workers was 231 months (range 28-416 months). Of the 5 Railway Workers, 4 (80%) had worked in only one type of operation. The mean duration of working for the Railways was 223 months (range 72-504 months). The number of cases of asbestosis and silico-asbestosis amongst the different occupational groups described above, together with the mean durations of employment, standard deviations and ranges are summarized in Table I.

Mesothelioma

All the cases of mesothelioma in the Perth Chest Clinic records from 1 January 1979 until 31 December 1987 were examined. There was a total of 101 cases of mesothelioma during this period. Of these, 9 cases were excluded because there was insufficient information regarding either the person's occupation or the duration of employment in a particular occupation. DOSHWA's Mesothelioma Register contains the names of a number of people who lived in Wittenoom but who did not

work in the mine or mill at ABA. There were eight such cases identified up until November 1985. The last group under consideration contained 16 workers. This group covered a wide variety of different occupations including carpenters, truck drivers and insulation workers. The mean duration of employment in this group was 176 months (range 1-420 months). The numbers of cases of mesothelioma amongst the different occupational groups described above, together with the mean durations of employment, standard deviations and ranges are summarized in Table I.

Lung Cancer

Of the 12 lung cancer patients who successfully claimed Workers' Compensation under the Act between July 1985 and 31 December 1987, 6 worked at ABA, 2 were Waterside Workers, 2 worked in the Railways, one for an Asbestos-Cement Products Manufacturer and one was an insulation worker. For the overall group of 12 lung cancer patients, the mean period of employment was 127 months (range 10-372 months). Of these 12 patients, all except for one (who gave a history of having been a lifelong non-smoker) had a history of moderate to heavy cigarette smoking over several years. Of the 11 smokers, it was possible in 10 of them to estimate the total cigarette consumption over their lifetime in terms of pack-years where one pack-year represents a person's smok-

ing a packet of 20 cigarettes per day for a year (=7300 cigarettes per year). The mean lifetime cigarette consumption was 37.7 pack years (range 18-56 pack years). The numbers of cases of lung cancer in the other occupational groups are listed in Table I along with the corresponding means, standard deviations and ranges.

Lung cancers attributable to asbestos exposure should, strictly-speaking, be called bronchial carcinomas, as should the vast majority of lung cancers that are caused by other known agents.¹ All the common histological forms can occur (squamous carcinoma, small or oat-cell carcinoma and 3 adenocarcinoma). Amongst the 12 cases of lung cancer considered in this paper, there were 4 adenocarcinomas, 4 small cell carcinomas, 2 squamous cell carcinomas, one case who had two separate tumours (one a squamous cell carcinoma and one a small cell carcinoma) and one case in whom the histopathological diagnosis was not recorded.

DISCUSSION

A widely held belief is that the increased risk of lung cancer due to exposure to asbestos occurs only where asbestosis is already present.² This theory contends that exposures to asbestos which are insufficient to cause asbestosis are also insufficient to cause lung cancer. The alternative point of view,

Table I
Numbers of Cases of Asbestosis/Silico-Asbestosis, Mesothelioma and Lung Cancer Amongst Different Occupational Groups with Mean Durations of Employment, Standard Deviations and Ranges (in Months)

	Asbestosis or Silico-asbestosis		Mesothelioma		Lung Cancer	
	N		N		N	
A.B.A.	N	14	N	61	N	6
	MEAN	43	MEAN	22.0	MEAN	39.3
	S.D.	25.1	S.D.	26.1	S.D.	46.8
	RANGE	3-96	RANGE	1-132	RANGE	10-133
RAILWAYS	N	5	N	5	N	2
	MEAN	223	MEAN	185	MEAN	94.5
	S.D.	180	S.D.	139	S.D.	36.1
	RANGE	72-504	RANGE	72-420	RANGE	69-120
ASBESTOS CEMENT PRODUCTS MANUFACTURING	N	9			N	1
	MEAN	231	NIL		MEAN	372
	S.D.	159			S.D.	N/A
	RANGE	28-416			RANGE	N/A
WATERSIDE WORKERS	N	9	N	8	N	2
	MEAN	235	MEAN	166	MEAN	264
	S.D.	111	S.D.	141	S.D.	102
	RANGE	84-384	RANGE	24-396	RANGE	192-336
OTHER	N	13	N	16	N	1
	MEAN	150	MEAN	176	MEAN	195
	S.D.	148	S.D.	137	S.D.	N/A
	RANGE	24-456	RANGE	1-420	RANGE	N/A
			N	90	N	12
			MEAN	71.1	MEAN	127
			S.D.	107	S.D.	125
			RANGE	1-420	RANGE	10-372

which is also widely held, is that there is no demonstrated threshold level of exposure to asbestos below which there is no increased risk of lung cancer.²

Chase et al (1985)³ have proposed, as its final determination, a "risk apportioned to asbestos" that is represented by a number between zero and one. This number reflects the strength of the evidence in support of each individual lung cancer being related to asbestos exposure. In 1984, Mowe et al⁴ analysed mineral fibre concentrations in lung tissue by scanning electron microscopy in 73 males with malignant mesothelioma and in 36 controls who died of cardiovascular or cerebrovascular diseases. Their investigation showed apparent differences in the median lung fibre concentrations between occupational groups with different levels of asbestos exposure as judged from their occupational histories. Mowe and Gylseth⁵ investigated 141 cases of malignant mesothelioma registered by the Cancer Registry of Norway 1970-79. Sixty-five of the cases were classified into four groups according to criteria of estimated probability of occupational asbestos exposure. These were definite, probable, possible and unlikely or unknown exposures.

In a survey undertaken by the Mines Department in 1966,⁶ measurements were made of the concentrations of airborne respirable fibres of crocidolite greater than 5 microns in length in various workplaces at ABA in Wittenoom. A 0 to 10 scale of estimated fibre levels for both before and after September 1957 (when a less dusty mill started operating) applicable to all 87 job categories at ABA was developed using the judgement of an ex-superintendent of operations at Wittenoom (who had a detailed knowledge of all jobs on the site throughout the production period). Unfortunately, as far as could be determined, there are no records of similar information concerning airborne fibre concentrations pertaining to non-ABA work situations which would have prevailed in Western Australia at the time that contemporary Workers' Compensation claimants would have been occupationally exposed to asbestos. The occupations of the six ABA workers who developed asbestosis and who worked in a single type of job category were compared with their scores on the above 0-10 point scale. Because of the small numbers involved, it is difficult to draw any conclusions from this comparison although it is interesting to note that two workers whose fibre concentrations were considered to be relatively low (2 points) still had sufficient exposure to cause asbestosis after only three years of employment in each case.

Any approach which attempts to uncover a relationship between different occupations and heaviness of asbestos exposure cannot take into account variations in how various processes are performed. In other words, such an approach is unable to make allowances for the fact that one type of operation can result in different degrees of exposure according to the ways in which the work processes are performed. It would be simple and convenient if, for cases of asbestos-induced occupational lung disease, one could look at the durations of employment of the workers in various occupations and operations and assume that there is an inverse relationship between duration of occupational exposure to asbestos and the

"heaviness" of exposure to asbestos entailed. If such an assumption were valid, one could then easily classify different occupations/operations according to the "heaviness" of exposure (e.g., heavy, moderate, mild, negligible, etc.). Unfortunately, there are a number of reasons why such an assumption would be invalid as well as a number of other difficulties with this approach. These include:

1. By utilizing Perth Chest Clinic records, one immediately introduces a form of selection bias, namely that patients with asbestos induced occupational lung disease who have not claimed Workers' Compensation are immediately excluded from further consideration.
2. There is a strong possibility of recall bias with respect to patients' recollections of their occupational histories.
3. The problem of multiple exposures refers to people who have been exposed to asbestos either in different occupations or who have performed different operations involving asbestos exposure while working in the same occupation.
4. The problem of intermittent exposure applies to the majority of cases where the information necessary to calculate an accurate equivalent continuous exposure was lacking.
5. The main problems encountered in recorded occupational histories were incomplete descriptions of jobs and incomplete information regarding the durations of exposure to asbestos.

CONCLUSION

A solution to this problem may be found in studies which compare the amounts of asbestos fibre measured in lung tissue for equivalent durations of asbestos exposure in different occupations. Until such time as the results of these types of studies become available, it will be necessary for medical panels charged with the responsibility of making judgements regarding "heaviness" of asbestos exposure to exercise clinical judgement and assess each case on its merits. Heaviness of exposure to asbestos can be thought of as the product of intensity and duration. This formula is not necessarily valid however because it does not separate the effects of the two variables.⁷ In the absence of any better alternative, it seems reasonable to make use of this formula, provided it is recognized that it may be an over-simplification of the true state of affairs. In determining the intensity of asbestos exposure in the absence of direct dust exposure measurements, one has to rely on an accurate description of the job to obtain an indirect indication of intensity. This can be partially corroborated by a knowledge on claimants who did similar jobs such as the subjective degree of dustiness of the working environment. The other parameter in the above formula is that of duration. In this regard the most important point to recognize is the distinction between duration of employment and duration of exposure. Apart from intensity and duration of exposure, the type of asbestos to which the claimant was exposed should be taken into account.

REFERENCES

1. Browne, K.: Is Asbestos or Asbestosis the Cause of the Increased Risk of Lung Cancer in Asbestos Workers? *Br. J. Ind. Med.* 43:145-149 (1986).
2. Acheson, E.D., Gardner, M.J.: *Asbestos. The control limit for Asbestos. Health and Safety Commission.* London: Her Majesty's Stationery Office (1983).
3. Chase, G.R., Kotin, P., Crump, K., Mitchell, R.S.: Evaluation for Compensation of Asbestos-Exposed Individuals 11. Apportionment of risk for lung cancer and mesothelioma. *J. Occup. Med.* 27:189-198 (1985).
4. Mowe, M.D., Gylseth, B., Hartveit, F., Skaug, V.: Occupational Asbestos Exposure, Lung-Fiber Concentration and Latency Time in Malignant Mesothelioma. *Scand. J. Work. Environ. Hlth.* 10:293-298 (1984).
5. Mowe, G., Gylseth, B.: Occupational Exposure and Regional Variation of Malignant Mesothelioma in Norway, 1970-79. *Am. J. Ind. Med.* 9:323-332 (1986).
6. Major, G.: Asbestos Exposure. In: Major, G. Ed.: Proceedings of the First Australian Pneumoconiosis Conference, Sydney. *Joint Coal Board:* 467-74 (1968).
7. Selikoff, I.J., Lee, D.H.K.: *Asbestos and Disease.* New York Academic Press (1978).

ACKNOWLEDGEMENTS: Dr. B. McGuirk, Chief Executive Officer, Department of Occupational Health, Safety, and Welfare, and the Workers' Compensation and Rehabilitation Commission of Western Australia, for permission to publish this paper. The views expressed in this paper are not necessarily those of DOSHWA or WCRC; Mr. R. Currie, Health Department of Western Australia for assistance with the perusal of the clinical records maintained by the Perth Chest Clinic; Mrs. J. Hay for typing the manuscript.

ASBESTOS EXPOSURE AMONG CONSTRUCTION WORKERS

NAOMI HISANAGA,* M.D. • Migiwa Hosokawa,† M.D., Ph.D. • Kiyoshi Sakai‡ • Eiji Shibata,* M.D. • Jian Huang,* M.D. • Yasuhiro Takeuchi,* M.D., Ph.D. • Yuichiro Ono,* M.D., Ph.D.

*Department of Hygiene, Nagoya University School of Medicine, Nagoya, Japan

†Department of Occupational Welfare, Kyoto Prefectural University, Kyoto, Japan

‡Department of Environmental Medicine, Nagoya City Health Research Institute, Nagoya, Japan

INTRODUCTION

During the past two decades, construction materials containing asbestos have occupied an important place in Japanese construction industry. At present, of total asbestos consumed per year, 199,000 tons (77.8%) are used for the construction materials¹ and there are approximately 4,800,000 construction workers in Japan.² It is presumed that a large percentage of the construction workers is exposed to asbestos and recently the health hazards by asbestos have caused concern. However, there are few reports about the asbestos exposure at construction work sites.^{3,4}

The objective of this study is to make clear the type of asbestos used in construction materials, the ambient asbestos concentration at construction work site and the working condition of workers handling asbestos-containing construction materials.

METHODS AND MATERIALS

Identification of Type of Asbestos

Asbestos-containing construction materials were randomly collected from construction work sites. Dust fractions for electron microscopic inspection were produced by scratching these construction materials with tweezers. Asbestos fibers of these samples were identified by transmission electron microscopy equipped with an energy dispersive X-ray analyzer.

Measurement of Ambient Asbestos Concentration

In order to evaluate the asbestos exposure level to the workers, dust concentrations in construction work sites were measured by the membrane filter method using phase contrast microscopy, according to the standard techniques of the Japan Association of Industrial Health for asbestos sampling and analysis. Particles $> 5 \mu\text{m}$ in length, $< 3 \mu\text{m}$ in diameter with an aspect ratio $> 3:1$ were counted.

Questionnaire Survey

The working conditions were surveyed by use of a self-completion questionnaire on all the 10,922 members of All Kyoto Construction Worker's Union in Kyoto prefecture,

Japan. The questionnaire included questions concerning sex, age, occupational category, duration of engagement in the present occupational category, use of asbestos-containing construction materials, asbestos dust exposure, protective and preventive measures, smoking history and respiratory subjective symptoms.

RESULTS

Type of Asbestos

Twenty four samples of asbestos-containing construction materials including 20 wall boards, two roofing materials, one vinyl asbestos floor tile and one sprayed wall material were collected from 22 construction work sites. Among 20 wall boards, chrysotile alone, amosite alone, and both were respectively detected from six, one, and 13 samples. From the remaining materials, only chrysotile was detected.

Asbestos Exposure Level

The asbestos concentrations in 59 spots of 17 construction work sites were measured during a variety of operations, e.g., sawing, screwing, drilling, nailing, cutting, filing of asbestos-containing construction materials. Electric hand tools were used in sawing, screwing and drilling. Airborne asbestos concentrations are shown in Table I. The personal exposure levels were measured in the breathing zone of the workers using personal dust sampler. The ambient asbestos-concentrations were measured in the center of the room. Fifty four dust measurements were made indoors and five were made outdoors. Neither local exhaust ventilation equipments nor general ventilation equipments were provided in any work sites where we visited.

Concerning the results of the indoor measurements, air samples taken in the breathing zone of the workers reached more than 100 f/ml during sawing of asbestos cement board with electric circular saw (Figure 1). The ceiling limit of threshold limit value of asbestos is 10 f/ml in Japan. The ambient asbestos concentrations during screwing (Figure 2), drilling, or nailing often exceeded the value, because sawing is sometimes done during these works. If not so, the ambient asbestos concentrations were relatively low ranging from 0.3 to 14.1 f/ml. Table I also showed that the workers near the ones handling asbestos-containing materials are exposed to

Table I
Ambient Asbestos Concentrations in Construction Work Sites

Operations	Number of samples	Sampling time (min)		Concentrations (f/ml)		
		Range	Mean ¹	Range	Mean ²	Median
[Indoor Work]						
Sawing ^a	4	2.5-5	3.8	125-787	214	147
1.5-2m from the above work ^a	3	2.5-5	3.5	103-630	245	232
Screwing or drilling or nailing ^a (partly include sawing)	8	10-120	48	1.3-131	11.0	12.3
1-10m from the above work ^a	7	10-119	56	0.9-48.1	5.4	3.0
Screwing or drilling or nailing ^a (not include sawing)	8	2.6-110	48	0.3-14.1	2.0	2.5
1-4m from the above work ^a	15	15-171	87	0.1-4.6	1.3	1.6
Cutting and filing ^a	1	1.0	-	12.1	-	-
Inspecting work site ^a (5-30m from the work operating asbestos board)	2	68-93	-	0.04-0.12	-	-
Finishing or cleaning ^a (1 to 7 days after the work using asbestos board)	5	15-93	45	0.1-0.5	0.3	0.3
Center of room ^b (a day after the work using asbestos board)	1	110	-	0.01	-	-
[Outdoor Work]						
Sawing ^a	1	124	-	0.14	-	-
Roofing ^a	1	115	-	0.13	-	-
1-2m from the above work ^a	1	115	-	0.05	-	-
Nailing on exterior wall board ^a	1	117	-	0.13	-	-
Plumbing ^a (a day after the work using asbestos board)	1	160	-	0.05	-	-

1: arithmetic mean, 2: geometric mean

a: Personal samples were collected. b: Area sample was collected
Sawing: with an electric circular saw, Screwing: with an electric screw driver, Drilling: with an electric drill, Nailing: with a hammer, Cutting: with a knife,

asbestos. The cleaning of the work sites was insufficient that ambient asbestos concentrations were from 0.1 to 0.5 f/ml after the use of asbestos wall board (Figure 3).

The outdoor ambient asbestos concentrations ranged from 0.05 to 0.14 f/ml.

Working Conditions

6549 (60.0%) out of 10,922 workers belonging to All Kyoto Construction Worker's Union completed the questionnaire. Among them, male and female workers were 6500 (99.3%) and 49 (0.3%), respectively. In the following analysis, female workers were excluded because the number was very small.

The age of male respondents ranged from 17 to 84 years (mean 44.6, SD 11.0).

The distribution of the present occupational categories is shown in Table II. More than 40 kinds of trade categories were reported. Carpenters held a majority (40.8%) followed by plasterers (8.3%), electricians (4.4%), painters (4.1%) and plumbers (3.3%). The mean duration of engagement was 22.8 years (SD 11.4, range 0.2-65).

The number of workers who *often* handled asbestos-containing construction materials were 1360 (20.9%) and who handled *sometimes* were 2449 (37.7%). The distribution of the construction materials used by these workers is shown in Table III. Asbestos slate board was the most popular material, asbestos silicate-calcium board the next. Table IV illustrates the distribution of duration of handling asbestos-containing construction materials. The duration of handling ranged from less than one to 52 years (mean 14.1, SD 8.0). The distribution of mean number of days of handling asbestos-containing materials per month in the last one year is shown in Table V. Median value was 3 days per month.

Since construction workers have been not only directly exposed but also indirectly exposed to asbestos dust emitted by



Figure 2. Fixing wall board to metal studs with screws by electric screw driver.

other workers in the work sites, the frequency of asbestos exposure either directly and indirectly was surveyed. The results are shown by main construction trade categories in Table VI. The frequency was varied by trade categories. Among them



Figure 1. Sawing asbestos-containing wall board with electric circular saw without local exhaust ventilation equipment. Ambient air was highly contaminated by asbestos.



Figure 3. A: Floor contaminated by asbestos-containing dust after sawing wall board. B: Sweeping floor with a broom. One can see the secondary asbestos dust emission.

Table II
Distribution of Occupational Categories

	Number of workers	
carpenter	2608	(40.8%)
plasterer	531	(8.3%)
electrician	280	(4.4%)
painter	261	(4.1%)
plumber	220	(3.4%)
navvy	209	(3.3%)
sheet metal worker	197	(3.1%)
interior finish worker	147	(2.3%)
steel-frame worker	129	(2.0%)
cabinet maker	126	(2.0%)
helper	118	(1.8%)
tiler	104	(1.6%)
others	1466	(22.6%)
no answer	104	(1.6%)
total	6500	(100.0%)

Table IV
Distribution of Duration of Handling Asbestos-containing Construction Materials (N=2501)

Duration (years)	Number of workers	
0< - 4	258	(10.1%)
5- 9	492	(19.7%)
10- 14	705	(28.3%)
15- 19	416	(16.7%)
20- 24	383	(15.4%)
25- 29	124	(5.0%)
30- 34	91	(3.6%)
35- 39	24	(1.9%)
40- 52	8	(0.3%)

Table III
Distribution of Numbers of Workers Using Asbestos-containing Construction Materials (N=3782)

	Number of workers	
[Materials containing asbestos]		
asbestos slate board	2431	(64.3%)
asbestos silicate-calcium board	1747	(46.2%)
heat insulating asbestos pad	697	(18.4%)
asbestos roofing materials	639	(16.9%)
asbestos cement parlite board	600	(15.9%)
sprayed asbestos	478	(12.6%)
parlite board	429	(11.3%)
asbestos felt	336	(8.9%)
asbestos pipe	312	(8.2%)
asbestos paper laminated plywood	266	(7.0%)
asbestos packing	255	(6.7%)
asbestos cloth and yarn	230	(6.1%)
rubber asbestos sheet	184	(4.9%)
asbestos gasket	119	(3.1%)
asbestos tape	118	(3.1%)
asbestos rope	89	(2.4%)
asbestos-containing paint	72	(1.9%)
[Materials which contain asbestos or do not varies with the kind of productions]		
wood wool cement board	1438	(38.8%)
vinyl asbestos floor tile	1173	(31.0%)

carpenters were most frequently exposed to asbestos.

As for the use of protective mask, 28 (0.8%) workers out of 3710 workers who have an experience in using asbestos-containing construction materials responded to use it *everytime* and 216 (6.6%) answered *sometimes*.

There were 2491 smokers (66.4%), 670 ex-smokers (17.9%) and 588 non-smokers (15.7%) among the workers who have an experience in using asbestos-containing materials.

The relationship between the mean days of handling asbestos-containing construction materials per month in the last one year and the prevalence of respiratory subjective symptoms (palpitation, shortness of breath, cough and sputum) is shown in Table VII. The prevalence of the symptoms increased with the mean asbestos-handling days per month. The correlation coefficients between the rank of mean days per month and the prevalence of the symptoms ranged from 0.080 to 0.206 ($p < 0.0001$, Kendall's tau-C), while the correlation coefficients between the rank of mean days per month and smoking habit or age were not significant.

DISCUSSION

The present study resulted in the following:

1. Not only chrysotile but also amosite are frequently used for the construction materials.
2. Ambient asbestos concentrations in the worker's breathing zone widely ranged from 0.04 to 787 f/ml depending on the kinds of work and the ventilatory conditions. Indoor sawing with electric circular saw was considered as one of the most hazardous operations.
3. A great number of construction workers are exposed to asbestos without appropriate countermeasures.
4. Of the workers handling asbestos-containing materials, 66.4% were the co-exposed to asbestos and smoking.

5. The prevalence of the respiratory subjective symptoms increased as the frequency of handling asbestos-containing materials increased.

There has been a paucity of literature dealing with the actual conditions of asbestos exposure among construction workers.

Fischbein et al. surveyed the asbestos exposure in the drywall construction trade in the United States. Of 15 industrial drywall taping and spackling compounds, they found chrysotile in nine, tremolite in one, and both in three, respectively. They showed that asbestos concentrations in the breathing zone of drywall tapers ranged 1.2-19.3 f/ml during pole sanding, 1.3-16.9 f/ml during hand sanding and 35.4-59.0 f/ml during dry mixing of taping compounds, respectively.³

Verma and Middleton investigated the asbestos concentrations in various operations of the drywall taping process in the province of Alberta, Canada. They showed that the asbestos concentrations in the breathing zone of workers ranged 1.2-12.4 f/ml during mixing, 1.2-24.2 f/ml during sanding and 4.0-26.5 f/ml during sweeping, respectively.⁴

Table V

Distribution of Mean Number of Days of Handling Asbestos-containing Construction Materials per Month in the Last One Year (N=1708)

day/month	Number of workers
0<-<1	47 (2.4%)
1- 2	710 (36.6%)
3- 4	399 (20.6%)
5- 6	279 (14.4%)
7-10	314 (16.2%)
11-15	116 (6.0%)
16-30	76 (3.9%)

Table VI

Asbestos Exposure by Occupational Categories

	Number of workers	Asbestos exposure	
		often	sometimes
carpenter	2608	15.0%	43.4%
sheet metal worker	197	5.6	32.5
plumber	220	8.2	26.8
electrician	280	7.5	27.5
plasterer	531	4.1	27.5
helper	118	5.0	21.0
interior finish worker	147	6.1	17.7
steel-frame worker	129	3.1	20.9
painter	261	3.8	19.2
cabinet maker	126	0.8	13.5
navvy	209	2.4	11.5
tiler	104	1.9	11.5
total	6500	8.9	29.1

Table VII
 Relationship Between Mean Days of Handling
 Asbestos-Containing Materials per Month in the Last One Year
 and Prevalence of Respiratory Subjective Symptoms

day/month number	number	palpitation			shortness of breath		
		often	sometimes	total	often	sometimes	total
0	1141	0.8%	16.5%	17.3%	2.2%	16.7%	18.9%
0<-<1	42	2.4	16.7	19.1	0	19.0	19.0
1- 2	642	2.8	19.2	22.0	3.7	19.5	23.2
3- 4	366	2.2	21.9	24.1	2.5	27.0	29.5
5- 6	254	3.5	24.0	27.5	4.7	24.0	28.7
7-10	296	3.4	24.3	27.7	5.7	24.3	30.0
11-15	108	4.6	23.1	27.7	5.6	23.1	28.7
16-30	69	7.2	31.9	39.1	8.7	30.4	39.1

day/month number	number	cough			sputum		
		often	sometimes	total	often	sometimes	total
0	1141	3.3%	24.4%	27.7%	7.8%	25.6%	33.4%
0<-<1	42	2.4	31.0	33.4	4.8	38.1	42.9
1- 2	642	5.8	37.7	43.5	10.9	39.3	50.2
3- 4	366	7.4	41.5	48.9	13.4	42.1	55.5
5- 6	254	15.0	40.7	55.7	20.5	39.4	59.9
7-10	296	11.8	40.5	52.3	17.9	39.2	57.1
11-15	108	14.8	46.3	61.1	19.4	42.6	62.0
16-30	69	13.0	50.7	63.7	23.2	40.6	63.8

In Japan, no data on the asbestos exposure among workers during handling asbestos-containing boards at construction work sites has been reported in the literature. According to the present study, it was considered that the asbestos dust emission during indoor sawing with electric circular saw was larger than that of drywall taping process.

There are several reports on the health effect of asbestos exposure among the construction workers.^{3,5-7} Fischbein et al. reported that pleural thickening was found in 8% of the 109 drywall tapers.³ Hedenstierna et al. reported that 62% of the 423 construction workers who had been registered as exposed to asbestos had radiological evidence of pleural plaques in Sweden.⁵ Ebihara et al. described that 1.27% of 3613 construction workers of over 40 years old had evidence of pleural plaques on chest X-ray, while none of 845 office workers had such evidence.⁶ Nicholson et al. estimated that 2143 asbestos-related cancer deaths occurred in 1982 and these would rise to about 3400 annual deaths by the year 2000 among construction workers in USA.⁷ The present study suggested that the prevalence of respiratory subjective symptoms elevated dose-dependently. The medical surveillance of workers who participated in the present study is now ongoing.

SUMMARY

The actual condition of asbestos exposure among construction workers were surveyed. It was made clear that workers

were exposed to high concentrations of asbestos without local exhaust ventilation equipment and respiratory protective equipment. On the basis of this study, there is urgent need to work out a sufficient countermeasure minimizing asbestos exposure in construction work sites.

REFERENCES

1. According to the data of Japanese association of Asbestos. (1986).
2. 1986 Establishment Census of Japan, Vol. 1, Results for Japan, Part 1, Division 1, pp 2-3, Statistics Bureau, Management and Coordination Agency, Tokyo (1987).
3. Fischbein, A., Rohl, A.N., Langer, A.M., Selikoff, I.J.: Drywall Construction and Asbestos Exposure. *Am. Ind. Hyg. Assoc. J.* 40:402-407 (1979).
4. Verma, D.K., Middleton, C.G.: Occupational Exposure to asbestos in the drywall taping process. *Am. Ind. Hyg. Assoc. J.* 41:264-269 (1980).
5. Hedenstierna, G., Alexanderson, R., Kolmodin-Hedman, B., Szamosi, A., Tollqvist, J.: Pleural Plaques and Lung Function in Construction Workers exposed to Asbestos. *Eur. J. Respir. Dis.* 62:111-122 (1981).
6. Ebihara, I., Kawami, S.: Pleural Plaques among Construction Workers. Presented at the 61st Annual Meeting of Japan Association of Industrial Health, held on 11-14 April, 1988, in Kanazawa, Japan.
7. Nicholson, W.J., Perkel, J., Selikoff, I.J.: Occupational Exposure to Asbestos: Population at Risk and Projected Mortality-1980-2030. *Am. J. Ind. Med.* 3:259-311 (1982).

ACKNOWLEDGEMENTS: We wish to thank members belonging to All Kyoto Construction Worker's Union and Mie Prefecture Construction Worker's Union for their cooperation in the field investigations and the questionnaire investigation.

DUST EXPOSURE RESULTS IN 359 ASBESTOS-USING FACTORIES FROM 26 COUNTRIES

DANIEL BOUIGE

Association Francaise de L'Amiante 10
rue de la Pépinière 75008 PARIS (France)

Mr. Chairman,
Ladies and Gentleman,

PART I: DESCRIPTION OF THE SURVEY

It is a great pleasure for me to present, on behalf of the Asbestos International Association (A.I.A.) and for the first time at an international scientific conference, the results of an inquiry carried out from investigations in the member countries of this Association. The prime object of A.I.A. is to encourage protective measures to eliminate risks to health arising from exposure to asbestos and I believe that such an inquiry is also a helpful part of the motivation and the emulation necessary to achieve it.

The 1986 survey is the third one so conducted by sending out a questionnaire prepared by an A.I.A. Dust Advisory Panel (D.A.P.) including experts in the field of industrial hygiene. For 1986, twenty-six members out of 32 (Figure 1) provided useful figures, which is an increase of 3 as compared with the previous returns.

Furthermore, another inquiry was carried out in order to evaluate the representativity of the survey. This was achieved through a comparison between the number of asbestos workers whose exposure is known and the total number of asbestos workers exposed among the company members from 24 national associations. Altogether about 75% of the factories within the national associations took part in the inquiry, which corresponds respectively to 78% of the asbestos workers. Of

course, one should remain very cautious on such an evaluation as there is obviously no one national or international binding rule for a company to become a member or take part in the activities of an industry association. This point is primarily important to consider in connection with some of the small but numerous companies using asbestos at some stage and which are usually not members of the national asbestos association.

As a conclusion of this first part of my presentation I wish to say that our prime objective remains that all the A.I.A. members should be very soon in a position to contribute to the survey.

As we shall see during the second part of my talk, significant progress has already been achieved on the issue. However, as an introductory warning to that second part, I must point out that the results which I am going to present now cannot be extrapolated to become a worldwide picture of the situation and should be cautiously understood within the limited investigations that any national association may undertake in this field.

Also, I would like to mention that an annual detailed report of the survey is distributed by A.I.A. to all its members, disclosing their individual code country number.

Within the limited time which is left now, I shall try to comment on the main findings so far available.

ARGENTINA	GERMANY	NIGERIA
AUSTRIA	GREECE	REP. OF SOUTH AFRICA
BELGIUM	INDIA	SPAIN
BRAZIL	IRELAND	SWEDEN
CANADA	ISRAEL	SWITZERLAND
CHILE	JAPAN	UNITED KINGDOM
DENMARK	KENYA	U.S.A.
FINLAND	MEXICO	ZIMBABWE
FRANCE	NETHERLANDS	

Figure 1. Countries contributing to the 1986 survey.

PART TWO: EVALUATION AND RESULTS OF THE SURVEY

Five categories of asbestos activities have been selected and classified into the following groups:

- Manufacturing of asbestos containing products (including asbestos cement, friction materials, textiles and others)
- Asbestos production (mines, mills)

Figure 2 shows the number of factories contributing to the 1984, 1985 and 1986 survey respectively for the various activities described above. Altogether, a significant improvement has been achieved since the initial 1984 survey (130/302/359) and it can be anticipated that this trend will be confirmed through the next inquiries.

Looking now at the corresponding numbers of asbestos workers (Figure 3) whose exposure results will be described later on, more significant progress in the 1986 returns can be

observed with 45,696 results available which is a one third increase as compared with the previous year. Most of the results originate from the asbestos production activity, the asbestos-cement and the friction material product group.

SAMPLING AND COUNTING STRATEGIES

The method used for monitoring of the workplace is always the so-called "membrane filter method" allowing for a fibre counting among the particles deposited onto a filtering media after sampling of a determined air volume during the working time.

Several international initiatives (such as ISO and the EEC) have been undertaken to harmonize the various procedures applied and even though some few divergencies remain, these are in general much less consequent upon the results than variations due to the sampling strategies themselves.

As shown in Figure 4, most samples are personal samples,

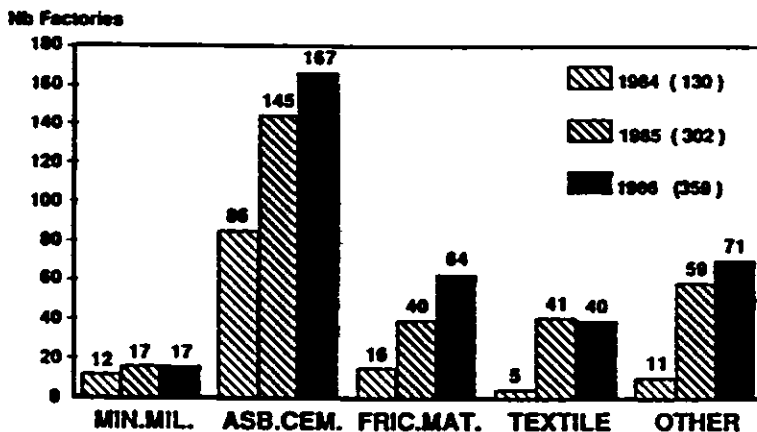

Figure 2. Number of factories covered by the A.I.A. survey (from 1984 to 1986).

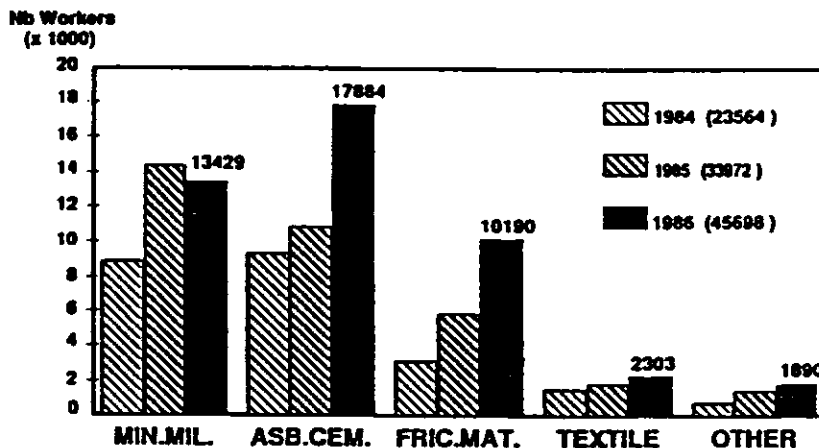

Figure 3. Number of workers covered by the A.I.A. survey (from 1984 to 1986).

but the proportion of static samples still remains rather important mainly for the asbestos-cement group as well as for the mines.

The survey has also revealed further observations pointing out that the sampling strategies have been different among the factories and/or countries. These variations originate mainly from the selection of a workplace to become representative of a job group as well as from the annual sampling frequency in use. In order to reduce the main divergencies on these matters, some recommendations have been prepared by the Dust Advisory Panel of A.I.A.; however, it should be acknowledged that defining and harmonizing the sampling strategies

in general remains a rather complex issue.

It is probably through a periodic exchange of views with the main partners involved on the working site that the best practical decision will be achieved in the future.

RESULTS OF INDIVIDUAL EXPOSURE

Figure 5 illustrates the global situation among 45,696 workers from 359 factories included in the survey.

At this stage no distinction was made between the various product groups and the data were simply distributed within

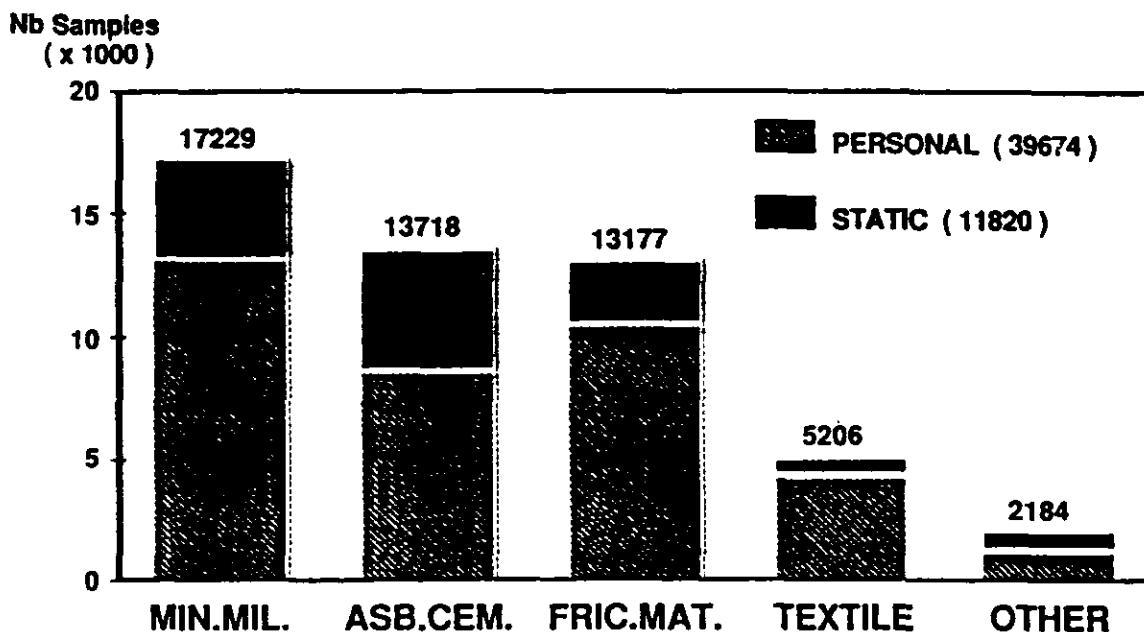

Figure 4. Yearly personal and static samples (total number by product group).

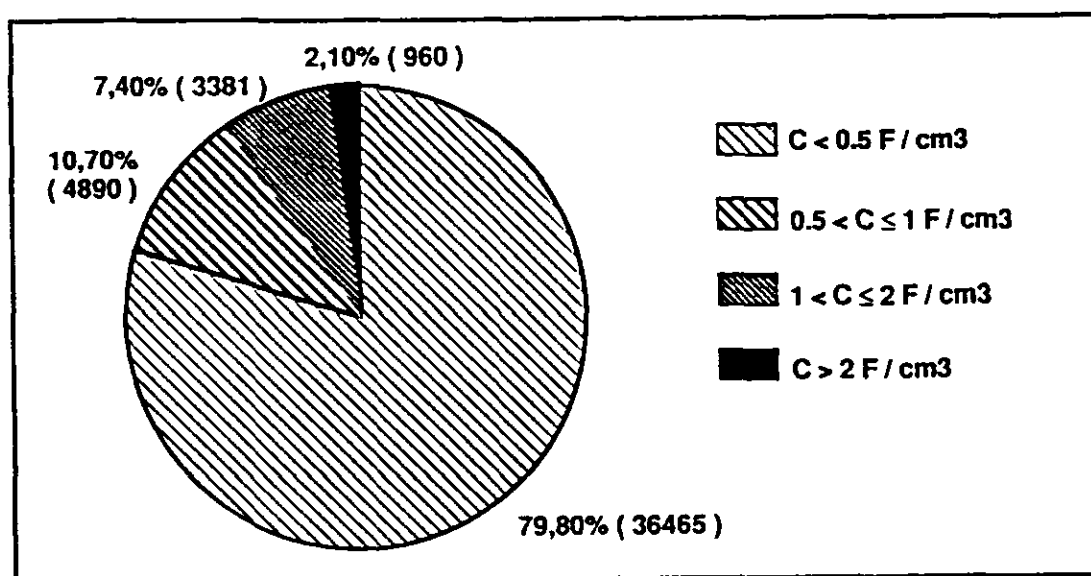

Figure 5. Asbestos worker exposure—1986 (26 countries—45,696 workers under survey).

four ranges.

$C < 0.5$ f/ml	79.8%
$0.5 < C \leq 1$ f/ml	10.7%
$1 < C \leq 2$ f/ml	7.4%
$C > 2$ f/ml	2.1%

By reference to a 1 f/ml T.L.V. currently often adopted, it can be seen that it is effectively enforced for more than 90% of the workers.

By reference to a 2 f/ml T.L.V. which had been the first international guideline recommended by an I.L.O. group of experts in 1973, it can be seen that a little more than 2% of the workers have an asbestos exposure above this value.

Figures 6 to 10 evaluate more specifically the mean situation observed in the various industrial activities.

The mines and mills group (Figure 6) has provided A.I.A. with results:

- for 13,499 workers,

- in 17 production sites
- from 6 countries

showing:

- 82.6% of results < 1 f/ml
- 16.0% of results between 1 and 2 f/ml
- 1.4% of results > 2 f/ml

The asbestos-cement group (Figure 7) has provided A.I.A. with results:

- for 17,884 workers,
- in 167 factories
- from 23 countries

showing:

- 95.5% of results < 1 f/ml
- 3.3% of results between 1 and 2 f/ml
- 1.2% of results > 2 f/ml

The friction material group (Figure 8) has provided A.I.A.

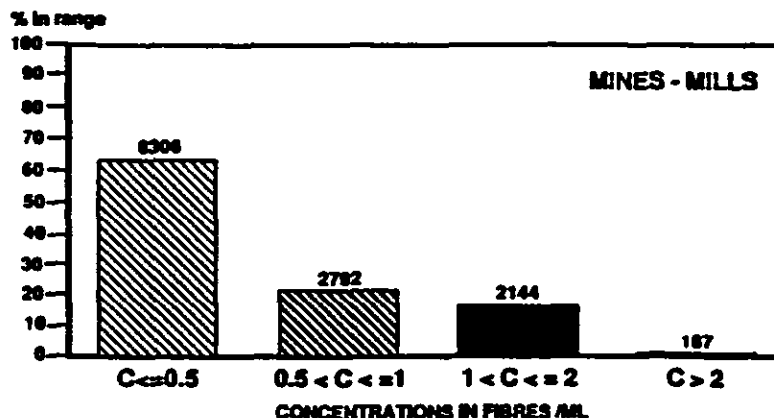

Figure 6. Asbestos exposure of workers under survey (6 countries—17 sites—13,429 workers).

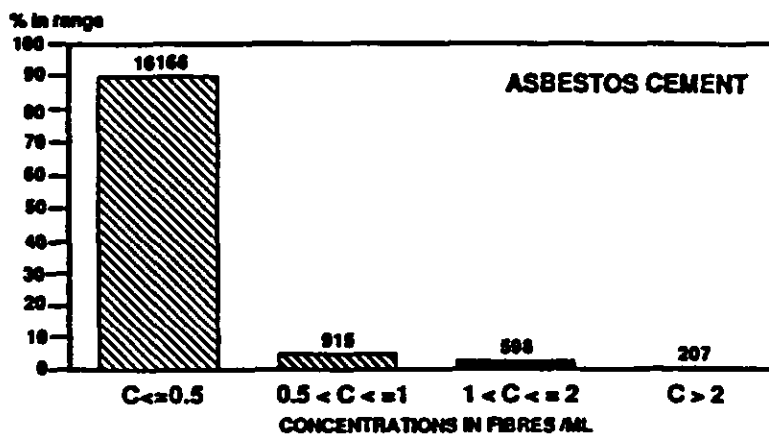

Figure 7. Asbestos exposure of workers under survey (23 countries—167 factories—17,884 workers).

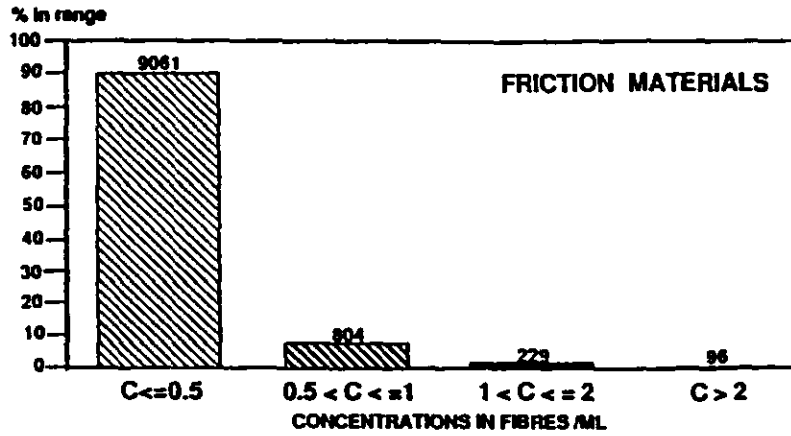

Figure 8. Asbestos exposure of workers under survey (10 countries—64 factories—10,190 workers).

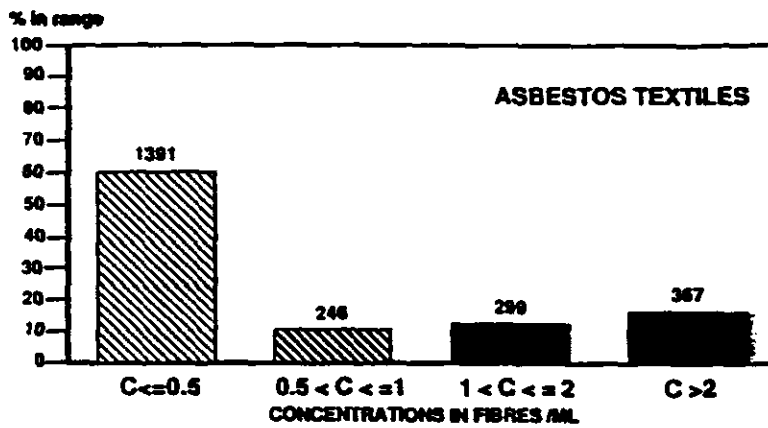

Figure 9. Asbestos exposure of workers under survey (7 countries—40 factories—2,303 workers).

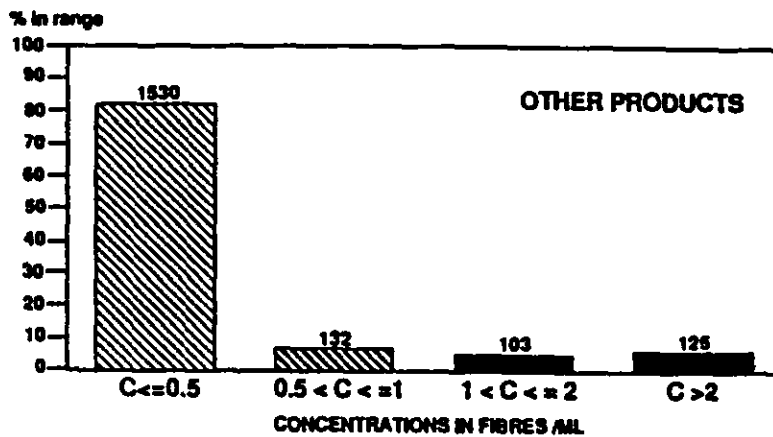

Figure 10. Asbestos exposure of workers under survey (10 countries—71 factories—1,890 workers).

with results:

- for 10,190 workers,
- in 64 factories
- from 10 countries

showing:

- 96.8% of results < 1 f/ml
- 2.2% of results between 1 and 2 f/ml
- 1.0% of results > 2 f/ml

The textile group (Figure 9) has provided A.I.A. with results:

- for 2,303 workers,
- in 40 factories
- from 7 countries

showing:

- 71.1% of results < 1 f/ml
- 13.0% of results between 1 and 2 f/ml
- 15.9% of results > 2 f/ml

The other products group (Figure 10) has provided A.I.A. with results:

- for 1,890 workers,
- in 71 factories
- from 10 countries

showing:

- 87.9% of results < 1 f/ml
- 6.1% of results between 1 and 2 f/ml
- 6.0% of results > 2 f/ml

By comparison, as shown in Figure 11, it can be observed that the textile activities involved in the survey generate the widest

distribution of results with a proportion above 1 f/ml about three times higher than the mean (29.9% against 10%) and still much higher when compared with each one of the groups.

In practice, when looking at the textile situation among the limited number of countries which provided results for this product group, it can be assumed that the workers' exposure levels remain highly contrasted in this activity.

With more time available it would have been possible to show more detailed information extracted from this survey. However, I believe that this talk was sufficient to underline the most interesting aspects of such an inquiry. I just wish to add that further work is being carried out in this connection, mainly to improve the reliability of the data collected.

These are relevant on the one hand to the sampling strategies as I mentioned before and to the fiber counting activities on the other hand through an annual microscope international slide exchange and the preparation of specific training slides.

Finally, before closing my speech, I would not like to conclude without pointing out again the most important warning which I made at the beginning: although we feel quite convinced that this A.I.A. report is a major step ahead towards the improvement in the protection against the risks arising from exposure to asbestos, those results are still not complete enough to allow their extrapolation, in one way or the other, to all situations where asbestos can be used in most countries around the world.

The non existence of results might well be an indication that the risks are simply ignored, which should then be imperatively reversed and any further relevant existing results made available to A.I.A. to improve the quality of this survey will certainly be most appreciated and useful.

Thank you for your attention.

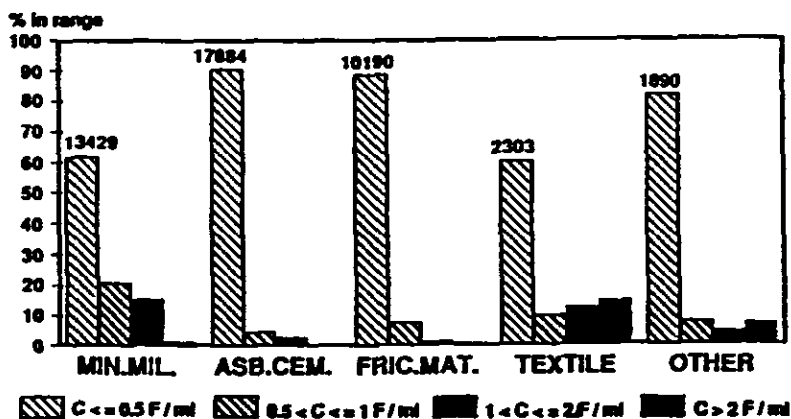

Figure 11. Asbestos exposure of workers under survey (26 countries—359 factories—45,696 workers).

DISCRIMINATING AMPHIBOLE CLEAVAGE FRAGMENTS FROM ASBESTOS: RATIONALE AND METHODOLOGY

A.G. WYLIE, Ph.D.

Laboratory for Mineral Deposits Research, Department of Geology, University of Maryland, College Park, Maryland 20742, USA

INTRODUCTION

Amphiboles, especially tremolite and actinolite, are major rock-forming minerals and are common in many industrial mineral products including crushed stone, vermiculite, industrial talc, playsand, and other special use products. Most epidemiological and experimental data support the conclusion that amphibole cleavage fragments are not carcinogenic^{1,2} while it is well established that amphibole asbestos can be a potent carcinogen. Nonetheless, OSHA continues to keep the question of the carcinogenicity of cleavage fragments open.³ It is my contention that uncharacterized or poorly characterized samples remain at the heart of this disagreement. In this paper I will describe the unique mineralogical properties and dimensions of asbestos, paying particular attention to tremolite-asbestos, actinolite-asbestos and other varieties of these minerals. Despite the fact that mineralogists have urged health scientists to be more precise in the descriptions of minerals used in experiments, there still remains the need to ask again.

DEFINITIONS

Asbestos is defined by the Glossary of Geology⁴ as "a commercial term applied to a group of highly fibrous silicate minerals that readily separate into long, thin, strong fibers of sufficient flexibility to be woven, are heat resistant and chemically inert, and possess a high electrical insulation and therefore are suitable for uses where incombustible, nonconducting or chemically resistant material is required." (p.41) Heat resistance, chemical inertia and high electrical insulation are properties of almost all silicates and are therefore not unique to asbestos. However, long, thin, strong, flexible fibers are limited almost exclusively to asbestos and define the asbestiform habit. This definition is based on the commercial properties that made asbestos use so widespread. Dana, however, defines asbestos based only on mineralogical properties as follows: "Tremolite, actinolite and other varieties of amphibole pass into fibrous varieties, the fibers of which are sometimes very long, fine, flexible and easily separable by the fingers and look like flax. These kinds are called asbestos."⁵ Dana also noted that there are varieties of amphibole that are very similar to asbestos but lack the flexibility of asbestos. He called this material byssolite.⁵ Byssolite is too stiff to weave into cloth so according to both definitions it is not asbestos.

The word asbestiform has been used in the epidemiological

literature and to describe the minerals found in commercial products in many ways. It has been applied to mean asbestos and to describe minerals such as tremolite that are not asbestos but may sometimes occur in nature as asbestos. This contradictory use of the term has rendered it almost useless. This is extremely unfortunate because the mineralogical definition of asbestiform could have great utility in the literature that deals with the carcinogenicity and fibrogenicity of mineral fibers. In fact, until precise mineralogical terminology is employed in describing minerals used in biological experimentation, the results of such experiments cannot be used to generalize about the health effects of mineral size, shape, chemical composition or habit.

In the mineralogical sense, the term asbestiform can be defined under the microscope by the following characteristics:

1. mean aspect ratio of 20:1 or greater for fibers longer than 5 micrometers,
2. very thin fibrils, usually less than 0.5 micrometers in width, and
3. two or more of the following:
 - a. parallel fibers occurring in bundles,
 - b. fiber bundles displaying splayed ends,
 - c. fibers in the form of thin needles,
 - d. matted masses of individual fibers, and
 - e. fibers showing curvature.

This definition is based on the mineralogical properties and dimensions of both commercial and non-commercial asbestos which are described in the following sections.

MINERALOGICAL PROPERTIES OF ASBESTIFORM MINERALS

Fibrillar Structure

Asbestos of all types is composed of bundles of individual fibrils. These fibrils vary in size among the different asbestos types and occurrences. South African and Australian crocidolite has a fibril that ranges in width from about 500 to 2000 Å; grunerite-asbestos from South Africa ranges from about 2000-6000 Å and chrysotile fibrils from most localities range from about 200 to 500 Å in width.⁶ Actinolite-asbestos, tremolite-asbestos and anthophyllite-asbestos have fibril widths that are comparable to South African amosite. The width of byssolite fibers may range up to ten micrometers or more.

Asbestos fibrils share a common axis of elongation but are randomly oriented with respect to the other crystallographic directions. There have been reports of other minerals forming between fibrils (talc, brucite), but generally asbestos fibers are monomineralic. The fibrils are held together by weak bonds and the fibrils are easily separated by gentle pressure of the hand. Separation of the fibrils in this manner is not cleavage; no structural bonds are broken.

The fibrillar structure of asbestos hinders the use of single crystal X-ray techniques to study it. Instead of producing a pattern of spots which can be interpreted to determine symmetry and structure, an asbestos fiber with a diameter of about 0.1 mm will produce a pattern consisting of lines derived from spot patterns of thousands of individual fibrils that share only one crystallographic axis in common. For many years, the inability to study asbestos by classical X-ray techniques left the determination of symmetry to the optical properties (which also are affected by the fibrillar structure), and the common amphibole-asbestos crocidolite and amosite were thought to be orthorhombic rather than monoclinic which they are now known to be.⁷

Monoclinic amphiboles exhibit the property of oblique extinction when viewed under the petrographic microscope. This property arises because the principal optic directions (X, Y, and Z) are not parallel to the principal crystallographic axes (a, b, and c). Oblique extinction is found in minerals that belong to the monoclinic and triclinic crystal systems, but is lacking in minerals that are orthorhombic, hexagonal or tetragonal. Minerals of the latter group exhibit parallel extinction. However, all types of asbestos exhibit parallel extinction, regardless of the crystal system to which they belong. This arises because the individual fibrils are smaller than the resolution of the light microscope so that their properties cannot be examined individually. Instead, a group is always observed. In some samples of asbestos, some individual fibrils approach 1 μm in width. These fibrils should show the properties characteristic of the crystal system to which they belong. In some specimens, notably those with low tensile strength, they do; but in others, they do not. Amosite, for example, has fibrils that approach 5000 Å. These are large enough to be seen optically. However, they always exhibit anomalous parallel extinction. {100} twinning is very common in amphibole asbestos, and if pervasive, could account for this anomalous behavior.^{8,9,10}

It should be mentioned that the peculiar optical properties of asbestos have been recognized for many years. Deer et al.¹¹ state that amosite and crocidolite have parallel extinction. Heinrich¹² explains the parallel extinction of asbestos in terms of its fibrillar structure and points out that tremolite-asbestos was originally identified as anthophyllite because of its optical properties.

Tensile Strength

The high tensile strength of asbestos is clearly related to the fibrillar structure. Asbestos has a 10 to 30-fold increase in tensile strength over nonasbestos forms of the same minerals. In the case of the amphiboles, the tensile strength varies inversely with the fibril width.^{7,12} This means that the tensile strength

of South African crocidolite is greater than that of the South African amosite which in turn has a tensile strength greater than Finnish anthophyllite.

Zoltai¹³ has suggested that the high tensile strength is related to the surface structure of the fibrils as well as to their width. Under the scanning electron microscope, the mirror-like surfaces of asbestos are evident. They lack cracks and other imperfection that contribute to a decrease in the ideal tensile strength. By contrast, cleaved fragments of the same mineral usually have rough, irregular surfaces. It has been known for many years that the strength of a fiber is inversely proportional to the diameter. According to Zoltai¹³ this is often related to an increased strength of the surface structure of fibers which becomes increasingly important as diameter decreases.

Crystal Forms

Cleavage in amphiboles takes place along the {110} surfaces ({210} in the orthoamphiboles). Therefore, most amphibole particles that have been cleaved are bounded by these surfaces. However, some amphiboles may also exhibit parting along {100} and/or {010}. Parting in common amphiboles is not usually well developed so amphibole fragments are bounded by these surfaces only rarely.

By contrast, amphibole asbestos fibrils are frequently bounded by {100}, {010}, and {110} faces with {100} being the most well developed, providing lath-like fibers.^{10,14} Dorling and Zussman¹⁰ conclude that these are generally growth surfaces, not cleavage planes, although twinning on {100} is common in amphibole asbestos and parting may contribute to the development of this surface.

THE SIZE AND SHAPE OF ASBESTOS FIBERS

Bulk Samples

Length, width, and aspect ratio distributions of populations of bulk samples of many types of asbestos have been determined.^{6,16,17,18,19,20,21} To some extent the dimensional characteristics of these populations are dependent on the sample preparation techniques, primarily the degree of grinding. However, except under the most extreme conditions, when grinding has been so prolonged that the particles are reduced to nearly equidimensional masses, certain characteristics of asbestos are retained. For example, sample preparation disaggregates asbestos fibers and, to a greater or lesser degree, separates individual fibrils. However, because the width of a fibril is established during the formation of asbestos and because of the high tensile strength of asbestos, the widths of asbestos fibers are not easily altered. Another dimensional characteristic that is normally unaffected by sample preparation is the relationship between width and length.²² The width of an asbestos fiber is essentially independent of its length while for populations of cleavage fragments, as the length of a particle increases, so does its width.¹⁷ (Mixed populations will show characteristics between these two.) Aspect ratio has been used frequently to characterize mineral particle populations. However, to be used effectively, aspect ratio comparisons must be restricted to particular ranges in length.

Table I gives the width and aspect ratio distributions of fibers

Table I
Commercial Asbestos—Width Distribution

	(a)	(b)	(c)
	<u>% longer than 5μm</u>	<u>% of (a) with widths < 1.0μm</u>	<u>% of (a) with widths < 0.5μm</u>
crocidolite South Africa	48	98	85
amosite South Africa	73	91	50
chrysotile Quebec	38	99	94
chrysotile (SEM) California	54	98	94
chrysotile (TEM) California	8	100	98

COMMERCIAL ASBESTOS - ASPECT RATIO DISTRIBUTION

	(a)	(b)	(c)	(d)
	<u>% longer than 5μm</u>	<u>% of (a) with aspect ratio > 10:1</u>	<u>% of (a) with aspect ratio > 15:1</u>	<u>% of (a) with aspect ratio > 20:1</u>
crocidolite South Africa	48	99	95	89
amosite South Africa	73	98	84	75
chrysotile Quebec	38	100	98	96
chrysotile (SEM) California	54	99	97	94
chrysotile (TEM) California	8	99	97	96

longer than 5 micrometers for four samples of commercial asbestos. These samples have been described by Campbell et al.⁶ The small widths and high aspect ratios are the hallmark of asbestos, even for amosite which has the widest widths and lowest tensile strength of the four major commercial asbestos varieties. Similar distributions are found for airborne fibers.²³

Tables II and III present the width and aspect ratio distributions for tremolite and actinolite samples of several different habits. Only data for particles longer than 5 micrometers with aspect ratios greater than or equal to 3:1 are included. Therefore, the data do not reflect the distribution within the

entire population but only for the particles that are elongated. (The data are limited to these dimensions because some of the data were collected only for these particles.)^{18,24}

Under the microscope, the two samples of actinolite-asbestos (samples 1 and 2) exhibit all the characteristics of the asbestiform habit and satisfy the commercial definition of asbestos. Sample 3 and sample 6 are both from India but are slightly different. Sample 3 is asbestos while sample 6 is a mixture of both asbestos and byssolite. The differences are most apparent in the percentage of particles with aspect ratios in excess of 20:1 (55 vs.25). The data for samples 4 and 5 come from Atkinson et al.¹⁸ The tremolite is associated with

vermiculite at both locations. At Libby, the tremolite is asbestiform (A.M. Langer, personal communication); at Enoree, South Carolina, the tremolite is described as a mixture of both asbestiform fibers and cleavage fragments.¹⁸ Samples 7, 8 and 9 are populations of cleavage fragments. The data for samples 8 and 9 were derived from particles collected on airfilters. These samples lack the characteristics of asbestos. The particles are much wider, shorter, and have smaller percentages with aspect ratios greater than 20:1 than asbestos.

CONCLUSIONS

In describing mineral samples for biological experiments, hand specimen descriptions, locations, chemical composition, microscopic properties and comprehensive dimensional data should be provided. If these data are available, the differences between cleavage fragments and asbestos fibers are obvious. Even fibrous nonasbestiform byssolite can be distinguished. It is essential if we are to understand what properties of minerals make them carcinogenic, fibrogenic or benign that comprehensive data be published for all minerals used in biological experimentation.

REFERENCES

1. Cooper, W: *Epidemiologic Studies of Mining Populations Exposed to Nonasbestiform Amphiboles*. Report to National Stone Association, 35 pgs. (1988).
2. Morgan, R.W., Foliart, D.E., Purcell, K.: *A Review of the Literature on the Carcinogenicity of Asbestiform and Non-asbestiform Actinolite, Tremolite and Anthophyllite*. Report to National Stone Association, 29 pgs. (1988).
3. OSHA, 29 CFR 1910.1001 and 29 CFR 1926.58 (1986).
4. *Glossary of Geology*, American Geological Institute, 801 pgs. G.M. McAfee and C. Wolf, Eds. (1974).
5. Dana, E., *A Textbook of Mineralogy*. W.E. Ford, Ed. John Wiley and Sons, N.Y. (1949).
6. Campbell, W.J., Huggins, C.W., Wylie, A.G.: *Chemical and Physical Characterization of Amosite, Chrysotile, Crocidolite and Non-fibrous Tremolite for Oral Ingestion Studies by the National Institute of Environmental Health Sciences. USBM R.I. #8452*, 66 pgs. (1980).
7. Sinclair, W.E.: *Asbestos: Its Origin, Production and Utilization*. Mining Publications, Ltd., Salisbury House, London, 879 pgs. (1959).
8. Wylie, A.G: *Optical Properties of the Fibrous Amphiboles. ANNAS 330:611-620* (1979).
9. Hutchison, J.L., Irusteta, M.C., Whittaker, E.J.W.: *High Resolution Electron Microscopy and Diffraction Studies of Fibrous Amphiboles. Acta Cryst. 31:794-801* (1975).
10. Dorling, M. and Zussman, J: *Characteristics of Asbestiform and Nonasbestiform Calcic Amphiboles. Lithos 20:469-489* (1987).
11. Deer, W.A., Howie, R.A., Zussman, J.: *Rock-forming Minerals 2:356 pgs.* (1962).

Table II
Tremolite and Actinolite—Width Distribution—
Particles with AR > 3:1

	(a)	(b)	(c)
	% longer than 5µm	% of (a) with width ≤ 1.0µm	% of (a) with width ≤ 0.5µm
1. actinolite-asbestos mountain leather locality unknown	12	98	90
2. actinolite-asbestos South Africa	10	96	70
3. tremolite-asbestos India(24)	No data available		
4. tremolite-asbestos(18) Libby, Montana	43	87	54
5. tremolite (variety?)(18) Enoree, South Carolina	22	81	48
6. tremolite, byssolite & asbestos India	8	61	34
7. tremolite New York	20	9	0
8. actinolite(airborne) Virginia(21)	29	11	<1
9. grunerite + actinolite (airborne) Minnesota(21)	2	<1	0

Table III
Tremolite and Actinolite—Aspect Ratio Distribution—Particles AR > 3:1, L > 5 μ m

	aspect ratio <u>\geq 10:1 (%)</u>	aspect ratio <u>\geq 15:1 (%)</u>	aspect ratio <u>\geq 20:1 (%)</u>
1. actinolite-asbestos mountain leather locality unknown	92	80	63
2. actinolite-asbestos South Africa	86	70	52
3. tremolite-asbestos India(24)	80	-	55
4. tremolite-asbestos Libby, Montana(18)	88	70	52
5. tremolite (variety)(18) Enoree, South Carolina	74	57	43
6. tremolite, byssolite & asbestos India	57	31	25
7. tremolite New York	8	4	4
8. actinolite (airborne) Virginia(21)	11	3	2
9. grunerite and actinolite Minnesota (airborne)(21)	1	0	0

12. Heinrich, E.W.: *Microscopic Identification of Minerals*: 347. McGraw Hill Book Company, New York, N.Y. (1965).
13. Zoltai, T.: The Importance of the Surface Structure and the Diameter Dependence of the Strength of Asbestos, Wisker and Glass Fibers, 30 pgs. (unpublished manuscript).
14. Harlow, G.E., Kimball, M.R., Dowty, E., Langer, A.M.: Observations on Amosite/Grunerite Dusts, pp. 1147-1157 *Appl. Miner.*, W.C. Park, D.M. Hausen and R.D. Hagni, Eds., AIME (1985).
15. Langer, A.M., Nolan, R.P.: Physicochemical Properties of Minerals Relevant to Biological Activities: State of the Art. *In Vitro Effects of Mineral Dusts*. E.G. Beck and J. Bignon, Eds., NATO ASI Series G3:9-24 (1985).
16. Shedd, K.B.: Fiber Dimensions of Crocidolites from Western Australia, Bolivia, and the Cape and Transvaal Provinces of South Africa. *USBM R.I. #8998*, 33 pgs. (1985).
17. Siegrist, H.G., Wylie, A.G.: Characterizing and Discriminating the Shape of Asbestos Particles. *Envir. Res.* 23:348-36 (1980).
18. Atkinson, G.R. et al.: Collection, Analysis and Characterization of Vermiculite Samples for Fiber Content and Asbestos Contamination. *Report to EPA Contract No. 68-01-5915* (1982).
19. Pooley, F.D., Clark, N.: A Comparison of Fibre Dimensions in Chrysotile, Crocidolite and Amosite Particles from Sampling of Airborne Dust and from Post Mortem Lung Tissue Specimens. *Biological Effects of Mineral Fibers I*: J. C. Wagner, Ed., IARC Scientific Publications 30:79-36 (1980).
20. Gibbs, G.W., Hwang, C.Y.: Dimensions of Airborne Asbestos Fibers. *Biological Effects of Mineral Fibers*, I. J.C. Wagner, Ed., IARC Scientific Publication 30:79-86, Lyon, France (1980).
21. Wylie, A.G., Virta, R.L., Russek, E.: Characterizing and Discriminating Airborne Amphibole Cleavage Fragments and Asbestos Fibers: Implications for the NIOSH Method. *Amer. Ind. Hyg. Assoc. Jour.* 46:197-201 (1985).
22. Wylie, A.G., Schweitzer, P.: The Effects of Sample Preparation and Measuring Techniques on the Shape and Shape Characterization of Mineral Particles: The Case of Wollastonite. *Envir. Res.* 27:53-73 (1982).
23. Wylie, A.G.: The Relationship Between the Growth Habit of Asbestos and the Dimensions of Asbestos Fibers. Society of Mining Engineers, *Preprint 8885:1-7* (1988).
24. Campbell, W.J., Steel, E.B., Virta, R.L., Eisner, M.H.: Relationship of Mineral Habit to Size Characteristics for Tremolite Cleavage Fragments and Fibers. *USBM R.I. 8367:18* (1979).

A NEW FIBROGENIC DUST SAMPLING METHOD FOR EPIDEMIOLOGY OF PNEUMOCONIOSIS

Y. HAMMAD • M. Ghiasseddin • H. Abdel-Kader

Tulane School of Medicine, Pulmonary Diseases Section, New Orleans, LA, USA

ABSTRACT

Current sampling instruments of respirable dust (RD) may over estimate the inhaled does by up to 400% depending on the size distribution of airborne dust. This limitation and the practice of assigning a single value for RD to all jobs regardless of the level of activity are incompatible with the advances in occupational epidemiology. A new dust sampler designed to estimate pulmonary deposition (PD) was developed to alleviate these limitations. The device consists of a 10 mm cyclone followed by a single-nozzle one-stage impactor. The dust fraction of interest is collected by impaction on a 10 mm diameter microscope cover slip. Estimation of PD is obtained by selecting the appropriate air flow rate and diameter of impactor so that the combined performance will simulate the bell shaped curves of PD at various respiratory frequencies and tidal volumes. This configuration was selected, rather than two impactors in series, to obtain better matching of PD (impactors have sharp cut-off curves). A cyclone can also collect large amounts of dust without overloading. Performance of the sampler was evaluated using monodispersed aerosols 1.1, 2.7, 4.7, 9.8 μm and geometric standard deviations < 1.2. The results indicate that PD is estimated very closely by the new sampler.

No Paper provided.

SYSTEM FOR PROTECTION AGAINST EXPOSURE TO ASBESTOS IN A FACTORY FOR DE-INSULATION OF RAILWAY CARS

B. SPERDUTO* • E. Graziano • N. Castellino*

*Institute of Occupational Health, Catholic University, Rome, Italy

INTRODUCTION

The Manufacturing of asbestos or the handling of products containing asbestos, provoke contamination of environments both in and out of work areas. The significant efforts made in the last few years, have shown that it is possible to control the work exposure risk within maximum safety limits. In fact, both the use of good procedure regulations and suitable personal protection means, together with constant and detailed instruction of personnel, can reduce professional exposure to levels of only a few fibers for liter of air.

On the contrary, it is not easy to prevent the dispersion of the fibers outside the work sites due to the large quantity of asbestos that moves around the continuous traffic of personnel in some way contaminated. Currently available information does not allow us to establish a threshold limit where the risk of cancer is null; in fact, the W.H.O. and other research agencies' projections require fiber dispersion to be practically null in external environments.

RESEARCH OBJECTIVES

Our research began by noting that currently existing recommendations and regulations regarding good procedures are not able to assure adequate environmental protection. In our opinion, one of the main causes of environmental contamination is, paradoxically, attributed to the workers means of protection. In fact, in order to achieve maximum safeguarding of workers, we are forced to constantly use personal means of protection, from the semi-protective mask to the positive pressure helmet. This creates the need for frequent breaks in decontaminated and clean areas, where the concentration of fibers is practically the same as the outside environment.

In order to obtain these conditions, the workers must pass through various areas where they remove their overalls, shoes and protective covering; in order to ascertain complete and safe decontamination, it is often compulsory to complete the latter under a shower of water (erf. Circular n. 45, Ministry of Health, Italy). It has been proven that simple, air spraying showers do not assure good decontamination of workers, thus the water shower appears to be indispensable if a perfectly clean rest area is desired. However, it is difficult to require the workers to take several showers, and they most probably will be tempted to pass quickly through, thwarting the efforts made to keep the rest area clean.

MATERIALS AND METHODS

In order to solve this problem, we thought of creating waterproof overalls that are attached to a sack-like helmet, which in turn is fed by a pump equipped with an absolute filter. The overalls are made of a light-weight polyester fabric (Figure 1) lined with a water vapor, permeable PTFE film. They weigh less than 500 grams. The overalls have a double zipper which closes in the front to assure that they are waterproof (Figure 2). There is also a long, semi-stiff collar (Figure 3) over which the neckline of the helmet is tightened (Figure 4). The inside of the helmet is equipped with an overturned "U" shaped diffusor that prevents the pump's air streams from fogging up the visor and from directly striking the workers face and head. Once the helmet is placed on the head and properly fitted and tightened around the overalls, the air penetrates the overalls slightly inflating them and finally exiting from the wrists and ankles (Figure 5), assuring transpiration from the workers body.

We tested this simple and easy to use personal protection system in a railway car de-insulation industry.

Upon exiting the work area, the workers pass through a multiphase decontamination system.

1. A water filled tank, approximately 20 cm in height, is used for the first washing of the rubber boots;
2. A first stall where a strong blast of air removes the larger fibers;
3. A second stall where a water shower thoroughly cleans the overalls and helmet, removing even the smallest of fibers (Figure 6);
4. A third stall where a stream of air dries the overalls and helmet;
5. By passing through a second water filled tank for an additional boot washing and two air locks, the workers have access to an area where they can remove their overalls, helmet and boots and then move on to the rest area dressed in the cotton clothing that they wear under the overalls.

The first tests we carried out show that with adequate worker training and careful study of work-break cycles, it is possible to limit the environmental concentration of the rest area, where some 50 people pass through, to 1-5 fibers/liter of air. The use of this decontamination system allowed us to reduce the environmental concentration of asbestos fibers. In fact, it was possible to soak the material to be de-insulated in a diluted solution of a tensio-active substance, thus reducing

environmental pollution from approximately 200 ff/ml to approximately 5 ff/ml during the highest pollution production phase. With the previous air-spray decontamination system, it was not possible to wet the asbestos. We are currently

researching ways to optimize this study, reducing the metabolic charge as much as possible, in order to limit perspiration, thus improving the workers comfort and reducing the frequency of breaks.





Figure 2.

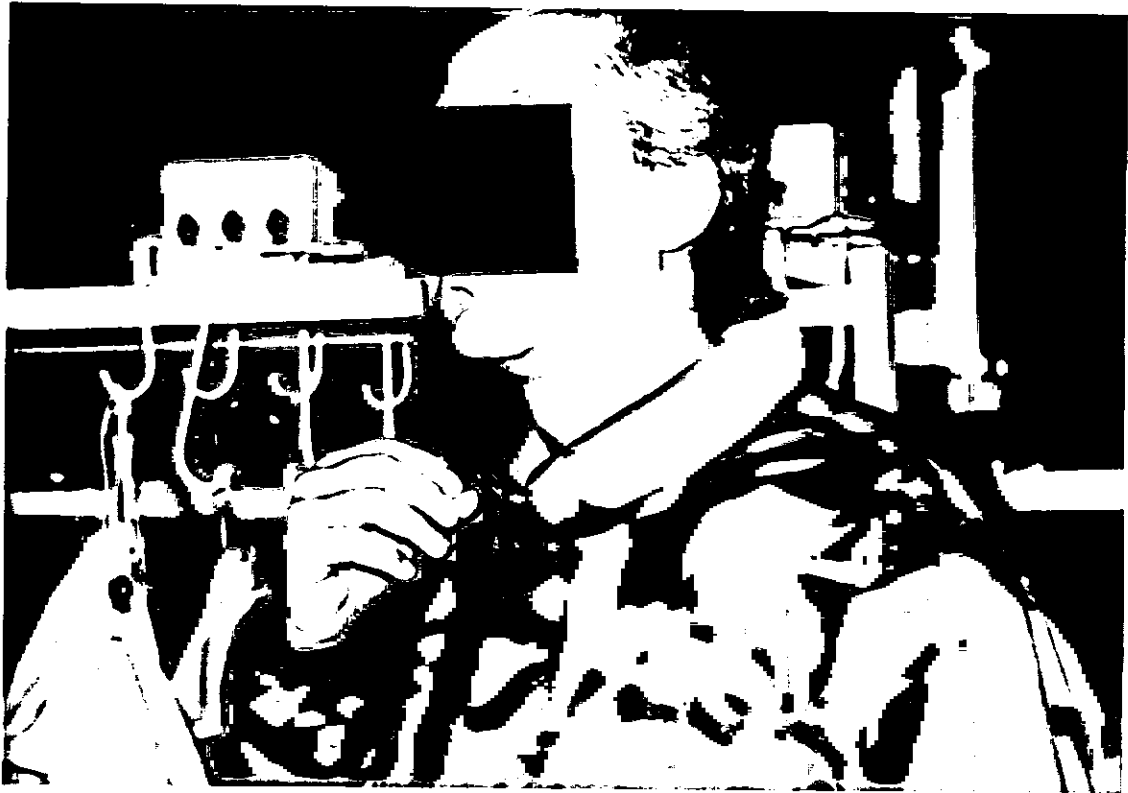

Figure 3.



Figure 4.



Figure 5.



Figure 6.

ENVIRONMENTAL PULMONARY MINERAL BURDEN CORRELATED WITH SMOKING, PULMONARY EMPHYSEMA AND LUNG CANCER

O. TAIKINA-AHO • S. Anttila • P. Pääkkö • S.J. Sivonen • P.L. Kalliomäki

Institute of Electron Optics and Department of Pathology, University of Oulu, Oulu, Finland, and Institute of Occupational Health, Helsinki, Finland

INTRODUCTION

In order to be able to identify a significant lung particle burden exceeding the background, it is necessary to know the basic pulmonary level of inhaled particles in a population. The amount of asbestos fibers in lung tissue which could originate from environmental sources would be an especially important piece of information. Numbers of asbestos fibers reported in the lung tissue of occupationally non-exposed people in the literature have varied from less than half a million to several millions per gramme of dry lung tissue.¹⁻³ Some of the differences may be due to inter-laboratory variation in fiber determinations, which has been reported to be vast.⁴

Environmental exposure to minerals varies at least due to local climatic conditions, the earth's crust and environmental pollution. The worst personal source of pollution is smoking. Smoking in itself, and diseases related to it, including chronic obstructive lung disease, pre-cancerous bronchial epithelial changes and cancer, may alter the deposition and retention of inhaled particles. Pulmonary emphysema is a morphological counterpart of chronic obstructive lung disease, and its severity also serves as an objective indicator for the duration of smoking in the course of the subjects life. The present paper describes pulmonary mineral content in a series of occupationally non-exposed subjects from Northern Finland and compares it with smoking history, the grade of pulmonary emphysema and the presence of lung cancer.

MATERIAL

20 cases were selected from an initial series of 42 male subjects who had died of non-malignant diseases and been autopsied and 53 male patients operated on for lung cancer. Smoking habits, measured in smoking time, pack years and time since stopping smoking, and also occupational history, were determined from the patient or from the next of kin by means of a questionnaire and/or personal interview. The effects of smoking, pulmonary emphysema and lung cancer on the pulmonary mineral content were studied in 13 pairs matched in terms of given background characteristics (Tables I-III).

METHODS

The lungs and lung lobes obtained from the autopsies and surgical operations were radiographed during continuous air inflation⁵ and the severity of emphysema was graded into normal, mild, moderate and severe from these radiographs

on the grounds of peripheral vascular changes, tissue defect translucencies and changes in the shape of the lung or lobe.⁶ The lungs were fixed transbronchially with hyperosmolar formalin. The grade of emphysema was also estimated from gross specimens and histological sections and these data were used if grading from the radiographs did not produce an unambiguous result. The histological type of cancer was determined according to the WHO classification of tumours.

A 0.5-1 g peripheral sample of fresh lung tissue containing no pleural surface or cancer tissue was taken from the (apico) posterior segment of the upper lobe and the apical segment or basal segments of the lower lobe after radiographing. The samples were ashed in aluminium cups in a low temperature ashing with an oxygen plasma, after which the ash was dissolved in 1 M nitric acid to remove excess salt and then in absolute ethanol and distilled water. The residue was sonicated and various dilutions filtered onto a Nuclepore filter of pore size 0.1 μm . The filter, coated with carbon, was transferred onto a gold grid and dissolved slowly in chloroform vapour. The grid was coated again with carbon to minimize charging.

Electron microscopy was performed using a JEOL 100CX scanning transmission electron microscope (STEM) and PGT SYSTEM III energy dispersive spectrometry (EDS). At least a hundred particles ($>0.1 \mu\text{m}$) per specimen were identified using EDS analysis and electron diffraction. Two dimensions on each particle were measured on the STEM image, the thickness being assumed to be equal to the width for all minerals other than phyllosilicates ($0.2 \times$ width). Approximate volumes were calculated for the minerals, after which their masses could be determined from their known densities. To determine the number of fibers, 100 fibrous particles having the length to diameter ratio $\geq 3:1$ were searched and identified. Statistical comparisons were performed using paired t-tests, in which p values less than 0.05 were considered significant.

RESULTS

The pulmonary particle burden, measured as total mass, volume and surface area, showed very narrow variation depending on smoking, pulmonary emphysema or lung cancer, whereas the number of particles and the mean particle size showed some dependence on these factors. The mean total number, volume, surface area and mass of mineral particles in the material (\pm SD) were $155 \pm 194 \times 10^6$, $0.15 \pm 0.16 \text{ mm}^3$, $655 \pm 670 \text{ mm}^2$ and $0.41 \pm 0.43 \text{ mg}$ per

Table I
 Characteristics of the Case-Control Pairs Chosen for
 Studying the Effect of Smoking on the Pulmonary Mineral Burden

	Age	Smoking	Smoking time	Grade of emphysema	Occupation	Lung cancer	Site of sample*
1.	75	Non-smoker	0	No	Farmer	No	BLL
	71	Smoker	25	Mild	Unknown	No	AUL
2.	79	Non-smoker	0	Mild	Unknown	No	BLL
	75	Smoker	44	No	Roadman	No	BLL
3.	73	Non-smoker	0	Mild	Car driver	No	AUL
	61	Smoker	46	Mild	Road scraper driver	No	AUL
4.	77	Non-smoker	0	No	Unknown	No	BLL
	72	Smoker	25	No	Salesman	No	BLL

* AUL= apical upper lobe, ALL= apical lower lobe, BLL= basal lower lobe

Table II
 Characteristics of the Case-Control Pairs Chosen for Studying
 the Effect of Pulmonary Emphysema on the Pulmonary Mineral Burden

	Age	Smoking	Smoking time	Grade of emphysema	Occupation	Lung cancer	Site of sample*
1.	72	Smoker	25	No	Salesman	No	BLL
	71	?	?	Severe	Unknown	No	BLL
2.	71	Smoker	25	Mild	Unknown	No	AUL
	60	Ex-smoker	25	Moderate	Clerk	No	BLL
3.	75	Non-smoker	0	No	Farmer	No	BLL
	68	Ex-smoker	25	Moderate	Farmer	No	AUL
4.	77	Non-smoker	0	No	Unknown	No	BLL
	73	?	?	Severe	Roadman	No	AUL
5.	75	Smoker	44	No	Roadman	No	BLL
	69	Smoker	50	Moderate	Caretaker	No	AUL

* AUL= apical upper lobe, ALL= Apical lower lobe, BLL= Basal lower lobe

Table III
 Characteristics of the Case-Control Pairs Chosen for Studying
 the Effect of Lung Cancer on the Pulmonary Mineral Burden

	Age	Smoking	Smoking time	Grade of emphysema	Occupation	Lung cancer	Site of sample*
1.	68	Ex-smoker	25	Moderate	Farmer	No	AUL
	65	Ex-smoker	35	Moderate	Farmer	Yes	BLL
2.	71	Smoker	57	Moderate	Mason	No	ALL
	60	Smoker	40	Moderate	Sawyer	Yes	AUL
3.	71	Smoker	25	Mild	Unknown	No	AUL
	63	Ex-smoker	40	Mild	Surveyor technician	Yes	ALL
4.	74	Smoker	50	Moderate	Caretaker	No	AUL
	73	Ex-smoker	25	Moderate	Roadwork foreman	Yes	ALL

* AUL= apical upper lobe, ALL= apical lower lobe, BLL= basal lower lobe

gramme of dry lung tissue respectively. In individual cases the number of particles varied from 10×10^6 to 670×10^6 , and the number of fibers from less than a hundred thousand to 10×10^6 per gramme of dry weight. The asbestos fibers were mostly anthophyllite and crocidolite, but not many amosite and chrysotile were found.

Smoking

The number of particles, including every particle type except fibers, aluminium, plagioclase and talc, was greater in the lung tissue of the smokers than in their matched non-smoking counterparts. Kaolinite particles were especially numerous in the lungs of the smokers as compared with the non-smokers. The differences in the number and type of particles between the non-smokers and smokers were not statistically significant, however. The mean particle size (mean volume of single particles) was larger in the non-smokers than in the smokers ($p=0.065$) (Table IV).

Pulmonary Emphysema

The total number of particles in patients with moderate or severe pulmonary emphysema was lower than in their matched pairs with mild or no emphysema. Plagioclase was the only particle type which was more numerous in the emphysematous lungs. The mean size of single particles was significantly larger in the patients with moderate or severe emphysema as compared with controls who had mild or no emphysema ($p<0.05$) (Table V).

Lung Cancer

All the cancers included in the material were histologically of the squamous cell type. The total number of particles did

not differ significantly between the patients with lung cancer and their matched controls, but the numbers of fibers, plagioclase, and particles containing aluminium, iron or titanium only, were higher in the lung cancer patients, the difference in the number of fibers being statistically significant ($p<0.05$) (Table VI).

DISCUSSION

The pulmonary mineral particle burden was measured here in terms of total number, mass, volume and surface area. The number of particles varied from case to case and due to smoking and pulmonary emphysema more than the other parameters did. The total number of particles found in the lung tissue of the patients without known occupational exposure to minerals is in a fairly good agreement with the findings of Churg and Wiggs.⁷ In the present study smokers' lung tissue contained more particles than that of the non-smokers, although the difference was not statistically significant. The total volume of particles did not differ between the smokers and matched non-smokers, but the average volume of the individual particles was smaller in smokers, the difference approaching statistical significance. Churg and Wiggs⁷ found more particles in the lungs of heavy smokers than in those of light smokers. It is not known whether the numerous small particles such as kaolinite in smokers' lung tissue originate from the tobacco smoke or whether their additional presence is due to a deterioration in mucociliary clearance in smokers.

The effect of pulmonary emphysema on the total number of particles and the mean volume of single particles seemed to be the opposite of that of smoking. The small number of particles in the emphysematous lungs may be attributable firstly to tissue destruction, and secondly by a reduction in the inhalation of particles from tobacco smoke, since many people

with marked emphysema stop or cut down their smoking because of dyspnoea.

The lung cancer patients did not differ significantly from their matched controls in terms of pulmonary particle burden. Churg and Wiggs² found a greater number of particles in lung cancer patients than in controls without cancer, but this could not be found here. On the other hand, the number of fibers was significantly higher in the lungs of the present lung cancer patients than in those of the controls, even though none of them had any known occupational exposure to asbestos.

The same observation is recorded by Churg and Wiggs,² but the number of fibers they found in both the lung cancer and control patients was about ten times higher than we could detect. Similarly, ten to fifteen times higher pulmonary concentrations of fibers are reported in lung cancer patients in another study from Great Britain⁸ than we found in our patients. The difference may be due to the slightly different methods used, but it is also possible that the finding is real and reflects the degree of local environmental outdoor pollution or an unrecognized presence of asbestos materials in buildings.

Table IV
Mean Number and Type of Particles in Lung Tissue from Non-Smokers and Smokers

	Non-smoker	-	Smoker	t	p
	(4 pairs)				
Total number ($\times 10^6$ /g dry w.)	106	-	214	- 0.6	NS
Total volume (mm^3 /g dry w.)	0.2	-	0.2	- 0.2	NS
Total surface (mm^2 /g dry w.)	736	-	798	- 0.1	NS
Total mass (mg/g dry w.)	0.4	-	0.5	- 0.2	NS
Mean particle volume (μm^3)	1.5	-	0.8	2.5	<0.07
Numbers of particles ($\times 10^6$ /g dry w.):					
Fibers	3.2	-	1.2	0.6	NS
Al	0.9	-	0.5	0.5	NS
Fe	8.1	-	14.8	- 0.4	NS
Kaolinite	7.6	-	29.9	- 0.8	NS
K-feldspar	18.2	-	27.8	- 0.5	NS
Mica	23.4	-	60.5	- 0.7	NS
Plagioclase	15.4	-	9.6	1.0	NS
Quartz	14.8	-	27.8	- 0.5	NS
Talc	2.1	-	2.0	0.1	NS
Ti	5.5	-	10.0	- 0.4	NS
Others	10.5	-	29.0	- 0.8	NS

Table V
 Mean Number and Type of Particles in Lung Tissue from
 Patients with and without Pulmonary Emphysema

	No emphysema - Emphysema (5 pairs)		t	p
Total number ($\times 10^6$ /g dry w.)	194	- 50	1.1	NS
Total volume (mm^3 /g dry w.)	0.2	- 0.2	0.1	NS
Total surface (mm^2 /g dry w.)	718	- 453	0.5	NS
Total mass (mg/g dry w.)	0.5	- 0.4	0.1	NS
Mean particle volume (um^3)	1.0	- 2.8	- 2.8	<0.05
Numbers of particles ($\times 10^6$ /g dry w.):				
Fibers	0.9	- 0.3	0.9	NS
Al	0.9	- 1.0	- 0.1	NS
Fe	15.4	- 0.1	1.5	NS
Kaolinite	26.2	- 3.6	1.1	NS
K-feldspar	25.7	- 10.5	1.0	NS
Mica	50.4	- 6.0	1.1	NS
Plagioclase	11.1	- 13.4	- 0.6	NS
Quartz	27.3	- 5.4	1.3	NS
Talc	2.2	- 0.6	1.5	NS
Ti	11.5	- 2.0	1.2	NS
Others	22.8	- 7.5	0.8	NS

Table VI
Mean Number and Type of Particles in Lung Tissue from
Patients with and without Lung Cancer

	No cancer - Lung cancer (4 pairs)		t	p
Total number ($\times 10^6$ /g dry w.)	218	- 164	0.3	NS
Total volume (mm^3 /g dry w.)	0.3	- 0.1	1.5	NS
Total surface (mm^2 /g dry w.)	1098	- 541	0.8	NS
Total mass (mg/g dry w.)	0.9	- 0.3	1.4	NS
Mean particle volume (μm^3)	2.7	- 0.9	2.0	NS
Numbers of particles ($\times 10^6$ /g dry w.):				
Fibers	0.2	- 1.2	- 2.9	<0.05
Al	0.6	- 5.3	- 0.8	NS
Fe	13.2	- 16.2	- 0.1	NS
Kaolinite	29.5	- 9.5	0.7	NS
K-feldspar	29.3	- 23.6	0.3	NS
Mica	58.9	- 13.7	0.9	NS
Plagioclase	12.7	- 26.4	- 1.4	NS
Quartz	30.0	- 16.6	0.5	NS
Talc	0.2	- 0.0	1.0	NS
Ti	11.4	- 41.2	- 0.8	NS
Others	32.1	- 11.9	0.9	NS

REFERENCES

- Churg, A., Warnock, M.L.: Asbestos Fibers in the General Population. *Am. Rev. Resp. Dis.* 122:669-679 (1980).
- Churg, A., Wiggs, B.: Mineral Particles, Mineral Fibers and Lung Cancer. *Environ. Res.* 37:364-372 (1985).
- Warnock, M.L., Wolery, G.: Asbestos Bodies or Fibers and the Diagnosis of Asbestosis. *Environ. Res.* 44:29-44 (1987).
- Gylseth, B., Churg, A., Davis, J.M.G. et al.: Analysis of asbestos fibers and asbestos bodies in tissue samples from human lung. *Scand. J. Work. Environ. Health* 11:107-110 (1985).
- Sutinen, S., Lohela, P., Pääkkö, P., Lahti, R.: Accuracy of Post-mortem Radiography of Excised Air-inflated Human Lungs in Assessment of Pulmonary Emphysema. *Thorax* 37:906-912 (1982).
- Sutinen, S., Pääkkö, P., Lahti, R.: Postmortem Inflation, Radiography, and Fixation of Human Lungs: A Method for Radiological and Pathological Correlations and Morphometric Studies. *Scand. J. Respir. Dis.* 60:29-35 (1979).
- Churg, A., Wiggs, B.: Types, Numbers, Sizes, and Distribution of Mineral Particles in the Lungs of Urban Male Cigarette Smokers. *Environ. Res.* 42:121-129 (1987).
- Wagner, J.C., Newhouse, M.L., Corrin, B., Rossiter, C.E.R., Griffiths, D.M.: Correlation between fibre content of the lung and disease in east London asbestos factory workers. *Br. J. Ind. Med.* 45:305-308 (1988).

ELEMENT ANALYSES IN HUMAN LUNG TISSUE CORRELATED WITH SMOKING, EMPHYSEMA AND LUNG CANCER

P.L. KALLIOMÄKI* • P. Pääkkö† • P. Kokkonen‡ • S. Anttila* • K. Kalliomäki§

*Institute of Occupational Health, Helsinki, Finland

†Department of Pathology

‡Department of Chemistry

§Electrical Measuring Technique, University of Oulu, Oulu, Finland

INTRODUCTION

The results of recent investigations have shown that several heavy metals accumulate in the lung tissue after inhalation of relatively insoluble compounds.³ The quantitative detection of the heavy metals in samples of pulmonary tissue hence permits the amount of postexposure to be estimated.⁵ Recently, there are many possibilities for occupational and environmental exposures to several trace elements and heavy metals. In addition to organic compounds tobacco contains metals such as As, Cd, Cr and Ni.² Chromium and cadmium are toxic and carcinogenic elements.

Fragmental knowledge has been published on the tissue levels of major and minor trace elements in the human lungs in relation, e.g., to the exposure to cigarette smoke and pulmonary tissue reactions.⁷ Modern analytical instrumentation reveals new possibilities for detecting a number of elements in the same sample.

The aim of this study is to determine the concentrations of light elements derived mainly from minerals, heavy metals and essential trace elements in human lung tissue. The elemental concentrations found in lung tissue are related to smoking, emphysema and lung cancer.

MATERIAL

The lung specimens were collected from subjects without any malignant disease and from the lung cancer patients. The

group without malignancies consisted of 41 lungs (alternatively the right or the left lung) from consecutive autopsies of male subjects with or without emphysema (Table I). Because emphysema is an indicator of smoking, the subjects without lung cancer were selected to include cases with different grades of emphysema (Table II). Smoking habits and occupational history were ascertained from the next of kin. The lungs or lung lobes have been obtained from 52 male patients operated for lung cancer (Table I). Smoking habits and occupational history have been acquired by personal interview.

METHODS

The lungs and lobes of lungs were radiographed during continuous air-inflation, and the severity of emphysema was graded from the radiographs into normal lung and mild, moderate and severe emphysema.⁶ In addition, the grade of emphysema⁴ and the histological types of cancer were determined from histological sections.¹

A piece of fresh lung tissue was taken after radiographing from the (apico) posterior and anterior segment of the upper lobe and from the superior (apical) segment and basal segment of the lower lobe.^{1,4} The sample, measuring 0.5–2 g, contained no pleural surface or cancer tissue. Equal portions of samples representing left and right lungs were analyzed of the non-malignant and cancer material. The fresh sample was weighted, dried for three hours in vacuum, and ashed in glass cups with a blank and NBS Bovine Liver (SMR 1577) for

Table I
Age, Smoking Habits and Grade of Emphysema of the Subjects without Cancer (Autopsy Lungs) and of the Lung Cancer Patients

	Autopsy lungs (N = 41)	Lung cancer patients (N = 52)
Age, years	68 ± 9	62 ± 10
Smoking time, years	36 ± 15	39 ± 11
Stopped, years ago	7 ± 10	5 ± 8
Grade of emphysema	2.5 ± 0.9	2.6 ± 0.8

Table II
Age and Smoking Habits of the Subjects without Cancer (a) and the Lung Cancer Patients (b) Grouped as a Function of Emphysema

a)	Autopsy lungs (N = 43)			
	Grade I (normal) (N = 4)	Grade II (mild) (N = 20)	Grade III (moderate) (N = 9)	Grade IV (severe) (N = 8)
Age, years	75 ± 2	64 ± 9	65 ± 8	75 ± 5
Smoking time, years	26 ± 9	32 ± 12	37 ± 13	49 ± 13
Stopped, years ago	6 ± 12	6 ± 11	6 ± 10	10 ± 5
Stopped	(N = 4)	(N = 16)	(N = 9)	(N = 6)
b)	Lung cancer patients (N = 52)			
	Grade I (normal) (N = 3)	Grade II (mild) (N = 18)	Grade III (moderate) (N = 20)	Grade IV (severe) (N = 6)
Age, years	53 ± 14	59 ± 13	65 ± 6	63 ± 7
Smoking time, years	38 ± 16	34 ± 12	44 ± 9	42 ± 8
Stopped, years ago	0	6 ± 9	4 ± 7	3 ± 3
Stopped	(N = 0)	(N = 10)	(N = 7)	(N = 4)

Table III
The Element Concentrations in Lung Tissue of the Subjects without Malignant Disease and in Surgical Specimens from Lung Cancer Patients

Element	µg/g dry weight				
	Autopsy lungs		Surgical specimens		P
	Mean	Geometric SD	Mean	Geometric SD	
Mg	380	2.0	430	1.8	0.007
Ca	630	1.7	740	1.6	
Ti	8.3	2.6	14	3.3	0.031
Cr	2.5	3.2	4.5	2.5	0.006
Fe	1100	1.6	980	2.5	
Cu	12	1.5	13	1.8	
Zn	47	1.5	50	1.2	
Cd	1.2	3.5	2.5	2.6	0.012

48–72 hours in a low temperature oxygen plasma asher (100–120°C).

Tissue residue was digested in a mixture of 3 ml concentrated nitric acid (supra pure grade) and 0.2 ml of perchloric acid at 150°C for 2 hours, after which the solution was allowed to stand over night and diluted in 3–6 ml of high quality water. The plasma emission (DCP-AES) spectrometer (Spectra-Span IIB) was used to determine trace elements (Ca, Mg, Cu, Zn, Fe) and heavy metal (Ti, Cr, Cd). The validity of the overall procedure and the effective control of contamination were

checked by analyzing the blank throughout the procedure in each test series and employing the NBS Bovine Liver (SMR 1577) standards.

RESULTS AND DISCUSSION

The concentrations of eight elements in lung tissue were analyzed (Table III). The mean and geometric standard deviations of most of the elements studied lie between those published in present papers.⁷

The concentrations of Mg, Ti, Cr and Cd were higher in the surgical specimens of lung cancer patients than in autopsy lung tissue of non-malignant subjects. Table IV reveals that the severity of emphysema is related to the increase of the concentrations of Ca, Cd and Cr. The moderate and severe emphysema is related to the decrease of the concentrations of Cu and Fe. In lung tissue of non-malignant autopsy lungs the effect of severity of emphysema was more prominent (Table IV).

The effect of cigarette smoke upon the elements in the lungs was estimated (Table V). A positive correlation, but not statistically significant, between the concentrations of Cr and Cd and smoking time was found in the non-malignant autopsy lungs of the current smokers. The surgical specimens revealed no significant trend in the concentrations of any element as a function of smoking time. The concentration of Cd was significantly decreased in lung tissue of ex-smokers in both groups (Table V). A relative correlation was observed between non-smoking years and the Cd lung content among ex-smokers. The biological half-time for Cd in human lung was estimated to be about 9 years.⁴ The concentration of Cr was slightly higher in the lung tissue of ex-smokers than in

that of current smokers.

REFERENCES

1. Anttila, S., Kokkonen, P., Pääkkö, P., Kerola, T., Rainio, P., Kalliomäki, P.-L., Sutinen, S.: *Extended Abstracts: Trace Elements in Human Health and Disease*. pp. 173-176 (2nd Nordic Symposium, Odense, Denmark, 17-21 August 1987).
2. *IARC Monographs on the Evaluation of the Carcinogenic Risk of Chemicals to Humans. Tobacco Smoking*. Vol. 38. International Agency for Research on Cancer, Lyon (1986).
3. Kollmeier, H., Leeman, J.W., Muller, K.M., Rothe, G., Wittig, P., Schejbal, V.B.: Increased Chromium and Nickel Content in Lung Tissue and Bronchial Carcinoma. *Am. J. Ind. Med.* 11:659-669 (1987).
4. Pääkkö, P., Anttila, S., Kokkonen, P., Kalliomäki, P.-L.: Cadmium in Lung Tissue as Marker for Smoking. *Lancet* 1:477 (1988).
5. Raithel, H.J., Schaller, K.H., Reith, A., Svenes, K.B., Valentin, H.: Investigations on the Quantitative Determination of Nickel and Chromium in Human Lung Tissue. *Int. Arch. Occup. Environ. Health* 60:55-66 (1988).
6. Sutinen, S., Pääkkö, P., Lobela, P., Lahti, R.: Pattern Recognition in Radiographs of Excised Air-Inflated Human Lungs in Emphysema Alone and with Other Common Lesions. *Eur. J. Resp. Dis.* 62:297-314 (1981).
7. Vanooteren, C., Cornelis, C., Sabbioni, E.: *Critical Evaluation of Normal Levels of Major and Trace Elements in Human Lung Tissue*. Commission of the European Communities, Luxemburg (1986).

Table IV
Effect of the Severity of Emphysema upon the Element Concentration in Non-Malignant Autopsy Lungs (a) and in the Lungs of Lung Cancer Patients (b)

Mean, µg/g dry weight							
a) Autopsy lungs (N = 41)							
	Grade I	Grade II	p	Grade III	Grade IV	p	Trend; T ¹⁾
Hg	250	400	0.007	390	390		N.S.
Ca	440	560		710	870		/ ; -2.7*
Ti	7.6	7.2		12	8.3		
Cr	1.6	1.3		3.4	7.1		/ ; -5.2*
Fe	830	1300	0.09*	1200	790		Λ ; N.S.
Cu	5.9	13	0.001*	13	9.3	0.1*	Λ ; N.S.
Zn	25	52	0.01*	50	42		/ ; -2.8*
Cd	0.3	1	0.16	1.7	1.8		/ ; -1.9*
b) Lung cancer patients (N = 51)							
	Grade I	Grade II	p	Grade III	Grade IV	p	Trend; T ¹⁾
Hg	390	430		430	450		N.S.
Ca	490	760		790	870		/ ; N.S.
Ti	4.0	26	0.04*	10	14		N.S.
Cr	2.7	5.4		4.4	3.4		N.S.
Fe	760	1000		1100	870		Λ ; N.S.
Cu	9.6	14	0.07*	14	15		N.S.
Zn	48	49		50	56		N.S.
Cd	-	2.1		2.0	3.7		/ ; N.S.

1) Student's t-test value

Table V
Effect of Smoking Habits upon the Element Concentrations
in Lung Tissue of the Subjects without Cancer and of Lung Cancer Patients

Element	Mean, $\mu\text{g/g}$ dry weight					
	Autopsy lungs		p	Surgical specimens		p
	Smokers	Ex-smokers		Smokers	Ex-smokers	
Hg	390	340		420	450	
Ca	630	660		650	960	0.005
Ti	11	7		11	18	
Cr	1.5	3.5	0.03	4.3	5.4	
Fe	1320	930	0.05	980	930	
Cu	13	10	0.03	13	13	
Zn	48	41		48	52	
Cd	2.6	0.8	0.001	3.5	1.6	0.042

LUNG FIBROSIS ASSOCIATED WITH RARE EARTH EXPOSURE

J.R. RÜETTNER • M.A. Spycher • P. Vogt

Zürich Pneumoconiosis Research Group, Institute of Pathology, University Hospital Zürich, Switzerland

Diffuse interstitial lung fibrosis (DILF) with the most prominent clinical sign of progressive restriction of respiratory function may have a variety of causes. The spectrum of disorders in this category is very large and still growing.¹ Besides cases with known etiology — viral, bacterial, environmental etc. — the group of so called cryptogenic or idiopathic interstitial pulmonary fibrosis deserves special attention. Among these primarily obscure cases those originating from unrecognized inhalation of organic or inorganic particles may be hidden. In recent years the application of sophisticated methods for the search of inorganic noxious particles often has been most successful in finding the true cause of pulmonary fibrosis, for instance in workers exposed to hard metals² or in asbestosis mimicking interstitial pulmonary fibrosis induced by mica.³

Presently we wish to concentrate on diffuse interstitial lung fibrosis (DILF) observed in reprophotographers. Until 1960 in Switzerland in large printing laboratories carbon arc lamps have been used as powerful light sources for reproducing photographs. The carbon rods contain coal and a wick of rare earth metal compounds such as Lanthanum, Cerium, Praseodymium, Neodymium and also Thorium. The reprophotographers have been exposed to fumes occurring during burning of the carbon rods.

After years of exposure the workers developed a slowly progressive dyspnoea. Radiographs showed a diffuse interstitial pulmonary fibrosis. From the 9 patients reported only three were diagnosed during life by lung biopsy as suffering from rare earth exposure. The majority of the cases were diagnosed as "idiopathic" interstitial pulmonary fibrosis, since etiology and relation to occupational fume exposure were not recognized during life.

The average exposure time was about 31 years, the latency period (interval between onset of exposure to time of analysis) was on the average 43 years. Data on the concentration of fume and dust at the workplace are not available. The first cases were traced and shown to be related to reprophotographer occupation more than ten years after cessation of the use of carbon rod lamps. We analyzed our first case in 1972, the last of our series in 1987 (Table I). Because of that, for the recognition of the lung disorder as due to occupational injury the histopathological and mineralogical examination of the diseased lung tissue with a variety of modern methods and a careful occupational history is crucial.

The techniques applied were: histology, transmission elektronmicroscopy, energy dispersive X-ray analysis

(EDXA), selected area electron diffraction (SAED), and X-ray spectroscopy.^{4,5,6}

PATHOLOGY

Gross pathology in all autopsied cases of interstitial pulmonary fibrosis was similar and sometimes difficult to assess. Extensive severe bilateral involvement occurred in only one case. Focal irregular scarring resembling honeycombing was also observed. Emphysematous areas were seen in all cases.

Microscopically the prominent features were marked interstitial fibrosis with mild interstitial infiltration. Lobular and interlobular septa were fibrosed and occasionally showed proliferation of smooth muscle cells. Interstitial infiltrates of macrophages containing small non birefringent particles less than 10 micrometer were present and there was perivascular accumulation of small deposits of dust particles. Granulomas were absent. Some alveolar spaces contained groups of macrophages with dust inclusions. The type II pneumocytes were proliferating in some areas. There was focal honeycombing with septal retraction. The pulmonary vessels showed mild hypertensive changes with muscularization of arterioles.

ELECTRON MICROSCOPY

In alveolar macrophages as well as in extracellular interstitial spaces electron dense irregular deposits ranging from 0.1 to 10 micrometer were seen. They consisted of densely packed rodlike mineral particles 0.01 micrometers in diameter and 0.1 micrometer in length.

Energy dispersive X-ray analysis (EDXA) revealed elements of the lanthanides series. Lanthanum, Cerium were regularly found, less often Praseodymium and Neodymium were noted. Selected area electron diffraction (SAED) of the aggregates resulted in diffraction patterns characteristic of brockite and rhabdophane respectively according to the ASTM Standards. Brockite and rhabdophane are carbonates and phosphates of the lanthanides.⁷

X-ray spectroscopy (Debye-Scherrer) revealed Samarium, Holmium and Thorium in one case and Yttrium in another. The results are summarized in Table II.

DISCUSSION

Although Lanthanides are widely used in industry, (nowadays also in superconductivity material Bednorz & Müller Nobelprize 1987) little is known about their effects on human health. The first radiological report on the lung disease of

workers exposed to rare earth was published in 1955 by Scheppers.⁸ As in our material most of the diseased persons were engaged in reprophotographic work, and worked for years with carbon arc lamps producing fumes containing Lanthanides and root.⁹ Unfortunately no data are available concerning concentration and particle size of the original fumes. Retrospectively the patients or their relatives described the working place as dusty and covered with a fine white powder.

Clinical symptoms occurred in most cases many years after cessation of exposure. At the time of the clinical diagnosis of a restrictive lung disorder with the radiologic feature of pulmonary fibrosis neither the patients nor the physicians were aware of a rare earth exposure.

The slowly progressive restrictive lung disease and its unknown origin led to the diagnosis of "idiopathic" pulmonary fibrosis.

Pathological findings were not specific. The search for exogenous particles proved to be successful and disclosed fume particles consisting of rare earth compounds. Microscopically it was difficult to visualize them. Electron microscopy, however, led to the discovery of particles of ultramicroscopic size in places where their presence was unsuspected. The size of the particles ranged from 0.1 to 10 micrometer. They were aggregates of crystals measuring approximately 0.01 micrometer in diameter and 0.1 micrometer in length.

Pathogenetically rare earth pneumoconiosis resembles the

pulmonary fibrosis of hard metal workers which is similarly caused by very small dust particles. Rare earth interstitial lung fibrosis is another example of a lung disorder formerly called cryptogenic and ultimately elucidated by mineralogic analysis of the diseased lung tissue. The correlation with a careful occupational history is also a prerequisite for precise diagnosis.

REFERENCES

1. Colby, T.V., Carrington, C.B.: Infiltrative Lung Disease in *Pathology of the Lung*, Ed. Thurbeck, W.M., New York, 1988, 424-517.
2. Rüttner, J.R., Spycher, M.A., Stolk, I.: Inorganic particulates in pneumoconiotic lungs of hard metal grinders. *Brit. J. Ind. Med.* 44:657-660 (1987).
3. Rüttner, J.R., Spycher, M.A., Sticher, H.: Diffuse "Asbestosis-like" interstitial fibrosis of the lung. *Path. & Microbiol.* 31:250-257 (1972).
4. Abraham, J.L.: Analysis of particulates in tissue. in *Environmental Pathology*, Ed. Hill, R.B., Terzian J.A., New York 1982, 229-241.
5. Rüttner, J.R., Spycher, M.A., Sticher, H.: The detection of etiologic agents in interstitial pulmonary fibrosis. *Hum. Pathol.* 4: 497-512 (1974).
6. Ehrenreich, T., Mackler, A.D., Langer, A.M.: Identification and characterization of pulmonary dust burden in pneumoconiosis. *Ann. Clin. Lab. Sci.* 3:118-135 (1973).
7. Sticher, H., Spycher, M.A., Rüttner, J.R.: Crystallization in vivo of Rhabdophane in human lungs. *Nature* 241:49 (1973).
8. Scheppers, G.W.H.: The biological action of rare earths. *Arch. Industr. Health* 12:301-316 (1955).
9. Vogt, P., Spycher, M.A., Rüttner J.R.: Pneumokoniose durch "Seltene Erden" (Cer-Pneumokoniose). *Schweiz. med. Wschr.* 116: 1303-1308 (1986).
10. Menz, E., Kaufmann, E.: Lungenveränderungen durch "Seltene Erden". *Z. Unfallmed. Berufskr.* 65: 62-73 (1972).
11. Kappenberger, L., Bühlmann, A.A.: Lungenveränderungen durch "seltene Erden". *Schweiz. med. Wschr.* 105: 1799-1801 (1975).

COAL WORKERS' PNEUMOCONIOSIS LESIONS AND THEIR CORRELATION TO DUST LOAD

V. VALLYATHAN • R. Althouse • F.H.Y. Green

National Institute for Occupational Safety and Health, Div. of Respiratory Disease Studies,
Morgantown, WV 26505, USA

ABSTRACT

The relationship between the development, type, and severity of CWP and the concentration and composition of dust burden in the lung has been a subject of great interest. Several studies have shown that the concentration of quartz was the most important factor in the development of severe forms of CWP and pure silicosis. Since coal mine dust contains several minerals, it is important to know the relationship between these minerals and the development of various pulmonary lesions. Therefore, this study was undertaken to investigate the relationship between the type and severity of CWP with silica concentration, total mineral load, and coal dust load. We studied 120 coal miners and 21 non-coal miner autopsy lungs collected from Beckley, West Virginia, during 1960 to 1972 through consecutive autopsies. Whole lung sections prepared according to standard Gough procedure were reviewed and graded using NIOSH/CAP criteria. Concentrations of silica, total mineral dust load, and coal dust burden were determined in freeze-dried samples of the lung using standard protocols. Our findings indicate a good correlation between the type and severity of CWP and the concentration of total dust load. In addition, we also found that the proportions of silica and other mineral dust burden is an important factor in reducing the effects of quartz.

No Paper provided.

FEEDBACK OF CLEANED EXHAUST AIR INTO WORKPLACE ATMOSPHERES—EXPERIENCES ON TESTING EQUIPMENT

HELMUT BLOME, Dr. • Manfred Heimann • Wolfgang Pfeiffer

Occupational Safety Institute—BIA, Sankt Augustin, FRG

Under defined conditions, the feedback of cleaned exhaust air into workplace atmospheres is approved in the industry of the Federal Republic of Germany. Requirements to be met by capturing and precipitating systems are stipulated in technical regulations. These regulations differentiate according to:

- dust collecting machines and instruments for mobile use and
- central exhaust systems.

Dust collecting machines and instruments have to fulfil the conditions of a technical test. Occupational Safety Institute

(BIA) is an authorized test institute for industrial vacuum cleaners, exhaust sweeping machines and dust collectors. Industrial vacuum cleaners and exhaust sweeping machines are used for the removal of deposited dust. Dust collectors are used for the exhaustion and precipitation of suspended dust emitted from individual dust sources. Technical requirements to be met by these systems were stipulated in 1973 for the first time. Since then, a total of 450 systems has been tested, about 50 percent of them being industrial vacuum cleaners and 33 percent dust collectors. According to the size of these devices, suction volume flows range from about 100 to 4000 $m^3 \cdot h^{-1}$ (see Table I).

Table I
Dust Removal Equipment

equipment	application	exhaust flow rate [$m^3 \cdot h^{-1}$]	tested equipments	
			number	[%]
industrial vacuum cleaner	sucking up of deposited	100 - 1.000 (7.000)	220	49
exhaust sweeping machine	dust	200 - 1.000	82	18
dust collector	sucking off of airborne dust on machines	80 - 4.000 (11.000)	148	33
Summary (1973 - 8/88) :			450	100

Table II contains a survey of dust technique demands on these instruments. According to their use for the removal of dust of variable nocuousness, instruments are graded in different categories (dust classification). In general, demands increase from the top to the bottom of the list mainly referring to the required throughput.

With the exception of category L, the specific load per unit filter surface must not exceed $200 \text{ m}^3 \cdot \text{m}^{-2} \cdot \text{h}^{-1}$. In addition to requirements concerning the effects, demands with regard to the construction rise as well beginning at category L and ending with category V.

Any dust capturing machine has to be equipped with precipitators primarily supposed to protect the main filter from being damaged by sharp-edged or pointed objects.

Precipitators are frequently combined with dust collecting containers or are integral elements of them.

With the exception of category L, any system has to be provided with a control device.

1. Indicating in industrial vacuum cleaners the decrease of the average air velocity in the exhaust tube below

$15 \text{ m} \cdot \text{s}^{-1}$ (in this case, dust transport would no longer be maintained);

2. Indicating in exhaust sweeping machines that the low pressure in the broom chamber decreases below $50 \text{ N} \cdot \text{m}^{-2}$ so that dust may be emitted;
3. Ensuring in dust collectors that the volume flow—adjusted to the dust source—does not fall short of the required minimum. This function can be performed for instance by a suction air control flap installed between capturing element and dust collector system. The control flap is supposed to switch off the dust source (e.g. a brake lining processing machine) when the adjusted minimum value is reached.

The cleaning of systems graded in categories H, T and C is intended to separate the dust deposited on the filter and to transport it to the collecting basin. If filter change is possible without dust production, easy-change filters—obligatory for systems of category V—can be used alternatively.

Dust of systems in categories T, C and V has to be disposed of without dust occurrence, for example using densely locking,

Table II
Dust Removal Equipment
Effective Requirements

dust class	dust with limit values for occupational exposure	example	degree of penetration [%]	flow rate per m^2 filter plane [$\text{m}^3 \cdot \text{m}^{-2} \cdot \text{h}^{-1}$]
L - light	$> 1 [\text{mg} \cdot \text{m}^{-3}]$	chalk	< 5	≤ 500 (≤ 1000)
H - hazard	$> 0,1 [\text{mg} \cdot \text{m}^{-3}]$ incl. L	quartz	< 1	≤ 200
T - toxic	toxic incl. L and H	lead	$< 0,5$	≤ 200
C - cancer	carcinogenic incl. L, H and T	asbestos	$< 0,1$	≤ 200
V - virus	pathogens incl. L, H, T and C	virus	$< 0,05$	≤ 200

robust plastic boxes incorporated in dust collecting containers.

Density checking of systems and the checking of operating instructions are important since dust disposal without risk cannot solely be ensured by construction measures but frequently is only possible in combination with instruction and their observation.

Systems are provided with a certificate of three years validity which certifies the suitability for the specific category of clean air feedback after each of dust technique requirements has been met.

At the beginning, BIA only tested requirements regarding dust technique. Since 1979, noise emission of machines and instruments has been checked as well.

Increasingly, manufacturers are demanding an overall safety technique test including mechanical and electrical safety. In case of positive test results, BIA certifies the fulfilment of any presently valid safety technique condition. Each year, the institute publishes a list of systems tested with positive results. At present, about 90 percent of devices meet overall safety technique requirements.

Small dust collectors—referred to the space volume of workplaces—are in general operated with low air volume flows. In accordance with valid regulations, air recycled from small dust collectors must only amount to 1/10 of the fresh air volume flow for working areas.

When different exhaust devices are connected with a central dust capturing system and exhaust air has to be fed back to workplace atmosphere after cleaning, the conditions are different. In this case, the proportion of recycled air is mostly distinctly above 1/10 of the fresh air volume flow.

The cleaned air of stationary dust collectors can only be fed back to working areas after having obtained the permission of authorities in charge of occupational protection or of professional associations. Permission is granted under the condition that the quartz fine dust concentration in cleaned air does not exceed 1/3 of the maximum workplace concentration value. Since a permanent control of quartz fine dust concentrations in recycled air is hardly realizable by technical means, an evaluation of systems after initial operation has to ensure that the required threshold value is not exceeded and that this condition can be constantly maintained.

In general, systems are evaluated after a certain period of operation. This time comprises between 4 and 6 weeks, i.e. when filters in the precipitator obtain their optimum efficiency.

An assessment of the system includes the concentration determination in recycled air and in workplace atmospheres. At the same time, the accordance of system performance data (volume flow, pressure etc.) with actual values (nominal values) is checked.

Parallel to measurements of recycled air, quartz fine dust concentrations in workplace atmospheres are determined to control whether emitted dusts are sufficiently captured by exhausting equipment. If threshold values for quartz fine dust

in workplace atmospheres as well as in recycled air are observed, an exceptional permission for operating the systems with clean air feedback is given.

An exceptional permission is not granted if technical data of the collector do not guarantee a permanently safe observation of threshold levels for clean air. Cleaning type of precipitating elements (filters) and the so-called load per unit filter surface (air volume flow, referred to filter surface) are essential.

The pressure drop within the precipitator increases if dust deposits on filter elements grow higher. If dust is not extracted on time the suction volume may decrease due to higher pressure loss, thus deteriorating dust capture.

The risk of a higher dust exposure by reduced capturing degrees is the consequence.

Precipitating elements can either be cleaned continuously during operation (on-line cleaning) or discontinuously while out of operation (off-line cleaning). Continuous cleaning is mainly performed by a pressure drop-dependent control system or by a time control system. Discontinuous cleaning demands the observation of the maximum pressure loss between cleaning intervals stipulated for proper operation. To maintain the safe function of systems a continuous cleaning is preferable. The pressure loss in units that are discontinuously cleaned has to be registered and indicated. If pressure loss increases above maximum level, suitable measures to prevent risks have to be taken. For example, a special control system interrupts dust emitting procedures and restarts them after cleaning.

Another parameter of operational safety is the filter surface load. A too high filter surface load results in:

- premature filter wear and
- worse characteristics to cleaning.

Filter surface load must not exceed levels between 80 and 100 $\text{m}^3 \cdot \text{m}^{-2} \cdot \text{h}^{-1}$.

Test Results of Dust Measurements

BIA has performed numerous measurements in various industrial plants. Clean air as well as harmful material concentrations in workplace atmospheres were measured to evaluate the efficiency of dust capture in addition to dust precipitation.

1. Workplace atmospheres in foundry iron casting cleaning rooms.

After 7 foundries had been found to exceed the levels of workplace concentrations, new exhaust systems recycling clean air were installed. The evaluation showed average fine dust concentrations of 0.43 mg/m^3 and average quartz fine dust concentrations of 0.017 mg/m^3 in cleaned air. Levels varied between 1.33 mg/m^3 and 0.03 mg/m^3 for fine dust concentrations and between 0.05 mg/m^3 and 0.004 mg/m^3 for quartz fine dust concentrations.

Measuring results showed the observation of concentration threshold values for recycled air, partly the levels were even distinctly below these limits.

Measuring values for workplace atmospheres varied between 1.5 mg/m^3 and 0.3 mg/m^3 for the fine dust concentration and between 0.16 mg/m^3 and 0.03 mg/m^3 for the quartz fine dust concentration, thus proving the efficiency of exhaust systems.

2. Workplace atmospheres in rooms for the hand-grinding of quartz containing construction elements.

In some inspected enterprises, grinding was performed in front of an exhaust wall with water screen. Dust included in suction air was supposed to be precipitated in the water screen. The air cleaned in this way was led to workplace atmospheres via a mist collector. Concentration measurements in the whole working room showed the following results: the average fine dust concentration was 1.5 mg/m^3 , the quartz fine dust concentration of 0.3 mg/m^3 was on the average twice higher than that of the maximum workplace concentration value of

0.15 mg/m^3 . In recycled air a fine dust concentration of 1.6 mg/m^3 and a quartz fine dust concentration of 0.32 mg/m^3 were measured. This outcome was the reason to demand the system to be improved.

The exhaust wall was replaced by a cabin. Subsequent measurements had the following results: in the working area, the fine dust concentration could be reduced to 0.11 mg/m^3 on the average and the quartz fine dust concentration to 0.01 mg/m^3 . At the same time, the fine dust concentration of recycled air decreased to 0.1 mg/m^3 and the quartz fine dust concentration to 0.004 mg/m^3 compared to the approved quartz fine dust clean air concentration of 0.05 mg/m^3 (1/3 of the maximum workplace concentration value). The outcome was decisive for granting an exceptional permission to operate the system since the limits for clean air as well as those for workplace atmospheres were observed.

EXPOSURES OF END-USERS TO AIRBORNE CONCENTRATIONS OF FIBROUS GLASS DURING INSTALLATION OF INSULATION PRODUCTS AND FABRICATION OPERATIONS

C.W. AXTEN* • J.R. Bender* • P.F. Aubourg† • T.R. Jabobs† • M.R. Kalinowski† • E.J. Klotz†

*Owens-Corning Fiberglas Corp., Fiberglas Tower, T/11, Toledo, OH 45659

†Owens-Corning Fiberglas Corp., Technical Center, P.O. Box 415, Granville, OH 43023, USA

INTRODUCTION

Owens-Corning Fiberglas has supported for many years a comprehensive industrial hygiene program for the evaluation of employee exposures to fibrous glass and other airborne contaminants in the Corporation's manufacturing facilities. We have also collected and analyzed data on the exposures of end-users of the Company's products.

In order to expand the data on end-users, an extensive study of end-users' exposures to fibrous glass during the installation, fabrication, and use of the Company's products was instituted. This paper presents the results of this study, and compares exposures observed in end use applications to those normally seen in manufacturing situations.

MATERIALS AND METHODS

Several hundred paired personal and area samples were collected in parallel on 0.8 micron pore size mixed cellulose ester filters mounted in 37 mm diameter polystyrene plastic cassettes with 16 mm non-electrically conductive extension cowls (i.e. NIOSH P&CAM 239 sampling method¹) and in 25 mm diameter polystyrene plastic cassettes with 50 mm electronically conductive extension cowls (i.e. NIOSH 7400 sampling method²). This correlative sampling was performed since the majority of fibrous glass monitoring results obtained in the "in-plant" program were collected using the NIOSH P&CAM 239 Procedure. It was felt that if comparisons were to be made between the "in-plant" and end-user data, both sampling methodologies should be employed.

During the initial phase of the study, additional samples were collected using 0.45 polycarbonate filters mounted in 37 mm diameter cassettes with 16 mm extensions cowls. However, this approach was quickly discontinued due to the poor fiber retention (i.e. fibers were collected but were easily dislodged during transportation).

All samples were collected at a flow rate of two liters per minute (i.e. 2.0 l/m) using constant flow sampling pumps. The pumps were calibrated, with the filter and sampling train in line, before and after sampling using a precision rotameter calibrated against a primary standard (i.e. soap bubble meter for volumetric rate of air flow).

Applications sampled included installation operations involv-

ing traditional insulation products (i.e. batts, blankets, rolls, and loose fill insulation); and fabrication operations involving duct board, duct liner and other industrial products (e.g. range insulation, mobile home insulation, etc.). Both residential and commercial sites were evaluated.

All sample filters were mounted using the acetone/triacetin clearing method and analyzed via phase contrast optical microscopy (PCOM) at a magnification of 400X. Fiber counts for all sample filters were derived utilizing the procedures specified in both the NIOSH P&CAM 239 method as well as the NIOSH 7400 "A" method (i.e. all fibers > 5 microns in length with aspect ratios equal to or greater than 3:1 were counted). Glass fibers were differentiated from other fibers by morphology and shape recognition. For fibers that could not be easily identified by phase contrast microscopy, the samples were cross checked using polarized light microscopy. Additionally, fiber length and diameter measurements were determined for some of the samples.

To address fiber adherence to the sampling cowls, after filter removal, all cowls were rinsed with 25% isopropanol in distilled water. Rinse solutions were then filtered through 0.4 micron polycarbonate filters, and analyzed using the counting procedures described above.

To determine if some of the glass fibers present on the filters were too fine to be detected by optical microscopy, 40 filters were also counted by scanning electron microscopy. Two randomly chosen samples were also counted by transmission electron microscopy. Both analyses incorporated the "A" counting rules.

After all sample results had been obtained, matched pair results were analyzed statistically to determine differences between the 37 and 25 mm diameter filters. Natural log transformed data were used to determine statistical difference at the 0.05 significance level.

RESULTS AND DISCUSSION

The sample results obtained from this study are presented in Tables I and II and Figures 1 and 2. Because a significant concentration of fibers were found adhering to the sidewalls of the cassettes (i.e. NIOSH P&CAM 239 Procedure) and to the sampling cowls (NIOSH 7400 Procedure), these fibers were

Table I
Total Airborne Fiber Concentrations
 Obtained by Using the NIOSH P&CAM 239 and 7400 "A" Methods
 (Combined), Fibers per Cubic Centimeter

ITEM	ALL FIBERS							
	Filters				Filters and Cowls			
	# Samples	Exp. Value	95% LL	95% UL	# Samples	Exp. Value	95% LL	95% UL
Plants	75	0.024	0.018	0.030	71	0.031	0.020	0.043
Batts - Installers	60	0.17	0.12	0.22	60	0.24	0.18	0.31
Loose Fill Loaders								
Cubed	86	0.23	0.18	0.28	86	0.37	0.31	0.43
Milled	18	0.37	0.29	0.56	18	0.56	0.34	0.81
Loose Fill Installers								
Cubed	88	0.75	0.66	0.83	87	1.0	0.87	1.1
Milled	20	0.91	0.51	1.4	20	1.3	0.77	1.8

Table II
Total Airborne Fiber Concentrations
 Obtained by Using the NIOSH P&CAM 239 and 7400 "A" Methods
 (Combined), Fibers per Cubic Centimeter

ITEM	ALL FIBERS							
	Filters				Filters and Cowls			
	# Samples	Exp. Value	95% LL	95% UL	# Samples	Exp. Value	95% LL	95% UL
Fabricators	44	0.11	0.053	0.14	44	0.15	0.11	0.19
Metal Building Ins	26	0.034	0.026	0.042	26	0.045	0.030	0.059
Mobile Home	20	0.11	0.062	0.17	20	0.17	0.095	0.24
Pipe	19	0.12	0.067	0.18	19	0.16	0.085	0.23
Range	25	0.054	0.034	0.075	25	0.069	0.041	0.097
Duct Liner	24	0.024	0.013	0.036	24	0.030	0.013	0.048
Water Heater	13	0.037	0.022	0.053	13	0.047	0.022	0.071
Flex Duct	60	0.062	0.049	0.074	60	0.078	0.060	0.096

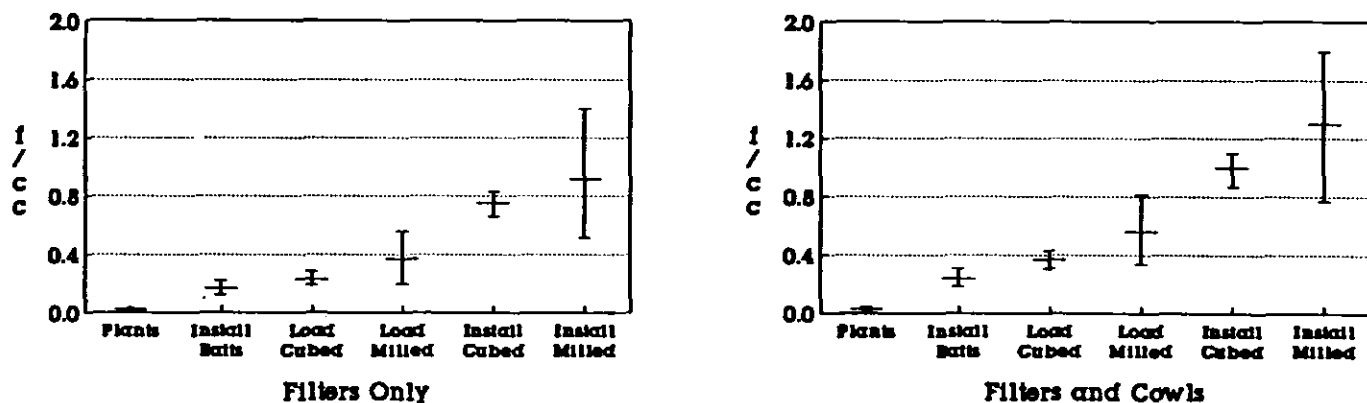

Figure 1.

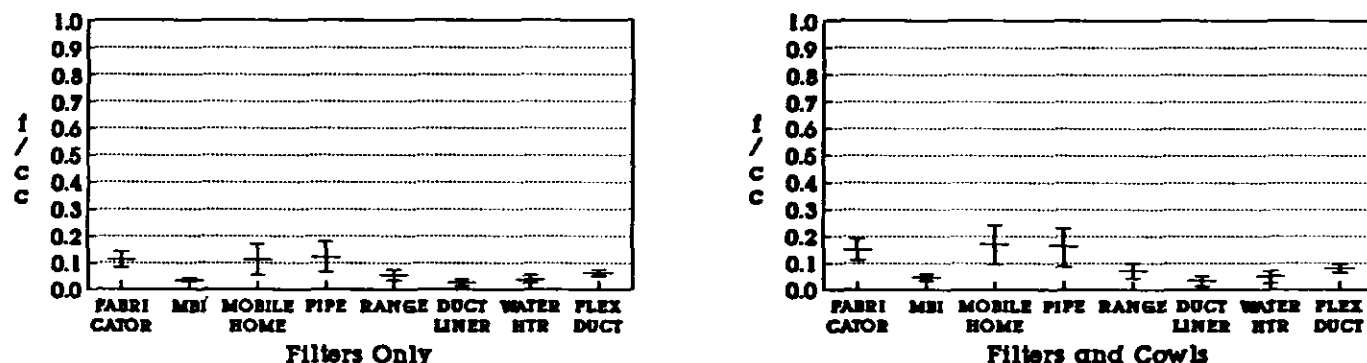

Figure 2.

also counted. Results are reported as filter only and as filter and cowl combined. Statistical analysis indicated that there was no difference between the total fiber results obtained from the NIOSH P&CAM 239 and 7400 methods using the "A" counting rules for either filters only or filter and cowls combined. Therefore, results from the two sampling methodologies were combined for the data summary and statistical analysis.

As indicated in Table I and Figure 1, the mean total fiber (both glass fiber and all other fiber) exposures of employees in OCF production facilities involved in the manufacture of fibrous glass insulation products were 0.024 f/cc for filters only and 0.03 f/cc for filters and cowls combined. Further analyses revealed that 70 to 75% were glass fibers. Of the glass fibers, 60% were of a respirable size. (Respirable fibers are defined as those with diameters < 3.5 microns, lengths of 5 to 250 microns, and length to diameter ratios of 3:1). These exposures are representative of 8-hour time weighted average exposures.

The mean total fiber (both glass fiber and all other fiber) exposures of individuals installing batt, blanket, and roll insulation was 0.17 f/cc for filters only and 0.24 f/cc for filters and cowls combined. Additional analyses revealed that 50% were

glass fibers. Of the glass fibers, 75% were of a respirable size. As anticipated, loose fill loaders and installers were exposed to higher mean concentrations of total fiber in the range of 0.23 to 0.91 f/cc for filters only and 0.37 to 1.3 f/cc for filters and cowls combined, primarily due to the nature of the installation process. Additional analyses revealed that 50 to 75% were glass fibers. Of the glass fibers, 50 to 75% were of a respirable size. These exposures represent those measured during the actual installation operations and not during transportation and preparation activities. Therefore, actual 8-hour time weighted average exposures will be less than those reported above.

Exposures of employees involved in installing a variety of OCF products are indicated in Table II and Figure 2. Mean total fiber (both glass fiber and all other fiber) ranged from 0.024 f/cc to 0.12 f/cc for filters only and 0.03 to 0.17 f/cc for filters and cowls combined.

Scanning electron microscopy analysis of 40 samples, collected at OCF plants and during installation of OCF products, revealed that all fibers (i.e. length > 5 micron and length to width ratio > 3:1) are seen by phase contrast microscopy. Two samples analyzed by transmission electron microscopy also revealed that all fibers are seen by phase contrast microscopy.

CONCLUSIONS AND RECOMMENDATIONS

Total fiber exposures of both OCF insulation production employees and end users are appreciably lower than the NIOSH recommended exposure limit for glass fibers (i.e. 3 f/cc). Statistical analysis indicated that there was no difference between the total fiber results obtained from the NIOSH P&CAM 239 and 7400 methods using the "A" counting rules. A significant concentration of fibers were found adhering to the sidewalls of the cassettes (i.e. NIOSH P&CAM 239 Procedure) and to the sampling cowls (NIOSH 7400 Procedure).

There was no statistical difference between the total fiber results obtained from the NIOSH P&CAM 239 method when combining fibers counted from the filters and cassette sidewalls and the total fiber results obtained from the NIOSH 7400 method when combining fibers counted from the filters

and cowls. Furthermore, scanning electron microscopy analysis revealed that all fibers (i.e. length > 5 micron and length to width ratio > 3:1) are seen by phase contrast microscopy. Additional research is needed on the optical microscopy methodologies for determining respirable fibers and for identifying glass fibers.

REFERENCES

1. Analytical Method P&CAM 239 for "Asbestos Fibers in Air" in *NIOSH Manual of Analytical Methods—Second Edition*, DHEW (NIOSH) Publication No. 77-157, U.S. Department of Health, Education and Welfare, Public Health Service, Centers for Disease Control, National Institute for Occupational Safety and Health.
2. Analytical Method 7400 for "Fibers" in *NIOSH Manual of Analytical Methods—Third Edition*, DHHS (NIOSH) Publication No. 84-100, U.S. Department of Health and Human Services, Public Health Service, Centers for Disease Control, National Institute for Occupational Safety and Health.

EXPOSURE OF WORKERS TO RESPIRATORY HAZARDS AT COLUMBUS COAL AND REFUSE MUNICIPAL ELECTRIC PLANT

IBRAHIM M. SOBEIH, MSPH

Columbus Health Department, Columbus, Ohio, USA

BACKGROUND

The Columbus Refuse and Coal Fired Municipal Electric Plant (RCFMEP) is the largest refuse derived fuel plant in the United States. It became operational in June of 1983. The facility occupies 52 acres, is made up of an eleven story boiler house, a shredder station and a crane area. The boiler house contains six balanced draft boilers where a mixture of 90:10 refuse and coal is burned to generate electricity with a maximum generating capacity of 90 megawatts. These boilers consume between 500,000–750,000 tons of refuse generated by Greater Metropolitan Columbus and Franklin County annually.

The plant is a 24 hour and 365 days per year operation with the majority of the work performed by three workshifts and a workforce of nearly 200 employees.

PROBLEM DESCRIPTION

The RCFMEP has striven to apply existing technologies to new uses, in this case the use of coal fired power equipment for reclaiming energy from refuse. The use of this ill-defined and constantly changing fuel has resulted in a work environment that presents numerous and varied worker exposures to both identified and unidentified contaminants. Since the primary fuel used is refuse, a reasonable assumption is that most anything that is likely to be discarded in the Columbus Metropolitan area and Franklin County, may at some time appear at the plant.

The processing and incinerating of refuse, mechanical and electrical maintenance of the plant, the disposal of the fly and bottom ash, and the production of steam to generate electricity causes a host of hazards to workers. These hazards include microbiological agents, heat, cold, noise, vibration, dust, heavy metals, pesticides, organics, dioxins, free silica and possibly asbestos in addition to stress and ergonomic problems.

Of these hazards free crystalline silica, respirable dust, cadmium, beryllium, arsenic, nickel, and chromium (total and hexavalent) are the respiratory hazards considered in this investigation which is a part of an ongoing comprehensive industrial hygiene and medical surveillance of the plant workforce. The reason for evaluating the adverse health effects and characterization of the airborne levels of these contaminants is their proven capability of causing injury to the lungs by either irritation, scarring or cancer formation.^{7,8,9,10,11,12}

METHODOLOGY

Industrial Hygiene

Respiratory hazards under investigation have been chosen based upon analytical results of bulk ash and dust samples collected by NIOSH investigators from eight locations in the plant during a survey in March 1985.¹ In this investigation, bulk ash and dust samples were analyzed for their content of thirty one chemical elements, free silica (quartz) and cristobalite. Cadmium, chromium, beryllium, arsenic, nickel, respirable dust and free silica (quartz) were chosen based upon their presence in the ash and dust, and their definite toxic nature against the pulmonary system.

To characterize levels of the airborne respiratory hazards under study in areas of the plant, the plant was divided into eleven major areas. They are the first floor—quench basins, second floor—boilers, third floor—electrostatic precipitators, first floor B—preheater room, fourth floor—refuse feed, fifth floor, seventh floor, ninth floor, crane area, shredder station and office. The workforce was divided into mechanical maintenance, electrical maintenance, crane operators and area workers, steam operating engineers, boiler operators, laborers-quench basins area, laborers-ash tunnels and system, laborers-shredder house, and laborers-refuse feed area. Mechanical maintenance group works in two twelve hour shifts, the shredder station is operational only for the day shift, office personnel work only the day shift, whereas the rest of the workforce performs the duties on the basis of three eight hour shifts.

Area air sampling was carried out during January, November and December of 1987 where as personal monitoring of the first shift was carried out during January, November and December of 1987 and once per month for 1988 and is an ongoing process to the end of this year. Second and third shifts have been monitored since January of 1988 and will continue to the end of this year.

Respirable dust, free silica (quartz), cadmium, arsenic, nickel, beryllium, chromium (total) and chromium VI were air sampled. These samples were shipped and analyzed by NATLSCO Industrial Hygiene Laboratory in Chicago, Illinois, for the period prior to June 30, 1988 and Clayton Environmental Consultants Industrial Hygiene Laboratory in Novi, Michigan beginning July 1, 1988. Sampling and analysis were performed according to NIOSH Manual of Analytical Methods, third edition.²

Medical Surveillance

New workers are screened during the probationary period of employment with emphasis on the respiratory and cardiovascular systems by means of posterior-anterior X-ray, pulmonary function testing, electrocardiogram and blood chemistry to determine the health status of the worker and his/her ability to use a respirator and work with the forementioned hazards. Emphasis are on new workers at this point where nearly 50 workers have been examined. Eventually all employees, permanent and new, will undergo medical evaluation to establish baseline medical data to be followed by an annual follow-up, the purpose of which is to prospectively follow the health of all workers.

STANDARDS AND CRITERIA OF EXPOSURE

Threshold Limit Values (TLVs) of the American Conference of Governmental Industrial Hygienists (ACGIH),³ National Institute for Occupational Safety and Health (NIOSH) Recommended Exposure Limits (RELs)⁴ and the Occupational Safety and Health Administration (OSHA) Permissible Exposure Limits (PELs)⁵ are the sources of standards and criteria of exposure. Table I shows the three standards of exposure to cadmium, nickel, arsenic, chromium-total, chromium VI, respirable dust, beryllium and crystalline free silica (quartz).

RESULTS AND DISCUSSION

Evaluation of airborne arsenic, cadmium, total chromium, beryllium, nickel, respirable dust and free silica in several locations in the plant was attempted to try to detect gross variations in the airborne levels of these contaminants in those areas (Tables II and III). These contaminants were either not detected or below their respective OSHA PELs, NIOSH RELs

and ACGIH TLVs and without significant variations between areas. Therefore the idea of characterizing workers' exposure on the basis of estimating area airborne levels of contaminants was abandoned.

Evaluation of workers' exposure to the forementioned contaminants on the basis of breathing zone or personal sampling proved to be more useful. Since the plant operation is a 24 hour operation with work performed in three 8-hour workshifts in the most part, evaluation of personnel was performed accordingly. Concerning workers' exposure to hexavalent chromium, airborne levels of chromium VI were within the OSHA PEL-TWA of 400 $\mu\text{g}/\text{m}^3$ and ACGIH TLV-TWA of 50 $\mu\text{g}/\text{m}^3$ for the three shifts and all worker groups (Table IV). However, the NIOSH REL-TWA of 1 $\mu\text{g}/\text{m}^3$ was exceeded in several samples. First shift mechanical maintenance, laborers-quench basin, laborers-shredder house personnel exposure exceeded the NIOSH REL-TWA with levels of 2.2, 1.8 and 1.2 $\mu\text{g}/\text{m}^3$ respectively. Of the second shift personnel only steam operating engineers group exceeded the NIOSH REL-TWA at 2.7 $\mu\text{g}/\text{m}^3$, whereas in the third shift only laborers-ash system group exceeded NIOSH REL-TWA at 1.9 $\mu\text{g}/\text{m}^3$. A 1985 NIOSH study reported chromium VI levels of ND-.8 $\mu\text{g}/\text{m}^3$ from 25 samples with none of the levels exceeding the three standards.¹

Breathing zone samples of the three shifts showed that all airborne arsenic levels fall below the OSHA PEL-TWA of 10 $\mu\text{g}/\text{m}^3$ and ACGIH TLV-TWA of 200 $\mu\text{g}/\text{m}^3$ (Table V A). However, the NIOSH REL-TWA of 2 $\mu\text{g}/\text{m}^3$ was exceeded once where a second shift boiler operator breathing zone sample showed arsenic levels of 5.8 $\mu\text{g}/\text{m}^3$. The Industrial Commission of Ohio Survey of August 1984 showed levels of arsenic of 0.8-54 $\mu\text{g}/\text{m}^3$ in five samples where ACGIH

Table I
Standards and Exposure Evaluation Criteria

CONTAMINANT	NIOSH REL-TWA ($\mu\text{g}/\text{m}^3$)	OSHA PEL-TWA** ($\mu\text{g}/\text{m}^3$)	ACGIH TLV-TWA ($\mu\text{g}/\text{m}^3$)
Cadmium	40	200	50
Arsenic	2	10	200
Nickel	15	1,000	1,000
Chromium VI	1	100	50
Beryllium	0.5	2	2
Chromium (Total)*	25	1,000	500
Respirable Dust	5,000	5,000	5,000
Crystalline Silica (Quartz)	50	100	100

* Includes chromium metal, chromium II compounds and chromium III compounds as chromium

** Revised exposure limit published by OSHA June 7, 1988

Table II
Area Air Samples of Arsenic, Cadmium, Total Chromium, Beryllium and Nickel
CONCENTRATION RANGE (ug/m3)

AREA	n	DURATION RANGE (MINUTES)	CONCENTRATION RANGE (ug/m3)				
			ARSENIC	CADMIUM	CHROMIUM	BERYLLIUM	NICKEL
First Floor-690 Level Quench Basins	2	422-476	0.18-0.23	ND-0.29	0.34-0.77	ND	ND-0.58
Second Floor-713 Level Boiler Floor	2	420-470	0.078-0.12	0.087-0.099	ND-2.3	ND	ND-0.18
Third Floor-723 Level Electrostatic Precipitators	2	415-462	0.080-0.62	0.92-.94	ND-1.6	ND	0.37-0.64
Fourth Floor-735 Level Refuse Feed & Boilers	3	404-460	0.038-0.091	ND-0.1	ND-1.5	ND	ND
Fifth Floor-757 Level	1	458	0.16	0.10	0.4	ND	ND
Seventh Floor-775 Level	2	391-452	ND-0.14	0.099-0.10	0.5-1.6	ND	ND
Eighth Floor-785 Level	2	380-440	ND-0.043	ND-0.043	1.0-1.4	ND	ND-.31
Nineth Floor-799 Level	2	388-447	ND-0.16	0.098-0.11	0.49-4.8	ND	0.20-0.32
Shredder House	3	372-453	ND-0.076	ND-0.11	ND-2.3	ND	ND-0.30
First Floor B- Preheater Room	1	420	0.30	0.095	1.1	ND	0.38
Office Area	1	387	ND	0.11	0.42	ND	0.21

ND - Not Detected

Table III
Area Air Samples of Respirable Dust and Free Silica (Quartz)

AREA	n	DURATION RANGE (MINUTES)	RESPIRABLE DUST RANGE (ug/m3)	SILICA (ug/m3)
First Floor - 690 Level	2	359 - 420	0.17 - 0.36	ND
Second Floor - Boiler Floor 713 Level	2	352 - 420	0.27 - 0.33	ND
Third Floor - Electrostatic Precipitators 732 Level	2	355 - 420	0.49 - 2.2	ND
Fourth Floor - 735 Level	3	350 - 420	0.013 - 0.72	ND
Fifth Floor - 757 Level	1	336	0.37	ND
Seventh Floor - 775 Level	2	327 - 400	0.22 - 0.29	ND
Eighth Floor - 785 Level	2	347 - 400	0.16 - 0.32	ND
Ninth Floor - 799 Level	2	323 - 396	0.29 - 0.59	ND
Shredder House	4	348 - 453	0.031 - 0.088	ND
First Floor B Preheater Room	1	420	0.066	ND

ND - Not Detected

Table IV
Personal Air Samples of Hexavalent Chromium for the Three Work Shifts

WORKER GROUP	n			DURATION RANGE (MINUTES)			CONCENTRATION RANGE (ug/m ³)		
	1ST SHIFT	2ND SHIFT	3RD SHIFT	1ST SHIFT	2ND SHIFT	3RD SHIFT	1ST SHIFT	2ND SHIFT	3RD SHIFT
Mechanical Maintenance	3	3	-	414-681	720-820	-	ND-2.2	ND-0.56	-
Laborers - Quench Basins	2	3	2	360-480	480	480	ND-1.8	ND-0.98	.30-.76
Crane Operators and Area	2	2	1	352-388	360	480	0.27-0.85	ND-.75	0.36
Boiler Operators	5	4	5	388-420	230-480	480	0.27-.82	ND-.94	ND-.73
Electrical Maintenance	3	1	2	392-400	480	464-480	ND-.54	ND	ND-.43
Laborers - Refuse Feed	2	2	3	396-420	480	480	.24-.45	ND-.47	ND-.38
Laborers - Shredder House	5	-	-	384-720	-	-	.31-1.2	-	-
Steam Operating Engineers	3	2	3	392-461	455-480	480	ND	ND-2.7	ND
Laborer - Ash System	2	1	2	400-420	480	261-480	0.33-0.54	0.38	.91-1.9

ND - Not Detected

* There is no third shift, rather there are two 12 hour shifts

** Laborers of the shredder house work only the first shift

Table V A
Personal Air Samples of the Three Work Shifts for Arsenic

WORKER GROUP	n			DURATION RANGE (MINUTES)			ARSENIC CONCENTRATION RANGE (ug/m ³)		
	1ST SHIFT	2ND SHIFT	3RD SHIFT	1ST SHIFT	2ND SHIFT	3RD SHIFT	1ST SHIFT	2ND SHIFT	3RD SHIFT
Mechanical Maintenance*	5	3	-	217-455	700-720	-	.14-.47	ND-.26	-
Electrical Maintenance	6	2	2	354-465	456-480	470-480	ND-.48	ND	ND
Steam Operating Engineers	4	2	3	420-476	480	381-480	ND-.11	ND	ND
Boiler Operators	6	3	5	321-477	480	401-480	ND-.41	ND-5.8	ND
Crane Operators & Area	4	2	1	420-473	360-480	480	ND	ND	ND
Laborers-Shredder House**	9	-	-	346-450	-	-	ND-.18	-	-
Laborers Quench Basins	5	3	3	291-491	480	369-480	ND-.21	ND-.60	ND-.81
Laborers Refuse Feed	2	2	3	420-450	480	335-480	ND	ND	ND-.25
Laborers-Ash System	4	2	1	320-480	359-480	480	0.10-0.70	.19-.40	.24

ND - Not Detected

* There is no third shift, rather there are two 12 hour shifts

** Laborers of the shredder house work only the first shift

arsenic standard was not exceeded. However, NIOSH standard was exceeded in three of four samples and OSHA standard was exceeded in two samples.⁶ As for cadmium, airborne levels were all below the OSHA PEL-TWA of 200 $\mu\text{g}/\text{m}^3$ and with the exception of one sample all were below the NIOSH REL-TWA of 40 $\mu\text{g}/\text{m}^3$ (Table V B). The one sample that exceeded NIOSH REL-TWA described the exposure of a first shift electrical maintenance worker with 64 $\mu\text{g}/\text{m}^3$. On the other hand, all samples with the exception of two were below the ACGIH TVL-TWA of 5 $\mu\text{g}/\text{m}^3$, where a first shift electrical maintenance worker and a second shift boiler operator exposure exceeded ACGIH TVL-TWA at 64 and 11 $\mu\text{g}/\text{m}^3$ respectively. The NIOSH study showed airborne cadmium levels of ND-18 $\mu\text{g}/\text{m}^3$ in 38 samples with none of the samples exceeding the three standards.¹ The Industrial Commission of Ohio study reported airborne cadmium levels of 0.4-25 $\mu\text{g}/\text{m}^3$ in 5 samples with none of the levels exceeding the three standards.⁶

Total chromium airborne levels were at or below the NIOSH REL-TWA of 25 $\mu\text{g}/\text{m}^3$, the OSHA PEL-TWA of 1000 $\mu\text{g}/\text{m}^3$ and the ACGIH TVL-TWA of 500 $\mu\text{g}/\text{m}^3$ (Table V C). The Industrial Commission of Ohio study reported airborne total chromium levels of 0.4-15 $\mu\text{g}/\text{m}^3$ with none of the samples exceeding the three standards.⁶ Similarly, beryllium airborne levels were below NIOSH REL-TWA of 0.5 $\mu\text{g}/\text{m}^3$, OSHA REL-TWA of 2 $\mu\text{g}/\text{m}^3$ and ACGIH TLV-TWA of 2 $\mu\text{g}/\text{m}^3$ for all shifts and worker groups (Table V D). For nickel, airborne levels were below the OSHA PEL-TWA and ACGIH TLV-TWA of 1000 $\mu\text{g}/\text{m}^3$ for all shifts

and worker groups (Table V E). However, NIOSH REL-TWA of 15 $\mu\text{g}/\text{m}^3$ was exceeded twice where a first shift electrical maintenance worker and second shift boiler operator showed exposures of 16 and 24 $\mu\text{g}/\text{m}^3$ respectively. The NIOSH study reported airborne nickel levels of ND-11 in 38 samples where none of the samples exceeded the three standards.⁴

Respirable dust levels were below OSHA PEL-TWA of 5 mg/m^3 , NIOSH REL-TWA of 5 mg/m^3 and ACGIH TLV-TWA of 10 mg/m^3 with the exception of two situations (Table VI A). In these two situations, a first shift electrical maintenance worker and a second shift worker in the cranes area were exposed to 1700 and 19 mg/m^3 respectively. The NIOSH study reported respirable dust levels of 0.09-14 mg/m^3 in 29 samples with only one sample exceeding the three standards.¹ As for crystalline silica (quartz), airborne levels of this contaminant were below the ACGIH TLV-TWA of 100 $\mu\text{g}/\text{m}^3$ and NIOSH REL-TWA of 50 $\mu\text{g}/\text{m}^3$ with the exception of one instance (Table VI B). In this situation a worker in the crane area was exposed to 220 $\mu\text{g}/\text{m}^3$.

It is obvious from the personal sampling data that exposure patterns are not highly unpredictable. This is true since the majority of employees do not perform the exact same duties and are not present in the exact same location every day. In addition, the major groups, mechanical maintenance, electrical maintenance, boiler operators rovers and steam operating engineers rovers perform duties that are different from one day to the next. Perhaps the most important factor

Table V B
Personal Air Samples of the Three Work Shifts for Cadmium

WORKER GROUP	n			DURATION RANGE (MINUTES)			CADMIUM CONCENTRATION RANGE ($\mu\text{g}/\text{m}^3$)		
	1ST SHIFT	2ND SHIFT	3RD SHIFT	1ST SHIFT	2ND SHIFT	3RD SHIFT	1ST SHIFT	2ND SHIFT	3RD SHIFT
Mechanical Maintenance*	5	3	-	217-455	700-720	-	ND-.92	ND-.79	-
Electrical Maintenance	6	2	2	354-465	456-480	470-480	ND-64	ND	ND
Steam Operating Engineers	4	2	3	420-476	480	381-480	ND	ND	ND
Boiler Operators	6	3	5	321-477	480	401-480	ND-.18	ND	ND
Crane Operators & Area	4	2	1	420-473	360-480	480	ND-.45	ND-11	ND-.54
Laborers-Shredder House**	9	-	-	346-450	-	-	ND	-	-
Laborers Quench Basins	5	3	3	291-491	480	369-480	ND-.38	ND-1.4	ND-1.4
Laborers Refuse Feed	2	2	3	420-450	480	335-480	ND	ND	ND-.11
Laborers-Ash System	4	2	1	320-480	359-480	480	ND-1.6	.21-.31	.45

ND - Not Detected

*. There is no third shift, rather there are two 12 hour shifts

** Laborers of the shredder house work only the first shift

Table V C
Personal Air Samples of the Three Work Shifts for Chromium

WORKER GROUP	n			DURATION RANGE (MINUTES)			CHROMIUM CONCENTRATION RANGE (ug/m ³)		
	1ST SHIFT	2ND SHIFT	3RD SHIFT	1ST SHIFT	2ND SHIFT	3RD SHIFT	1ST SHIFT	2ND SHIFT	3RD SHIFT
Mechanical Maintenance*	5	3	-	217-455	700-720	-	.30-14	.71-14	-
Electrical Maintenance	6	2	2	354-465	456-480	470-480	ND-16	ND-.23	ND-.55
Steam Operating Engineers	4	2	3	420-476	480	381-480	ND-2.9	ND-.22	ND-1.0
Boiler Operators	6	3	5	321-477	480	401-480	ND-25	ND-11	ND-1.6
Crane Operators & Area	4	2	1	420-473	360-480	480	ND-.53	ND	ND
Laborers-Shredder House**	9	-	-	346-450	-	-	ND-.98	-	-
Laborers Quench Basins	5	3	3	291-491	480	369-480	.51-2.6	.54-3.0	ND-2.7
Laborers Refuse Feed	2	2	3	420-450	480	335-480	ND-1.5	.15-.22	ND-1.1
Laborers-Ash System	4	2	1	320-480	359-480	480	.36-3.6	.23-1.7	ND

ND - Not Detected

* There is no third shift, rather there are two 12 hour shifts

** Laborers of the shredder house work only the first shift

Table V D
Personal Air Samples of the Three Work Shifts for Beryllium

WORKER GROUP	n			DURATION RANGE (MINUTES)			BERYLLIUM CONCENTRATION RANGE (ug/m ³)		
	1ST SHIFT	2ND SHIFT	3RD SHIFT	1ST SHIFT	2ND SHIFT	3RD SHIFT	1ST SHIFT	2ND SHIFT	3RD SHIFT
Mechanical Maintenance*	5	3	-	217-455	700-720	-	ND	ND	-
Electrical Maintenance	6	2	2	354-465	456-480	470-480	ND-.40	ND	ND
Steam Operating Engineers	4	2	3	420-476	480	381-480	ND	ND	ND
Boiler Operators	6	3	5	321-477	480	401-480	ND	ND	ND
Crane Operators & Area	4	2	1	420-473	360-480	480	ND	ND	ND
Laborers-Shredder House**	9	-	-	346-450	-	-	ND	-	-
Laborers Quench Basins	5	3	3	291-491	480	369-480	ND	ND	ND-0.1
Laborers Refuse Feed	2	2	3	420-450	480	335-480	ND	ND	ND
Laborers-Ash System	4	2	1	320-480	359-480	480	ND	ND	ND

ND - Not Detected

* There is no third shift, rather there are two 12 hour shifts

** Laborers of the shredder house work only the first shift

Table V E
Personal Air Samples of the Three Work Shifts for Nickel

WORKER GROUP	n			DURATION RANGE (MINUTES)			NICKEL CONCENTRATION RANGE ($\mu\text{g}/\text{m}^3$)		
	1ST SHIFT	2ND SHIFT	3RD SHIFT	1ST SHIFT	2ND SHIFT	3RD SHIFT	1ST SHIFT	2ND SHIFT	3RD SHIFT
Mechanical Maintenance*	5	3	-	217-455	700-720	-	ND-.46	.23-5.3	-
Electrical Maintenance	6	2	2	354-465	456-480	470-480	ND-16	ND-.23	ND
Steam Operating Engineers	4	2	3	420-476	480	381-480	ND-.19	ND	ND
Boiler Operators	6	3	5	321-477	480	401-480	ND-1.2	ND-24	ND-.36
Crane Operators & Area	4	2	1	420-473	360-480	480	ND-.71	ND	ND
Laborers-Shredder House**	9	-	-	346-450	-	-	ND-1.4	-	-
Laborers Quench Basins	5	3	3	291-491	480	369-480	ND-1.1	.23-2.8	ND-.72
Laborers Refuse Feed	2	2	3	420-450	480	335-480	.37-.92	ND-.30	ND
Laborers-Ash System	4	2	1	320-480	359-480	480	.16-.83	ND-.23	0.15

ND - Not Detected

* There is no third shift, rather there are two 12 hour shifts

** Laborers of the shredder house work only the first shift

Table VI A
Personal Air Samples of Respirable Dust and Free Silica for the Three Work Shifts

JOB TITLE/GROUP	n			DURATION RANGE (MINUTES)			RESPIRABLE DUST CONCENTRATION RANGE (mg/m^3)		
	1ST SHIFT	2ND SHIFT	3RD SHIFT	1ST SHIFT	2ND SHIFT	3RD SHIFT	1ST SHIFT	2ND SHIFT	3RD SHIFT
Mechanical Maintenance*	3	4	-	420-707	670-820	-	0.10-1.2	ND-3.1	-
Electrical Maintenance	6	2	2	373-447	480	480	ND-1700	ND-.069	ND-.048
Steam Operating Engineers	2	2	4	448-473	480	480	ND-.24	ND-.16	ND-.27
Boiler Operators	5	4	5	231-480	480	445-480	.24-.50	ND-.26	.073-.70
Crane Operators & Area	2	2	1	237-497	390-480	480	.065-.072	.39-19	.30
Laborers-Shredder House**	8	-	-	333-480	-	-	.11-.51	-	-
Laborers-690 Level	5	3	4	420-496	480	480	.30-.83	.20-.67	.13-.30
Laborers-4th Floor	3	2	2	420-447	480	480	ND-.22	ND-.08	.07-.20
Laborers-Ash System	5	1	2	420-497	480	480	.20-1.7	.20	.07-.30

ND - Not Detected

* There is no third shift, rather there are two 12 hour shifts

** Laborers of the shredder house work only the first shift

Table VI B
Personal Air Samples of Respirable Dust and Free Silica for the Three Work Shifts

JOB TITLE/GROUP	n			DURATION RANGE (MINUTES)			FREE SILICA CONCENTRATION RANGE (mg/m ³)		
	1ST SHIFT	2ND SHIFT	3RD SHIFT	1ST SHIFT	2ND SHIFT	3RD SHIFT	1ST SHIFT	2ND SHIFT	3RD SHIFT
Mechanical Maintenance*	3	4	-	420-707	670-820	-	ND	ND	-
Electrical Maintenance	6	2	2	373-447	480	480	ND	ND	ND
Steam Operating Engineers	2	2	4	448-473	480	480	ND	ND	ND
Boiler Operators	5	4	5	231-480	480	445-480	ND	ND	ND
Crane Operators & Area	2	2	1	237-497	390-480	480	ND	ND-220	ND
Laborers-Shredder House**	8	-	-	333-480	-	-	ND-31	-	-
Laborers-690 Level	5	3	4	420-496	480	480	ND	ND	ND
Laborers-4th Floor	3	2	2	420-447	480	480	ND	ND	ND
Laborers-Ash System	5	1	2	420-497	480	480	ND	ND	ND

ND - Not Detected

* There is no third shift, rather there are two 12 hour shifts

** Laborers of the shredder house work only the first shift

in the exposure of personnel is the unpredictably variable nature of the refuse which makes it impossible to establish definite exposure trends.

Medical surveillance of workers is still at an infant stage, where only approximately 50 new workers have been examined for the purpose of establishing baseline medical data. This data includes X-ray, pulmonary function testing, electrocardiogram and blood chemistry where the majority of workers examined have been found with normal health. The goal of this medical screening program is to eventually establish baseline medical data on all employees followed with an annual follow-up medical examination to prospectively follow trends in the health of all employees.

REFERENCES

1. U.S. Department of Health and Human Services (1986). *NIOSH: Health Hazard Evaluation Report of the City of Columbus Refuse Coal Derived Fuel Power Plant*, March 4-8 and 12-14, 1985.
2. U.S. Department of Health and Human Services. *NIOSH: Manual of Analytical Methods*, 3rd Ed., 1st and 2nd Volumes. 1984.
3. American Conference of Governmental Industrial Hygienists (1988). *Threshold Limit Values and Biological Exposure Indices for 1987-88*.
4. U.S. Department of Health and Human Services (1986). *NIOSH Recommendations for Occupational Safety and Health Standards*. Morbidity and Mortality Weekly Report Supplement, Vol. 35:#15.
5. U.S. Department of Labor (1985). *Code of Federal Regulations: Labor*. 29-parts 1900-1910, revised June 1988.
6. Industrial Commission of Ohio (1984). *Industrial Hygiene Survey: Refuse Coal Fired Municipal Electric Plant*, August 6-9, 1984.
7. U.S. Department of Health, Education and Welfare (1973). *The Industrial Environment—Its Evaluation and Control*.
8. Carson, B.L., Ellis III, H.V., McCann, J.L.: *Toxicology and Biological Monitoring of Metals in Humans*. Lewis Publishers, Inc., Chelsea, Michigan. 1986.
9. Williams, P.L., Burson, J.L.: *Industrial Toxicology: Safety and Health Applications in the Workplace*. Lifetime Learning Publications, New York. 1985.
10. Gosselin, R.E., Smith, R.P., Hodge, H.C.: *Clinical Toxicology of Commercial Products*. 5th Ed., Williams and Wilkins, Baltimore. 1984.
11. Klaussen, C.D., Amdur, M.O., Doull, J.: *Casarett and Doull's Toxicology: The Basic Science of Poisons*, 3rd Ed., MacMillan Publishing Company, New York. 1986.
12. Patty's Industrial Hygiene and Toxicology. *Toxicology: Heavy Metals*, 3rd Revised Ed., Volume 2A: 1493-2060. 1981.

COMPARISON OF NUMBER AND RESPIRABLE MASS CONCENTRATION DETERMINATIONS

T. TOMB • R. Haney

Mine Safety and Health Administration, Pittsburgh, Pennsylvania, USA

INTRODUCTION

Regulations pertaining to Safety and Health Standards for Surface Metal and Nonmetal Mines; and for Underground Metal and Nonmetal Mines in the United States are specified in Title 30, CFR, Parts 56 and 57, respectively. In these parts of Title 30, exposure limits for airborne contaminants are based on the Threshold Limit Values (TLV) adopted by the ACGIH (American Conference of Governmental Industrial Hygienists) as set forth and explained in the 1973 Edition of the Conference's publication, entitled "TLVs Threshold Limit Values for Chemical Substances in Workroom Air Adopted by ACGIH for 1973." Exposure limits established in this edition for various mineral silicate dusts containing less than one percent quartz are based on the number of particles per cubic foot of air.

In the 1976 Edition of the "Threshold Limit Values for Chemical Substances in Workroom Air," limits based on the respirable mass of the dust per cubic meter of air that were supposedly equivalent to previously recommended limits based on the number of particles per cubic foot of air were published in Appendix G. The bases for establishing the equivalent mass concentration values were:

1. An empirical relationship, derived by Jacobson and Tomb,¹ that indicated 5.65 mppcf was approximately equal to 1 mg/m³ of respirable dust sampled with an Isleworth Gravimetric Dust Sampler, Type 113A.²
2. A relationship of 6 mppcf = 1 mg/m³ developed from a calculation that assumed that the average density for silica containing dust is approximately 2.5 grams per cubic centimeter and that the mass median diameter of particles collected in midget impinger samplers, (counted by the standard light field microscopic technique) and in respirable dust samplers is approximately 1.5 micrometers (μm).

In the 1986-87 Edition of the "Threshold Limit Values for Chemical Substances in Workroom Air" references to count standards were eliminated. Respirable mass standards listed were based on the above conversion or when a respirable hazard had not been documented a total dust standard of 10 mg/m³ was adopted. Additionally the recommended standard for respirable talc dust was reduced from 3 to 2 mg/m³. Documentation for the rationale of these changes has not been published.

Recognizing that an assessment based on a respirable mass

limit would: be more relevant to the health hazard; provide a method of assessing the quality of an environment which is simpler; be less expensive and be more reproducible than the count method; MSHA investigated the validity of the equivalent respirable mass limits recommended. This investigation was principally performed to provide documentation to support any legal actions that would result from the use of the recommended limits as "equivalent" standards.

The purpose of this paper was to investigate the validity of the equivalent respirable mass concentrations recommended. To accomplish this a review of the rationale published in the 1976 and subsequent TLV Handbooks was made. "Documentation of the Threshold Limit Values" was reviewed and empirical relationships were derived from comparative measurements obtained with a long running midget impinger and a respirable dust sampler.

PROCEDURES

To develop the empirical relationships, comparative measurements with the midget impinger and respirable dust samplers were obtained at operations mining or processing natural graphite, perlite, mica, diatomaceous earth and talc (nonasbestiform). Although soapstone was another mineral of interest, at the time of the study, no soapstone mines were operational.

Samples collected with the midget impinger were analyzed for number concentration using light-field microscopy following the Bureau of Mines³ standard microprojector technique. The results were reported as millions of particles per cubic foot. Respirable dust samples were weighed and the mass concentration of dust was determined and reported as milligrams of respirable dust per cubic meter of air sampled.

The respirable dust sampler was that typically utilized by MSHA's Metal and Nonmetal Mine enforcement personnel to assess the respirable mass concentration of dust in an environment. Airflow through the respirable dust sampling system was maintained constant at 1.7 liters per minute using either an MSA Model G, Bendix 3900 or Bendix BDX30 pump.

The various instruments used to obtain comparative measurements were assembled into a package. Each package contained two modified midget impinger samplers, two respirable dust samplers and a total dust sampler. The modification to the impinger consisted of replacing the standard

1 by 4.5 inch particle collection flask with a larger container that would permit extending the sampling time of the impinger from 20 minutes to four hours. Normally two packages, located at different sampling sites at a respective mineral processing operation, were used. The sampling time for comparative samples ranged from two to four hours. The number of comparative samples obtained for the respective minerals varied.

The total dust samples were collected with a sampling system similar to that used to collect the respirable dust samples, but without the 10 mm nylon cyclone attached. Total dust samples were also collected at a flow rate of 1.7 liters per minute. In addition to determining the total mass concentration of the aerosol in the environment, a representative number of the total dust samples collected were particle sized with a Model TA II Coulter Counter.

TREATMENT OF DATA

Empirical relationships between number concentration, in mppcf, and respirable mass concentration, in mg/m^3 , were derived from the comparative measurements for the respective minerals using the method of least squares. For each mineral, the best fit regression line relating the measurements, standard error of estimate, $S_{y/x}$, and correlation coefficient, r , were calculated. The standard error of estimate provides a quantitative measure of the variability of the data about the regression line and the correlation coefficient provides a measure of the degree of linearity between the respective variables (number and mass concentration).

Equivalent respirable mass concentration values derived from the empirical relationships for each of the minerals were compared to the equivalent mass concentration limits specified in the 1976 TLV Handbook. In addition, respirable mass concen-

tration equivalent values were calculated using the method given in the Handbook and the parameters required for that calculation; i.e., aerosol, density and mass median diameter (M'_g).

Data obtained from the Coulter Counter analysis of the total dust samples were used to characterize the size distributions of the aerosols sampled. Count-versus-size data were converted to mass-versus-size data mathematically for each aerosol. Cumulative mass-versus-size data were plotted on logarithmic-probability graph paper, and the mass median diameter (M'_g) and geometric standard deviation (σ_g) were determined using the graphic technique developed by Hatch and Choate.⁴ The count median diameter (M_g) was then determined using the relationship:

$$\text{Log } M_g = \text{Log } M'_g - 6.9078 \text{Log}^2 \sigma_g.$$

RESULTS AND DISCUSSION

Figures 1 through 5 graphically show the data for the comparative measurements obtained for the respective minerals, the regression lines relating the count and mass concentrations obtained and the standard error of estimate and correlation coefficient for each of the relationships derived. The data compiled on Table I are: the density of the respective aerosols; the recommended limits specified in the 1976 and 1986 TLV Handbooks; four count-to-mass ratios (R) derived from: (1) the recommended count and mass concentration limits specified in the Handbook; (2) the empirically derived regression equations; and, (3) and (4) the procedure given in the TLV Handbook using the M_g and M'_g values that were determined to be representative of the respective aerosols sampled.

A comparison (Table I) was made of the ratio (R) between the count and mass concentrations ($\text{mppcf}:\text{mg}/\text{m}^3$) recommended

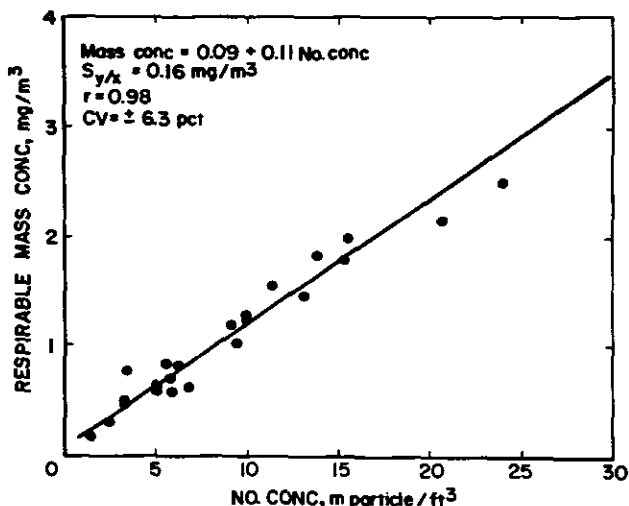

Figure 1. Comparison of dust concentrations obtained from midget impinger and respirable mass dust samples at two graphite processing operations.

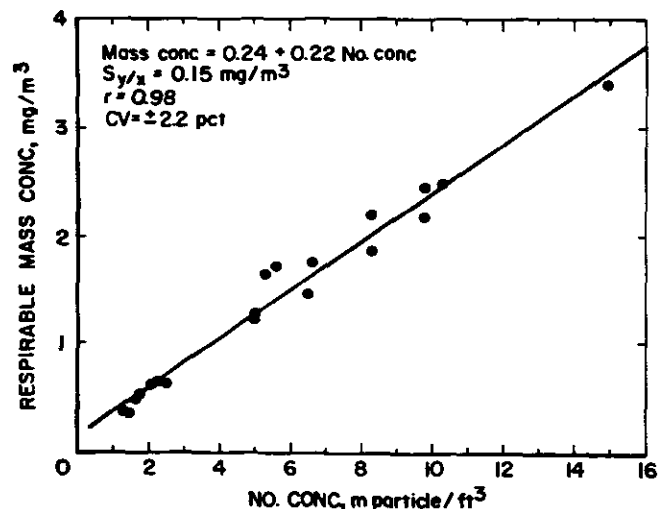

Figure 2. Comparison of dust concentrations obtained from midget impinger and respirable mass dust samples at two perlite processing operations.

in the TLV Handbook for the respective minerals and the ratios established from the empirical relationships and the calculation method using both the M'_g and M_g derived from the total dust samples. The comparison shows that only the empirically derived count to mass concentration ratio established for the mica and talc aerosols approximated the values recommended in the TLV Handbook. None of the ratios established from the calculation method agreed with the values recommended in the TLV Handbook or with the empirically derived values. It is apparent from the data that the M'_g or M_g established from a total dust sample measurement cannot be used to derive a factor for converting number concentration determinations to equivalent mass concentrations.

The method given in the TLV Handbook for calculating a factor based on the M'_g and density of the aerosol makes the

implicit assumption that the size distribution of the aerosols is similar; however, as the data show, the M'_g and geometric standard deviation differ significantly for aerosols found in the same type of mineral operations as well as those established for different mineral processing operations. It should also be recognized that when using the calculation method recommended in the TLV Handbook, a 15 percent difference in the diameter used to calculate an equivalency factor can result in a difference in the calculated equivalency factor of greater than 60 percent. This is due to the fact that conversion from a count to a mass concentration is a function of the cube of the particle diameter.

Review of the documentation, published in the 1976 TLV Handbook to arrive at, or substantiate, the value of "6" as the approximate factor used to obtain respirable mass concentration values equivalent to previously recommended number concentration values, showed that some of the supporting documentation is questionable. First, it is not clear which respirable dust criterion (that defined by the British Medical Research Council [BMRC] or by the ACGIH) was assumed to be followed by the respirable sampler when sampling the respirable fraction of the dust. The empirical relationship of 5.6 mppcf to 1 milligram per cubic meter of air was derived by Jacobson and Tomb,¹ from comparative measurements obtained with the midget impinger and the Isleworth Gravimetric Dust Sampler, Type 113A, an instrument that samples respirable dust according to the BMRC criteria. Mass concentration measurements obtained with a respirable mass sampler sampling respirable dust in accordance with the ACGIH criteria would be significantly lower. For coal mine dust, it has been shown⁵ that the ratio between mass concentrations determined with an instrument sampling respirable dust with respect to the BMRC criteria and an instrument sampling with respect to the ACGIH criteria is 1.38.

Another questionable item deals with the statement that "the mass median diameter of particles collected in impinger samplers and counted by the standard light-field technique and

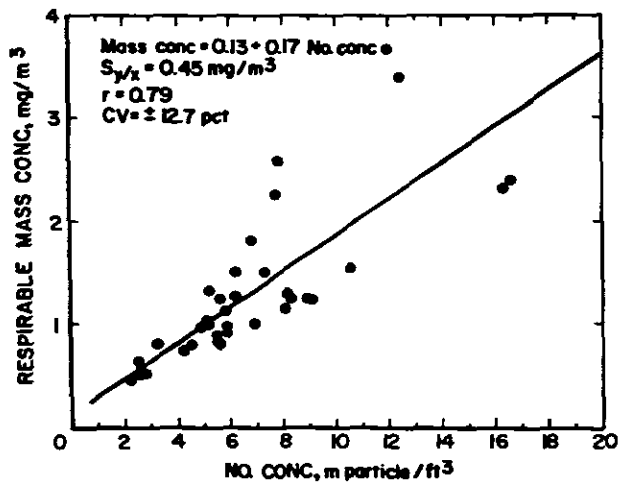

Figure 3. Comparison of dust concentrations obtained from midget impinger and respirable mass dust samples at two talc processing operations.

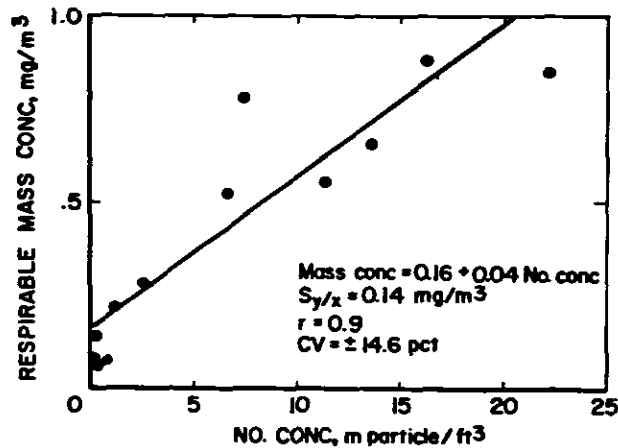

Figure 4. Comparison of dust concentrations obtained from midget impinger and respirable mass dust samples at two diatomaceous earth processing operations.

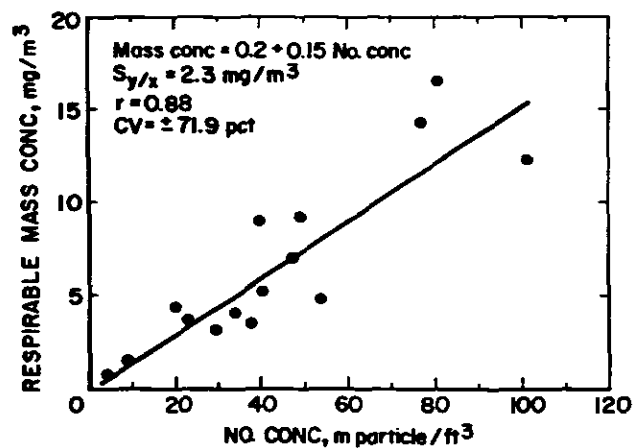

Figure 5. Comparison of dust concentrations obtained from midget impinger and respirable mass dust samples at two mica processing operations.

Table I
Comparison of Values (R) Obtained for Converting Count Concentration
Data to Equivalent Mass Concentration Data

Aerosol	Density gm/cm ³	Recommended TLV		R (mppcf/mg/m ³)				Aerosol Parameters		
		Count, mppcf	Mass mg/m ³	TLV	Emp	Calc. (M _g)	Calc. (M' _g)	M _g	M' _g	σ _g
Graphite I	1.76	15	2.5(1)	6	9.8	-	1.46	0.07	2.76	3.16
Graphite II					8.8	-	0.54	0.02	3.84	4.65
Perlite I	2.30	30	5 (1)	6	4.4	260	0.05	0.45	7.57	2.64
Perlite II			10 (2)		3.2	0.15	0.004	5.36	18.56	1.92
Talc I	2.75	20	3 (1)	6.6	5.5	28	0.32	0.89	3.95	2.01
Talc II			2 (3)	10	5.3	660	0.05	0.31	7.49	2.80
Diatomaceous Earth	2.20	20	1.5(1) 10 (2)	13	21.7	45	0.05	0.82	7.98	2.38
Mica	2.80	20	3	6.6	6.6	116	0.05	0.55	7.50	2.55

M_g = Count Median Diameter.

M'_g = Mass Median Diameter.

σ_g = Geometric Standard Deviation.

Emp = R Derived from Empirical Relationship.

Calc. (M_g) = R Calculated Using Count Median Diameter.

Calc. (M'_g) = R Calculated Using Mass Median Diameter.

(1) Respirable Dust Concentration Based on 1976 TLV Handbook.

(2) Total Dust Concentration Based on 1986-87 TLV Handbook.

(3) Respirable Dust Concentration Based on 1986-87 TLV Handbook.

Table II
Particle Size Distribution Parameters Derived from
the 1 to 10 Micrometers Fraction of the Aerosols

Aerosol	Aerosol Parameters			R (mppcf/mg/m ³)	
	M _g	M' _g	σ _g	Calc. (M _g)	Calc. (M' _g)
Graphite I	0.52	2.79	2.11	506	1.41
Graphite II	0.36	3.52	2.39	658	0.70
Perlite I	1.15	4.67	1.98	15.4	0.24
Perlite II	1.86	6.81	1.93	3.65	0.08
Talc I	1.31	3.42	1.76	8.74	0.49
Talc II	1.17	1.22	1.13	12.3	0.25
Diatomaceous Earth	1.97	5.14	1.76	3.21	0.18
Mica	1.42	4.61	1.87	6.60	0.20

M_g = Count Median Diameter.

M'_g = Mass Median Diameter.

σ_g = Geometric Standard Deviation.

Calc. (M_g) = R Calculated Using Count Median Diameter.

Calc. (M'_g) = R Calculated Using Mass Median Diameter.

collected in a respirable sampler is approximately $1.5 \mu\text{m}$." From the size distribution data obtained from the analysis of total dust samples in the size interval from 1 to 10 micrometers (Table II), and from comparing size distribution data from the Coulter Counter analysis of comparative total dust samples and impinger samples collected during these studies, it would appear that $1.5 \mu\text{m}$ would be more representative of the M_g than the M'_g . This is also supported by data obtained by Cooper⁶ in the Public Health Service's study of the diatomaceous earth industry. It is also highly unlikely that the M'_g of the particles collected in the impinger sample would be the same as the M'_g of the particles collected in the respirable dust sampler because of the nonuniform selection process of the particle classifier on the respirable dust sampler.

The last questionable item has to do with the diameter used in the calculation method to calculate an equivalent mass concentration. The example specifies using the M'_g . It appears from the presentation and definition of various diameters presented by Reist,⁷ that the diameter which should be used is the diameter of average mass; which is defined as representing the diameter of a particle whose mass times the number of particles per unit volume is equal to the total mass per unit volume of the aerosol. Although by definition this would appear to theoretically be the diameter to use, the recommended limits also could not be obtained when this diameter was used in the calculation method.

Based on the review of the documentation in the TLV Handbook and the relationships derived from comparative measurements obtained with the midjet impinger and the personal respirable dust sampler, it is concluded that: (1) "6" is not a factor that should be universally used to convert number concentration data obtained from the analysis of midjet impinger samples using light-field microscopic techniques to equivalent mass concentration data, (2) because of the variability that occurs in the size distributions of the aerosols sampled (even in the 1 to 10 micrometer size fraction), it is unlikely that a single parameter characterizing an aerosol can be used to calculate an equivalent mass concentration; and (3) comparative measurements should be used to derive the necessary factors for converting count concentration to equivalent mass concentration data.

SUMMARY

The validity of respirable mass concentration limits for mineral dusts recommended in the 1976 and 1986-87 ACGIH Threshold Limit Value Handbook as equivalent to previous-

ly recommended number concentration limits was investigated. The investigation consisted of reviewing the documentation in the 1976 TLV Handbook that was used to support the respirable mass concentration limits recommended; deriving empirical relationships from comparative measurement obtained with a midjet impinger and respirable personal dust sampler at industrial operations processing graphite (natural), perlite, talc, diatomaceous earth and mica; and comparing equivalent respirable mass concentration measurements obtained from the derived empirical relationships to those recommended in the TLV Handbook.

It was concluded from the investigation conducted that the general relationship, $6 \text{ mppcf} = 1 \text{ mg/m}^3$, used to convert particle count concentration data to respirable mass concentration data was not valid. This conclusion was based on:

1. Equivalent mass concentrations established from the empirical relationships derived from comparative impinger and respirable samples did not always agree with those recommended in the TLV Handbook.
2. The rationale supporting the $6 \text{ mppcf} = 1 \text{ mg/m}^3$ relationship was questionable and could not be confirmed using data collected during this investigation.

Because there was a significant difference in the empirical relationships derived between count and respirable mass concentration determinations and attempts to mathematically calculate equivalent mass concentrations were unsuccessful, equivalent respirable mass concentration limits should be empirically derived using comparative measurements obtained in the aerosol of interest.

REFERENCES

1. Jacobson, M., Tomb, T.F.: Relationships Between Gravimetric Respirable Dust Concentration and Midjet Impinger Number Concentration. *Am. Ind. Hyg. Assoc. J.* 28:554 (1967).
2. Dunmore, J.H., Hamilton, R.J., Smith, D.S.G.: An Instrument for the Sampling of Respirable Dust for Subsequent Gravimetric Assessment. *J. Sci. Instr.* 41:669 (1964).
3. Anderson, F.G.: A Technique for Counting and Sizing Dust Samples with a Microprojector. *Am. Ind. Hyg. Assoc. J.* 23:330 (1962).
4. Hatch, T.H., Choate, S.P.: Statistical Description of the Size and Properties of Nonuniform Particulate Substances. *J. Franklin Inst.* (1929).
5. Tomb, T.F., et al.: Comparison of Respirable Dust Concentration Measured with MRE and Modified Personal Gravimetric Sampling Equipment. *Bureau of Mines RI 7772* (1973).
6. Cooper, W.C., Crally, L.J., et al.: Pneumoconiosis in Diatomite Mining and Processing. *PHS Pub. No. 601*, G/SGPO, Wash. D. C. (1958).
7. Reist, P.C.: Introduction to Aerosol Science. *Micromillan Pub. Co.*, Chapter 2, (1984).

SIZE DISTRIBUTION OF RESPIRABLE COAL MINE DUST

P.C. THAKUR • L.D. Taylor • J.B. Riester

Consolidation Coal Company, Morgantown, WV, USA

ABSTRACT

The 1969 Coal Mine Health and Safety Act set a threshold limit value for respirable dust in U.S coal mines at 2.0 mg/m^3 . The upper limit of the respirable dust size is 10 micrometers on a unit density basis. Although the lower limit is not defined, it can be measured to 0.1 micrometer with modern instruments. The amount of dust associated with each size interval from 0.1 to 10 micrometer represents the size distribution of respirable coal mine dust. The size distribution is generally a function of the generation process, which in the case of mechanical grinding, includes the breaking mechanism and more importantly the properties of the material being mined. Coal mine dust is actually an aggregate of fine coal particles, roof and floor dust, rock dust, diesel particulates (where diesel engines are in use), and fluid particles such as water and oil particles. Therefore, it is not surprising that the size distribution varies from coal seam to coal seam and sometimes even from mine to mine in the same coal seam.

The paper reviews major past works and develops a size distribution function most suited for fine respirable coal mine dust. Also investigated are changes in the distribution parameters of the composite dust when two or more dust clouds are mixed. Results of both laboratory and field studies are presented to confirm that coal rank and depth of the coal seam significantly influence the distribution parameters.

No Paper provided.

PERFORMANCE OF RESPIRABLE DUST SAMPLING SYSTEMS IN UNDERGROUND COAL MINES

C.Y. HWANG, Ph.D. • G.W. Bonnell, B.Sc. • G.R. Corbett •
D.A. Young • C.H. MacNeil

Canada Centre for Mineral and Energy Technology, Coal Research Laboratories,
Sydney, Nova Scotia, Canada

ABSTRACT

Our long-term research on respirable coal mine dust emphasizes the suppression of dust sources for the prevention of coal workers' pneumoconiosis. As part of this research, concentration measurements were made by using various samplers in 2 Canadian underground coal mines. The dust sampling in longwalls and development headings included fixed position and personal sampling. The airflow rates of sampling pumps deviated on average 1.4% from initially calibrated values. The weight of a 37 mm diameter membrane filter changed as much as 0.05 mg due to humidity.

The relationships specific to mine site and mining method, between concentrations measured by fixed position sampling using different samplers and those determined by Casella gravimetric samplers (CGS-113A) are described. Respirable dust concentrations determined by samplers consisting of DuPont (2500A) or Gilian (HFS) pumps with Casella cyclones approached that by the CGS. The samplers made of MSA (F-F) pumps with Dorr-Oliver cyclones measured respirable values on an average at 45.5% for Mine A and 58.5% for Mine B of the values determined by the CGS. The respirable dust concentration ratio of Anderson eight-stage cascade impactors to the CGS markedly varies as a non-linear function of dust level. The shift-length average concentrations determined by a light-scattering system SIMSLIN II were lower than those by the CGS. A Hund's dust monitor TM-DATA measured the concentrations nearly equal to that by the SIMSLIN II. The differences in instantaneous dust level between the 2 systems are presented for coal cutting time.

Precision and practical aspects of coal mine dust measurements and implications of assessing the miner's health risk due to prolonged dust exposure are discussed.

INTRODUCTION

The etiology of coal workers' pneumoconiosis has not yet been fully understood. The prevention of this occupational disease thus depends upon elimination of airborne coal mine dust to which miners are exposed. The objectives of the Canada Centre for Mineral and Energy Technology (CANMET) respirable dust research program are directed to the suppression of the respirable dust in coal mine environments.

Numerous dust sampling systems or dust monitors are available and have been used for dust measurement by the mining industry. For long-term evaluation of dust exposure and for assessment of effectiveness of a dust suppression measure, it is essential that the measurements made by different samplers be reproducible and comparable. This paper describes part of CANMET's dust research program which evaluated the performance of various types of dust sampling systems tested in two Canadian underground coal mines covering three periods of time, i.e. December 1984–March 1985; December 1985–June 1986; and January–February 1987.

INSTRUMENTS AND METHODOLOGY

Gravimetric Samplers

A Casella Gravimetric Sampler (CGS) Type 113A employs a horizontal elutriator to remove non-respirable sized particles by gravitational settlement. A personal sampling system (which can also be used as a fixed position sampler) consists of an electronically flow-controlled pump and a cyclone that selects dust particles by centrifugal action. A cascade impactor is another particle size selector used in a sampler based on inertial impaction. The Anderson (Marple) Cascade Impactor Model 298 has eight stages of dust collection.

Light-Scattering Real-Time Dust Monitors

Two real-time dust monitors were used: a SIMSLIN II and a Hund's TM-DATA. The SIMSLIN II employs a horizontal elutriator as a dust particle size selector. Its laser light source has a wavelength of 0.904 μm and the scattered light by dust particles is detected between 12–20 degrees to the forward direction. The TM-DATA has, as its light source, an infrared light beam with a wavelength of 0.950 μm . This

instrument measures the light scattered by dust particles at an angle of 70 degrees to the direction of the beam. Although it does not employ a horizontal elutriator the use of this scattering angle and the specific wavelength permits the measurement of respirable dust concentration. Both the SIMSLIN II and the TM-DATA are portable and thus useful in evaluating real-time dust levels for various coal winning activities. Their output signals may be fed to a computer for analysis, comparison, and graphical presentation.

Field Dust Sampling and Performance Tests

Both fixed position and personal sampling were used in CANMET's dust sampling program. Personal dust sampling, either face-time or portal-to-portal, directly provides information on individual dust exposure. For the fixed position sampling, specific locations were chosen for shift-length sampling in longwall sections and development headings of two underground coal mines (Figure 1). Station D, which is in the tailgate 70 m from the faceline, is a statutory dust control point of an advancing or a retreating longwall. It was this location where various samplers or dust monitors were tested side-by-side at breathing zone height. Similar tests were also carried out at Station Q which is 100 m from a development heading (Figure 1). The results of performance test work which will be described in this paper were obtained by fixed position sampling in five longwall sections of Mine A, in two longwall sections of Mine B, and in one deep development heading of Mine B during the three periods of time as indicated previously.

RESULTS

Sampling Airflow Rates

The pump of each sampler used with a specific type of filter was calibrated at CANMET's Cape Breton Coal Research Laboratory prior to sampling. Following a shift-length survey, the flow rate of this pump was again determined. The absolute differences or deviations between the initial and final flow rates were calculated and expressed as percentages of the initial flow rates. The mean deviations determined in various mine sites appeared different for each pump type used with the samplers. With DuPont pumps in the walls of both mines, the mean deviation varied from 0.7 to 1.0%, while with Gilian pumps in Mine B the mean deviation varied from 1.2 to 1.4%. The mean deviation of CGS was higher (2.1%) in Mine A as compared with those evaluated in Mine B for wall sections (0.9%) and for a development heading (1.0%). The individual deviation in the flow rate ranged from 0 to 6.2% in the two mines for CGS; for all the personal gravimetric samplers, the deviation ranged from 0 to 7.1% in the mines.

Filters as Dust Collection Media

Membrane filters react by weight change in various environmental conditions. Millipore membrane filters (made of mixed cellulose acetate and nitrate) gain weight when the surrounding humidity increases. The enclosed weighing chamber of an electro-microbalance (CAHN C-29) can be a different environment for a membrane filter as compared to the laboratory environment. Therefore the time during which a

filter is kept in the chamber before a reading is made, becomes an important factor when weighing filters. We make use of an air conditioner and blanks to overcome this problem. Other filters such as Nuclepore polycarbonate and glass fibre filters showed negligible weight loss. An ionizing unit (Staticmaster) was also used to eliminate static charges on all the filters before weighing.

Variability of Concentration Measurement made by Casella Gravimetric Samplers Type 113A

Two to three sets of the Casella Gravimetric Samplers (CGS) were used for each dust survey. The standard deviation and percent variation expressed as a percentage of the average of concentrations measured by the CGS, were evaluated for each sampling shift and are shown in Figure 2, in which the abscissa represents the concentration values normalized to the maximum average concentration determined during a specific shift. This variation in standard deviation (Figure 2a) from 0.01 mg/m³ to 0.34 mg/m³ appears to be fixed regardless of the normalized concentration and thus indicates a systematic error of measurement as high as 0.34 mg/m³. The percent variation (Figure 2b) varies from 0.1% at the normalized concentration of 0.61 to 10.3% at 0.23. For Mine A, this variation appears to decrease with increasing concentration but for Mine B, it increases slightly as the concentration increases.

Relative Respirable Dust Concentrations Determined by Personal Gravimetric Samplers

At the dust control points of the wall sections of Mine A and Mine B, three to five sets of personal gravimetric samplers (one set with the Dorr-Oliver cyclone and the others with Casella or Rotheroe/Mitchell cyclones) were installed side-by-side with CGS. The standard deviation and percent variation obtained for the samplers using the Casella cyclones are shown in Figure 3. For comparison purposes those evaluated in a dust chamber by using 12 sets of the personal samplers are also included. The variation in standard deviation (Figure 3a) from 0.03 mg/m³ to 0.45 mg/m³ in the two mines appears to be fixed regardless of the normalized CGS concentration. The result of testing in the dust chamber (Figure 3a) has shown a systematic error of measurement as high as 0.44 mg/m³ in the normalized concentration range of 0.24 to 0.65. A high standard deviation value (0.56 mg/m³) has been observed in the dust chamber beyond the concentration range of interest. Regardless of the mine type, the percent variation decreases from 9.2% to 1.1% in the concentration range of 0.2 to 1.0 (Figure 3b). Similar to the variations of CGS, the percent variations of the personal samplers in Mine B are less than those determined in Mine A. The overall decreasing trend of the percent variation observed in the two mines has been verified by the results obtained in the dust chamber. Regardless of mine dust concentration, the average of percent variations (1.9%) evaluated in Mine B was less than the average (5.3%) in Mine A.

For each individual sampling system, the ratio of respirable dust concentration measured by this sampler during a sampling shift to the average of concentrations determined by CGS in the same shift was calculated. The ratios were grouped by sampler type for the two mines in Table I. On the longwalls

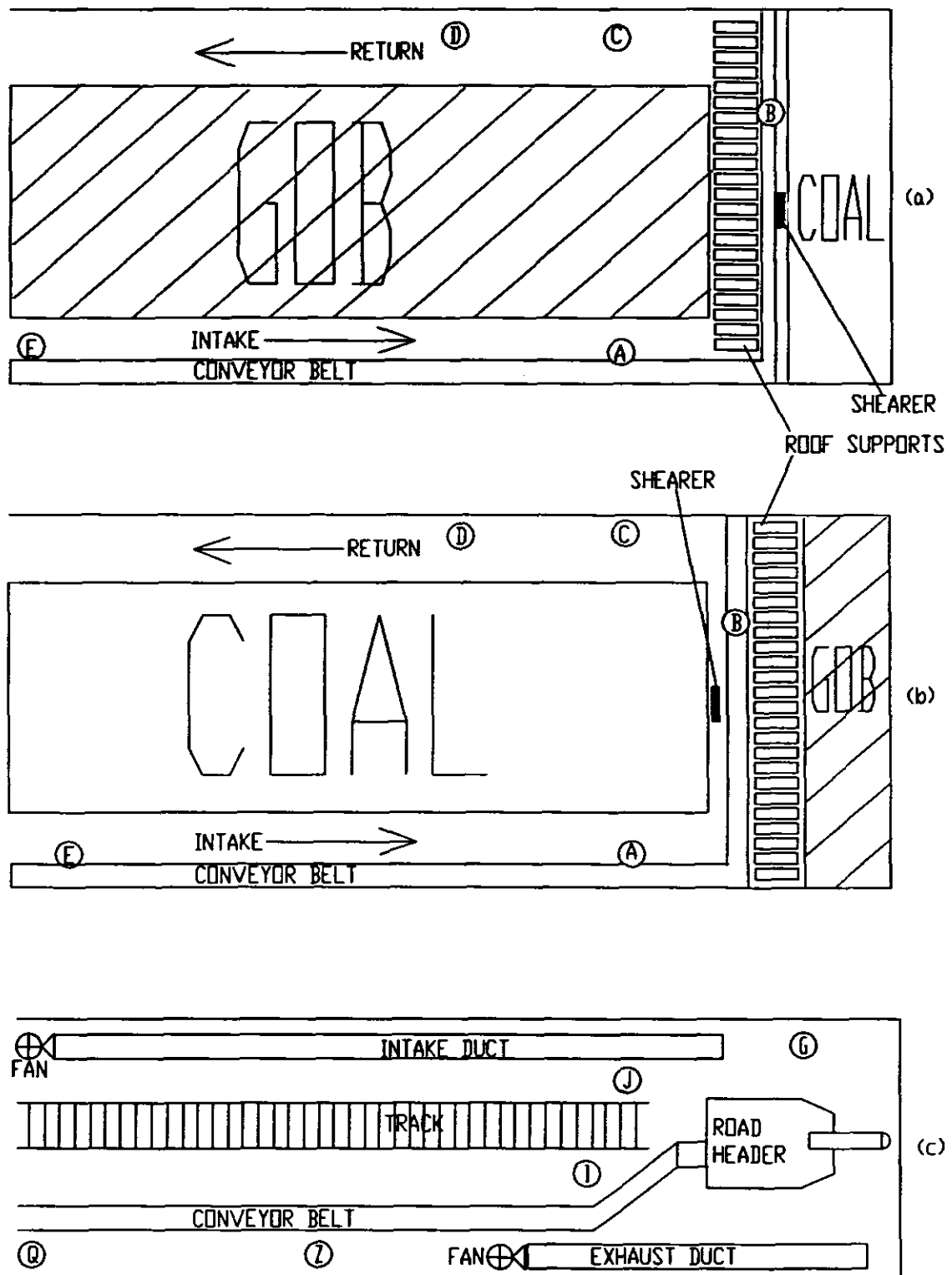

Figure 1. Fixed position sampling locations in (a) an advancing longwall section, in (b) a retreating longwall section and (c) a development heading.

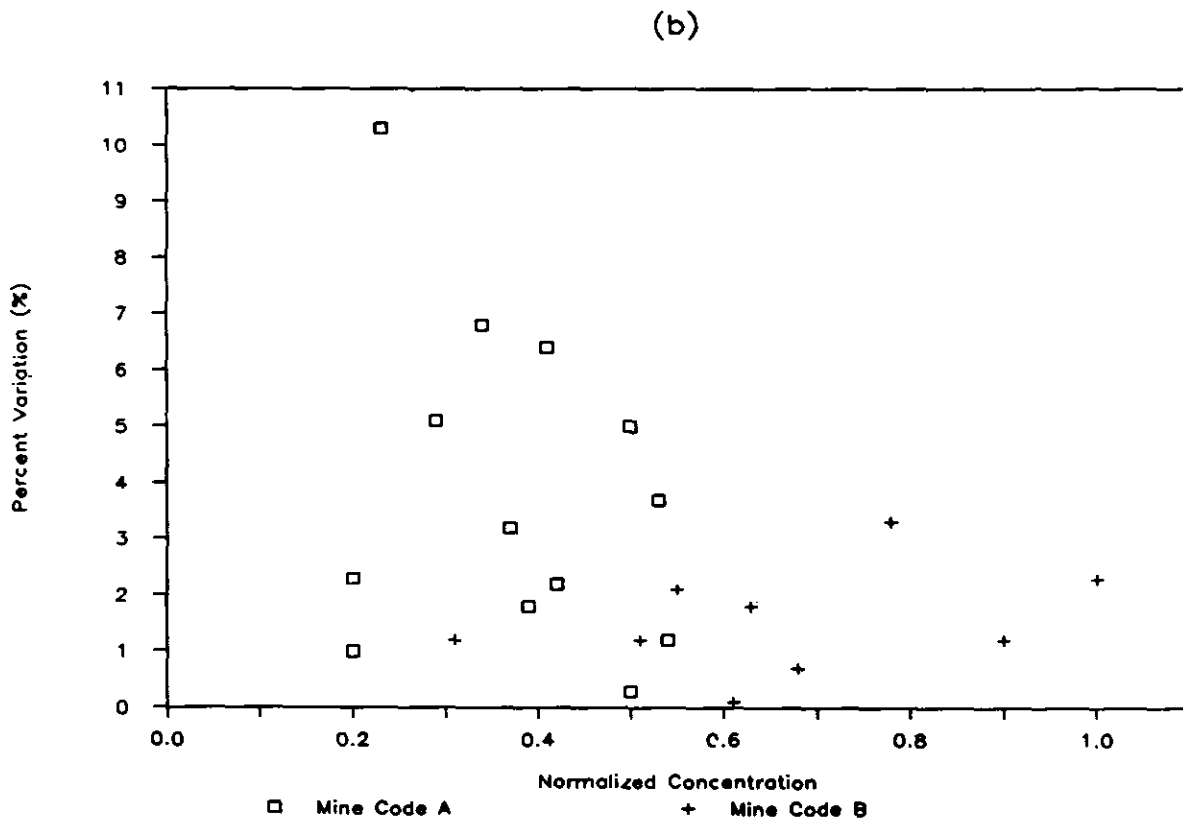
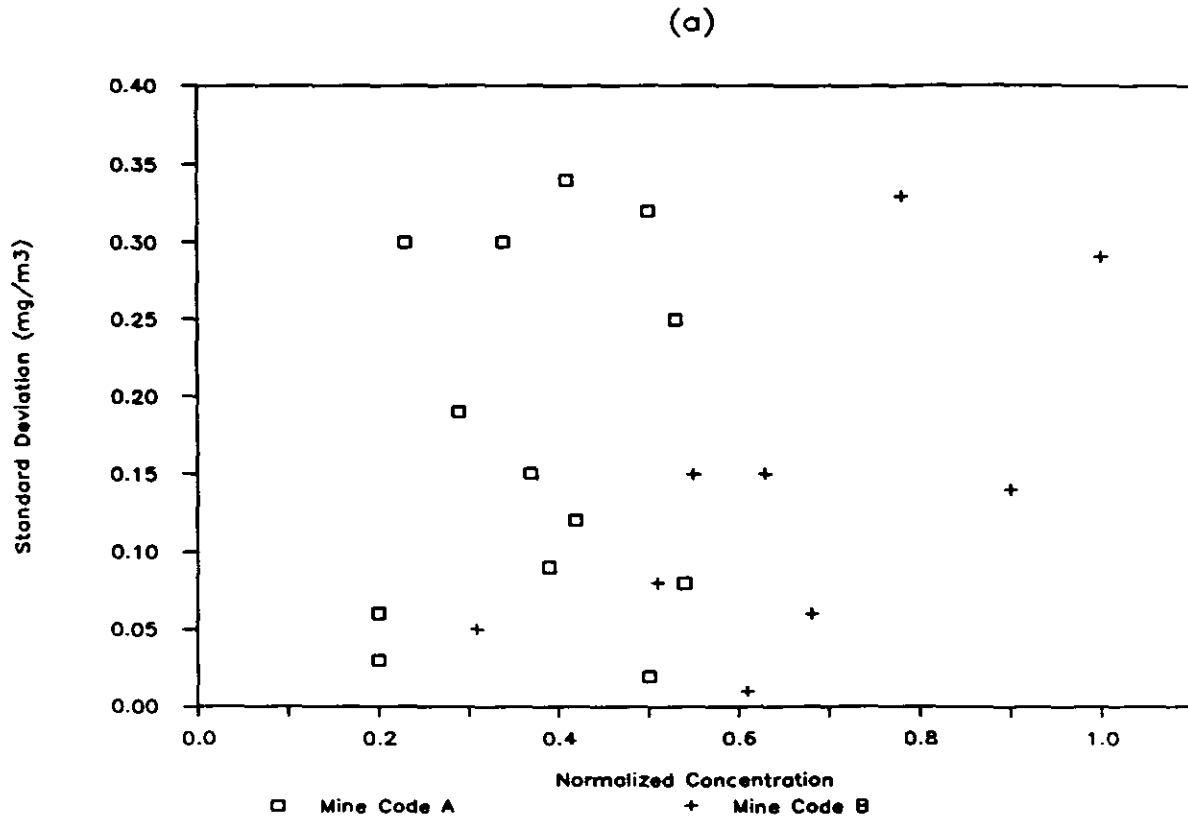

Figure 2. (a) standard deviation and (b) percent variation of concentrations measured at longwalls by Casella Gravimetric Samplers 113A for each field test in Mine A and Mine B.

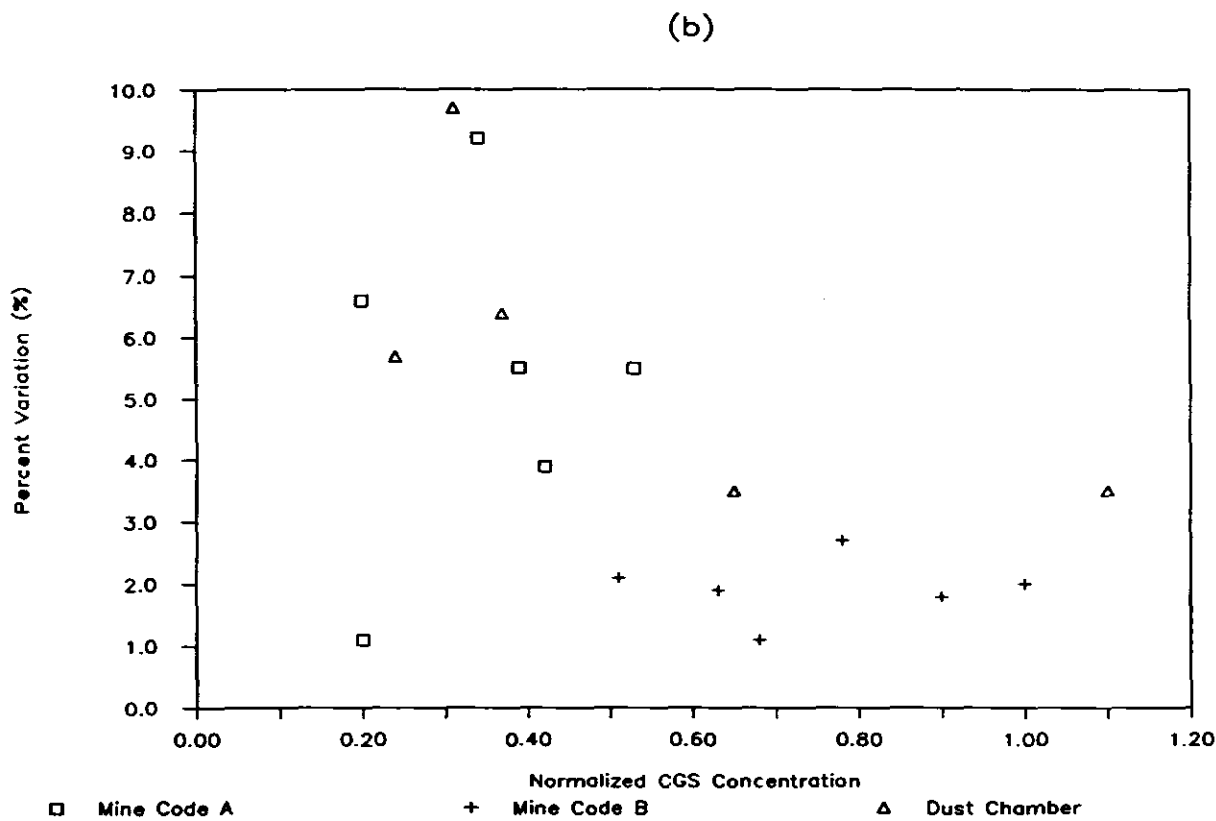
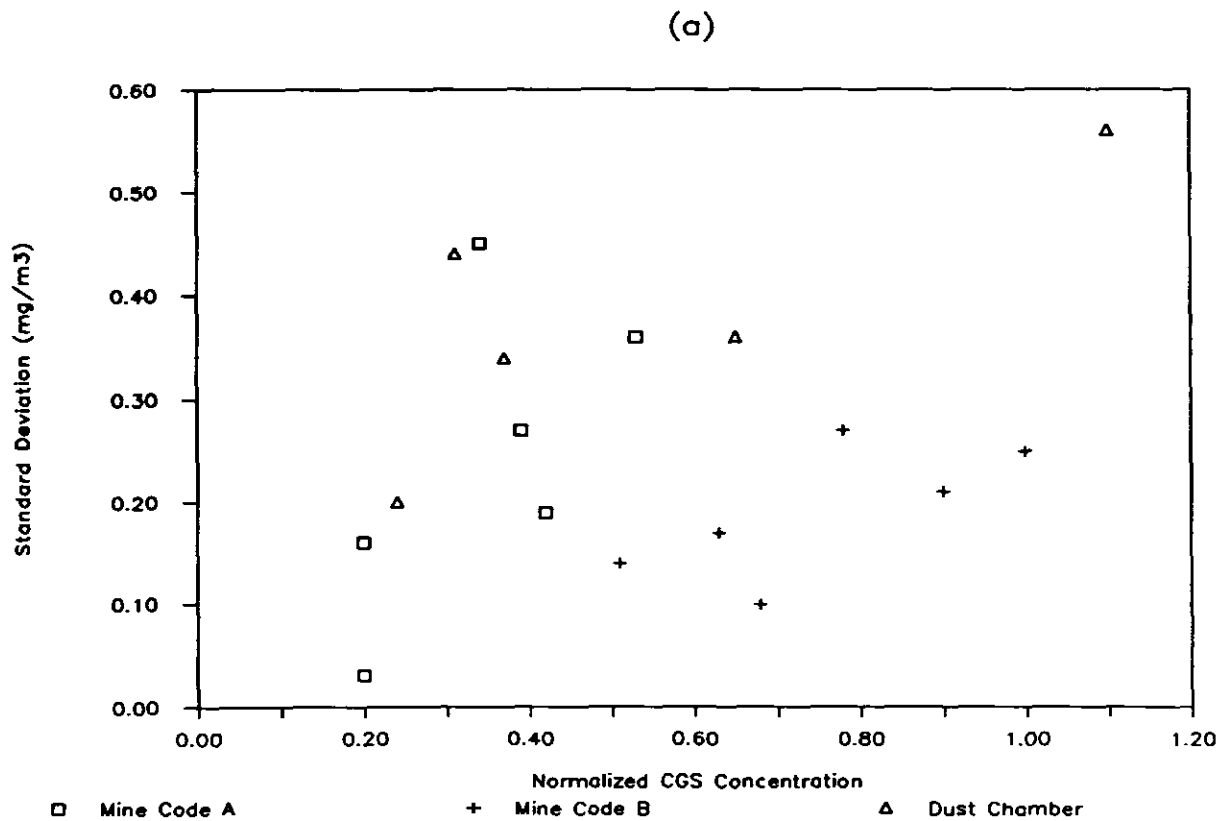

Figure 3. (a) standard deviation and (b) percent variation of Personal Gravimetric Samplers with Casella cyclones tested in Mine A, in Mine B and in a dust chamber.

Table I
Average of Ratios of Concentration Measured by a Personal Sampling System
to the Averaged Concentration Determined by the
Casella Gravimetric Samples (CGS) 113A

Sampling System	Mine A (5 Walls)		Mine B (2 Walls)		Mine B (1 Development Heading)	
	Average Ratio	Standard Deviation	Average Ratio	Standard Deviation	Average Ratio	Standard Deviation
DCM ¹	0.89 (12) ⁺	0.11	1.01 (5)	0.03	1.09 (2)	0.15
DCG ²	0.89 (8)	0.08	1.01 (7)	0.04	1.11 (2)	0.06
GCM ³	0.99 (4)	0.06	1.05 (4)	0.04	-	-
GCG ⁴	0.96 (4)	0.04	1.04 (6)	0.04	1.11 (2)	0.01
DCN ⁵	0.92 (4)	0.06	1.05 (4)	0.04	-	-
MCM ⁶	0.94 (5)	0.12	-	-	-	-
MCG ⁷	0.89 (2)	0.13	-	-	-	-
MNP ⁸	0.45 (9)	0.03	0.58 (6)	0.04	0.60 (2)	0.09

¹DCM = DuPont Pump + Casella Cyclone (or Rotheroe/Mitchell Cyclone) + Millipore (MP) Mixed Cellulose Acetate and Nitrate Membrane Filter (37 mm dia., 0.8 μ m pore).

²DCG = DuPont Pump + Casella Cyclone + Glass Fibre (GF) Filter (37 mm dia., 1.5 μ m pore).

³GCM = Gilian Pump + Casella Cyclone + MP Membrane Filter.

⁴GCG = Gilian Pump + Casella Cyclone + GF Filter.

⁵DCN = DuPont Pump + Casella Cyclone + Nuclepore Polycarbonate Membrane Filter (37 mm dia., 0.8 μ m pore).

⁶MCM = MSA Pump + Casella Cyclone + MP Membrane Filter.

⁷MCG = MSA Pump + Casella Cyclone + GF Filter.

⁸MNP = MSA Pump + Nylon Cyclone + PVC Filter (37 mm dia., 0.8 μ m pore).

⁺Number of ratios averaged for each sampler type is shown in parentheses.

of the two mines, the averaged ratio appeared to be different from one sampler type to the other. The ratios evaluated for Mine A were less than those determined for Mine B. The average ratio obtained in the development heading of Mine B had greater values than the two walls of this mine had for four types of sampler. The average ratios determined by the samplers with the nylon cyclones had approximately one-half the values of those evaluated by the samplers with the Casella cyclones both in Mine A and in Mine B.

Measurement of Respirable Dust Concentration and Particle Size Distribution by Marple Personal Cascade Impactors Model 298

Two Marple (Anderson) cascade impactors, M1 and M2, were employed in two wall sections of Mine A and in one wall section and a development heading of Mine B. To evaluate respirable dust concentration, the mass determined for Stages No. 5 through No. 8 and for the backup filter were summed as the respirable portion which represented particles less than 6 μ m in aerodynamic equivalent diameter. The relative respirable dust concentrations determined in the wall sections

of the two mines by the impactors are plotted in Figure 4, versus the average CGS concentration normalized to the maximum CGS concentration value. The relative concentration ranged from 0.81 to 1.24 as determined by the impactor M1, and ranged from 0.69 to 1.18 as determined by the impactor M2 in the normalized CGS concentration range of 0.26 to 1.0. The relative concentrations appear to decrease non-linearly with increasing mine dust levels determined by CGS. For M1 and M2, the size distributions (expressed as percent by mass) obtained from four tests in the wall sections of Mine A, six tests in the wall section of Mine B, and two tests in the development heading of Mine B were averaged and shown in Figure 5. There are larger proportions of particles with sizes greater than 6 μ m (expressed in geometric mean diameter, G.M.D.) in Mine A as compared with the distributions obtained in Mine B. The size distributions obtained in the development heading had a greater proportion of particles with size less than 6 μ m as compared to those obtained in the wall section of Mine B or the wall sections of Mine A. It must be noted that in calculating a size distribution, the dust collected on the substrate of the first stage (with a G.M.D. of 32 μ m) and the backup filter was not used.

(a) Impactor M1

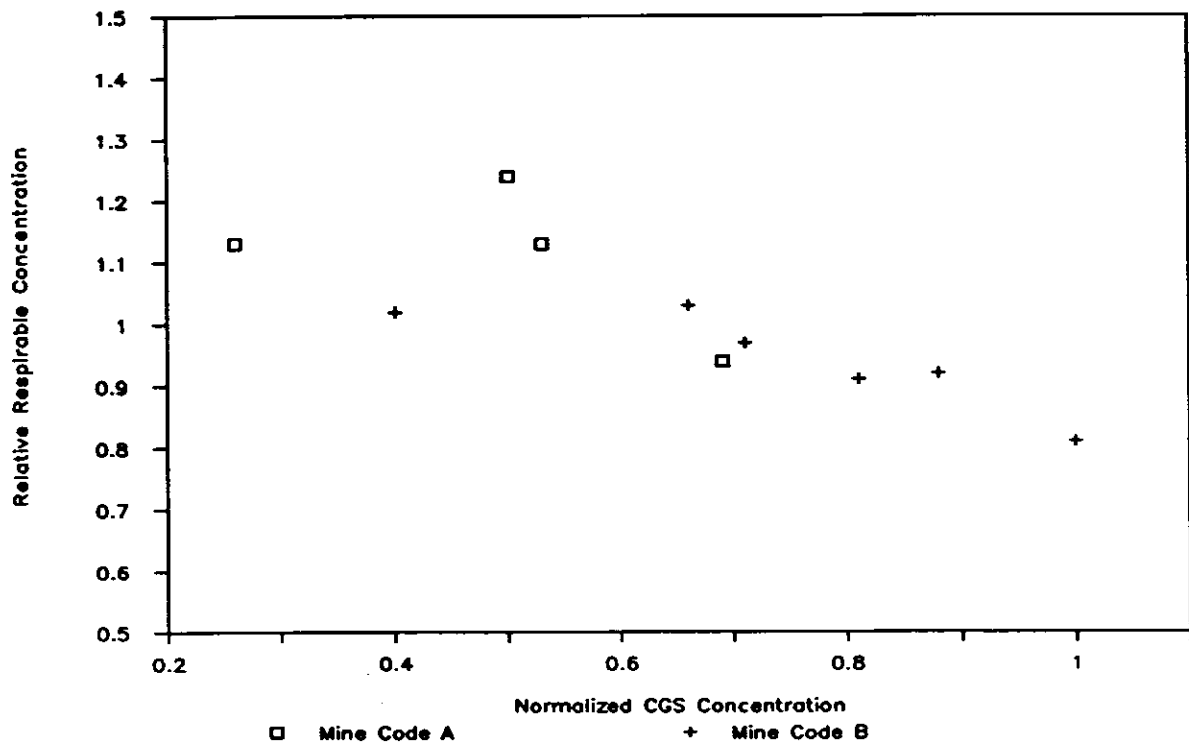

(b) Impactor M2

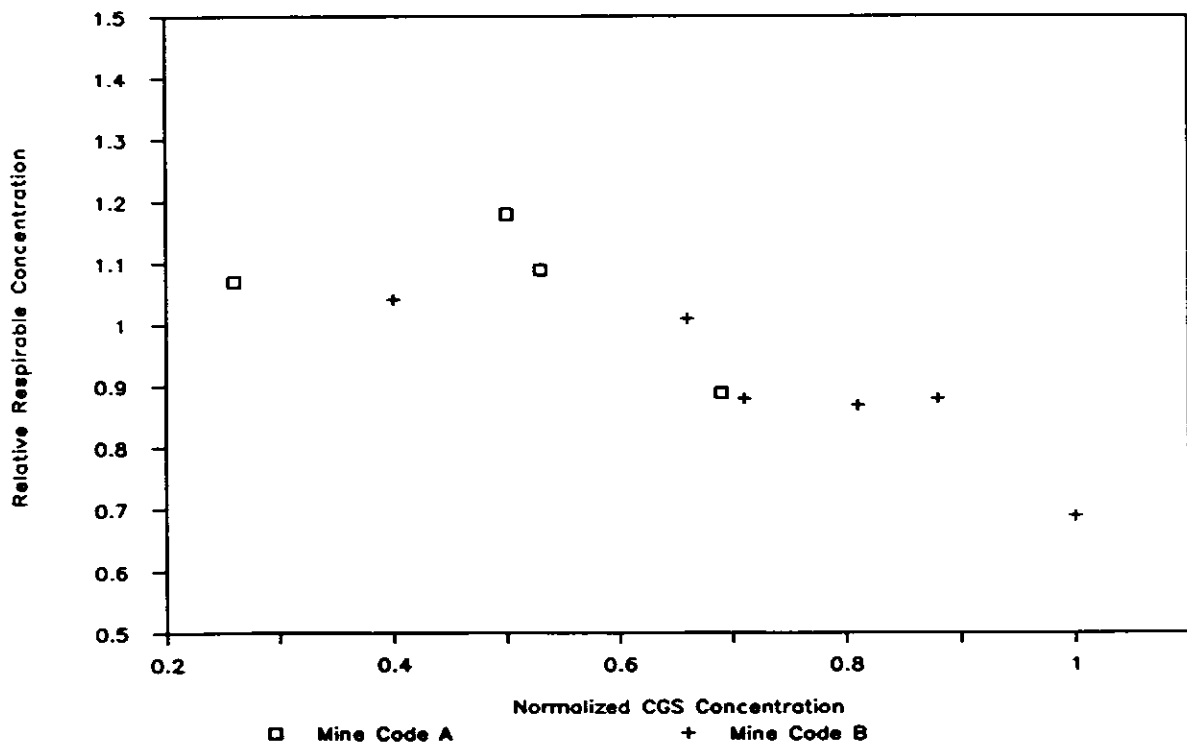
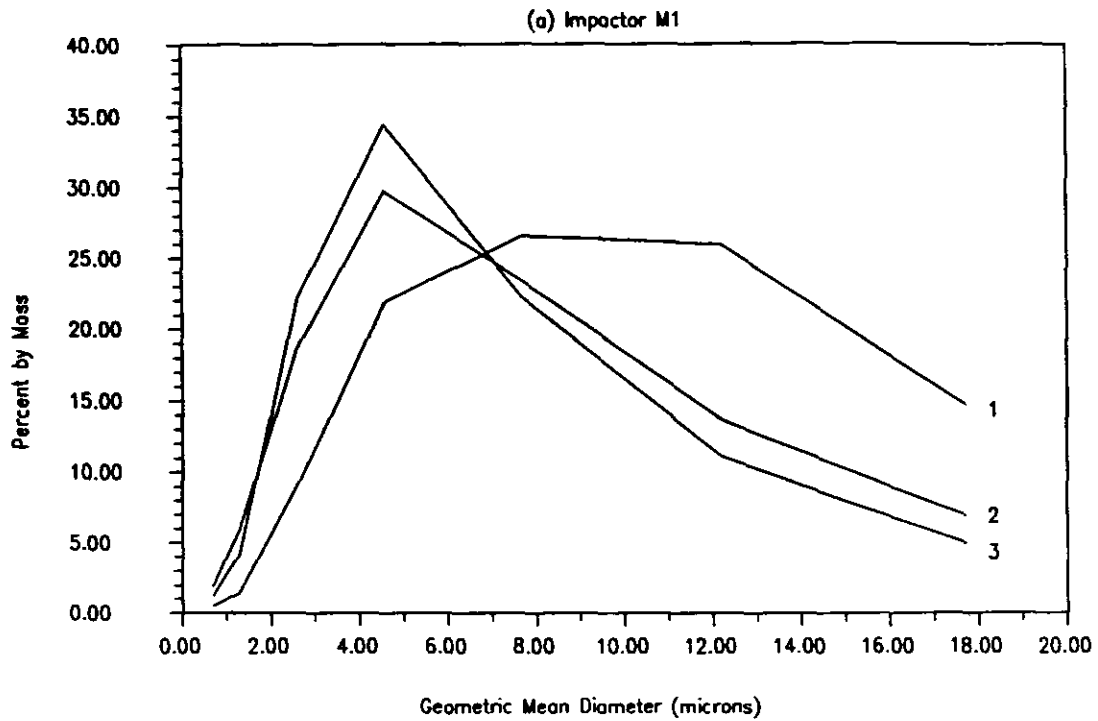
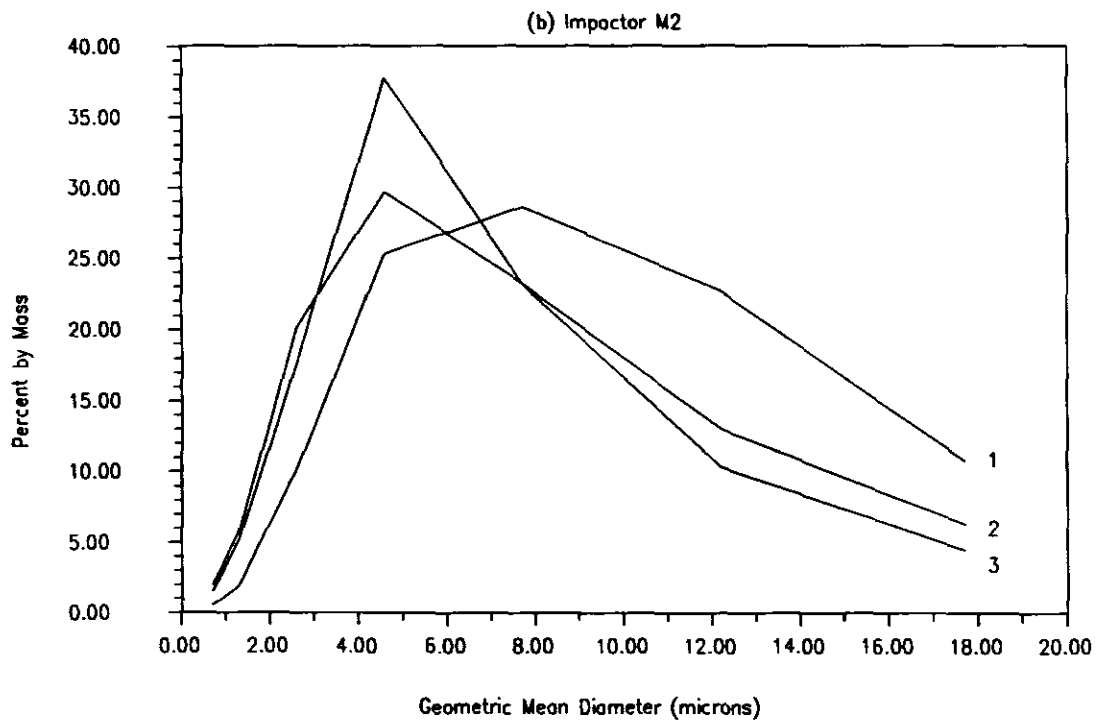

Figure 4. Relative respirable dust concentrations determined in Mine A and Mine B by the samplers (a) with the cascade impactor M1 and (b) with the cascade impactor M2.



1 Mine A (walls) 2 Mine B (wall) 3 Mine B (development heading)



1 Mine A (walls) 2 Mine B (wall) 3 Mine B (development heading)

Figure 5. Average size distributions of airborne dust measured by (a) impactor M1 and (b) impactor M2 in Mine A and Mine B.

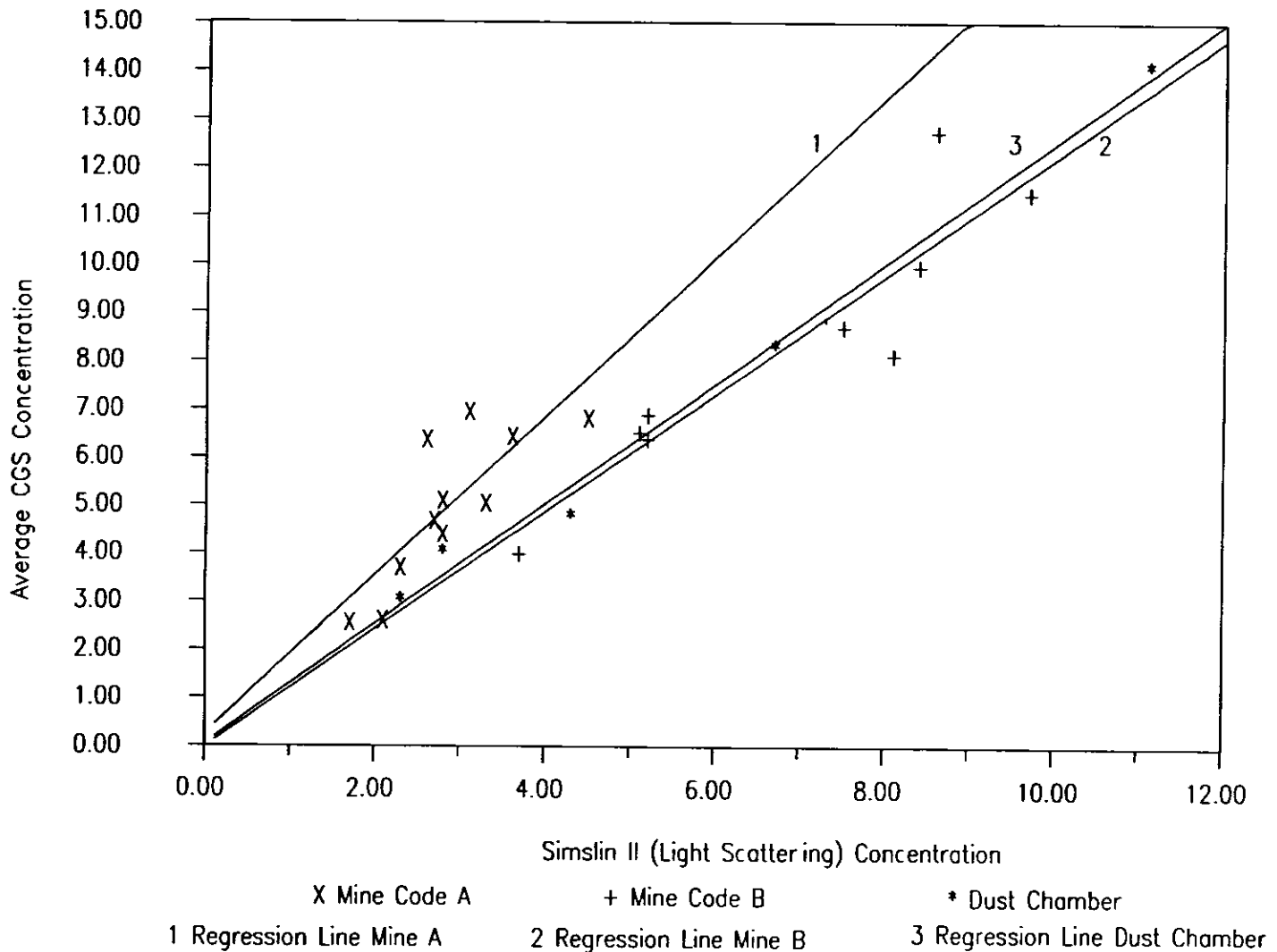

Figure 6. Linear relationships between the concentrations (in an arbitrary unit) determined by SIMSLIN II and by Casella Gravimetric Samplers (CGS) in Mine A, Mine B and in the dust chamber.

Measurements of Respirable Dust by Real-Time Dust Monitors

A factory-calibrated SIMSLIN II monitor was tested side-by-side with CGS at the control points of the longwalls of the two mines. The end of shift average concentrations determined by the SIMSLIN's light-scattering system were found to be less than the CGS concentration with an average concentration ratio 0.60 for Mine A and 0.81 for Mine B. The linear relationships between the SIMSLIN's concentration and those measured by CGS are depicted by Figure 6 for Mine A, Mine B, and the dust chamber. The regression line representing Mine A is markedly different from the line obtained in Mine B. The line derived from the tests in the dust chamber appears to be similar to the line representing Mine B.

Three shift-length tests have been carried out in Mine A in order to compare the dust concentrations determined by TM-

DATA with that determined by SIMSLIN II and by CGS. Table II shows the end-of-shift average concentration relative to the CGS concentration obtained in two wall sections. The relative concentrations determined at the wall section (coded WF) by the two monitors were almost identical, but in the test at the wall WE, the relative concentration by TM-DATA was greater than that measured by SIMSLIN II. Although there are some differences at the beginning of some coal cutting periods, the concentration recordings by the two monitors appear similar (Figure 7). When a shearer started coal cutting, TM-DATA recorded a concentration peak higher than the peak registered by SIMSLIN II; such a difference may characterize TM-DATA which does not employ an elutriator as a particle size selector. TM-DATA does not have a time delay due to the fact that it has no pump and consequently no internal tubing.

DISCUSSIONS

The measurement of respirable dust concentrations by gravimetric techniques is subject to variations in the sampling flow rate of pumps, the handling of filters, and in the filter weight change caused by humidity or static electrical charges. The sampling systems, if used for personal sampling instead of fixed position sampling, are subject to more variations due to the additional movements and impacts associated with mounting the devices on mobile miners. A Casella Gravimetric Sampler's flow rate may deviate as much as 6.2%. The flow rate deviation of a personal gravimetric sampler has a maximum value of 7.1%. The overall filter weight change has been as high as 0.34 mg for a change in laboratory relative humidity of 20%.

The precision of respirable dust concentration measurements by using one type of gravimetric sampler increases with increasing mine dust levels. For the Casella Gravimetric Samplers (CGS) and the personal samplers with Casella cyclones, the percent variation may take a value as low as 1% to 3% in mine locations with a dust level above 6 mg/m³; below 6 mg/m³ the variation could reach a value as high as 10%. Thus, any concentration value determined by a given type of gravimetric dust sampler relative to the CGS is subject to greater percentage errors when it is employed in a lower dust level. However, the results described in this paper indicate that such variability also depends to some extent on the mine type. Retreat longwall mining generates airborne dust mainly by the shearer's cutting and face support movement while advance longwall mining generates the dust by the coal cutting activity as well as various activities in the headgate and the tailgate. It has been shown that dust particle size distributions are different between the two mines. Furthermore, the two mines work different coal seams and thus the nature of the airborne dust particles (e.g. mineralogical composition) may vary from one mine to the other.

When a cascade impactor is used as the size selector for the measurement of respirable dust concentration, there is evidence that the measured relative concentration varies non-linearly with increasing mine dust level. This change in the relative respirable dust concentration has been explained elsewhere.¹ The linear relationships between the SIMSLIN's data and that obtained by the CGS in the two mines are different and thus indicate that the nature of the dust particles

in addition to size distribution may also play an important role in the differences resulting from the concentration measurements made by using a light-scattering technique.²

Errors introduced in the measurement of respirable dust concentration imply uncertainty in assessments of the risk of pulmonary diseases in miners. This problem becomes more serious if the concentrations measured in a limited number of sampling shifts are to be used retrospectively for the evaluation of occupational dust exposure of miners. The activities of mechanized long wall mining have resulted in marked variation in shift-averaged concentration measured from time to time at the same wall section. Most of the past health studies in relation to long-term dust exposure were based on the dust levels measured by the CGS samplers, which have varying degrees of precision when used in different mine sites or in dust clouds with different dust particle size distributions. If any other type of gravimetric dust sampler were chosen to measure dust levels for the purpose of indirect risk estimation, the magnitude of errors in the estimation would be greater than that based only on the CGS measurement. Although the dust concentration measurement by a light-scattering technique provides information on instantaneous and time-averaged dust levels, the measured values may not indicate precise mass concentrations for the stated reasons. Thus those measured values are less useful for an exposure assessment. However, a real-time dust monitor is useful to evaluate relative change in dust level within a short period of time in a production shift and for determining the effectiveness of a dust suppression technique.

The following is an example to illustrate the effect of respirable dust concentration measurements on the assessment of health risk of a miner. If a mean coalface concentration is 4 mg/m³ and if an overall error of 10% (i.e. ± 0.4 mg/m³) were introduced by concentration measurements, the probability that a miner with no pneumoconiosis (in the International Labour Organization category 0/0) is classified into the category 2/1 or higher after 35 years of dust exposure would be overestimated by 0.0096 or be underestimated by 0.0082.³

With sound knowledge of the relative performance of the various samplers described, we shall routinely use for fixed position and personal sampling, the gravimetric samplers

Table II
Shift-Length Side-by-Side Tests of TM-DATA
and SIMSLIN II in Two Longwalls of Mine A

Wall Code	Shift Code	Concentration Relative to the Average CGS Concentration	
		TM-DATA	SIMSLIN II
WF	#1	0.68	0.66
	#2	0.65	0.66
WE	#3	0.78	0.65

(a) Simslin II

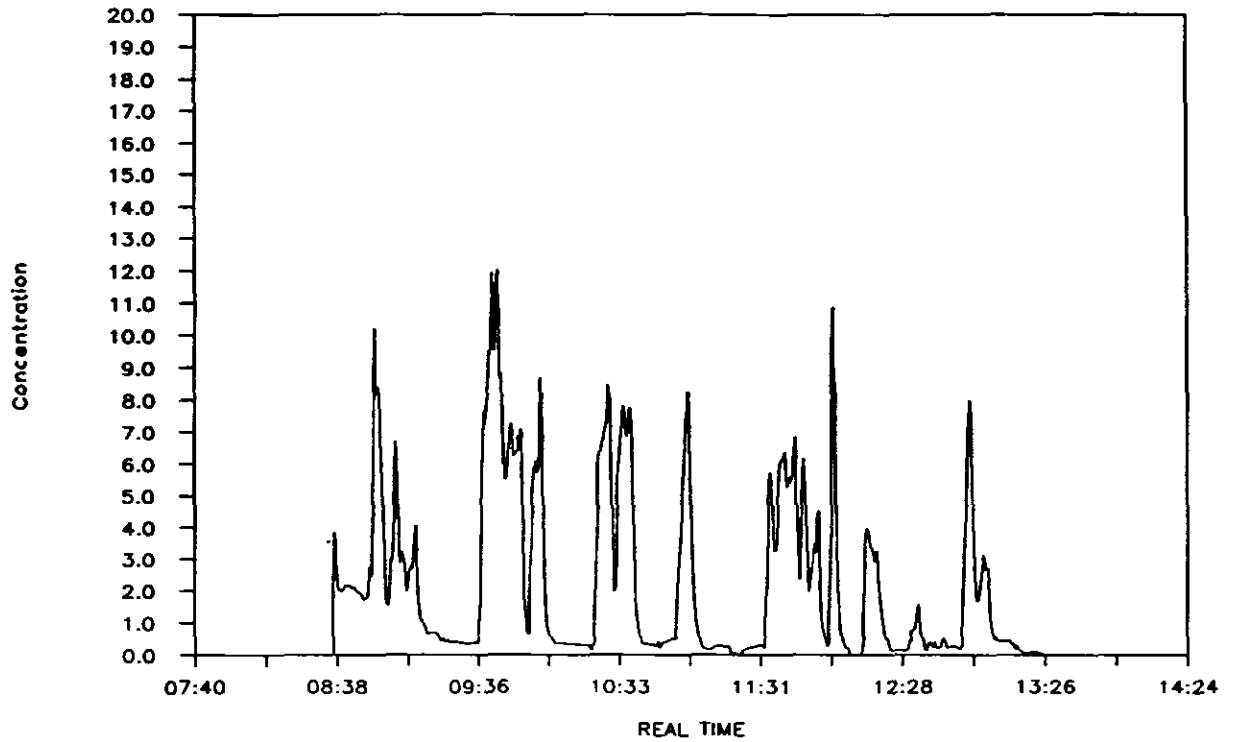

(b) TM-Data

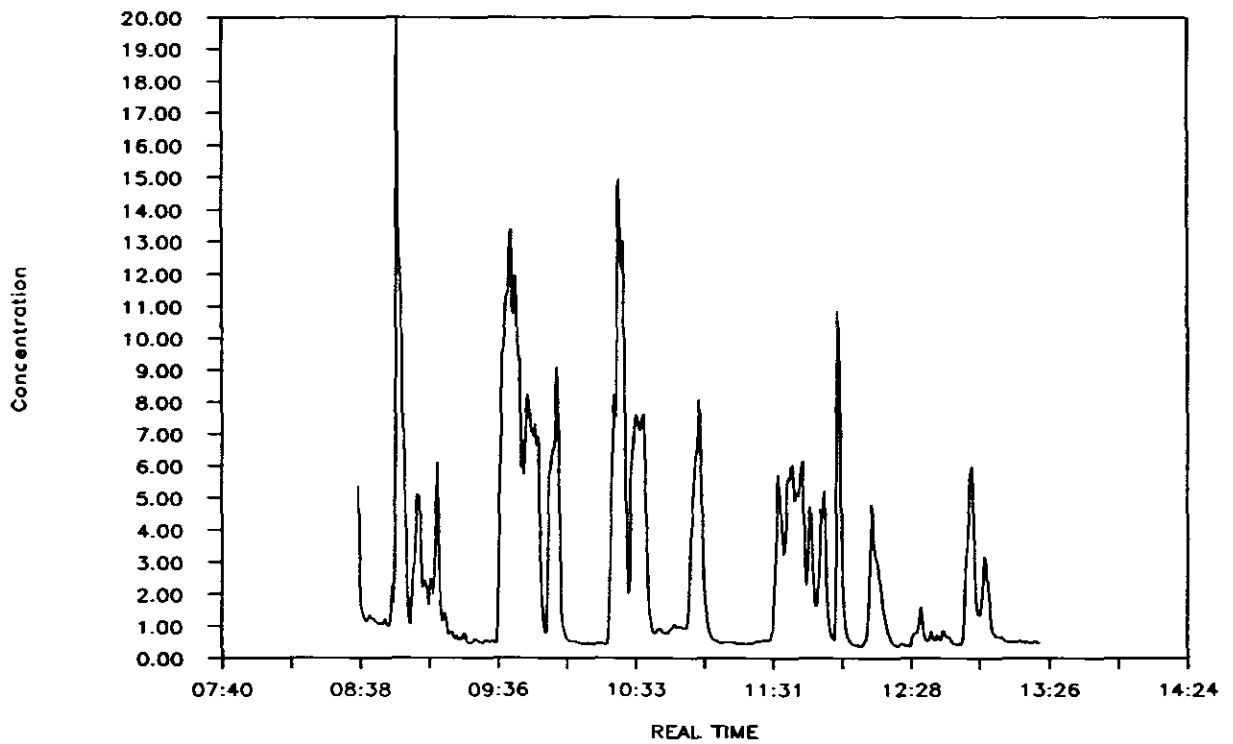

Figure 7. The shift-length concentration recordings (in an arbitrary unit) at the wall section WF of Mine A by (a) SIMSLIN II and by (b) TM-DATA. The time scales of (a) and (b) are in hours and minutes.

consisting of electronically controlled constant-flow pumps, Casella cyclones and glass fibre or the Millipore filters for respirable mass concentration measurement. Silver membrane filters have also been used for airborne dust collection for mineralogical analysis. Our dust research work will be directed more toward the assessment and promotion of dust source control technologies. For assessing the effectiveness of a dust suppression technique, a real-time dust monitor (SIMSLIN II or TM-DATA) supplemented by the gravimetric samplers chosen for our routine dust sampling work will be used.

REFERENCES

1. *Respirable Dust in the Mineral Industries: Health Effects, Characterization and Control*. 1st Ed., pp 51-59. R.L. Frantz and R.V. Ramani, Eds. The Pennsylvania State University, University Park (1988).
2. *Aerosols in the Mining and Industrial Work Environments Volume 3*, 1st Ed., pp 759-775. V.A. Marple and B.Y.H. Liu, Eds. Ann Arbor Science, Ann Arbor (1983).
3. *Inhaled Particles III Volume 2*, 1st Ed., pp 903-917. W.H. Walton, Ed. Unwin Brothers Limited, Surrey (1970).

ACKNOWLEDGEMENTS: We acknowledge the mine management and staff for providing help and support for the respirable dust research program. Technical assistance was provided by Messrs. D.J. O'Brien and L.S. O'Leary. We also thank Miss G.L. LeBlanc for assistance in the data processing.

MEASUREMENT STRATEGIES IN U.S. UNDERGROUND COAL MINES

THOMAS F. TOMB

Mine Safety and Health Administration, Pittsburgh, Pennsylvania, USA

ABSTRACT

The 1969 Federal Coal Mine Health and Safety Act (ACT) mandated standards for occupational exposures to respirable coal mine dust. For mine environments where the respirable dust contains less than 5 percent quartz the standard is 2.0 milligrams of dust per cubic meter of air (mg/m^3), where the respirable dust contains more than 5 percent quartz the standard is adjusted according to the quartz percentage. The Act also required mine operators to carry out a dust sampling program. This paper presents an overview of the current methods used in the United States of America to assess exposures to respirable dust in coal mines, the sampling strategies used to enforce the mandatory dust standard, the sampling requirements of coal mine operators and a description of the laboratory used to process the more than 100,000 samples per year collected by the coal mine operators.

ENFORCEMENT PROGRAMS (STRATEGIES)

Since December of 1969, the United States of America has had a Federally mandated respirable dust standard of $2.0 \text{ mg}/\text{m}^3$ for its underground coal mine environments. Respirable dust, for the purpose of this standard, is defined as the fraction of dust recommended by the British Medical Research Council (BMRC) and adopted by the Johannesburg Pneumoconiosis Conference in 1959. The sampling efficiency curve representative of the respirable dust criteria adopted at that conference is shown in Figure 1. Particle diameters in this figure refer to equivalent spherical diameters, which are defined as the diameter of spherical particles of unit density having the same falling velocity as the particles in question.

Because of the recognized increased health risk associated with exposure to quartz (crystalline silicon dioxide), the mandated exposure standard is to be adjusted (reduced) when the quartz content in the respirable dust exceeds 5 percent. The adjusted standard is determined by dividing the percent quartz in the respirable dust into the number 10 (i.e., 10% SiO_2).

In the United States there are two programs to enforce the mandatory respirable dust standard, a program conducted by the mine operators in accordance with mandated regulatory requirements and a program conducted by the Federal government. Under the operator's program each operator is required to collect five respirable dust samples from a "designated occupation," the occupation on a coal getting operation that previous sampling has shown to have the highest dust exposure, in each coal getting operation every two months. The samples must be collected on consecutive production shifts or on production shifts on consecutive calendar days.

The collected samples are sent by mail, within 24 hours after collection, to a central laboratory in Pittsburgh, Pennsylvania, where the amount of dust collected is determined by weighing.

A data card, shown in Figure 2, is submitted with each sample. The dust concentration is determined for each sample using the weight of dust collected, the time over which the sample was collected and the flow rate of the sampling device (in all cases this is 2.0 liters of air per minute). All samples are required to be collected for a full production shift (portal-to-portal).

The dust concentrations determined from these five samples are averaged. The average concentration is then compared to the $2.0 \text{ mg}/\text{m}^3$ dust standard (or adjusted standard) to establish compliance or noncompliance with regulatory requirements. In addition to the five samples collected bi-monthly on the designated occupation, the mine operator is

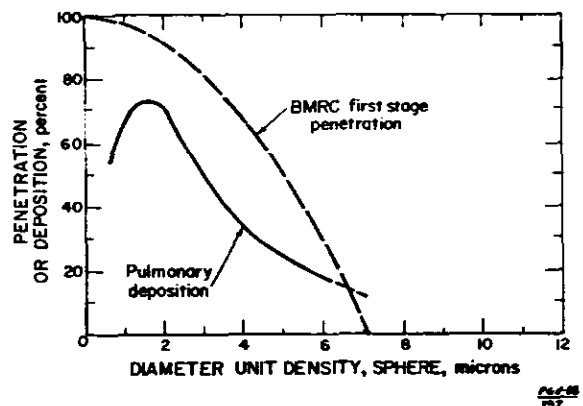

Figure 1. Comparison of BMRC respirable size criteria with pulmonary deposition curve.

also required to collect an additional sample bimonthly at specified locations throughout the mine. These locations are strategically selected so that the environment where miners normally work or travel is monitored for compliance with the respirable dust standard. If at any time it is determined from any of these samples that the respirable dust standard is exceeded, five additional samples are collected (either on consecutive days or consecutive production shifts) at the site where it was determined that the applicable standard may be exceeded. The dust concentrations determined from these samples are averaged and compliance is determined using the applicable standard for the area where the samples were collected. In accordance with regulatory requirements, the mine operator also submits to the Federal government a ventilation system and a methane and dust control plan which are to include: sources of dust generation in the outby areas of the mine, methods being used to control dust at these sources of dust generation and the specific location of places where samples will be collected to monitor the levels of dust in areas where miners normally work or travel. Also specified in the plan are the parameters characterizing the measures that are being used to control dust at the coal mining (getting) operation. The typical parameters specified include the quantity and velocity of air used to ventilate the face, the quantity and pressure of water and the number, type and location of nozzles used in the water spray system.

The Federal government's program to enforce the legislated respirable dust standard(s) consists of a mine inspector visiting each coal mining operation to approve, or check for compliance, that portion of the ventilation and dust control plan that describes the measures to be used by the mine operator to control respirable dust levels in the mine environment. To approve the "dust control" portion of the plan, an inspector will collect a personal sample on at least five miners working in the immediate area of the coal mining operation where the parameters described in the plan are being used to control the dust. If the type of mining is "room and pillar" employing continuous mining equipment, one sample must be collected from the environment of the continuous miner operator, one from the environment of the roof bolter operator and three from other occupations working in the immediate area. Typically these other three samples are representative of the environments of shuttle car operators, continuous miner operator helpers and laborers. If the mining operation is a longwall mining operation, the samples are representative of the shearer operators and shield (jack) setters.

The sampling equipment is normally mounted on the miners (referred to as personal sampling) prior to the start of the shift and removed after the shift is finished. After the samplers are removed from the miners, a mine data card is completed and the sample and data card taken to a local Federal enforcement laboratory for processing. The respirable dust samples collected are weighed to a tolerance of ± 0.1 mg which is the same as for those samples collected by the mine operators. After the samples are weighed and the net weight of the collected dust determined, the concentration of dust, in mg/m^3 , is calculated using the weight of the dust collected and the volume of air sampled.

To determine if the parameters being used to control dust are

effective in reducing the respirable dust level in the environment to the applicable standard, the dust concentrations determined from the five samples are averaged. For the plan to be considered adequate, the average dust concentration must be below $2.0 \text{ mg}/\text{m}^3$ and the concentration of no individual sample can be greater than $2.0 \text{ mg}/\text{m}^3$. If the average concentration determined from the five samples exceeds $2.0 \text{ mg}/\text{m}^3$, the work area is found to be in noncompliance and the mine operator must improve the practices being used to control dust and specify these changes in his dust control plan.

If the average concentration determined from the five samples is below $2.0 \text{ mg}/\text{m}^3$, but one or more of the individual samples is greater than $2.0 \text{ mg}/\text{m}^3$, then sampling continues on all five occupations on subsequent production shifts. Sampling is continued until the average concentration determined from the individual occupation samples collected on

Dust Data Card

1. Cassette Number _____

2. Mine ID Number _____ 3. Contractor Code _____

4. Mine Name _____

5. Company Name _____

6. Date Sampled _____ 7. Sampling Time _____
 Mo. Da. Yr. (min)

8. Tons This Shift _____ **ATTACH CASSETTE HERE**

9. Type of Sample (select one)

(1) designated occ (ug)
 (2) nondesignated occ (ug)
 (3) designated area (ug)
 (4) designated work position (sur)
 (5) part 90 miner

10. MMU DA/SA _____ 11. Occ Code _____

12. Part 90 Miner Sampled
 SSN _____

13. Certified Person
 SSN _____
 Signature _____

Laboratory Analysis
 Final Weight _____
 Initial Weight _____

Weighed By _____ OSP Checked By _____ Void Code _____

Date Processed _____

RETURN THIS COPY TO MSHA
 WITH CASSETTE. 400101

Figure 2. Mine data card.

consecutive production shifts and the average concentration determined from samples collected on the same shift are both equal to or less than 2.0 mg/m^3 . No more than five production shifts are sampled.

As previously discussed, the 2.0 mg/m^3 respirable dust standard is reduced whenever it is determined that the quartz content of the respirable dust exceeds 5 percent. Determination of the quartz percentage of the respirable dust is based on the analysis of a selected number of samples collected during the plan approval process. Those samples typically selected for analysis are the designated occupation sample, all roof bolter samples and any other sample that may be suspected of having a high quartz percentage.

After sampling has demonstrated that the procedures specified in the plan for controlling dust are adequate, subsequent inspections (up to three) during the year are limited to checking on conformance with the dust control plan; i.e., no dust samples are collected, only dust control procedures are evaluated.

RESPIRABLE DUST SAMPLING INSTRUMENTATION

To measure the respirable dust concentration of coal mine environments in the United States, a two-stage sampling instru-

ment is used. The instrument, commonly referred to as a personal respirable coal mine dust sampler, is shown in Figure 3. The sampler was designed to be an instrument that was capable of sampling the environment to which a miner is exposed during his full work shift. Therefore, the instrument has the flexibility of either being mounted on a person (as shown in Figure 4) to obtain his exposure or of stationary mounting to obtain measurements of any general environment where it is located.

The sampler consists of a 10 mm diameter nylon cyclone, a filter and a pump. The 10 mm nylon cyclone, the first stage of the sampling system, separates the sampled aerosol into two fractions: a respirable fraction and a nonrespirable fraction. The particle selectivity curve that defines the separated fractions is shown on Figure 5.

The nonrespirable fraction is collected and retained in the cyclone (Figure 6) while the respirable fraction passes through the cyclone and is collected on a 37 mm diameter, 5 micrometer pore size, vinyl metrical membrane filter. The filter is preweighed by its manufacturer to a precision of ± 0.1 milligram. The cyclone and filter assembly, commonly referred to as the "sampling head," is designed to be mounted on the miner at his "breathing zone."

The pump, used to induce air into the sampling system, is

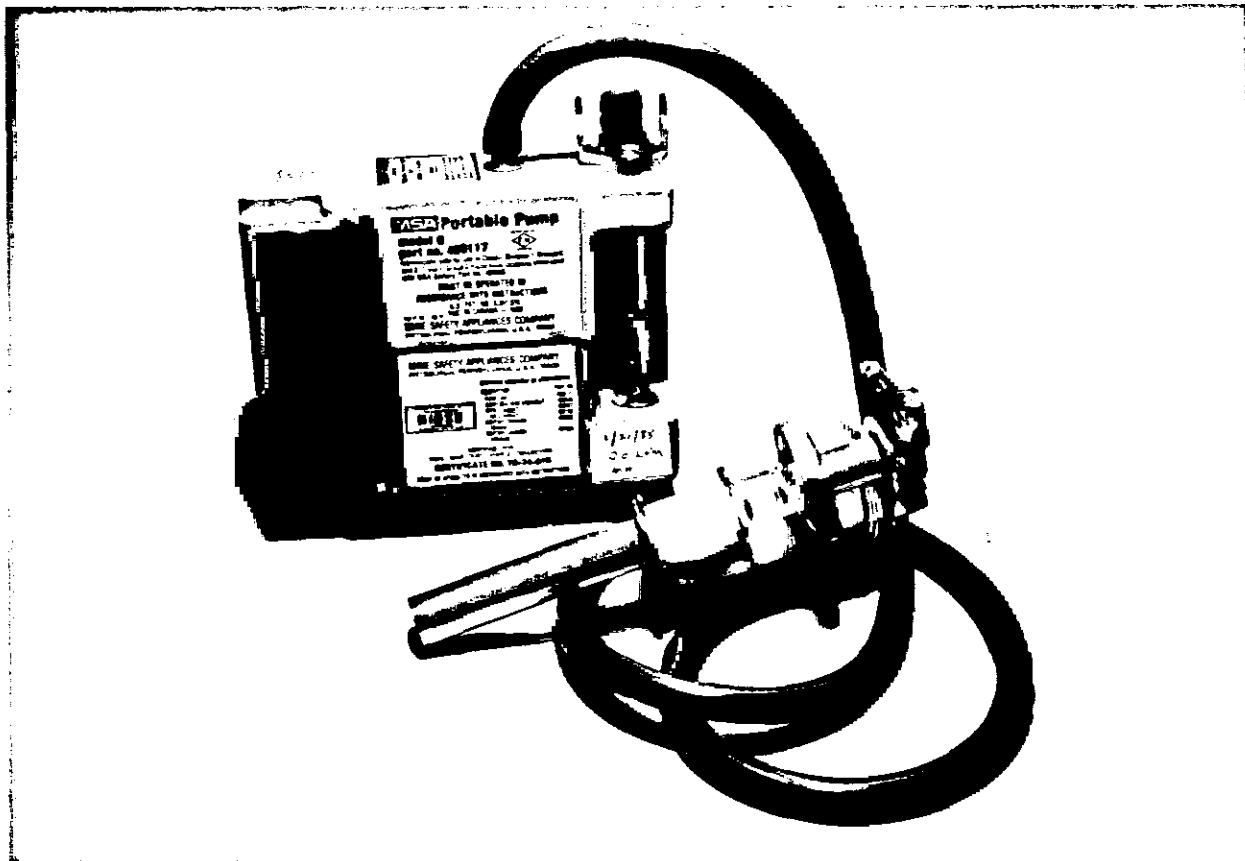

Figure 3. Personal respirable dust sampler.



Figure 4. Personal sampler worn by miner.

battery powered and can be easily worn by a miner during the performance of his duties. It weighs less than one kilogram and has overall dimensions of approximately 5 cm × 10 cm × 13 cm.

Air is sampled at the rate of 2.0 liters per minute (± 0.1 liters per minute). Because the 2.0 mg/m³ dust standard is based on measurement data obtained with an instrument that sampled with respect to the BMRC selectivity curve shown in Figure 1, respirable dust concentrations determined from measurements obtained with the personal coal mine dust sampler must be multiplied by a factor of 1.38 before the measurements can be used to determine compliance with the

mandatory dust standard.

PROCESSING COAL MINE OPERATOR DUST SAMPLES

As a result of the Federally mandated regulatory program, approximately 110,000 dust samples are collected by mine operators each year. These samples and associated data are mailed to the Federal government's central processing laboratory located at Pittsburgh, Pennsylvania.

At the central processing laboratory, samples are processed in a "clean room" environment. The laboratory is maintained

at a slight positive pressure to limit the entry of extraneous dust from surrounding work areas. The environment in the room where samples are weighed is maintained at $23^{\circ} \pm 1^{\circ}\text{C}$ and 50 percent ± 5 percent relative humidity.

Prior to weighing, samples are vacuum desiccated to remove moisture that may be present on the sample. The internal pressure of the desiccator chamber is reduced to 5 mm Hg and held at that pressure for 15 minutes.

Since January, 1985, respirable dust samples have been processed using the Automated Weighing System (AWS) shown in Figure 7. The AWS is a robotic system which has been designed for unattended weighing of filter capsules on a Mettler AE163 analytical balance.

The robotic arm (Figure 8) has the ability to rotate 360° around its central vertical axis, move up and down its vertical axis as well as in and out from the horizontal axis. At one end of the robotic arm is a "hand" with a pair of fingers which may be made to open and close as well as rotate 180° in wrist-like movements around the arm's horizontal axis. The system is designed so that the robot can sequentially process up to 200 samples from five trays without manual intervention. Processing time for 200 samples is approximately four hours.

Performed tasks are programmed into a power and event controller. The power and event controller zero's the balances before weighing each sample, switches a relay to select either of two balances, activates a solenoid to open and close a balance door and to sound an alarm buzzer when manual intervention with the AWS is required. Upon completion of a weighing, the controller activates a printer which prints the weight of each filter capsule and a sequence number on a 1 cm x 5 cm pressure sensitive label. The label is subsequently affixed to the data card.

The Mettler Model AE163 analytical balance used with the AWS is shown in Figure 9. This state-of-the-art analytical balance has a weighing precision of ± 0.02 mg. Each balance is calibrated twice daily and checked with a Class M certified

calibration weight. A radioactive deionizing unit is used to eliminate the presence of static charge on filter capsules. To isolate vibrations, the balances are positioned on a marble table weighing approximately 320 kg.

The AWS has been programmed to systematically weigh a sample twice on two different Mettler AE163 balances. One in eight of each filter capsule weighed is reweighed on the second balance. If the weight difference obtained between the two balances is within ± 0.1 mg, the weighings are considered to be within tolerance and weighings are continued. If the weights are out of tolerance, an alarm sounds and both balances are recalibrated. The system then reweighs the last seven filters, performs another quality control check weighing and continues processing additional samples if the check weights are within the established tolerance.

As previously discussed, each respirable dust sample is

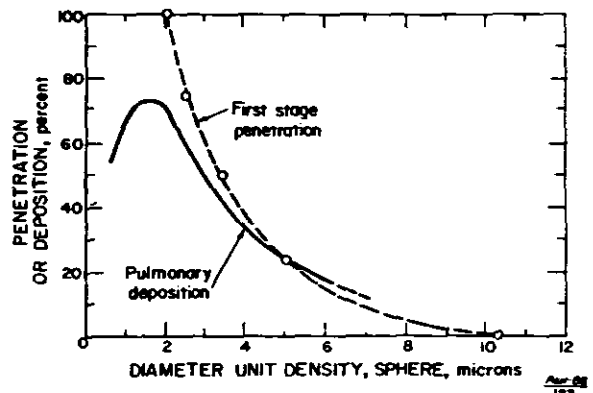

Figure 5. Comparison of the 10 mm diameter cyclone selectivity curve with pulmonary deposition curve.

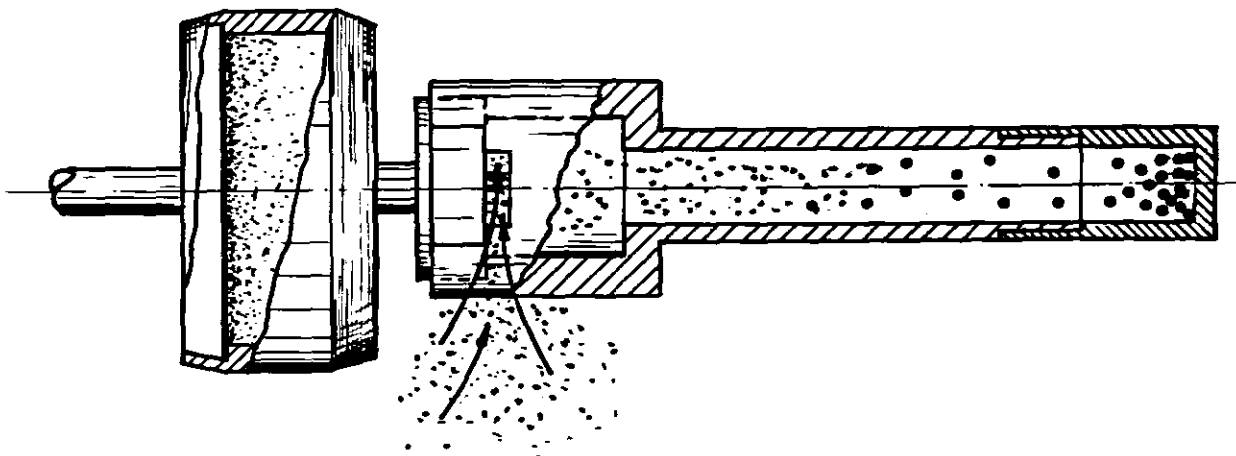

Figure 6. 10 mm cyclone with filter.

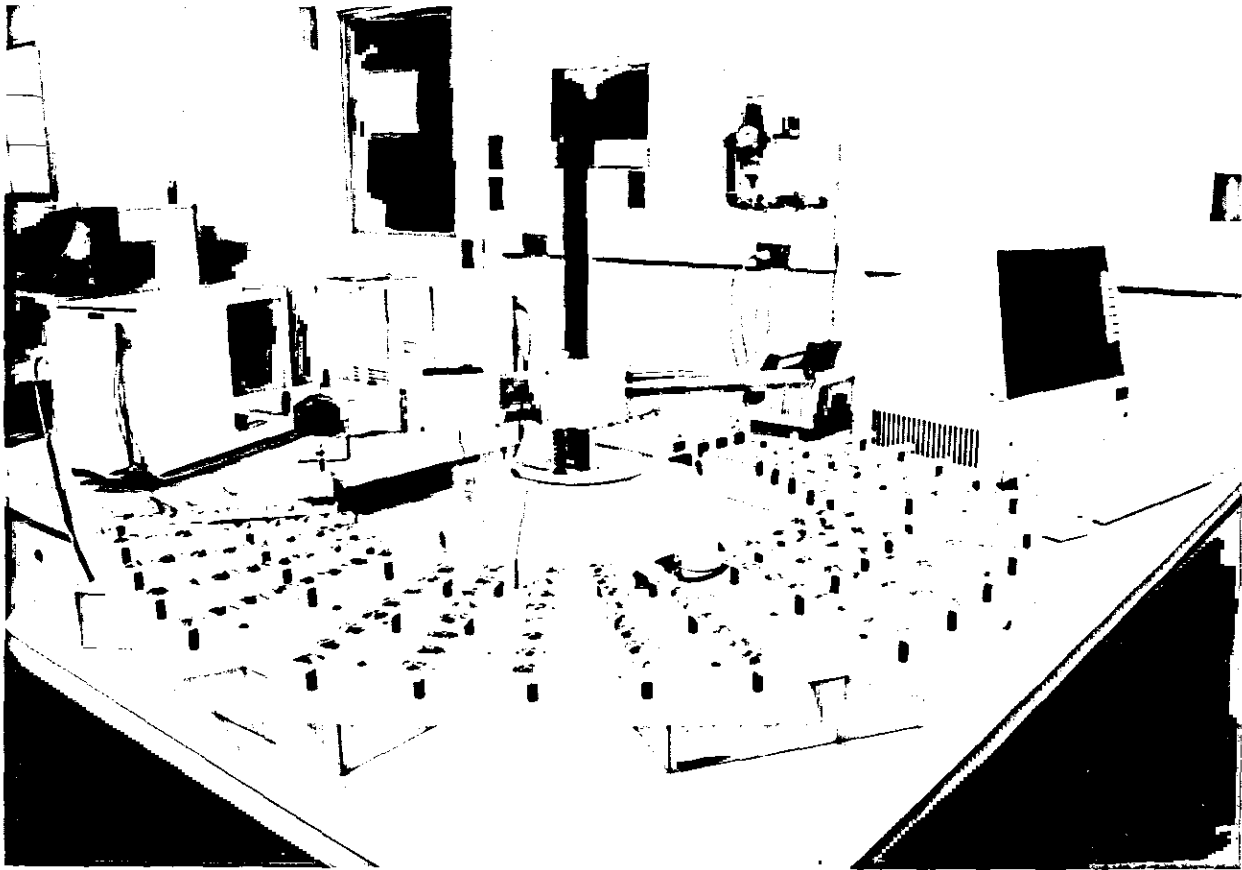

Figure 7. Automated weighing system.

accompanied by a mine data card (Figure 2). The data on each card is manually transcribed (Figure 10), in numeric notation, onto magnetic discs. Each card contains 62 keystrokes or digits. Data transcription is verified using a double entry system. Data retranscribed by a second operator is compared to that originally transcribed. The verifying operator is alerted to resolve errors or mismatched data. All disks generated during the day are then machine edited for completeness and accuracy. After editing, all data is accumulated and telecommunicated to an Information Systems Center in Denver, Colorado.

The information telecommunicated to the Information Systems Center is compiled and the respirable dust concentration for each sample calculated. A copy of all the data and sample results are mailed directly to the mine operators. The results are also telecommunicated to local enforcement offices which have interactive access to all dust data file information.

SUMMARY

The promulgation of a respirable dust standard for underground coal mine environments and the programs instituted to enforce that standard have resulted in a more healthful working environment for U.S. coal miners. As shown in Figure 11, occupational exposures have steadily decreased since promulgation of the respirable dust standard. However, as the data on this graph also depicts, the reduction of dust levels on longwall mining operations has not been as great as on the other types of mining operations. Work still needs to be done to develop methods to control dust on longwall mining operations.

The program requiring coal mine operators to sample their mine environments and to submit the samples to the Federal government for analysis has been effective in reducing underground respirable dust levels, and has provided the impetus for them to institute procedures to control dust.

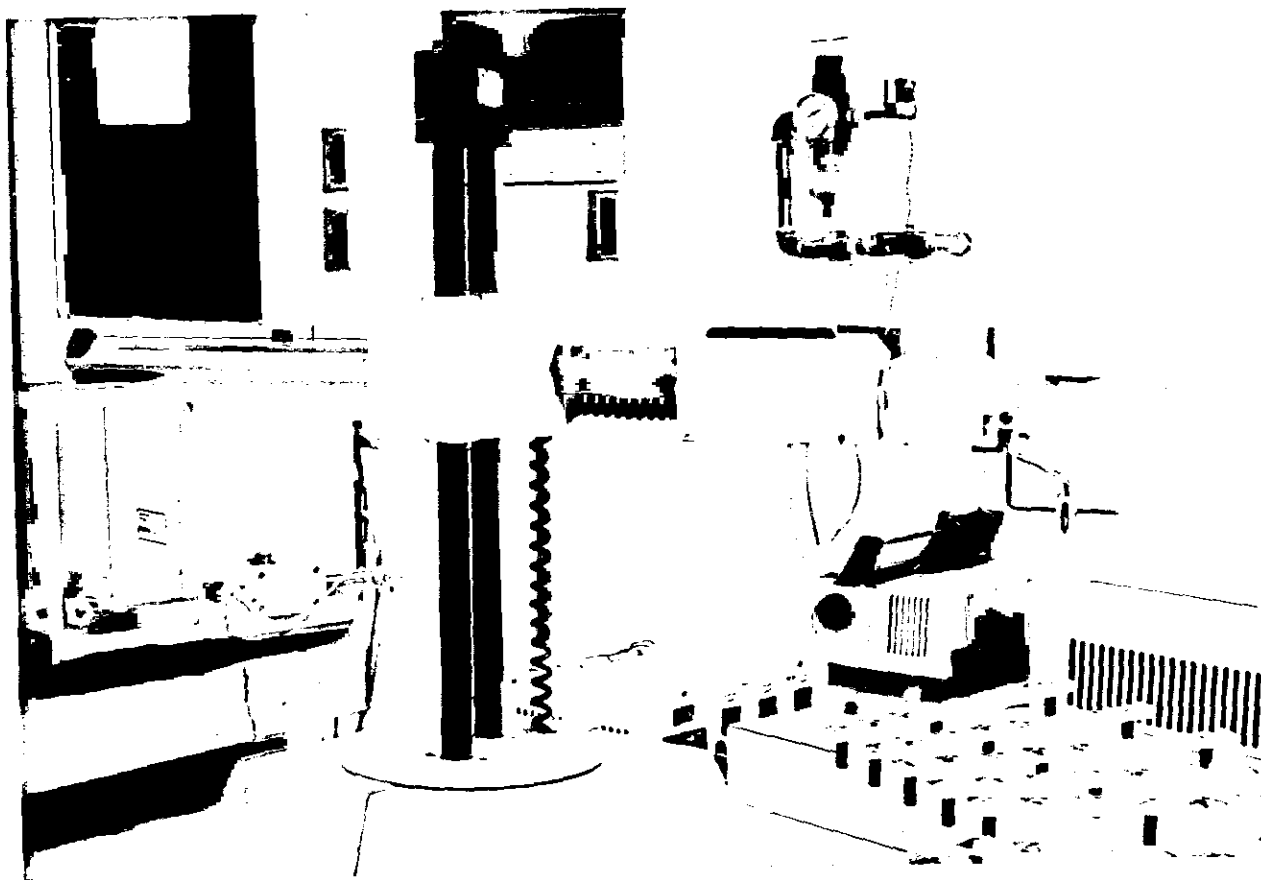

Figure 8. Robotic arm.

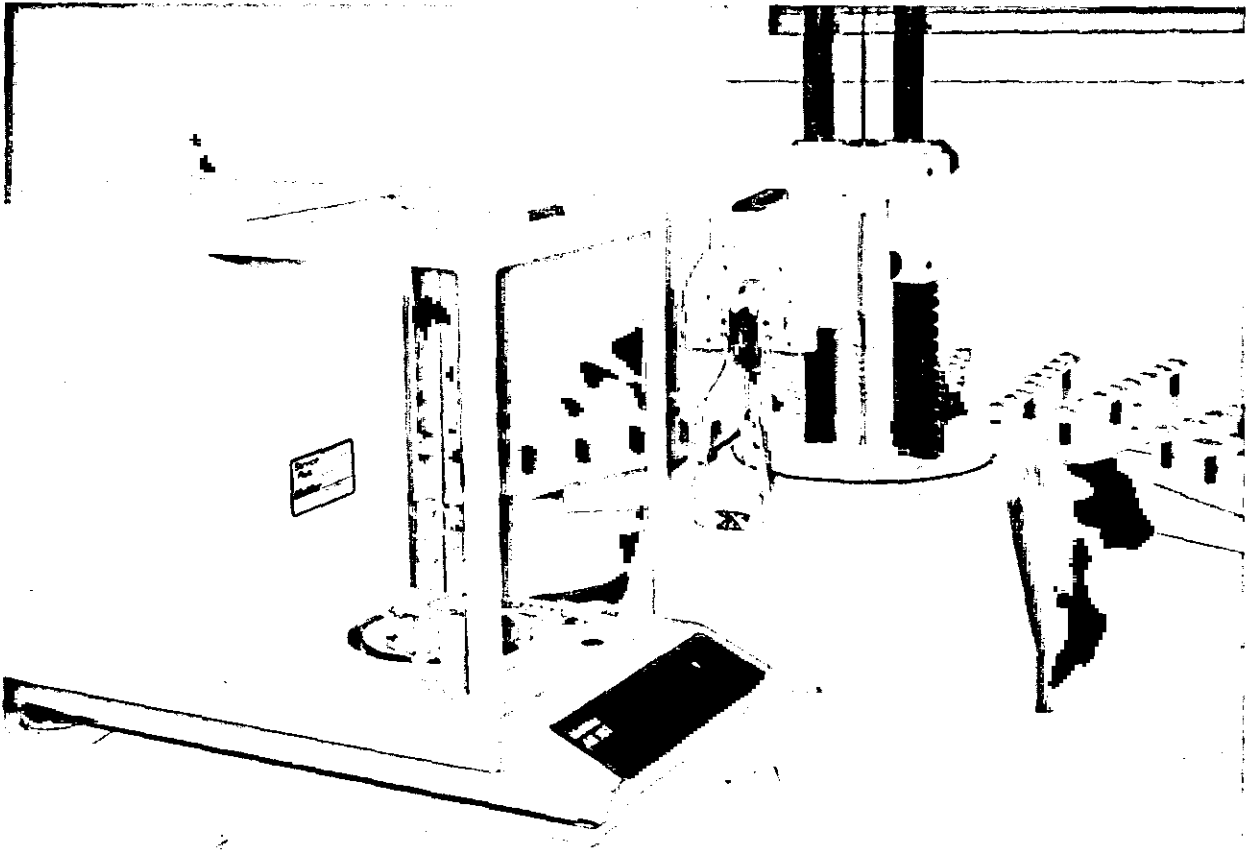

Figure 9. Analytical balance used with automated weighing system.



Figure 10. Data processing station.

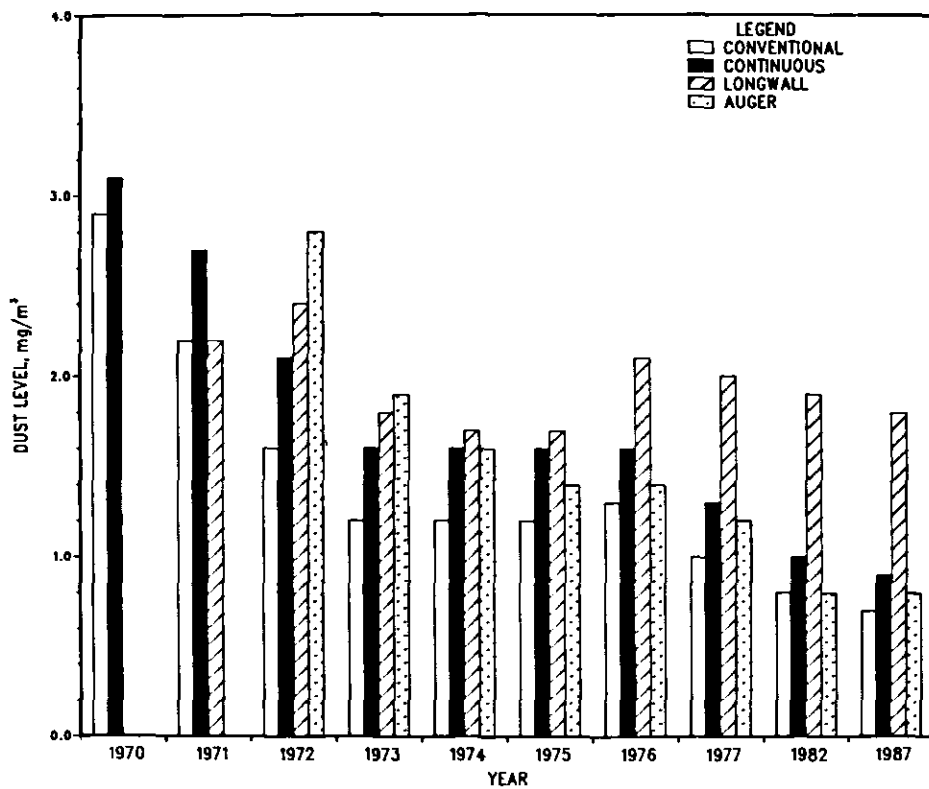

Figure 11. A yearly comparison of dust levels for four types of mining.

THE THRESHOLD LIMIT VALUE FOR VARIOUS FORMS OF AMORPHOUS SILICA

RONALD S. RATNEY, Ph.D., CIH

ACGIH Threshold Limit Value Committee (Chemical Agents), Bedford, MA, USA

Silica is the common name for silicon dioxide (SiO_2). In silica each silicon atom is covalently bound to four oxygen atoms which are arranged tetrahedrally around it. Each oxygen atom is bound to two silicon atoms. In the crystalline forms of silica the silicon and oxygen atoms are arranged in a highly ordered lattice which extends infinitely in all directions. Of course, the lattice is not truly infinite since it must end at the surface of the solid. The surfaces of crystalline silica particles or macroscopic pieces are bounded by flat surfaces joined at sharp straight edges. In some forms of crystalline silica such as tripoli or quartzite, the surfaces and edges may have been worn away to produce what appears to be amorphous particles.

All naturally occurring crystalline silica was formed by crystallization from aqueous solution or from molten magma. Depending on the temperature and pressure at which the crystallization takes place, one of three different geometrical arrangements of the silicon and oxygen atoms will be formed. The most common crystalline form of silica is quartz, which occurs as solid crystals from several inches in size down to microscopic dimensions. Other forms of crystalline silica are cristobalite and tridymite.

Under several natural and artificial conditions, silicon dioxide will form solids with no overall spatial ordering of the atoms. These products are amorphous silicas. Solid objects and particles of amorphous silica do not display flat faces and sharp edges. More importantly, amorphous silicas do not display X-Ray diffraction patterns as do the crystalline forms. The several forms of amorphous silica display different physical and chemical properties and substantially different toxicological characteristics.

The only naturally occurring form of amorphous silica is diatomaceous earth whose particles are the fossil skeletons of microscopic marine plants known as diatoms. While alive these organisms extract silica from the sea water and deposit it in complex regular forms with numerous voids. In California and other parts of the world there are very large deposits of the mineral diatomite or diatomaceous earth consisting almost entirely of fossilized diatoms, and which is a highly porous substance with a very low bulk density. The overlying and surrounding rock frequently contains quartz which contaminates the final product. Some deposits contain traces of cristobalite, apparently formed by metamorphism.

Fused quartz, or more properly, fused silica, is formed by the relatively slow solidification of molten quartz. In the melt

there is no long range order. As it cools, the molten material becomes highly viscous and then solidifies so that the atoms become immobilized in their random positions. Fused silica is produced as lumps of glassy material but during crushing and grinding, respirable particles can be produced.

Glass or silica dissolves in sodium hydroxide to form a solution of sodium silicate, also known as water-glass. On acidification, this forms the insoluble flocculent precipitate of silicic acid (H_4SiO_4 or $\text{Si}(\text{OH})_4$). As water is eliminated between nearby SiOH groups Si-O-Si bridges are formed. Depending on the dehydration process, precipitated silica or silica gel is produced. These both can be considered to be partially hydrated silicon dioxide. Silica gel can be dried to a very low moisture content to form a granular product which absorbs water and polar organic substances with great avidity.

Fumed silica is produced synthetically by a vapor phase hydrolysis of silicon tetrachloride in a flame of hydrogen and oxygen. It is a widely used filler in paints, plastics and rubber and as an antiskid and antislip agent.

Elemental silicon is produced by reacting coke and silica sand (crystalline) in an electric arc furnace. If iron is included in the charge, the product is ferrosilicon. In both cases, silicon monoxide is apparently produced as a byproduct which escapes from the furnace and is oxidized by ambient oxygen to produce what can be called silica fume. Although it is not a deliberately manufactured product, baghouse dust from silicon and ferrosilicon furnaces has been used in the same way as fumed silica. Although both fumed silica and silica fume are fumes in the usual industrial hygiene sense (they are finely divided solids produced by condensation from the gas phase) their mode of formation and worker exposure are different. As is discussed below, the toxic effects are also quite different.

Precipitated silica and silica gel could be considered to be the prototypical nuisance dusts. The ACGIH considers a material to be a nuisance dust if it causes no adverse health effects when exposures are kept under reasonable control (e.g. near or below 10 mg/m^3) and further does not alter the lung air spaces, does not form collagen to a significant extent and whose tissue reactions are potentially reversible.³ Klosterkotter showed that silica gel injected intratracheally in rats did not cause fibrosis.⁶ Schepers et al observed no fibrosis in guinea pigs and rabbits exposed by inhalation at 126 mg/m^3 for two years.⁷ There were macrophage accumulations and mild proliferation of reticulin fibers. In a group of 165 workers exposed to precipitated silica estimated

to be near or below 10 mg/m^3 for an average of 8.6 years, Wilson et al observed no serial changes in pulmonary function or chest radiographs.⁹

The TLV or 10 mg/m^3 (total dust) assigned to precipitated silica and silica gel was not chosen to avoid any known adverse health effect.³ Rather it represents a recommendation for good industrial hygiene practice. Airborne exposure above this level may reduce visibility, may cause unpleasant deposits in the eyes and nasal passages and may cause injury to the skin and mucous membranes by purely mechanical action.

Fumed silica and silica fume display entirely different toxicities. This contrast illustrates the confusion created by misidentification of the toxic substance in epidemiological studies and the risk of predicting toxicity on the basis of chemical similarity. As noted above, both products are true fumes, ultrafine solid particulates formed in gas phase reactions. However, fumed silica appears to be only slightly more toxic than precipitated silica and silica gel. ASTM standard E1156-87 reviewed three studies involving a total of 353 workers exposed for up to 32 years to fumed silica concentrations from 1.6 to 53 mg/m^3 .¹ No pulmonary dysfunction was observed except in smokers. Schepers exposed rats, rabbits and guinea pigs to fumed silica at 53 mg/m^3 for a year causing emphysema which reversed after exposure ceased and fibrosis which partially reversed.⁷ Groth observed significant interstitial hyperplasia and collagen deposition in monkeys exposed to 15 mg/m^3 of fumed silica for 13 months.⁴ However, the monkeys' lungs showed the presence of mineral dust which had apparently been inhaled in the wild or in captivity prior to purchase of the animals. No changes were observed in rats and guinea pigs similarly exposed.

On the other hand, several studies in the elemental silicon and ferrosilicon industries show that silica fume produces a unique complex of acute and chronic effects which are reversible after exposure ceases. The observations of Bowie at an African ferrosilicon plant are typical.² Brief high exposures to silica fume produce the symptoms of metal fume fever, which can persist for up to three months. Chronic exposure produces X-Ray and pulmonary function evidence of silicosis which regresses or disappears after cessation of exposure.

The TLV for fumed silica has been set at 10 mg/m^3 ; the value assigned to nuisance dusts.³ No value has been established for silica fume but a TLV of 0.2 mg/m^3 (twice the TLV for quartz) seems reasonable.

It is tempting to speculate on the causes of the radical difference between the two silica fume materials. In the case of silica fume, the effects may be produced by repeated high exposures but no airborne measurements are available to sup-

port this hypothesis. It is also possible that silicon and ferrosilicon workers are exposed to a much more freshly formed fume since they work at the tapping ports of the furnaces while the synthetic fumed silica may have aged for a few minutes before reaching the workers' breathing zones. Again there is no evidence to support this.

In contrast to the other forms of amorphous silica, the TLV for fused silica is based on very little actual data, animal or human. The Documentation references only two studies both published in the early 1950s; one an acute intraperitoneal injection in rabbits, the other an intratracheal instillation in rats.^{3,8,5} No inhalation experiments in animals or epidemiological studies in exposed workers have been published since then. Both references indicated that fused silica was less active in inducing a tissue reaction than crystalline quartz but no comparisons with nonfibrogenic forms of amorphous silica were performed. On the basis of the fact that there was a tissue reaction at all, a TLV of 0.1 mg/m^3 was established; the same as for quartz.³

Fused quartz is now used in several advanced technological products such as ablative surfaces for rocket reentry vehicles and in fiber optics. It is anticipated that more workers will be exposed to this hitherto exotic material and it is unfortunate that more solid toxicological data is not available.

REFERENCES

1. *ASTM Standard E1156-87. Health Requirements for Occupational Exposure to Synthetic Amorphous Silica.* American Society for Testing and Materials, Philadelphia (1987).
2. Bowie, D. St. J., *Ferro Alloy Workers' Disease.* *Cent. Afr. J. Med.* 24:81-86 (1978).
3. *Documentation of the Threshold Limit Values and Biological Exposure Indices, 5th Ed.* American Conference of Governmental Industrial Hygienists, Cincinnati (1987).
4. Groth, D.H., Moorman, W.J., Lynch, D.W., Stettler, L.E., Wagner, W.D., Hornung, R.W.: *Chronic Effects of Inhaled Amorphous Silicas in Animals.* In *Health Effects of Synthetic Particulates.* ASTM STP 732. Dunnom, D.D., Ed. American Society for Testing and Materials, Philadelphia (1981).
5. King, E.J., Mohanty, G.P., Harrison, C.V., Nagelschmidt, G.: *The Action of Different Forms of Pure Silica on the Lungs of Rats.* *Brit. J. Ind. Med.* 10:9-17 (1953).
6. Klosterkötter, W.: *Zur Frage der silikogenen Wirkung des amorphen Siliciumdioxide in Jotten.* K.W. Klosterkötter, W.: *Die Staublungenerkrankungen*, Vol. 2., pp. 73-84. Steinkopf, Darmstadt (1954).
7. Schepers, G.W., Durkan, T.M., Delahant, A.B., Creedon, F.T., Redlin, A.J.: *The Biological Action of Degussa Submicron Amorphous Silica Dust.* *AMA Arch. Ind. Health* 16:125-46, 203-244, 280-301 (1957).
8. Silverman, L., Moritz, A.R.: *Arch. Ind. Hyg. Occup. Med.* 1:499 (1950).
9. Wilson, R.K., Stevens, P.M., Lovejoy, H.B., Bell, Z.G., Richie, R.C.: *Effects of Chronic Amorphous Silica Exposure on Sequential Pulmonary Function.* *J. Occup. Med.* 21:399-402 (1979).

COMPARISON OF THE SAMPLING STRATEGIES RECOMMENDED BY THE EUROPEAN COMMUNITIES FOR THE PROTECTION OF WORKERS FROM THE RISKS RELATED TO CHEMICAL AGENTS AT WORK, ASBESTOS, LEAD AND MINE DUST

B. PRÈAT

IREA, Havermarkt 22, B-3500 Hasselt, Belgium

INTRODUCTION

The purpose of this paper is to evaluate the monitoring strategies implemented by the various European Directives on the exposures to airborne workplace contaminants.

Monitoring strategies to determine compliance with occupational health standards entail a number of requirements that are usually determined by consensus rather than through the scientific process.

Statistical models will be used to compare the proposed sampling strategies. Past research has shown that the concentration distribution of most air pollutants can be described as lognormal. Therefore, the analysis will be based on the lognormal distribution. Such distributions are completely defined by the geometric mean (GM, a measure of central tendency) and by the geometric standard deviation (GSD, a measure of the variability of exposures).

When a monitoring strategy provides consecutive shift or daily samples to determine compliance, the autocorrelation of the exposures should be taken into account.

DIRECTIVES OF THE EUROPEAN COMMUNITIES

The first Directive laid down by the Council of the European Communities is the Directive 80/1107/EEC of 27th November 1980 on the protection of workers from the risks related to exposure to chemical, physical and biological agents at work.¹ This is a global Directive providing for the laying down of individual Directives for specific agents.

Directive on Lead

The first of these individual Directives has been the Council Directive 82/605/EEC of 28th July 1982 regarding exposure to metallic lead and its ionic compounds at work.² Taking into account the biological half-life of the agent, the limit value for lead is based on the time-weighted average concentration over one week (40 hours). The strategy provides the following stages:

- initial designation if the sample exceeds 1/2 of the limit value;
- a quarterly sampling cycle in the first instance;
- the frequency of monitoring may be reduced to once a year if two consecutive measurements are below 2/3 of the limit value.

Directive on Asbestos

The Council Directive 83/477/EEC of 19th September 1983 relating to exposures to asbestos at work was the second individual Directive.³ Here the limit values are measured or calculated in relation to an eight-hour reference period. The general rule is to measure the level of asbestos at least every quarter.

This frequency may be reduced to once per year when the results of the two preceding measurements have not exceeded 1/2 of the limit value. As the time-weighted average over 8 hours has a greater standard deviation than the average over 40 hours,⁴ a lower action level has been chosen: namely 1/2 of the limit value instead of 2/3. If the concentration is lower than 1/4 of the limit value, monitoring is terminated.

Proposal for Modification of the Frame Directive 80/1107/EEC

On 6 June 1986, the Commission of the European Communities presented a proposal for modification of the Frame Directive 80/1107/EEC.⁵ The strategy is similar to the one for asbestos, except that the action level has been lowered to 1/3 of the limit value and the decision to end sampling is taken when the concentration does not exceed 1/5 of the limit. This proposal has not been approved and Technical Committee TC 137 of the CEN (European Committee for Standardization) has been invited to draw up its own sampling scheme for the determination of airborne hazardous substances at the workplace.

Draft Proposal of the Safety and Health Commission for the Mining and other Extractive Industries of the E.C. to the Governments of the Member States to reduce the risk to health associated with the exposure to fibrogenic mineral dust in the non-coal mining and quarrying industries.

This draft proposal, in its last version (Doc. 5761/10/85) of 19 May 1988, provides for the same measuring strategy as the Directive on asbestos. Moreover, it provides for an alternative approach towards dealing with the problem of exposure fluctuation by interpreting the limit in terms of the mean exposure over one year. Daily levels are allowed to exceed the limit if they are compensated by the days of low exposure so that the one-year time-weighted average remains below the limit.

Intuitively, it would appear difficult to accurately characterize the exposure over one year with only one, two or three isolated estimates of daily exposures. For example, in West German underground coal mines, the exposure over one year is estimated from averaging the results of 12 monthly measurements.

STRATEGY EVALUATION

An evaluation of the sampling strategies has been conducted using a lognormal model.

For this model, a value of 1.7 has been chosen for GSD, a typical value for the distributions of one-shift respirable dust concentrations in European underground coal mines (although it can vary from 1.2 to 3.0 in other work environments). When $GSD = 1.7$, it means that 5% of the shifts have a concentration exceeding 2.8 times the geometric mean or 2 times the arithmetic mean. Low values of GSD indicate good dust control. When $GSD > 2.5$, it is likely that there are no functioning engineering controls.⁶

Thus dust measurements carried out for industrial hygiene purposes, even performed with the same instruments at the same place, can provide very different results, implying capricious decisions concerning both compliance and controls. It is clear that this can lead to all forms and kinds of injustice and may have little to do with the degree of chronic hazard.

For the study of the autocorrelation, we have used the time series made up by a string of consecutive measurements recorded by a recently developed respirable dust continuous measuring instrument [HUND, Wetzlar, West Germany] set up in the tailgate of a German longwall coal face.⁷ Figure 1 shows the time series plot of the shift averages at the sampling point at 50 m from the face. It is seen that the range of the shift averages observed during a period of 138 consecutive shifts (4 shifts a day) exceeds a factor of 13.

Consider two concentrations, $c(t)$ and $c(t + h)$, at two shifts t and $t + h$, separated by the interval h . The autocorrelation between these two quantities is characterized by the variogram function $\Gamma(h)$ which in turn is defined as the expectation of the random variable

$$[c(t) - c(t + h)]^2/2.(4)$$

Figure 2 shows the experimental corresponding semi-variogram, to which the following theoretical model has been fitted:

$$\Gamma(h) = 0.15 + 0.11 (1.5 h/40 - 0.5 (h/40)^3),$$

where h is the time lag (i.e. the number of shifts between the sequences being compared). Using this model, allowing for the autocorrelation between the shift averages, GSD of the distribution of the five-shift average concentration over 5 days (one measurement every 4 shifts) can be estimated by using the following formula (Equation 12,(4)):

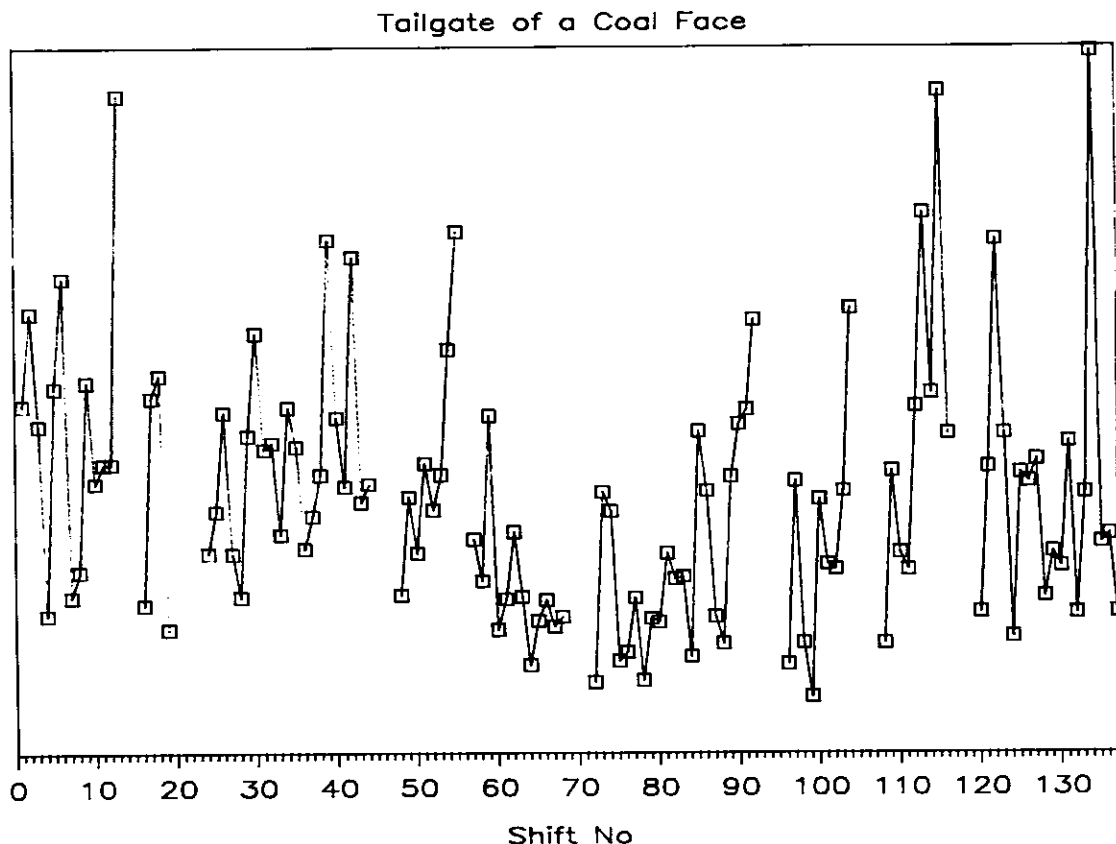

Figure 1. Respirable dust concentration.

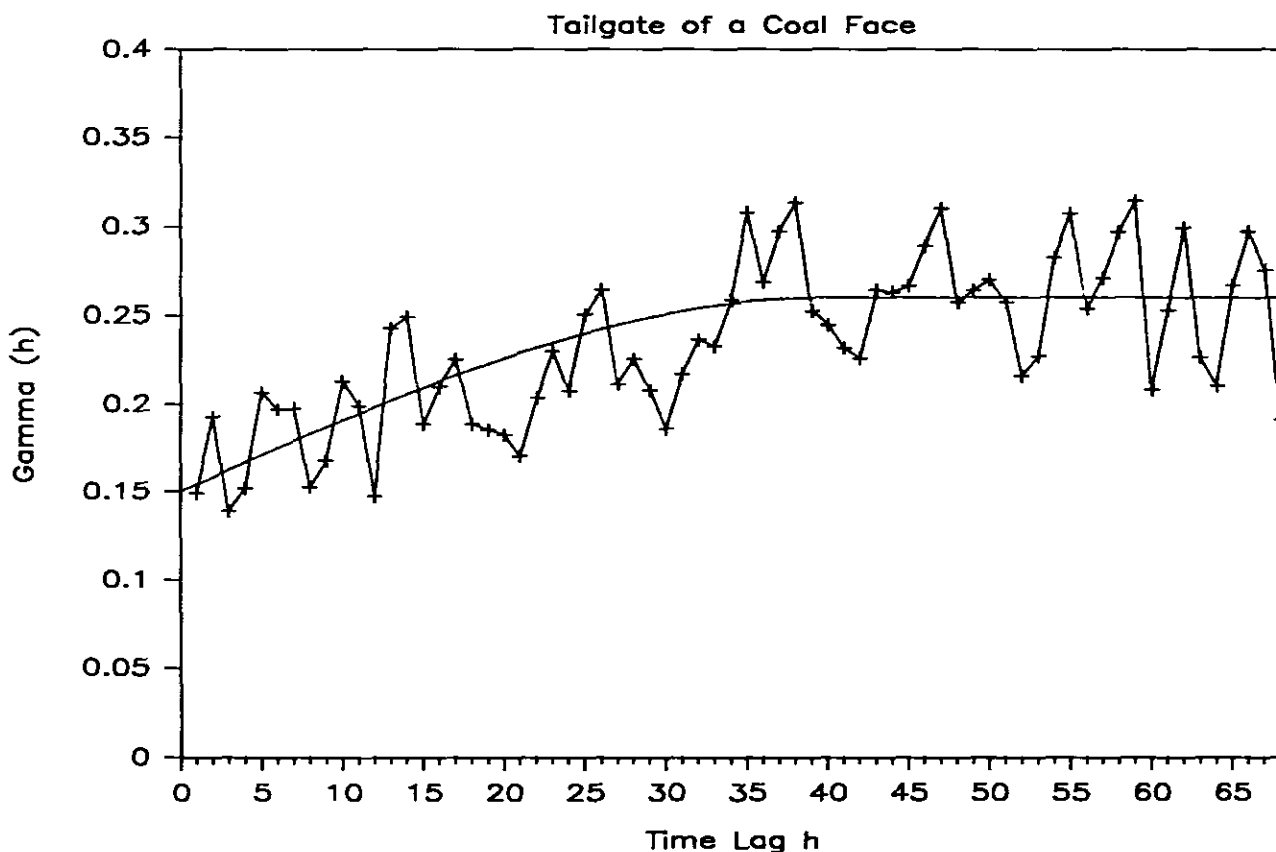

Figure 2. Semivariogram.

$$(\ln \text{GSD})^2 = (\ln 1.7)^2 - 1/10 (4\text{Gamma}(4) + 3\text{Gamma}(8) + 2\text{Gamma}(12) + \text{Gamma}(16)).$$

This leads to $\text{GSD} = 1.4$, instead of

$$\text{GSD} = \exp(((\ln 1.7)^2/5)^{0.5}) = 1.27$$

for the averages of five independent shift concentrations.

Figure 2 shows that, for this example, the time interval over which there is autocorrelation between the concentrations, covers 40 shifts (i.e., 10 days).

Note the pseudo-periodicity of the experimental semivariogram, with lower values at $h = 8$ and 12 shifts, showing a stronger autocorrelation between concentrations measured during the same shift at two or three days intervals. In this case, random sampling would be more appropriate.

Other work situations do not present any autocorrelation. Figures 3 and 4 show, by way of illustration, the respirable dust concentration in a mechanized road heading area.

The strategies were simulated for various values of the geometric mean with 1000 runs in each case. The results are illustrated in Figures 5 and 6 showing the operating characteristics of the monitoring strategies after a maximum monitoring duration of 5 years. From Figure 5, it is seen that the workplaces where the limit is exceeded more than 40% of the time are detected very quickly, usually in less than

5 years operation. Conversely, Figure 6 shows that the probability is very low for finding the workplace in compliance if the exposure exceeds the limit value during at least 40% of the shifts (i.e., with a mean greater than the health standard).

All this means that the compared strategies are extremely conservative. The probability of noncompliance if the mean is lower than the limit ("operator's risk" with all its associated engineering and administrative consequences) is much higher than the chance of finding the workplace in compliance if the mean is above the limit ("worker's risk"). This probability of escaping a citation being less than 5%.

The worker's risk with the Directive on Lead is higher than with the Directive on Asbestos and it is near-zero with the draft modification of the Frame Directive which appears to be the safest strategy but with the highest operator's risk, of unjustifiable expenses and labor problems.

CONCLUSION

As the design of monitoring strategies aims at keeping the "operator's" and "worker's" risks as low as possible, (0,05 being the goal for the last one) it may be concluded that the strategy provided in the Directive on Asbestos is the most efficient. Whilst this strategy allows for a reasonable level of risk for the worker's health, it imposes a lower sampling burden than the others. However the compliance outcome of these strategies is related to the fraction of days above the limit

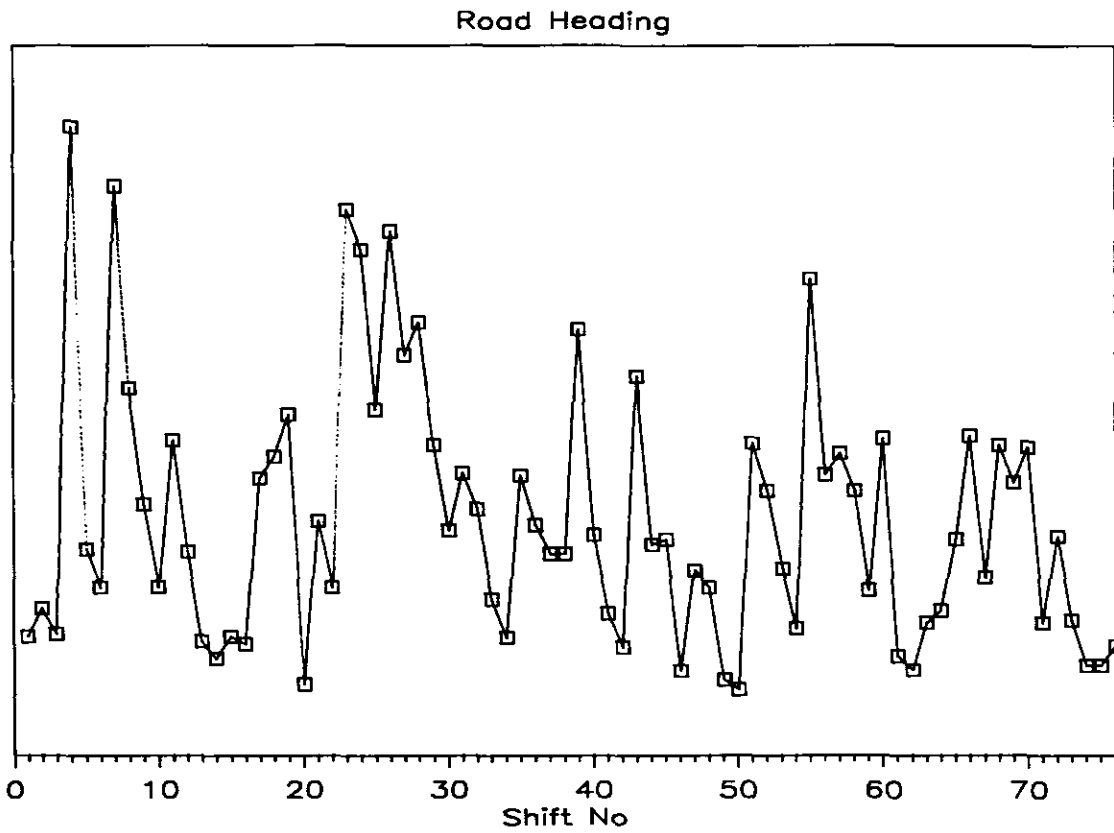

Figure 3. Respirable dust concentration.

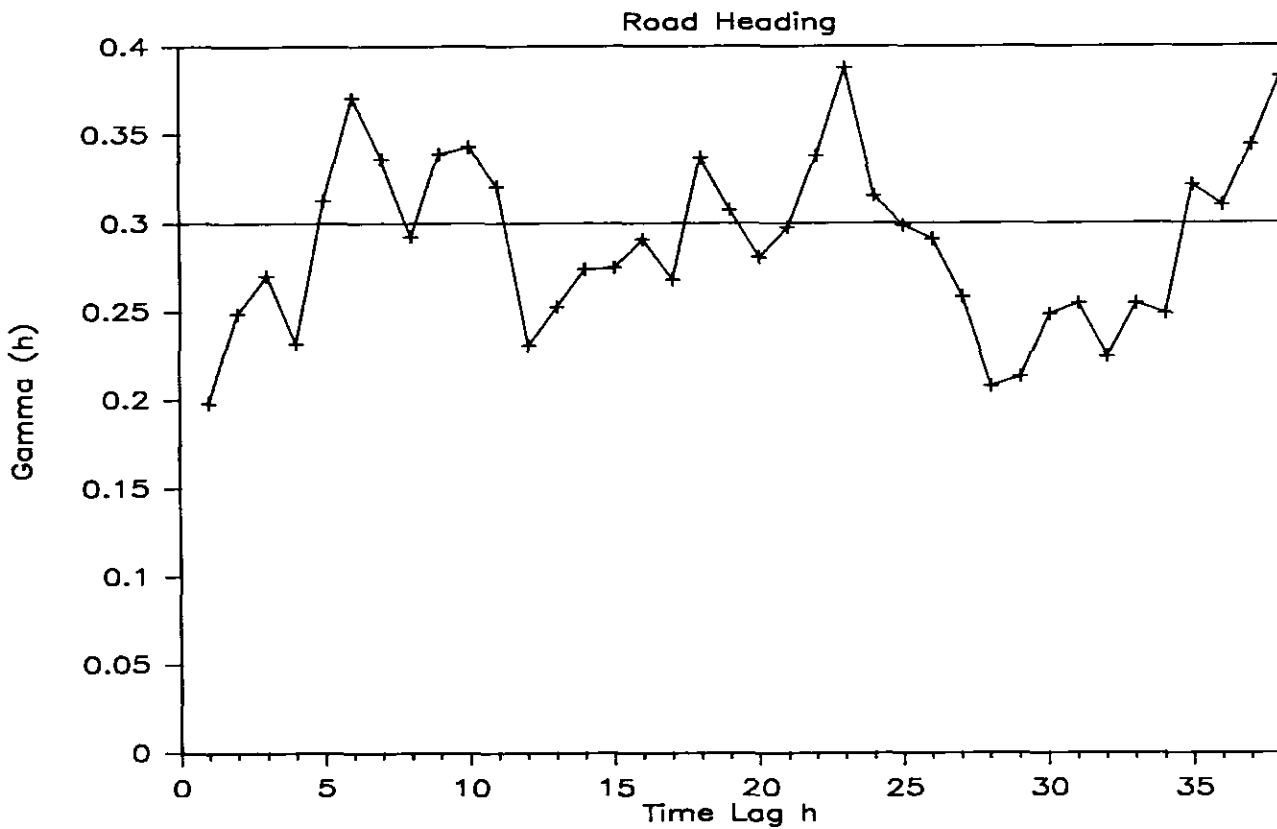

Figure 4. Semivariogram.

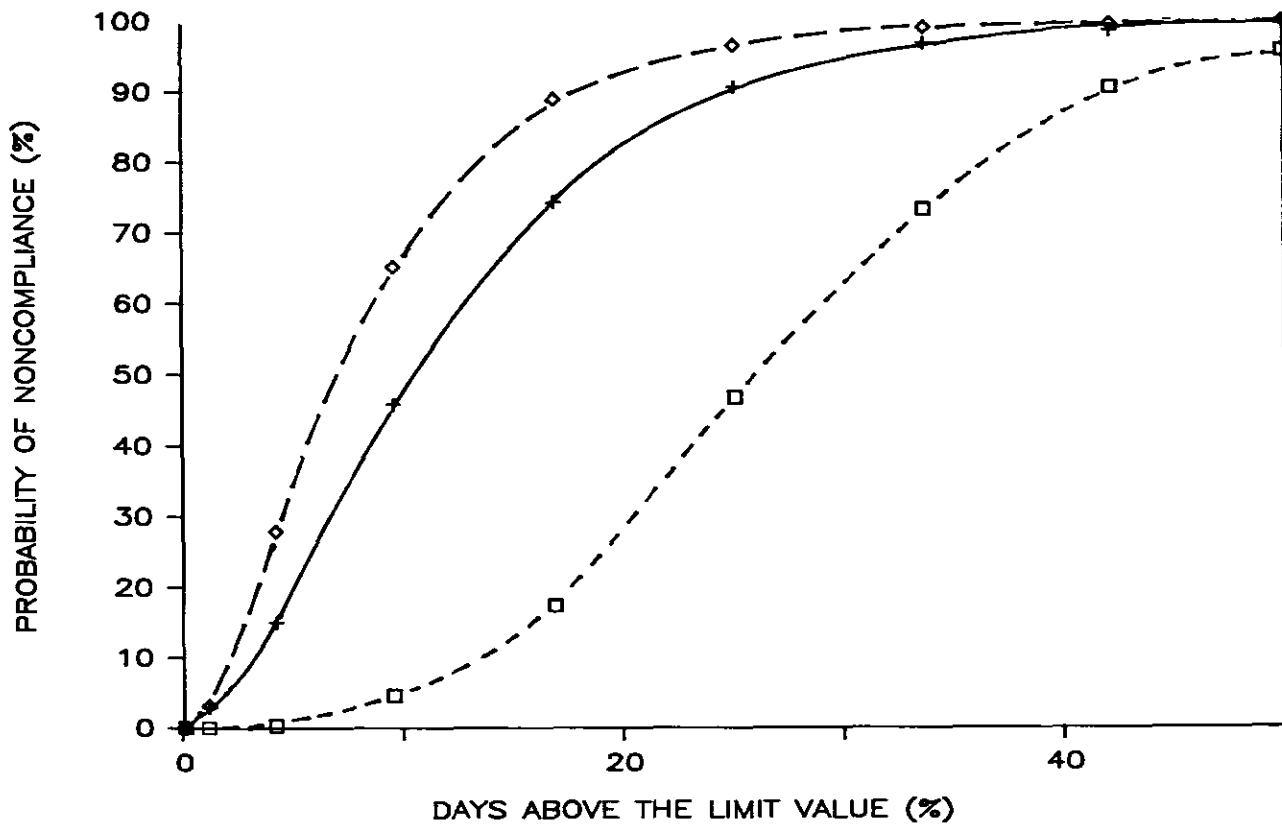

Figure 5. Operating characteristics.

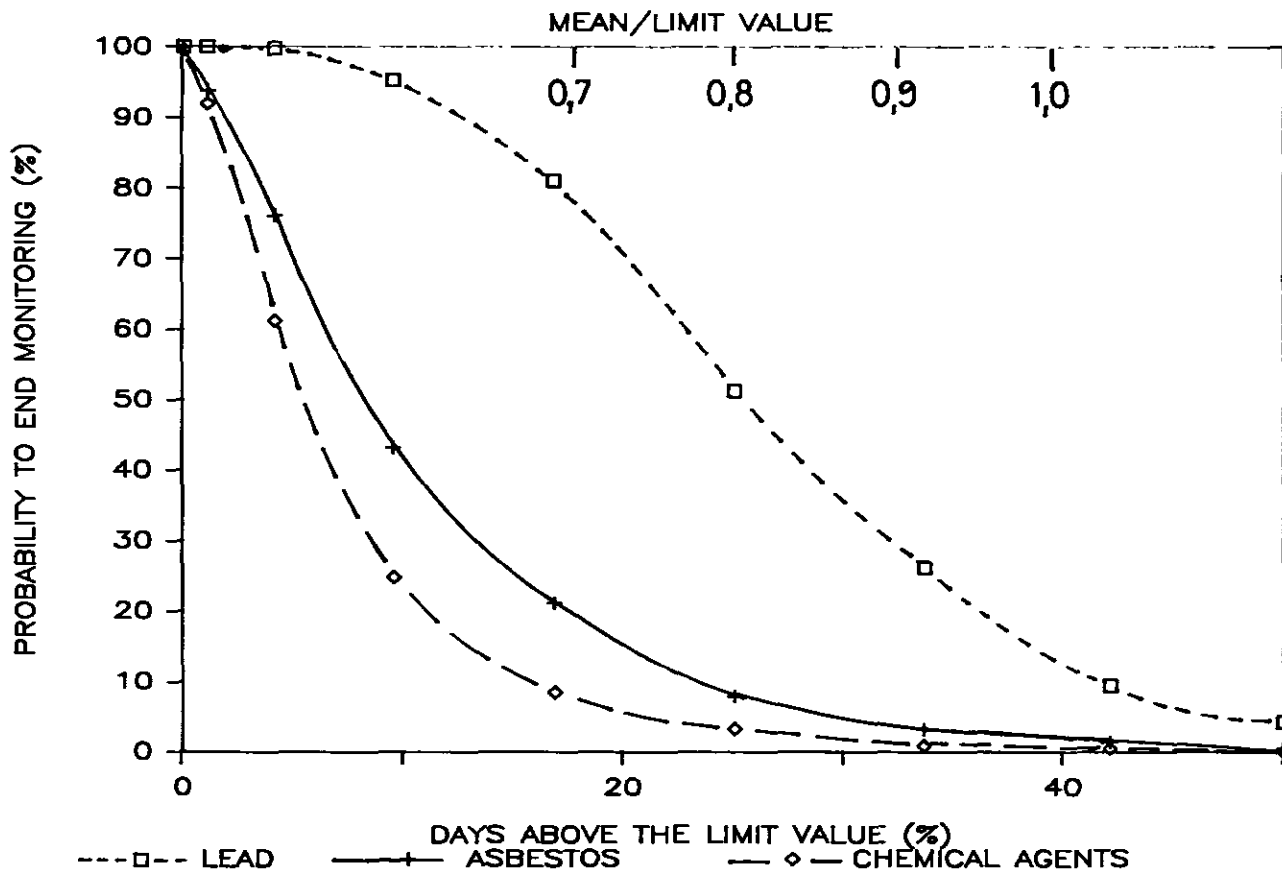

Figure 6. Operating characteristics.

value, whereas the chronic hazard is related to the average level of exposure. Therefore, the Safety and Health Commission for the Mining and Other Extractive Industries of the European Community in its draft proposal on the worker's protection from the risk due to the fibrogenic mineral dust in the non-coal mines and quarries, allows the operator to choose between the asbestos monitoring scheme and the compensation method, this last one being more expensive but with lower operator risk.

REFERENCES

1. *Official Journal of the European Communities*, L 327:8-13 (03.12.80).
2. *Official Journal of the European Communities*, L 247:12-21 (23.08.82).
3. *Official Journal of the European Communities*, L 263:25-32 (24.09.83).

4. Pr at, B.: Application of Geostatistical Methods for Estimation of the Dispersion Variance of Occupational Exposures. *Am. Ind. Hyg. Assoc. J.* 48:877-884 (1987).
5. *Official Journal of the European Communities*, C 164:4-8 (02.07.86).
6. Rock, J.C.: A comparison between OSHA-compliance criteria and action-level decision criteria. *Am. Ind. Hyg. Assoc. J.* 43:297-313 (1982).
7. Armbruster, L., Robock, K., Neulinger, G., Fleckner, K.-D., Freisewinkel, U., Heiderich, R.: Weiterentwicklung der Feinstaubmessanlage und Betriebserfahrungen im Steinkohlenbergbau. *Ergebnisse von Untersuchungen auf dem Gebiet der Staub- und Silikosebek pfung im Steinkohlenbergbau*, Band 16, pp. 67-78. Steinkohlenbergbauverein, Essen, West Germany (1987).

ACKNOWLEDGEMENTS: The author wishes to thank K. ROBOCK and L. ARMBRUSTER of the Bergbau-Forschung GmbH, Hauptabteilung Staubbek pfung und Pneumokonioseverh tung (Essen, West Germany) for the provision of the data used for the study of the autocorrelation.

ANALYSIS OF RESPIRABLE COAL MINE DUST SAMPLES BY INFRARED SPECTROSCOPY

P. PAROBECK • S. Ainsworth • T. Tomb

Mine Safety and Health Administration, Pittsburgh, Pennsylvania, USA

ABSTRACT

To control the health hazard associated with quartz in the United States coal mining industry, Federal regulation requires that whenever the quartz content of the respirable dust in the coal mine environment exceeds five percent, the applicable respirable dust standard be reduced. This regulation, which is applicable for both surface and underground mining operations, has been in force since the promulgation of the Federal Coal Mine Health and Safety Act in 1969. To enforce this regulation, the Mine Safety and Health Administration (MSHA) analyzes approximately 6,000 respirable coal mine dust samples per year for quartz content. The quartz content of these samples is determined using an infrared spectroscopic method.

This paper presents an overview of MSHA's quartz enforcement program, the analytical method used for quartz determination and efforts underway to enhance the sensitivity of the method.

INTRODUCTION

At the time of promulgation of the Coal Mine Health and Safety Act of 1969, the Congress of the United States of America stipulated that a limit be placed on the allowable quantity of quartz to which miners would be exposed. The requirement for this limit was based on work performed in the 1930's and 1940's^{1,2} which showed that the presence of quartz increased the health hazard associated with exposure to coal dust. Based on this data, the United States Bureau of Mines in 1948 established a dust exposure limit when the dust in the environment was found to contain more than five percent quartz. The limit at that time, determined by multiplying the dust particle concentration by the percent quartz, was not to exceed five million particles per cubic foot of air.

When the United States Congress promulgated the Coal Mine Health and Safety Act in 1969, they directed that a formula be developed for lowering the applicable respirable dust standard when the quartz content of the dust to which miners are exposed is greater than five percent. Such a formula was developed on March 10, 1971, and was included in Parts 70.101, 71.101 and 90.101 of Title 30 of the Code of Federal Regulations. According to the formula, the applicable dust standard (mg/m^3) is determined by dividing the percent quartz into the number 10 (i.e., standard = 10/% quartz). This formula was continued under the Federal Mine Safety and Health Act of 1977 which amended the 1969 Act.

To enforce this standard, the quartz content of respirable coal mine dust samples is determined by the use of infrared absorption spectrophotometry. Three common methods available for the analysis of crystalline silica are the use of X-ray diffraction, visible absorption spectrophotometry and infrared absorption spectrophotometry. The advantage of using the in-

frared method over the others for the analysis of coal mine dust samples is that the sensitivity is greater than either that of the X-ray Diffraction Method³ or the visible absorption spectrophotometric method, also referred to as the Talvite method.^{4,5} In addition, the X-ray method, although able to differentiate between different forms of free silica (quartz, cristobalite and tridymite), is affected by several compounds which have diffraction peaks that interfere with the major peak for quartz. The Talvite method, which cannot distinguish between the crystalline forms, requires extensive sample preparation using various corrosive acids and is a time consuming procedure.

Since cristobalite, tridymite and amorphous silica, all of which would cause an interference in the infrared analysis for quartz, have not been detected in coal mine dust,³ the infrared method is ideal for the determination of quartz in coal mine dust samples. From 1970 through 1980, quartz analysis was conducted by MSHA using a high temperature ashing (800°C) technique and the subsequent pelletizing of the ash with potassium bromide (KBr). This procedure required a sample mass of one to four milligrams, thus requiring the compositing (combining) of a number of samples from various coal mine operations to obtain a sample of sufficient weight for analysis.⁶ In 1981, the method was upgraded to the current method which is known as the Low Temperature Ashing (LTA) Method. This LTA method allows for the analysis of individual coal mine dust samples containing from 0.5 to 2.5 mg of dust. The method, developed by the Bureau of Mines, has been ruggedized and evaluated.³

From 1970 through December of 1985, enforcement of the quartz standard in the United States was determined solely from the analysis of a single sample or composited samples collected by Federal mine inspectors. In December of 1985,

MSHA's enforcement policy was revised so that the quartz content of the dust in the environment is based on a number of samples (up to three) collected over a period of several months and includes samples collected by the coal mine operators.

QUARTZ ENFORCEMENT PROCEDURE

The rudiments of MSHA's current quartz enforcement program require the analysis of selected respirable dust samples collected by mine inspectors during the approval or verification of mine operators' dust control plans. Samples typically selected for analysis are those collected on the designated occupation (DO), that occupation in an underground mining operation that has the highest respirable dust exposure, the roof bolting (RB) operation in underground mining and designated work positions (DWP) in the surface coal mining industry. If the analysis of any of these samples shows that the quartz content is in excess of five percent, the mine operator is notified of the option of collecting a sample for analysis on the mine entity representative of the original sample which was in excess of five percent quartz. If the difference between the quartz percentage of the operator's sample and the quartz percentage of the MSHA sample is within plus or minus two percent, (e.g., MSHA value seven percent, operator value five to nine percent) the results of the two analyses are averaged and the respirable dust standard is set accordingly. If the quartz determination of the operator's optional sample differs from the MSHA sample by more than plus or minus two percent, the operator is given the option of collecting a second sample on the mine entity. Following analysis of the operator's second sample, the average quartz percentage is determined from the three samples (MSHA sample plus the two samples submitted by the operator). If the operator elects not to collect a sample or if the samples submitted have insufficient dust for analysis (less than 0.5 milligrams), the standard is adjusted based on the analysis of the MSHA sample. At six month intervals, any entity on a reduced standard is automatically reevaluated by analyzing for quartz one of the mine operator's samples submitted for dust compliance, provided there is sufficient weight gain on the sample. Analysis of MSHA inspector samples, mine operator optional samples and six month operator samples accounts for the analysis of approximately 6,000 samples per year.

ANALYTICAL METHOD

Analysis of respirable coal mine dust samples for quartz is conducted in a central laboratory located in Pittsburgh, Pennsylvania. The operation of this laboratory is a function of MSHA's Pittsburgh Health Technology Center. The analytical method used for the analysis employs the principle of infrared spectrophotometry. The current LTA method allows for the analysis of the quartz content of a sample with a mass of 0.5 milligrams or greater. The method has a detection limit of 10 micrograms of quartz and a precision of 13 to 22 percent for quartz masses ranging from 25 to 160 micrograms.³

Samples are collected with approved respirable coal mine dust sampling assemblies equipped with a quartz-free, ashable

filter medium. Following weighing of the filter to determine sample mass, the filter medium is ashed in a low-temperature ashing system. This ashing system, shown in Figure 1, operates at a temperature of approximately 120°C and utilizes radio frequency energy to generate an oxygen plasma which destroys the filter matrix and the carbonaceous material present in the sample.

Following ashing, isopropyl alcohol is added to the residue. The residue is dispersed in the alcohol using an ultrasonic generator. The suspension is filtered onto one half of a Gelman DM-450 vinyl metricel filter. The filtering is accomplished by washing the sample through a specially constructed, glass filter funnel on a vacuum manifold system, shown on Figure 2. The funnel is designed to produce a 10 millimeter diameter deposit. Once filtration is complete, the filters containing the ashed deposits are dried on a slide warmer for approximately 20 minutes at a temperature of approximately 42°C.

Analysis for quartz is then conducted using a dispersive infrared spectrophotometer. The DM-450 filter half containing the ashed residue is mounted in a sample holder and placed in the sample beam of the infrared spectrophotometer. A blank DM-450 filter half which has been treated with alcohol and dried is similarly mounted in the reference beam of the instrument. Following appropriate parameter setting of the infrared instrument, the sample is scanned in the absorbance mode from 1,000 to 710 cm^{-1} . Quartz absorbs infrared energy in the 800 cm^{-1} region. The clay mineral kaolinite, which is also found in coal mine dust, also absorbs infrared energy in this region.³ Its presence causes a slight overestimation of the quartz content. To correct for this overestimation, the absorption for kaolinite is measured at 915 cm^{-1} . Thus, measuring the absorbance of infrared energy by the sample from 1,000 to 710 cm^{-1} allows for the quantification of kaolinite at 915 cm^{-1} and the correction for its interference with quartz absorbance at 800 cm^{-1} .

Figure 3 shows a sample of an infrared scan of a typical coal mine dust sample. As illustrated on the figure, the peak intensities at 915 and 800 cm^{-1} are determined by measuring the height from established baselines to the peak maximums. The baselines are drawn from 950 to 890 cm^{-1} for the 915 cm^{-1} kaolinite band and from 810 to 760 cm^{-1} for the 800 cm^{-1} quartz-kaolinite band. The measured net peak heights are converted into absorbance units and the interference due to kaolinite is determined from a calibration curve of kaolinite absorbance at 915 cm^{-1} versus kaolinite absorbance at 800 cm^{-1} . The calculated absorbance for kaolinite at 800 cm^{-1} is subtracted from the measured absorbance at 800 cm^{-1} (quartz-kaolinite) to give the absorbance due to quartz. The amount of quartz is determined from a calibration curve of absorbance of quartz at 800 cm^{-1} versus mass of quartz.

For MSHA's quartz enforcement program, -5 μm Minusil, a commercial product of the Pennsylvania Glass Sand Company, Berkeley Springs, West Virginia, is used as the quartz standard.⁷ Kaolinite used for the standard is Hydrite UF, supplied by the Georgia Kaolin Company, Elizabeth, New Jersey.

Once the analysis and calculations are completed, the percent quartz in the coal mine dust sample is computed by using the

following equation:

$$\text{quartz (percent)} = \frac{\text{mass of quartz (}\sigma\text{g)}}{\text{mass of coal mine respirable dust (}\sigma\text{g)}} \times 100$$

The percent quartz determined for a coal mine dust sample is truncated to the whole percent value which is subsequently used in the formula for the determination of the reduced coal mine dust standard when the quartz percentage is in excess of five percent (reduced standard = 10/% quartz).

To insure the integrity of the quartz analyses performed, MSHA conducts an internal quality assurance program. This program consists of the analysis of three specially prepared samples, containing varying known quantities of quartz, with each group of 20 to 25 samples analyzed. The mass of quartz on each of the three quality control samples is unknown to the analysts. These samples undergo the same processing as the coal mine dust samples; i.e., ashing, deposition by filtration and IR scanning. The analysis of these samples is used to verify that the process is controlled, assuring the reliability of analytical results.

IMPROVEMENTS TO ANALYTICAL CAPABILITY

In an effort to improve the sensitivity of the present analytical technique, MSHA recently acquired a Fourier transform infrared spectrophotometer (FTIR). A FTIR operates different-

ly than a dispersive infrared spectrophotometer. A FTIR employs an interferometer to obtain information about the transmission of infrared energy of all wavelengths (simultaneously) emitted by the source and passing through the sample, whereas a dispersive spectrophotometer uses a monochromator and slit system to divide the infrared radiation into frequency elements. The interferometer of the FTIR contains a fixed mirror and a moving mirror, the position of which is determined by a helium-neon laser. The information obtained from a sample is digitally stored as signal intensity versus mirror displacement as shown in Figure 4. This is known as an interferogram. The instrument's computer then performs a Fourier transform of the interferogram to produce the desired absorbance versus frequency (in wave numbers) spectrum as shown in Figure 5.

The FTIR has many advantages over the dispersive instrument. Since there are no entrance or exit slits in the FTIR, a greater amount of energy reaches the detector, resulting in increased sensitivity. The laser tracking of the moving mirror results in greater precision of the wavelength measurement, permitting multiple scans to be averaged and thereby increase the signal to noise ratio of the absorbance spectrum. Precise duplication of the analytical frequencies and computer control of the calculations with the FTIR reduce the errors associated with the electromechanical components of the dispersive instruments and the necessary manual measurements of frequencies and peak intensities.



Figure 1. Low-Temperature ashing system.



Figure 2. Vacuum filtration of ashed samples.

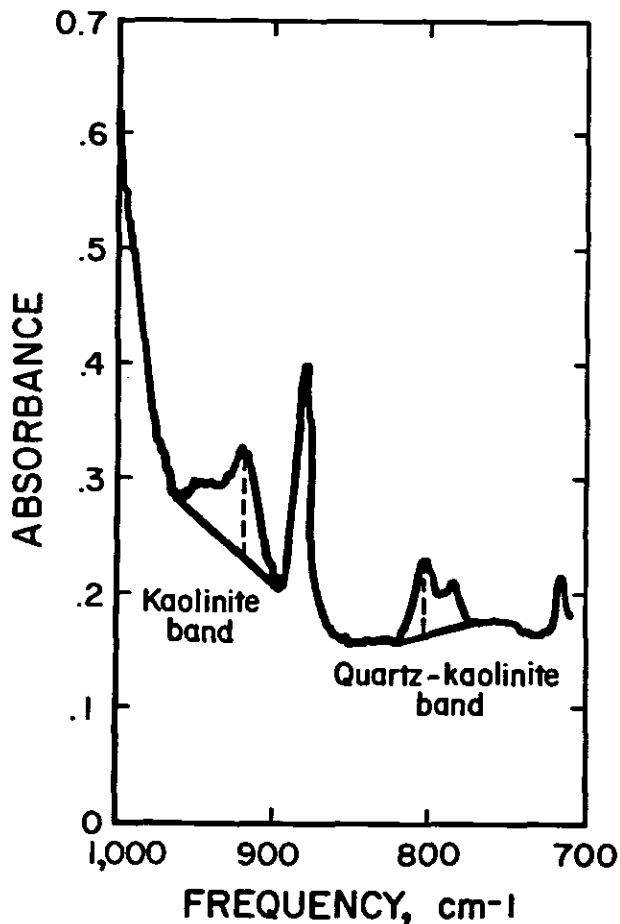

Figure 3. Infrared scan on dispersive IR of a coal mine dust sample showing manually drawn baselines and peak locations.

The current quartz analysis procedure employing dispersive IR is used to detect from 25 to 250 micrograms of quartz for coal dust sample masses ranging from 0.5 to 2.5 milligrams. With the FTIR, it is anticipated that 10 micrograms of quartz will be detectable in coal dust samples with as little mass as 0.2 milligrams. This factor is of considerable importance since many respirable coal mine dust samples obtained in the surface coal mining industry are of low mass, yet have greater than five percent of quartz. This system should allow for the analysis of such samples. The computerization of the data handling will, likewise, automate output and eliminate tedious and redundant tasks which are currently performed manually.

SUMMARY

The United States Congress realized the hazard associated with coal miners' exposure to quartz and, when issuing the Coal Mine Health and Safety Act of 1969 and the subsequent Coal Mine Safety and Health Act of 1977, stipulated that exposure to quartz be controlled. Exposure to quartz is controlled by reducing the applicable dust standard when the dust is found to contain quartz levels in excess of five percent.

To determine the quartz content of respirable coal mine dust, MSHA utilizes an infrared spectrophotometer to measure the absorbance of infrared energy by quartz in a dust sample. This analysis is conducted following the destruction of the combined sample and filter matrix by a low temperature ashing process and subsequent filter redeposition of the ash containing the quartz. Since the mineral kaolinite interferes with the quartz determination, a correction is made to the result obtained.

In order to automate the processing of samples and obtain a lower level of detection, the use of a FTIR to analyze coal

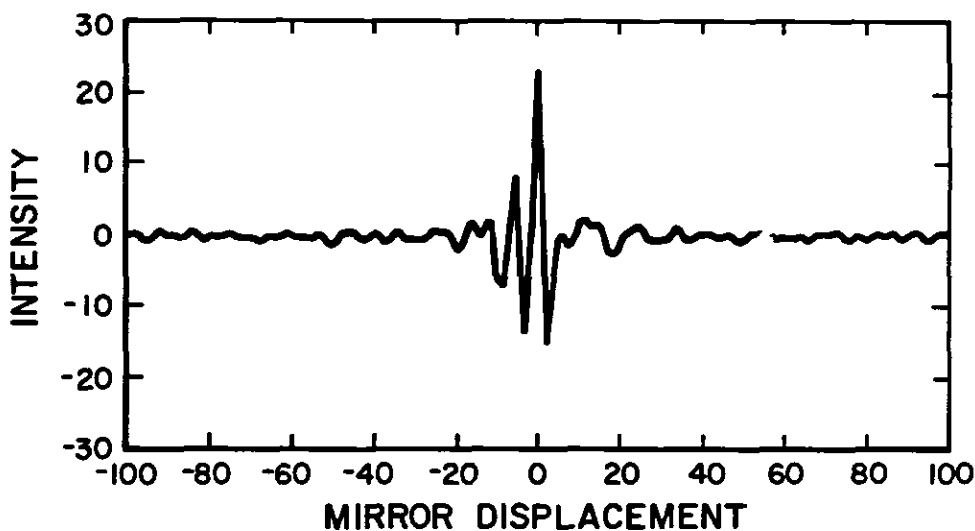

Figure 4. Interferogram of a pure quartz sample.

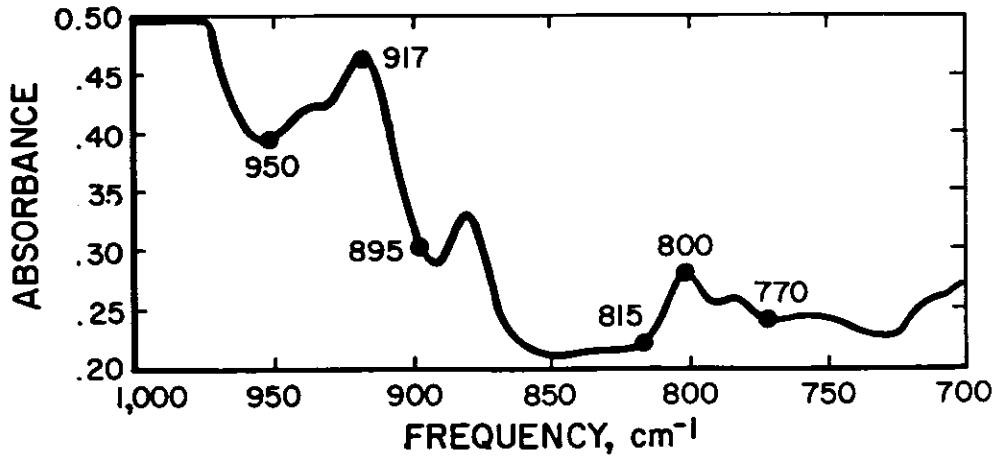

Figure 5. Absorbance spectrum from FTIR of a coal mine dust sample with kaolinite and quartz-kaolinite frequencies indicated.

mine dust for quartz content is being investigated. It is anticipated that a quartz mass of 10 micrograms will be detectable in respirable dust samples with masses as small as 0.2 milligrams.

REFERENCES

1. Bloomfield, J.J., et al: Anthraco-Silicosis Among Hard Coal Mines. *US Public Health Service Bulletin 221*, pp 118 (1935).
2. Flinn, R.H., Siefert, J.E., Brinton, H.E., Jones, J.L., Franke, R.W.: Soft Coal Miners Health and Working Environment. *US Public Health Service Bulletin 270* (1941).
3. Anderson, C.C.: Collaborative Tests of Two Methods for Determining Free Silica in Airborne Dust. *DHHS (NIOSH) Publication No. 83-124*, Contract No. 210-79-0059 (1983).
4. Talvite, N.A.: Determination of Quartz in Presence of Silicates Using Phosphoric Acid. *Analytical Chemistry* 23:623 (1951).
5. Talvite, N.A., Hyslop, F.: Colorimetric Determination of Siliceous Atmospheric Contaminants. *Am. Ind. Hyg. Assoc. J.* 19:54-58 (1958).
6. Goldberg, S.A., Raymond, L.D., Taylor, C.D.: Bureau of Mines Procedures for Analysis of Respirable Dust from Coal Mines. *Am. Ind. Hyg. Assoc. J.* 34:200-205 (1973).
7. Kacsmar, P.M., Tomb, T.F.: Comparison of Alpha Quartz Materials Used as Calibration Standards. *Coal Mine Dust Conference Proceedings*, Morgantown (1984).

EFFECT OF THE MEASURING STRATEGY ON THE DETERMINATION OF THE RESPIRABLE DUST CONCENTRATION IN THE BREATHABLE AIR AT UNDERGROUND WORKPLACES

BERNARD PRINZ, Dipl.-Ing. TH • R. Stolz • Ruhrkohle AG, Essen, FRG

INTRODUCTION

The dust conditions at the underground workplaces are permanently discussed worldwide. These discussions are always based on the absolute values of the respirable dust concentrations in the breathable air indicated in mg/m^3 (Figure 1). They provide information on the effective limits for the permissible respirable dust concentrations and on the results of the statutory dust measurements. These values are also used to reflect the state of the pneumoconiosis prevention and dust suppression in the various hardcoal mining countries.

In the following it is intended to show that the respective indicated absolute values are not suitable for a comparison of the dust load of miners in different countries, the reason for this being that the rules for the determination of the values, i.e. the measuring strategies, are not included in the discussions. The existing different measuring strategies have, however, significant effects on the magnitude of the measured absolute values. Thus, there is no uniform basis for an objective comparison. The measuring results are significantly influenced by the following parameters of the measuring strategy:

- the position of the measuring point;
- the time required for an individual measurement; and
- the frequency of the measurements.

Measuring Strategy in Different Countries

According to the measuring strategy effective in the Federal Republic of Germany (FRG) (Figure 2) since 1954 the respirable dust concentration has to be measured at the location of a working area at which the maximum dust concentration has to be expected. In this context it is generally assumed that in working faces this location is situated, seen in ventilation direction, at the face end respectively the end of the working area. Measurements are taken once a month under normal operating conditions. The measurement period corresponds to the time the miners stay at their workplaces. Over a period of five years each the preset limits for the dust exposition of the miners must not be exceeded. Higher individual shift values which have to be compensated over the 5 year period are, however, permissible.

The measuring strategy in the FRG is based on the following considerations:

1. For the people employed in the environment of the measuring point, the measuring result is sufficiently accurate.

2. The impact of dust on people employed on the intake side upstream the measuring point is overrated by the "high risk method."
3. By overrating higher urgency is attributed to the measures for a prevention of dust impact on the employees.
4. One monthly measurement over a 5 year period is sufficient as the dust load of each miner is determined with sufficient accuracy by 60 measurements in five years.

In Great Britain (GB) measuring values of a fixed measuring point located in the return airway approx. 70 m behind the face are used to assess the dust conditions at the workplaces in the face. The fact that it is only there that the measuring results are no longer influenced by the coarse dust or the unequal distribution of the respirable dust in the air is given as a reason for the choice of this location. The partial sedimentation of the dust between the face and the measuring point is considered by correction factors. Measurements are taken in monthly intervals. As in the FRG the time of a measurement corresponds to the time the miners stay at the workplace. The number of measurements in one month depends on the size of the measured individual fine dust concentration. At values $< 15 \text{ mg}/\text{m}^3$ one measurement per month is sufficient. At values $> 8 \text{ mg}/\text{m}^3$ the average has to be calculated from up to five subsequent measurements in one week.

The main point in the measuring strategy of the Soviet Union (USSR) is the monitoring of dust suppression in the face. When cutting coal with shearers the air-borne dust concentration with grain sizes of up to $74 \mu\text{m}$ without preseparator is determined directly behind the shearer, when ploughing the coal it is determined at the face end. The strategy for these dust measurements has the main objective to improve the efficiency of dust suppression measures. The measuring time per measurement amounts to a few minutes during the coalgetting process. The measurement is repeated in monthly intervals if the measuring result shows a value $\leq 10 \text{ mg}/\text{m}^3$. At higher values the measurement is repeated directly after improving dust suppression.

The measuring strategy in the United States of America provides for a measurement of the acting respirable dust concentration by means of "personal dust samplers" directly at the employee. For the measurement the person exposed to the highest dust load in the face may be chosen as representative for all employees of one face. This measuring method called "designated occupation" is also based on the "high risk"

	Tolerable Dust Concentration mg/m ³	Dust Fraction	Quartz Valuation
RUHR	8.0	respirable	yes
SAAB	4.0	respirable	no
USA	2.0	respirable	yes
GB	5.0	respirable	no
USSR	2.0	inhalable	yes

 Ruhrkohle AG	Limit Values for Dust in Coal Mines	Arbeits-schutz
--	-------------------------------------	----------------

Figure 1.

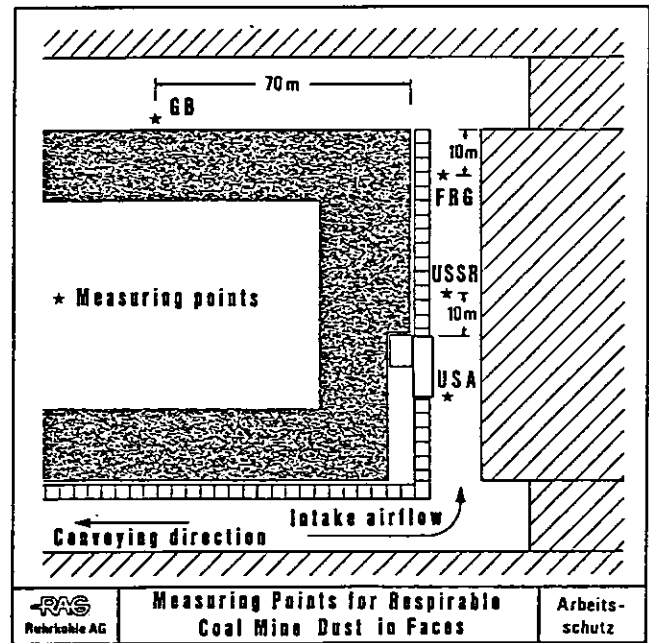

Figure 2.

process as the measuring strategy in the FRG. In faces the workplace of the shearer operator is mainly chosen as "designated occupation." This is justified if nobody is employed behind the shearer for more than two hours during the shift.

The respirable dust concentration at the workplace or the measuring point is assessed in two-monthly intervals by the average of 5 measurements taken in 5 subsequent production shifts. If the limit is exceeded additional measurements have to be carried out in the following production shifts and a new average has to be calculated from 5 subsequent measuring values. The measuring series is interrupted if one average reaches or remains below the limit. The measuring time of each individual measurement corresponds to the shift length, i.e. working time plus travelling time.

The effect of the measuring strategy on the size of the measuring values can be illustrated by means of an example for respirable dust measurements in 10 faces of Ruhrkohle AG (Figure 3).

In each of these faces several measuring points were installed in regular intervals. The respirable dust concentration was measured over a longer time period in the first production shift of each day with the miners at their workplaces. In the diagram the monthly averages of the respirable dust concentrations in mg/m³ are listed on the ordinate, the face length in % on the abscissa.

At the face entry, i.e. at face meter "0", the respirable dust concentration in the intake air of the face was listed.

In nine of the ten faces the respirable dust concentrations increase in different magnitudes towards the face end where they

reached their highest values. The different increase is governed by work sequence, machine type, support, ventilation volume, ventilation velocity, etc. In one case—i.e. face 8—in contrast, the initial concentration is already so high that the sedimentation over the face length is higher than the concentration increase caused by the coalgetting operations.

According to the measuring strategy of the USA all employees in the face would be exposed to the dust concentrations of the intake air flow, i.e., the initial values of the graphs on the extreme left of the diagram, under the prerequisite that:

1. The shearer operator stands on the intake air side in front of the machine;
2. The dust produced by coalgetting is blown away from the site of the shearer operator; and
3. Bypasses the chock fitters.

A possible slight increase in the dust concentrations in the intake air flow towards the workplace of the operator by turbulences is negligible in this approach.

Applying the German measuring strategy these values are contrasted by the concentrations of the fixed measuring points which in contrast to the USA are, however, located at the face end. This means (Figure 4) that in a comparison of the values up to 9 times higher values have to be assigned to the employees due to the German measuring strategy with the measuring point at the face end compared to the American strategy. Even in case of a subdivision of the face into two monitoring sections with measuring points in the center and at the end of the face up to 6 times higher values are still calculated for the employees in the lower face section according to the German measuring strategy. On average the concentrations at the face entry and the face end differ by the

factor 3.9 and the concentrations at the face entry and the face center still by the factor 2.4.

The determination of the measuring values in Great Britain is again significantly different from the determination of the measuring values in the USA and the FRG. On the one hand additional dust sources between the face and the measuring point are registered, on the other the measuring result is corrected by a factor for sedimentation which was developed specifically for British mines. It may, however, hardly be applied worldwide.

CONCLUSION

From the mentioned comparison it may be derived that both the dust limits and the absolute respirable dust concentration figures cannot be referred to in a comparative representation of the dust conditions in different countries.

Also the dust suppression measures applied in the different countries have to be seen under this aspect. The measuring strategies of the FRG, GB and the USSR call for measures reducing the dust concentration in the entire return air section. In the United States dust suppression may center on the intake air section up to the coalgetting machine (Figure 5). This becomes particularly clear in the "shearer clearer" process. The dust produced by the coalgetting operations is kept away from the measuring point. Without doubt this process has the advantage of reducing the dust load for machine operators and chock fitters.

Face No.	USA / FRG Head - Tail	USA / FRG Head - Centre
1	1 : 2.1	1 : 1.6
2	1 : 5.4	1 : 2.8
3	1 : 2.7	1 : 1.7
4	1 : 4.3	1 : 2.0
5	1 : 6.0	1 : 3.1
6	1 : 3.1	1 : 1.8
7	1 : 8.8	1 : 6.0
8	1 : 0.7	1 : 0.8
9	1 : 2.3	1 : 1.9
10	1 : 3.4	1 : 2.3
	\bar{x} 1 : 3.9	\bar{x} 1 : 2.4
<div style="display: flex; justify-content: space-between; align-items: center;"> <div style="text-align: left; font-size: small;">  <p>RAS Rohrbach AG</p> </div> <div style="text-align: center; font-weight: bold; font-size: small;"> Factor of Respirable Coal Mine Dust in Faces: USA / FRG </div> <div style="text-align: right; font-size: small;"> <p>Arbeits- schutz</p> </div> </div>		

Figure 4.

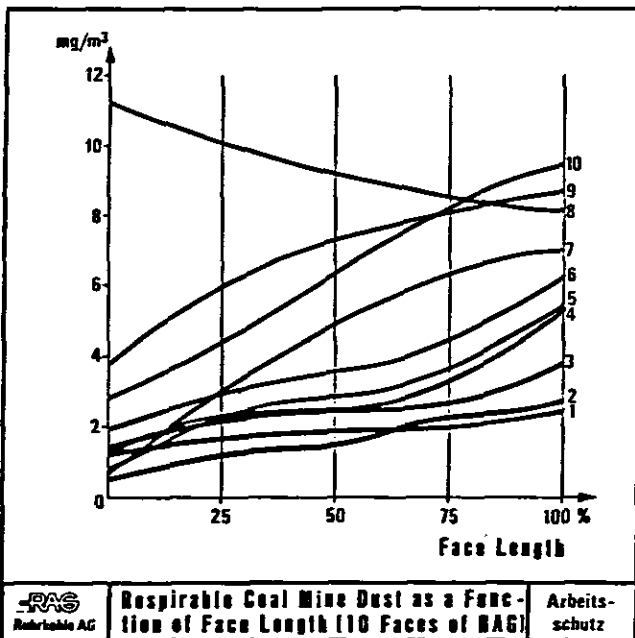

Figure 3.

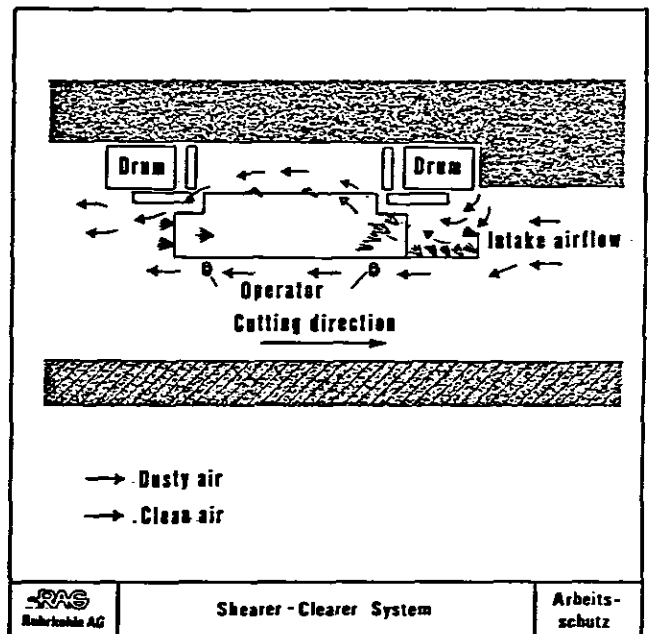

Figure 5.

These comments were intended to show that:

1. The different measuring strategies will inevitably have to result indifferent limits;
2. The measuring values and limits determined by one measuring strategy can only be compared in its scope of validity;
3. Identical absolute values of the different countries do not describe also identical dust conditions or dust impact;
4. Limits provide for a statement on the pneumoconiosis risk of the employees only in their scope of validity.

The comments of Dr. Bauer (FRG) on the impact of different measuring devices, tyndallometer, cycloneseparator, horizontal elutriator, on the result of respirable dust measurements underline the mentioned reservations against a comparison of measuring values and limits.

These comments are not intended to be an assessing state-

ment on the measuring strategies but are only meant to explain the fact that measuring values and limits cannot be compared as long as they are based on different measuring strategies.

The uncritical comparison of measuring values and limits from different measuring strategy scopes involves two dangers:

1. That a race towards actually desirable but technically not feasible limits is started; and
2. That the statement on the pneumoconiosis risk of a mining region in relation to the dust impact is wrong if risk determinations are taken over from other measuring strategy scopes.

For an international comparison of the dust load to which the miners in the hardcoal mines are exposed, it is thus required to use identical reference measuring equipment and to apply an identical reference measurement strategy.

RESPIRABLE DUST AND FREE SILICA VARIATION IN MINE ENVIRONMENTS

THOMAS A. HALL,* M.H.S. • Morton Corn,* Ph.D. • S. Zeger,† Ph.D. •
C.C. Law,† M.S.

*Division of Environmental Health Engineering, Department of Environmental Health Sciences,
School of Hygiene and Public Health, Johns Hopkins University, 615 N. Wolfe Street,
Baltimore, MD 21205, USA

†Department of Biostatistics, School of Hygiene and Public Health, Johns Hopkins University,
615 N. Wolfe Street, Baltimore, MD 21205, USA

Regulations promulgated and enforced by the Mine Safety and Health Administration (MSHA) require that coal mine operators control respirable mine dust to prescribed concentrations.⁵ Specifically, coal mine operators must regularly sample (bimonthly) respirable mine dust (RMD) in working mine sections. MSHA on a less frequent basis (once a year) also samples and evaluates RMD and its free silica (FS) content in working coal mines. Sampling is performed by MSHA and mine operators in order to: 1) establish permissible RMD levels in working mine sections when free silica is present; and 2) demonstrate compliance with permissible exposure limits prescribed in regulations. In non-coal mines the sampling frequency is less well defined.

Since passage of the Coal Mine Safety and Health Act of 1969 and the Mine Safety and Health Act of 1977, enormous resources have been focused on controlling RMD in mines with highly satisfactory results. The vast majority of U.S. coal and non-coal mines consistently meet the appropriate RMD Permissible Exposure Limits (see Formula 1) promulgated by MSHA.¹²

In the past five years, more inspector RMD samples have been analyzed for free silica. This has occurred because the analytical technique MSHA uses for the detection of free silica in coal mine dust has been refined and improved resulting in lower detection limits. The use of the "improved" analytical technique has suggested to many that MSHA has placed increased emphasis on enforcement of the coal mine respirable dust (containing free silica) standard. The standard for respirable dusts containing free silica used in coal mines invokes a "sliding scale" to determine the allowable RMD concentration. For % FS concentrations >5, Formula 1 is used to calculate the permissible RMD concentrations in coal mines.

$$\text{RMD, mg/M}^3 = \frac{10}{\% \text{ FS}} \quad (1)$$

(for % FS >5)

The purpose of this investigation was to gain insight into the extent of FS variation in RMD samples collected from a sample of U.S. coal and non-coal mines. A second goal of this study was to determine the factors (mining operation variables, etc.) associated with this variation. Specifically, the

following questions were addressed:

- How large is the sampling and laboratory error in measurements of respirable mine dust concentration (RMD), free silica (FS) and percent free silica (% FS)?
- Is the sampling and laboratory variability different in personal and machine samples, across occupations or mines?
- Is exposure to RMD and FS systematically different across occupations or mines?
- How large is the temporal variability in RMD, FS and % FS?

Thirteen mines, seven coal and six non-coal mines initially offered opportunities for dust sampling in this study. Of the thirteen mines originally volunteering for the investigation, ten (six coal and four non-coal) provided samples for analysis. Each participating mine was required to collect six air samples per day for five consecutive days. The six daily air samples were divided among five occupations with one miner wearing two samplers (paired sample). A total of 374 personal and area samples were collected in the participating mines during 55 sampling days.

Mine dust technicians from the participating companies were used to collect the air samples. Before these individuals were allowed to take part in the investigation they had to participate in a workshop presented by the study authors. Additionally, each participating mine was subjected to a site visit during the sample collection period to insure that the prescribed techniques for sample collection were being used. After collection all dust samples were forwarded to, and analyzed by an independent, accredited laboratory. Results of laboratory analyses of samples were transmitted to JHU for statistical analyses and interpretation of results.

All samples were collected using Mine Safety and Health Administration (MSHA) prescribed procedures with some minor modifications. The samples were analyzed at two commercial laboratories for respirable dust and free silica using the P7 analysis routine. The onsite dust technician or industrial hygienist responsible for sampling completed a standardized questionnaire. Data from questionnaires were analyzed by JHU investigators, as were the analytical results of dust samples.

LITERATURE REVIEW

The Mine Safety and Health Administration requires that coal mine operators conduct extensive sampling for respirable mine dust and airborne free silica. The goal of this sampling is to measure progress toward achieving promulgated dust standards and thus reduce the occurrence of pulmonary disease among the mining population. MSHA's strategy for controlling exposure to pneumoconiosis-producing dusts employs a sampling scheme which utilizes a worst-case scenario.

Although there is extensive scientific and technical literature which addresses the variability of measured mine dust concentrations resulting from the dust sampling process, few studies have sought to define the variability associated with sampling for respirable dust and its free silica content in mine environments. Factors affecting variability of airborne free silica dust, such as occupation, production rates, equipment operating time, and other mine and production variables have not been examined.

The most widely publicized investigation of measured dust concentration variability is a GAO report to Congress.⁶ In this report, the GAO indicated that under certain conditions the error associated with respirable mine dust samples could be as great as 50%.

An investigation by the Bureau of Standards studied respirable mine dust sampling and analysis.⁸ While focusing specifically on sampling and analysis (gravimetric) for respirable mine dust, each step in the sampling process was examined, e.g. dust weighing, pump flow variation, etc. It was concluded that under tightly controlled conditions with a "well-trained" technician, the average standard deviation associated with the process was $\pm 0.39 \text{ mg/M}^3$, or 19% (@ the 2 mg/M^3 RMD concentration).

In 1976, NIOSH found that in high risk mine sections (those which had been repeatedly found to be in violation of the 2 mg/M^3 standard) the coefficient of variation for RMD measurements was 91.6%.⁹

In 1980, the National Research Council concluded that uncertainties associated with spatial and temporal variation in RMD estimates from machine mounted samplers precluded this method for estimating personal exposures.¹⁰

In 1983, a literature review by investigators at the Johns Hopkins School of Hygiene and Public Health concluded that the factors responsible for the variation in RMD had not been quantitated for free silica and estimates of free silica were at least as unreliable as those of RMD.³ More specifically stated, "Because of the unavailability of data on free silica variation in coal mine respirable dust, the representativeness of a single sample analyzed for free silica can not be assessed." The authors went on to state that the use of a single air sample to determine free silica content of mine environments is meaningless.

Page and Jankowski compared RMD measurements made using a real-time aerosol monitor (RAM-1) and a standard gravimetric sampler at a longwall mining operation.¹¹ The authors reported ratios of paired RAM-Gravimetric sampler results, expressed as concentrations of RMD ratios of 0.41

to 1.63. The authors attributed this variation to differences in the aerosol cloud being sampled, air flow velocity at the filter face and cyclone orientation.

Burkhart, et al, in a presentation at the American Industrial Hygiene Conference in Dallas, Texas reported data from a limited number of air samples collected from bituminous coal mines in West Virginia.² The authors reported %FS concentrations ranging from 2 to 30% in five samples collected on five consecutive days. The samples reported were personal air samples collected on the operator of the continuous mining machine. The source of this variability was not discussed.

Breslin, et al, in a Bureau of Mines Circular reported that for both personal and fixed-point (area) samplers the coefficient of variation for RMD was typically less than 20%.¹

Kissell, et al, reviewed several factors thought to contribute to RMD and FS variability.⁷ The authors, while not specifically evaluating potential contributions to variation from mine sources, concluded that sampler position, geological variation in composition of coal, production factors such as deep or continuous cutting and failure to control known sources such as shuttle car loading, play an important role in RMD and FS sample results.

PAIRED SAMPLE ANALYSIS AND RESULTS

Sampling and laboratory variability for respirable mine dust, free silica and percent free silica were studied using 23 and 20 pairs of dust samples from coal and non-coal mines, respectively. Paired samples were defined for this study as two samples collected on the same occupation for the same time period and located not more than 14 inches apart. For this analysis, the ratios of the RMD and FS parameters were analyzed to determine variability. % FS was analyzed using the differences between the paired values. Figures 1-3 display the cumulative frequency distributions of RMD, FS and % FS, respectively. All three dust parameters exhibit large variability.

Results of this analysis are presented in Table I and are briefly summarized as follows:

Coal Mines

- The respirable mine dust *ratios* (larger to smaller values) exceeded 1.5 in half of the paired samples and 2.5 in 10% of the pairs.
- For free silica, 50% of the pair *ratios* exceeded 1.52; 10% exceeded 5.7.
- For % free silica, the *differences* (larger minus smaller) exceeded 1.3% in half of the pairs and 5.6% in one out of ten.

Non-Coal Mines

- The variability of respirable mine dust was somewhat less in non-coal mines with 50% of the samples having *ratios* greater than 1.13. 10% of samples demonstrated ratios of 6.19. (This was due to a few extreme outlier sample pairs.)

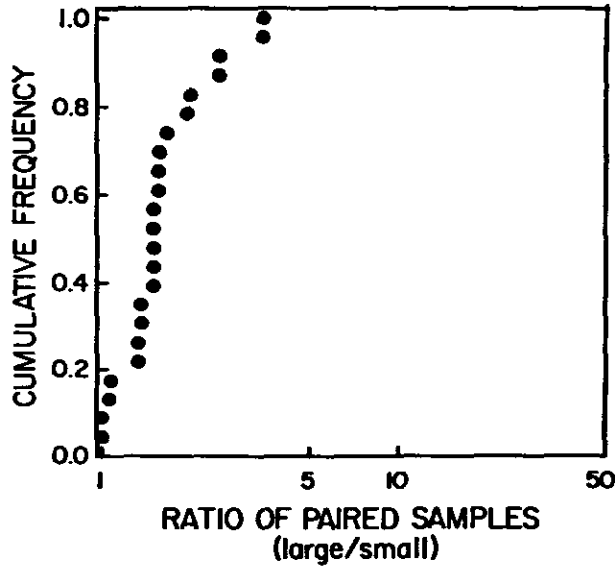

Figure 1. Cumulative distribution of RMD sample pair ratios.

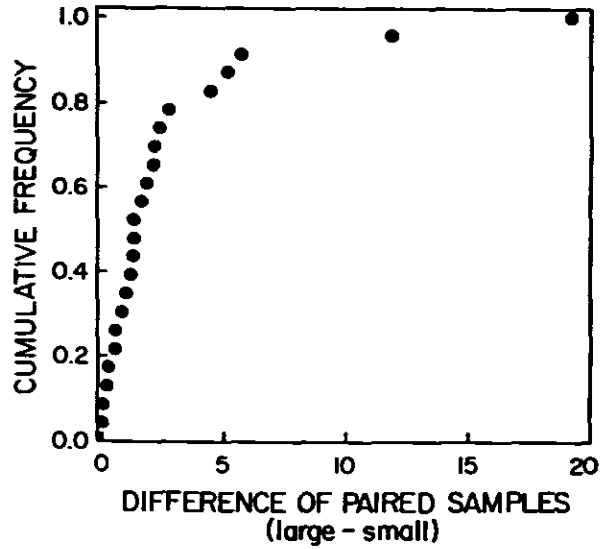

Figure 3. Cumulative distribution of % FS sample pair differences.

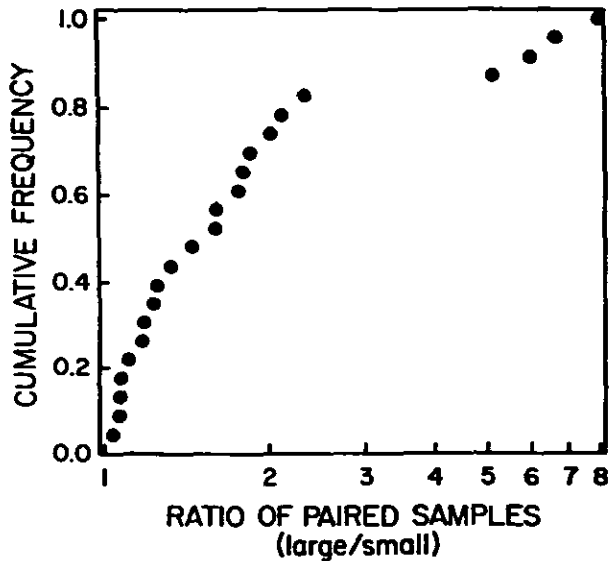

Figure 2. Cumulative distribution of FS sample pair ratios.

- For free silica, 50% of the respirable mine dust sample pair ratios exceeded 1.25 and 10% exceeded 2.0.
- The variability of % FS was slightly greater in non-coal mines. The differences in 50% of the samples were at least 1.7% free silica; 10% had differences equal to or greater than 7.7% free silica.

EFFECT OF INCREASED NUMBER OF SAMPLES ON VARIABILITY OF DUST PARAMETERS

The use of paired samples to measure variability in RMD, FS and % FS permits the prediction of variability reductions achievable by averaging increased numbers of samples. Figures 4 and 5 demonstrate the improvement in sample variability for the mean value of RMD and % FS. These figures were calculated from all paired samples and reflect the average variability improvement.

The achievement of a standard deviation of 0.2 (mg/m³) for respirable mine dust in coal and non-coal mines would require eight sample pairs. (Figure 4) In both coal and non-coal mines, a standard deviation of 1.5% free silica can be achieved with six sample pairs. (Figure 5)

Table I
Selected Cumulative Percentages of Coal and Hardrock Mine Dust Parameters

	Coal Mine			Hardrock Mine		
	<u>RMD</u>	<u>FS</u>	<u>%FS</u>	<u>RMD</u>	<u>FS</u>	<u>%FS</u>
	(ratio)		(diff.)	(ratio)		(diff.)
50 percentile	1.50	1.52	1.31	1.13	1.25	1.67
80 percentile	1.96	2.20	3.47	1.25	1.60	5.05
90 percentile	2.50	5.72	5.58	1.50	2.00	7.69
95 percentile	3.33	6.56	10.98	6.19	2.67	9.21
100 percentile	3.50	8.00	19.23	13.00	3.00	18.06

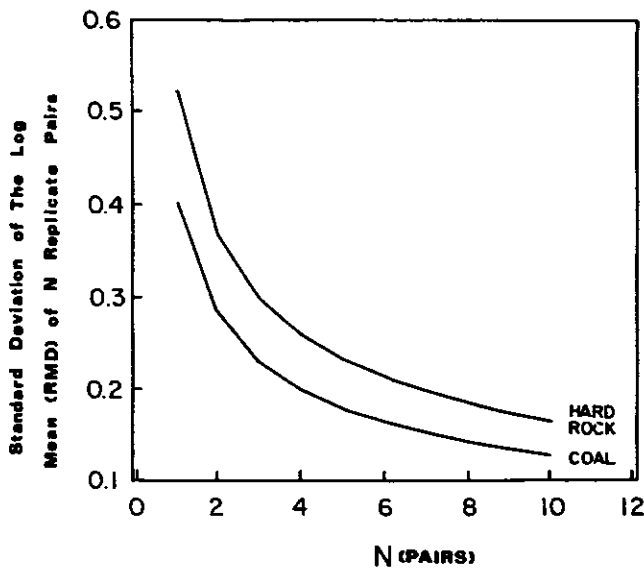

Figure 4. The effect of increased sample pairs on the variability of RMD estimates.

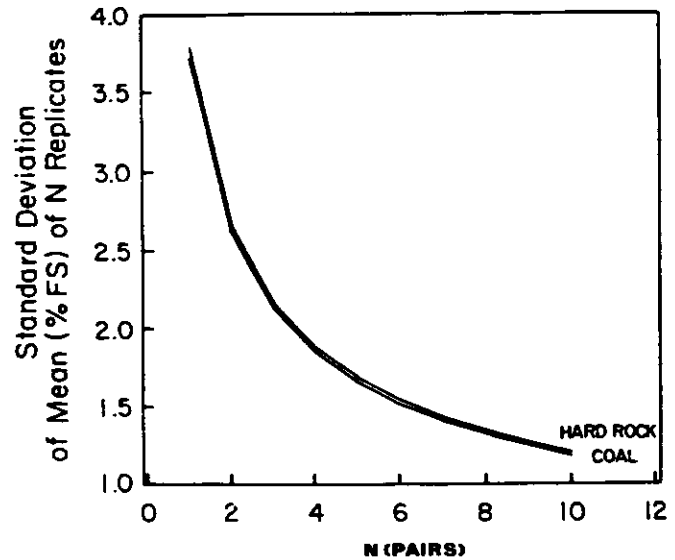

Figure 5. The effect of increased sample pairs on the variability of % FS estimates.

CONTRIBUTION OF STUDY PARAMETERS TO VARIATION

Linear regression analysis was used to determine the contribution to sample variability associated with study variables, i.e. production rate, sampler location, etc. The results demonstrate that for:

Coal Mines

- Sampler location was an important contribution to the demonstrated variability. Machine-mounted samples showed an improvement in variability for all measured

parameters. The improvement in variability for machine-mounted samples when compared with personal samples was 40%, 20% and 5% for RMD, FS and % FS, respectively. The improvement in % free silica variability associated with machine mounted samples was not statistically significant.

- Sample variability for respirable mine dust, free silica, and % free silica did not appear to be related to occupational category.
- Respirable mine dust exposure variability across mines was greater than within mine variability for occupation categories. Respirable mine dust, free silica and % free

silica are more dependent on production and/or dust control within the mine than on occupational category. Exposure to free silica demonstrated a consistent pattern, regardless of the respirable mine dust concentration in the mine. Roof bolters were exposed to respirable mine dust levels containing 2-3% more free silica than continuous miner or standard shuttle car operators, and approximately 5% more free silica than center or offside shuttle car operators.

Non-Coal Mines

Regression analysis of non-coal mine results could not be performed because of differences in mining methods employed by participants. These differences did not permit comparison of data between mines.

COMPARISONS OF EXPOSURES BY OCCUPATION

The analytical results of all dust samples were used to address the question of whether dust (RMD, FS and % FS) exposure differs across occupations within a mine, and whether there are differences in dust exposure within occupations across mines.

Because only coal mines have uniform job descriptions we have focused our analysis on coal mines. The geometric mean exposure and geometric standard deviation by occupation for coal mines are presented in Table II. Figures 6-8 display the mean exposures for the three variables RMD, FS, and % FS by job classification: mine operator, bolter (double boom), shuttle car operator-standard and shuttle car operator-center

Table II
Results of Air Sampling Analyses by Occupation and Mine for Coal Mines

Mine ID	N	Occupation Code ¹	RMD (GM ² , mg/M ³)	G.S.D. ³	FS (GM ² , mg/M ³)	G.S.D. ³	%FS (Mean)	S ⁴
2	8	1	1.67	1.58	0.045	1.41	2.95	1.45
	15	3	1.61	1.31	0.117	3.13	7.66	2.08
	6	4	2.52	1.86	0.054	2.97	1.93	0.89
	8	6	1.97	3.98	0.044	1.45	2.92	0.88
3	7	1	1.42	2.03	0.039	5.90	3.73	1.88
	12	3	1.12	1.74	0.048	1.69	6.41	3.15
	11	4	0.80	1.76	0.017	2.45	2.78	2.34
5	8	1	0.767	1.60	0.023	2.03	4.05	2.84
	12	3	0.620	1.09	0.033	2.03	5.56	1.34
	3	4	0.252	1.92	0.006	1.32	2.83	1.59
	9	6	0.268	2.36	0.010	1.77	4.42	3.82
7	7	1	0.580	2.46	0.121	3.11	27.7	25.7
	15	3	0.612	2.13	0.090	3.39	23.1	18.7
	5	4	0.261	1.44	0.050	1.48	21.5	12.1
	5	6	0.267	2.39	0.030	4.56	14.9	8.81
8	5	1	0.474	1.38	0.010	1.83	2.24	0.917
	12	3	0.975	1.98	0.047	1.85	5.04	1.59
	6	4	0.824	2.30	0.011	3.71	2.00	2.06
10	10	31	1.07	1.70	0.014	2.30	1.96	2.19
	10	32	1.21	1.49	0.36	2.55	4.34	3.68
	4	34	1.09	4.22	0.016	1.52	7.92	12.8

1. 1 - Continuous Mine Operator, 3 - Roof Bolter, 4 - Shuttle Car Operator (Standard), and Shuttle Car Operator (center and off-side).
2. GM - Geometric Mean
3. GSD - Geometric Standard Deviation.
4. S - Standard

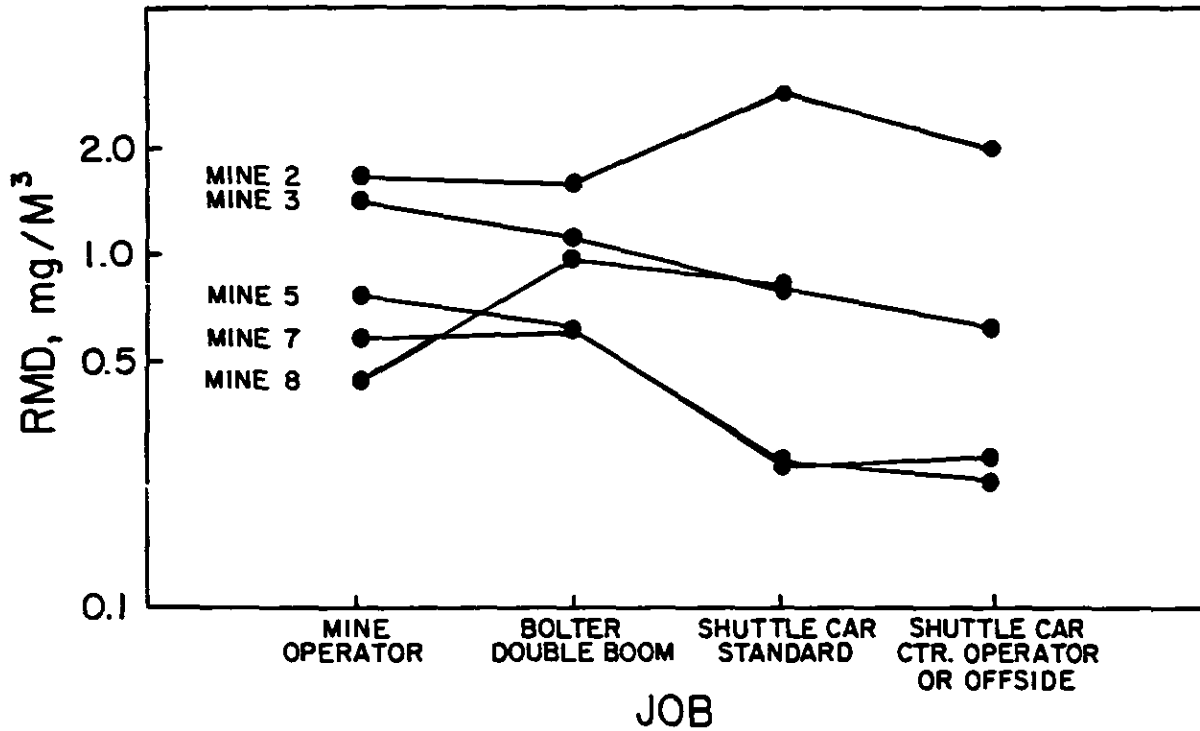

RMD Associated with Selected Jobs in Coal Mines, Expressed as Geometric Means (mg/M³).

Figure 6. Comparison of measured geometric mean exposures by occupation for RMD.

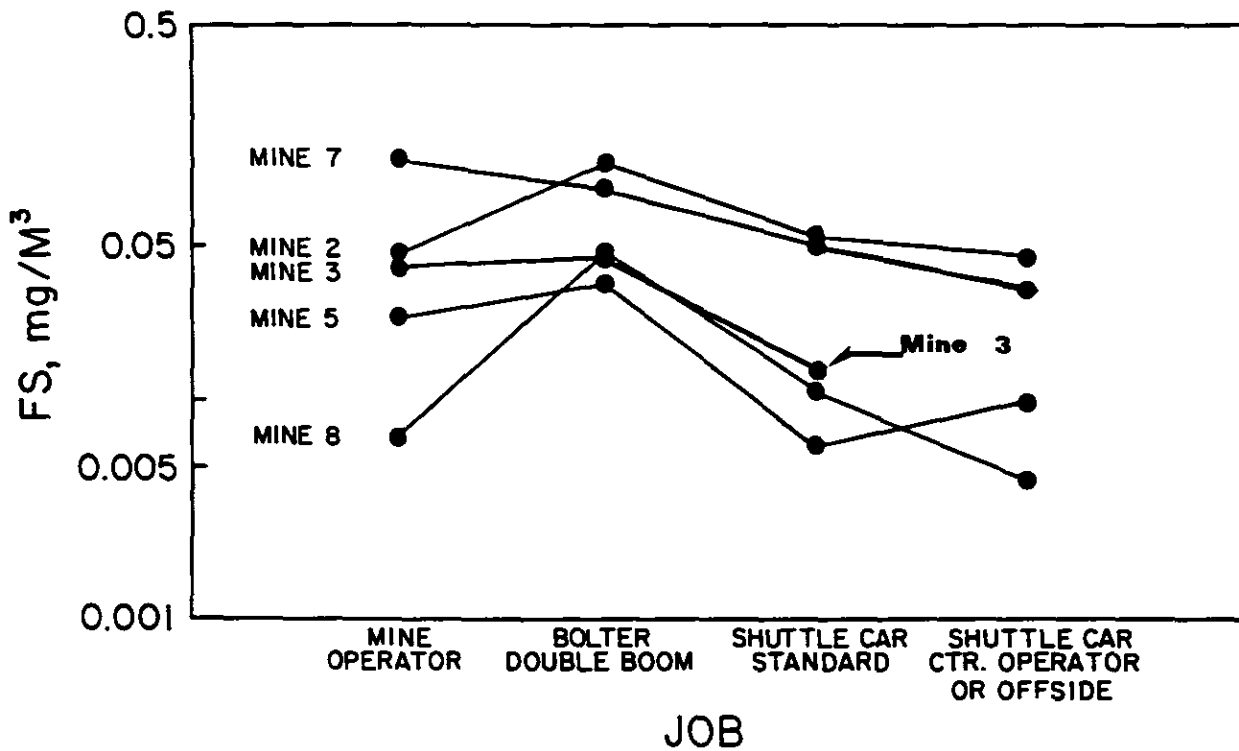

Free Silica Associated with Selected Jobs in Coal Mines, Expressed as Geometric Means (mg/M³).

Figure 7. Comparison of measured geometric mean exposures by occupation for FS.

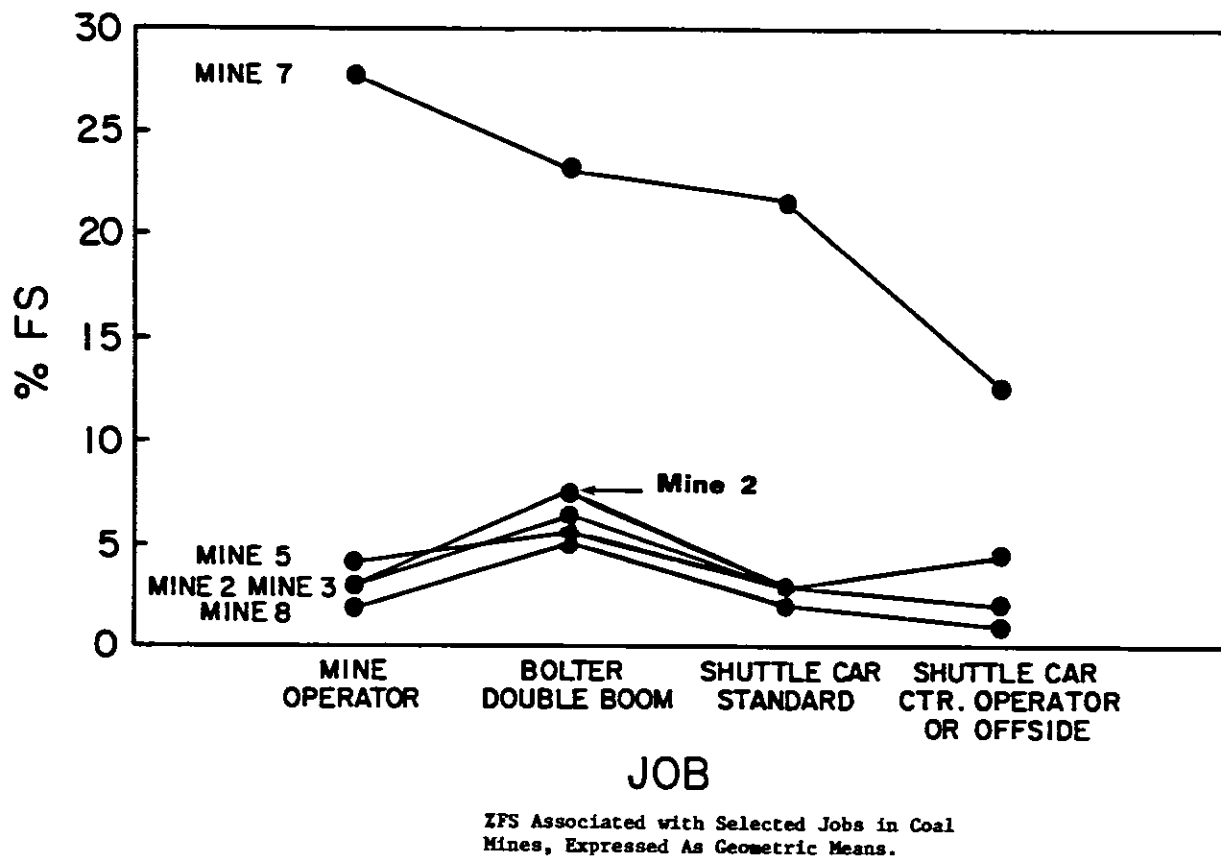

Figure 8. Comparison of measured geometric mean exposures by occupation for % FS.

or off side for coal mines (Mines 2, 3, 5, 7 and 8). Figures 6-8 demonstrate that dust exposure variability across mines is greater than the variability associated with occupations within a mine. RMD, FS and % FS levels are more dependent on the production and/or control of dust within the mine than on occupation.

% FS is more consistent than RMD or FS across all mines except mine 7 where the occupation-specific % FS averages range from 15 to 20% FS over the four occupations. This is three to four times as high as in the other mines. The occupational exposure to free silica does have a consistent pattern regardless of RMD concentrations in a mine. Bolters are exposed on average to RMD containing 2 to 3% more free silica than continuous miner and standard shuttle car operators, and about 5% more than center or offside shuttle car operators who are exposed to the lowest % FS.

TEMPORAL COMPONENT OF VARIATION

The results of the previous sections have been used in combination with the published precision of our laboratory procedures to characterize the contributions to variability in dust parameters of: laboratory analysis; sampling; time; occupation and mines. The analytical lab component is the variance among repeated lab analyses for the same sample. The sum of the laboratory and sampling variances for this investigation was estimated from the paired samples study. The sum

of all components as well as the contributions of occupation and mine have been estimated by ANOVA. By combining the results for the ANOVA and the paired sample analysis the variability over time for a given occupation and mine can be estimated.

Table III summarizes the contributions to variability from each source for RMD, FS and % FS for coal mines in absolute units and as a percent of total.

For RMD the total variance across the 157 samples was 0.76. The analysis contributes 1%; sampling contributes 20%; variability over time for the same occupation and mine contributes 33%; while variability across mines/occupations added the largest fraction, 46%. The relative contributions for free silica are similar to those for RMD. For % FS, analysis again contributed little to variability although the specific amount could not be determined from the literature. The sampling and analysis together contributed 35% to the total variation; temporal variability was approximately 30% of the total; while variation from mines/occupations was 36%.

GENERAL CONCLUSIONS

- Occupation and mine, sampler position, laboratory analysis and repeated sampling time contributions to sample variance were estimated based on the paired sample results and published values for variance associated with

Table III
Decomposition of Variance for RMD, FS and % FS by Components: (1) Occupation and Mine;
(2) Time; (3) Sampling; and (4) Laboratory for Coal Mine Data

Source	RMD Variance	FS % of Total	Variance	%FS % of Total	Variance	% of Total
Occupation and Mine	.35	46	.76	49	2.8	36
Time	.25	33	.42	27	2.3	29
Sampling	.15	20	.38	24	1.7	35
Laboratory	.01	1	.01	0	.1	1
Total	.76	100	1.57	100	7.8	100

laboratory analysis and air sampling techniques. The largest contributions to variance arose from sampling across mines and occupations, which accounted for 46% of the variability associated with respirable mine dust samples.

- The second important contributor to variance was the temporal variability of dust levels in mines, accounting for approximately 33% of total variability.

In summary, this investigation demonstrates that the largest contribution to variability results from sampling across mines.

REFERENCES

1. Breslin, J.A., Page, S.J., Jankowski, R.A.: *Precision of Personal Sampling of Respirable Dust in Coal Mines*. Bureau of Mines RI 8740, (1983).
2. Burkhart, J. Presented at the Annual *Amer. Ind. Hyg. Conference* in Dallas, TX. (1986).
3. Corn, M., Breyse, P.N., Hall, T., Chen, G., Risby, T., Swift, D.L.: A Critique of MSHA Procedures for Determination of Permissible Coal Mine Dust Containing Free Silica. *Am. Ind. Hyg. Assoc. J.* 46(1):4-8 (1985).
4. *Federal Register*, 30 CFR, Part 57.
5. *Federal Register*, 30 CFR, Parts 70 and 71.
6. General Accounting Office: *Improvements Still Needed in Coal Mine Dust Sampling Program and Penalty Assessment and Collection*. Report RED-76-56. December 31, (1975).
7. Kissel, F.N., Ruggier, S.K., Jankowski, R.A.: How to Improve the Accuracy of Coal Mine Dust Sampling. *Am. Ind. Hyg. Assoc. J.* 47(10):602-606 (1986).
8. National Bureau of Standards. "An Evaluation of the Accuracy of the Coal Mine Dust Sampling Program Administered by the Department of Interior," Final Report to the Senate Committee on Labor and Public Welfare. Washington D.C., December, (1975).
9. National Institute for Occupational Safety and Health. CDC. *Statistical Analysis of (Mining Enforcement Safety Administration) Respirable Dust Data*. (1976).
10. National Resource Council. *Measurement and Control of Respirable Dust in Mines*, (1980).
11. Page, S., Jankowski, R.: Correlations Between Measurements with RAM-1 and Gravimetric Samplers on Longwall Shearer Faces. *Am. Ind. Hyg. Assoc. J.* 45(9):610-616 (1984).
12. Watts, W. F., Parker, D. R.: Respirable Dust Levels in Coal, Metal, and Nonmetal Mines. *Bureau of Mines Information Circular #9125*, U.S. Department of Interior, Washington D.C. (1987).

NEWER CONCEPTS IN SILICA AND SILICATE LUNG DISEASE

A.R. Gibbs, M.B., Ch.B., MRC Path.

Department of Pathology, Llandough Hospital, Penarth, South Glamorgan, U.K.

Pulmonary disease may be caused by exposure to free silica and a wide variety of nonfibrous silicates. The pulmonary disease caused by chronic exposure to free silica is usually referred to as silicosis or classical silicosis. The lesion typical of silicosis is said to be the silicotic or classical silicotic nodule. Classical silicotic nodules are rounded, whorled, well demarcated very fibrotic lesions clearly demarcated from the background lung. Microscopically they have a narrow rim of dust containing macrophages admixed with randomly oriented collagen fibres, an intermediate zone of concentrically arranged collagen and a central collagenous core which may be variably hyalinised and calcified. On the other hand the mixed dust fibrotic nodule is stellate and microscopically is composed of a central zone of collagen with a periphery of linearly and radially arranged collagen admixed with dust laden macrophages.¹ The latter is said to be characteristic of pulmonary disease caused by exposure to free silica in combination with less fibrogenic dusts such as kaolin, iron oxide or carbon.¹⁻³

The occurrence of pneumoconiosis consequent to pure non-fibrous silicate exposure is debatable since commercial silicates are often contaminated by other minerals of known fibrogenicity. Relatively few cases have been described and in many of these no accurate analytical data is available.

When examining histopathological specimens of lungs from cases of so-called classical silicosis I have often been struck by the frequency of lesions other than the classical silicotic nodules. For example in a study of the lungs from North Wales slate workers, who were exposed to dust containing between 30 and 35% free silica, "mixed dust" fibrotic nodules and interstitial fibrosis were noted in a considerable proportion of the cases as well as the classical silicotic nodules.⁴ It is probably not surprising in view of the fact that slate contains considerable quantities of mica and other minerals such as chlorite, iron salts and titanium in addition to free silica. On further reflection it will be obvious that there are few if any situations where pure exposure to free silica occurs and it is nearly always accompanied by exposure to combined silicates. There is experimental evidence that the toxic effects of free silica on the lung can be modified by the presence of other minerals such as mica, haematite and coal probably by modifying the surface activity of the free silica particles but the results are difficult to predict.^{5,6} At present the precise conditions of dose, duration of exposure, mineral composition and physicochemical properties for the development of classical silicotic, mixed dust fibrotic nodules and interstitial fibrosis in humans are not fully understood. Other factors also appear to be important such as subject variation and com-

plicating disease.⁷

In this presentation I would like to outline the results that my colleagues and I have obtained from a study of autopsy lungs from a group of Cornish china clay workers since it sheds some light upon how these lesions develop.⁸ It is also one of the few studies of a pure nonfibrous silicate pneumoconiosis in which good pathological and analytical data are available.

The Cornish china clay industry is largely confined to a small geographical area located around St. Austell in the South West of England. The industry started in the 18th century when china clay and china stone deposits were worked and the products used in British pottery production. Since then the industry has expanded by increasing the production of china clay but china stone usage has ceased.

The lungs from 62 subjects who had worked in the Cornish china clay industry had been referred to the MRC Pneumoconiosis Unit between 1968 to 1981. These were studied both pathologically and mineralogically and occupational histories and chest radiographs, available in 39 cases, were obtained. As the study proceeded it became apparent that there was good agreement between the occupational histories and the mineral content of the lungs. Indeed mineralogical analysis often proved more accurate than the initial occupational history.

On the basis of the mineralogical findings three groups could be distinguished:

1. "China clay" group—kaolinite > 90%, quartz < 1.1% and feldspars < 1% by mass.
2. "China clay and china stone" group—kaolinite < 90%, quartz > 0.9%, feldspars > 1.0% by mass.
3. "Miscellaneous" group—did not meet conditions for groups 1 and 2; it was considered probable that there was exposure to other minerals.

Each lung was graded histopathologically for nodular and interstitial fibrosis and the size of any PMF lesion noted. When the histopathological gradings were compared with the mineralogical values the following conclusions were reached:

- a. Nodular fibrosis correlated better with quartz concentrations than kaolinite
- b. Interstitial fibrosis correlated better with kaolinite concentration than nodular fibrosis
- c. In the majority of cases it was relatively easy to separate the china clay cases from the china clay and china stone cases histologically.

This study shows that a pneumoconiosis may result from non-fibrous silicates in the absence of free silica, in this case kaolin, and interstitial fibrosis is the predominant lesion. Further studies of this type are necessary to comprehend the toxic effects of free silica and nonfibrous silicates on the human lung.

REFERENCES

1. Craighead, J.E., Kleinerman, M.D., Abraham, J.L., Gibbs, A.R., Green, F.H.Y., Harley, R.A., Ruettner, J.R., Vallyathan, V., Juliano, E.B.: Diseases associated with exposure to silica and non-fibrous silicate minerals. *Arch. Pathol. Lab. Med.* In Press.
2. McLaughlin, A.I.G.: Pneumoconiosis in foundry workers. *Br. J. Dis. Chest* 4:297-308 (1957).
3. Nagleschmidt, G.: The relation between lung dust and lung pathology in pneumoconiosis. *Br. J. Ind. Med.* 17:247-259 (1960).
4. Gibbs, A.R., Craighead, J.E., Pooley, F.D., Wagner, J.C.: The pathology of slate workers' pneumoconiosis in North Wales and Vermont. In: *Inhaled Particles VI*. In Press.
5. Heppleston, A.G., Morris, T.G.: The progression of experimental silicosis. *Am. J. Pathol.* 46:945-958 (1965).
6. Le Bouffant, L., Daniel, H., Martin, J.C., Bruyere, S.: Effect of impurities and associated minerals on quartz toxicity. *Ann. Occup. Hyg.* 26:625-634 (1982).
7. Koskinen, H.A., Tiilikainen, A., Nordman, H.: Increased prevalence of HLA-Aw19 and of the phenogroup Aw19,B18 in advanced silicosis. *Chest* 83:848-852 (1983).
8. Wagner, J.C., Pooley, F.D., Gibbs, A.R., Lyons, J., Sheers, G., Moncrieff, C.B.: Inhalation of china stone and china clay dusts: the relationship between the mineralogy of the dust retained in the lung and pathological changes. *Thorax* 41:190-196 (1986).

SILICA—IS IT A CARCINOGEN IN THE RESPIRATORY TRACT?

JOHN E. CRAIGHEAD, M.D.

Department of Pathology, University of Vermont, College of Medicine, Burlington, VT, USA

The role of silica in the causation of bronchogenic carcinoma in man is a contemporary question of great public health importance.^{1,2} Should silica be found to contribute to the pathogenesis of bronchogenic carcinoma, without question, rigorous controls for its use in industry must be introduced. However, my evaluation of the contemporary epidemiological, experimental and medical information at present does not permit me to conclude that the scientific evidence implicates silica in the causation of this neoplastic disease. Not only is the epidemiological information inadequate for reasons which will be discussed below, but the experimental work in animal models is deficient. In the absence of more convincing evidence, it can be stated with conviction that restrictions on the use of crystalline silica in industry should not be introduced for the sole purpose of eliminating its alleged role in cancer. There are countless studies in the medical literature which attest to the contribution of silica in the pathogenesis of pulmonary parenchymal fibrosis, but even in this area, differences of opinion exist based on the interpretation of the scientific information.³

In a widely quoted publication, Sir Bradford Hill, a noted English epidemiologist, proposed nine general criteria which should be employed in assessing the possible role of an environmental pollutant in the causation of a disease process.⁴ The evaluation of the scientific information recommended by Dr. Hill is an appropriate basis for this analysis. In brief, Hill expressed the view that a cause and effect relationship is improbable if epidemiological associations cannot be demonstrated consistently in different studies conducted by different investigators in various population groups. He also emphasized the importance of the strength of the association, for weak, but statistically significant associations can often be due to confounding factors unrelated to the issue under investigation. The plausibility and specificity of the association (i.e. the reproducible characteristics of the disease process) and the intensity of the exposure, (i.e., dosage effects) are also matters for consideration. And, finally, Hill pointed out the key role that experimental studies might have in establishing causative relationships.

Human Epidemiology: (i.e. consistency and strength of the association)

Ideally, prospective longitudinal studies of worker populations exposed to silica would provide definitive information on cancer risks, but this often is obviously not possible. Accordingly, it is necessary for epidemiologists to conduct cross-sectional analyses to determine the prevalence of a disease in a population associated with an alleged environmental pollu-

tant. By comparing the prevalence of lung cancer in a dust-exposed population with members of a comparable subset of a non-exposed population group, (presumably individuals having similar demographic characteristics) the potential risk of a disease can be established. Although a large number of systematic investigations of this type have been carried out on workers employed in a number of different industries, the results fail to conclusively implicate silica. With regard to bronchogenic carcinoma, it is imperative that considerations of tobacco smoking be employed in any analysis, since it is clearly the major risk factor in the development of the disease. In addition, among industrial workers, environmental pollutants possessing known carcinogenic properties, should also be considered and appropriately evaluated.

It is clear from a review of the published literature that the prevalence of bronchogenic carcinoma in a number of silica-exposed worker groups exceeds the prevalence in the control population.¹⁻³ However, in these studies, with one exception, cigarette smoking and exposure to toxic, potentially carcinogenic inhalants in the workers' environment have not been taken into consideration. Thus, these studies *de facto* cannot be used in a definitive analysis of the question. Admittedly, this is a difficult problem to address because of the widespread use of tobacco products among so-called "blue-collar workers." In a concerted effort to address these problems, Hessel, P.A., et al.⁵ studied South African gold miners with autopsy-proven pulmonary silicosis. In this investigation, a statistically significant increase in the prevalence of bronchogenic carcinoma was *not* found when environmental pollutants such as smoking were excluded as an alternate pathogenic consideration. This investigation was clearly superior in design to many others in view of the fact that the worker population had pathologically demonstrable silicosis. The observations referred to above contrast with the results of a study in Ontario in which applicants for workers' compensation were evaluated.⁶ In this investigation, the silica-exposed population exhibited a significant increase in bronchogenic carcinoma when the effects of cigarette smoking were controlled. However, human factors, including the potential benefits of compensation, may well have influenced and possibly biased the makeup of the cohort group. A recent epidemiological study of ceramic workers came to a similar conclusion.⁷

Exposure Criteria: (i.e. biological gradient and temporality)

Should silica dust play a role in bronchogenic carcinoma, one might expect that individuals with severe degrees of silicotic

pulmonary disease would exhibit a higher prevalence of bronchogenic carcinoma than those claiming exposure but exhibiting no evidence of silica-induced disease. There have been only two reported studies which suggest such a relationship;^{8,9} thus, a dosage effect has not been demonstrated convincingly. This is an important shortcoming of the existing epidemiological evidence.

Exclusion of Artfactual Influences: (i.e. specificity and plausibility)

Consideration of cigarette smoking has been referred to above, but pyrolysis products in several different industries and radon pollution among miners have generally not been considered in epidemiological investigations. For example, both soot and coke oven products are recognized and accepted respiratory carcinogens and radon (in hard rock miners) has been increasingly incriminated in the causation of bronchogenic carcinoma.^{10,11} Both of these general classes of carcinogens are potential confounding factors among worker populations exposed to silica dust. The role of such foreign substances as asbestos has also not been accorded reasonable consideration.¹²

Animal Studies: (i.e. experimental observations)

Three types of animal investigations have been carried out which are said to demonstrate a carcinogenic role of silica. Wagner, M.M.F. and his colleagues^{13,14} first reported that certain forms of silica possess the capacity to induce histiocytic lymphomas when inoculated into the pleural and peritoneal cavities of rats of certain specific strains. These lesions are clearly neoplastic and the phenomena is reproducible, but unexplained. Whatever the mechanism, this form of experimentation in no way can be implicated as a major consideration in assessing whether or not silica plays a role in bronchogenic carcinoma in man.

In the second type of study, animals were exposed to silica in large amounts, either by intratracheal instillation or in aerosols. In the experiments of Stenbeck, et al.,¹⁵ the silica dust was instilled with benzo-a-pyrene, a recognized respiratory carcinogen. Bronchogenic neoplasms developed. As might be expected, bronchogenic carcinomas also were found in animals exposed to foundry dust containing silica and chemical carcinogens.¹⁶ This type of investigation is similar to the pathfinding experimental work of Saffiotti and his associates carried out years ago.¹⁷ This work demonstrated the effect of mineral dusts on the uptake of carcinogens and the subsequent development of respiratory tract neoplasms in animals.

In the third type of study, rats were exposed to large amounts of dust either by intratracheal instillation or aerosol and the animals maintained until death.¹⁸⁻²² It is clear from these investigations that proliferative lesions develop in the lung parenchyma among animals with fibrotic changes attributable to the silica dust. The malignant nature of these cellular lesions, however, is questionable, for in only a single instance²⁰ was an extrapulmonary metastatic lesion demonstrated. It is important to evaluate these studies critically, since adenomas and adenomatosis, as well as squamous

metaplasia, occur commonly in the lungs of dust-exposed experimental animals as a non-specific cellular response to foreign particulates. Although these lesions mimic malignancy at times, they do not exhibit most of the biologic properties of malignancy. Although the investigators claim that adenocarcinomas and squamous carcinomas developed in exposed animals, their conclusions can be faulted for the following reasons. Firstly, detailed descriptions documenting the morphologic features of malignancy were not provided in the publications and a critical unbiased review of the tumors by a pathologist, expert in the diagnosis of lung cancer was not conducted. Secondly, no apparent attempt was made to demonstrate the biologic malignancy of these lesions by transplantation into alternate hosts such as syngenic animals or nude, athymic mice. And, thirdly, metastases, the critical measure of malignancy, were demonstrated in only a single animal. Investigators working in the area of respiratory carcinogenesis are well acquainted with the adenomatosis and squamous metaplasia which sometimes mimics carcinomas in animals. In the absence of evidence, more concretely establishing the biologic nature of the lesions described, it is difficult to conclude *de facto* that malignancies developed in experimental animals consequent to silica dust exposure.

Pathogenetic Construct: (i.e. plausibility, coherence and analogy)

Experimental studies have not provided a basis for hypothesizing a mechanism of carcinogenesis in man or animals. Silica has not been shown convincingly to be a genotoxic substance and there is no convincing evidence that it serves as a foreign body carcinogen or induces cancer as a result of chronic irritation. Thus, one has little basis for hypothesizing how silica might act, were one to accept the evidence implicating silica in neoplastic disease in experimental animals or man.²³

CONCLUDING REMARKS

In summary, the experimental evidence in animals, suggesting a possible role of silica in the pathogenesis of bronchogenic carcinomas, is incomplete. I also conclude that the epidemiological studies in humans provide insufficient evidence to permit one to conclude that man is at increased risk of developing carcinoma of the lung as a result of silica dust exposure. My comments in no way exclude silica from consideration as a cause of bronchogenic carcinoma, but only point out the inadequacies of the contemporary scientific information and emphasize the need for additional, carefully designed systematic studies. In the light of the existing information, regulations designed to eliminate the alleged potential of silica in the causation of cancer of the lung are premature.

REFERENCES

1. Silica-exposed workers. In: *The Health Consequences of Smoking. Cancer and Chronic Lung Disease in the Workplace.* A report of the Surgeon General. 1985, pp. 321-54.
2. Goldsmith, D.F., Guidotti, T.L., Jonston, D.R.: Does occupational exposure to silica cause lung cancer? *Amer. J. Indust. Med.* 1982, 2:423-440.
3. Craighead, J.E., Kleinerman, J., Abraham, J.L., et al: Diseases associated with exposure to silica and nonfibrous silicate materials. *Arch. Pathol. Lab. Med.* 1988, 112:673-720.

4. Hill, B.: The environment and disease: association or causation? *Proc. Royal. Soc. Med.* 1965, 29S-30.
5. Hessel, P.A., Sluis-Cremer, G.K., Hnizdo, E.: Case-control study of silicosis, silica exposure, and lung cancer in white South African gold miners. *Amer. J. Indust. Med.* 1986, 10:57-62.
6. Finkelstein, M.M., Liss, G.M.: *Proceedings of the Third International Conference of Environmental Lung Disease*, October 15-18, 1986.
7. Forastiere, F., Lagorio, S., Michelozzi, P., et al: Silica, silicosis and lung cancer among ceramic workers: A case-referent study. *Am. J. Ind. Med.* 1986, 10:363-370.
8. Mur, J.M., Meyer-Bisch, C., Pham, Q.T., et al: Risk of lung cancer among iron ore miners: A proportional mortality study of 1,075 deceased miners in Lorraine, France. *J. Occup. Med.* 1987, 29:762-768.
9. Swaen, G.M.H., Passier, P.E.C.A., van Attekum, A.M.N.G.: Prevalence of silicosis in the Dutch fine-ceramic industry. *Int. Arch. Occup. Environ. Health* 1988, 60:71-74.
10. *Fourth Annual Report on Carcinogens. Summary 1985*. U.S. Department of Health and Human Services. Public Health Service.
11. NIOSH Recommendations for Occupational Safety and Health Standards 1988. *Morbidity and Mortality Weekly Report*. U.S. Department of Health and Human Services. Public Health Service.
12. Craighead, J.E., Mossman, B.T.: The pathogenesis of asbestos-associated diseases. *NEJM* 1982, 306:1446-1455.
13. Wagner, M.M.F., Wagner, J.C., Davies, R. et al.: Silica-induced malignant histiocytic lymphoma: Incidence linked with strain of rat and type of silica. *Br. J. Cancer* 1980, 41, 908.
14. Wagner, M.M.F., Wagner, J.C.: Lymphomas in the wistar rat after intrapleural inoculation of silica. *J. Natl. Cancer. Inst.* 1972, 49:81-91.
15. Stenback, F., Wasenius, V.M., Rowland, J.: Alveolar and interstitial changes in silicate-associated lung tumors in Syrian hamsters. In: *Silica, Silicosis and Cancer*, eds. Goldsmith, Winn, and Shy, 1986, pp. 199-213.
16. Niemeier, R.W., Mulligan, L.T., Rowland, J.: Cocarcinogenicity of foundry silica sand in hamsters. In: *Silica, Silicosis and Cancer*, eds. Goldsmith, Winn, and Shy, 1986, pp. 215-27.
17. Saffiotti, U., Stinson, S.F., Keenan, K.P., et al: Tumor enhancement factors and mechanisms in the hamster respiratory carcinogenesis model. In: *Carcinogenesis—A Comprehensive Survey. Cancer of the Respiratory Tract: Predisposing Factors*. eds. Mass, M.J., Kaufman, D.G., Siegfried, J.M., Steele, V.E., Nesnow, S. 1985, 8:63-92.
18. Groth, D.H., Stettler, L.E., Platek, S.F., et al.: Lung tumors in rats treated with quartz by intratracheal instillation. In: *Silica, Silicosis and Cancer*, eds. Goldsmith, Winn, and Shy, 1986, pp. 243-86.
19. Harvey, J.J., Wagner, M.M.F., Edwards, A., et al.: Tumors induced experimentally by silica: Establishment and characterization of malignant cell lines *in vitro*. In: *Silica, Silicosis and Cancer*, eds. Goldsmith, Winn, and Shy, 1986, pp. 229-42.
20. Dagle, G.E., Wehner, A.P., Glark, M.L. et al.: Chronic inhalation exposure of rats to quartz. In: *Silica, Silicosis and Cancer*, eds. Goldsmith, Winn, and Shy, 1986, pp. 266-66.
21. Holland, L.M., Wilson, J.S., Tillery, M.I. et al.: Lung cancer in rats exposed to fibrogenic dusts. In: *Silica, Silicosis and Cancer*, eds. Goldsmith, Winn, and Shy, 1986, 267-79.
22. Johnson, N.F., Smith, D.M., Sebring, R. et al.: Silica-induced alveolar cell tumors in rats. *Amer. J. Indust. Med.* 1987, 11:93-107.
23. Heppleston, A.G.: Silica. pneumoconiosis, and carcinoma of the lung. *Amer. J. Indust. Med.* 1985, 7:285-94.

POSTER SESSIONS I-IV

THE FIBROSIS AND OTHER MORPHOLOGIC CHANGES OF RAT LUNG CAUSED BY INTRATRACHEAL INJECTION OF DIFFERENT SIZES OF METALLIC ALUMINUM DUSTS

ZHOU CHEN, M.D. • Chen Hongchuang, M.D.

Department of Public Health, China Medical University, Shenyang, People's Republic of China

INTRODUCTION

The study of relationship between pulmonary biological effect and sizes of dust is the basis for toxicological evaluation of dust and setting up dust sampling curve.^{1,2} Although there were a few of this kind of studies in the past, it has not been intensively investigated. Several studies concerning the fibrogenic effect of different sizes of silica dust showed that the strongest fibrogenic size is under 5 μm , and particle size influenced the fibrotic response and other morphological characteristics of animal lung.^{3,4,5} There was no study of the fibrogenic effect of different sizes of dust other than silica, such as metal dust. Also the morphological characteristics of animal lung caused by different sizes of dusts has not been evaluated thoroughly. In this paper, we present the experimental result of our studies of biological effects of different sizes of metallic aluminum dusts.

MATERIALS AND METHODS

Aluminum Dusts

Metallic aluminum dusts were obtained from an aluminum company which manufactured aluminum powders with different sizes. The powders were repeatedly separated by the method of sedimentation in ethyl ether. The particles with 1 μm , 5 μm , 10 μm , 15 μm optic diameters were collected, then these particulates were further separated by particulate centrifuge. The optic diameters of the separated aluminum particles were determined under microscope and presented in Table I. The chemical composition of these aluminum particulates were: aluminum, 96%; alumina, 3%; ferric oxides, 0.3%. No toxic heavy metals were detected (atomic absorption spectrometry).

Animal

Wistar outbred strain male rats weighing between 200 and 250 g were used for experiment.

Intratracheal Injection

50 mg of aluminum dust was suspended in 1.0 ml of saline. 5 groups of rats were used. Each group of rats were intratracheally injected respectively with 1.0 ml of 1 μm , 5 μm , 10 μm , 15 μm aluminum dust suspension or saline. The rats were sacrificed 6, 9 months after injection. A total of 100 rats were evaluated in this study and about 10 rats were evaluated in each group at each time point.

Lung Weight and Collagen Content

5 rats in each group were sacrificed with overdose of pentobarbital and their thoracic cavity was opened immediately. After removal of heart and tracheal, the wet lung weight was recorded. The dry weight of the lung was determined after the lung was cut into small pieces and dried in 110°C for 2 hours. The hydroxyproline was analyzed by acid hydrolysis of these dry pieces of lung tissue. The collagen content was estimated from determination of hydroxyproline.

Morphological Studies

About 5 rats in each group were sacrificed and their lungs were instilled drop by drop with 10% formalin. A longitudinal section of the lung, and the lymph node were cut and embedded in paraffin. The sections were stained with hematoxylin and eosin (HE), and also stained for reticulin and collagen.

The histopathologic changes of rat lungs were observed under

Table I
The Particle Sizes of the Experimental Aluminum Dusts

Size (μm)	Size distribution of aluminum particles (%)										
	<1	1-	2.5	2.5-	5	7.5-	10.0	12.5-	15	17.5-	20-
1	5	80	10	4	1						
5			4	10	75	10	1				
10				1	4	8	73	8	3	2	
15						1	2	5	70	18	4

microscope. The degree of nodular fibrosis was evaluated by Belt-King classification. In each lung, left lobe and right lobes were selected to measure the area of nodular fibrosis, area of alveolar wall thickening, area of emphysema. The area of nodular formation and alveolar wall thickening and emphysema were determined under 10 x 10 microscope with a 10 x 10 graticule (3.24 mm² in area). 12 locations in each lobe were randomly selected for quantitative observation and 12 lobes were evaluated in each group. The values presented were average of the 144 measurement.

RESULTS

Lung Weight and Collagen Content

Rats injected with aluminum dust had higher lung weight (wet and dry) and total collagen than control rats. The increase of lung weight and collagen content in 5 μm, 1 μm groups had statistical significance when compared with control group. Although the lung weight and collagen content were higher in 10 μm and 15 μm groups than control group, there was no statistical significance. (Figures 1, 2 and Table II)

Among animals exposed to different sizes of dust, the rats injected with 5 μm, 1 μm dusts have significantly higher lung weight and collagen content than those of rats in 10 μm, 15 μm groups. The order of increase of above parameter was: 5 μm > 1 μm > 10 μm > 15 μm. After statistical analysis of difference between each two groups, we found lung wet

weight had significant difference between every two groups except the comparison between 10 μm and 15 μm groups. Dry weight and collagen had significant difference between every two groups except no statistical difference between 10 μm and 15 μm groups, 1 μm and 5 μm groups. (Figures 1, 2 and Table II)

Quantitative Lung Morphology

Six and nine months after intratracheal injection with different sizes of aluminum dusts, the major histological changes of rat lung were nodular fibrosis, interstitial fibrosis (or alveolar wall thickening) and emphysema. The degree of nodular fibrosis of rat lung was evaluated by Belt-King's grading. This result was shown in Table III. At end of experiment (9 months after injection), average degree of nodular fibrosis was 3.5 in 5 μm group, 2.6 in 1 μm group, 1.4 in 10 μm and 1.2 in 15 μm groups.

The extent of nodular fibrosis, alveolar wall thickening and extent of emphysema were determined by counting the number of graticules with positive changes in a total of 100 graticule under microscope. Table IV shows these quantitative results. The area (number of graticule with positive histological changes) of nodular fibrosis of rat lung was largest in 5 μm group, smallest in 15 μm group. The 10 μm group had significant larger area of alveolar wall thickening than those of other groups. The areas of emphysema were larger in 10 μm and 15 μm groups than 1 μm and 5 μm groups.

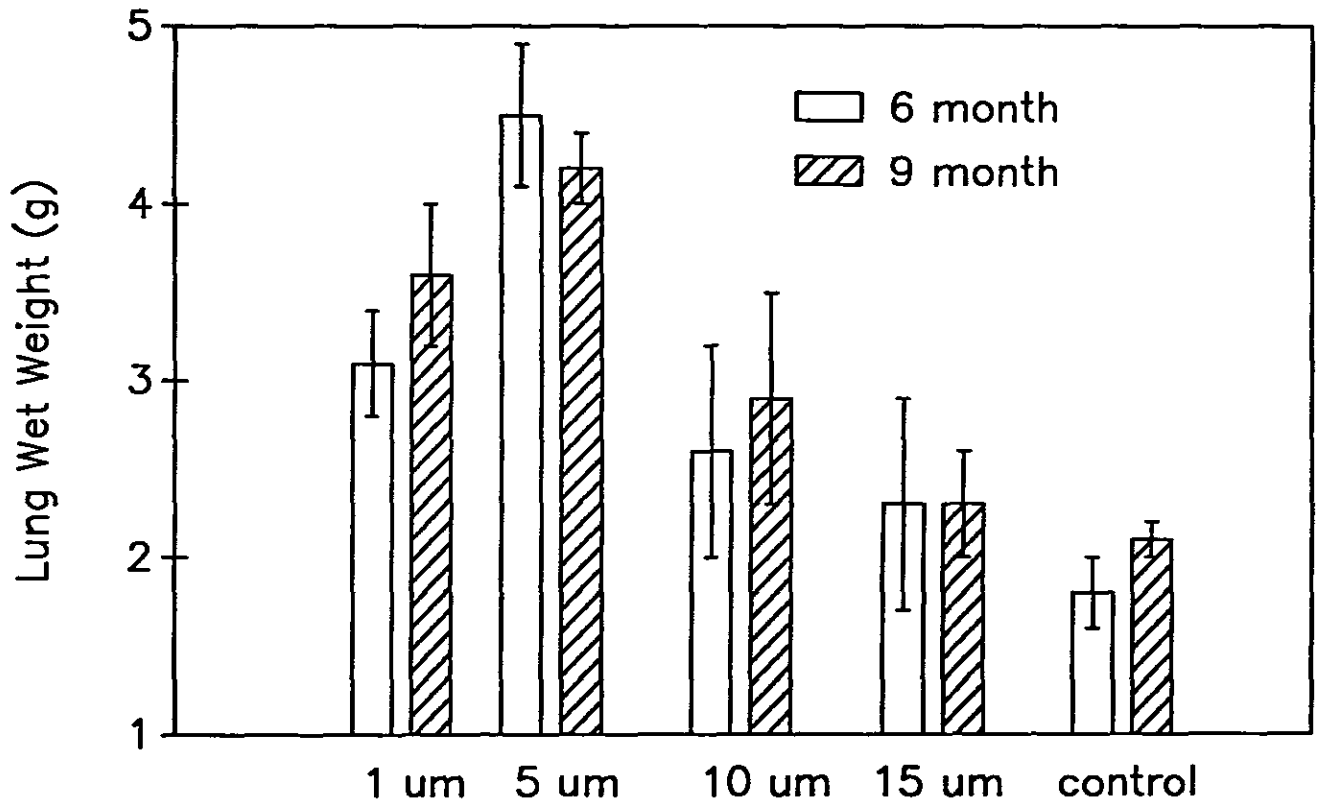

Figure 1. The changes of lung wet weights among rats intratracheally injected with different sizes of aluminum dusts.

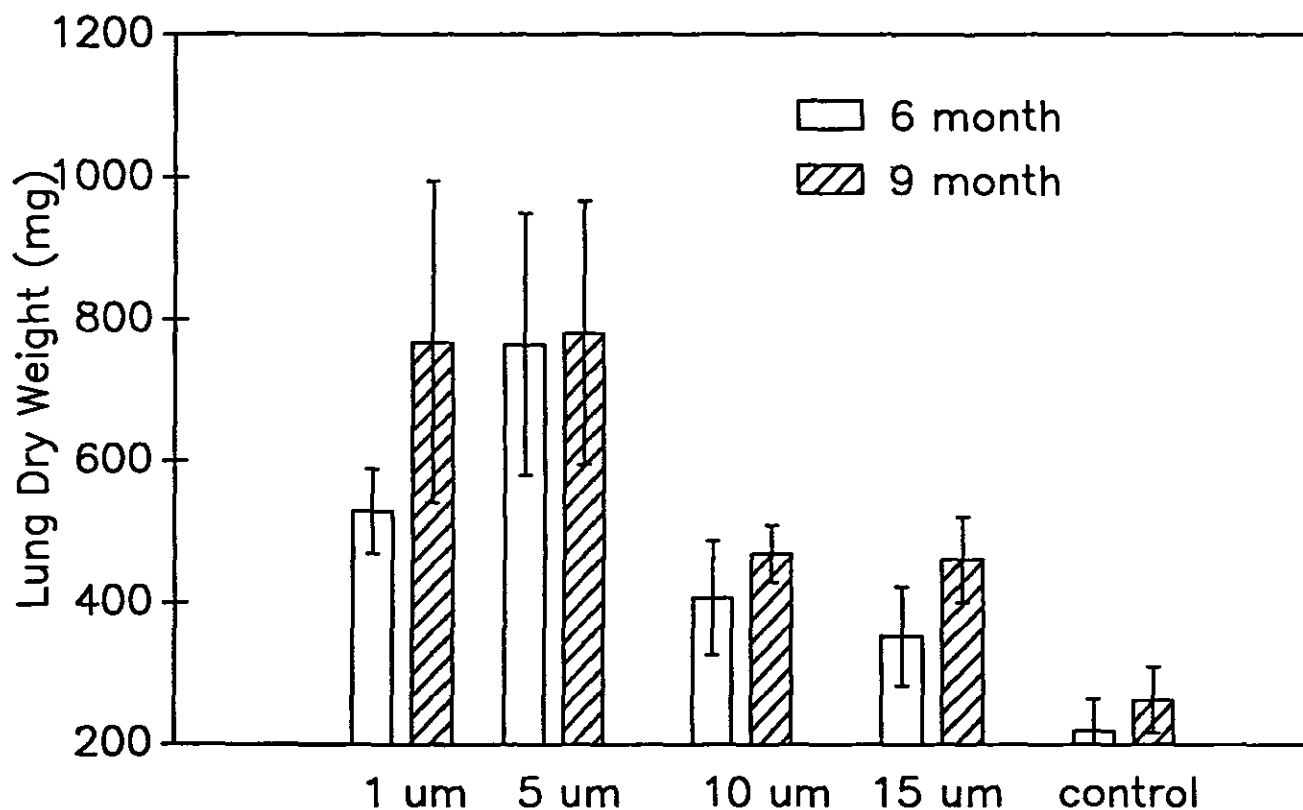

Figure 2. The lung dry weight among rats intratracheally injected with different sizes of aluminum dusts.

Table II

The Lung Collagen of the Rats Administered with Different Sizes of Aluminum Dusts

Group	Time (month)	No. of rats	Collagen (mg)	
			mean	SD
1 μm	6	5	55.0	14.6**
	9	5	65.4	28.4*
5 μm	6	5	74.0	16.2**
	9	4	76.4	16.8**
10 μm	6	5	25.2	7.0
	9	5	34.6	13.2
15 μm	6	5	23.8	4.8
	9	5	23.2	12.1
control	6	5	15.8	3.6
	9	5	22.4	2.6

*: comparing with control group, $P < 0.05$.

** : comparing with control group, $P < 0.01$.

Table III
The Lung Fibrosis of Rats Administered with Different Sizes of Aluminum Dusts

Group	Time (month)	No. of rats	Degree of fibrosis [‡]					Average
			I	II	III	IV	V	
1 μm	6	5	1	2	2	0	0	2.2
	9	5	0	2	3	0	0	2.6
5 μm	6	5	0	2	3	0	0	2.6
	9	4	0	0	2	2	0	3.5
10 μm	6	6	5	1	0	0	0	1.2
	9	5	3	2	0	0	0	1.4
15 μm	6	5	5	0	0	0	0	1.0
	9	5	4	1	0	0	0	1.2

‡: Belt-King's grading.

Table IV
The Quantitative Measurement of Areas* of Nodular Fibrosis, Alveolar Wall Thickening, Emphysema

Groups	Time (month)	No. of lung	Area of nodular fibrosis		Area of alveolar wall thickening		Area of emphysema	
			mean	SD	mean	SD	mean	SD
1 μm	6	12	1.0	0.04	22.7	3.5	4.2	1.7
	9	12	2.8	0.10	15.7	3.3	8.4	1.5
5 μm	6	12	7.2	0.41	24.2	4.1	1.4	0.4
	9	12	6.6	0.22	18.0	4.3	7.2	1.8
10 μm	6	12	2.5	0.21	36.2	3.9	10.1	3.9
	9	12	1.6	0.11	27.3	5.2	17.2	2.9
15 μm	6	12	0.2	0.01	26.5	4.5	8.0	1.9
	9	12	0.3	0.04	17.8	5.6	16.4	3.3
control	6	12	--	--	--	--	2.3	0.7
	9	12	--	--	--	--	2.5	1.2

*: Number of graticule with positive pathologic changes in a total of 10 * 10 graticule (3.24 mm²) under microscope.

Other Major Morphological Changes

9 months after intratracheal injection, rat lung and lymph nodes in different size groups had their own features. In rats injected with 1 μm dust, there were slight thickening of alveolar wall with reticulin and slight collagen staining, inflammatory cells infiltration with reticulin and collagen proliferation around bronchiole, dust foci with reticulin staining within lymph nodes. In rats administered with 5 μm aluminum dust, there was significant alveolar wall fibrosis with intensive collagen staining, a large amount of inflammatory cell infiltration and collagen fiber proliferation around bronchiole and many dust-cell foci with collagen staining in lymph nodes. While in the 10 μm group, significant alveolar wall cell proliferation with only mild reticulin increase was observed, there

was only slight increase of reticulin around bronchiole and a few dust foci in lymph nodes. The rat lung treated with 15 μm aluminum particles showed only slight alveolar wall thickening or dust deposition and no pathological changes around bronchiole and within lymph nodes. Lung and lymph nodes of control rats were normal.

DISCUSSION

According to the few past experimental studies on silica, the strongest fibrogenic size was below 5 μm . King et al studied 4 kinds of different sizes of silica. He found that the fibrogenicity was strongest in 1-2 μm silica, 0.5-1.0 μm and 2.0-4.0 μm silica were less fibrogenic, 4.0-8.0 μm silica only

produced slight fibrosis.³ Kysela et al investigated 9 kinds of different silica dusts ranging from 0.7 to 35 μm . He reported that 1 μm silica caused strongest fibrosis response in animal lung, 7–10 μm silica caused cell nodule, 35 μm silica only produced alveolar wall thickening.⁴ Goldstein and Webster reported that 2–5 μm silica had stronger fibrosis response than 1–2 μm silica.⁵ All these results show that there is a strong fibrogenic size of dust.

In our study, we selected metallic aluminum dust to study the relationship between particle sizes and lung biological response. The metallic aluminum dust was selected because it is a known strong fibrogenic dust.^{6,7,8,9} Metallic aluminum dust could cause nodular lung fibrosis, interstitial lung fibrosis and emphysema, which include nearly all chronic pathological changes from inhalation of toxic dust.

After 6, 9 months of intratracheal injection of 50 mg dust, we found 5 μm , 1 μm dusts were more fibrogenic than 10 μm , 15 μm dust. 5 μm and 1 μm aluminum dusts caused grade III even grade IV lung nodular fibrosis, intensive staining of collagen fiber in alveolar wall and higher collagen content than control animals; while 10 μm and 15 μm aluminum dusts produced only grade II or less than grade II lung nodule, increase of reticulin in alveolar wall and no significant increase of lung collagen protein. These results demonstrated that the strong fibrogenic size of metallic aluminum dust was smaller than 5 μm . 10 μm particles were less fibrogenic and 15 μm particles were non fibrogenic. Our results were consistent with those findings in silica.

Between 1 μm and 5 μm aluminum dust, we found 5 μm dust was more fibrogenic. This is similar to Goldstein and Webster's results. The strongest fibrogenic particle of aluminum dust is between 1 μm and 5 μm .

We also found that 10 μm aluminum dust produced significant alveolar wall thickening (cell proliferation) and slight emphysema. Snipes et al reported that 10–13 μm particle was removed from animal lung slower than 7–9 μm particles and

even much slower than 3 μm particles.^{10–11} Because a considerable amount of particles between 10 μm and 15 μm were found in the lung of pneumoconiosis workers, we should not overlook the biological effect of particles between 10 μm and 15 μm .

We concluded from our study that metallic aluminum particles between 1 μm and 5 μm caused strong fibrosis response and particles larger than 15 μm were not fibrogenic. Although 10 μm particle had slight fibrogenic effect, it produced alveolar wall thickening and slight emphysema. The biological effect of 10 μm particles should not be overlooked.

REFERENCES

1. Xing, G.C.: Advance in Pneumoconiosis Research. *Occup. Med.* 12:43-45 (1985). [in chine]
2. Liu, H.J.: Advance in Dust Control Technology. *Chin. J. Ind. Hyg. Occup. Med.* 3:48-50 (1985). [in chine]
3. King, E.J., Mohanty, G.P., Harrison, C.V., Nagelschmidt, G.: The Action of Flint of Variable Size Injected at Constant Weight and Constant Surface into the Lungs of Rats. *Brit. J. Ind. Med.* 10:76-92 (1953).
4. Kysela, B., Jiracova, D.H., Skoda, V.: The Influence of the Size of Quartz Dust Particles on the Reaction of Lung Tissue. *Ann. Occup. Hyg.* 16:103-129 (1973).
5. Goldstein, B., Webster, I: Intratracheal Injection into Rats of Size-graded Silica Particles. *Brit. J. Ind. Med.* 23:71-74 (1966).
6. Corrin, B.: Aluminum Pneumoconiosis II. Effect on the Rat Lung of Intratracheal Injections of Stamped Aluminum Powders. *Brit. J. Ind. Med.* 20:268-276 (1963).
7. Mitchell, J., Manning, G.B., Molyneux, M., Lane, R.E.: Pulmonary Fibrosis in Workers Exposed to Finely Powdered Aluminum. *Brit. J. Ind. Med.* 18:10-20 (1961).
8. McLaughlin, A.I.G, Kazantzis, G., King, E., Donald, Teare, Porter, R.J., Owen, R.: Pulmonary Fibrosis and Encephalopathy Associated with the Inhalation of Aluminum Dust. *Brit. J. Ind. Med.* 19:253-263 (1962).
9. Gross, P.: Pulmonary Reaction to Metallic Aluminum Powder. *Arch. Environ. Health* 26:227-236 (1973).
10. Snipes, M.B., Chavez, G.T., Muggenburg, B.A.: Disposition of 3-, 7-, and 13- μm Microspheres Instilled into Lungs of Dogs. *Environ. Res.* 33:333-342 (1984).
11. Snipes, M.B., Clem, M.F.: Retention of Microsphere in the Rat Lung after Intratracheal Instillation. *Environ. Res.* 24:33-41 (1981).

RESPIRATORY SYMPTOMS AND LUNG FUNCTION IN JUTE PROCESSING WORKERS: A PRIMARY INVESTIGATION

ZHOU CHEN, M.D. • Zenlin Liu, M.D. • Chinshan Ho, M.D. • Jiezhi Lou, M.D.

Department of Public Health, China Medical University, Shenyang, People's Republic of China

INTRODUCTION

Effect of vegetable dusts on the workers' health has been noticed for many years, but only in recent years has much attention been paid to this occupational problem.^{1,2,3} Although there have been a few studies on the health effect of jute dust, little information was available for the chronic effect of jute dust exposure. In the early 1960s, Mair et al and Gilson et al found no "Monday" symptom and no acute lung function injury in jute-dust exposed workers in Britain.^{4,5} But a few investigators had reported lung function decrement in the first working shift and atypical chest tightness in jute processing workers in other countries.⁶⁻⁸ In this report, we conducted an industrial hygiene survey and respiratory symptoms investigation as well as lung function measurements to verify if there was any occupational lung disease problem in the China jute industry. We also attempted to explore the possible mechanisms of the lung injury in this industry.

SUBJECTS AND METHODS

Subjects

404 jute exposed workers were included in the study. The criteria for selecting workers for examination were: (1) at least one year of dust exposure; (2) without asthma, tuberculosis, heart disease; and (3) no current respiratory infection. Among these workers, 217 were male, 187 were female. The control group contained 396 workers coming from the same city and had jobs of similar labor intensity but had not been exposed to toxicant or dust. Among these workers, 236 were male and 160 were female.

Questionnaire

Because the workers rest 24 hours after working for three days, the medical examinations were carried out before the beginning of the first working day. The workers were questioned about their respiratory symptoms by a trained physician. The questionnaire was based on the MRC respiratory symptom questionnaire with emphasis placed on the chronic respiratory symptoms and chronic lung diseases as well as occupational exposure history. Measurement of body weight and height were also conducted.

Lung Functions

Spirometry was performed using a waterseal spirometer. The subject performed the maximum expiratory flow-volume curve and repeated the performance until at least three accept-

able curves were obtained. Subjects who did not have acceptable curves were excluded. Lung function analysis was performed on the curve with largest value. Forced vital capacity (FVC), forced expiratory volume in one second (FEV_{1.0}), and FEV_{1.0}/FVC were measured. Measurements were converted to BTPS. Multiple regression equations were established by use of lung function data from control workers who had no respiratory symptom. When establishing the regression equations, age, height, body weight, smoking and sex were considered as variables. The predicted values of lung function of all workers were calculated according to the established equations. The lower limits of abnormal values were 0.80 for predicted FVC, and 0.75 for predicted FEV_{1.0}/FVC. The criteria for selecting abnormal of predicted FEV_{1.0} were selected according to WHO's suggestion: >0.80, normal; 0.79-0.60, slight or moderately abnormal; <0.60, severely abnormal.

Industrial Hygiene Investigation

The jute mill studied consists of two parts: a weaving factory producing jute sacks and a spinning mill producing fine rope. The jute was brought to the mill from various regions in China and then was processed in the following steps: mixing, softening the fiber with mineral water and pressed through a "softener," carding, roving, spinning, winding, weaving, and finishing. The manufacturing procedures in the weaving factory and in the spinning mill were quite similar except no weaving and finishing existed in the spinning mill. Total dust concentration was measured by area sampling. A total of 106 samples were obtained. The dust levels indicated in this paper were the arithmetic means of the time weighted average values for the locations sampled in each workplace.

RESULTS

Dust Concentration and Its Chemical Composition

The dust concentration in different jute processing areas is shown in Table I. Dust concentrations in spinning mills were higher than those in weaving factories. The mixing, softening procedure produced very high levels of dust, and dusts in these areas contained high mineral material and high silica (13.3%-14.3%). Dust levels in other areas were lower than 5 mg/M³ and contain low mineral material and less than 5% silica. After averaging the results of dust distribution from different workplaces, we found 65.1% of particles were under 5 μ m; 23.5% of particles were between 5.0 to 10.0 μ m; only 12.4% particles were larger than 10 μ m. This result indicated

Table I
Dust Concentration and Its Chemical Composition in Jute Mills

Procedures	Total dust (mg/M ³)			
	weaving factory	spinning mill	Ash (%)	Silica (%)
mixing#*	35.6	53.6	50.9	14.3
softening#*	48.5	120.3	25.4	13.4
carding#*	4.0	6.8	12.6	6.2
spool#*	1.5	1.8	1.6	1.6
copping#	1.8	-	1.8	1.8
roving*	-	1.9	20.9	1.8
Spinning#*	4.9	8.6	8.3	1.1
copping*	-	20.4	5.8	1.4
winding*	-	0.9	12.2	1.3
weaving#	1.6	-	11.1	2.3
finishing#	2.2	-	5.8	1.5

#:manufacturing procedure in weaving factory
*:manufacturing procedure in spinning mill

that most jute dusts in this mill were inhalable.

Respiratory Symptoms

In order to find the chronic effect of jute dust exposure, we included many workers who had been employed more than 20 years or were ex-workers. This resulted in a difference in the age distribution between two groups. The exposed group had more workers who were over 50 years old. There were nearly 40% of workers who had been exposed to dust for more than 20 years. So, standardization method (chi square test for comparison of rates with inner distribution difference) was used to compare the respiratory symptoms between two groups. Figures 1 to 3 show the results of the comparison. Because few female smokers existed in both groups, comparison of the symptoms was only conducted in female nonsmokers. Prevalence of all the respiratory symptoms were higher in exposed groups than in control groups. Exposed workers had significantly higher prevalence of cough, chest tightness symptoms than control workers in both male smokers and nonsmokers groups. In exposed female nonsmokers, the prevalence of cough, bronchitis, chest tightness and dyspnea were also significantly higher when compared with those of control female nonsmokers. We also compared the prevalence of respiratory symptoms in smokers and nonsmokers. In exposed male, the prevalence of cough and bronchitis were significantly higher in smokers than those in nonsmokers ($X^2 = 6.09$, $P < 0.05$; $X^2 = 5.54$, $P < 0.05$). In control male workers, the smokers had significantly higher prevalence of cough compared with nonsmokers ($X^2 = 12.1$, $P < 0.01$).

Lung Function

The abnormal of lung function was evaluated by the percentage of predicted value. Table II shows the results of the com-

parison of abnormal rates of FVC, FEV_{1.0}, FEV_{1.0}/FVC between the exposed workers and control workers. The abnormal rates of FVC, FEV_{1.0} and FEV_{1.0}/FVC were significantly higher than those in exposed workers. Comparing with control workers, the exposed workers had increased 3.2% abnormal rate in FVC; 12.9% abnormal rate in FEV_{1.0}, 7.5% abnormal rate in FEV_{1.0}/FVC. 5.4% of exposed workers had severe abnormality of FEV_{1.0}.

Because smoking is an important factor in causing lung dysfunction, we used FEV_{1.0} to analyze the effect of smoking on lung function. FEV_{1.0} was selected since it is an important index to evaluate the permanent lung function injury due to vegetable dusts.¹ The comparison of abnormal of FEV_{1.0} between male smokers and nonsmokers in exposed and control groups were shown in Table III. Odd ratios were calculated to analyze the contribution of smoking and dust exposure to abnormality of lung function. The results indicated both dust exposure and smoking would cause lung function loss, but dust exposure was much more effective than smoking. Dust exposure and smoking had combined effects in increasing abnormal rate of FEV_{1.0}.

DISCUSSION

Recently, more attention has been paid to the chronic effect of vegetable dust.^{1,2,9} Some investigators have studied chronic effects of cotton, flax dusts.^{9,10,11,12,13} They found permanent lung injury in cotton workers.^{10,11,12} The permanent lung injury or loss of lung function may not necessarily come from "Monday" symptom and acute reversible lung function decrement.² In our study, we found jute dust exposure caused increased prevalence of caught, chest tightness in exposed male workers (both smokers and nonsmokers) and increased prevalence of caught, chest tightness, chronic bronchitis, dyspnea in female workers (nonsmokers). Among

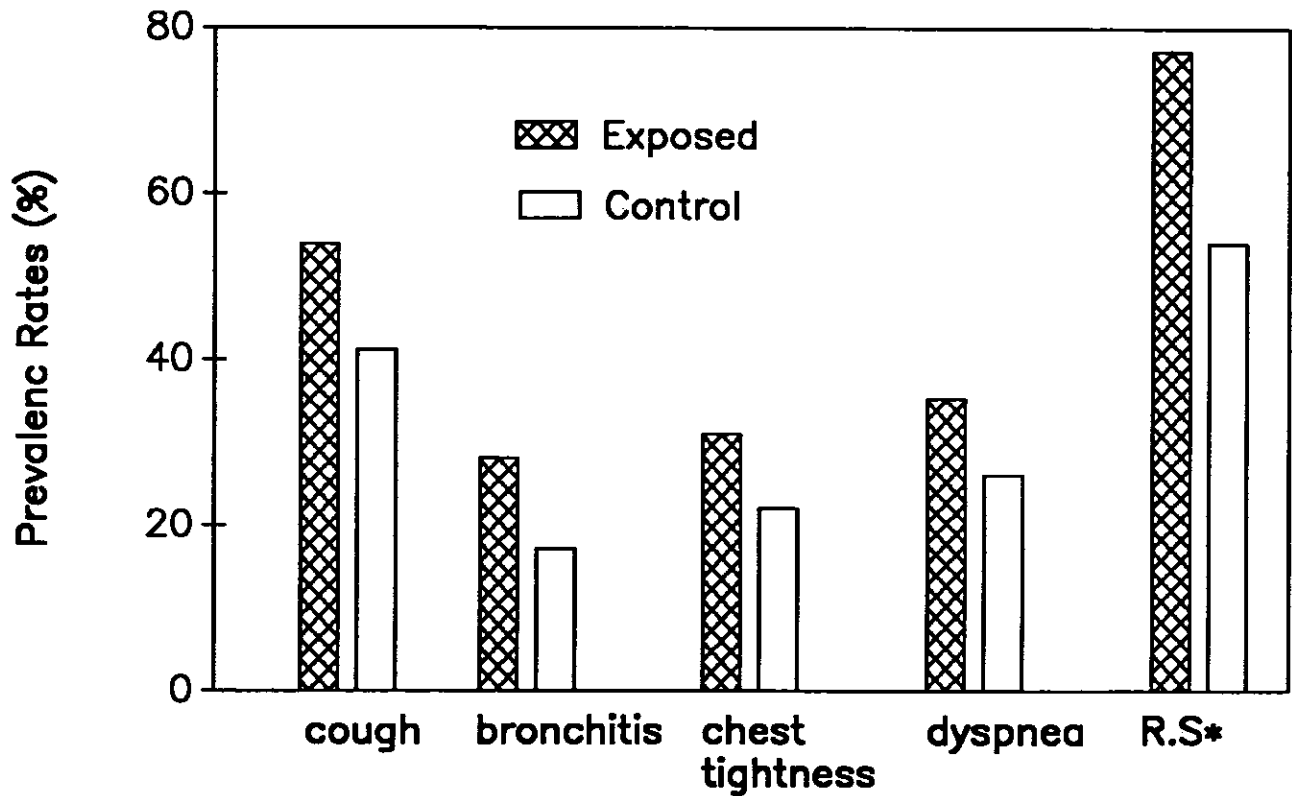

R.S: any of the four respiratory symptoms.

Figure 1. The prevalence of respiratory symptoms in male smokers.

Table II
Comparison of Rates of Abnormality of Percentage of Predicted Value of FVC, FEV_{1.0}, FEV_{1.0}/FVC between Exposed and Control Workers

Lung function values	Percent predicted	Exposed workers		Control workers		X ²	P
		No.	%	No.	%		
FVC	>0.80	331	93.5	356	96.7	4.1	<0.05
	<0.80	23	6.5	12	3.3		
FEV _{1.0}	>0.80	276	78.0	334	90.8	22.7	<0.01
	0.60-0.79	59	16.7	27	16.7		
	<0.60	19	5.4	7	1.9		
FEV _{1.0} /FVC	>0.75	328	89.8	358	97.3	26.1	<0.05
	<0.75	36	10.2	10	2.7		

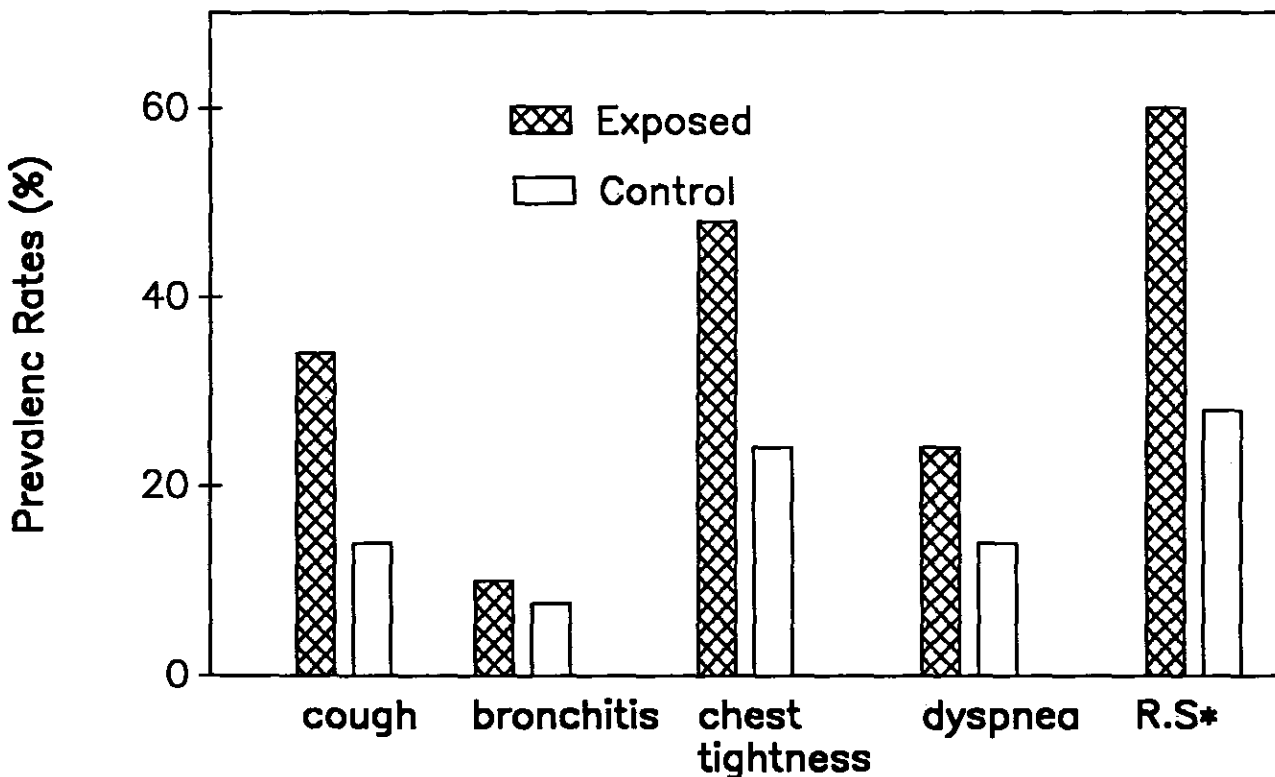

R.S: any of the four respiratory symptoms.

Figure 2. The prevalence of respiratory symptoms in male nonsmokers.

Table III
Contribution* of Dust Exposure and Smoking to Lung Dysfunction Expressed by Abnormal Rate of Percent of Predicted Value of FEV_{1.0}

Dust exposure	Smoke	Abnormal rate of FEV _{1.0}		Odd ratio (OR)
		<0.80	>0.80	
-	-	5	58	1.00
-	+	13	149	1.01
+	-	10	37	3.14
+	+	45	111	4.70

* $OR_{dust+smoking} = 4.15$ $OR_{dust+smoking} = 4.70$
 $OR_{dust+smoking} > OR_{dust} + OR_{smoking}$

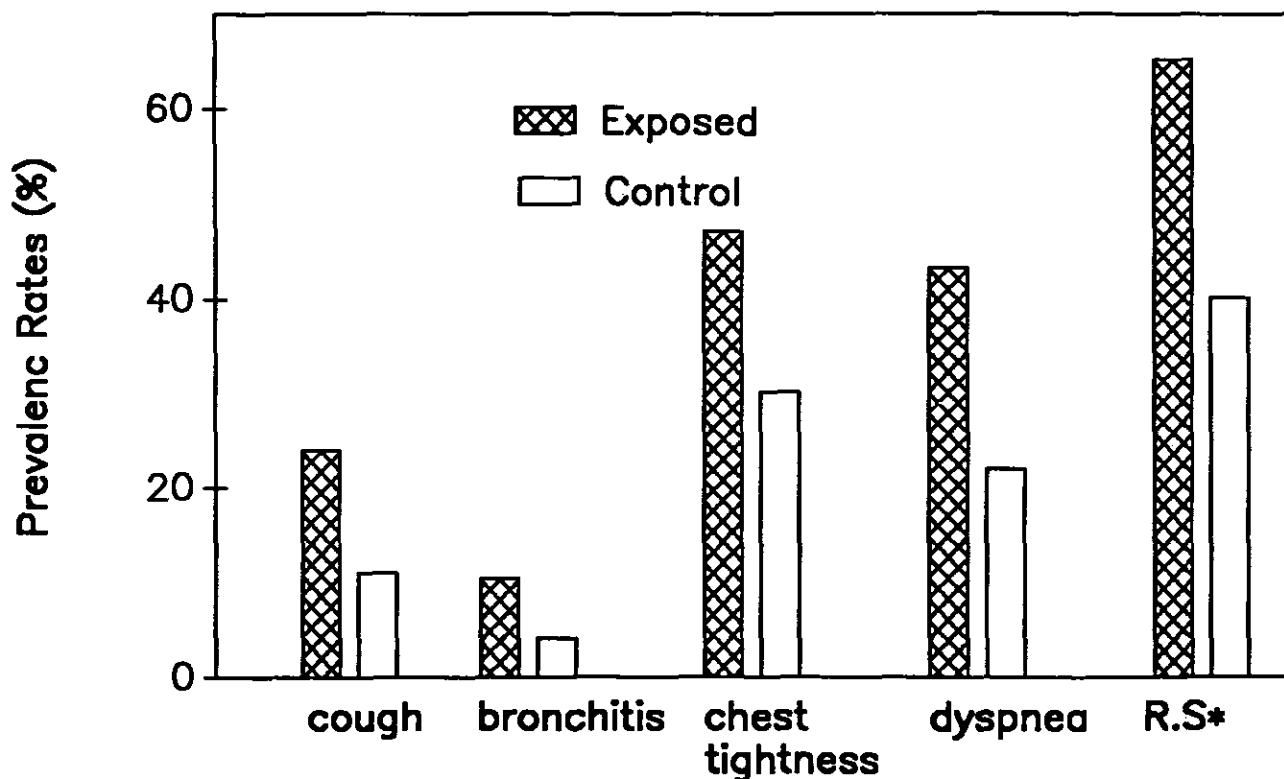

R.S: any of the four respiratory symptoms.

Figure 3. The prevalence of respiratory symptoms in female nonsmokers.

exposed workers, cough and chest tightness not only occurred on Monday, but also occurred in other working days. Smoking itself only caused a higher prevalence rate of cough in both exposed and control groups. With dust exposure, smoking caused a higher prevalence of chronic bronchitis. This means smoking was not the main cause of all these symptoms. The atypical chest tightness and chronic bronchitis were the main clinical symptoms in jute processing workers. There was no typical "Monday" symptom in our study. These findings were similar to the report from Ghawabi, E. L. et al.⁶

Valic, F. et al reported acute lung function loss in nonsmoking female jute workers.⁷ Ghawabi et al, Gandevia and Milne found the acute decline of FEV_{1.0} in the first working shift in jute processing workers.^{6,8} We also found jute processing workers had significantly higher abnormal rates of FVC, FEV_{1.0}, FEV_{1.0}/FVC before the beginning of first working day. The abnormal rate of FEV_{1.0} increased more than 12.9% and rate of severe abnormality of FEV_{1.0} increased more than 3.5% in exposed workers when comparing with control workers. The reasons of difference of results between ours and Mair, A. et al may be due to higher dust levels in our study and different lung function index used. Our results indicated that there is an occupational lung disease problem in China jute industry.

Beck, G. J. et al reported cotton dust and smoking have com-

bined effect in causing the lung function loss.¹¹ We had also found that jute dust and smoking has such an effect. Jute dust exposure was a main cause for abnormality of lung function, but smoking would increase the abnormal rate of lung function caused by dust exposure. We, therefore, concluded that the chronic lung injury in jute processing workers may be mainly due to high level and long duration of jute dust exposure. Our results of industrial hygiene investigation show that jute processing is a very dusty industry. The early steps of processing of jute, especially the mixing and softening procedures produced high levels of dust which contained considerable amounts of ash and silica. The results of high levels of dust in these areas was from manual operation, and high content of ash and silica were associated with earth or dirt on the surface of jute fiber. The other procedures also produced about 2 to 5 mg/M³ dust and most of the dusts were inhalable. The concentration was also higher than the ACGIH recommendation for cotton dust. The jute processing workers, therefore, inhaled a considerable amount of dust, which may account for their lung injury.

The mechanisms of lung disease caused by vegetable dust are very complicated because dust in the workplace is complex. Mineral impurities, special chemical component of fiber and microorganisms are commonly believed to be main etiological factors. In our study, we found there were different mineral and silica contents in different workplaces. A few jute

processing workers were exposed to dust containing 10% to 15% silica, but most workers were exposed to dust containing less than 5% silica. We analyzed the relationships between the mineral content, silica content in dusts and respiratory symptoms and lung function, no relationship was found, all correlation coefficients were below 0.50. The chest X-ray examination of workers who had worked in high level dust areas in this mill for more than 20 years showed no diagnosable silicosis or pneumoconiosis.¹⁴ In our study, there was no evidence that mineral and silica content in jute dust were important factors in jute dust induced lung injury. The mechanism of jute dust induced lung injury may be due to special chemical components of fiber or microorganism, or it may be simply a nonspecific respiratory irritant.³ Further study is needed to better understand the mechanism of lung injury produced by jute dust.

We concluded that jute processing is a very dusty industry. Exposure to jute dusts caused significant increase in respiratory symptoms and significant increase of abnormal rate of FVC, FEV_{1.0}, FEV_{1.0}/FVC. Smoking had an additive effect in lung function injury.

REFERENCES

1. WHO.: *Recommended Health-based Occupational Exposure Limits for Selected Vegetable Dusts*. WHO Technical Report Series 684, Geneva (1983).
2. Rylander, R., Schilling, R.S.F., Pickerig, C.A.C., Dempsey, A.N., Jacobs, R.R.: Effect after Acute and Chronic Exposure to Cotton Dust: the Manchester Criteria. *Brit. J. Ind. Med.* 44:577-579 (1987).
3. Schilling, R.S.F.: Worldwide Problems of Byssinosis. *Chest. supplement* 79:3S-5S (1981).
4. Mair, A., Smith, D.H., Wilson, W.A., Lockhart, W.: Dust Diseases in Dundee Textile Workers. *Brit. J. Ind. Med.* 17:272-278 (1960).
5. Gilson, J.C., Stott, H., Hopwood, B.E.C., Roach, S.A., Mckeerrow, C.B., Schilling, R.S.F.: Byssinosis: The Acute Effect on Ventilatory Capacity of Dusts in Cotton Gineries, Cotton, Sisal, and Jute Mills. *Brit. J. Ind. Med.* 19:9-18 (1962).
6. Ghawabi, E.L.S.H.: Respiratory Function and Symptom in Workers Exposed Simultaneously to Jute and Hemp. *Brit. J. Ind. Med.* 35:16-20 (1978).
7. Valic, F., Zusin, E.: A Comparative Study of Respiratory Function in Female Nonsmoking Cotton and Jute Workers. *Brit. J. Ind. Med.* 28:364-368 (1971).
8. Gandevia, B., Milne, J.: Ventilatory Capacity on Exposure to Jute Dust and the Relevance of Productive Cough and Smoking to the Response. *Brit. J. Ind. Med.* 22:187-195 (1965).
9. Schilling, R.S.F.: Long Term Respiratory Disability in Cotton and Flax Workers. *Lancet*. part 2:330 (1982).
10. Beck, G.C., Schacter, E.N.: The Evidence for Chronic Lung Disease in Cotton Textile Workers. *Am. Stat.* 37: 404-412 (1983).
11. Beck, G.J., Maunder, L.R., Schacter, E. Neil.: Cotton Dust and Smoking Effects on Lung Function in Cotton Textile Workers. *Am. J. Epidemiol.* 119:33-43 (1984).
12. Elwood, P.C., Sweetnam, P.M., Bevan, C.: Respiratory Disability in Ex-cotton Workers. *Brit. J. Ind. Med.* 43:580-586 (1986).
13. Elwood, J.H., Elwood, P.C., Stanford, F., Chivers, A., Hey, Iris-Brewster, L., Sweetnam, P.M.: Respiratory Symptoms in Ex-flax Workers. *Brit. J. Ind. Med.* 43:300-306 (1986).
14. Chen, Z., Jiezhi, L., Zenlin, L.: Comparison of Chest X-ray and Lung Function Changes in Jute Processing Workers. (to be published)

RELATIONSHIP BETWEEN SERUM LIPID PEROXIDES AND SOME IMMUNOLOGICAL PARAMETERS IN SILICOSIS

E. TUFANOIU* • Silvia Gabort† • Ligia Bochisiu*

*County Hospital Deva

†Institute of Hygiene and Public Health, Cluj-Napoca, Romania

In various environmental conditions (xenobiotics, irradiation, hyperoxia), during oxido-reducing metabolic processes,^{11,12,22} and in case of some pathologic processes with generation of circulating immune complexes or ischaemia,^{1,19} activated reactive oxygen forms as superoxide, hydroxyl radicals, singlet oxygen and hydrogen peroxides are produced. These free radicals interact with all tissues, especially with cellular membrane polyunsaturated fatty acids, inducing by chain reactions lipid peroxide release (mainly alkoxy-RO• and peroxy-ROO• radicals), and derivate components as malondialdehyde (MDA), lipidic alcohols, lipofuscin.^{2,5,9,12} The peroxidation of membrane lipids and the by-products of MDA type modify and/or destroy cellular membranes and cause impairment of biological functions and structures: enzyme inactivation, increased rigidity, polymerization and formation of cross linkings between various components (aminic groups of proteins, phospholipids, glycoproteins). In case that biochemical lesions are not reversible, the death of the cells occurs.^{2,11}

Lipid peroxidation is involved in the pathogenesis of numerous lung diseases such as: certain forms of lung edema,^{11,20,26} lung fibrosis,^{15,18} lung cancer,^{15,22} emphysema and bronchitis,^{11,18} hyaline membrane disease,^{4,24} and experimental silicosis.^{13,14,16}

Up to certain limits the damaging effects of oxygen radicals are counteracted by a number of intracellular detoxifying agents, including the antioxidant defense enzyme systems: superoxide dismutase, catalase, glutathione peroxidase, glutathione S-transferases. A nonenzymatic defense equipment—vitamins A, E, C, thiol groups—is also capable of decreasing oxygen free radicals.^{6,9,17}

On the other hand, involvement of immune and inflammatory systems in the fibrogenic response is now well documented; however, its precise role remains to be defined.²¹ The extent to which immunological mechanisms are directly or indirectly involved in the silicotic fibrosis initiation and/or propagation is very unclear. Various non-specific alterations of immune functions, mainly augmentation of humoral immunity have been reported in silicotic patients.^{7,10} Stimulation of immunoglobulin production in response to quartz might result from the effects of secreted by macrophages Interleukin-1, or from the activated helper T-lymphocytes.⁸ Concomitant generation of reactive oxygen metabolites, as specific mediators released by stimulated inflammatory cells, represents one of the effector mechanisms in modulating im-

munologic responses.¹⁰

Most of the data that have been published concerning lipid peroxidation under dust action result from experimental studies. There is no report on lipid peroxide levels in silicotic patients. Therefore, the purpose of the present study was to investigate serum lipid peroxides in silicotic subjects. We attempted also to explore whether lipid peroxidation correlates with the humoral immune response.

MATERIAL AND METHODS

The investigation was carried out on 40 silicotic miners and on 40 healthy subjects, both groups having a matched-mean age. Serum lipid peroxides were measured by the formation of malondialdehyde, using thiobarbituric acid (TBA) method, and spectrophotometric readings.²⁵ The serum immunoglobulins (IgA, IgG, and IgM), and the complement were assayed with the simple radial immunodiffusion, by means of immunoplates supplied by the Cantacuzio Institute in Bucharest.

The results obtained on silicotics were compared to findings of control group by using Student's t-test. A correlation between lipid peroxide and immunoglobulin values was calculated.

RESULTS AND DISCUSSION

An increase of serum lipid peroxides in silicotic subjects compared to control group was noticed (Figure 1). The mean value in silicosis was 5.8 ± 1.6 nmol MDA/0.5ml serum versus 3.02 ± 1.02 nmol MDA/0.5ml serum of control group. The difference was of high significance ($p < 0.001$). The increase of lipid peroxidation is not surprising as the conditions exist in favour of forming them through the persistence of the antigenic stimulus. This stimulus induces a continuous release of oxygen activated metabolites, with the formation of peroxides, especially hydroperoxides and leukotrienes with chemotactic effect,⁹ emphasizing the inflammation, and further generating larger influx of oxygen radicals. There is worth mentioning also the presence of the ischaemic process which strengthens along with the disease progression, and which may have two consequences: (1) the conversion of xanthine dehydrogenase into xanthine oxydase,¹⁹ and, (2) the diminution of the reduced glutathione which acts in cooperation with glutathione S-transferases.^{5,11}

The assay of immunoglobulins revealed a significant increase ($p < 0.001$) of IgG component when compared to normal values found in healthy control group (Figure 2). The mean level of IgG in silicosis was 270 ± 59.75 UI/ml serum, while in control group the mean level reached only 150 ± 50 UI/ml serum. No differences of IgA and IgM globulins as well as of serum complement were noticed between silicotic and control groups. A positive correlation, shown in Figure 3, was registered between the levels of serum lipid peroxides and those of the IgG. This finding could be explained by the fact that biochemical abnormalities and lung tissue modifications led to non-self structures with immunogene properties. The possibility of further perpetuation of this mechanism induced by chain release of free radicals exists in conditions of persistent antigenic stimulus exerted by quartz activated inflammatory cells. This could be the "primum movens" in the starting of autoimmune mechanisms.

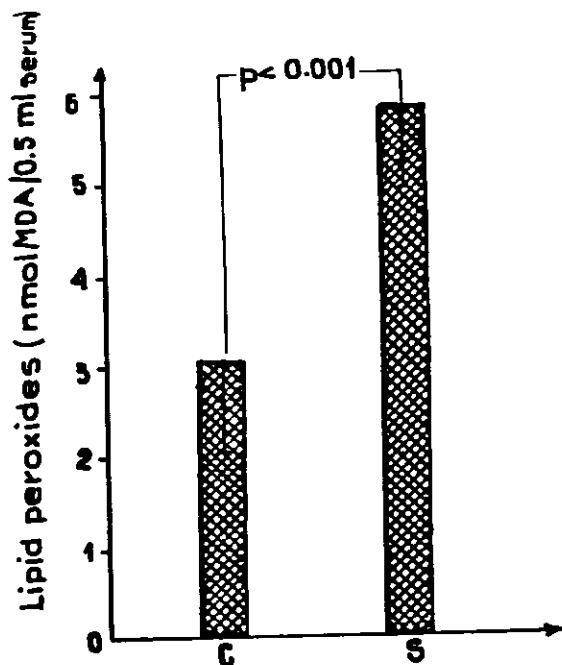

Figure 1. Serum lipid peroxides in silicotic patients.

The involvement of oxygen free radicals in collagen accumulation by non-immune mechanisms is also pertinent. This effect may occur through the nonenzymatic hydroxylation of proline to hydroxyproline with the edification of hydrogen bindings among peptidic chains and their association in tricatenary helicoid structures.^{3,21} Subsequent increased collagen synthesis and fibrotic nodule results. The findings that the anticancer drugs such as bleomycine, anthracyclines and some nitrofuranes produce oxygen radicals, inducers of fibrosis,^{11,21,23} support the hypothesis that a same mechanism may also operate in silicotic fibrosis.

In conclusion, this study confirms that free radical-induced lipid peroxidation might be of particular significance in the development of silicosis in humans, and, thus, could hold a perspective to new therapeutic measures.

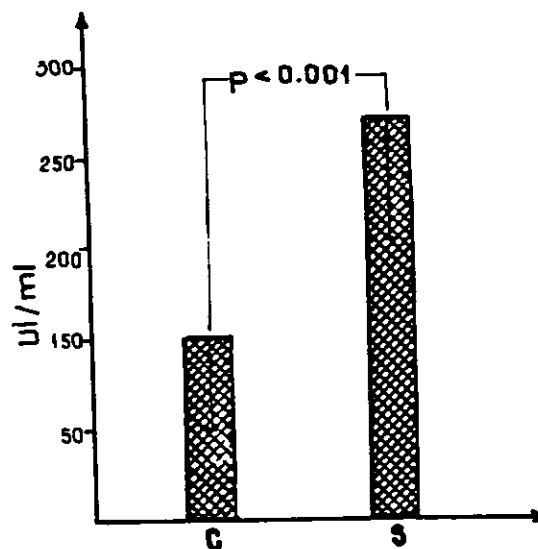

Figure 2. Serum immunoglobulin IgG in silicotic patients.

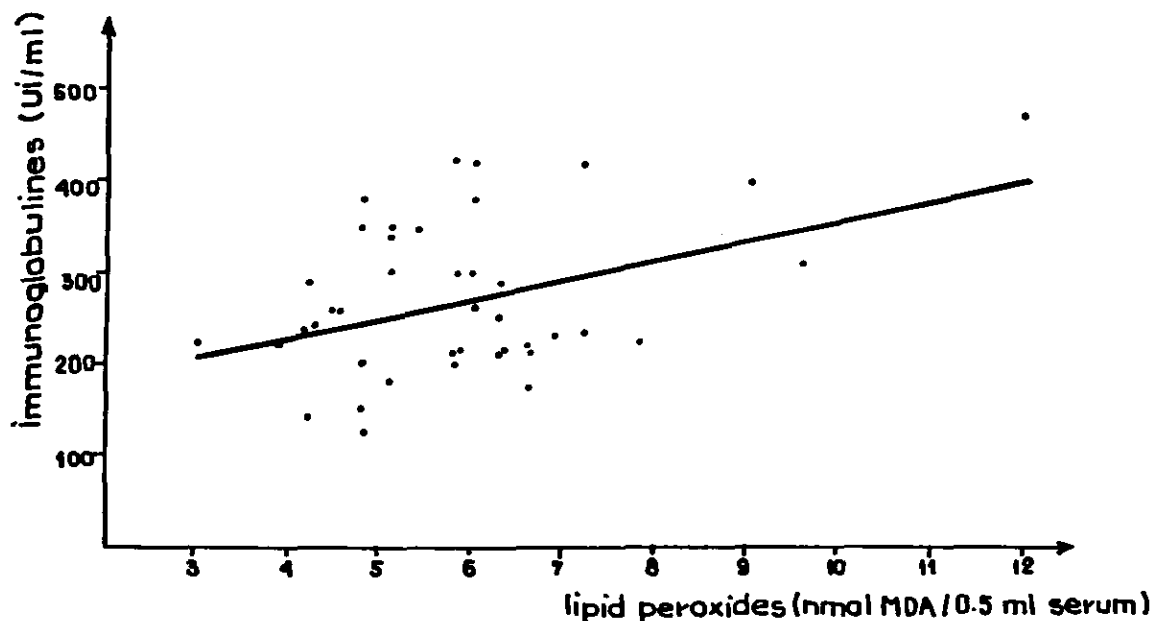

Figure 3. Correlation between serum lipid peroxides and immunoglobulin IgG in silicotic patients, $R=0.444$, $p < 0.01$.

REFERENCES

- Abramson, S., Weissmann, G.: The Release of Inflammatory Mediators from Neutrophils. *Ricer. Clin. Lab.* 2:91-99 (1981).
- Armstrong, D.: Free Radical Involvement in the Formation of Lipopigments. *Free Radicals in Molecular Biology, Aging and Disease*. pp.129-141, Armstrong, D. et al eds. Raven Press, New York (1984).
- Borel, J.P.: Radicaux Libres Oxygénés, Tissu Conjonctif et Inflammation. *Path. Biol.* 1:8-10 (1983).
- Brown, R.E., Craver, R., Drake, M.: Lipid Peroxidation and Pulmonary Hyaline Membranes of the New Born. *Ann. Clin. Lab.* 1:25-29 (1981).
- Burk, F.R.: Glutathione-Dependent Protection by Rat Liver Microsomal Protein Against Lipid Peroxidation. *Biochim. Biophys. Acta* 757:21-28 (1983).
- Capel, I.D., David, L., Helen, M., Dorre, L.L.: Vitamin E Retards the Lipoperoxidation Resulting from Anticancer Drug Administration. *Anticancer Res.* 3:59-62 (1983).
- Cocarla, A., Gabor, S., Milea, M., Suci, I.: Serum Immunoglobulines in Workers Exposed to Silicogenic Risk with Tuberculin-Negative Test and Hyperergia. *J. Hyg. Epidemiol. Microbiol. Immunol.* 4:374-380 (1977).
- Davis, G.S.: The Pathogenesis of Silicosis. State of the Art. *Chest* 89:166S-169S (1986).
- DelMaestro, R.F.: Free Radical Injury During Inflammation. *Free Radicals in Molecular Biology, Aging and Disease*. pp. 87-101. Armstrong, D. et al eds. Raven Press, New York (1984).
- Fantone, J.C., Feltner, D.E., Brieland, J.K., Ward, P.A.: Phagocytic Cell-Derived Inflammatory Mediators and Lung Disease. *Chest* 91:428-435 (1987).
- Frank, L.: Superoxide Dismutase and Lung Toxicity. *Trends Pharmacol.* 3:124-128 (1983).
- Freeman, A.B., Crapo, J.D.: Free Radicals and Tissue Injury. *Lab. Invest.* 5:412-426 (1982).
- Gabor, S., Frits, T., Anca, Z.: Taux des Lipoperoxydes dans le Poumon et le Myocarde Droit dans la Silicose Experimentale chez le rat. *Arch. Mal. Prof.* 32:553-558 (1974).
- Gabor, S., Anca, Z., Zugravu, E., Ciugdeanu, M.: In Vitro and Vivo Quartz-Induced Lipid Peroxidation. *The In Vitro Effects of Mineral Dusts*. pp.131-137, R.C. Brown, M. Chamberlain, R. Davies, I.P. Gormley eds. Academic Press. London (1980).
- Gulumian, M., Sardanios, F., Kilroe-Smith, T., Ockerse, G.: Lipid Peroxidation in Microsomes Induced by Crocidolite Fibers. *Chem. Biol. Interact.* 44:111-118 (1983).
- Gupta, G.S., Kaw, J.L.: Formation of Lipid Peroxides in the Subcellular Fractions of Silicotic Lungs in Rats. *Eur. Respir. Dis.* 63:183-187 (1982).
- Jenkins, S.G., Lawrence, R.A., Tucker, W.Y.: Glutathione Peroxidase, Superoxide Dismutase, and Glutathione S-Transferase Activities in Human Lungs. *Am. Rev. Respir. Dis.* 130:302-304 (1984).
- Kopferschmitt, J., Ledig, J.M., Jaeger, A., Sauder, Ph., Warter, A., Ziessel, M., Mantz, J.M.: Variations de la Superoxyde Dismutase Pulmonaire en Pathologie Humaine. *La Presse Méd.* 12:46 (1983).
- McCord, M.J.: Oxygen-Derived Free Radicals in Postischaemic Tissue Injury. *New Engl. J. Med.* 3:159-163 (1985).
- Parker, J.C., Martin, D.J., Rutili, G., McCord, M.J., Taylor, A.E.: Prevention of Free Radical Mediated Vascular Permeability Increases in Lung Using Superoxide Dismutase. *Chest* 83:5-53s (1983).
- Phan, S.H.: Fibrotic Mechanisms in Lung Disease. *Handbook of Inflammation. Immunology of Inflammation.*, vol. 4, pp. 121-162. P.A. Ward ed., Elsevier, Amsterdam-New York-Oxford (1986).
- Pryor, W.A.: Free Radical Biology: Xenobiotics, Cancer, and Aging. *Ann. New York Acad. Sci.* 227:1-21 (1982).
- Revis, N.W., Marusic, N.: Glutathione Peroxidase Activity and Selenium Concentration in the Heart of Doxorubicin-Treated Rabbits. *J. Molec. Cellul. Cardiol.* 10:945-951 (1978).
- Rosenfeld, W., Evans, H., Jhaveri, R., Moanie, H., Vohra, K., Georgatos, E., Salazar, J.D.: Safety and Plasma Concentration of Bovine Superoxide Dismutase Administered to Human Premature Infants. *Rev. Pharmacol. Ther.* 5:151-161 (1982).
- Satoh, K.: Serum Lipid Peroxide in Cerebrovascular Disorders Determined by a New Colorimetric Method. *Clin. Chim. Acta* 90:37-43 (1978).
- Taylor, A.E., Martin, D., Parker, J.C.: The Effects of Oxygen Radicals on Pulmonary Edema Formation. *Surgery* 3:443-438 (1983).

RAMAN SPECTROSCOPIC STUDIES ON THE MECHANISMS OF MEMBRANE DAMAGE INDUCED BY QUARTZ AND THE PROTECTIVE EFFECT OF ALUMINIUM CITRATE

CHENG J. CAO,* M.D. • Shi J. Liu,* M.D. • Ke C. Lin,† Ph.D.

*Dept. of Occupational Health, School of Public Health

†Dept. of Biophysics, School of Basic Medicine Beijing Medical University, 100083, Beijing, China

ABSTRACT

The molecular mechanisms of membrane damage induced by quartz and the antagonistic effect of aluminium citrate (Al citrate) against its toxicity were studied with liposomes by laser Raman spectroscopy. Liposomes under the action of quartz represented a Raman spectrum, in which the choline band shifts about 2-3 cm^{-1} toward the lower frequency and its intensity reduces, while its width increases; the intensity ratio of 1127 cm^{-1} to 1093 cm^{-1} bands decreases, so does the intensity ratio of 2883 cm^{-1} to 2847 cm^{-1} bands. These results show that quartz can react on phospholipids and form a stable complex with their polar head groups, $-\text{N}+(\text{CH}_3)_3$. The change of hydrocarbon chain conformation is caused by the interaction of quartz with the heads of phospholipids and deformation of liposomes. However, the similar change of choline groups cannot be found in Raman spectrum of liposomes under quartz pretreated with Al citrate or AlCl_3 , and the order of hydrocarbon chain remains constant. The fact indicates further that Al citrate can exhibit its protective effect on membranes through the action of Al on the surface of quartz particles so that the direct interaction of quartz with lipidic molecules was blocked. As for titanium dioxide, it acts on liposomes too weak to cause any change of Raman spectrum, which is consistent with its weaker damage to the membranes.

INTRODUCTION

The injurious effect of quartz on cell membranes plays an important role in the pathogenic mechanism of silicosis. The significant effects of quartz on the functional and structural properties, such as fluidity, permeability, "water structure" and surface charge, of cell membranes as well as liposomes and the antagonistic effects of Al citrate were demonstrated in a series of our earlier experiments.¹⁻⁴ However, their molecular mechanisms remain to be clarified. For this reason, the studies of interactions of quartz, titanium dioxide and Al citrate with liposomes were carried out by laser Raman spectroscopy.

The use of Raman spectroscopy as a tool for research on the function and structure of membranes is a rapidly growing field. The quantitative molecular interpretations of the spectral events accompanying conformational alternations can be studied by this technique. Liposomes are often taken as a model for biomembranes because lipids in biomembranes are usually in a bilayer form. In the present study, we used dipalmitoyl-phosphatidylcholine (DPPC) to prepare liposomes due to its definite assignment of Raman bands.

In light of the finding that the injurious effect of quartz on membranes was lowered markedly by the pretreatment of these particles with Al citrate,¹⁻⁴ the present study was concentrated on the observations of Raman spectral effect of this pretreatment to elucidate its pharmacology.

MATERIALS AND METHODS

1. Quartz (99% pure) was supplied by Hygiene Institute of Chinese Prophylactic Medical Center. Titanium dioxide with a similar pure and size was obtained from Beijing Medical Chemical Factory. Al citrate with Al of 9.26% was supplied by Pharmaceutical Factory of Beijing Medical University. Quartz particles were pretreated with Al citrate or AlCl_3 using the method reported by Zou, T.T. et al.⁵⁻⁶ DPPC was purchased from Sigma. Liposomes were prepared at the concentration of 100 mg/ml using the method described previously.
2. Raman spectra were obtained with Trimonochrometer Raman Spectrometer Model YJT-800. The 5145 Å line of the laser was selected as excitation. The used power was 400-500 mw. Spectral slit width and scanning velocity were 800 μm and 1 $\text{cm}^{-1}/\text{sec}$, respectively. The computer was used to average signal, which was accumulated about 4-6 times. Spectra were not smoothed and only baseline was modified appropriately. Variance of sharp peaks were no more than 2 cm^{-1} . Qualitative and quantitative analysis of the data were evaluated by the intensity ratio and order parameters to avoid interference.

RESULTS

C-N Band

715 cm^{-1} band in DPPC is the C-N stretching mode. The 1295 cm^{-1} bands are assigned to twisting and bending vibration modes of C-H, respectively, which are often utilized as an internal standard of C-N bands due to their high intensity and their insensitivity to environmental factors.

As shown in Table I and Figure 1, the 715 cm^{-1} band shifted about 2-3 cm^{-1} toward the lower frequency and its intensity was decreased markedly in DPPC+quartz group. As compared to DPPC control group, the intensity ratio of 715 cm^{-1} band to 1295 cm^{-1} or 1437 cm^{-1} band was reduced by 26.6% and 30.5% in 0.5 mg of quartz, respectively, while the reductions were more significant, that is 31.6% and 40.3%, respectively. Figure 2, the enlarged C-N band, illustrates clearly that the width of C-N peak was increased in DPPC+quartz group. However, these changes of C-N band caused by quartz almost

disappeared by the pretreatment of quartz particles with Al citrate or AlCl_3 . (Table I and Figures 1-2)

C-C Skeletal Structure

The skeletal optical modes in 1000-1200 cm^{-1} region include generally C-C and P-O stretching vibrations. Three principal bands to be used to estimate the intrachain order exist in this region. Figure 1 represents the Raman spectra in 1040-1150 cm^{-1} region of DPPC groups and its treated groups. The data listed in Table II show that quartz can decrease the intensity ratio of 1127 cm^{-1} to 1093 cm^{-1} bands and the intrachain parameter S_T , particularly in its 1.0 mg group, S_T was reduced by 21.6% compared to DPPC control. Whereas the pretreatment of Al citrate or AlCl_3 for quartz can partly reverse the effect of quartz, S_T tended to go upwards. In contrast to quartz, these parameters did not change significantly in DPPC+titanium dioxide group, which means titanium dioxide cannot interfere with C-C skeletal structure of phospholipid membranes.

Table I
The Shift of C-N Band and Its Intensity Ratio
to 1295 or 1437 Bands

Group	C-N cm^{-1}	I CN / I 1295 cm^{-1}		I CN / I 1437 cm^{-1}	
	\bar{x}	\bar{x}	%	\bar{x}	%
control	715.2	0.79	100.0	0.62	100.0
quartz (0.5mg)	713.2	0.58	73.4	0.43	69.5
(1.0mg)	712.4	0.54	68.4	0.37	59.7
quartz pretreated with Al citrate	715.2	0.79	100.0	0.57	91.9
quartz pretreated with AlCl_3	714.6	0.78	98.7	0.58	93.5
titanium dioxide	714.8	0.80	101.3	0.61	98.4

The doses of the pretreated quartz and titanium dioxide were 1.0 mg.

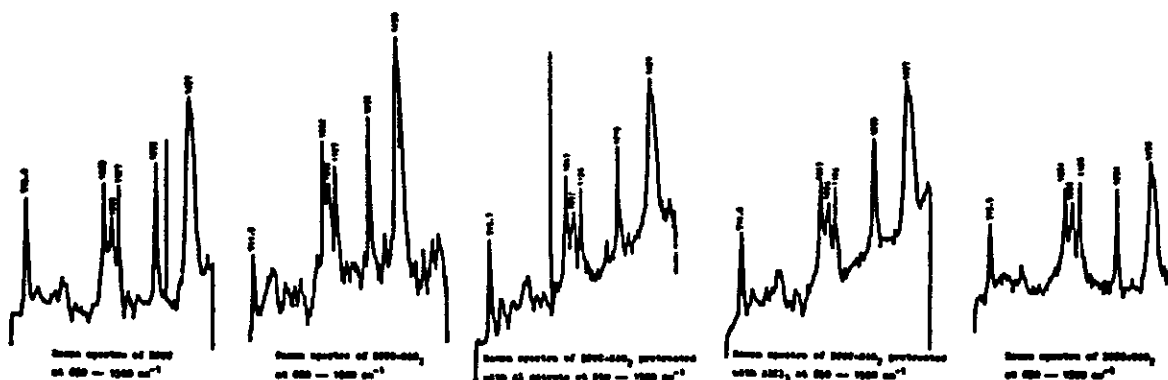

Figure 1.

C-H Stretching Vibration

The C-H stretching in 2800-2900 cm^{-1} region includes mainly the methylene symmetric stretch (2847 cm^{-1}) and asymmetric stretch (2882 cm^{-1}), which are used to evaluate the lateral packing order.

It can be seen from Table III and Figure 3 that the intensity ratio of 2882 cm^{-1} to 2847 cm^{-1} bands and the lateral order parameter S_L were lowered largely in two doses of quartz. Of interest, the intensity ratio and S_L values were enhanced markedly in both these pretreated groups, indicating that the interchain packing order was recovered partly. Likewise, there was no alternation in Raman spectrum in 2800-2900 cm^{-1} region of DPPC+titanium dioxide group. These findings suggest that titanium dioxide acted on liposomes weakly.

DISCUSSION

Raman spectra of lipids reflect mainly the vibrations of polar head group and C-H bonds. The 715 cm^{-1} band is the C-N symmetric stretching vibration mode. C-N group was even taken as an internal standard because it is constant and does not appear in the difference spectra.⁷ It will be, therefore, a

matter of great interest once the group has changed. The frequency of C-N band shifted, its intensity decreased and its width enlarged in DPPC under the action of quartz. This fact indicates that C-N group is an important site with which quartz interacts in membranes.

There a number of hydroxy groups on the surface of hydrated quartz, and silicic acid can be hydrolyzed partly to HSiO_3^- in pH between neutral and alkaline due to its PK_1 .¹⁰⁻¹ Whereas phospholipids of membranes rich in choline groups charged positively, which seems to provide HSiO_3^- with a "target group," and a potential polar or ionic bond between N and O may be formed, resulting in their electrostatic and hydrophilic interactions.

The distinct changes of C-N band in Raman spectrum implicate that this binding is rather tight. According to this, it is explained why quartz can alter electrophoretic behaviour of macrophages and increase their negative charge density.³ Also, the unhydrolyzed -OH groups of quartz surface form probably a hydrogen bond with $> \text{P}_2^-$ of phospholipid. On the other hand, deformation of liposomes to fit the globular surface of quartz particles may produce many binding sites

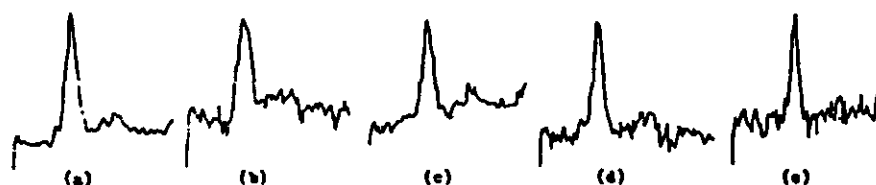

Figure 2. The enlarged C-N Raman band of DPPC (a), DPPC+SiO₂ (b), DPPC+SiO₂ pretreated with Al citrate (c), DPPC+SiO₂ pretreated with AlCl₃ (d), and DPPC+TiO₂(e).

Table II
The Intensity Ratio of 1127 to 1093 Bands and
Order Parameter (S_T)

Groups	I 1127 cm^{-1} / I 1093 cm^{-1}	S_T	
		\bar{x}	%
Control	1.36	0.74	100.0
quartz (0.5 mg)	1.24	0.68	91.9
(1.0 mg)	1.07	0.58	78.4
quartz pretreated with Al citrate	1.14	0.62	83.8
quartz pretreated with AlCl ₃	1.17	0.64	86.5
titanium dioxide	1.39	0.76	102.7

The doses of the pretreated quartz and titanium dioxide were 1.0 mg.

Table III
The Intensity Ratio of 2882 to 2847 Band and Order Parameter (S_L)

Groups	I 2882 cm^{-1} / I 2847 cm^{-1}	S_L	
	\bar{x}	\bar{x}	%
Control	1.04	0.23	100.0
quartz (0.5 mg)	0.87	0.11	47.8
quartz (1.0 mg)	0.90	0.13	56.5
quartz pretreated with Al citrate	1.02	0.21	91.3
quartz pretreated with AlCl_3	1.03	0.22	95.7
titanium dioxide	1.04	0.23	100.0

The doses of the pretreated quartz and titanium dioxide were 1.0 mg.



Figure 3. Raman spectra of DPPC (a), DPPC+ SiO_2 (b), DPPC+ SiO_2 pretreated with Al citrate (c), DPPC and SiO_2 pretreated with AlCl_3 (d), and DPPC+ TiO_2 (e) at 2800-2900 cm^{-1} .

to force quartz and liposomes to form a tight complex. A good evidence for this is larger changes of bands at 2800-2900 cm^{-1} caused by quartz than that at 1040-1150 cm^{-1} .

The interaction of quartz with polar head group triggered a series of alternations of hydrocarbon chains. Membrane skeletal optical mode exists in 1000-1150 cm^{-1} region in Raman spectrum and is quite sensitive to the configuration of C-C bond. 1062 cm^{-1} and 1127 cm^{-1} bands are originated primarily from all-trans C-C stretching vibration, resulting in a zigzag chain on a plane, whereas 1093 cm^{-1} broad band is contributed by the Gauche vibration, which alters intrachain to a more disorder state. In general, information about the intrachain order and its molecular motion regulation may be obtained from the intensity ratio of 1127 cm^{-1} /11093 cm^{-1} and order parameter S_T .⁷ The decreases in this intensity ratio and S_T resulting from the action of quartz on liposomes indicate a loss in the number of the trans isomers and an abnormal increase in the number of the Gauche isomers, leading to the decreased intrachain order.⁸

The C-H vibration at high frequency region of 2800-2900 cm^{-1} is susceptible to the environmental factors and the

direction of C-H chain. The intensity ratio of I2882 cm^{-1} /I2847 cm^{-1} and order parameter S_L are usually used to estimate the interchain order and its lateral molecular motion pattern.⁷ The decrease of this intensity ratio and S_L induced by Quartz show that the lateral packing order was interfered simultaneously.

The molecular dynamic mechanism postulated in this paper was supported by the comparative studies of titanium dioxide and quartz pretreated with Al citrate or AlCl_3 . It has been demonstrated that the affinity of titanium dioxide for quaternary ammonium group and Al^{3+} is much lower than quartz,⁶⁻⁹ which is related to its hydration ability. Furthermore, titanic acid is so much weaker an acid than silicic acid that it is difficult to be hydrolyzed and to bind with C-N group, and also its ability to form hydrogen bond with $> \text{P}_2$ group is not as high as quartz. That is why titanium dioxide acts weakly on liposomes and no change of Raman spectrum could be found. It is more important that this is consistent with its weak cytotoxicity and its weak effects on cell membranes.

In light of the antagonistic effect of the pretreatment way against membrane damage by quartz, the present paper

centered on the observations of Raman spectroscopic effects of DPPC under the action of quartz particles pretreated with Al citrate or AlCl_3 .

The results show that the changes of the main bands in the Raman spectra are very similar between the two pretreated groups. The frequency, intensity ratio and peak shape of C-N band were almost recovered to the control level. The intensity ratio of $I_{2882} \text{ cm}^{-1}/I_{2847} \text{ cm}^{-1}$ and S_L went up markedly and closed to the control level. Whereas the intensity ratio of $I_{1127} \text{ cm}^{-1}/I_{1093} \text{ cm}^{-1}$ and S_T were recovered only partly, indicating that the molecular degree of intrachain remained partly in the disorder. It seems therefore logical that Al citrate was unable to completely recover the effects of quartz on cell membranes, such as fluidity and permeability, to the control level. Moreover, it has been found that Al citrate did not alone affect Raman spectrum of DPPC in our preliminary experiment. So it is obvious that the effective component by which Al citrate exerts its pharmacological effect is Al itself through the action on the surface of quartz particles.

REFERENCES

1. Cao, C.J.: Investigation of the Effects of Quartz and Aluminium Citrate on Fluidity of Artificial Membranes. *J. Chin. Ind. Hyg. & Occup. Dis.* 3:140 (1983).
2. Cao, C.J.: The Effect of Aluminium Citrate on Permeability of Macrophage Membranes to K^+ Caused by Quartz. *Biochem. Biophys.* 1:39 (1985).
3. Cao, C.J.: The Effects of Quartz and Titanium Dioxide on Electrophoretic Mobility of Guinea Pig Alveolus Macrophages. *J. Chin. Ind. Hyg. & Occup. Dis.* 3:137 (1985).
4. Cao, C.J., Liu, S.J., Lin, K.C.: The Effects of Quartz and Aluminium Citrate on Membrane-bound Water of Erythrocytes. *Acta Biophys. Sinica.* 2:136 (1986).
5. Zou, T.T.: In Vitro Study of the Preventive Effect of Aluminium Citrate Against the Cytotoxicity of Quartz. *Matell. Ind. Hyg.* 6:246 (1982).
6. Cao, C.J.: The Effects of Aluminium Citrate on Electrokinetic Potential on the Surface of Quartz and Titanium Dioxide Particles. *J. Chin. Preven. Med.* 3:143 (1985).
7. Gaber, B.P., Peticolas, W.I.: On the Quantitative Interpretation of Biomembrane Structure by Raman Spectroscopy. *Biochem. Biophys. Acta* 465:260 (1977).
8. Anthony, T. Tu: *Raman Spectroscopy in Biology*. pp. 187. A Wiley Interscience Publications, USA (1982).
9. Depass, J., et al: Comparison between Two Hypothesis about the Physicochemical Basis of the Toxicity of Silica. *J. Colloid Interface Sci.* 60:416 (1977).

STUDY OF FIBROGENIC EFFECTS OF SLAG CEMENT AND ITS RAW MATERIALS ON RAT LUNG

YANG MEIYU • Zhang Jifang • Zhao Xiuqing • Xu Guihua • Fu Bo

Shenyang Research Institute of Industrial Hygiene and Occupational Diseases, Shenyang, P.R. China

ABSTRACT

The fibrogenic effects of slag cement and its raw materials on rat lung and their effects on the survival rate of alveolar macrophages *in vitro* were studied. Seven groups were experimented: slag cement, raw material, ripe material, iron, slag, quartz and control group. 50 mg each of the above mentioned prepared dusts particulates was injected intratracheally into each rat. All rats were killed at an interval of 1, 3, 6 and 12 months. The wet/dry weights of the lung and collagen content of the lung were measured. The histopathological findings of the rat lungs and hilar lymphnodes were observed. The results showed that the raw and ripe materials caused the slight interstitial thickening and an increase of reticulin fibre while slag cement and iron induced an increase of slight collagen fibre, and in case of slag an increase of more collagen fibre was found. The results showed the fibrogenic effect of these dusts *in vivo* were in concordance with the toxicities of these dusts *in vitro*.

No Paper provided.

FEATURES OF CALCIFIED SILICOSIS AND ITS PROGNOSIS

ZHAO JINDUO • Wang Mingqui • Yang Meiyu • Liu Jingde • Win Xiuyun

Shenyang Research Institute of Industrial Hygiene and Occupational Diseases, Shenyang, P.R. China

ABSTRACT

Calcification of silicotic nodules is a special appearance in the development of some patients with silicosis. Because it occurs on the basis of silicotic lesions, so the site and extent of the calcification are in accordance with that of silicotic opacities. The sharply demarcated calcification became denser year by year, and the center of the small opacities were denser than their periphery. Coexistence of calcification of nodules and eggshell calcification of hilar lymphnodes usually concurred, and it is helpful to diagnosis. At autopsy, lung tissue was examined by polarizing microscope, electron probe and EDXA examination and results showed much of silica particles blocked in the calcified areas of the nodules. This might mean retention of particles in the calcified areas, thus, they could not be phagocytosed and transported by phagocytes to other areas, preventing the continuous tissue damage by particles. Therefore, the progress of the silicosis can be prevented with better prognosis. It is reasonable that the calcification of the silicotic nodules is an inactive phase and self-protection process of the silicosis.

No Paper provided.

DEVELOPMENT OF A NEW PERSONAL EXPOSURE MEASUREMENT SYSTEM CONSIDERING PULMONARY VENTILATION

TOSHIKI HIGASHI,* M.D. • Toshihiko Satoh,† M.D. • Haruhiko Sakurai,† M.D., M.P.H. • Yasuhiko Baba,* M.D.

*University of Occupational and Environmental Health, JAPAN, Institute of Industrial Ecological Sciences, Kita-Kyushu, Japan

†Keio University, School of Medicine, Tokyo, Japan

ABSTRACT

The pulmonary ventilation is a critical factor for determining the intake of airborne pollutants. However, the present widely used monitoring for the evaluation of occupational exposures tends to ignore it. We have developed a monitor on experimental basis (HMR-3) with the function of measuring the real-time pulmonary ventilation in order to evaluate the actual exposure level, and presented it at ICOH, Sydney in 1987. On the findings obtained by HMR-3, we developed an improved device (DEM-1) which is sufficient for practical use in size and function.

DEM-1 system consists of four components. (1) Sensors for heart rate, for ambient dust concentration (mini-RAM), for body and environmental temperature, and for acceleration, (2) the data-logger which collects and inputs the data into IC-card, (3) the IC-card reader for the personal computer, (4) soft-wares for data processing. In this system, real-time pulmonary ventilation volume is predicted from average heart rate every 30 seconds using a conversion formula which includes the rate of change in heart rate, age, height and weight for each subject as explanatory variables.

Furthermore, DEM-1 has the following advantages. (1) By replacing the IC-card, the data-logger can be used continuously. (2) Capable of displaying the level of movement by acceleration sensor simultaneously, it is helpful for separately determining the degree of occupational hazards in each working unit.

INTRODUCTION

Exposure evaluation is indispensable for assessing the risk of airborne dusts in the workplace. Presently, when determining the level of individual exposure to airborne dusts, measurements are made by taking a sample from breathing zone. Those methods, however, do not take into account the level of physical exertion during exposure. Physical activity is known to increase pulmonary ventilation by about 10 times the level at rest.^{1,2} Increased pulmonary ventilation causes an increment in the uptake of respirable dusts and affects the amount deposited.³

Thus, measurement of pulmonary ventilation, as well as the air concentration of airborne dusts, could seem to provide highly useful data in evaluating exposure. We have developed an instrument on experimental basis (HMR-3) for measuring exposure to air pollutants that continuously measures the concentration of air pollutants and the ventilation volume simultaneously, and presented it at ICOH, Sydney in 1987.⁴ In this system, real-time pulmonary ventilation volume is predicted from average heart rate every 30 seconds using a conversion formula which includes the rate of change in heart rate, age, height and weight for each subject as explanatory variables. On the findings obtained by HMR-3, we developed

an improved device (DEM-1) which is sufficient for practical use in size and function.

METHODS

Description of the System

Figure 1 shows the system outlines of the device (DEM-1). DEM-1 system consists of four components. 1) Sensors for heart rate, for ambient dust concentration, for body and ambient temperature, and for acceleration, 2) the data-logger which collects and inputs the data into IC-cards, 3) the IC-card reader for the personal computer, 4) soft-wares for data processing.

Dust sensor: This is a mini RAM, a small-sized dust measuring device manufactured by MIE, U.S.A., which measures mass concentrations by a light scatter detector.

Heart rate sensor: Electrodes Vitrode G-80 manufactured by Nihon Kohden Co. is used. The mean of the R-R intervals in a 30-second ECG recording represents the heart rate.

Accelerometer: An accelerometer (MT-3; Nihon Kohden Co.) that picks up changes in the intensity or the form of work

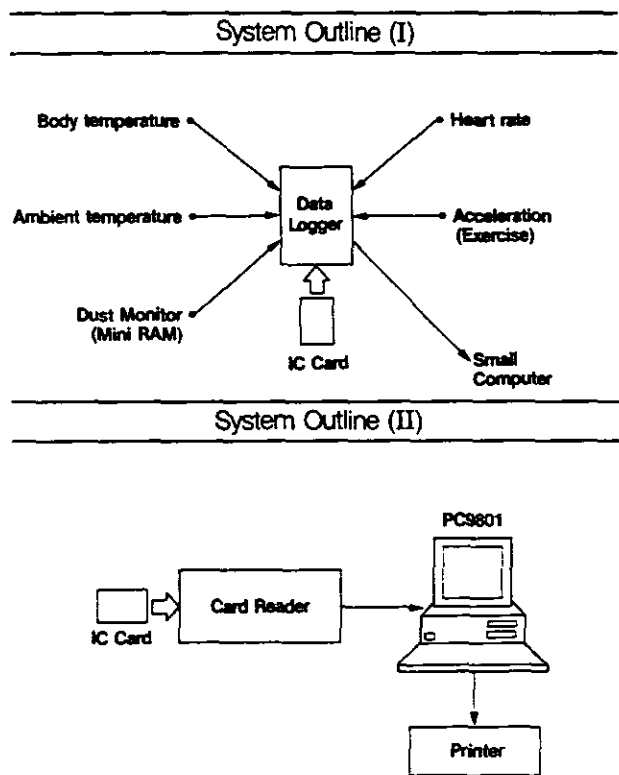

Figure 1. Essential components of DEM-1 and flow chart of data processing.

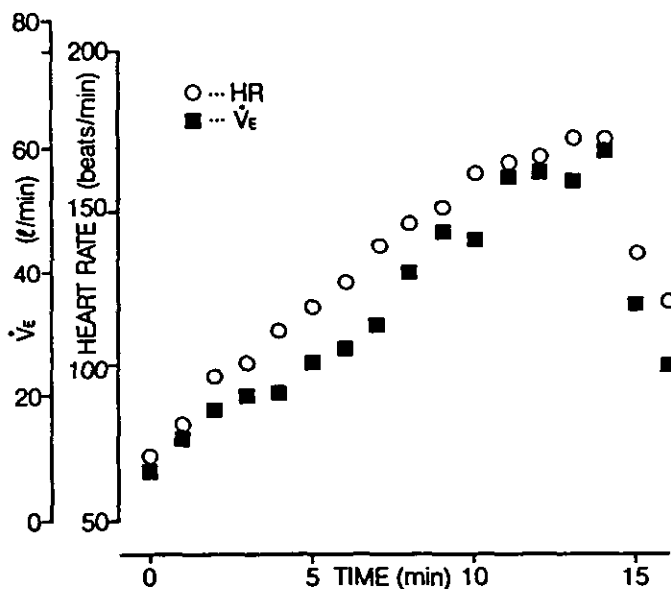

Figure 2. Typical HR response and \dot{V}_E during graded exercise test using a treadmill.

is used as a sensor for physical activity.

Thermo sensor: This body and ambient temperature sensor provides additional ambient data on workers.

Data-logger: Analogue-data output from each sensor are A/D converted by the data-logger and recorded on the IC-card. The data-logger is attached to each worker by an exclusive belt. The measuring time, ID number, measuring channels are input by the keyboard on the surface of data-logger.

IC-card: Digitalized data are recorded on the IC-card, read into the computer by the card reader and processed. Since the IC-card has a memory capacity of 128 K bit and can store data collected during 10 hours, data in all channels are recorded at intervals of 30 seconds.

Card reader: Data recorded on the IC card are recorded into a floppy disk by the card reader connected to the computer.

Personal computer: The hardware (PC-9801, NEC, Japan) includes dual floppy disk drives, color video monitor and color printer as options.

Laboratory Testing of DEM-1 System

For determining the regression equation between the ventilation volume and the heart rate, heart rate and pulmonary ventilation were measured up to submaximal level using treadmill. Heart rate and pulmonary ventilation were measured by using a microcomputer-based respiratory analyzer (Aerobic Processor: NEC-Sanei, Japan).

The subjects were 34 healthy male adults, aged 17 to 62 years. Exercises on the treadmill were gradually increased under controlled conditions to achieve stability at each heart rate level, such as +20%HR, +40%HR, +60%HR and so on. Figure 2 shows a typical pattern of heart rate change and ventilation volume during graded exercise test using treadmill and these findings indicate the correlation between the two values. Figure 3 shows the difference of heart rate-ventilation volume relationships among the subjects.

According to these findings, heart rate at resting condition (base HR), difference between heart rate in each graded exercise and base HR (Δ HR), Δ HR/base HR, age, height, weight, BMI (body mass index) were selected as initial explanatory variables for multiple regression equation to predict the ventilation volume.

Statistical processing in preparing to predict pulmonary ventilation from heart rate was performed using the multiple regression analysis program in SAS.

RESULTS AND DISCUSSION

Figure 4 shows the resultant regression equation for predicting the ventilation volume from heart rate. Base HR, Δ HR, height, weight and age remained as significant explanatory variables. Differences between the predicted pulmonary ventilation volume obtained by this equation and observed pulmonary ventilation are shown in Figure 5. The percentage of error at each heart rate level was less than 20%, for 25

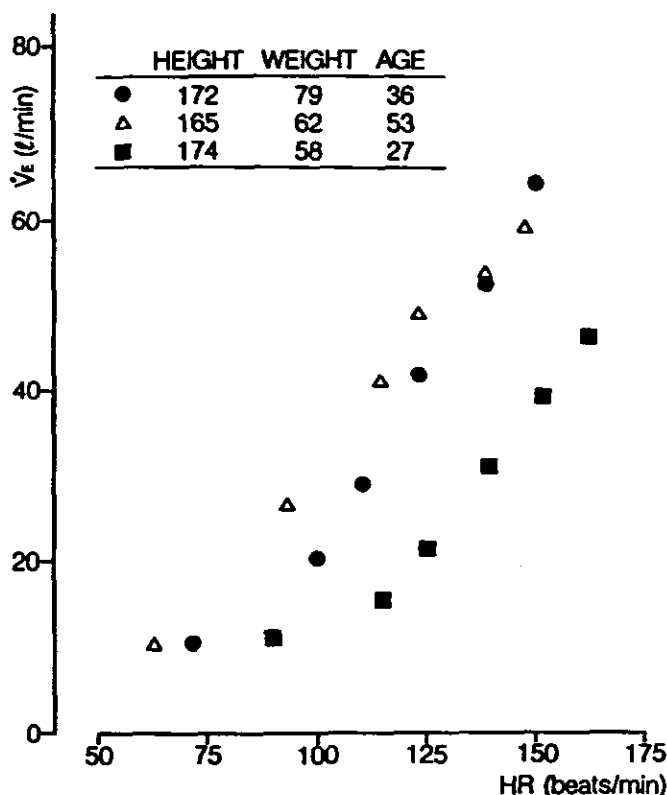

Figure 3. Difference of HR- \dot{V}_E relationships among subjects.

subjects, the differences were less than 10% in each exercise level.

Figure 6 shows a sample of graphic of 1 hour monitoring. The upper photograph abbreviations mean the following, VE: ventilation volume predicted from heart rate (liter/min), BT, ET: body and ambient temperature (centidegree), DC: dust concentration (mg/cubic m), MI: indices of movement. In the lower photograph, Intake means the predicted exposure (mg) that dust concentration was multiplied by predicted ventilation volume.

To assess personal exposure better, measurement of ventilation volume is indispensable.⁵ There are some methods for measuring ventilation volume as following. The first method is direct measurement of the exhalation or inhalation volume and there are several techniques for performing this. However, the subject must wear a mask or mouthpiece. This is uncomfortable, therefore the subject is under an additional amount of determined physical stress, including the increase of respiratory resistance due to wearing the equipment. Because of this, actual ventilation volume measurement may not be possible due to increase. In one indirect measurement method, ventilation volume is calculated from movement of the thorax. With this method, it is easy to see the strong correlation between movement of the chest and the ventilation volume in a state of physical rest.⁶ However, accurate measurement during physical exertion is difficult.

Kucharski confirmed high correlation between heart rate and ventilation volume, and developed a personal dust sampler in which sampling air flow rate varies depending on heart rate. This sampler has been the sole device available for measuring

$$\text{Log } \dot{V}_E = 0.00938 \times X_1 + 0.00422 \times X_2 + 0.00119 \times X_3 + 0.00222 \times X_4 + 0.00335 \times X_5 - 0.0439$$

- X₁: ΔHR
- X₂: HEIGHT
- X₃: WEIGHT
- X₄: AGE
- X₅: base HR

Figure 4. Regression equation calculated from the data of 34 healthy male volunteers.

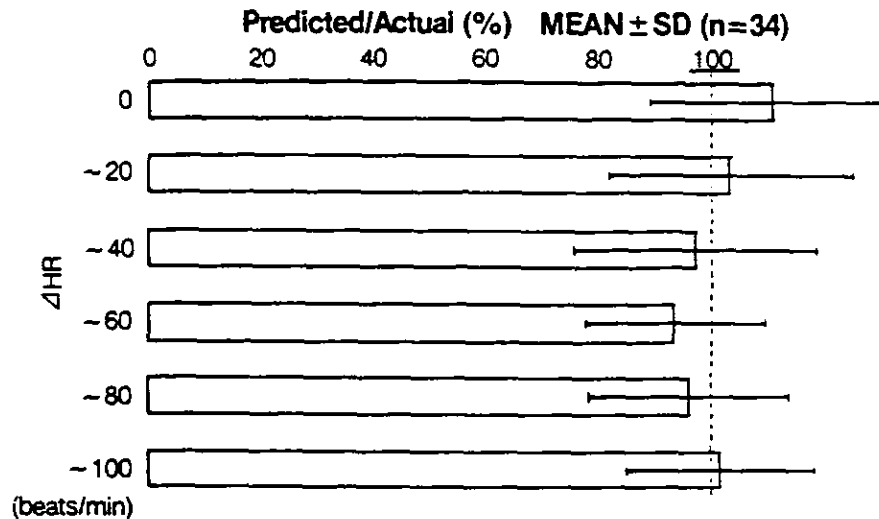

Figure 5. Difference between predicted values and actual values at each heart rate level.

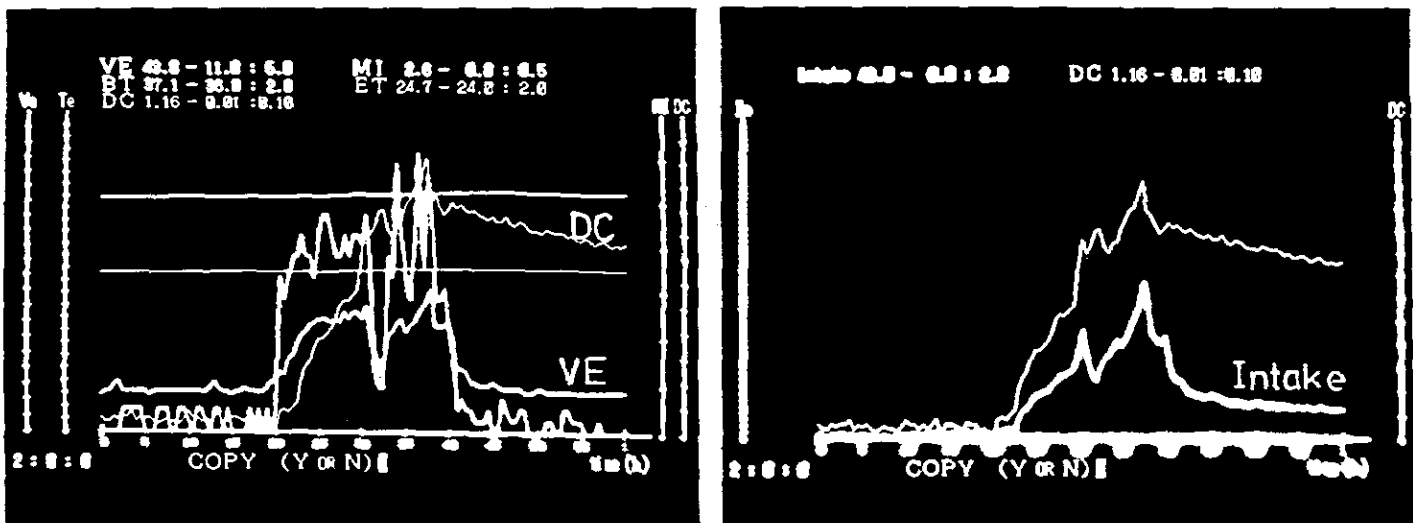

Figure 6. A sample of graphic output on VDU.

exposure in association with pulmonary ventilation.⁷ We also observed the high correlation between the heart rate and the ventilation volume and made a prediction equation. Advantages of our system compared with that of Kucharski are to evaluate the real time dust concentration and ventilation which are useful for assessing the various work conditions.

At actual workplaces, exercise is varied, and there are various factors affecting pulmonary ventilation and heart rate, such as breath-holding and mental stress. However, differences in values due to differences in type of exercise were permissible in view of purpose of our system.⁴

The problems, such as deposition rate of particles depending on their size distribution which is an important factor for assessing actual exposure, and development of more unre-

strictive methods to measure heart rate, still remain unsolved.

CONCLUSION

1. We developed a system that continuously measures airborne dust concentration and heart rate to predict ventilation volume, simultaneously.
2. Ventilation volume can be calculated with the heart rate. The difference between the predicted value and the actual recorded value is negligible for practical use.
3. With this instrument, the actual intake volume could be more accurately evaluated compared with the methods heretofore.
4. Electrodes of heart rate sensor is slightly restrictive for workers. Improvement is necessary in this point.

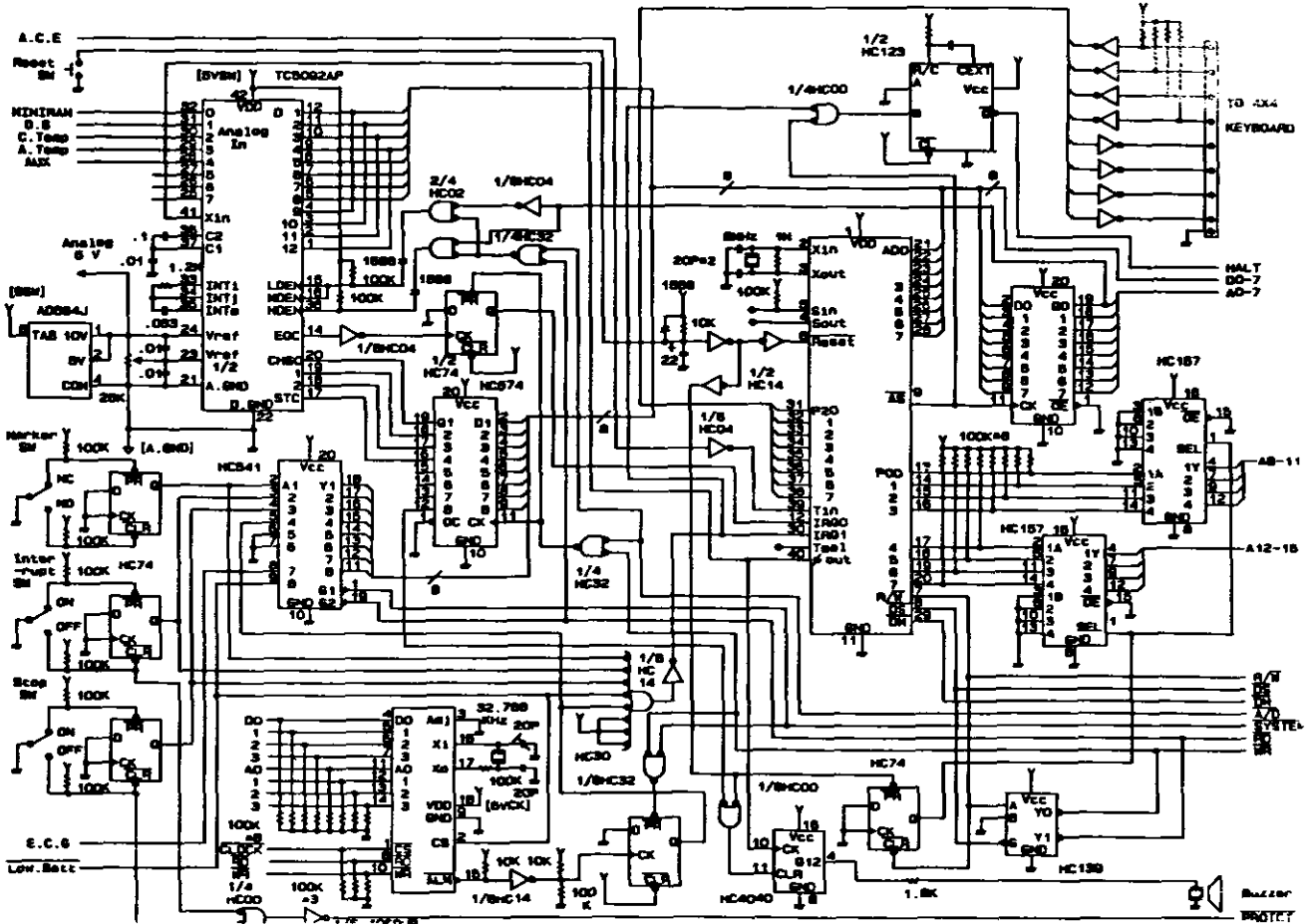

REFERENCES

1. Bjorn, E., Astrand, P.O., et al: Effect of training on circulatory response to exercise. *J. Appl. Physiol.* 24:518-528 (1968).
2. Consolazio, C.F., Nelson, R.A., et al: Body weight, heart rate, and ventilatory volume relationships to oxygen uptakes. *Am. J. Clin. Nutrition* 24:1180-1185 (1971).
3. McMahon, T.A., Brain, J.D., Lemott, S.: *Species differences in aerosol deposition, inhaled particles IV*, part 1, pp. 23-45, Pergamon Press, Oxford (1977).
4. Satoh, T., Higashi, T., Sakurai, H.: Development of a new device for personal exposure measurement considering ventilation volume. *XXII International Congress on Occupational Health, Sydney, Australia (27 September-2 October, 1987).*

5. Sharky, B.J.: Pulse rate and pulmonary ventilation as predictors of human energy cost. *Ergonomics* 9:223-227 (1966).
6. Hill, S.L., Blackburn, J.P., Williams, T.R.: Measurement of respiratory flow by inductance pneumography. *Medical & Biological Engineering & Computing*. 20:517-518 (1982).
7. Kucharski, R.: A personal dust sampler simulating variable human lung function. *Brit. J. Industr. Med.* 37:194-196 (1980).

ACKNOWLEDGEMENT: I wish to express my thanks to Mr. Kouki Isago (RICOH Co.) for his valuable assistance in the design of the DEM-1 and Mr. Yuji Noritake (Ricoh Techno-Research Co.) for his contribution to complete the data processing soft-ware.

CARBORUNDUM PNEUMOCONIOSIS

R. BÉGIN, M.D. • A. Dufresne, Ph.D. • A. Cantin, M.D. • Massé, M.D. •
P. Sébastien, Ph.D. • P. Durand, Ph.D. • G. Perrault, Ph.D.

Université de Sherbrooke, Sherbrooke (QC), Dust Disease Unit, McGill School of Occupational Health, Montréal (QC) and Institut de Recherche en Santé et Sécurité au Travail, Montréal (QC)

INTRODUCTION

Silicon carbide (SiC) also called carborundum is a universally used abrasive produced by the fusion of high-grade silica and finely ground carbon in electric furnace at 2400°C. A recent review of the subject in Parkes textbook⁶ led to the conclusion that there was no evidence that exposure to silicon carbide dust gave rise to a pneumoconiosis.

Nonetheless, pneumoconiosis has been reported in long term workers engaged in the manufacturing of SiC and it was suspected that sick workers had been previously exposed to other dust hazards or to quartz dust in the raw materials of the manufactures. One pathological report raised the possibility of a carborundum pneumoconiosis.⁴

Recent investigations in the Quebec carborundum industry have documented an excess of radiographic abnormalities compatible with pneumoconiosis, particularly in older workers of the industry.⁷ In view of these findings, collaboration with the industry was established and a thorough multidisciplinary investigation was initiated.

Pathological studies of available lung tissue from long term workers of the SiC industry were analyzed in detail.⁵ Recent chest radiographs of 1984 and 1979 of some 128 workers were reviewed.³ Evaluation of occupational exposures in the industry was conducted and reported in detail.^{1,2} A review of the occupational hygiene led to the preparation and characterization of reference samples of respirable particles collected in the SiC production industry for use in this experimental research.

The objectives of this study were to evaluate the *in vivo* lung biologic activity of the mineral dusts found in the carborundum manufacturing industry, to identify the offending dust in order to establish appropriate control of dust level in the workplace.

MATERIALS AND METHODS

Experimental Design

Seventy-two sheep were used in this study. The flock was divided into 9 groups of 8 sheep. Following pre-exposure (control) studies, the sheep tracheal lobe was exposed to:

- 100 ml saline = Sa group (control);
- 100 mg latex beads in 100 ml saline = latex group;
- 100 mg graphite in 100 ml saline = graphite group;

- 100 mg SiC raw particles in 100 ml saline = SiCp group;
- 100 mg SiC ashed particles in 100 ml saline = SiCpa group;
- 100 mg Minusil-5 in 100 ml saline = Si group;
- 100 mg crocidolite fibers in 100 ml saline = Cro group;
- 100 mg SiC raw fibers in 100 ml saline = SiCf group;
- 100 mg SiC ashed fibers in 100 ml saline = SiCfa group.

Exposure to the tracheal lobe was carried out via bronchoscopic infusion of the suspension in the lobe. The animals were studied prior to exposure and post-exposure at month 2, 4, 6, and 8 by BAL and by histopathological methods at month 8.

The Minerals

The materials for exposure were obtained from the following sources: Latex beads from Sigma Chemical Co., St-Louis, MO; these particles are uniform in size with a mean diameter of 1 μ . Minusil-5 from Pennsylvania Glass Co., Pittsburgh, PA; the silica particles are well characterized with 99.9% of diameter < 5 μ , and 95% < 1 μ . Crocidolite fibers from the Union Internationale Contre le Cancer (UICC); these fibers have a known diameter of 0.17 \pm .01 μ with an average length of 3.9 \pm 0.2 μ 95% of fibers with a length < 10 μ , 82% < 5 μ .

All other samples were obtained from the Quebec SiC industry, prepared and characterized. Briefly, these materials were collected from the production sites in the Acheson furnaces of two Quebec SiC plants. The non-fibrous SiC was collected from the center of large lumps of produced materials. The SiC fibers were collected mainly from the outside part of the main cylindrical lump produced by the process. The graphite was extracted from the core of a fired Acheson furnace. The raw particulate and fibrous SiC were, as expected, contaminated with graphite flakes on surface, which at least in theory, could alter biological activity. To eliminate these contaminants, reference samples of fibrous and particulate SiC were ashed. Graphite particles were 98.8% < 5 μ , particulate SiC raw or ashed were 99.5% < 5 μ . For the SiC fibers, seventy percent of fibers were less than 5 μ , with some longer than 20 μ . The fibrous SiC raw or ashed were of an average of 0.27 μ \pm 0.27 diameter with an average length of 6.8 \pm 11.2 μ . These morphometric data were considered in the

selection of the asbestos fiber crocidolite, for comparison in these experiments.

Assessment of Lung Reaction

To evaluate the disease process induced by exposure to these respirable minerals, we looked at lung lavage cellularity and biochemistry as biologic indicators of alveolitis. The severity of lung tissue damage was evaluated at autopsy, 8 months after exposure, by histopathology. To assess interstitial lung matrix changes we looked at the glycosaminoglycan accumulation in BAL fluid. We also measured the production of fibronectin by BAL cells in culture.

Lung lavage fluid was analyzed for the presence of molecules capable of enhancing fibroblast proliferation.

Histopathology

At month 8 of the study, all sheep were sacrificed and the lungs removed from the chest cavity. The tracheal lobe was identified and 9 samples of the lobe of each sheep were obtained each time for microscopic examination.

RESULTS

The Particulates

In comparison to Sa group, all the particulate exposed groups had a slight and transient early increase in cellularity except for the Si group, which had an early 500% increase in cellularity which decreased to 250% at month 4, but remained elevated to the end of experiment. This was largely due to increase in the macrophage population, but increases in lymphocytes and neutrophils were also significant and sustained in the Si group. Similarly, in the biochemical and cell culture analyses, only the Si group had significant increases in BAL lactate dehydrogenase, glycosaminoglycan, and increased production of fibronectin and fibroblast growth activity. The lung morphology of the sheep was normal in groups Sa and latex. The lung tissue of sheep in the graphite group, SiCp and SiCpa groups contained accumulation of particles in alveoli and interstitium without cellular reaction. In the graphite exposed sheep, the morphologic changes are reminiscent of the early simple pneumoconiosis of coal workers.⁶ In the Si exposed sheep, the lung changes are characterized by a diffuse alveolitis with early nodular silicotic lesions as reported in our earlier studies. The pathological scores were 0 ± 0 for Sa group, latex group, graphite group, SiCp group and 2.9 ± 1.0 for the Si group ($p < 0.01$ for Si group vs others).

The Fibers

Briefly, cellularity of BAL was increased in all the fiber groups following exposure with a larger attenuation for the SiCf group. This effect was pancellular and was also seen in the pattern of response of LDH overtime. Fibronectin pro-

duction was significantly increased, again with some attenuation for the SiCf group. Fibroblast growth activity was increased significantly in all fiber groups.

Pathologic analysis of lung tissue in the crocidolite exposed sheep revealed a peribronchiolar fibrosing alveolitis as previously reported in other asbestos exposure. In the fibrous carborundum exposed sheep, we found nodular lesions in the parenchyma which were not located around the bronchioles. These nodules were composed of multinucleated macrophages, monocytes and a few neutrophils and contained several carborundum fibers and "bodies." The intensity and profusion of lesions in the fiber groups were: 1.9 ± 0.25 for Cro group, 1.2 ± 0.21 for the SiCf and 1.6 ± 0.2 for the SiCfa group ($p > 0.05$ between the 3). The slightly lower score ($p > 0.05$) in the SiCf compared to SiCfa could suggest a partial inhibitory effect of the graphite on surface of the SiCf fibers.

DISCUSSION

In recent years, several epidemiological and clinical investigations have suggested that carborundum workers may have a specific occupational lung disease. This experimental study of the airborne dust particles and fibers in the carborundum industry provides significant new information on the pathogenesis of interstitial lung disease in workers of that industry. It documents that of all the non-fibrous particulate minerals encountered on site, only silica appears to be potentially responsible for some of the lung injury. In addition, this study documents clearly that fibrous SiC has significant biologic activity and can initiate a fibrosing lung disease. In SiC manufactures, SiC fiber inhalation can contribute to the genesis of an interstitial lung disease. Therefore, it is appropriate to recommend that surveillance of the work environment in that industry should include an assessment of airborne fiber levels.

REFERENCES

1. Dufresne, A., Lesage, J., Perrault, G.: Evaluation of Occupational Exposure to Mixed Dusts and Polycyclic Aromatic Hydrocarbons in Silicon Carbide Plants. *Am. Ind. Hyg. Assoc. J.* 48:160-166 (1987).
2. Dufresne, A., Perrault, G., Sébastien, P., Adnot, A., Baril, M.: Morphology and Surface Characteristics of Particulates from Silicon Carbide Industries. *Am. Ind. Hyg. Assoc. J.* 49: in press (1988).
3. Durand, P., Bégin, R., Samson, L., Cantin, A., Massé, S., Dufresne, A., Perrault, G., Laflamme, J.: Silicon Carbide Pneumoconiosis: Current Exposure Levels do not Change the Radiographic Assessment of Disease. Submitted for publication, 1988.
4. Funahashi, A., Schlueter, D.P., Pintar, K., Siegesmund, K.A., Mandel, G.S., Mandel, N.S.: Pneumoconiosis in Workers Exposed to Silicon Carbide. *Am. Rev. Respir. Dis.* 129:635-640 (1984).
5. Massé, S., Bégin, R., Cantin, A.: Pathology of Silicon Carbide Pneumoconiosis. *Modern Pathology* 1:104-108 (1988).
6. Parkes, W.R.: *Occupational Lung Disease*, 2nd Ed. Butterworth, London, U.K. (1982).
7. Peters, J.M., Smith, T.J., Bernstein, L., Wright, W.E., Hammond, S.K.: Pulmonary Effects of Exposures in Silicon Carbide Manufacturing. *Br. J. Ind. Med.* 41:109-115 (1984).

IMAGING THE PNEUMOCONIOSES IN 1988: A MULTIDISCIPLINARY APPROACH

R. BÉGIN, M.D. • S. Massé, M.D. • A. Cantin, M.D. •
G. Bisson, M.D. • D. Bergeron, M.D.

Centre Hospitalier Universitaire, Sherbrooke, Québec, Canada J1H 5N4

INTRODUCTION

In recent years, it has become increasingly clear, on the basis of human and experimental data, that lung fibrosis associated with mineral dust inhalation was the end-stage phenomenon of a long chronic inflammatory process initiated by the retention of biologically active mineral particles in the lung tissue.

The early stages of lung tissue reaction to mineral dust deposition is characterized by an excessive accumulation and activation of macrophages in the peripheral bronchoalveolar tissue. This is well documented both in animal studies⁹ and in humans.^{4,5,16} Asbestos dust inhalation produces the fundamental early lesion of asbestosis the peribronchiolar fibrosing alveolitis; quartz dust inhalation produces the more nodular, often perivascular accumulation of macrophages and lymphocytes in the alveolar spaces of lung tissue.

As these mineral dust diseases progress, they are associated with extension of the process to the adjacent alveolar and interstitial lung tissues which leads to diffuse interstitial lung fibrosis. However, we know now that this process can be limited to its early peribronchiolar reaction and leave the lung tissue nearly intact. This is particularly the case for asbestos-induced lung disease. In silica-induced lung disease,¹¹ after the initial nodular lesion, the process becomes less inflammatory, fibroblasts accumulate in the nodules with excessive deposition of reticulin and collagen in and between the cells in the nodule, and eventually the fibrotic collagenous process aggregates the individual nodules to form masses of fibrotic tissue.

Knowing these fundamental pathological processes, strategies to detect these diseases at an early inflammatory stage have been developed.

MODES OF DETECTION

Rales

The observation of bilateral basilar end-inspiratory in asbestos workers with or without asbestosis suggest that auscultatory rales are found in most workers with asbestosis; their profusion correlates fairly radiographic and functional parameters of severity of asbestosis.³ However, rales are the initial finding of disease in asbestos workers in less than 5% of cases and when present, they likely reflect a fibrotic process already in place. In quartz exposed workers, rales are usually absent and of limited interest in detection of silicosis.

Chest Radiograph

The standard PA high kilovoltage chest radiograph is the definite indicator of the mineral dust pneumoconiosis and its value has been well established for the detection of both asbestosis and silicosis. However, it has been documented that the chest radiograph can be normal in up to 10% of symptomatic patients with proven interstitial lung disease. In asbestosis, we have documented similar findings,³⁻⁵ and in silicosis substantial pathological changes in the lung tissues have been observed in stone cutters with normal chest radiograph.¹¹ Thus, whereas chest radiograph is a useful mode of detection of disease, cannot be considered as a sensitive indicator of early disease.

Computed Tomograph of the Thorax

In asbestos related pleuropulmonary diseases, earlier clinical studies^{13,14} on relatively small populations of patients have found that the CT scan was significantly more sensitive than conventional chest X-rays in the detection of disease. We obtained a CT scan of the thorax in 127 long term asbestos workers who were also evaluated by conventional posteroanterior (PA), lateral and obliques (4-view) X-rays, and clinical and functional evaluations.² Our analysis of the total scores of the pleuropulmonary changes and profusion of parenchymal opacities shows that the three methods can detect about the same total amount of abnormalities in each subset of workers, which is at variance with previous clinical reports.^{13,14} Pleural plaques were scored slightly higher on the four-view films than on the PA film, in agreement with a previous report comparing these methods,^{13,14} but pleural plaques were scored significantly lower on the CT scan, mostly because of the lower yields at the costophrenic angles and diaphragms. The largest discrepancies between the three methods were observed in the evaluation of pleural calcifications. On PA films, calcified pleural plaques were often suspected, but could be confirmed by one of the other methods in only two of nine cases. Of the 27 definite pleural calcifications detected in our 127 asbestos workers, however, 14 were detected only by CT scan and all those detected by the PA and four-view films were also observed on the CT scan. Our data on asbestos workers without sufficient criteria for asbestosis but with rigid P-V curve and increased Ga-67 lung uptake show that the CT scan does not detect significantly more pleuropulmonary abnormalities than PA films. With both methods, workers with early asbestos alveolitis could not be separated from those without asbestos alveolitis or asbestosis.

In 58 silica-exposed workers, we have also used computed tomography of the thorax.⁷ On the basis of chest radiograph, 6 were without silicosis, 30 had simple silicosis without coalescence or large opacity, 13 had silicosis with coalescence and 9 had silicosis with large opacity. In the presence of simple silicosis without coalescence or large opacity on plain chest film, CT scanning of the thorax revealed conglomerations in 10/30 cases, 70% of which could not be seen with the addition of lateral and oblique chest films. This additional information on the presence of conglomeration is particularly important as it identifies the presence of a complicated disease which could be either early coalescence of silicotic nodules, tuberculosis or other lung processes such as lung tumor. Further investigations documented that of the 10 conglomerations detected by CT scan only, 2 were tuberculous lesions, 1 was a carcinoma and 7 were of silicotic origin. It has been reported in the last year that the use of ultra-thin CT scan cuts (1-2 mm) may improve the imaging of interstitial reticular or nodular lung lesions. However, these clinical observations by others and ourselves have not been scientifically validated.

Gallium-67 Scan

Ga-67 scanning has been used in clinical medicine for over 15 years in the detection of tumors and sites of occult infection, two disease processes associated with chronic inflammation. The mechanisms of localization of the radionuclide in the inflammatory site, however, has been only partially clarified recently. After intravenous injection of the radionuclide, Ga-67 is rapidly bound to serum proteins, transferrin, haptoglobin and albumin, and less than 1% is transferred to the leucocytes. Gallium-67 lung uptake is primarily associated with activated macrophages producing excessive amount of fibronectin⁴ and to correlate with histopathological scores of inflammation in lung tissue and with BAL levels of Ga-67 radioactivity retrieval.⁴

In asbestos workers of the mines and mills of Quebec, we have obtained routinely Ga-67 scans in over 300 workers who can be divided into 4 categories:

- A = workers without asbestosis and normal scan,
- B = workers without asbestosis and abnormal scan,
- C = workers with asbestosis and abnormal scan,
- D = workers with asbestosis and normal scan.

The workers in groups A and B have chest radiograph in the ILO categories 0/1 or 0/0 and they do not have bilateral rales on auscultation. Their lung volumes are within normal prediction but some 66% of the workers in group B have increased rigidity of the lung pressure-volume curve and exercise induced hypoxemia.^{3,11} On lung biopsy, they have a peribronchiolar macrophagic alveolitis. The workers in groups C and D have radiographic changes of category $\geq 1/0$, the majority of them have bilateral rales and a restrictive pattern of lung function. What differentiates groups C and D is that workers with asbestosis in group C have increased Ga-67 lung uptake whereas those in group D have a normal scan. These differences between groups A and B or C and D are not related to pleural disease,¹⁵ but relate best to the rate of fall of vital capacity; the workers with enhanced Ga-67 lung uptake have

increased rates of decline of vital capacity per year.

We have obtained computer-based quantitative analysis of Ga-67 uptake in a group of 46 long term workers exposed to silica dust at work in the granite industry or in foundry and in a group of 13, age, sex and smoking habit matched controls. In the controls, Ga-67 scan index averaged 1.77 ± 0.46 ; in the 11 workers exposed to silica dust without silicosis, the index was 3.05 ± 0.69 . In 12 workers with simple silicosis 3.75 ± 0.70 ; in 8 workers with silicosis and coalescence it was 7.25 ± 2.23 and in 15 workers with large opacities it was 7.97 ± 1.03 . These data therefore confirm the work of Siemsen in documenting that Ga-67 lung uptake is enhanced in silicosis and document that in long term silica-exposed workers with or without simple silicosis, Ga-67 lung uptake is increased at 200% control value and when the disease becomes complicated by coalescence and/or large opacity, the Ga-67 uptake is further enhanced to 400% control value.

Bronchoalveolar Lavage

In the interstitial lung disease which could be related to asbestos exposure, BAL analyses are of interest: 1) to eliminate other etiologies of lung injury, 2) to document asbestos exposure, 3) to support other clinical information, 4) to study the biological mechanisms. Following our initial report of a substantial number of long term workers with abnormal Ga-67 scan in the absence of other criteria for asbestosis,¹ we have investigated several asbestos workers and similar studies were conducted by Dr. Rom at NIH. In these studies, it was documented that macrophages of the bronchoalveolar space of asbestos exposed workers demonstrated marked structural changes, were producing excessive amount of fibronectin, fibroblast growth factor and increase γ -interferon which could participate in the pathogenesis of asbestosis. In our experimental studies in the sheep model, we have fully reported similar evidences of activated macrophages producing excessive amount of fibronectin, fibroblast growth factor and neutrophil chemotactic factors. Thus, these data document that in support of a diagnosis of early asbestosis (asbestos alveolitis), BAL analyses can provide additional information which pertains to several mechanistic features of disease activity.

Among our silica workers presented in the Ga-67 scan section of this paper, we obtained BAL in 17. In the workers without silicosis (group 2), our results demonstrated increases in total cellularity ($\times 2$), macrophage ($\times 2$), lymphocyte ($\times 1.5$), neutrophil ($\times 4$), eosinophil ($\times 2$), albumin ($\times 2.5$) and immunoglobulin IgM ($\times 5$), without increases in fibronectin or procollagen. These data in silica exposed long term workers without overt silicosis are essentially in agreement with the data of Christman et al¹⁰ in documenting the presence of a sub-clinical quartz alveolitis in these workers. In the workers with simple silicosis, cellularity of BAL is further increased, particularly for lymphocytes ($\times 4$ control), neutrophils ($\times 8$ control) but with BAL biochemical results comparable to those of group 2. In the workers with complicated silicosis (coalescence and/or large opacity), cellularity is also increased but, whereas albumin in BAL is now comparable to control, immunoglobulins IgG, IgA, IgM are the

highest, fibronectin and procollagen are highly increased ($P < 0.05$), which would agree with the current concepts of an activated fibrotic process. Of interest, we have also documented that when the disease was radiographically detectable, there was a significant increase in fibroblast growth factor which was observed even in the absence of coalescence and/or conglomeration.⁸

Pulmonary Function Tests

In the evaluation of early disease in asbestos workers, several investigators have suggested that spirometry, diffusion and gas exchange studies could identify workers with asbestosis as well as chest radiograph. Furthermore, it has been documented by Jodoin et al,¹² and confirmed in our own investigations that rigidity of the lung pressure-volume curve could be seen in several workers without radiograph changes.^{3,4} We have further documented that this finding was usually associated with enhanced gallium-67 lung uptake and when a lung biopsy was obtained, it showed the fundamental early macrophagic peribronchiolar alveolitis associated with early asbestosis. Also we found that early peribronchiolar disease did not significantly reduce the spirometric flow rates but caused a slight increase in upstream resistance only at low lung volumes.⁶

In silica-exposed workers, we have also obtained the usual lung function tests as well as pulmonary mechanics. This is the subject of distinct report.

DISCUSSION

Recent researches in the biology of the mineral dust pneumoconioses have substantially increased our understanding of the sequence of events leading to fibrosis of the lung. Fibrosis in the mineral dust pneumoconioses is an end-stage result of a chronic inflammatory process which is continuously activated by the chronic retention of the mineral particles in the lung tissue. In parallel, in-depth clinical investigations of mineral dust exposed workers with or without pneumoconiosis have identified workers without the classical findings of the pneumoconiosis but with significant abnormalities of CT-scan, lung lavage, Ga-67 lung scan and lung pressure-volume curves similar to those of early disease in the animal studies. These abnormalities can detect the early inflammatory lesion of mineral dust pneumoconioses before its fibrotic stage. Newer approaches to prevent fibrosis of the lung tissue are currently under animal investigation in several laboratories.

REFERENCES

- Bégin, R., Cantin, A., Drapeau, G., Lamoureux, G., Boctor, M., Massé, S., Rola-Pleszczynski, M.: Pulmonary Uptake of Gallium-67 in Asbestos Exposed Human and Sheep. *Am. Rev. Respir. Dis.* 127:623-630 (1983).
- Bégin, R., Boctor, M., Bergeron, D., Cantin, A., Berthiaume, Y., Péloquin, S., Bisson, G., Lamoureux, G.: Radiographic Assessment of Pleuro-pulmonary Disease in Asbestos Workers: Postero-anterior, Four View Films and Computed Tomograms of the Thorax. *Brit. J. Indust. Med.* 41:373-383 (1984).
- Bégin, R., Cantin, A., Berthiaume, Y., Boileau, R., Bisson, G., Lamoureux, G., Rola-Pleszczynski, M., Drapeau, G., Massé, S., Boctor, M., Breault, J., Péloquin, S., Dalle, D.: Clinical Features to Stage the Alveolitis in Asbestos Workers. *Am. J. Indust. Med.* 8:521-536 (1985).
- Bégin, R., Bisson, G., Lambert, R., Côté, Y., Fabi, D., Martel, M., Lamoureux, G., Rola-Pleszczynski, M., Boctor, M., Dalle, D., Massé, S.: Gallium-67 Uptake in the Lung of Asbestos Exposed Sheep: Early Association with Enhanced Macrophage-derived Fibronectin Accumulation. *J. Nucl. Med.* 27:538-544 (1986).
- Bégin, R., Martel, M., Desmarais, Y., Drapeau, G., Boileau, R., Rola-Pleszczynski, M., Massé, S.: Fibronectin and Procollagen III Levels in Lung Lavage of Asbestos Exposed Humans and Sheep. *Chest* 89:237-243 (1986).
- Bégin, R., Massé, S., Sébastien, P., Bossé, J., Rola-Pleszczynski, M., Boctor, M., Côté, Y., Fabi, D., Dalle, D.: Asbestos Exposure and Retention as Determinants of Airway Disease and the Asbestos Alveolitis. *Am. Rev. Respir. Dis.* 134:1176-1181 (1986).
- Bégin, R., Bergeron, D., Samson, L., Boctor, M., Cantin, A.: CT Assessment of Silicosis in Exposed Workers. *Am. J. Roent.* 148:509-14 (1987).
- Bégin, R., Cantin, A., Boileau, R., Bisson, G.: Spectrum of the Alveolitis in Quartz-exposed Humans. *Chest* 92:1061-1067 (1987).
- Brody, A.R., Hill, L.H., Adkins, B., O'Connor, R.W.: Chrysotile Asbestos Inhalation in Rats: Deposition Pattern and Reaction of Alveolar Epithelium and Pulmonary Macrophages. *Am. Rev. Respir. Dis.* 123:670-679 (1981).
- Christman, J.W., Emerson, R.J., Graham, W.G.B., Davis, G.S.: Mineral Dust and Cell Recovery from the Bronchoalveolar Lavage of Healthy Vermont Granite Workers. *Am. Rev. Respir. Dis.* 132:393-399 (1985).
- Craighead, J.E., Vallyathan, N.V.: Cryptic Pulmonary Lesions in Workers Occupationally Exposed to Dust Containing Silica. *JAMA* 244:1939-1941 (1980).
- Jodoin, G., Gibbs, G.W., Macklem, P.T., McDonald, J.C., Becklake, M.R.: Early Effects of Asbestos Exposure on Lung Function. *Am. Rev. Respir. Dis.* 104:525-535 (1971).
- Jost, R.G., Sagel, S.S., Stanley, R.J., Levitt, R.G.: Computed Tomography of the Thorax. *Radiology* 126:125-136 (1978).
- Kreel, L.: Computed Tomography of the Lung and Pleura. *Semin. Roentgenol.* 13:213-225 (1978).
- Lambert, R., Bisson, G., Lamoureux, G., Bégin, R.: Gallium-67 Thoracic Scan and Pleural Disease in Asbestos Workers. *J. Nucl. Med.* 26:600-603 (1985).
- Rom, W.N., Bitterman, P.B., Rennard, S.I., Cantin, A., Crystal, R.G.: Characterization of the Lower Respiratory Tract Inflammation of Nonsmoking Individuals with Interstitial Lung Disease Associated with Chronic Inhalation of Inorganic Dusts. *Am. Rev. Respir. Dis.* 136:1429-1434 (1987).

EXPERIENCE WITH THE ILO CLASSIFICATION (1980) IN RELATION TO EXPOSURE TIME IN § COAL MINES IN THE FRG

**W.T. ULMER • U. Bengtsson • H.L. Reischig • B. Speckmann •
H.-J. Vautrin • I. Zimmermann**

Pneumoconiosis Research Institute, Bochum (FRG)

ABSTRACT

2347 coal miners were examined in 4 coal mines. The relation between exposure time and X-ray changes following the ILO-classification 1980 is relatively linear. Therefore, for a single coal miner as for the mean value of a mine, an "ILO-classification-step-time" can be determined. Assessed according to ILO-classification categories, on the X-rays the increase shows the same augmentation after termination after 15 years of exposure time as the group of workers still active. In the ILO-classification-step-time, there are tremendous differences (1:10) between different coal workers as well as between mean values of different mines (1:7). From the ILO-classification-step-time, the useful time interval of X-ray reexaminations of coal workers can be detected, too.

No Paper provided.

LUNG FUNCTION MEASUREMENTS ON COAL MINERS

W.T. ULMER • U. Bengtsson • H.L. Reischig • B. Speckmann • H.-J. Vautrin

Pneumoconiosis Research Institute, Bochum (FRG)

ABSTRACT

We performed measurements of airway resistance, thoracic gas volume and arterial blood gases at the same time as X-ray examination with 2496 coal miners. The reactivity of airways was controlled by metacholine-challenge tests, too.

There are age-dependents in 2 to 6,5% miners with signs of an obstructive airway disease. 9,5% showed a hyperreactivity of airways. The hyperreactivity was not age-dependent. There was no correlation between these lung function disturbances and X-ray changes. For the health situation of miners it is important to find out persons with obstructive airway disease in order to avoid a further deterioration of this affection.

No Paper provided.

VISCERAL PLEURAL THICKENING IN ASBESTOS EXPOSURE: THE OCCURRENCE AND IMPLICATIONS OF THICKENED INTERLOBAR FISSURES

S. DAVID ROCKOFF,* M.D., F.A.C.R. • Arnold Schwartz,* M.D. • William Hix,* M.D. • Prashant Rohatgi,* M.D. • Elliot Kagan,† M.B., BCh, MRCPath • David Kriebel,‡ Sc.D.

*The George Washington University Medical Center (GWUMC), Washington, DC, USA

†Georgetown University Medical School, USA

‡School of Public Health, Harvard Medical School, USA

INTRODUCTION

The interlobar fissures are lined by visceral pleura. We have noticed, radiographically, the frequent occurrence of thickened interlobar fissures in asbestos exposed individuals, even when the lungs have been normal otherwise. Visceral pleural thickening in asbestos exposure has not received much attention in the diagnosis of asbestos-related thoracic disease, having been considered mainly to be an extension of a more diffuse pleural reaction to asbestos dust.¹ However, in the 1980 revision of the I.L.O. classification, provision was made to indicate fissural thickening as being present or absent. We studied the significance of such thickening² and describe the potential practical application of fissural thickening on radiographs as an early sign of asbestos exposure. The peripheral deposition of inhaled asbestos fibers in the lung³⁻⁵ and the fact that visceral pleural thickening is the usual finding histologically in asbestosis,⁶ provides a reasonable expectation for a relationship between asbestos exposure and visceral pleural thickening radiographically.

METHODS

A control group of 100 adult male patients with no known asbestos exposure, with good quality posterior-anterior (PA) and lateral chest radiographs read as "no active disease" and admitted for non-thoracic problems were selected from 257 consecutive admissions, after 157 were excluded for inadequate radiographs and/or radiographic evidence of obvious cardiopulmonary disease. The radiographs were classified as to the presence and degree of fissural thickening. All had otherwise normal appearing lungs.

The study group was comprised of 220 asbestos-exposed workers drawn from 241 consecutively encountered individuals participating in an occupational screening program, with 21 being eliminated for absence of adequate radiographs or the presence of cardiopulmonary disease which could interfere with the interpretation. The number of years since first occupational contact was recorded as a measure of asbestos exposure. The radiographs of the study group subjects were analyzed for the following factors:

1. *Parietal pleural plaque formation* was noted to be pres-

ent, absent or questionable.

2. *Interstitial pulmonary fibrosis* was noted as the presence or absence of accentuation of the nonvascular, fine linear lung markings of the type generally referred to as "small irregular opacities," without an attempt to grade the degree of profusion.
3. *Fissural thickening* was graded as 0 = Normal fissures, being <0.5 mm throughout; +/- = Questionable thickening, with areas of apparent thickening (>0.5 mm), which could represent either localized fissural thickening or superimposed fissures; 1 + = Minimal fissural thickening with definite, localized thickening of >0.5 and <1.0 mm; 2 + = Moderate fissural thickening with definite, diffuse fissural thickening >0.5 and <1.0 mm, involving the equivalent of a large portion of the length of a major or minor fissure, with or without localized plaques; 3 + = Marked fissural thickening was extensive, diffuse involvement of the fissure(s) as evidenced by thickening of virtually all of the major and/or minor fissures and/or thickening predominantly >1.0 mm.

In addition to the control and study groups, a series of individuals with *clinically and/or histologically diagnosed asbestosis* were studied to see whether asbestos-induced fissural thickening occurs in the absence of pulmonary fibrosis and, regardless of the presence of radiographically-evident pulmonary fibrosis, to analyze the plain film and computed tomographic appearances of visceral pleural thickening in interlobar fissures.

STATISTICAL METHODS

Group means were examined with Student's "t" test and the relationship between years since first exposure to asbestos and the occurrence of pleural abnormalities was investigated by fitting logistic models, as described in our earlier paper.² These models corrected for the effect of the person's age on the data.

RESULTS

- A. *Control Group*: Combining fissural thickening of 0 and

+/- degrees as "normal" and 1+ to 3+ as abnormal, 84% had "normal" fissures while 16% had fissural thickening. Of those with fissural thickening, none was marked (i.e., 3+) with an equal distribution between "slight" and "moderate" thickening.

B. *Study Group*: Definite fissural thickening was observed in 54.5% while 45.5% had radiographically "normal" fissures. The relationship between fissural thickening and years from first exposure is shown in Figure 1 where it is seen that the 50% probability of having fissural thickening occurs at 21 years after first exposure. With regard to parietal pleural plaques, 38.2% had definite plaque formation while 61.8% had none. As shown in Figure 2, the 50% probability of having pleural plaques occurs 31 years after first exposure. Both the pleural plaques and the fissural thickening were associated with the length of time since first exposure. These data show not only that fissural thickening occurs some 10 years earlier than pleural plaque formation, but also that it is a more common lesion (i.e., 54.5% vs. 38.2%). However, the two types of pleural changes generally occurred together with 85% of those with parietal pleural plaques also having fissural thickening. Further, it was relatively uncommon to see radiographic evidence of pulmonary fibrosis in the absence of fissural thickening.

C. *Fissural Thickening in Clinical Asbestosis*: In studying our series of asbestosis patients, the radiographic finding of fissural thickening was uniformly found even in the absence of diffuse chest wall pleural thickening. Pulmonary asbestosis was found histologically in the absence of radiographic changes in the lungs. (Figure 3) The uncalcified fissural thickening as seen on plain chest radiographs and on computed tomograms is demonstrated in Figure 4. In one of our cases, the fissure was calcified on CT only.⁷

DISCUSSION AND CONCLUSIONS

The data presented suggest some interesting possibilities with regard to the earlier radiographic diagnosis of pulmonary asbestosis. While the relationship between radiographically visualized fissural thickening and underlying asbestos-induced pulmonary fibrosis has yet to be clarified definitively, the visceral pleura is part of the lung (unlike parietal pleural plaques) and thickening of it has been shown to be related to the concentration of asbestos fibers and bodies.⁸

A few comments are in order about radiographic techniques. The I.L.O. method⁹ uses only the frontal view, on which only the minor fissure of the right lung is routinely visualized. To achieve the results presented in our work, the lateral as well as the frontal view is required in order to visualize the major as well as the minor fissures.

Based upon the observations we have made using frontal (PA) and lateral chest radiographs, we conclude the following:

1. Fissural thickening is common in asbestos exposed individuals (54.5%) although it is not specific, being also

seen in 16.0% of an unexposed control group.

2. Fissural thickening was found to be more common than pleural plaque formation in the asbestos-exposed population (i.e., 54.5% vs. 38.2%).
3. An age adjusted analysis using logistic models showed that fissural thickening occurs, on an average, 10 years earlier after asbestos exposure than does pleural plaque formation (i.e., 21 years vs. 31 years). This means that fissural thickening can serve as an earlier, if not more specific, sign of asbestos-related disease of the thorax.
4. The severity of the fissural thickening, when adjusted for age, increases with length of time since first exposed to asbestos, suggesting its direct relationship to the asbestos exposure.
5. The plain film and computed tomographic appearances of the fissural thickening ranges from isolated visceral pleural plaques to thickening involving entire fissures. Our cases rarely showed any relationship to diffuse, generalized pleural thickening.

There are two potential practical clinical applications of the finding of fissural thickening on radiographs. First, if a person is known to have been exposed to asbestos, it could be a marker of early involvement of the lungs as the result of the exposed and lead to appropriate inquiries. In individuals without known occupational exposure, the finding of unexplained fissural thickening could lead to inquiries which might indicate unusual spousal or environmental contact with asbestos dust, bearing in mind that isolated fissural thickening is a non-specific finding.

REFERENCES

1. McLoud, T.C., Woods, B.O., Carrington, C.B., Epler, G.R., Gaensler, E.A.: Diffuse pleural thickening in an asbestos-exposed population: Prevalence and cause. *Amer. J. Roentgenol.* 144:9-18 (1985).
2. Rockoff, S.D., Kagan, E., Schwartz, A., Kriebel, D., Hix, W., Rohatgi, P.: Visceral pleural thickening in asbestos exposure: The occurrence and implications of thickened interlobar fissures. *J. Thorac. Imag.* 2(4):58-66 (1987).
3. Chung, A., Wright, J.L.: Small airways disease and mineral dust exposure. *Pathol. Ann.* 18:233-252 (1983).
4. Hillerdal, G.: The pathogenesis of pleural plaques and pulmonary asbestosis: Possibilities and impossibilities. *Eur. J. Respir. Dis.* 61:129-138 (1980).
5. *Deposition and clearance of inhaled fibrous minerals in the rat. Studies using radioactive tracer techniques.* Walton WH Ed., pp 259-274. Inhaled Particles IV Proc. Int. Symp., Pergamon Press (1975).
6. Parkes, W.R.: Asbestos-related disorders. *Br. J. Dis. Chest* 67:261-300 (1973).
7. Rockoff, S.D.: CT Demonstration of Interlobar Fissure Calcification Due to Asbestos Exposure. *J. Comput. Assist. Tomogr.* 11 (6):1066-1068 (1987).
8. Warnock, M.L., Kuwahara, T.J., Wolery, G.: The relation of asbestos burden to asbestosis and lung cancer. *Pathol. Ann.* 18:109-146 (1983).
9. *Guidelines for the Use of ILO International Classification of Radiographs of Pneumoconioses.* Occupational Safety and Health Series No. 22 (rev). Geneva, International Labour Office (1980).

Note: Consult with author for figures.

PREVALENCE OF CLINICAL AND RADIOGRAPHIC ABNORMALITIES IN 150 WORKERS EXPOSED TO NON-CALCINED DIATOMACEOUS EARTH IN CENTRAL CALIFORNIA

JOHN HOWARD,* M.D. • B. Dwight Culver,* M.D. • E. Nicholas Sargent,† M.D.

*Southern Occupational Health Center, University of California, Irvine, CA, USA

†Department of Radiology, University of Southern California, Los Angeles, CA, USA

INTRODUCTION

Diatomaceous earth, or diatomite, is a siliceous sedimentary rock composed essentially of the skeletal remains of microscopic single-celled aquatic plants called diatoms. Diatomite is a valuable material with a range of industrial uses. World production is approximately 1.6 million short tons, 45% of which is from the United States. California accounts for more than half of United States production.¹

Diatomite consists primarily of an amorphous silica containing a small percentage of crystalline silica detectable by conventional X-ray diffraction analysis. In the past, diatomite processing included calcination which involves heating the natural diatomite to high temperatures, with or without an alkaline flux, thereby converting the amorphous silica into a fibrogenic crystalline form called cristobalite. The cristobalite content of natural (uncalcined) diatomite is typically less than 1%; that of straight-calcined 10-20%; and that of flux-calcined products 40-60%.

Pneumoconiosis in the diatomite industry has been associated with exposure to calcined products containing cristobalite. In 1953, a United States Public Health Service survey in California demonstrated a 25% prevalence rate of pneumoconiosis among diatomite workers who had been employed for five years or more.²

Since that time, dust control measures have been instituted throughout the diatomite industry and calcination of the natural diatomite has largely been eliminated. Subsequent surveys of the diatomite industry have demonstrated the effectiveness of dust control measures.³

In 1983, a medical surveillance program was begun at Excel Mineral Company, which processes sedimentary rock (characterized as diatomaceous earth) into cat litter absorbent. This report summarizes data on the respiratory symptoms, pulmonary function studies and chest roentgenograms of 150 employees with at least five years of continuous employment at Excel Mineral Company.

SUBJECTS AND METHODS

Study Population

Excel Mineral Company is located in the southern San Joaquin Valley of California and operates two plants at Taft and McKittrick. All current employees at both plants participated

in two medical surveillance surveys done by the Southern Occupational Health Center of the University of California at Irvine. Only employees with at least five years of continuous employment at Excel were included in this report.

Exposure Index

Since only scant personal monitoring data existed on the level of past dust exposure, an exposure index (E.I.) was constructed. First, employee tasks were subdivided into eight categories: (1) mining; (2) milling; (3) packaging; (4) loading dock; (5) delivery; (6) administration; (7) maintenance (inside plant); (8) maintenance (outside plant). Next, these eight job categories were divided into "dusty" 1, 2, 3, 7 and "non-dusty" 4, 5, 6, 8 jobs based on the results of a 1977 personal hygiene study. A dusty job was one in which dust concentrations exceeded 10 mg/cc³. A year spent at a dusty job prior to 1971 (when dust controls were nonexistent) was counted as the equivalent of two dust-years of exposure after 1971. A year spent in a non-dusty job either before or after 1971 did not contribute to the exposure index. Therefore, the E.I. represents the sum of twice a pre-1971 dust-year plus a post-1971 dust-year.

Study Protocol

All current employees participated in medical surveillance surveys done in 1983 and 1988 which included a self-administered health history questionnaire, pulmonary function studies and chest roentgenograms.

The questionnaire elicited information about general medical conditions, specific respiratory system complaints and a complete occupational history. The presence of any one of the following respiratory complaints of cough, wheezing, chest tightness and dyspnea was included in calculation of a total respiratory symptom score. The symptom score ranged from zero (no symptoms present) to four (all four symptoms present).

Spirometric pulmonary function studies were done on site and consisted of a forced vital capacity (FVC) and forced expiratory volume in one second (FEV₁). Spirometry was performed by a NIOSH-trained technologist on an 8-L Collins portable recording spirometer (Warren E. Collins, Braintree, MA) which met NIOSH apparatus criteria. Predicted values were based on Knudson's regression equations.⁴

A single posteroanterior chest roentgenogram was obtained at a nearby physician's office and was interpreted blindly by one of the authors (ENS) according to the ILO Classification of the Pneumoconioses (1980).⁵

Mineral Analysis

Ore from the opencast mine was sent to Clayton Environmental Consultants, Inc. (Southfield, Michigan) for complete mineral content analysis. In addition, dust from several areas in both plants was sent for microscopic particle sizing and mineral analysis including a determination of the proportional content of amorphous and crystalline silica (alpha-quartz, cristobalite and tridymite).

Statistical Analysis

Comparisons between exposure groups were done with Student's two-tailed, chi-square test with and without Yates' continuity correction, and Fisher's exact test.

RESULTS

One hundred fifty (121 males and 29 females) employees present for the 1983 survey who were continuously employed at Excel and present for the 1988 survey were included in this analysis. All subjects were subdivided into three approximately equal categories based on exposure index. Group I (n=82) had an E.I. of zero to eight years, Group II (n=47) had an E.I. of nine to sixteen years, and Group III (n=21) had an E.I. of seventeen or more years. All three groups were comparable ($P > .13$) in sex, age, race, and tobacco smoking history.

Respiratory Symptoms

Respiratory symptom scores increased with exposure index. Group I had a symptom score of 0.8, Group II 1.0 and Group III 1.4. ($P = .048$) In all three Groups, a large proportion of employees complained of wheezing (Group I 26%, Group II 23% and Group III 43%).

Pulmonary Function Tests

Spirometry revealed no obstructive or restrictive defects. Group I had an FVC of 90.6%, and FEV₁ of 78.9% of predicted. Group II had an FVC of 88.0%, and FEV₁ of 79.8% of predicted. Group III had an FVC of 87.9%, and FEV₁ of 79.1% of predicted. There was no significant difference in pulmonary function among the three groups.

Roentgenographic Findings

Eleven employees (7%) had chest roentgenograms which demonstrated parenchymal abnormalities of doubtful significance for pneumoconiosis (profusion score of 0/1 or 1/0). Three employees (2%) had parenchymal abnormalities on chest roentgenograms consistent with pneumoconiosis (profusion score of 1/1 or greater).

Of the three employees with films consistent with pneumoconiosis, one employee's film in Group II had a profusion score of 2/1 and two employees' films in Group III had scores of 2/1 and 2/2. Of note, the three employees whose films demonstrated pneumoconiosis were employed for a total of 9, 20, 21 years, respectively. There were no parenchymal

abnormalities suggestive of irregular or large opacities. In addition, no pleural findings were seen.

Mineral Analysis

Microscopic sizing of dust samples taken from the mill area at both plants revealed a respirable dust content (two microns or less) of 91% of particles. Mineral analysis by X-ray diffraction of both ore and dust samples revealed a mean proportional silica content of 75%, chiefly in the form of amorphous silica (mean 69%) and crystalline silica (mean 6%). Crystalline silica was present in two forms: alpha-quartz (mean 2%) and cristobalite (mean 4%). The mineral content of ore and area dust samples did not differ appreciably.

DISCUSSION

In the past, the prevalence rate of pneumoconiosis in the diatomite industry in California was 25%. Recent surveys of employees in the California diatomite industry have demonstrated a steadily decreasing pneumoconiosis prevalence rate. In fact, a survey in 1984 revealed that only 6 employees out of 473 (2.3%) had films which were classified 1/2 or higher and these employees had been employed in diatomite processing for more than 25 years.³

In our survey, we expected to find an even lower pneumoconiosis prevalence rate than previously published surveys for several reasons. First, calcining at Excel antedated the employment of nearly all members of the current workforce. Second, control measures at Excel have reflected the industry standard for a number of years. Third, we expected that mineral analysis of the natural, uncalcined diatomite would yield a crystalline silica content lower than the 6% mean figure obtained.

In our survey, we found a pneumoconiosis prevalence rate (2%), which was slightly less than previous surveys. Of concern, however, is the fact that employees with positive films had worked in the diatomite industry for much shorter periods of time than those employees with positive films described in other studies.

Mineral analysis of the ore and dust may provide some explanation for the pneumoconiosis prevalence rate found. Since the content of fibrogenic crystalline silica seen in the Excel ore and dust exceeds what is generally found in uncalcined diatomite, employees at Excel may be at greater risk than other employees in the diatomite industry. Further study of this population is planned.

REFERENCES

1. Villota, R., Hawkes, J.G.: Food Applications and the Toxicological and Nutritional Implications of Amorphous Silicon Dioxide. *CRC Crit. Rev. in Food Serv. and Nutrit.* 23:289-321 (1987).
2. Cooper, W.C., Cralley, L.J.: *Pneumoconiosis in Diatomite Mining and Processing*. Public Health Service Publication 601. Washington, D.C. (1958).
3. Cooper, W.C., Sargent, E.N.: A 26-Year Radiographic Follow-Up of Workers in A Diatomite Mine and Mill. *J. Occ. Med.* 26:456-460 (1984).
4. Knudson, R.J., Slatin, R.S., Lebowitz, M.D., Burrows, B.: The Maximal Expiratory Flow-Volume Curve: Normal Standards, Variability and Effects of Age. *Am. Rev. Respir. Dis.* 113:567 (1976).
5. *Guidelines for the Use of ILO International Classification of the Radiographs of Pneumoconioses*. International Labor Office. Geneva (1980).

PROGRAM TO PREVENT ASBESTOS-INDUCED HEALTH HAZARDS IN FINLAND—ASBESTOS PROGRAM IN FINLAND

M.S. Huuskonen • H. Koskinen • H. Vainio • A. Tossavainen • J. Rantanen

Institute of Occupational Health, SF-00250 Helsinki, Finland

The Institute of Occupational Health (IOH) started a program to prevent asbestos-induced hazards in 1987. Special emphasis is placed on primary and secondary prevention of asbestos-related cancers. The program involves the dissemination of information, training, services, and research. The IOH is carrying out the program together with the authorities, industry, unions, the health care system, and insurance companies. The program aims to prevent asbestos-related health hazards (by minimizing exposure to asbestos and by educating workers already exposed), to assess the risks caused by exposure to asbestos, and to improve the diagnosis of asbestos-related diseases in Finland.

EXPOSURE TO ASBESTOS IN FINLAND

The use of asbestos in new production was highest between 1965-1975 (about 12,000 tons annually). Some asbestos products are still produced, but the authorities have stipulated that the manufacture of all asbestos products should cease by 1995. This stipulation, however, does not mean that exposure to asbestos will cease, because asbestos is present in nearly all buildings, ships, etc. built before 1975-1980. More and more old buildings are being renovated. Potential asbestos sources have been assessed only in a few cases. Because of this insufficiently controlled, and on-going, situation, both direct and indirect exposure to asbestos has been more common than is generally realized. Besides occupational environments there are many non-occupational sources of asbestos exposure: refitting schools, hospitals, garrisons, and other public buildings. The goal is to stop using asbestos in new production and to assess the potential asbestos exposure before planning work to renovate old buildings. When asbestos is present, work should always be done so that neither workers nor the environment is exposed.

According to a rough estimate, there are more than 200,000 currently active or retired workers in Finland who have been exposed to over 2 fb/ml for a period of at least two months. Altogether some 50,000 workers (mainly from the construction industry) over 40 years of age have been working in the construction branch for more than 10 years. Thus, on the basis of what is known about the exposure situation in Finland, incidence of asbestos-related diseases will reach its peak during the first decade of the next century.

ASBESTOSIS

A total of about 550 asbestosis cases were diagnosed between 1938-1987. In the last few years, 30-40 cases of asbestosis have been diagnosed annually. Preliminary data from the screening of about 1,000 construction workers suggest that

there are many more undiagnosed asbestosis cases. The mean age of the surveyed groups was 59 years, and the workers had been employed in the construction branch in 1967. One in four screened construction workers had positive parenchymal and/or pleural findings; almost all of them were ignorant of their clinical status. When interviewed, they reported an average of 3.7 years of asbestos exposure. Half of them were retired. The routine health care system had been unable to trace the subjects for further clinical evaluation. It can be inferred that the number of undiagnosed cases of asbestosis is thus equal to or even higher than the number of diagnosed cases.

ASBESTOS AND CANCER

A large proportion of those who develop asbestosis will eventually die of cancer. Of the previously diagnosed Finnish asbestosis patients, about 40% have died of lung cancer, 5-10% of mesothelioma, and 10% of other cancers. At the IOH 130 asbestosis patients have been followed from 1980 to 1985. Eighteen of these 130 patients have contracted lung cancer within this observation period. The rough annual lung cancer incidence is thus 2.3/100.

About 2,000 incident lung cancers are found annually in Finland. Smoking is the most important etiological factor. The etiologic fraction of occupational exposures in the rise of lung cancer varies between 13% and 35%. Asbestos is the most important single occupational cause of lung cancer.^{5,6} In one study it was estimated that 23% of lung cancers could have been prevented by eliminating asbestos exposure.⁶

About 50 pleural mesothelioma cases are diagnosed in Finland each year. The number has tripled in the last 10-15 years. More than 80% of the diagnosed mesothelioma cases have been exposed to asbestos.¹² Only a few peritoneal mesotheliomas have been diagnosed in Finland.

TIME FACTORS IN ASBESTOS-INDUCED CANCER

The studies on asbestos insulation workers suggest that the risk of lung cancer may decline as the length of the observation period increases. In a cohort of 17,800 asbestos insulation workers, Selikoff et al¹¹ found that the relative risk of lung cancer begins to increase ten years from the first such employment, rises to a maximum at 30 to 40 years from the first employment, and then falls. A symmetrical bell-shaped curve with a peak at 35 years from the first employment is a good representation of this relationship.⁸ Asbestos and smoking increases the risk of lung cancer multiplicatively; asbestos increases the relative risk of lung cancer similarly among both smokers and nonsmokers.^{2,3,4}

Peto et al⁹ have shown that, among asbestos-exposed working, the mesothelioma death rates are proportional to the third and fourth power of time from the first exposure. This relationship occurs in a wide range of conditions of exposure and is independent of the worker's age when initially exposed. These findings suggest that asbestos induces mesothelioma by acting in the early stages of carcinogenesis, while asbestos induces lung cancer by acting in the late stages of carcinogenesis. This means that slight exposure at early age could have an important effect in inducing mesothelioma but a negligible effect in inducing lung cancer. In contrast, a high exposure level when middle-aged has an important effect in inducing lung cancer after a relatively short period which is approximately linearly proportional to the dose.

Time considerations may have an important bearing on calculations to determine the amount of asbestos-related malignant disease that can be expected to occur in the future. It may also be important with respect to chemoprevention, especially chemoprevention of lung cancer caused by asbestos.

CANCER CHEMOPREVENTION AMONG ASBESTOS-EXPOSED WORKERS

Vitamin A and beta-carotene (provitamin A) have attracted attention as possible cancer prevention agents.^{1,13} In retrospective epidemiological studies, subjects with low serum concentrations or low estimated dietary intakes of carotenoids, beta-carotene, or retinol have had an increased incidence of developing cancers as compared with matched cohorts having high to normal serum concentrations of these micronutrients.

Vitamin E is able to act as a radical trap in lipid membranes. Some experimental studies have suggested that vitamin E has an inhibitory effect on the development of tumors in experimental animals induced by chemical carcinogens. Relevant epidemiological studies are limited. In two cohort studies, no relationship was found between vitamin E levels and risk of cancer at all sites combined¹³ or for various sites.¹⁰ However, in two other cohorts, significantly lower vitamin E levels were observed among women¹⁴ and men⁷ who subsequently developed cancer than among their controls.

A prospective intervention trial involving administration of beta-carotene and vitamin E to asbestosis patients and subjects heavily exposed to asbestos is presently being planned. The aim is to determine whether daily treatment with beta-carotene (20 mg) and/or vitamin E (50 mg) could result in a lower incidence of (lung) cancer in groups receiving the active treatment as compared to the incidence in the group receiving a placebo.

DIAGNOSTICS AND COMPENSATION

Asbestos-related diseases, including malignancies, have been known for decades. According to the Finnish occupational health legislation, all those with asbestos-induced diseases are eligible for compensation. The information on occupational exposures should therefore be gathered for every mesothelioma and lung cancer patient. In every case the causal importance of asbestos should be evaluated from the medical point of view.

SUMMARY

There is no known safe level of exposure to asbestos at work. Primary prevention is the main goal of the asbestos program of the IOH. Primary prevention carried out today can reduce the disease incidence in future decades. The present disease panorama is the consequence of past exposures (mainly before the 1970s). The peak in asbestos-induced diseases will be reached 15–20 years from now. The annual number of asbestos-related premature deaths is estimated at present to be about 150, which exceeds the annual number of fatal occupational accidents. The number of pleural mesotheliomas has tripled in the last 10–15 years, and is now about 50/year. Only in a few cases of mesothelioma has there been no relevant asbestos exposure. However, clinicians have paid very little attention to exposure to asbestos. Therefore most cases are not registered as occupational diseases, and no claims are filed with insurance companies. Informing and training hospital medical staff is essential to improve the situation. The termination of exposure, antismoking campaigns, improved diagnostics, and careful attention to compensation issues, as well as clarifying the potential for chemoprevention, are the central points of the asbestos program of the IOH.

REFERENCES

1. Committee on Diet, Nutrition and Cancer. Assembly of Life Sciences, National Research Council: Diet, Nutrition and Cancer. National Academy Press, Washington, D.C. (1982).
2. Blot, W.J., Harrington, J.M., Toledo, A., et al.: Lung cancer after employment in shipyards during World War II. *N. Engl. J. Med.* 299:620-624 (1978).
3. Blot, W.J., Morris, L.E., Stroube, R., et al.: Lung and laryngeal cancers in relation to shipyard employment in coastal Virginia. *J.N.C.I.* 65: 571-575 (1980).
4. Hammond, E.C., Selikoff, I.J., Seidman, H.: Asbestos exposure, cigarette smoking and death rates. *Ann. N.Y. Acad. Sci.* 330: 473-490 (1979).
5. Kjuus, H., Skjaerven, R., Langård, S., et al: A case-referent study of lung cancer, occupational exposures and smoking. II. Role of asbestos exposures. *Scand. J. Work Environ. Health* 12:203-209 (1986).
6. Kjuus, H., Langård, S., Skjaerven, R.: A case-referent study of lung cancer, occupational exposures and smoking. III. Etiologic fractions of occupational exposures. *Scand. J. Work Environ. Health* 12:210-215 (1986).
7. Knekt, P., Aromaa, A., Maatela, J., et al.: Serum vitamin E and risk of cancer among Finnish men during the 10 year follow-up. *Am. J. Epid.* 127 (1988) 28-41.
8. Nicholson, W.J., Perkel, G., Selikoff I.J.: Occupational exposure to asbestos: Population at risk and projected mortality, 1980-2030. *Am. J. Ind. Med.* 3:259-311 (1982).
9. Peto, J., Seidman, H., Selikoff, I.J.: Mesothelioma mortality in asbestos workers: Implications for models of carcinogenesis and risk assessment. *Br. J. Cancer* 45:124-135 (1982).
10. Salonen, J.T., Salonen, R., Lappeteläinen R., Maenpää, P.H., Alfian, G., Puska, P.: Risk of cancer in relation to serum concentration of selenium and vitamins A and E: matched case-control analysis of prospective data. *Br. Med. J.* 290 (1985) 417-420.
11. Selikoff, I.J., Hammond, E.C., Seidman, H.: Mortality experience of insulation workers in the United States and Canada 1943-1976. *Ann. N.Y. Acad. Sci.* 330:91-116 (1979).
12. Tossavainen, A., Huuskonen, M.S., Tuomi, T., et al.: Asbestos exposure among Finnish Mesothelioma patients. Presented at *VIIth International Pneumoconioses Conference*. Pittsburgh, August 23-26 (1988).
13. Willett, W.C., Polle, B.F., Underwood, B.A., et al.: Relation of serum vitamins A and E and carotenoids to risk of cancer. *N. Engl. J. Med.* 310:430-434 (1984).
14. Wald, N.J., Boreham, J., Hayward, J.L., Bulbrook, R.D.: Plasma retinol, carotene and vitamin E levels in relation to the future risk of breast cancer. *Br. J. Cancer* 49:321-324 (1984).

STUDY ON HAEMOLYTIC ACTIVITIES OF 10 TYPES OF COAL MINE DUSTS AND THEIR EFFECT FACTORS

XING GUO-CHANG • Lui Tie-Min • Lui Zung-Qi • Zhou Chen

Institute for Occupational Medicine of Ministry of Coal Industry, Beijing, China

INTRODUCTION

Prevalence rate of C. W. P. differs not only in different countries, but also in different coal mines in one country.^{1,2,3} It is so in China. Of course, the difference is due to many factors. Walton, et al⁴ and Reisner, et al⁵ suggested that an unknown factor or factors must play a major role in determining the pneumoconiotic potential of individual dusts.

The haemolytic test is a simple and reliable method for estimating cytotoxicity of silica mineral dusts, which was one of the first systems used for exploring mineral dust cytotoxicity⁶ and later on for cytotoxicity of colliery dust.⁷ Reisner, et al⁵ found that cytotoxicity or coal dust was correlated with the pneumoconiosis risk obtained by epidemiological survey.

In the present study, a vitro haemolytic technique was used to estimate preliminary cytotoxicity of most colliery dusts in China, providing scientific basis for fibrogenic potential of different colliery dusts.

MATERIALS AND METHODS

Preparation of Erythrocyte Suspensions

Healthy male New Zealand rabbits weighing 3 Kg were used for this study (provided by Animals Centre of Academy of Medical Sciences of China). Blood was drawn from the heart, centrifuged at 2000 rpm for 20 min., diluted with sterile physiological saline to make a 2% erythrocyte suspension.

Preparation of Dust Suspensions

10 types of coals used in this study were Fat Coal, Anthracite, Cindery Coal, Meagre Coal, Candle Coal, Weak Caking-Coal, Gas Coal, Lignite, Non-Caking Coal and Lean Coal, provided by Academy of Coal Science of China. The elemental compositions were listed in Table I and Table II. These coal samples were crushed in agate mortar to the particle size distribution less than 5 μ m in dia. accounting for over 95%. Standard quartz dust less than 5 μ m in dia. accounts for over 99%, provided by Academy of Preventive Medical Science of China.

A series of dust samples were dried, sterilized by ultraviolet ray for 30 min., suspended in sterile physiological saline to make the certain concentration and shaken in a high-speed water bath shaker for complete suspension.

Experiment Groups

Coal groups:

10 types of coals were divided into 10 groups. 3 ml erythrocyte suspensions were added into 2 ml of 20 mg/ml to 10 types of coal dust suspensions respectively and then incubated in IDI Water Bath Oscillator (at 37 ± 0.5 temperature, 120 times per min, cyclo-oscillation) for 60 min. The suspensions were centrifuged at 2000 rpm for 60 min and the optical density of the suspensions was measured at 540 nm in a 721 Spectrophotometer.

Quartz control groups:

- Quartz control I: 0.16 mg/ml.
- Quartz control II: 1.25 mg/ml.

Different Concentrations of Coal Groups

A series of Anthracite, Candle Coal and Non-Caking Coal were used as different doses of coal-groups (5, 10, 20 and 40 mg/ml).

Completely Lysed Control and Erythrocyte Fragility Control

3 ml of 2% erythrocyte suspension was centrifuged at 2000 rpm for 20 min and added with 5 ml distilled water to make a complete lysis control. 2 ml of 2% erythrocyte suspension was mixed with 2 ml physiological saline to make an erythrocyte fragility control.

% of haemolysis =

$$\frac{OD_{540} \text{ Test Sample} - OD_{540} \text{ Fragility Control}}{OD_{540} \text{ Fully Lysed Control}} \times 100$$

RESULTS

Comparison of Haemolytic Activities among 10 Types of Coal Dusts

Results of tests done repeatedly 17-20 times are shown in Figure 1 and Table III. It is clearly seen that haemolytic activities of 10 types of coal dusts were different. Degree of haemolysis by Lean Coal and Fat Coal was respectively lowest and highest (range 10-35%). Statistics showed that haemolytic activities of quartz control I and II were significantly higher than those of coal dust-groups and that haemolytic activities of different doses of coal dust-groups were significantly

Table I
Composition of 10 Types of Coals

Types of Coal	Ash (g %)	Volatility	% of Carbon	% of Hydrogen	% of Nitrogen
Anthracite	22.962	3.471	79.944	1.086	0.715
Lean Coal	16.390	16.067	73.293	3.776	1.111
Cindery Coal	24.796	18.623	64.671	3.746	1.012
Gas Coal	11.244	29.332	76.436	4.640	1.323
Candle Coal	11.369	35.763	70.424	4.593	0.723
Lignite	10.042	41.623	63.925	4.020	0.960
Weak Caking Coal	10.340	26.150	71.680	4.380	
Non-Caking Coal	5.940	28.550	63.430	3.430	
Fat Coal	35.780	22.290	57.380	3.700	1.040
Meagre Coal	25.640	14.800	67.200	4.300	1.560

Table II
Composition of Ashes of 10 Types of Coals

Types of Coals	% of SiO ₂	% of Fe ₂ O ₃	% of Al ₂ O ₃	% of CaO	% of MgO	% of SO ₃	% of TiO ₂	% of K ₂ O	% of Na ₂ O	% of P ₂ O ₅
Anthracite	52.67	5.31	30.89	4.13	0.99	1.08	1.13	1.48	0.80	0.47
Lean Coal	46.59	13.83	30.08	3.40	0.67	1.96	1.57	0.76	0.45	0.11
Cindery Coal	46.47	11.33	25.05	7.07	1.59	4.59	1.12	0.89	0.75	0.09
Gas Coal	59.42	5.42	26.75	2.367	0.67	1.61	1.16	1.26	0.33	0.08
Candle Coal	49.08	7.94	32.81	3.49	1.26	1.23	1.44	1.13	0.42	0.34
Lignite	50.42	12.25	22.18	6.68	1.16	3.58	1.06	1.52	0.552	0.18
Weak Caking Coal	52.16	21.47	17.15	2.38	1.09	2.54	1.92	1.06	0.12	
Fat Coal	48.67	4.90	35.04	3.78	1.92	2.90	1.48			
Meagre Coal	49.77	3.34	35.71	3.95	1.54	0.54	1.31			

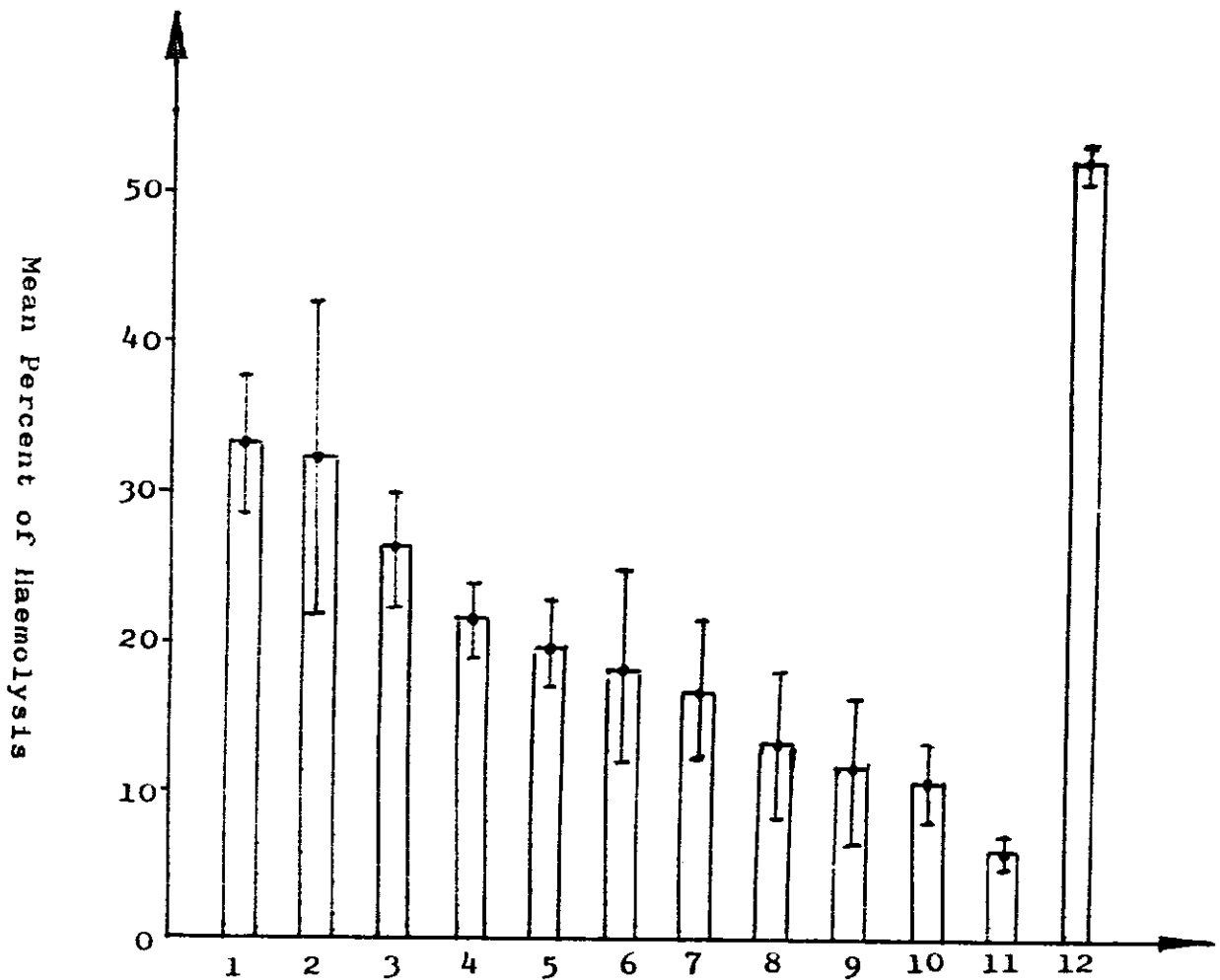

Figure 1. Mean percent of haemolysis of 10 types of coals—(1) Fat Coal, (2) Anthracite, (3) Cindery Coal, (4) Meagre Coal, (5) Candle Coal, (6) Weak Caking Coal, (7) Gas Coal, (8) Lignite, (9) Non-Caking Coal, (10) Lean Coal, (11) Quartz I, (12) Quartz II.

Table III
Endangerment Levels of Coal Dusts

Types of Coals	% Haemolysis	Levels
Fat Coal Anthracite Cindery Coal	33-26	Highest
Meagre Coal Candle Coal Weak Caking-Coal Gas Coal	21-16	High
Lignite Non-Caking Coal Lean Coal	13-10	Low

different ($P < 0.01$, analysis of Variance). Further F-Test showed that except for Anthracite and Candle Coal, Lignite and Lean Coal, haemolytic activities of remaining coal dusts showed statistical significance. Therefore, 10 types of coal dusts were divided into three levels by haemolytic activities, listed in Table III.

Comparison of Haemolytic Activities by the Different Doses of Coal Dusts

Anthracite, Candle Coal and Non-Caking Coal were selected as representatives of three levels of coals as defined above for dose-response test. The results are shown in Figure 2. Haemolytic activities of Anthracite, Candle Coal and Non-Caking Coals were respectively highest, high and low. But at the dust dose less than 10 mg/ml, their haemolytic activities were not significantly different. Starting from the dose of 10 mg/ml, their haemolytic activities increased with increasing dust doses.

Analysis of Effect Factors on Cytotoxicities of Coal Dust

Experimental data were analysed by multiple regression technique using computer to investigate the relationship among % Carbon content (X_1), % Ash content (X_2), % SiO_2 content (X_3) and % AlO_3 content (X_4) in dusts and

haemolytic activities of dusts (Y). The analysis results were as follows.

Relationship between Y and X_1 , $r = 0.89$

Relationship between Y and X_2 , $r = 0.98$

Relationship between Y and X_3 , $r = 0.92$

Relationship between Y and X_4 , $r = 0.94$

Where r is Correlation coefficient.

Maximum amount contributing variance were put into the equation. The result was:

$$Y = -2.382418 + 1.651106X_2 + 2373641X_3$$

Statistics showed that % of Ash content and SiO_2 in dusts made the largest contribution to variance.

DISCUSSION

Many scholars suggested a lot of hypothesis to explain the difference of C.W.P incidence rate in different coal mines with same dust concentration and similar workers' exposure time to dust. Some⁵ thought that it was related to geological age and coal rank. Some² have identified rank and volatility of coal as factors associated with pneumoconiosis. Others¹⁰ thought that it was related to non-coal mineral component and

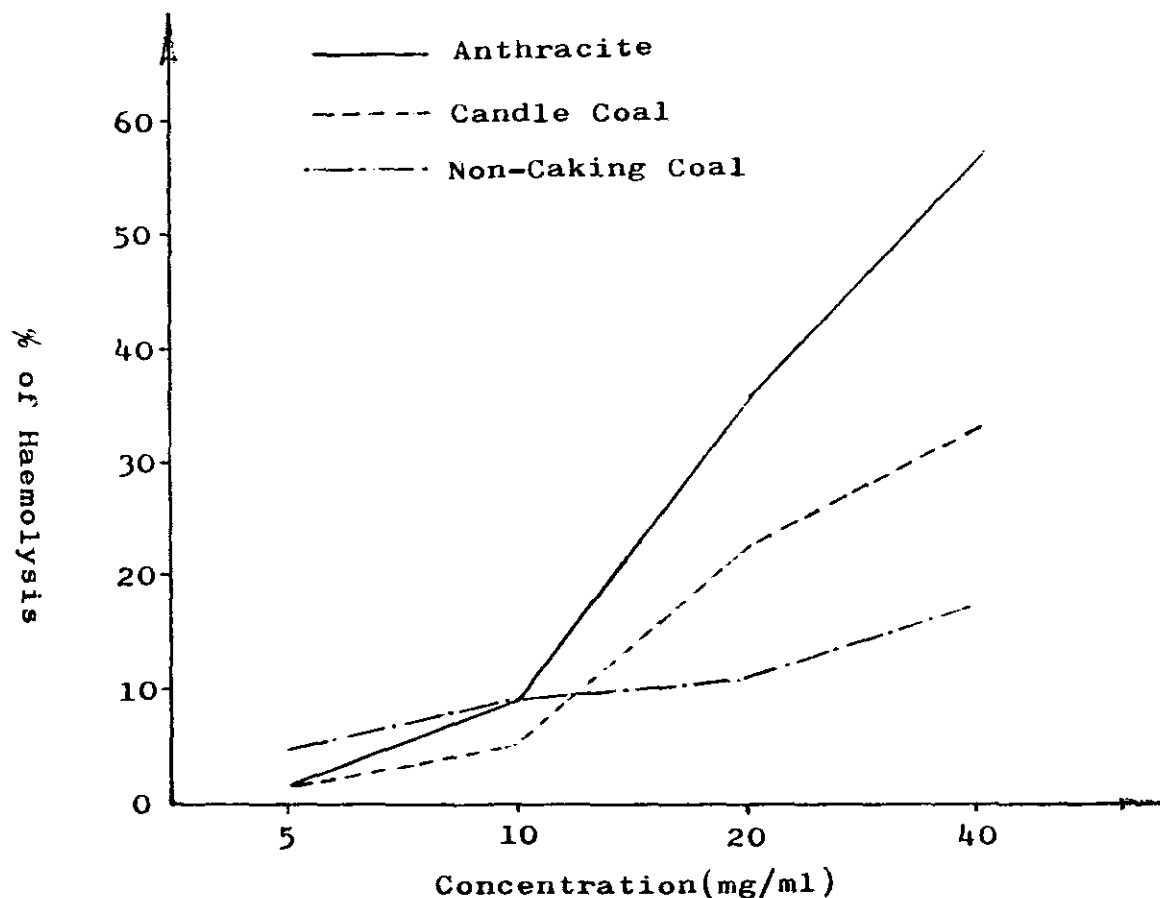

Figure 2. Relation between concentration and percent of haemolysis.

Table IV
Statistical Analysis of Mean Percent of 10 Types of Coals

Types of Coals	Number of Replicates	% of Haemolysis		Variance
		Mean	Standard Error	
Fat Coal	20	33.04	3.95	15.60
Anthracite	17	32.30	12.41	154.01
Cindery Coal	18	26.17	3.23	10.43
Meagre Coal	19	21.10	2.22	4.93
Candle Coal	18	19.43	2.43	5.91
Weak Caking Coal	20	18.48	6.92	47.89
Gas Coal	17	16.39	3.04	9.24
Lignite	19	13.14	4.21	17.72
Non-Caking Coal	19	11.60	4.46	19.89
Lean Coal	18	10.63	2.74	2.51

ash content. Others⁷ thought rank and chemical composition of coal were important. It must be pointed out that unanimity of opinion has not been reached on the role played by SiO₂ in the development of pneumoconiosis. Some scholars^{11,12} think that quartz, even if a small amount of it exists in dust, plays a role in developing pneumoconiosis, but others¹³ don't agree with this opinion. Our experiment showed that from large to small sequence of haemolytic activities of coal dusts were Fat Coal, Anthracite, Cindery Coal, Meagre Coal, Candle Coal, Weak Caking Coal, Gas Coal, Lignite, Non-Caking Coal, and Lean Coal.

The mean haemolytic activities of 10 types of coals were listed in Table IV. It was clearly seen that haemolytic activity of coal was associated with coal type which is related to the geological age. Although times and conditions of coal formation and country rock component have an effect on coal quality, i.e. ash content and component, coal rank and carbon and ash content in 10 types of coals are in above order of haemolytic activity but volatility increased. Therefore, we think that SiO₂ in coal dusts plays an important role in cytotoxicity, which effect of coals themselves is related to period of coal formation. But other factors such as coal rank, volatility carbon content, ash content and SiO₂ content etc. are related to period or coal formation and are affected by condition of coal formation and country rock component.

REFERENCES

1. National Coal Board: *Medical Service and Medical Research Annual Report 1979-1980*. London (1982).
2. Costantino, J.P.: *BCR Pamphlet No. 2. Facts about Coal Worker's Pneumoconiosis*. Bituminous Coal Research, INC, Pittsburgh (1982).
3. Morgan, W.K.C.: *Occupational Lung Diseases*, 2nd Ed., pp. 397, W.B. Saunders Co., Philadelphia (1975).
4. *Inhaled Particles, IV*. pp. 669-690. W.H. Waltin, Ed. Pergamon, Oxford (1977).
5. *IV International Pneumoconiosis Conference*. Relation between Pneumoconiosis and Dust Exposure in West-German Coal Mine. Geneva, ILO (1984).
6. *In Vitro Effect of Mineral Dusts*, p.2. E.G. Beck and J. Bignon, Eds. NATO ASL Services, Springer-Verlag, Berlin (1985).
7. Davis, J.M.C. et al: *Studies on the Cytotoxicity of Coal Dust Samples, Including the Effect of Absorbed Nitros Fumes*. Pathology Branch, Institute of Occupational Medicine, Final Report on CEC Countreat 6244-00/8/105. Edinburgh ().
8. Morgan, W.K.C. et al: The Prevalence of Coal Worker's Pneumoconiosis in U.S. Coal Mines. *Arch. Environ. Health* 27:221-226 (1973).
9. Hurley, J.F. et al: Coal Worker's Simple Pneumoconiosis and Exposure to Dust at 10 British Coal Mines. *Brit. Ind. Med. J.* 39:120-127 (1982).
10. Reiser, M.: *Pneumoconiosis and Dust Exposure Epidemiological Studies in the Ruhr Coal Miner During A Period of 14 Years*. Silikosebericht Nordrhein-Westfalen. 10:209-231 (1973).
11. Spencer, H.: *Pathology of the Lung*, 4th Ed. pp. 443-445, Pergamon Press, Oxford (1985).
12. WHO: *Recommended Health-Based Limits in Occupational Exposure to Selected Mineral Dusts (Silica, Coal)*. WHO Technical Report Series 734. Geneva (1986).

HIGH-SPEED, HIGH-RESOLUTION X-RAY COMPUTED TOMOGRAPHS IN THE DIAGNOSIS OF PNEUMOCONIOSIS

HISAO SHIDA,* M.D. • Keizo Chiyotani,† M.D. • Yutaka Hosoda,‡ M.D.

*Div. of Radiology, Rosai Hospital for Silicosis, Japan

†Div. of Internal Medicine, Rosai Hospital for Silicosis

‡Radiation Effect Foundation

INTRODUCTION

Improvement in CT scanner technology now allows imaging of the lung with excellent anatomic detail demonstrating both normal and abnormal interstitium, patterns of pulmonary abnormalities caused by dust inhalation and morphologic characteristics of localized or generalized parenchymal processes, by circumventing the summation of lung structures in complex anatomic regions such as apices, paratracheal, perihilar, pericardiac, lateral margin of chest walls and diaphragmatic regions. The Fourth generation CT (TOSHIBA TCT 900S) can confirm the presence of pneumoconiotic nodular or interstitial fibrosis associated with areas of lung destruction and disorganization of lung architectures results in a cystic appearance to the lung, bulla, bleb, pulmonary emphysema, broncho-bronchiolectasis, pneumothorax, pleural thickening or plaque and effusion, even if conventional plain chest radiographs cannot visualize these abnormalities.

METHOD

A comparative study between CT and P-A view of computed radiography or conventional chest radiography was made of 108 cases of pneumoconiosis including silicosis, asbestosis, welder's lung, foundry worker's lung and activated carbon pneumoconiosis, the profusion of which ranged from 0/1 to

3/3 according to the ILO 1980 International Classification of Pneumoconiosis.

Special filter function of FC3 and FC4 were provided to visualize detailed images of pulmonary parenchymal or interstitial abnormalities.

RESULTS

The high-speed, high-resolution CT has a high detectability for the abnormalities of pulmonary parenchyma or interstitium and pleura. The presence of emphysematous changes including bulla, bleb, honeycombing, pleural thickening or plaque, septal thickening, subpleural strand, broncho-bronchiolectasis and very small rounded or very fine irregular opacities, can be confirmed, as shown in Table I.

It is considered that the CT will greatly increase the sensitivity of imaging techniques in detecting pneumoconioses and it is a useful procedure in the diagnosis of pulmonary disease at present.

DISCUSSION

In some cases of pneumoconiosis, very small rounded opacities can be difficult to distinguish from vessels seen in the thin cross-section. As general use it is recommended to take image with 5.0 to 10.0 mm in slice thickness.

Table I
 Detectability of CR and CT in 108 Cases of Pneumoconiosis

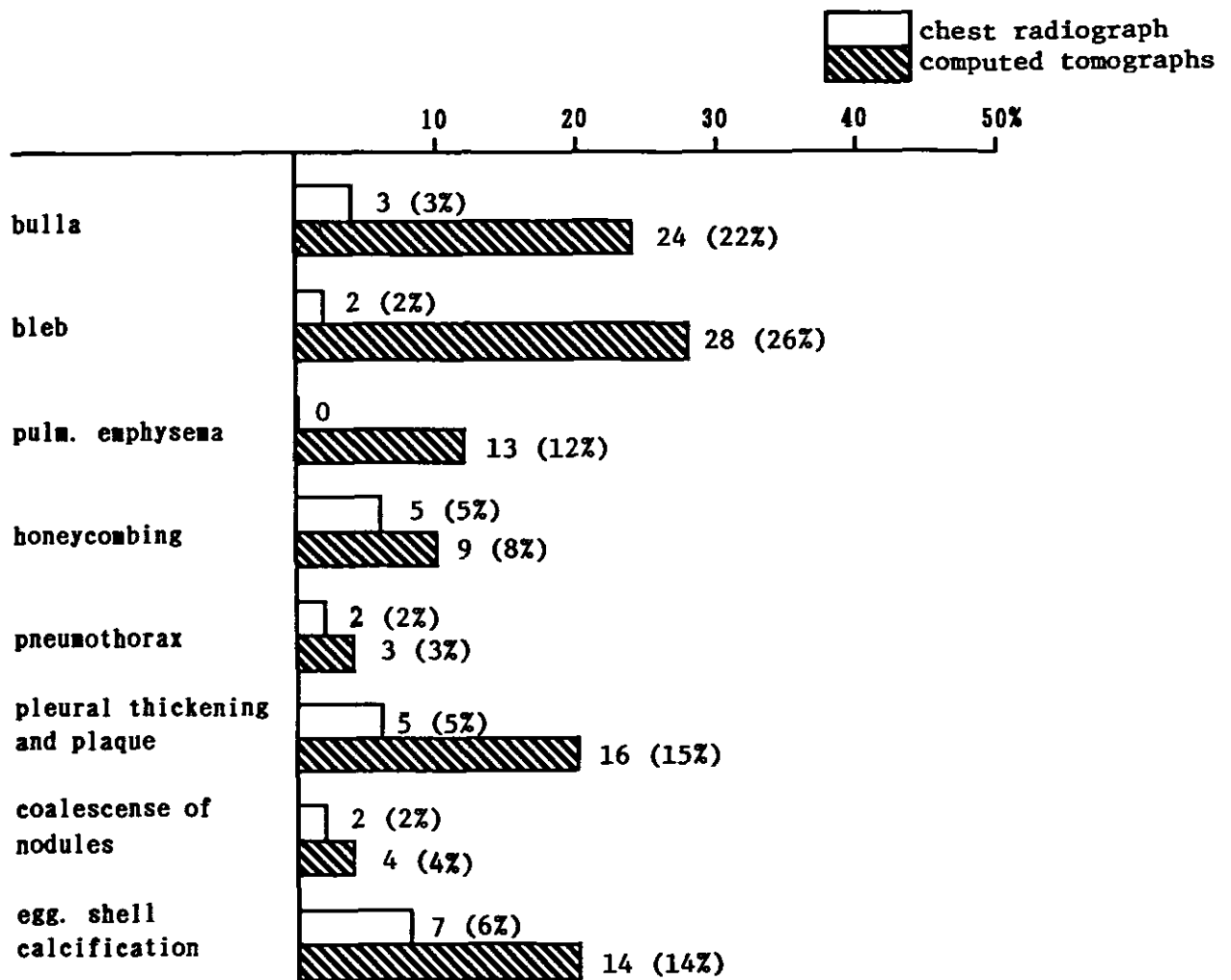

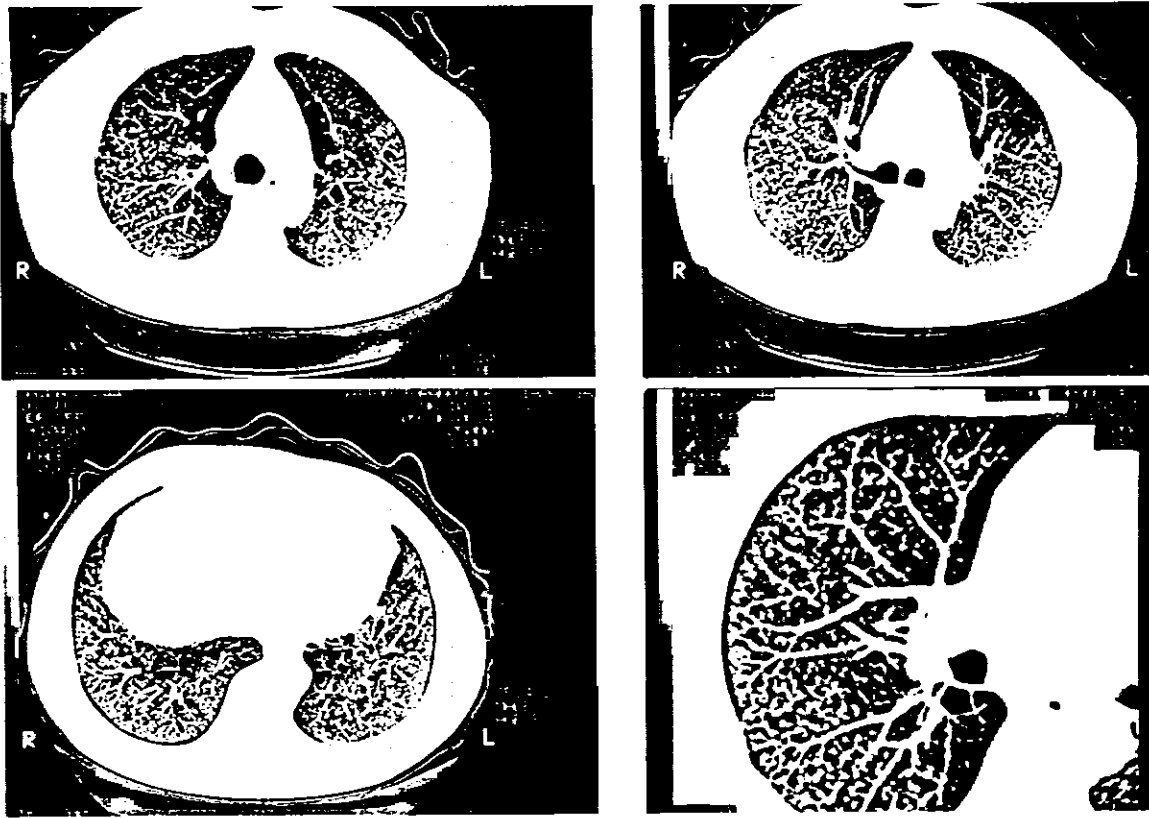

Figure 1. Case 1. 55 year-old, male, silicosis 1/1, P.
CT images demonstrate dense dissemination of fine silicotic nodular high densities throughout lungs. It is noteworthy that these nodules are more clearly and densely distributed than the conventional chest radiograph.

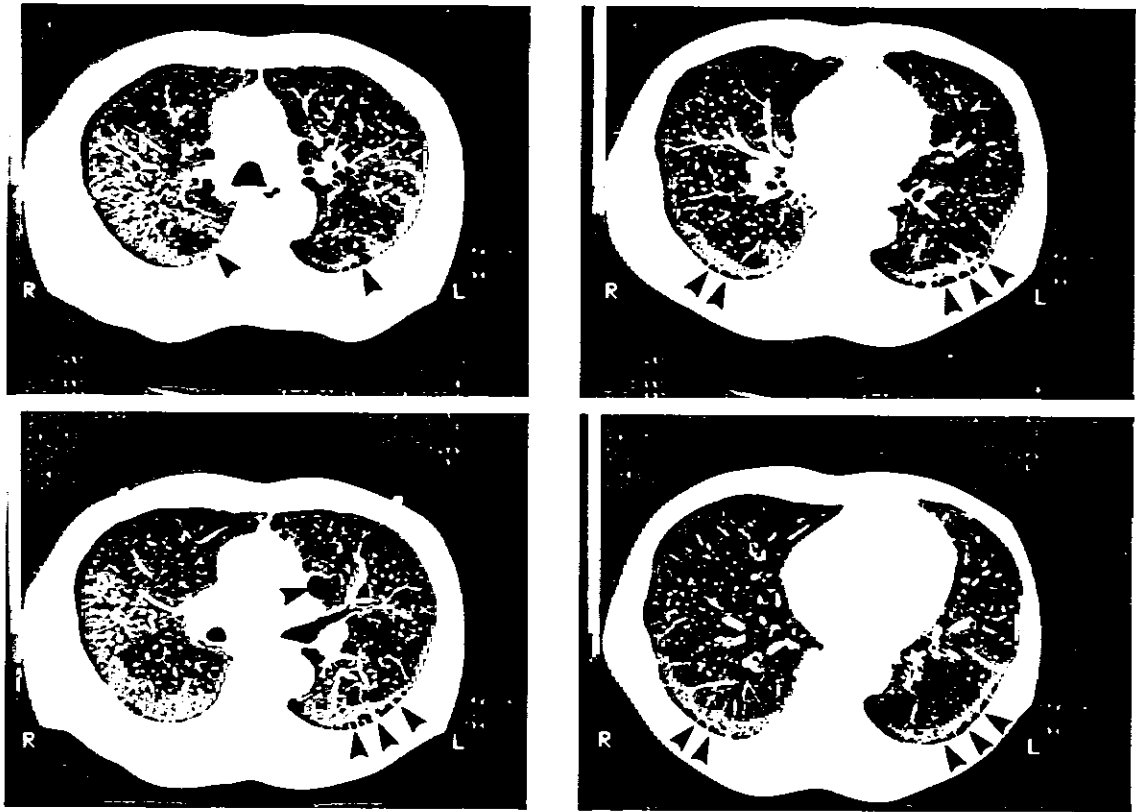

Figure 2. Case 2. 60 year-old, male, silicosis 2/2, q.
CT images reveal dense dissemination of silicotic nodular high densities throughout lungs of which diameter is larger than that of the case 1. Subpleural blebs and bullae are characterized on the CT images. (arrow)



Figure 3. Case 3. 67 year-old, male, silicosis 2/2, q, es, px.
A chest computed radiograph shows dissemination of silicotic nodular high densities throughout lungs and minimal pneumothorax of the left lower lateral margin (white arrow) associated with collapsed lobe. (black arrow)

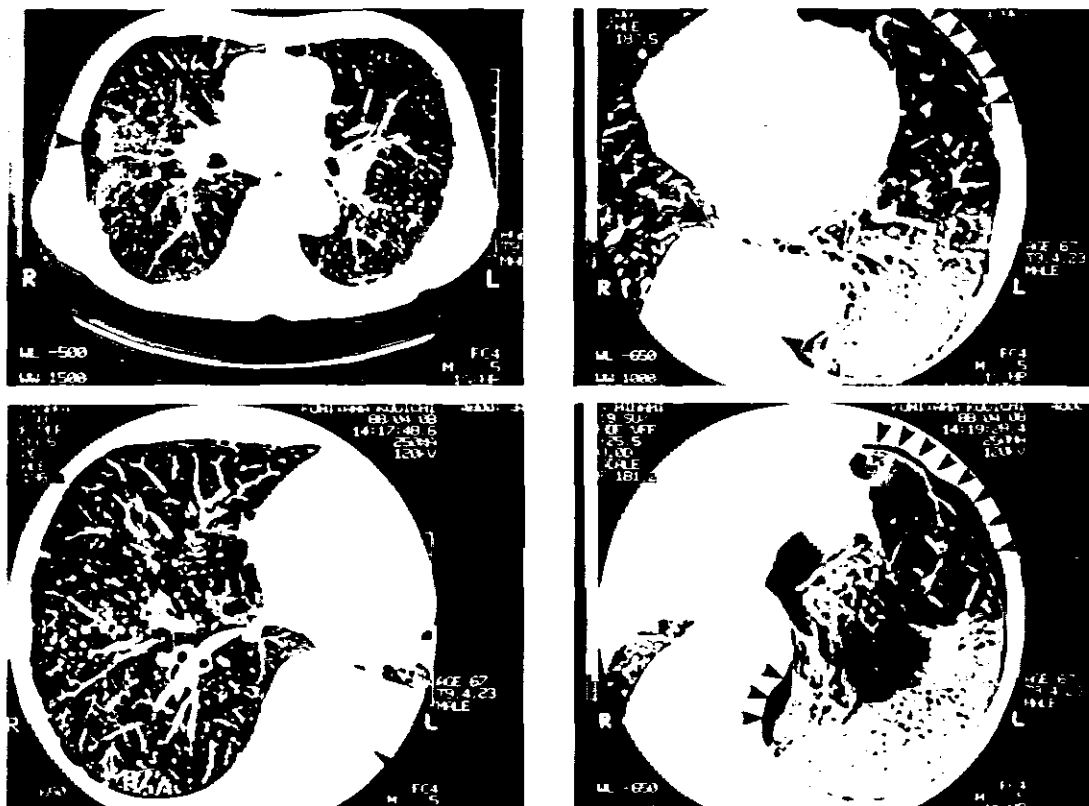

Figure 4. CT images of demonstrate more evident pneumothorax, the collapsed lower lung and bullae. (arrow) These bullae and blebs are not visualized on the conventional chest radiograph. Dissemination of silicotic nodular high densities are also clearly visualized which are located in the middle and posterior lung regions.



Figure 5. Case 4. 59 year-old, welder's lung, 2/2, s.
A chest computed radiograph shows densely distributed fine irregular opacities throughout lungs and the left lung is more hyperlucent than the right.

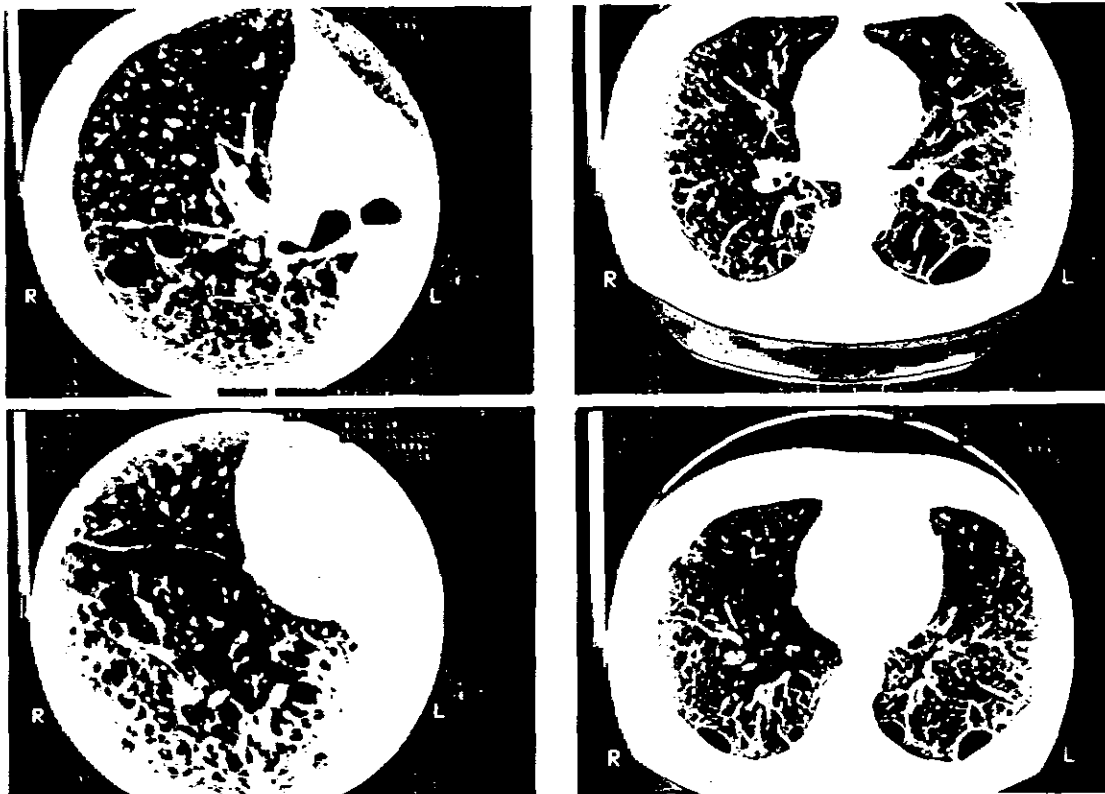

Figure 6. CT images evidently demonstrate strand or streak like interstitial fibrosis, pulmonary emphysema and bullae. On the left super resolution mode images taken by 1.0 mm slice thickness clearly demonstrate impaired lung parenchyma and pulmonary vessels caused by emphysema. The presence of large bullae of the left lung posterior region shows hyperlucency on the chest radiograph.

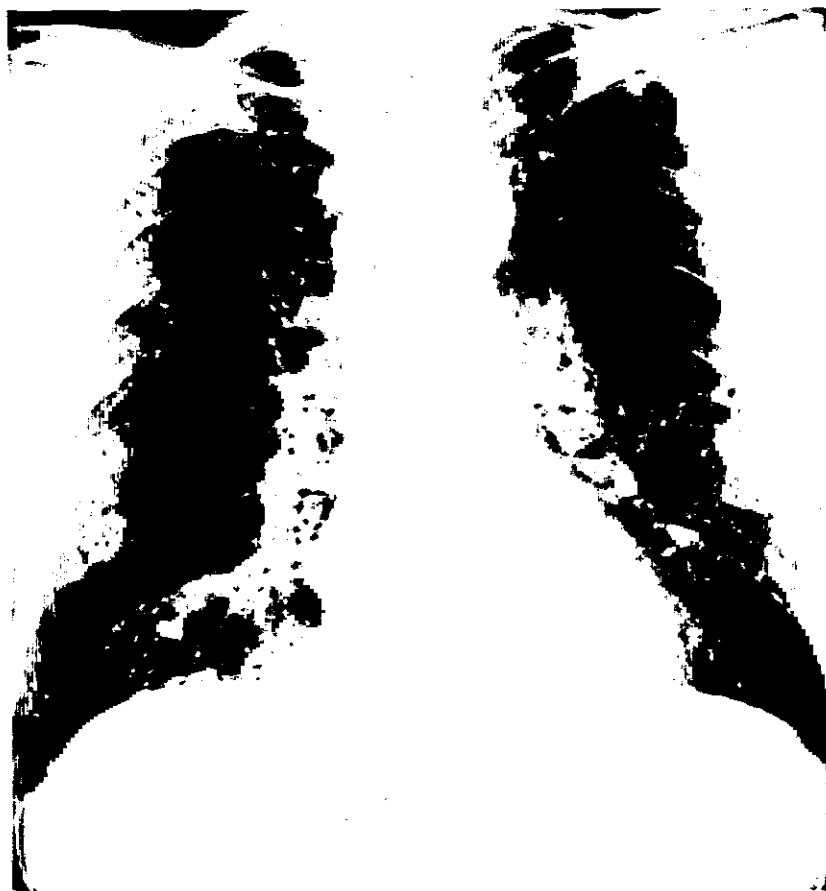

Figure 7. Case 5. 42 year-old, male, foundry worker's lung 2/2, s.
A chest computed radiograph reveals densely distributed fine irregular opacities throughout lungs and on the left upper lung hyperlucency is noted.

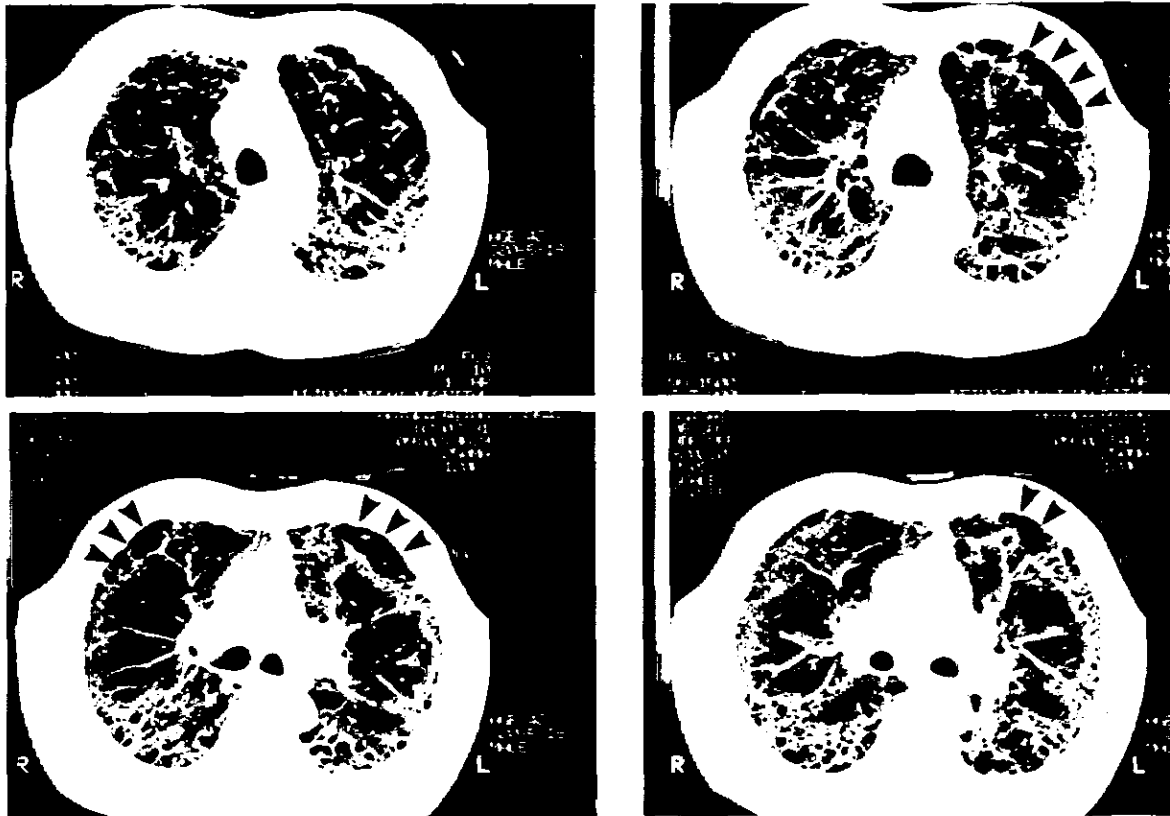

Figure 8. CT images demonstrate strand or streak like interstitial fibrosis associated with pulmonary emphysema, bullae (arrow) and honeycombing.

A CASE CONTROL STUDY OF PNEUMOCONIOTIC COAL MINERS IN BRAZIL*

EDUARDO ALGRANTI, MSc

FUNDACENTRO, São Paulo, SP, Brazil

INTRODUCTION

Coalworkers' pneumoconiosis (CWP) has been known for approximately 150 years. It is one of the respiratory diseases which coal miners are at risk. It is generally accepted that the development of pneumoconiosis depends on a number of variables such as the amount of inhaled dust, the dust composition, the number of years of exposure, the residence time of dust in the lungs and the individual susceptibilities. Except this latter, the other factors are quantifiable, and to date there are reliable studies on the probability of acquiring CWP.⁶

In Brazil, it is known that dust exposure conditions in underground coal mines are critical. Moreover, the dust composition differs from that of the countries where classical studies on CWP were carried out. Brazilian coal has plenty of ashes. Only approximately 60-70% of the mined material is coal. Quartz concentrations are high, often above 10%,⁸ making us assume that CWP in Brazil is distinct from classic CWP. The high quartz content makes dose-response relations (dose = quantity of dust retained in the lungs; response = pneumoconiosis) to be not so strong since the pathogeny of classic CWP and silicosis is different.

With the purpose of identifying discriminant variables between pneumoconiotic and non-pneumoconiotic miners a case control study was carried out with the coal miners—studied in the Projeto Mineração, 1984 (Mining Project—Brazil).

METHODS

A random sample of about 50% of the underground miners in six mines (manual, semimechanized and mechanized) was selected. The chosen miners were engaged in different underground jobs. Out of the 956 miners investigated, 816 had their radiographs read independently by three experienced readers in the ILO Radiological Classification of pneumoconiosis.⁵

One hundred and eight (108) radiographs were considered to be inadequate for reading. From the 708 analysed radiographs, 40 cases of pneumoconiosis (Profusion 1/0 or above) were found, and 80 cases of suspicious radiographs were detected (Profusion 0/1). For analysis the cases were divided in two groups:

Group 1: Single job underground miners (pure exposure)

1A) Profusion 1/0 or above (cases: 12; controls: 33).

1B) Profusion 0/1 or above (cases: 37; controls: 102).

Group 2: Multiple-job underground miners

2A) Profusion 1/0 or above (cases: 32; controls: 91).

2B) Profusion 0/1 or above (cases: 80; controls: 227).

*Supported by grant from the Brazilian Ministry of Labour (SSMT/MTb No. 014/83).

These cases were matched in the ratio of 1:3 or 1:2 based in the following parameters:

1. Years worked underground ± 1
2. Age ± 2
3. Control subjects with profusion 0/0
4. Non-repetitive control subjects
5. Control subjects working in the same mine.

Additionally, for groups 1A and 1B, we selected control subjects performing the same job groups, i.e. supervision, face and maintenance.

These matching criteria excluded 20% to 30% of the cases, due to the lack of controls or only one control.

The analysed variables were cough, phlegm, breathlessness, recent acute respiratory episodes (RARE), FEV₁, FVC and FEV₁/FVC. Cough and/or phlegm were considered positive, when present for more than 3 months. Breathlessness was considered positive, if related to great efforts.

The respiratory functional parameters were calculated by using a dry spirometer (Vitalograph, Vitalograph Limited, Buckingham, UK) and transformed into BTPS. Other data were obtained through a questionnaire on respiratory symptoms, adapted from the questionnaire on Chronic Bronchitis (MRC, UK, 1976).

For calculating the differences concerning cough, phlegm, breathlessness and RARE, we used chi-squared tests from contingency tables 2 \times 2. For FEV₁, FVC, FEV₁/FVC and pack years, we analysed the difference between the means through the Student "t" value. With both tests we rejected the null hypothesis at the 5% level.

RESULTS

The results are shown in Tables I and II. The mean of pack years of the four subgroups of cases and controls did not differ significantly. In subgroup 1A, only FEV₁ was significantly lower in the cases. In subgroup 2A the FVC was significant-

ly lower in the cases and the occurrence of RARE was more frequent in the cases.

The inclusion of miners having radiographs 0/1 or above as cases (subgroups 1B and 2B) made all the differences among the variables of cases and controls non-significant.

Table I
X² Values of Contingency Table of Cases and Controls with Cough, Phlegm, Breathlessness and Recent Acute Respiratory Episodes (RARE)

SUBGROUP	COUGH	PHLEGM	BREATHLESSNESS	RARE
1A	0.02	1.02	1.70	0.50
1B	0.15	0.15	0.01	1.02
2A	0.09	0.69	3.74	4.68*
2B	1.07	1.07	0.47	3.30

* p ≤ 0.05

Table II
Means and Standard Deviations of Lung Function Parameters +

SUBGROUP	FEV ₁	FVC	FEV/FVC
1A	Ca 3.33 ± 0.28	4.21 ± 0.66	0.80 ± 0.12
	Co 3.62 ± 0.57	4.63 ± 0.79	0.79 ± 0.11
1B	Ca 3.69 ± 0.73	4.70 ± 0.78	0.79 ± 0.12
	Co 3.71 ± 0.67	4.67 ± 0.78	0.79 ± 0.11
2A	Ca 3.44 ± 0.59	4.19 ± 0.71	0.82 ± 0.11
	Co 3.72 ± 0.62	4.62 ± 0.67	0.80 ± 0.11
2B	Ca 3.66 ± 0.71	4.59 ± 0.73	0.80 ± 0.11
	Co 3.74 ± 0.66	4.69 ± 0.75	0.81 ± 0.09

* p ≤ 0.05

+ The number of cases and controls are about 20% less than Table I because of rejected spirometries.

Ca = Cases

Co = Controls

DISCUSSION

The studied variables were somewhat discriminating as to differentiate pneumoconiotic from non-pneumoconiotic miners. The findings in the group of pure miners (FEV_1) did not repeat in the multiple job undergroup miners, who in their turn presented FVC and the occurrence of RARE different from that of the control. As approximately 20% of the lung function tests in the original group of 956 miners have been rejected,¹ this may have contributed to the inconsistency of the differences found in the FEV_1 and FVC of subgroups 1A and 2A, as miners with rejected tests (188/956), showed a significantly higher mean of years of exposure than those with accepted tests ($p < 0.01$). The presence of breathlessness was nearly significant in subgroup 2A. Breathlessness, together with the number of years of exposure, FEV_1/FVC , and FEV_1 , were the variables most closely associated with pneumoconiosis, when subgroup 2A was analysed through a probit regression analysis.¹

When the suspected subjects (profusion 0/1) were included as cases there was no difference between cases and controls in both groups. This is an indirect indication that they were probably classified correctly as category 0.

Respiratory symptoms are related to both dust exposure and cigarette smoking.⁷ The average pack years of the analyzed groups did not differ between cases and control subjects, and the effect of dust exposure was also controlled. The low capacity of discrimination presented by the variables cough and phlegm reinforces that pneumoconiosis is independent of the effects of dust on the bronchial tree.⁴

Autopsy studies on coal miners showed that pneumoconiosis

did not correlate with hypertrophy of the bronchial glands, which was related to both cigarette smoking and dust exposure.²

Although case control studies are often inappropriate for conclusive analyses of the cause-effect relationships,³ especially when we are studying high prevalence diseases, these findings concerning pneumoconiosis and respiratory symptoms are in accordance with classic studies on respiratory disease in coal miners.

This group of miners will be followed up in 1989.

REFERENCES

1. Algranti, E.: *Comprometimento Respiratório em Mineiros de Carvão de Subsolo Ativos*. Relatório Interno, FUNDACENTEO São Paulo (1988).
2. Douglas, A.N., Lamb, D., Ruckley, V.A.: Bronchial Gland Dimension in Coal Miners: Influence of Smoking and Dust Exposure. *Thorax* 37:760-764 (1982).
3. Florey, C. de V., Leeder, S.R.: *Methods of Cohort Studies of Chronic Airflow Limitation*. WHO Regional Publications, European Series No. 12 (1982).
4. Hyatt, R.E., Kistin, A.D., Mahan, T.K.: Respiratory Disease in Southern West Virginia Coal Miners. *Am. Rev. Resp. Dis.* 89:387-401 (1964).
5. International Labour Office: *Guidelines for the Use of ILO International Classification of Radiographs of Pneumoconiosis*. Revised Edition 1980. Occupational Safety and Health Series No. 22. Geneva (1980).
6. Jacobsen, M.: *Dust Exposure and Pneumoconiosis at 10 British Coal Mines*, pp. 99-107. With International Pneumoconiosis Conference, Caracas, 1978. Bremerhaven (1985).
7. Morgan, W.K.C.: Industrial Bronchitis. *Br. J. Ind. Med.* 35:285-291 (1978).
8. Valenti, F.I.: *Levantamento das Condições de Segurança e Higiene nas Indústrias Carboníferas, SC*. Relatório Interno, FUNDACENTRO, São Paulo (1986).

SOCIAL AND ECONOMIC BENEFITS OF PREVENTION MEASURES AT EW FLUORSPAR MINE

ZHANG QIFENG

Zhejiang Province Co-operation Group of Prevention and Treatment of Pneumoconiosis
Zhejiang Medical University, Hangzhou, China

ABSTRACT

Since 1962, synthetic dust-lowered measures have brought the significant social and economic benefits to the EW fluorspar mine: (1) The maximum dust concentration (from 1118 mg/m³ to 18.1 mg/m³) and mean dust concentration (from 366 mg/m³ to 1.3 mg/m³) have been reduced by 98.40% and 99.69% respectively. (2) Accumulative incidence rate, morbidity and mortality have been decreased from 24.8%, 85.4% and 5.9% to 0.8%, 0.08% and 0% respectively. The incubation period of the disease was prolonged from 4.3 years to 11.9 years. There has been no patient with silicosis among the miners who have been employed since 1966. (3) If the synthetic measures had not been adopted, there should have been 1709 patients with silicosis and 184 of them should have died of the disease. The measures have actually saved 103.3223 million yuan for the compensation of the loss of the output value, pension etc. After deducting the ventilation and the dustproof, their salaries and other costs used for the patients who have actually suffered from silicosis, 100.7723 million yuan of the economical benefit was gotten. (4) It is an invaluable social benefit that the good health condition of the miners has brought happiness to their families.

No Paper provided.

STUDY ON PROTEIN FACTOR IN ALVEOLAR MACROPHAGE OF EXPERIMENTAL SILICOSIS

ZHANG QIFENG, Ph.D. • Zheng Zhaohe • Yu Yinnian

Member of the Chinese Medical Association, Zhejiang Medical University, Hangzhou Zhejiang, China

The immunological theory of silicosis suggested by Vigliani et al opened a new way for studies on the pathogenesis of silicosis.² Previous researches on biochemical, pathological, and immunological changes in silicosis showed that immunological factors were involved in the producing and developing process of silicosis,³ and that alveolar macrophage (AM) phagocytosis and destruction were important in the pathogenesis of silicosis. In this paper, the research results of a protein factor (PF) in AM of experimental silicosis were reported. It may be of practical significance for early diagnosis and further understanding of the pathogenesis of silicosis.

Conventional methods were used for animal models coping, dust particle preparation, dust instillation, observational indices and pathological, biochemical, immunological examinations.^{4,5,6}

1. *Detection of serum protein factor (SPF) and the relationship between this SPF and the lesion in silicosis.* The anti-silicotic-rat lung rabbit serum (ASLS) and double agar diffusion method were used in the tests. Totally 243 serum samples from 53 silicotic rats and 28 normal rats were examined. The results showed that a SPF existed in the serum of silicotic rats, and between this serum and anti-serum a precipitation line was observed. The positive rate of SPF in silicotic rats was up to 82.8%, while the results were all negative for normal rats.

Different kinds of dust particles were injected into rat lungs. By checking the serum reaction in animals, it could be found that the positive rate of SPF in silicotic rats was closely related to the pathogenetic effect of dust. Higher positive rate was observed for more pathogenetic dust, and vice versa. (see Table I)

SPF positive rate increased with the periods after intratracheal injection of dust. Seven days after injection, SPF was negative; on the fifteenth day the positive rate increased up to 7.7%, and it was as high as 61.5%, 72.7%, 83.0%, and 100%, respectively after 30, 60, 180 and 210 days.

In order to study the dependence of SPF positive rate of silicotic rats on the silicosis lesion, 109 rats were divided into five groups according to wet weight of the lungs. Serum reactions, pathological changes and the amount of lung collagen were compared, and the results showed that SPF positive rate was in consistence with the extent of lesion. (see Table II)

It was also found that SPF positive rate decreased in some degree with the alleviation in silicotic lesion after therapy with PVNO and other drugs in our experiments. (see Table III)

For understanding the SPF level of rats intratracheally injected with quartz dust, 98 serum samples from 22 dusted

Table I
Relationship between SPF Positive Rate and Dust Property

dust	animal numbers	positive numbers	positive rate(%)	mean wet weight of rat lungs (g)
SiO ₂	47	34	82.98	6.3
CaF	4	1	25.00	2.8
SiO ₂ +Na ₂ F	10	2	20.00	4.7
SiO ₂ +Al(OH) ₃	11	4	36.36	4.9

Table II
Relationship between SPF Positive Rate and Silicotic Lesion

Wet weight of rat lungs(g)	animal numbers	positive rate (%)	pathological grade(IV-V%)	content of collagen in whole lung (mg)
3	4	0.0	0.0	63.6
3-4	35	14.3	43.3	130.2
5-6	52	67.3	59.9	184.2
7-8	15	93.3	63.6	247.9
9	5	100.0	70.0	306.3

Table III
Relationship between SPF Positive Rate and Curative Effect of Drugs

groups	animal numbers	positive rate(%) before treatment	positive rate(%) after treatment	wet weight of rat lung (g)	pathological grade
PVNO prevented	5	-	0.0	2.9	0.0
PVNO treated	20	95.0	0.0	4.3	38.7
anti-silica 14	13	76.9	50.0	5.3	70.7
SiO ₂ (control)	15	92.8	77.7	6.3	73.0

rats were examined from 45 to 180 days after chest, peritoneal, subcutaneous, intravenous injection, and SPF were all found negative, while SPF positive rate after intratracheal injection was as high as 72.7% to 83.9%.

2. *Relationship between SPF and AM—Study on the source of SPF.* It is of practical importance to study on the source of SPF for finding a simple, reliable method to diagnose the early silicosis and to define a curative effect index. Hence, we prepared an anti-silicotic-rat AM rabbit serum (ASMS) and investigated its reaction with SPF.

Through light microscope observations of silicosis pathology and tests about PVNO treatment, it was found that the SPF positive rate was closely related to the destruction of dusted AM.

Cytotoxicity test showed that ASLS, ASMS had significant cytotoxic effects on the AM of dusted rats when complements existed in vitro. About 75 to 99 percent of AM was coloured by trypan blue.

Agglutination reaction showed that ASLS, ASMS had

higher agglutination effect on AM of dusted rats and the agglutination titre were 1 640 and 1 1280, respectively.

During agar diffusion precipitation processes, when ASLS and ASMS reacted with the same reactant (serum or lung homogeneity of dusted rats) it was found that two precipitation lines presented pattern of fusion. Precipitation lines formed by the same anti-serum and different reactants fused with each other.

3. *Dynamics of AM numbers in the developing of experimental silicosis.* Using Myrvik's method, AM of rats was collected via bronchus alveolar lavage.¹ By counting the cell numbers, AM numbers of dusted and normal rats were compared and the results showed that the former was much more than the latter. Mean AM numbers of the dusted and normal rats were 169.2 and 38.1 × 10⁶ respectively.

The number of AM at different time after exposure to quartz dust was observed. The results indicated that AM numbers increased with the time. Mean AM numbers were counted to be 57.8, 163.9, 102.9, 175.1, and 347.4 ×

10^6 in 15, 30, 60, 90 and 130 days after exposure of dust. Whereas at each time AM numbers markedly differed from that in normal rats (38.1×10^6).

Wet weight of the lung, lesion extent and lesion hardness were usually used as indices for the degree of silicotic pathological changes. If the silicotic rats were grouped according to wet weight, it could be observed that the increase in AM numbers was in accordance with the increase in wet weight. For instance, AM numbers was 58.6×10^6 for wet weight less than 4 g, the numbers increased to 171.2×10^6 for wet weight of 4–5 g, and it was 239.9×10^6 when the latter was more than 5 g.

If the rats were grouped by AM numbers, it would be found that there was correspondence between AM numbers and extent or hardness of lesion. (Table IV)

DISCUSSION

The serum of experimental silicotic rats may react with ASLS, thus forming a clear precipitation line on the agar base. This indicated that a certain SPF existed in both silicotic rat serum and silicotic rat lung. In the serum of normal rats, due to the lack of the SPF or the small quantity, if there was such PF, it was not detected. SPF positive rate was proportional to the pathogenetic effect of dust, time prolongation after exposure of dust and the extent of silicotic lesion, so this rate might reflect the seriousness of experimental silicotic lesion. SPF positive rate would decrease due to the utilization of effective drugs. In general, the method is characterized by easy operation and can be applied to dynamic observations to rats, and is appropriate to be used as an index of curative effect for experimental silicosis.

Researches on the morphological changes of AM on the tissue section and on the effect of PVNO treatment demonstrated that there was correspondence between SPF positive rate and AM lesion. As the time after exposure to dust increased, AM was gradually destroyed, meantime the lesion progress with the presence of quartz dust. During the process PF was released and accumulated, its content into blood from lung increased.

For this reason SPF positive rate grew.

Control experiments using ASLS and ASMS showed that both anti-serums were cytotoxic to the AM of silicotic rats and caused the AM to agglutinate in vitro. During the agar diffusion tests, the precipitation lines formed between ASLS or ASMS and silicotic rat serum, AM or lung homogeneity fused with each other. The silicotic rat SPF detected by both anti-serums were located in α -globulin position and the precipitation curves tended to fuse. Based on the above mentioned results, we could draw the conclusion that silicotic rat SPF and the destruction of dusted AM were closely related.

The consistent increase of AM reflected the continuous death of macrophages. It is assumed that the following methods can be used for prevention and treatment of silicosis: inhibiting the source of local AM for decrease of phagocytosis; restraining the phagocytotic ability of local AM for reduction of the number of destroyed macrophages; stabilizing the lysosome membrane for protecting AM from quartz dust.

CONCLUSIONS

1. In the serum of silicotic rats a PF was found, the positive rate which is proportional to lesion seriousness, lung fibrogenic extent and the extent of AM destruction. It is also inhibited by some effective drugs.
2. The PF in the serum of silicotic rats was located in α -globulin position and originated from dusted AM.
3. The number of AM in dusted rats was much more than that in normal rats. It increased with time after exposure of dust and was directly proportional to the silicotic lesion.
4. Experimental results showed that AM destruction played an important role in the developing of experimental silicosis. It is believed that silicotic lesion may be detected and evaluated by ASMS, thus a new way to study the early diagnosis, presentation and treatment of experimental silicosis will be provided.

Table IV
Relationship between AM Numbers and Silicotic Lesion

AM numbers ($\times 10^6$ cells)	animal numbers	lung of leaves	lesion extent(%)				lesion hardness(%)			
			0	+	++	+++	0	+	++	+++
100	7	70	30.1	57.1	11.4	1.4	330.0	41.4	24.3	4.3
100–200	6	60	10.0	38.3	36.7	15.0	10.0	41.6	21.7	26.7
200	7	70	2.9	45.7	22.9	28.5	2.8	47.1	45.6	4.5

REFERENCES

1. Myrvik, Q.N., Leake, E.S., Fariss, B.: Studies on Pulmonary Alveolar Macrophages from the Normal Rabbit: A Technique to Procure Them in a High State of Purity. *J. Immunol.* 86:128-132 (1961).
2. Vigliani, E.C., Pernis, B.: Immunological Factors in the Pathogenesis of the Hyaline Tissue of Silicosis. *Brit. J. Ind. Med.* 15:8 (1958).
3. Zhang Qifeng: Immunological Problems in the Pathogenesis of Silicosis. *J. Hyg. Res.* 4:345 (1975) (in Chinese).
4. Zhang Qifeng, et al: Study on a Protein Factor in the Serum of Rats with Experimental Silicosis. In Relation to Occurrence, Development, and Medicine Curative Effects of Silicosis. *J. Zhejiang Med. Univ.* 8:113-115 (1979) (in Chinese).
5. Zhang Qifeng, et al: Study on a Protein Factor in the Serum of Rats with Experimental Silicosis; II Relation to Alveolar Macrophages. *J. Zhejiang Med. Univ.* 8:116-120 (1979) (in Chinese).
6. Zhang Qifeng, et al: Relationship between Alveolar Macrophages and the Development of Silicosis. I Dynamic Change of Numbers of AM in experimental Silicotic Rats. *J. Zhejiang Med. Univ.* 9:121-123 (1980) (in Chinese).

RESPIRABLE DUST WEIGHT CONCENTRATION AND QUARTZ CONCENTRATION IN RESPIRABLE DUST WEIGHT CONCENTRATION IN TAEBACK AND KANGNEUNG COLLIERIES

CHEON YONG-HEE, M.D., D.P.H. • Choi Ho-Chun, Ph.D. • Yoon Young-No, M.S.E. • Kim Hae-Jeong

The Institute for Pneumoconiosis, Korea Labour Welfare Corporation

ABSTRACT

In order to evaluate the working environment of underground coal mines, the respirable dust and the concentration of quartz in respirable dust were measured at the area of Taeback and Kangneung collieries. The quartz concentration was measured by Fourier transform infrared spectrophotometry. The results were compared according to the area and work site (drilling, coal face).

The distribution of data of respirable dust and quartz concentration in respirable dust were well fitted to the log-normal distribution. The geometric mean values of respirable dust were 1.34 mg/m³ (SD, 2.81) on drilling site and 2.55 mg/m³ (SD, 2.61) on coal face at Taeback collieries. At Kangneung collieries, they were 2.44 mg/m³ (SD, 3.63) on drilling site and 4.24 mg/m³ (SD, 2.37) on coal face. The geometric mean values of quartz concentration in respirable dust were 4.24% (SD, 2.59) on drilling and 1.39% (SD, 2.22) on coal face at Taeback collieries. At Kangneung collieries, they were 2.55% (SD, 3.08) on drilling and 1.24% (SD, 2.33) on coal face. There was no significant difference in the mean value of respirable dust between two areas. But the mean concentration of quartz in respirable dust showed significant difference between work site ($p < 0.05$) but no difference between area ($p > 0.05$).

INTRODUCTION

In Korea, raw prevalence rate of occupational disease was 2.2% in 1986. Among them, about 57.3% was pneumoconiosis. Eighty-eight percent of pneumoconiosis was coal worker's pneumoconiosis.⁷ So the environmental management of coal mine is important. Coal vein is narrow, so application of mechanical mining is difficult. Zahorski reported differences of prevalence and incidence rate of C.W.P. according to areas, and similar report was reported by Gilson about prevalence rate.^{12,4} Seaton reported that small concentration of quartz in coal dust is important for pathogenesis of coal workers pneumoconiosis.¹¹

Now there are a few systemically analyzed data about quartz concentration in respirable dust of coal mines in Korea. We planned to evaluate the work environment of coal mines located at Kangneung and Taeback by measurement of respirable dust weight concentration and quartz concentration in respirable dust.

METHOD AND MATERIALS

We selected 70 sampling points at collieries in the Taeback area and 35 sampling points at collieries in the Kangneung area. For the measurement of respirable dust weight concentration, we got 52 samples from Taeback area and 33 samples

from Kangneung area. For the measurement of quartz concentration in respirable dust weight concentration, we got 65 samples from Taeback area and 35 samples from Kangneung area. Casella personal air sampler (England) and MSA Fixt-Flo (Model 1, U.S.A.) were used for sampling of respirable dust. For the analysis of quartz concentration in respirable dust weight concentration, Fourier transform infrared spectrophotometer (Analet Instrument FX-6160, U.S.A.) was used. We got the standard respirable quartz from NBS (National Bureau of Standards, standard reference material number, 1878, particle size $< 5 \mu\text{m}$).

The mean air flow rate of personal dust sampler was 1.80 l/min (SD, 0.13; 1.5-2.0). Sampling was conducted at coal face and drilling site. The zone of sampling point was respirable zone of worker. Fixed site sampling method was used. Three samplers were used at the same time. Sampling was conducted during one shift and the available mean sampling time was 214 (SD, 42; 60-354) minutes. Membrane filter was dried at desiccator for 24 hours and the weight was measured for 5 times. Accuracy of measurement was 0.24%. The pretreatment of sample was conducted by muffle furnace for ashing at 650°C for 2 hours.

For analysis of quartz, we made 7 mm pellet with 80 mg of KBr by the manual of FT-IR of Analet Co. For the compensation of sample loss, correction factor (C.F.) was used as

below.

$$C.F. = \frac{C3}{C1 + C2}$$

C1: the initial weight of KBr (80 mg)
 C2: the weight of standard sample or treated sample
 C3: the weight of pellet

Standard calibration curve was calculated with the standard respirable quartz (NBS, standard reference material number, 1878, particle size < 5 μm) at the wave length of 799 cm⁻¹ (Figure 1).³ The measurable range of quartz was 9.7-196 μg with the sensitivity of 90-112%.²

Percent concentration of quartz was calculated

$$\text{as Quartz (\%)} = \frac{S2}{S1 \times 1000} \times 100$$

S1: the weight of corrected sample (mg)
 S2: the weight of quartz in sample (μg)

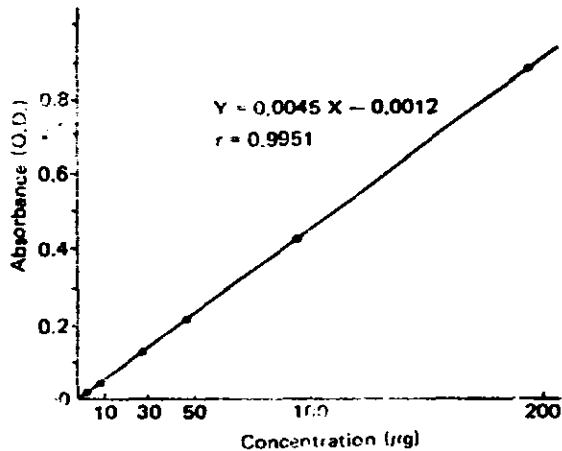

Figure 1. Standard calibration curve for quartz determination by Fourier transform infrared spectrophotometry.

The distribution of respirable dust weight concentration and the quartz concentration in respirable dust weight concentration were tested for normality by chi-square test.

RESULTS

Respirable dust concentration was measured by the time weighted average concentration (mg/m³, TWA) with unit of 0.01 mg. The mean concentrations were calculated by arithmetic and geometric means (Table I). Among all of the respirable dust weight concentrations, 40% of samples were less than 2 mg/m³. The distribution showed skewness to right (Figure 2). When we converted the data into logarithm, histogram showed normal distribution (p > 0.1) (Figure 3). So we used the geometric mean value for t-test. There was no geographical difference between Taeback and Kangneung. But there was significant difference between the drilling and coal face in Taeback (Table II). Quartz concentration was calculated as percent concentration in respirable dust.

Table III shows the quartz concentration in Taeback and Kangneung area. The histogram showed skewness to right

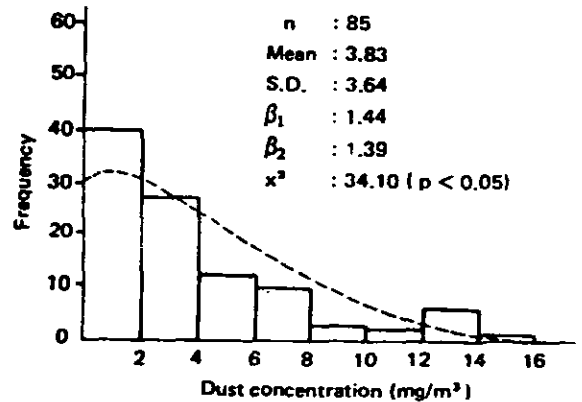

Figure 2. Histogram and expected distribution curve of respirable dust concentrations in Taeback and Kangneung areas.

Table I
 Respirable Dust Weight Concentration in Taeback and Kangneung Areas

Area	Site	Cases	Respirable dust concentration (mg/m ³)					
			Arithmetic		Geometric		Min.	Max.
			Mean	S.D.	Mean	S.D.		
Taeback	Drilling	23	2.00	1.56	1.34	2.81	0.12	5.55
	Coal face	29	3.74	3.14	2.55	2.61	0.30	11.49
Kangneung	Drilling	16	4.55	4.51	2.44	3.63	0.25	12.88
	Coal face	17	5.77	4.53	4.24	2.37	0.50	14.76

S.D.: Standard Deviation, Min: Minimum, Max.: Maximum

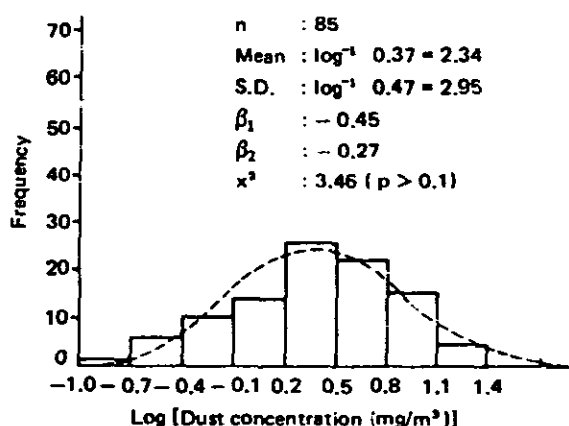

Figure 3. Histogram and expected distribution curve of logarithms of respirable dust concentrations in Taeback and Kangneung areas.

(Figure 4). So, it was converted into logarithmic data (Figure 5) and the logarithmic distribution showed normal distribution ($p > 0.1$). There was no geographical difference of quartz concentration but there was difference between drilling and coal face in both areas ($p < 0.05$) (Table IV).

DISCUSSION

The TLV of coal dust is 2 mg/m^3 in the case of less than 5% of quartz concentration.¹ Table I and Figure 1 reveal that many samples are over the TLV of ACGIH. Zahorski reported that the more narrower of coal seam, the more prevalence rate of coal workers' pneumoconiosis.¹² Saric reported that the dust is more produced from more crumbly coal.¹⁰ The coal seam of South Korea is thin, crumbly anthracite.⁸ So, we think that the higher concentration of respirable dust concentrations are partly due to the character of coal seam in comparison with other countries.^{6,5}

The distribution of respirable coal dust and quartz concen-

Table II
Comparison between Drilling and Coal Face at Taeback and Kangneung Collieries by Logarithms of Respirable Dust Weight Concentration

		Area		t-value
		Taeback	Kangneung	
Site	Drilling	0.13 ± 0.45	0.39 ± 0.56	-1.61
	Coal face	0.41 ± 0.42	0.63 ± 0.38	-1.80
t-value		-2.32*	-1.45	

* $p < 0.05$

Table III
Quartz Concentration in Respirable Dust Weight Concentration

Area	Site	Cases	Quartz concentration (%)					
			Arithmetic		Geometric		Min.	Max.
			Mean	S.D.	Mean	S.D.		
Taeback	Drilling	31	6.18	5.52	4.24	2.59	0.58	24.12
	Coal face	34	1.89	1.54	1.39	2.22	0.40	5.85
Kangneung	Drilling	18	3.54	2.12	2.55	3.08	0.06	7.14
	Coal face	17	2.05	3.37	1.24	2.33	0.46	14.72

S.D.: Standard Deviation, Min: Minimum, Max.: Maximum

tration in respirable coal dust (Figure 3, Figure 5) revealed log normal distribution as Lazarus had reported.⁹

Goldstein reported different respirable dust and quartz concentration in respirable dust weight concentration according to different quality of coal.⁶ Saric also reported that even if the quality was the same, quartz concentration was different according to colliery.¹⁰ He reported that even in the same colliery, there was much variation in quartz concentration. The quality of coal and geologic epoch of Taeback and Kangneung are the same. So, we think that there is no significant regional difference of respirable coal dust and quartz concentration. But we think that the difference of quartz concentration between drilling and coal face is due to rock drilling (Table IV).

SUMMARY

We evaluated the two collieries of Taeback and Kangneung. Respirable dust weight concentrations were measured. Quartz concentration in respirable dust weight concentrations were analyzed by Fourier transform infrared spectrophotometer.

The data of respirable dust and quartz concentration distributed as log normal. In Taeback colliery, geometric mean respirable dust weight concentrations were 1.34 (SD, 2.81; range, 0.12-5.55) mg/m³ at drilling, 2.55 (SD, 2.61; range, 0.30-11.49) mg/m³ at coal face.

In Kangneung colliery, they were 2.44 (SD, 3.63; range, 0.25-12.88) mg/m³ at drilling, 4.24 (SD, 2.37; range, 0.50-14.76) mg/m³ at coal face. As a quartz concentration in

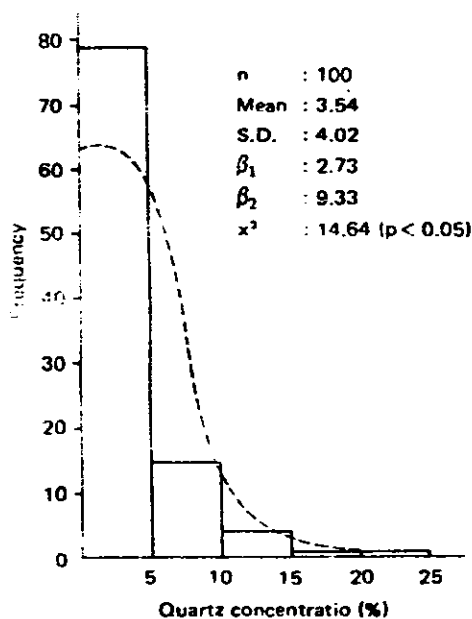

Figure 4. Histogram and expected distribution curve of percent quartz in respirable dust concentrations in Taeback and Kangneung areas.

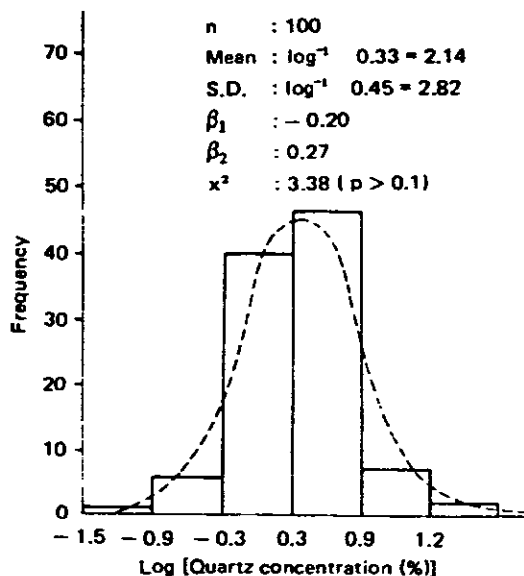

Figure 5. Histogram and expected distribution curve of logarithms of percent quartz in respirable dust in Taeback and Kangneung areas.

Table IV
Comparison between Drilling and Coal Face at Taeback and Kangneung Areas
by Logarithms of Quartz Concentration in Respirable Dust

		Area		t-value
		Taeback	Kangneung	
Site	Drilling	0.63 ± 0.41	0.41 ± 0.49	1.69
	Coal face	0.14 ± 0.35	0.09 ± 0.37	0.48
t-value		5.11*	2.13*	

* p < 0.05

respirable dust weight concentration, geometric mean value of Taeback colliery were 4.24 (SD, 2.59; range 0.58-24.12)% at drilling, 1.39 (SD, 2.22; range, 0.40-5.85)% at coal face.

In Kangneung colliery, they were 2.55 (SD, 3.08; range, 0.06-7.14)% at drilling, 1.24 (SD, 2.33; range 0.46-14.72)% at coal face.

There was no statistically significant difference between two collieries of respirable dust weight concentration and quartz concentration. But there was statistically significant difference in quartz concentration between drilling and coal face at both collieries ($p < 0.05$).

REFERENCES

1. ACGIH: *TLVs Threshold Limit Values and Biological Exposure Indices for 1987-1988*. ACGIH p. 16 Cincinnati (1987).
2. Choi, H.C., Kim, H.J.: Measurement Conditions and Recovery Tests for Free Silica Determination in Dust Samples by Infrared Spectrophotometry. *The Institute for Pneumoconiosis 4-86-2*. Donghae, Korea (1986).
3. Foster, R.D., Walker, R.F.: Quantitative Determination of Crystalline Silica in Respirable Dust Samples by Infrared Spectrometry. *Analyst* 109:1117-1127 (1984).
4. Gilson, J.C.: *A note on Pneumoconiosis Statistics in U.K.* Penarth Glamorgan (1967).
5. Goldberg, S.A., Raymond, L.D., Taylor, C.D.: Bureau of Mines Procedure for Analysis of Respirable Dust from Coal Mines, *Am. Ind. Hyg. Assoc. J.* 34:200-205 (1973).
6. Goldstein, B., Webster, I.: Coal Workers' Pneumoconiosis in South Africa. *Ann. N.Y. Acad. Sci.* 200:306-315 (1972).
7. Korea Industrial Health Corporation: *Annual Report of Health Examination of Workers who are exposed to Hazardous Factors*. Korea Industrial Health Corporation. Seoul, Korea (1986).
8. Korea Mining Promotion Corporation: *Korean Ore Deposit*. 7th Ed. Korea Mining Promotion Corporation. Seoul, Korea (1975).
9. Lazarus, R.: Respirable Dust from Lignite Coal in the Victorian Industry. *Am. Ind. Hyg. Assoc. J.* 44:276-279 (1983).
10. Saric, M.: Prevalence of Coal Workers' Pneumoconiosis in Yugoslavia. *Ann. N.Y. Acad. Sci.* 200:301-305 (1972).
11. Seaton, A., Dick, J.A., Dodgson, J. et al: Quartz and Pneumoconiosis in Coal Miners. *Lancet* 2: 1272 (1981).
12. Zaborski, W.W.: Trends in Coal Workers' Pneumoconiosis in Poland. *Ann. N.Y. Acad. Sci.* 200:292-300 (1972).

COALWORKER'S PNEUMOCONIOSIS AND RESPIRATORY FUNCTION IN CHILEAN MINERS

RODRIGO BENAVIDES-CASTELLON

Medical Director, Compania Siderúrgica de Huachipato, Chile

INTRODUCTION

Coal mining began in Chile in 1882. The coalfields are located in the central part of the country, under the sea, having the collieries an extension of 5 to 25 kilometers from the shore. Their total workforce has been between 5,000 to 10,000 miners that extracts bituminous coal by means of the "long wall" mining method.

In 1979 an Occupational Health Program was established, and this study was developed with the goal of showing the results of the first three years of medical assessment of underground miners. The main objectives were to know the prevalence of Coalworkers Pneumoconiosis (CWP), the respiratory manifestations related to the exposure to coal mine dust, and the probable cause of the respiratory complaints in these coalminers.

MATERIAL AND METHODS

Between 1979 and 1983 a population of 3,754 underground coal miners, actives and retired, were examined at the Occupational Health Department. The mean age of these miners was 45.4 ± 9.4 years, with an average mining working life of 20.6 ± 11 years. The mean weight was 69.4 ± 11.7 kg and their height 163.5 ± 12.4 cm. Most of the retired workmen were referred as claimants for occupational disease benefits, representing a selective group.

The medical assessments include a chest X-ray study consisting in full size postero-anterior radiographs, that were read by a single reader and classified according to ILO/UC International Classification of Radiographs of Pneumoconiosis.⁸ Pulmonary function tests were offered to 1,905 coalminers, the physiological techniques used were those described in previous publications.^{2,18} The spirographic data obtained from the tracings included the forced vital capacity (FVC), forced expiratory volume in one second (FEV₁), and the mean forced expiratory flow 25% to 75% of FVC (FEF_{25-75%}). The ratio FEV₁/FVC \times 100 (FEV%) was also calculated; if its value was lower than 70%, the subject was

considered to suffer a bronchial obstruction to airflow. All volumes were expressed in BTPS. The estimated normal values were obtained from Kory, R.C.⁹

In 294 coalminers the lung volume was studied. The subdivisions considered were the residual volume (RV), functional residual capacity (FRC) and total pulmonary capacity (TPC), measured by means of the closed circuit helium dilution method.⁷ Normal values were taken from those published by Bates, D.V.¹

An adapted questionnaire of chronic bronchitis and smoking habits was applied to the coalminers with spirometry function tests.¹³ The smokers were classified according to Brinkman, G.L.³

RESULTS

The results of the chest X-ray reading are presented in Table I.

In the 1,905 coalminers tested there were 20.8% with bronchial obstruction, 1% with a restrictive ventilatory insufficiency and 41.6% with chronic bronchitis. Only 3.6% of those with bronchial obstruction showed an abnormal FEV₁ (less than 80% of the estimated normal). In these miners 29% were smokers and only 1.7% of them were heavy smokers. These low figures prevent the effects of smoking in our results.

Figure 1 shows the prevalence of bronchial obstruction in the non-smoking coalminers, with and without CWP, distributed by age.

The mean values of FVC, FEV₁ and FEV%, expressed in percent of the expected normals, were not altered in these miners and the different CWP categories didn't show any effect over them. The FEF_{25-75%} and the RV/TPC proportion showed, on the other hand, a progressive deterioration in relation to the increased severity of CWP. The differences observed between categories 0/0 and 2/2 were statistically significant. The low number of cases in category 3/3 prevent its statistical comparison.

Table I
Resultados de Radiografías de Torax de Mineros Activos y Retirados
Minería del Carbon (1979-1983)

I.S.T.	0/0	0/1	1/0	1/1	1/2	2/1	2/2	2/3	3/3	A-B-C	TOTAL
ENACAR	2872	343	161	191	84	11	61	15	8	8	3754
	N = 436 (11,6%)					N = 531 (14,1%)					

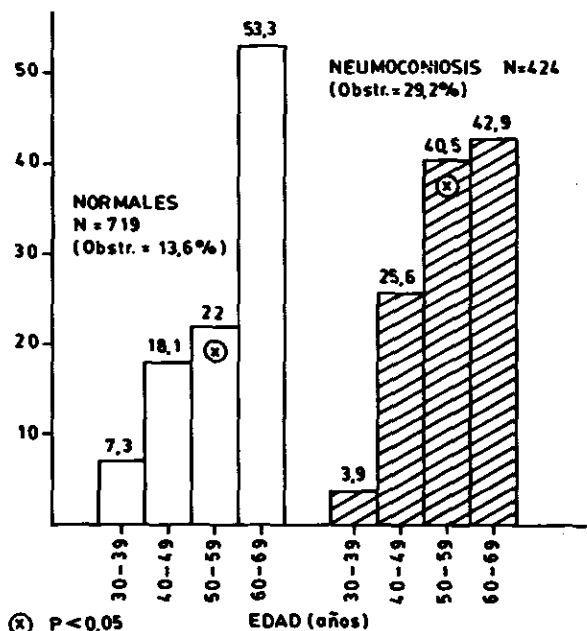

Figure 1. Proporción de casos obstructivos en mineros sin y con neumoconiosis que no fuman.

Table II illustrates the mean values of FRC, RV, and TPC, expressed as the percentage of observed values to predicted normal in relation to CWP categories.

In Table III the effect of bronchial obstruction on the lung volumes can be observed.

DISCUSSION

The prevalence of CWP found in this study (14.1%) was influenced by the selected group of retired miners seeking for compensation, by the fact that they were older and that, at the time of the examination, they already had a presumed diagnosis of CWP. For this reason it is most probable that the prevalence in our active miners is lower.

PMF was until now an unknown entity in our coalminers. The observed prevalence (0.22%) in this sample was very similar to what has been published elsewhere,^{16,12} and points out the similarities of the lung reactions to coal dust.

Bronchial obstruction was more prevalent (20.8%) than what has been found in non-smoking not exposed workers (7.8%) ($P < 0.001$).² The prevalence in the non-smoking coalminers with CWP (29.5%), was higher than what was found in those without CWP (15.6%); but when compared by

Table II
Volumenes Pulmonares Obtenidos por el
Metodo de Dilucion de Helio por Categoría Radiológica

CATEGORIA RADIOLÓGICA	N	\bar{X} C.F.R. % obs / est.	\bar{X} V.R. % obs / est.	\bar{X} C.P.T. % obs / est.
0/0	104	98,0 ±21,3	117,5 ±30	112,4 ±13
0/1	37	94,6 ±20,8	111,2 ±28	111,4 ±14
1/1	123	97,1 ±20	117,3 ±30	112,9 ±13
2/2	25	109,7 ±30	145,5 ±62	118,7 ±22
3/3	5	105,4 ±16	126,2 ±11	118,0 ±9

Table III
Volumen Residual (vr) y Capacidad Pulmonar Total (CPT) en % de lo
Observado/Estimado Normal Segun Categoría Radiológica y Función Ventilatoria

CATEGORIA RADIOLÓGICA	NO OBSTRUCTIVOS			OBSTRUCTIVOS		
	N	CPT %	VR %	N	CPT %	VR %
0/0	83	112,2 ± 13	110,9 ± 25	21	114,9 ± 13	133,7 ± 34
0/1	31	110,9 ± 13	105,5 ± 19	6	114,2 ± 20	140,2 ± 47
1/1	78	109,6 ± 12	106,8 ± 22	45	118,0 ± 13	131,4 ± 34
2/2	17	113,5 ± 17	127,5 ± 28	8	129,8 ± 28	187,5 ± 92
3/3	2	110,5	126,0	3	123,0	126,3

age groups only those between 50 to 59 years continue to show a significant difference. This low involvement of the larger airways in CWP is in agreement to what has been published.^{20,14,19,5}

Coincident with other studies, these coalminers had increased RV, TPC, and RV/TPC when compared to the estimated normal values in the general population.^{17,15} CWP was demonstrated to have a significant effect in the increased RV when comparing categories 2/2 with 0/0 coalminers. Morgan, W.K.C.,¹⁴ Lapp, N.L.,¹⁰ and Churg, J.L.⁴ has suggested that the anatomical changes attached to the localization of the coal macule at the respiratory bronchioles can explain these abnormalities. It is almost certain that the increased small airways resistance in these cases play a major role in the increased RV;¹⁵ and the significant deterioration of the FEV_{25-75%} in relation to the severity of CWP observed in this study is also in keeping with these suggestions.^{5,11}

The absence of an important involvement of bronchial airflows and the proved late emergence of emphysema in CWP, makes it unlikely as an important factor in the etiology or the ventilatory abnormalities in these miners.⁶

The influence of bronchial obstruction on the results of RV was evident, but it was also clear that the non obstructed coalminers continue to show the same lung volumes abnormalities described with lower values. As in the study of Morgan, W.K.C.,¹⁵ it was noteworthy that bronchial obstruction didn't show the same trend in relation to CWP categories as that observed with RV. Again we are inclined to the view that the increased resistance in the peripheral airways is probably the most important factor in these results.

The low prevalence of abnormal values of FEV₁ in these workers is according to what has been described as a functional parameter unrelated to simple CWP,²⁰ and it points out the scant influence of this disease in the respiratory impairment seen in a proportion of these miners. The main offender has always been related with complicated CWP or other severe lung disease.

REFERENCES

1. Bates, D.V., Macklem, P.T., Cristie, R.V.: *Respiratory Function in Disease*. 2nd Ed., pp. 93 W.B. Saunders Co., Philadelphia (1971).
2. Benavides, R.: Influencia de la Contaminación Ambiental y del Hábito de Fumar sobre la Espirometría y Bronquitis Crónica de Trabajadores Industriales. *Anales Méd. Concepción* 24:31 (1984).
3. Brinkman, G.L., Coates, E.O. Jr.: The Prevalence of Chronic Bronchitis in an Industrial Population. *Amer. Rev. Resp. Dis.* 86:47 (1962).
4. Churg, J.L., Wright, J.L., Wiggs, B., Paré, P.D., Lazar, N.: Small Airways Disease and Mineral Dust Exposure. *Amer. Rev. Resp. Dis.* 131:1391 (1985).
5. Hankinson, J.L., Reger, R.B., Fairman, R.P., Lapp, N.L., Morgan, W.K.C.: Factors Influencing Expiratory Flow Rates in Coalminers. *Inhaled Particles IV* (part 2) pp.737-752. Walton and B. McGovern, Eds. Pergamon Press, England (1977).
6. Heppleston, A.G., Leopold, J.G.: Chronic Pulmonary Emphysema. *Amer. J. Med.* 31:279 (1961).
7. *Instruction Manual for the Modular Lung Analyzer* (Book 1) Warren E. Collins Inc., Eds., Braintree, USA.
8. *ILO U/C International Classification of Radiographs of Pneumoconiosis* (Pamphlet 22). ILO revised ed. Geneva (1972).
9. Kory, R.C., Callahan, R., Boren, H.G., Synder, J.E.: Clinical Spirometry in Normal Men. *Amer. J. Med.* 30:243 (1961).
10. Lapp, N.L., Seaton, A.: Lung Mechanics in coal worker's Pneumoconiosis. *Ann. N.Y. Acad. Sci.* 200:433 (1972).
11. McFadden, E.R., Jr., Linden, D.A.: A Reduction in Maximum Mid-expiratory Flow Rate. *Amer. J. Med.* 52:725 (1975).
12. McLintock, J.S., Rae, S., Jacobson, M.: The Attack Rate of Progressive Massive Fibrosis in British Coalminers. *Inhaled Particles III*, Vol. 2 pp. W.P. Walton, Ed. Unwin Bros. Ltd., Surrey, England (1971).
13. Medical Research Council Committee Report: Definition and Classification of Chronic Bronchitis for Clinical and Epidemiological Purpose. *Lancet* 1:775 (1975).
14. Morgan, W.K.C., Lapp, N.L., Seaton, A.: Respiratory Impairment in Simple Coal Worker's Pneumoconiosis. *J. Occup. Med.* 14:839 (1972).
15. Morgan, W.K.C., Seaton, A., Burgess, D.B., Lapp, N.L., Reger, R.: Lung Volumes in Working Coal Miners. *Ann. N.Y. Acad. Sci.* 200:478 (1972).
16. *Annual Report, Medical Service*. National Coal Board, London, 1982-1983.
17. Ogilvie, C., Brown, K., Kearns, W.E.: Overinflation of the Lungs in Coalminers. *Brit. Med. J.* 3:10 (1967).
18. *Respiratory Function Tests in Pneumoconiosis*. *Occupational Safety and Health Series No. 6*. International Labor Office, Geneva (1966).
19. Rogan, J.M., Ashford, J.R., Chapman, P.J., Duffield, D.P., Fay, J.W.J., Rae, S.: Pneumoconiosis and Respiratory Symptoms in Miners at Eight Collieries. *Brit. Med. J.* 1:1337 (1961).
20. Ryder, R., Lyons, J.P., Campbell, H., Gough, J.: Emphysema in Coal Worker's Pneumoconiosis. *Brit. Med. J.* 3:481 (1970).

STUDIES ON PREVENTIVE EFFECT OF ALUMINUM CITRATE ON SILICOSIS

Zou Shiqu* • Liu Hui • Zhou Youyi • Shu Kaiqing • Liu Shijie*

*Dept. of Occupational Health, Beijing Medical University, Beijing 100083, PRC

ABSTRACT

On the basis of experiments, the Al-cit showed its effectiveness in preventing biological effects of silica. A total of 917 cases selected from both engineering corps of railway and coal mines with stage 0 or 0+ by radiographs were studied. All cases were divided into Al-cit group and control group workers with continuing dust exposures. The treatment group workers were injected with Al-cit at a dose of 120 mg Al/person/year and the control group workers received a consolant or nothing during the time of 1980 to 1985. The radiographic changes were demonstrated that Al-cit showed clear-cut effects in both retardation of the dust-induced fibrosis and reduction of the morbidity of silicosis.

Silicosis is always an occupational disease in many developing countries today. Controlling the concentration of dust in the air at workplaces and keeping it in accordance with MAC were main important measures. But it is not easy to achieve MAC in all workplaces. Particularly for a lot of township industries in China, it will be very difficult. Al-cit showed a good effectiveness in preventing biological effects of silica in our other experimental studies.

This paper compared the efficacy of intramuscularly injected Al-cit group and control group in relieving symptoms, in changes of laboratory examinable indices, and in retarding the progression of established radiological changes.

VOLUNTEERS ACCEPTED AND METHOD

It was decided that all volunteers from both engineering corps of railway and coalmines to be included in the trial must (a) have radiological picture of 0 or 0+ stage according to the Chinese roentgenodiagnostic criteria of pneumoconiosis associated with a history of exposure to silica or coalmine dusts over a period of at least 5 years; (b) show no evidence of cardiovascular disease; (c) be deemed likely to attend regularly for treatment over a number of years and be willing to submit faithfully to all necessary tests of assessment.

All volunteers (1048 male workers) were divided into Al-cit group and control group with continuing dust exposures (Table I showed the dust conditions). The treatment group workers were intramuscularly injected with Al-cit 120 mg Al/person/year and control group workers received Vit B₁ (IM) or nothing during the period of 1980 to 1985.

RESULTS

131 accepted volunteers dropped out in the investigation period. Those dropped out because they changed to other workplaces, retired, did not cooperate or did not receive enough Al-cit, more than 180 mg Al in treatment. At the end of 5 years, 519 group Al-cit and 398 group control persons completed the investigation. The lapses rate, age, years of exposure to dust and distribution of type of job did not show any

significance between the two groups (Tables II, III, IV).

All accepted took a radiographic examination once every other year during the period of investigation. The roentgenograms were read and diagnosed by a fixed group of experienced readers according to the Chinese roentgenodiagnostic criteria of pneumoconiosis. Table V shows the progression rate from 0 and 0+ stage group with 1.6%, 10.3% during the period of investigation in the Al-cit group and 12.0%, 26.0% in the control group, i.e., the percentage of retardation of progression of radiograph of silicosis by Al-cit attained 86.6% in 0 stage group and 60.4% 0+ group. Al-cit showed clear-cut effects in both retarding the dust-induced fibrosis and reduction of the morbidity of silicosis. The change in symptoms was assessed by a group of clinical doctors independently, 262 cases in Al-cit group and 180 cases in control group were questioned about their symptoms at intervals during the treatment. Table VI shows the symptoms at incidence of cough, thoradynia, sputum, tympanites in the Al-cit group were decreased more than the control group. 116 cases in the control group received a consolant vit B₁.

Indices of laboratory examination: such as ceruloplasmine, Lysozyme, Ca⁺⁺, GPT in serum and blood and urine rule examination, except those of percent of albumin A in Al-cit group showed increased and globalis gamma decreased by electrophoresis examined, did not show any significant changes between both the Al-cit group and control group.

Table I
Condition of Dust in the Air of Workplace

mine or corp	concentration mg/m ³	free SiO ₂ %	distribution 5u %
A	7.4(4.7-26.1)	12.3(2.8-37.1)	94.8(91.7-96.6)
B&C			
rock	12.6(4.0- 23.0)	21.1	84.5
semicoal	26.6(18.0- 80.0)	11.6	80.3
fullcoal	89.4(40.0-800.0)	8.9	86.4

Table II
Number of Accepted Volunteers to Drop Out at Different Times of the Investigation

group	started	1982		1985		total
		2 year lapses	invest	5 year lapses	invest	
Al-cit	588	33	555	36	519	69/588(11.7%)
control	460	28	432	34	398	62/460(13.5%)

Table III
Distribution of Workers' Age and Years of Exposure to Dust

group	n	age(yr)	dust exposure(yr)
Al-cit	519	42.45±0.29	15.46±0.22
control	398	42.80±0.38	15.69±0.33

Table IV
Distribution of Type of Job Between the Two Groups

group	type of job				total	
	driller	trans- porter	many sided worker	others		
Alcit	n	235	100	155	26	519
	%	45.3	19.8	29.9	5.0	100.0
control	n	171	104	99	24	398
	%	43.0	26.1	24.9	6.0	100.0

Table V
The Radiographic Changes with Al-cit to Prevent Silicosis

group	total	after treatment		progression rate %	P
		no prog	prog		
Al-cit	306	301	5	1.6	0.01
control	225	198	27	12.6	
Al-cit	213	191	22	10.3	0.01
control	173	128	45	26.0	

progression: 0 into 0+ or I; 0+ into I or II

DISCUSSION

Since the 1930s, a lot of experimental studies and clinical investigations have been reported in literature, which suggest that the therapeutic inhalation of metallic aluminium dust is beneficial to silicosis. But from the mid 1940s to the early 1950s, there is the important additional feature that inhaled aluminium dust may itself be capable of causing diffuse interstitial fibrosis. Over ten years ago, the efficacy of aluminium chlorohydroxyalltoate inhalations in reducing fibrosis of rats which suffered quartz dust was reported by Policard (1966) and Bouffant (1967, 1977). Unfortunately, we have not found the practical report about it. As we know insoluble aluminium (as metallic Al) dust inhalation might be

retained and demonstrated to cause fibrosis in lung. According to the experimental study, Al-cit intramuscularly injected on rats which suffered silica dust, the Al contents in lungs increased more than that in livers and kidneys (Table VII). It may be very useful to prevent silicosis with Al-cit, but intramuscular injection is not an ideal method to give the medicine for every recipient. So to find a more ideal method would be necessary to study in the future.

The results of this study showed that retarding progression rate of radiographic of silicosis by Al-cit attained 86.6% in 0 group and 60.4% in 0+ group for the investigation period of 5 years. The retarding rate of both treated groups showed

Table VI
Symptom Level of Al-cit Group and Control Group

variable	Al-cit group (n 262)		Control group (n 180)	
	1980	1985	1980	1985
cough (%)	20.2	6.9	13.9	11.2
thoracodynia(%)	21.8	10.8	13.3	11.2
sputum	18.9	5.0	13.9	10.0
tympanites	11.8	7.6	10.6	17.8
electrophoresis				
albumin(%)	68.7	70.1		
globulins(%)	15.6	15.1		

Table VII
Al Content in Lung, Liver, and Kidney of Rats Compared
Between Injected and Not Injected Al-cit

organ	normal		suffered quartz dust	
	control	injected Al-cit	control	injected Al-cit
lung				
ug/g	10.36±0.71	12.40±0.31	5.29±0.38	17.13±1.12
ug/total	23.01±1.72	28.73±1.12	37.05±2.68	98.41±6.76
liver				
ug/g	5.50±0.40	21.0±0.96	4.77±0.40	5.08±0.22
ug/total	83.78±5.60	326.59±4.96	59.23±5.76	66.10±3.50
kidney				
ug/g	7.82±0.38	32.60±1.35	4.88±0.25	6.83±0.55
ug/g total	79.70±1.13	85.70±5.30	11.37±1.20	16.64±1.32

a significance in comparison with each control group.

In this investigation we did not notice any toxicity or side effects from the use of Al-cit.

How to prevent or retard the fibrogenesis of inhaled silicon dust is an important problem. On the basis of our result, the Al-cit complex may be a practical method to cope with it.

SUMMARY

A controlled trial of Al-cit intramuscular injections in the prevention of ERC and coalmine workers silicosis with continuing dust exposures was conducted over 5 years. Retarding progression rate of radiographic by Al-cit attained 86.6% in

0 group and 60.4% in 0+ group. Al-cit does not show any toxicity and side effects from this study condition. This investigation shows that the Al-cit may be a practical method to prevent the fibrogenesis of silicon dust in body.

REFERENCES

1. Liu Shijie, Zou Shiqu: The studies of prevention and treatment of silicosis by Al-cit. Collected paper from Dept. of Occupational Health Beijing Medical College V.3, 1983.
2. Zou Shiqu: The present and history of aluminium and silicosis. Collected paper from Dept. Occupational Health V.4, 1978.
3. Policard, A. et al: *Fort staub Lungenforschung* 2:25, 1967.
4. Le Bouffant, L. et al: *C.A.A. Acad. Sci (D)* 268:3001, 1969.
5. Le Bouffant, L. et al: *Inhaled Particles IV*: 389, 1977.

RETROSPECTIVE MORTALITY STUDY OF ASBESTOS WORKERS IN LAIYUAN

ZOU SHIQU* • Wu Yongxian • Ma Fusheng* • Ma Hongshuen • Sueng Wenzhi* • Jiang Zhenhuan*

*Dept of Occup. Health, Beijing Medical University, Beijing, 100083, China

A retrospective cohort study was conducted at a chrysotile mine in Laiyuan, Hebei province 1972 and 1981. Mortality rates among 1227 men who had worked at the mine for at least one year before 1972, were compared with those among 2754 local residents of Laiyuan commune who apparently had never been exposed to asbestos. Between 1972 and 1981, there were 67 deaths in the asbestos workers and 247 deaths in the commune residents. Standardized rates of mortality from all cases, malignant tumors and lung cancer were 924.3, 433.6, 344.4 per 100,000 persons in the miners and 836.8, 62.9, 14.3 per 100,000 in the commune residents. The rates of mortality from malignant tumors and lung cancer differed significantly between the two groups ($p < 0.001$). Three cases of mesothelioma were observed in asbestos workers, the mortality rate, 24.9 per 100,000 persons. The lung cancer mortality rate among asbestos workers tended to be higher in 1977-1981 than 1972-1976.

In order to survey the incidence of tumor of asbestos miners and work out the prevention measures of the asbestos hazard, we made retrospective cohort study about the asbestos miners in Laiyuan, Hebei province.

GENERAL INTRODUCTION

The asbestos mine of Laiyuan is located at central-west part of Heibei province; east of Taihang mountain. Its main product is chrysotile. The country rocks are dolomite serpentine, marble and little quartz rock. There were no other industrial pollution sources within 10 kilometers of the asbestos mine. The food was supplied mainly by the Laiyuan city, which is 30 kilometers away from the asbestos mine.

The asbestos in Laiyuan has been exploited for 60 years; after 1949 it was changed into state-run. The output and number of workers began to increase in the late 1950s. This mine was gallery exploited by handwork in the early time. The asbestos selecting rooms of mechanization were put into operation in the latter half of 1954; the dust in the air of working condition was very high, as follows: 1168-1453 mg/m^3 gallery drilling, 356.8 mg/m^3 dressing. To follow the development of production, the mechanic ore dressing and dust eliminating apparatus was used and then, the dust concentration began to decline. However, the dust concentration in the major dust-producing workplaces still go beyond mg/m^3 (which is the national hygienic standard). The dust concentrations over the years are: mining $26.8 \pm 4.4 \text{ mg}/\text{m}^3$ varied 0.5-80 mg/m^3 ; dressing $29.7 \pm 4.2 \text{ mg}/\text{m}^3$ varied 0.5-80 mg/m^3 . The dust

AED 5 μm is 80%, free SiO_2 in the original asbestos is 1.5%, the subsiding dust in dressing is 3.6-6.2%.

There are 1500 asbestos miners in the asbestos mine. Many older workers who were employed before 1949, when the mine was established had been exposed to high concentrations of dust. Up to now, the grand total of the asbestosis was 154 and a number of malignant tumors occurred among the asbestos miners.

THE OBJECT OF SURVEY, CONTENT AND METHOD

We investigated the male asbestos miners who registered on January 1st, 1972 and were exposed to asbestos at least one year. We wanted to know their incidence and mortality rate (MR) of malignant tumor, from January 1st, 1972 to December 31st, 1981.

In order to choose the case population, we selected such people in Laiyuan commune to take the control group, their living conditions and medical services are the nearly the same as the asbestos miners. They are never exposed to asbestos and other carcinogens. They registered on January 1st, 1972, and are older than 15 years.

The trained interviewers collected the register of object respectively for the asbestos mine. The register would be collected from labor card and health management card and be examined; for the commune the register would be collected from residence card of the police office. After that, each register would be checked according to questionnaire. The dead was traced for cause from hospital death certification. The smokers were questioned by the survey staffs. Information about the dead was supplied by the relatives or the insiders. The dust concentrations of working environment were supplied by occupational health and safety department of the asbestos mine or local anti-epidemic station in Bao Ding or other unit; the materials of the two groups were standardized for the sake of easy comparison.

RESULTS

The response rate of asbestos miners group and the commune residents group are as follows: 99.9%, 99.3%, the malignant tumors were diagnosed by the county hospital, asbestos mine hospital and other advanced hospital, the lung cancers were diagnosed above grade II (shown in Table I).

1. The death toll of asbestos miners was 67.24 deaths from malignant tumor in which 9 people died from lung cancer (3 mesothelioma). On the other hand the death toll of the commune residents was 246.16 deaths from malignant tumors in which 3 people died from lung cancer. After standardization, the death rate (mentioned above) of asbestos mines are significantly higher than those of the commune residents (Table II). The ratio of standard MR of lung cancer in asbestos mines was 24.

In the cohort study of asbestos miners, there were 154 cases of asbestosis, among which 14 died (7 died from malignant tumors and 6 died of lung cancer). The rate of asbestosis with lung cancer complications is 3.9%. Lung cancer percentage in the death cause of asbestosis is 42.9%.

2. The distribution of two groups of death cause is different. On one hand, in the asbestos mine, the former six death causes were 96% of the total death cause. Its order is as follows: malignant tumor, respiratory disease, stroke, coronary heart disease and other cardiac disease, brain vessel disease. On the other hand the

former six death causes were 83% of the total death cause in the commune, its order is as follows: other heart disease (mainly cor pulmonale), respiratory disease, brain vessels disease, stroke, malignant tumor infectious disease. It is clear that the malignant tumor is the first death cause and 32% of the total death cause in the mine. It is very striking.

3. Lung cancer was 41% of all deaths caused by malignant tumor of asbestos miners, stomach cancer and liver cancer come second. Stomach cancer and esophagus cancer occupy the first death cause, together they are 63% of malignant tumor for commune residents. We should pay much attention that MR of lung cancer of asbestos mine is very high. In addition, there are three cases of mesothelioma which occurred rarely in general population, however, the MR of the mine is so high as to reach 24.91 per 100,000. The trend of MR of malignant tumor from the former five years (1972-1976) and later five years (1977-1981) were 125.4, 152.9 per 100,000 in the miners and 81.8, 24.3 per 100,000 in the commune residents. The prevalence rate of lung cancer is 27.9 in the former five years and 82.3 in the later five

Table I
The Diagnosis Grade of Two Groups

group	tumor category	grade of diagnosis*				total
		I	II	III	IV	
asbestos miners	lung cancer	3(33.3)#	6(66.7)	---	---	9(100.0)
	the others	7(46.7)	8(55.3)	---	---	15(100.0)
commune	lung cancer	---	3(100.0)	---	---	3(100.0)
	the others	---	11(84.6)	2(15.4)	---	13(100.0)

* national census of tumor in 1973-75.

out of the brackets are cases, in the brackets are percentage.

Table II
Comparison of the SMR Between Asbestos Mine and Commune

	all cases	all malignant tumor	lung cancer
asbestos mine	926.3	433.6	344.4
commune	836.8	62.9	14.3
p	0.001	0.001	0.001

years for the asbestos miners, and 13.6 and 6.0 in the commune residents. The trend of MR of all malignant tumor and lung cancer is increasing. This is in accordance with long latency period of lung cancer in the asbestos miners.

DISCUSSION

The reliability and comparison between the exposure group and control group is the key problem of the survey. The response rate of the survey is over 99%, interviewers were all professional and well trained before the survey, the survey was conducted according to the uniform plan. The death cause was confirmed in the clinical service, in which the deceased was diagnosed and confirmed by case report or doctors who were responsible for the dead.

The diagnosis level of malignant tumor between the two groups was similar. All were diagnosed above the county level hospital. 2 cases of malignant tumor in commune residents were diagnosed grade III (12.5% of all malignant tumor); the others were diagnosed grade I-II. In order to achieve the reliability of original material, we checked all the problems of the survey, so we think the material is reliable.

As to the comparability between the control group and exposure group, we think it is comparable, reason: 1) The geography condition and diagnosis level of the two groups are similar. 2) For the commune residents, MR of all death cause, all malignant tumor and lung cancer are similar to those of retrospective cohort study on death cause of Bao Ding area and in Xin Cheng County in 1974-1976, those are nearly Laiyuan. 3) The age constitution of the two groups population is a bit different. This is related to the special age constitution of asbestos miners; this problem can be solved by standardization. After standardization, we find that the indices of the asbestos miners which include, MR of all death causes, all malignant tumor and lung cancer are higher than that of the commune residents. Its difference is significant. It implies that there are special factors which make the MR of lung cancer of asbestos miners higher than that of the commune residents.

We should analyze the reason why the SMR of malignant tumor is higher than that of the commune residents. Beside the difference of the lung cancer between the two groups, the SMR of stomach cancer of asbestos miners is higher than that of commune residents. The SMR of lung cancer will increase in such conditions: industry population and smoking. There are no industrial sources of high incidence of lung cancer near the local district. On the contrary, the commune residents whose living and natural conditions are similar to the asbestos mine, have lower prevalence of lung cancer than the asbestos miners. The survey on the death cause in 1979 to 1981 showed the rude MR of lung cancer in Bao Ding city was 8.17 per 100,000, the country side of Xing Cheng 8.22 per 100,000, the commune residents 9.63. These are lower than that of the asbestos mine. It implies that the industry pollution or the local reasons which make the high incidence of the lung cancer of the asbestos mine do not exist.

The material of the recent years proved that lung cancer is closely associated with smoking, but this survey indicates that the MR of lung cancer has no significant relationship with

smoking in miners (p 0.1) and with smoking in commune residents (p 0.9).

The survey also indicates that smoking is not the main cause which makes the higher MR of lung cancer of the asbestos miners, but people who smoke and are exposed to asbestos have much higher MR of lung cancer than those who smoke without exposure to asbestos at the same time (p 0.01).

The relationship between the death from lung cancer and type of job or year of asbestos exposure is shown in the following:

Exposure (years)	5	5-	15-	25
Incidence of lung cancer (%)	0	0.35	0.61	2.42

The relationship of the incidence of lung cancer and the year of asbestos exposure dust is as follows:

$$(y=0.1035x - 0.9433 \quad x: \text{year} \quad y: \text{incidence} (\%) \quad r=0.918 \quad p 0.01).$$

The relationship between the incidence of lung cancer and type of job is as follows: miller 1.44%; management of production 1.33%.

The materials show that the incidence of lung cancer is associated with purity of asbestos and exposed time. This is the same as the general report, that the incidence of lung cancer of asbestos processing is higher than that of asbestos mining.

We can come to the conclusion that the high MR of lung cancer is mainly associated with asbestos. The shortest time of cancer onset is 24 years, the longest time is thirty-two and four months. The mean value is 28.18 years (28.18 ± 0.83). The cancer worsened quickly after diagnosis, the time from diagnosis to death is about six months (6.33 ± 2.08). There is no discovery of the lung cancer among the miners whose exposure to asbestos is less than 5 years. In this survey three cases of mesothelioma were found. The cause of death from malignant tumor in the general population is about 1-3 per 100,000, but in the asbestos mine of Laiyuan it is as high as 4479 per 100,000.

SUMMARY

1. The retrospective cohort study was conducted at chrysotile mine and comparison was made with commune residents in Laiyuan during 1972-1981. The SMR from all cases, malignant tumor, and lung cancer were 924.3, 433.6, 344.4 per 100,000 persons in the miners and 836.8, 62.9, 14.3 per 100,000 in the commune residents. The SMR of malignant tumor and lung cancer differed significantly between the two groups (p 0.001).
2. The MR of the lung cancer of the asbestos mine is closely associated with dust of asbestos. Smoking and exposure asbestos can make the MR of lung cancer increase. Abstinence of smoking and no smoking should be advocated among the asbestos exposed workers.
3. The trend of the MR of lung cancer in the asbestos mine in Laiyuan is ascending. All this predicts that the peak of the lung cancer of this asbestos mine is coming, so it is important to take steps to prevent it.

SMOKING AND RADIOLOGIC OPACITIES IN U.S. NAVY ASBESTOS WORKERS

A.M. DUCATMAN • B.F. Withers • W.N. Yang

U.S. Navy Environmental Health Center, Norfolk, VA 23511-6695, USA

ABSTRACT

The United States Navy's Asbestos Medical Surveillance Program monitors current civilian and military employees who have histories of asbestos exposure. The prevalence of radiologic opacities \geq ILO category 1/1 was 3.9% for 32,233 smokers versus 0.48% for 13,414 for non-smokers, giving an age-adjusted risk ratio of 2.29. The prevalence difference between smokers and non-smokers persisted in all age groups, and was greatest in the more than 11,000 surveyed workers older than 50 (risk ratio 2.58). These data lend support to a persistent role for smoking in the development of radiologic opacities, and further suggest that the potentiation increases with age through the period of employment.

No Paper provided.

THE DISTURBANCE OF BREATHING MECHANICS IN RATS AFTER INTRATRACHEAL INSTILLATION OF RESPIRABLE COAL MINE DUSTS

J. ROSMANITH • M. Stankewitz

Abteilung Hygiene und Arbeitsmedizin der Medizinischen Fakultät der Rheinisch-Westfälischen
Technischen Hochschule Aachen, Klinikum, West Germany

ABSTRACT

The effect of airborne coal mine dust intratracheally instilled on the breathing mechanics of rats was tested with a body plethysmograph. Six months after instillation of airborne coal mine dust high in minerals, a greater loss of specific conductance resulted than with instillation of a mineral poor dust. The finer fraction of the mineral rich dust reduced the specific conductance more considerably than the coarser fraction of the same dust.

No Paper provided.

THE PHYSICAL CHARACTERISTIC OF DUSTS APPLICATED INTRATRACHEALLY IN RATS IN THEIR DISPERSED AND SUSPENDED STATE

J. ROSMANITH • S.B. Schyma

Abteilung Hygiene und Arbeitsmedizin der Medizinischen Fakultät der Rheinisch-Westfälischen Technischen Hochschule Aachen, Klinikum, West Germany

ABSTRACT

Theoretical formulae are clearly presented necessary to characterize tested dust applied by intratracheal instillation or by intraperitoneal injection. It is a question of the characteristic physical dimensions, that must be determined in dispersed states of dusts directly: e.g., the density, the specific adsorption total surface per mass and volume or indirectly as the surface structure number, the hypothetical minimal surface per mass and volume or the number and volume distribution. Artificial dust mixtures applied in animal experiments were characterized in detail in a dispersed state by the estimation of the minimum mass, the homogeneity and inversion rate as well as the difference in the density and the specific adsorption surface. The ascertained changes in density and surface indicate the existence of chemisorption between the dust particles of mixtures as well as their different stabilities and surface activity. New crystals were formed by the mixture of single dusts; i.e., new substances, that could not be reckoned on and in mixtures reacted differently than if applied separately. The physical state of applied dust suspensions in animal experiments were characterized by two different methods of quantification. The first group has separate independent values such as surface tension, permeability coefficient and pH values; the separate independent values of the second group were the specific conductivity, the total molecule and total molecule ion numbers as well as the density. The adequate ascertainment of the values of the dust samples in a dispersed state explains the relationship between these values and the biological action of the dust samples to be demonstrated.

No Paper provided.

SILICOSIS AMONG STONE MORTAR WORKERS IN NORTHERN THAILAND, 1986

ORAPUN METADILOGKUL,* M.D., Board Cert. in Preventive Medicine • Amporn Ithiraviwong,† M.D., Ph.D. • Ponglada Supanachart,‡ M.D., Board Cert. in Radiology • Surapong Pimiam,§ M.D., Board Cert. in Internal Medicine

*Bangkok, Thailand

†Mahidol University, Thailand

‡Chest Disease Hospital, Nonthabury, Thailand

§Payao Provincial Hospital, Payao, Thailand

BACKGROUND

The high rate of premature death (death at age of 30–40 years old) was found in a group of villages in Payao Province, Thailand. These villages had been named as the village of widows. The main occupation in these villages is the production of stone mortar and pestles. This doubtful situation led to at least three field investigations to find the cause of premature death in such villages. There were no definite reports of silicosis among these mortar workers in the villages, except a lot of tuberculosis cases could be reviewed from the routine tuberculosis registration at the local health authority. From working conditions with stone containing a high percentage of quartz and increasing prevalence of tuberculosis among these mortar workers, we carried out a cross-sectional epidemiology study of silicosis and a risk factor study on silicosis to confirm the silicosis cases existing in the village, explain silicosis distribution among the stone mortar workers and to identify risk factors on silicosis.

The effects of silicosis, the chronic fibrosis of the lungs produced by prolonged and extensive exposure to free crystalline silica, have been recognized for centuries. Pulmonary disease produced by dust is mentioned by Agricola in his Treatise on Mining and is described in stonecutters by Van Diemerbroeck Ramazzini.¹ Clinical evidences of previous exposure to free silica in old mines, abandoned quarries, and ancient flint tools and weapons were demonstrated.² Silicosis is caused by the inhalation and retention of dust containing silica in occupations such as mining, tunnelling, quarrying, stone dressing, sandblasting, fettling, boiler scaling, and in pottery, ceramics and brick manufacture.³ Symptoms of silicosis cases are increasing dyspnea, non productive cough and chest pain, progressing to compensatory emphysema and cor pulmonaly.⁴ There was a report of silicosis among miners with the prevalence of 19.48% (5,366/27,553) together with pulmonary tuberculosis of 13.83% (742/5,366).

In Thailand, there were no epidemiological reports of silicosis prevalence among particular occupations, but we did have the first case report of silicosis who was a worker in a wulfraum mine.⁶

METHODS

A cross-sectional morbidity study of stone mortar workers in three villages at the Northern Part of Thailand was carried out in January 1986. Detailed occupational, smoking, and respiratory histories were obtained on questionnaires by trained interviewers. Physical examinations, pulmonary function tests and chest radiographs were also performed. A case-control study was also conducted by randomly selecting non-case workers in the same plant at ratio case: control of 1:3.

For physical examinations, the respiratory signs concerned were basal crepitation which dry end-inspiratory crackles were heard and did not clear with cough, chest expansion, cyanosis, and clubbing fingers. The pulmonary function tests were obtained using the spirometer. Test results derived included forced expiratory volume in one second (FEV₁) and forced vital capacity (FVC). Three efforts were obtained. The maximal FEV₁ and FVC were selected. The FEV₁ and FVC maneuvers were considered reproducible if the 2 best values for each agreed within 5% of the larger value or 100 ml, whichever was greater. Predicted values based on age, sex and height for FVC, FEV₁ and FEV₁/FVC were obtained from the prediction equation of Crapo and coworkers.⁷ The predicted values was corrected with 0.85 for non-caucasian people.

For chest radiography, posteroanterior and lateral chest radiographs of 16*17 inches films at a standard distance of 72 inches at 11 kvp. Interpretation was carried out by a radiologist and an occupational health physician by using the ILO-1980 international classification of radiographers of the pneumoconiosis.⁸ The case definition of silicosis used was a mortar worker with chest radiograph of fibro-nodular profusion at 1/1 and above.

For statistical analysis, the prevalence rate of silicosis was calculated by age specific groups, job, duration of work, worksite, smoking habit and cloth using instead of approved masks. In case-control study, Chi-square and Student's t-tests were used to calculate the significance of factors between cases and control.

RESULTS

Fifty six cases met the silicosis case definition from 266 stone mortar workers which provided the prevalence rate of 21.1%. Mean age among cases was 40.7 years with median and mode of 35 and 38 years respectively. The age range was 15–59 years. The highest prevalence rate of 43.3% (13/30) was among the workers of 50–59 years age groups, together with 32.1% and 30.8% among the 40–49 and 30–49 years age groups respectively. The specific prevalence rate by duration of work was highest among the workers aged between 21–25 years with the rate of 66.6% (6/9). The sex specific prevalence rates were 29.1% (46/158) among male and 9.3% (10/108) among female. The prevalence rate by job was 28.7% (39/136) among the workers making stone mortars which was higher than the ones making stone pestles. To work inside building had the higher rate of 31.5% (23/73) than to work outside the building of the rate 17.1% (33/193). The workers who used clothes covering their noses and mouths during work had 24% (36/150) of silicosis prevalence rate, and the ones who did not use the clothes had silicosis prevalence rate of 17.2% (12/116). The smokers had 18.8% (39/208) of silicosis prevalence rate and non-smokers had 29.3% (17/58). Clinical symptoms were 75% chest pain, 71% dyspnea, 53% chest tightness, and 50% weight loss. The cases had abnormal physical examinations of 55% cyanosis, 53% clubbing fingers, 53% decrease chest expansion less than 3 centimeters, 50% decrease breath sound. All cases had abnormal ventilatory defect, with 92.8% (52/56) of restrictive ventilatory defect.

Chest radiographs were with shapes and sizes of p and q with the most profusion of 2/3 (28.6% by Table I). There were 7 cases from 56 cases that had large opacities, and 57% (4/7) was 'B' type. There were some other abnormalities consistent with pneumoconiosis including tuberculosis at 25% (13/52), cavity at 15.4%, definite emphysema at 13.6%, ill-

defined diaphragm at 9.6%, enlargement of hilar or mediastinal lymphnodes at 9.6%, calcification in small pneumoconiotic opacities at 7.7%, abnormality of cardiac size or shape at 5.8%, pleural thickening in interlobar fissure or mediastineum 3.8%, eggshell calcification of hilar or mediastinal lymphnodes at 3.8%, bullae at 1.9%, ill defined heart outline at 1.9% and honeycomb lung at 1.9% (Table II).

In case control study, there was no significant difference between 56 cases and 168 randomly selected control in terms of smoking habit and using clothes instead of approved masks. The men were ill more than female significantly ($p < 0.05$, or = 3.5). The cases were older than the controls significantly ($p < 0.05$, OR = 2.8). The ones who worked with longer period had more likelihood to be case, more than the ones who worked with shorter period significantly ($p < 0.05$, OR = 2). The workers who polished mortars had the chance to develop silicosis 8 times higher than the ones who did not polish the mortar ($p < 0.05$, OR = 8).

DISCUSSIONS AND RECOMMENDATIONS

To prevent workers from exposure to silica is among the highest priorities in protecting the health of the workers. As silicosis is not reversible. If one gets the disease, one will be affected for the rest of one's life. Thus, this epidemiological study aimed ultimately to such prevention. As one definition of epidemiology is the study of distribution and determinants of the disease. The classical process consists of examining a series of variables to ascertain causation including age, sex, socioeconomic status and other. It is known that silica causes silicosis, but there were several major difficulties involved in attempting to do this, which were difficulties in the accurate determination of exposed dose, difficulties in the accurate determination of the health effects and difficulties in dealing with competing variables such as cigarette smoking and host susceptibility.⁹ This study of health effects from silica was

Table I
Small Opacities of Parenchymal Abnormalities by Profusion
among Silicosis Patients in Northern Thailand, 1986

Profusion	Number	Percentage
1/1	6	10.7
1/2	4	7.1
2/1	12	21.4
2/2	8	14.3
2/3	16	28.6
3/2	9	16.1
3/3	1	1.8
3/4	0	0.0
All types	56	100.0

Table II
Other Abnormalities Consistent with Pneumoconiosis
among Silicosis Patients in Northern Thailand, 1986

Type	Descriptions	Number	percentage
bu = bulla(e)		1	1.9
cn = calcification in small pneumoconiotic opacities		4	7.7
co = abnormality of cardiac size or shape		3	5.8
cv = cavity		8	15.4
em = definite emphysema		7	13.5
es = eggshell calcification of hilar or mediastinal lymph nodes		2	3.8
hi = enlargement of hilar or mediastinal lymph nodes		5	9.6
ho = honeycomb lung		1	1.9
id = ill-defined diaphragm		5	9.6
ih = ill-defined heart outline		1	1.9
pi = pleural thickening in interlobar fissure or mediastinum		2	3.8
tb = tuberculosis		13	25.0
All Abnormalities		52	100.0

performed even though there were many constraints mentioned above, because we wanted to provide useful findings used in prevention and control of silicosis. From the study, it seems that the ones who were exposed with mortar polishing need to be protected from free silica more than others. To work inside the building is more dangerous than to work outside. To wear clothes instead of approved masks is not useful and may be harmful, thus the workers should wear approved masks.

Since there were 25% of tuberculosis among silicosis workers or silicotuberculosis in this study in the high tuberculosis prevalence country, when it is compared to the study among miners,⁵ we recommended all pulmonary tuberculosis to be referred for further management in the chest hospital or special clinic concerned with silicosis.

Cases of definite silicosis (ILO-1980), classification of "p 1/1" and above aged below 35 years and who are symptomatic should preferably not continue in work with silica exposure. All definite silicosis cases must be followed up annually to exclude complications (e.g. pulmonary tuberculosis, chronic bronchitis and cardiac failure).

For reduction of stone dust at worksite, we recommended wet process in appropriate way.

REFERENCES

1. Ziskind, Morton, Jones, Robert N., Weill, Hans: Silicosis. *Am. Rev. Respir. Dis.* 113(5):643-661.
2. Hunter, D.: *The Disease of Occupations*, pp. 841. Little Brown and Company, Boston (1955).
3. Crompton, Graham K.: *Occupational Lung Diseases*, pp. 178-184. Oxford: Blackwell Scientific Publications, London (1980).
4. Tyrer, F.H., Lee, K.: *A Synopsis of Occupational Medicine*. Redwood Burn Limited, Trowbridge & Esher (1970).
5. Sand, Rane: *The Advance to Social Medicine*. Staples Press (1952).
6. Shinachot, Ninat: Pneumoconiosis. *Thai Med. Assoc. J.* 376:369-380 (1954).
7. Capro, R.O., Morris, A.H., Gardner, R.M.: Reference Spirometric Values Using Techniques and Equipment that Meet ATS Recommendations. *Am. Rev. Respir. Dis.* 123: 659-664 (1981).
8. International Labour Office: *Guidelines for the Use of ILO International Classification of Radiographs of Pneumoconioses*. Revised Edition 1980. International Labour Office Occupational Safety and Health Office. Geneva (1980).
9. Peter, John M.: *Silicosis*. In: James A. Merchant. *Occupational Respiratory Diseases*. US Government Printing Office, Washington, D.C. (1986).

ACKNOWLEDGEMENTS: The authors would like to acknowledge Dr. Chinoth Husumrer, Director of Division of Occupational Health, Thailand and Dr. Jongrak Kulasert, Director of Payao Provincial Hospital, Thailand, Prof. Dr. Hjordis Foy of University of Washington, Seattle, Dr. Nicholas Wright of University of Robert, New Jersey, USA.

SILICOSIS AMONG WORKERS IN REFRACTORY BRICK FACTORY, THAILAND

ORAPUN METADILOGKUL,* M.D., Board Cert. in Preventive Medicine,
Ministry of Public Health • Ponglada Supanachart,† M.D., Board Cert. in Radiology

*Bangkok, Thailand

†Chest Disease Hospital, Nonthaburi, Thailand

BACKGROUND

Silicosis is a pulmonary fibrotic lung disease caused by inhalation of high concentrations of very fine free silica dust particles. The main industries and occupations at risk are mining, quarrying, manufactures of ceramics, sand blasting, and brick manufacturing.¹

A case of more than ten years of diagnosis as pulmonary tuberculosis from refractory brick factory, had no improvement of tuberculosis treatment, went to the National Chest Disease Hospital and received transbronchial biopsy revealed silica particles in the tissue under polarized light microscope. His job was to weigh the ground raw material used in production of refractory brick. This case was reported to the Division of Occupational Health. To study the magnitude of silicosis among the workers in that factory was necessary to be performed to identify the risk factors on silicosis developing, thus the epidemiological study of silicosis was conducted through this factory.

Despite the fact that silicosis has been a common, occupationally related disease for many years, only a few studies have been directed toward its epidemiologic aspects.² The study by Renes et al. involving iron foundries found 9% of silicosis prevalence rate among 2,000 workers and 25.8% of prevalence rate among those who had worked for 20 or more years.

Among workers in the brick plants, one of the studies was in an Ontario brick plant in which it was claimed that there were no cases of silicosis.³ A study done earlier by Keatinge and Potter revealed similar results among workers in British brick work.⁴ The study in a Pennsylvania brick works came up with different results.⁵ The material used to make brick was significantly different from that in Ontario; it contained more quartz and less aluminum. The prevalence rate of silicosis was very high in this population. Silicosis was found at all levels of exposure, except below 2 mppcf. It was found to be more prevalent in workers involved with burned brick than "greener" brick. The silica content of both was high.

The refractory brick plant in this study is the one established in Thailand, started operating in 1953. It served initially to produce fireclay refractory bricks for cement kiln linings, heating furnace walls runner bricks for steel ingot casting. There were two tunnel kilns and highly equipped machinery.

This factory produced fireclay brick, refractory castables, plastic refractory, mortars ramming mixes, gunning mixes, and insulating firebrick.

The process used in this refractory brick production was crude crushing, impact crushing, ball milling, clay grinding, size screening, vibrating milling, weighing by car, mixing, process of tamping or pressing or ramming or hand moulding, burning and packing.

Silica contents in the products were 31.2–58.7% in fireclay brick, 7.3–46.2% in high alumina brick, 51.9% in fireclay base castable, 59.6% in heat setting mortar, 46.5 in air setting mortar, 9.0–14.9% in plastic refractory, and 51.8–68.2% in the insulating firebrick.

Thus, this refractory brick plant used the material of rather high content of silica when it was compared to other brickworks. This study had the golden aim in prevention and control of such a disease.

METHODS

A cross-sectional descriptive study was designed and self-administered to collect the essential data concerning age, sex, race, job, duration of work, smoking habit, mask wearing and respiratory history, from all of the workers in the refractory brick plants. Physical examinations, pulmonary function tests and chest radiographs were also performed. A case-control study was also conducted by randomly selecting non-case workers in the same plant at ratio case : control of 1:3.

For physical examinations, the respiratory signs concerned were basal crepitation which dry end-inspiratory crackles were heard and did not clear with cough, chest expansion, cyanosis, and clubbing fingers. The pulmonary function tests were obtained using the spirometer. Test results derived included forced expiratory volume in one second (FEV₁) and forced vital capacity (FVC). Three efforts were obtained. The maximal FEV₁, and FVC were selected. The FEV₁ and FVC maneuvers were considered reproducible if the 2 best values for each agreed within 5% of the larger value or 100 ml, whichever was greater. Predicted values based on age, sex and height for FVC, FEV₁ and FEV₁/FVC were obtained from the prediction equation of Crapo and coworkers.⁶ The predicted values were corrected with 0.85 for non-caucasian people.

For chest radiography, posteroanterior chest radiographs of 16*17 inches films at a standard distance of 72 inches at 11 kvp. Interpretation was carried out by a radiologist and an occupational health physician by using the ILO-1980 international classification of radiographs of the pneumoconiosis.⁸ The case definition of silicosis used was a mortar worker with chest radiograph of fibro-nodular profusion at 1/1 and above.

For statistical analysis, the prevalence rate of silicosis was calculated by age specific groups, job, duration of work, worksite, smoking habit and cloth using instead of approved masks. In case-control study, Chi-square and Student's t-tests were used to calculate the significance of factors between cases and controls.

RESULTS

There were eighteen cases of silicosis that met the definition from 190 workers in the plant. The whole plant prevalence rate was 9.5% (18/190). Mean age of cases and mean duration of work were 49.6 (range = 42-56) and 23.9 (10-32) years. Female prevalence rate was 27.8% (5/18), while male rate was 7.6% (13/172). When prevalence rate was classified by position, it is found that prevalence rate among workers was 9.8% (17/173) and rate among foremen was 5.9% (1/17). The prevalence by section was highest among workers in production section 'B' of 13.3% (2/15) followed by 11.5% (13/113) in production section 'A', 6.1% (2/33) in maintenance section, and 4.5% (1/22) in quality control and technical section. When it was considered by job description, the highest prevalence rate was 15.7% (8/51) among those who prepared raw material, followed by the prevalence rate of 12.8% (5/39) in "green" brick production job and 10% in repairing brick model job description.

Seven cases or 38.8% (7/18) had clinical symptoms included weakness, dyspnea, low fever and chest pain. Eleven percent (2/18) of cases had abnormal physical signs of cyanosis and clubbing fingers. The pulmonary function test among cases was abnormal at proportion of 44.4% (8/18) which 75% (6/8) was restrictive ventilatory defect.

Two of cases were silicotuberculosis. The chest radiographs revealed mostly p and q of shapes and sizes with the parenchymal profusion of 2/2 at 38.9% (7/18).

In the case-control study, the case had worked for 25 years or more at 20.8 times of controls and this was significantly different ($p < 0.05$, OR = 20.8). This was not adjusted for age. The cases and controls were not significantly different

in terms of smoking habits ($p < 0.05$, OR = 0.8).

DISCUSSIONS AND RECOMMENDATIONS

Even two from three studies concerned the occurrence of silicosis among brick workers did not show any cases of silicosis.^{3,4} This study confirmed the existing prevalence of silicosis among brick workers of 9.4% which was rather high. Since the development of silicosis depended upon the material used in the process, thus this study, different from other two, identified silicosis cases among refractory brick along with rather high silica content. As the highest prevalence rate was found among workers preparing raw materials to produce bricks, so the main concentration in providing prevention and control measures should be set for this group of workers first if there is limited budget. The primary prevention for those workers who did not develop the disease should be urgently set up by using engineering control, especially the local hood ventilation.

For two cases of silicotuberculosis were referred for further management in the chest disease hospital.

Cases of definite silicosis (ILO-1980), classification of "p 1/1" and above aged below 50 years and who are symptomatic should preferably not continue in work with silica exposure. All definite silicosis cases must be followed up annually to exclude complications.

REFERENCES

1. Crompton, Graham K.: *Occupational Lung Disease*, pp. 178-184. Oxford: Blackwell Scientific Publication, London (1980).
2. Peters, John M.: *Silicosis*. In: James A. Merchant. *Occupational Respiratory Diseases*. US Government Printing Office, Washington, D.C. (1986).
3. Rajhans, G.S., Budlovsky, J.: Dust Conditions in Brick Plant of Ontario. *Am. Ind. Hyg. Assoc.* 33:256-268 (1972).
4. Keatinge, G.F., Potter, N.M.: Health and Environmental Condition in Brickworks. *Br. J. Ind. Med.* 1:931-944 (1949).
5. Fulton, W.B., Butters, F.E., Dooley, A.E., Koppenhaver, F.B., Matthews, J.L., Kirk, R.M.: *A Study of Silicosis in the Silica Brick Industry*. Commonwealth of Pennsylvania, Department of Health, Bureau of Industrial Hygiene, pp. 60, Harrisburg (1941).
6. Capro, R.O., Morris, A.H., Gardner, R.M.: Reference Spirometric Values Using Techniques and Equipment that Meet ATS Recommendations. *Am. Rev. Respir. Dis.* 123:659-664 (1981).
7. International Labour Office: *Guidelines for the Use of ILO International Classification of Radiographs of Pneumoconioses Revised Edition 1980*. International Labour Office Occupational Safety and Health Office. Geneva (1980).

ACKNOWLEDGEMENTS: The authors would like to acknowledge Dr. Hjordis Foy, Professor at University of Washington, Seattle, and Dr. Nicholas Wright of University of Robert, New Jersey, USA.

PROGRESSIVE MASSIVE FIBROSIS AND THE INFLUENCE OF BODY SHAPE

TIMOTHY J.L. HALEY, Ph.D

8 West Way, Pinner, Middlesex, England (Formerly London School of Hygiene & Tropical Medicine)

ABSTRACT

New evidence is presented of the increasing risk of attack with reduced body weight. Unlike the recently reported case control study by British Coal¹ there is only slight evidence of an association with Body Mass Index. For the first time it has been possible to use logistic regression models to assess the influence of individual-identifying information such as age, height, and weight in analysis of these prospective data. This has been achieved by employing enhanced computational methods to process the multi-punched records of Cochrane.²

Investigation of the cross-sectional data from the twenty-year follow-up of the men of the Rhondda Fach in South Wales³ provides strong evidence of a lower mean weight of those with Progressive Massive Fibrosis (PMF) category A than in those unaffected. These findings were consistent across categories 2 and 3 background Simple Pneumoconiosis and nearly every age-group.

Little support was found for the hypothesis that pulmonary tuberculosis has a role in the development of PMF.

There is clear evidence that higher grades of Simple Pneumoconiosis are strongly associated with an increased probability of developing PMF.



GENERAL VIEW OF THE

MURKIN SERIES

INTRODUCTION

To facilitate study of factors relating to the development of Progressive Massive Fibrosis, in 1950 the Pneumoconiosis Research Unit of the British Medical Research Council initiated a survey of the smaller of the two Rhondda Valleys in mid Wales—the Rhondda Fach.⁴ This total population epidemiological and intervention study was designed to investigate the importance of exogenous tuberculosis infection in the occurrence of PMF. Through extensive hospitalization, the environment was made as tuberculosis-free as possible. The adjacent Aberdare valley was used as an untreated reference.

At the time of initial survey, the eight towns of the Rhondda Fach were grouped around four collieries, which provided employment for most of the men. A view of the valley is given above. The total population was approximately 19,000; pneumoconiosis was commonplace amongst the numerous miners and ex-miners.

RESULTS FROM THE TWENTY-YEAR FOLLOW-UP

All Miners and Ex-miners

Comparison of mean Heights for all men alive at the start of study indicates little difference between radiographic categories 0, 1+2+3, and A+BC. Marked differences exist between the mean Weights of the PMF (A+BC) and SP groups (Figure 1).

Miners and Ex-miners with Category 2, 2A, and 3,3A
The men with PMF category A were sub-divided on the basis

of their background SP category. The youngest age-group was omitted since few of these men have PMF. The oldest age-group was omitted to reduce the confounding influence of advanced age. Mean Weights of men with PMF category A and those of corresponding SP groups free from PMF at the time of the first survey are presented in Figure 2; all groups are large (> 20), except for the oldest 3A's. For nearly every age-group and within each background SP category, the mean Weights for those with category A are much lower than those for men without category A (Figure 2). The between-group differences in mean Height are small.

COMPARATIVE STUDY

As a test of the hypothesis that men who were initially free from Progressive Massive Fibrosis and who subsequently developed it (i.e. were attacked) do not differ appreciably in their physical characteristics from those not attacked, having allowed for their background category of simple pneumoconiosis, the prospective eight-year incidence of PMF in miners and ex-miners of the Rhondda Fach was compared with that of miners in the Aberdare valley.² The radiographs were read in chronological order independent of any other knowledge about the individual; the average of the radiographic categories of simple pneumoconiosis at time of survey and follow-up was used. This is henceforth referred to as "simple pneumoconiosis (SP) category."

The Data

Of the 1853 men originally seen in the surveys, 1226 men had complete data: 581 in the Rhondda Fach, and 645 in the Aberdare valley. A binary indicator of PMF status at time of follow-up was established—not attacked: 0, attacked: 1.

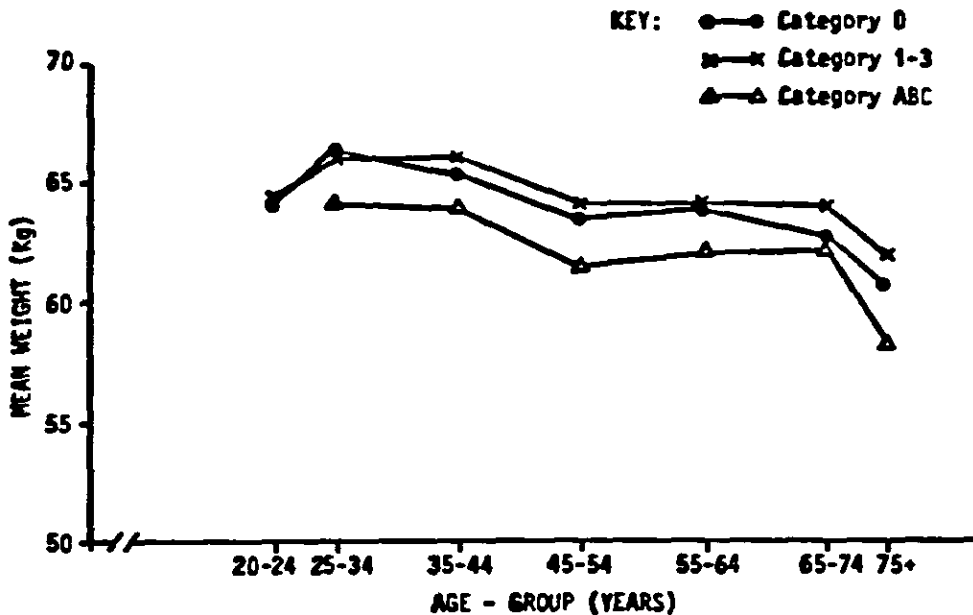

Figure 1. Mean weights by age-group for total initial Rhondda Fach population of miners and ex-miners.

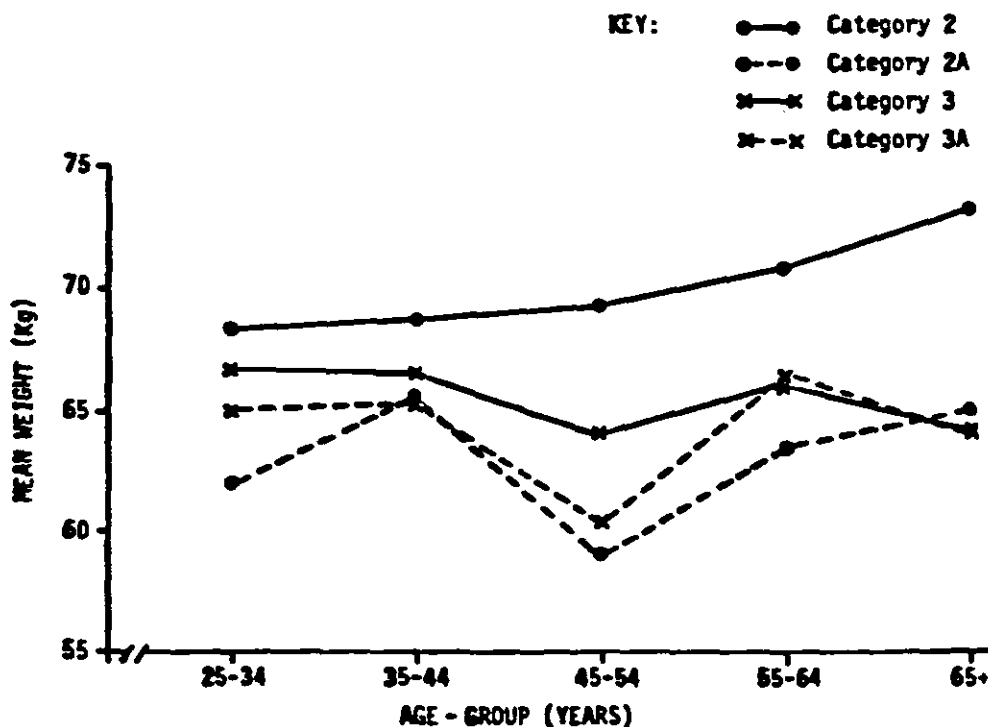

Figure 2. Mean weights by age-group for miners and ex-miners with category A PMF and those without: for background SP categories 2, 3

Simple Pneumoconiosis category was noted on a five-point scale: 1, 1.5, 2, 2.5, 3. The arithmetic mean of chest width at full inspiration and at full expiration was denoted Mean Chest Diameter (MCD). The Body Mass Index ($BMI = \text{Weight}/\text{Height}^2$) of Quetelet,⁶ and the index of Body Type, i.e. $\text{Height}^2/(10 * \text{MCD})$ due to Rees and Eysenck⁷ were calculated. Age at time of survey was grouped: 1 = 25-34, 2 = 35-44, 3 = 45-54, 4 = 55-64, 5 = 65+ years.

Preliminary Results

Table I displays the summary description of these data. The percentage and number attacked for each Valley, together with the number at risk, are shown in Table II.

Due to the similarity of corresponding cell entries for Weight and BMI amongst those attacked and those not attacked for each valley, tables were combined across the Valleys. Those attacked have consistently lower mean Weight than those who did not develop PMF (Table III); little such difference is found for the Body Mass Indices (Table IV).

Tabulation of percentage attacked by Age-group and Grouped Weight for SP category 2.5 suggested that the group of men weighing 60-69 Kg are at particular risk of attack by PMF. However, interpretation poses problems since there are a large number of cells which are either empty or are based on small numbers.

Logistic Regression Analysis

To further investigate the role of anthropometric indices in the probability of attack by PMF, logistic linear models were used to analyse the data.⁸ The outcome variable being a binary indicator of attack by PMF, regression coefficients with a positive sign indicate variables associated with increased probability of attack, and conversely for a negative sign. Variables Age, SP category, and Valley were included as factors (dummy variables).

Model development. A variety of models were fitted in the development of a parsimonious model that adequately described the data. Models were compared by referring the change in Deviance, as terms are added or removed, to tables of Chi-squared. The Deviances do not have an "absolute" meaning, only differences between them may be safely treated as Chi-squared variables.⁹ The importance of individual regressors was considered both in terms of the size of their contribution to the regression equation and their standard Normal Deviate (SND).

To provide a baseline for assessing subsequent models, a null model (ϕ) containing only the Grand Mean (%GM) was fitted.

Main effect and first order interaction terms were added to form model I. The regression estimates for these and the other models fitted are summarized in Table V.

Table I
PMF Attack Study: Ranges, Means and
Standard Deviations of Explanatory Variables

VARIABLE	V A L L E Y			
	Rhondda Fach	Aberdare	Rhondda Fach & Aberdare	
	Mean (SD)	Mean (SD)	Range	Mean (SD)
Valley	0	1	0 - 1	0.526
Proportion Attacked	0.189	0.127	-	0.157
SP category	2.419 (0.445)	1.869 (0.652)	1 - 3	2.130 (0.627)
Age group	2.336 (1.089)	2.385 (1.033)	1 - 5	2.362 (1.060)
Height (M)	1.679 (0.061)	1.679 (0.067)	1.29 - 1.94	1.679 (0.064)
Weight (Kg)	65.06 (8.94)	64.03 (9.16)	44.40 - 107.0	64.52 (9.07)
Body Mass Index	23.07 (2.87)	22.68 (2.66)	16.73 - 44.42	22.87 (2.76)
Mean Chest Diameter (cm)	27.30 (2.09)	27.40 (2.00)	20.0 - 38.5	27.35 (2.05)
Body Type	103.8 (9.2)	103.4 (9.2)	61.63 - 141.12	103.56 (9.20)

During model development, it was clear that SP terms were dominant, with their regression coefficients increasing monotonically with increasing category of SP. The contributions made by the Age terms were small and non-significant. There appeared to be little contribution made by the Valley term, either directly or through associated interaction terms.

Little evidence was found to reject the null hypothesis of a true value of zero for the coefficients for MCD, Body Type, or BMI (QI). Coefficients for Height, though consistently negative suggesting reduced probability of attack amongst taller men never attained anywhere near a conventional level of significance ($P > 0.2$). The contribution made by the Weight term was consistently negative, with generally strong evidence to reject the null hypothesis of a true value of zero. Thus indicating reduced probability of attack amongst heavier men.

Additional support for inclusion of the Weight term was provided by further models which omitted this term (VIII), included a Height term (IX), or replaced the Weight term by the BMI (X). The results from model IX indicated a true effect of Weight rather than an effect of overall 'size'. Little

improvement in fit resulted from the adoption of any of these models.

Many other models were assessed. In particular, SP. Weight interaction terms were included but none of these models showed any useful improvement in fit.

Predictive Value of Model VII

Using the inverse logistic transform and three categories of Weight: Low (50 Kg), Medium (65 Kg), and High (80 Kg), the percentage probabilities of a miner being attacked by PMF were evaluated as a function of SP category. The estimates are shown in Table VI.

Table VII was formed by applying these predicted percentage attacks to the numbers at risk.

Although changes in Deviance indicate that the explanatory ability of the model VII incorporating Weight and SP is much greater than that of model VII using SP alone, further investigations indicate that the main contribution of Weight to the predictive ability of the model is due to its smoothing-out of perturbations in the predicted numbers corresponding to SP category 2. Simple pneumoconiosis is the dominant factor in the attack process.

Table II
Percentage and Number Attacked by PMF, and Number at Risk
for Each Valley by Age-group and SP Category

Age Group	Rhondda Fach					Aberdare					Total				
	Category of Simple		Pneumoconiosis			Category of Simple		Pneumoconiosis			Category of Simple		Pneumoconiosis		
	1	1.5	2	2.5	3	1	1.5	2	2.5	3	1	1.5	2	2.5	3
20 - 34	-	(0.0)	14.6	13.5	29.3	0.0	4.5	9.1	19.4	35.3	0.0	3.9	12.2	15.7	31.0
	0	0	6	7	12	0	2	3	6	6	0	2	9	13	15
	0	7	41	52	41	12	44	33	31	17	12	51	74	83	58
35 - 44	-	(0.0)	13.2	15.4	30.2	0.0	11.0	18.0	5.9	35.3	0.0	11.3	25.4	19.7	43.7
	0	0	9	12	19	0	8	9	2	12	0	8	18	14	31
	0	6	68	78	63	46	73	50	34	34	46	79	118	112	97
45 - 54	-	(0.0)	17.8	21.7	24.4	0.0	7.7	3.2	26.9	43.5	0.0	6.5	11.8	23.6	31.3
	0	0	8	10	10	0	4	1	7	10	0	4	9	17	20
	0	9	45	46	41	39	52	31	26	23	39	61	76	72	64
55 - 64	-	(0.0)	17.9	38.5	16.7	0.0	5.6	20.0	45.5	(11.1)	0.0	4.5	18.8	41.7	14.3
	0	0	5	5	2	0	1	4	5	1	0	1	9	10	3
	0	4	28	13	12	27	18	20	11	9	27	22	48	24	21
65 +	-	(0.0)	26.7	(9.0)	(25.0)	(9.0)	(20.0)	(0.0)	(20.0)	(0.0)	(9.0)	(12.5)	23.5	10.0	(20.0)
	0	0	4	0	1	0	1	0	1	0	0	1	4	1	1
	0	3	15	5	4	2	5	2	5	1	2	8	17	10	5

where () indicates percentage based on number at risk < 10.

Table III
Weights (Kg) of Men—Combined Valleys

SP Category	Total Group	Not attacked		Attacked		No. at Risk
	Mean (SD) Range	No.	Mean	No.	Mean	
1	64.94 (10.02) 46.70 - 97.10	126	64.94	0	-	126
1.5	64.32 (9.46) 45.80 - 107.00	205	64.44	16	62.84	221
2	64.93 (9.35) 47.20 - 98.40	284	65.06	49	64.53	333
2.5	64.76 (9.14) 44.40 - 106.10	246	65.50	55	61.47	301
3	63.55 (7.59) 46.70 - 87.10	172	64.09	73	62.26	245

Linear regression analyses for men attacked by PMF provide some slight evidence of a trend of decreasing average Weight with increasing average category of SP. By contrast, the evidence for the Body Mass Index is somewhat stronger.

DISCUSSION

Strong evidence of the importance of weight in the aetiology of PMF category A is provided by the cross-sectional data shown in Figures 1, 2. However, by their very nature, it is not possible to make inferences about the prognostic value of SP or Weight in determining the probability of a man being attacked by PMF.

There is a strong influence of SP category on the probability of attack by PMF throughout all the models considered. The (independent) influence of reduced Weight on the probability of attack is also obvious. There was however no evidence of B relation between probability of attack and Age. This is similar to the finding of Cochrane.² The logitatic regression analyses provide strong evidence of increasing risk of attack with reduced weight. There is only slight evidence of an influence of the Body Mass Index.

The consistent but slight trend of decreasing Weight (BMI) with increasing Lung Dust content as found in the final regression analyses supports the idea that lighter men are preferen-

tially selected for attack.

Model VII provided the best parsimonious description of the data; it was able to predict well the number of men attacked.

In terms of the hypothesis of Cochrane et al⁴ that pulmonary tuberculosis has a role in the development of PMF, the consistently small and non-significant coefficient for Valley and the corresponding terms for interaction with SP suggest little support for this idea. Cochrane² noted that despite the efforts of the field experiment, there may have been no real difference in the level infection in the two valleys. However, his further work comparing the attack rate during different periods following the initial survey was regarded as undermining the 'tuberculosis hypothesis'.

CONCLUSION

Further study of the prognostic value of these indices, in particularly weight, would be useful. In view of the great variability of the attack rate of PMF in different coal-fields, consideration of datasets based on other types (ranks) of coal would be informative.

If the importance of weight as a predictive factor in attack by PMF can be validated, the use of a weight-monitoring procedure might lead to further improvements in the health of miners.

Table IV
Body Mass Indices of Men—Combined Valleys

SP Category	Total Group	Not attacked		Attacked		No. at Risk
	Mean (SD) Range	No.	Mean	No.	Mean	
1	23.26 (3.00) 17.80 - 34.39	126	23.26	0	-	126
1.5	22.80 (2.86) 17.37 - 36.60	205	22.85	16	22.23	221
2	23.01 (2.89) 17.32 - 33.86	284	23.00	49	23.05	333
2.5	22.91 (2.89) 16.73 - 44.42	246	22.94	55	22.80	301
3	22.48 (2.11) 17.88 - 30.32	172	22.68	73	22.02	245

Table V
Summary of Models

Regression coefficient
Standard error
SND

Model	Grand Mean	Wt(1)(?)	Age(2)	Age(3)	Age(4)	Age(5)	Step's Discriminant category				Height	Weight	Chest Diameter	Body Type	Quotient Index	Wt(2)		Wt(2)		SND	
							1.5	2	2.5	3						SP = 1.5	SP = 2	SP = 2.5	Wright		Wright
0	-1.670 0.07830																			1660 on 1225 df	
I	-0.676 5.111	-0.3822 0.517	0.1750 0.2100	0.09000 0.2610	0.2297 0.3045	0.1736 0.0711	0.2350 0.097	1.152 3.070	7.322 3.070	7.003 3.009	-1.916 2.057	-0.02055 0.01700	0.007734 0.05274			5.968 0.019	-0.5044 0.4392	-0.1760 0.4274	0.0131 3.074	-0.008233 0.02440	959.6 on 1260 df
II	-0.319 0.023	0.3293 0.2906	0.00021 0.2177	0.0011 0.2354	0.3402 0.2904	0.2325 0.0622	0.3020 0.031	7.200 3.020	7.012 3.026	7.003 3.011				-73.02 09.70		5.052 0.161	-0.0231 0.4355	-0.2012 0.4263			958.3 on 1212 df
III	-0.300 4.571	0.2636 0.2929					0.2267 0.920	7.195 3.073	7.300 3.073	7.000 3.004	-1.001 1.511	-0.02190 0.04430	0.004100 0.05261			5.026 0.056	-0.5061 0.4372	-0.1035 0.4262			960.3 on 1214 df
IV	-0.830 0.070	0.3022 0.2913					0.2565 0.025	7.200 3.910	7.110 3.910	7.073 3.001			-0.05014 0.04957	-0.01002 0.03790		5.002 0.146	-0.0021 0.4355	-0.1006 0.4264			957.4 on 1215 df
V	-0.042 3.030	0.2500 0.2123					0.2157 0.940	7.177 3.070	7.200 3.070	7.037 3.070	-0.02910 0.01015					5.072 0.071	-0.5790 0.4305	-0.1054 0.4240			961.0 on 1216 df
VI	-0.756 3.920	0.00100 0.1777					5.990 3.071	6.045 3.067	7.105 3.067	7.724 3.067		-0.02932 0.01009									966.3 on 1219 df
VII	-0.644 3.913						5.970 3.070	6.757 3.064	7.053 3.064	7.070 3.063		-0.02900 0.01005									968.5 on 1220 df
VIII	-0.566 3.916						6.015 3.020	6.000 3.010	7.000 3.010	7.700 3.010											977.0 on 1221 df
IX	-0.040 4.420						5.999 3.063	6.015 3.057	7.072 3.057	7.690 3.057	-1.055 1.509	-0.02900 0.01171									967.0 on 1218 df
X	-7.496 3.972						5.990 3.912	6.700 3.906	7.000 3.906	7.074 3.906					-0.06613 0.03232						975.7 on 1220 df

Table VI
The Percentage Probability of Attack Using Model VII

Category of SP	Category of Weight			% Predicted on Overall Weight
	Low	Medium	High	
1	0.03	0.02	0.01	0.02
1.5	10.4	6.9	4.5	7.2
2	20.8	14.4	9.7	14.7
2.5	25.3	17.8	12.2	18.3
3	38.6	28.7	20.5	29.8

Table VII
The Number of Attacks Predicted by Model VII

Category of SP	Number of men at risk	Number of attacks	
		Observed	Predicted
1	126	0	0.024
1.5	221	16	15.991
2	331	49	49.006
2.5	301	55	55.000
3	245	73	73.002

REFERENCES

- Hurley, J.F., Maclaren, W., Alexander, W.P., Cowie, A.J., Collins, H.P.R., Ewing, A., Hazledine, D.J., Jacobsen, M., Muro, L., Soutar, C.A.: *Factors influencing the occurrence of progressive massive fibrosis in British coalminers*. Report No. TM/84/2, Institute of Occupational Medicine, Edinburgh (1984).
- Cochrane, A.L.: The attack rate of progressive massive fibrosis. *Br. J. Ind. Med.* 19:52-64 (1962).
- Cochrane, A.L., Haley, T.J.L., Moore, F, Hole, D.: The mortality of men in the Rhondda Fach 1950 - 1970. *Br. J. Ind. Med.* 36:15-22 (1979).
- Cochrane, A.L., Cox, J.G., Jarman, T.F.: Pulmonary tuberculosis in the Rhondda Fach. *Br. Med. J.* October 18, ii:843-852 (1952).
- Haley, T.J.L.: Migration, Selection, and Mortality: a Population study of the men of the Rhondda Fach. Ph.D dissertation. University of London (1987).
- Quetelet, A.: *Sur l'Homme et le developpement de ses facultes ou Essai de Physique Sociale*. Bachelier, Paris (1835).
- Rees, W.L, Eysenck, H.J.: A factorial study of some morphological and psychological aspects of human constitution. *J Ment Sci*, January, XCI,382:8-21 (1945).
- Baker, R.J., Nelder, J.A.: *General linear interactive modelling (GLIM)*. Release 3. Numerical Algorithms Group, Oxford. (1978).
- Swan, A.V.: Fitting linear models by maximum likelihood methods to grouped and ungrouped binomial data. *GLIM newsletter No.11*. Numerical Algorithms Group: Oxford (1985).

This paper is based on work submitted for the Ph.D. degree of the University of London.⁵

SUGGESTIONS FOR REVISION OF THE ILO CRITERIA FOR ABESTOSIS BASED ON SCREENING 10,000 WORKERS

KAYE H. KILBURN,* M.D. • Raphael H. Warshaw,† B.A.

*University of Southern California, School of Medicine, Environmental Sciences Laboratory,
2025 Zonal Avenue, HMR 913, Los Angeles, California 90033, USA

†Worker's Disease Detection Services, Inc., 441 West Allen Avenue, Suite 114,
San Dimas, California 91773

ABSTRACT

In a screening program from 1985-87, 4,572 American shipyard and construction workers were present and were questioned about abnormalities while posteroanterior (PA) and lateral chest radiographs were interpreted for asbestosis using ILO International Classification of Radiographs of Pneumoconiosis 1980. Technically, unsatisfactory PA films were of 3 types: 1) underexposed due usually to body build or obesity, 2) overexposed due to body build or loss of lung substance due to cigarette smoking (CS) and 3) underinflated with diaphragms above the 9th intercostal space. A repeat PA film was needed in 7% of workers to have 99% films of technical quality 1. The profusion of irregular opacities in underexposed and/or underinflated films may appear to be 1/0 while ideal films on the same subject are 0/0 or 0/1. Overexposed films because of reduced lung parenchyma in smokers may be read as 0/0 when they are 1/0 or 1/1. Irregular opacities should be defined as: 1) distinct from vascular shadows and breast shadows, frequently accompanied by septal lines and present in 2 or more zones. Obliteration of one costophrenic angle with diffuse thickening is a frequent sequelae of pleural effusions from asbestosis which occur in 1-2% of subjects. Pleural fibrosis may subsequently extend into lung. Otherwise, unilateral pleural disease is often due to trauma, pleurisy, fractured ribs or infection with effusion.

INTRODUCTION

The ILO classification for chest radiographs¹ has provided a thoughtful and rational method for quantifying pneumoconiosis. Some critics are disturbed by its success which has broadened its purpose, which is to provide internationally agreed criteria for description of radiographs for epidemiological studies. Clearly it has been adopted for clinical diagnosis of asbestosis, coalworkers pneumoconiosis and silicosis in individual patients, for epidemiological studies of occupationally exposed and bystander populations,² hospitalized patients³ and for compensation and litigation. Inter observer variation remains a problem. Intra observer variation has been steadily reduced. Some users have by oversight or deliberately misinterpreted the scale by leaving out the diagnostic boundary of 1/0 profusion of irregular opacities for asbestosis.⁴ Others fault the classification for less than perfect correlation with pathology particularly the microscopic recognition of fibrosis.⁵ On the whole, its defenders exceed its critics although no one would argue seriously that it could not be improved.

With improvements in mind 30 scientists convened in mid May in Athens to share concerns about the approaching decade birthday of the 1980 revision of a classification scheme which originated in 1916. The workshop was sponsored by the Collegium Ramazzini, an international organization, which is dedicated to the observational and descriptive principles of

Bernardo Ramazzini, the father of occupational health. Irving J. Selikoff of Mount Sinai Medical School in New York, President of the Collegium, convened the meeting and described the evolution of a classification for the major dust diseases: asbestosis, coalworkers pneumoconiosis and silicosis. The initial classification, developed about 1916, was adopted by the First International Conference of Experts on Pneumoconiosis in Johannesburg under ILO auspices. It was perfected at the 3rd International Conference in Sidney in 1950. The so-called Geneva classification was adopted there in 1958 with revisions and additions made in 1968. In 1971 the UICC scheme was integrated with the ILO. The 1980 ILO revision provided a new set of 22 standard radiographs selected as mid-category profusion of small opacities to facilitate the classification of radiographs for epidemiology and disease progress.

METHODS AND RESULTS

Currently over 21.5% of workers screened for asbestosis are categorized as 1/0 or 1/1, only 5.1% are 1/2 or greater while 73.4% are negative, Table I. Because the critical border is 0/1 to 1/0 major effort was directed at obtaining ideal films, minimizing confounding by over or under exposure and competing shadows contributed by breast, pectoral girdle muscle and fat is important. Under inflation of lungs so that diaphragms are not below the 9th intercostal space can contribute

Table I
Frequency of Asbestosis (ILO Profusion Categories) in 4572
Boilermakers and Pipefitters in the United States 1986-1988

ILO :	Freq.	Percent	Cum. %	AGE	LATENCY
0/0 :	2956	64.65	64.65	50.8 ± 11.9	25.4 ± 10.9
0/1 :	399	8.73	73.38	56.6 ± 10.5	29.3 ± 11.2
1/0 :	487	10.65	84.03	59.4 ± 9.8	30.9 ± 10.2
1/1 :	498	10.89	94.93	61.8 ± 9.4	32.9 ± 9.4
1/2 :	94	2.06	96.98	63.5 ± 9.9	33.1 ± 9.9
2/1 :	53	1.16	98.14	65.9 ± 10.7	31.1 ± 12.5
2/2 :	61	1.33	99.48	66.3 ± 9.5	34.6 ± 11.0
2/3 :	14	0.31	99.78	64.7 ± 12.4	28.9 ± 12.1
3/1 :	4	0.09	99.87	59.0 ± 3.5	33.3 ± 12.1
3/2 :	3	0.07	99.93	66.7 ± 13.3	30.0 ± 7.9
3/3 :	3	0.07	100.00	67.0 ± 16.0	30.7 ± 15.0
	4572	100.00		mean 54.1 ± 12.2	mean 27.5 ± 11.1

to a spurious impression 1/0. Such hypo-inflation occurs in 12% of PA radiographs unless technicians instruct subjects to breathe out and take in their "absolutely biggest possible breath." When such instructions are insisted upon only 2.1% of radiographs have diaphragms not below the 9th intercostal space.

DISCUSSION

The instructions for readers should be improved to reduce ambiguity and more emphasis should be given to production of new standard chest radiographs which are of film quality 1, ideal for ILO interpretation rather than marginal films. There are serious questions as to whether films below quality 1 should or even can be interpreted? It may be best to make the decision as to pneumoconiosis the summary, not as it is now, the readers initial decision. Can a single radiograph be considered adequate for detecting and quantifying pleural as well as parenchymal asbestosis. Adding a lateral chest radiograph would contribute dorsal and ventral pleural mapping, survey the area behind the heart and assist in classifying emphysema (see below) by showing the anteroposterior slope of the diaphragms, at a small increase in cost. Optional density of chest structures especially the lung fields and full inflation of the lungs as judged by diaphragm descent to at least below the right 9th intercostal space are essential.

How can the precision of the basic decision between a positive and negative radiograph, especially for asbestosis, the 0/1 1/0 decision be improved. The concrete addition to this decision

making would be employment of "boundry films," films which define the division between steps of classification. It would be a testable strategy. A detailed protocol for developing a set of single or paired radiographs on both sides of boundry (0, 1, 2 and 3) has been described for the classification by Michael Jacobson of Edinburgh's Institute of Occupational Medicine. This would add 3 or 6 films to the standard 18 which define the mid categories. "The hypothesis is that it would be easier to classify films within categories that are defined by lower and upper limits of profusion of small opacities, than it is to match appearances defined as typical of a particular category." Ideal boundry films would represent an even 50:50 split of interpretation on both sides by a large number of experienced readers. The practicality of this strategy could be tested by determining if it reduced inter-reader variability, intra-reader variability and correlated with dust exposure.

Dr. G.K. Shuis-Cramer (South Africa) has questioned whether the size of opacities in asbestosis s/s vs s/t or t/t predict population differences for non radiograph measures particularly for pulmonary function. If not, is it important to record size? There is a further question as to whether large irregular opacities, u/u, are ever seen in asbestosis.

Considerable discussion concerned the asbestos pleural dilemma. Would more detailed and comprehensive description be useful in the ILO reading or is the 3 fold separation into diffuse pleural, plaques and calcification sufficient. Clearly analysis using the present scale vs an experimental extended

scale of one or two large populations correlating pulmonary functional impairment, clinical findings and these pleural changes would answer this question. At least two large cohorts of asbestos exposed workers have been studied in the United States by Selikoff (New York) and by Kilburn (Los Angeles) which could be analyzed to answer such questions. Perhaps of greatest importance is whether to include obliteration of both costophrenic angles plus diffuse thickening as a most advanced pleural category. Should diffuse pleural thickening be divided into upper, mid and lower zones plus costophrenic angles? Further research on large collected cohorts of asbestos exposed workers as proposed would answer this question as well as establishing the predictive value of pleural asbestos disease. The ILO classification has already been employed to describe the radiologic progression of asbestosis.⁶ Similarly it should be quite simple to settle the film quality issue: as to which quality produces unacceptable variability in interpretation and thus determine whether films below quality 1 can be interpreted without unreasonable variability.

The listing of nonpneumoconiotic observations, the "other disease" category, is useful but needs updating to incorporate current findings. Perhaps an intuitive or logical organization would help rather than the present alphabetical array. In addition to bullae and definite emphysema, step wise incremental emphysema criteria to include low flat diaphragms on PA film, low flat diaphragms on the lateral film, wide (beyond 2.5 cm) retrosternal clear zone, and radiolucency or hypovascular zones⁷ which has already been field tested in cotton textile workers with byssinosis are suggested.⁸ Other useful additions would include 1) dilated aorta, 2) surgical clips, 3) staples and sutures, and 4) bronchiectasis. Calcified primary complex could be added to tuberculosis.

Technical advances such as computerized tomography greatly increase the cost of radiographic diagnosis with a modest yield

epidemiologically. Nevertheless high resolution (extended scale) CT scans may be well justified in individual cases, for example, in differentiating pseudotumors or linear pleuro-parenchymal infiltrations. Even computerized interpretation should be explored because it has the potential to eliminate intra-reader and inter-reader variability.

Research should be directed to expand the range and or test the predictive capacity of the ILO classification for chest X-rays. Time will help sort out these needs. We need to consider ways to extend the usefulness of this venerable classification scheme. It is time to examine the issues which need to be faced before 1991, the proposed revision date.

REFERENCES

1. International Labour Office. Guidelines For The Uses Of ILO International Classification Of Radiographs Of Pneumoconioses. *Occupational Safety and Health Series*, Geneva, No 22:1-48, 1980.
2. Kilburn, K.H., Lilis, R., Anderson, H.A., Miller, A., Warshaw, R. Interaction of asbestos, age, and cigarette smoking in producing radiographic evidence of diffuse pulmonary fibrosis. *Amer. J. Med.* 80:377-81, 1986.
3. Epstein, D.M., Miller, W.T., Bresnitz, E.A., Levine, M.S., Gefter, W.B.: Application of ILO classification to a population without industrial exposure: findings to be differentiated from pneumoconiosis. *AJR* 142:53-58, 1984.
4. Murphy, R.L., Becklake, M.R., Brooks, S.M. et al. The diagnosis of nonmalignant diseases related to asbestos. *Amer. Rev. Respir. Dis.* 134:363-368, 1986.
5. Rockoff, S.D., Schwartz, A.: Roentgenographic underestimation of early asbestosis by international labor organization classification: analysis of data and probabilities. *Chest* 93:1088-91 1987.
6. Suoranta, H., Huuskonen, M., Zitting, A., Juntunen, J.: Radiographic Progression of Asbestosis. *Amer. J. Indus. Med.* 3:67-74, 1982.
7. Sutinen, S., Christoforidis, A.J., Klugh, G.A., Pratt, P.C.: Roentgenologic criteria for the recognition of nonsymptomatic pulmonary emphysema. *Amer. Rev. Resp. Dis.* 91:69-76, 1965.
8. Kilburn, K.H.: Byssinosis. *Amer. J. Indus. Med.* 2:81-88, 1981.

PULMONARY FUNCTIONAL IMPAIRMENT FROM YEARS OF ARC WELDING

KAYE H. KILBURN,* M.D. • Raphael H. Warshaw,† B.A.

*University of Southern California, School of Medicine, Environmental Sciences Laboratory, 2025 Zonal Avenue, HMR 913, Los Angeles, California 90033, USA

†Worker's Disease Detection Services, Inc., 441 West Allen Avenue, Suite 114, San Dimas, California 91773 USA

ABSTRACT

Construction welders without shipyard exposure had vital capacity and flows measured by spirometry, chest radiographs classified for asbestosis using ILO criteria and were administered an occupational and respiratory questionnaire. Data on workers with asbestosis (ILO profusion 1/0 or greater) was deleted from analysis. The 226 men without asbestosis were 45 years old, 69.2 inches tall and had welded for 21.3 years (means). Expressed as mean percent predicted after adjusting for height, age and years of smoking mean FVC was 101%, FEV₁ was 98.7%, FEF₂₅₋₇₅ was 94.0%, FEF₇₅₋₈₅ was 91.8% and TGV was 104.2%. The 43 nonsmokers had similar reductions in flows. The regression coefficient for years of welding for FVC was -.0031, for FEV₁ was -.0035, for midflow (FEF₂₅₋₇₅) was -.0080, all significant ($p < 0.05$), and for FEF₇₅₋₈₅ was -.0056 not significant. Calculated from regression equations 40 years of welding would reduce FVC to 95.2%, FEV₁ to 92.2%, midflow to 79.2% and flow at low lung volume to 81.3%. Chronic exposure to welding gases and fumes reduces flows in small airways in welders without asbestosis or shipyard exposures.

INTRODUCTION

Metal welding generates ozone, nitrogen oxides and metal oxide aerosols which cause respiratory tract irritation, cough and excessive phlegm and impair pulmonary function in welders.¹ Arc welders in shipyards have reductions in vital capacity and FEV₁²⁻⁶ which have been considered permanent. Because many studies were done when 80 to 90% of the welders were also cigarette smokers, the degree of interdependence of effects of welding exposure and smoking is unclear. It follows that the chronic functional impairment in those welders who had never smoked is also poorly defined. Also earlier studies ignored the effects of asbestosis on pulmonary function.^{7,8} Thus, this study of 226 welders, 43 of whom had never smoked, explored the chronic effects of welding on pulmonary function and interactions with cigarette smoking. We examined 226 welders, employed largely at construction sites and power plants, who had never worked in shipyards and had no evidence of asbestosis on chest radiographs. Pulmonary functions were expressed as percentage of predicted based on individual comparisons corrected for height, age and for cigarette smoking⁹ to assess the contribution to impairment of years of welding.

METHODS

226 male welders from two midwestern locals of the International Brotherhood of Boilermakers, Iron Shipbuilders, Blacksmiths, Forgers and Helpers were studied during 1987 for asbestosis by questionnaires for occupational exposures and respiratory disease and for symptoms, a chest physical

examination, posteroanterior and lateral chest radiographs and pulmonary function measurements. Informed consent was obtained after the nature of all procedures was fully explained to each welder. The questionnaire was adapted from DLD-78¹⁰ as used in the study of the Michigan population¹¹ and inquired about chronic bronchitis, asthma, wheezing and shortness of breath as well as past respiratory and cardiovascular disease symptoms and illnesses. It was administered by trained interviewers. The mobility of welders doing construction jobs, variation in composition of base metal and rod, type of welding, and the uniqueness of each site for their lifetime made exposure measurement impossible. As an exposure surrogate, years of welding was used in analyses.

Spirometry was measured on Saturday or Sunday, at least 16 hours after a workshift on Ohio Rolling Seal spirometers which were repeatedly calibrated during the study with a 3 L syringe. Spirometry was repeated until 2 agreed within 5% with subjects standing, wearing a noseclip, and followed American Thoracic Society¹² criteria including that the origin of FEV, was established by back extrapolation. The best curve was digitized and FVC, FEV₁, FEF₂₅₋₇₅, and FEF₇₅₋₈₅ and for each individual value as percentage predicted was adjusted for height, age and years of cigarette smoking. Values were compared to the Michigan male population sample in smoking specific groups.⁹ Posteroanterior and lateral chest radiographs were made at full inflation. They were examined for evidence of asbestosis of lung or pleura using ILO classification criteria.¹³ The 65 welders with signs of asbestosis of the 291 originally studied

were not analyzed further.

Statistical testing was performed in a Hewlett-Packard 9816 computer using the Hewlett-Packard library of statistical programs including calculation of confidence intervals, regression analysis and equation development. Analysis of variance using an SAS statistical program in an IBM computer was used to compare function values for caucasian male welders to the entire sample of Michigan men, not just those selected as normals for modelling pulmonary function.⁹ What this means is that we restored to the group used for modelling "normal" predictive pulmonary function all subjects who had been excluded because of clinical abnormalities. Thus, the comparison group included all adult males studied in Michigan. A P value of < 0.05 was used to demonstrate significance.

RESULTS

The 226 electric arc welders were 45.0 years old, and 175.8 cm. tall (mean values) and they had welded an average of 21.3 years, Table I. Only 19.0% had never smoked cigarettes. Nearly 20% had chronic bronchitis diagnosed by phlegm production for 3 months per year for at least two years and 11.3% had a history of asthma. Nonsmokers prevalence of chronic bronchitis was 23% and of asthma was 13%; thus they were as symptomatic as smokers for these disorders. Pulmonary functions for the 226 men are presented as group means and percentages of predicted, adjusted for effects of height, age and for years of cigarette smoking,⁹ Table I. There were no years of smoking adjustment for FVC, for FEV₁ it was -0.0094 for years of smoking for log FEF₂₅₋₇₅ it was -0.0052 years of smoking and for log FEF₇₅₋₈₅ it was 0.0112 years of smoking. The mean vital capacity of the group was 101.0%, FEV₁ was 98.7%, FEF₂₅₋₇₅ was 94.0%, FEF₇₅₋₈₅ was 91.8% and TGV was 104.2%. Although nonsmokers had slightly better function than the whole group, after adjustment for smoking only the difference in FEF₇₅₋₈₅ was statistically significant, Table I.

To test for chronic effects of welding the critical analysis was to correlate years of welding, as the independent variable with the percentage of predicted values for FVC, FEV₁, FEF₂₅₋₇₅, and FEF₇₅₋₈₅, as dependent variables by regression analysis, Table II. This was done after each individual observation of pulmonary function was adjusted for height, age and for years of cigarette smoking. For the 226 welders the regression coefficients for years welding were -0.0031 for FVC, Figure 1a; -0.0035 for FEV₁, Figure 1b; -0.0080 for FEF₂₅₋₇₅, Figure 1c; and -0.0058 for FEF₇₅₋₈₅, Figure 1d. All were significant (P < 0.05) except for FEF₇₅₋₈₅. Calculating the effects of 40 years of welding on percent predicted using the regression equations for all welders reduced FVC to 95.2%, FEV₁ to 92.2%, FEF₂₅₋₇₅ to 79.2% and FEF₇₅₋₈₅ to 81.3%, Table II. The 43 nonsmokers had larger regression coefficients for years of welding on mid and terminal flows. Thus for FEF₂₅₋₇₅ the regression coefficient was -.0095 and it was -.0171 for FEF₇₅₋₈₅. Both were significant (P < 0.05). The smaller coefficients for FVC of -.0013 and for FEV₁ of -.0036 were not significant. (Figure 2) Thus, in nonsmokers the significant effects of duration of welding were limited to small airways. Perhaps the implications of these relationships for subjects who weld but have

never smoked are best shown by calculation of the reduction in function expected from 40 years of welding using regression equations. Thus without exposure to cigarette smoke 40 years of welding would not reduce vital capacity but FEV₁ would fall to 93.3% of predicted. Midflow would fall to 77.6% of predicted and terminal flow would drop to 62.0%.

DISCUSSION

Chronic exposure to arc welding gases and fumes reduced flows including FEV₁. Such airway obstruction moderately impairs function of welders after 20 to 40 years. Cigarette smoking welders showed additional adverse effects which exceed standard adjustments for duration of smoking.⁹ Thus, welders who smoked showed more than the sum of functional impairments from welding and from cigarette smoking. Initially, welding fumes and gases reduce flows in small airways as seen unequivocally in the 43 nonsmokers. When cigarette smoking is added vital capacity and FEV₁ are also reduced to an extent beyond the standard adjustment for smoking. If the effects of the cigarette smoke and welding smoke aerosols were equal and additive then 40 years of welding alone would resemble 20 years of welding in cigarette smokers. That the 40 year calculated effect of welding alone is to reduce flows including FEV₁ but not to reduce FVC suggests that the effects of welding and cigarette smoking are similar. Predictive regression equations for pulmonary function in these welders account stepwise for height, age and duration of cigarette smoking (years) by multiple linear regression, and isolate the effect of welding exposure. Horizontal lines would reflect decrements from occupational exposure to welding. These men all had some exposure to asbestos in insulating materials, gloves and blankets. Excluding those with signs of pulmonary asbestosis is a major step in removing its effects and goes beyond earlier studies of welders²⁻⁶ but does not guarantee the absence of subtle effects.⁷

The additional decrement which occurred in smokers appears to be best explained by the synergism between the effects of particles, gases and chemicals adsorbed on particles in two complex aerosols.¹⁴ One, cigarette smoke, is an exceedingly complex mixture of tobacco distillates and combustion products characterized as particles of complex hydrocarbons or tar containing over 2,500 chemical species and a mixture of gases including carbon monoxide, nitrogen oxides and aldehydes.¹⁵ Welding fumes are oxides of metals with additives from flux, rod coating and surface treatments and gases, largely ozone and nitrogen oxides.¹⁶ The particles from both cigarette combustion¹⁷ and the welding arc¹⁸ are poorly digestible by pulmonary macrophages, damage lining cells of distal airways and connective tissue during phagocytosis and disposal.¹⁸ Thus, cigarette smoke, and welding of asbestos produce goblet cell metaplasia and mucous obstruction¹⁹ in distal terminal bronchioles.⁷ This is followed by peribronchiolar cuffs of cells and fibroblast proliferation, collagen production, and scarring with luminal narrowing and obstruction of terminal and respiratory bronchioles.^{19,20,21} Functional loss of small airways by anatomic obstruction and obliteration removes respiratory units from ventilation and eventually reduces vital capacity. Although one might speculate that the welding particles would also stimulate digestion of lung at the alveolar level to destroy alveolar walls

Table I
 Pulmonary Functions, Means (m), Standard Deviations (sd), and Percentage Predicted
 in 226 Midwestern Welders without Evidence of Asbestosis

	ALL WELDERS		NONSMOKING WELDERS	
	m	sd	m	sd
Number	226		43	
Age - years	45.0 ± 10.4		44.9 ± 10.7	
Ht - cm.	175.8 ± 6.5		175.5 ± 8.9	
Welding years	21.3 ± 10.0		20.5 ± 10.4	
Smoking years	21.3 ± 13.9		0	
Cig/day	25.1 ± 18.9		0	
Asbestos exp. yrs.	22.6 ± 10.8		19.9 ± 9.8	
Ch. Bronchitis %	19.9		23.3	
Asthma history %	11.3		13.2	
FVC L.	4.93 ± .87		5.03 ± .89	
% pred.	101.0 ± 14.6		103.9 ± 15.6	
FEV ₁ L.	3.77 ± .82		3.98 ± .79	
% pred.	98.7 ± 16.6		100.4 ± 15.8	
FEF ₂₅₋₇₅ L/sec.	3.20 ± 1.37		3.58 ± 1.28	
% pred.	94.0 ± 34.3		96.2 ± 28.3	
FEF ₇₅₋₈₅ L/sec.	0.84 ± .52		1.07 ± .61 *	
% pred.	91.8 ± 46.7		95.6 ± 45.3	
TGV	7.60 ± 1.05		7.19 ± 1.10	
% pred.	104.2 ± 14.8		101.1 ± 15.9	

* P < 0.05

Table II
Correlations, R² and Coefficients from Regression Analysis of Effects of Years of Welding on
Pulmonary Function as Percent Predicted of 226 Midwestern Construction Welders

Percent Predicted	ALL WELDERS			NEVER SMOKED		
	Correlation	r ₂	Regression Coefficient	Correlations	r ₂	Regression Coefficient
Number	226			43		
FVC	-.2096	.0439	-.0031 *	-.0841	.0071	-.0013
FEV ₁	-.2114	.0447	-.0035 *	-.2351	.0553	-.0036
FEF ₂₅₋₇₅	-.2326	.0541	-.0080 *	-.3479	.1211	-.0095 *
FEF ₇₅₋₈₅	-.1182	.0140	-.0056	-.3929	.1544	-.0171 *

* P<0.05

Percent pred. FVC = 107.50 - .0031 x (40) years welding = 95.2

Percent pred. FEV₁ = 106.25 - .0035 x (40) years welding = 92.2

Percent pred. FEF₂₅₋₇₅ = 111.20 - .0080 x (40) years welding = 79.2

Percent pred. FEF₇₅₋₈₅ = 103.68 - .0056 x (40) years welding = 81.3

Figure 1a-1d. Regression equations for all welders and effect of 40 years of welding on percentage predicted.

Percent pred. FVC = 106.44 - .0013 x (40) years welding = 101.4

Percent pred. FEV₁ = 107.74 - .0036 x (40) years welding = 93.3

Percent pred. FEF₂₅₋₇₅ = 115.57 - .0095 x (40) years welding = 77.6

Percent pred. FEF₇₅₋₈₅ = 130.63 - .0171 x (40) years welding = 62.0

Figure 2. Regression equations for non-smoking welders and effect of 40 years of welding on percentage predicted.

and increase total lung capacity as does cigarette smoke, the welders have no significant increase in total lung capacity after adjusting for the effects of cigarette smoking.²²

Earlier studies of the effects of welding were of cigarette smoking shipyard welders who are frequently exposed, in addition to asbestos in insulating materials, to silica from sand blasting, paint fumes, metal particles, and other toxins in closed spaces of hulls or compartments. In shipyard welders Hunnicutt in 1968² anticipated the smoking-welders synergism by showing that smokers but not nonsmokers had reduced peak flow, FEV₁ and FEF₂₅₋₇₅. In another study the shipyard effect was amply underscored by finding that 61 shipyard welders and 63 shipyard pipefitters had reduced FVC, FEV₁, TLC, RV and DLCO compared to "new pipefitters" and to current standard populations.³ In engineering shop welders in Finland only diffusing capacity was reduced,⁴ again emphasizing the shipyard effect. After lumping ex-smokers and nonsmokers, a Swedish shipyard study showed welders had significantly lower FEV₁, FVC and TLC than nonwelders.⁵ A Newcastle, Great Britain shipyard study of 209 welders and 109 controls matched 2:1 for age, height, smoking habits, residence and social class showed that in both smokers and nonsmokers FVC and FEV₁ were significantly lower than in controls and DLCO was significantly lower in nonsmokers.⁶ The most comparable study to this one found significant reductions of FVC, FEV₁, FEF₂₅₋₈₅ and DLCO in 72 nonsmoking shipyard welders.²³

This study has eliminated confounding exposures from work in shipyards,⁸ ruled out asbestosis recognized by irregular opacities on chest radiographs and adjusted for the expected effects of years of cigarette smoking. Thus, for the first time arc welding gases and fumes can confidently be regarded as causing airway obstruction. However, the magnitude of decrements is smaller than that from cigarette smoke alone⁹ or from asbestosis.⁸ Welding fumes and gases, especially particles to which are adsorbed cytotoxic molecules, appear to elicit cellular and tissue reactions which narrow and distort small airways. Studies of lung pathology in welders or experimental studies of chronic exposure are needed to elicit the mechanisms.

REFERENCES

1. Kilburn, K.H.: Respiratory functional impairment in metal welders: An interpretation of current data in Health Hazards and Biological Effects of Welding Fumes and Gases. R.M. Stern., A. Berlin., A.C. Fletcher., J. Jarvisalo., Eds. Excerpta in Medica, International Congress Series, New York 676:363-378 (1986).

2. Hunnicutt, T.N. Jr., Cracovener, D.J., Myles, J.T.: Spirometric measurements in welders. *Arch. Environ. Health* 8:661-669 (1964).
3. Peters, J.M., Murphy, R.L.H., Ferris, B.G., Burgess, W.A., Ranadive, M.V., Pendergrass, H.P.: Pulmonary function in shipyard welders: An epidemiologic study. *Arch. Environ. Health* 26:28-31 (1973).
4. Antti-Poika, M., Hassi, Pyy, L.: Respiratory disease in arc welders. *Int. Arch. Occup. Environ. Health* 40:225-230 (1977).
5. Oxhøj, H., Bake, B., Wedel, H., Wilhelmsen, L.: Effects of electric arc welding on ventilatory lung function. *Arch. Environ. Health* 34:211-217 (1979).
6. Akbarhanzadeh, F.: Long-term effects of welding fumes upon respiratory symptoms and pulmonary function. *J.O.M.* 22:337-341 (1980).
7. Kilburn, K.H., Warshaw, R.H., Einstein, K., Bernstein, J.: Airway disease in non smoking asbestos workers. *Arch. Environ. Health* 40:293-295 (1985).
8. Kilburn, K.H., Warshaw, R., Thornton, J.C.: Asbestos diseases and pulmonary symptoms and signs in shipyard workers and their families in Los Angeles. *Arch. Intern. Med.* 146:2213-2220 (1986).
9. Miller, A., Thornton, J.C., Warshaw, R., Bernstein, J., Selikoff, J., Teirstein, A.S.: Mean and instantaneous expiratory flows, FVC, and FEV₁: Prediction equations from a probability sample of Michigan, a large industrial state. *Bull. Eur. Physiopathol. Resp.* 22:589-597 (1986).
10. Ferris, B.G. Jr.: Epidemiology standardization project. *Am. Rev. Resp. Dis.* 118:7-54 (1978).
11. Selikoff, L.J., Anderson, H.A.: A survey of the general population of Michigan for health effects of polybrominated biphenyl exposure. Report to Michigan Department of Public Health. Environmental Sciences Laboratory, Mount Sinai School of Medicine of City University, New York. (Sept. 30, 1979).
12. ATS Statement: Snowbird workshop on standardization of spirometry. *Am. Rev. Resp. Dis.* 119:831-838 (1979).
13. International Labour Office: U/C International classification of radiographs of pneumoconiosis in occupational safety and health series. Geneva, International Labour Office, (1980).
14. Kilburn, K.H.: Particles causing lung disease. *Environ. Health Perspectives* 55:97-109 (1984).
15. Stedman, R.L.: The chemical composition of tobacco and tobacco smoke. *Chem. Rev.* 68:153-207 (1968).
16. Ulfvarson, U.: Survey of air contaminants from welding. *Scand. J. Work. Environ. Health* 7:(Suppl 2):1-28 (1981).
17. Kilburn, K.H., McKenzie, W.: Leukocyte recruitment to airways by cigarette smoke and particle phase in contrast to cytotoxicity of vapor. *Science* 189:634-637 (1975).
18. Stern, R.M., Figott, G.H., Abraham, J.L.: Fibrogenic potential of welding fumes. *J. Appl. Toxicol.* 3:18-30 (1983).
19. Karpick, R.J., Pratt, P.E., Asmundsson, T., Kilburn, K.H.: Pathological findings in respiratory failure: goblet cell metaplasia, alveolar damage and myocardial infarction. *Ann. Internal. Med.* 72:189-197 (1970).
20. Gloyne, S.R.: The morbid anatomy and histology of asbestosis. *Tubercule* 14:550-558 (1933).
21. Churg, A., Wright, J.L., Wiggs, B., Pare, P.D., Lazar, N.: Small airways disease and mineral dust exposure. *Am. Rev. Res. Dis.* 131:139-143 (1985).
22. Kilburn, K.H., Warshaw, R.H., Thornton, J.C., Miller, A.: Total lung capacity in American welders and shipyard workers. (In preparation).
23. Kilburn, K.H., Warshaw, R., Boylen, C.T., Thornton, J.C.: Respiratory symptoms and functional impairment from acute (cross-shift) exposure to welding gases and fumes. (Submitted to Chest, 1988.)

COAL RANK AND DURATION OF EXPOSURE AS DETERMINANTS OF TOXICITY IN INHALATION EXPERIMENTS WITH RATS

P. SEBASTIEN • H. Daniel • A. Wastiaux • M. Le Meur

Centre d'Etudes et Recherches de Charbonnages de France
Verneuil en Halatte, France

ABSTRACT

In a first series of experiments, four ranks of coal were tested by exposing the animals during 6 months to 300 mg/m³ of respirable dust. In all dusts the quartz content was below 0.5% and the mineral matter content below 17%. Groups of animals were killed 6, 12 and 18 months after the start of the experiment. Independently of the coal rank, it was observed in the lung: a) a high dust retention (100 mg in average per rat) with undetectable clearance, b) an increase in lung weight progressing after the exposure period, c) a five times increase in lipids content, d) a slight production of collagen, e) no histological signs of fibrosis but alveolar aggregation of dust-laden macrophages.

In order to document the importance of exposure duration, similar experiments were then carried out with one of the four types of coal, animals being exposed for 2, 4 and 6 months. The pulmonary dust retention, the rate of lung weight progression and the collagen production were all positively related to exposure.

In these inhalation experiments, the pulmonary reaction to coal dust was essentially characterized by an inflammatory reaction leading to an increase in lung weight. It was related to the duration of exposure but not to the coal rank.

No Paper provided.

ALUMINUM-INDUCED LUNG DISEASE

P. DE VUYST • P. Dumortier • L. Schandene • J. C. Yernault

Chest Service, Erasme University Hospital
Brussels, Belgium

ABSTRACT

Different lung diseases were diagnosed in two patients exposed to aluminum dusts: a severe lung fibrosis (61 year old patient) and a granulomatosis (32 year old patient).

In both cases, large amounts of respirable Al particles were present in BAL and lung tissue, and Al was identified within the lesions. In the second case, sarcoid-like aspect of granulomas, T-helper lymphocyte alveolitis and positive transformation test of lymphocytes with Al compounds suggest that in some patients, Al dust can induce an immune granulomatosis similar to berylliosis.

Since pulmonary disease due to aluminum is very uncommon even in heavily exposed workers, host response seems to be a factor in its development. Further observations will be necessary to confirm if aluminum-induced granulomatosis can evolve towards lung fibrosis.

BAL appears to be useful in this type of problem for detecting retention of aluminum particles and cellular abnormalities, and for the recovery of lymphocytes for immunological studies. Moreover, it could serve as a monitoring tool after eviction and/or treatment.

No Paper provided.

PLANNING A DUST FREE COAL MINE

ROGER F. J. ADAM

R.A. SYSTEMS, Pittsburgh, PA, USA

ABSTRACT

Silica and coal dust have been responsible for the death of more miners than all other mining hazards together. Progress in dust control has been made but, still today, air ventilating many underground coal mines is too dusty to be really safe for the unexposed miners!

Some new techniques such as water jet cutting, foam generation, air scrubbing, and remote control, will still bring some progress. However, achieving a dust free mine requires recognizing respirable dust as the main concern at the stage of mine design and planning. Water being the common mean to fight dust, any coal moisture limitation should be eliminated from the working face to the power plant including the preparation plant. Replacing belt conveyors by an hydraulic transport is the optimum solution. Slurry density control and regulation by an expert system make this solution technically and economically feasible. Hydraulic transport will permit to maximize the efficiency of all dust control techniques using water.

Progress in dust control in underground coal mines has been made but, still today, air of many mines is too dusty. The amount of 2 mg of respirable coal dust per m³ of air, considered as dangerous, represents only half of a millionth of the coal produced if one considers 1,000 tons per shift in a face with a ventilation of 8 m³/s (13,000 cfm). As demonstrated by the experience of the last forty years, dust control is a problem which will probably never be solved while using current mining methods.

It is time to design and develop economically competitive dust free mines.

Dust sources are many, and their contribution to miners dust exposure may be very different from one mine to another. Among these sources of respirable dust, coal cutting, coal handling, coal transport, roof caving and roof drilling for bolting are the main sources. If we take the example of longwall mining, Figures 1 and 2 illustrate dust concentration distributions measured in longwall faces with the position of the exposed miners.

Three basic approaches are used to reduce the exposure of miners to respirable dust:

- Reduce the respirable dust production.
- Suppress the airborne dust produced.
- Keep the miners in areas of lower dust concentration.

The last approach, helped by the development of remotely controlled equipment is efficient for one dust source only and should be used as the last resource.

It appears that water is the common mean to fight dust: water injection in the solid coal, water sprays on the cutting drums, water sprays at each coal transfer point. . . . That results in a major problem because mines are designed to handle and produce coal with a limited moisture content for either

technical or commercial reasons. In the mine itself, the main limitation comes from the belt transport system but, outside it may come from the cleaning plant or from the power plant. In the U.S. the coal preparation plants are, by chance, equipped with wet screening, but it is worth mentioning that dry screening in a cleaning plant limits the moisture content of the "run of mine" coal at a 6% level and prevents a good dust control in the mine.

Today, a dust free mine is a real possibility but achieving this goal requires, first of all, to recognize respirable dust as a top priority at the mine planning and design stage. Trying to control respirable dust in mines not adequately designed is almost impossible.

Taking this novel approach, several mining methods can be selected and appropriate equipment developed.

DUST SOURCES AND CONTROL

We saw from Figures 1 and 2 that, in a longwall face there are three dust sources of almost equal importance: coal cutting and loading, roof caving, belt conveyor and transfer points. In room and pillar mining there is generally no roof caving but roof bolting may be a main source of respirable dust.

We will briefly review for each dust source, promising development and techniques already tested, such as water jet cutting, foam generation, hydraulic transport, which could eliminate dust sources and be combined to obtain a global approach to the development of a dust free mining method, but, also could be used individually to improve dust control in existing mines.

Coal Cutting

Coal cutting is the first dust source. As shown on Figure 3

each bit is crushing coal in very fine dust at its top. The major steps to reduce this source of dust were:

- The development of "wet drums" where water sprays are located on the cutting drum itself;
- The use of a small number of larger bits allowing to fit each bit with a water spray;
- Water injection in the solid coal ahead of the face.

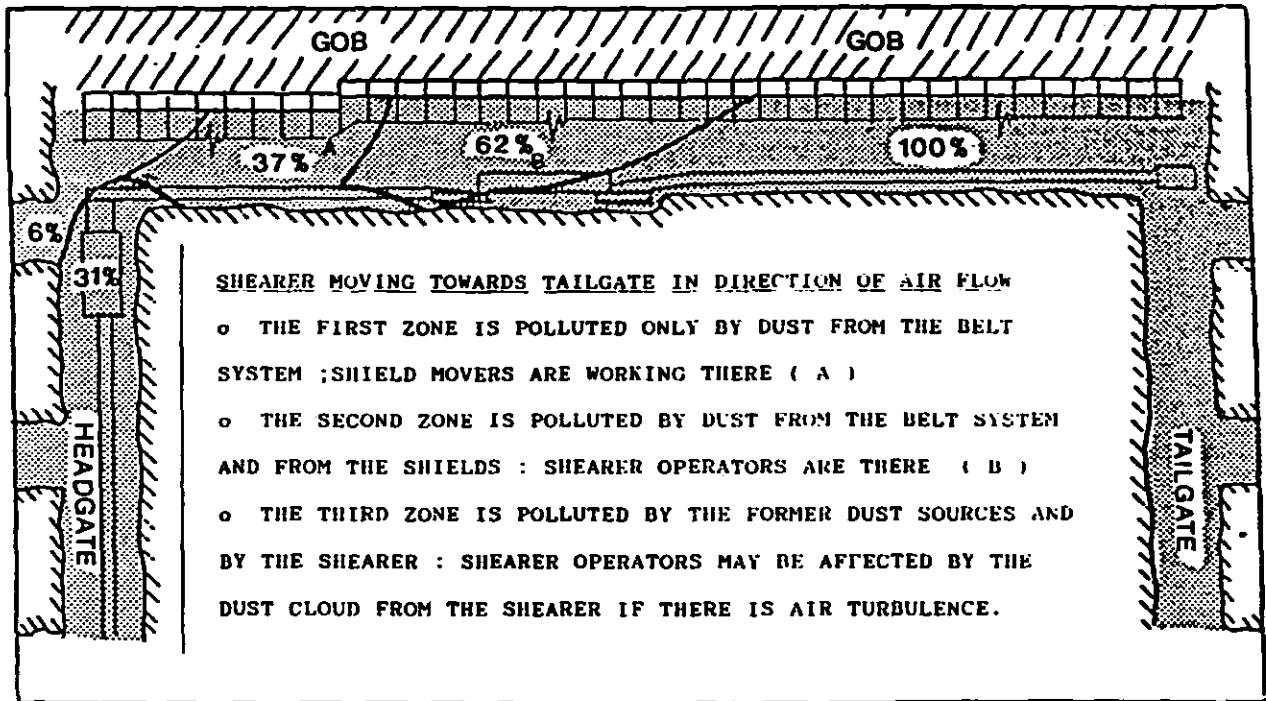

Figure 1. Longwall dust source contribution of total dust make for head-to-tail passes.

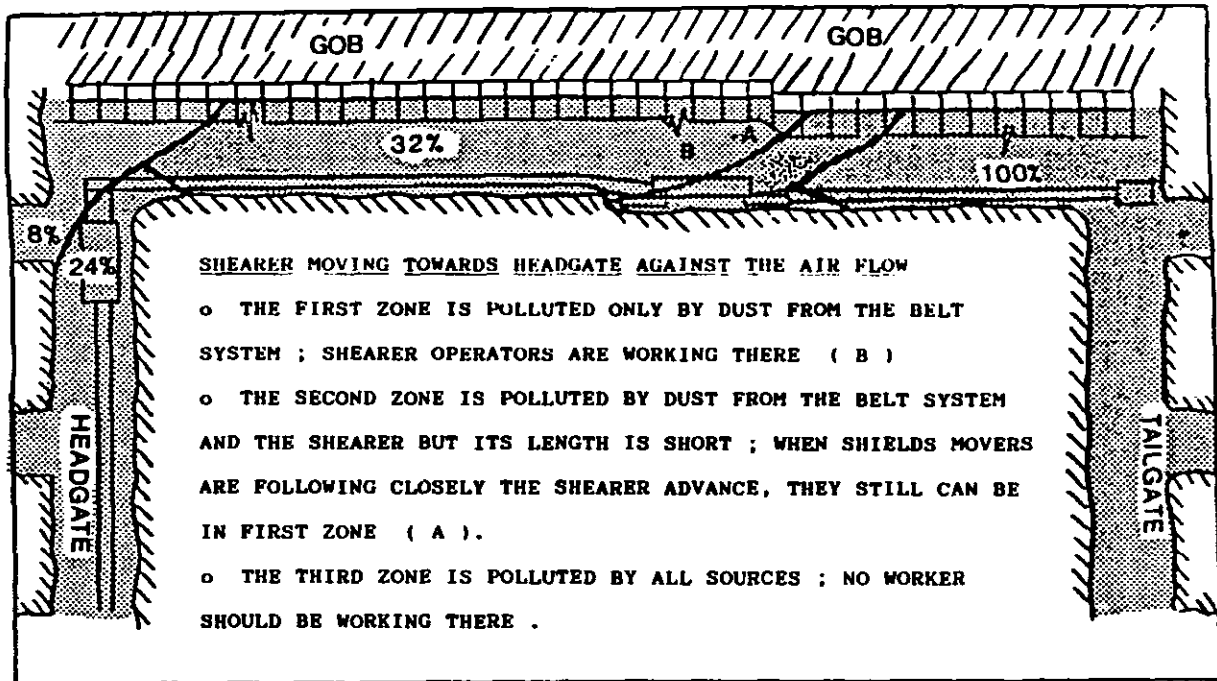
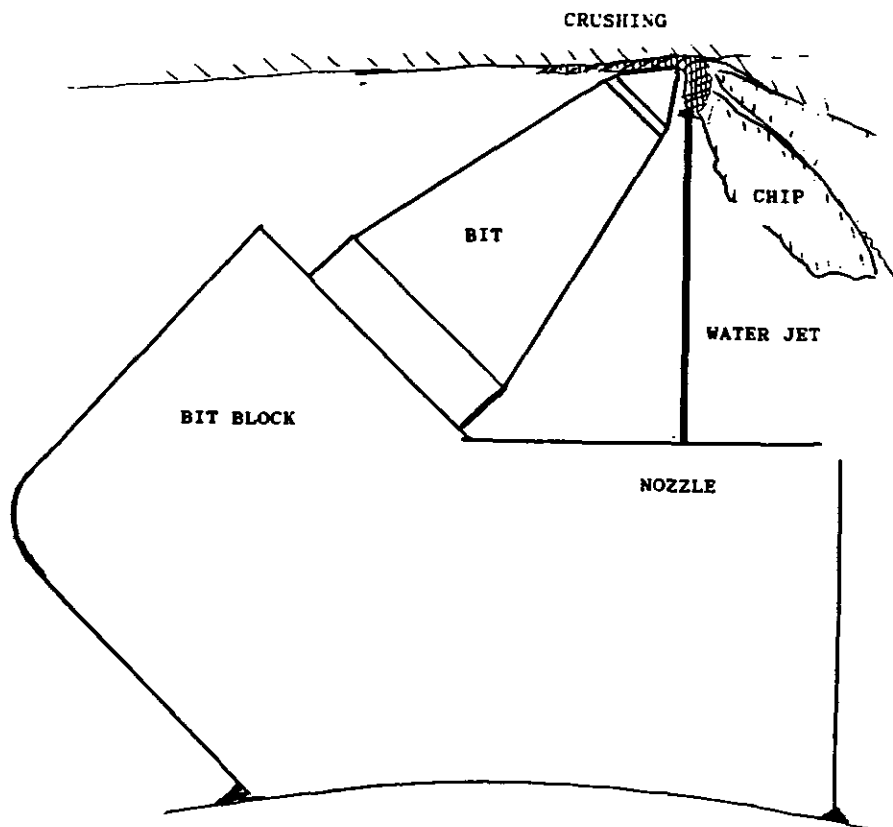

Figure 2. Longwall dust source contribution of total dust make for tail-to-head passes.



CUTTING ACTION OF A CONICAL BIT

THERE IS A CRUSHED AREA AT THE BIT TOP WHICH IS ASSUMED TO BE THE MAIN SOURCE OF DUST FROM CUTTING OPERATION. A HIGH PRESSURE WATER JET AS REPRESENTED IN FRONT OF THE BIT WAS FOUND VERY EFFICIENT FOR DUST ABATMENT .

Figure 3. Cutting action of a conical bit.

The next step will probably be:

- Water jet assist cutting; a jet of high pressure water is directed at the source of dust, the tip of the bit. Surface and underground tests showed a 75% reduction of the dust produced without exceeding a 3000 psi water pressure.¹ The development was retarded by technological problems but at least three projects are ongoing;
- A joint research by Eickhoff and the U.S. Bureau of Mines using high pressure rotating seal and phasing system to supply the HP water to the bits;²
- Two solutions to intensify the water pressure in the cutting head to avoid HP rotating seal and phasing system. One of them developed by R.A. Systems, Figure 4, with the support of Pennsylvania Energy Development Authority allows retrofitting existing machines with new cutting drums.³ The other one⁴ is proposed by Minnovation (G.B.).

Water jet assisting cutting is a solution to decrease dust production while using a small amount of water and could be used on shearers in longwall as well as on continuous miners in room and pillars sections.

Coal Handling and Transport

In addition to the dust generated by mechanical cutting each time coal falls by itself from the face or is mechanically loaded, coal breakage produces dust unless coal is very wet. To avoid using a large amount of water, water infusion ahead of the face is the most efficient way to reduce dust production during coal loading with an added moisture of about 3% only.⁵ The same apply for coal transport: unless coal is very wet, transport on belt conveyor generates dust at least at each transfer point. Dust generation is due to secondary breakage but also to the air drying the coal transported. From the dust control point of view, belt transport is not a good solution. It is a major source of pollution of the air intake and it is obviously very difficult to reduce the exposure to sources polluting the air intake.

DRUM WITH WATER PRESSURE INTENSIFIER

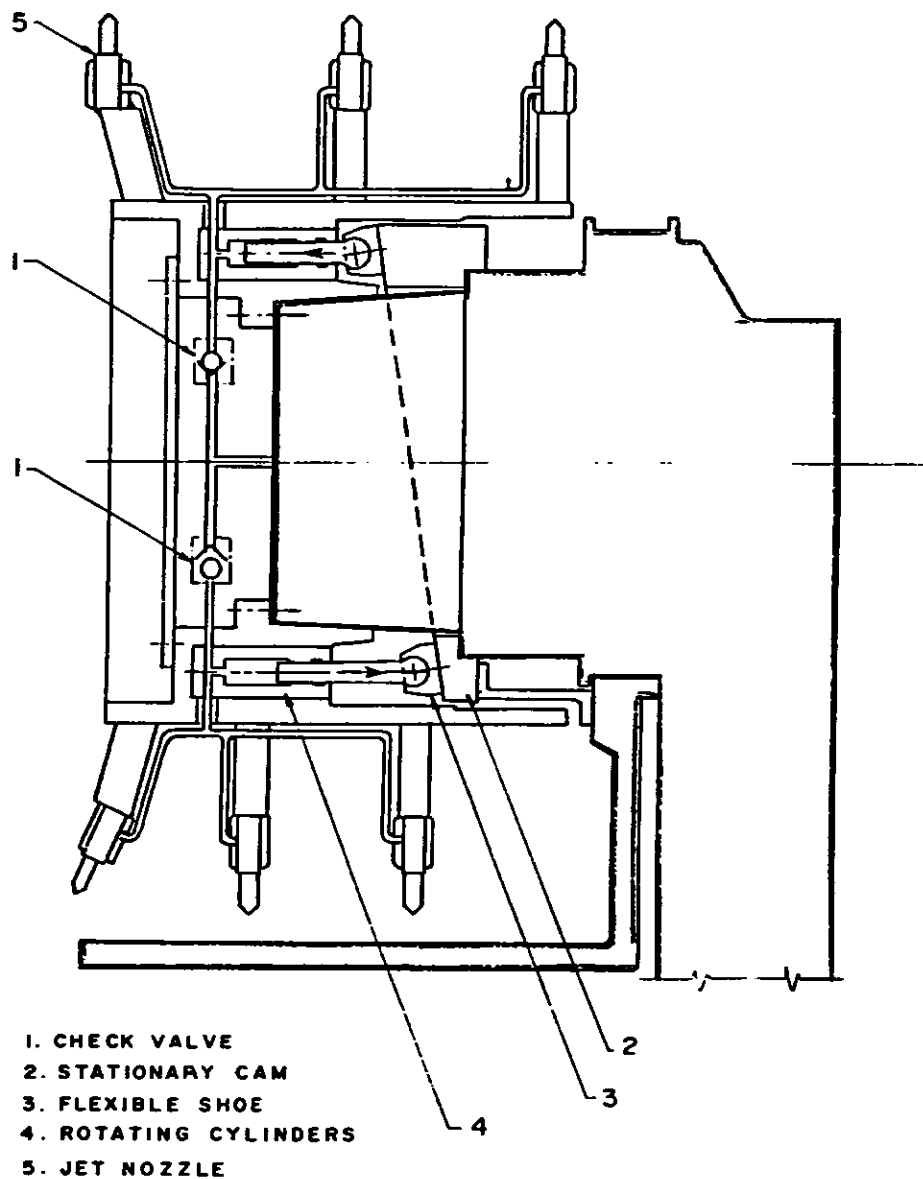

Figure 4. Cutting drum with water pressure intensifier to retrofit shearers with water jet assisted cutting

In planning a dust free mine, there is no doubt that no belt conveyor should be used; they should be replaced by hydraulic transport for two main reasons:

- Hydraulic transport can economically replace the usual belt system and suppress a major respirable dust source.
- It will eliminate the limits a belt conveyor system imposes on the amount of water used for dust control during cutting and loading operations. It is also suitable for hydraulic mining. We do not have to detail the advantages of hydraulic transport. So much has already been said and published on the subject.⁶ The replacement of

belt conveyors by hydraulic pipelines will have an impact on the mine design by elimination of neutral entries. It would alleviate the regulatory problem in the use of a two entries system. It will also improve mine safety by suppressing the risks of mine fire associated with belt conveyors. However, these numerous studies and the mentioned advantages had little result on the development of hydraulic transport in underground coal mines. Only Consolidation Coal Company conducted underground testing.⁶

We should examine why, currently, hydraulic transport is not used more often for handling coal.

- A problem results from the discontinuity of the coal production (even by "continuous" miners) compared to the continuity requirements of a hydraulic transport network.
- Another problem is the ever-recurring change of length of the pipeline branches during mine operations.
- More important is the need for a good control of the slurry density not only to improve the system efficiency but essentially to prevent plugging pipelines.

Existing mine equipment can be modified to provide a steady flow of product to be injected immediately in a pipeline. The transformation can proceed step by step.

In a first phase, storage capability could help matching current equipment with hydraulic transport. As an example, in a room and pillar section, a continuous miner with water jet cutting and no limit of coal moisture could still load in shuttle cars but, at the transfer point, an increased storage capacity could provide a steady flow of coal in the pipeline. A good control of slurry density and automatic adjustment of the flow with a simple expert system will do the rest. In a longwall method the flow of coal is more steady compared to the case where a continuous miner stops producing every five feet for bolting and moving from one entry to another. Injecting coal in a pipeline was studied by Foster Miller and Ingersoll Rand under Government Contracts. Consolidation Coal Company used a crusher/pump vehicle for direct loading behind a continuous miner.^{6,7}

The problem of pipeline extension can be solved, or at least made easier, by using a flexible pipeline similar to the prototype developed and tested by Consolidation Coal company to be attached to a continuous miner to follow it.⁶ Only one flexible section per branch will be required as shown on the conceptual design on Figure 6.

Another important point is the need for a control system of the hydraulic network. Density control is the key point to prevent any risk of plugging the pipelines and also to keep an optimum solid concentration. If the slurry density is accurately measured at each loading point, it is simple to establish an algorithm to regulate all the network using pumps with variable speed drives.⁸

Roof Caving and Shield Support

Shield support brought progress in longwall roof control, but improvements in safety and productivity were paid by an increase of respirable dust generated when the shields are advanced, compared to other types of powdered roof support. Tentative solutions were better designs of the seal between shields and water sprays on the gob side; still the dust production remains important. Two approaches are possible; if it is the only dust source at the face, the exposure to this source could be avoided by keeping all miners upstream. If not, we suggest testing foam generation behind the shields instead of using only water sprays.

Roof Bolting

Most of the roofbolters used in the U.S. mines are drilling with aspiration and filtration of the dust. It was shown that careful maintenance of the dust collection system could take care of the dust problem.⁹ Still a better approach should be wet drilling with or without water jet cutting. In low seams, water jet cutting requires a flexible drill because use of rod extension is not possible. R.A. SYSTEMS is developing such a flexible drill which could also allow prebolting¹⁰ (Figure 5).

Economic Considerations

Some of the proposed solutions such as water jet assist cutting are inexpensive to implement: a shearer or a continuous miner could be retrofitted with water jet assist cutting by changing the drums and using drums with a pressure intensifier which will cost only twice the price of a normal drum. The expense, about five percent of the machine cost, will lower operating costs by increasing bit life and production. Foam generation on shields can be done by using the existing water spray system with no expenses but dust measurements for efficiency control and parameters selection. However, hydraulic transport is a different problem because it will not only result in essential changes of the mine design and in a high moisture content of the run of mine coal, but will also require an important investment in special equipment and appropriate training of all personnel. There is little experience on running an extensive hydraulic network transporting a coarse slurry, with varying factors from the

PREBOLTING WITH FLEXIBLE DRILL AND WATER JET CUTTING

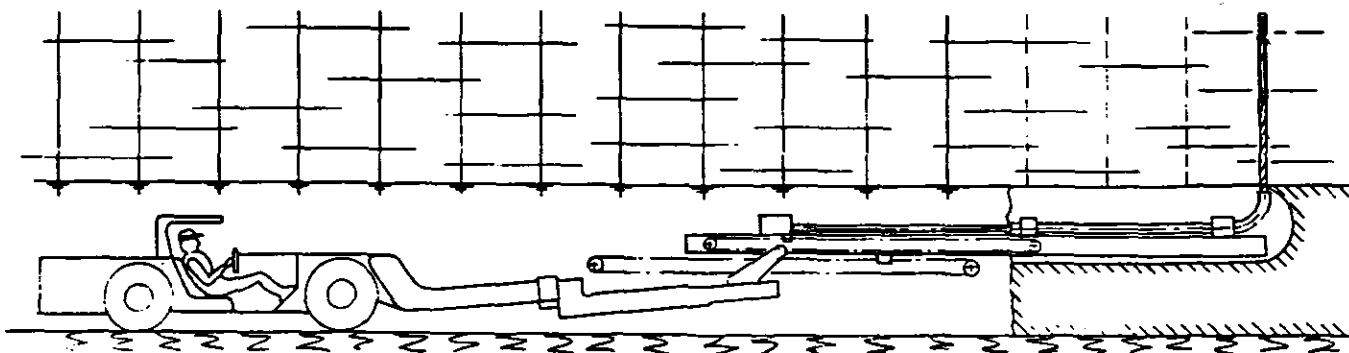

Figure 5. Roof prebolting concept.

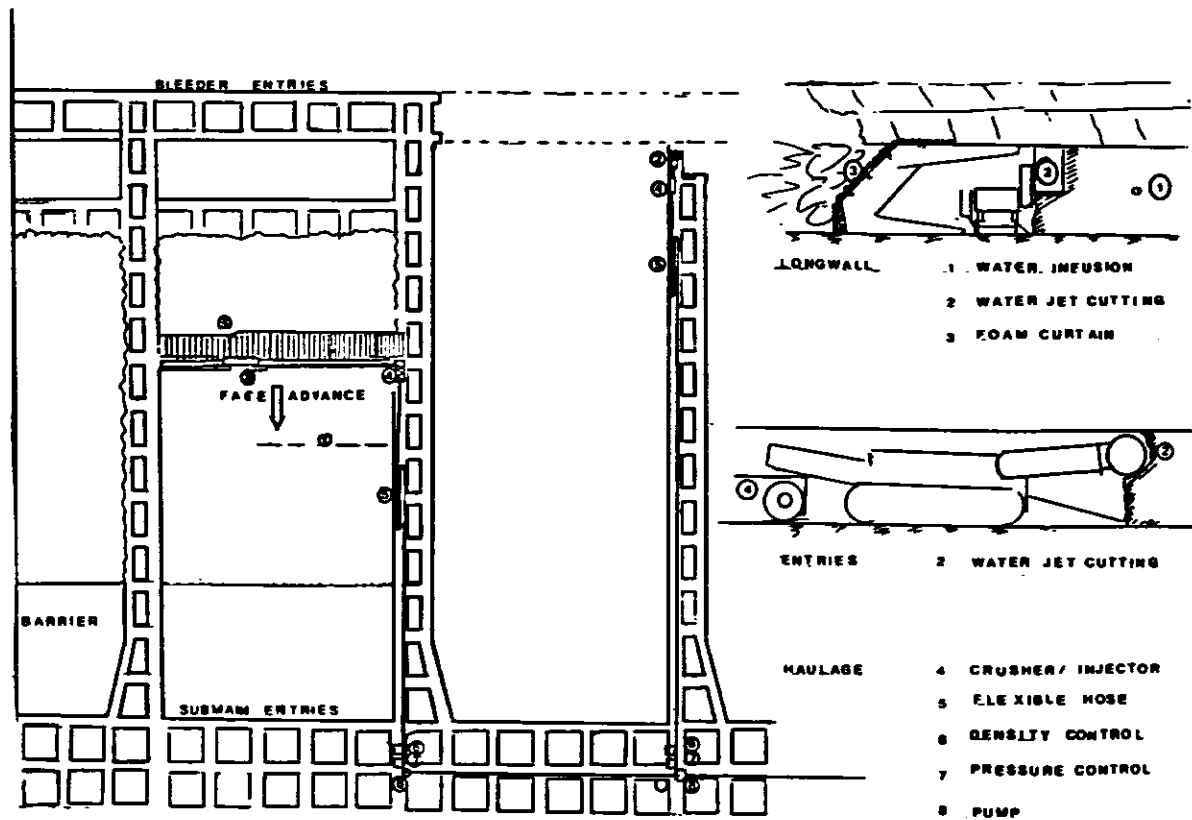

Figure 6. Overview of a dust free coal mine.

size consist and the nature of the raw coal to the length of each branch of the network.

The investment required for hydraulic transport is only half of the cost of the equivalent belt system but there is always a risk factor when comparing a conventional system to a new one. Whatever the risk, it creates a psychological barrier even though the anticipated problems are technically easy to solve:

- Speed control of each pump to maintain an appropriate slurry density to avoid settling of the products; an expert program can be based on accurate density measurements at each produce inlet.
- Pressure control of the network to detect plugging or leaks.

The most difficult problem is to start the network full of slurry after an unexpected stop due, for instance, to a power failure, but several solutions exist.

CONCLUSION

The problem of respirable dust can probably be solved if there is enough will to do it. Some alleviations can be obtained easily but a dust free mine requires hydraulic transport. Such a change in underground coal mining means risks to

face and problems to solve but will increase productivity, lower mining cost and protect miners' health.

REFERENCES

1. Thimons, E.D.: Underground Testing of a Water-Jet-Assisted Longwall Shearer. *U.S. Bureau of Mines Technology News* No. 298 (1988).
2. Nienhaus, K., Weigelt, H., Thimons, E. D.: The Development of a Water-Jet-Assisted Shearer Loader. *8th International Symposium on Jet Cutting Technology*. Durham, G.B. (1986).
3. Adam, R.F.J.: Retrofitting Shearers and Continuous Miners with Water Jet Assist Cutting. *Third U.S. Water Jet Conference*. Pittsburgh, (1985).
4. Barham, D.K., Tomlin, M.G.: High Pressure Water Jet Assisted Rock and Coal Cutting With Boom Type Roadheaders and Shearers. *8th International Symposium on Jet Cutting Technology*. Durham, G.B. (1986).
5. Cervik, J., Sainato, A., Deul, M.: Water Infusion of Coal beds for Methane and Dust Control. *Bureau of Mines Report of Investigation* No. 8241 (1977).
6. Alexander, D.W., Shaw, R.L.: Loveridge Coarse Coal Slurry System. *Rapid Excavation and Tunneling Conference*, Chicago (1983).
7. Burnett, M., Miscoe, A.J.: A Coarse Coal Injector for Hydraulic Haulage Developed for the U.S. Department of Energy. *Hydrotransport 5* (1978).
8. Sevim, H., Yegulalp, T.M.: Optimization of Hydraulic Haulage Systems in Underground Coal Mines. *Mining Engineering*: 1659, 1666 (1984).
9. Pimentel, R.A., Adam, R.F.J.: Control of Respirable Quartz in Continuous Mining Sections. *SME-AIME Annual Meeting*. New York (1985).
10. Adam, R.F.J.: Pre-Bolting System for Underground Mines *U.S. Patent* No. 4, 653, 810 (1987).

COMPARATIVE INHALATION HAZARDS OF TITANIUM DIOXIDE, SYNTHETIC AND NATURAL GRAPHITE

SANDRA A. THOMSON, Ph.D. • David C. Burnett, B.S. • John C. Carpin, Ph.D.
• Jeffrey D. Bergmann • Roger J. Hilaaki, M.S.

U.S. Army Chemical Research, Development and Engineering Center, APG, MD 21010-5423, USA

Occupational exposure to airborne graphite may occur in manufacturing and application processes. Synthetic graphite (SG) is a pure crystalline form of carbon from high temperature treatment of petroleum products, contains less than 1% quartz and is regarded as a "nuisance" dust (ACGIH TLVs®). Natural graphite (NG) is the mineral form of graphitic carbon and contains associated silicate minerals. A series of inhalation studies were conducted to study the effects of crystalline silica on graphite pneumoconiosis; titanium dioxide (TiO₂) was used as a negative control. Fischer 344 rats were exposed by inhalation to 100 mg/m³ SG, NG and TiO₂ for 4 hrs/day for 4 days. At 24 hrs and 14 days post-exposure (PE), exposed and air control rats were evaluated for bronchoalveolar lavage (BAL), physiological, pathological changes. Previous acute inhalation studies with crystalline silica resulted in persistent BAL changes correlated with adverse histopathology. BAL analysis detects differences between "nuisance" dusts and silica. Inhalation of NG containing 1-2% crystalline silica resulted in reversible BAL effects similar to other "nuisance" dusts (SG, TiO₂). Impairment of lung clearance from high dust burdens with greater silica content may be the causative factor in graphite pneumoconiosis. (Supported by the U.S. Army Biomedical Research Development Laboratory.)

INTRODUCTION

Synthetic and/or natural graphite dust may have military applications which could result in inhalation hazards. CRDEC has tested synthetic (Asbury Micro 260) and natural (Asbury Micro 650) graphites and found that acute inhalation exposure in Fischer 344 rats resulted in a mild reversible inflammatory response at high concentrations (500 mg/m³) for the synthetic material.²¹ A repeated inhalation study with the synthetic graphite also showed more changes at a lower concentration (100 mg/m³) reversible at 3 months post-exposure (PE).²² The purpose of this study was to compare the toxicity of natural and synthetic graphite using titanium dioxide as a negative control. Both synthetic graphite and titanium dioxide are classified as "nuisance dusts" as defined by ACGIH.³ Purported "nuisance" dusts have a history of little adverse effect and do not produce significant organic disease or toxic effect when exposures are kept under control. A Threshold Limit Value (TLV) of 10 mg/m³ of total dust (less than 1% quartz) is recommended for "nuisance" dusts for a normal workday. For materials containing more than 1% quartz, the environment should be evaluated against

the TLV of 0.1 mg/m³ for respirable quartz. The natural graphite used in this study contains 1.85% silica and chemically may not meet the nuisance dust requirement; however, this material may behave biologically like other nuisance dusts (synthetic graphite and titanium dioxide). According to the ACGIH, the biological criteria of a nuisance dust is defined by the following lung tissue reaction: 1) the architecture of the air spaces remains intact; 2) collagen (scar tissue) is not formed to a significant extent; and 3) the tissue reaction is potentially reversible. In addition to these histopathological indicators of toxicity, pulmonary function and bronchoalveolar lavage (BAL) were used to compare the toxicity of these graphite dusts to titanium dioxide.

MATERIALS AND METHODS

Experimental Design and Test Materials

Groups of 20 male Fischer 344 rats (CDF/Crl BR), commercially procured from Charles River Laboratories, were exposed by whole body inhalation to 100 mg/m³ of each test material on four consecutive days, four hours/day. At 24 hrs and 14 days PE, exposed and air control rats were evaluated for BAL, physiological and pathological changes. Toxic observations were recorded daily and weights were taken at weekly intervals.

The synthetic graphite used in this study is Asbur Micro 260 (less than 1% silica) and the natural graphite is Asbur Micro 650 (1.85% silica). The titanium dioxide was a gift from NL Chemicals Inc. and is a high purity rutile form of titanium dioxide. All three test materials contained negligible amounts of contaminants.

Chamber Operation

The Hazelton 2000 liter stainless steel inhalation chambers were used for this study. A unique feature of the chamber is the multi-tier arrangement of the cage units and catch pans which facilitates good mixing within the chamber and helps promote a nearly uniform aerosol concentration throughout the chamber.¹² This uniformity has been verified by both fixed point aerosol sampling measurements, residence time distribution measurements, and flow visualization studies.^{2,13} Four Hazelton 2000 liter chambers were set up as shown in Figure 1 under climate controlled conditions (temperature = 74° ± 4°; relative humidity = 40% ± 10%). All four chambers were manifolded to a single blower unit which pulls air from the surrounding room through each of the chambers; all air was filtered prior to being exhausted

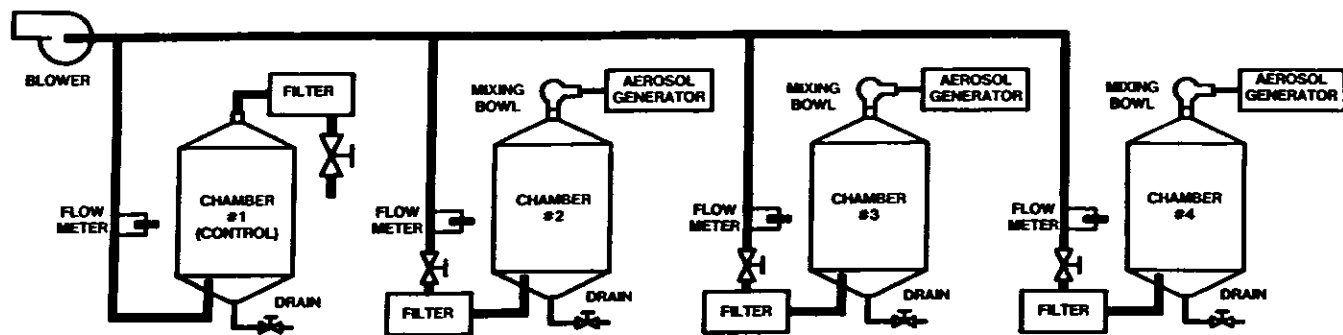

Figure 1. Exposure facility.

outside. The inlet ports to the exposure chambers were each fitted with 15 liter glass mixing bowls to aid in aerosol dispersal and the control chamber and was fitted with a particulate filter on its input in place of a mixing bowl. Each chamber exhaust line has an orifice meter downstream of the particulate filter for the purpose of monitoring chamber flow. Gate valves provided on each chamber enable course flow regulation.

The aerosol generation system for titanium dioxide consisted of an AccuRate series 300 screw feeder and attached vibration device which metered the dust at a uniform rate to a Jet-O-Mizer aerosol mill depicted in Figure 2. The aerosol mill was equipped with air jets supplied with compressed air at 55 psig. High velocity air emanating from the jets resulted in high particle to particle shear forces which readily caused the break up of agglomerates. Consequently, a relatively highly dispersed aerosol was produced at the outlet of the aerosol mill.

The AccuRate series 300 feeders were also used to deliver the graphites to the dust generators. Dispersion of the graphite dusts was accomplished using a Metronics aerosol generator depicted in Figure 3. This device is in essence a centrifugal blower with a deep bladed impellor. Feed material falls into the center of the impellor and is driven against the blades by centrifugal force resulting in particle deagglomeration and dispersion. The resultant aerosol was fed directly into the chamber mixing bowl. The appropriate blower speed was determined during the calibration phase and was regulated by means of a variance.

Prior to the start of exposures, calibration of the chamber was conducted to assure a stable concentration. The aerodynamic particle size of each test material was determined using a Sierra® Instruments cascade impactor (Model 2210-K, 10 stage). The mass median aerodynamic diameter (MMAD) and geometric standard deviation (σ_g) of each test material were determined during the calibration and exposure phases of the study. The MMAD in micrometers and the (σ_g) were 2.38 (2.61) for natural graphite, 2.27 (2.57) for synthetic graphite, and 1.50 (2.25) for titanium dioxide.

The average concentrations for the four days of exposure for each test material were: 102.1 mg/m³, natural graphite;

100.4 mg/m³, synthetic graphite; and 101.5 mg/m³, titanium dioxide. The overall coefficient of variation for concentration was less than 15 percent.

Biological Evaluations and Data Analysis

Lung lavage and pulmonary physiological testing were performed on the same animal to enable correlation of biochemical changes with functional changes. The details of the physiological evaluations and BAL analyses were previously described by Thomson et al.¹⁸ Macrophage concentration was determined in a hemocytometer and cell viability was conducted via the trypan blue exclusion test.⁷

At 24 hours and 14 days PE, the test and control rats identified for pathological evaluation were killed using carbon dioxide gas and complete necropsies were performed by Pathology Associates Inc., Ijamsville, Md. All tissues were fixed in 10% neutral buffered formalin, trimmed, dehydrated, embedded in paraffin, sectioned at 6 μ m and stained with hematoxylin and eosin. Representative sections were examined for all test groups and controls.

Data analysis was conducted according to a statistical "decision tree" as described by Gad and Weil.⁵ First, Bartlett's Test for homogeneity of variance was used as a check of the assumption of equivalent variances, followed by the use of ANOVA (analysis of variances). Non-parametric, heterogeneous data was analyzed by the Kruskal-Wallis non-parametric ANOVA. Finally, Dunnett's Test was used on parametric homogeneous data to identify significantly different groups.

RESULTS

Physiological and Bronchoalveolar Response

Throughout the entire study, the control and test animals gained weight at the same rate; there were no statistically significant differences between the groups. There were no adverse toxic signs exhibited by the animals, normal activity occurred pre and post exposure. The graphite exposed rats were charcoal colored following exposure and remained "dirty" looking throughout the 14 day post exposure period despite some preening. The pulmonary physiological evaluation of the rats exposed to titanium dioxide and graphite dusts

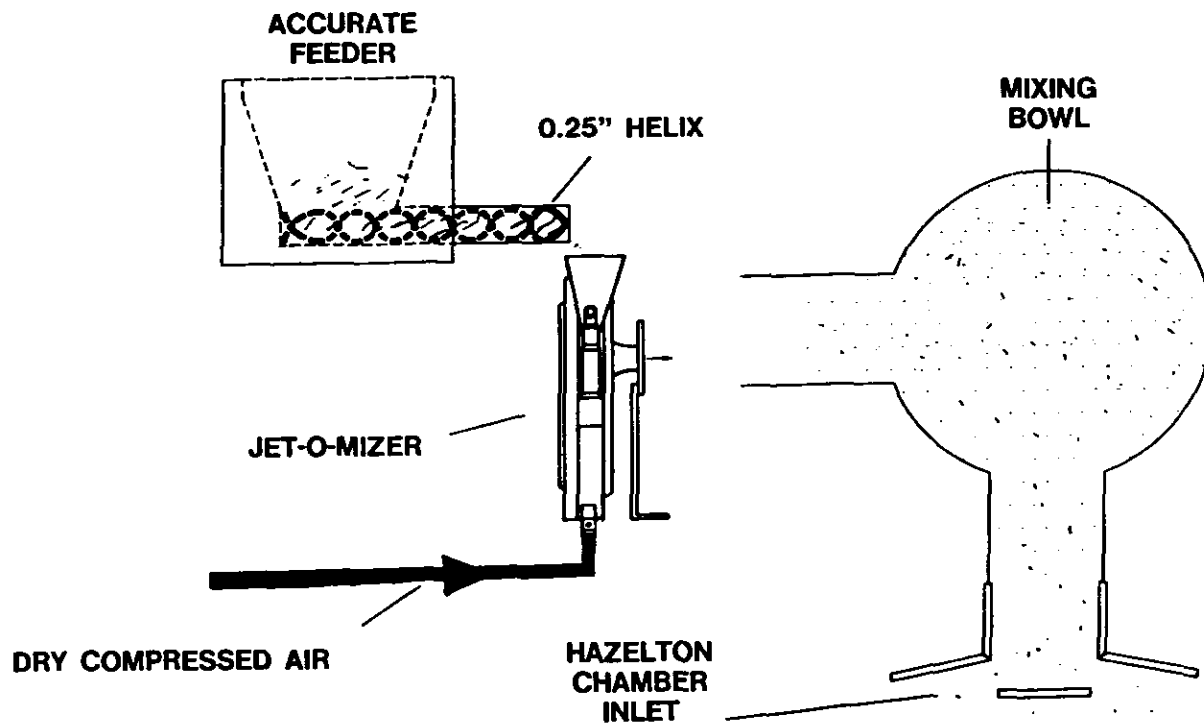

Figure 2. TiO₂ aerosol generation system.

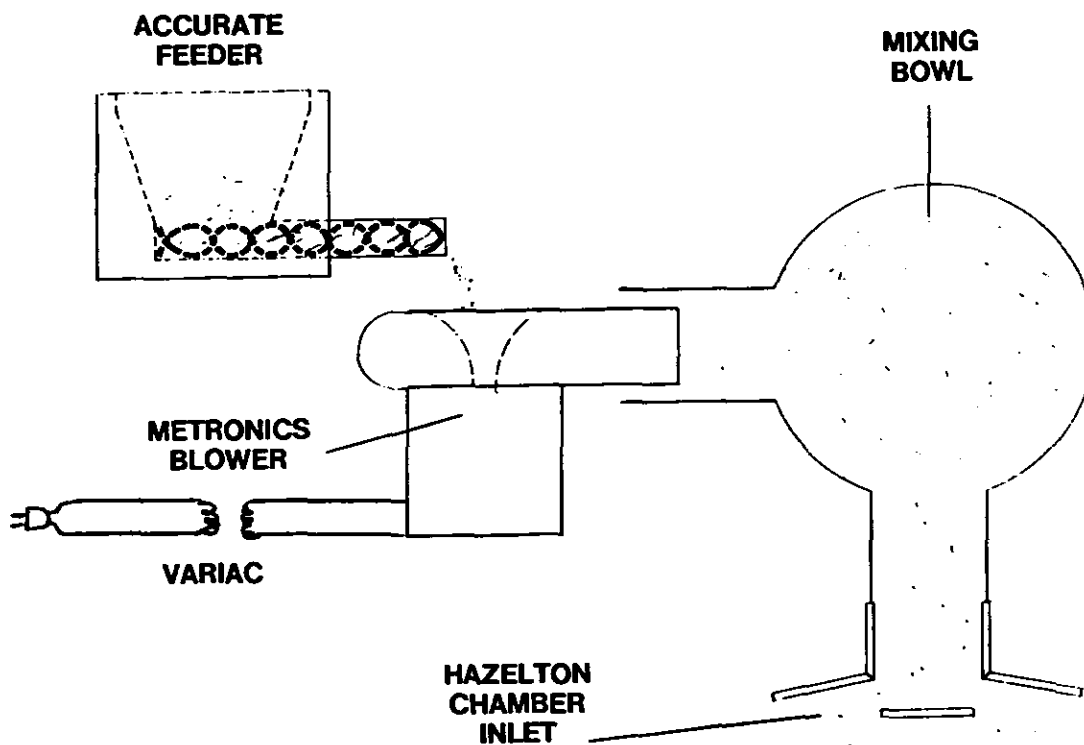

Figure 3. Graphite aerosol generation system.

showed an apparent statistically significant decrease in pulmonary resistance at 24 hours PE in the rats exposed to synthetic graphite and a significant increase in respirator rate at 14 days PE in the rats exposed to titanium dioxide. Neither of these apparent changes has any biological significance. Previous acute and repeated inhalation studies on synthetic graphite did not result in any consistent significant changes in pulmonary resistance.^{21,22}

The enzymatic and protein analyses of the lavage fluid are summarized in Figure 4. There were significant increases in protein at 24 hours PE with all three dusts but at 14 days all values were within control levels. At 24 hours PE, there were significant increases in β -Glu and ALKP for both graphite dusts and an increase in LDH for the natural graphite. There was an unexplainable decrease in ALKP for titanium dioxide which may be caused by a material interference with the assay; this effect is being investigated. By 14 days PE, all enzymatic changes were resolved.

Cytological analyses of the lavage fluid are listed in Table I. All three dusts exhibited an influx of polymorphonuclear neutrophils (PMN) at 24 hours PE but the graphite dusts elicited a greater PMN response. Likewise, natural graphite exposure resulted in the largest increase in total cells. By 14 days PE, the PMN response had diminished to almost control levels. There was no decrease in macrophage viability from exposure to any of the test materials.

Pathological Evaluations

The gross observations noted at the time of necropsy indicated that several of the graphite exposed rats had discolored or mottled lungs. There were no apparent differences in body or organ weights. Treatment related changes were present in the lungs of all exposed rats consisting of brown to black, isotropic pigment. At 24 hours PE in all cases, the pigment was present either free or within macrophages in terminal airways and alveoli. Microscopically, the three types of pigment were indistinguishable from each other. There was no pigment in the peribronchial lymph nodes and no adverse tissue reaction to it. By 14 days PE, there was no free pigment (extracellular) in the lungs of the exposed rats. Again, the three types of pigment were indistinguishable; however, in the graphite exposed rats, the pigment-laden macrophages tended to be aggregated in small groups more than in the titanium dioxide exposed rats. The only other changes were two minimal foci of epithelial hyperplasia in the alveoli and/or the terminal bronchioles of three rats exposed to synthetic graphite and one rat exposed to titanium dioxide. The pigmented macrophages were not associated with the hyperplasia. It was concluded that the degree of pigmentation was mild in all exposed rats and nearly identical within and between groups.

DISCUSSION

Inhalation exposure of Fischer 344 male rats to 100 mg/m³ of titanium dioxide, natural and synthetic graphite dusts for 4 hrs/day for four days resulted in minimal adverse effects. There were no adverse toxic signs following exposure, no mortality and no consistent pulmonary function changes. All the rats gained weight at the same rate as the controls. BAL analyses resulted in increases in protein for all three

materials; increases in β -Glu and ALKP for both graphites; and increases in LDH for natural graphite at 24 hours PE. The increase in LDH is reported to be indicative of damage to the pulmonary Type I cells while ALKP increases may be correlated with Type II cell hyperplasia.⁸ Type II cell hyperplasia was only observed in three rats at 14 day PE, two from the synthetic graphite exposed group and one from the titanium dioxide exposed group. This effect was observed in a previous study where rats were exposed to 100 mg/m³, 2 hours/day, 5 days/wk for two weeks.²² Perhaps a longer repeated exposure would have resulted in more Type II cell hyperplasia in this study. Since Type II cells are the progenitors of Type I cells,⁴ this would be an indicator that the damaged alveolar epithelium is undergoing repair and replacement. The graphite exposed rats also had increases in β -Glu which is a lysosomal enzyme released by phagocytic cells in response to inflammation.⁸ These enzymatic changes correlate with the BAL cytological profile (i.e., increases in PMN and total nucleated cells), which are indicative of an inflammatory response. By 14 days PE, all BAL alterations were resolved.

The histopathological evaluation revealed mild lung pigmentation in all the exposed rats with more aggregates of pigment in the graphite exposed rats at 14 days PE. The macrophages seen in the alveoli appear to be actively phagocytizing all three materials. There was no decrement in macrophage viability which is in agreement with previous studies with synthetic graphite and titanium dioxide.¹ No pigment was observed in the peribronchial lymph nodes; this was expected since in prior inhalation studies with graphite, pigmentation in the lymph nodes was not evident until 3 months PE. Clearance of these dusts may be a slow, protracted process.

The BAL changes seen after repeated exposure to graphite were more severe than the changes following a single exposure. Previous acute inhalation exposure to graphite resulted in minimal cytological changes reversible by 14 days PE and no enzymatic BAL changes.²¹ However, the BAL response in this study is mild compared to the dramatic inflammatory reactions observed in acute studies with brass powder,¹⁸ and is not as persistent as the effects seen with aluminum

single 100 mg/m³ inhalation exposure to quartz, BAL enzymes were elevated two to five hundred percent over controls at 3 days and 3 months PE. The changes with graphite were minimal and reversible.

The repeated inhalation studies in this report and the previous acute inhalation exposure to synthetic graphite even at very high concentrations (500 mg/m³ does not result in any permanent effects. This is in agreement with the OSHA¹⁴ and Documentation of TLVs³ guidelines which regard synthetic graphite as a nuisance dust. The higher quartz content (> 1%) of natural graphite supposedly accounts for the greater risk of developing fibrosis; thus, natural graphite is assigned a TLV of 2.5 mg/m³. However, this hypothesis is not conclusive; a survey of the literature on the etiology of coalworkers' pneumoconiosis (CWP) reveals uncertainty as to what part quartz plays in pathogenesis.¹⁵ Several studies in animals have implicated quartz as the causative factor in

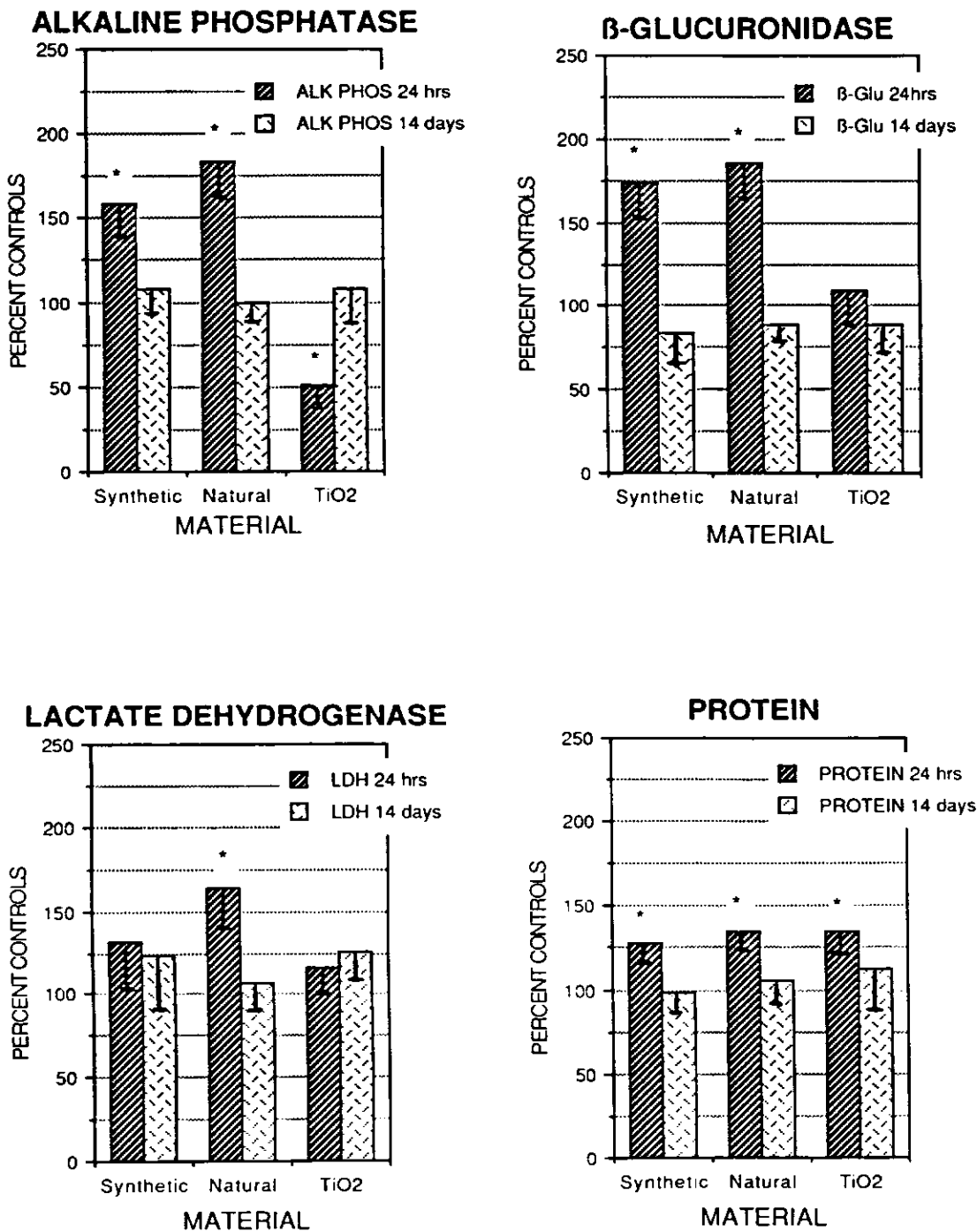

*SIGNIFICANT IN DUNNETT'S TEST @ P ≤ .05

Figure 4. BAL results for graphite and TiO₂ exposed rats.

Table I
Cytological Analysis of Bronchoalveolar Lavage Fluid

	WBC x10 ³	TOTAL x10 ⁴	VIABILITY %	MACROPHAGE %	LYMPH %	PMNS %
24 Hours Post Exposure						
CONTROL	x 2.22 s 0.50	4.34 1.51	97	98 2	2 1	0 0
SYNTHETIC	x 2.40 s 0.46	5.18 0.89	95	56 7	1 0	43 7
NATURAL	x 3.37* s 0.73	6.10 1.26	94	46 10	2 1	52 10
TITANIUM OXIDE	x 1.45 s 1.20	6.22 2.07	96	85 15	4 5	11 11
14 Days Post Exposure						
CONTROL	x 2.00 s 0.66	4.41 1.11	98	97 2	2 1	1 1
SYNTHETIC	x 2.13 s 0.43	5.29 1.01	98	92 7	3 3	5 4
NATURAL	x 2.58 s 0.57	6.12* 0.61	99	92 4	2 1	6 4
TITANIUM OXIDE	x 1.88 s 0.42	3.67 0.53	98	94 3	2 2	4 3
* significant p=0.05 (t-test)						

mixed dust fibrogenesis. Martin et al.¹¹ found collagen formation after 18 months in the lungs of rats that had inhaled a coal mixture with 5% quartz for 80 days. At concentrations above 10% quartz, the formation of fibrotic nodules and collagen occurred at a rate five times higher than coal alone. Further confirmation of this theory was demonstrated by Schlipkoter et al.¹⁸ in experiments where quartz, coal and titanium dioxide, alone and in mixtures, were administered to rats intraperitoneally. Fibrosis was induced when quartz was added to the mixtures and the authors concluded that whenever quartz is present in a particular mine dust producing CWP, it should be considered the dangerous agent. This interpretation according to Parkes¹⁵ is contradicted by a number of observations in human beings. Both simple pneumoconiosis (benign dusty lung) and progressive massive fibrosis have occurred in men exposed to artificial or quartz-free graphite.^{6,16,17} In each case, quartz was absent or less than 1% in the lungs; therefore, such instances imply quartz is not the pathogenic factor. The controversy is more than an academic debate since occupational exposure standards are based upon the quartz content of the dust in question (eg. graphite). Recent epidemiological studies in British mines showed that an apparent increase in the prevalence of pneumoconiosis with increasing quartz exposure is reversed in the presence of high clay mineral exposure (aluminum silicate clays are known to inhibit silicosis) and that mass concentration of respirable dust is the best exposure index when the quartz content does not exceed 7.5%.¹⁵ This "mass" effect of dust exposure has been recently demonstrated by the results of chronic inhalation studies conducted with titanium dioxide. Lee et al.¹⁰ found fibrosis and bronchoalveolar adenomas in the lungs of rats exposed to 250 mg/m³ of titanium dioxide for 6 hrs/day, 5 days/wk, for 2 years. The pulmonary lesions were the result of overwhelming the lung clearance mechanisms.

CONCLUSIONS

Repeated inhalation exposure of Fischer 344 rats to 100 mg/m³ of titanium dioxide, natural graphite, and synthetic graphite for 4 hours/day for four days resulted in a mild inflammatory response 24 hours PE. BAL changes were the most sensitive indicator of damage; although the enzymatic and cytological alterations were evident with all three materials, there were greater increases with the graphite dusts. Even though the graphite dusts and titanium dioxide were still present in the alveolar macrophages of each respective group of rats, by 14 days PE, all BAL changes were resolved. This seems to indicate that the initial period of inflammation had ceased and a slow clearance was in process. There appears to be no deleterious tissue reaction to any of the materials at the levels tested in this study.

In this experiment, synthetic graphite, natural graphite, and titanium dioxide meet the criteria of the ACGIH for a nuisance dust: (1) the architecture of the air spaces remained intact; (2) collagen (scar tissue) was not formed; and (3) the tissue reaction was potentially reversible. Repeated exposure to graphite dust results in more pulmonary damage than single exposures. If the nuisance dust TLV (10 mg/m³) is exceeded, respirator protection should be utilized.

REFERENCES

1. Anderson, R.S., Gutshall, L.L., Thomson, S.A.: *Rat Pulmonary Alveolar Macrophages in Vitro Cytotoxicity to Six Metal Dusts*. U.S. Army CRDEC Technical Report #88037, APG, MD (1987).
2. Beethe, R.L., Wolff, R.K., Griffis, L.C., Hobbs, C.H., McClellan, R.O.: *Evaluation of a Recently Designed Multi-Tiered Exposure Chamber*. Inhalation Toxicology Research Institute Report LF-67, Lovelace Biomedical and Environmental Research Institute, Albuquerque, NM (1978).
3. *Documentation of the Threshold Limit Values and Biological Exposure Indices*, fifth edition, American Conference of Governmental Industrial Hygienists, Cincinnati, OH (1986).
4. Evans, M.J.: Cell Death and Cell Renewal in Small Airways and Alveoli, chap. 5 in *Mechanisms in Respiratory Toxicology*, vol. 1, Witschi, H., Nettekheim, P. (eds.), CRC Press, Boca Raton, FL (1982).
5. Gad, S.C., Weil, C.S.: Statistics for Toxicologists, in *Principles and Methods of Toxicology*, edited by A.W. Hayes, pp. 273-320. Raven Press, NY, NY (1984).
6. Gaensler, E.A., Cadigan, J.B., Sasahara, A.A., Fox, E. O., MacMahon, H.E.: Graphite Pneumoconiosis of Electrotypes. *Am. J. Med.* 41:864-882 (1966).
7. Hanks, J.H., Wallace, J.H.: Determination of Cell Viability. *Proc. Soc. Exp. Biol. Med.* 98:188-182 (1958).
8. Henderson, R.F., Rebar, A.H., Pickre11, J.A., Newton, G.J.: Early Damage Indicators in the Lung III. Biochemical and Cytological Response to inhaled Metal Salts. *Toxicol. Appl. Pharmacol.* 50:123-136 (1979).
9. Henderson, R.F., Rebar, A.H., DeNicola, D.B., Henderson, T.R.: The Use of Pulmonary Lavage Fluid in Screening for Early Indicators of Lung Injury, in *Pulmonary Toxicology of Respirable Particles*. pp 378-391. Sanders, C., Cross, F., Cagle, G., (eds.) Tech. info. Center, DOE, Springfield, VA (1980).
10. Lee, K.P., Trochimowicz, H.J., Reinhardt, C.F.: Pulmonary Response of Rats Exposed to Titanium Dioxide by Inhalation for Two Years, *Tox. Appl. Phar.* 78:179-192 (1985).
11. Martin, J.C., Daniel-Moussard, H., LeBouffant and Policord, A.: The Role of Quartz in the Development of Coal Workers' Pneumoconiosis, *Ann. N.Y. Acad. Sci.* 200:127-141 (1972).
12. Moss, O.R.: A Chamber Providing Uniform Concentration of Particulates for Exposure of Animals on Tiers Separated by Catch Pans, in *Proceedings Workshop on Inhalation Chamber Technology*, edited by R.T. Drew, Brookhaven National Laboratory Report 51318, pp. 31-37 (1978).
13. Moss, O.R.: Comparison of Three Methods for Evaluation of Inhalation Chamber Performance, in *Proceedings of the Inhalation Toxicology and Technology Symposium*, edited by B.K. J. Leong, Ann Arbor Science Publishers, pp. 18-28.(1980).
14. Occupational Health Guideline for Natural Graphite, *NIOSH/OSHA Occupational Health Guidelines for Chemical Hazards*. DHHS (NIOSH) publ. #81-123, U.S. Govt. Printing Ofc., Wash. D.C.(1978).
15. Parkes, W.R.: *Occupational Lung Disorders*, chap. 8. Butterworths, Boston, MA, (1985).
16. Pendergrass, E.P., Vorwald, A.J., Mishkin, M.M., Whildin, J.G., Werley C.W.: Observations on Workers in the Graphite Industry, par 1 *Med. Radiogr. Oigitr.* 43:70-99 (1967).
17. Ruttner, J R., Bovet, P., Aufdermaw, M.: Graphite Carborund Stablunge, *Dt. Med. Wschr.* 77:1413-1415 (1952).
18. Schlipkoter, H.W., Hilscher, W.: Antagonistic Factors in the Pathogenesis of Coal Workers' Pneumoconiosis, *Ann. N.Y. Acad. Sci.* 200:166-181 (1972).
19. Thomson, S., Burnett, D.C., Bergmann, J.D., Hixson, C.J.: Comparative Inhalation Hazards of Aluminum and Brass Powders Using Bronchopulmonary Lavage as an Indicator of Lung Damage, *J. Appl. Tox.* 6(3):197-208 (1986).
20. Thomson, S.A., Burnett, D.C., Hilaski, R.J., Hixson, C.J.: Bronchoalveolar Responses of Rats to Acute Inhalation of Quartz, *Toxicologist* 6:134 (1986).
21. Thomson, S.A., Burnett, D.C., Anderson, R.S., Hilaski, R.J.: Pulmonary and Pathological Responses of Rats to Acute Inhalation of Synthetic Graphite, *Toxicologist* 7:199.(1987).
22. Thomson, S.A., Crouse, C.L., Burnett, D.C., Hilaski, R.J.: Repeated Inhalation Toxicity Study of Synthetic Graphite in Rats, *Toxicologist*, 8:252. (1988).

THE STUDY ON THE RELATIONSHIP BETWEEN BREATH DUST VALUE (BDV) AND PNEUMOCONIOSIS

LIU ZHANYUAN • Feng Yuxiang • Xiao Xingyuan • Feng Jizhang

Liaoning Institute of Labour Hygiene, P.R. China

INTRODUCTION

How to determine the exposed-dust volume is the key index in the study on the relationship between dust and pneumoconiosis. Hatch once used the product of dust concentration (mg/m³) by labour age as exposed-dust volume. Authors, after long kinematic observation, discovered that the incidence rate of pneumoconiosis had significant difference in labour strength, under the same mg. Yes, its cause was related to breath volume. It is verified that the difference in breath volume is greater and it is extremely reached 1:2:3 in the labour strength medium and heavy.

Therefore, the author proposed the breath dust value obtained by multiplying dust concentration exposed time by labour breath value as the index of exposed-dust volume. The following is the studied results on the relationship between BDV and pneumoconiosis.

METHOD OF STUDY

Two plants were chosen as observation targets where the conditions of dust prevention and production were stable and the workers were exposed to silica dust and had little mobility.

1. Established strict regulations of environment supervision (to measure dust concentration once a month), and health guardianships (to make health examinations once a year). The occupational history and examination results were recorded on "health cards," while the results of measured dust were recorded on "labour hygiene cards."
2. Measured exposed time labour breath volume, oxide exhausted and energy exhausted in a shift in different types of work, and determined the breath volume and labour strength in different types of work according to the measured results.
3. Computed the BDV for all exposed workers and pneumoconiosis cases, and then analyzed the relationships between BDV and pneumoconiosis.

RESULTS

According to the studied results, specified a table of breath volume under various labour strengths as shown in Table I, and then determined breath volume in light, medium, and heavy. According to formula (1), calculate BDV.

$$X = \sum_{i=1}^n (K \langle CHT \rangle) i \quad (1)$$

where:

- X—BDV accumulate value;
- C—average dust concentration (mg/m³);
- H—labour breath volume (l/min);
- T—exposed years of standing (year × shift × min);
- K—adjusted index of time unit (0.144).

When dealing with the data of retrospective study, use the average dust concentration of year and month as the basis for calculating BDV. But in prospective study, it is best to use the average dust concentration in a shift as a basis of calculating BDV. Labour time (min), labour breath volume (l/min) and personal exposed concentration (mg/m³) must be practically measured data.

First, calculate BDV in a shift, then, according to number of worker's shifts determine accumulated value of BDV.

Figure 1 shows the statistical results of the relationship between BDV and accumulated incidence rate of pneumoconiosis from 706 exposed workers in plants A, B.

Table II shows the statistical results of BDV in 42 pneumoconiosis cases in different phases in plant A. The BDV from pneumoconiosis in different phases has significant difference by T test. The greater the difference of BDV is, the more serious the phase of pneumoconiosis.

Figure 2 shows the results of relationship between BDV and fatality rate through 20 years of observation. The greater the BDV is, the higher the fatality rate. When analyzing the relationship between "exposure standing up to diagnosis" and BDV in average years, it was found that there is a straight correlation of BDV in average years with "exposure standing up to diagnosis" as shown in Figure 3. The smaller the BDV average is, the longer "exposure standing up to diagnosis" of pneumoconiosis is.

The BDV of average years in 1 phase pneumoconiosis was obtained by accumulated BDV in 1 phase pneumoconiosis divided by "exposure standing up to diagnosis," which provided the proof for searching the limit value of BDV in pneumoconiosis

Table I
Strength versus Breath Volume

Strength	Energy exhausted (l/min)	Breath volume (l/min)
light		10 - 20
medium		21 - 35
heavy		36 - 50

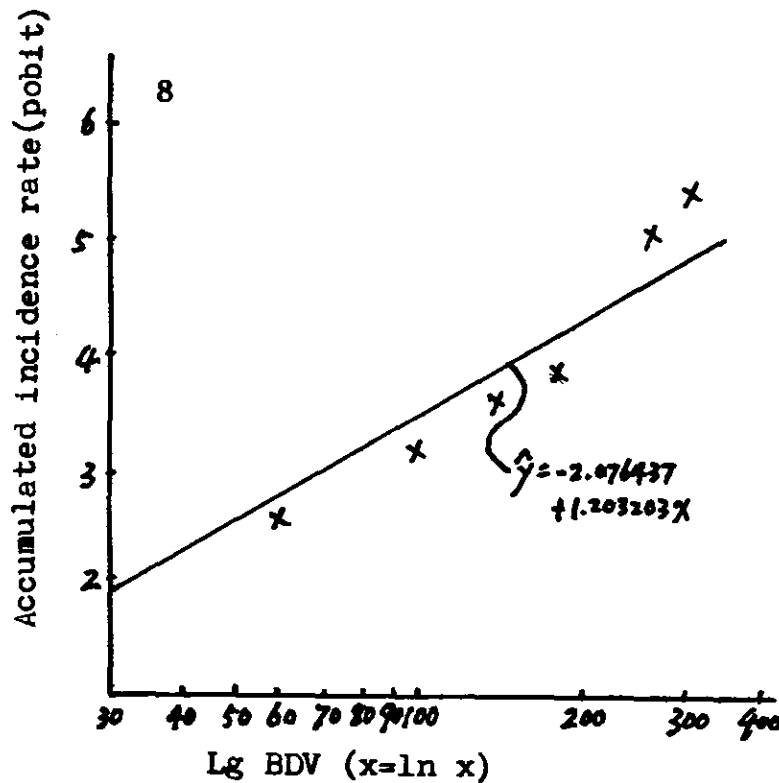

Figure 1. The relationship between BDV and the incidence rate of pneumoconiosis.

According to the closed relationship between the occurrence and development of pneumoconiosis and BDV, from the correlation of BDV in average years with "exposure standing up to diagnosis," the author provided the formula of calculating dust allowable concentration.

(2)

where:

- D — dust allowable concentration;
- g — logarithmically geometric mean of BDV in I pneumoconiosis;
- Sg — logarithmically standard error of geometric mean of BDV in I phase of pneumoconiosis;
- $t_{0.05}(n')$ — one-sided value obtained by the statistical number of cases N and degrees of freedom N-1 in table.
- T — the specified breath volume under the certain labour strength;
- T — the longest labour age of exposed workers;
- K — factor 0.144 adjusted by time unit.

Table II
BDV in 42 Pneumoconiosis Cases

Phases of pneumoconiosis	Statistical cases	Average of BDV
0 - 1	7	846.09
1	12	1890.39
2	10	8185.50
3	13	15636.48

See the following example from the original data of BDV of 27 cases in 1 phase pneumoconiosis in plant B as shown in Table III.

where:

1. logarithmically geometric mean $g=2.4119$;
2. logarithmically standard deviation $Sg=0.3488$;
3. $t_{05}(26) = 1.706$;
4. labour breath volume, 20 l/min;
5. the longest exposed labour ages, 30 Yrs.
6. $K = 0.144$
 $D = \lg^{-1} (2/411.9 - 1.706 \cdot 0.3488 - \lg(30 \times 0.144 \times 20))$
 $= 0.76 \text{ (mg/m}^3\text{)}$

DISCUSSION

The key problem in the survey is how to determine the relationship of dose-response between dust and pneumoconiosis. Dutoid, Risner, Bedlle, etc. have studied the above problem and proposed various indexes after Hatch. Among these indexes are dust concentration and the most basic parameters. But they all do not involve the labour strength.

The author considered that labour strength shouldn't be ignored according to studied results. Because of various labour strength effects on labour breath, which effects the dust deposit rate in the respiratory tract, it is related to inhaled dust volume. Therefore, the important factor of labour breath volume should be induced into the calculation of three factors of dust concentration (c), exposed time (T) and breath value (H). But, because it has a difference from practically inhaled dust volume, it should be called exposed volume named as BDV. The parameters of BDV are strong according to the different data. In the data treatment of retrospective study, although no method to recollect historic date, it is possible to calculate the BDV's factors according to the table of dust concentration in different years obtained by collected monitored data. But in introspective study, it is based on personal exposed concentration while labour breath volume and labour time should be measured practically. Still, a lot of problems about how to obtain the exact data of dust concentration need to be researched.

The Relationship Between BDV and Pneumoconiosis

Studied results, proved further that there is a dose-response relationship between dust and pneumoconiosis

Objective of investigation is these workers who were exposed to silica dust and their pneumoconiosis is the typical silicosis. In the long statistical survey of 20 years, dust monitoring and workers' health examinations were carried out by study groups, themselves under the unified planning. Most data about measured dust is measured by themselves, and diagnosed by a special diagnosis group which is composed of experts of X-ray, lungs, tuberculosis, and hygiene. So, the first-hand data is reliable, and based on that, we have confidence to search the limit value of BDV in pneumoconiosis by the relation of both of them and proposed assessment formula of dust allowable concentration. The formula's property is that data treatment is based on BDV of 1 phase pneumoconiosis. It is not easy to set data on an exposed population in an investigation of pneumoconiosis for a long time, therefore, treating the data on dynamic incidence rate is difficult. But for each record of pneumoconiosis, such as occupational dust concentration, diagnosis is actual. Most cases of pneumoconiosis occurred in major, exposed types of work. There were detailed records of occupational history, and data of dust concentration in the workplace. Other workers who were not affected by pneumoconiosis worked in unimportant, exposed type of work, where there was little detailed data of measured dust. And hence, it was very difficult to calculate exposed-dust volume. Sometimes to resolve the above mentioned problem, the method must be adopted of assession or multiplication of the data of major exposed type of work by a certain factor. Hence, the calculation of exposed-dust volume in health population is not certain. From the practical conditions, there is an actual significance to search a method with reliable data of cases of pneumoconiosis. Of course, its science and reality must be tested and proved in practice

SUMMARY

According to long studied results in a field survey, it is considered that breath volume should be introduced to reflect the difference of labour strength while calculating exposed-dust volumes and proposed calculation method of exposed-

Table III

The Example from the Original Data of BDV of 27 Cases in 1 Phase Pneumoconiosis in Plant B

27 cases in 1 phase pneumoconiosis in plant B				
175.19	246.76	261.29	310.68	259.30
92.07	252.66	1019.91	931.54	225.50
271.27	956.45	138.60	935.57	1675.58
262.11	206.66	264.96	113.68	101.11
153.34	159.47	265.20	231.82	148.28
57.11	264.35			

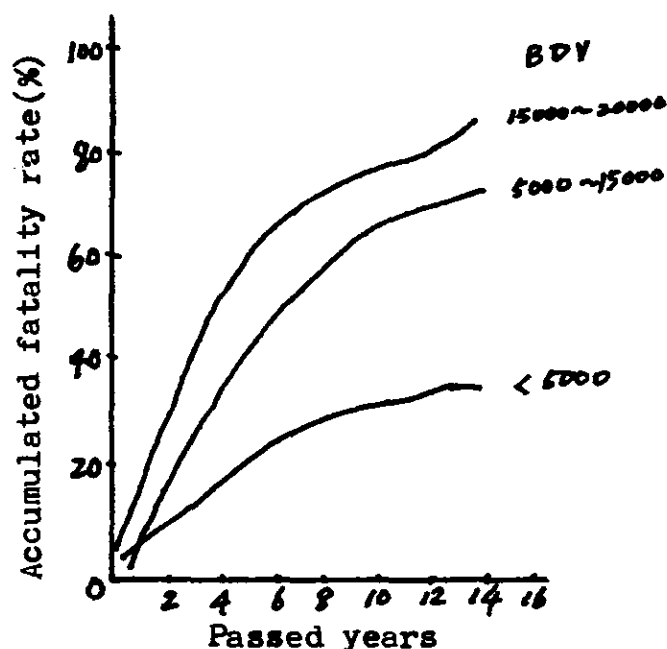

Figure 2. The relationship between BDV and the fatality rate of pneumoconiosis.

dust volumes; i.e., BDV and the studied relationship between BDV and pneumoconiosis. From the closed relationship between pneumoconiosis and BDV, the author has expounded the linear correlation of BDV in average years with "exposure standing upon diagnosis" in 1 phase pneumoconiosis, searched the limit value of BDV in 1 phase pneumoconiosis, and proposed the method of calculating dust allowable concentration, based on BDV in 1 phase pneumoconiosis.

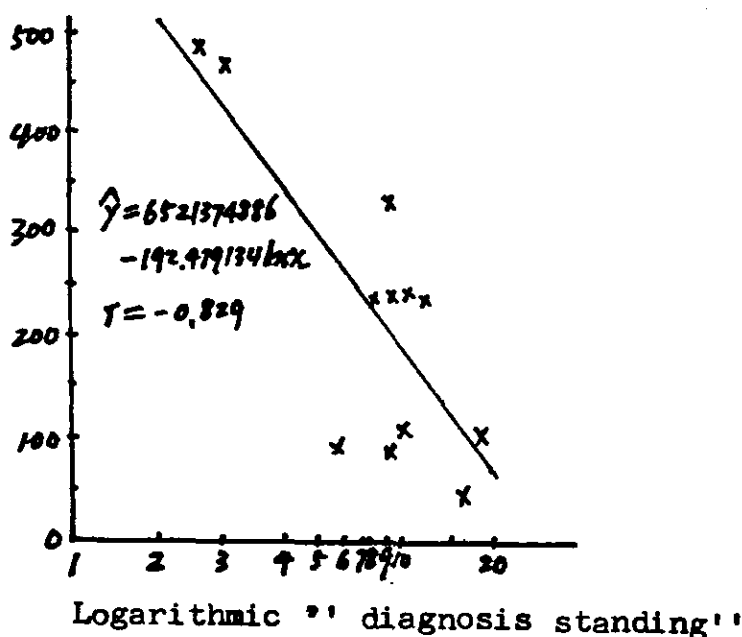

Figure 3. The relationship between BDV average years and "exposure standing upon diagnosis" in 1 phase pneumoconiosis.

REFERENCES

1. Hatch, *Am. Indust. Hyg. Assoc.* (1), 30, 1955.
2. Liu Zhanyuan, et. al.: *Chinese Journal of Preventive Medicine*, 15 (1), 17, 1981.
3. Liu Zhanyuan, et. al.: *Method of Field Investigation Indust. Allowable Concentration*, 46.

PROBLEMS OF LABOUR HEALTH ON PREVENTING DUST HAZARD IN TOWNSHIP INDUSTRIES

LIU ZHANYUAN • Xiao Xingyuan • Fang Yuxiang

Liaoning Institute of Labour Hygiene, P.R. China

Along with the changes in the rural economic structure, small township factories are on the rise and have rapidly developed. These industries, however, face some serious health protection problems. Because production techniques in many factories are often backward and, in addition, their equipment is poor, economic standards in rural areas is lower, and administration regulation is not good, these factories create environmental pollution and endanger the health of workers and local residents. So how to resolve these problems are imminent. Through making investigations in township factories of Liaoning Province for more than ten years, we expound some views about labour health problems of preventing dust hazards in township factories.

INVESTIGATION

The investigation we refer to is of dust hazards in key township factories which create dust and seriously endanger the occupational workers' health. Its purpose is know the degree of dust hazard, the cause and the consequence so that we can provide the necessary basis for finding suitable preventing measures. Through our investigation in Sueizhong and Janpin County, the west part of Liaoning Province, we found that there have been 10 crushing mills of silica and feldspar in Sueizhong and in Janpin, the township-run mining factories all over the County. Above all, there are more than 10 mining stops to process perlite. In view of representative perlite in our province, we illustrate an example of investigation in it. The results are following:

1. Dust concentration is very high.
2. Among 225 workers clear irregular shadows and some speck shadows on lung X-rays were seen. There is notable relation between FEV₁ or mmEF, and the changes of lung X-rays. The more the volume of dust exposure is, the lower the aeration functions mentioned above are.
3. We injected intra-tracheally 50mg of perlite dust into rat lungs. For 12-18 months, we observed that perlite dust caused fibrosis in rat lungs. These results proved the hazard of perlite dust, and emphasized and proved that it is necessary to take preventive dust measures.

PREVENTIVE MEASURES

We have investigated and experimented in preventive dust measures of township factories in Liaoning Province for several years. Considering the difficulty of funds and low

level of techniques in these industries, we propose that the following two types of preventive dust measures can be taken.

Hydraulic Production

It is appropriate for highly hydrophobic and possible wet operating mineral production and has advantages of equipment, convenient simple administration and reliable effectiveness. It is very useful for township factories. To date, there are two sets of hydraulic production equipment spread in our province.

Closed Dry-Production

It is suitable for the mineral production which doesn't fit hydraulic operation and suitable in the areas where the water sources are poor. In this situation closed and ventilated dust-proof measures can be carried out.

This small closed-ventilated dustproof system reduced the dust concentration from 289.0 mg/m³ to 9.9 mg/m³. The measure has the advantage of less cost and obvious effectiveness. It is also appropriate to expend the measure in town enterprise

TECHNICAL GUIDANCE

At present, in township industries there are generally no specific technologists who know ventilation. So it is extremely necessary to provide concrete technical guidance and to teach some labour hygiene professionals and technicians for these township factories

Also, today's young doctors engaged in this field lack the knowledge of industrial ventilation and the experience of work, therefore for them to have some studies in industrial ventilation is very useful and necessary for their directing and supervising dust prevention situations. In our province the study class of "ventilation removing dust" or of "evaluating effectiveness of dust-proof equipments" is held every two or three years. Its effect is very obvious.

STRENGTHEN MANAGEMENT

We think that the management system of township industries is quite different from that of state industries. Therefore we should supervise and manage the township industries in labour hygiene in a different way. Much attention should be paid to the following items:

1. The departments responsible in health, in labour job and in environmental protection should match with each

other well. The cooperation among them is the necessary condition for pushing labour hygiene, safety, and environmental protection of township industries forward. The problems existing in these areas need to be planned and unified with due consideration for all concerned and tackled in a comprehensive way. It is supported by the facts that the situation is getting better wherever cooperation is better

2. The key for us to develop the labour hygiene work in township industries is relying on all stages of the government and the departments responsible for it. For example, we can supervise and urge the work, give directions, run study classes, and make programmes, together with the concerned departments.
3. The legal systems must be strengthened. Suel Zhong County has more than 10 crushing mills. Thee county government has made three decisions for the production of crushing mills. They are:

- Hydro-production is required;
- The closed production is required where hydro-production meets big problems;
- Factories could be allowed to go into production only if they have been checked and accepted by epidemic prevention station in county and labour bureau.

Due to these decisions the dust concentration has been kept on a lower level for many users. The government in Janpin County also promulgated "Mine administration regulations." Two of them are emphasized.

As a result, the county government has spread simple and effective preventive dust facilities within one year in 12 perlite mines. These "decisions" and "regulations" are promulgated by the county governments local legality. The only way to guarantee the cardinal interests of the people is to strengthen the legal system and administer strictly.

STUDY OF FIBROGENIC EFFECT OF VERMICULITE DUST ON RAT LUNG

LIU ZHANYUAN • Fang Yuxiang • Yie Fengting • Xiao Xingyuan

Liaoning Institute of Labour Hygiene, P.R. China

INTRODUCTION

Vermiculite is a water-bearing aluminum silicate with iron and magnesium. Its size expands after it is heated. Expansive vermiculite can be used for heat preservation insulation, sound insulation, fire-proofing, antibiosis, acid-proofing, etc. The reports are few on whether vermiculite dust can cause the fibrose of the lung.¹⁻³ In order to search into the fibrogenic effect of vermiculite dust, the study of vermiculite dust on animals has been made as follows.

MATERIALS AND METHODS

Dust used for experiment is obtained from vermiculite mine of Qingyuan, and quartz dust used for control is obtained from sandstone mine of Haicheng. The dust was baked and ground into powder in which the dust size of $\leq 5 \mu\text{m}$ is more than 95%. The content of free silica is 1.96% in the vermiculite dust and 93.8% in the quartz dust.

54 male rats which were of age were divided randomly into three groups. In one of these groups 50 mg of the vermiculite dust was injected intratracheally into each rat and the other two groups were given injection of normal saline or quartz dust in the same way. 1, 3, 6, 9 and 12 months after the injection these rats were killed in batches. The tissue sections of the rats lungs were dyed in HE, foot or VG. The classified criteria of pathology referred to those of experimental silicosis.⁴

RESULTS

Naked Eye Observation

Quartz Group. One month after injecting the dust the lymph nodes of hilus of the lung are the same size as small peas; the surface of the lung is smooth and the quality of the lung is soft. After 12 months the lymph nodes of hilus of the lung are the same size as broad beans, their quality are hard, and the spread, or piecewise spots, were found in the surface of the lung as well as the quality of the spots was hard.

Saline Group. 9 months after the injection, the confined emphysema appeared in some lungs.

Vermiculite Group. One month after injecting the dust the lymph nodes of hilus of the lung are also the same size as small peas and are ochreous; the ochreous spots were seen in the surface of the lung and the lung tissue is soft and sprung. After 9 months the confined emphysema appeared in the lung

Microscopy

Quartz Group. One month after injecting the dust the cell nodes were found in the lymph nodes of hilus of the lung and the lung tissue; after 9 months the cell and fiber nodes appeared; after 12 months the fiber nodes were seen.

Saline Group. The dust response was not shown in the lung throughout the experiment.

Vermiculite Group. One month after injecting the dust, the cell nodes which were of all sizes appeared in the lung tissue. In these nodes there were a lot of the dust particles and epithelium-like cells (23 HE). The proliferation of reticular fiber was found in the nodes and a little collagenous fibers appeared in some nodes (12 VG). Around the nodes there was increased volume widened interval and thickened wall of the alveoli. The proliferation of the epithelium cells was seen in some bronchi and there was a great deal of secretion in their cavities. After 3 months the collagenous fibers were found in the nodes (19 VG) and the confined emphysema appeared around the nodes. After 6(37VG)~12(6HE, VG) months the node-like changes were still seen in the lung. There are a little collagenous fibers, a lot of reticular fibers and spread dust particles in the nodes. The confined emphysema were shown round the nodes. The proliferation of collagenous fiber appeared in the intervals of the alveoli and around various bronchi as well as small blood vessels after 12 months

Biochemical Analyses

The collagen content of the whole lung in each group is shown in Table I and Figure 1.

DISCUSSION

The fibrogenic effect of various silicate dust on the lung is quite complex, and it is a wide field in the study of pneumoconiosis etiology. In the group of vermiculite dust of this experiment one month after injecting the dust, the thinner fibers which were dyed in red were found in the cell nodes; after 3 months little recognizable fibers of collagen were seen in the nodes and the intervals of the alveoli which were dyed in VG. These changes are rare in other silicate dusts. After 6~12 months the collagen fibers were still shown but they differ from the typical silicosis-like changes in amount and distributive scope of the nidus and component change in the node. The results of pathologic observation is in agreement with the result of collagen content of

Table I
Collagen Content of Whole Lung in Each Group (mg/whole lung)

Observation Term (month)	1		3		6		9		12	
	N	\bar{X}	N	\bar{X}	N	\bar{X}	N	\bar{X}	N	\bar{X}
Saline Group	2	32.4	2	28.8	2	39.2	2	34.4	2	63.0
Quartz Group	2	35.7	2	38.5	2	75.7	2	116.5	2	239.8
Vermiculite Group	2	44.4	2	55.1	2	94.1	2	88.0	2	106.5

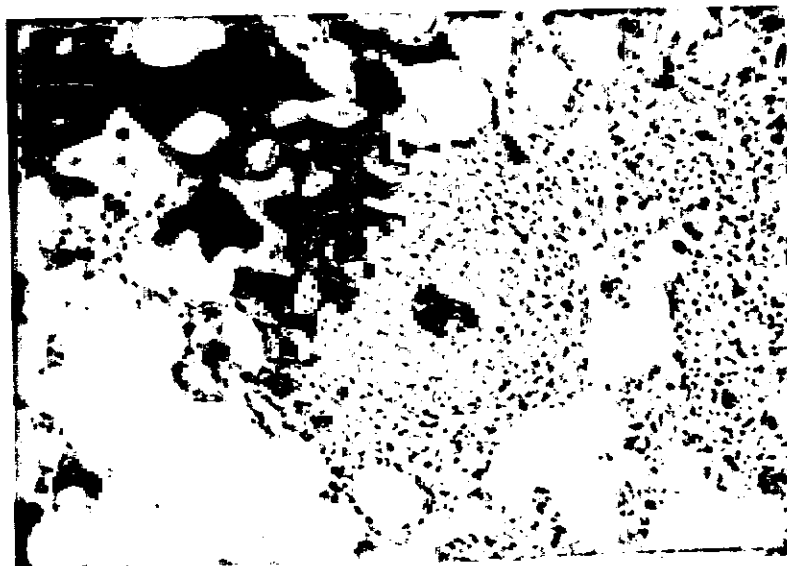

Vermiculite (One month) 23 HE 6.7×10

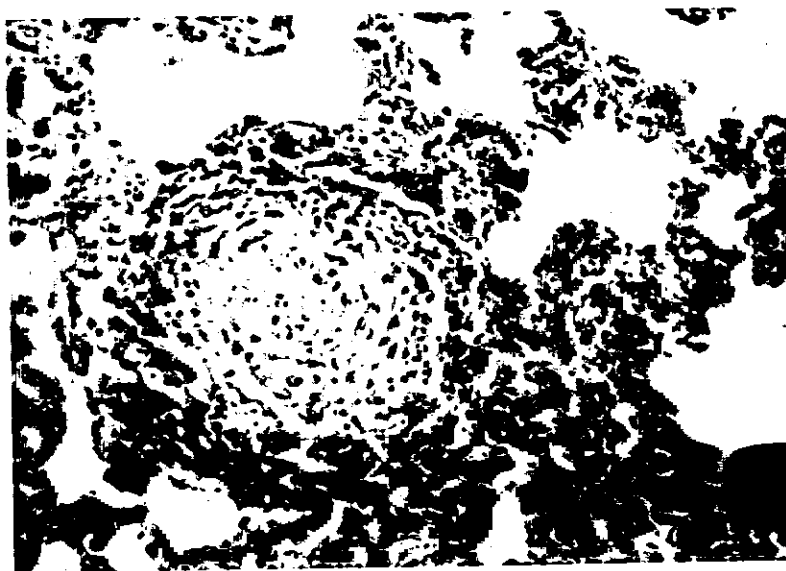

Vermiculite (Three months) 19 VG 6.7×10

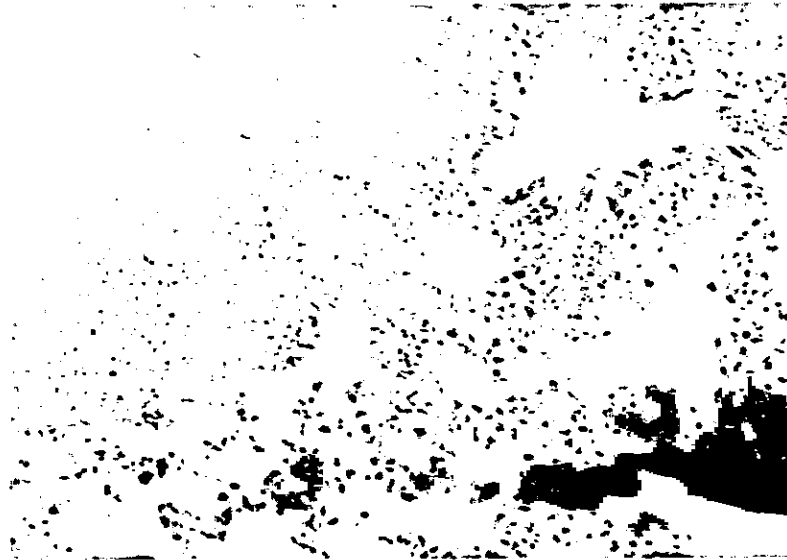

Vermiculite (Nine months) 35 HE 6.7×10

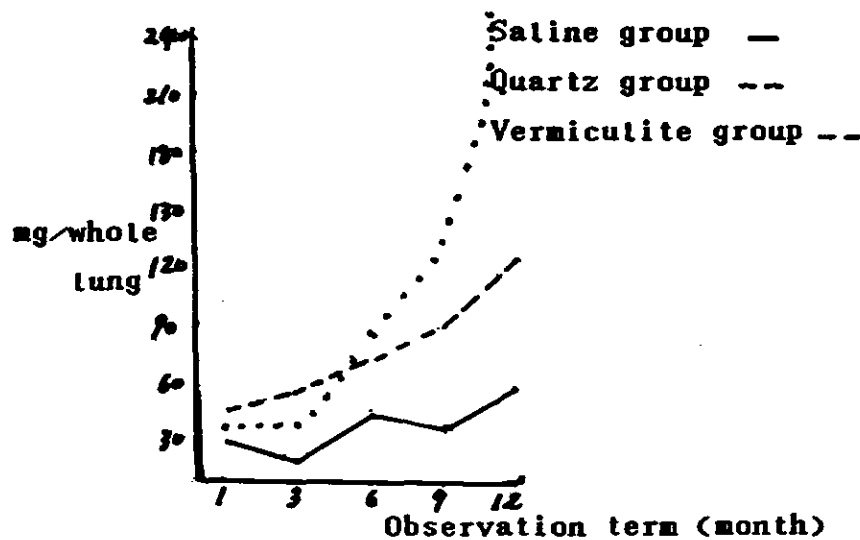

Figure 1. The change of the collagen content of the whole lung in each group.

whole lung. It is indicated that the slight fibrogenic effect on the rat lung is caused by the vermiculite dust.

CONCLUSION

50 mg of the vermiculite dust was injected intratracheally into each rat and after 1 ~ 12 months the pathologic observation and the analysis of collagen content of whole lung were made. The author indicated that the slight fibrogenic effect on the rat lung was caused by the vermiculite dust. The progress of the effect was slower and milder than that of the quartz group and the typical silicosis-like change was not seen.

REFERENCES

1. Henan Institute of Occupational Diseases, et al. Observation of Fibrogenic Effect of Vermiculite Dust, National Symposium on Pneumoconiosis Etiology, P R China 1982.
2. Wang Dexuan, et al. Investigative Report of Vermiculite Pneumoconiosis, Symposium of Third National Congress of Industrial Hygiene and Occupation Diseases, Vol 1, p. 44. Edited by Chinese Medical Association, 1983.
3. Lockey, J.E. et al.: Pulmonary Changes After Exposure to Vermiculite Contaminated with Fibrous Tremolite, *Am. Rev. Respir. Dis.* 129:952-8, 1984.
4. Liang Shurong, et al.: Pathologic Atlas of Pneumoconiosis 1st ed, 1981, p. 39, People's Medical Publishing House, Beijing.

STUDY ON DUST HAZARDS AND PREVENTIVE MEASURES IN MODERN LARGE SCALE PETROCHEMICAL ENTERPRISES

LIU ZHANYUAN • Xiao Xingyuan • Fang Yuxiang

Liaoning Institute of Labour Hygiene, P.R. China

Presently, it is reported at home and abroad, whether there is harm of dusts in modern large petrochemical industries. Our country's petrochemical industries will develop greatly with the vigorous development of our country's oil resources. We had found the problem of dust pollution in processes when testing in a chemical synthetic fibre company before it went into operation. In order to look into dust hazards and preventive measures, we had made investigations and experiments on the dust hazards of this company's polythene, polypropylene and nylon-66-salt, etc., three workshops, from 1983 through 1986.

LABOUR HYGIENIC INVESTIGATION

That company is a new large petrochemical synthetic fibre cooperation company. Major productive equipment was all introduced from abroad. Polythene, polypropylene and nylon-66-salt were put into production in 1981. Dust concentration is relatively high in the air of polluted spot by dust, when adding auxiliary dosage in stable post of polythene 3.4-619.3 mg/m³, adding auxiliary dosage in stable post of polypropylene 0.7-67.5 mg/m³, putting them in mother feed jar 3.4-13.3 mg/m³, at the head of a continuously mixing machine, 2.6-78.8 mg/m³; in front of the packer of nylon-66-salt 48.7-157.3 mg/m³.

The free silica content in three dusts have not been detected by mini-X-ray diffractometer. Those (their dispersities are less than 5 μm) are up to 84.5%-99% by using Glyn's subsidence.

A HEALTH CHECKUP OF DUST EXPOSED WORKERS

We checked about 600 workers for dust exposure in three workshops. Other workers had been found with special changes; besides, these workers of nylon-66-salt had been found to have symptoms of conjunctive stimulate.

ANIMAL EXPERIMENTS

We divided randomly wistar 250 rats with weight 170-210 mg into polythene, polypropylene, nylon-66-salt, quartz control and physiological salt water control etc., into five groups. 50 mg/ml dust mixed-liquid made by polythene, polypropylene was poured into trachea one time. Nylon-66-salt with simulations scene condition through trachea was spouted to lungs 50 mg, observed a year and

half. We observed pathological change and measured content of collagen protein of total lungs. Result of polythene, polypropylene has a light fibering effect; fibering of polypropylenes is more than one of polythene; fibering affect of nylon-96-salt dust is not evident.

POISON TEST OF MACROPHAGUS

We chose New Zealand rabbits with weight of 2-3 kg and killed them by bloodletting on abdomen aorta, collected macrophagus of pulmonary alveolus for training by Myrivk's method. We classified polythene, polypropylene nylon-66-salt, quartz and control into five groups by observing colouration rate of macrophagus and vitality of lactate dehydrogenase. Result is that all of three dusts have some effect

DISCUSSION

Through investigations of three workshops, it is denoted that there are problems of dust pollution in modern large petrochemical industries. Major cause is irrational productive technology and defects in equipment. Stable post of productive route of polythene, polypropylene, due to man hand-work, adding auxilliary dosage, brought about an opening operation in continual production. Productive route of polypropylene is conveyed by mother feed jar after adding auxiliary dosage. Nylon-66-salt after water comes off dried by air flow in carrying pipe, due to shortage of heat preservation on separate equipment; it easily coagulates in it. Workers were compelled to heat equipment frequently or to add vibration installation on equipment, having to put original air tight tie into soft tie, which resulted in destruction of air tightness of equipment. Next is short of necessary ventilator protective equipment

Results of experiments show that polythene, polypropylene dusts all have tight fibering effect on lungs of rats and Nylon-66-salt dusts have certain injury to trachea of rats. Therefore it is considered that long-term exposure of workers to the above mentioned dusts of high-concentration have affected workers' health.

According to results of spot investigations, it is considered that to solve dust hazards in the above-mentioned production process, one needs to eliminate opening productive links and to realize through air tightness products, not to ignore needful ventilation dust-proof equipment at the same time.

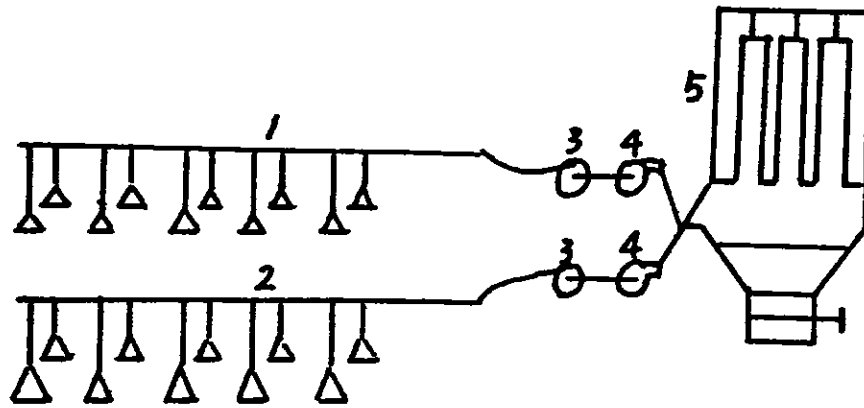

Figure 1. A ventilated dust-proof and dust-removing system in the perlite mine.
1-2. ventilating pipes
3. cyclone dust remover
4. ventilator
5. simple cloth pocket dust changer

DUST ARRESTER (DA)

DR. J. K. SINHA

Head, Environmental Pollution and Occupational Health Division
Central Mining Research Station
(CSIR), Dhanbad, Bihar, India Pin-826 001

ABSTRACT

DUST ARRESTER—It is a device, designed and developed by CMRS to collect fine dust generated during large diameter deep hole drilling in open cast coal and metal mines. The device does not use any extra energy apart from the energy associated with the dust particles which are coming out from the drill hole. The dust Arrester is placed at the drilling point and the drill rod with the drill bit passes through it. It has no exhaust fan, no motor or any moving parts. The dust collection efficiency of the DA varies from 95% to over 99%.

A summary of the results of the tests carried out in various rocks in open cast mines is given below (Midget Impinger was used).

Rock type	Drill Dia.	Airborne Dust Concentrations in ppcc.		
		without DA	with DA	Dust arrested by DA
Coal—I	100mm	11,212	240	97.8%
Coal—II	100mm	2,385	109	95.4%
Stone OB-I	100mm	17,745	333	98.1%
Stone OB-II	150mm	4,653	198	95.7%
Iron Ore-I	150mm	71,327	188	99.7%
Iron Ore-II	150mm	9,482	183	98.1%

No Paper provided.

HANDLING OF MINERAL WOOL WITHIN THE CONSTRUCTION INDUSTRY

BJÖRN LINDBLAD, et al.

The Construction Industry's Organization for Working Environment
Safety and Health, Bygghälsan, Sweden

The results of earlier fibre measurements show that the concentration of fibres (respirable fibres) in the air during the normal handling of mineral wool is relatively low compared with the current Swedish hygienic limit value (1 f/ml).^{1,2} Symptoms in the form of skin irritation are well known to occur in connection with the handling of mineral wool products.

Medical studies have shown that there is a high likelihood that "coarse fibres", cause skin irritation through mechanical action.

The project "Handling of mineral wool within the construction industry" has examined the possibilities of improving handling in such a manner that coarse fibres are emitted as little as possible and of reducing exposure by finding handling methods where the time of direct contact with mineral wool products is sharply reduced.

The project has also included attempts to measure coarse fibres using new methods in order to improve the possibilities of evaluating the effectiveness of adopted changes in methods and products.

The project has had two main components:

1. Studies of handling
2. Product development—measurement method development

Studies of Handling

The studies have been carried out at factories, warehouses and during transports. Furthermore, studies have been conducted at wholesalers and on building sites. The studies conducted during the different handling phases have endeavoured to concentrate on the most common mineral wool products.

The results of the studies show that manual handling is considerably reduced when the products are delivered in crates or on pallets. The manufacturers are currently working on developing rational delivery systems for reducing manual handling. Studies have been made of special cutting stations and cutting table for mineral wool.

The study has shown that large quantities of fibre dust are stirred up during cleanup and collection of mineral wool waste. During insulating work with mineral wool, special containers, sacks or the like should be available for collecting mineral wool waste.

The report gives examples of hints and ideas to limit the spread of dust from mineral wool products and to obtain more rational mineral wool handling out on the building sites.

Measurement Method Development

Experiments with better methods for measuring coarse fibres have been carried out within the framework of the project. "The surface limitation method," where fibre dust was vacuumed up from ten areas, about 50 mm in diameter, on the floor immediately after the end of the insulation work on the test premises, can probably be developed with a slightly modified sampling system. The experimental series must also be large enough to obtain a statistically useful body of data for processing. Studies of the behaviour of fibres in the air have been documented using a video camera and strong lighting. The method, which originally comes from the U.K., has attracted the interest of the National Board of Occupational Safety and Health and may in the long run be an interesting aid in assessing fibre emissions during insulation work.

Product Development

In cooperation with the manufacturers, experiments have been conducted involving "preparation" of products aimed at binding loose fibres. The results have been interesting, although many problems remain to be solved. In the experiments, vacuumed mineral wool products have emitted lower concentrations of airborne fibres than non-vacuumed products. The values of vacuuming should be evaluated in relation to other handling of the different products.

REFERENCES

1. Hallin, N.: Mineral wool dust in construction sites. *The Construction Industry's Organization for Working Environment, Safety and Health, Bygghälsan, Sweden, Report (1981-09-01)*.
2. *Synthetic Inorganic Fibres AFS 1982:4*. National Swedish Board of Occupational Safety and Health, Sweden (1982).

MECHANISM OF THE DAMAGE TO AM BY SILICA AND ANTI-CYTOTOXIC EFFECTS OF ALUMINUM CITRATE: ULTRASTRUCTURAL STUDY

HONG YIN • Shijie Liu

School of Public Health, Beijing Medical University, Beijing, China

ABSTRACT

The mechanism of the damage induced by silica to alveolar macrophages (AM) was investigated at the ultrastructural level. The experimental results with TEM and SEM show that apparently injurious alterations occur for AM exposed to a higher dose of silica in a short time, such as the swelling of mitochondria, the dilating of endoplasmic reticulum and the changes on the surfaces of cells. Further, plasma membrane Mg^{2+} -ATPase and freeze-fracture observation indicates that the decrease of the reaction products of the enzyme on the cell membranes and aggregation of intramembranous particles on two halves of the membrane of AM can be seen in those cells without evident morphological changes, suggesting that the damage induced by silica to the plasma membrane of AM may be an important key in the initiating of the cytotoxic process. In addition, the evidences from the phagocytosis-inhibited experiment with cytochalasin B (CB) proves that the inhibition of phagocytosis with CB cannot prevent AM against being damaged by silica, indicating that the cytotoxicity by silica may be independent of the phagocytosing of the silica particles into the cells and the plasma membrane may be primary foci of the damage. And, on the other hand, AC-Pase cytochemistry shows that the reaction products of the enzyme have a similar diffusing distribution throughout the cytoplasm within both of cells with and without CB, demonstrating that the leaking of lysosome enzymes into the cytoplasm may be, at least under some of conditions, a secondary event with the disturbance of metabolism of cells following the injury to the plasma membrane. Finally, the protective effects of aluminum citrate on AM are also proved at the ultrastructural level. A possible mechanism of the protection is that silica particle combined with aluminum element on its surface has lower affinity to the cell membrane and therefore lessens the cytotoxicity of silica.

No Paper provided.

**MINI-CYCLONES "TCR" IN NYLON AND IN ALUMINUM:
THE INFLUENCE OF ELECTROSTATIC CHARGES ON THE EFFICIENCY
OF THE COLLECTING OF RESPIRABLE DUST**

G. RIPANUCCI

INAIL, Rome, Italy

ABSTRACT

For evaluation of the existence of risk to professionals (workers) exposed to fiber dust, it is necessary to resort to the collecting of the respirable fraction of the dust in suspension at the work posts of a variety of occupations.

A mini-cyclone, investigated at the Italian establishment TCR TECORA S.r.l., has been realized in dual fashion, in nylon and in aluminum, to examine the influence of electrostatic charges on the effectiveness of collecting dust.

Like the well-known cyclone in nylon at ten millimeters in diameter of ACGIH, the cyclone "TCR" also works at weak intensity (1.5-2.0 l/l'): it is distinguished by the dimension of the opening for the air, by the assembly of the group cyclone filter portal, and by the connection (of the rigid type) between the two principal elements of the cyclone.

We will collate and discuss the results of the measures effectuated, in parallel, by the two TCR examples and the the 10mm, nylon cyclone (DORR-OLIVER Model).

No Paper provided.

STUDY ON SUPPRESSION OF SOLUBLE ALUMINUM AEROSOLS ON QUARTZ-INDUCED CYTOTOXICITY —Combined Effects of Both Aerosols in an Artificial Dust Atmosphere

CHEN JIN, M.S. • Shijie Liu, M.D.

Department of Occupational Health, Beijing Medical University
School of Public Health, Beijing, P.R. China

INTRODUCTION

Since 1930's it has been noted that aluminum (Al) and its compounds could prevent and treat silicosis. A number of studies have shown that Al could resist the cytotoxicity of SiO₂ particles on macrophages and erythrocytes, and suppress or lessen quartz-induced pulmonary fibrosis.^{1-4,6,9,12,18} More recently, it has been found that the mechanism of the effects of Al was the combination of it with SiO₂ particles, which altered some properties of the particle surface, so leading to the decrease of pathogenic activity of SiO₂.^{4,18} And the charges on SiO₂ particles were greatly reduced after the mineral particles were combined with Al, which was quite valuable to aggregation and dropping SiO₂ dusts. Consequently, if Al is used in dust workplace, such as spraying aqueous solution of aluminum compound or adding soluble aluminum into the water for dropping dusts from which the soluble aluminum aerosols are generated and probably combined with the SiO₂ dusts in air and/or inside lungs before or after the dusts are inspired into the worker's respiratory passage, it will give play to the dual effects on both resistance against the pathogenicity of SiO₂ and dripping the SiO₂ dusts in working atmosphere. It is possible to explore a new way to treat dusts in our industries and mines to prevent the development of silicosis.

The present study made an attempt to demonstrate whether or not the soluble aluminum aerosols could combine with SiO₂ particles in the atmosphere, and if they could suppress or lessen the cytotoxicity of the minerals on guinea pig alveolar macrophages and rat erythrocytes.

MATERIALS AND METHODS

Development of a Dynamic Inhalation Exposure System and Collection of SiO₂ Particles Combined with AIAs or DWAs

A dynamic inhalation exposure system was designed and developed to simulate an atmosphere interacting of both aerosols—SiO₂ particles and soluble aluminum aerosols (AIAs) or deionized water aerosols (DWAs). SiO₂ dusts generated by a dust generator (modified F-710 Electromagnetic feeder made in China Jiujiang) were conveyed into the exposure chamber (made of polymethyl methacrylate, 0.8M³ in volume) of the system to form the average concentration of 200mg SiO₂/M³. AIAs or DWAs, on the other hand, nebulized by an ultrasonic nebulizer

(JWC-2A Transistor Ultrasonic Nebulizer made in China Anshan, 0.5–10µm in aerosol diameter) were sprayed into the chamber from another inlet. In the exposure chamber both aerosols interacted on each other, and SiO₂ particles combined with and/or without AIAs or DWAs were sampled on a microfilter (0.45 µm in pore size, made in China Beijing) by WY-1 cascade impactor (7 catch stages, made in Chinese Academy of Preventive Medicine),¹¹ on the basis of which following experiments were done.

Measurement of Aluminum Combined on SiO₂ Particles

The contents of Al and SiO₂ in the sample on the microfilter were directly analyzed and measured by thin film X-ray fluorescence (XRF), based on modification of method of Cui et al.,⁷ with PW-1400 X-Ray Fluorescence Meter (made in Philip Inc.) from which the amounts of Al combined on SiO₂ particles were calculated and expressed in µg Al per cm² specific area of SiO₂, i.e., µgAl/cm² SiO₂. The specific area was calculated from the diameter and density of SiO₂ particles.¹⁶

Cytotoxicity Examination of the SiO₂ Particles Combined with AIAs

Using hemolysis assay and macrophage viability test monitored in vitro the cytotoxicity of AIAs—or DWAs—combined SiO₂ particle samples collected from the 5th stage microfilter of the Impactor, represented by antihemolysis rate (AHR) and macrophage viability index (MVI). The former was based on the hemolysis assay system previously described by Hefner et al.,¹⁰ Briefly, whole blood was taken from rat aorta abdominalis, washed 3 times in normal salt (NS) by centrifugation at 1500 rpm for 10 min., and the pellets, all of which are almost erythrocytes (RBC), were resuspended in NS to 20% (v/v). 1 mg SiO₂ or SiO₂-Al sample was added to 3 ml or the 2% RBC suspension, and the mixture incubated in 37°C water bath for 30 min and gently shook every 5 min. At the end of incubation, with centrifugating the mixtures the supernatants was measured for optical density (OD) at 420nm wavelength. Antihemolysis rate (AHR) was calculated from below formula:

$$\frac{(\text{HR of SiO}_2\text{-H}_2\text{O}) - (\text{HR of SiO}_2\text{-Al})}{\text{HR of SiO}_2\text{-H}_2\text{O}} \times 100\%$$

where HR (hemolysis rate)

$$= \frac{\text{OD of SiO}_2\text{-Al group}}{\text{OD of whole hemolysis group}} \times 100\%$$

MVI is complex indicators of damage effects of SiO₂ particles on macrophages, including rate of macrophage viability (RMV), intracellular K⁺ contents and lactate dehydrogenase (LDH) activity in the conditioned medium of macrophages cultured with the SiO₂ samples. Alveolar macrophages (7×10⁶/ml) harvested from male guinea pig lungs with bronchopulmonary lavage as described earlier⁹ were incubated with 150μg/mg SiO₂ (SiO₂-Al or SiO₂-H₂O samples) or normal salt (NS, as negative control) in medium RPMI1640 at 37°C in 5% CO₂-95% air for 4 hours, RMV(%) was assayed by trypan blue exclusion test, intracellular K⁺ contents of macrophages by Flame Atomic Absorption Spectroscopy and LDH activity in the conditioned medium by a colorimetric process.^{14,18} According to these parameters above, MVI was obtained from the formula:

$$\left(\frac{\text{RMV in SiO}_2\text{-Al group}}{\text{RMV in NS group}} + \frac{\text{K}^+ \text{ in SiO}_2\text{-Al group}}{\text{K}^+ \text{ in NS group}} \frac{\text{LDH in NS group}}{\text{LDH in SiO}_2\text{-Al group}} \right) \times 300\%$$

and the rate of AIA-suppressed toxicity of SiO₂ dusts to macrophages (RAST) was calculated from:

$$\frac{(\text{MVI in SiO}_2\text{-Al}) - (\text{MVI in SiO}_2\text{-H}_2\text{O})}{(\text{MVI in NS}) - (\text{MVI in SiO}_2\text{-H}_2\text{O})} \times 100\%$$

RESULTS AND DISCUSSIONS

Combination of Soluble Aluminum Aerosols with SiO₂ Particles

1) *The amounts of Al combined on SiO₂ particles at nebulization with various aluminum compounds.* Four soluble aluminum compounds, Al-I, Al-II, Al-III and Al-IV (synthesized and supplied by the Beijing Medical University School of Pharmacy) were prepared to 0.5mgAl/mg solution in deionized water. Experiments were respectively done with each of them under the consistent conditions such as nebulizing, sampling and measuring described above. As shown in Figure 1, all but Al-I aqueous solution were found to significantly increase the amounts of Al combined on

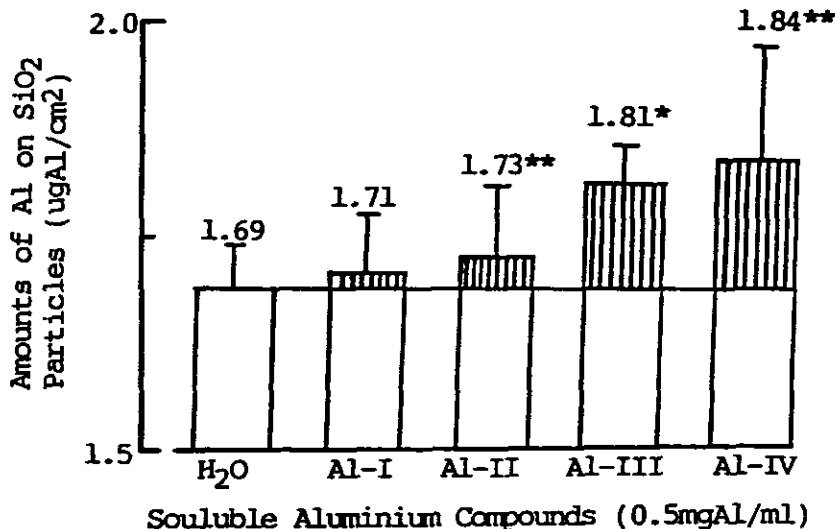

Figure 1. The amounts of Al combined on SiO₂ particles at nebulization using four soluble aluminum compounds (Al-I, Al-II, Al-III and Al-IV aqueous solution) and deionized water (H₂O). Mass Mean Aerodynamic Diameter (MMAD) of SiO₂ particles in these samples was 5.14μm. *P<0.01; **P<0.05 t-test with H₂O group; expresses the net amounts of Al combined on SiO₂ particles.

SiO₂ particles as compared with the DWAs-sprayed SiO₂ samples. The net amounts of Al on SiO₂ particles ranged from 0.09 to 0.15 μgAl/cm² SiO₂. Although the amounts of Al at the Al-III-nebulized aerosols group were situated between Al-II and Al-IV, considering that Al-III was in great resource and easy to be produced in our country, our investigations were mainly done on the interaction of Al-III aqueous solution aerosols with SiO₂ dusts as follows.

2) *Combination of SiO₂ particles with the AIAs nebulized with the various concentrations of Al-III aqueous solution.* Al-III aqueous solution was diluted into 0.1, 0.3, 0.5 and 1.0 mgAl/ml with deionized water, and respectively nebulized into the exposure chamber with SiO₂ dusts at same conditions. Significant linearity between the Al-III aqueous solution concentrations and the amounts of Al combined on SiO₂ particles was observed in Figure 2, i.e., the amounts of Al on SiO₂ particles increased with increasing the concentrations of Al-III solution. It was noted that in the presence of nebulization by the lower concentrations of Al-III solution the amounts of Al on SiO₂ particles was 0.16 ± 0.03 μgAl/cm² SiO₂ and reached an effective level reducing pathogenicity of the mineral dusts, as the previous experiment in which the interaction of Al with SiO₂ was in test tube had suggested that while the amounts of Al on SiO₂ were 0.15 μgAl/cm² or so, the cytotoxicity of SiO₂ was obviously suppressed. When the SiO₂ samples combined with AIAs or DWAs were washed 4 to 5 times in deionized water by centrifugation at 4000 rpm for 20 min., respectively resuspended and filtered on microfilter by suction for XRF

analysis, it was found that amounts of Al on the post-washed SiO₂ particles were yet more enough (data not shown) to lessen the SiO₂-induced cytotoxicity on the basis 4 of preliminary experiments in test tube.⁴ This suggested that the combination of AIAs with SiO₂ particles was quite firm and relatively stable.

3) *Combination of various SiO₂ dusts in diameter with AIAs.* With nebulizing 0.5mgAl/ml of Al-III aqueous solution into the SiO₂ dust atmosphere of the exposure chamber, the SiO₂ samples were collected on four stage microfilters from 2.54 to 6.97 μm MMAD (2.54, 3.68, 5.14 and 6.97 μm MMAD, respectively) by the cascade impactor (10L/min sampling flow rate), and measured by XRF to calculate the amounts of Al combined on various SiO₂ particles in diameter. The results shown that the higher the SiO₂ particle-size distribution was, i.e. the smaller SiO₂ particles, the more AIAs could be combined with them (Figure 3). The net amounts of Al on the 2.54 μm SiO₂ MMAD were 9 times as many as that on the 6.97 μm SiO₂. In accordance with the deposition curve of SiO₂ particles in lungs, the 2 to 3 μm MMAD SiO₂ particles were of maximum deposition in lungs.¹⁷ Therefore, no doubt will the AIAs in dusty workplace be much more significant as a preventive measure to silicosis.

Anti-cytotoxic Effect of Soluble Aluminum Aerosols on SiO₂ Dusts

To estimate the preventive effects of AIAs on silicosis, the changes in cytotoxic effects (AHR and MVI) of the SiO₂

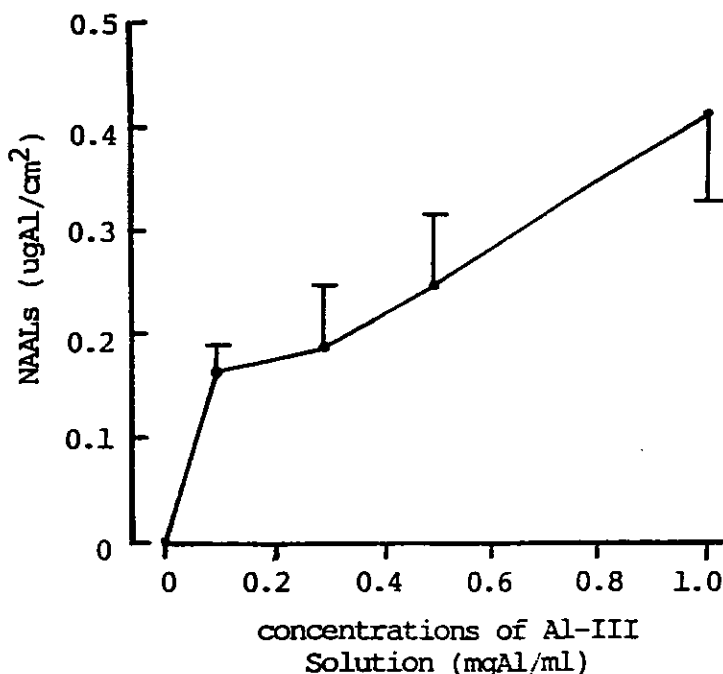

Figure 2. The combination of SiO₂ dusts with AIAs nebulized by various concentrations (0.1, 0.3, 0.5 and 1.0mgAl/ml) of Al-III aqueous solution. NAALs represents the net amounts of Al combined on SiO₂ particles, i.e., the amounts of Al on AIAs-treated SiO₂ minus the ones on DWAs-treated SiO₂. The number of samples was 4 per group.

particles combined with aerosols of Al-III aqueous solution of various concentrations on guinea pig alveolar macrophages and rat erythrocytes were examined, which is rapid, sensitive and common marks to test cytotoxicity of mineral dusts and also an important evidence to reflect pathogenicity of them.⁵ The greater AHR and MVI are, the lower the cytotoxicity of SiO₂ particles is and the more effectively the AIAs could resist SiO₂-induced pulmonary damage.

As seen in Figure 4, the AIAs-combined SiO₂ particles greatly increased the AHR and MVI with statistical significance as compared to control group. To some extent the increases were correlated with the amounts of Al on SiO₂. When the amount of Al was $0.18 \pm 0.06 \mu\text{gAl}/\text{cm}^2$ (in the nebulizing group of 0.3mgAl/ml Al-III aqueous solution), AHR and MVI reached maximum level, 66.23% and 64.3%, respectively. At nebulization with the lower concentration

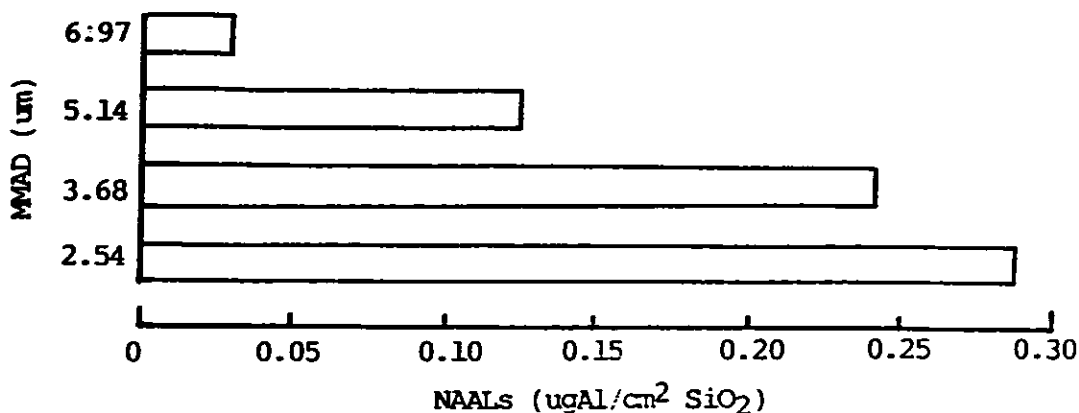

Figure 3. The net amounts of Al (NAALs) combined on the SiO₂ particles of various diameter (MMAD 2.54 to 6.97µm) sampled by cascade impactor (10L/min sampling flow rate).

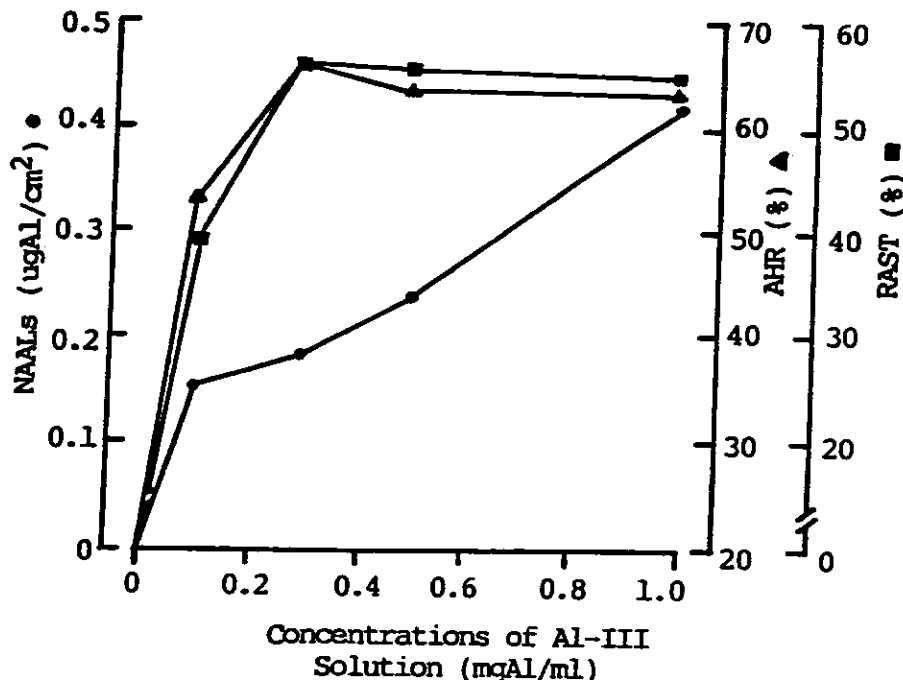

Figure 4. The suppressing effects of soluble aluminum aerosols on SiO₂-induced cytotoxicity to macrophages and erythrocytes. NAALs: net amounts of Al combined on SiO₂ particles; AHR: antihemolysis rate; RAST: rate of AIAs-suppressed toxicity of SiO₂ dusts to macrophages.

of Al-III aqueous solution (0.1mgAl), the cytotoxicity of the SiO₂ particles was also suppressed by more than 40% (AHR by 48.32% and RAST by 52.1%).

CONCLUSIONS

The experimental results indicated that AIAs could not only stably combine with SiO₂ dusts in an atmosphere, but also effectively suppress the cytotoxicity of the minerals of macrophages and erythrocytes, which is consistent with the previous investigations in water system.^{4,18} Although the present study did not examine the change of surface charges of SiO₂ particles, according to the preliminary experiments in which the surface charges of SiO₂ particles significantly decreased once the SiO₂ particles were combined with Al, it may be speculated that AIAs could reduce the charges of SiO₂ surface and promote aggregating and dropping of the SiO₂ particles in a dusty atmosphere.

It must be pointed out that in this study the AIAs combined with SiO₂ dusts were only involved, but the other AIAs combined without SiO₂ in the air can be inspired into lungs together with SiO₂ dusts and interact with the minerals in respiratory passage, by which the AIAs could in the same way make resistance against the cytotoxicity of SiO₂ particles. Therefore, though in the nebulizing group with 0.1mgAl/ml Al-III aqueous solution the amounts of Al combined on SiO₂ particles and the suppression of Cytotoxicity were not maximum, the effective amounts of Al will greatly increase if it is considered that the AIAs can combine with SiO₂ dusts in respiratory passage. It is suggested that 0.1mgAl/ml Al-III aqueous solution or lower may be suitable for further experiments in lab and dust working sites. However, the optimal dosage of soluble aluminum compounds used in workplace remain to be further experimented.

REFERENCES

1. Begin, R., Masse, S., Rola-Pleszczynski, M., Martel, M., Desmarais, Y., Geoffroy, M., LeBouffant, L., Danniell, H., Martin, J.: Aluminum lactate treatment alters the lung biological activity of quarts. *Exp. Lung Res.* 10(4):385-399 (1986).
2. Begin, R., Masse, S., Sebastien, P., Martel, M., Geoffroy, M., Labbe, J.: Late aluminum therapy reduces the cellular activities of simple silicosis in the sheep model. *J. Leukocyte Bio.* 41:400-406 (1987).
3. Bouffant, L.L., Daniel, H., Martin, J.C.: *Inhaled Particles IV (part D)*, pp. 389-401. Pergamon Press Ltd. (1977).
4. Cao, C.J., Liu, S.J., Lin, K.C.: *The injurious effect of silica and the anti-injurious effect of aluminum citrate on biological membranes*. The Graduate Thesis of M.D. in BMU (1985). (in Chinese)
5. Chamberlain, M., Davies, R., Brown, R.C., Griffiths, D.M.: In vitro tests for the pathogenicity of mineral dusts. *Ann. Occup. Hyg.* 26(1-4):583-592 (1982).
6. Crombie, D.W., Blaisdell, J.L., MacPherson, G.: The treatment of silicosis by aluminum powder. *Canad. Med. Assoc. J.* 50:318-328 (1944).
7. Cui, F.H., Wang, S.L., Pu, S.B.: Analysis of suspended particles in atmosphere with X-ray fluorescence. *Environ. Chem.* 2(3):52-58 (1983). (in Chinese)
8. Dauber, J.H., Daniele, K.R.: Chemotactic activity of guinea pig alveolar macrophages. *Am. Rev. Respir. Dis.* 117:673-684 (1978).
9. Dix, W.B.: Aluminum Powder and silicosis prophylaxis. *Canad. Min. J.* 92(10):35-42 (1971).
10. Hefner, R.E., Jr., Gehring, P.J.: A comparison of the relative rates of hemolytic induced by various fibrogenic and non-fibrogenic particle with washed rat erythrocytes in vitro. *Am. Ind. Hyg. Assoc. J.* 36:734-740 (1975).
11. Liu, G.Q., Wang, Y.S., Chen, M.N., Liu, J., Ma, L.X.: The development of WY-1 cascade impactor for flue pipe. *Environ. Engineering* 5:17-24 (1985). (in Chinese)
12. Liu, S.J., Zou, S.Q.: *Symposium of Studies on Occupational Medicine Vol. III*, pp. 86-97. Dept. of Occup. Med. of BMU, Beijing (1979). (in Chinese)
13. Macnab, G., Harington, J.S.: Hemolytic activity of asbestos and other mineral dust. *Nature* 214:522-523 (1967).
14. Medzihradsky, F., Marks, M.J.: Measures of viability in isolated cells. *Biochem. Med.* 13:164-177 (1975).
15. Skaug, V., Davies, R., Gylseth, B.: In vitro macrophage cytotoxicity of five calcium silicates. *Brit. J. Ind. Med.* 41:116-121 (1984).
16. Tan, T.Y., Liang, F.Z.: *Technology for Industrial Ventilation and Trapping Dusts*, pp. 33-35. Architectural Industry Press of China, Beijing (1984). (in Chinese)
17. Watson, H.H.: Dust sampling to simulate the human lung. *Brit. J. Ind. Med.* 10:93-100 (1953).
18. Zou, T.T., Liu, S.J.: *Studies for prevention of aluminum citrate from cytotoxicity of silica in vitro*. The Graduate Thesis of M.M. in BMU, (1982). (in Chinese)

ACKNOWLEDGEMENT: This work was supported by grant from the Ministry of Labour and Personnel, P.R. China.

PSEUDO-TUMORAL LUNG FORMATIONS FROM SILICA FREE DUSTS

LUCIANO ROMEO • L. Perbellini • P. Apostoli • F. Malesani

Institute of Occupational Medicine, University of Verona, Italy

INTRODUCTION

In our experience we have encountered some workers who exhibited round shaped opacities in their lung suspected as being neoplastic in nature. In certain cases it was possible to exclude malignancy of such lesions, identifying them on the contrary, as the results of prolonged inhalation of silica free dusts at work.

In this work we report four cases exposed to calcium and magnesium salts (as previously stated) and one case of talc exposure, recently observed, who exhibited these types of lesions.⁵

SUBJECTS AND METHODS

Our study was carried out on five patients: four were magnesium and barium hydroxide production workers and one was a natural rubber processing operator. The first four subjects were allocated in the same industry and had done various tasks in two departments:

1. magnesium production employing heat processing (Pidgeon system), using dolomite, ferrosilicon and calcium fluoride as raw materials;
2. barium hydroxide production employing "Soderbergher" furnaces, by use of barium carbonate.

In the first department the environmental dust level was between 1.6 and 71.3 mg/m³ and in the second one from 0.8 to 128 mg/m³.

The four workers between the ages of 43 and 58, had worked in the two departments for long periods (from 17 to 34 years). Their chest X-ray films were very similar and presented coin shaped lesions measuring 1-2 cm in diameter, single in three cases and multiple in one. Only one case was also a pneumoconiosis suspect with reticular shadows. In two workers the coin shaped lesions were found 3-4 years before.

We had suspected the presence of secondary neoplasm of the lung but as it proved impossible to locate the primary site of neoplasm, in spite of accurate investigations, chest X-ray film follow-ups were suggested.

In three of the four subjects the coin lesions remained unchanged at every follow-up for five years. In the fourth subject, after three years, the two shadows originally identified had increased about 30% in diameter reaching a dimension of 3 and 1.5 cm respectively. We therefore proceeded with a toracotomy which permitted removal of a sub-pleural well encapsulated node.

On cryoscopy it was described as: "fibrous wall node with signs of chronic inflammation and a central area of necrosis." The histological examination revealed: "well defined node of lung parenchyma consisting essentially of interwoven and whirl-pool-like collagen fibers, free of identifiable cells, and minute calcified particles. The surface area of the node is rich in fibrocytes, newly formed vessels, clusters of lymphoplasmocytic cells and occasional foreign body multinucleated giant cells."

Mineralogical studies on the node employing X-ray diffraction, neutronic activation, and X-ray fluorescence showed scarce presence of silica and no significant concentrations of any specific metals. The Debye X-ray diffraction revealed this node as being rich in calcium and magnesium diphosphate.

The subjects maintained good health and showed no further lesions of the lung whatsoever on radiological investigations.

The fifth worker, 45 years old, had worked in a department for the processing of natural rubber where according to the requirements for production, dust of talc, mica and fecula were alternatively used.

The results of environmental investigation carried out to determine the type and quality of corpuscular pollution showed a variation of 0.6 and 1.4 mg/m³ of dust concentration.

Microscopic examination of the particles removed revealed that the dust was rich of fibers 1-2 µm in diameter, 80% 10-20 µm in length and 20% less than 10 µm long. Fecula consisted of particles less than 5 µm in diameter which under polarized light had the typical "malta cross" appearance. Lastly, mica consisted of lamellae ranging from 20 to 60 µm in size. No asbestos fibers or silica was found.

The patient gave no history of respiratory or other diseases. All at once, a few days before admission, the subject had slight fever, cough and exertional dyspnoea. The chest X-ray film showed presence of an irregular digitated shadow, 3.5 cm in diameter, at the base of the left lung.

All the various investigations carried out were negative. Between thirty and ninety days after, other coin shaped shadows appeared bilaterally, becoming larger and more numerous, tending to be confluent.

The rapid growth of the lesions in the lung compared to the satisfactory clinical state of the patient, led us to proceed with a toracotomy.

The cryoscopic examination of the heaviest mass which was first localized at the base of the left lung, ruled out any presence of neoplasm.

The histological examination reported: "Lung parenchyma greatly altered by wide-spread granulomatose inflammation consisting of epithelioid cells and numerous foreign body giant cells, containing birefrangent needle-like fibers 1-2 μ m in length and asteroid bodies."

In conclusion the histological diagnosis was "giant cell talc granulomatosis of the lung."

The results of the study made on the material used by the patient at work confirm that the needle-like formations seen in cytoplasm of the giant cells were talc fibers and one may assume that the asteroid bodies were, on the contrary, fecula granules.

The postoperative course was normal and his overall condition improved. In addition, within the following months a slow but constant regression of the shadows was observed and seven months later only rare radiological irregular opacities were seen. Two years later the chest X-ray film was normal apart from the signs of the toracotomy.

DISCUSSION

The description of pseudo-tumoral lung formations from silica free dusts is rare in literature.^{2,4}

Although coin lesions of the lung due to inhalation of calcium and magnesium salts have not been reported, scientific studies have described talc granulomas of the lung and other organs.^{3,5,6,7,8}

With regards to the first four cases we have described among the raw materials used at work, dolomite results the most suspected responsible for round shaped opacities of the lung.¹

The rapid development and progression of talc granulomatosis found in our rubber worker and its disappearance after he stopped work was probably due to reversible flogistic-proliferative tissue reaction, without fibrosis, from talc free of silica or asbestos fibers.

Hence, in the presence of lung lesions, in particular those we have described, it seems beneficial to add to routine clinical and instrumental practice suitably deeper investigation into work history of subjects, possibly including analysis of work environment and raw materials in use.

REFERENCES

1. Anttila, S., Sutinen, S., Paako, P., Finell, B.: Rheumatoid Pneumoconiosis in a Dolomite Worker: A Light and Electron Microscopic, and X-ray Microanalytical Study. *Br. J. Dis. Chest* 78/2:195-200 (1984).
2. Alivisatos, G.P., Pontikakis, A.E., Terzis, B.: Talcosis of Unusually Rapid Development. *Br. J. Ind. Med* 12:43-49 (1955).
3. Brody, A.R., Dwyer, D.M., Vallyathan, N.V., Craighed, J.E.: Elemental Content of Granulomata in Biopsied and Autopsy Lung Tissue. *Am. J. Path.* 86:72 (1977).
4. Cavignaux, A., Fuchs, C.A., Tara, S.: Un Cas de Talcose a Forme Pseudo Tumorale. *Arch. Mal. Prof.* 11:34-39 (1950).
5. D'Andrea, F., Apostoli, P., Chiesa, A., Menestrina, F., Pucchetti, V.: Opacita' Rotonde Polmonari in Lavoratori Addetti alla Produzione di Magnesio: Considerazioni Eziologiche. *Med. Lav.* 2:161-166 (1980).
6. Eisemen B., Seeling M.C.: Talcum Powder Granuloma: a Frequent and Serious Postoperative Complication. *Ann.Surg.* 126:820 (1974).
7. Gordon, B. Mc Donald, D.F.: Talc Granuloma Presenting as a Testicular Mass. *J. Urol.* 118:122 (1977).
8. Tukiainen, P., Nichels, J., Taskinen, E., Nyberg, M.: Pulmonary Granulomatous Reaction: Talc Pneumoconiosis or Chronic Sarcoidosis? *Br. J. Ind. Med.* 41:84-89 (1984).

MINERAL FIBERS AND DUSTS IN THE LUNGS OF SUBJECTS LIVING IN AN URBAN ENVIRONMENT

F. MALCHIODI ALBEDI • L. Paoletti • M. Falchi
• M. P. Carrieri* • A. M. Cassano • G. Donelli

Laboratorio di Ultrastrutture and Laboratorio di

*Epidemiologia e Biostatistica, Istituto Superiore di Sanita'
Viale Regina Elena, 299—00161 Rome, Italy

INTRODUCTION

It is well-known that toxic and carcinogenic substances can be present in the breathable airborne particulate of urban areas and the higher incidence of tumors and chronic obstructive lung diseases, documented in these areas as compared with rural ones, is generally considered to be a consequence of the environmental conditions.³ Recently, the need to better define the carcinogenetic role of atmospheric pollution in comparison with that played by other factors, such as cigarette smoking, has been emphasized.⁴

Here, we have studied mineral particulate from autoptical lungs in a sample of population having lived in Rome area and not occupationally exposed to dusts. Their life-style, in particular their smoke habits, and the quantity and quality of fibers and mineral dusts found in their lungs were correlated.

MATERIALS AND METHODS

Sixty subjects, who had lived in Rome, aging from 15 to 65 years, were selected for this study. Subjects with a history of occupational exposition to mineral dusts or with serious pathologic conditions and drug addicts were excluded. During post-mortem examination, fragments of lung tissue were taken from the upper lobe of right lung.^{1,2} They were mineralized in atomic oxygen plasma. Dry weight was also estimated. Inorganic component was resuspended in deionized water and filtered on 0.45 μ m cellulose membrane filters. Mineral particles were then transferred on copper grids, which had been coated with carbon films. They were observed under a 430 Philips transmission electron microscope, equipped with an energy-dispersive spectrometer for X-ray. Adjacent fragments of lung tissue were fixed in formalin and embedded in paraffin for light microscope observation.

RESULTS

Concentration and Type of Mineral Particulate in the Lungs

Mineral particle concentrations in the lung parenchyma ranged from 0.7×10^5 to 1.7×10^5 particle/mg of dry tissue (Figure 1). Two principal components were found—Silicates and crystalline silica (52%)—Heavy metal oxides and sulfates (48%). The relative percentage of components, however, showed significative differences, since in nearly 12% of sub-

jects the ratio between silicates and metal compounds differed for more than 50% of the average value. Fibrous particles were detected in 16% of subjects. They were generally represented by asbestos fibers (chrysotile and amphiboles), but small amounts of talc, rutile (titanium oxide) and calcium sulfate fibers were also found. Asbestos fiber concentration ranged from 200 to 300 ff/mg of dry tissue and represented 0.5–1% of total particulate.

Seven groups of silicates were detected: micas, clays, talc, chlorites, serpentine and amphiboles. The majority of particles had a diameter ranging from 1 to 5 μ m. No particles more than 30 μ m in diameter were observed.

Asbestos fibers were represented for more than two thirds by chrysotile and ranged in length from 1 to 8 μ m, with a length/width ratio higher than 10 (Figure 2).

Up to sixteen different metallic elements, in the form of oxides and sulfates, were found (Figure 3). Nearly 80% of particles ranged in size from 0.1 to 1 μ m and no particles larger than 2 μ m were found. Six elements (Al, Ca, Ti, Cr, Fe, Ni) could be identified in more than two thirds of subjects.

Dependence between Mineral Particulate, Age and Life-style of Subjects

The dependence between particle concentrations and the age of subjects is shown in Figure 4. In general, concentration appeared to increase with age. Moreover, observation in light microscopy showed that anthracosis, which was scored from 0 (absent) to 3 (severe) also tended to increase with age (Figure 5). Smoking habit seemed to influence the quantity of mineral particulate deposited in the lungs, since in the same age-groups, a greater amount of particulate was found in the lung parenchyma of smokers than in non-smokers (Figure 6).

CONCLUSIONS

Our results confirm the high degree of dependence between the concentration of mineral particulate in the lung parenchyma and the environmental situation. Particularly, it appears that subjects living in an urban area are exposed to toxic and carcinogenic substances released by motor vehicles (heavy metals, asbestos fibers). Finally, our results confirm the effect of smoking on the quality and quantity of the particulate in the lungs.

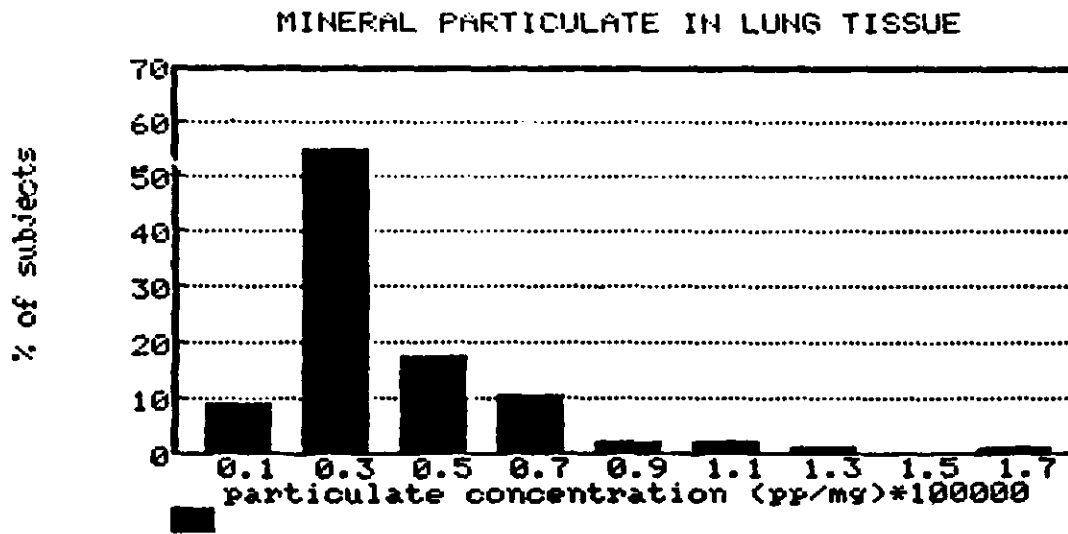

Figure 1. Particulate concentration in the lung parenchyma of sixty subjects.

% OF ASBESTOS QUALITIES
detected in 16% of subjects

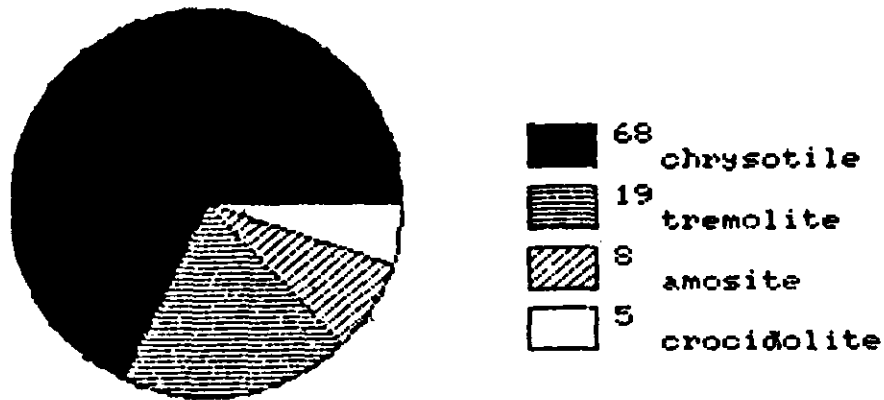

Figure 2. Percentage of asbestos types detected in the lung tissue.

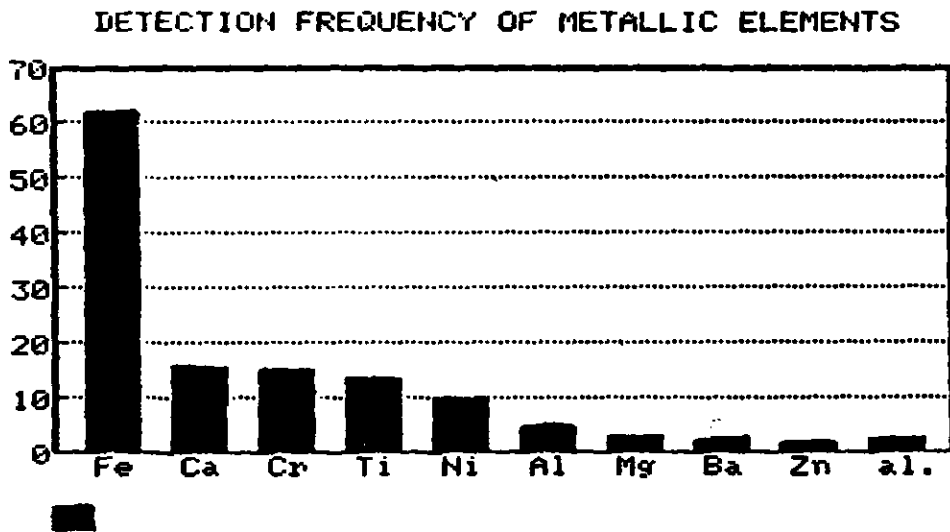

Figure 3. Frequency of the metal elements observed.

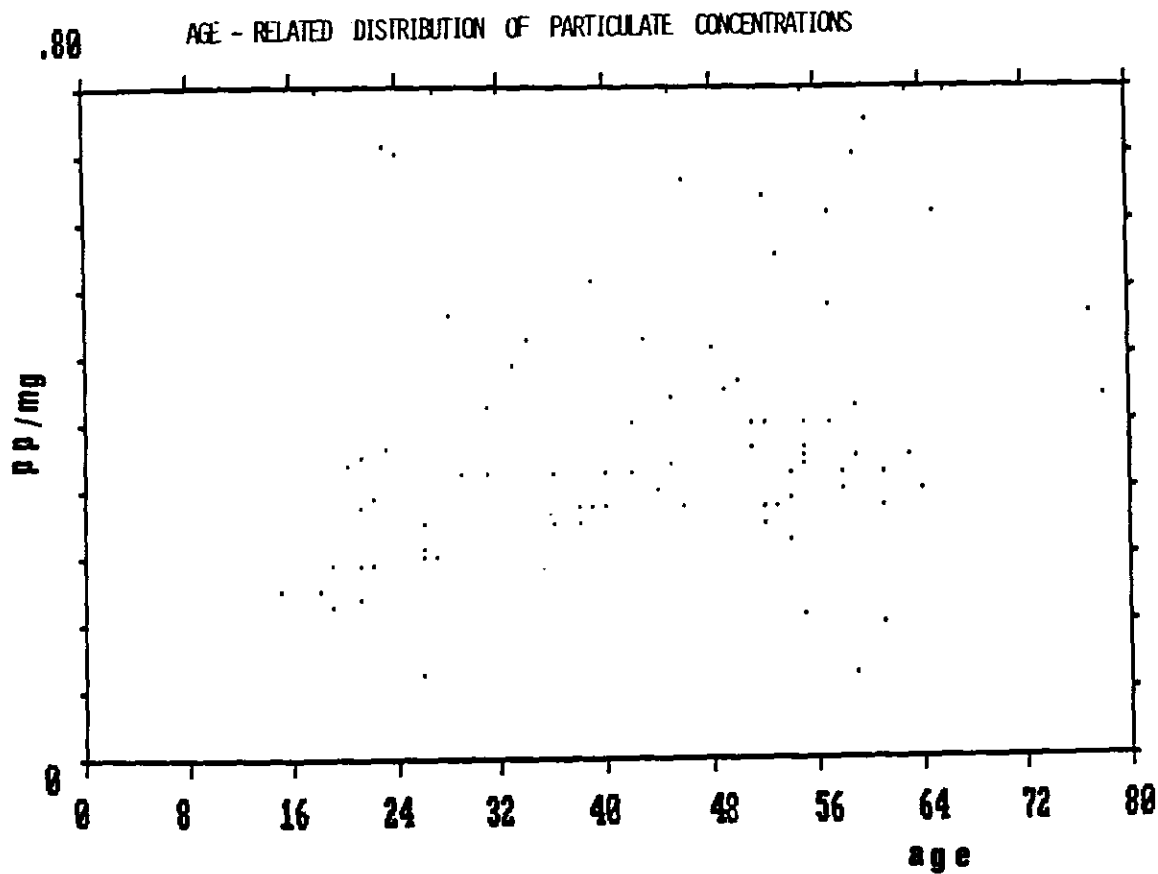

Figure 4. Particulate concentration in relation to the age-groups.

REFERENCES

1. Paoletti, L.: Electron microscopy techniques in the control of mineral dust environmental pollution. *Ultramicroscopy* 12:166 (1983).
2. Paoletti, L., Batisti, D., Caiazza, S., Petrelli, M.G., Taggi, F., De Zorzi, L., Dina, M.A. and Donelli, G.: Mineral particles in the lungs of subjects resident in the Rome area and not occupationally exposed to mineral dust. *Environ. Res.* 4:18-28 (1987).
3. Vena, J.I.: Air pollution as a risk factor in lung cancer. *Am. J. Epidem.* 116:42-56 (1982).
4. Saracci, R.: The interactions of tobacco smoking and other agents in cancer etiology. *Epidem. Rev.* 9:175-193 (1987).

		SUBJECTS FREQUENCY			
AGE CLASSES					
	0	1	2	3	
65			5	5	
55			6	7	
45		1	6	2	
35	1	3	5		
25	1	5	3	1	
	ANTHRACOSIS DEGREE				

Figure 5. Distribution of anthracosis (scored from 0-absent to 3-severe) in relation to age-groups in sixty subjects.

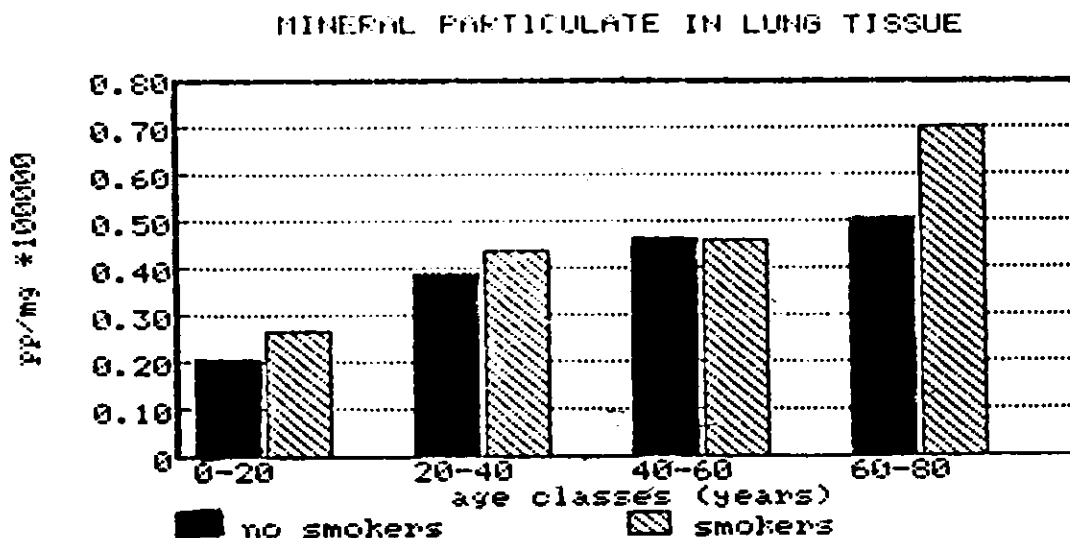

Figure 6. Influence of smoking in particulate concentration in the lung tissue.

PREVALENCE OF PNEUMOCONIOSES AMONG PHOSPHATE ROCK WORKERS IN BRAZIL

EDUARDO MELLO DE CAPITANI

Department of Preventive and Social Medicine
UNICAMP, Campinas, Sao Paulo, Brazil

INTRODUCTION

The phosphate rock as a pure chemical compound is defined as a calcium phosphate, $Ca_5(F, Cl)(PO_4)_3$. Its use in the fertilizer industry is well known all over the world and has increased since the 2nd world war end period. The industrial manipulation of that compound has brought concern about fluorose hazard by the treatment of the phosphate rock by H_2SO_4 or other strong acids to liberate phosphate rich compounds. Some respiratory illnesses mainly of upper airways were described related to this manipulation.^{3,4,6,7,8,9,10} A very poor literature is available concerning pneumoconioses hazard linked with inhalation of the powdered rock.^{1,2,6,6,16} In the same way, good reviews about pneumoconioses don't quote any information on phosphate rock pathogenicity.¹⁶

CRETEANU et al.,² in 1969 and PISLARU et al.,¹⁵ in 1969 described 7 (seven) and 6 (six) cases of pneumoconioses in phosphate rock mill and transportation workers. Both of the papers did not tell us anything about the level of free silica in the samples of the inhaled rock. On the other hand, EL GAWABI & IBRAHIM⁵ in 1975 described some cases of pneumoconioses in phosphate rock workers, but the analysis of the inhaled dust showed a high percentage of free silica and the lung disease was characterized as silicosis.

MATERIAL AND METHODS

The workers studied in this investigation were exposed to phosphate rock extracted in the states of Goiás and Minas Gerais, Brazil, where the material is crushed and then transported by train reaching Paulinia, state of São Paulo where the compound is stored in underground mills. The underground work and a twelve hours work shift every day, with only one day of rest each fortnight created a condition of very high risk to lung diseases.

Eighty one workers that had some kind of exposition to the rock dust were asked to participate of the study. During the investigation, eight (8) of them were put out of the study because they did not conclude all the proposed examinations. All the remanent 73 were submitted to a) occupational anamnesis; b) detailed respiratory questionnaire; c) physical examination emphasizing respiratory apparatus; d) pulmonary function tests using Collins Maxi Survey Computer Systems analyzing. The parameters analyzed were the CVF%; VEF_1/CVF and $MMEF FEF_{25/75}$;^{12,13,14,17} e) thorax X-ray which were read by three readers in a blind

schedule using the ILO Classification of Radiographs of pneumoconiosis 1980;¹¹ f) two workers were submitted to lung biopsies through thoracotomy. Tissue samples were stained by H.E., van Giemsa, Masson and argentic dye to found out fibrosis or even reticulin fibres; g) the quantity of free silica in the airborne samples was measured by colorimetric methods using Physical and Chemical Analysis Branch; h) a semiquantitative analysis was done with the airborne sample using an X-ray spectrometry EG 86 ORTEC.

RESULTS AND DISCUSSION

From the 73 examined workers we found 20^{24,7} with pneumoconioses by X-rays characterization.

Trying to determine an average time of exposition for these 20 cases it was found a mean time of 46 months with a range from 12 to 73 months. CRETEANU et al.,² and PISLARU et al.,¹⁵ found a mean time for their workers of 24 and 36 months respectively. The differences between ill and not ill workers concerning the smoke habit were not found significant. Relating to past inhalatory risk conditions, only one worker had previously worked in a fertilizer plant for a short period of time. The majority of the 20 cases didn't suffer from any respiratory symptoms (85%). Fourteen cases (70%) showed $MEFF FEF_{25/75}$ alterations; two cases (10%) mild restrictive patterns; three cases (15%) a pure obstructive pattern and five cases (25%) with normal patterns. Data from the study of CRETEANU et al. obstructive pattern in six of the seven cases. No correlation between time of exposition and lung function alterations was found.

Opacities in thorax X-rays were classified as small and round in 17 cases (85%) and small and irregular in 3 cases (15%). No pleura disease or mediastinum alterations were found (see Table I and Figure 1).

Lung biopsies were examined through optical microscopy. What appeared was a very extense deposit of brownish crystal material with focal refringence to polarized light in the perivascular, peribronquic and septa tissues, also occupying intra alveolar spaces. A mild histiocytary inflammatory reaction with alveolar collapses were also seen. Despite the use for special dyes to find out fibrosis or increased reticulin fibres, no significant fibrosis was seen (see Figures 2 and 3).

Diffraction analysis by EG 86 ORTEC showed relative amounts of Ca, P, Fe, Mn, Si, Ti, Ba, Nb and S. Small quantities of Fluoride are not detectable by this method but it is

Table I
Thorax X-rays Alterations in the 20 Cases of Pneumoconioses

radiologic alterations		n°	%
	round	p 10	50
small		q 7	35
opacities	irregular	s 1	5
		t 2	10
	total	20	100

clear this element exists in the composition of that rock. Despite the good sensitivity of the method for free silica, not even traces were found. Colorimetric methods showed free silica in less than 1% of the total inhaled dust.

CONCLUSIONS

From the results one can conclude about the non fibrogenicity of this pneumoconioses, at least with the available data. A prospective study must be carried out to assess the former statement. A regular follow-up using lung function tests and thorax X-rays must be included in the routine examinations of the phosphate rock workers. The actual etiology of that pneumoconioses should be studied using electronic microscopy linked with microanalysis by X-rays diffraction.¹⁸ The high prevalence of pneumoconioses found in this study must derive from the specially bad conditions for working people were submitted at this plant.

REFERENCES

- CHAUDERON, J.—Phosphates, superphosphates. In: *Encyclopedia of Occupational Health and Safety*. 3rd. ed. (revised) ILO—GENEVA, 1983, p. 1679-80.
- CRETEANU, G. H. et al.—Consiieratii asupra unor cazuri de pneumoconioze la apatita la muncitorii feroviari. *Rev. Medicochir Iasi*, 73:837-42, 1969.
- DERRYBERRY, O.M. et al.—Fluoride exposure and worker health. *Arch. Envir. Health*, 6:503-11, 1963.
- D'ONOFRIO, V. et al.—Osservazioni sulla patologia professionale di operai addetti alla produzione di superfosfati. *Rass. Med. Industr.* 6:369-78, 1954.
- EL GHAWABI, S. H. & IBRAHIM, S. M.—Pneumoconioses in the superphosphate industry. *Egypt. J. Occ. Med.* 3:55-62, 1976.
- FABBRI, L. et al.—Broncopneumopatia cronica e pneumoconiosi in operai addetti alla produzione di acido fosforico. *Lav. Um.* 28:50-57, 1977.
- FABBRI, L. et al.—Patologia respiratoria del ciclo di produzione de fertilizzanti fosfati: 2. Bronchite cronica ed alterazione funzionale respiratorie. *Med. Lav.* 69:723-27, 1978
- GANDEVIA, B. & RITCHIE, B.—Relevance of respiratory symptoms and signs to ventilatory capacity changes after exposure to grain dust and phosphate rock dust. *Brit. J. Ind. Med.* 23:181-87, 1966.
- HODGE, C. H. & SMITH, F. A.—Occupational fluoride exposure. *J. Occ. Med.* 19:12-39, 1977.
- HUGHES, J. P.—Fluorides, a new critical review. *J. Occ. Med.* 19:11-12, 1977.
- INTERNATIONAL LABOR OFFICE—ILO—*Guidelines for the use of ILO—International Classification of radiographs of pneumoconioses*. Revised edition, ILO—Geneva, 1980.
- KNUDSEN, R. J. et al.—The maximal expiratory flow volume curve: its use in the detection of ventilatory abnormalities in a population study. *Amer. Rev. Resp. Dis.* 114:871-79, 1976.
- KORY, R. C. et al.—The veterans Adm-Army Cooperative study of pulmonary function: I. Clinical spirometry in normal man. *Amer. J. Med.* 30:243-58, 1961.
- MORRIS, J. F. et al.—Spirometric standards for the non-smoking adults. *Am. Rev. Resp. Dis.* 103:57-67, 1971.
- PISLARU, V. et al.—Riscul de imbolnavire la apatita in transportul feroviar. *Rev. Medicochir. Iasi.* 73:961-66, 1969.
- ROM, W. N. et al.—Other occupational lung diseases. In: ROM, W. N. Ed.—*Environmental and occupational medicine*. Boston, Little, Brown and Co. 1983, p. 251-266.
- SOBOL, B. J. et al.—Relative value of various a spirometric tests in the early detection of chronic obstructive disease. *Am. Rev. Resp. Dis.* 107:753-62, 1973.
- VALLYATHAN, F.H. Y. et al.—Recent advances in the study of mineral pneumoconiosis. *Pathol. Ann.* 15:77-104, 1980.

Figures not provided.

SIZE CHARACTERIZATION OF INDUSTRIAL PRODUCTS (MMMF) USED IN BUILDINGS AND STRUCTURES AS SUBSTITUTES OF SPRAYED ASBESTOS-CONTAINING MATERIAL

CORRADO CICCARELLI

Istituto Superiore Prevenzione e Sicurezza Lavoro, Rome, Italy

INTRODUCTION

It is known the fire risk prevention problem has determined a very wide use of insulation materials and mainly of asbestos, as a consequence of its desirable physical and chemical properties. For these purposes it has been used in many different industrial sectors, and particularly in considerable quantity in the building industry. In this last field insulation products are mainly used as surfacing materials and partitions to provide both protection from fire spread and acoustic insulation.

In the past, asbestos was sprayed extensively on structural steel structures and decks as fireproofing to enhance their fire resistance. Such use was required in Italy by national regulations on fire prevention.

The health hazard due to the inhalation of airborne fibres arises from dust release in air caused by an aging process, bad maintenance or vandalism actions. All those facts have induced many governments to regulate the use of asbestos products and to ban asbestos-sprayed techniques.

Like in some other countries the Italian Health Ministry has taken urgent measures for asbestos-control in schools and hospitals (circ.n.45 on 10.7.86). Such measures aim at identifying the presence of asbestos and to check if it is in good condition or if there is a potential release of asbestos dust into the air. In this case there will be a health risk and asbestos should be removed. These measures have determined indirectly a lot of work in order to remove asbestos materials from buildings, even if they were not in bad conditions.

Fibrous alternative materials (with the same heat and fire resistance) are generally used as substitutes for asbestos. At present, alternative products are available on the market with a silicate like chemical composition and various morphologies, either fibrous or not-fibrous. Most of them have amorphous structures. As a rule, fibres of alternative products have a diameter coarser than asbestos-fibres, although some of them have size similar to asbestos. Generally such man-made mineral fibres (MMMF) are manufactured with different diameters relating to the specific use they are destined. The most important MMMF are grouped in: slag wools, rock wools, glass wools and continuous filament with diameters varying from 1 up to 20 μm , averaging about 8 μm for filament glass fibres 1-5 μm for insulation wools.

Often a considerable percentage of these fibres shows diameters in the range from less than 3 μm to 0.2 μm .

In this paper, special attention is given to representative products used in public buildings as banks or offices, as substitutes for asbestos.

These materials have been sent by U.S.L. (Local Sanitary Unit) to our Institute to obtain all information about their chemical composition and size characterization, in order to decide their use as asbestos substitutes.

In a recent summary report of WHO-IARC international symposium,¹ an increased lung cancer risk has been reported among workers exposed to small-diameter fibres since the early days of man-made mineral fibres production. The risk has been greater in the rock or slag wool sector than in the glass wool one. Moreover the IARC has revised of carcinogenicity and it has classified MMMF as possibly carcinogenic to humans (Group 2B).

The cancerogenic activity is generally attributed to the fibre dimensions and to their durability in biological tissues. Today the opinion of the scientific community based on the epidemiological, toxicological and mineralogical studies, indicates that any mineral fibre with specific dimensions and sufficient biological durability must be regarded as possibly cancerogenic.

MATERIALS AND METHODS

All materials studied appear composed of fibrous elements and a low density matrix of rounded aggregates. The color is usually brown to white. Inspection of the bulk materials by a stereomicroscope at about 40 X show a very friable consistency and a largely empty structure. Fibres show a wide range of diameters and often they are in association with unfiberized particles mostly in the form of solidified droplets.

Few milligrams of the bulk materials, taken at random were shaken into a beaker with a "policeman" for a few minutes using H202 in order to help particle disgregation and dispersion.

Because of the mechanical treatment, fibre length distribution was not determined in the subsequent analysis. Material was then dispersed in prefiltered distilled water. Aliquots of the suspension were filtered through a polycarbonate filter (NPF), 25 mm diameter, 0.2 μm , by a small funnel (Nuclepore Corp.).

A quarter of each filter was mounted on a carbon stub, 12 mm diameter and coated by a gold layer of approximately 100 nm of thickness.

The samples were analyzed by scanning electron microscope, Cambridge model 200, at 0° tilt angle, 25 KV accelerating voltage. Fibre size was measured directly on the screen, separately recording diameters of 100 fibres.

The airborne samples were collected on 25 mm 0.8 microns cellulosic filters. Half of the filters were cleared and examined by phase contrast optical microscope (PCOM) method. The remaining portion of the filters were mounted on a carbon stub in the same way, but examined by SEM at 15 KV acceleration voltage in order to prevent local overheat.

RESULTS

Table I shows size distributions from bulk samples of materials used as sprayed insulations in buildings.

From diameters distributions it results that in samples 2 and 5 the respirable fraction (diameters less than 3µm) is about 30%, while in the other samples the same fraction is about 60%.

During the removal operation from building structures coated with the material of sample n.1, personal air samples were collected according to the standard method.²

Table II shows a consistent size distribution by diameter and by length of airborne respirable fibres from 4 different samples.

Table I
Frequency of Diameter in the Bulk Materials

Sample	D = 1	1 D 3	3 D = 5	D 5
1	29	39	22	10
2	6	27	33	34
3	20	41	26	13
4	25	35	25	15
5	10	19	34	47

Table II
Size Distribution of Airborne Respirable Fraction

A) Distribution by diameter

μm	D = 1	1 D 2	2 D 3	D 5
%	39	44	15	2

B) Distribution by length

μm	5 L 10	10 L 15	15 L 20	20 L 30	30 L 100	L 100
%	41	18	13	15	11	5

In this case the respirable fraction is about 98% showing a clear preferential loss of coarser fibres. About 40% of these fibres are between 5 and 10 microns in length, and the rest is equally distributed among the subsequent length classes.

Chemically fibres consist principally of silicon, calcium and aluminium. Other elements such as iron, magnesium, potassium are also present.

CONCLUSIONS

Recently there has been an increasing demand for insulation products and especially of man-made mineral fibrous materials to replace asbestos-products.

Owing to the possible fibre release from MMMF insulation

materials in bad conditions, sometimes they have been removed from structures.

The results from this study, even if limited, indicate that the physical characteristics of MMM products show 50% diameters less than 3 microns, while during the removal about 98% of airborne fibres have diameters less than 3 microns.

Although, at present, investigation³ carried out in different countries unnecessary exposures to these types of fibres.

Finally, it seems important that clear information be reported on appropriate labels in which should appear not only technical instructions, but also chemical data as well as the diameter range of fibres in order to evaluate the possible risk of people exposed.

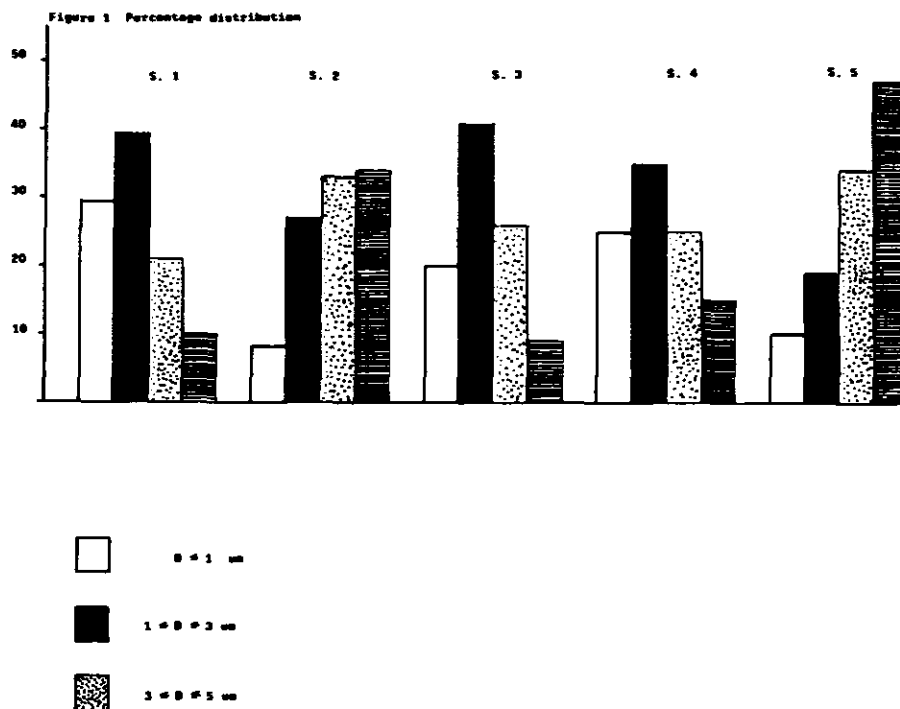

Figure 1. Distribution of fibre diameters of bulk materials.

REFERENCES

1. WORLD HEALTH ORGANIZATION, REGIONAL OFFICE FOR EUROPE: Les fibres minerales artificielles sur les lieux de travail Symposium international, Rapport sommaire, Copenhague (1986).

2. WORLD HEALTH ORGANIZATION, REGIONAL OFFICE FOR EUROPE: Reference Methods for Measuring Airborne Man-Made mineral Fibres, 4, Copenhagen (1985).
 3. Doll, R.: Symposium on MMMF, Copenhagen, October 1986: Overview and Conclusions. *Ann. Occup. Hyg.* 31:805-819(1987).

SILICOSIS IN PIT DIGGERS IN SERRA DA IBIAPABA, CEARÁ, BRAZIL

EDSON JOSÉ DE BARROS HATEM* • Fernando Marcos Torres Bandeira Cavalcanti†

*Occupational Physician

†Occupational Safety Engineer/Fundacentro/Brazil

A survey carried out by technicians from FUNDACENTRO, Pernambuco, showed that out of 134 pit excavators, 38 presented silicosis after clinical and laboratorial examinations. Out of these 38, 5 died during this survey. Environmental evaluations in workplaces were also made through dust measurements inside pits being excavated. A conventional water supply is here considered a definite solution to these problems. Specific measures are also proposed as transient solutions.

We participated in the research on silicosis in Serra da Ibiapaba, approx. 350 km from Fortaleza, because of the professional concern and particularly because of the great social vision of the INAMPS pneumologist, Dr. Márcia Alcântara Holanda, who in her ordinary work as the coordinator of the apprenticeship in pneumology at the INAMPS hospital in Messejana, remembered Ramazzini and asked two patients: "What's your occupation?"

Today, only in Tianguá, a town with 40,355 inh. (IBGE 1980), 138 pit diggers have already been clinically and radiologically examined, and a very large number of workers suffering from the disease was found. FUNDACENTRO participated in this work through its Divisions of Occupational Medicine and Hygiene, its Regional Center in Pernambuco, supported by its National Technical Center, making clinical examinations, radiological comparisons based on OIT standards (International Labor Organization) environmental dust analyses and other risk analyses, general guidance in relation to occupational safety, hygiene and medicine, and chiefly in the proposition of solutions compatible with the serious nature of the situation, in order to solve definitely this crucial problem that affects seven towns in Serra da Ibiapaba, comprising approximately 200,000 people. None of these towns has a conventional water supply, and there is no natural water reservoir in the surroundings. The population has to dig water holes manually, one per family, keeping a large number of workers busy.

HAZARDS OF THE ACTIVITY—BACKGROUND

A pit is generally dug by two persons who substitute each other alternatively. While one worker is inside the pit, the other stays on the surface, helping with whatever is necessary. The pits usually have a diameter of 1,50m and they are around 12m deep. The geologic profile of the soil shows a stratum containing 10m of sandstone, which is easily excavated using tools. There is a hard silicified stratum below it that may only be removed with the use of explosives or

mechanized tools. A sample of this silicified stratum was taken to be analyzed and it was found to contain 97.44% of SiO₂. After this stratum we reach the saturated zone, where the walls of the pit are then covered with premolded concrete rings. A bucket lifted with ropes through a drum fixed to a wooden girder set at the pit entry is used to remove the material. It can also be used by the worker to go up to the surface or down to the bottom. In February 1987, they used to charge the amount of US \$10.00 for each "palm" (approx. 25cm) excavated or US \$385.00 for a whole pit of any size.

Operational Hazards

Due to the poor conditions where the work is performed, it is easy to foresee the numerous hazards involved:

- Falls caused by rope rupture, drum break, rupture of drum fastening, rupture of drum supporting girder, slipping.
- Being buried in the earth by caving in of pit walls.
- Accidents caused by tools in the confined workplace.
- Ergonomic risks due to worker's posture because of confined workplace.
- Misuse of explosives.

Here we wish to focus on a number of irregular proceedings, starting with equipment and material purchase, which is traded freely, with no observance of current laws. The transport, storage and handling are also totally inappropriate. Explosives have been seen in worker's houses in places within children's reach. The preparation of explosives for detonation is done in a very primitive way, even the teeth are employed to fix the detonator to the fuse and it is done in the presence of ordinary people (even children) in residential areas, with no measure taken to isolate the area. Thus, besides the danger of an accidental explosion, there is the danger of stones being thrown at considerable distances, often causing physical and material damage.

Another circumstance which deserves attention is that the worker has only 2 minutes and a half to get out of the pit, after lighting the fuse of the explosive charge at the bottom of the pit. It is easy to imagine what may occur in case he falls because of any reason already mentioned. In the survey we found that at least one fatal accident had been caused by this reason.

Environmental Hazards

Undoubtedly, the biggest hazard of this type of work is the

dust produced by the excavation. In rainy weather, the aerosol is present almost exclusively in the operation of removing the silicified sandstone stratum through mechanical means or explosions (the usual manner). The situation is aggravated in dry weather when the dust is also present in the strata prior to the silicified sandstone. Therefore, the risk generating factors are:

- Low humidity of the soil above the saturated zone.
- Pit depth, making the dust reduction by means of natural ventilation impossible.
- Lack of any exhaustion device.

The concentration of dust is higher just after the silicified sandstone stratum is exploded and it remains like that for hours. The worker generally goes back to the bottom of the pit to remove fragments 3 hours after the detonation which is not enough time for the dust to have dissipated.

MATERIAL AND PROCEDURE

The measurements of these concentrations were carried out since then. The adopted procedures are described on Table I. The threshold limit values represent dust concentrations in workplaces under which it is believed that most of the workers may be repeatedly exposed to during their work-life with no harm to their health.

Procedures for Evaluation and Analysis

The dust sampling was collected by means of 37mm PVC filters, with 5µm porosity, where low flow rate suction pumps were used (pump BENDIX model BDx 44). A one-inch cyclone was used to select respiratory particles. It allows 90% of particles having a diameter smaller than or equal to 2µm to go through and it detains particles with diameters bigger than 10µm. The determination of dust concentration was made by gravimetry and an analytical balance of 0.000010 precision was used. The percentage determination of crystallized free silica in the dust samples was carried out through X-Ray diffractometry.

Note. The BENDIX sampling kit is an equipment for individual use, fitted out in the worker. The samples collected represent the circumstances of exposure to dust when performing any analyzed activity.

The flow rate used in the collection of total dust is 1.5L/min and in the collection of respirable dust it is 1.7L/min. The period for sampling varied according to environmental characteristics.

Procedure for Assistance

The procedure for assisting exposed workers has been the following:

Table I
Threshold Limit for Crystallized Free Silica Dust

THRESHOLD LIMIT	COLLECTED DUST	SAMPLING METHOD	PROCEDURE FOR ANALYSIS
$\frac{8.5}{\%SiO_2+10}$ MPPCD*	Total	Impinger	Field Count
$\frac{8.0}{\%SiO_2+2}$ Mg/m ³ **	Respirable	Gravimetric with Cyclone	Gravimetric (weighing)
$\frac{24}{\%SiO_2+3}$ Mg/m ³ **	Total	Gravimetric	Gravimetric (weighing)

(*) MPPCD = Millions of particles per cubic decimeter

(**) Mg/m³ = Milligrammes per cubic meter

1. Simple spirometry, measuring the forced vital capacity, measuring the forced expiratory volume in the first second of time and forced respiratory flow between 25% and 75% of forced vital capacity.
2. Effort tests (with arterial blood gases, exhausted gas sample and realization of ECG).
3. Fiberoptic bronchopy and collection of bronchiole-alveolar lavage (BAL). Patients with changes in effort tests and normal radiological examinations are subject to a transbronchial biopsy of the pulmonary parenchyma.
4. Determination of the immunological profile of each patient, including: Hemogram, plasmatic protein electrophoresis, serum immunogloblins, cutaneous tests for cellular immunity evaluation, rheumatoid factor.
5. Outdoor pulmonary biopsy, where transbronchial biopsy is not enough for a diagnosis.
6. Diagnosed patients are registered in their hometowns for attendance and especially for treatment of the associated diseases mentioned above.

These stages are carried out in Tianguá, by the team of Dr. Marcia Holanda.

MEASUREMENTS

The evaluations were based on Tianguá. The measurements were done in pits located in 3 different regions of the town. Pit No.1 (urban area), Pit No.2 (suburban area) and Pit No. 3 (rural area). The situation of this hard working population is very serious, as can be seen in Table II, The threshold

Table II
Concentration Measurement of Environmental Dust Inside Pits in the Town of Tianguá, Brazil

PLACE	SAMPLE WEIGHT (Mg)	VOLUME OF AIR SAMPLE (m ³)	%SiO ₂	CONCENTRATION (mg/m ³)	THRESHOLD LIMIT (mg/m ³)	EXCESS*
Pit no.1 Bairro Sto. Antonio	0,33	0,0066	18,2	55,0 TD	1,13	48
Pit no. 1 Bairro Sto. Antonio	0,96	0,0068	18,8	141,2 TD	0,41	344
Pit no. 1 Bairro Sto. Antonio	0.25	0,0034	16,0	73,5 RD	0,44	167
Pit no. 2 Rua das Almas	0,40	0,0045	10,0	88,9 TD	1,85	48
Pit no. 2 Rua das Almas	0,19	0,0075	10,5	25,3 TD	1,78	14
Pit no. 3 Health Center	0,11	0,0051	9,1	21,6 RD	0,72	30
Pit no. 3 Health Center	0,27	0,0085	3,7	31,8 RD	1,40	23

According to NR 15, Governmental Decree 3214/78 of the Ministry of Labor

TD = Total Dust

RD = Respirable Dust

* = Number of times the Threshold limit was exceeded

limit for silica dust occupational exposure was exceeded up to 344 times. The legislation considers these cases as maximum degree insalubrity. Dust concentration at these levels, inevitably causes silicosis. This was confirmed by a number of diagnosed cases in the region.

In Tianguá, out of the 200 pit diggers estimated, 134 were examined. Out of these, silicosis was confirmed in 38 through clinical and laboratorial examinations, and 5 workers, out of these 38, died within 60 days.

CONCLUSIONS AND RECOMMENDATIONS

As far as the workers already affected by the disease are concerned, consequently with no chance of cure, what could be done to help them is give them a monthly life annuity. Therefore, it is necessary that the workers be examined and considered disabled by means of a medical examination. The disease is known to exist and to be extremely serious, however, because it occurs in a deep poverty region, distant from the big cities, prevention is laid aside by the supervising, educational and medical assistance structures in charge of the matter.

It is common knowledge that silicosis prevention in general includes environmental control measures, such as:

- Product substitution
- Process alteration
- Dust suppression in the source by means of moistening
- Process insulation
- Dust removal through a general scattered ventilation, on/site exhausting ventilation or electrostatic precipitation
- Use of personal protective equipment

We consider a conventional water supply system a definite solution to the problem. A dam has already been built 18km from Tianguá, which is just waiting for a governmental decision so that supplementary works can be built and put in operation (water mains, water-treating plant and water supply system). In the rural area the solution would be the machine sinking of wells, with no direct participation of the worker in the process.

In addition to the benefits that these solutions could bring, they would also create jobs for the local population. However, these are not short term measures, thus while water-holes still need to be built as the unique source of potable water for the people, some specific measures could be carried out:

- For the use of explosives—Careful attention to safety instructions about transportation, storage and handling of these materials.
- Provide appropriate safety conditions in order to avoid falls when going down and up the pit. Provide appropriate dimensions for ropes, drums, sheaves and support beam.

- Keep the excavation site moist.
- Wait for at least 24 hrs after the explosion before entering the pit.
- Standardize a diameter for the water-hole of at least 2,50m so that the worker may have better working conditions.
- Limit the use of personal protective equipment, which should only be used as a transient solution for its several deficiencies and above all, its low efficiency and discomfort for the person who uses it.
- Cover the pit walls with pre-molded concrete rings as the excavation gets deeper.
- Make regularly the previously mentioned examinations in accordance with the current labor legislation at the expense of the Ministry of Social Welfare.

However, a question is to be asked: How are these pieces of information to get to the workers, and principally, how to make them understand how relevant they are? Dr. Márcia Alcântara has taken the first steps in relation to this. In Tianguá, on a daily radio program she talks about the general aspects of the problem attacking the pit diggers of the region. The workers themselves, after the first deaths, have mobilized to fight for better working conditions, but due to the fact that most workers are not educated, and need to support themselves and their family, they do not give attention to the matter. While definitive solutions are not adopted, it is necessary to make the transient measures known to mitigate the disease. For this to occur, we suggest the following measures be taken:

1. Campaign about silicosis prevention in the Tianguá daily radio program. Fundacentro may cooperate recording cassette tapes with this information.
2. Fundacentro can prepare posters and booklets to be distributed to health centers, town halls, church communities and labor unions.
3. Educative lectures held at community centers, health centers, schools and churches, given by technicians from the Regional labor office, Welfare and State Health office.
4. Intensification of supervision by the Regional Labor Office of preventive aspects and of the work entailment between employees and employers. Orientation about the use of explosives by the Army.
5. Facilities for purchase of personal respirators or even their distribution free of charge to workers, by the Ministry of Social Welfare together with the State Health office.

Nevertheless, we stand upon the point that the eradication of the problem will only occur completely, when there is the engagement of the federal, state and municipal governments in order to provide these populations with what they do not have so far: a potable water supply system.

DNA FLOW CYTOMETRIC ANALYSIS OF MESOTHELIAL CELLS EXPOSED *IN VIVO* TO ASBESTOS

FRANCIS H.Y. GREEN • Amba Balu

University of Calgary, Calgary, Alberta T2N 4N1, Canada

ABSTRACT

Epidemiologic and experimental studies have established a causal relationship between malignant mesothelioma and exposure to asbestos and other fibrous minerals (e.g., erionite) which have similar structural but not chemical characteristics. Predicting whether a given fibrous mineral will be a human carcinogen is very difficult in view of the long latency interval (usually in excess of 30 years) seen in human cases of mesothelioma. It has been shown by others that mesothelial cells exposed to fine chrysotile fibres *in vitro* exhibit chromosomal damage associated with fibre penetration of the nucleus. In view of the likelihood of DNA damage induced by asbestos, we studied DNA profiles in mesothelial cells exposed to asbestos *in vivo*. Fischer 344 rats given a single intraperitoneal injection of 50 mg crocidolite are being followed for periods up to 18 months. Cell cycle analysis using DNA flow cytometry showed a rapid increase in DNA synthesis (S-Phase) by mesothelial cells, which peaked at 3 days and remained relatively stable until 28 days. Observations at later times have not yet been completed. The proportion of mesothelial cells in S-phase following asbestos stimulation was approximately 3 times greater than that seen in normal mesothelium. The mesothelial cell proliferative response was accompanied by an inflammatory reaction which peaked at 2 weeks. Light and electron microscopy showed asbestos fibres within mesothelial cells. The evidence so far indicates that asbestos stimulates an early and intense proliferative response in mesothelial cells. Based on DNA flow cytometric analysis of 2 human cases of mesothelioma showing marked aneuploidy, we expect to observe the development of chromosomal abnormalities in our experimental lesion. We consider that quantitation of these changes using different types of fibrous minerals and fibrous minerals of different dimensions, will ultimately lead to a short-term bioassay of high predictive value.

INTRODUCTION

The association between asbestos exposure and diffuse malignant mesothelioma (DMM) has now been well established by experimental and epidemiological methods.^{2,9,13,14} Moreover, other fibrous minerals (e.g., erionite) have also been causally implicated.¹⁵

The latency interval of this disease is long (usually 15–40 years from initial exposure) and death generally occurs within 12–14 months of diagnosis. DMM is exceedingly difficult to diagnose, no effective treatment exists, and currently there are no screening techniques for high-risk individuals such as asbestos workers.

In recent years, cell proliferation characteristics of normal and malignant cells have gained increasing attention and have been the focus of studies of various human and animal tumors.^{6,7,10,11} Cytokineticists have relied heavily on the frequency of DNA synthesizing cells to determine the cell cycle traverse characteristics of normal and malignant cells. Structural chromosomal damage and changes in cellular DNA content have been shown in association with several tumors including mesotheliomas.^{3,6,12} Analysis of two cases of human mesothelioma in our laboratory revealed DNA

ploidy changes. (Figure 1) Although the mechanism(s) of these karyotypic changes are not entirely understood, it may involve a direct interaction between asbestos fibres and metaphase chromosomes.¹⁶

Flow cytometry is the latest and in many ways the most practical of the current adjunctive techniques for studying the cytokinetic properties of malignant tumours. However, the cell dynamics of malignant, or indeed of normal mesothelial cells are virtually unknown. To determine the possible value of DNA quantitation by flow cytometry in the evolution of DMM, we studied the cytokinetic properties, specifically the DNA synthesizing phase (S-phase) changes of mesothelial cells exposed to asbestos *in vivo*. Our main purpose was to correlate phase distribution changes of cycling cells with the early histological and cytological alterations induced by asbestos.

MATERIALS AND METHODS

Dust Suspensions

Crocidolite samples were obtained from NIOSH (courtesy Dr. V. Vallyathan). Details of fibre dimensions are shown in Figure 2.

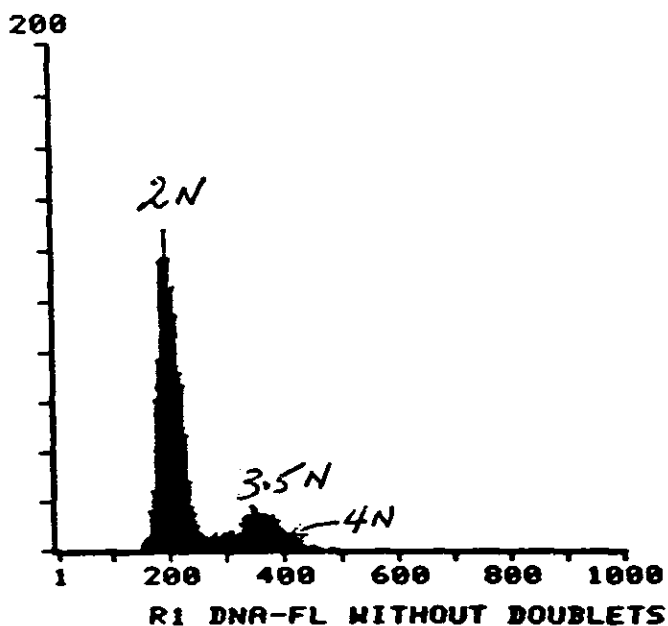

Figure 1. DNA histogram of human mesothelioma showing an aneuploid population at 3.5 N.

Animals

Male Fischer 344 rats were intraperitoneally injected with 50 mg crocidolite asbestos in 10 ml of saline or with 10 ml saline alone. Uninoculated animals served as additional baseline controls. Four animals from each treatment group were sacrificed, under halothane anesthetic, at 1, 3, 7, 14 and 28 days post-inoculation.

Cell Isolation and Separation

The peritoneal cavity was lavaged thrice with normal saline to remove the majority of free-floating cells, mostly macrophages. EDTA (20 ml) was then instilled in the peritoneal cavity, which was lavaged 30 minutes later to extract mesothelial cells from the parietal peritoneum and serosal surfaces (Figure 3). The cell sheets were separated by gentle mechanical agitation. In crocidolite treated animals, firm nodules surrounding asbestos fibres were present throughout the omental and serosal surfaces. These were surgically excised. Cells were extracted by mechanical dissociation, and suspended in RPMI 1640 media.

Cytology

Cytological smears from the peritoneal lavage fluids and from single cell suspensions of the reactive nodules, were spray-fixed with Cytospray, an alcohol-based fixative, and stained with Papanicolaou. Differential cell counts were performed on 100 cells for each specimen. A hemocytometer was used to obtain total cell counts.

Histology

Tissue blocks obtained from the reactive peritoneal nodules and the parietal and visceral peritoneal surfaces, were fixed in Carnoy's solution (60% ethanol, 30% acetic acid and 10% chloroform), and processed in paraffin. 5 μ m tissue sections were stained with hematoxylin and eosin and examined by light microscopy.

Scanning Electron Microscopy

Samples of parietal and visceral peritoneum were immediately excised from animals at termination and immersed in Karnovsky's fixative. Following complete fixation, samples were dehydrated in graded concentrations of ethyl alcohol, critical point dried and coated with gold/palladium. Specimens were examined in a Hitachi S-450 scanning electron microscope.

Flow Cytometry

Single cell suspensions from the above tissues were prepared in RPMI media and fixed in 50% ethanol. The cells were washed twice in PBS and resuspended in 1 ml of PBS, containing 5 μ g of Propidium iodide (Sigma #P-4170, Lot 107F-08201). (Figure 4) This suspension was then filtered through a 44 μ nylon mesh to exclude cell clumps. Cell cycle analysis was performed with a FACS Ortho® flow cytometer. During flow cytometry, cells were excited at 488 nm. Red fluorescence from Propidium iodide (PI) was collected through a 600 nm wavelength long pass filter and recorded as a measure of total DNA.

The resulting electrical pulses were stored in the memory unit of a pulse height analyzer and displayed as a histogram. The phase distribution of each cell population was ascertained from the DNA histogram.⁸

RESULTS

Cytology

Analysis of cells isolated from the abdominal cavity by saline wash (free floating cells) from all groups, showed that more

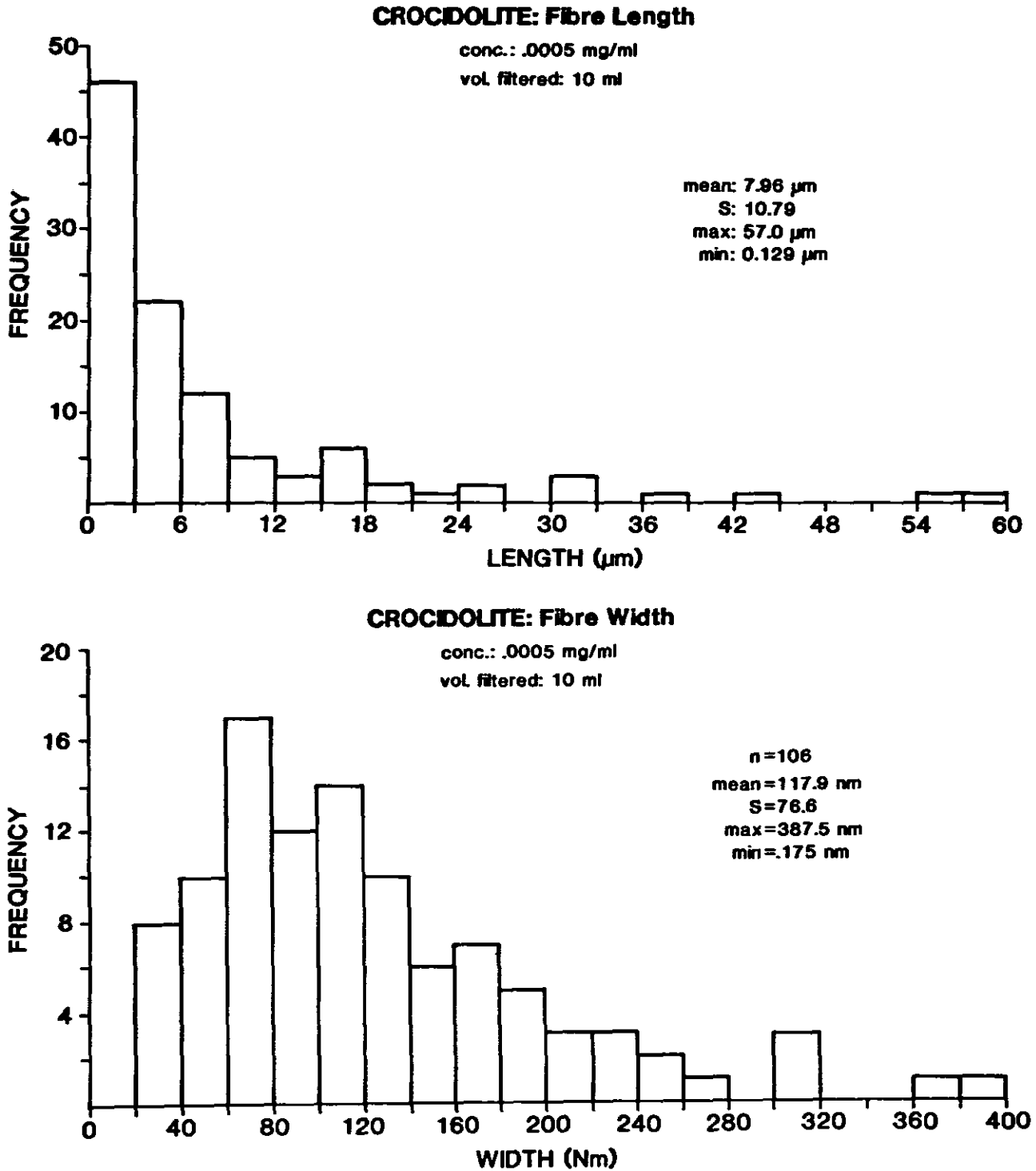

Figure 2. Crocidolite asbestos—fibre dimensions: a) fibre length; b) fibre diameter.



Figure 3. Sheet of normal mesothelial cells obtained by EDTA extraction (Papanicolaou stain X 400).

than 90% were macrophages and polymorphonuclear cells. Rats injected intraperitoneally with saline showed a small increase in inflammatory cells at 24 hrs which returned to normal values by 3 days. (Figure 5) Asbestos injection, on the other hand, produced an intense and sustained inflammatory reaction which peaked at 14 days. Lavageates from asbestos exposed animals also contained large numbers of red blood cells, at 1, 3 and 7 days.

Cytological examination of cells extracted from the mesothelial surfaces of saline injected rats by EDTA, showed that over 90% were of mesothelial type. EDTA extraction of asbestos treated rats produced a more mixed cellular profile, with mesothelial cells constituting 70-90% of the total population. The number of cells retrieved from saline injected rats remained relatively constant at all time periods. (Figure 5) Maximal retrieval of mesothelial cells in the crocidolite treated group occurred at 7 days, reflecting the increased proliferative response (see below).

Histology and Scanning Electron Microscopy

The normal mesothelium consisted of a single layer of flattened mesothelial cells on a basal lamina overlying a thin connective tissue stroma. A distinct submesothelial cell population was not apparent by light microscopy.

Asbestos injection produced an early and intense acute in-

flammatory reaction in the mesothelial and submesothelial tissues, consisting of capillary dilatation, edema and macrophage and polymorphonuclear cell infiltration. The serosal surfaces were covered with a fibrinous exudate. (Figure 6) This inflammatory response was observed at all time periods, but by 28 days macrophages predominated in the inflammatory infiltrate.

Initially, the asbestos fibres lay on the peritoneal surfaces and were concentrated on the omentum, upper small intestine, and around the liver, spleen and stomach. Fewer fibres were noted on the parietal surfaces of the peritoneal cavity. At subsequent time intervals, the majority of fibres were actively phagocytosed by reactive mesothelial cells and incorporated into the submesothelial tissues. Fibres also became trapped within the tissues through infolding of omental surfaces (Figure 6). Incorporation of fibres into the peritoneum was associated with the proliferation of both surface and submesothelial cells (Figure 7). The former became multilayered and developed hyperchromatic and irregularly shaped nuclei. Many assumed bizarre multinucleate forms (Figure 6). Scanning electron micrographs revealed these cells to be highly abnormal and many had fibres penetrating their cytoplasm. (Figure 8) Submesothelial cell proliferation was associated with diffuse thickening of the peritoneum and nodule formation. (Figures 9, 10) At 28 days post-injection, collagen was also found within the nodules.

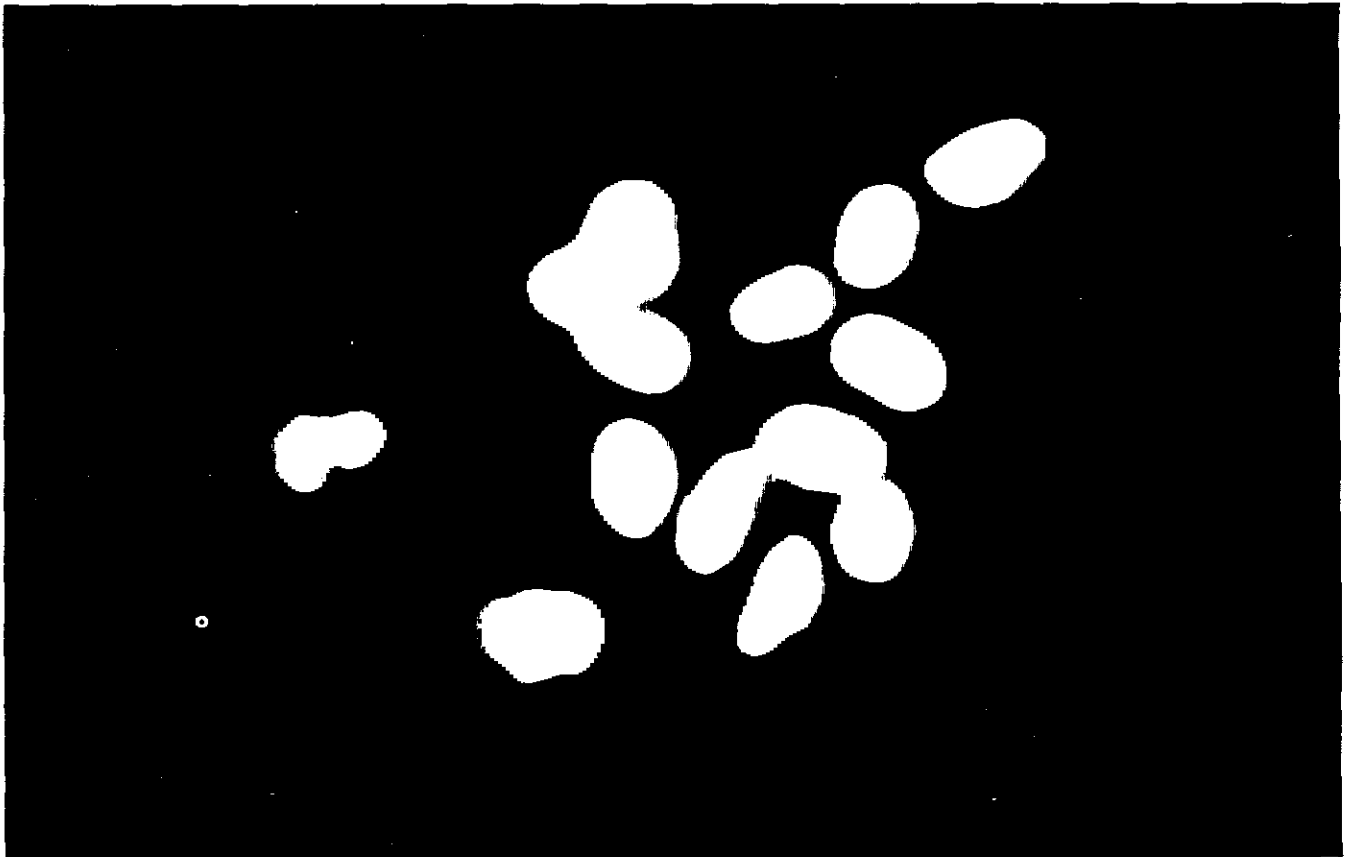

Figure 4. Fluorescent micrograph of normal mesothelial cells stained with Propidium iodide (X 1000).

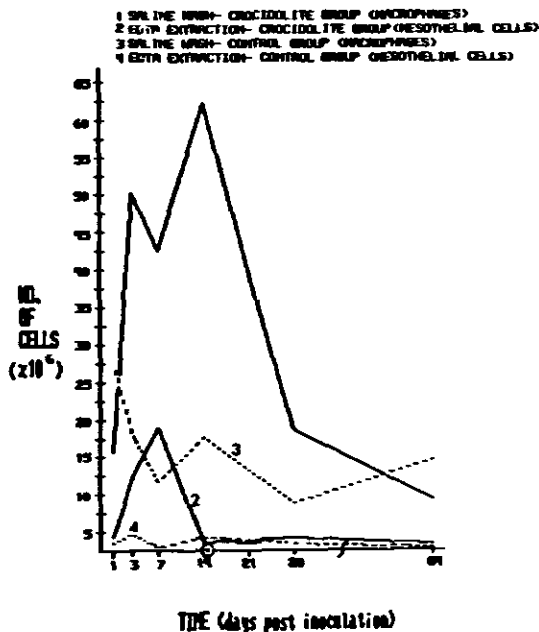

Figure 5. Total and differential cell counts in lavageates from abdominal cavities of rats exposed to crocidolite asbestos.

Flow Cytometry

Cell cycle analysis of inflammatory cells retrieved from the abdominal cavities, showed similar phase distribution for control and asbestos treated rats. The S-phase values were low and ranged from 0.5-3%. Values pertaining to mesothelial cells differed markedly between the two groups (Figure 11). Approximately 7% of normal mesothelial cells were in the S-phase of the cell cycle at any given time. Saline injection produced a small increase in DNA synthesizing cells (S-phase) at 24 hours, which peaked at 3 days and returned to normal values at 7 days. Crocidolite asbestos, by contrast, produced a rapid increase in the proportion of DNA synthesizing mesothelial cells which reached maximal values at 3 days and was sustained up to 28 days.

Discussion

The inflammatory and proliferative changes associated with intraperitoneal injection of asbestos, have been well documented by others.^{3,4,14} In this study, saline injection alone produced a mild inflammatory response and increased proliferation of mesothelial cells. This response was short lived and normal values returned by 7 days.

Cell cycle analysis of inflammatory cells retrieved from the abdominal cavities of both saline and asbestos treated animals, showed similar distribution of cells in S-phase. These values were typically low (1-2%) and indicate that



Figure 6. Section of visceral peritoneum (omentum) from rat dosed with 50 mg crocidolite IP 7 days previously. There is an intense proliferation of surface and subepithelial mesothelial cells associated with a fibrinous and inflammatory response. The surface mesothelial cells also show giant cell formation and nuclear atypia (X 100 hematoxylin and eosin).

inflammatory cells migrating into the abdominal cavity, are terminally differentiated and do not proliferate in response to asbestos stimulation.

Mesothelial cells, on the other hand, developed an early and sustained proliferative response to asbestos with S-phase populations constituting 20–30% of the total mesothelial cell population. The relatively high S-phase value (7%) for normal mesothelial cells indicates that these cells have a fairly rapid turnover rate. Unfortunately, there is very little recent information on cell cycle characteristics of normal mesothelial cells. Experiments have been initiated in our laboratory to determine these parameters, using DNA flow cytometry combined with bromodeoxyuridine (BuDr) incorporation.⁵

At this stage, it is not possible to say whether the changes observed in mesothelial cell populations exposed to asbestos, are specific for this mineral type or whether they progress to neoplasia. Preliminary experimental studies with Fischer rats suggest that intraperitoneal injection of other dusts (silica, iron oxide and wollastonite) induce less proliferative activity of mesothelial cells than crocidolite asbestos. It should be noted that wollastonite is a fibrous silicate mineral that has potential for substitution in asbestos products. If these preliminary experiments are confirmed, they would indicate the potential utility for this approach as a short term bioassay for assessing the carcinogenic potential of fibrous minerals.

Analysis of two human mesothelioma cases showed a definite second population of cells in both instances with DNA con-

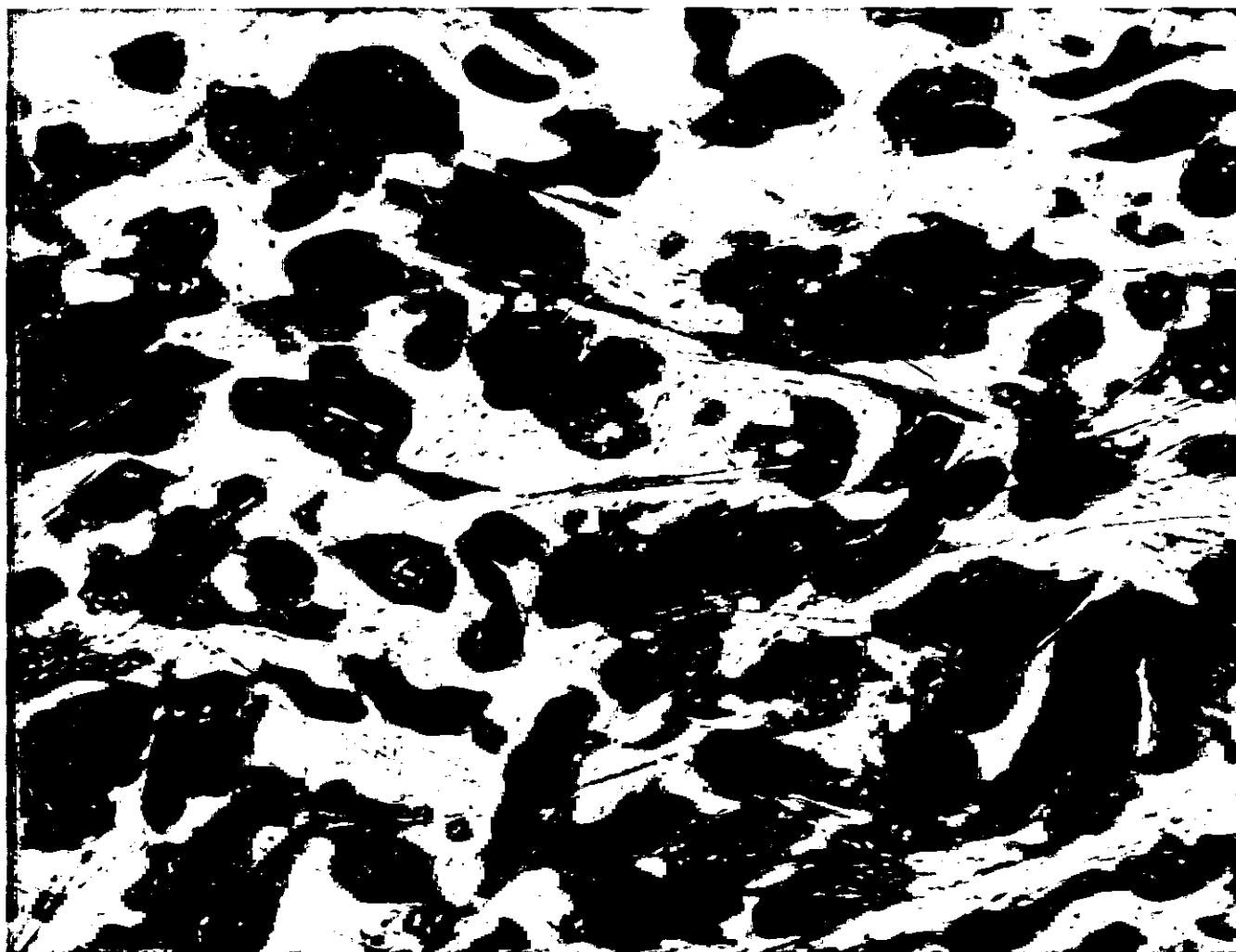

Figure 7. Proliferating mesothelial cells in juxtaposition to asbestos fibres (X 400 hematoxylin and eosin).

tents of approximately 3.5 N (Figure 1). Craighead et al., have reported similar ploidy changes in experimentally induced malignant mesotheliomas in rats.³ We therefore expect to see the development of malignant change and changes in DNA ploidy in our experimental animals. We are par-

ticularly concerned to determine the time of onset of these changes, the clonality of the resulting tumors and the presence or absence of specific cytogenetic abnormalities which might serve as markers of exposure to asbestos or other carcinogenic fibrous minerals.

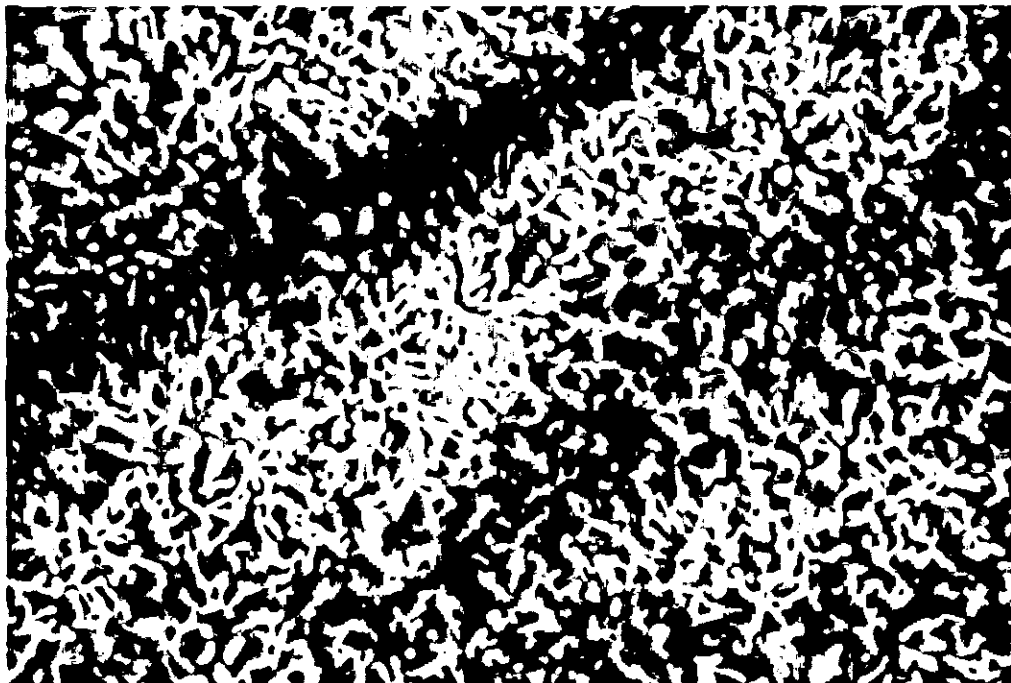
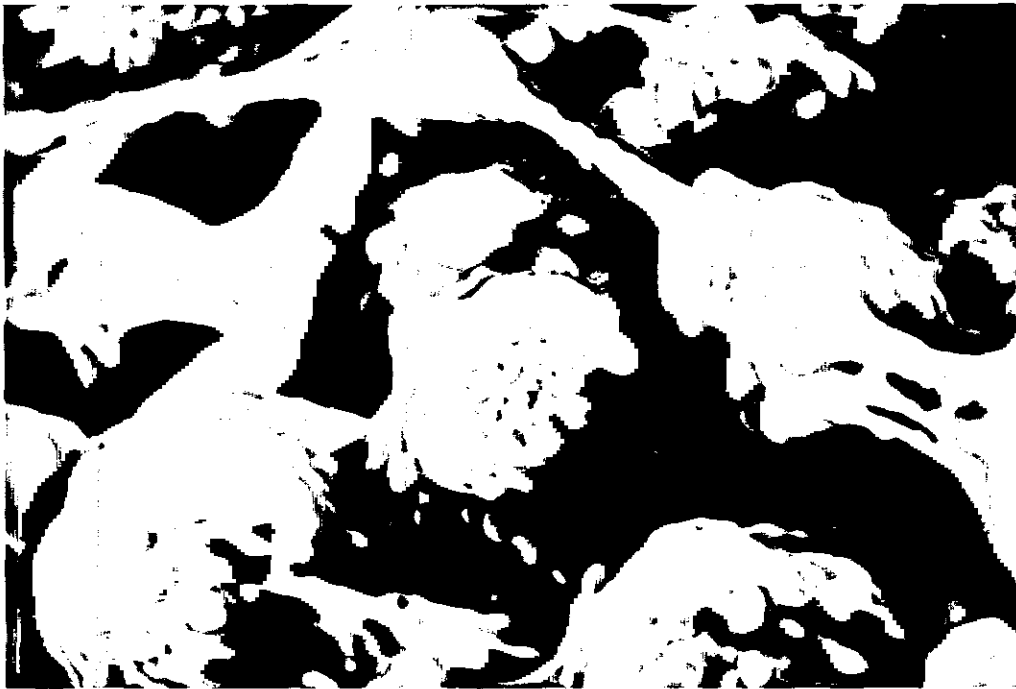

Figure 8. A. Scanning electron micrograph of peritoneal surface of rat two weeks after receiving 50 mg crocidolite asbestos I.P. The mesothelium is hyperplastic and shows incorporation of asbestos fibres into the mesothelial cells. **B.** Normal mesothelium (X 2000).

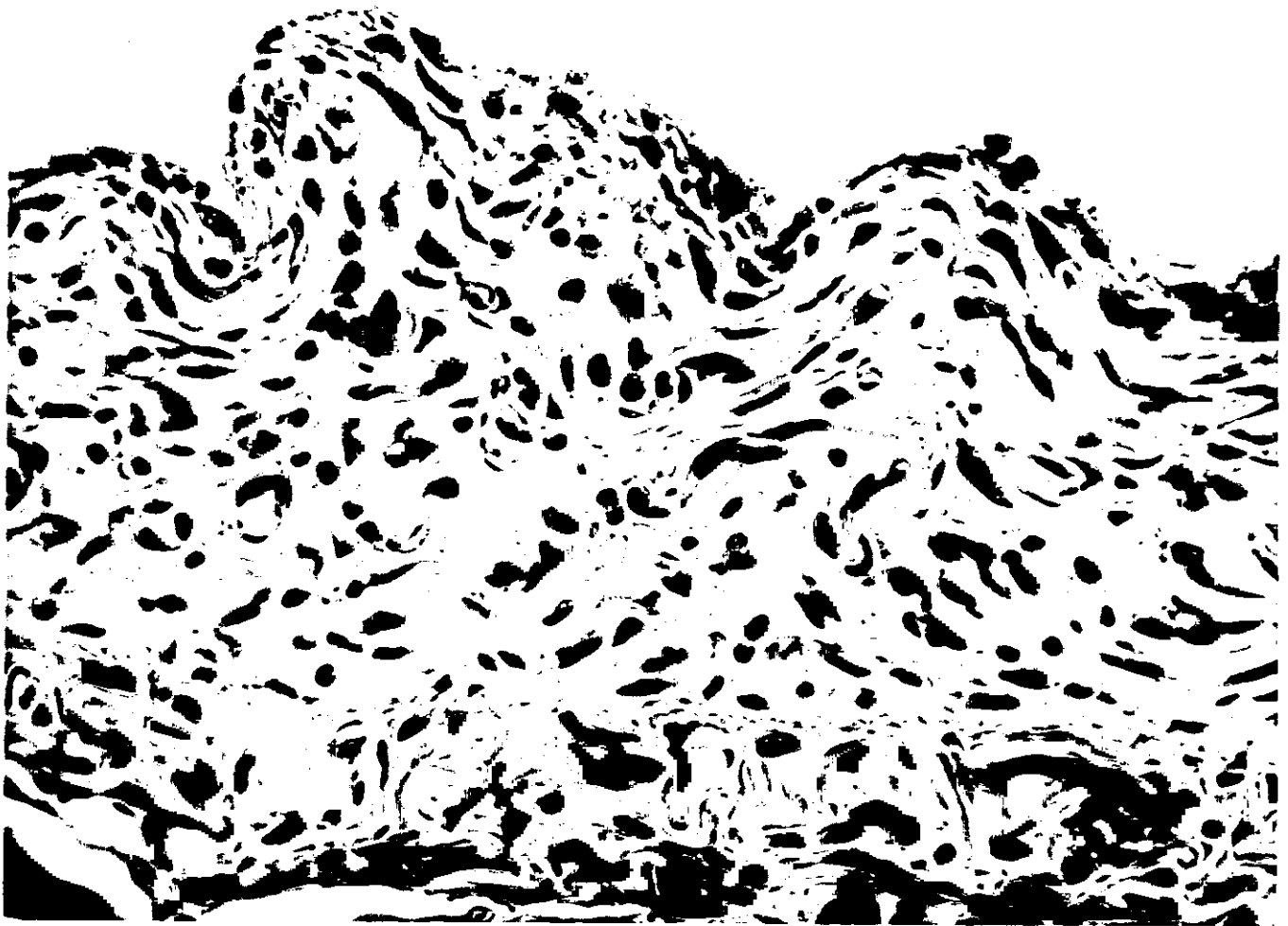

Figure 9. Serosal aspect of abdominal cavity from rat exposed to crocidolite asbestos two weeks previously. There is a marked proliferation of spindle-shaped submesothelial cells (X 250 hematoxylin and eosin).

REFERENCES

1. Ballantyne, K.C. et al.: Flow cytometric analysis of the DNA content of gastric cancer. *Br. J. Cancer*. 56:52-54 (1987).
2. Becklake, M.R.: Asbestos related diseases of the lung and other organs: their epidemiology and implications for clinical practice. *Am. Rev. Resp. Dis.* 114:187-237 (1976).
3. Craighead, J.E., Akley, N.J., Gould, L.B., Libbus, B.L.: Characteristics of tumors and tumor cells cultured from experimental asbestos-induced mesotheliomas in rats. *Am. J. Path.* 129:448-462 (1987).
4. Davis, J.M.G.: The histopathology and ultrastructure of pleural mesotheliomas produced in the rat by injections of crocidolite asbestos. *Br. J. Pathology*. 60:642-652 (1979).
5. Dolbear, F. et al.: Flow cytometric measurement of total DNA content and incorporated bromodeoxyuridine. *Proceedings of National Academy of Science, U.S.A.* Vol. 80, pp. 5575-5577 (1983).
6. Gibas, Z., Li, F.P., Antman, K.H., Bernal, S., Stahel, R., Sandberg, A.A.: Chromosome changes in malignant mesothelioma. *Cancer Genet. Cytogenet.* 20:191-201 (1986).
7. Gray, J.W., Dolbear, F., Pallavicini, M.G., Beisker, W., Waldman, F.: Cell cycle analysis using flow-cytometry. *Int. J. of Radiation Bio.* Vol. 49(2), pp. 237-255 (1986).
8. Krishan, A.: Rapid flow cytofluorometric analysis of mammalian cell cycle by Propidium iodide staining. *J. Cell Biology*. Vol. 66, pp. 188-193 (1975).
9. McDonald, J.C., McDonald A.D.: Epidemiology of mesothelioma from estimated incidence. *Prev. Med.* 6:426-446 (1977).
10. Murphy, W. et al.: Flow cytometry of deparaffinized nuclei compared to histological grading for the pathological evaluation of transitional cell carcinomas. *J. of Urology*. 135:694-697 (1986).
11. Shin, M.C., Firminger, H.: Acute and chronic effects of intraperitoneal injection of two types of asbestos in rats with a study of the histopathogenesis and ultrastructure of resulting mesotheliomas. *Am. J. Pathology*. 70(3):291-306 (1973).
12. Sincock, A., Seabright, N.: Induction of chromosome changes in Chinese hamster cells by exposure to asbestos fibres. *Nature*. Vol. 257, pp. 56-58 (1975).

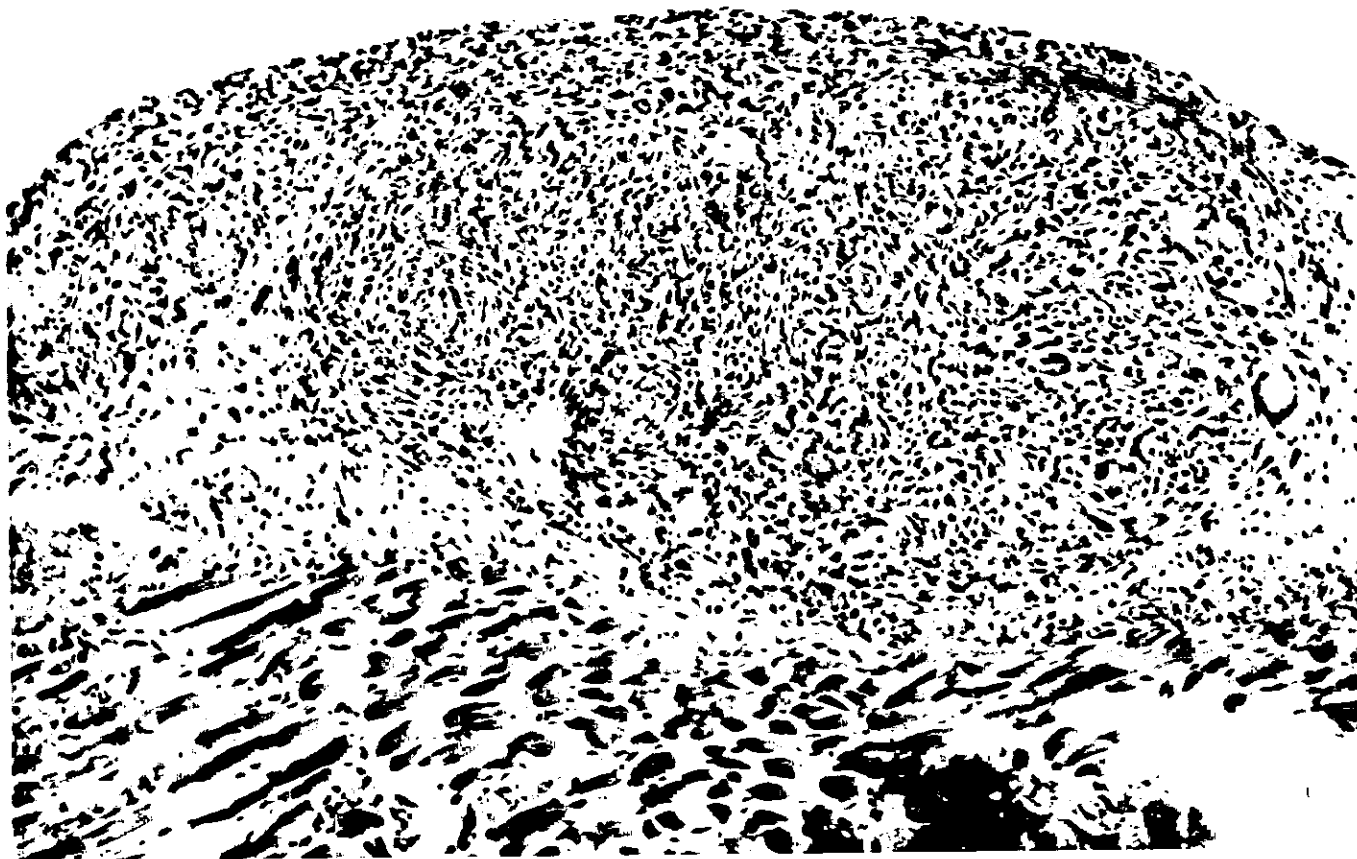

Figure 10. Nodular lesion on parietal aspect of peritoneum of a rat 7 days after receiving 50 mg crocidolite I.P. Giant cells are common in this lesion (X 100 hematoxylin and eosin).

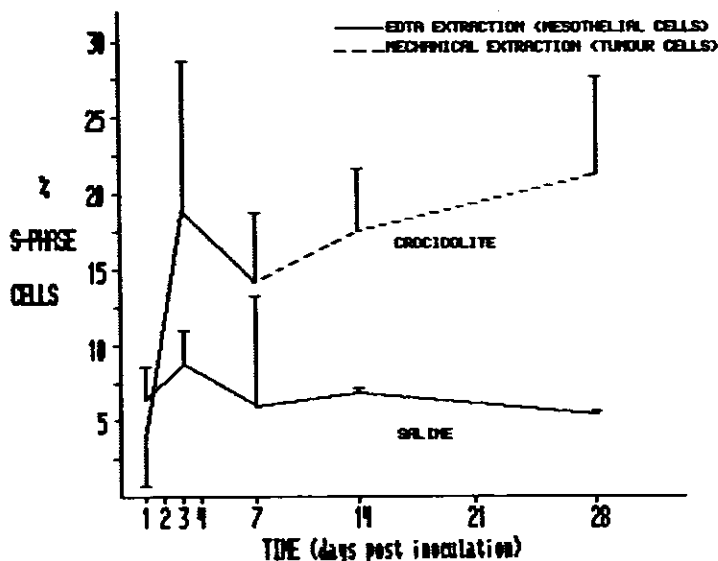

Figure 11. Percentage change in mesothelial cells in S-phase with time in response to intraperitoneal injection of asbestos or normal saline.

13. Solomons K.: Malignant mesothelioma clinical and epidemiological features. *South African Med. J.* 66:407-412 (1984).
14. Wagner, J.C. et al.: Experimental production of mesothelial tumors of the pleura by implantation of dusts in laboratory animals. *Nature*. Vol. 196, pp. 180-181 (1962).
15. Wagner, J.C., Skidmore, J.W., Hill, R.J., Griffiths, D.M.: Eronite exposure and mesotheliomas in rats. *Br. J. Cancer*. 51:727-730 (1985).
16. Wang, M.D. et al.: The interactions between asbestos fibers and metaphase chromosomes of rat pleural mesothelial cells in culture. *Am. J. Path.* pp. 343-349 (February 1987).

ACKNOWLEDGEMENTS: Technical expertise was provided by M. Skromeda. Secretarial assistance was provided by Marguerite J. Schultz. This work was supported by the Alberta Heritage Foundation for Medical Research, Grant #71-8168.

ALTERATIONS IN PULMONARY XENOBIOTIC METABOLIZING ENZYME SYSTEMS IN ASBESTOTIC ANIMALS

QAMAR RAHMAN, Ph.D. • S. G. Khan, M.Phil. • S. Ali, Ph.D

Industrial Toxicology Research Centre, Post Box No. 80, Mahatma Gandhi Marg
Lucknow 226001, India

INTRODUCTION

The synergistic interaction of asbestos and tobacco smoke in the genesis of bronchogenic carcinoma has been reported extensively by both epidemiological and experimental studies.^{1,30,42,18,26,31,49} In spite of several efforts in this direction, the precise biochemical mechanisms involved in the potentiating effects of asbestos in the development of bronchogenic carcinoma remains obscure. It is conceivable that the fibres may adsorb the known carcinogens of cigarette smoke on their surface and thus facilitate their entry and retention in the system.^{27,28} Experimental studies have shown the adsorption of benzo(a)pyrene, a major component of cigarette smoke on the surface of asbestos and their poor excretion from experimental animals.^{41,44} Alternatively, asbestos fibre may directly modify carcinogen metabolizing enzyme system, viz. activation and conjugation reactions. It has been reported that asbestos fibres partially inactivate microsomal mixed function oxidase (MFO) system.^{25,40} The present paper is concerned with the alterations in the xenobiotic metabolizing enzyme system, lipid peroxidation, antioxidant levels in the lung of rats at progressive stages of dust exposure.

MATERIALS AND METHODS

Dust

Chrysotile UICC standard reference sample, particle size < 30 μ , was obtained as a gift from Dr. J.B. Leinweber, John-Manville Mills, U.S.A.

Chemicals

Benzo(a)pyrene, 3-hydroxy benzo(a)pyrene, styrene epoxide and bovine serum albumin were procured from Sigma Chemical Co., U.S.A. All the other chemicals and reagents were either purchased from V.P. Chest Institute, New Delhi or Sisco Research Laboratories (SRL), Bombay, India, and were of analytical grade.

Treatment of Animals

Male albino rats from the ITRC colony, weighing 150–180 gm were used. The dry dust and 0.15 M NaCl were separately autoclaved at 15 lbs pressure for 15 min, suspended and mixed thoroughly just before inoculation. The animals were intratracheally instilled with 5 mg of dust suspended in 0.5 ml of normal saline, according to the procedure, described by Zaidi.⁵⁴ Corresponding controls received 0.5 ml of

normal saline only. The animals were maintained on a commercial pellet diet, supplied by Hindustan Lever Limited, Bombay, India and tap water *ad libitum*. Six animals from each group were sacrificed at 1, 4, 8, 16, 90 and 290 days after inoculation.

Isolation of Microsomes

The rat lung microsomal fraction was isolated by the procedure of Johannesen et al.²²

Enzyme Assays

Benzo(a)pyrene hydroxylase was assayed by the fluorimetric techniques as described by Dehnen et al.⁸ The quantitation of phenolic metabolites was based on comparison of fluorescence to a standard solution of 3-hydroxy benzo(a)pyrene. Epoxide hydratase activity was measured by the fluorimetric technique according to the method of Dansette et al.⁷ by using styrene epoxide as substrate.

Glutathione-S-transferase activity was determined by the procedure described by Habig et al.,¹⁵ using 1-chloro-2, 4-dinitrobenzene (CDNB) as substrate.

Chemical Estimation

Microsomal cytochrome P-450 was quantitated from carbon monoxide plus dithionite-reduced difference spectra as described by Omura and Sato.³⁸ An extinction coefficient of 91,000 cm^{-1} , M^{-1} was used for absorbance change between 450 and 490 nm. Glutathione content was measured in rat lung cytosolic fraction, according to the method of Ellmann.¹¹

Ascorbic acid content was estimated in lung cytosol according to the procedure of Schaffert and Kingsley.⁴³

Enzymatic and non-enzymatic lipid peroxidation was determined by the procedure of Ottolenghi³⁹ as modified by Hunter et al.¹⁷

Protein was estimated by the method of Lowry et al.,²⁹ with crystalline bovine serum albumin as standard.

Statistics

The values presented mean \pm standard error of six animals, statistical significance was determined by Students' 't' test.

RESULTS

Effect of Chrysotile on Lung Weight

There was significant increase in lung weight of experimental animals at 90 and 290 days after treatment (Figure 1). At 290 days of exposure, the increase was 95% in fresh lung weight over the untreated group.

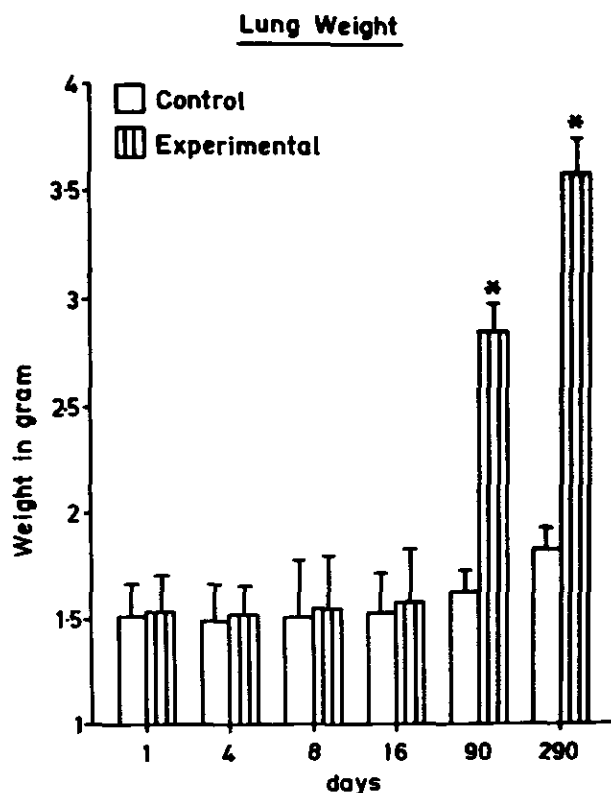

Figure 1. Fresh lung weight of control and chrysotile treated rats. The values are expressed as mean \pm SEM of six animals. * $p > 0.001$.

Effect of Chrysotile on Rat Lung Microsomal and Cytosolic Fractions

The biochemical changes related to drug metabolizing enzyme system induced by chrysotile at different time intervals are given in Figures 2, 3, 4, 5. As Figure 2 shows there was decrease in lung microsomal cytochrome P-450 content from 1 to 16 days but at 90 and 290 days there was significant increase in the content of P-450. At 290 days, the increase was recorded (45%). Same pattern was obtained with the activity of benzo(a)pyrene hydroxylase as shown in Figure 3. At 90 and 290 days, 49% and 48% increase were obtained over their controls, respectively. In case of epoxide hydratase as shown in Figure 4, till 16 days of exposure there was a decrease in the activity but at 90 and 290 days after treatment 90% and 96% increase were recorded respectively, over their controls. However, in cytosolic fraction there was a continuous decrease in the activity of glutathione-S-transferase in experimental animals as shown in Figure 5.

At 90 and 290 days, the decrease in the activity was 21% and 39% which is statistically quite significant.

Effect of Chrysotile on Water Soluble Antioxidants

As recorded in Figure 6, at 90 and 290 days after exposure, a significant decrease in the content of ascorbic acid was

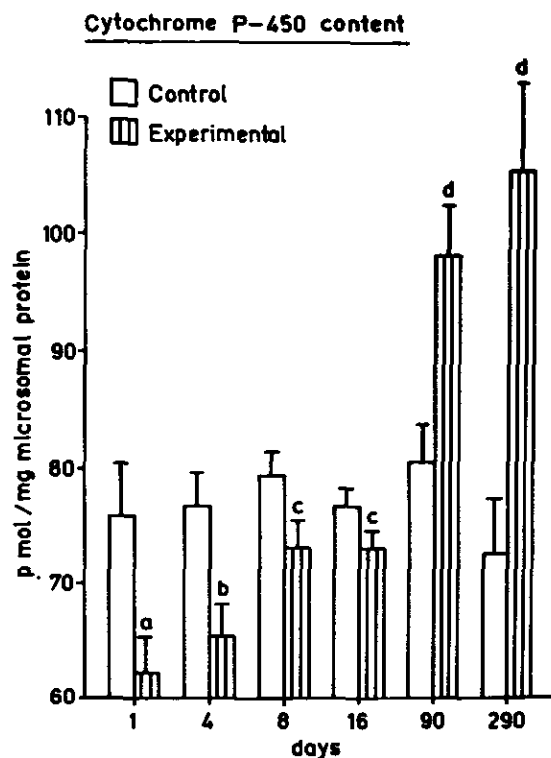

Figure 2. Lung cytochrome P-450 content of control and chrysotile treated rats. The values are expressed as mean \pm SEM of six animals. * $p < 0.02$; ^b $p < 0.01$; ^c $p < 0.05$; ^d $p < 0.001$.

observed in the lung cytosolic fraction of the experimental animals. In case of reduced glutathione content as given in Figure 7, there was continuous decrease in experimental animals at all the stages of exposure but at 90 and 290 days after treatment the decrease is very significant.

Effect of Chrysotile on Lipid Peroxidation

As shown in Figure 8, at all the stages of exposure there was significant induction in microsomal lipid peroxidation in asbestotic animals.

DISCUSSION

It is revealed from the study that asbestos fibre alters mixed function oxidase system of rat lung at all the stages of the exposure. At the initial stages of exposure, the content of cytochrome P-450 and the activity of benzo(a)pyrene hydrox-

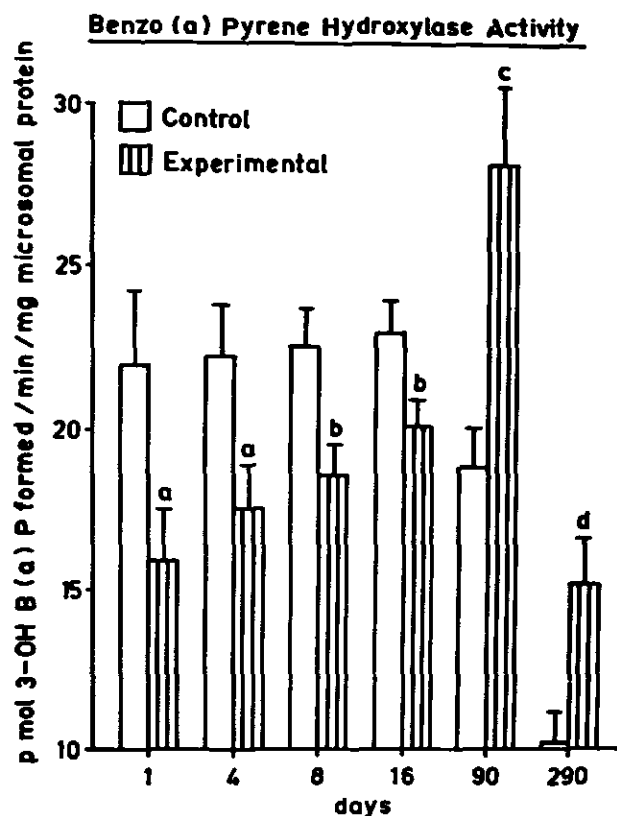

Figure 3. Benzo(a)pyrene hydroxylase activity in lung microsomes isolated from control and chrysotile treated rats. The values are expressed as mean \pm SEM of six animals. ^a $p < 0.05$; ^b $p < 0.02$; ^c $p < 0.001$; ^d $p < 0.01$.

ylase and epoxide hydratase were reduced as compared to their respective controls, but at later stages a reversed pattern with a progressive increase was observed. The decrease in the content of cytochrome P-450 at initial stages of exposure may be due to destabilization of heme proteins.^{10,34,52}

Partial inactivation of microsomal mixed function oxidase system *in vivo* and *in vitro* at the initial stages of the disease have been reported.^{25,40,24,36} The inhibition in the activity of phase I reaction suggests that at the early stages chrysotile prolongs the tissue retention of carcinogens. However, the content of cytochrome P-450 and the activity of benzo(a)pyrene hydroxylase and epoxide hydratase increased at 90 days and thereafter, thus indicating that chrysotile fibre participates actively in the activation of phase I reaction at the advanced stages of the disease when fibrosis developed. At this stage, our results are in agreement with Naseem et al.³⁵ and Dzugaj et al.,¹⁹ who have reported high activity of benzo(a)pyrene hydroxylase in lymphocytes isolated from asbestos workers and liver of asbestos exposed mice. The increase in the activity of aryl hydrocarbon hydroxylase system is very important because they play the major role in the regulation of the microsomal biotransformation of

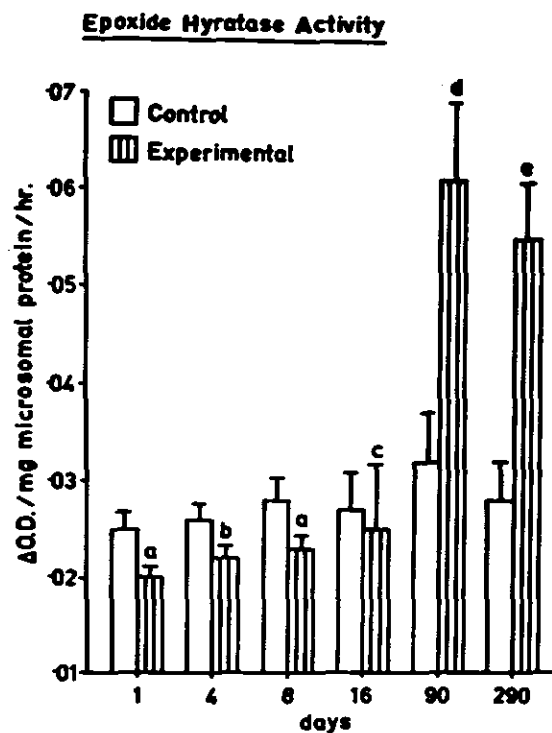

Figure 4. Epoxide hydratase activity in lung microsomes, isolated from control and chrysotile treated rats. The values are expressed as mean \pm SEM of six animals. ^a $p < 0.02$; ^b $p < 0.05$; ^c p -NS; ^d $p < 0.01$; ^e $p < 0.001$.

polycyclic aromatic hydrocarbons (PAHs), the major carcinogen of cigarette smoke.¹³ It is associated with the activation of PAHs in chemical carcinogenesis and also the epoxide hydratase catalyzed formation of dihydrodiols.³⁷ Therefore, the higher activities of microsomal benzo(a)pyrene hydroxylase and epoxide hydratase on prolonged period of asbestos exposure may produce more reactive metabolites from the known carcinogens present in the cigarette smoke in the target tissue thereby increasing the possibility of higher DNA adduct formation.⁴⁰ A linear decrease in the activity of glutathione-S-transferase in the case of chrysotile treated animals was observed. The maximum inhibition for the activity was observed at 290 days of treatment, registering a 39% inhibition. This is in agreement with the findings of Brown et al.³ Glutathione-S-transferase is involved in the detoxification of metabolically modified carcinogens by conjugation with reduced glutathione. The decrease in activity of this enzyme as observed in this study may, in turn, result in the accumulation of unscavenged reactive metabolites which may find access to other sites and exert deleterious effects like the adduct formation with DNA. The hydrolytic enzymes which released from lysosomes have been reported in asbestotic

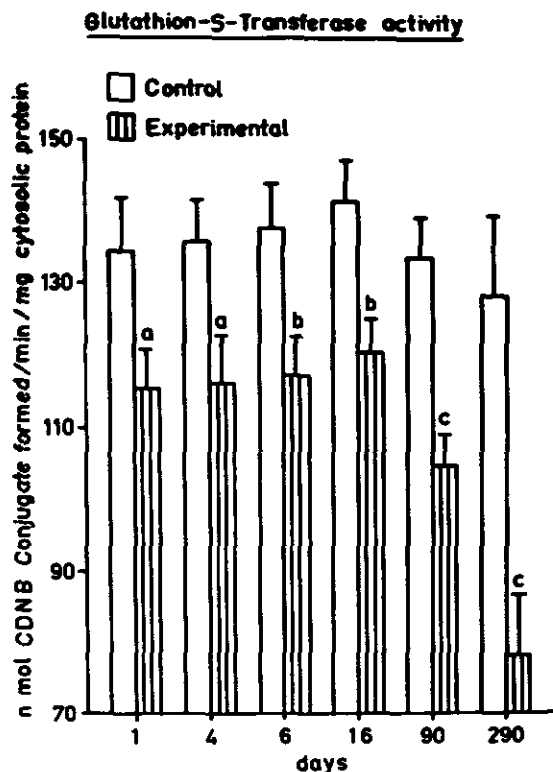

Figure 5. Glutathione-S-transferase activity in lung cytosol, fractionated from control and chrysotile treated rats. The values are expressed as mean \pm SEM of six animals. * $p < 0.05$; $^b p < 0.02$; $^c p < 0.001$.

animals at the advanced stages of the disease⁵⁰ may further negate the clearance by the hydrolysis of preformed conjugates releasing reactive metabolites in the cells.

A higher rate of both enzymatic and non-enzymatic lipid peroxidation have been recorded in pulmonary microsomal fractions isolated from chrysotile treated rats after 1, 4, 8, 16, 90 and 290 days of exposure. Recently, other investigators have also reported similar findings.^{12,21} The lipid peroxides generated due to the peroxidative damage of polyunsaturated fatty acids of the biological membrane have tremendous toxic potential in the biological systems.^{9,14,33,53} These include alterations in membrane fluidity, initiation of free radical chain reactions, and effects on intermediary metabolism. The lipid peroxide also stimulates the metabolism of benzo(a)pyrene.¹⁴ There are several evidences to prove that hydroxyl and superoxide radicals are involved in asbestos induced lipid peroxidation^{5,16,20,32,51} Therefore, the enhanced lipid peroxidation of the lung microsomes in asbestotic rat may contribute to the delayed toxic and carcinogenic effect of these mineral fibres.

A remarkable decrease in the contents of water soluble antioxidants like ascorbic acid and reduced glutathione have been recorded in chrysotile treated rats after 90 and 290 days of exposure. However, insignificant depletion in the levels

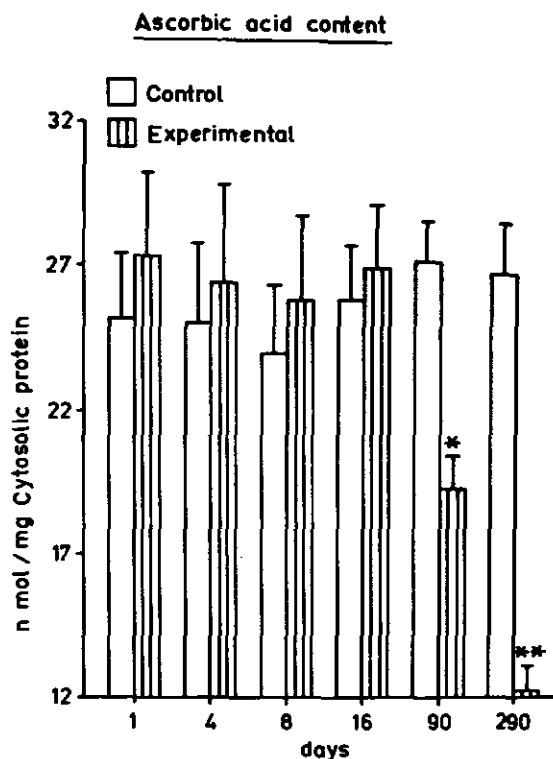

Figure 6. Ascorbic acid content in the lung of control and chrysotile treated rats. The values are expressed as mean \pm SEM of six animals. * $p < 0.001$; ** $p < 0.001$.

of these antioxidants was observed at the initial stages of exposure. Several antioxidants are known to inhibit tumors induced by a variety of carcinogens, including PAHs.^{2,4,6,23,45-48} The low contents of antioxidants in the lung after chrysotile inhalation may hamper the defense of the tissue against other environmental and occupational contaminants. It may be concluded from the above study that the events like quick generation of active carcinogens, their poor elimination from the tissue, hydrolysis of preformed conjugates, generation of free radicals and low antioxidants level in the lung following exposure to asbestos dust may be initiating, favouring and stimulating the process of bronchogenic carcinoma.

REFERENCES

- Berry, G., Newhouse, M.L., Turok, M.: Combined effect of asbestos exposure and smoking on mortality from lung cancer in factory workers. *Lancet*, 2:476-479 (1972).
- Benedict, W.F., Wheatley, W.L., Jones, P.A.: Inhibition of chemically induced morphological transformation and reversion of the transformed phenotype by ascorbic acid in C3H/10T1/2 cells. *Cancer Res.* 40:2796-2802 (1980).
- Brown, R.C., Fleming, G.T.A., Knight, A.J.C.: Asbestos effects on the *in vitro* uptake and detoxification of aromatic compounds. *Environ. Hlth. Perspect.* 51:315-318 (1983).
- Carcinogens: Identification and mechanism of action*, 1st ed., pp. 299-316, A.C. Criffin and C.R. Shane eds. Raven Press, New York (1979).

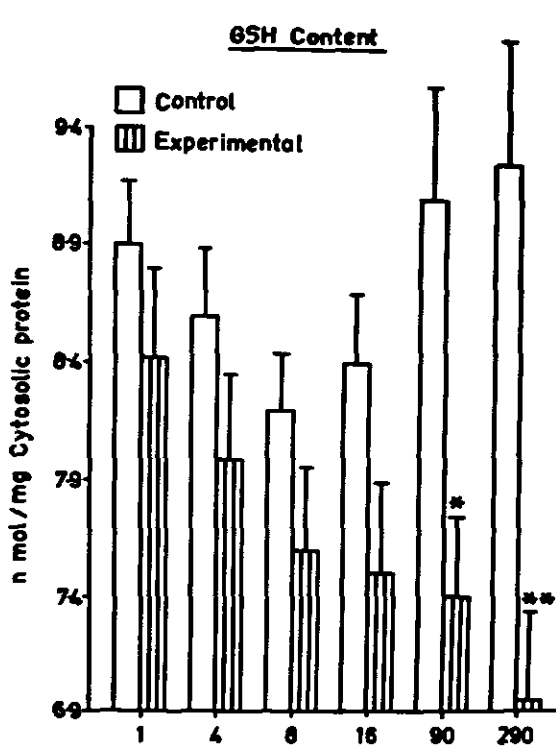

Figure 7. GSH content in the lung of control and chrysotile treated rats. The values are expressed as mean \pm SEM of six animals. * $p < 0.01$; ** $p < 0.001$.

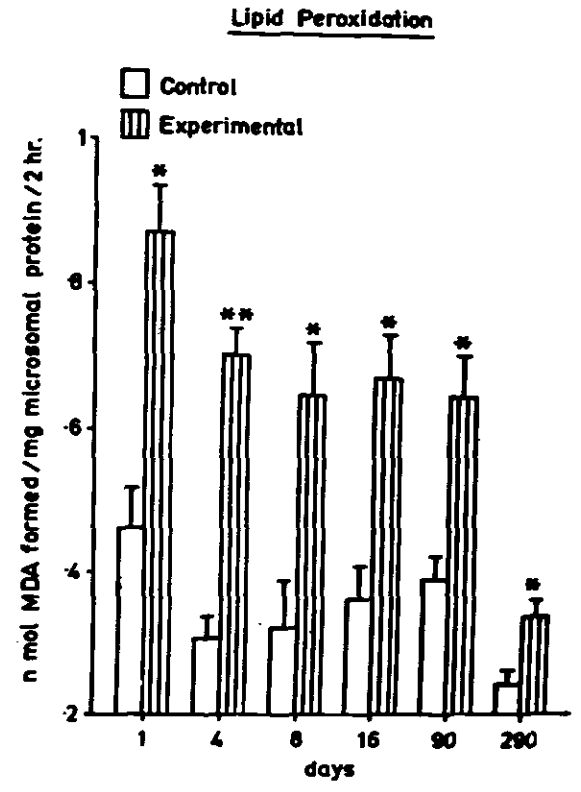

Figure 8. Lipid peroxidation in lung microsomes isolated from control and chrysotile treated rats. The values are expressed as mean \pm SEM of six animals. * $p < 0.001$; ** $p > 0.001$.

- Case, B.W., Clip, M.P., Padilla, M., Kleinerman, J.: Asbestos effects on superoxide production: An *in vitro* study of hamster alveolar macrophages. *Environ. Res.* 39:299-305 (1986).
- Collacchio, T.A., Memoli, V.A., Hanover, N.H.: Chemoprevention of colorectal neoplasm: ascorbic acid and β -carotene. *Arch. Surg.* 121:1421-1427 (1986).
- Dansette, P.M., DuBois, G.C., Jerina, D.M.: Continuous fluorometric assay of epoxide hydratase activity. *Anal. Biochem.* 97:340-345 (1979).
- Dehnen, W., Tomings, R., Roos, J.: A modified method for the assay of benzo(a)pyrene hydroxylase. *Anal. Biochem.* 53:373-380 (1973).
- Dix, T.A., Marnett, J.L.: Metabolism of polynuclear aromatic hydrocarbon derivatives to ultimate carcinogens during lipid peroxidation. *Science*, 221:77-79 (1983).
- Dixit, R., Mukhtar, H., Bickers, D.R.: Destruction of microsomal cytochrome P-450 by reactive oxygen species generated during photosensitization of hemoporphyrin derivative. *Photochem. Photobiol.* 37:173-176 (1983).
- Ellmann, G.L.: Tissue sulfhydryl groups. *Arch. Biochem. Biophys.* 82:70-77 (1959).
- Fonteseaus, M., Mansay, D., Jaquen, M., Pezerat, H.: The stimulatory effects of asbestos on NADPH-dependent lipid peroxidation in rat liver microsomes. *Biochem. J.* 241:561-565 (1987).
- Gelboin, H.V.: Benzo(a)pyrene metabolism, Activation and carcinogenesis: Role and regulation of mixed function oxidases and related enzymes. *Physiol. Rev.* 60:1107-1166 (1980).
- Gower, J.D., Willis, E.D.: The oxidation of benzo(a)pyrene mediated by lipid peroxidation irradiated synthetic dust. *Radiat. Biol.* 49:471-478 (1986).
- Habig, W.H., Pabst, M.J., Jakoby, W.B.: Glutathione-S-transferase: The first enzymatic step in the mercapturic acid formation. *J. Biol. Chem.* 249:7130-7139 (1974).
- Hansen, K., Mossman, B.T.: Generation of superoxide (O_2^-) from alveolar macrophages exposed to asbestiform and nonfibrous particles. *Cancer Res.* 47:1681-1687 (1987).
- Hunter, F.E., Gebicki, J.M., Hoffstein, P.E., Einstein, J., Scott, A.: Swelling and lysis of rat liver mitochondria induced by ferrous ions. *J. Biol. Chem.* 238:828-835 (1963).
- Inhaled Particles*, 1st ed. pp. 553-567. A Critchlow, ed. Pergamon Press, London (1982).
- In vitro Effects of mineral dusts*, 1st ed. pp. 467-474, E.G. Beck and J. Bignon eds. Springer-Verlag, New York, Tokyo (1985).
- In vitro Effects of mineral dust*, 1st ed. pp. 483-488, E.G. Beck & J. Bignon, eds. Springer-Verlag, New York, Tokyo (1985).
- Jazte, J., Leo, I., Wishiewskakrypt, J.M.: Enhanced lipid peroxidation and lysosomal enzyme activity in the lungs of rat with prolonged pulmonary deposition of crocidolite asbestos. *Brit. J. Indust. Med.* 44:180-186 (1987).
- Johannesen, K., Depierre, J.W., Bergstrand, A., Dallner, G., Erester, L.: Preparation and characterization of total rough and smooth microsomes from the lung of control and methylcholanthrene-treated rats. *Biochim. Biophys. Acta* 496:115-135 (1977).
- Kallistratos, G., Fasske, E.: Inhibition of benzo(a)pyrene carcinogenesis in rat with vitamin C. *J. Cancer Res. Clin. Oncol.* 97:91-96 (1980).
- Kandaswami, C., O'Brien, P.J.: The effect of chrysotile asbestos and silica on the microsomal metabolism of benzo(a)pyrene. *Environ. Health Perspect.* 51:311-314 (1983).
- Kandaswami, C., Rahimtula, M. and O'Brien, J.J.: Effects of asbestos fibres on arylhydrocarbon hydroxylase and aminopyrene-N-demethylase activities of rat liver microsomes. *Toxicology* 38:119-132 (1986).
- Kimizuka, G., Ohwada, H., Hayashi, Y.: Co-carcinogenic effect of asbestos and benzo(a)pyrene in the lung of hamster. *Acta Pathol.* 37:465-474 (1987).
- Lakowicz, J.R., England, F., Hidmark, A.: Particle-enhanced membrane uptake of a polynuclear aromatic hydrocarbon: A possible role in co-carcinogenesis. *J. Natl. Cancer Inst.* 61:1155-1159 (1978).

28. Lakowicz, J.R., Bevan, D.R.: Effects of asbestos, iron oxide, silica and carbon black on the microsomal availability of benzo(a)pyrene. *Biochemistry* 18:5170-5176 (1979).
29. Lowry, O.H., Rosebrough, N.J., Farr, A.L., Randall, R.J.: Colorimetric determination of protein with Folin phenol reagent. *J. Biol. Chem.* 198:265-275 (1951).
30. Meurman, L.O., Livilnoto, R., Hakama, M.: Combined effects of asbestos exposure and tobacco smoking on Finnish anthophyllite miners and millers. *Ann. N.Y. Acad. Sci.* 330:419-496 (1979).
31. Mossman, B.T., Light, W., Wei, E.: Asbestos: Mechanism of toxicity and carcinogenicity in the respiratory tract. *Ann. Rev. Pharmacol. Toxicol.* 23:595-615 (1983).
32. Mossman, B.T., Landesman, J.M.: Importance of oxygen free radicals in asbestos induced injury to airway epithelial cells. *Chest*, 835:509-515 (1983).
33. Mukai, F.H., Goldstein, B.: Mutagenicity of malonaldehyde, a decomposition products of peroxidized polyunsaturated fatty acids. *Science* 191:868-869 (1976).
34. Murakami, K., Mason, H.S.: An electron spin resonance study of microsomal Fe x. *J. Biol. Chem.* 242:1102-1110 (1967).
35. Naseem, S.M., Tishler, P.V., Anderson, H.A., Selikoff, I.J.: Arylhydrocarbon hydroxylase in asbestos workers. *Am. Rev. Respir. Dis.* 118:693-700 (1978).
36. O'Brien, P.J., Rahimtula, M., Kandaswami, C.: Asbestos enhanced metabolic activation of carcinogenic polycyclic aromatic hydrocarbons and arylamines. *Proc. Am. Cancer Res.* 25:11-17 (1984).
37. Oesch, F.: Mammalian epoxide hydrolases: Inducible enzymes, catalyzing the inactivation of carcinogenic and cytotoxic metabolites derived from aromatic and olefinic compounds. *Xenobiotica* 3:305-340 (1972).
38. Omura, T., Sato, R.: The carbon-monoxide-binding pigment of liver microsomes. *J. Biol. Chem.* 239:2379-2385 (1964).
39. Ottolenghi, A.: Interaction of ascorbic acid and mitochondrial lipids. *Arch. Biochem. Biophys.* 79:355-360 (1959).
40. Polynuclear Aromatic Hydrocarbons: Physical and Biological Chemistry. 1st ed. pp. 384-403, M. Cooke, A.J. Dennis and G.L. Fisher, eds. Battella Press, Ohio (1982).
41. Pylev, L.N., Roe, F.J.C., Warwick, G.P.: Elimination of radioactivity after intratracheal instillation of tritiated 3,4-benzo(a)pyrene in hamsters. *Brit. J. Cancer* 23:103-115 (1969).
42. Saracchi, R.: Asbestos and lung cancer: An analysis of the epidemiological evidence on the asbestos-smoking interaction. *Int. J. Cancer* 20:323-331 (1977).
43. Schaffert, R.R., Kingsley, G.R.: A rapid, simple method for the determination of reduced, dehydro- and total ascorbic acid in biological material. *J. Biol. Chem.* 212:59-68 (1955).
44. Shabad, L.M., Pylev, L.N., Krivasheeva, L.V., Kulagina, T.F., Nemenki, B.A.: Experimental studies on asbestos carcinogenicity. *J. Natl. Cancer Inst.* 52:1175-1182 (1974).
45. Shah, G.M., Bhattacharya, R.K.: *In vivo* effect of L-ascorbic acid on benzo(a)pyrene metabolite-DNA adduct formation in rat liver. *J. Biosci.* 4:263-270 (1982).
46. Shatos, M.A., Doherty, J.M., Marsh, J.P., Mossman, B.T.: Prevention of asbestos-induced cell death in rat lung fibroblasts and alveolar macrophages by scavengers of active oxygen species. *Environ. Res.* 44:103-116 (1987).
47. Slaga, I.J., Bracken, W.M.: The effects of antioxidants on skin tumor initiation and arylhydrocarbon hydroxylase. *Cancer Res.* 37:1631-1636 (1977).
48. Speirc, J.L., Lam, L.K., Wattenberg, L.W.: Effects of administration to mice of butylated hydroxyanisole by oral intubation on benzo(a)pyrene induced pulmonary adenoma formation and metabolism of benzo(a)pyrene. *J. Natl. Cancer Inst.* 60:605-609 (1978).
49. Topping, D.C., Nettesheim, P., Martini, D.H.: Toxic and tumorigenic effects of asbestos on tracheal mucosa. *J. Environ. Pathol. Toxicol.* 3:261-267 (1980).
50. Viswanathan, P.N., Rahman, Q., Beg, M.U., Zaidi, S.H.: Pulmonary lysosomal enzymes in experimental asbestosis in guinea pigs. *Environ. Physiol. Biochem.* 3:120-126 (1973).
51. Weitzman, S.A., Gracejja, P.: Asbestos catalyzes hydroxyl and superoxide radical generation from hydrogen peroxide. *Arch. Biochem. Biophys.* 228:373-376 (1984).
52. Yamano, J., Ichikawa, Y.: Cytochrome P-450-IV. Stability of cytochrome P-450 and conversion to cytochrome P-420: Isolation and properties of cytochrome P-420. *Pharmacol. Ther.* A2:673-692 (1978).
53. Yonei, S., Furei, H.: Lethal and mutagenic effects of malonaldehyde, a decomposition product of peroxidized lipids on E. coli with different DNA repair capacities. *Mutat. Res.* 88:23-32 (1981).
54. Zaidi, S.H.: *Experimental Pneumoconiosis*, 1st ed., pp. 94-106. Johns Hopkin's Press, Baltimore (1969).

ACKNOWLEDGEMENTS: The authors are thankful to Dr. P.K. Ray, Director, Industrial Toxicology Research Centre, Lucknow, India, for his interest in the work. One of the authors (S.G. Khan) is grateful to State Department of Environment, Lucknow, U.P., for the award of Junior Research Fellowship.

THE ASSOCIATION OF SMALL IRREGULAR OPACITIES ON CHEST RADIOGRAPH WITH AGING IN A NONSMOKING POPULATION WITHOUT OCCUPATIONAL DUST EXPOSURE

ANDREW J. GHIO, M.D. • Attilio D. Renzetti, Jr., M.D. • Robert O. Crapo, M.D.

Pulmonary Division, Department of Internal Medicine, LDS Hospital, and
Division of Respiratory, Critical Care, and Occupational (Pulmonary) Medicine
Department of Internal Medicine, University of Utah, Salt Lake City, UT, USA

ABSTRACT

Small opacities on chest radiograph have been found to increase with age in several studies which have been confounded by dust exposure and/or cigarette smoking. To analyze the association of small opacities with age, we used the ILO 1980 Classification to categorize 159 radiographs of asymptomatic, lifetime nonsmokers without occupational exposure to dusts. The study population included 84 males and 75 females. Age ranged from 15 to 85 years with a mean of 51.2 years and a standard deviation of 19.9 years. Chest radiographs with ages concealed were classified independently by two B readers, Reader 1 found 133 (83.6%) to have profusion category 0/0 and 26 (16.4%) to have category 0/1. Reader 2 found 125 (78.6%) to have category 0/0 and 34 (21.4%) to have category 0/1. No subject had a profusion category greater than 0/1. Significant point biserial correlation coefficients (r_{pb}) were found between profusion category and age ($r_{pb} = .1659$ and $.1611$ for readers 1 and 2 respectively; both $p < .05$). Analysis by gender demonstrated an association of small opacities with age only in females ($r_{pb} = .2761$ and $.3091$ for readers 1 and 2 respectively; both $p \leq .01$). Changes of the breasts which take place with aging may account for this association.

The International Labor Office (ILO) International Classification of Radiographs of Pneumoconioses is used for epidemiologic research and surveillance of workers in dusty occupations.¹ It may also contribute to the evaluation of a worker for compensation. A variety of normal and abnormal structures produce radiographic patterns similar to those of the pneumoconioses complicating interpretation of the ILO 1980 Classification.^{2,3} Studies have described an increase in small opacities on chest radiograph associated with age.⁴⁻⁹ These investigations have been confounded by dust exposure and/or cigarette smoking which also increase small opacities on chest radiographs.¹⁰⁻¹⁵

To test the hypothesis that small opacities increase with age independent of dust exposure and cigarette smoking, we used the ILO 1980 Classification to categorize chest radiographs of asymptomatic, lifetime nonsmokers without occupational exposure to dusts.

METHOD

Subjects were volunteers, predominantly from the Church of Jesus Christ Latter-Day Saints (Mormons). A modified version of the Medical Research Council questionnaire for respiratory symptoms was administered to each individual.¹⁶ A detailed occupational history was also obtained. Height (in meters) and weight (in kilograms) were measured with the subject wearing light outdoor clothing without shoes. A pulmonary physician examined all subjects. A 14" × 17" posteroanterior (PA) chest radiograph was

taken at six feet on full inspiration with the patient in the standing position. PA radiographs with ages concealed were classified independently by the National Institute for Occupational Safety and Health (NIOSH) certified B readers (readers 1 and 2). ILO 1980 Classification standard films were used. Results were reported with OMB Form No. 68-5 1322 provided by NIOSH for the complete classification.

Subjects were included in the study population if they met the following criteria: 1) a lifetime nonsmoker (total smoking of less than 0.5 pack-year and no smoking within six months of the study); 2) no symptoms of chest wall, lung, or heart disease; 3) no history of work in a mine, quarry, foundry, or pottery; 4) no occupational exposure to asbestos, irritating gases, or chemical fumes; 5) a normal physical examination of the chest wall, lungs, and heart; and 6) a PA radiograph of technical quality acceptable to both readers.

The Chi-square goodness of fit test was used to examine the relationship of profusion category with gender.¹⁷ To analyze associations of small opacities with age and an obesity index (weight/height²), the point biserial correlation coefficient (r_{pb}) was applied.¹⁸ The r_{pb} allows correlation of a continuous variable (age and obesity index) with a categorical variable which has two values (all chest radiographs were classified into two profusion categories).

RESULTS

Eight volunteers were excluded from the study as a result

of work in mines or exposure to asbestos. Technical quality prevented classification of six radiographs. The study population included the remaining 159 subjects. There were 84 males and 75 females. Ages of males and females were comparable and were uniformly distributed from 15 to 85 years (Table I). Males were, as expected, taller and heavier.

Table I
Ages and Anthropometric Measures

	<u>Males</u>	<u>Females</u>
n	84	75
Age in years		
Range	15-85	17-84
Mean	52.1	50.2
Stand. Dev.	19.7	20.0
Height in meters		
Range	1.490-1.940	1.460-1.780
Mean	1.733	1.611
Stand. Dev.	0.073	0.068
Weight in kilograms		
Range	59.6-110.9	43.8-104.7
Mean	78.9	67.7
Stand. Dev.	11.4	12.2

Reader 1 categorized 133 (83.6%) radiographs as profusion category 0/0 and 26 (16.4%) as category 0/1. Reader 2 categorized 125 (78.6%) radiographs as category 0/0 and 34 (21.4%) as category 0/1 (Table II). No chest radiograph was found to have a profusion category greater than 0/1. Agreement between the two readers was 80.5%.

In subjects with radiographs categorized 0/1, small opacities were found only in the lower zones. The predominant shapes and sizes were *s* and *t* varieties. There were no large opacities.

Males had a higher prevalence of radiographs categorized as 0/1 but this difference between genders reached statistical significance with reader 2 only (Chi square = 4.08, $p = .04$). Correlation of profusion category with age, with males and females included, provided r_{pb} values of 0.1659 and 0.1611 (readers 1 and 2 respectively). Both were statistically significant (Table III). This association was then analyzed separately for each gender. Males were found to have no statistically significant correlation of profusion category with age while females had significant r_{pb} values of 0.2761 and 0.3091 (Table III). There was an association of profusion category with the obesity index in females with reader 1 only (Table III). However when age and obesity index were simultaneously regressed against profusion category, the association of the obesity index with the profusion category was not found to be significant.

DISCUSSION

No subject in our group of asymptomatic, lifetime nonsmokers without occupational exposure to dusts had a profusion category greater than 0/1 and only 16 to 21 percent were classified as category 0/1. Small opacities were predominantly *s* and *t* in shape and size and were located in the lower zones. Males were found to have category 0/1 radiographs more frequently than females. We found small opacities on chest radiograph to increase with age. However, when analyzed by gender, this association was statistically significant for females only.

A possible explanation of the association of profusion category and age in females is that the small opacities result

Table II
ILO 1980 Classification of Profusion Category

	<u>Reader 1</u>		<u>Reader 2</u>	
	<u>Male</u>	<u>Female</u>	<u>Male</u>	<u>Female</u>
0/0	67	66	59	66
0/1	17	9	25	9

Table III
Correlation of Profusion Category with Age and Obesity Index

	<u>Reader 1</u>		<u>Reader 2</u>	
	r_{pb}^*	<u>P Value</u>	r_{pb}^*	<u>P Value</u>
<u>AGE</u>				
All Subjects	0.1650	.03	0.1611	.04
Males	0.0732	.51	0.0562	.61
Females	0.2761	.01	0.3091	.00
<u>OBESITY INDEX (WEIGHT/HEIGHT²)</u>				
All Subjects	0.0225	.77	0.1478	.06
Males	0.0904	.41	0.0978	.38
Females	0.1334	.24	0.2246	.04

* r_{pb} is the point biserial correlation coefficient between profusion category and either age or obesity index

from changes in breast tissue. The lobules of glandular parenchyma and its stroma are hormonally dependent. With age, involution of these tissues occurs with replacement by adipose tissue.^{19,20} Fat absorbs relatively few X-rays and is therefore less radiopaque than the other tissues of the breast. As a result of this differential absorption, fat would provide sharp contrast on a radiograph to other tissues including persistent strands of fibrous connective tissue, veins, and calcified arteries. These structures may be seen as small opacities in older females and would explain the location of the small opacities and their association with aging in females.

Age in females explained less than 10% (coefficient of determination) of the variance of profusion category in this population without occupational exposure to dusts. Ten percent is an underestimate since the maximal coefficient of determination obtained using the point biserial correlation coefficient is approximately 0.80.¹⁸ In addition, as the proportion of the study population in each of the two categories varies from 0.50, both r_{pb} and the coefficient of determination will be underestimated.¹⁸ In our study, the inequality of subjects in categories 0/0 and 0/1 leads to an error in our determination of the true variance of profusion category explained by age. Although the exact value cannot be determined, it can be concluded that the majority of the variance of profusion category with both genders is unexplained.

Soft tissues overlying the chest wall are thought to account for small opacities⁸ but could not be demonstrated to explain any variance of profusion category in our group. Radiographs of females should be categorized 0/1 more frequently than males as a result of overlying breasts if soft tissues explained a significant portion of the variance of profusion category. There was an effect of gender in our study but both readers categorized more radiographs of males as 0/1. Our study also showed that an obesity index (weight/height²) had no association with small opacities when a multiple regression was done with age as another independent variable. Subject

characteristics not investigated in our study, technical quality of the radiograph, or error in classification may explain the majority of variance of profusion category in nonsmoking, unexposed populations.

Two other investigations have categorized unexposed populations using the ILO Classification. Castellan et al. studied 1422 blue collar workers without exposure to known occupational respiratory hazards.⁸ Only ten workers had profusion category 0/1 and three had categories 1/0 and 1/1. Small opacities were irregular in shape. A statistically significant difference in ages of workers with profusion category $\geq 0/1$ was detected when compared to those with category 0/0. Almost all workers with small opacities were smokers. Epstein et al. found 35 of 200 radiographs of hospitalized patients had a profusion category of 0/1 and 22 had category $\geq 1/0$.²¹ Small opacities were predominantly irregular in shape and located in either the lower zones or all zones of the lungs. The higher prevalence (11%) of radiographs with categories $\geq 0/1$ may have been the result of classifying a hospitalized population. An association of profusion category with age was not described.

Some studies in exposed populations have also shown profusion category to increase with age.^{5-7,9} These findings may have resulted from incomplete accounting for the effect of dust exposure, decreased clearance of the dust by the respiratory tract with aging, confounding factors (e.g., other occupational exposures, environmental exposures, cigarette smoking), or an age associated increase in small opacities independent of dust exposure and confounding factors.

We conclude there is an association of small opacities on chest radiograph with age independent of dust exposure and cigarette smoking in females only. Changes in breast tissue occurring with age may account for this finding.

REFERENCES

1. International Labor Office. Guidelines for the Use of ILO International Classification of Radiographs of Pneumoconioses. Revised edition 1980.

- Geneva, Switzerland: ILO, 1980 (ILO Occupational Safety and Health Series No. 22. Revised 80).
2. Van Ordstand, H.S.: Pneumoconioses and their masqueraders. *J. Occup. Med.* 1977; 19:747-753.
 3. Pendergrass, E.P., Lainhart, W.S., Bristol, L.J., Felson, B., Jacobson, G.: Roentgenological patterns in lung changes that simulate those found in coal workers' pneumoconiosis. *Annals New York Academy Sciences* 1972; 200:494-502.
 4. Amandus, H.E., Lapp, N.L., Jacobson, G., Reger, R.B.: Significance of irregular small opacities in radiographs in coalminers in the USA. *Brit. J. Indus. Med.* 1976; 33:13-17.
 5. Cockcroft, A., Lyons, J.P., Andersson, N., Saunders, M.J.: Prevalence and relation to underground exposure of radiological irregular opacities in South Wales coal workers with pneumoconiosis. *Brit. J. Indus. Medicine* 1983; 40:169-172.
 6. Dick, J.A., Jacobsen, M., Gauld, S., Pern, P.O.: The significance of irregular opacities in the chest radiographs of British coal miners. In: Proceedings of VI International Pneumoconiosis Conference. Bochum 1983. Geneva International Labour Office, 1984; 283-299.
 7. Castellan, R.M., Sanderson, W.T., Petersen, M.R.: Prevalence of radiographic appearance of pneumoconiosis in an unexposed blue collar population. *Am Rev Respir Dis* 1985; 131:684-686.
 8. Amandus, H.E., Althouse, R., Morgan, W.K.C., Sargent, E.N., Jones, R.: The morbidity and mortality of vermiculite miners and millers exposed to remolite-actinolite: Part III. Radiographic findings. *Am. J. Indus. Med.* 1987; 11:27-37.
 9. Collins, H.P.R., Dick, J.A., Bennett, J.G., Pern, P.O., Rickards, M.A., Thomas, D.J., Washington, J.S., Jacobsen, M.: Irregularly shaped small shadows on chest radiographs, dust exposure, and lung function in coalworkers' pneumoconiosis. *Brit. J. Indus. Med.* 1988; 45:41-55.
 10. Weiss, W.: Cigarette smoking and diffuse pulmonary fibrosis. A preliminary report. *Arch. Environ. Health* 1967; 14:564-568.
 11. Weiss, W.: Cigarette smoking and diffuse pulmonary fibrosis. *Am. Rev. Respir. Dis.* 1969; 99:67-72.
 12. Weiss, W.: Cigarette smoking, asbestos, and pulmonary fibrosis. *Am. Rev. Respir. Dis.* 1971; 104:223-227.
 13. Carilli, A.D., Kotzen, L.M., Fischer, M.J.: The chest roentgenogram in smoking females. *Am. Rev. Respir. Dis.* 1973; 107:133-136.
 14. TGheriault, G.P., Peters, J.M., Johnson, W.M.: Pulmonary function and roentgenographic changes in granite dust exposure. *Arch. Environ. Health* 1974; 28:23-27.
 15. Weiss, W.: Pleuropulmonary disease among asbestos workers in relation to smoking and type of exposure. *J. Occup. Med.* 1978; 20:341-345.
 16. Medical Research Council 1966. Medical Research Council's committee on research into chronic bronchitis: Instructions for the use of the questionnaire on respiratory symptoms. Medical Research Council, London.
 17. Zar, J.H.: Biostatistical Analysis. Prentice-Hall, Inc., 1974.
 18. McNemar, Q.: Psychologic Statistics. Fourth edition. New York: Wiley, 1969.
 19. Witten, D.M.: The Breast. First edition. Chicago: Year Book Medical Publishers Inc., 1969.
 20. Gershon-Cohen, J.: Atlas of Mammography. First edition. New York: Springer-Verlag, 1970.
 21. Epstein, D.M., Miller, W.T., Bresnitz, E.A., Levine, M.S., Gefter, W.B.: Application of ILO Classification to a population without industrial exposure: Findings to be differentiated from pneumoconiosis. *Am. J. Radiol.* 1984; 142:53-58.

PULMONARY EFFECTS OF ACUTE EXPOSURE TO SULFUR TETRAFLUORIDE DURING ELECTRICAL CABLE REPAIR WORK

ALLEN KRAIG, M.D. • Ruth Lillis, M.D.

Division of Environmental and Occupational Medicine
Mount Sinai Medical Center, New York, NY, USA

ABSTRACT

Six electrical workers were accidentally exposed to sulfur tetrafluoride (SF₄) while repairing an electrical cable in an underground confined space. Repairs began 4 days after a burnout at a nearby substation. Symptoms noted approximately 1 hour after beginning work were shortness of breath, chest tightness, productive cough, nose and eye irritation, and headache. Some workers also experienced fatigue, nausea, and vomiting. Partial resolution of symptoms occurred when exposure was interrupted while attempts to identify the cause of the problem were made. Although exposure ended after several hours, 4 workers remained symptomatic for over one week. Chest radiographic abnormalities included, several discrete areas of transitory platelike atelectasis in 1 worker, and soft hazy infiltrates in another. Pulmonary function changes included reversible decrements in FVC and FEV₁.

Sulfur hexafluoride (SF₆), an inert gas, used in circuit breakers as an electrical arc-interrupting medium, decomposes to SF₄ and other compounds when subjected to intense heat. SF₄, an irritant gas, with toxic effects similar to phosgene, was eventually identified by mass spectrometry of worksite air samples, and is the likely cause of the illness developed by these workers. Effects of SF₄ exposure on humans have not been reported in the medical literature, although available information indicates that it is a highly irritant compound. Occupational health personnel should be aware that exposure to SF₄ is an important health hazard for workers repairing damaged electrical systems containing SF₆.

INTRODUCTION

Unpredicted exposures to industrial chemicals place workers at serious risk, as they are both unprepared for the event and may not know the compound's toxic effects. We wish to report the consequences of an unexpected, unpredicted, and unrecognized exposure to the irritant gas, sulfur tetrafluoride (SF₄). The exposure occurred after initiation of repairs following a burnout (small explosion) in an electrical substation. During the burnout circuit breakers using sulfur hexafluoride (SF₆) as an insulating gas were damaged. When SF₆ is subjected to intense heat it decomposes to SF₄ and other compounds.¹ Although SF₄ has been reported to have toxicity similar to that of phosgene,² we could find no published documentation of illnesses in humans caused by this compound.

CIRCUMSTANCES OF EXPOSURE AND ACUTE SYMPTOMS.

On January 12th 1988 approximately 15,000 gallons of polybutene insulating oil was lost from an electrical transmission cable. Concurrently, a burnout occurred in circuit breakers at a substation several miles further down the line. Four days later a team of six gas operators (workers #1-6) began repair work approximately 100 yards from the substation by cutting the surrounding pipe to gain access to the

enclosed electrical cable. The worksite was an underground space, 10' x 4' x 8', with two three foot diameter openings. Four members of the crew (#1-4) worked underground, while the safety officer, (#5), remained on the surface. The foreman, (#6), worked above or below ground as needed. All workers were previously healthy, except for (#5) who had a history of emphysema.

Prior to entering the worksite, routine measurements for natural gas and oxygen concentrations were found to be satisfactory. At approximately 9:00 AM the team began using compressed air powered smith cutters to open the pipe. About one hour later, five underground workers began experiencing burning eyes, tearing, dry and burning throat, and chest tightness. An odor similar to a "burning car battery" was noticed. The crew stopped working and went above ground; symptoms decreased fifteen minutes later.

A fan was obtained to improve air circulation at the worksite. The previously mentioned symptoms, however, recurred shortly after work was resumed. In addition, some workers started experiencing headache, fatigue and cough productive of clear sputum. Concern was raised that the air compressor was the cause of the problems. Work was again halted and a different compressor ordered. Symptoms subsided when the men stopped working underground and went into

the fresh air. Nevertheless, the same symptoms recurred one hour after work was resumed with the new compressor.

Due to the persistence and worsening of symptoms a worksite investigation was performed by the company chemist at approximately 3:00 PM. No abnormalities were detected on routine air monitoring and samples from the partially opened pipe were taken for analysis. Although no problems were identified, a second fan was brought to improve the air circulation. Two hours later workers again reported chest tightness and/or shortness of breath. Two complained of headache, fatigue and nose bleeds; two felt nauseous and one worker vomited. Work was again halted and the entire crew waited above ground for the chemist's final report. At 10:00 PM workers were sent home as the report had not yet arrived.

At approximately 1:00 AM all six workers were notified by telephone that SF₄, a potentially hazardous material, was identified in the air samples taken from the partially opened pipe at the worksite. In addition they were instructed to immediately go to the nearest hospital emergency room. Five of the workers went to one hospital and the sixth to another. Oxygen was administered by mask in the emergency room of the first hospital. Chest radiographs were not taken until approximately 11:00 AM, approximately 26 hours after the onset of exposure. Five of the workers were discharged a few hours later.

Worker #1, complained of headache, cough productive of blood streaked sputum, and wheezing. Three discrete areas of atelectasis were observed on chest radiograph. He was admitted to hospital and treated with bronchodilators and antibiotics. Pulmonary function testing (PFTs) performed January 19th were normal. While in hospital he became febrile. The headache and productive cough persisted for over one week.

All six workers elected to come to the Occupational Medicine Center at the Mount Sinai Hospital for evaluation between January 26 and February 1, 1988. Initial and persistent symptoms are summarized in Table I. Three workers, (#2-4), complained of fatigue at the time of evaluation. Physical examination did not reveal any pertinent abnormalities.

On reviewing the initial radiographs, worker #3 had hazy infiltrates in the lower lung fields, while worker #6 had a slight infiltrate in his left lower lung field. All follow-up radiographs taken between 10-21 days after the accident were normal.

Pulmonary function testing was not performed during the initial emergency room evaluation. PFTs were ordered by the company physician between three and ten days after the event for five of the six workers, the sixth a few days later. Three of these were normal. Workers #5 and 6 had slight

Table I
Symptoms of Workers Exposed to Sulfur Tetrafluoride

Symptom	Worker					
	#1	#2	#3	#4	#5	#6
Burning/ Tearing eyes		*	*	*	*	*
Nasal irritation/ Epistaxis	o		o	o		
Throat irritation	*			*		o
Chest tightness/ Wheezing/ S. O. B.	*	*	o	o		*
Cough	o	*	*			
Nausea/Vomitting	*	*				
Fatigue		o	o	o		
Headache	*		o			

* Symptoms following exposure

o Symptoms lasting longer than one week

decreases in FVC, 75% and 77% percent of predicted, which normalized to 89 and 98% on follow-up testing a few days later. PFT results are summarized in Table II. Interpretation of these findings is limited by the fact that different equipment was used at each location.

Worker #3 had three sets of PFTs, the first set performed on January 19, 1988 was normal. PFTs taken prior to resuming work one week after the event, revealed an obstructive pattern, FVC 109% and FEV₁ 67% of predicted. He did not have a history of asthma, but did complain of chest tightness and shortness of breath on exposure to cold air for approximately one week following the exposure. Repeat testing when he was asymptomatic was normal. DLCOs were normal in all workers except for #5 who had a history of asbestos exposure and emphysema.

DISCUSSION

SF₆ was first synthesized by Moissen and Lebeau in 1902 by burning sulfur in a fluorine atmosphere.³ SF₆ has been used in electrical equipment in the United States since 1953.⁴ It is a heavy, colorless, odorless gas of high chemical stability. By being an effective electron scavenger SF₆ can efficiently retard electrical conduction. These properties have led to its use as an electrical insulating material in circuit breakers, cables, capacitors, and transformers.⁵ SF₆ containing equipment has allowed the creation of compact electrical substations requiring one twentieth the land of previous designs.⁶

The use of SF₆ has increased markedly in recent years. The National Occupational Hazard survey initiated in 1971, ap-

Table II
Pulmonary Function Results

Worker [^]				
#3	Date FVC FEV1 FVC/FEV1 FEF25-75 DLCO	Jan. 19* 4.15 3.7 89%	Jan. 26 ' 4.40 (109%) 2.08 (67%) 47% 2.00 (62%)	Feb. 1" 4.87 (116%) 3.92 (120%) 80% 2.69 (81%) 38.1 (141%)
#5	Date FVC FEV1 FVC/FEV1 FEF25-75 DLCO	Jan. 19 ' 3.58 (77%) 2.17 (60%) 60% 1.08 (34%)	Jan. 28 " 4.52 (98%) 2.71 (78%) 64% 1.50 (33%) 16.2 (60%)	
#6	Date FVC FEV1 FVC/FEV1 FEF25-75 DLCO	Jan. 21 ' 3.64 (75%) 3.28 (87%) 90% 5.96 (160%)	Jan. 26 " 4.23 (89%) 3.97 (107%) 94% 7.66 (153%) 24.3 (82%)	

- * Private Physician's office
 - ' Company medical facility
 - " Mount Sinai Medical Center
 - [^] Workers #1,2,4 all had unchanged results on repeat testing
- Percentages in parenthesis are % predicted

proximated that 177 American workers were potentially exposed to this compound.⁷ Preliminary information from the early 1980's estimates over 9,000 potentially exposed workers, over half repairers of electrical and electronic equipment.⁸

SF₆ is an inert gas; in experimental studies no ill effects were found in mice breathing a mixture of 80% SF₆ and 20% O₂ for 12–16 hours.² SF₆ will break down to toxic sulfur oxyfluorides during electrical arcing in the presence of oxygen.^{1,9} Worker exposure to these gases can be significantly reduced by the presence of properly maintained absorptive filters. In experiments specifically designed to identify the decomposition products of SF₆, SF₄ was only generated by higher energy arcs after the consumption of available oxygen.¹ Temperatures above 150°C have been reported to lead to the decomposition of SF₆ to SF₄ and other compounds.¹⁰

SF₄, a highly reactive, colorless gas which fumes in moist air, has an irritating odor similar to sulfur dioxide.¹¹ No comprehensive studies of this compound's toxicity could be found in the medical literature. The material safety data sheet on this compound reports it to be extremely irritating and corrosive to the upper and lower respiratory tracts, skin, and eyes.⁹ SF₄ hydrolyses in air to form hydrofluoric acid. Thus skin and mucous membranes lesions similar to those caused by this acid can be expected in workers exposed to SF₄. SF₄ may cause chemical pneumonitis and pulmonary edema.⁴ Animals exposed to 10 ppm SF₄ for one hour developed rapid labored breathing, weakness, and cyanosis.¹² The manufacturer has reported that animals exposed to 50 ppm for 4 hours died from pulmonary edema.¹³ Ten repeated exposures of 4 ppm for 4 hours produced signs of respiratory effects in rats. Pulmonary damage was observed in rats sacrificed immediately after the tenth exposure. Those subsequently unexposed for 14 days recovered clinically and showed no anatomical lesions.¹⁴ In 1959 investigators for E.I. Du Pont de Nemours & Company recommended that SF₄ should be treated with extreme caution as it has an inhalation toxicity comparable to phosgene.² Consistent with this high level of toxicity the ACGIH has set a ceiling exposure limit of 0.01 ppm for this compound.¹⁵

Electrical substations contain switches, circuit breakers, conductors, and transformers to switch power circuits and transform power from one voltage to another or from one system to another. At the station in question three circuit breakers were connected to the damaged cable. Each of these were approximately the size of a 55 gallon drum and filled with SF₆.

Although the exact sequence of events leading to the SF₄ exposure has not been determined, a likely sequence is as follows. Due to damage at a distant site insulating oil was lost from the cable. This, or the following burnout led to a disruption of the valve separating the circuit breakers from the cable. Due to the intense heat of the burnout SF₆ decomposed and all oxygen in the system was consumed. Further breakdown of SF₆ occurred leading to the production of SF₄ and possibly other compounds. As the circuit breakers were not externally damaged the SF₄ was forced into the pipe containing the cable and was released when the pipe was cut

at the worksite. Although other breakdown products may have been present, SF₄ was the only one qualitatively identified. The level of exposure was not quantified. Repeat testing the following day revealed barely detectable levels.

Workers were exposed to SF₄ for about 6 hours over a 12 hour period while repairing the cable. Chest radiographs were not taken until 26 hours after the start of exposure. In addition any early PFT changes may have been missed as testing was not performed until a few days after the event when the majority of acute symptoms had already subsided.

Radiographic evidence of multilobar atelectasis was present in one worker. In addition a second worker, who did not have a previous history of asthma, complained of chest tightness on exposure to cold air and developed a transitory obstructive pattern on pulmonary function testing. His chest radiograph revealed hazy infiltrates in his lower lung fields. These findings are consistent with known toxic effects of irritant gas exposure.

All five underground workers had respiratory tract symptoms, the sixth worker who remained above ground, experienced only eye irritation. The intermittent nature of the exposure most probably prevented the development of more severe effects such as chemical pneumonitis or toxic pulmonary edema.

These workers were unaware that their job could lead to exposure to SF₄. Although they had worked for many, some for over twenty years in this field, none had heard of SF₄ before or were aware that their job may lead to exposure to irritating chemicals in general and to SF₄ in particular. Had they, or the company management, physician, chemist, or industrial hygienists been aware of the potential for this exposure, it is likely that the exposure would have been of much shorter duration. The potential for toxic exposures, however, is documented in the material safety data sheet describing SF₆.⁹ Proper education may have prevented the adverse health effects suffered by these workers.

Although the presence or absence of odor should not in general be relied upon to identify toxic exposures, odors present in areas containing heated SF₆ must be considered to be coming from decomposition products and be a signal for the use of proper safety procedures.^{1,4} An odor similar to a "burning car battery" was identified by workers, but no one involved in the initial investigation recognized this to be a warning signal. Fortunately, no worker developed severe complications and all have been able to return to work.

In order to limit the potential adverse effects of a similar event in the future, the following recommendations were given to both workers and management:

1. Comprehensive air tests be conducted before work is begun after accidents.
2. Knowledgeable individuals should be available for immediate on site consultation if needed.
3. If a problem is presumed to exist work should not be resumed until the evaluation has been completed.
4. Proper respiratory protective equipment should be available at the worksite.

Due to the expanding role of SF₆ in the electrical transmission industry¹⁶ it is likely that exposures to its decomposition products will occur in the future. Occupational health personnel should thus be aware that exposure to SF₄ is an important health hazard for workers repairing damaged electrical systems containing SF₆.

REFERENCES

1. Boudene, C., Cluet, J.L., Kreb, G., and Wind, G.: Identification and study of some properties of compounds resulting from the decomposition of SF₆ under the effect of electrical arcing in circuit breakers. *Revue Generale de l'electricite*. 185:45-78 (1974).
2. Smith, W.C., Tullock, C.W., Muetteries, E.L., Hosek, W.R., Fawcett, F.S., Engelhardt, V.A., and Coffmann, D.D.: *American Chemical Society Journal*. 81:3165-66 (1959).
3. Moissen, H. and Lebeau, P.: Etude des Fluorures et Oxyfluorides de Soufre. *Ann. Chim. Phys.* 26:145-178 (1902).
4. Amalric, J., Fallou, M., Mazingarbe, E., Tellier, R., and Vigreux, J. Practical consequences of research on the decomposition by arc of SF₆. *Revue Generale de l'electricite*. 185:78-85 (1974).
5. *Kirk-Othmer Encyclopedia of Chemical Technology*, 3rd Ed., Vol. 10 pp. 799-811. M. Grayson, Ed. John Wiley and Sons, New York 1980.
6. *Standard Handbook for Electrical Engineers*, 12th Ed., pp. 17.1-17.51. D.G. Fink and H.W. Beaty, Eds. McGraw, New York (1987).
7. *National Occupational Exposure Survey*, National Institute for Occupational Safety and Health DHEW (NIOSH) Publication No. 78-114. Cincinnati (1978).
8. *National Occupational Hazard Survey*. National Institute for Occupational Safety and Health DHEW (NIOSH) (pending).
9. *Air Products Specialty Gas Material Safety—Safety Sheet Sulfur Hexafluoride*. Air Products and Chemicals, Inc. Allentown, Pa. (1986).
10. *Kirk-Othmer Encyclopedia of Chemical Technology*, 3rd Ed. ** Vol. 13 pp. 534-564. M. Grayson, Ed. John Wiley and Sons, New York (1980).
11. *Information Profiles on Potential Occupational Hazards: Sulfur Tetrafluoride*, Center for Chemical Hazard Assessment, Syracuse Research Corporation Report No. SRC TR 81-549. Syracuse N.Y. (1981).
12. *Documentation of the Threshold Limit Values for Substance in Workroom Air*. 3rd Ed., American Conference of Government Industrial Hygienists. Cincinnati, OH (1979).
13. *Sulfur Tetrafluoride, Bulletin #C174BUB-0*. Air Products and Chemical, Inc. Allentown, PA. (n.d.)
14. Clayton, J.W. The toxicity of fluorocarbons with special reference to chemical constitution.: *J. Occ. Med.* 4:(5)262-273. (1962).
15. *Threshold Limit Values and Biologic Exposure Indices for 1987-1988*. American Conference of Governmental Industrial Hygienists. Cincinnati, OH. (1987).
16. *The State of International Development and Experience with SF₆ Insulated High Voltage Switchgear, Session 23.01*. International conference on large high voltage electrical systems (CIGRE), Paris, (1982).

EXPERIMENTAL STUDIES ON THE EFFECT ON THE IMMUNE SYSTEM OF EXPOSURE TO COALMINE DUST AND QUARTZ.

Y. KUSAKA, M.D. • R. T. Cullen, Ph.D • K. Donaldson, Ph.D

Institute of Occupational Medicine 8
Roxburgh Place, Edinburgh EH8 9SU

INTRODUCTION

Immune effects of mineral dusts may influence the development and progression of pneumoconiosis. In coalworkers' pneumoconiosis, progressive massive fibrosis and Kaplan's Syndrome are said to be related to immunologic abnormalities.¹ In addition, experimental studies have revealed that fibrogenic mineral dust alter immune responses.^{2,3}

As part of a programme to examine the effect of silica and coalmine dust on the immune system, two approaches were taken: firstly immunocompetent cells from the rat spleen were exposed to dust *in vitro* and their mitogenic responses were assessed; secondly, dusts were intratracheally administered to rats and the effects of elicited bronchoalveolar leukocytes on splenocyte mitogenesis were studied.

MATERIALS AND METHODS

Animals

Twelve to fifteen-week old, female, SPF-maintained, inbred PVG rats were supplied by the Institute of Occupational Medicine breeding unit.

Dusts

Four kinds of dusts were used in the experiments: two were coalmine dusts collected from the air of British collieries mining 1) anthracite coalmine dust (A) and 2) low rank coalmine dust (L), 3) titanium dioxide (TiO₂; rutile, Ti oxide Ltd. Stockton on Tees), a dust of low biological activity, 4) quartz dust (DQ12 standard).

Splenocyte Mitogenesis

Rats were killed by intraperitoneal injection with Nembutal and spleens were aseptically removed and disaggregated with a glass homogenizer. After lysing the erythrocytes, splenocytes were suspended in Hepes-buffered RPMI 1640 medium supplemented with 50mM 2-Mercaptoethanol, 2mM glutamine, 100mg/l kanamycin and 10% fetal calf serum (cRPM1). Finally 2×10^5 splenocytes, in medium were delivered to each well of 96-well microtiter plates.

The splenocytes, with or without dust suspensions, supernatant or bronchoalveolar cells, were cultured in the presence or absence of a suboptimal dose of phytohemagglutinin (PHA, 10 µg/ml) for three days at 37°C in 5% CO₂. The cultures were then pulsed with 0.25µCi tritiated thymidine,

incubated overnight, and the uptake of ³H Thymidine was determined by liquid scintillation counting.

Effect of Dusts on Splenocyte Mitogenesis

The four kinds of dusts were autoclaved and suspended in cRPMI. Each aliquot was added to splenocytes to obtain a final concentration in the well of 10, 50 or 100 µg/ml. They were then co-cultured at 37°C in 5% CO₂ for 24 hours and stimulated with suboptimal PHA for a further three days in culture. A preliminary study showed that 24 hours of co-culture of the splenocytes with dusts led to the optimal response to PHA. The cultures were assessed for mitogenesis as described above.

Effect of Supernatants on Mitogenesis

Splenocytes were adjusted to 1×10^6 cells/ml and aliquots of 5ml were delivered to plastic flasks. The splenocytes were allowed to adhere for six hours (adherence efficiency $27 \pm 10\%$, $\bar{x} \pm \text{sd}$) and non-adherent cells were removed by washing. The adherent splenocytes were cultured with dusts at a final concentration of 100 µg/ml for 24 hours and supernatants were collected which were spun, filtered and frozen until use. The supernatants, at various dilutions were delivered to wells containing 2×10^5 splenocytes and these were cultured and harvested as described above.

Interleukin-1 Activity in Spleen Cell Supernatants

Three-fold dilutions of supernatants from cultures of adherent spleen cells exposed to dust at 100 µg/ml, were incubated with C3H mouse thymocytes at 6×10^5 per well in microtiter plates. PHA was added at a final concentration of 4 µg/ml and the plates cultured for 72 hours. Thymocyte proliferation was determined by the incorporation of tritiated thymidine added during the final 16 hours of culture. Supernatant from unfractionated spleen cells cultured with 10 µg/ml Concanavalin A (Con A) served as a positive control. Con A activity was neutralized with methylmannoside before use in the thymocyte assay.

Effect of Bronchoalveolar Leukocytes from Dust-Exposed Rats on Splenocyte Mitogenesis

Rats were intratracheally instilled with 1mg of the four different kinds of dusts suspended in 0.5ml Phosphate Buffered Saline (PBS). PBS alone was injected into rats as a control. Bronchoalveolar cells (BAC) were obtained by lavage seven days later. BAC were washed with RPMI1640 and sus-

pended in cRPMI. BACs from quartz-treated rat were separated into a macrophage and neutrophil-enriched populations by density gradient centrifugation through Septra-cell medium. Total and differential counting was done on Diff-quick stained cytospin preparations and viability was assessed by trypan blue exclusion. Total or separated BACs were added to splenocytes at final ratios of from 1:4 to 1:128. The cultures were incubated and assessed for mitogenesis as above.

Statistical Analysis

Since variation between experiments was large, the data were expressed as mitogenic indices for each condition: the mitogenic indices were obtained by dividing the suboptimal PHA-driven splenocyte mitogenesis with dust, supernatant or bronchoalveolar leukocytes, by the mitogenesis without these treatments. The differences in mean values of mitogenic indices between treated and untreated were tested by paired t-test. The differences were considered as significant if values were less than 0.05. In the IL-1 assay, the ³H uptake by the cultures with various supernatants were compared to those with control supernatant (no dust treatment).

RESULTS

Effect of Dusts on Splenocyte Mitogenesis *In Vitro*

Both quartz at 10, 50 or 100 µg/ml and low rank coalmine dust L at 50 and 100 µg/ml significantly enhanced mitogenesis. Quartz especially augmented splenocyte proliferation even without mitogen (data not shown). On the contrary, both TiO₂ and coalmine dust A suppressed splenocyte proliferation in a dose-dependent manner (Figure 1).

Effect of Supernatant from Dust-Exposed Adherent Splenocytes on Mitogenesis

The supernatant, tested at various dilutions did not cause enhancement of mitogenesis and, in fact, supernatant from splenocytes treated with quartz at a high dose were inhibitory to mitogenesis (typical results of 1:16 dilution shown in Figure 2).

Interleukin-1 Activity in Supernatants

Despite the lack of enhancement in the spleen cell mitogenesis assay, the thymocyte assay did show interleukin 1-like activity in the quartz supernatant diluted at 1:7.5 (Figure 3).

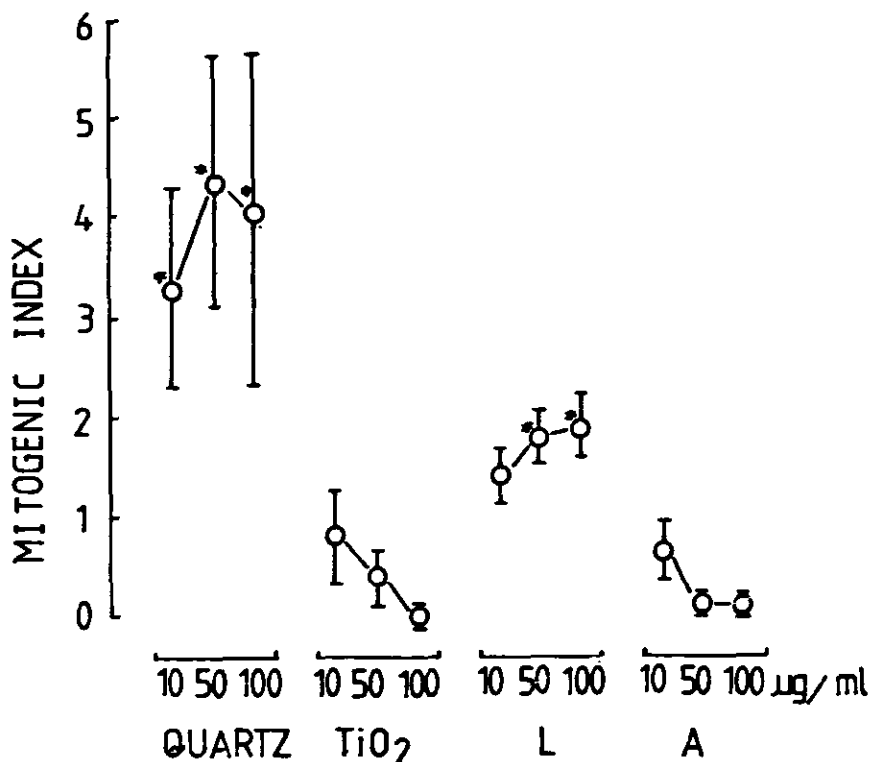

Figure 1. Mitogenic indices (means with standard errors) of splenocytes cultured with four kinds of dusts. Mitogenic index derived as the ratio of mitogenesis with dust:mitogenesis without dust. An asterisk denotes a significant (p<0.05) difference from the control.

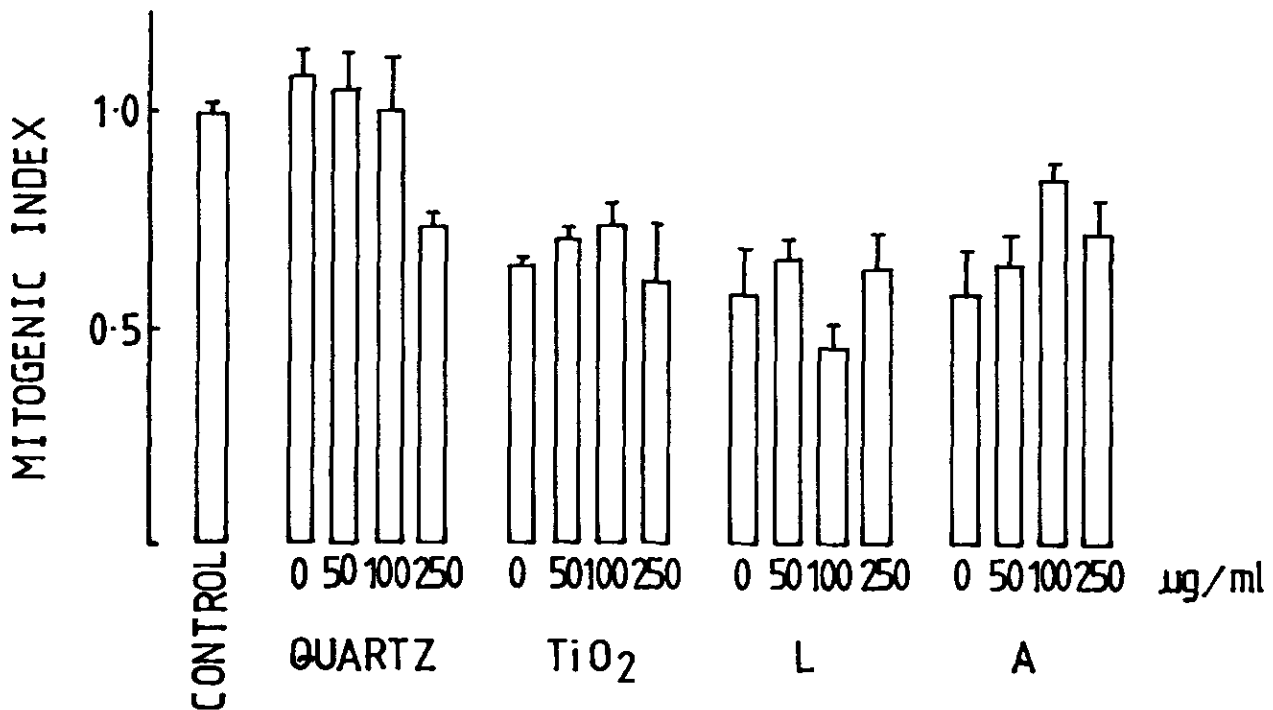

Figure 2. Effects of supernatants from dust-exposed adherent splenocytes on mitogenesis. Data are shown as mitogenic indices (means with standard deviations). Mitogenic index derived as the ratio of mitogenesis with supernatant from dusted or not-dusted adherent splenocytes:mitogenesis without supernatant.

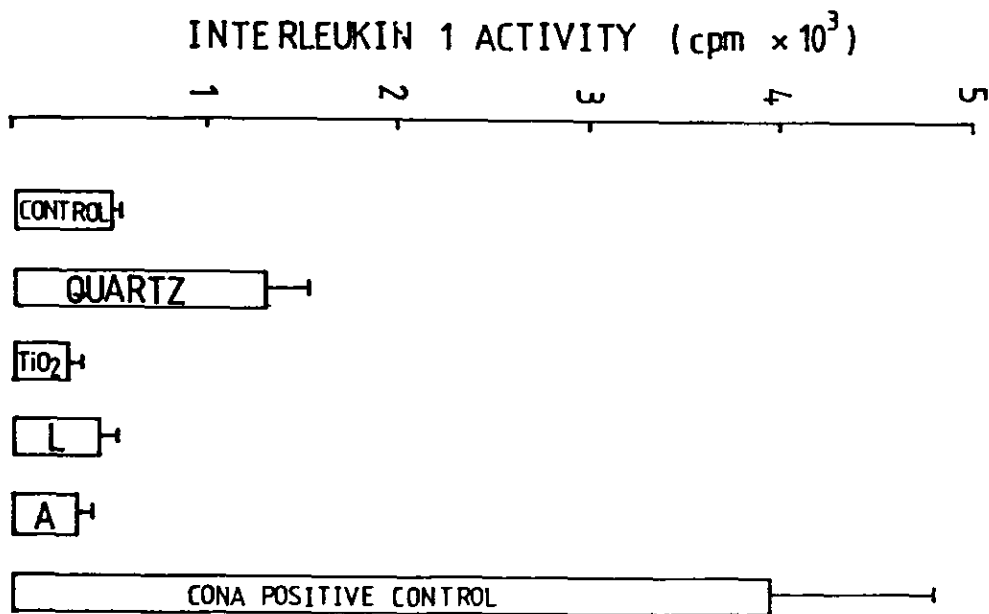

Figure 3. Interleukin 1 activity in supernatants from dust-exposed adherent splenocytes. An asterisk denotes a significant ($p < 0.05$) difference from the control supernatant.

Higher concentrations of supernatant were inhibitory and supernatant from spleen adherent cells treated with other dust had no detectable IL-1 activity.

Effect of Bronchoalveolar Leukocytes from Dust-Exposed Lungs on Mitogenesis

Control, PBS-elicited bronchoalveolar leukocytes (total $4.16 \pm 0.33 \times 10^6$ ($\bar{x} \pm sd$) cells per rat, macrophages >98%, viability >95%) showed an inhibitory effect on splenocyte mitogenesis which was effector:indicator cell ratio-dependent. The bronchoalveolar leukocytes from coal dust L (total $3.08 \pm 0.76 \times 10^6$ cells per rat, macrophages $96 \pm 2\%$, neutrophils $3 \pm 2\%$, viability >91%), coalmine dust (A) (total $2.58 \pm 0.33 \times 10^6$ cells per rat, macrophages >99%, viability >92%) or TiO_2 (total $4.61 \pm 0.33 \times 10^6$ macrophages >99%, viability >93%) did not affect mitogenesis. Figure 4 shows the results for BAC from coalmine dust A.

The BAC from quartz-treated rats (total $16.83 \pm 4.64 \times 10^6$ cells per rat, macrophages $42 \pm 4\%$, neutrophils $57 \pm 4\%$) was significantly less inhibitory to splenocyte proliferation, at ratios of 1:64, 1:32 and 1:16, than the control. After the separation into macrophage- and neutrophil-enriched fractions (recovery rate $60 \pm 1\%$), the macrophage-enriched population (macrophages $89 \pm 5\%$) also showed less inhibition at ratios of 1:64 and 1:32. In contrast to the inhibitory

effect of the total leukocytes or separated macrophages, the neutrophil-enriched population (neutrophils $82 \pm 2\%$) markedly enhanced mitogenesis compared to control BAC (Figure 5).

DISCUSSION

In our rat model system, we have examined the effects of exposure to mineral dusts on the immune system. The splenic lymphocytes were taken as indicator cells for the direct effect of dust on the immunomodulatory role of leukocytes within the lung.

Both quartz and coalmine dust with a high (>5%) quartz component, enhanced splenocyte mitogenesis *in vitro*. Supernatant from adherent splenocytes, presumed to be mostly macrophages, treated with quartz showed increased IL-1 activity, whilst supernatant from coalmine dust or TiO_2 -treated macrophages had no such activity. None of these supernatants caused enhanced mitogenesis. These apparently conflicting findings may be explained as follows. Adherent macrophages secrete, in addition to IL-1, a variety of substances including prostaglandins and hydrogen peroxide, which are inhibitory to lymphocyte proliferation.^{4,5} Subsequently the ability of any supernatant to influence mitogenesis is likely to be the product of both the inhibitory and enhancing activity present in it. Evidence that inhibitory factors were present, and could be diluted out was

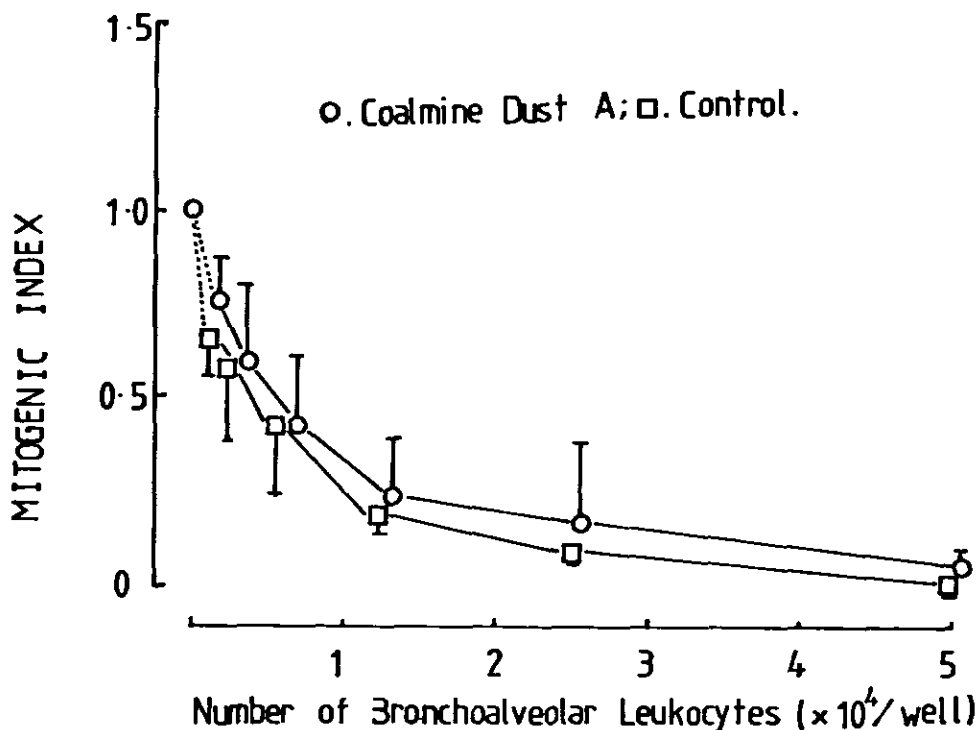

Figure 4. Bronchoalveolar leukocytes from coalmine dust L-instilled rats inhibited splenocyte mitogenesis in a dose-dependent manner. No significant differences from control leukocytes were present. Mitogenic index derived as the ratio of mitogenesis with bronchoalveolar leukocytes:without leukocytes.

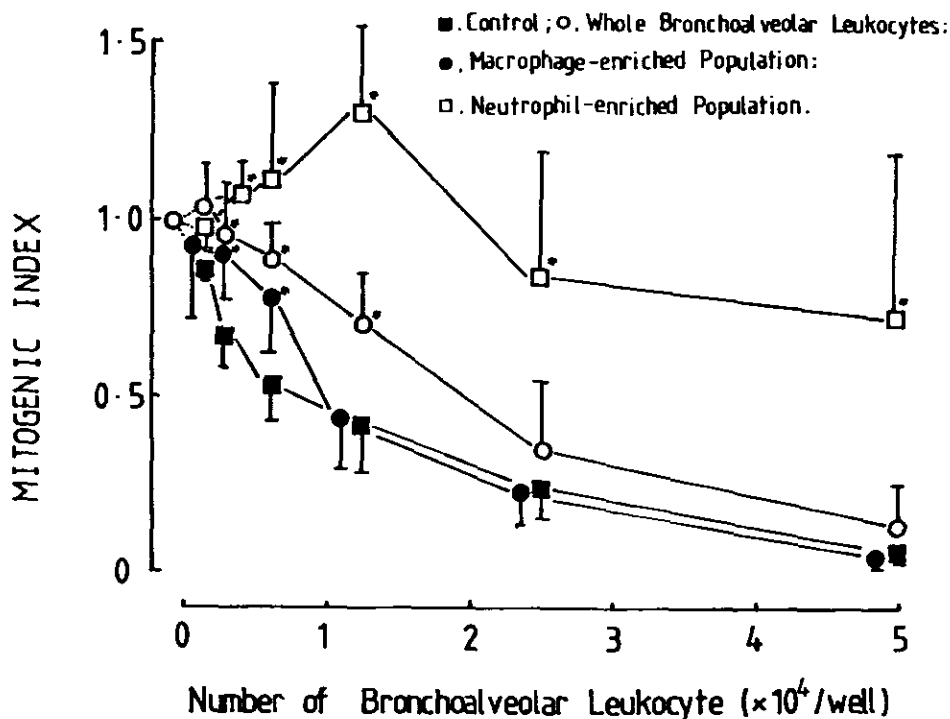

Figure 5. Effects of bronchoalveolar leukocytes from quartz-injected rats on splenocyte mitogenesis. Data are shown as mitogenic indices (means with standard deviations). An asterisk denotes a significant difference ($p < 0.05$) from controls treated with PBS.

shown by the fact that IL-1 activity in the supernatant from quartz-exposed splenocytes was expressed only at higher dilutions. Further studies are needed to elucidate the mechanism of enhanced mitogenesis by quartz and low rank coalmine dust *in vitro* including further characterization of the secreted product present in supernatant from dust-treated macrophages.

Alveolar macrophages are situated at the air-tissue interface, strategically located for initial contact with inhaled particulates. They also play a crucial role in pulmonary immune responses. Alveolar macrophages in some species including rats are said to be poor accessory cells for mitogen or antigen-derived lymphocyte proliferation.⁶ In our study normal bronchoalveolar macrophages inhibited splenocyte mitogenesis in a dose-dependent manner. TiO_2 and two kinds of coalmine dusts did not affect this down-regulatory function of alveolar macrophages. However the whole BAC and the alveolar macrophage-enriched population from quartz-treated rats inhibited lymphocyte response to a lesser extent than control BAC although this may be due to contaminating neutrophils as described below. Further studies are needed to confirm whether alveolar macrophages elicited by exposure to quartz have altered immunomodulatory properties, as suggested by this study.

The neutrophils separated from quartz BAC strikingly enhanced mitogenesis and this could be mediated through protease⁷ or an IL-1 analogue which has been described in secretions from peritoneal neutrophils.⁸

Inhalation exposure to asbestos fiber, another type of fibrogenic dust, causes recruitment of Ia-positive alveolar macrophages and secretion of IL-1 by alveolar macrophages.^{9,10} Additionally, alveolar macrophages from asbestos-exposed rat enhanced T lymphocyte proliferation *in vivo*.¹¹ *In vitro* fibrogenic dust such as asbestos and silica stimulated alveolar macrophages to secrete IL-1.¹² Inhalation exposure to silica also causes secretion of IL-1 by alveolar macrophages when stimulated with endotoxin.¹³ These studies suggest that fibrogenic dusts have immunostimulatory effects on alveolar macrophages and our results partially support these findings. However the complex effect of recruitment of newly exuded, monocyte-derived populations with altered cytokine production and the role of neutrophils, which are also found in dust exposed lung,¹⁴ remain to be resolved.

This study suggests that, in the lungs of individuals inhaling quartz or quartz-containing coalmine dusts, the alveolar macrophages may be affected by phagocytosed dust to release a range of mediators which could modulate lymphocyte responses in the local environment of the lung. Additionally, neutrophils which are recruited into dust-exposed lung could also enhance immune responses leading to localized immunomodulation. Any "adjuvant-type" effect on the immune system could contribute directly to heightened responses within the lung both to dust itself and to infectious agents, both of which could contribute to the tissue injury and fibrosis found in pneumoconiosis.

REFERENCES

1. Morgan, W.K.C., Seaton, A.: *Occupational Lung Diseases*, 2nd Ed., pp. 377-448. W.B. Saunders Co., Philadelphia (1984).
2. Donaldson, K., Davis, J.M.G., James, K.: Asbestos-activated Peritoneal Macrophages Release a Factor(s) which Inhibit Lymphocyte Mitogenesis. *Environ. Res.* 104-113 (1983).
3. Hannant, D., Donaldson, K., Bolton, R.E.: Immunomodulatory Effect of Mineral Dust. I. Effects of Intraperitoneal Dust Inoculation on Splenic Lymphocyte Function and Humoral Immune Responses in vivo. *J. Clin. Lab. Immunol.* 16:81-85 (1985).
4. Bonney, R.J., Humes, J.L.: Physiological and Pharmacological Regulation of Prostaglandin and Leukotriene Production by Macrophages. *J. Leukocyte Biol.* 35:1-10 (1984).
5. Davis, L., Lipsky, P.E.: Signals Involved in T cell Activation. I. Phorbol Esters Enhance Responsiveness but Cannot Replace Intact Accessory Cells in the Induction of Mitogen-stimulated T cell Proliferation. *J. Immunol.* 135:2946-2952 (1985).
6. Holt, P.G.: Alveolar Macrophages. IV. Interspecies Differences in Activity in Proliferating Lymphocyte Cultures. *Cell. Immunol.* 50:210-215 (1980).
7. Nakamura, S., Yoshinaga, M., Hayashi, H.: Interaction between Lymphocytes and Inflammatory Exudate Cells. II. A Proteolytic Enzyme Released by PMNL as a Possible Mediator for Enhancement of Thymocyte Response. *J. Immunol.* 117:1-6 (1976).
8. Goto, F., Nakamura, S., Goto, K., Yoshinaga, M.: Production of a Lymphocyte Proliferation Potentiating Factor by Purified Polymorphonuclear Leukocytes from Mice and Rabbit. *Immunol.* 53:683-692 (1984).
9. Hartmann, D.P., Georgian, M.M., Oghiso, Y., Kagan, E.: Enhanced Interleukin Activity following Asbestos Inhalation. *Clin. Exp. Immunol.* 55:643-650 (1984).
10. Hartman, D.P., Georgian, M.M., Kagan, E.: Enhanced Alveolar Macrophage Ia Antigen Expression after Asbestos Inhalation. *J. Immunol.* 132:2693-2695 (1984).
11. Miller, K., Kagan, E.: Manifestation of Cellular Immunity in the Rat after Prolonged Asbestos Inhalation. *Environ. Res.* 26:182-194 (1981).
12. Oghiso, Y., Kubota, Y.: Interleukin 1 Production and Accessory Cell Function of Rat Alveolar Macrophages Exposed to Mineral Dust Particles. *Microbiol. Immunol.* 31:275-287 (1987).
13. Oghiso, Y., Kubota, Y.: Enhanced Interleukin 1 Production by Alveolar Macrophages and Increase in Ia-Positive Lung Cells in Silica-Exposed Rats. *Microbiol. Immunol.* 30:1189-1198 (1986).
14. Donaldson, K., Bolton, R.E., Jones, A., Brown, G.M., Robertson, M.D., Slight, J., Cowie, H., Davis, J.M.G.: Kinetics of the Bronchoalveolar Leukocyte Response in Rats during Exposure to Equal Airborne Mass Concentrations of Quartz, Chrysotile Asbestos, or Titanium Dioxide. *Thorax.* 43:525-533 (1988).

ACKNOWLEDGEMENT: The research was supported by the Commission of the European Communities. Dr. Y. Kusaka would like to gratefully acknowledge a kind contribution by the Colt Foundation which allowed this work to be completed.

BRONCHOALVEOLAR LAVAGE IN SUBJECTS EXPOSED TO OCCUPATIONAL DUSTS

GEORGE GOODMAN, M.D.* † • Norman L. Lapp, M.D.* • William H. Pailles, M.S.‡
• Daniel Lewis, Ph.D.‡ • Vincent Castranova, Ph.D.‡

*West Virginia University Hospital, Morgantown, West Virginia

†Allegheny General Hospital, Pittsburgh, Pennsylvania

‡Division of Respiratory Disease Studies, NIOSH, Morgantown, West Virginia

INTRODUCTION

Alveolar macrophages are free lung cells located on the surface of small airways and alveoli. These phagocytes play an important role in the protection of the lung against airborne bacteria and particles.¹ However, hyperactivation of pulmonary phagocytes can lead to excessive secretion of enzymes and reactive oxygen species which could result in lung injury, emphysema, or fibrosis.^{2,3}

Analysis of bronchoalveolar lavage effluents for cell types and cellular activity has yielded information concerning the etiology of various pneumoconioses. For example, emphysema associated with inhalation of coal dust or cigarette smoke has been related to enhanced secretion of reactive oxygen species from alveolar macrophages.⁴⁻⁷ In contrast, hypoactivation of alveolar macrophages has been associated with inhalation of diesel particulates⁴ and has been related to increased susceptibility to pulmonary infection.⁸ Inhalation of cotton dust has been associated with dramatic increases in lavagable polymorphonuclear leukocytes⁹ while pulmonary sarcoidosis and silicosis have been related with high numbers of lymphocytes in lavage effluents^{10,11}

The objective of the present study was to obtain lavage effluents from 8 control subjects, 8 healthy power plant workers exposed to fly ash, 1 healthy coal miner, and 1 rock driller with acute silicosis. These effluents were analyzed for total numbers of alveolar macrophages, lymphocytes and neutrophils and for secretory activity of alveolar macrophages. Data were then analyzed to determine what response patterns were characteristic for given dust exposures.

METHODS

Selection of Subjects

The 8 control subjects were all adult males from the area of Morgantown, WV. Two subjects among the controls had smoked cigarettes for approximately three pack-years and had stopped more than ten years ago. The 8 power plant workers were all healthy adult male employees of a power facility in Hatfield, PA, approximately thirty miles from Morgantown. One of the power plant personnel was a comparable ex-smoker. The remaining subjects were all lifelong non-smokers. The coal miner was a healthy non-smoking

male from Morgantown, WV. The rock driller was a patient under treatment with corticosteroids for acute silicosis. He had shown considerable clinical improvement with this treatment but still manifested significant radiologic and pulmonary functional abnormalities at the time of lavage. The mean age of the 8 control subjects was 36 years (range: 31 to 49 years); the mean age of the remaining subjects studied was 38 years (range: 29 to 53 years).

Each volunteer was interviewed prior to participation in the study. Each completed the British Medical Research Council standardized questionnaire concerning respiratory and occupational history. One individual among the controls occasionally used a metered-dose inhaler for the management of mild asthma; otherwise there was no history of significant concurrent respiratory illness among the subjects except for the one with acute silicosis. Other than these two individuals, none of our volunteers received any medications regularly.

None of the control subjects had a history of significant exposure to occupational dusts. The coal miner had worked in underground mines for approximately 20 years and rarely wore a respirator. The power plant employees had variable histories of exposure to dusts at their plant, ranging from 4 to 15 years of employment. Although some of their work brought them into contact with both asbestos and coal dust, the primary dust exposure was to fly ash. None of them wore respirators consistently. The rock driller was exposed to significant levels of sandstone, coal and rock dust over a 12 year period during which time he never wore a respirator.

Experimental Procedures

Protocols were approved by HSRB at West Virginia University. In each subject, pulmonary function tests were obtained (spirometry and diffusion capacity) as well as a 12-lead electrocardiogram, PA and lateral chest x-ray films, and screening blood tests. All of these studies were normal except for the presence of mild obstruction in our one asthmatic control and moderate restriction and reduced diffusion capacity in the patient under treatment for acute silicosis.

Flexible bronchoscopy and bronchoalveolar lavage was performed in a consistent fashion in all subjects.⁵⁻⁷ After the tip of the bronchoscope had been wedged into a distal segment in the right middle or right lower lobe, this area was

lavaged with 10 aliquots of 20 cc of 0.9 saline. The pooled return from the lavage was passed through nylon mesh (150 mesh) to remove mucus from the specimen. The specimen was then centrifuged at 500 g for 5 min. at 2°C, the supernate decanted, and the pellet of cells resuspended in HEPES buffered medium (145 mM NaCl, 5mM KCl, 10 mM HEPES, 1 mM CaCl₂, 5mM glucose; pH:7.4). These cells were then washed twice by alternate centrifugation and resuspension in HEPES-buffered medium.

Total cell counts in the lavage effluent were determined using an electronic cell counter. Lymphocytes, neutrophils, and alveolar macrophages were identified by their distinctive cellular volumes using an electronic cell sizing attachment as described previously.^{12,13}

Chemiluminescence was measured in the presence of 1.7 mg luminol and 8 serum using a Berthold 9505 Luminometer. Chemiluminescence was monitored at rest (Rest CL) and after stimulation with either 3×10^{-6} M phorbol-12-myristate acetate (PMA-CL) or 2 mg/ml zymosan (Zym-CL). Chemiluminescence was expressed as total counts per second/10 min/ 1.63×10^6 alveolar macrophages.

RESULTS

The data are shown in Table I. Fly ash exposure resulted in significant increases in lavagable alveolar macrophages, lymphocytes, and neutrophils compared to controls. In addition, zymosan-stimulated chemiluminescence was significantly elevated while resting CL and PMA-CL exhibited a trend toward elevation. Coal dust exposure resulted in only a slight increase in resting chemiluminescence. In contrast, neither PMA-CL or Zym-CL was enhanced. The most striking changes were observed in acute silicosis where very large increases in lymphocytes, neutrophils, resting CL, PMA-CL, and Zym-CL were noted.

DISCUSSION

Our data indicate significant differences in alveolar cell populations and phagocytotic activity when asymptomatic occupationally-exposed individuals are compared with controls. Subjects exposed to fly ash exhibited significant pulmonary inflammation, i.e., their bronchoalveolar lavage contained approximately twice the number of macrophages, lymphocytes, and neutrophils as controls. In addition, phagocytotic activities as measured by chemiluminescence were all increased, with the activity after zymosan stimulation being significantly enhanced.

No significant activation of alveolar macrophages was noted after coal dust exposure. This contrasts with coal-induced activation noted in animal studies.⁴ Clearly more coal miners are needed before definitive conclusions can be drawn.

The acute silicotic exhibited the most striking changes. Lavagable cells were elevated by 32% for alveolar macrophages, 14.6 fold for lymphocytes, and 10.5 fold for neutrophils. Similar increases in lymphocytes and neutrophils due to silica exposure have been reported previously in both rats and humans.^{14,11} These observations are more dramatic when one considers that this subject had been on corticosteroid therapy prior to lavage. Indeed, such treatment would tend to decrease the yield of lavagable cells.¹⁵ The high levels of chemiluminescence seen in the silicotic patient (i.e., Rest CL increased 5.3 fold, PMA-CL increased 3.7 fold, and Zym-CL increased 12.4 fold) suggest that a substantial oxidant burden exists in the lungs of this subject. Oxidant injury could explain the restrictive lung disease and diminished diffusion capacity observed in this patient.

CONCLUSION

We present data on bronchoalveolar lavage in normal control subjects and individuals occupationally exposed to in-

Table I
Characterization of Bronchoalveolar Lavage

<u>Parameter</u> ¹	<u>Controls</u> (mean \pm SEM)	<u>Fly Ash</u> (mean \pm SEM)	<u>Coal Dust</u>	<u>Acute Silicosis</u>
# Alveolar macrophages	7.4 \pm 1.2	14.1 \pm 2.1*	4.0	9.8
# Lymphocytes	4.5 \pm 0.8	8.4 \pm 1.1*	4.6	65.6*
# Neutrophils	2.9 \pm 0.7	7.3 \pm 2.5*	3.1	30.3*
Rest CL	27.0 \pm 6.0	38.9 \pm 6.0	65.8	144.6*
PMA CL	68.2 \pm 22.6	83.0 \pm 10.7	64.5	250.2*
ZYM CL	41.4 \pm 12.4	84.0 \pm 8.4*	47.4	509.0*

¹Cell counts are given as millions/lavage.

CL values are millions of counts per second/10 minutes/ 1.63×10^6 alveolar macrophages.

*Significantly greater than control at $p < 0.05$ using a Student's T test.

dustrial dusts. Asymptomatic exposed subjects who were normal by clinical, radiologic and pulmonary function criteria nevertheless showed significant changes in cell populations and phagocytotic activity when compared with unexposed individuals. Much more extreme changes were observed in one subject suffering acute silicosis.

REFERENCES

1. Green, G.M.: Amberson Lecture: In Defense of the Lung. *Am. Rev. Respir. Dis.* 102:691-700 (1970).
2. Weiss, S.J., LoBuglio, A.F.: Biology of Disease: Phagocyte Generated Oxygen Metabolites and Cellular Injury. *Lab. Invest.* 47:5-18 (1982).
3. Heppleston, A.G.: Silicotic Fibrogenesis: A Concept of Pulmonary Fibrosis. *Ann. Occup. Hyg.* 26:449-462 (1982).
4. Castranova, V., Bowman, L., Reasor, M.J., Lewis, T., Tucker, J., Miles, P.R.: The Response of Rat Alveolar Macrophages to Chronic Inhalation of Coal Dust and/or Diesel Exhaust. *Environ. Res.* 36:405-419 (1985).
5. Hoidal, J.R., Fox, R.B., LeMarbe, P.A., Perri, R., Repine, J.E.: Altered Oxidative Metabolic Response In Vitro of Alveolar Macrophages from Asymptomatic Cigarette Smokers. *Am. Rev. Respir. Dis.* 123:85-89 (1981).
6. Greening, A.P., Lowrie, D.B.: Extracellular Release of Hydrogen Peroxide by Human Alveolar Macrophages: The Relationship to Cigarette Smoking and Lower Respiratory Tract Infections. *Clin. Sci.* 65:661-664 (1983).
7. Harris, J.O., Swenson, E.W. Johnson III, J.E.: Human Alveolar Macrophages: Comparison of Phagocytic Ability, Glucose Utilization, and Ultrastructure in Smokers and Nonsmokers. *J. Clin. Invest.* 49:2086-2096 (1970).
8. Hahon, N., Booth, J.A., Green, F., Lewis, T.R.: Influenza Virus Infection in Mice After Exposure to Coal Dust and Diesel Engine Emissions. *Environ. Res.* 37:44-60 (1985).
9. Castranova, V., Robinson, V.A., Tucker, J., Schwegler, D., Rose, D.A., DeLong, D.S., Frazer, D.G.: Time Course of Pulmonary Response to Inhalation of Cotton Dust in Guinea Pigs and Rats. In: *Proceedings of the Eleventh Cotton Dust Research Conference*. R.R. Jacobs and P.J. Wakelyn (eds), National Cotton Council, Memphis, TN, pp. 79-83 (1987).
10. Peterson, M.W., Nugent, K.M., Jolles, H., Monick, M., Hunninghake, G.W.: Uniformity of Bronchoalveolar Lavage in Patients with Pulmonary Sarcoidosis. *Am. Rev. Respir. Dis.* 137:79-84 (1988).
11. DeAraujo, A.T., Mendes, A.C., Monteiro, J., Duarte, G., Costa, M.F.E.: Bronchoalveolar Lavage and Silicosis Pathogenesis. *VIIth International Pneumoconioses Conference (Abs)* pp. 48 (1988).
12. Jones, G.S., Van Dyke, K., Castranova, V.: Purification of Human Granulocytes by Centrifugal Elutriation and Measurement of Transmembrane Potential. *J. Cell. Physiol.* 104:425-431 (1980).
13. Castranova, V., Bowman, L., Miles, P.R.: Ionic Content and Transmembrane Potential of Rat Alveolar Macrophages. *J. Cell. Physiol.* 101:471-480 (1979).
14. Banks, D.E., Morgan, J.E., Hammad, Y.Y.: Immunologic Features of the Bronchoalveolar Lavage Fluid of Rats with Silica-proteinosis. *VIIth International Pneumoconioses Conference (Abs)* pp. 35 (1988).
15. Goncalves, J.R., Correia, I., Raymundo, E., DeAraujo, A.T., Costa, M.F.E.: Inhaled Corticosteroids in the Treatment of Occupational Respiratory Diseases (ORD). *VIIth International Pneumoconioses Conference (Abs)* pp. 48 (1988).

EXPOSURES OF PRODUCTION EMPLOYEES TO AIRBORNE CONCENTRATIONS OF FIBROUS GLASS DURING THE MANUFACTURING PROCESS

C. W. AXTEN* • J. R. Bender* • P. F. Aubourg† • T. R. Jacobs† • M. R. Kalinowski† • E. J. Klotz†

*Owens-Corning Fiberglas Corp., Fiberglas Tower, T/11, Toledo, OH, 45659, USA

†Owens-Corning Fiberglas Corp., Technical Center, P.O. Box 415, Granville, OH, 43023, USA

INTRODUCTION

Airborne concentrations of fibrous glass can be evaluated either gravimetrically or by optical fiber counting methodologies. However, numerous studies^{1,2} have demonstrated that there is little correlation between gravimetric results and concentrations of fibrous glass present. For this reason, optical fiber counting methodologies rather than gravimetric analysis have become the methods of choice for fibrous glass analysis.

Prior to the publication of the Occupational Safety and Health Administration's Revised Asbestos Standard (29CFR 1910.1001) in June of 1986,³ the generally accepted procedure for the determination of airborne concentrations of asbestos, fibrous glass, and other man-made mineral fibers was the NIOSH P&CAM 239 method.⁴ However, with the promulgation of this Standard, a new methodology for the evaluation of airborne concentrations of fibrous materials was introduced, the NIOSH 7400 method.⁵

This method introduced a new sampling train for fiber collection (i.e. 25 mm cassette with 50mm extension cowl) as well as alternative methods for fiber counting (Rules "A" and "B"). Though similar in other respects to the NIOSH P&CAM 239 method, the new NIOSH 7400 method quickly began to receive increased attention from the industrial hygiene community as it was utilized to evaluate individuals' exposures to not only asbestos, but other man-made mineral fibers as well. Of particular concern was the notable adherence of fibers to the sampling cowl and the differing results obtained when fibers were counted via the "A" versus the "B" rules.⁶

With a considerable body of data on employees' exposures to fibrous glass obtained through use of the NIOSH P&CAM 239 method, it became imperative for Owens-Corning Fiberglas to evaluate the correlation between the two methods in terms of the sample results produced and to determine if the NIOSH 7400 method should be adopted for future exposure evaluations. Furthermore, since most of the information concerning use of the NIOSH 7400 method had been generated as a result of asbestos monitoring, it was felt that additional information could be gleaned through the use of the method to evaluate airborne concentrations of a man-made mineral fiber such as fibrous glass. Thus, the following study was designed and implemented.

MATERIALS AND METHODS

Seventy-five paired personal and area samples were collected in parallel on 0.8 micron pore size mixed cellulose ester filters mounted in 37 mm diameter polystyrene plastic cassettes with 16 mm non-electrically conductive extension cowl (i.e. NIOSH P&CAM 239 sampling method) or in 25 mm diameter polystyrene plastic cassettes with 50 mm electrically conductive extension cowl (i.e. NIOSH 7400 sampling method). During the initial phase of the study, additional samples were collected using 0.45 polycarbonate filters mounted in 37 mm diameter cassettes with 16mm extensions cowl for analysis by scanning electron microscopy. However, this approach was quickly discontinued due to the poor fiber retention (i.e. fibers were collected but were easily dislodged during transportation).

All samples were collected at a flow rate of two liters per minute (i.e. 2.0 l/m) using constant flow sampling pumps. The pumps were calibrated, with the filter and sampling train in line, before and after sampling using a precision rotameter calibrated against a primary standard (i.e. soap bubble meter for volumetric rate of air flow). Samples were collected at specific sites along plant manufacturing lines during the production of a variety of fibrous glass insulating products (e.g. batts, blankets, and loose fill). Samples were collected over significant portions of the work shift and are believed to be representative of full shift exposures.

All sample filters were mounted using the acetone/triacetin clearing method and analyzed via phase contrast optical microscopy (PCOM) at a magnification of 400X. Fiber counts for all sample filters were derived utilizing the procedures specified in both the NIOSH P&CAM 239 method as well as the NIOSH 7400 "A" method (i.e. all fibers >5 microns in length with aspect ratios equal to or greater than 3:1 were counted). Glass fibers were differentiated from other fibers by shape recognition using polarized light microscopy. Additionally, fiber length and diameter measurements were determined for a fraction of the samples.

To address fiber adherence to the sampling cowl, after filter removal, all cowl were rinsed with 25% isopropanol in distilled water. Rinse solutions were then filtered through 0.4 micron polycarbonate filters, and analyzed using the counting procedures described above.

After all sample results had been obtained, matched pair results were analyzed statistically to determine differences between the 37 and 25 mm diameter filters and corresponding cowl. Natural log transformed data were used to determine statistical difference at the 0.05 significance level.

RESULTS AND DISCUSSION

The sample results obtained from this study are indicated in Table I. The mean total fiber exposure and the lower and upper 95% confidence limits are shown for the forehearth, line, packer, bagger, rollup, repack cubed, and repack milled operators. The overall mean total fiber (both glass fiber and all other fiber) exposures of employees in OCF production facilities involved in the manufacture of fibrous glass insulation products were 0.024 f/cc for filters only and 0.03 f/cc for filters and cowls combined (NIOSH P&CAM 239 and 7400 methods combined). Additional analyses revealed that 70 to 75% were glass fibers and that 60% of the glass fibers were of a respirable size (i.e. diameters <3.5 microns, lengths of 5 to 250 microns, and length to diameter ratios of 3:1 or greater). Furthermore, these sample results were consistent irrespective of the type of product produced (i.e. faced vs. unfaced insulation) or the physical parameters of the product produced (i.e. R 30 vs. R19 or 24" width vs. 18" width).

Because a significant concentration of fibers were found adhering to the sidewalls of the cassettes (i.e. NIOSH P&CAM 239 Procedure) and to the sampling cowls (NIOSH 7400 Procedure), these fibers were also counted. Results are reported on Table I and Figure I as filter only and as filter and cowl combined. Figure I also includes results of samples collected in end-user applications. The data indicate that there was no statistically significant difference in sample results obtained from the NIOSH P&CAM 239 and 7400 methods when the "A" counting rules were used (see Figure 1). Furthermore, this result was consistent irrespective of the fiber type or size analyzed (i.e. total fiber, total glass fiber, or respirable glass fiber).

Statistical analysis also indicated that there was no difference between the total fiber results obtained from the NIOSH P&CAM 239 and 7400 methods using the "A" counting rules when the fibers on the filters and cowls were combined, Table II. Table II also includes results of samples collected in end-user applications. As indicated in Table II, the ratio, R, of (fibers deposited on cowls + fibers deposited on filters) / fibers deposited on filters, was 1.7 for the NIOSH P&CAM 239 method (i.e. 16 mm sampling cowl) and 1.5 for the NIOSH 7400 method. There was no statistical difference between these ratios.

Table I
Total Airborne Fiber Concentrations Obtained by Using the NIOSH P&CAM 239 and 7400 "A" Methods (Combined) Fibers per Cubic Centimeter

ITEM	ALL FIBERS							
	Filters				Filters and Cowls			
	# Samples	Exp. Value	95% LL	95% UL	# Samples	Exp. Value	95% LL	95% UL
FOREHEARTH	20	0.017	0.006	0.028	19	0.025	0.003	0.048
LINE	2	0.003	0.000	0.032	2	0.006	0.000	0.076
PACKER	30	0.028	0.017	0.040	29	0.036	0.017	0.066
BAGGER	8	0.023	0.012	0.033	7	0.030	0.002	0.067
ROLLUP	2	0.021	0.001	0.041	2	0.028	0.000	0.082
REPACK-CUBED	9	0.024	0.008	0.040	9	0.033	0.002	0.066
REPACK-MILLED	4	0.040	0.013	0.068	3	0.046	0.000	0.110

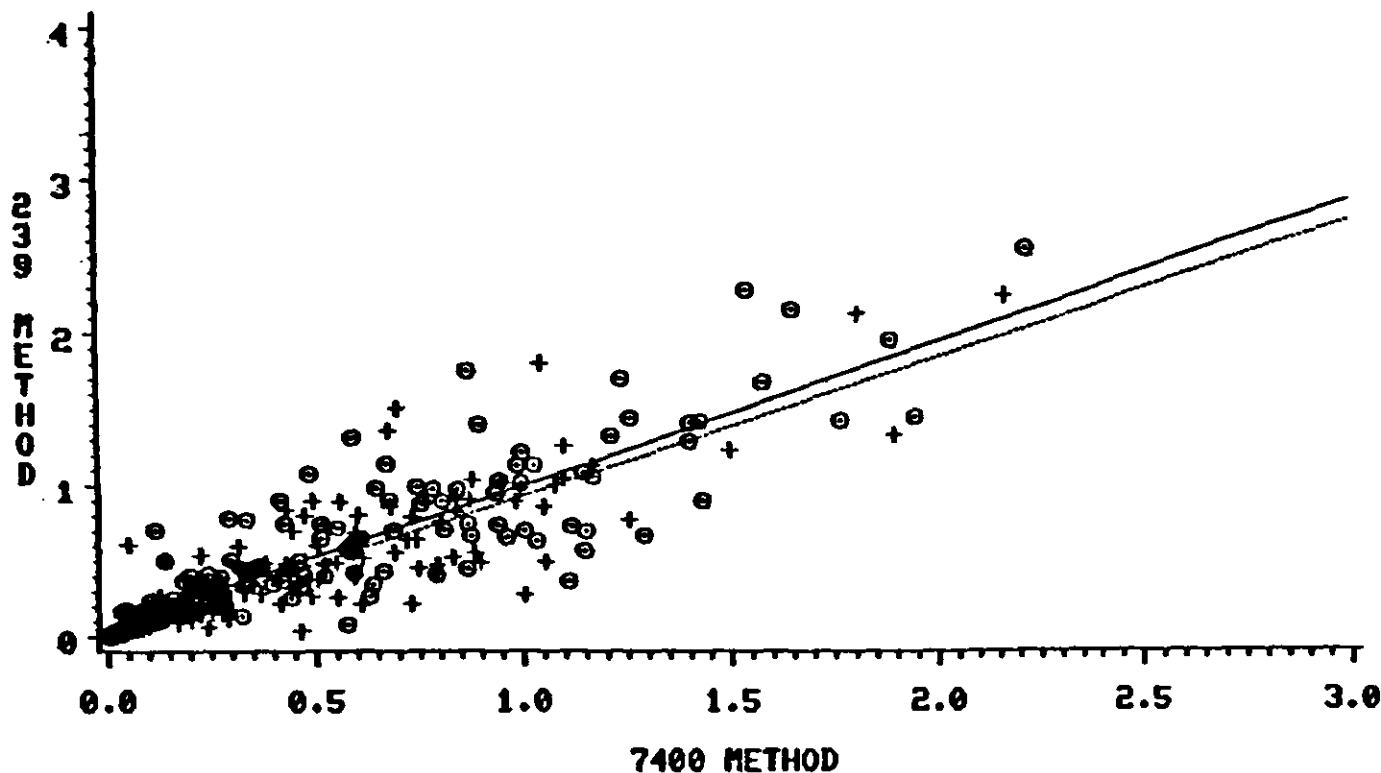

○=FILTER+COUL +=FILTER
 LINEAR REGRESSION LINES
 Figure 1. Total fibers per cc—random field counts.

Table II
 Ratio of (Fibers Deposited on Cowls + Fibers Deposited on Filters)
 Fibers Deposited on Filters for NIOSH P&CAM 239 and NIOSH 7400 Methods*

METHOD	# OF SAMPLES	AVERAGE	MEDIAN	STANDARD DEVIATION
239	162	1.7	1.5	0.90
7400A	160	1.5	1.4	0.52

NOTE: STATISTICALLY THE RATIOS FOR METHODS 239 AND 7400A ARE NOT DIFFERENT.

Significant fiber deposition on sampling cowls has been reported previously by Seixas et. al.⁶ Also, in commenting on this phenomenon, some investigators have suggested that a high ratio of fibers detected on sampling cowls versus fibers found on filters is merely an artifact produced by undercounting of fibers deposited on filters.⁷ This was not found to be the case, however, since the ratio, R, was consistently high for low as well as medium and high fiber counts.

CONCLUSIONS

The results obtained from our studies indicated that mean employee exposures to total fibers in Owens-Corning Fiberglas manufacturing facilities was 0.024 fibers/cc for filters only and 0.03 f/cc for filters and cowls combined. There was no statistically significant difference in the results obtained when the NIOSH P&CAM 239 and 7400 "A" methods were utilized. However, the study also demonstrated that there was a significant concentration of fibers deposited on the sampling cowls used for both methods which should conceivably be considered in determining the total level of exposures to fibrous glass.

REFERENCES

1. Konzen, J.L. "Results of Environmental Air-Sampling Studies Conducted in Owens-Corning Fiberglas Manufacturing Plants", pp. 115-120 in *Occupational Exposure to Fibrous Glass: A Symposium*, HEW Publication No. (NIOSH) 76-151, U.S. Department of Health, Education, and Welfare, Public Health Service, Center for Disease Control, National Institute for Occupational Safety and Health.
2. Esman, N., Corn, M. et. al. "Summary of Measurements of Employee Exposure to Airborne Dust and Fiber in Sixteen Facilities Producing Man-Made Mineral Fibers," *American Industrial Hygiene Association Journal*, 40:108-117.
3. Occupational Safety and Health Administration Standard—"Asbestos, Tremolite, Anthophyllite, and Actinolite," 29CFR 1910.1001, 51 *Federal Register*, June 20, 1986.
4. Analytical Method P&CAM 239 for "Asbestos Fibers in Air" in *NIOSH Manual of Analytical Methods—Second Edition*, DHEW (NIOSH) Publication No. 77-157, U.S. Department of Health Education and Welfare, Public Health Service, Center for Disease Control, National Institute for Occupational Safety and Health.
5. Analytical Method 7400 for "Fibers" in *NIOSH Manual of Analytical Methods—Third Edition*, DHHS (NIOSH) Publication No. 84-100, U.S. Department of Health and Human Services, Public Health Service, Center for Disease Control, National Institute for Occupational Safety and Health.
6. Sexias, N. et. al. "Bias Introduced by NIOSH Method 7400 Quantitative Fiber Exposure Assessment," *American Industrial Hygiene Association Journal*, 48:A242-243.
7. Keller, Richard, G., and Kestner, Chris, J. "Fiber Loss on Polycarbonate and Cellulose Ester Filters," Presentation at the American Industrial Hygiene Association Conference on May 23, 1985.

MEASUREMENT OF ROUNDED OPACITIES IN THE LUNG OF X-RAY IMAGES TOWARDS QUANTITATIVE DIAGNOSIS OF PNEUMOCONIOSIS

J. TORIWAKI* • X. Chen* • J. Hasegawa†

*Department of Information Engineering, Faculty of Engineering, Nagoya University Nagoya, Japan

†Department of Liberal Arts, Chukyo University, Toyota, Japan

INTRODUCTION

From a clinical and occupational health viewpoint, the classification of pneumoconiosis films is of primary importance. The category of profusion used for recording the severity of the pneumoconiosis is based on assessment of the concentration of opacities by comparison with standard pneumoconiosis films whose profusions are given by a four-point scale: categories 0, 1, 2 and 3.¹ However, in practical radiographical diagnosis, objective reading is very difficult even to the experienced readers. It is a fact that there is considerable variation in reading the same film, not only by different readers, but also by the same reader at different times. Therefore, it has been strongly desired to develop an automated measurement method for quantitative diagnosis of pneumoconiosis X-ray films.

In most of previous studies on automated classification of pneumoconiosis films, the approach is to examine some kinds of texture features measured from X-ray images by regarding the opacity distribution as a texture pattern.²⁻⁶ In such approach, however, it is difficult to avoid the influence of rib images and vessel shadows in chest X-ray images, and impossible to introduce necessary diagnosing experiences of medical experts into computer diagnosis process.

Since the advent of the more sophisticated digitization system in recent years which can provide high-resolution digital images, it has been possible to directly detect some kinds of very detailed objects in a chest X-ray film by computer, such as blood vessels, cancer lesions and pneumoconiosis small opacities. In this paper a new method for automated classification of pneumoconiosis chest X-ray films is presented, in which individual small rounded opacities are recognized, and the measured density of them is used as a classification feature. In experiments using ILO standard pneumoconiosis films, it is shown that density values of the small rounded opacities detected by this method are approximately proportional to the categories of profusion of pneumoconiosis. Moreover, the individual opacities detected by our system are compared with those by experienced radiologists to evaluate accuracy in opacity recognition. From the result, we see that not only the density values will be available as one of the effective features for computer diagnosis of pneumoconiosis, but also the detected small rounded opacities may be provided to the readers as reference data, and they are useful in training readers of pneumoconiosis films.

OUTLINE OF THE PROCEDURE

The processing procedure consists of the following three steps. First, the small rounded opacities in an input image are enhanced by a linear filter with a weight function designed based on a model of the small rounded opacity, then candidates of the opacities are obtained as a connected component pattern by thresholding the filtered image. Second, components due to shadows of ribs and vessels are removed by using a shape feature of a connected component to detect only objects suspected to be caused by the small rounded opacities. Third, the film is categorized according to the opacity density which is given by the ratio of the area or the number of the extracted opacities to the area of the lung region.

DETAILS OF THE PROCEDURE

Extraction of Opacity Candidates

Uniform weighted smoothing is used to suppress the random noise which is introduced in the processes of image generation and image digitization. Namely, it gives each point the average gray level of its neighboring points and the point itself.

The small rounded opacities are appearing or even overlapping with many kinds of other shadows such as ribs and blood vessels in a chest X-ray image. A linear differentiation filter is employed to enhance the opacities, in which a weight function is designed based on the local distribution of gray levels of the opacities. We see that the gray levels at a small rounded opacity in an input image are lower than those of the surrounding background. Each of the opacities is observed as a spot-like object with a circular border, whose gray level distribution inside the border is like a bowl shown in Figure 1(a), although its shape is likely to be more complicated. Therefore, a basic model of the weight function designed here is as shown in Figure 1(b), in which, every point on the circle with the radius $R1$ has the value 1, points in the central area with the radius $R2$ have negative values distributing as a bowl, and others are zero. The operation with this mask is a type of the 2nd order differentiation, and can enhance the bodies of the opacities against the background whose brightness may be variant according to the zone of the lung. Figure 1(c) shows a weight function practically used in the experiments.

The candidate regions of the small rounded opacities are ob-

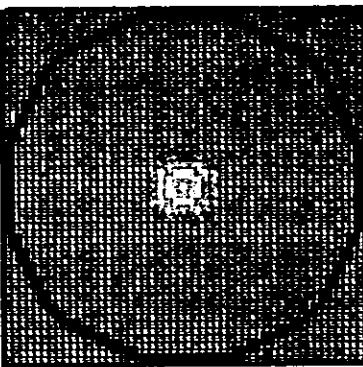
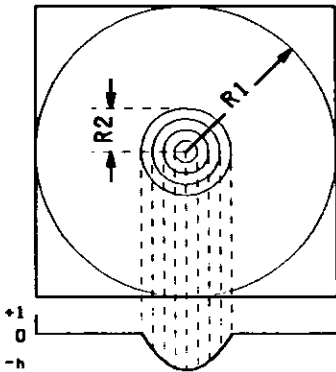
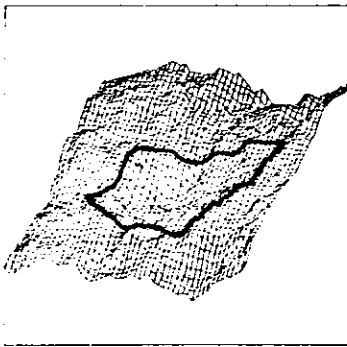

Figure 1. Small rounded opacity and weight function. (a) Local level distribution of an opacity and its neighborhood. (b) Weight function model. (c) Weight function used in the experiments.

tained by clipping the enhanced image with a pre-specified threshold. That is, values of pixels in the filtered image are changed into 0 if they are less than the threshold, then the remaining connected components are regarded as the candidate regions.

Recognition of Opacities

The candidate regions obtained above usually include many components caused by rib images and vessel shadows. Considering that the small rounded opacities should assumedly be isolated and be circular, and that the elongated regions may be generated by rib borders, the opacities can be extracted from the candidate regions by removing those components whose horizontal lengths are longer than a given value.

Furthermore, local maximum points of the enhanced image are detected in each of remaining regions to find the number and the location of the small rounded opacities. The operation is shown by the following equation:

where $\{f_{ij}\}$ and $\{g_{ij}\}$ are the input image (clipped enhanced image) and the output image (maximum point pattern), respectively, and N_{ij} is a local neighborhood region of the point (i,j) . When the above operation is done at a considerably smooth area in the enhanced image, the extracted maximum points may construct a connected component by themselves. Every such component is shrunk into a single point.

Density Calculation and Categorization

The 1980 ILO Classification states that classification of a radiograph for profusion of small opacities requires a mental process of integrating profusion over the affected zones.¹ However, in order to classify the pneumoconiosis films automatically, it is necessary to set up some objective measurements for evaluating the profusion of pneumoconiosis films. Here, a density of opacities is used as the measurement, which is defined as the ratio of the area or the number of the extracted opacities to the entire observed area in the lung region. The area of opacities is calculated by the total number of pixels of the opacities recognized from the candidate regions, while the number of opacities is specified as the number of the maximum points. The observed area is the area of processed lung region after removing the area of the components caused by rib borders. Finally, the chest X-rays are categorized according to the density values.

EXPERIMENTAL RESULTS AND DISCUSSION

Eleven chest X-ray images selected from a set of international standard pneumoconiosis radiographs which was accompanied with the 1980 ILO Classification were used in

the experiments. They include nine pneumoconiosis films containing three categories (1, 2 and 3) of each of three sizes (p, q, and r) and two films with category 0. Each film was digitized into 3300×3400 pixels with 12 bits of gray level. Some of them are shown in Figure 2.

Since profusion relates better than size to indices of exposure within any one occupational group,¹ a family of the linear filters matched to the size of small rounded opacities were employed in the enhancement step. The value of the parameters (R1, R2) in the enhancement filter are (2, 10), (3, 20) and (4, 25) for the size p, q, and r, respectively. An example of candidate regions extracted from a film (category 3, size r) is shown in Figure 3. The opacities recognized from it are shown in Figure 4, while the maximum points detected from its enhanced image are shown in Figure 5, where gray values of the enhanced image are drawn in terms of contour lines and the location of each maximum point is represented

by a circle with the radius proportional to the corresponding maximum value of the enhanced image. Figure 6 shows those maximum points superimposed by the circles on the corresponding original image. The opacity densities (vertical axis) calculated from each category of films (horizontal axis) are shown in Figure 7. From the results, it is known that the difference of the density between the category 3 and the category 2, or between the category 2 and the category 1 is relatively large, while it is difficult to distinguish the category 1 and category 0 decisively. A reason of this difficulty is that as the size (or the number) of the opacities become smaller, the extraction results will be more likely to be influenced by the blood vessel shadows.

In order to evaluate the accuracy of small rounded opacities detected by computer, they were compared with the opacities traced by experienced radiologists. The following procedure was employed in this tracing experiment. First an image to be



Figure 2. Examples of images used in the experiments cut from a set of international standard films by ILO. (a) (3/3,r/r). (b) (2/2,r/r). (c) (1/1,r/r). (d) normal.

traced is displayed on a high-resolution screen. Then, radiologists trace the small rounded opacities within the area specified by the same radiologists by using an interactive input device. On the screen, the traced opacities and the observed area are displayed by spots at the central position of them and a closed curve, respectively. Meanwhile, the location information of them is stored in the memory and used in the comparison. In Figure 8, each opacity traced by a radiologist is represented by a spot, and that extracted by computer is shown by a circle on the original image. Both results were

compared only in the inter-rib regions of the image. Summary of the result is given in Figure 9.



Figure 3. An example of extracted candidate regions of the small rounded pneumoconiosis opacities. (category 3, size r)

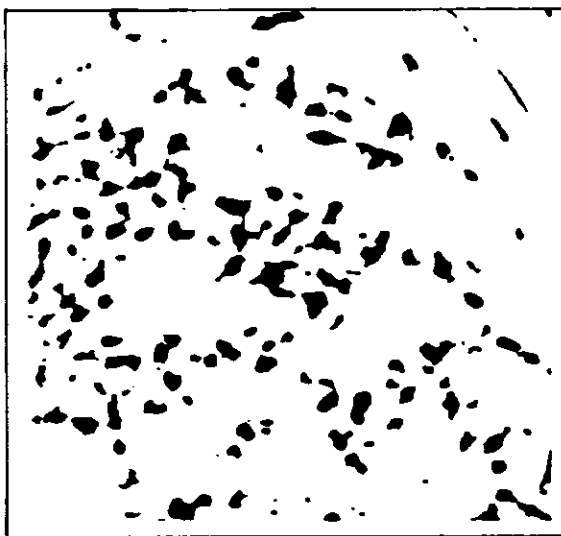

Figure 4. Extracted small rounded pneumoconiosis opacities.

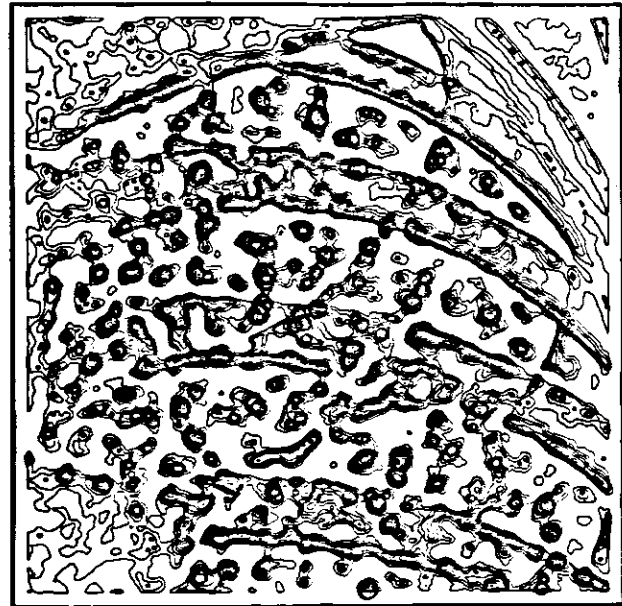

Figure 5. Maximum points of the enhanced image extracted from each of small rounded opacities.



Figure 6. Extracted maximum points superimposed on original image.

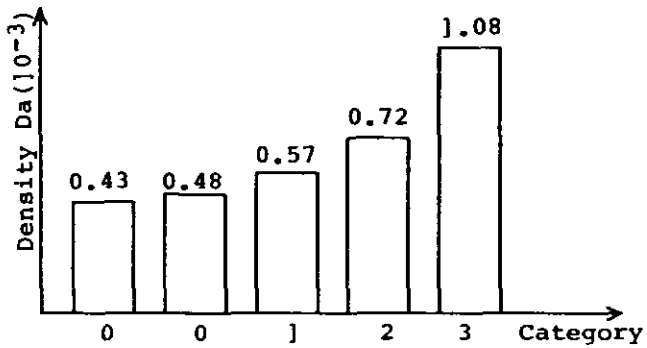
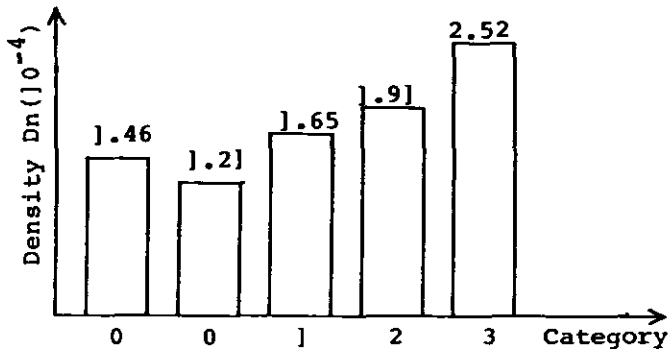

Figure 7. Density of opacities calculated from ILO standard films. (a) Area density. (b) Number density. (size r)

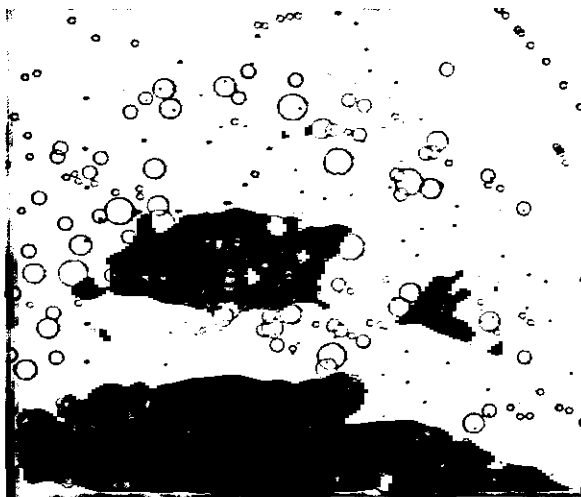

Figure 8. An example of small rounded opacities extracted by an experienced radiologist, and those by computer in the same original image. (category r, size r)

The extraction procedure of small rounded opacities described in this paper was also applied to the pneumoconiosis images obtained by the Fuji computed radiography system. Figure 10 shows both results by computer and radiologists on the original image, and the notation is the same as that used in Figure 8. The results showed that the procedure was also effective to computed radiography image.

CONCLUSION

A method to detect pneumoconiosis small rounded opacities and to evaluate their densities was proposed for automatic categorization of the profusion. It was shown by experiments using ILO standard pneumoconiosis films and the computed

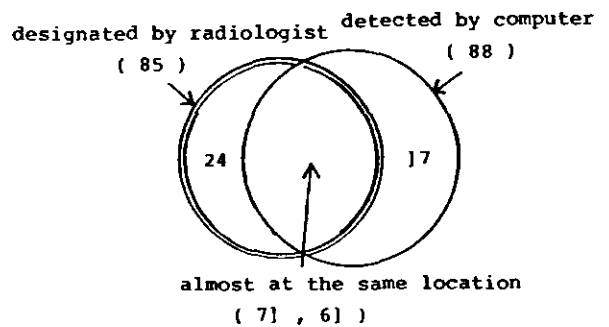

Figure 9. Result of comparison between the opacities extracted by experienced radiologist, and those by computer (Figure 8).



Figure 10. An example of small rounded opacities extracted by experienced radiologists, and those by computer on a film obtained by the Fuji computed radiography system. (category 3, size q)

radiography images that the opacity density measured by the proposed procedure was approximately proportional to the categories of profusion of pneumoconiosis. To improve the system performance, it is necessary to develop a procedure to recognize blood vessel shadows more correctly.

REFERENCES

1. International Labour Office: *Guideline for the Use of ILO International Classification of Radiographs of Pneumoconiosis*. Revised Edition (1980).
2. Kruger, R.P., Thompson, W.B. and Turner, A.F.: Computer Diagnosis of Pneumoconiosis. *IEEE Trans. on Syst., Man, and Cybern.* SMC-4:40-49 (1974).
3. Hall, E.L., Crawford, W.O. and Roberts, F.E.: Computer Classification of Pneumoconiosis from Radiographs of Coal Workers. *IEEE Trans. on Biomed. Eng.* BME-22:618-527 (1975).
4. Jagoe, J.R. and Paton, K.A.: Measurement of Pneumoconiosis by Computer. *IEEE Trans. on Comput.* C-25:95-97 (1976).
5. Stark, H. and Lee, D.: An Optical Digital Approach to Coal Workers' Pneumoconiosis. *IEEE Trans. on Syst. Man. and Cybern.* SMC-6:788-793 (1976).
6. Kobatake, R. and Takatani, O.: Computer Diagnosis of Pneumoconiosis from Radiographs. *Jap. J. of Med. Electro. and Biolog. Eng.* 20:23-29 (1982). (in Japanese)
7. Chen, X. Hasegawa, J. and Toriwaki, J.: Quantitative Diagnosis of Pneumoconiosis Based on Recognition of Small Rounded Opacities in Chest Radiographs. *Rep. of Technical Group on Pattern Recognition and Understanding, IEICE, Japan, PRU87-9:25-32* (1987). (in Japanese)

This work was supported in part by Grant-in-Aid for Scientific Research (No. 62460125), Ministry of Education of Japan Grant-in-Aid for Cancer Research (62-42), Ministry of Health and Welfare of Japan and the Committee for Quantitative X-Ray Diagnosis of Pneumoconiosis.

ACKNOWLEDGEMENT: The authors are grateful to Doctor Y. Hosoda of Radiation Effects Research Foundation, and members of the Committee for Quantitative X-Ray Diagnosis of Pneumoconiosis for their cooperation and advice.

COST EFFECTIVENESS OF PRE-EMPLOYMENT PULMONARY FUNCTION SCREENING IN NEW HIRE FOR ELECTRONIC ASSEMBLY LINE WORK

R. THAN MYINT,* M.D.,D.I.H. • Shoib Myint,† B.S.

*Assistant Clinical Professor Occupational Medicine, Department of Comprehensive Medicine
University of South Florida, Tampa, Florida
Consultant, Occupational Medicine and Industrial Toxicology
Occupational Medicine and Industrial Health Services, Tampa, Florida
†Post-Graduate Studies, Columbia University, New York, New York, USA

Approximately 179,400 production workers were employed in the United States in facilities that manufacture electronic components and accessories. (SIC 3672-3678).¹

In the electronic component manufacturing industry, a wide variety of processed material are used. Mixed chemicals exposure and the by-products and synergistic actions effect biologically. Simultaneous exposure to more than one toxic agent such as III Trichloroethane, Acetone, Methylene ketone, Freon, Methylene Chloride, Lead, Flux, Tin, Thalate Esters, Epoxy Resins, Alcohol. These chemicals were used by assembly workers in different departments, like soldering, rework, touch up, plating, conforma coating, potting.

Not many in literature, but few authors, investigators postulate that the Small Airway Diseases (SAD) represents significant airway obstruction in peripheral bronchioles and as such may present an early manifestation of chronic obstructive lung disease, when it may be amenable to treatment.

Myint and Myint² postulated that the early findings of FEF₂₅₋₇₅ impairment with mixed chemicals exposures in electronic industries.

Wright and Colleagues⁴ stated that inflammatory process in small airway lining thus reduction in FEF₂₅₋₇₅ volumes.

In this paper, the author discusses the findings of 275 new applicants' Pulmonary Function Tests (PFT) who were hired for electronic assembly work. Morbidity data on small airway diseases, obstructive lung diseases were analyzed. In addition, the results of visual acuity examination as to perform government contract, applicant must meet government visual standard in near, distant, depth, color and field of vision.

MATERIAL AND METHOD

During the early part of 1987, pre-employment physical examinations were done by certified occupational health physician. Besides hands-on physical, pulmonary function tests were performed by qualified and trained technician and used Jones Pulmonar II in standing position with good effort and cooperation. The standard criteria of the American Thoracic Society 1979 was used. Results obtained were FVC, FEV₁, FEF₂₅₋₇₅ and FEV₁/FVC ratio. Predicted values of Knudson

were preferred. Due consideration was given to ethnic factor calculation. Seventy-five percent of the predicted value readings was taken as the normal range. The values were corrected to BTPS. The best of at least three spirograms was chosen.

The vision test was performed by Titmus vision, color test was performed by Ishihara plate, field of vision test.

RESULTS

Among 275 applicants, the majority of them were between the age group of 19-39. Non-cigarette smokers were also majority as shown in Table I, 61.81% non-smokers and 38.18% were smokers. Also Table I analyzed number of smokers and non-smokers in each group.

Table II shows abnormal pulmonary function performances: Among 170 of non-smokers 18% had small airway impairment; this could probably be from previous impairment.

Job exposure to mixed chemicals, smokers have higher incident of small airway impairment 33.33%. There were 14 mild and moderate chronic obstructive lung diseases and eight of them were disqualified for assembly work.

Figure 1 illustrates the normal pulmonary function tests (PFT). Higher numbers were observed in younger age group 19-39. As the age gets older with longer exposure history PFT abnormal findings were characteristic.

As the government contract, minimum visual acuity is 20/40 with no defect in color, depth and field of vision using the Titmus Machine. Interestingly, many applicants were not aware of their defective vision. The abnormal vision test was done with and without glasses. Author is concerned about chronic toxic solvent exposure effecting color and field of vision with toxic chemicals which have been reported in United States and European literature. Table III shows the younger age group as having high prevalence of defective distant vision, where other age group has both near and distant vision defect.

DISCUSSION

There is scarcity in literature about cost-effectiveness of Pre-employment Pulmonary Function Tests (PFT).

Table I
Pulmonary Function Testing in Different Age Groups in Pre-employment Screening of Electronic Assembly Workers, Tampa, Florida

AGE GROUP	NON CIGARETTE SMOKERS		CIGARETTE SMOKERS	
19 - 29 91	55	60%	36	39.56%
30 - 39 98	68	69.38%	30	30.61%
40 - 49 54	25	46.38%	29	53.70%
50+ 32	22	68.75%	10	31.25%

Table II
Prevalent of Abnormal Pulmonary Function Performances in Cigarette Smokers and Non Smokers in Pre-employment Screening of Electronic Assembly Workers, Tampa, Florida

AGE GROUP	FEF25-75		FVC		FEV1/FVC RATIO		PREVIOUS HISTORY OF EXPOSURE TO MIXED CHEMICAL SOLVENTS & SPRAY PAINTS
NON SMOKERS 170 61.81%	32	18%	6	3.5%	4	2.3%	TOTAL 70 41.17%
SMOKERS 105 38.18%	35	33.33%	8	7.61%	14	13.33%	
TOTAL 275	67	24.36%	14	5.09%	18	6.54%	

As mentioned in literature, small airway disease is an early indication of mixed chemical exposure; the pre-employment PFT screening is constantly worth considering.

At present litigation scenario many legal battles have been lost because claimants suffer from hypersensitivity pneumonitis due to chemical exposure. Also, claimant has been awarded because of small airway impairment because of working on assembly line in electronic industry.

High stake workers compensation expenses have been paid on Permanent Partial Disability due to Chemical Induced Lung Diseases.

Recent study indicated small airway is a sensitive parameter in early detection of expiratory airflow obstruction. Potential high risk employees could be considered for early treatment and job placement.

It is a good documentation of previous existing condition of PFT abnormal findings. As we commonly see in workers compensation scenario, "I never had my lung test abnormal, I have worked with these chemicals and nobody told me about it." The disadvantage factor is under Workers Compensation Law aggravation from present job exposure become compensable and the present employer is liable.

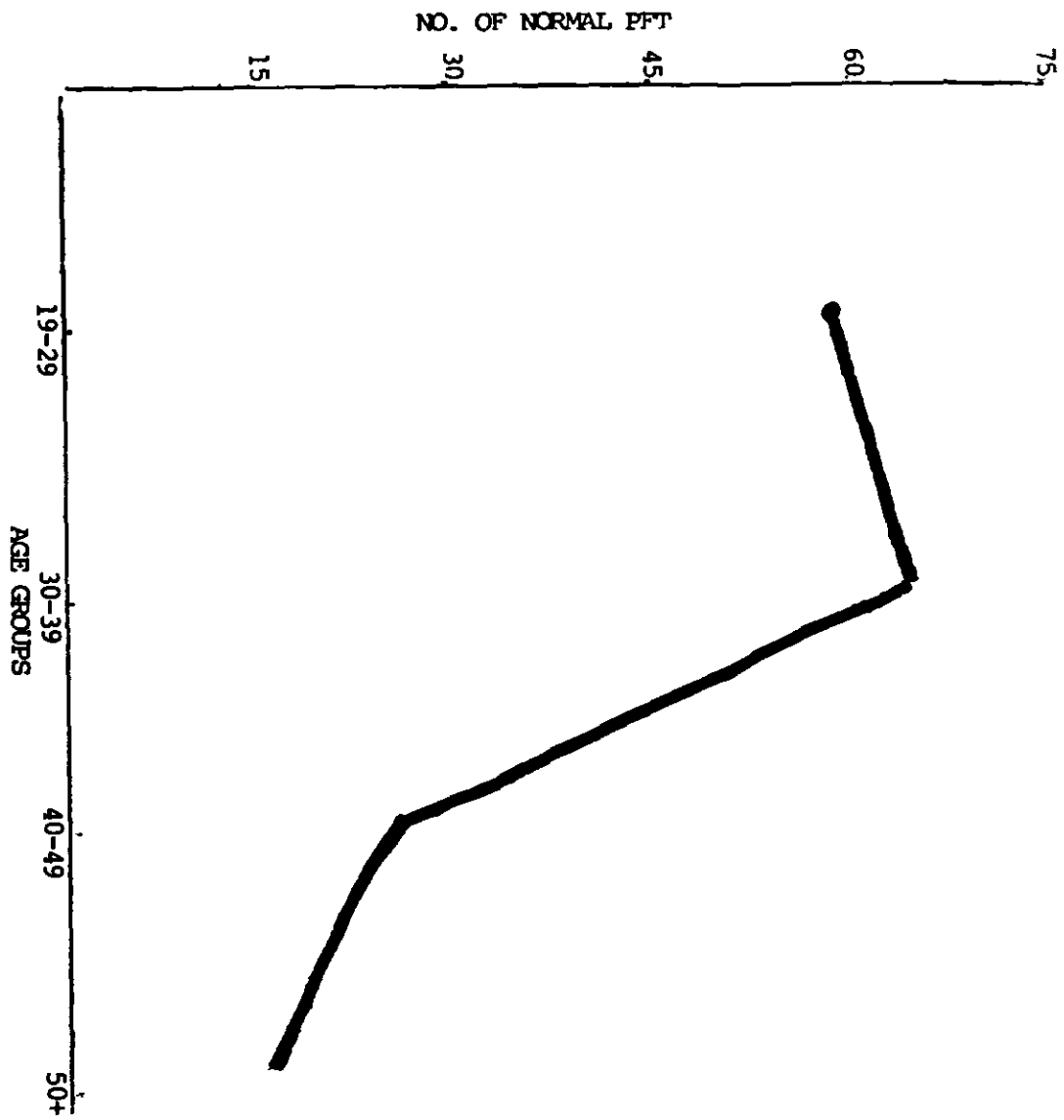

Figure 1. Normal PFT decline with age.

Table III
Visual Defects in 275 Applicants' Physical for Electronic Assembly Plants, Tampa, Florida

AGE	TIMMUS VISION TESTS - ABNORMAL		ISHIHARA COLOR VISION	FIELD OF VISION
	NEAR	DISTANT		
19 - 29 91	8	20	1	0
30 - 39 98	16	21	2	3
40 - 49 54	22	21	1	1
50+ 36	17	15	1	3

However, early sign of sensitivity, early sign of bronchitis with baseline PFT value from pre-employment is surely valuable in decisionmaking for the betterment of employer, employee and workers compensation carrier.

Many adverse effects from chemical exposure and cigarette smoking have been reported. If baseline PFT results are available, further education to employee and proper job placement could prevent many problems in the future.

This study is a signal parameter involved therefore future epidemiologic studies can be undertaken with a large population.

REFERENCES

1. Cosio, M., Ghezzi, H., Hogg, J., et al: "The Relationship Between Structural Changes In Small Airway and Pulmonary Function Tests," *N. Engl. J. Med.* 298:1277-81 (1978).
2. Myint, R.T., Myint, S., "Early Small Airway Impairment In Electronic Assembly Workers Exposed To Mixed Chemicals," *Am. Coll. Tox.* 5:6,607 (1986)
3. Wegman, D.H., Peters, J.M., Boundy, M.G., Smith, T.J., "Evaluation Of Respiratory Effects In Miners and Millers Exposed To Talc Free Of Asbestos and Silica," *Brit. J I M* 39:233-8 (1982)
4. Wright, J.L., Lawson, L.M., Pare, P.D., Kennedy, S., Wiggs, B., Hogg, J.C., "The Detection Of Small Airway Disease," *Am. Rev. Respir. Dis.* 129:989-999 (1984).

ACKNOWLEDGEMENT: Both authors express their appreciation to Mrs. Dixie Martinez for her assistance in the preparation of the manuscript.

UTILITY OF QUANTITATED SPUTUM CYTOLOGY TO DETECT THE EFFECTS OF EXPOSURE IN SMOKERS AND NONSMOKERS

TINA J. ROBY,* M.S., CT (ASCP) (IAC) • Gary E. Swan,† Ph.D.
• G. Berry Schumann,‡ M.D. • Louis C. Enkema, Jr.,* M.D.

*CytoSciences, Inc. 1601 Saratoga/Sunnyvale Rd. Cupertino, CA 95014, USA

†Health Sciences Program SRI International Menlo Park, CA, USA

‡CytoPathology Division University of Utah Health Services Center Salt Lake City, UT, USA

INTRODUCTION

The primary goal of health monitoring in the workplace is to detect early environmentally induced damage to the body and thus prevent disease. The largest problem in monitoring the pulmonary health of any individual when attempting to prevent the development of lung cancer or obstructive lung disease is the complicating effects of cigarette smoking. Researchers have provided insight into the additive or synergistic effect of tobacco smoke with certain environmental and occupational pollutants, such as asbestos, etc.⁹ Although risk ratios for the development of lung cancer due to this synergism have been derived, a standardized methodology to discriminate the toxic effect of the exposure from that of cigarette smoking has yet to be developed.

Traditional testing methodologies have focused on the detection of advanced or end stage disease. Chest radiography is unable to detect the early developmental stages of lung cancer. With rare exception, bronchoscopic and cytologic techniques have focused on the presence or absence of malignancy. Pulmonary function tests become definitively abnormal only after widespread structural damage in the bronchial airways. The limitations of these current approaches are obvious. Too often a lesion, once detected, is largely irreversible and frequently carries with it a poor prognosis.

A quantitative cytologic method has been developed to analyze material from the lungs utilizing sputum analysis. This method provides useful information about early airway damage, hopefully while simple intervention and subsequent reversibility of the damage may still be possible. Our goal is also to provide a test which is inexpensive, non-invasive, objective, reliable, sensitive and accurate to individually evaluate and monitor cellular damage due to inhaled toxins.

Several researchers have provided a rationale for a more detailed and comprehensive study of cytologic components that have been associated with bronchial irritation. Mylius observed that pulmonary macrophages increase in individuals exposed to industrial air pollution.⁴ The results from Madison's, et al. study on coke oven workers suggested that early states which precede lung cancer and bronchitis may share common features. Their research found that reactive bronchial epithelial cells and metaplasia were potent

predictors of an abnormal FEV₁/FVC.³ Earlier work by Frost suggested that individuals in high risk industries showed higher incidence of atypical (at least mild dysplasia) cytologic findings in sputa than did individuals in low risk industries. Frost also suggested that the key defense mechanisms of respiratory macrophages, the mucociliary blanket and tracheobronchial epithelium could be effectively monitored.²

The objective of this pilot study was to determine whether the effects of occupational exposure are observable in both nonsmokers and smokers and whether these effects could be discriminated from the effects of cigarette smoking. We also studied whether there was a measurable additive or synergistic effect in the group of smokers who also had exposure to occupational toxins.

MATERIALS AND METHODS

Four groups (smokers, exposed and nonexposed; nonsmokers, exposed and nonexposed) of approximately 25 individuals who matched the following criteria were randomly selected from a pool of over 1800 subjects: males of approximately the same age with adequate and satisfactory sputum results; two occupational groups with similar self-reported exposures (asbestos, arsenic, beryllium, inhalants by urban firefighters); and two cigarette smoking groups with similar smoking histories. The selection process yielded 25 nonexposed/nonsmokers, 21 nonexposed/smokers, 24 exposed/nonsmokers and 25 exposed/smokers. We were unable to determine the length, duration and dose of the occupational exposure.

A three-day pooled, spontaneously produced sputum specimen was collected into 23 mls. of Saccomanno's fixative (50% ethanol, 2% polyethylene glycol and rifampin). The samples were processed using the blending methodology according to the Saccomanno technique and stained with a modified Papanicolaou stain.

The microscopic examination of the slides consisted of counting the following eight entities: alveolar macrophages, pigmented macrophages, neutrophils, mucus, mucous spirals, columnar, metaplastic and dysplasia cells. The counts were expressed as a number or amount of that component per slide or 40X field. The amount per slide or 40X field

was then translated via an established algorithm into an ordinal scale with a range of 0 through 10. Zero represented no evidence of that particular entity being present, while 10 represented the maximum amount of any entity being present on the slide.

Two components, although quantitative, were more descriptive in nature. Pigmented macrophages were assessed based on density of coloration and amount and size of particulate matter being present. Mucus was assessed by the thickness, character and pattern. Dysplasia (atypical metaplasia) was assessed using well described morphological parameters.

Although not part of the main analysis, benign bronchial hyperplasia (BH), reactive bronchial lining cells (RBLC), and elevated levels of eosinophils (>10% of the white cell population) were noted if present on each case.

STATISTICAL METHODS

The data array for each cytologic component in this study was viewed as constituting a 2×2 analysis of variance with smoking (yes or no) and exposure (yes or no) as the main effects. Because a goal of the study was to identify significant smoker \times exposure interactions, an interaction term was modeled in the analysis of variance as well. The general linear model procedure (PROC GLM, SAS® Institute) was used to identify significant overall effects; main effects for smoking and exposure, and the interaction effect were tested against Type III sums of squares.⁷ A separate general linear model was constructed and tested for each of the eight cytologic components. Because this study was exploratory in nature and limited in sample size, our approach was to analyze each component separately.

For those models demonstrating an overall significant F test, subsequent tests comparing mean scores of nonexposed to exposed subjects, within smokers and nonsmokers were conducted. Tukey's (1952, 1953) procedure was used to control the maximum experimental error rate for multiple comparisons.⁶ Differences between means for each component were compared against the minimum significant difference computed by the Tukey procedure at an overall $\alpha=0.05$ level.

RESULTS

Table I shows the age and smoking history for each of the four groups. All groups were equivalent with respect to both age and smoking history. Table II lists the nature of the occupational exposures for the exposed nonsmoking group and the exposed smoking group. The range of exposures in each group was similar.

Overall Models

Tables III and IV show, respectively, the mean values and standard deviations for each component in each group, and the F values resulting from the analyses of variance. Table IV reveals significant overall models for all components except for dysplasia. Corresponding R² values indicate that these models account for between 19% (spirals) and 53% (pigmented macrophages) of the variability in the cytologic components.

Smoking Main Effects

Present smokers had consistently and significantly higher mean levels on seven out of the eight components (dysplasia being the exception) compared to nonsmokers.

Exposure Main Effects

Exposure status was associated with smaller differences but there were significant effects for pigmented macrophages, neutrophils, mucus, and columnar cells. Individuals reporting exposure had the following mean values compared to those reporting nonexposure: pigmented macrophages (5.6 vs. 5.0) neutrophils (5.7 vs. 4.9), mucus (4.7 vs. 3.7) and columnar cells (4.6 vs. 3.2).

Smoking ⁴ Exposure Interactions

Significant interactions emerged for spirals and columnar cells. Marginally significant associations were observed for mucus and metaplasia. Subsequent tests reveal that for three of the four components, the significant interaction term is due entirely to the relationship of exposure to the various components in nonsmokers. Compared to nonexposed nonsmokers, exposed nonsmokers had significantly higher levels for mucus ($t=2.65$, 47df, $p<0.05$), columnar cells

Table I
Age and Smoking History of Sample Populations

	Average Age	s.d.	PackYears	s.d.
NonSmoker/No Exposure	42.5	15.8	--	--
Smoker/No Exposure	41.6	10.2	36.1	15.8
NonSmoker/Exposed	40.7	12.3	--	--
Smoker/Exposed	43.3	9.2	36.0	23.5

s.d. - standard deviation

Table II
Nature of Occupational Exposures

	Nonsmokers (n=21)	Smokers (n=25)
Asbestos	14	11
Arsenic	2	1
Beryllium	2	3
Coal	2	0
CO ₂	0	1
Diesel Fuel	0	1
Dust (logging)	1	1
Fiberglass	0	1
Insulation	0	1
Smoke (chemical fires)	2	2
Smoke (other fires)	1	0
Welding	0	3

($t=3.69$, 34 df, $p<0.05$), and metaplasia ($t=2.35$, 47 df, $p<0.05$). For the fourth component, spirals, there was the possibility of a crossover interaction which, upon subsequent testing, did not yield significant differences for exposure either within smokers or nonsmokers. While a significant interaction term did not emerge in the analysis of variance for neutrophils, we did observe exposed nonsmokers to have higher mean levels than did nonexposed nonsmokers ($t=2.83$, 47 df, $p<0.05$)

DISCUSSION

We have shown significant cytologic differences between nonsmokers and smokers.⁸ These results also indicate that quantitative sputum cytology is capable of detecting measurable differences in subpopulations of nonsmokers with and without exposure to occupational irritants. Of particular note was the elevation of neutrophils, mucus, columnar and metaplastic cells in the exposed nonsmoker group. These data provide evidence that early indications of bronchial irritation due to inhalation of environmental toxins can be monitored. The prognostic ability of these changes to determine the risk of lung disease with continued exposure needs further exploration.

Although there were not statistically significant differences among the smokers with and without exposures in our study, there were more cases showing elevated levels of eosinophils and bronchial hyperplasia in the exposed smoker group (20% and 12%, respectively), as compared to the nonexposed smoker group (8% and 0%, respectively) Table V shows the results of these additional cytologic observations across the four groups. The nonsmoker/exposed group had higher levels of all three entities than any other group (eosinophils—25%; RBL—12.5%; and BBH—12.5%). One explanation of these elevations might be the presence of an allergic or asthmatic response to the environmental toxin.

Our results indicate that there is no significant synergistic effect in the presence of both cigarette smoking and exposure to an occupational irritant. Although Mylius found that the number of pulmonary macrophages increased with exposure to industrial air pollution and that there appeared to be a synergistic effect of occupational pollution and smoking, our data are not necessarily contradictory.⁴ Explanations may be that: a) in the presence of cigarette smoking, there is a ceiling effect resulting from the tobacco smoke which may mask any effect from the exposure for some period of time; b) small sample size; or c) the fact that the exposure variable relied upon self-report. Another important factor to be considered is that the exact nature, length of time of the exposure, or amount of exposure was not fully known in our study. A larger, more controlled study needs to be initiated which would present a clearer and more objective analysis of this phenomena.

Industry, workers, their unions, the insurance industry, the courts, and the medical profession have concern about the identification and nature of respiratory hazards in industry; progress in early diagnosis, prevention and medical intervention of occupationally induced respiratory disease; understanding of the pathogenesis of respiratory disorders and progress in worker protection from respiratory hazards. In most settings and in many individuals, it is difficult to sort out to what extent cigarette smoking has contributed to respiratory disease as compared to the effect of occupational toxins. Traditional methodologies to measure and/or separate the effects of cigarette smoke have shown disappointing and inconsistent results. The effects of industrial toxins to the nonsmoking individual is less difficult to assess since the complicating effects of tobacco smoke are not present. There is however, difficulty in detecting the earliest stages of disease with current testing methodologies which make sense and are cost effective in the workplace.

Table III
Means and Standard Deviations of Cytologic Components

	NonSmoker No Exposure (n=25)	NonSmoker Exposure (n=24)	NonSmoker Exposure (n=21)	Smoker No Exposure (n=25)	Smoker Exposure
Macrophages s.d.	4.4 (1.2)		4.9 (1.5)	6.3 (1.3)	6.6 (1.2)
Pigmented Macrophages s.d.	4.0 (0.8)		4.4 (1.3)	6.2 (1.0)	6.7 (1.3)
Neutrophils s.d.	4.1 (1.2)		5.3 (1.7)	5.9 (1.3)	6.0 (1.8)
Mucus s.d.	2.4 (1.8)		3.8 (2.0)	5.4 (1.4)	5.5 (1.6)
Mucous Spirals s.d.	0.0 (0.0)		0.2 (0.5)	1.6 (2.5)	0.7 (1.1)
Columnar Cells s.d.	1.1 (1.7)		4.0 (3.4)	5.5 (1.9)	5.1 (2.5)
Metaplastic Cells s.d.	1.3 (1.8)		2.8 (2.4)	4.7 (2.6)	4.3 (2.6)
Dysplastic Cells s.d.	0.2 (0.8)		0.0 (0.0)	0.4 (1.1)	0.3 (1.1)

Although sputum cytology has become a medically accepted diagnostic procedure for lung cancer, it has not been accepted as a screening methodology for high risk individuals since the actual incidence of lung cancer is low and the prognosis is not believed to be influenced by screening.⁵ The picture would change if newer diagnostic techniques allow for the identification of premalignant changes in the bronchial airways. Treatment modalities such as vitamin (beta carotene) therapy along with smoking cessation are being tested with the hope of eradicating early disease, thus changing the natural course of lung cancer.

Recently Frost stated that sputum cytology may have its greatest value to both the worker and employer in its potential to monitor individual responses to harmful exposures before the development of disease.¹ Despite the results in our smoking subjects, there is clear indication that quantitative sputum cytology provides a noninvasive tool which is capable of showing change in the bronchial airways of individuals in varying environments. Our preliminary results

suggest that this testing methodology may be valuable in monitoring individual cellular response to toxic occupational exposure before the onset of serious lung disease. Clearly, further study is required to assess the importance of these preliminary findings.

REFERENCES

1. Frost, J.K. et al: Sputum Cytopathology: Use and Potential in Monitoring the Workplace Environment by Screening for Biological Effects of Exposure. *Journal of Occupational Medicine*. 28:692-703 (1986).
2. Frost, J.K. et al: Pulmonary Cytologic Alterations in Toxic Environmental Inhalation: *Human Pathology* 1:521-536 (1973).
3. Madison, R., Afifi, A.A., Mittman, C.: Respiratory Impairment in Coke Oven Workers: Relationship to Work Exposure and Bronchial Inflammation Detected by Sputum Cytology. *J. Chron. Dis.* 37:167-176 (1984).
4. Mylius, E.A., Gullvag, B.: Alveolar Macrophage Count as an Indicator of Lung Reaction to Industrial Air Pollution. *Acta Cytologica* 30:157-162 (1986).
5. National Cancer Institute (NCI): *Atlas of Early Lung Cancer*. Igaku-Shoin, New York (1983).

Table IV
F-Statistics to Test the Effect of Smoking, Exposure and
Their Interaction on Different Cytologic Component Ratings

Cytologic Component

Effect	Macro- phages	Pigmented Macro- phages	Neutro- phils	Mucus	Mucous Spirals	Columnar Cells	Meta- plastic Cells	Dys- plastic Cells
Smoking	48.2***a	96.9***	16.9***	45.4***	15.7***	30.2***	25.2***	2.5
Exposure	2.0	3.4*	4.7**	5.0**	2.1	5.8**	1.2	0.8
Smoking X Exposure	0.2	0.1	2.5	3.4*	4.2**	10.3***	3.3*	0.0
Overall Model								
F	17.20***	34.30***	8.30***	18.40***	6.90***	15.70***	10.00***	1.00
R2	0.36	0.53	0.21	0.38	0.19	0.34	0.25	0.03

a Numeric value is the F-value computed under the general linear model. F tests for individual effects are tested with 1 and 91 df; those for the overall model are tested with 3 and 91 df.

* p<0.10
 ** p<0.05
 *** p<0.01

Table V
Cytologic Observation of Eosinophils, Reactive Bronchial
Lining Cells and Benign Bronchial Hyperplasia

	Nonsmoker/ No Exposure (n=25)		Nonsmoker/ Exposure (n=24)		Smoker/ No Exposure (n=21)		Smoker/ Exposure (n=25)	
	Number	%	Number	%	Number	%	Number	%
Eosinophils*	3	12.0	6	25.0	2	9.5	5	20.0
Reactive Bronchial Lining Cells	0	—	3	12.5	0	—	0	—
Benign Bronchial Hyperplasia	0	—	3	12.5	0	—	3	12.0

*Eosinophils were considered elevated at >10% of the white cell population.

6. SAS® System for Linear Models, pp. 55, 61. SAS Institute, Inc. Cary, NC (1986).
 7. SAS® User's Guide: Statistics, 5th Edition. SAS Institute, Inc. Cary, NC (1985).
 8. Schumann, G.B., Swan, G., Roby, T., Sorensen, K., Enkema, L.C., Jr.: Unpublished Data. University of Utah Health Sciences Center, Salt Lake City, UT (1988).

9. Selikoff, I.J., Hammond, E.C., Churg, J.: Asbestos Exposure, Smoking and Neoplasia. JAMA 204:104-110 (1968).

ACKNOWLEDGEMENTS: The authors thank Christine Sutcliffe for the manuscript preparation and Robert Curtis, Patricia Jeys and Gayle Hubbard for their assistance in the production and arrangement of the graphics used for presentation.

EFFECT OF COAL DUST ON MUCIN PRODUCTION BY THE RAT TRACHEA

V. P. BHAVANANDAN

Department of Biological Chemistry, The M.S. Hershey Medical Center
The Pennsylvania State University, Hershey, PA 17033

ABSTRACT

The mucus secreted in the respiratory tract provides the first barrier against inhaled particulate and gaseous toxicants. Trachea removed from pathogen-free rats were maintained as organ cultures and used to study the effects of coal dust exposure on the synthesis of mucin. The high molecular weight isotopically labeled (^3H -glucosamine, ^{14}C -leucine or ^{35}S -sulfate) mucin could be purified by gel filtration, treatment with testicular hyaluronidase, ion exchange chromatography, delipidation and CsBr density gradient centrifugation. To examine effect of coal dust on mucin production, groups of explant cultures were exposed to media containing coal dust at 100 μg per ml every 2 days for 2 weeks while control cultures were treated with media without dust. Analysis of the spent culture media showed that treatment with dust markedly decreased the production of non-dialysable glycoproteins as well as hyaluronidase-resistant acid-precipitable fraction consisting mainly of mucin. Since the synthesis of protein was not affected to the same extent the decrease in mucin production is not entirely due to cell death. In separate experiments rats were subjected to *in vivo* coal dust exposure in inhalation chambers and tracheae of these and control rats were removed for explant cultures. The incorporation of precursor isotopes into mucin by these explant cultures are being examined. (Supported by U.S. Bureau of Mines through the Generic Mineral Technology Center for Respirable Dust under grant G1135142, project 4210).

No Paper provided.

CORRELATION BETWEEN GRADE OF COAL WORKERS' PNEUMOCONIOSIS AT AUTOPSY WITH ANTEMORTEM X-RAY CLASSIFICATION

F. H. Y. GREEN • V. Vallyathan • R. Althouse • W. Laqueur

University of Calgary, Health Sciences Center, Alberta, Canada and
National Institute for Occupational Safety and Health, Division of Respiratory Disease Studies, Morgantown, WV 26505, USA

ABSTRACT

British studies have shown a good correlation between radiological category of CWP and severity of pneumoconiosis and lung dust burden at autopsy. Other studies have shown that irregular opacities correlate with interstitial fibrosis and also with severity of post-mortem emphysema. The purpose of this study was to investigate the relationships between the type and severity of CWP post-mortem with category of pneumoconiosis on the radiograph. In addition, we investigated the effects of emphysema, interstitial fibrosis, film quality and lung dust burden on X-ray category. The population studied was 700 miners from Beckley, West Virginia, autopsied between 1960 and 1972. X-rays taken within five years prior to death were obtained on 450 cases. All X-rays were reviewed by 3 NIOSH certified B readers. Whole lung sections from inflated lungs were available on all cases. These were reviewed and graded using NIOSH/CAP criteria. The extent and severity of emphysema was graded according to the method of Thurlbeck. Pathologist and radiologist reader variability was found to be acceptable. Results of these studies confirmed the British findings that there is a good correlation between pneumoconiosis and radiographic category and that the higher the grade of pneumoconiosis the better the correlation. In addition, we found that irregular opacities correlated with the degree of interstitial fibrosis and emphysema. Our study also demonstrated that radiology is less sensitive than pathology in detecting mild forms of CWP.

No Paper provided.

EFFECTS OF PLATELET ACTIVATING FACTOR ON VARIOUS PHYSIOLOGICAL PARAMETERS OF NEUTROPHILS, ALVEOLAR MACROPHAGES, AND ALVEOLAR TYPE II CELLS

KNOX VAN DYKE,* Ph.D. • Jean Rabovsky,† Ph.D. • Deloris J. Judy,† B.S. • William H. Pailles,† M.S. • Melanie McPeck† • Natalie A. Sapola† • Vincent Castranova,*† Ph.D.

*Department of Pharmacology and Toxicology

†Division of Respiratory Disease Studies, NIOSH, Morgantown, West Virginia 26505

‡Department of Physiology, West Virginia University, USA

INTRODUCTION

Platelet activating factor (PAF) is a glycerophospholipid (1-0-alkyl-2-acetyl-sn-glycerol-3-phosphoryl choline) which has been shown to mediate a broad range of biological activities.¹⁻³ Its pulmonary actions include contraction of pulmonary tissue,⁴ secretion of leukotrienes from leukocytes,⁵ airway constriction,⁶ pulmonary edema,⁷ and enhanced migration of neutrophils into the airspaces of the lungs.^{8,9}

PAF can be released from several different cell types, such as, basophils, neutrophils and alveolar macrophages, in response to a variety of particulates or membrane stimulants which include zymosan, calcium ionophore, phorbol esters, chemotactic agents, and endotoxin.¹⁰⁻¹³ Therefore, PAF may play an important role in the development of pneumoconioses by mediating pulmonary responses of lung cells to a variety of occupational dusts. To investigate this possibility, we determined the effects of PAF on several physiological parameters of neutrophils, alveolar macrophages, and alveolar type II epithelial cells.

METHODS

Isolation of Cells

Neutrophils were isolated from human blood by dextran settling and centrifugal elutriation.¹⁴ Isolated neutrophils (93% pure) were resuspended in HEPES-buffered medium (145 mM NaCl, 5 mM KCl, 10 mM HEPES, 5 mM glucose, and 1 mM CaCl₂; pH = 7.4). Cell number and volume were determined with an electronic cell counter equipped with a sizing attachment.

Rat alveolar macrophages were obtained by pulmonary lavage with Ca²⁺, Mg²⁺-free Hanks balanced salts solution.¹⁵ Alveolar macrophages (94% pure) were resuspended in HEPES-buffered medium, counted, and sized electronically.

Rat alveolar type II cells were isolated by enzymatic digestion for 35 minutes at 37°C with 40 µ/ml type I elastase and 0.1% collagenase and purified by centrifugal elutriation.^{16,17} Type II cells (92% pure) were resuspended in HEPES-buffered medium for measurement of membrane

potential, oxygen consumption, and trypan blue exclusion. Type II pneumocytes were resuspended in 0.1 M NaCl plus 0.05 M HEPES (pH = 7.8) to measure cytochrome P450-dependent activities and aggregation. Cell size and number were determined electronically.

Measurement of Transmembrane Potential

Membrane potential of isolated cells in suspension was measured using a fluorescent probe, Di-S-C₃,⁵ as described previously for neutrophils,¹⁴ alveolar macrophages,¹⁸ and type II cells.¹⁹ Fluorescence was monitored at excitation and emission wavelengths of 622 and 665 nm, respectively. An increase in the fluorescence emission from the cell suspension indicated membrane depolarization.

Measurement of Respiratory Burst Activity

Release of reactive forms of oxygen by phagocytic cells was determined at 37°C by measuring the generation of chemiluminescence, secretion of hydrogen peroxide, or release of superoxide anion. Chemiluminescence from neutrophils (1 × 10⁶ cells/5 ml of HEPES-buffered medium) was measured in the presence of 1 × 10⁻⁸ M luminol using a liquid scintillation counter operated in the out-of-coincidence mode.²⁰ Chemiluminescence from alveolar macrophages (3 × 10⁶ cells/0.5 ml of HEPES-buffered medium) was measured in the presence of 1 × 10⁻⁵ M luminol using a Berthold 9505 Luminometer.

Hydrogen peroxide release from neutrophils or alveolar macrophages (1 × 10⁷ cells/2.5 ml or 4 × 10⁶ cells/3 ml, respectively) in HEPES-buffered medium containing 2.5 µM scopoletin, and 40 µg/ml horseradish peroxidase (type IX) was monitored fluorometrically at an excitation wavelength of 350 nm and an emission wavelength of 460 nm.^{21,22}

Superoxide anion secretion from neutrophils or alveolar macrophages (1 × 10⁷ cells/2.5 ml or 4.5 × 10⁶ cells/6 ml, respectively) in HEPES-buffered medium was monitored spectrophotometrically at 550 nm as the reduction of 0.12 mM cytochrome C.^{21,15}

Measurement of Cellular Viability

Oxygen consumption was measured at 37°C with an ox-

graph equipped with a Clark electrode. Type II cells (10^7 cells), neutrophils (6.5×10^6 cells), or alveolar macrophages (5×10^6 cells) were suspended in 1.7 ml of HEPES-buffered medium for these measurements.^{16, 21, 23}

Membrane integrity was determined by measuring the exclusion of trypan blue dye under light microscopy.²⁴

Functional Measurements with Type II Cells

Cytochrome P450-dependent ethoxyphenoxazone dealkylase (EtOPhase) (EC 1.14.14.1) activity of type II cells was monitored at 36°C in a direct kinetic assay based upon the formation of a fluorescent product, resorufin, measured at an excitation wavelength of 530 nm and an emission wavelength of 585 nm.¹⁷ NADPH was maintained at 0.5 mM by a glucose-6-phosphate dehydrogenase generating system.

Aggregation of type II cells was monitored at 37°C using a Lumi Aggregometer. Increased aggregation was measured as increased light transmission.

Type II cells used for measurement of cytochrome P450 and aggregation were isolated from rats metabolically induced by pretreatment with β -naphthoflavone. For these assays, cells were suspended in 0.1 M NaCl and 0.05 M HEPES (pH = 7.8).

Statistical Analysis

Data are expressed as means \pm standard errors of *n* experiments conducted with cells obtained from different preparations. Data were analyzed by a Student's *t* test with significance set at $p < 0.05$.

RESULTS

Platelet activating factor can initiate a wide variety of pulmonary responses.^{1,4-9} However, details concerning the cellular mechanisms responsible for the activities of PAF are not fully defined. Therefore, this investigation characterized the actions of PAF on three types of lung cells, i.e., two

types of pulmonary phagocytes (neutrophils and alveolar macrophages) and alveolar type II epithelial cells.

The effects of PAF on pulmonary phagocytes are summarized in Table I. PAF was a direct stimulant of neutrophils *in vitro*. PAF induced substantial depolarization of the plasma membrane which was rapid (peaking within 15 sec after addition of PAF) and transient (returning to the resting level within 2 min). The effect of PAF on the membrane potential (E_m) of neutrophils was dose-dependent, exhibiting a $K_{1/2}$ value of 2.5 μ M. This PAF-induced depolarization was sodium-dependent, i.e., removal of extracellular sodium eliminated the effect. PAF (10 μ M) was also a potent activator of neutrophils, i.e., it induced significant generation of chemiluminescence and release of hydrogen peroxide. As was the case for membrane depolarization, stimulation of the secretory activity of neutrophils by PAF was dependent on extracellular sodium. In contrast to the above responses, *in vitro* treatment of neutrophils with PAF (10 μ M) resulted in only a small increase in superoxide anion release and no significant elevation of oxygen consumption.

As with neutrophils, *in vitro* treatment of alveolar macrophages with PAF (12 μ M) resulted in membrane depolarization. This response was rapid (peaking within 40 sec) and prolonged (not returning to resting E_m). In contrast to neutrophils, *in vitro* treatment of alveolar macrophages with PAN (12 μ M) did not activate the respiratory burst in these cells, i.e., there was little or no PAF-induced increase in chemiluminescence, hydrogen peroxide release, superoxide secretion, or oxygen consumption (Table I). However, PAF (12 μ M) did potentiate activation of alveolar macrophages by zymosan (2 mg/ml), i.e., PAF increases zymosan-stimulated superoxide release by 36% (Figure 1) and zymosan-induced chemiluminescence by 55% (Figure 2).

The *in vitro* effects of PAF on isolated type II cells were also characterized. At levels of 12 μ M or below, PAF did not affect membrane integrity or oxygen consumption, i.e.,

Table I
Effects of Platelet Activating Factor on Phagocytes

Cell Types	E_m	Oxygen Consumption	Superoxide Release	Chemiluminescence	Hydrogen Peroxide Release
Neutrophils	transient depolarization	0	+	+++	+++
Alveolar Macrophages	prolonged depolarization	0	0	0	0

Maximal responses of neutrophils and alveolar macrophages after *in vitro* exposure to 10 μ M or 12 μ M PAF, respectively. The relative magnitude of enhancement is signified by +. No response is signified by 0. Data for each assay are taken from four separate experiments.

trypan blue exclusion was $81 \pm 2\%$ before and $82 \pm 1\%$ after PAF treatment while oxygen consumption levels were 0.23 ± 0.04 and 0.19 ± 0.03 nmoles O_2 /min/ 10^6 cells, respectively. However, PAF ($12 \mu\text{M}$) did cause depolarization of type II cells which was rapid (peaking within 1 min)

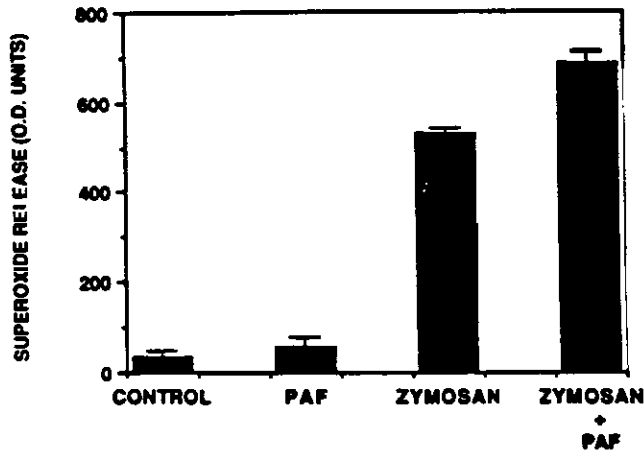

Figure 1. Effects of PAF on superoxide anion release from rat alveolar macrophages. Superoxide secretion at 37°C was monitored spectrophotometrically by measuring the reduction of cytochrome c over 30 minutes at a wavelength of 550 nm. Cells (4.5×10^6 cells/6 ml) were treated *in vitro* with $12 \mu\text{M}$ PAF and/or 2 mg/ml zymosan. Values are means \pm standard errors of four different preparations.

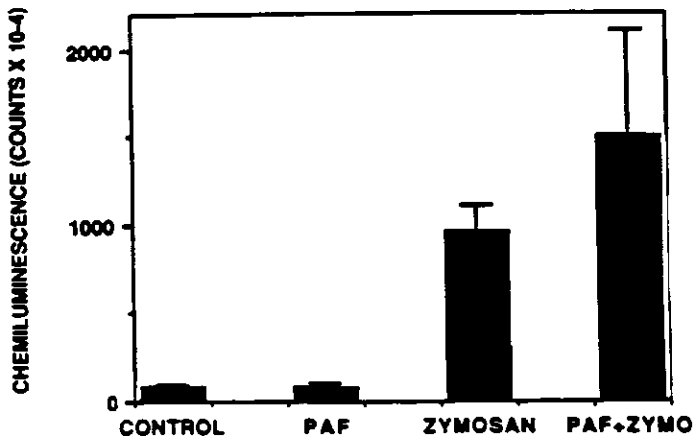

Figure 2. Effects of PAF on chemiluminescence generated from rat alveolar macrophages. Chemiluminescence was measured for 10 minutes at 37°C in the presence of 10^{-5}M luminol. Cells (3×10^6 cells/0.5 ml) were preincubated at 37°C in the presence or absence of $12 \mu\text{M}$ PAF for 15 minutes prior to addition of 2 mg/ml zymosan and measurement of chemiluminescence. Values are means \pm standard errors of three different preparations.

and prolonged. This depolarization exhibited dependence on extracellular sodium. PAF also enhanced the activity of cytochrome P450-dependent ethoxyphenoxazone dealkylase (EtOPhase). A maximum stimulation of 2.5 fold was noted at $10 \mu\text{M}$ PAF (Figure 3). Such activation was demonstrated in intact cells but not in sonicated preparations (Table II) or microsomes. The decline in P450 activity at higher levels of PAF may be due in part to PAF-induced aggregation of type II cells which was significant at PAF levels above $18 \mu\text{M}$ (Figure 4).

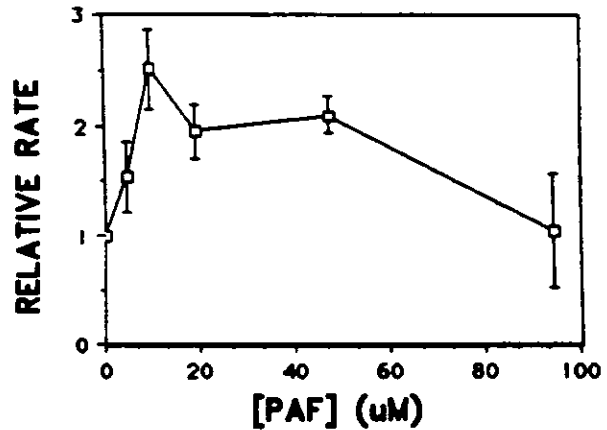

Figure 3. Effect of PAF on cytochrome P450-dependent EtOPhase activity in rat alveolar type II cells. Type II cells were obtained from β -naphthoflavone-treated rats. Cells (1.6 – 2.5×10^6 /ml) were suspended in 0.1M NaCl, 0.5 nM NADPH, and 0.05 M HEPES (pH = 7.8) at 36°C , a fluorescence baseline established, and the reaction initiated with $2.5 \mu\text{M}$ EtOPh. In the absence of PAF, EtOPhase activity of 3 separate preparations of type II cell was 1.06, 1.38, and 0.50 pmoles resorufin formed/min/ 10^6 cells, respectively. Data after addition of PAF are rates relative to these controls (means \pm standard errors).

DISCUSSION

Neutrophils are blood phagocytes which are recruited into the pulmonary air spaces following inhalation of foreign substances, such as, bacteria, virus, or dusts.²⁵ Alveolar macrophages are free lung phagocytes located on the surface of the small airways and the alveoli.²⁶ Upon exposure to microorganisms or occupational dust these phagocytes exhibit a respiratory burst releasing reactive oxygen species, such as, superoxide anion, hydrogen peroxide, and hydroxyl radicals.²⁷⁻²⁹ Evidence indicates that dust exposure may cause hyperactivation of these phagocytes. The resultant secretion of reactive products may result in inflammation, cellular damage, and in extreme cases fibrosis or emphysema.^{30,31}

In this investigation we evaluated the ability of platelet activating factor (a potentially important mediator of pneumo-

Table II
Effect of Sonication on the Responsiveness of Alveolar Type II
Cell Cytochrome P450-Dependent Activity to Platelet Activating Factor

<u>Additive^b</u>	<u>P450-Dependent Activity^a</u>	
	<u>Cells</u>	<u>Sonicate^c</u>
None	16.6 ± 3.4	38.7 ± 5.6
BSA-HEPES	16.2 ± 2.4	38.6 ± 11.0
PAF (19 μM)	34.0 ± 6.4	34.2 ± 4.9

- a) Specific activity expressed as pmoles resorufin formed/min/mg protein. Protein determined by the procedure of Lowry et al. (25). Data are means ± standard errors of two experiments.
- b) Additive: None - 0.1M NaCl, 0.5 mM NADPH, and 0.05M HEPES (pH = 7.8); BSA-HEPES - 10 μl of 0.5% BSA in 0.01M HEPES (pH = 7.8) added to the above solution; PAF - 10 μl of PAF in 0.5% BSA and 0.01M HEPES (pH = 7.8) added.
- c) Disrupted type II cells were obtained by pulse sonication (0.33 sec on, 0.67 sec off) of the cell suspension for 30 seconds at 3 Watts at 2°C.

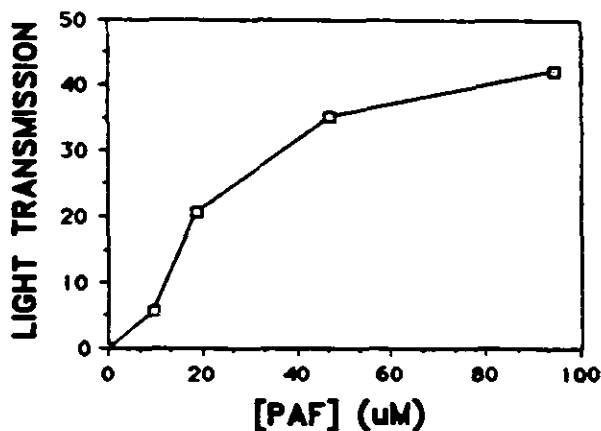

Figure 4. Effect of PAF on aggregation of rat alveolar type II cells. Type II cells were obtained from β-naphthoflavone-treated rats. Cells ($2.5-2.7 \times 10^6$ cells/ml) were suspended in 0.1M NaCl and 0.05M HEPES (pH = 7.8) at 37°C and aggregation monitored as light transmission. Data are means of two experiments.

conioses) to activate phagocytes. The data indicate that PAF depolarizes neutrophils by increasing membrane permeability to sodium. Such depolarization may trigger secretory activity in neutrophils.²⁰ Indeed, PAF does activate neutrophils to secrete hydrogen peroxide and generate chemiluminescence (Table I). However, activation of the respiratory burst is incomplete in neutrophils since PAF does not stimulate oxygen consumption and elevates superoxide release only slightly.

Although PAF depolarizes alveolar macrophages, it does not directly activate a respiratory burst (Table I). However, PAF treatment does prime the cells to be more responsive to subsequent exposure to particles (Figures 1 and 2). Since PAF may be released following dust exposure, the potentiating action of PAF could have important consequences in escalating the cycle of inflammation and tissue damage seen in certain occupational lung diseases.

Cytochrome P450-dependent monooxygenases are responsible for the metabolism of organic chemicals in pulmonary tissue.³² We have shown that within the lung high levels of P450-dependent activities are found in alveolar type II cells.¹⁷ Recent studies have suggested that endogenous factors released from phagocytes may depress P450-dependent activity in hepatocytes.³³⁻³⁵ Since PAF is released from

phagocytes,¹⁰⁻¹³ we tested its effect on P450-dependent activity of type II cells. In contrast to the hepatic system, PAF (a phagocyte-derived mediator) enhances P450-dependent activity of alveolar type II cells (Figure 3). This effect seems to be mediated through the cell membrane, since PAF fails to activate P450 in sonicated cells or microsomes (Table II). It is possible that PAF may alter membrane structures which translate into increased P450 activity. Action of PAF at the plasma membrane is supported by our evidence of PAF-induced changes in membrane permeability to ions and membrane potential. In addition, higher concentrations of PAF alter the membrane surface of type II cell sufficiently to cause aggregation (Figure 4).

In conclusion, PAF may be released from phagocytes following occupational exposures. This PAF would be inflammatory by directly activating neutrophils and potentiating the response of macrophages to particulates. In addition, xenobiotic metabolism by alveolar type II cells would be enhanced affecting the detoxication and/or activation of foreign compounds. The role which these cellular changes play in pneumoconioses remains to be defined.

REFERENCES

- Barquet, P., Rola-Pleszczynski, M.: Platelet-Activating Factor and Cellular Immune Responses. *Immunol. Today* 8:345-352 (1987).
- Benveniste, J., Tence, M., Varenne, P., Bidault, J., Bouillet, C., Polonsky, J.: Platelet Activating Factor. *Comptes Rendus hebd. S'enc Acad. Sci. Paris* 289D:1037-1040 (1979).
- Demopoulos, C.A., Pinckard, R.N., Hanahan, D.J.: Platelet Activating Factor. *J. Biol. Chem.* 254:9355-9358 (1979).
- Stimler, N.P., D'Flaherty, J.T.: Spasmogenic Properties of Platelet-Activating Factor: Evidence for a Direct Mechanism in the Contractile Response of Pulmonary Tissue. *Am. J. Pathol.* 113:75-84 (1983).
- Lin, A.H., Morton, D.R., Gorman, R.R.: Acetyl Glyceryl Ether Phosphoryl-choline Stimulates Leukotriene B₄ Synthesis in Human Polymorphonuclear Leukocytes. *J. Clin. Invest.* 70:1058-1065 (1982).
- Cuss, F.M., Dixon, C.M.S., Burnes, P.J.: Effects of Inhaled Platelet Activating Factor on Pulmonary Function and Bronchial Responsiveness in Man. *Lancet* ii:189-192 (1986).
- Pinckard, R.N., Halonen, M., Pulmer, J.D., Butler, C., Shaw, J.O., Henson, P.M.: Intravascular Aggregation and Pulmonary Sequestration of Platelets during IgE-Induced Systemic Anaphylaxis in the Rabbit: Abrogation of Lethal Anaphylactic Shock by Platelet Depletion. *J. Immunol.* 119:2185-2191 (1977).
- Humphrey, D.M., Hanahan, D.: Induction of Leukocyte Infiltrates in Rabbit Skin by Acetyl Glyceryl Ether Phosphorylcholine. *Lab. Invest.* 47:227-234 (1982).
- Czarnetzki, B.M., Benveniste, J.: Effect of 1-O-Octadecyl-2-O-Acetyl-sn-Glycerol-3-Phosphocholine (PAF-Acether) on Leukocytes. I. Analysis of the In Vitro Migration of Human Neutrophils. *Chem. Phys. Lipids* 29:317-326 (1981).
- Benveniste, J., Henson, P.M., Cochrane, C.G.: Leukocyte-Dependent Histamine Release from Rabbit Platelets. *J. Exp. Med.* 136:1356-1377 (1972).
- Betz, S.J., Henson, P.M.: Production and Release of Platelet-Activating Factor (PAF): Dissociation from Degranulation and Superoxide Production in Human Neutrophils. *J. Immunol.* 125:2756-2763 (1980).
- Arnoux, B., Duval, B.: Release of Platelet-Activating Factor (PAF-Acether) from Alveolar Macrophages by the Calcium Ionophore A23187 and Phagocytosis. *Eur. J. Clin. Invest.* 10:437-441 (1980).
- Rylander, R., Beijer, L.: Inhalation of Endotoxin Stimulates Alveolar Macrophage Production of Platelet-Activating Factor. *Am. Rev. Respir. Dis.* 135:83-86 (1987).
- Jones, G.S., Van Dyke, K., Castranova, V.: Purification of Human Granulocytes by Centrifugal Elutriation and Measurement of Transmembrane Potential. *J. Cell. Physiol.* 104:425-431 (1980).
- Sweeney, T., Castranova, V., Bowman, L., Miles, P.R.: Factors which Affect Superoxide Anion Release from Rat Alveolar Macrophages. *Exp. Lung Res.* 2:85-96 (1981).
- Jones, G.S., Miles, P.R., Lantz, R.C., Hinton, D.E., Castranova, V.: Ionic Content and Regulation of Cellular Volume in Rat Alveolar Type II Cells. *J. Appl. Physiol.: Respir. Environ. Exercise Physiol.* 53:258-266 (1982).
- Rabovsky, J., Judy, D.J., Sapola, N.A., Pailles, W.H., McPeck, M., Castranova, V.: Cytochrome P450-Dependent Alkoxyphenoxazone Dealkylase Activity in Rat Alveolar Type II Cells: Effect of Pretreatment with β -Naphthoflavone. *Cell Biochem. Funct.* in press.
- Castranova, V., Bowman, L., Miles, P.R.: Transmembrane Potential and Ionic Content of Rat Alveolar Macrophages. *J. Cell. Physiol.* 101:471-480 (1979).
- Castranova, V., Jones, G.S., Miles, P.R.: Transmembrane Potential of Isolated Rat Alveolar Type II Cells. *J. Appl. Physiol.: Respir. Environ. Exercise Physiol.* 54:1511-1517 (1983).
- Jones, G.S., Van Dyke, K., Castranova, V.: Transmembrane Potential Changes Associated with Superoxide Release from Human Granulocytes. *J. Cell. Physiol.* 106:75-83 (1981).
- Van Dyke, K., Matamoros, M., Van Dyke, C.J., Castranova, V.: Calcium Ionophore-Stimulated Chemiluminescence (CL) from Human Granulocytes: Evidence that A23187-Induced Chemiluminescence Originates from Arachidonic Acid Metabolism. *Microchem. J.* 28:568-579 (1983).
- Van Scott, M.R., Miles, P.R., Castranova, V.: Direct Measurement of Hydrogen Peroxide Release from Rat Alveolar Macrophages: Artifactual Effect of Horseradish Peroxidase. *Exp. Lung Res.* 6:103-114 (1984).
- Castranova, V., Bowman, L., Miles, P.R., Reasor, M.J.: Toxicity of Metal Ions to Alveolar Macrophages. *Am. J. Indus. Med.* 1:349-357 (1980).
- Castranova, V., Bowman, L., Wright, J.R., Colby, H., Miles, P.R.: Toxicity of Metallic Ions in the Lung: Effects on Alveolar Macrophages and Alveolar Type II Cells. *J. Tox. Environ. Health* 13:845-856 (1984).
- Lowry, O.H., Rosebrough, N.J., Farr, A.L., Randall, R.J.: Protein Measurements with the Folin Phenol Reagent. *J. Biol. Chem.* 193:265-275 (1951).
- Castranova, V., Robinson, V.A., Tucker, J.H., Schwegler, D., Rose, D.A., DeLong, D.S., Frazer, D.G.: Time Course of Cotton Dust in Guinea Pigs and Rats. In: Proc 11th Cotton Dust Res Conf. R.R. Jacobs and P.J. Wakelyn (eds). Nat. Cotton Council, Memphis, TN, pp 79-83 (1977).
- Weibel, E.R.: Morphological Basis of Alveolar-Capillary Gas Exchange. *Physiol. Rev.* 53:419-495 (1973).
- DeChatelet, L.R.: Initiation of a Respiratory Burst in Human Polymorphonuclear Neutrophils: A Critical Review. *Res J. Reticuloendothel. Soc.* 24:73-83 (1978).
- Johnston, R.B.: Oxygen Metabolism and the Microbicidal Activity of Macrophages. *Fed. Proc. Fed. Am. Soc. Exp. Biol.* 37:2759-2764 (1978).
- Weiss, S.J., LoBuglio, A.F.: Biology of Disease: Phagocyte Generated Oxygen Metabolites and Cellular Injury. *Lab Invest.* 47:5-18 (1982).
- Halliwell, B.: Oxidants and Human Disease: Some New Concepts. *FASEB J.* 1:358-364 (1987).
- Minchin, R.F., Boyd, M.R.: Localization of Metabolic Activation and Deactivation Systems in the Lung: Significance of the Pulmonary Toxicity of Xenobiotics. *Ann. Rev. Pharmacol. Toxicol.* 23:217-238 (1983).
- Peterson, T.C., Williams, A.E.: Depression of Peripheral Blood Monocytes Aryl Hydrocarbon Hydroxylase Activity in Patients with Liver Disease: Possible Involvement of Macrophage Factors. *Hepatology* 7:333-337 (1987).
- Williams, J.F.: Induction of Tolerance in Mice and Rats to the Effect of Endotoxin to Decrease the Hepatic Microsomal Mixed-Function Oxidase System. Evidence for a Possible Macrophage-Derived Factor in the Endotoxin Effect. *Inter. J. Immunopharmacol.* 7:501-509 (1985).
- Wooles, W.R., Munson, A.E.: The Effects of Stimulants and Depressants of Reticuloendothelial Activity on Drug Metabolism. *J. Retic. Soc.* 9:108-119 (1971).

This research has been supported by the Department of the Interior's Mineral Institute Program administered by the United States Bureau of Mines through the Generic Mineral Technology Center for Respirable Dust under grant number G1175142.

EVALUATION OF THE FIBROGENIC POTENTIAL OF SANDBLASTING SUBSTITUTES

Y. HAMMAD • B. Bozelka • H. Abdel-Kader • C. Reynolds

Tulane School of Medicine, Pulmonary Section, New Orleans, LA, USA

ABSTRACT

Sandblasting may lead to severe and progressive silicosis. Sand substitutes, derived from slag and coal ash, are now increasingly being used. They are comprised of amorphous silicates of Fe, Al, Ca, and Mg in various proportions. The fibrogenic potential of STANBLAST, a sand substitute derived from coal ash, was evaluated in a rat model. Male rats were exposed by inhalation to the substitute ($10.8 \pm 3.5 \text{ mg/m}^3$) for 6 hrs/day, 5 days/week for one year. Rats were sacrificed 6, 12, 18 and 24 months from onset of exposure and were evaluated for: lung weights, mineral burden, hydroxyproline (HP) content and histology using H & E, Gomoris' silver impregnation and Masson's trichrome stains. Lung weights and HP of exposed rats were not statistically significant from controls. Histologic examination of lung tissue of exposed rats revealed a nonfibrogenic tissue reaction to the dust. Small distinct foci of alveolar macrophages containing dust particles were diffusely scattered throughout the lung parenchyma. These cellular collections were frequently found in peribronchial, perivascular and subpleural locations. Although extracellular particles were also evident, cell lysis, acute inflammation and collagen deposition were absent. Absence of biochemical changes corroborate these findings.

No Paper provided.

STUDIES OF SILICOSIS AMONG MIGRANT WORKERS (REPORT 2) MORTALITY AMONG MIGRANT WORKERS FOR TUNNELLING WORKS

YUICHI YAMADA, M.D. • Hideaki Nakagawa, M.D. • Yoshiharu Okumura, M.D.
• Yuko Morikawa, M.D. • Masaji Tabata, M.D. • Shunichi Kawano, M.D.

Department of Hygiene and Department of Public Health, Kanazawa Medical University
1-1, Daigaku, Uchinada, Ishikawa, 920-02 Japan

ABSTRACT

We investigated the morbidity and mortality among migrant workers exposed to dust, such as that encountered during tunnel construction. Questionnaires on occupational pattern were sent to all male inhabitants aged 30 or over in a selected area between 1977 and 1978. Two thousand two hundred and fifty-six respondents were followed-up until the end of July, 1985. Among those who died, the causes and dates of death were confirmed by death certificates.

The mortality rate per 1,000 person-years of migrant workers who had worked in jobs with exposure to dust was 23.0, significantly higher than that of migrant workers not exposed to dust (15.5) and that of non-migrant workers whose jobs did not expose them to dust (9.5). The mortality rate was particularly high in migrant workers exposed to dust who were in age group 50 to 79.

Among migrant workers exposed to dust, the highest mortality rate per 1,000 person-years was associated with malignant neoplasms (5.4) followed by pulmonary tuberculosis (4.9), pneumoconiosis (4.0), heart diseases (3.6) and cerebrovascular diseases (2.2). The mortality rates for pulmonary tuberculosis and pneumoconiosis among migrant workers exposed to dust were significantly higher than those among non-migrant workers.

INTRODUCTION

In farming households in parts of Japan, it is impossible to subsist on the income from farming alone due to the natural and social environment, and seasonal migration of the working population for employment has long been a customary phenomenon. In Japan, such a practice is called "dekasegi" or working-away-from-home. These workers are generally employed under inferior working conditions, and long working hours as well as insecurity of their positions as subcontracting adds to their liability to work-related accidents and occupational diseases.

As shown in Report 1,¹ the eastern part of Toyama prefecture in Japan is well known as being one of the areas that supply many migrant workers who engage in tunnel construction for the development of electric power plant. We^{1,2} conducted a questionnaire survey on the workers of this area for the screening of silicosis patients combined with a subsequent physical examination for suspicious cases, and demonstrated a prevalence of silicosis in 18% of the male population over 30 years of age, and 84% of the migrant workers engaged in dust-exposure operations.

Silicosis generally shows an unfavorable prognosis, and the symptoms are known to progress gradually even after cessation of exposure to dust.³ This high prevalence of silicosis

is considered to exert profound effects on health conditions, mortality rate, and causes of death in this area. Health management of migrant workers engaged in dust-exposure operations, therefore, must be regarded as an important problem of local health administration.

METHODS

A questionnaire survey was conducted on the male population over 30 years of age residing in the eastern Toyama prefecture for an epidemiological study of silicosis during the summer of 1977 and 1978. The questionnaire forms were distributed, and each examinee was requested to give written answers to questions mainly concerning his occupational history. Replies were obtained from 2260 people (87% of all those questioned) including those who later supplemented their initial inadequate entries.^{1,2}

Analysis of data was carried out, in which survival, death, or loss of them from the area of the survey by the end of June, 1985 were examined. Causes of death were studied by death certification, and classified according to the 9th Revision of the Basic Classification of Causes of Death.

The mortality rate was calculated by the person-year method. The examinees were divided into three groups according to whether they had done migrant work and of the exposure

to dust for comparison of the mortality rate. Statistical significance was corrected for age and tested by the Mantel-Haenzel's X^2 method.

After eliminating those who could not be followed up for reasons such as leaving the area at an unknown date, 2116 people (94% of those returning the questionnaire) were included in this study. Table I shows the number of examinees and the duration of their follow-up in each occupational history group. The study encompassed a total of 15253.75 person-years, and the mean duration of follow-up per examinee was 7.2 person years.

RESULTS

Mortality and Age

During the observation period from the summer of 1977 (from the summer of 1978 in part of the area) to the end of June, 1985, 218 subjects (9.8% of all the subjects) died. Death occurred in 16% of migrant workers who engaged in dust-exposure occupations such as tunnel construction as opposed to 7.0% of those who had no history of migrant works or occupational dust exposure. The death rate in those who had a history of migrant work but no dust exposure was 11.2%.

The incidence of mortality per 1,000 person-years was highest (23.0) in those with a history of dust exposure during migrant work, followed by those with a history of migrant work but not of dust exposure (15.5), and lowest in those with no history of migrant work or dust exposure (9.5). The mortality rate in each age group classified according to the age is shown in Table II: It was higher by 200-250 in those with a history of dust exposure during migrant work than in those without a history of migrant work or dust exposure in all age groups from 50 to 79. The differences between the two groups were significant ($p < 0.01$) in the 3 age groups between 50 and 79 years. The mortality was also slightly higher in those with a history of migrant work but not of dust exposure except in those in their 50's.

Mortality and Relevant Factors

For the migrant workers with dust exposure the ratio of actual number of death to expected number of death (A/E

ratio(%)) distributed separately by relevant factors, such as cigarette consumption, total duration of migrant works with dust exposure and the number of respiratory symptoms (those as recorded at the initial survey), were calculated using the number of deaths and age distribution of overall migrant workers with dust exposure as the standard. For the migrant workers with exposure to dust, there was no significant difference of the A/E ratio among the groups divided by smoking consumption.

The A/E ratio distributed by duration increased in a graded fashion. The A/E ratio was significantly higher in the group who had worked for 30 or more years than in those who had worked less than 19 years (Table III).

The seven symptoms were investigated in present survey. These symptoms are: the production of phlegm in the morning or during the day on most days for at least three months of the year, the occurrence of cough in the morning or during the day on most days for at least three months of the year, the presence of shortbreathness graded by the criterion of Hugh-Jones, the occurrence of wheezing, the occurrence of nasal obstruction or nasal discharge, the frequent occurrence of colds and the occurrence during the past three years of chest illness which kept from usual activities for as much as a week. Table IV shows the A/E ratio for migrant workers with exposure to dust reporting the number of symptoms. The A/E ratio distributed by the number of symptom increased progressively as the prevalence of symptoms increased. The A/E ratio was significantly higher in the group with five or more symptoms than in those without symptoms.

Mortality and Cause of Death

Table V shows the incidence of mortality from different causes in each occupational history group. The mortality from malignant neoplasms was highest in those without a history of migrant work or dust exposure (3.2 per 1,000 of population over 30 years), followed by heart diseases (2.4), cerebrovascular diseases (1.8), suicide (0.3) and pneumonia and bronchitis (0.2). In those with a history of migrant work but not of dust exposure, the mortality due to cerebrovascular diseases was highest (4.9), followed by malignant neoplasms (4.4), pneumonia and bronchitis (1.9), and heart diseases and suicide (1.5 for both).

Table I
Subjects Investigated

	Non-migrant worker	Migrant worker without a history of dust exposure	Migrant worker with a history of dust exposure
No. of subjects	1,185	286	845
Total person-years of observation	8719.5	2,060	4474.25
Mean person-years of observation per person	7.36	7.20	8.94

In the above two groups, so called adult diseases (diseases closely associated with aging) accounted for large percentages of death but pulmonary tuberculosis was not observed. However, malignant neoplasms along with pulmonary tuberculosis was the most common cause of death (5.4 and 4.9 respectively) in those with a history of dust exposure during migrant work. Moreover, pulmonary tuberculosis in this group was invariably complicated by silicosis. In this group, the mortality from pneumoconiosis was 4.0, heart diseases 3.6, and cerebrovascular diseases 2.2, besides adult diseases,

disorders, presumably related to dust-exposure activities such as pulmonary tuberculosis, pneumoconiosis, accounted for large percentages of death in this group.

Mortality with Age and Cause of Death

Since the 3 occupational history groups varied in the age distribution and duration of follow-up, the A/E ratio was calculated for the two groups with a history of migrant work (Table VI), using the number of death in the group without a

Table II
The Number of Deaths and Mortality Rate per 1,000 Person-Years According to the Age

	Non-migrant worker	Migrant worker without a history of dust exposure	Migrant worker with a history of dust exposure
Total	83 (9.52)	32 (15.53)	103 (23.02) ***
Age 30 - 39	2 (1.09)	0 (-)	0 (-)
40 - 49	6 (2.42)	3 (6.46)	6 (6.10)
50 - 59	13 (6.36)	2 (3.25)	21 (12.73) *
60 - 69	15 (10.61)	6 (13.14)	29 (26.16) **
70 - 79	26 (33.22)	11 (42.51)	34 (67.23) **
80 -	21 (124.81)	10 (142.35)	13 (133.68)

* $P < 0.05$, ** $P < 0.01$, *** $P < 0.001$

(Comparison with the group without a history of migrant work)

Table III
Effect of Duration of Migrant Works with Dust Exposure on Mortality in Migrant Workers

	Duration of migrant works with dust exposure (years)			
	- 9	10 - 19	20 - 29	30 -
Actual No. of deaths	23	14	24	28
Expected No. of deaths^a	35.9	21.3	22.9	18.5
A/E ratio (%)	64.0	65.8	104.8	151.0 *

^a. The number of deaths and age distribution of overall migrant workers with exposure to dust are standard.

* There is a significant difference ($P < 0.05$) between a group with more than 30 year duration and 2 groups with less than 19 year duration of migrant works.

Table IV
Effect of Respiratory Symptom and Total Duration on Mortality in Migrant Workers with Dust Exposure

	Number of symptoms ^b			
	0	1~2	3~4	5~
Actual No. of deaths	17	34	21	19
Expected No. of deaths ^a	31.8	35.8	21.4	12.1
A/E ratio (%)	53.5	95.0	98.2	157.6 [*]

a. The respiratory symptoms investigated are the occurrence of cough, phlegm, shortness of breath, wheezing, nasal obstruction or nasal discharge, chest illness which has kept from usual activities for a week and the frequent occurrence of common colds.

b. The number of deaths and age distribution of overall migrant workers with dust exposure are standard.

* There is a significant difference ($P < 0.05$) between a group without symptom and a group with 5 or more symptoms.

history of migrant work as the expected number. In the group with a history of migrant work but not of dust exposure, the overall A/E ratio was relatively high (117); among individual causes, high causes for cerebrovascular diseases (178%), pneumonia and bronchitis (774%), and accidents or suicides (326%) were noted. The group with a history of dust exposure during migrant work showed a still higher overall A/E ratio (192%); the value was moderately increased for lung cancer (176%) as well as accidents and suicides (351%), but smaller for ischemic heart disease (76%). In this group, the A/E ratios for pneumoconiosis and pulmonary tuberculosis were markedly increased, as might be expected.

DISCUSSION

Silicosis, a well established occupational disease, develops due to inhalation of dust containing free SiO₂. Measures to protect workers from this disease have been attempted by legislation (Special Act for Protection of Workers from Silicosis and other Diseases, Pneumoconiosis Law) since 1955. However, the number of clinical cases of pneumoconiosis has been increasing every year, and among these patients, a rapid increase in the proportion of migrant workers engaged in tunnel construction has been noted.⁴ Eastern Toyama and southern Oita in Japan have a long history of attracting migrant workers for tunnel construction and have shown abnormally high incidences of silicosis.

Une et al.⁵ and Hisashige et al.⁶ studied the causes of death and their interrelationships in southern Oita by dynamic statistical analysis of mortality. According to these studies, the overall mortality among the male population of southern Oita was significantly higher than the national average. The mortalities due to silicotic tuberculosis, pulmonary tuberculosis (Classification of causes of death was made according to the 8th Revision), all types of cancer, gastric cancer,

pneumoconiosis, and work-related accidents in the industrial sector were also high.⁵ These tendencies except for the mortality due to accidents, were more notable in the areas densely populated by migrant workers than in other areas of southern Oita.⁶ Furthermore, death due to silicotic tuberculosis and pneumoconiosis occurred more frequently among those engaged in tunnel construction.⁵ These findings suggested that the accumulation of silicosis patients associated with the migration of workers engaged in tunnel construction exerted grave effects on the health status of the region.

A study of morbidity or mortality with its impact on the local health status generally requires accurate recording of clinical courses from the onset of the disease to the complete recovery or death of patients during a long-term follow-up of the follow-up of the same group of subjects. For this reason, we conducted a follow-up study with a mean duration of 7.2 years (maximum, 8.0 years) in those who were previously examined in a questionnaire survey for all male residents over 30 years of age of eastern Toyama Prefecture.

A high mortality among workers engaging in dust-exposure occupations was demonstrated in follow-up studies in coal miners.⁷⁻⁹ The mortality was particularly high among retired workers, pneumoconiotic patients exhibiting severe radiographic manifestations, those with subjective symptoms, smokers, and those with decreased pulmonary function.⁷⁻⁹ Migrant workers have been observed often to suffer from deterioration of chronic diseases due to stressful working conditions and to develop such fatal conditions as apoplexy and heart failure. The results of follow-up of our subjects with an experience of migrant work were consistent with the above observations. In those engaged in dust-exposure occupations, however, work-related diseases such as pneumoconiosis and pulmonary tuberculosis appeared to be more responsible for the poor health status than the adverse conditions commonly

Table V
The Number of Deaths from Different Causes

Causes of deaths	ICD code ^a	Non-migrant worker	Migrant worker without a history of dust exposure	Migrant worker with a history of dust exposure
All causes	000 - 999	83 (9.52) ^b	32 (15.53)	103 (23.02)
Cerebrovascular diseases	430 - 458	16 (1.84)	10 (4.85)	10 (2.23)
Ischemic heart diseases	410 - 414	8 (0.92)	0 (-)	4 (0.89)
Non-ischemic heart diseases	393-398, 402, 415, 416, 420-429	13 (1.49)	3 (1.46)	12 (2.68)
Malignant neoplasms	140 - 208	28 (3.21)	9 (4.37)	24 (5.36)
Stomach	151	9 (1.03)	2 (0.91)	6 (1.34)
Trachea, Bronchus and Lung	162	7 (0.80)	2 (0.97)	8 (1.79)
Pneumonia and Bronchitis	480 - 486 490, 491	2 (0.23)	4 (1.94)	2 (0.45)
Pulmonary tuberculosis	011	0 (-)	0 (-)	22 (4.92)
Pneumoconiosis	500 - 508	0 (-)	0 (-)	18 (4.02)
Accidents	E800 - E848 E880 - E899 E910 - E929	1 (0.11)	1 (0.49)	7 (1.58)
Suicides	E950 - E959	3 (0.34)	3 (1.46)	2 (0.45)
Others		12 (1.38)	2 (0.97)	2 (0.45)

^a Classified according to the 9th Revision of the Basic Classification of Causes of Death.

^b Figures in brackets are the crude mortality rates per 1,000 person-years over 30 years.

affecting all migrant workers. Although there was no relationship between smoking and mortality, the mortality increased progressively as the duration of migrant works with dust exposure increased in length and as the prevalence of respiratory symptoms increased.

Effect of dust exposure in migrant workers must be assessed by a long-term observation of their physical conditions besides the analysis of mortality. Progression of the disease was suggested to be more rapid in those engaged in tunnel

construction.¹⁰ We also noted a rapid development of subjective complaints and a decrease in pulmonary function over a short period of time in migrant workers engaged in dust exposure operation.¹¹ Radical approaches are considered to be necessary for health management of migrant tunnel construction workers and silicosis patients, who are offered inadequate administrative health-related service, as shown in Report 1,¹ and turn to medical aid only after considerable progression of the disease.

Table VI
The Ratio of Actual Number of Death to Expected Number of Death

	Migrant worker without a history of dust exposure			Migrant worker with a history of dust exposure		
	Actual No. of deaths	Expected No. of deaths ^a	A/E ratio (%)	Actual No. of deaths	Expected No. of deaths ^a	A/E ratio (%)
All causes	32	27.5	116.5	103	53.7	191.8 ***
Cerebrovascular diseases	16	5.6	177.9	10	9.9	101.4
Ischemic heart diseases	0	2.9	0.0	4	5.3	76.0
Non-ischemic heart diseases	3	4.9	61.3	12	8.2	146.3
Malignant neoplasms	9	8.4	107.2	24	18.7	128.3
stomach	2	2.3	86.1	6	5.6	108.0
Trachea, Bronchus and Lung	2	2.2	92.7	8	4.6	175.7
Pneumonia and bronchitis	4	0.5	773.7	2	1.0	192.2
Pulmonary tuberculosis	0	0	—	22	0	— ***
Pneumoconiosis	0	0	—	18	0	— ***
Accidents and Suicides	4	1.2	325.5	9	2.6	350.7

^a The number of deaths and age distribution in the group of non-migrant worker are standard

*** P < 0.001

REFERENCES

1. Nakagawa, H.: Studies of Silicosis among Migrant Workers (report 1) The Frequent Occurrence and Relevant Factors of Silicosis, *VIIth International Pneumoconiosis Conference*, Pittsburgh, USA (August 23-26, 1988).
2. Nakagawa, H.: Studies on Silicosis as Reported in Migrant Workers. *Jpn. J. Hyg.*, 35:728-736 (1980).
3. Ebihara, I.: Pneumoconiosis among Workers Who Left M. Copper Mine due to Its Closure. *J. Sci. Labour*, 50:831-844 (1974).
4. Yamazaki, Y.: Processes and Factors Concerning the Frequent Occurrence of Pneumoconiosis among Migrant Workers for Tunnel Construction. *J. J. Public Health*, 30:336-348 (1983).
5. Une, H. and Wake, K.: A Study of Pneumoconiosis among Migrant Workers. *J. Sci. Labour*, 58:469-477 (1982).
6. Hisashige, A. et al.: An Analysis of the Mortality Patterns in the Area Supplying Tunnel Workers away from Home. *Jpn. J. Ind. Health*, 25:245-261 (1983).
7. Ortmeier, C.E. et al.: The Mortality of Appalachian Coal Miners, 1963 to 1971. *Arch. Environ. Health*, 29:67-72 (1974).
8. Ortmeier, C.E. et al.: Life Expectancy of Pennsylvania Coal Miners Compensated for Disability. *Arch. Environ. Health*, 27:227-230 (1973).
9. Higgins, I.T.: Chronic Respiratory Disease in Mining Communities. *Ann. New York Acad. Sci.*, 200:197-211 (1972).
10. Suda, K.: The Incidence of Serious Pneumoconiosis and the Pneumoconiosis Law. *J. Sci. Labour*, 58:71-80 (1982).
11. Nakagawa, H.: An Epidemiological Study on Silicosis Occurring Frequently Among the Inhabitants in the Eastern Part of Toyama Prefecture. *J. Jusen-Med. Soc.*, 91:261-279 (1982).

STUDIES OF SILICOSIS AMONG MIGRANT WORKERS (REPORT 1) THE FREQUENT OCCURRENCE AND RELEVANT FACTORS OF SILICOSIS

HIDEAKI NAKAGAWA, M.D. • Yuichi Yamada, M.D. • Yoshiharu Okumura, M.D.
• Yuko Morikawa, M.D. • Masaji Tabata, M.D. • Shunichi Kawano, M.D.

Department of Public Health and Department of Hygiene, Kanazawa Medical University
1-1, Daigaku, Uchinada, Ishikawa, 920-02 Japan

ABSTRACT

During the 1970's many cases of serious silicosis occurred among migrant workers doing tunnel construction. Migrant workers are known in Japanese as "dekasegi". This term refers to workers who migrate seasonally from their home towns to areas where work is more available. The eastern part of Toyama, Japan is well known as being one of the areas which supply many migrant workers doing tunnel construction.

Questionnaires were sent to all male inhabitants aged 30 or over in the five selected areas between 1977 and 1978. Nine hundred and thirty-one of respondents (41%) had worked as migrant workers. Of these, 645 men (69%) had worked on the jobs with exposure to dust such as tunnel construction. Of this number, 566 men were examined by chest roentgenography. Silicosis was found in 84% (477 cases). These patients included 248 cases of category 1, 122 cases of category 2, 54 cases of category 3 and 53 cases of category 4 silicosis.

Most of the patients retired and returned to their home towns without having been given any diagnosis and medical care at their places of employment. The silicosis in 332 cases (70% of the total number of disease patients) was first detected in the course of our research.

It was considered that the important social factors which may have caused the frequent occurrence of silicosis were poor working and living conditions of migrant workers in the tunnel and poor measures for prevention of silicosis such as health examinations, educations about silicosis and wearing of a dust respirator.

INTRODUCTION

Migrant work is defined in Japan to be employment for 1 month or more to less than a year away from the place of permanent residence followed by return to the place of residence, and such a practice is called "dekasegi". Migrant workers have often been victims of deterioration of health, work-related accidents, and occupational diseases as they have generally been forced to work for long hours under inferior working environments in addition to instability of the position and poor health management under the subcontract and the sub-subcontract employment systems.¹

Eastern Toyama Prefecture, which is under the jurisdiction of Kurobe Health Center, is one of the areas with a high incidence of silicosis among migrant workers.^{2,3} In this study, the statistical facts and the state of silicosis patients in this jurisdiction were surveyed, and factors in the high incidence and severity of their condition were examined.

METHODS

Five areas under the jurisdiction of Kurobe Health Center, Toyama Prefecture (Figure 1) were selected arbitrarily, and questionnaire surveys primarily concerning the occupational

history were conducted in summer, 1977 and 1978 in all males in these areas aged 30 years or above. The questionnaires were distributed to each subject and filled in by the subject himself. Including those whose answers were initially incomplete and who have been incorporated in the survey later through follow-up works, a total of 2,260 individuals (87% of the 2,604 to whom the questionnaires were sent) were available for the study. On the basis of the questionnaires, screening for pneumoconiosis was carried out for those who had engaged in migrant work in occupations involving dust exposure. The screening consisted of interview, somatometry, direct chest roentgenographic examination, lung function test, and arterial blood gas analysis. The radiograms were evaluated by 5 doctors including the authors according to the classification of the Pneumoconiosis Law of Japan,⁴ which is based on ILO/UICC Classification, 1971. When opinion differed among the doctors, the diagnosis was made by the majority rule.

RESULTS

Results of Questionnaires and Screening for Pneumoconiosis

Table I shows the results of the questionnaires about migrant

work carried out in the summer of 1977 and 1978. Nine hundred and thirty-one individuals, or 41% of the valid respondents, had experienced migrant work. Of these 931 subjects, 645 (29% of valid respondents) had been exposed to dust in work. Tunnel construction was predominant among the works involving dust exposure, accounting for nearly

90%, followed by mining of minerals other than coal and coal-mining.

Of the 645 subjects, 566 have undergone screening for pneumoconiosis, the results of which are shown in Table II. Signs of silicosis were observed in 477 subjects (84% of those

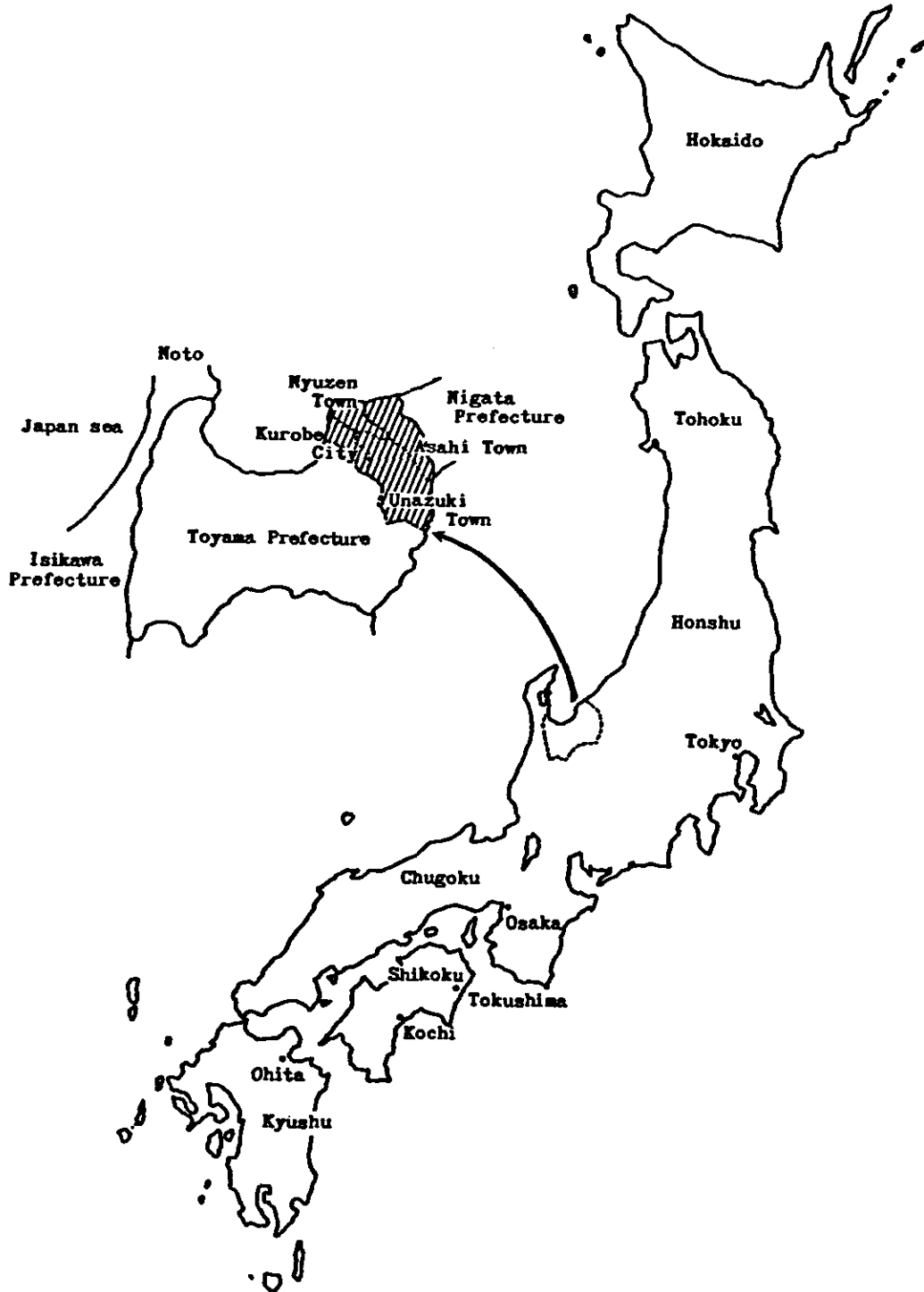

Figure 1. Study area and its location in Japan.

Table I
The Number of Migrant Workers Based on Questionnaires

	Total	Age group (years)						
		30 ~ 39	40 ~ 49	50 ~ 59	60 ~ 69	70 ~ 79	80 ~	Unknown
No. of respondents	2260 * (100)	496 (100)	643 (100)	531 (100)	376 (100)	177 (100)	33 (100)	4
Migrant Workers	931 (41.2)	83 (16.7)	287 (44.6)	265 (49.9)	194 (51.6)	87 (49.2)	15 (45.5)	
Migrant Workers with exposure to dust	645 (28.5)	42 (8.5)	203 (31.6)	196 (36.9)	141 (37.5)	52 (29.4)	11 (33.3)	

* Figures in brackets are percentage

Table II
Chest Roentgenographic Findings of Silicosis in Migrant Workers with Exposure to Dust by the Age at Their First Examination in the Course of This Research

	Total	Age group (years)					
		30 - 39	40 - 49	50 - 59	60 - 69	70 - 79	80 -
No. of subjects	566 ** (100)	25 (100)	160 (100)	200 (100)	134 (100)	43 (100)	4 (100)
Silicosis patients	477 (84.3)	14 (56.0)	124 (77.5)	180 (90.0)	112 (83.6)	41 (95.3)	4 (100)
Classification of silicosis *							
1	248	10	89	85	58	23	3
2	122	4	27	50	31	10	0
3	54	0	16	19	17	2	0
4	53	0	14	28	8	6	1

* Classification of silicosis according to the Pneumoconiosis Law of Japan

** Figures in brackets are percentages

undergoing screening). According to the roentgenographic categories, 248 (52%) belonged to type I, 122 (26%) to type II, 5 (11%) to type III, and 53 (11%) to type IV silicosis.

Table III shows the relationship between the X-ray grading of the disease and the duration of dust exposure. Silicosis was noted in 94%, 80%, and 70% of those exposed to dust for 20 years or more, 10-19 years, and less than 10 years, respectively, indicating an increase in the incidence with the duration of dust exposure.

The subjective symptoms were examined with regard to cough (continuing for 3 months or more per year), phlegm (continuing for 3 months or more per year), shortness of breath (Hugh-Jones grade III or more severe dyspnea),

wheezing, and palpitation (Table IV). Cough was reported by 24%, phlegm by 25%, shortness of breath by 29%, wheezing by 19%, and palpitation by 17% of patients with silicosis. The frequencies of these symptoms were all higher than in those showing no signs of silicosis.

According to the Pneumoconiosis Law of Japan, patients showing values of %VC < 60%, FEV₁ % < standard value (SV, 91.79-0.373 * age)-3 * residual standard deviation (RSD, 7.19)(%), or AaDO₂ > SV (2.5 + 0.21 * age) + 3 * RSD (7.1) are considered to have marked impairment of pulmonary function.⁴ Table V shows the percentage of patients with abnormal values in each roentgenographic category. By evaluating the 3 items together, 83 (15%) of all migrant workers exposed to dust were considered to have

Table III
Total Duration of Migrant Works with Exposure to dust According to the Roentgenographic Category

	Total	Roentgenographic category of silicosis *				
		0	1	2	3	4
No. of Subjects	561 **	89	245	120	54	53
Total duration (years)						
- 9	208	62	108	24	6	9
10 - 19	136	16	68	26	16	8
20 - 29	129	5	40	44	18	22
30 - 39	64	3	22	19	8	12
40 -	24	1	8	7	6	2
Mean duration (Mean±S.D.)	16.0±11.8	7.7±8.1	14.0±11.2	20.6±11.5	22.5±11.4	21.8± 9.9

* Classified according to the Pneumoconiosis Law of Japan

** Durations of 5 migrant workers (type 1: 3, type 2: 2) are unknown

Table IV
The Prevalence Rates of Symptoms of Respiratory Disease
According to the Roentgenographic Category

	Total	Roentgenographic category of silicosis				
		PR 0	PR 1	PR 2	PR 3	PR 4
No of subjects	566 (100)*	89 (100)	248 (100)	122 (100)	54 (100)	53 (100)
Cough in the morning	212 (37.5)	23 (25.8)	80 (32.3)	57 (46.7)	26 (48.1)	28 (49.1)
Cough for 3 or more months/year	126 (22.3)	12 (13.5)	51 (20.6)	33 (27.0)	11 (20.4)	19 (35.8)
phlegm in the morning	215 (38.0)	33 (37.1)	87 (35.1)	47 (38.5)	24 (44.4)	24 (45.3)
Phlegm for 3 or more months/year	136 (24.0)	17 (19.1)	57 (23.0)	32 (26.2)	14 (25.9)	16 (30.2)
Persistent cough and phlegm for 3 or more months/year		27 (15.4)	10 (11.2)	31 (25.5)	23 (42.6)	13 (24.5)
Shortness of breath	228 (40.3)	24 (27.0)	91 (36.7)	50 (41.0)	26 (48.1)	37 (69.8)
Shortness of breath for Hugh-Janes grade 3 or over	148 (26.1)	9 (10.1)	61 (24.6)	32 (26.2)	18 (33.3)	28 (52.8)
Wheezing ^a	100 (17.7)	9 (10.1)	35 (14.2)	20 (16.5)	17 (31.5)	19 (35.8)
Attack of shortness of breath with wheezing ^a	46 (8.1)	3 (1.2)	15 (6.0)	12 (9.8)	7 (13.0)	9 (17.0)
Palpitation ^b	72 (15.1)	5 (5.7)	33 (13.6)	20 (20.6)	4 (16.0)	10 (37.0)

* Figures in brackets are percentage

a. Symptoms of 2 migrant workers are unknown (Type 1: 1; type 2: 1)

b. Symptoms of 88 migrant workers are unknown (Type 0: 2, type 1: 6, type 2: 25, type 3: 29, type 4: 26)

Table V
The Number of Migrant Workers with Exposure to Dust, Classified by the Values of the Pulmonary Function Tests According to the Pneumoconiosis Law of Japan

	Total	Roentgenographic category of silicosis				
		0	1	2	3	4
No. of subjects	561 ** (100) *	88 (100)	246 (100)	121 (100)	54 (100)	52 (100)
%VC < 80%	28 (5.0)	1 (1.1)	9 (3.7)	5 (4.1)	3 (5.6)	10 (19.2)
FEV1% < SV - 3 RSD ^a	10 (1.8)	1 (1.1)	2 (0.8)	2 (1.6)	1 (1.9)	4 (7.5)
No. of subjects	521 *** (100) *	68 (100)	232 (100)	115 (100)	54 (100)	52 (100)
AaDO ₂ > SV + 3 RSD ^b	45 (8.6)	1 (1.5)	20 (8.6)	10 (8.7)	7 (13.0)	7 (13.5)

* Figures in brackets are percentages

SV: Standard values RSD: Residual standard deviation

^a: $SV = 91.79 - 0.373 \times \text{Age} (\text{RSD} = 7.19) (\%)$

^b: $SV = 2.5 + 0.21 \times \text{Age} (\text{RSD} = 7.1) (\text{TORR})$

** Spirometry was not performed on 5 migrant workers

(type 0: 1, type 1: 2, type 2: 1, type 4: 1)

*** Arterial blood gas analyses were not performed on 45 migrant workers

(type 0: 21, type 1: 16, type 2: 7, type 4: 1)

marked impairment of pulmonary function. These consisted of 80 patients with established silicosis (20%) and 3 showing no signs of the disease (3%). According to roentgenographic categories, type I silicosis was observed in 33 patients (13%), type II in 17 (14%), type III in 10 (19%), and type IV in 20 (38%), with more patients in advanced roentgenographic categories showing more severely impaired pulmonary functions.

Of the 477 patients with silicosis, 332 had not known that they had contracted the disease and were given the diagnosis for the first time by our examination. Those patients naturally more often belonged to milder roentgenographic categories, accounting for 95% of type I and 64% of type II patients, but also for 22% and 11% of patients with more advanced type III and type IV lesions, respectively (Figure 2). Twenty to thirty percent of patients who were first diagnosed to have silicosis complained of cough, phlegm and Hugh Jones grade III or more severe dyspnea, and 12% were considered to have marked impairment of pulmonary function on the basis of the criteria of the Pneumoconiosis Law. Thus, this study showed that the disease was left undetected in many of migrant workers exposed to dust, even when they had relatively advanced roentgenographic profiles, notable subjective symptoms, or severe pulmonary dysfunction.

Status of Employment of Migrant Workers of Eastern Toyama Prefecture, Japan in Occupations Involving Dust Exposure

The status of migrant work in 566 individuals who underwent screening for silicosis is summarized in Table VI.

Thirty-four percent of them began migrant work in 1940-1944, 25% in 1950-1959, and 23% in 1930-1939. Those who began migrant work after 1960 were very few. A predominant portion of the subjects had stopped migrant work by the time of the present screening, 30% quitting in 1960-1969, another 30% after 1970, and 16% in 1950-1959. The greatest proportion of the subjects (63%) started migrant work in their teens, and 30% in their 20's. The age of stopping migrant work (those still engaged were excluded) was most frequently the 30's (26%), followed by the 40's (23%), 20's (22%), and 50's (18%). The annual duration of migrant work was most frequently 7-8 months (31%), followed by 9-10 months and 5-6 months (24% for both), and 10-11 months (21%). In eastern Toyama Prefecture, many of the migrant workers started migration during the 10 years after World War II during Japan's economic rebuilding, contributed to the high economic growth since 1960, and stopped migration rapidly just prior to the oil crisis in 1973. More than half the migrant workers engaged in tunnel construction started migrant work before they were 20 years old, many of them having become migrant workers immediately after compulsory education. Most of these workers were seasonal migrant workers, who migrated during the agricultural off-season, and only one-fifth were round-the-year migrant workers migrating for 11 months or more per year.

DISCUSSION

The percentage of migrant workers in the total working population is considered to be higher in areas where the productivity of the farming industry is lower.¹ In eastern

Toyama, 61% of migrant workers from this area had to be engaged in migrant work for pure subsistence, and only 19% did so for more than subsistence. In addition to these inherent economic circumstances, several tunnels were constructed in this region between 1920 and 1960 for the development of rivers for hydroelectric power sources. The Kurobe River flowing in the eastern part of Toyama Prefecture was

developed for hydroelectric power development programs since 1920's because of its rich water supply and steepness of the river bed. These programs, which peaked with the completion of the Fourth Kurobe River Power Plant in 1962, yielded 4 dams and 14 power plants (a total output of 800,000 kw) by 1970. The above survey of migrant workers employed in occupations involving dust exposure showed that the

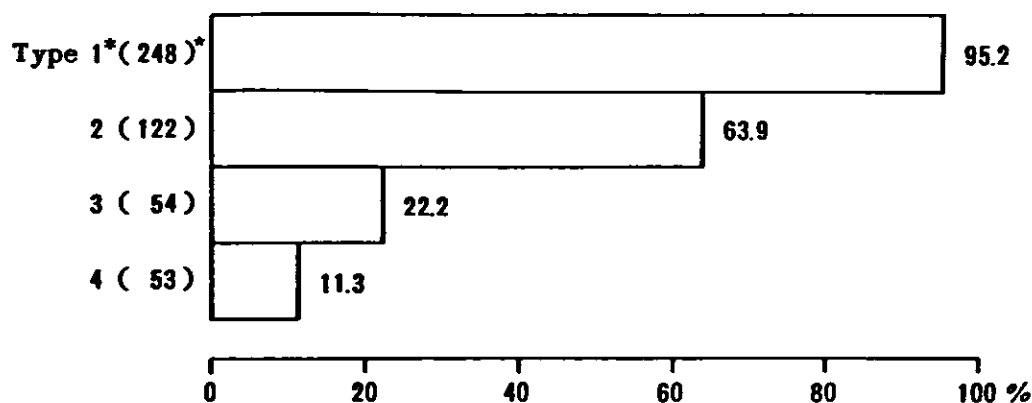

Figure 2. The rates of the silicosis patients who were first detected in the course of this research according to the roentgenographic category.

*Type 1, 2, 3, 4: Roentgenographic categories of silicosis.

*Figures in brackets are numbers of subjects.

Table VI
The Years in which Migrant Workers Began and Finished Their Jobs

	The year of finish as migrant worker						Working at this survey as migrant worker	Total
	1920	1930	1940	1950	1960	1970		
	1929	1939	1949	1959	1969	?		
The year of beginning								
1910 ~ 1919	2	1	2	4	1	1	0	11 (2.0)
1920 ~ 1929	4	6	8	7	14	20	3	62 (11.1)
1930 ~ 1939		10	20	20	20	49	9	119 (22.9)
1940 ~ 1949			10	34	69	47	29	189 (33.8)
1950 ~ 1959				25	55	30	28	138 (24.6)
1960 ~ 1969					6	14	3	23 (4.1)
1970 ~						5	4	9 (1.6)
Total	6 (1.1)	17 (3.0)	40 (7.1)	90 (16.1)	165 (29.5)	166 (29.6)	76 (13.6)	560 * (100)**

* Data are unknown for 6 migrant workers

** Figures in brackets are percentage

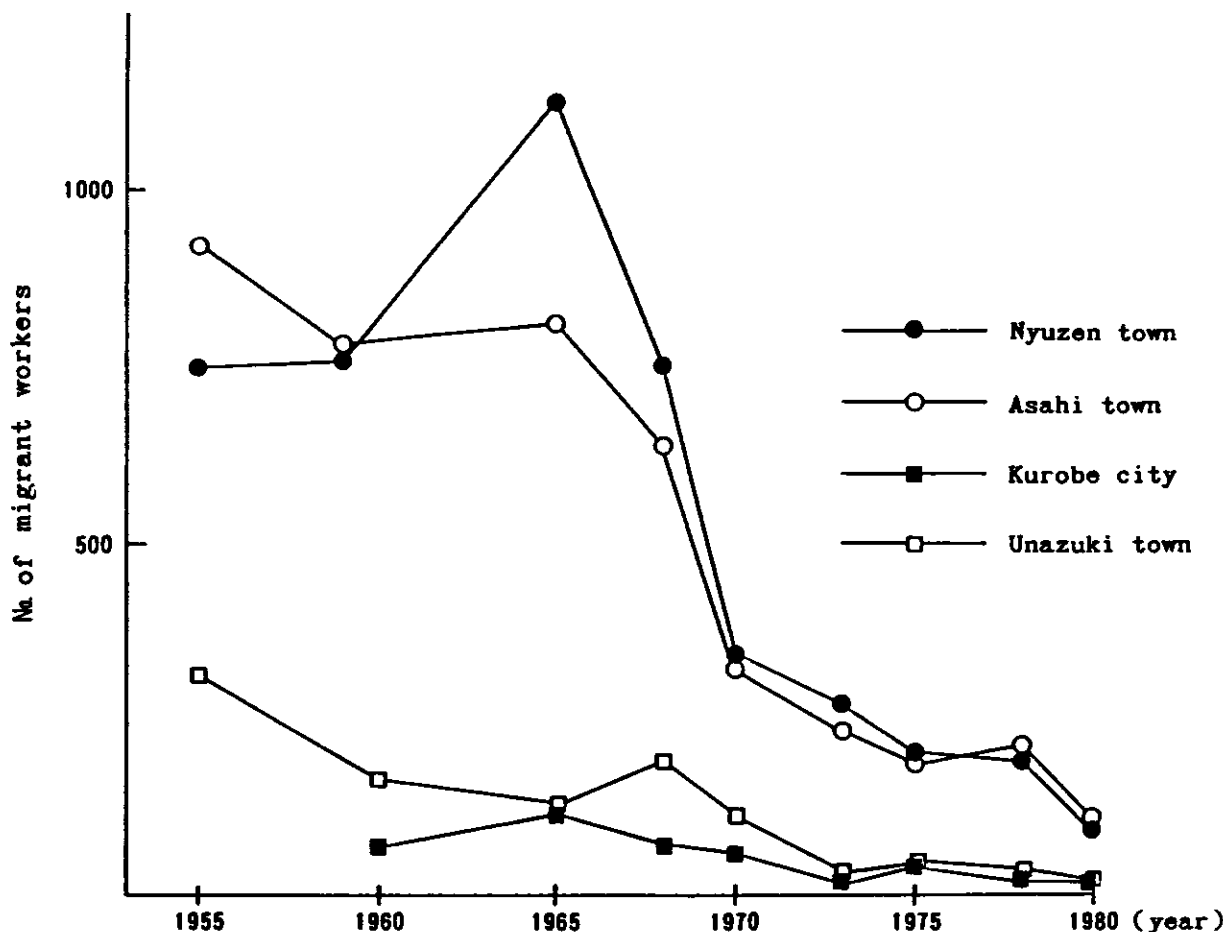

Figure 3. The number of migrant workers who had worked away from home.

(Source: Agriculture Census, Japan and Report of Fundamental Agricultural Survey of Toyama Prefecture, Japan)

number of migrant workers increased during the period of development of power sources and declined with its termination.

In eastern Toyama Prefecture, 70% of the silicosis patients had not known that they had the disease and were first diagnosed by our survey. Those who knew they had the disease at the survey had been diagnosed relatively recently (69% after 1970), and the disease was detected in many of these patients by the mass screening for tuberculosis carried out by the health center. Of the 166 patients with silicosis registered at Kurobe Health Center in 1977, when this study was started, the disease was detected in 95 (57%) by local health check-up programs rather than by examinations at work places.

In many patients, silicosis was not noted during migrant work but was first detected more than 10 years after discontinuation of the employment, first because most of them were seasonal workers not covered even by the minimum health management at the work place. The Pneumoconiosis Law of Japan requires health check-up at the beginning, during (periodic), and end of employment.⁴ However, of the migrant workers employed in occupations involving dust ex-

posure in eastern Toyama, only 60% had undergone health examinations at the work place; the percentages were lower in those in their 50's (25%) and those over 60 (10%). Migrant workers employed on monthly basis not only could seldom take periodic health check-ups (once every 3 years for those constantly exposed to dust and once every year for pneumoconiosis patients) or the examination at dismissal, which was intended for those who worked for 1 year or more, but were often excluded from the examination list. Moreover, since these workers were employed at irregular times, not many of them received the check-up at the time of employment. In addition, even after they contracted silicosis, they were not regarded as employees in operations involving dust exposure during intervals or after discontinuation of migrant work and were not covered by the follow-up programs provided by the Pneumoconiosis Law. For these reasons, migrant workers with silicosis visited medical institutions only after considerable progression of their disease and were first diagnosed. This situation lasted until 1972, when the Law of Labor Safety and Hygiene was enforced to provide free annual health check-up for those radiologically diagnosed after retirement to have type II or more advanced pneumoconiosis. However, this health check-up requires the certificate of employment at the last work place, which is

often difficult to obtain for many migrant workers employed as subcontractors and sub-sub-contractors. Furthermore, those who discontinued migrant work before the enforcement of the Pneumoconiosis Law are not covered by this law and are left unattended. As shown in Table VI, 27% of migrant workers in eastern Toyama had retired before 1960.

Secondly, the insufficient education about pneumoconiosis at the work place is considered to be a factor in the poor management of workers with the disease.^{5,6} According to our survey, 84% of the patients were aware of the risk of pneumoconiosis associated with works involving dust exposure, but only 21% received education at the work place about the possible hazard of dust exposure, and 49% obtained the knowledge from friends or by observing colleagues developing silicosis. Six percent of the patients became aware of the danger of dust exposure for the first time after they began to be treated for silicosis. Dust masks were worn by only 51% and worn consistently by one-third of them.

As mentioned earlier, migrant workers were not regarded as workers after discontinuation of migrant work and were, therefore, excluded from the coverage of labor administration. In addition, general hygienic measures were not extended to them in time, because silicosis has been considered an occupational disease. These factors contributed to the lack of recognition and neglect of a number of patients.

As observed above, the present legislation provides inade-

quate protection and management for migrant workers who engaged in occupations involving dust exposure. The 1977 amendment of the Pneumoconiosis Law, which provides for physical examinations during and after (silicosis patients) the period of employment, is still insufficient. At Kurobe Health Center, silicosis patients within its jurisdiction are registered as a major target of local health administration, and disease-control programs including annual physical assessment are executed also for those patients who had previously been excluded from public health care service, because they retired before 1960, could not obtain certificate of employment from the place of their last employment, or type I radiographic evaluation at the time of retirement.

REFERENCES

1. Yanagisawa, B.: Epidemiology on Migrant workers. *J. Jpn. Assoc Rural Med.*, 25:143-161(1977).
2. Nakagawa, H.: Pulmonary Function Impairment in Silicosis Patients Who Had Been Seasonal Labours in the East of Toyama. *Hokuriku Public Health*, 5:36-45(1978).
3. Nakagawa, H. et al.: Study on Silicosis in Migrant Workers. *J. Jpn. Assoc Rural Med.*, 30:810-817(1981).
4. Ministry of Labour: *Health Check-up Handbook for Pneumoconiosis*. Japan Industrial Safety Association, Tokyo (1978).
5. Yamazaki, Y.: Process and Factors Concerning the Frequent Occurrence of Pneumoconiosis among Migrant Workers for Tunnel Construction—Analysis of the Cases in Oita Prefecture. *Jpn.J.Public Health*, 30:336-348 (1983).
6. Une, H. et al.: Pneumoconiosis and Vibration Syndrome among Migrant workers in Kochi Prefecture. *J.Jpn. Assoc Rural Med.*, 32:969-977 (1984).

A CASE STUDY ON FIBERGLASS PNEUMOCONIOSIS WITH UNDIFFERENTIATED CANCER —FIBERGLASS, CANCEROGENOUS MATERIAL

T. SANO, M.D.

Department of Environmental and Occupational Diseases Institute for Science of Labour

Fiberglass has been used as a substitute for asbestos and its consumption has increased year after year. We know that foreign bodies, which are inhaled into tissues and remain there, can develop various types of harmful pneumoconiosis.

Since the industrial use of fiberglass started in Japan, we have warned that fiberglass should have been used under dust control; X-ray finding of this material has caused concern.

Tables I and II show sorts of substitutes, and experimental results of various substitutes.

Glassfiber, experimentation has provoked mesothelioma, Stanton et al.¹. Now, an autopsy case has been found.

A CASE STUDY ON FIBERGLASS PNEUMOCONIOSIS WITH INDIFFERENTIATED CANCER

Whether glassfiber is harmful or inert has not been determined. From the results of an autopsy case, it is shown to be "harmful."

Autopsy Record

A.S. 65 years old

Death: 1957. 3. 21 01.00

Autopsy: 1957. 2. 11 12.00—14.00

Tatsuo SANO
Hiroshi OSANAI

Skin:

dried post mortem purpura in back.

post mortem stiffen submaxilla joint.

Abdominal cavity subcutaneous, muscle tissue poor

Omentum:

hang down from stomach, partially adhere to spleen, ascites become muddy, a little; position normal

The thoracic cavity:

thymus fatty, in pericardial cavity 30 cc

yellow serosa has been found in epicardium

sinistra 5–20 cm white squad.

Pleura sinistra, dextra fibrinofibröse

Organen

Lung:

cut surface a little swollen, 2–3 mm large black nodule has been vorhanden, 2–3 mm large emphysema vorhanden (Inner side about 12 cm – 2 cm – 5 cm) in

lung area undifferentiated Cancer, intra cancer degeneration noted

Heart:

405 gr Segumentation remarkable

Liver:

1150 gr nutmeg liver

Kidney:

r 155 gr l 155 gr Rinden glomellus hyperplasia remarkable in mark fatty

Spleen:

55 gr

Diagnosis

- (1) Fiberglass Pn with undifferentiated Cancer
- (2) Cor pulmonale
- (3) Localized peritonitis
- (4) Congestion (kidney)

Causal Event

1939–1949 (11 years) Glassfiber exposure

Conclusion

Is the cancer, except Lung "I saw it naturally"

(Asbestosis like pn. by Ca compounds, *Jap. J. Ind. Health*, Vol 27 (7) 1985)

Stanton (Member of National Cancer Institute) has done an experiment on 37 sorts of substitutes of various sizes Over 0.25 μm —8 μm Mesothelioma or Sarcoma have been revealed. This Hypothesis is useful. Metaphosphat polymer has been analysed by phosphatase *in vivo* minimal reaction.

From the viewpoint of pathomorphology and pathogenesis it is not rewarding to discriminate between organic and inorganic dust. Long term inhalation of dust, organic or inorganic and its sustained deposit in alveoli can cause pneumoconiosis of various types, if the dust is insoluble, scarcely soluble or soluble.

The foreign body reaction or inflammation is the process in which the action of phagocytes and the cell proliferation containing the fibroblaste and the fibrocyte occur, resulting in cell degeneration and fibrosis of various grades. In this sense, it is reasonably concluded that the fundamental and common cause of pneumoconiosis is the inflammatory changes of the lung to excessive dusts as foreign matters.

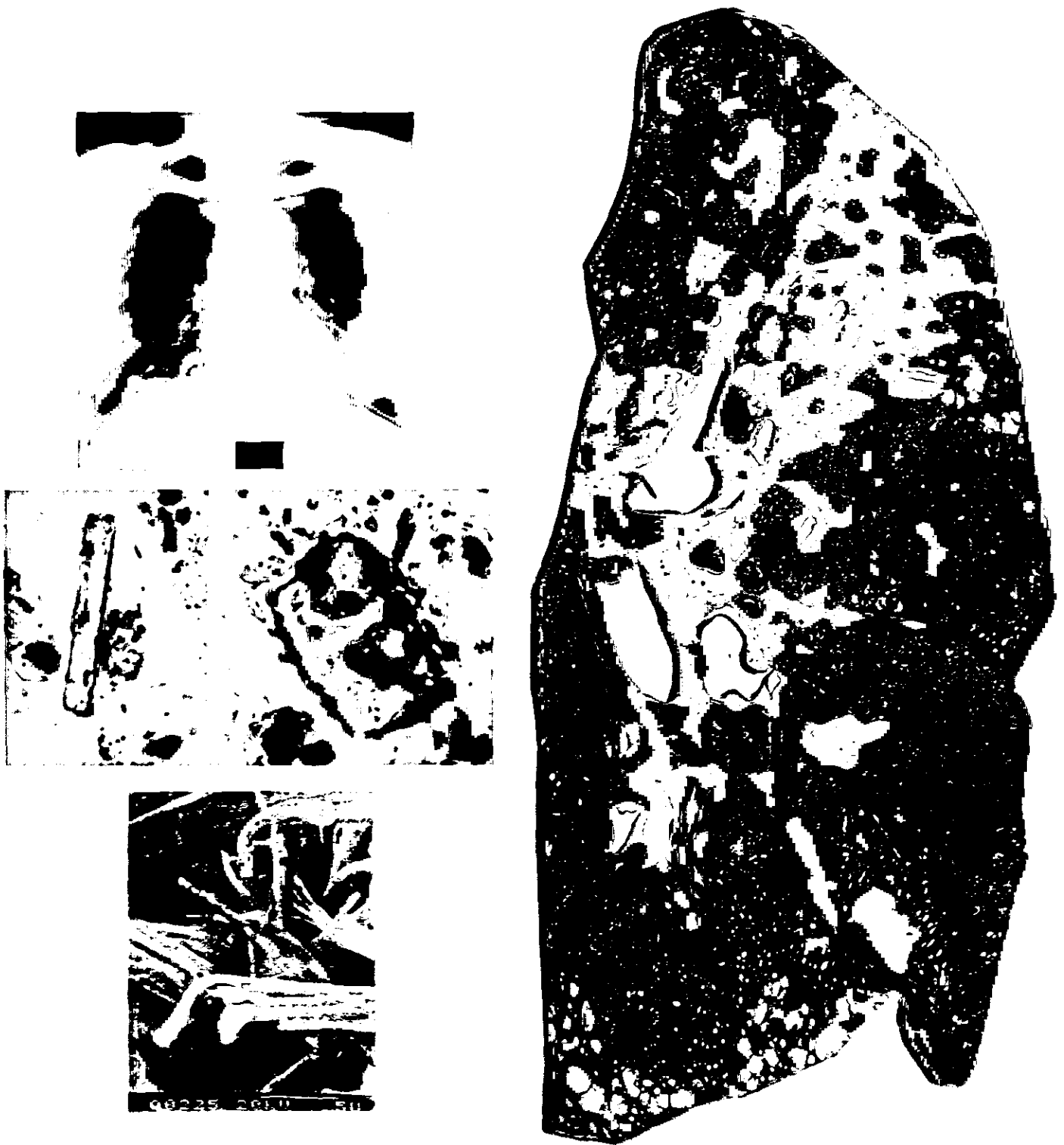

Table I
Sorts of Artificialfiber (Mineral)

Artificial Fiber (Mineral)	[Ammorphous Silicate Wisker	[Rockwool
				Glassfiber etc
				Ceramicfiber etc
		Mononuclear Wisker		K titacium
				Ca sulphate etc
		Others		Metaphosphate polymer etc
				Carbon fiber etc

Table II
Substitutes and Chief Experimental Result

Material	Methods	Animal	results	Reporter
Glass fiber	Intra thoracheal Infusion	rats	Mesothelioma	Stanton
„	„	„	„	Pott (1974)
„	„	„	„	Stanton (1977)
Ceramic fiber	„	„	„	Wagner (1973)
K titanium	„	„	Pleural sarcoma	Stanton (1978)
„	Inhalaton	Hamster	mesothelioma	Lee (1981)

Consequently, it should be concluded that every kind of dust is active and every pneumoconiosis is harmful. As Arlidge advocated, there is no inert dust and no benign pneumoconiosis.

REFERENCES

1. Stanton, M.F and Lovard, M: The carcinogenicity of fibrous materials, MBs special publication 506, *Proceedings on the Workshop on Asbestos*. 1979 pp. 143-151
2. Tatsuo, SANO and Isamu, EBIHARA: Consideration on pathology, pathogenesis, etiology and definition of pneumoconiosis. *The J. of Science of Labour* Vol. 55. No. 3 (part II). 1979 pp. 1-20
3. Isamu, EBIHARA and MASAKI, KAWAMI: Health hazards of mineral dust with special reference to the causation of immuno-pathologic system diseases: *The J. of Science of Labour*, Vol. 61. No. 12 (Part II) 1985.

ECOLOGIC ANALYSIS OF COAL WORKERS PNEUMOCONIOSIS MORTALITY IN ILLINOIS

LOUISE WIDEROFF, MSPH • Daniel O. Hryhorczuk M.D., MPH • Janel Holden Ph.D.

Cook County Hospital Division of Occupational Medicine, Chicago, Illinois, USA

INTRODUCTION

In a pneumoconioses surveillance system, states collect data on numbers of cases and calculate rates by geographical areas such as counties. Exposure data are often collected at the county level, especially when person-specific data are not available. Associations between disease and exposure at the county level can be explored through ecologic analysis. The distinguishing feature of ecologic studies is that the group (i.e., county) rather than the individual is the unit of analysis. Statistical methods employed in the analysis of such data include correlations and regression.

Ecologic designs have often been used to study diseases of unknown etiology. For example, intercounty differences in mortality from non-Hodgkin's lymphoma have been correlated with environmental and industrial exposures at the county level.¹ While the etiologies of pneumoconioses are known, ecologic studies may identify new sources of dust exposure. This study explores the ability of ecologic analysis to statistically detect an association between coal production and CWP mortality in the state of Illinois. If the technique is able to detect a known association, it may prove useful in generating new hypotheses regarding industries associated with pneumoconioses.

METHODS

All cases of CWP from 1980–1984 were identified through a review of computer tapes of Illinois death certificates. Cases were coded with International Classification of Disease (Ninth Revision) code 500 as the underlying or contributing cause of death. Five-year crude rates for white males were calculated by county. Denominators were derived from the 1980 Census and county population estimates from the non-census years, for white males age 35 and over.²

Two indices of coal mining in Illinois counties in 1965 were used as surrogate measures of exposure to coal dust.³ The first index, tons of coal mined, was a direct measure of production. The second index, the average tons of coal mined per worker per 8-hour day, was a measure of mine productivity. These two indices were further subdivided into underground, surface and total coal mining. Exposure data from 1965 were selected to allow for a 15 to 20 year lag period between first exposure and death.

The association between CWP mortality and coal mining was analyzed using weighted least-squares regression. Six different univariate regression models were fitted to the data.

Counties with both zero death and zero production were excluded from each of these analyses. Rates were log-transformed and weighted by the inverse of the square roots of the denominators, in order to meet the assumptions of regression analysis. The SAS Regression Procedure program was used to perform the analysis.⁴

RESULTS

There were 367 white male CWP deaths from 1980 to 1984, 7 deaths among black males and 1 among white females. Mortality rates ranged from zero in 61 counties to 322.4/100,000/5 years in Franklin County, with a state average of 3.7/100,000/5 years. Forty-six out of a total 102 Illinois counties met the study criteria of having either CWP mortality in 1980–1984 or coal production in 1965. Forty-one of these counties reported CWP deaths and 5 produced coal but reported no CWP deaths.

Seven counties had underground but no surface mining, 9 had surface but no underground mining, 6 had both types and 24 had neither. Non-zero values for 1965 underground coal production ranged from 16,731 tons in Henry County to 6,182,282 tons in Franklin County, with a state mean of 1,766,958 tons for coal producing counties. Non-zero surface production ranged from 1,938 tons in Johnson County to 8,220,858 tons in Fulton County, with a state mean of 1,047,647 tons. Underground mine productivity in tons/worker/day was highest in Franklin County (23.0) and lowest in Henry County (9.1) with a mean of 18.1 for coal-producing counties. Surface mine productivity was highest in Knox County (56.1) and lowest in Gallatin County (14.2) with a state mean of 34.3 tons/worker/day.

Table I presents the results of linear regressions of the exposure indices on the log of CWP mortality rates. CWP mortality was significantly ($p \geq .005$) associated with tons of underground, surface and total production. In the underground models, production explained 51% of the variability in CWP mortality rates, while in surface models, production explained 18%. Corresponding values were lower with productivity as the surrogate exposure variable: 22% for underground tons/worker/day and 9% for surface tons/worker/day. The associations between underground, surface and total tons/worker/day and CWP mortality were also statistically significant ($p \geq .05$).

In Figure 1, the CWP mortality rates are plotted on a log scale against the 1965 underground tons produced. Franklin County stands out as having the highest CWP mortality and

Table I
Linear Regression of Log CWP Mortality Rates on Selected
Measures of Coal Mine Production in Illinois

Variable	B ₀	B ₁	p	r ²
Underground				
Tons	1.036	7.223 x 10 ⁻⁷	.0001	.51
Tons/worker/day	1.084	6.790 x 10 ⁻⁵	.0016	.22
Surface				
Tons	1.122	3.497 x 10 ⁻⁷	.0032	.18
Tons/worker/day	1.124	2.100 x 10 ⁻⁵	.0498	.09
Total				
Tons	0.879	4.492 x 10 ⁻⁷	.0001	.55
Tons/worker/day	0.992	2.340 x 10 ⁻⁵	.0041	.17

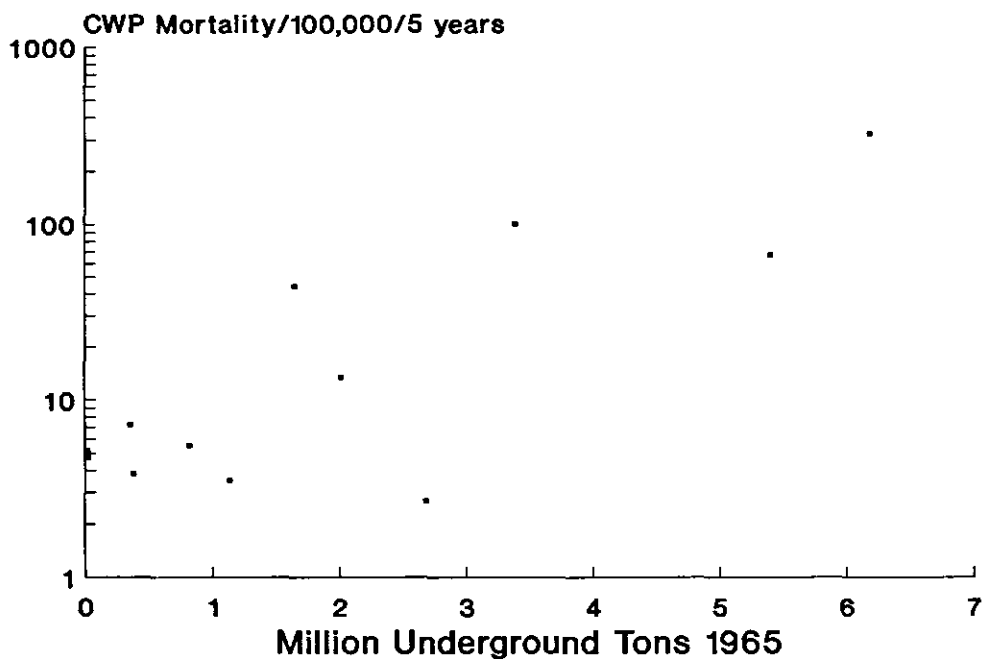

Figure 1. CWP mortality by 1965 underground tons.

1965 underground mine production. Other notable characteristics of Franklin County are that it had the highest cumulative coal production of all Illinois counties from 1882 to 1965, and all its mines are underground.³

DISCUSSION

This study demonstrates that ecologic analysis is able to detect the known association between CWP mortality and exposure to coal dust in underground mines. As expected, CWP mortality was more strongly associated with underground mining than surface mining. The significant association of surface mining and CWP mortality may be due to the concurrence of surface and underground mining in counties of high production and high CWP mortality. For example, Williamson County, which had the second highest mortality rate in the state (100.3/100,000/5 years), produced more than 3 million tons in surface mines and more than 3 million tons in underground mines in 1965.

While surface mining was statistically associated with CWP mortality, we cannot determine whether any individual death was a result of exposure in surface mines without obtaining individual work histories. Inferences about individuals drawn from data on groups are susceptible to the "ecologic fallacy."⁵

A commonly used measure of dust exposure is the product of the dust concentration and duration of exposure. Surrogate exposure measures used in ecologic studies should be close approximations of the workers cumulative dust exposure. The type of data available at the county level often determines what surrogate variables will be used in an analysis, and conceivably, a disease-exposure association may be missed when a poor surrogate variable is selected. In this study, county coal production and mine productivity were both significantly associated with CWP mortality. Productivity, however, was a poorer predictor of mortality than actual production in underground, surface and total mining models. One possible explanation for this result is that high productivity by definition reflects high production relative to person-work time. Decreased person-work time may mean less exposure to coal dust and thus lower CWP mortality rates.

Several biases may be present in this study. Measurement bias may result from the use of cross-sectional exposure data

from just one year, since that year could be atypical for coal production in any given county. Age confounding may occur because rates are not age-adjusted. We did not have access to national multiple-cause CWP mortality rates, and rates based solely on underlying cause would have missed 72% of all CWP deaths in Illinois. Another potential confounder, intercounty migration from mining to non-mining areas, would weaken the association between coal mining and CWP mortality. Migration may also occur from one type of mining to another, both within and between counties, although the effects of this are more difficult to predict. Other unmeasured variables which may confound or modify the disease-exposure relationship include mining techniques (i.e., longwall vs. panel) and dust control.

A major advantage of ecologic studies is that they do not require primary data collection but may rely instead on pre-existing sources of data. For ecologic studies to be feasible, there must be a sufficient number of disease events at the group level, as well as suitable exposure data. For example, Illinois was the fifth highest coal-producing state in the U.S. as of 1984, and has the largest bituminous coal resources in the country. Thus, Illinois has incurred substantial CWP morbidity and mortality, and data on coal production is easily obtained.

As an adjunct to simple geographic mapping, ecologic analysis is useful for identifying predictor variables of CWP mortality in Illinois. In addition to examining the data cross-sectionally, CWP mortality trends can be studied through time-series analysis in future research. Ecologic analysis may prove useful in identifying predictor variables of disease outcomes for other pneumoconioses.

REFERENCES

1. Cantor, K., Fraumeni, J.: Distribution of Non-Hodgkin's Lymphoma in the United States. *Cancer Res.* 40:2645-2652 (1980).
2. *County Estimates by Age, Sex and Race Prepared for the National Cancer Institute.* Population Estimates Branch, Population Division, Bureau of the Census. Washington, D.C. (1987).
3. *Eighty-fourth Coal Report of Illinois.* Illinois Dept. of Mines and Minerals Annual Coal, Oil and Gas Report. Springfield (1965).
4. *SAS User's Guide: Statistics.* Version 5 Ed. SAS Institute Inc. Cary (1985).
5. Morgenstern, H.: Uses of Ecologic Analysis in Epidemiologic Research. *Am. J. Public Health.* 72:1336-1344 (1982).

DEATH CERTIFICATE-BASED SURVEILLANCE OF SILICOSIS AND ASBESTOSIS IN ILLINOIS

LOUISE WIDEROFF, MSPH • Daniel O. Hryhorczuk, M.D., MPH
• Anne Krantz, M.D., MPH, • Janet Holden, Ph.D.

Cook County Hospital Division of Occupational Medicine, Chicago, Illinois, USA

INTRODUCTION

Surveillance is fundamental to the prevention and control of pneumoconioses. In the U.S., pneumoconiosis reporting systems have been proposed and also piloted by several state health departments.^{1,2} The pneumoconioses are considered good target diseases for nascent occupational disease surveillance systems because they are of known etiologies, are almost always related to workplace exposures, are relatively easy to diagnose, and are preventable.

Sources of data in occupational disease surveillance include workplace surveys, laboratory logs, hospital discharge records, employee health records, disability files, physician reports and death certificates.^{3,4} Death certificates are limited by inaccuracies in diagnosis and certification of the cause of death, and by misclassification of the decedent's occupation. They are not early indicators of outbreaks for diseases of long latency or duration and are not suitable for studying nonfatal conditions.⁵

Nevertheless, death certificates are a vast and easily accessed data source. Other states have used them to quantify pneumoconiosis mortality and to describe the demographic and geographic distribution of cases.⁶ Follow-back investigations of cases may lead to the detection of exposure sites. This study explores the usefulness of death certificates as a surveillance tool for silicosis and asbestosis in the state of Illinois.

METHODS

Computerized death records from the Illinois Department of Public Health were obtained for the years 1969 to 1984. Cases were identified by International Classification of Disease (ICD) codes 5150 and 5152 of the eighth Revision, and codes 501 and 502 of the Ninth. The study diseases were coded as the underlying or contributing cause of death, although prior to 1979, four-digit codes precluded the differentiation of the pneumoconioses as contributing causes on Illinois death tapes. Additional variables abstracted from the tapes were sex, race, age and year of death, and the geographical subunit county of residence.

Crude state and county-specific mortality rates were calculated by year and also for the five-year period 1980–1984. The calculation of rates was limited to white males because of sparse data for other sex-race groups. Population estimates were used in the denominators for all

years except 1980, when census data were available.^{7,8} Denominators included individuals age 35 and over, since persons below this age were not believed to be at risk of pneumoconiosis mortality.

Correlations between observed geographical patterns of mortality and associated industries were explored. An annual statewide manufacturer's directory was used to identify asbestos products plants in the counties where asbestosis cases resided.⁹ Silicosis death rates were superimposed on maps showing the location of industries and mineral deposits associated with silica dust exposure.¹⁰ The industrial data spanned a period of thirty years to account for past exposures and to ascertain the current status of specific worksites and industries.

RESULTS

There were 76 silicosis cases reported by underlying and contributing cause of death from 1979–1984 (ICD-9). White males constituted 78% of the total, black males 20% and white females 2%. The mean age of death was 68 years with a range of 28 to 89 years. An additional 55 silicosis cases were identified by underlying cause of death from 1969 to 1978 (ICD-8). Of these, 87% were white males, 11% black males and 2% white females. Their mean age of death was 69 years and the range was 34 to 88 years.

The five-year state silicosis mortality rate for white males, which included underlying and contributing causes of death in the numerator, was 0.5/100,000. A rate of 40.2/100,000/5 years—based on 4 deaths in the numerator—was found in Alexander County, at the southwestern tip of Illinois. In Figure 1, the five-year rates overlay a section of a map showing siliceous mineral deposits in this area. In addition to a crude rate over 40 times the state rate, Alexander County cases died at an average age which was 13 years younger than the mean for Illinois white male silicotics (57.2 vs. 70.5 years).

For white males throughout Illinois, silicosis was more likely to be listed as an underlying rather than contributing cause of death in younger cases. Of the 22 who died younger than 70.5 years of age, 14 (64%) had silicosis certified as the underlying cause, compared to 18 out of 37 (49%) in the 70.5 or above age group.

There were 53 asbestosis cases reported during the ICD-9 period from 1979 to 1984, of which 83% were white males,

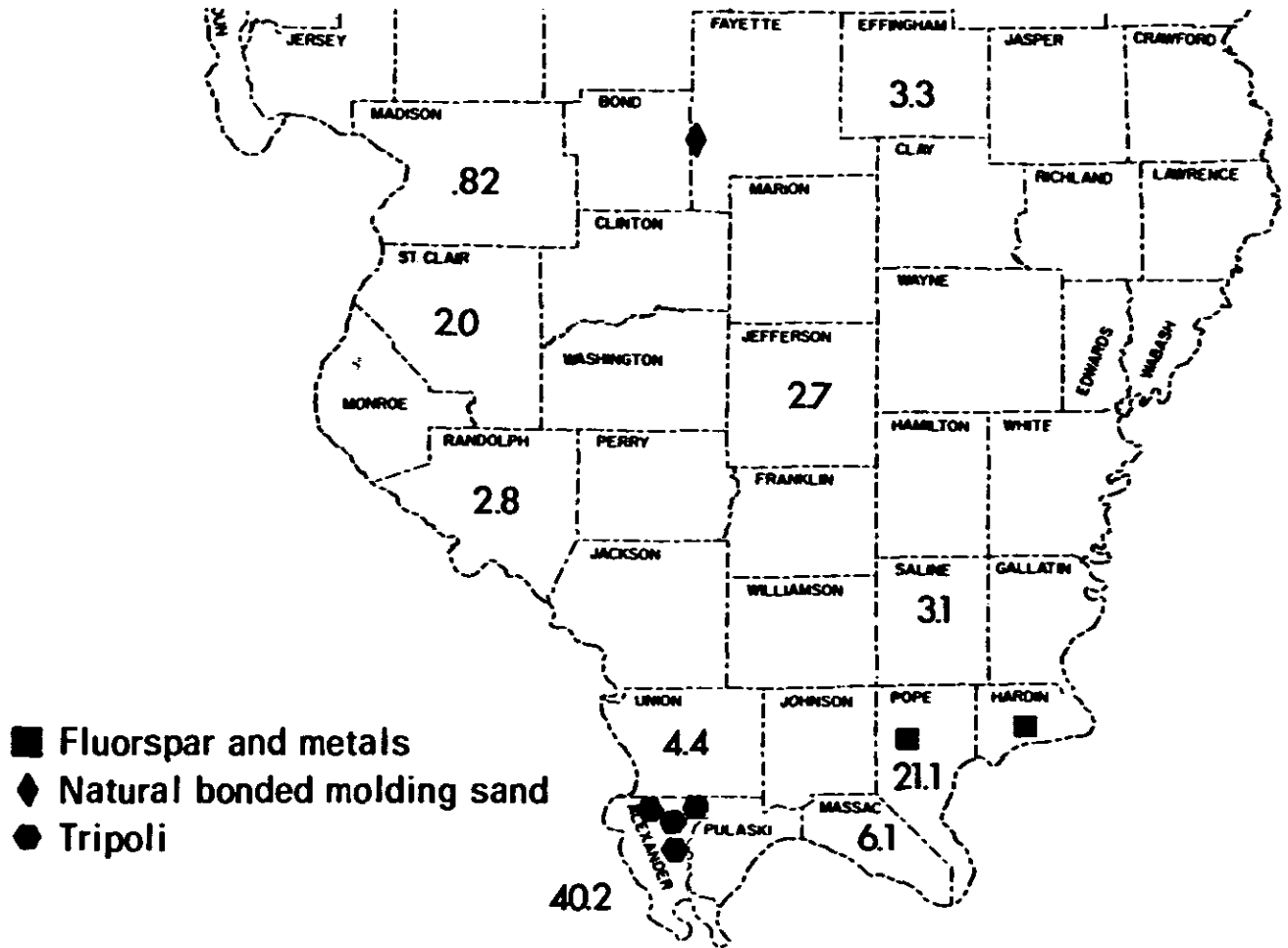

Figure 1. Siliceous mineral deposits and five-year silicosis mortality in southern Illinois.

6% black males and 11% white females. The mean age of death was 66 years and cases ranged from 44 to 84 years. There were 22 cases during the ICD-8 period from 1969–1978 with asbestosis coded as the underlying cause of death. White males were 77% of the total, black males 5% and white females 18%. The mean age was 63 years, with a range of 42 to 81 years.

The Illinois asbestosis mortality rate for white males was 0.41/100,000 per 5 years. Asbestosis deaths were reported in 11 out of 102 Illinois counties, 4 of which consistently had annual rates above zero: Cook, Lake, McLean and Madison. The five-year rates per 100,000 in these counties were 0.28, 3.0, 6.1 and 1.2, respectively.

DISCUSSION

The results of this study demonstrate that death certificate-based surveillance in Illinois is useful for identifying point sources of exposure in areas where pneumoconiosis deaths occur. The extraordinarily high silicosis mortality rates in Alexander County are a striking example of this.

As the map in Figure 1 indicates, Alexander County is a center of tripoli production, a mineral from which microcrystalline silica is obtained for use as a filler and abrasive. Two tripoli mines and mills were surveyed by the National Institute for Occupational Safety and Health in 1979, following six years of high dust levels in air sampled by the Mine Safety and Health Administration. The survey documents simple silicosis in 26% of the 61 participants and progressive massive fibrosis in 11%.¹¹ The mean duration of exposure for the former group was 7.7 years with a 1–9 year range, and 7.1 years for the latter, with a range of 2.5–14 years.

Our study reviewed Illinois death certificate data back to 1969. The first death we identified in Alexander County occurred in 1969, 10 years prior to the morbidity survey. Five more deaths with silicosis as the underlying cause occurred in Alexander and adjacent counties before the survey. Thus, an annual review of Illinois death records would have alerted authorities to this serious outbreak years earlier. Prompt intervention to correct exposures could have reduced the number of Illinois workers dying from pneumoconiosis.

Probable point sources of asbestos exposure were identified in the four counties with high concentrations of asbestosis deaths. In the 1955 edition of the manufacturer's directory, Cook County listed nine asbestos products plants employing about 2500 workers. Lake County had one major plant with 2200 workers and McLean had a single plant with 200. Madison County listed a small asbestos products plant in the 1965 edition. Possible asbestos containing products plants were located in these counties as well. As of 1987, only one of the identified plants was still listed and not as an asbestos products operation.

Cases who died at an early age may be indicative of recent high exposures. We were surprised that silica dust exposures severe enough to result in early death were still occurring, as evidenced by 3 cases of black males who died at ages 28, 33 and 34 between 1974 and 1980. This indicates that in the calculation of silicosis mortality rates, the 35-year cutoff in the denominators may not always be applicable. Another aspect of our rates is that they are not age-adjusted to the U.S. population, since national age specific pneumoconiosis mortality rates based on multiple causes of death are not readily available. It is unlikely that large differences in crude rates, such as those seen in this study, can be attributed to the confounding effects of age.

Death certificates have proven to be an important component of pneumoconiosis surveillance in Illinois. We have identified Illinois counties of high risk for silicosis and asbestosis mortality together with potential point sources of exposure. Follow-back studies are now underway to verify exposures on a case-by-case basis. While mortality is not generally a timely surveillance measure for the pneumo-

conioses, the experience in Alexander County demonstrates that death certificates can be used to detect outbreaks that result in high mortality or early death. The clustering of cases over time in a given geographical area, and an age of death markedly below the mean would clearly be cause for further investigation.

REFERENCES

1. Mullan, R.J.: A Proposal for State-Based Reporting of the Pneumoconioses and Mesothelioma. *Conference of State and Territorial Epidemiologists*. Center for Disease Control, Minneapolis, Mn. (June, 1984).
2. Baker, E.: *Comprehensive Plan for Surveillance of Occupational Illness and Injury in the United States*. National Institute for Occupational Safety and Health, Centers for Disease Control. Atlanta (1986).
3. Mullan, R.J.: Options for State-Based Reporting of Occupational Diseases. *Conference of State and Territorial Epidemiologists*. Center for Disease Control, Madison, Wi. (June, 1985).
4. Halperin, W., Frazier, T.: Surveillance for the Effects of Workplace Exposure. *Ann. Rev. Public Health*. 6:419-432 (1985).
5. Dubrow, R., Sestito, J., Lalich, N., Burnett, C., Salg, J.: Death Certificate-Based Occupational Mortality Surveillance in the United States. *Am. J. Ind. Med.* 11:329-342 (1987).
6. Schwartz, E.: Use of Death Certificates for Surveillance of Work-Related Illnesses-New Hampshire. *MMWR* 35:537-540 (1986).
7. *County Estimates by Age, Sex and Race Prepared for the National Cancer Institute*. Populations Estimates Branch, Population Division, Bureau of the Census. Washington D.C. (1987).
8. *Illinois Population Estimates*. Div. of Health Information and Evaluation, Illinois Dept. of Public Health. Springfield (1981-1984).
9. *State Industrial Directory*. 1955, 1965, 1987 Eds. Illinois Manufacturers' News, Inc. Chicago (1955, 1965, 1987).
10. Malhotra, R., Smith, P.: *Directory of Illinois Mineral Producers, 1974*. Illinois State Geological Survey IMN 64. Urbana (1976).
11. Banks, D., Morring, K., Boehlecke, B., Althouse, R., Merchant, J.: Silicosis in Silica Flour Workers. *Am. Rev. Respir. Dis.* 124:445-450 (1981).

GALLIUM-67 EMISSION TOMOGRAPHY IN ASBESTOSIS

E. M. CORDASCO, M.D. • J. K. O'Donnell, M.D. • D. H. I. FEIGLIN, M.D.
• R. T. GO, M.D. • L. Gonzalez, M.D. • W. J. MacIntyre, Ph.D.

The Cleveland Clinic Foundation, Cleveland, Ohio, USA

ABSTRACT

Asbestosis and interstitial collagen vascular lung diseases are characterized by a combination of alveolitis and fibrosis with an early alveolitis/or bronchiolar component usually preceding the fibrotic stage. The severity of alveolitis is not well documented by chest X-ray or pulmonary function testing except for the abnormal diffusion capacity being a relatively early manifestation. Imaging with gallium-67 is useful in delineating the inflammatory component of interstitial lung disease but mild diffuse disease may escape detection. To determine the added advantage of emission tomography (SPECT) we have studied 31 asbestosis patients with both planar and SPECT methods. Planar images of 500k counts were acquired 48 hours after injection of 6010 mCi Gallium-67 Citrate. SPECT involved 64 views of the thorax over a 360 transaxial rotation. Reconstruction provided image slices in multiple body planes. Abnormal pulmonary Gallium-67 Citrate activity was present in 20/31 planar scans (65%) and in 27/31 (87%) SPECT studies compared to our established normals. Planar abnormalities were randomly patchy while SPECT imaging showed predominant lower lobe involvement SPECT correlated well with clinical disease estimates, less so with Pulmonary Function Tests (Diffusing Capacity), and poorly with chest X-ray findings. SPECT documents more accurately and earlier the alveolitis component of asbestosis. This may be beneficial in evaluating further experimental chemoprevention treatment programs utilizing the retinoid compounds.

No Paper provided.

PULMONARY FIBROSIS CAUSED BY SYNTHETIC TEXTILE FIBRES?

GUNNAR HILLERDAL,* M.D. • Lena Steinholtz,† M.D.
Leif Rosenhall,‡ M.D. • Anders Lindgren,§ M.D.

*Department of Lung Medicine, University Hospital, Uppsala

†County Hospital, Västerås

‡University Hospital, Umeå

§Department of Pathology, University Hospital, Uppsala, Sweden

INTRODUCTION

In 1975, Pimentel et al.¹ described respiratory disease caused by synthetic textile fibres. Since then, to the authors' knowledge, no further reports on this have been published. We have now seen three patients with pulmonary fibrosis, probably due to this cause.

PATIENTS

Case 1. A 52-year old woman was referred because of pulmonary infiltrates on her chest X-ray and a dry cough combined with increasing dyspnoea. She had previously been

healthy and had never smoked. Chest X-ray showed a reticular pattern with some confluent areas in the upper lobes (Figure 1). The tuberculin test was negative, as were tests for auto-antibodies of various kinds. Routine blood tests, including erythrocyte sedimentation rate, were completely normal.

The patient started working in a textile shop fifteen years before admission. She measured and cut cloth that was mainly synthetic (acrylic fabrics, polyesters, imitation leather etc) and occasionally also glass fibre, but she was not otherwise exposed to silica or other dust. The work was very dusty.



Figure 1. (Case 1). Diffuse pulmonary fibrosis, more marked apically and at the periphery.

In the first years the patients was only slightly irritated by this dust, but she then developed an irritating dry cough which was much worse in the afternoons of working days. After 12 years she had to stop, as she found it too disturbing. She also noticed that during weekends and prolonged absence from work, she was very much better, and was not bothered by perfumes and other very strong smells which on weekdays gave her coughing attacks.

Pulmonary function tests showed lung volumes within low normal values. The compliance was abnormal and the elastic recoil remarkably high (max 45 cm H₂O). The nitrogen washout curve was abnormal, with a steep alveolar plateau. A needle biopsy (Tru-Cut[®]) of the right lung showed a late stage of interstitial fibrosis with considerable alveolar thickening (Figure 2). In polarized light, there were multiple small foreign bodies within the fibrotic areas.

The patient has been followed for seven years after the biopsy. She was awarded workmens compensation and retired from her work. There has been a slow progression of her fibrosis with an increasing dyspnoea, despite the fact that she is no longer in contact with textile dust.

Case 2. A 66-year old woman was seen because of dyspnoea and pulmonary infiltrates on chest X-ray (Figure 3). 40 years

earlier she started working in a textile shop with very similar working conditions as case 1. Routine blood tests were normal. Lung function test showed a slight restrictive disease. Bronchoscopy revealed small hyperplastic infiltrates in many places in the bronchial tree. Biopsy showed granulation tissue, histiocytes, multinuclear giant cells, and foreign bodies which looked like small fibres. The changes were diagnosed as inflammation due to foreign body inhalation.

Case 3. A 47-year old woman presented with bilateral pulmonary fibrosis clinically and radiologically. She had a restrictive lung disease with a lung function about 75% of predicted. Like the former two patients, this patient had been working with textiles and particularly with synthetic textiles, which she had cut and measured. An open lung biopsy revealed the same type of change as in case 1 with diffuse pulmonary fibrosis, foreign body granulomas and foreign bodies.

DISCUSSION

The histories of the patients strongly suggest that the pulmonary fibrosis was caused by the exposure to synthetic fibres, and this is supported by the biopsies. Unfortunately, as the foreign bodies were in minuscule pieces, it was not possible to analyze them. Glass fibres are unlikely to reach

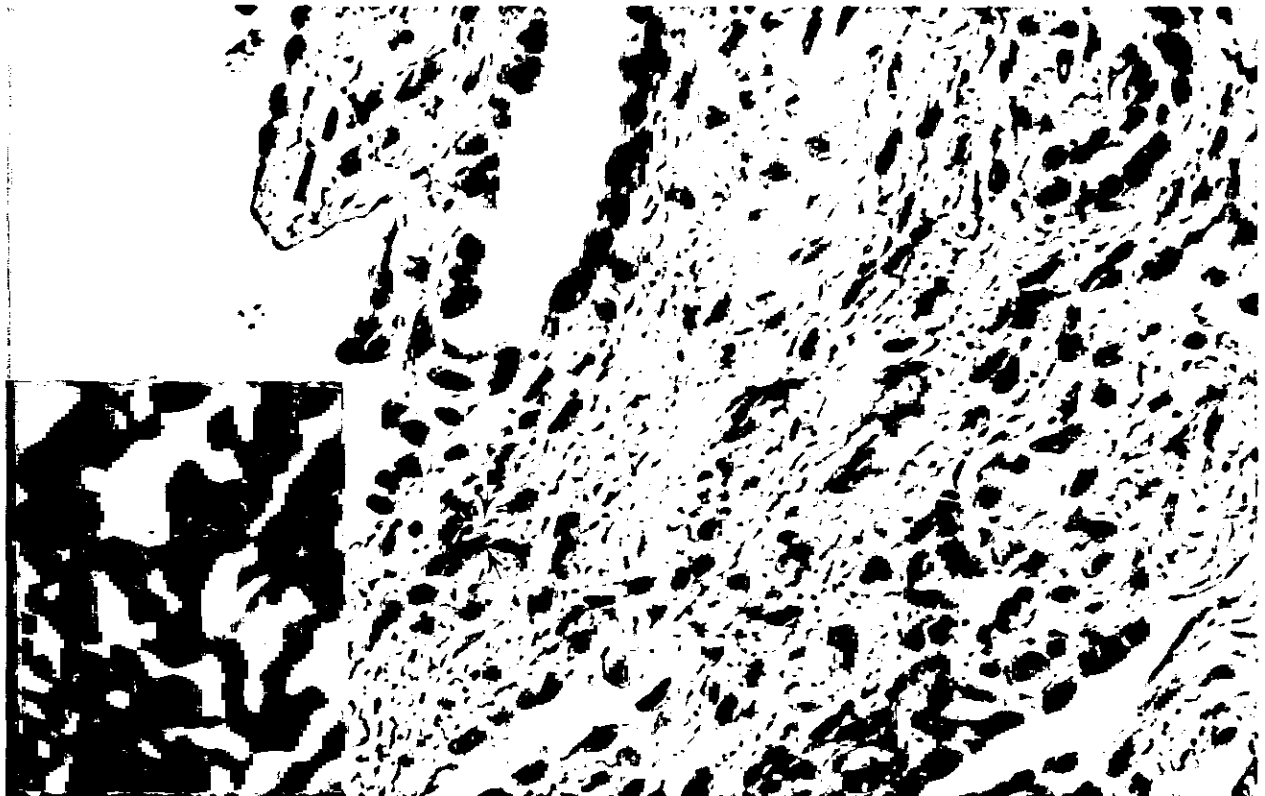

Figure 2. (Case 1). Lung biopsy. Interstitial fibrosis with marked thickening of alveolar septa. A macrophage (arrows and inserted detail) contains birefringent foreign material.

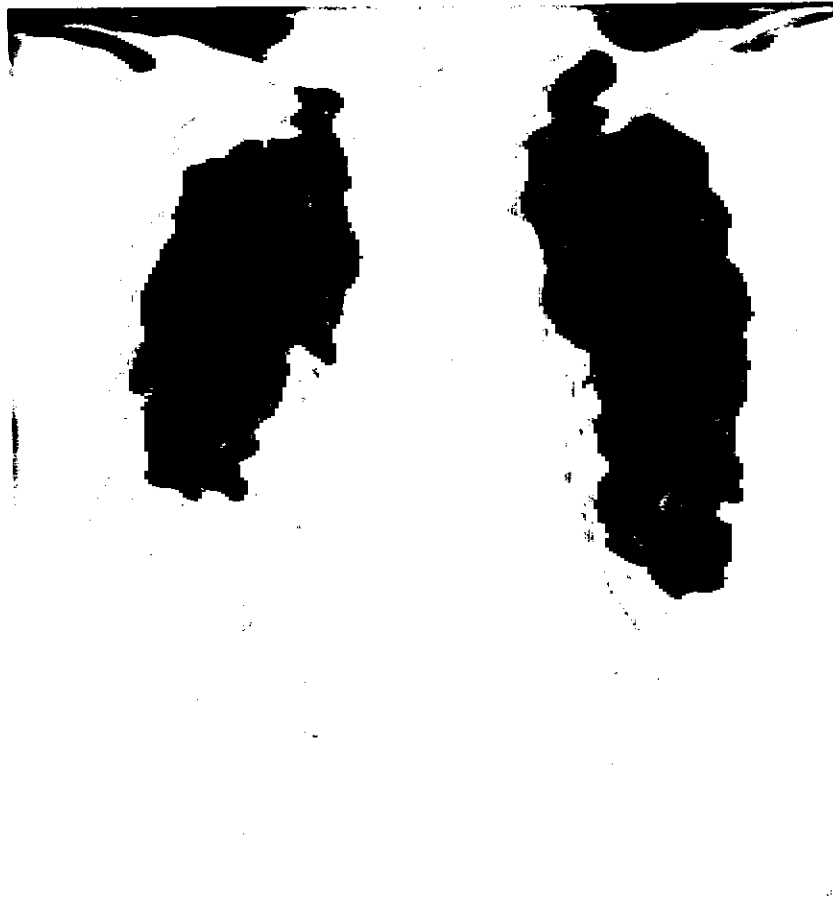

Figure 3. (Case 2). Pulmonary fibrosis.

the alveoli because of their size, and no fibrogenic effect of these fibres in humans has been described. We believe that the small foreign bodies were in fact small pieces of synthetic fibres, but so far this remains unproven.

Synthetic textile fibres consist of a number of different substances. Some of them are polyesters which are difficult to degrade biologically. The lung disease radiologically and microscopically is very similar to that described from polyvinyl chloride.^{2,3} This type of agent is also very resistant to biological degradation, and it is quite possible that inhaled small particles of this type, with a great resistance against biological enzymes, in selected patients can cause in-

flammatory reactions of foreign body type, leading to pulmonary fibrosis.

Thus, synthetic fibres seem to be one more possible cause for pulmonary fibrosis. No doubt, there are many other exogenous agents that can also be fibrogenic when inhaled, and a thorough occupational history of any patient with "idiopathic" pulmonary fibrosis is mandatory.

REFERENCE

1. Pimentel, J.C., Avila, R., Lorenzo, A.G.: Respiratory disease caused by synthetic fibres: a new occupational disease. *Thorax* 30:204-219 (1975).

THE DISTRIBUTION OF LYMPHOCYTES AND LYMPHOCYTE PHENOTYPE SUGGESTS SILICO-PROTEINOSIS IS NOT A SYSTEMIC DISEASE

D. E. BANKS, M.D. • J. E. Morgan, Ph.D • Y. Y. Hammad, D.Sc.

Sections of Pulmonary Diseases & Allergy and Clinical Immunology
Tulane University School of Medicine, New Orleans, Louisiana 70112, USA

ABSTRACT

In order to study the immunologic features of silico-proteinosis, we produced this illness in specific pathogen free Fisher 344 rats by providing an exposure of 10 mg/m³ of free crystalline silica for 3 months (6 hrs./day, 5 days/wk.). Cell suspensions from minced spleen and collagenase-digested lung of the silica-exposed and non-exposed rats were assessed for differences (mean \pm S.E.M.) in total cells and lymphocytes recovered, as well as lymphocyte subpopulations, using FTIC-conjugated monoclonal antibodies and flow cytometry.

The total cells recovered ($\times 10^6$) from the minced spleen of silica exposed (n=5) and non-exposed (n=5) rats were not significantly different (146 ± 19 v. 173 ± 50). Neither was there a significant difference in lymphocyte subpopulations distribution (% T helper [31 ± 3 v. 27 ± 2], % T non-helper [18 ± 3 v. 16 ± 2], T helper:non-helper ratio [1.8 ± 0.1 v. 1.8 ± 0.1], and % B cells [46 ± 4 v. 53 ± 2]) in the silica and non-exposed rats, respectively.

In the collagenase-digested lungs of silica exposed (n=5) and non-exposed (n=5) rats, total cells ($\times 10^6$) (37 ± 8 v. 28 ± 6), total lymphocytes ($\times 10^6$) (18 ± 4 v. 18 ± 2), % B cells (21 ± 1 v. 27 ± 3), and T helper:non-helper ratio (1.0 ± 0.3 v. 0.65 ± 0.1) were not significantly different. The % lymphocytes (50 ± 2 v. 79 ± 4), % T helper (17 ± 1 v. 28 ± 2), and % T non-helper (20 ± 3 v. 44 ± 3) in silica-exposed and non-exposed, respectively, were significantly different.

Systemic alterations in lymphocyte number and subpopulations were not apparent in the rats with silico-proteinosis. Abnormalities in the number and distribution of lymphocytes appear localized to the lung.

No Paper provided.

COMPUTED RADIOGRAPHY UTILIZING SCANNING LASER STIMULATED LUMINESCENCE AND ITS APPLICATION FOR CLASSIFICATION OF PNEUMOCONIOSES

NOBUYOSHI NAKAJIMA • M. Ishida • H. Kato • • M. Takano

Development Center, Miyanodai, Fuji Photo Film Co., Ltd., Kanagawa 258, JAPAN

BASIC CONFIGURATION OF THE CR SYSTEM

A new computed radiographic system based on new concepts and the latest computer technologies has been developed. The system eliminates the drawbacks of conventional radiography by combining digital image processing and the Imaging Plate as an X-ray sensor.¹

Figure 1 shows a basic block diagram of the system which is called Fuji Computed Radiography (FCR). The Computed Radiography (CR) system consists of five major units:

1. X-ray image sensor which temporarily stores the X-ray energy pattern. It is called "Imaging Plate" in this system.
2. Image reader which converts the latent image on the Imaging Plate into digital time-series signals.

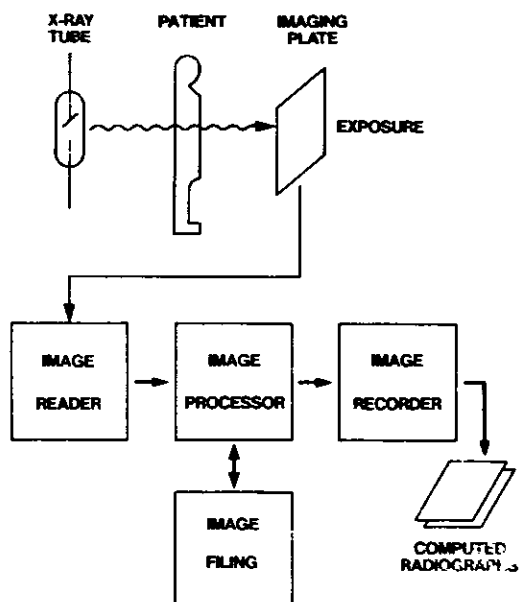

Figure 1. Basic block diagram of the CR system.

3. Image processor which manipulates the image digitally to provide radiographs the high diagnostic quality.
4. Image recorder which records the processed signals on film by scanning laser beam.
4. Image recorder which records the processed signals on film by scanning laser beam.
5. Image filing which has made it possible to store radiographic image digitally by use of reversible or irreversible data compression technique.

The basic principle of the CR system is illustrated in Figure 2. "Imaging Plate (IP)" is a flexible plate of 1mm or less thickness coated with fine photostimulable phosphor crystals using an organic binder. It can be used to obtain radiographs in exactly the same way as screen-film combination is used in conventional radiography.

After the X-ray image is stored on the Imaging Plate, it is scanned with the helium-neon laser beam to produce the photo-stimulable luminescence radiation.² The laser beam is deflected by a scanning mirror while the Imaging Plate is traversed to form an orthogonal scan. The luminescence radiation is collected through a light guide into photomultiplier tube and it is converted into electrical signals. This mechanism is called "Scanning-Laser-Stimulated-Luminescence." The Imaging Plate can be used repeatedly after erasing the residual energy on the plate with light.

AUTOMATIC ADJUSTMENT OF READING SENSITIVITY

The dynamic Range of IP is wide and linear over 10^4 : 1 of the X-ray dose. In order to utilize this exposure range, we adopted an automatic adjustment of reading sensitivity and gain by histogram analysis. The basic idea is shown in Figure 3. IP is first scanned roughly by weak laser beam and only a minor portion of the energy stored therein is read out in order to prepare the histogram of the images stored.

The histogram is analyzed by combining it with the data concerning anatomic region and radiographic technique to compute the exposure level and exposure range of stored image, thereby pre-set PMT sensitivity and the amplifier gain at the time the stored images are read out. This method will always offer the radiographs with optimum density.

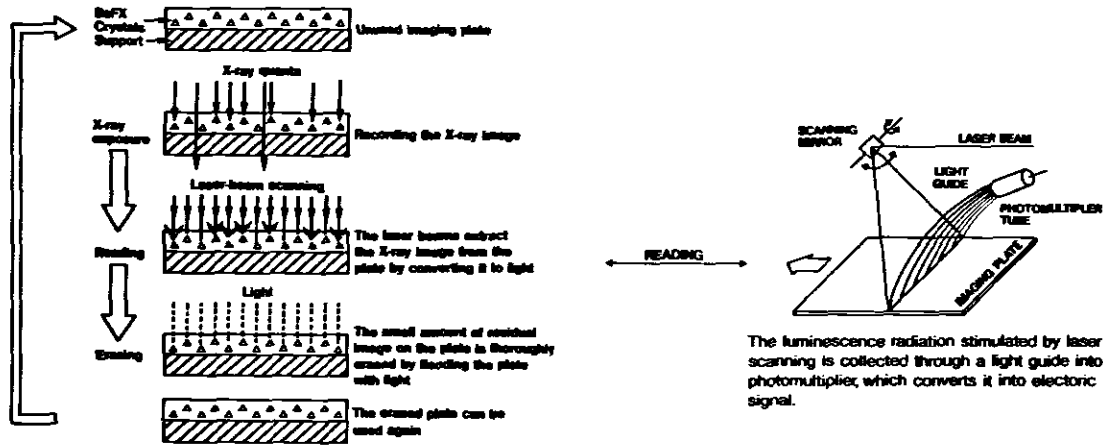

Figure 2. Principle involved in image recording, reading and erasing.

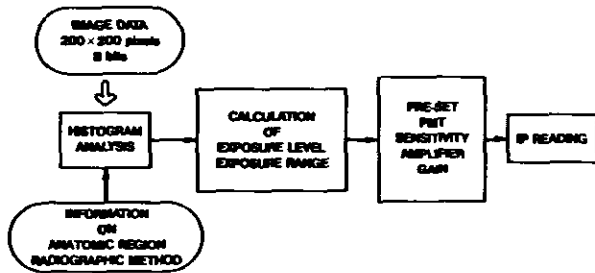

Figure 3. Basic principle of automatic IP reading.

This will be better understood by the operating characteristics curves shown in Figure 4. The first quadrant shows the characteristics of IP. The second quadrant shows the relationship between the input signals corresponding to the PSL radiation and the output digital signals of IMAGE READER. As mentioned above, the condition of reading sensitivity and dynamic range are automatically adjusted to the exposure conditions. For example, CASE A and B (quadrant I in Figure 4) represent higher exposure level and lower exposure level respectively. In this example, both cases have the same exposure range. These cases are read using different conditions (such as CONDITION A and B respectively) so that the output digital image signals are normalized and occupy the same range. The third quadrant shows the relationship between the input signals and output signals of IMAGE PROCESSOR. The digital image processing are conducted at this stage.

Finally, the fourth quadrant shows a sum of characteristics in the form of tonal reproduction curve, i.e., film-density versus X-ray exposure. In the screen-film system, only one reproduction curve is available since the sensitivity and dynamic range of the screen-film combination is fixed. In the CR system, however, arbitrary reproduction curves are possible because of the sensitivity and dynamic range adjust-

ment mechanism of the computer. Therefore, the image reproduction range of the CR system is much wider and flexible, compared with the conventional screen-film system.

Figure 5 shows the example of dosage reduction by automatic adjustment of reading sensitivity mechanism. The exposure conditions of the radiograph (A) were 80kVp and 15mR skin dosage, which were equal to those of conventional screen film system such as Fuj Hi-STD screen and Fuji RX film combination. On the other hand, The skin dosage to obtain the radiograph (B) was 3.8mR, that is 1/4 of conventional dosage.

DIGITAL IMAGE ENHANCEMENT

In order to obtain the sufficient image contrast, the digital image processing,³ particularly image enhancement tech-

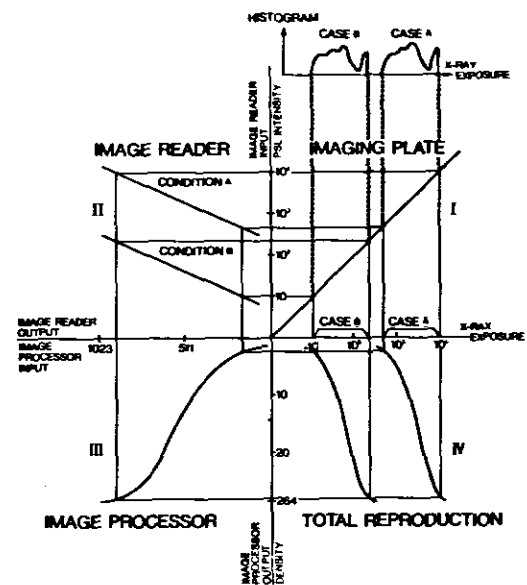

Figure 4. Operating characteristics of the CR system.

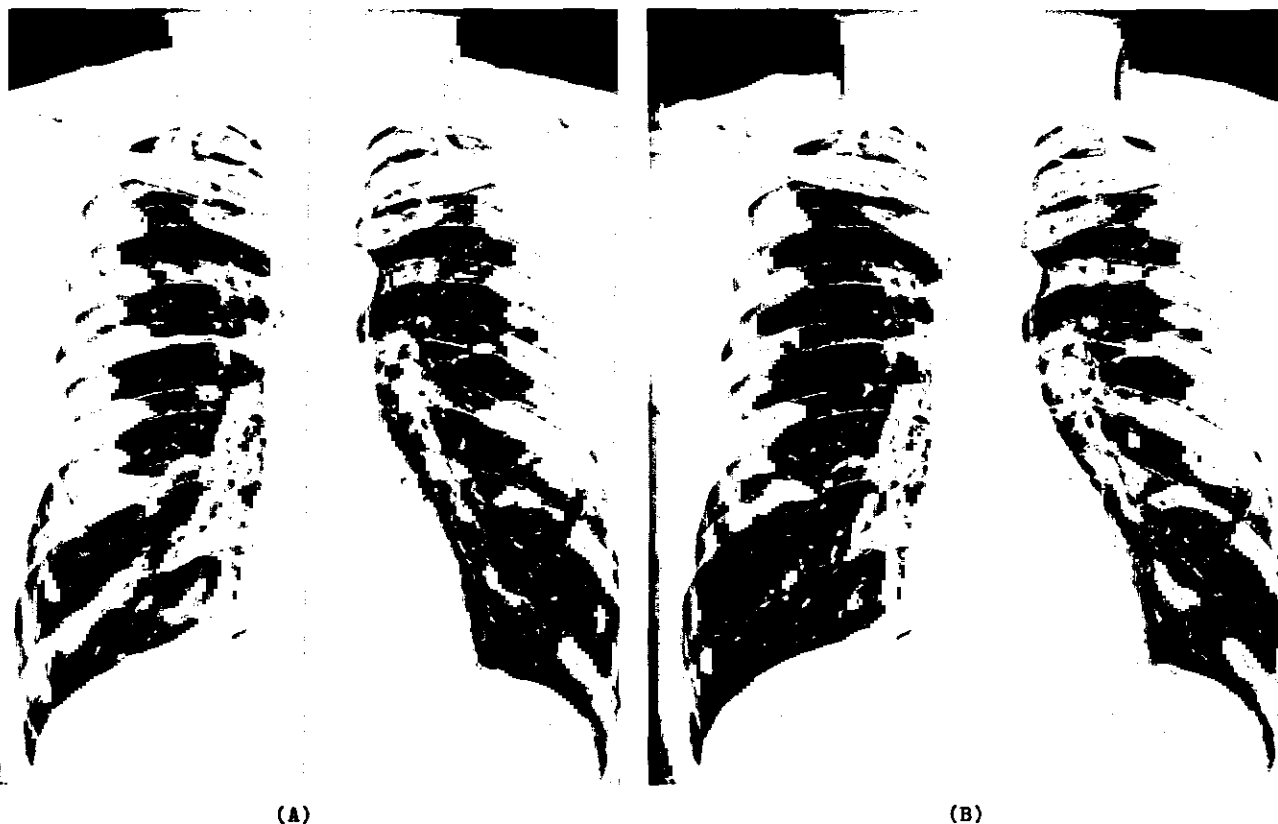

Figure 5. (A) Example of standard exposure level 80kVp, 15mR).
(B) Example of lower exposure level (80kVp, 3.8mR)

niques is applied adequately. Image enhancement techniques may roughly be classified into two, that is tonal conversion and spatial frequency modification. The former freely realizes the non-linear gradation by table-lookup algorithm, which is equivalent to varying the film characteristic curve in conventional radiography and may be illustrated in Figure 6.

As the latter technique, we employed the so-called "unsharp masking" technique shown in Figure 7. S_o and S_p are the original and processed image data, respectively. S_{us} is the blurred version of the original image data and K is the weighting factor for determining the magnitude of enhancement. The dashed line shows the frequency content of the difference between the original and blurred image.

By varying the degree of blurring for S_{us} and the weighting factor K , it is possible to control the frequency to be emphasized and the degree of such an emphasis.

The advantages of image enhancement techniques are demonstrated in the following radiographs. Figure 8 shows the chest radiographs of a 67-year-old man with the rounded opacities of pneumoconioses (P 1/1) the radiograph (A) was made by conventional screen-film system and the radiograph (B) was made by the CR system at the same exposure condition. Figure 9 shows the chest radiographs of

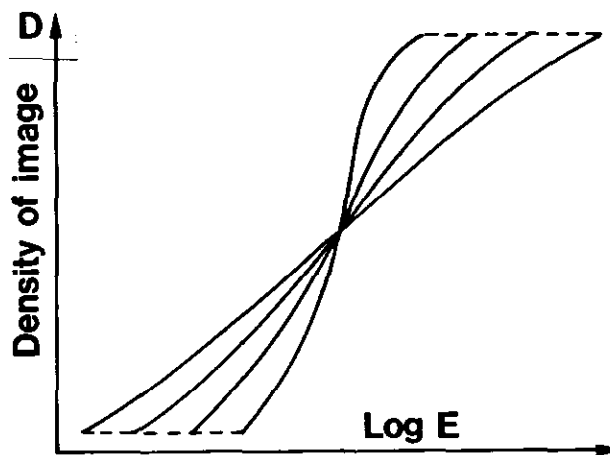

Figure 6. Tonal conversion.

a 69-year-old-man with the irregular opacities of pneumoconioses (S 2/2). Similar to Figure 8, the radiograph (A) and (B) were made by conventional screen-film system and the CR system respectively.

It may appear that both the rounded and the irregular opacities of pneumoconioses are seen much more clearly in the CR radiograph than in the conventional radiograph.

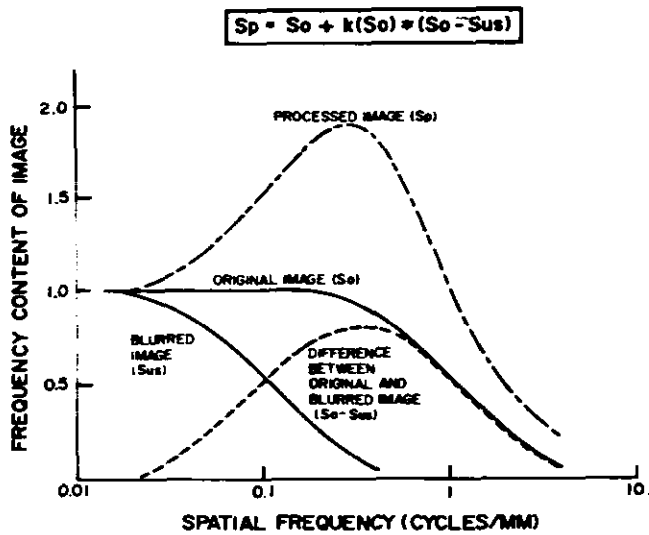

Figure 7. Spatial frequency modification.

FEATURES OF THE CR SYSTEM

The CR system is a new digital radiographic system which has possibilities in replacing the conventional screen-film system, in the field of the diagnosis of pneumoconioses, too.

The features of the system are summarized as follows:

1. Reduced dosage requirement.
2. Clear and wide latitude X-ray image suitable for accurate diagnosis.
3. Easy normalization of image quality by computer image processing.
4. Possible computer aided diagnosis such as computer classification of pneumoconioses.

These are very good features for the diagnosis of pneumoconioses.

On the other hand, computer aided diagnosis of pneumoconioses has been studied by several groups since the 1970's, and are intensively studied now with the advance of computer technologies. Some excellent results⁴⁻⁶ are presented in this conference; the VIIth International Pneumoconioses Conference (1988). In the near future, the good combination of the CR system which has the good features and the new type algorithm of computer classification of pneumoconioses will be developed and utilized in hospitals.

REFERENCES

1. Sonoda, M., Takano, M., Miyahara, J., Kato, H.: Computed Radiography Utilizing Scanning Laser Stimulated Luminescence. *Radiology* 148:833-838 (1983).

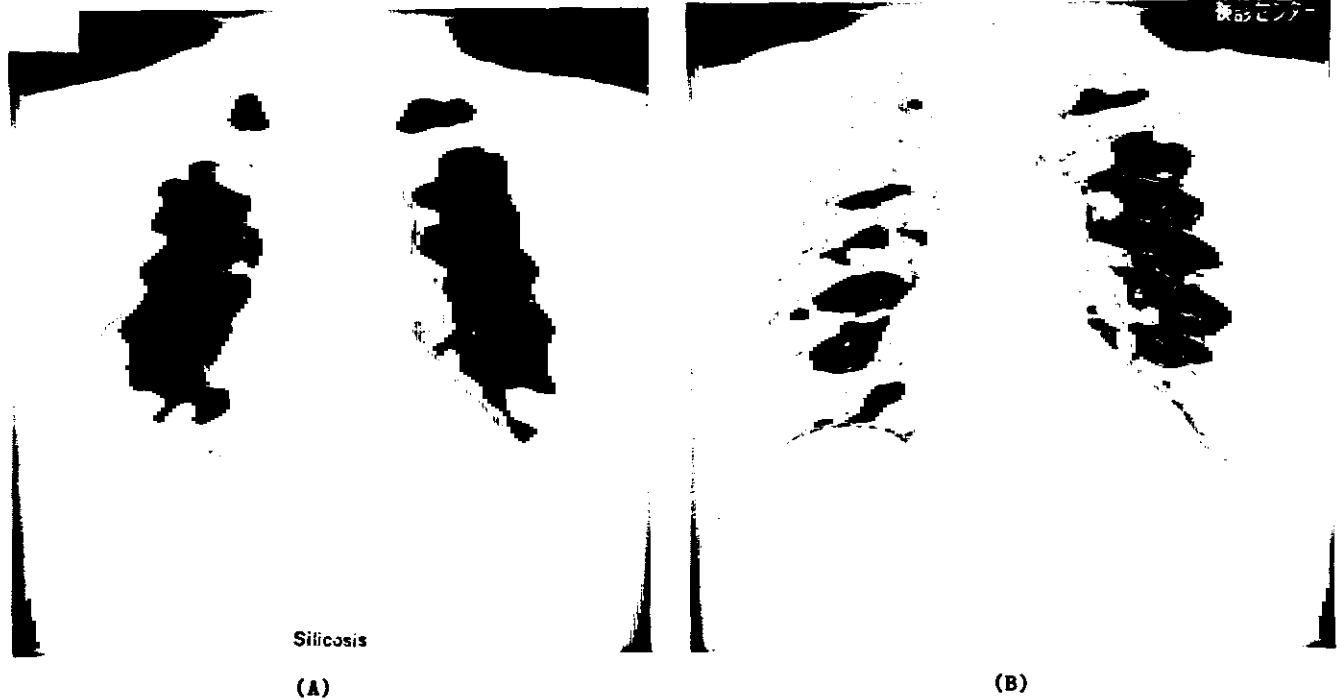

Figure 8. Chest radiographs of 67-year-old-man with the rounded opacities of pneumoconioses (1/1). (A) Example of conventional screen-film radiograph. (B) Example of computed radiograph by the Cr system.

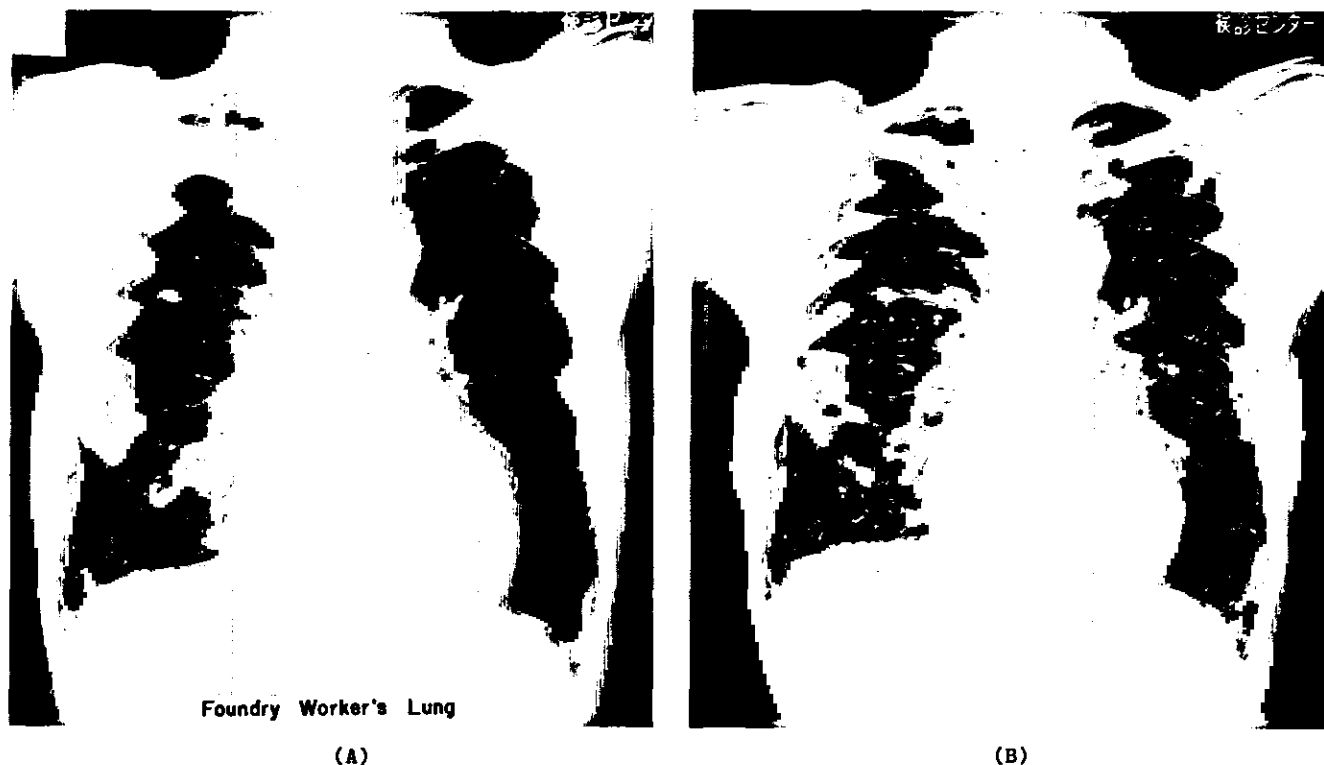

Figure 9. Chest radiographs of 69-year-old man with the irregular opacities of pneumoconiosis (S 2/2). (A) Example of conventional screen-film radiograph. (B) Example of computed radiograph by the CR system.

2. Leverenz, H.W.: *An Introduction to Luminescence of Solids*. Dover Publications, New York (1968).
3. Ishida, M., Kato, H., Doi, K., Frank, P.H.: Development of a new digital radiographic image processing system. *Application of Optical Instrumentation in Medicine X SPIE 347:42-48* (1982).
4. Nobechi, T., Tatenno, Y., Shida, H., Toriwaki, J., Kobatake, H., Hosoda, Y.: Application of Computed Radiography for Diagnosis of Pneumoconiosis. *Proceedings of the VIIth International Pneumoconiosis Conference*, Pittsburgh, Pennsylvania, Aug. 23-26 (1988).
5. Toriwaki, J., Hasegawa, J., Chen, X.: Measurement of Rounded Opacities in Lung of X-ray Images towards Quantitative Diagnosis of Pneumoconiosis. *Proceedings of the VIIth International Pneumoconiosis Conference*, Pittsburgh, Pennsylvania, Aug. 23-26 (1988).
6. Kobatake, H., Watanabe, T.: An Algorithm for the Detection of Small, Rounded Pneumoconiosis Opacities in Chest X-rays and its Application to Automatic Diagnosis. *Proceedings of the VIIth International Pneumoconiosis Conference*, Pittsburgh, Pennsylvania, Aug. 23-26 (1988).

ASBESTOS DISEASE IN COMMERCIAL ROOFERS: RADIOLOGIC SIGNS

DAVID C. CHRISTIANI, M.D., M.P.H. • Reginald Greene, M.D.

Harvard School of Public Health and Massachusetts General Hospital
Boston, Massachusetts, USA

Commercial roofers are mainly employed in constructing large flat roofs on relatively large buildings. There are two major processes involved: the removal, or "tear off," of an old roof prior to partial or complete replacement and the laying down of a new roof. Removal is often conducted down to the felt or insulation barrier. Initial tear-off involves use of a scratching machine, which has metal ribbed disks to break up the initial pitch gravel layer down to the felt and/or insulation. This is followed by a "power broom machine," which sweeps the gravel-pitch debris into wind rows on the roof. The gravel pitch is then shoveled by hand into small waste carts and transported to the side of the building for discarding via an enclosed chute to ground level. While loading the gravel pitch, the roof is scraped with shovels and other hand tools to assure that the surface is prepared for subsequent installation of a four-ply felt layer plus a top pitch-gravel layer. Removal of an entire roof entails using power claws and roof cutters to remove all layers, including insulation layers which may contain asbestos.

MATERIALS AND METHODS

Local 3 of the Roofers International Union represents 453 active and retired roofers. It represents approximately 30 percent of commercial roofers in the Boston metropolitan area. In 1987, the union sponsored a medical group survey program for members. The program provided a physical examination, chest X-rays, spirometry and detailed occupational and medical histories. The program was offered on a voluntary basis to any active or retired member with 10 or more years of membership in the union. Data was collected in June 1987. Chest X-rays of all 69 participants were read by a radiologist with extensive experience with pneumoconioses (R.G.). The radiologist had no knowledge of individuals' exposure history, other than their employment as a roofer. Chest X-ray interpretation was reported according to the ILO/UC 1980 Classification of Radiographs of Pneumoconioses.¹ For the purposes of this study, a profusion grade of 1/0 or higher on the ILO scale was considered evidence of interstitial parenchymal fibrosis. Notations of pleural thickening, diaphragmatic pleural plaques, pleural calcification of the diaphragm or chest wall were all considered evidence of pleural disease.

The recorded occupational history would not allow characterization of exposure to asbestos; therefore, we used length of union membership as a surrogate measure. Union membership records were available for all 69 participants.

RESULTS

The age distribution of the examined population was different from the membership as a whole (Table I). Two hundred and seventy-one, or 60% of the total membership, were members of the roofers for 10 or more years. Of these 271, 25% were examined in the survey. The members examined comprised more subjects in the 45-64 year age grouping, and less in the 25-34 year age group, than the union as a whole. The mean age of the examined population was 52 years, and mean number of years as a roofer was 29. The vast majority had more than ten years in the trade, with 74 percent having more than 20 years at the time of examination (Table II). Forty-six individuals, 67 percent of the population, had radiologic evidence of pleural disease (Table III). The mean age of this group was 54 years and mean years of membership 29 years. There was a significant relationship between years as a roofer and prevalence of pleural disease. Eighty percent of roofers with 20 or more years in the trade had evidence of pleural abnormalities, ($\chi^2 = 4.7$, $p < .05$).

In contrast, parenchymal abnormalities were uncommon, with only two (3 percent) individuals having radiologic evidence of fibrosis (Table IV). Both individuals with parenchymal fibrosis had more than 20 years membership in the union. There was no relationship between smoking status and the presence of pleural abnormalities (Table V).

DISCUSSION

This cross-sectional survey found that 67 percent of roofers who participated had radiologic abnormalities characteristic of asbestos-related pleural disease. The prevalence of pleural abnormalities increased with years of union membership, i.e., duration of exposure and time since first exposure. These data support the conclusion that roofers, like other members of the construction trades, have sustained significant occupational exposure to asbestos and are therefore at risk for developing asbestos-related disease.

Eighty percent of roofers with 20 or more years of union membership had evidence of pleural disease, with two (2.5 percent) having evidence of parenchymal fibrosis (asbestosis).

The rate of pleural abnormalities in this population of roofers is substantially higher than those found in unexposed populations.² However, cross-sectional studies of other construc-

Table I
Age Distribution of Union Membership and Roofers Examined

Age (Years)	Percentage of Union Union Membership (N = 288)	Percentage of Population Examined (N = 69)
0-24	3	0
25-34	23	4
35-44	17	16
45-64	42	71
65+	15	9
TOTAL	100	100

Table II
Population Examined by Years of Union Membership

Years of Membership	N	Percentage
≤10	1	1
11-20	17	25
21-30	20	29
30+	31	45
	69	100

Table III
Prevalence of Pleural Abnormalities

Years as Roofer	Number Examined	N	Percentage
≤10	1	1	-
11-20	17	8	47
20+	51	37	80
TOTAL	69	46	67

$\chi^2 = 4.7$, $p < .05$ for prevalence < 20 years vs. > 20 years.

Table IV
Prevalence of Interstitial Opacities

Years as Roofer	Number Examined	N	Percentage
≤10	1	0	0
11-20	17	0	0
20+	51	2	4
TOTAL	69	2	3

Table V
Pleural Abnormalities and Smoking Status

	Number Examined	N	Percentage
Current	30	16	53
Ex-	30	23	77
Non-	9	7	78
TOTAL	69	46	67

$$\chi^2 = 3.25, p > 0.05$$

tion trades workers have revealed high prevalences of asbestos-related abnormalities, particularly pleural abnormalities. Baker et al. found pleural abnormalities in 70 percent of sheet metal workers who had 30 or more years of employment.³ Sprince et al. found pleural thickening in 31 percent of a group of actual and retired pipefitters with more than 20 years since first exposure who attended a voluntary medical screening.⁴ Michaels et al. reported that sheet metal workers with 20 or more years of union membership had a prevalence of 29 percent of X-ray abnormalities characteristic of pleural and/or parenchymal disease due to asbestos.⁵ The differences in reported prevalences among construction workers in these studies is likely to result from differences in exposure among populations studied and differences in X-ray interpretation. Nevertheless, it is clear that asbestos-related abnormalities, predominantly pleural diseases, are prevalent in these populations.

This study is limited in two respects. First, relatively small numbers (i.e. 25% of eligible workers) limits accurate esti-

mation of prevalence. Second, the program was voluntary and it is therefore possible that disease status or exposure influenced participation.

The age distribution of participants differed from the union as a whole. However, reported prevalences of pleural and parenchymal abnormalities actually may be underestimates in the group with more than 10 years of exposure, since many non-participants were of retirement age in this group.

Benign pleural abnormalities resulting from exposure to asbestos include parietal pleural plaques along the chest wall and diaphragm, pleural calcification of plaques, diffuse visceral pleural thickening and rounded atelectasis. In addition, pleural effusions in the absence of malignancy have been described in asbestos-exposed workers, usually early in their careers.⁶ All of these conditions (as well as the malignant manifestations of asbestos exposure) may be seen in roofers. Our data suggest that pleural abnormalities are extremely common in roofers with more than 20 years of work.

Our findings emphasize the need for medical surveillance of all asbestos-exposed construction workers. Our findings should also alert clinical practitioners to the type of radiologic abnormalities commonly seen among commercial roofers. Furthermore, while the OSHA standard mandates medical surveillance for currently exposed workers,⁷ our data suggest that workers with past exposure and retirees be included in such programs. In addition, since the potential for on-going asbestos exposure exists during old roof removal, appropriate control of exposure needs to be rigorously implemented.

REFERENCES

1. International Labor Organization: ILO/UC International classification of radiographers of pneumoconiosis. In *Occupational Safety and Health Series*, No. 22 revised. Geneva: International Labor Organization (1980).
2. Castellan, R.M., Sanderson, W.T., Petersen, W.R.: Prevalence of radiographic appearance of radiographic appearance of pneumoconiosis in an unexposed blue collar population. *Am. Rev. Respir. Dis.* 131:684-686 (1985).
3. Baker, E.L., Dagg, T., Greene, R.E.: Respiratory illness in the construction trades: #1. The significance of asbestos-associated pleural disease among sheet metal workers. *J. Occup. Med.* 27:483-489 (1985).
4. Sprince, N.L., Oliver, L.C., McCloud, T.C.: Asbestos-related disease in plumbers and pipefitters employed in building construction. *J. Occup. Med.* 27:771-775 (1985).
5. Michaels, D., Zoloth, S., Lacher, M., Holstein, E., Lillis, R., Drucker, E.: Asbestos disease in sheet metal workers: II. Radiologic Signs of Asbestosis among Active Workers. *Am. Jour. Industr. Med.* 12:595-603 (1987).
6. Epler, G., McCloud, T.C., Gaensler, E.A.: Prevalence and incidence of benign asbestos pleural effusion in a working population. *JAMA*, 247:617-622 (1982).

POSSIBLE OCCUPATIONAL PULMONARY ALVEOLAR PROTEINOSIS (PAP)

S. MANDEL • V. Kapil

Occupational Medicine Physician Associates
Detroit, Michigan, USA

ABSTRACT

This is a case of a 39 year old man with pulmonary alveolar proteinosis (PAP) which appeared at least temporarily, related to work place exposures. In July of 1985 the patient began to work for a company which manufactures mobile homes. Although his job was restricted to mechanical tasks such as installing doors and windows, he was exposed to glue and laminate vapors. There was a fiberglass shop adjacent to his work station. After working there for approximately six weeks he developed acute chest pain and shortness of breath initially diagnosed as pneumonia. Subsequent workup and bronchoalveolar lavage confirmed the diagnosis of PAP. He underwent additional therapeutic lavages, and has been feeling well since.

We were able to locate chest X-rays from 1983 which demonstrate interstitial markings. It is also true that the patient's symptoms persisted past the cessation of occupational exposures until the lavage was performed. On the other hand there is literature which suggests that hydrocarbons and other chemicals are associated with 50% or more of PAP cases.

The poster presentation will include a short personal and occupational history. Copies of serial chest X-rays and slides of lavage cytology will also be shown. Our patient was treated unsuccessfully by a number of physicians. It is important to maintain a high index of suspicion among occupational physicians who are caring for workers exposed to hazardous airborne substances despite their relative rarity of this condition.

No Paper provided.

SUBPLEURAL CURVILINEAR SHADOW IN INTERSTITIAL PULMONARY DISEASES

HIROTOMO KASUGA, M.D. • Nobihiro Narita, M.D. • Moka Tamura, M.D. • Satoru Morikawa, M.D.
 • Hitoshi Katada, M.D. • Ryuji Miyazaki, M.D. • Masayuki Hatakeyama,* M.D.
 • Hideaki Otsuji,* M.D. • Hitoshi Yoshimura,† M.D. • Hideo Uchida,* M.D.

The Second Department of Internal Medicine, Nara Medical University, Kashihara-shi, Nara 634

*The Department of Radiology, Nara Medical University

†The Department of Cancer Radiology, Nara Medical University

Chest radiographic findings in pulmonary asbestosis have been studied,^{1,2} and pulmonary asbestosis is mainly diagnosed by irregular opacities on chest radiographs.³ However, computed tomographic (CT) findings have not been studied to the same extent as radiographic findings. In our previous study,⁴ we revealed a line parallel to the inner chest wall in the lung on high-resolution CT alone, and we called it subpleural curvilinear shadow (SCLS, Figure 1).

In this study, to analyze the significance of the SCLS in pulmonary asbestosis, we studied the prevalence rate of the SCLS in several interstitial pulmonary diseases and in asbestos workers with normal chest roentgenograms.

MATERIALS (Table I)

Twenty-two patients with pulmonary asbestosis (ASBESTOSIS) were examined. They were 21 men and a

woman ranged in age from 40 to 64 years (mean; 53 years) and ranged in duration from the first exposure to asbestos from 15 to 43 years (mean; 30 years). By ILO classification, 12 of ASBESTOSIS had category 1 (1/0, 1/1, 1/2), 7 had category 2 (2/1, 2/2, 2/3), and 3 had category 3 (3/2, 3/3, 3/+) disease. For the controls, 33 patients with idiopathic pulmonary fibrosis (IPF), 23 patients with interstitial pneumonia due to collagen vascular diseases (CVD), and 102 patients with lung cancer admitted to our hospital during the last one year (LC) were examined. The IPF group consisted of 29 men and 4 women ranged in age from 49 to 78 years (mean; 66 years). The CVD group included 11 patients with rheumatoid arthritis (7 men and 4 women), 6 with progressive systemic sclerosis (a man and 5 women), 3 women with polymyositis or dermatomyositis, 2 women with mixed connective tissue disease, and a woman with systemic lupus erythematosus. They were ranged in age from

Table I
 Characteristics of the Materials

	n (male)	age (range) [yrs]	exposure (range) [yrs]
ASBESTOSIS	22 (21)	53 (40-64)	30 (15-43)
IPF	33 (29)	66 (49-78)	-
CVD	23 (8)	55 (35-83)	-
L C	102 (83)	63 (32-82)	-
WORKERS	22 (18)	49 (35-61)	27 (14-43)

Note-- ASBESTOSIS; patients with pulmonary asbestosis
 IPF; patients with idiopathic pulmonary fibrosis
 CVD; patients with interstitial pneumonia due to
 collagen vascular diseases
 LC; patients with lung cancer
 WORKERS; current asbestos workers with normal
 chest roentgenograms
 exposure; duration from the first exposure to
 asbestos dust



Figure 1. Subpleural curvilinear shadow (SCLS).

35 to 83 years (mean; 55 years). The LC group consisted of 83 men and 19 women ranged in age from 32 to 82 years (mean; 63 years).

Twenty-two current asbestos workers (WORKERS) with normal chest roentgenograms (ILO category 0) were also examined. They were 18 men and 4 women ranged in age from 35 to 61 years (mean; 49 years) and ranged in duration of exposure to asbestos from 14 to 43 years (mean; 27 years).

METHODS

A GE CT/T 8800 whole-body scanner (General Electric Medical Systems, Milwaukee, Wis.) was used for this study. High-resolution CT scanning (target reconstruction of the

bone detail) was performed in all cases. The scan time was 9.6 seconds and section thicknesses were 1.5 mm or 2 mm. The window level was set at -550 and the window width at 2000 Hounsfield units. In determining the presence of SCLS, an SCLS shorter than 1 cm in length was excluded.

In the first study, the prevalence rates of SCLS were compared among several interstitial pulmonary diseases (ASBESTOSIS, IPF and CVD) and non-interstitial pulmonary disease (LC). In LC, the lung regions without tumor were examined.

In the second study, following the evaluation of the SCLS prevalence rate in WORKERS, sex, age, duration of asbestos

exposure, and smoking habit were compared between WORKERS with and without SCLS.

In the third study, CT findings including SCLS and honey comb shadow (HC) were compared with ILO classification in both ASBESTOSIS and WORKERS. CT findings were classified to five types (Figure 2) according to our previous study;⁴ type 0 has no SCLS and HC, type I has SCLS without other pulmonary abnormality or with abnormality located only peripherally, type II has HC located in the subpleural zone, type III has HC spreading intermediate between types II and IV, type IV has HC spreading to the hilar region.

tween types II and IV, and type IV has HC spreading to the hilar region.

RESULTS

In the first study (Table II), we observed SCLS in 17 (77%) of 22 cases with pulmonary asbestosis. SCLS was also detected 7 (21%) of 33 patients with IPF and 9 (39%) of 23 patients with CVD. But in LC, SCLS was not detected. The SCLS prevalence rate in ASBESTOSIS was statistically higher than in IPP and in CVD ($p < 0.001$).

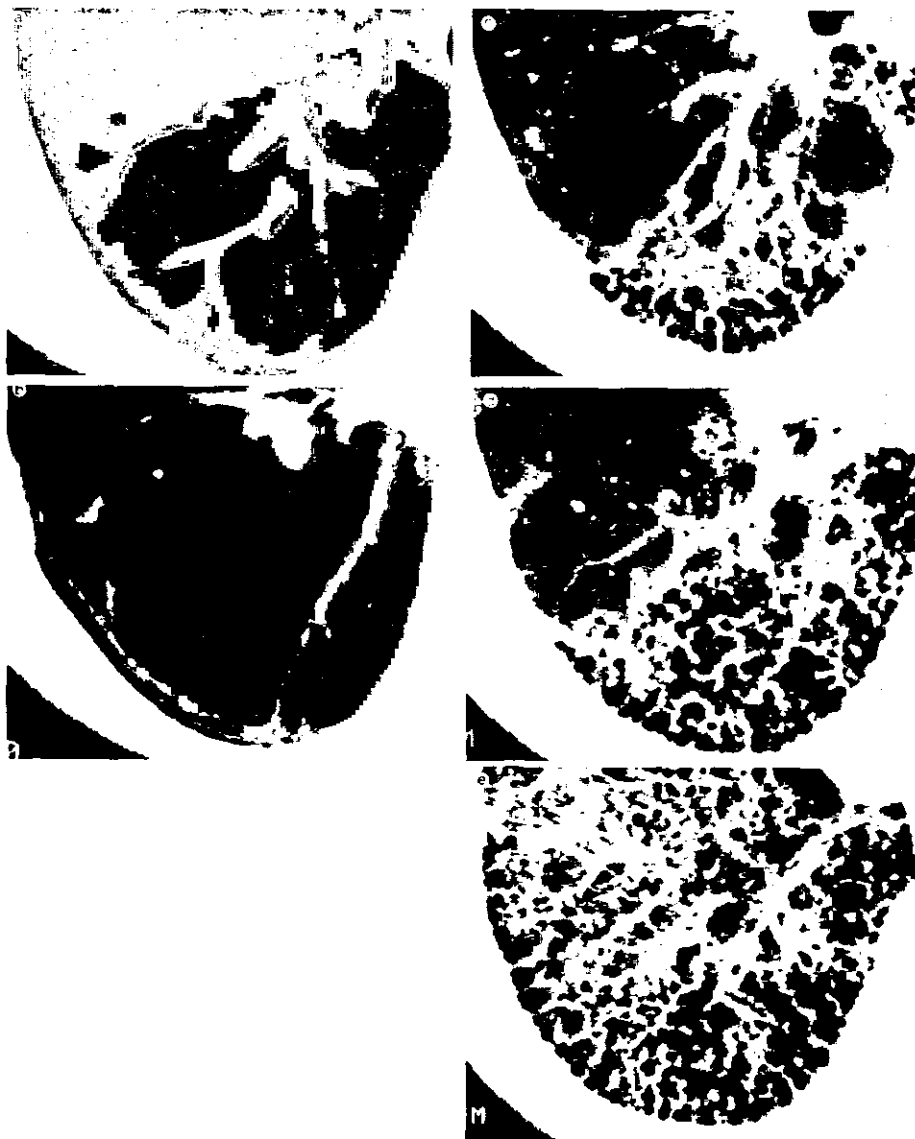

Figure 2. CT classification.

- a: type 0; no SCLS and no honey comb shadow (HC)
- b: type I; SCLS without other pulmonary abnormality or with abnormality located only peripherally
- c: type II; HC located in the subpleural zone
- d: type III; HC spreading intermediate between types II and IV
- e: type IV; HC spreading to the hilar region

In the second study (Table III), we observed SCLS in 7 (33%) of 22 cases in spite of their normal chest roentgenograms. And there were statistically no differences between WORKERS with and without SCLS in sex, age, duration of asbestos exposure, and smoking habit.

In the last study (Table IV), the relationship between ILO and CT classification in both ASBESTOSIS and WORKERS were evaluated. Of the 3 patients with ILO classification category 3 and CT classification type IV, 2 patients without SCLS had wide spreading HC from their lower lobes to their apices. Excluding these 2 severe cases, the SCLS prevalence rates were increasing in proportion to ILO classification.

DISCUSSION

In our previous study,⁴ radiologic-pathologic correlation was described in one postmortem lung sample. The patient was a 55-year-old man with pulmonary asbestosis (ILO category 1). He had the SCLS in the right lower lobe. He died of respiratory failure 3 months later, and an autopsy was performed. It was made clear that the structure of SCLS was consisted of peribronchiolar fibrotic thickening with anthracosis joined by flattening and collapse of the alveoli with fibrosis. In other words, SCLS had a histologic pattern of fibrosing bronchiolo-alveolitis. This histologic finding is characteristic of pulmonary asbestosis, especially fibrosing bronchiolitis is known to be initial change of pulmonary asbestosis.

Following our previous study, several studies of high-resolution CT findings about pulmonary asbestosis were

reported. Friedman et al. made use of SCLS for one of the criteria to diagnose pulmonary asbestosis.⁷ Aberle et al. also reported SCLS (they called it "curvilinear subpleural line") was observed in 28% of 29 patients with pulmonary asbestosis.⁵

In the first study, we were able to observe SCLS not only in pulmonary asbestosis (ASBESTOSIS) but also in idiopathic pulmonary fibrosis (IPF) and interstitial pneumonia due to collagen vascular diseases (CVD). But no SCLS were detected in lung cancer (LC). From this results, the SCLS on high-resolution CT seemed one of the findings of interstitial pulmonary diseases. However, the prevalence rate of SCLS was markedly higher in ASBESTOSIS than in IPF and in CVD, and so the SCLS was supposed to be a more characteristic finding in ASBESTOSIS.

In the second study, we observed similar SCLS in one-third of current asbestos workers (WORKERS). They had been exposed to asbestos dust during 27 years in average but they had no findings of pulmonary asbestosis on their chest roentgenograms. And in the next study the backgrounds were compared between WORKERS with and without SCLS. But there were no differences between them. The cause of appearance of SCLS seemed not only the length of duration of asbestos exposure or smoking habit, but also individual constitution of each person and so on.

In the last study including ASBESTOSIS and WORKERS, the SCLS prevalence rates were increasing in proportion to ILO classification. These results supported the hypotheses that the SCLS was one of the common findings in pulmonary asbestosis and that the SCLS shown in asbestos workers with normal chest roentgenograms was an early change of pulmonary asbestosis. In our histologic survey,⁴ the structure of SCLS was also compatible to the initial change of pulmonary asbestosis.

From the results mentioned above, we concluded that SCLS on high-resolution CT scan was useful for early detection of pulmonary asbestosis in asbestos workers.

REFERENCES

1. Souter, C.A., Simon, G., Turner-Warwick, M.: The Radiology of Asbestos-Induced Disease of the Lungs. *Br. J. Dis. Chest* 68:235-252 (1974).
2. Selikoff, I.J., Lee, D.H.K.: *Asbestos and Disease*, pp. 157-164. Academic Press, New York (1978).

Table II
Prevalence Rate of SCLS in Several
Interstitial Pulmonary Diseases

	n	SCLS (%)
ASBESTOSIS	22	17 (77)
IPF	33	7 (21) *
CVD	23	9 (39) *
L C	102	0 (0)

Note-- * p<0.001 against
ASBESTOSIS

Table III
Comparison of Background between Asbestos Workers with and without SCLS

	n	male (%)	age	exposure	smoker (%)
SCLS (-)	15	12 (80)	49 ±5	27 ±7	9 (60)
SCLS (+)	7	6 (86)	49 ±8	28 ±9	6 (86)

Note-- smoker; both current smokers and exsmokers

Table IV
Relationship between ILO and CT Classification in Patients with
Pulmonary Asbestosis and Asbestos Workers

C T classification	ILO classification				total
	0	1	2	3	
type 0	14 (0)	1 (0)			15 (0)
I	7 (7)	6 (6)			13 (13)
II	1 (0)	4 (2)	4 (4)		9 (6)
III		1 (1)	3 (3)		4 (4)
IV				3 (1)	3 (1)
total	22 (7)	12 (9)	7 (7)	3 (1)	44 (24)

Note-- Numbers in parentheses indicate patients with SCLS

- International Labour Office. ILO International Classification of Radiographs of Pneumoconiosis. Geneva (1980).*
- Yoshimura, H., Hatakeyama, M., Otsuji, H., Maeda, M., Ohishi, H., Uchida, H., Kasuga, H., Katada, H., Narita, N., Mikami, R., Konishi, Y.: Pulmonary Asbestosis; CT Study of Subpleural Curvilinear Shadow. *Radiology* 158:653-658 (1986).
- Craighead, J.E., Abraham, J.L., Churg, A.: The Pathology of Asbestos-Associated Diseases of the Lungs and Pleural Cavities; Diagnostic Criteria and Proposed Grading Schema. *Arch. Pathol. Lab. Med.* 106:544-576 (1982).
- Green, F.H.Y., Attfield, M.: Pathology Standards for Asbestosis. *Scand. J. Work Environ. Health* 9:162-168 (1983).
- Friedman, A.C., Fiel, S.B., Pisher, M.S., Radecki, P.D., Lev-Toaff, A.S., Caroline, D.P.: Asbestos-Related Pleural Disease and Asbestosis; A Comparison of CT and Chest Radiography. *A.J.R.* 150:269-275 (1988).
- Aberle, D.R., Gamsu, G., Ray, C.S., Feuerstein, I.M.: Asbestos-Related Pleural and Parenchymal Fibrosis; Detection with High-Resolution CT. *Radiology* 166:729-734 (1988).

DO SILICON-OXYGEN RADICALS PLAY A ROLE IN THE QUARTZ-INDUCED HEMOLYSIS AND FIBROGENICITY?

NAR S. DALAL* • Xianglin Shi* • Val Vallyathan†

*Department of Chemistry, West Virginia University, Morgantown, WV 26506, USA

†Department of Pathology, West Virginia University, Morgantown, WV 26506, USA

INTRODUCTION

In an earlier communication¹ from our laboratory it was reported that mechanical crushing of coal and quartz under normal air atmosphere generates of free radicals on the particle surfaces, and that these radicals decay with time, hence pointing to a higher toxicity of fresh dusts in relationship to pneumoconiosis and silicosis. More recently Fubini et al.² have also reported the detection by electron spin resonance (ESR) of the formation of SiO• and Si•-type of radicals from quartz particles crushed under atmospheric conditions. In agreement with earlier ESR studies on single crystals of quartz crushed under high vacuum (~10⁻¹⁰ torr)³ and subsequent exposure to air,³ and to other gases,⁴ these radicals were identified² as being formed by the homolytic cleavage of the Si-O-Si bonds and the reactions of the Si• and SiO• radical with atmosphere. Fubini et al.² also suggested that these radicals might be involved in the mechanism of the fibrotic action by silica, either by transforming the particle surface into a selective oxidating agent or as an initiator of a sequence of reactions leading to fibrosis. Earlier Gabor and Anca⁵ had reported that lipid peroxidation caused by free radicals on the silica surface might be involved in the red blood cell membrane damage. Thus far, however, no parallel cytotoxicity, fibrogenicity, and free radical studies on a given quartz dust sample have been reported, except for some earlier work from our laboratory.^{1,6,7} We now present more recent results obtained from parallel cytotoxicity, fibrogenicity, and free radical measurements on a freshly made quartz dust. The dust's free radical content was measured using ESR spectroscopy while its cytotoxicity potential was estimated via hemolysis. Hemolysis was employed as the toxicity test because it is a widely used method for estimating the potential of a dust for disrupting the cell membrane.⁸ The fibrotic potential was followed by measuring the dust-induced lipid peroxidation, using linoleic acid as a model lipid. As discussed below, the results obtained suggest new clues to the mechanism of the quartz-related cytotoxicity and fibrogenicity.

MATERIALS AND METHODS

Reagents

Crystalline quartz particles with a size range of 0.2–2.5 mm were obtained from the Generic Respirable Dust Technology Center, Pennsylvania State University, University Park, Pennsylvania. These particles were crushed in air to obtain

quartz dust samples with particle sizes smaller than 20 microns. We chose to work with a dust with mixed particle sizes, rather than a specific range, as an effort to simulate the mining atmosphere. An agate mortar-pestle arrangement was used for the crushing and grinding because of the close similarity of the structure of agate to that of quartz. Diethylenetriaminepentaacetic acid (DETAPAC) were purchased from Sigma. All other chemicals were purchased from Fisher or Aldrich.

Hemolysis Experiments

Hemolytic activity of silica was measured, following an established procedure,⁹ as the amount of hemoglobin released from a 2% suspension of sheep erythrocytes after incubation with 10 mg of silica dust for one hour at 37°C. The hemoglobin release was estimated via the absorbance at 540 nm using a Giorford spectrophotometer. The procedure was calibrated by substituting the silica dust by a phosphate buffer solution as a negative control (background) and 0.5% Triton-X-100 as a positive control (100% hemolysis). The percentage of hemolysis was calculated as follows:

$$\% \text{ Hemolysis} = (I_{\text{silica}} - I_{\text{neg}}) / (I_{\text{pos}} - I_{\text{neg}})$$

where I_{silica} is the absorbance after incubation with the silica dust, while I_{neg} and I_{pos} are those with buffer only and 0.5% Triton-X-100, respectively.

Lipid Peroxidation Measurements

Peroxidation of the polyunsaturated lipid linoleic acid (cis-9-cis-12-octadecadienoic acid) by freshly ground or aged silica was monitored using a fluorescence method¹⁰ with minor modifications. The reaction mixture in a total volume of 0.5 ml contained freshly ground or aged silica and 20 µl of 0.52 mM linoleic acid emulsion in 95% ethanol in HEPES buffer (pH 7.4) with calcium and glucose. The mixture was heated for one hour in a shaking water bath at 37°C. This procedure was followed by the addition and mixing of 0.5 ml of 3% sodium dodecyl sulfate and then of 2.0 ml 0.1 N HCl, 0.3 ml 10% phosphotungstic acid and 1.0 ml 0.7% 2-thiobarbituric acid. The mixture was then heated for 30 min at 95–100°C and the reactive substance formed was extracted with 5 ml 1-butanol after cooling. The extraction was then centrifuged at 3000 rpm for one minute and the fluorescence of the butanol layer was measured using a

515 nm excitation and 555 nm emission, with a Perkin-Elmer fluorospectrophotometer (Model MPG-36). Malondialdehyde standards were prepared from 1,1,3,3-tetramethoxypropane to obtain a calibration curve, which was used for calculating the amounts of malondialdehyde produced.

ESR Measurements

ESR spectroscopy was used for identifying the crushing-induced silicon-oxygen radicals, and to follow their concentration as described elsewhere.^{1,6,7} The ESR measurements were made with a Bruker ER 200D spectrometer operating at X-band (~9.5 GHz) frequencies, and 100 kHz magnetic field modulation. The magnetic field was calibrated with a self-tracking NMR gaussmeter (Bruker, model ERO35M). The microwave frequency was measured with a Hewlett-Packard, Model 5340A, digital frequency counter. All ESR measurements were made at room temperature.

RESULTS AND DISCUSSION

Figure 1 shows a typical, room temperature, ESR spectrum of freshly ground quartz particles. The spectrum is not identical but similar to those reported earlier for the measurements made at room temperature and ambient air environment.^{1,2} Here we focused on the major species, characterized by $g = 2.0015$, and assigned to a combination of silicon-oxygen radicals.^{1,2} To correlate the radical content with hemolysis, it was necessary to control the radical concentration. The first method used for this was thermal annealing. Thus the free radical concentration was measured via ESR (at room temperature) after thermal annealing from 50° to 800°C for 30 minutes at each temperature. Figure 2 shows the change in the radical concentration on thermal treatment (Plot A) and the corresponding hemolysis measurements (Plot B). The data for the samples heated above 300°C show that while the free radical content decreases sharply with the heat treatment above 300°C, the hemolytic potential remains virtually unchanged for heating up to 550°C, and starts to decrease on further heating only. It, thus, follows that there is little, if any, direct correlation between the concentration of the free radicals and the hemolytic potential of the dust samples.

Second, measurements of both the radical concentration and the hemolytic potential were made at several time intervals after the dust preparation. Figure 3 shows the time dependence of the free radical concentration on storing the dust in air after grinding (Plot A) and the hemolysis induced by the same sample (Plot B). It is seen that while the radical concentration decreases with a half-life of about one and a half day, in agreement with our earlier studies,^{1,5,7} the hemolytic potential does not change noticeably over at least two weeks, again showing that the grinding-induced radicals on the quartz particles do not play any direct role in the mechanism of this hemolysis by quartz particles.

As the third method for controlling the radical concentration, some freshly ground quartz particles were boiled in a phosphate buffer for about 30 minutes. ESR measurements on these samples showed that their radical concentration decreased to about 10%, while their hemolytic activity decreased to almost zero. In order to find if this decrease was related to the silicon-oxygen radicals, experiments were

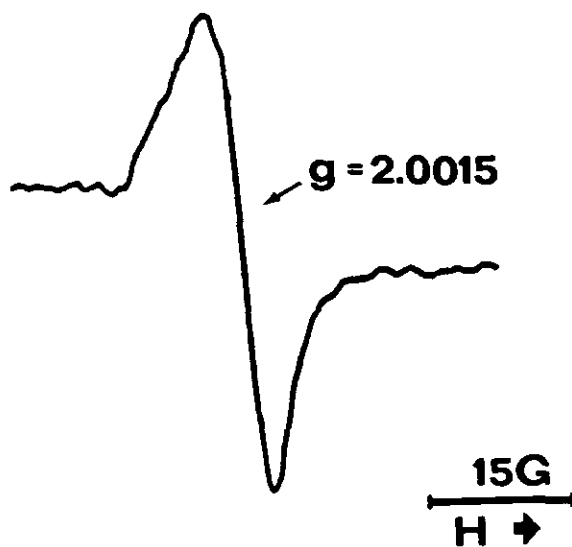

Figure 1. A typical, room temperature, ESR spectrum of freshly ground quartz particles.

conducted as an attempt to restore the hemolytic activity. It was found that while an exposure to a phosphate buffer or a KMnO_4 solution (a strong oxidant) did not restore the hemolytic activity, the addition of DETAPAC, a strong metal chelate, to the incubation medium restored the activity to about 60%. Thus, this boiling-induced reduction in the silica's hemolytic potential cannot be attributed to the loss of the radicals on boiling, since it is unlikely that the addition of DETAPAC could restore the silicon-oxygen radicals. These results seem to indicate that the attachment of metal ions to the particle surfaces causes the loss in the hemolytic activity by quenching certain reactive (surface) sites. This conclusion is not unprecedented since earlier hemolysis studies⁸ have shown that the presence of metal ions such as Al^{3+} causes a significant decrease in the quartz dust's hemolytic potential. We indeed confirmed that addition of Al^{3+} , Cu^{2+} , or Fe^{2+} ions, at about 1.0 mM concentration, to the incubation medium results in the loss of the hemolytic activity. The new result obtained here is that the subsequent addition of DETAPAC restores it, implying that the metal ions were only loosely bonded to the silica surface.

The above results are consistent with an earlier suggestion⁸ that surface silanol (SiOH) groups play a key role in the mechanism of hemolysis by quartz particles. Metal ions are expected to be bonded via the surface silanol (SiOH) groups by replacing the H^+ ions, thus reducing the number of silanol groups responsible for red blood cell membrane damage.⁸ Infrared studies on heated silica-gel¹¹ and silica surfaces¹² demonstrated that silanol groups are formed on the silica surface, and that these moieties are annealed only if silica is heated to higher than 700°C.^{11,13} Since the present work shows that the hemolytic activity of silica decreases markedly on heating to 700°C (Figure 2), the role of the silanol groups in the hemolysis by silica seems fairly well established. This finding is consistent with an earlier

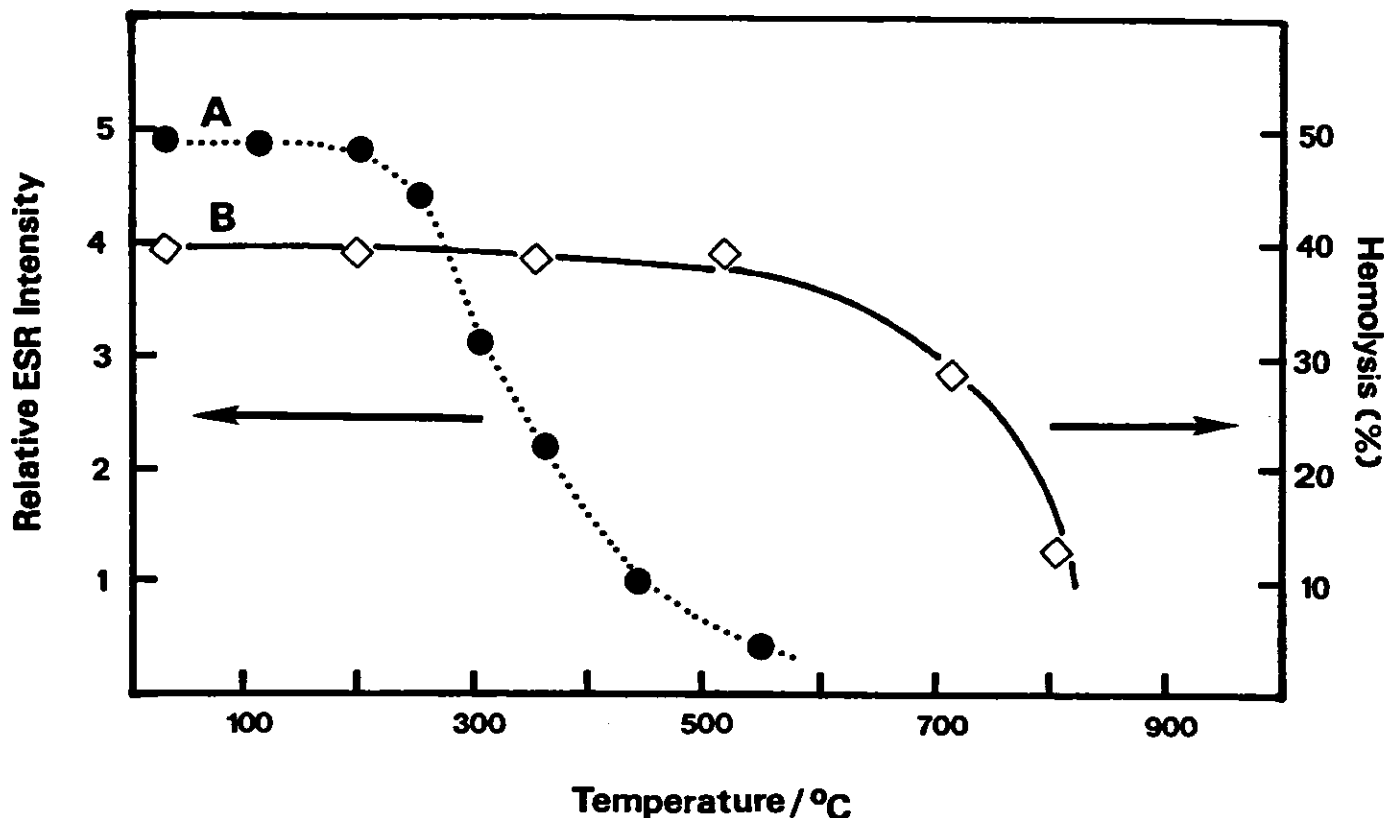

Figure 2. The effect of heating on the ESR intensity of the grinding-induced silicon-oxygen radicals, plot A(●), and silica-induced hemolysis by the same samples, plot B (◇).

report⁸ of the reduction in the silica toxicity by Al^{3+} and polyvinyl-pyridine-N-oxide (PVPNO).

For obtaining further clues to the mechanism of silica's fibrogenicity, we investigated the possible relationship between silicon-oxygen radicals on fresh dust particles and the dust's lipid peroxidation potential by parallel measurements of the time dependence of radical content by ESR and of the silica-induced lipid peroxidation using linoleic acid as a model lipid.¹⁰ Figure 4 shows the time dependence of the lipid peroxidation. It is seen that the ability of freshly ground silica to peroxidize a lipid decreases on storage, since the rate of silica-induced lipid peroxidation declined markedly over the first 48 hours after grinding and remained fairly constant thereafter. The similarity of the time dependence of the lipid peroxidation (Figure 4) with the decay behavior of the silicon-oxygen radicals (Figure 3, plot A) indicates that these radicals might be directly or indirectly involved in this silica-induced lipid peroxidation, which may result in a progressive degeneration of the membrane structure and eventual loss of membrane activity¹⁴

In conclusion, this work shows that the fracture-induced silicon-oxygen radicals are not directly involved in the mechanism of the erythrocyte hemolysis by quartz. This is consistent with earlier reports which suggest that dust-induced

hemolysis and lipid peroxidation proceed via independent mechanisms.^{15,16} Thus the hypothesis⁵ that lipid peroxidation caused by free radicals on the silica surface might be directly involved in the erythrocyte membrane damage does not seem likely. However, these radicals might be directly or indirectly involved in an oxidative-type chain reaction leading to macrophage membrane perturbation through lipid peroxidation and eventual fibrosis as noted earlier.^{2,6,7} It is interesting to note that fibrotic action, as a result of failed phagocytosis, was suggested to be due to the perturbation of macrophage membrane and the consequent release of a macrophage fibrotic factor.¹⁷ Recent ESR studies have shown that silica particles release $\cdot OH$ radicals in the presence of exogenous H_2O_2 ¹⁸ and even without it,⁷ and that the amount of the $\cdot OH$ radicals formed decreases with the "aging" of the quartz dust.^{6,7} Thus it is suggested that the $\cdot OH$ radical related mechanism of fibrogenesis by silica might be a fruitful new approach to understanding the pathogenesis of the silica-induced lung injury.

REFERENCES

1. Dalal, N.S., Suryan, M.M., Jafari, B., Shi, X., Vallyathan, V., Green, F.H.Y.: Electron Spin Resonance Detection of Reactive Free Radicals in Fresh Coal Dust and Quartz Dusts and Its Implications to Pneumoconiosis and Silicosis. *Proc. Int. Symp. on Respirable Dusts*

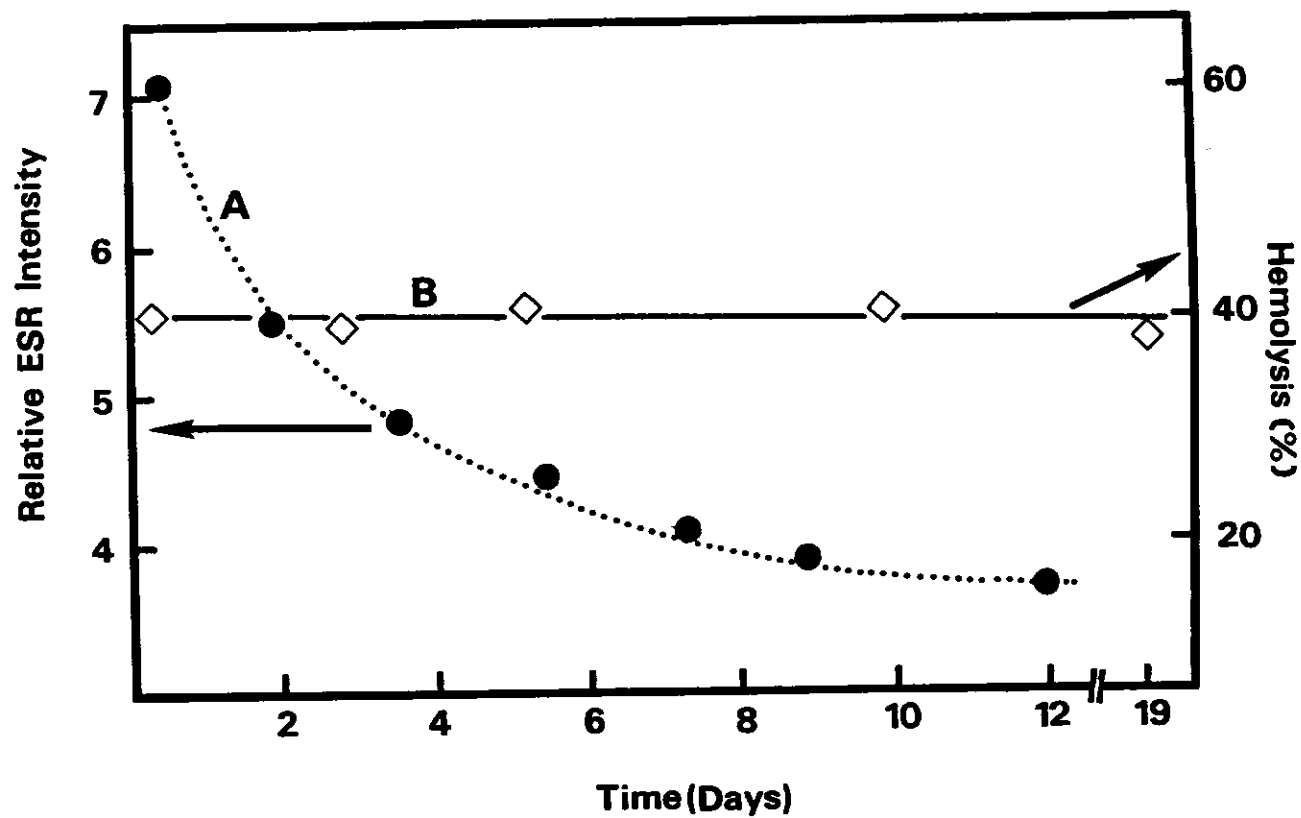

Figure 3. Time dependence of the ESR intensity of the silicon-oxygen radicals, plot A (●), on storing in air, and the hemolysis, plot B (◇), by the same sample.

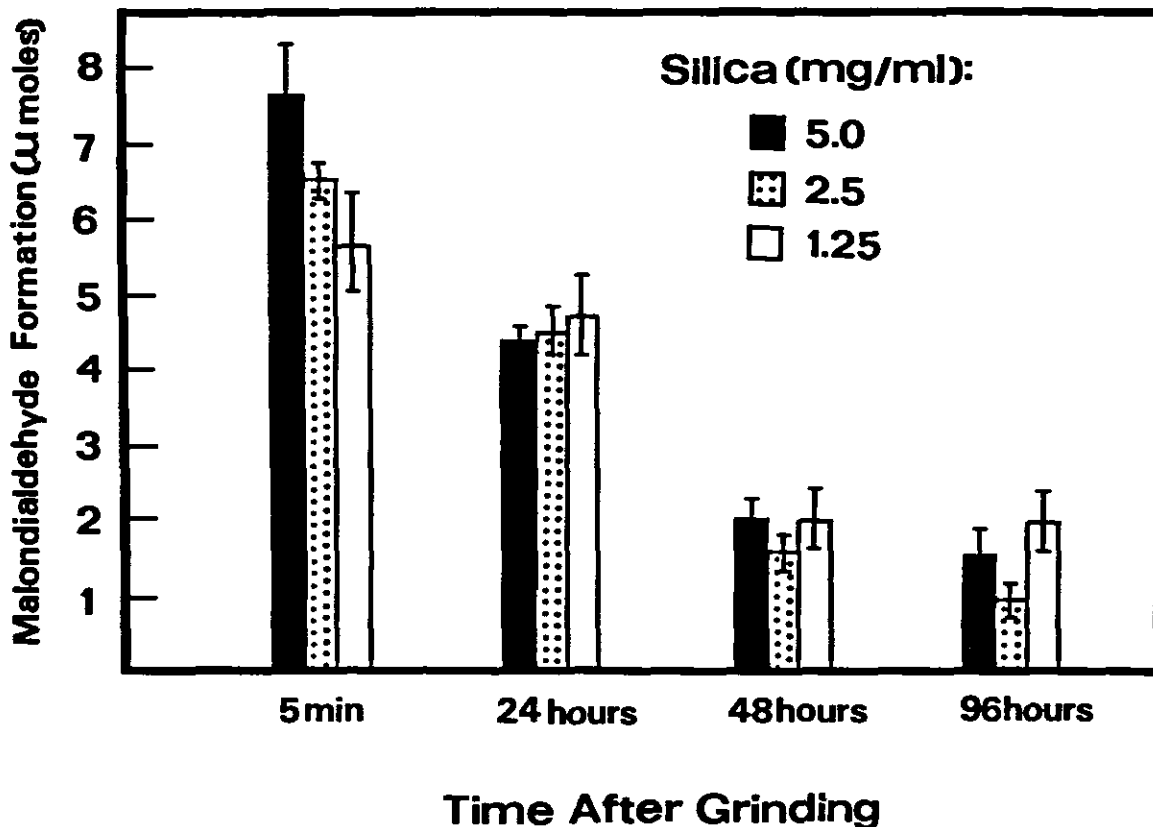

Figure 4. Effect of "aging" of the quartz dust on the rate of peroxidation of linoleic acid.

- in the Mineral Industries Pennsylvania State University, University Park, PA, USA. p. 24-29 (1986).
- Fubini, B., Bolis, V., Glamello, E.: The Surface Chemistry of Crushed Quartz Dust in Relation to Its Patogenicity. *Inorg. Chim. Acta* 138:193-197 (1987).
 - Hochstrasser, G., Antonini, J.F.: Surface States of Pristine Silica Surface. *Surface Sci.* 32:644-664 (1972).
 - Radtsig, V.A., Khalif, V.A.: Investigation of Gas Chemisorption Processes on the Surface of Finely Divided Quartz by ESR Spectroscopy and Microcalorimetry; *Kinet. Katal.* 20:705-713 (1979).
 - Gabor, S., Anca, Z.: Effect of Silica on Lipid Peroxidation in the Red Cells. *Int. Arch. Arbeitsmed.* 32:327-332 (1974).
 - Vallyathan, V., Shi, X., Dalal, N.S., Irr, W., Castranova, V.: Silicon-Oxygen Radicals and Their Role in Acute Silicosis (Abstract). *Am. Rev. Respir. Dis.* 137 (Suppl.):404 (1988).
 - (a) Dalal, N.S., Shi, X., Vallyathan, V.: Detection of Hydroxyl Radicals in Aqueous Suspensions of Fresh Silica Dust and Its Implication to Lipid Peroxidation in Silicosis. Paper presented at this conference (abstract No. 266). (b) Shi, X., Dalal, N.S., Vallyathan, V.: ESR Evidence for the Hydroxyl Radical Formation in Aqueous Suspension of Quartz Particles and Its Possible Significance to Lipid Peroxidation in Silicosis. *J. Toxicol. Environ. Health.* 25:000-000 (1988) (in press).
 - Nolan, R.P., Langer, A.M., Harington, J.S., Oster, G., Selikoff, I.J.: Quartz Hemolysis as Related to Its Surface Functionalities. *Environ. Res.* 26:503-520 (1981).
 - Harington, J.S., Miller, K., McNab, G.: Hemolysis by Asbestos. *Environ. Res.* 4:95-117 (1971).
 - Fraga, C.G., Leibovitz, B.Z., Tappel, A.C.: Halogenated Compounds as Inducers of Lipid Peroxidation in Tissue Slices. *J. Free Radical Biol. and Med.* 3:119-123 (1987).
 - Peri, J.B.: Infrared Study of OH and NH₂ groups on the Surface of a Dry Silica Areogel. *J. Phys. Chem.* 70:2937-2945 (1966).
 - Tsuchiya, I.: Infrared Spectroscopic Study of Hydroxyl Groups on Silica Surfaces. *J. Phys. Chem.* 82:4107-4112 (1982).
 - Raask, E., Schilling, C.J.: Research Finding on the Toxicity of Quartz Particles Relevant to Pulverized Fuel Ash; *Ann. Occup. Hyg.* 23:147-157 (1980).
 - Girotti, A.W.: Mechanism of Lipid Peroxidation; *J. Free Radical Biol. Med.* 1:87-95 (1985).
 - Kilroe-Smith, T.A.: Peroxidative Action of Quartz in Relation to Membrane Lysis. *Environ. Res.* 7:110-116 (1974).
 - Singh, S.V., Rahman, Q.: Interrelationship between Hemolysis and Lipid Peroxidation of Human Erythrocytes Induced by Silicic Acid and Silicate dusts. *J. Appl. Toxicol.* 12:91-96 (1987).
 - Pernis, B., Virginia, E.C.: The Role of Macrophages and Immunocytes in the Pathogenesis of Pulmonary Diseases due to mineral Dusts. *Am. J. Ind. Med.* 3:133 (1982).
 - Gulumian, M., Wyk, A.V.: Free Radical Scavenging Properties of Polyvinylpyridine N-Oxide: A Possible Mechanism for Its Action in Pneumoconiosis. *Med. Lav.* 78:124-128 (1987).

This research has been supported by the Department of the Interior's Mineral Institute program administered by the Bureau of Mines through the Generic Mineral Technology Center for respirable Dust under the grant number G1135142.

HISTOCOMPATIBILITY ANTIGENS IN A POPULATION-BASED SILICOSIS SERIES

K. KREISS • J. Danilovs* • L. Newman

National Jewish Center for Immunology and Respiratory Medicine

*University of Colorado School of Medicine, Denver, Colorado, USA

ABSTRACT

Individual susceptibility to silicosis is suggested by the lack of a uniform dose-response relation and by the presence of immunologic epiphenomena, such as increased antibody levels and associated diseases which reflect altered immune regulation. Human leukocyte antigens (HLA) are linked with immune response capability and might indicate possible genetic susceptibility to silicosis. We identified 49 silicotic subjects from chest radiographs in a population-based study in Leadville, CO. They were interviewed for symptoms and occupational history and gave a blood specimen for HLA-A, -B, -DR, and -DQ typing, as well as antinuclear antibody, immune complexes, immunoglobulins, and rheumatoid factor. Silicotic subjects had double the prevalence of B44 (45%) of the reference population and had triple the prevalence of A29 (20%), both of which were statistically significant when corrected for the number of comparisons made. Notably, no perturbations in D-region antigen frequencies were detected, B44-positive subjects were older at diagnosis and had less dyspnea than other subjects. A29-positive subjects were more likely to have abnormal levels of IgA and had higher levels of immune complexes. This study is the first to find significant HLA antigen excesses among a series of silicotic cases and extends earlier hypotheses in the literature which were based on groups of antigens of which B44 and A29 are components. The prognostic or screening value of HLA typing in silica-exposed workers requires further evaluation and confirmation in other population-based studies.

No Paper provided.

HARDROCK MINING EXPOSURES AFFECT SMOKERS AND NONSMOKERS DIFFERENTLY: RESULTS OF A COMMUNITY PREVALENCE STUDY

K. KREISS • L. Greenberg • S. Kogut • D. Lezotte* • C. Irvin • R. Cherniack

National Jewish Center for Immunology and Respiratory Medicine

*University of Colorado School of Medicine, Denver, Colorado, USA

ABSTRACT

The physiologic consequences of occupational dust exposure, their relation to smoking, and their reversibility with cessation of exposure remain controversial. To address these questions, we studied a random sample of male residents of Leadville, CO, when the major employer, a hardrock mine, had been closed for 5–11 months. Subjects were interviewed for respiratory symptoms and occupational history, underwent plethysmographic measurements of lung volume and airflow, and performed a single-breath diffusing capacity procedure. Dyspnea was the only respiratory symptom exacerbated by mining exposures. Cumulative dust exposure, estimated with historical respirable dust measurements for mining job titles, weighted by time at the job, was associated with decreases in maximal expiratory flow rates, when controlled for smoking, age, and height. However, determinations of plethysmographic lung volume which allowed calculation of isovolume flow rates indicated that dust effects differed in never-smokers and smokers. In never-smokers, dust exposure was associated with decreased lung volume, increased flow rates, and increased $DLCO/V_A$. In smokers, dust exposure was associated with increased lung volume, lower flow rates, and lower $DLCO/V_A$, than that accounted for by smoking. We suggest that hardrock mining exposures result in irreversible pulmonary function changes of airflow limitation in smokers and of a restrictive nature in never-smokers.

No Paper provided.

BLOOD LYMPHOCYTE RESPONSE TO BERYLLIUM AS A WORKPLACE SCREENING TEST FOR SUBCLINICAL BERYLLIUM DISEASE

K. KREISS • L. Newman • M. Mroz • P. Campbell

National Jewish Center for Immunology and Respiratory Medicine
Denver, Colorado, USA

ABSTRACT

Patients with chronic beryllium disease have peripheral blood and lung lymphocytes which undergo blast transformation in response to beryllium salts. We have evaluated the beryllium-specific lymphocyte transformation test (LTT) as a workplace screening tool for early beryllium disease. Fifty-one workers (88 percent of those with current beryllium exposure) completed questionnaires and gave blood specimens for LTT. Their chest radiographs were reviewed by a NIOSH-certified B reader. Twenty workers gave repeat blood specimens within one month for assessment of test reproducibility ($r=0.98$, coefficient of variation 21%). No persons changed LTT classification as either normal (2.6-fold stimulation index) or abnormal. Six of 51 workers (11.8%) had elevated LTT results, ranging from 5.7 to 16.7-fold stimulation. Four of five abnormal cases undergoing clinical evaluation had beryllium disease, demonstrated by granulomata on transbronchial lung biopsy and elevated LTT by bronchoalveolar lavage fluid cells (ranging from 18.6 to 44.3-fold stimulation). These data show that 1) minimally symptomatic cases of beryllium disease can be identified by this peripheral blood test; 2) not all beryllium-sensitized persons have beryllium disease at the time of their positive peripheral blood test; and 3) LTT reproducibility is good, justifying further evaluation of this test for screening. We conclude that the peripheral blood LTT may prove useful in preventing clinical chronic beryllium disease by early diagnosis in a subclinical phase.

No Paper provided.

MODIFIED NUCLEOSIDES IN ASBESTOS INSULATION WORKERS AT HIGH NEOPLASTIC RISK

A. FISCHBEIN • O. K. Sharma • F. Buschman • S. Solomon • I. J. Selikoff

Mount Sinai School of Medicine, New York, New York and
AMC Cancer Research Center and Hospital, Denver, Colorado, USA

ABSTRACT

Occupational exposure to airborne asbestos is associated with increased neoplastic risk. A latency period of 20–40 years between first onset of exposure and clinical manifestation of malignant disease is usually present.

Patients with certain cancers, including those with malignant mesothelioma, excrete high levels of modified nucleosides (transfer RNA breakdown products) in their urine.

In an attempt to investigate the usefulness of measuring such cancer markers in a population at high neoplastic risk, we have examined 1000 asbestos insulation workers with long-term exposure to asbestos but with no clinical evidence of malignancy at the time of examination.

A high prevalence of abnormal excretion patterns of several nucleosides, such as pseudouridine, 1-methyladenosine and 1-methylguanosine was found among the high-risk population as compared to a control group.

The results suggest that measuring levels of these biochemical markers among asbestos exposed workers, and perhaps others exposed to carcinogenic agents, has the potential for identifying, through multivariate statistical techniques, individuals who are at high neoplastic risk.

No Paper provided.

CHEST RADIOGRAPHIC AND CLINICAL FINDINGS AMONG IRONWORKERS AND MILLWRIGHT AND MACHINERY ERECTORS

A. FISCHBEIN • S. Rosenfeld • A. Rosenbaum • M. Corsey • S. Solomon

Mount Sinai School of Medicine and the Mount Sinai Hospital, New York, New York, USA

ABSTRACT

Asbestos associated diseases are prevalent in the construction trades primarily as a result of the use of asbestos containing insulation materials. Workers in metal related trades, employed at construction sites and power facilities, but not routinely using such materials, may also be at risk for asbestos hazards.

In order to assess such risk, a cross-sectional investigation was conducted of 867 ironworkers and 111 millwright and machinery erectors from the New York metropolitan area.

A high similar prevalence of roentgenologic abnormalities was found in both groups.

Forty three percent of the millwright and machinery erectors had pleural abnormalities. Duration from onset of employment was significantly longer for those with pleural abnormalities (mean 33 years) as compared to those with normal findings (mean 18 years). Ten percent had signs of interstitial lung disease. Correlations between roentgenologic and clinical findings will be presented. These findings demonstrate that individuals employed in trades with indirect exposure to airborne asbestos may be at high risk of adverse effects from such exposure.

No Paper provided.

INTER-READER VARIABILITY AMONG READERS USING ILO 1971 AND 1980 CLASSIFICATIONS OF THE PNEUMOCONIOSES

R. B. ALTHOUSE, M.S., B.S. • M. D. Attfield, Ph.D., B.Sc., F.S.S. • T. K. Hodous, M.D.

National Institute for Occupational Safety and Health, Morgantown, West Virginia

INTRODUCTION

The Coal Workers' X-ray Surveillance Program is a program mandated by the Occupational Safety and Health Act of 1969, which provides the opportunity for every working underground coal miner to have a chest radiograph taken at least once every five years.¹ One major objective of the program is to notify miners that their chest X-rays show signs of coal workers' pneumoconiosis (CWP), thereby allowing them the right to transfer to a low dust work environment. Broader objectives under the program provide for X-ray of all newly hired miners. Every participating miner is notified in writing of his X-ray status. The program is administered by NIOSH, Morgantown, WV.

Since the program inception in 1970, over 250,000 films have been processed. A diagram of the processing scheme is presented in Figure 1. Focusing on the X-ray processing scheme, it should be noted that a first reading is done at a facility close to the coal mine, usually by an 'A' reader. The films are then sent to NIOSH and distributed to 'B' readers selected on the basis of a randomized computer program. Thus all second readings are done by 'B' readers. The two results are summarized by a computer algorithm. If no consensus occurs, a third reading is requested from a 'B' reader. In order to become an 'A' reader, a person is required to correctly classify six X-rays from his/her own file, based on agreement with an expert panel. To become certified as a 'B' reader an examination given by NIOSH must be passed.

Reader variability between and within 'A' and 'B' readers has been an issue of concern since it reflects on the accuracy and consistency of data used for the transfer option, and on the perception of the program held by coal miners. In addition, it affects the ability to evaluate radiographic changes in individual coal miners, as well as overall estimates of prevalence and incidence over time.

Attfield documented inter-reader variability between and among 'A' and 'B' readers in a study in 1984.² The study was motivated by concerns brought to the attention of NIOSH, that first readings might be biased toward reading less abnormality since the choice of facility, and thus film reader, was made by the coal company. Findings of his study indicated that first readers, in fact, read higher levels of abnormality than second readers, but of more importance to this analysis, the study revealed high levels of variability, both between and among 'A' and 'B' readers.

The chest X-rays reviewed by the Attfield study were taken in the CWXSP between 1978 and 1981. These films were classified using the 1971 ILO classification scheme.³ During 1981 the use of the 1980 ILO classification was introduced into the program.⁴ The change in classification required film readers to assess the overall profusion as well as the type of opacities in a different manner. Figure 2 presents an extracted section from each classification related to opacity type and profusion. In the 1971 scheme each reader assessed separately, and in a sequential manner the profusion of rounded, irregular, and combined opacities. The 1980 scheme requires the reader to specify the overall profusion, and then designate which opacity type, rounded or irregular, appears dominant.

This analysis was undertaken to determine if the change in classification affected the levels of reader variability noted previously. In order to do this, readings of chest X-rays evaluated by first and second readers on the 1980 ILO classification of the pneumoconioses, were compared to those read in the Attfield study. Comparisons between first and second readers for each classification were made for the profusion of opacities read, the types of opacities read, and within each reader group, for the range of prevalence of abnormal opacities which they reported.

METHODS

X-rays of readable quality for miners with 10 or more years of underground mining tenure were selected from films read during 1981-1987, by the 1980 ILO classification. These restrictions led to selection of a sample of 10,249 X-rays comparable to the 14,886 read during 1978-1981 by the 1971 classification. The tenure restriction of ten years eliminates the large weighting toward normal readers seen in miners with less than 10 years tenure. Only the first and second reading were considered for each film. General variability between and among first and second readers under each classification were compared in three ways:

1. Agreement based on profusion of small opacities for all first and second readers in each ILO group.
2. Agreement based on type of small opacities for all first and second readers in each group.
3. Range of variation within each group of readers based on prevalence of opacities, determined by the difference in highest and lowest ranked readers.

A. EXAMINATION SCHEDULE

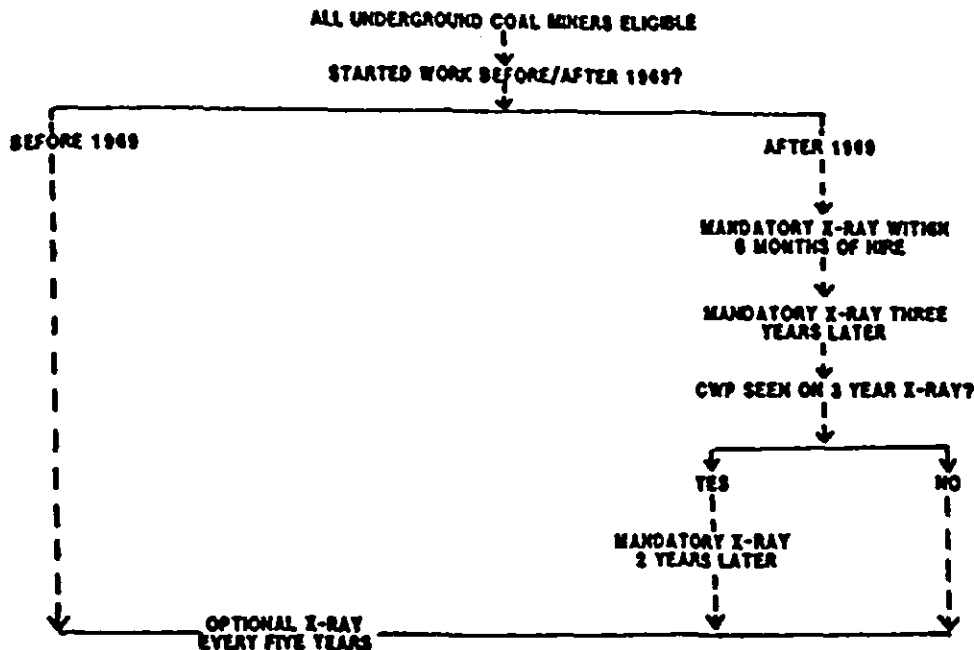

B. X-RAY PROCESSING

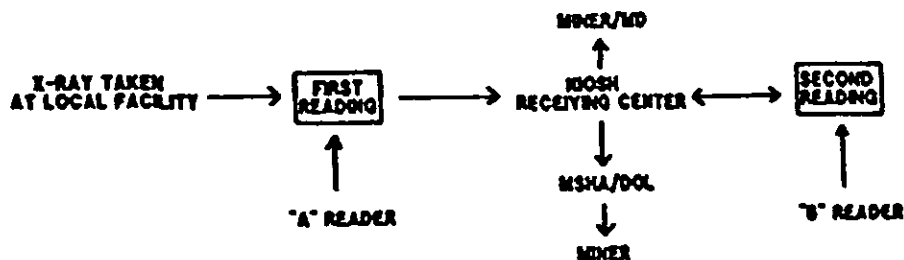

Broad processing scheme for X-rays in the CWXSP.

Tabulation of small opacities was based on the 12 point scale, ranging from category 0/- to 3/+. In all cases 0/- was combined with 0/0. These were combined to a 4 point major category scale in some cases. Prevalence comparisons were based on profusion of opacities, category 0/1 or greater.

Agreement was computed using the simple crude percentage. Since it seems reasonable to expect that the simple agreement of readings on the same films would be influenced by the underlying distribution of films, the kappa statistic⁵ was used to adjust for the amount of agreement one would expect simply by chance. Kappa represents the excess agreement, having adjusted for expected chance agreement. It is computed as:

$$\text{kappa} = \frac{\text{PC} - \text{PE}}{1 - \text{PE}}$$

where PC is crude agreement, PE is expected agreement, derived from marginal computations as in the chi-square test. A value of 0 represents no agreement, other than chance, while a value of 1 represents complete agreement.

For comparison of the two classification systems, the readings from the 1971 ILO were converted to a similar format to the 1980 ILO. A more detailed description is given elsewhere in these proceedings.⁶ Briefly, for PRIMARY TYPE, if profusions for both rounded and irregular opacities were recorded by the 1971 ILO:

1. The larger of the two profusions was taken as the single profusion and the PRIMARY type was set to the type with the larger profusion.
2. If profusions were equal for each type the PRIMARY type was randomly assigned.

1971 Classification of Small Opacities

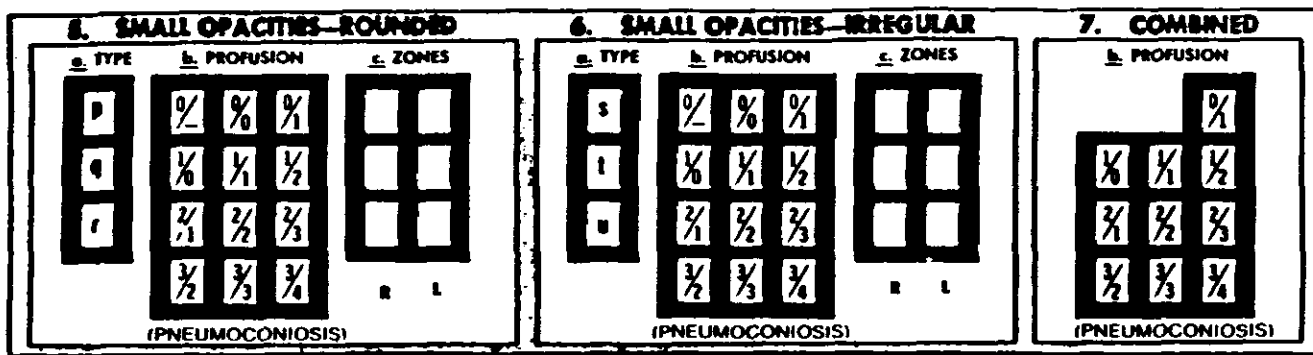

1980 Classification of Small Opacities

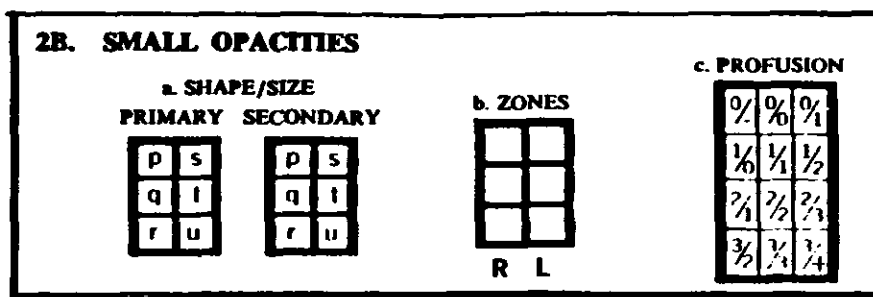

Figure 2

For the above situation SECONDARY TYPE was assigned as follows:

1. The SECONDARY type was set to the smaller of the profusion types.
2. The SECONDARY type was assigned the type not assigned to PRIMARY where profusions were equal.

If only one profusion type was recorded, that profusion was assigned to both PRIMARY and SECONDARY type.

RESULTS

Profusion of Opacities

Tabulations from the 1980 ILO group showed that 188 first readers and 20 second readers participated in evaluating the 10,249 X-rays. These values are close to the reported 196 first readers for the 1971 ILO, but indicate a decrease of 39% from the 33 second readers reported. Under 1980 ILO classification both first and second readers reported lower prevalence of category 0/1+ CWP, 12% for first and 4%

for second readers. By the 1971 ILO classification scheme these values were 27% and 22% respectively. The lower prevalences under the 1980 ILO may be a reflection of an actual decrease in CWP, however, the differences between first and second readings shows a slight increase from 5% to 8% between the classification schemes. Figure 3 displays agreement between first and second readers further broken down into categories of the 12 point scale. Increases in reader agreement are seen in category 0/0 from 93 to 97% and in category 0/1 from 91 to 98%. Using the 1980 scheme decreases in agreement were evident in categories 1/0 and 1/2, from 30 to 27% and 30 to 16% respectively.

The agreement between first and second readers on the same films are presented in Table I. Overall crude agreement within major categories increased from 78% to 87% from the 1978 to the 1980 group. This overall increase is most likely due to the higher proportion of normal X-rays seen in the 1980 group. However the kappa statistic which adjusts for chance agreement is virtually unchanged. Further-

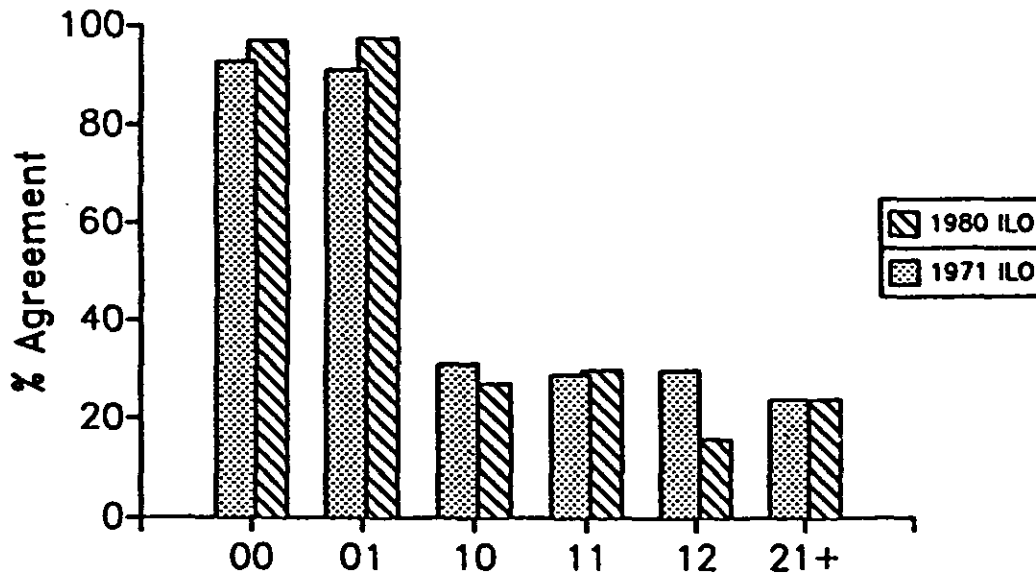

Figure 3. Agreement in profusion between reader 1 and reader 2 by minor category (agreement \pm 1 minor category).

Table I
Agreement between 1st and 2nd Readers within Major Categories

1971 ILO		Reader 2			
		CAT 0	CAT 1	CAT 2+	TOTAL
Reader 1	CAT 0	10,793	927	30	11,750
	CAT 1	1,705	690	105	2,500
	CAT 2+	215	192	229	636
TOTAL		12,713	1,809	364	14,886

1980 ILO		Reader 2			
		CAT 0	CAT 1	CAT 2+	TOTAL
Reader 1	CAT 0	8,669	336	9	9,014
	CAT 1	757	251	24	1,032
	CAT 2+	82	56	65	203
TOTAL		9,508	643	98	10,249

(10+ years mining experience required.)

PC = 78%
PE = 69.6%
Kappa = .29

PC = 87%
PE = 82%
Kappa = .28

more the bias toward higher readings by first readers seen in the results using the 1971 ILO scheme continues to be seen. In the earlier study, 15% of readings classified as category 0 by the first readers were classified as category 1 or more by the second reader, while 8% of films classified as category 0 by the second reader were classified as category 1 or more by the first reader. This results in a 7% bias towards higher readings compared to the first readers. A similar calculation of findings from the 1980 classification group shows the bias reduced slightly to 5%. Both groupings show higher values in the lower diagonal elements than the comparable upper diagonal cells indicating that the change in classification scheme has not altered the tendency of first readers toward higher readings.

Type of Opacities

The agreement between readers in reading opacity type showed some parallel to profusion readings. On both classifications, first readers reported higher levels of rounded opacities as a percentage of all opacities than second readers, for primary type. The percentage for first readers increased slightly, from 74% to 75%, while that for second readers decreased from 63% to 56%. The difference in percentage between first and second readers showed a roughly 1.5 fold increase. A further breakdown into types of small opacities shown in Table II indicates that the change is due mostly to a shift in the second readers toward reading fewer rounded and more irregular type opacities. Under both classification schemes first readers read the same percentages of rounded and irregular opacities, 74 and 26 percent respectively, although under the 1980 scheme a shift is seen towards reading more 's' and fewer 't' type irregular opacities. Second readers showed a much different pattern, with a large shift from fewer 'p' type rounded to more 't' type irregular opacities. This shift appears due to temporal changes in reading levels of rounded opacity types which have been occurring since 1978, discussed in more detail in Attfield, et al.,⁶ rather than a change due specifically to the ILO classification scheme. The major point is that regardless of the underlying trends, the variability between first and sec-

ond readers in the reporting of opacity types has not diminished under the 1980 ILO classification, but in fact has increased, compared to readings under the 1971 ILO scheme.

Table III presents data related to the final question, the range of variability among first and second readers. There was an overall decline in variability from 94% and 58% under the 1971 ILO to 68% and 31% under the 1980 ILO classification for first and second readers respectively. These reductions may in fact reflect actual levels of decrease in CWP, but the important element here is that first readers continue to read a range of disease at least twofold that of second readers.

DISCUSSION

The issue of variability in X-ray readings has implications, both as it relates to the CWXSP and to film readings in other research areas. In the CWXSP, the reduction of reader variability is of ongoing importance. One might expect that the change from the 1971 to the 1980 classification, given the focus on an overall evaluation of profusion of opacities, followed by a determination of primary and secondary opacity types, would increase agreement in readings between first and second readers.

Our findings indicate that this has not occurred. In summary, we found that first readers continue to read higher levels of prevalence of category 0/1+ opacities than second readers. The differences have increased rather than diminished. Reader agreement under the 1980 classification has increased in categories 0/0 and 0/1 only, decreasing in categories 1/0 and 1/2. Furthermore variability related to readings of small opacity types has increased. Among readers who read 50 or more films under each classification, the range of prevalence read by first readers as compared to second remains unacceptably high.

CONCLUSION

The findings of this study similar to those of Attfield² in-

Table II
Types of Opacities Reported as Primary Type for First and Second Readers

OPACITY TYPE	CLASSIFICATION			
	1971 ILO		1980 ILO	
	RDR1 (%)	RDR2 (%)	RDR1 (%)	RDR2 (%)
p	50.6	25.4	42.3	9.2
q	20.9	34.2	31.0	37.9
r	2.6	3.3	1.1	2.6
Total	74.0	62.9	74.4	49.7
s	14.2	19.7	18.1	19.7
t	11.0	16.7	7.1	30.4
u	0.8	0.7	0.3	0.3
Total	26.0	37.1	25.5	50.3

Table III
Range of Prevalence Category 0/1+ among First and Second Readers

ILO Classification	First Reader	Second Reader
1971	1%-95%	3%-61%
1980	5%-68%	0%-31%

dicates that a quality control system is needed to minimize this problem in the CWXSP. This need exists in relation to both first and second readers. A system of feedback, notifying readers of their standing relative to all readers is one possibility. Specific details of the system could conceivably vary for 'A' and 'B' readers. A recently published paper documents unacceptably high reader variability in 'B' readers involved in asbestos medical surveillance.⁷ The successful solution to this problem in the CWXSP might well serve as a model for other medical surveillance programs in which X-ray readers participate.

REFERENCES

- Occupational Safety and Health Reporter: Health Standards for Underground Coal Mines (compilation of regulations 1970-1980). Bureau of National Affairs, Inc., Washington, DC., (1978).
- Attfield, M.D., Althouse, R.B., and Reger, R.B.: An Investigation of Inter-Reader Variability Among X-ray Readers Employed in the Underground Coal Mine Surveillance Program. *Annals of the American Conference of Govt. Industrial Hygienists*. Vol. 14:401-409 (1986).
- International Labour Office: ILO U/C International Classification of Radiographs of Pneumoconiosis, 1971. Geneva, ILO, 1972 (Occupational Safety and Health Series No. 22, revised).
- International Labour Office: International Classification of Radiographs of Pneumoconiosis, (revised edition, 1980). Geneva, ILO, 1980. (Occupational Safety and Health Series No. 22 (Rev. 80)).
- Fleiss, J.L.: *Statistical Methods for Rates and Proportions*, pp. 146-147. John Wiley and Sons, New York (1973).
- Attfield, M.D., Hodous, T.K., Althouse, R.B.: A Comparison of the Profusion and Type of Small Opacities Reported with the 1980 and 1971 ILO Classification Using Readings from the Coal Workers' X-ray Surveillance Program. In these proceedings.
- Ducatman, A.M., Yang, W.N., Forman, S.A.: 'B-Readers' and Asbestos Medical Surveillance. *Journal of Occupational Medicine* 30:8, pp. 644-647. (1988).

EPIDEMIOLOGICAL METHODS DESIGNED TO ASSESS CROSS-SECTIONALLY AND LONGITUDINALLY THE RESPIRATORY HEALTH OF WORKERS EXPOSED TO CERAMIC FIBERS

**J. LOCKEY • G. Lemasters • C. Rice • V. Hertzberg
• K. Hansen • K. Baumbartner • J. Wlot**

Department of Environmental Health, University of Cincinnati, Cincinnati, Ohio, USA

ABSTRACT

The purpose of this study is to evaluate the pulmonary health of workers occupationally exposed to refractory ceramic fibers (RCF) at seven facilities (three manufacturing sites) in North America. The primary objective is to conduct a 5-year longitudinal morbidity study of RCF exposed workers. Pulmonary symptomatology is being assessed through administration of the American Thoracic Society respiratory questionnaire. Pulmonary function changes are assessed through yearly administration of spirometry. RCF exposed workers receive chest radiographs every 3 years, interpreted independently by 3 certified "B" readers using the ILO Classification of Radiographs of the Pneumoconioses. A detailed occupational and environmental exposure questionnaire is administered to assess past and current occupational exposures and to develop an exposure profile. Occupational exposure is also assessed by examining historic industrial hygiene data and performing quarterly environmental sampling of each manufacturing site.

Included in this study are both former (n=668) and current (n=312) employees and an unexposed referent group. To date all current employees have been evaluated and a feasibility study is underway to evaluate referent populations. This paper will discuss the methodological framework of the study design. Issues to be discussed include cohort reconstruction, selection of an appropriate referent group, and the development, testing and reliability assessment of the occupational history questionnaire.

No Paper provided.

MALIGNANT PLEURAL MESOTHELIOMA IN MONFALCONE, ITALY

C. BIANCHI • A. Brollo • L. Ramani

Laboratory of Pathological Anatomy, Hospital of Monfalcone, Monfalcone, Italy

INTRODUCTION

The Trieste and Monfalcone shipyards, northeastern Italy, represents the most important shipbuilding installations in the Mediterranean area. A high incidence of asbestos-related pleural mesothelioma has been reported from the Trieste Province, the large majority of the patients having been exposed in the shipyard.^{2,3,9} At the Hospital of Monfalcone an investigation into pleural mesothelioma has been under way since October 1979.^{5,6,8} The Monfalcone Hospital serves as a small coastal area with a total population of about 60,000.

MATERIALS AND METHODS

Forty seven cases of malignant pleural mesothelioma were observed at the Monfalcone Hospital between October 1979 and March 1988. The diagnosis was based on (or confirmed by) necropsy findings in 37 cases. In a further 6 cases, mesothelioma was diagnosed on material obtained at pleurectomy. In the remaining cases the pathology diagnosis was performed on pleura needle biopsy specimens (2 cases), or by cytological examination of the pleural fluid (2 cases). Detailed lifetime occupational histories were obtained from the patients themselves or from their relatives by personal interviews. In 36 cases, seen at necropsy at our laboratory, the thoracic cavity was carefully examined for hyaline pleural plaques; these were classified into 3 classes: 1, mild; 2, moderate; and 3, severe. The small plaques (few centimeters in major diameter) were defined as class 1. Very large plaques, involving the major part of a hemithorax were classified as class 3. The intermediate conditions were labelled as class 2. In expressing the results, sometimes the terms small and large plaques are used, "small" corresponding to class 1, and "large" including classes 2 and 3. In necropsy cases isolation and quantitation of asbestos bodies were performed after chemical digestion of lung tissue.²⁴ Samples were obtained from the base of the right lung or from the left base, when the right was largely involved by the tumor.

RESULTS

The series included 40 men (age range 46–89 years) and 7 women (age range 48–89 years) (Table I).

The large majority of the male patients had been exposed to asbestos in the shipbuilding industry, Navy, Merchant Navy, and insulation (Tables II and III). Of the remaining three men, the first had been employed in the Monfalcone sodium carbonate factory, a workplace where asbestos exposure certainly occurred in the past;⁷ the second had been exposed to a joiner and welder in a repair workshop; the

third patient had worked for some years in a dye-house, where "fireproofed textile fabrics for naval furniture," were dyed. Of the women, five patients had been exposed to asbestos at home, having cleaned the work clothes of their relatives, employed in shipbuilding or in the chemical industry. One patient had a mixed (occupational and domestic) exposure. Concerning the woman with "negative" history, it should be noted that she had spent the first twenty years of her life in a coastal city; during that period she lived near a large dockyard.

The duration of the exposure to asbestos was generally over 20 years (Table IV); however some subjects had been exposed for shorter periods, one patient having worked as a painter in the shipyard for only a few months. Only 3 subjects had their first exposure after 1950 (Table V). The latency periods, defined as intervals between the presumable time of the first exposure to asbestos and the time of the diagnosis, ranged from 20 to 63 years (Table VI).

At necropsy the large majority of the patients showed hyaline pleural plaques (Table VII). Lung asbestos bodies ranged between 100 and about 10,000,000 per gram of dried tissue, with 21 subjects having more than 10,000 asbestos bodies/gram (Table VIII).

The most severe stigmata of asbestos exposure were found in the two insulators, the former of whom showed large pleural plaques and more than 4,000,000 asbestos bodies per gram of dried lung tissue; in the latter about 10,000,000 asbestos bodies/g were isolated and no plaques were seen. Of 25 shipyard workers seen at necropsy, 22 showed large pleural plaques; no plaques were observed in two subjects and small plaques in one. The majority of the shipyard workers, namely 12, showed asbestos body counts ranging between 10,000 and 100,000/g; higher amounts (100,000–1,000,000) were found in 6 cases, and figures less than 10,000 in 7. Some thousands of asbestos bodies/g were isolated in two sailors (4,000 and 7,000 respectively), the former with large and the latter with small pleural plaques. The textile industry worker showed 5,000 asbestos bodies/g and small plaques. Of 5 women with histories of domestic exposure, two showed large pleural plaques, and a further two small plaques. In this group, one patient had an unexpectedly high amount of asbestos bodies (90,000/g), the figures ranging between 100 and 6,000/g in the remaining cases. Finally the patient with "negative" history did not show pleural plaques; the amount of asbestos bodies in this case was 600/g.

The histological examination of lung tissues obtained at

Table I
Sex and Age Distribution in 47 Cases of Malignant Pleural Mesothelioma

Age (years)	Men	Women	Total
45 - 49	3	1	4
50 - 54	2	0	2
55 - 59	4	1	5
60 - 64	2	0	2
65 - 69	9	0	9
70 - 74	8	2	10
75 - 79	8	0	8
80 - 84	2	2	4
85 - 89	2	1	3
Total	40	7	47

Table II
Asbestos Exposures: Occupational Data

	No. of cases
MEN	
Shipbuilding industry	30
Navy and merchant navy	5
Insulation	2
Chemical industry	1
Construction industry	1
Textile industry	1
WOMEN	
Domestic exposure	5
Mixed exposure*	1
Negative history	1

* Occupational (shipyard) and domestic

Table III
Trades of the Shipyard Workers

	No. of cases		No. of cases
Painter	4	Calker	1
Plumber	4	Electrician	1
Shipwright	4	Laborers	1
Mechanic	3	Riveter	1
Carpenter	2	Sheet metal worker	1
Joiner	2	Various	2
Welder	2	Unknown	1
Worker	2		

Table IV
Duration of Asbestos Exposure

Years	Men	Women	Total
0 - 4	1	0	1
5 - 9	5	0	5
10 - 19	1	0	1
20 - 29	9	3	12
30 - 39	13	3	16
40 - 49	11	0	11
Total	40	6	46

Table V
First Exposure to Asbestos

Calendar years	Men	Women	Total
1920 - 1929	12	4	16
1930 - 1939	17	1	18
1940 - 1949	8	0	8
1950 - 1959	2	0	2
1960 - 1969	1	0	1
Undetermined	0	1	1
Total	40	6	46

Table VI
Latency Periods (First Exposure—Diagnosis)

Years	Men	Women	Total
20 - 29	3	0	3
30 - 39	3	0	3
40 - 49	13	0	13
50 - 59	16	4	20
60 - 69	5	1	6
Undetermined	0	1	1
Total	40	6	46

Table VII
Hyaline Pleural Plaques in 36 Necropsy Cases

Pleural Plaques	Men	Women	Total
Absent	3	2	5
Class 1	3	2	5
Class 2	5	1	6
Class 3	19	1	20
Total	30	6	36

Table VIII
Lung Asbestos Bodies in 36 Necropsy Cases

AB *	Men	Women	Total
2 - 3	0	2	2
3 - 4	10	3	13
4 - 5	12	1	13
5 - 6	6	0	6
6 - 7	2	0	2
Total	30	6	36

* Asbestos bodies, Log10/g dried tissue

necropsy revealed a variable degree of pulmonary asbestosis in 31 of 36 cases. Multiple tumors were observed in 7 necropsy cases. In particular three additional malignancies, beside mesothelioma, were found in a 77-year-old man: stomach adenocarcinoma, chronic lymphocytes leukemia, and prostate microelectronic. A further three men showed prostate microcarcinomas, and one man had chronic lymphocytes leukemia. Among women, NOS infiltrating breast carcinoma was associated with the mesothelioma in one case. Moreover another patient had been successfully treated for infiltrating breast carcinoma two years previously.

DISCUSSION

In the epidemiology of malignant mesothelioma more serious difficulties are encountered than in the generality of other malignancies.¹⁰ Recent investigations carried out in the U.S.A. show that the reliability of death certificates may be very scarce.^{11,18,23} On the other hand, the histological diagnosis itself is not always reliable, the percentages of diagnoses confirmed by panels of expert pathologists being sometimes very low.²⁵ At any rate the high incidence of malignant pleural mesothelioma in shipyard areas belongs to the category of the well established facts in the geography of mesothelioma^{3,9,11,12,16} The low numbers of meso-

theliomas in some shipbuilding countries of Eastern Asia such as Japan,²¹ Hong Kong,¹⁷ and Singapore,¹³ seem at variance with the above statement. However, it must be noted that in some of these regions industrialization is a recent process, so that a sufficient time may not have elapsed to allow the development of many mesotheliomas. Concerning Japan, certainly a long-established industrial power, the use of asbestos was minimum in this country until 1950, reaching important values only in the 1960's.²²

In the Monfalcone area, the relationship with shipbuilding represents the most important characteristic of pleural mesothelioma, working in the shipyard accounting for the large majority of the cases. The risk is not confined to few trades. On the contrary, among shipyard workers practically all the occupational categories are involved, a fact already well documented.³ In addition, "shipyard asbestos" is responsible for further cases, by inducing pollution of the domestic environment.

Asbestos exposure sufficient to induce the development of malignant mesothelioma may occur in a variety of workplaces, other than shipyards.^{3,8,9,12,14,15,19,20} Maritime trades emerge as important occupations at risk in the present as well as in other mesothelioma series.⁹ However, for

other occupations, the existence of a previous exposure to asbestos may be more difficult to determine. Some histories in the present series were judged as negative or uncertain at a first examination, and occupational asbestos exposure could be ascertained only by deeper inquiries. In fact the characteristics of a given workplace, as they were some forty-sixty years ago, are not simple to reconstruct, especially when this workplace is a small workshop. Obviously the objective data (pleural plaques, asbestos body amount, lung asbestosis) are of enormous importance in such a reconstruction.^{7,8}

The dangers related to the large use of asbestos in the industrial world have not been sufficiently appreciated.¹ The data collected in Monfalcone as well as in other Western shipyard areas, have serious implications. Shipyard mesothelioma represents a particular "enhanced model" of asbestos-related malignancy. It is presumable that the situation which occurred in Western shipyard areas in the past has been repeated, although to a lesser extent, in a variety of workplaces during the last decades. This means that an epidemic of mesotheliomas might involve all the industrial world in the coming years. If large numbers of persons have been seriously exposed to asbestos in recent years, then all the possibilities of preventing the development of mesothelioma in such people should be explored.^{4,5} In this context it is important that the mechanisms implied in the genesis of mesothelioma are clarified. In asbestos-related mesothelioma the main agent is well known. However, the other concurring factors, presumably playing some role in the genesis of the tumor, remain to be identified.^{4,5} The role of environmental coveters such as nitrosamines have been hypothesized. On the other hand host factors have to be considered, and immune impairment, favored by asbestos itself and/or induced by other causes could be of critical importance. Such aspects should be included among the main objectives of the future research on mesothelioma.

REFERENCES

- Berman, D.M.: Asbestos and Health in the Third World: The Case of Brazil. *Int. J. Health Serv.* 16:253-263 (1986).
- Bianchi, C., Di Bonito, L., Grandi, G., Furlan, L.: Esposizione lavorativa all'asbesto in 20 casi di mesotelioma diffuso della pleura. *Min. Med.* 64:1724-1727 (1973).
- Bianchi, C., Giarelli, L., Di Bonito, L., Grandi, G., Brollo, A., Bittesini, L.: Asbestos-Related Pleural Mesothelioma in the Trieste Area. *Advances in Pathology*, pp. 545-548. E. Levy, Ed., Pergamon Press, Oxford and New York (1982).
- Bianchi, C., Brollo, A., Bittesini, L.: Mesotelioma maligno: un'etiologia multifattoriale? *Riv. Inf. Mal. Prof.* 72:73-78 (1985).
- Bianchi, C., Brollo, A., Bittesini, L.: Malignant Mesothelioma of the Pleura in Monfalcone (Italy). *Epidemiologia in Oncologia*, pp 143-151. L. Caldarola, F. Pocchiari, F. Minardi, L. Pieri, G. Perino, C. Maltoni and D. Carretti, Eds., Monduzzi, Bologna (1986).
- Bianchi, C., Brollo, A., Bittesini, L., Ramani, L.: Asbestos-Related Pleural Mesothelioma in the Monfalcone Area (Italy). *Med. Lav.* 77:80 (1986).
- Bianchi, C., Brollo, A., Bittesini, L., Ramani, L.: Esposizione all'asbesto nel territorio di Monfalcone. *Riv. Inf. Mal. Prof.* 73:275-282 (1986).
- Bianchi, C., Brollo, A., Bittesini, L., Ramani, L.: Asbestos-Related Mesothelioma of the Pleura: What Occupations at Risk? *XIth World Congress on the Prevention of Occupational Accidents and Diseases. ISSA Specialized Meeting. Epidemiological Studies in the Occupational Environment, Results and Methods*, pp 11-16, Stockholm, Sweden (1987).
- Bianchi, C., Grandi, G., Di Bonito, L.: Malignant Mesothelioma of the Pleura in Trieste, Italy. *XXII International Congress on Occupational Health*, 331, Sidney, Australia (1987).
- Bianchi, C., Brollo, A., Bittesini, L., Ramani, L.: Geografia del mesotelioma. *Riv. Inf. Mal. Prof.* 74:655-662 (1987).
- Connelly, R. R., Spirtas, R., Myers, M. H., Percy, C. L., Fraumeni, J. F. Jr.: Demographic Patterns for Mesothelioma in the United States. *J.N.C.I.* 78:1053-1060 (1987).
- Ferguson, D. A., Berry, G., Jelihovsky, T., Andreas, S. B., Rogers, A. J., Fung, S. C., Grimwood, A., Thompson, R.: The Australian Mesothelioma Surveillance Program 1979-1985. *Med. J. Aust.* 147:166-172 (1987).
- Ho, S. F., Lee, H. P., Phoon, W. H.: Malignant Mesothelioma in Singapore. *Br. J. Ind. Med.* 44:788-789 (1987).
- Hunacharek, M., Capotorto, J.: Asbestos Related Lung Disease in Maintenance Workers. *Br. J. Ind. Med.* 45:203-204 (1988).
- Jarvholm, B., Malker, H., Malker, B., Ericsson, J., Sallsten, G.: Pleural Mesotheliomas and Asbestos Exposure in the Pulp and Paper Industries: A New Risk Group Identified by Linkage of Official Registers. *Am. J. Ind. Med.* 13:561-567 (1988).
- Jones, R.D., Smith, D.M., Thomas, P.G.: Mesothelioma in Great Britain in 1968-1983. *Scand. J. Work Environ. Health* 14:145-152 (1988).
- Lam, W.K., Kung, T.M., Ma, P.L., So, S.Y., Mok, C.K.: First Report of Asbestos-Related Diseases in Hong Kong. *Trop. geogr. Med.* 35:225-229 (1983).
- Lilienfeld, D.E., Gunderson, P.D.: The "Missing Cases" of Pleural Malignant Mesothelioma in Minnesota, 1979-81: Preliminary Report. *Public Health Rep.* 101:395-399 (1986).
- Mancuso, T.F.: Relative Risk of Mesothelioma Among Railroad Machinists Exposed to Chrysotile. *Am. J. Ind. Med.* 13:639-657 (1988).
- Michaels, D., Zoloth, S.: Asbestos Disease in Sheet Metal Workers: Proportional Mortality Update. *Am. J. Ind. Med.* 13:731-734 (1988).
- Morinaga, K., Hara, I., Yutani, S., Sera, Y.: Uses of Population-Based Cancer Registration in Occupational Epidemiology: Experience in Osaka. *J. UOEH* 5 (Suppl.):215-223 (1983).
- Morinaga, K., Yokoyama, K., Yamamoto, S., Matsuda, Y., Sera, V.: Mortality and Survival of Workers Receiving Compensation for Asbestosis in Osaka, Japan. *VIIth International Pneumoconiosis Conference*, 2nd Vol., pp. 768-774, Bochum, West Germany (1983).
- Nelson, D.E., Swanson, G.M., Grossbart Schwartz, A., Brix, K., Fine, L.J.: Occupational and Industry Data Obtained from Death Certificates: The Effect and Influence of Case Selection. *J. Occup. Med.* 29:52-56 (1987).
- Smith, M.J., Naylor, B.: A Method for Extracting Ferruginous Bodies from Sputum and Pulmonary Tissue. *Am. J. Clin. Pathol.* 58:250-254 (1972).
- Spirtas, R., et al.: Recent Trends in Mesothelioma Incidence in the United States. *Am. J. Ind. Med.* 9:397-407 (1986).

ATMOSPHERIC PAH CONCENTRATIONS DURING CHIMNEY SWEEPING

U. KNECHT • H.-J. Woitowitz

Institute of Occupational Medicine, Giessen, FRG

ABSTRACT

Epidemiological investigations have confirmed the cancer risk to chimney sweeps as a result of their exposure to soot and tar whilst at work. These complex mixtures of substances, which are pyrolysis products of organic materials, contain, amongst other things, carcinogenic polycyclic aromatic hydrocarbons (PAH). In order to be able to estimate the health risk both air sampled from that inhaled by chimney sweeps during the "dirty work" and soot samples were analyzed for PAH. The air sampling at the chimney only included the cleaning process and excluded periods without dangerous expositions.

A total of 20 PAH were quantified by gas chromatography-mass spectrometry in the n=115 air samples and n=18 soot samples. These included benzo[b]fluoranthene, benzo[a]pyrene (BaP), chrysene, dibenz[a,h]anthracene and ideno[1,2,3-cd]pyrene, all of which have been unequivocally confirmed to be carcinogenic in animal experiments. The summed atmospheric concentration of these compounds depended on the type of fuel employed and averaged 2.27 $\mu\text{g}/\text{m}^3$ for oil fuel. If a mixture of oil and solid fuel was employed the concentration was 5.06 $\mu\text{g}/\text{m}^3$ and pure solid fuel heating yielded 5.08 $\mu\text{g}/\text{m}^3$. The air concentrations of BaP were 0.36, 0.83 and 0.82 $\mu\text{g}/\text{m}^3$ respectively. The soot samples recovered after employment of the three different fuel types were 10.50, 109.10 and 51.25 mg/kg BaP. The maximum total concentrations of the five carcinogenic PAH were 243.70, 691.06 and 213.94 mg/kg respectively.

The time-weighted, shift mean concentrations of 0.02 to 0.21 $\mu\text{g}/\text{m}^3$ benzo[a]pyrene obtained on 11 days form the basis for the industrial-medical estimation of risk.

No Paper provided.

ROLE OF MAST CELLS IN THE PATHOGENESIS OF SILICOSIS

HEIDRÜN BEHRENDT • R. Ziesche • P. Stutz* • Helga Idel
• K. H. Friedrichs • W. Hilshcher • H. Magnussen*

Medical Institute of Environmental Hygiene at the University, Auf'm Hennekamp 50, D-4000 Düsseldorf, FRG and
*Centre of Pneumology and Thoracic Surgery at the LVA-Hospital, D-2070 Großhansdorf, FRG

INTRODUCTION

Mast cells are bone marrow derived mononuclear cells containing vasoactive amines, proteoglycans and proteases within their specific granules. Under pathological conditions, mast cells play a central role in allergic inflammatory processes as well as in parasitic diseases, both in human and in animal individuals. Increased numbers of mast cells also occur under non-allergic conditions,⁶ i.e. in inflammatory diseases of the intestine, rheumatoid synovitis, and fibrotic disorders of the skin, the lung and the nervous system. With respect to the lung, elevated levels of mast cells can be obtained by bronchoalveolar lavage in asthmatic patients^{12,17} and in patients with various fibrotic lung disorders,^{5,13} including silicosis.⁶

The role of mast cells in silicosis is not well understood. We therefore investigated the effects of silica dust DQ 12 on rat mast cells *in vivo* and *in vitro*. In addition, we analyzed mast cell topography in transbronchial lung biopsies from three patients with anthracosilicosis.

MATERIAL AND METHODS

Silica Dust

Quartz dust DQ 12, particle size <5 µm, were used in all animal experiments. For the *in vitro*-studies a stem solution (100 µg/ml) in buffer (Hanks balanced salt solution) have been prepared briefly before use, as described elsewhere.²⁰ For intratracheal instillation quartz dust DQ 12 has been suspended in sterile 0.9% saline. The inhalation experiments have been performed using native quartz dust.

Animals

Female Lewis rats, 8 weeks old, SPF-state, were used throughout all experiments, if not otherwise stated.

In-vitro Experiments

Rat peritoneal cells containing about 16 percent of mast cells²⁰ were harvested according to the method of Uvnäs and Thon.¹⁸ Triplicate samples of 10⁶ cells per ml buffer were then incubated (37°C, 10 to 120 minutes) with 3–100 µg/ml quartz DQ 12. The reaction was terminated by the addition of icecold buffer. For light microscopical investigations cytocentrifuge preparations have been performed. The cells were fixed in formaline vapour and subsequently stained with the combined alcianblue-safranin sequence.

For electron microscopy cells were fixed with glutaraldehyde, postfixed with osmium tetroxide, dehydrated

and embedded in Araldite. Ultrathin sections were investigated in a Philips 400T electron microscope.

Cell viability was determined by the use of the Eosin Y dye exclusion test.

Short-term Inhalation Experiments

Short-term inhalation experiments were performed in a chamber containing a rotating wheel, as described elsewhere.^{2,4} Groups of 5–6 rats were exposed to 10 mg quartz DQ 12 per cbm air, 6 hours a day, for up to 28 days. After termination of the experiment bronchoalveolar lavage (BAL) according to the method of Brain and Frank⁸ was undertaken. The BAL cells were either spun down in a cytocentrifuge followed by fixation and staining as indicated above, or processed for electron microscopical analysis.

A second group of animals were fixed by instillation of 2% buffered glutaraldehyde (10 cm H₂O, 20 minutes). After removal of total lungs, the right middle lobe was cut into small pieces. After postfixation, dehydration and embedding ultrathin sections were analyzed in the electron microscope.

For the determination of lung histamine content, from a third group of animals the left lung was removed; its wet weight was determined. It was then cut into small pieces, mechanically homogenized and resuspended in 2% perchloric acid. After sonification and centrifugation the supernatant was assayed for histamine, using the fluorimetric auto-analyzer technique. Histamine content was expressed as microgram per gram wet weight of the lung.

Intratracheal Instillation Experiments

Groups of 5 female Wistar rats, SPF state, were used in these experiments. The animals received a single dose of 40 mg of quartz DQ 12 in 0.5 ml saline by instillation. Control rats were instilled with saline only. After 8 weeks the lungs were fixed and prepared for light microscopical investigations. Mast cell analysis was performed under the light microscope. 8 µm sections were stained with alcianblue-safranin O and the number of mast cells was determined.

Statistics

For statistical analysis Student's t-test has been performed.

Patients

Transbronchial lung biopsies from three male patients with

anthracosilicosis were obtained by standardized procedures. All samples were then fixed and processed for electron microscopical investigations.

RESULTS

Effect of Quartz DQ 12 on Rat Mast Cells *In Vitro*

The cytotoxic effect of quartz DQ 12 on rat peritoneal cells is time- and dose-dependent (Figure 1). At concentrations where a substantial amount of cells are still viable (12.5 $\mu\text{g/ml}/10^6$ cells) quartz DQ 12 induces a stimulatory action.

Cell stimulation is proofed by the appearance of increased numbers of degranulated mast cells after incubation with low concentrations of quartz, but not at higher doses (Figure 2). During quartz-induced activation of mast cells a substantial amount of histamine is released into the incubation medium. Particle counts indicate that only 7 particles per cell (i.e. 12.5 $\mu\text{g/ml}/10^6$ cells) are responsible for cell stimulation, whereas 30 particles per cell (i.e. 50 $\mu\text{g/ml}/10^6$ cells) are already cytotoxic.²⁰

Electron microscopical investigations show partially degranu-

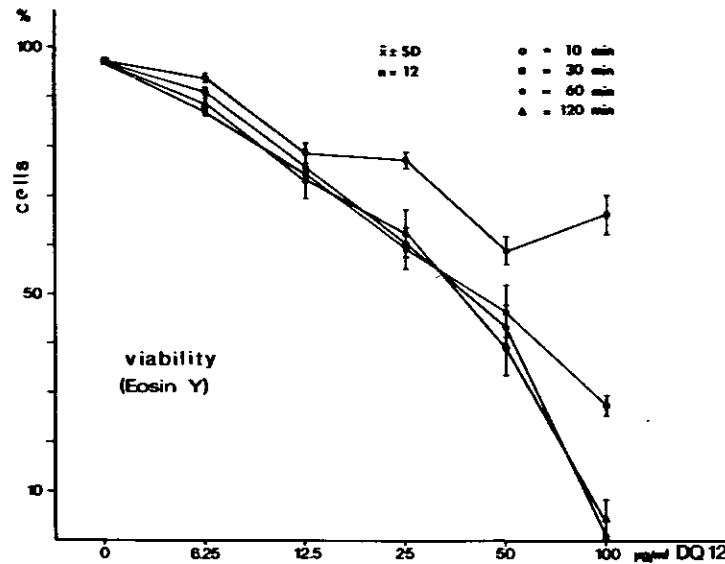

Figure 1. Dose- and time-dependent effect of quartz DQ 12 on the viability of rat peritoneal cells *in vitro*.

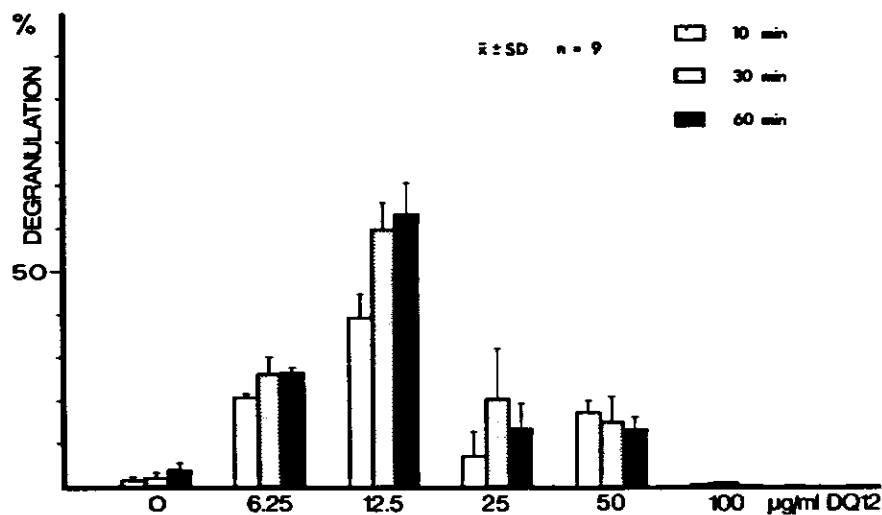

Figure 2. Dose- and time-dependent effect of quartz DQ 12 on the number of degranulated rat mast cells *in vitro*.

lated mast cells after incubation with low doses but not with high concentrations of quartz DQ 12 (Figure 3). Additionally, quartz-mediated mast cell/macrophage interactions are prominent, even under the conditions of the incubation method employed (shaking water bath). Phagocytosis of particles by mast cells could never be detected.

Effect of Short-term and Low Dose Inhalation of Quartz DQ 12 on Rat Lung Mast Cells

Early cellular events in rat lungs induced by quartz dust inhalation are characterized by an inflammatory response which has been described in detail elsewhere.^{2,3,4} With respect to lung mast cells, intraepithelial mast cells occur as early as after an inhalation period of 4 days,³ followed by the appearance of small numbers of mast cells in the bronchial lumen at day 8 and at day 14.⁴ In addition, lung histamine content is significantly reduced at day 8 and remains at lower levels during the whole inhalation period (Figure 4). No increase in the number of parenchymal mast cells could be detected.

Number and Topography of Mast Cells in Silicotic Rat Lungs after Intratracheal Instillation of Quartz Particles

Instillation of 40 mg quartz DQ 12 into the trachea of rats results in lung fibrosis after 8–12 weeks. Initiation of fibrosis is accompanied by an 68.5% increase in the number of mast cells. In addition to mast cell hyperplasia, about 50% of these cells are localized interstitially (Figure 5), indicating mast cell redistribution. Most of the mast cells display safranophilic granules. They therefore represent the connective tissue subtype, with respect to mast cell heterogeneity. Consequently, they are situated within bundles of collagen (Figure 6). Cells who are in close contact to fibroblasts display partial degranulation. Interactions between mast cells and dust-laden macrophages are frequently seen.

Occurrence of Mast Cells in Transbronchial Lung Biopsies Obtained from Silicotic Patients

Numerous mast cells are present in transbronchial lung

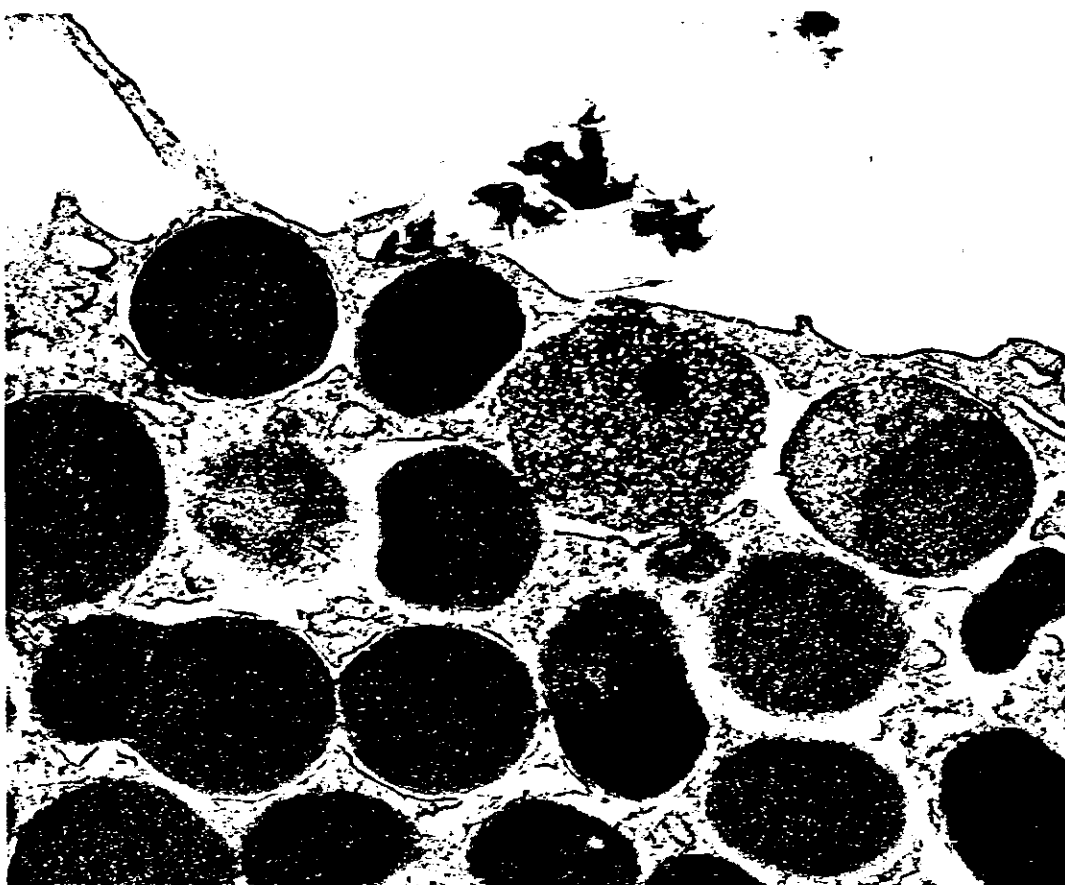

Figure 3. Electron micrograph of part of a mast cell undergoing degranulation induced by quartz DQ 12 *in vitro* (50 μ g quartz DQ 12; 10 min.) Magn. x39000.

biopsies from silicotic patients (Figure 7). The cells display the species-specific whorls and scrolls within their granules. Exocytotic figures indicating mast cell degranulation are

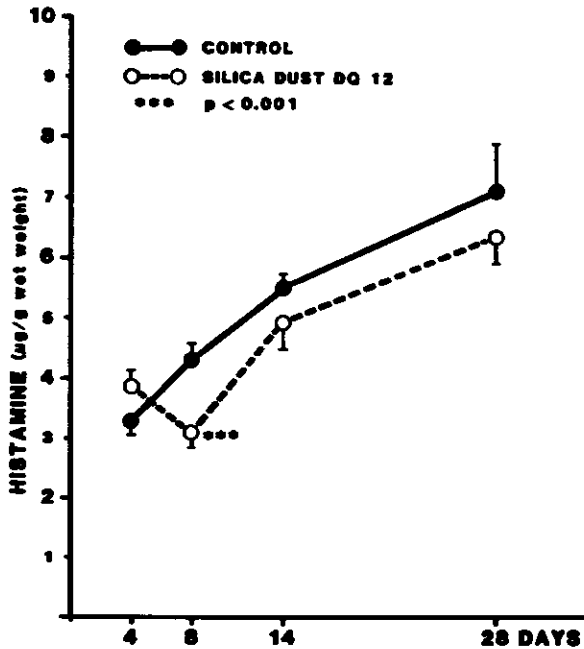

Figure 4. Effect of quartz dust inhalation (10 mg/cbm, 6 hrs per day) on total lung histamine content. Values are expressed as µg histamine per g wet weight of the lung.

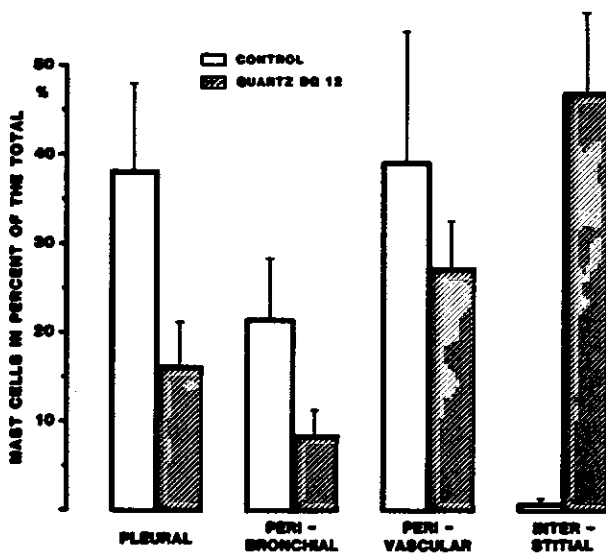

Figure 5. Distribution of mast cells in the rat lung 8 weeks after a single intratracheal dose (40 mg) of quartz DQ 12.

infrequently seen. If they occur they are always accompanied by fibroblast activation (Figure 8). Again, contacts between dust-laden macrophages and mast cells are visible (Figure 9). Examination of cells obtained by bronchoalveolar lavage reveal mast cells which are similar to cells seen in fibrotic lung areas and which are different from those obtained by bronchoalveolar lavage from asthmatic patients.⁵

DISCUSSION AND CONCLUSIONS

This paper describes the occurrence, topography and functional behaviour of lung mast cells in response to cytotoxic quartz particles. The results obtained show that mast cells participate in the generation of silicotic pulmonary fibrosis. As is evident from our *in vitro* and *in vivo* experiments in the rat, mast cells are clearly involved in both, the initial inflammatory process and in fibrogenesis. Since continuous inflammation is an important link between inhaled quartz particles and the development of fibrosis in the lung,⁷ mast cells are supposed to be one important element influencing and modulating this process. It is well known that mast cells release a variety of chemically active mediators of inflammation including diverse chemotactic factors upon appropriate stimuli.¹⁴ Macrophages have been reported to release products with histamine liberating activity¹⁶ as is true for oxygen radicals.¹¹ Histamine itself is able to potentiate the phagocytic activity of alveolar macrophages.¹⁰ For this functional interaction between mast cells and macrophages in the lung the morphological equivalent is demonstrated in this paper. The phenomenon is not only relevant in the pathogenesis of experimental silicosis but is also present in transbronchial lung biopsies from silicotic patients. Therefore, mast cell—macrophage cooperation seems to be a general mechanism involved in the pathogenesis of silicosis.

The role of mast cells within fibrotic lung areas is not well understood. Mast cells can activate fibroblasts to divide,¹⁵ and mast cell granules have been shown to affect fibroblast functions.¹ Fibroblasts in reverse are needed for the differentiation, development and granule synthesis of connective tissue mast cells.⁹ Additionally, mast cells are able to influence some extracellular components of the connective tissue itself.¹ Furthermore, mast cell hyperplasia has been reported to occur in lung parenchyma of chronically hypoxic rats.¹⁹ Therefore, mast cells can influence a variety of parameters which are necessary for and involved in fibrogenesis induced by toxic silica particles.

REFERENCES

- Atkins, F.M., Friedman, M.M., Subba Rao P.V., Metcalfe, D.D.: Interactions between mast cells, fibroblasts and connective tissue components. *Int. Archs. Allergy Appl. Immun.* 77:96-102 (1985).
- Behrendt, H., Friedrichs, K.H.: Effect of low dose and short time inhalation of silica dust on the morphology of rat lungs. *Aerosols: Formation and Reactivity*, 2nd Int. Aerosol Conf. Berlin, pp. 279-281, Pergamon Press (1986).
- Behrendt, H., Friedrichs, K.H.: Influence of quartz dust DQ 12 inhalation on early cellular reaction in the rat lung. II. Electron microscopical analysis of the lung parenchyma. *Silicosis Report North-Rhine Westfalia* Vol. 16:231-245 (1987).
- Behrendt, H., Friedrichs, K.H., Gentz, R., Kainka-Sünicke, E.: Influence of quartz dust DQ 12 inhalation on early cellular reaction in the rat lung. I. Electron microscopical analysis of the bronchoalveolar lavage cells. *Silicosis Report North-Rhine Westfalia* Vol. 16:217-230(1987).



Figure 6. Rat lung mast cell surrounded by bundles of collagen fibres 8 weeks after intratracheal application of 40 mg quartz DQ 12. Electron micrograph. Magn. x9000.

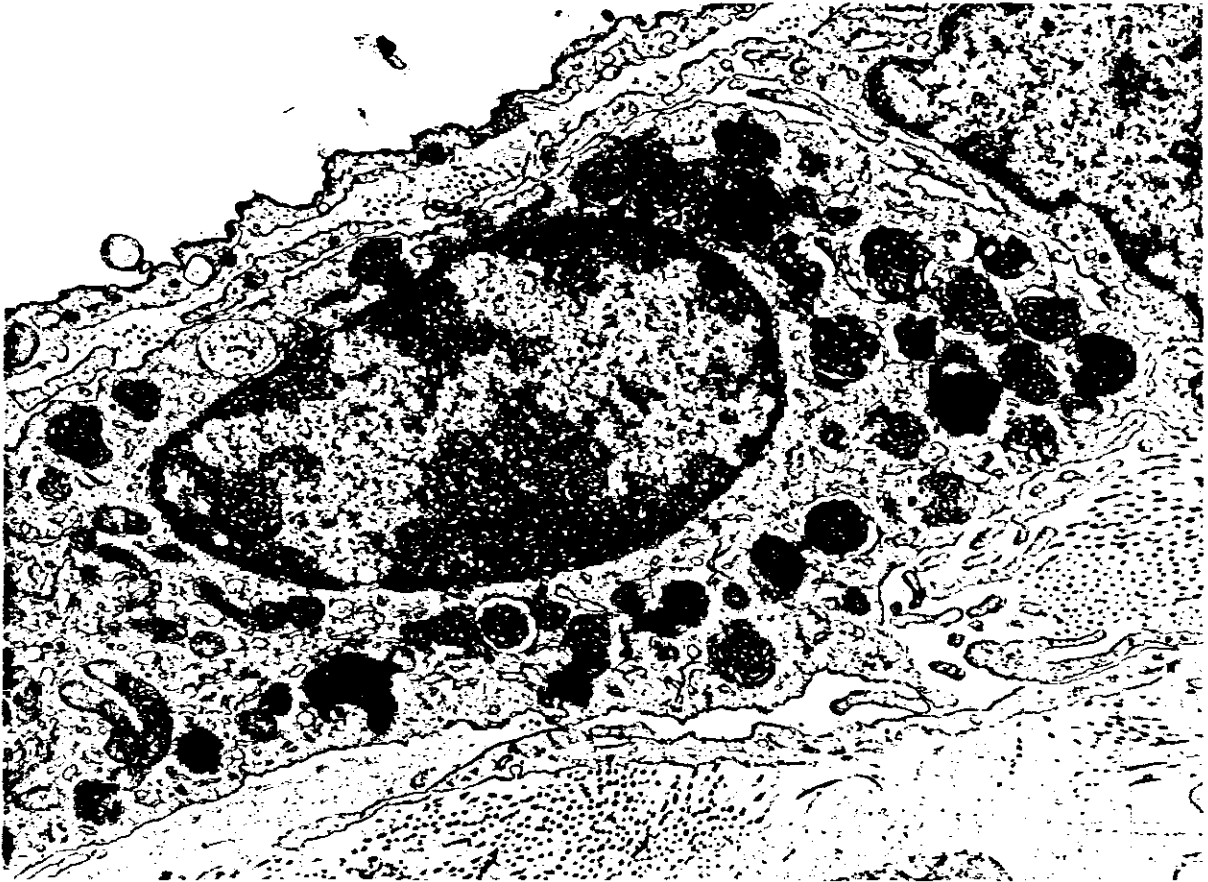

Figure 7. Human mast cell lying within the interstitium of a fibrotic lung area from a silicotic patient. Transbronchial biopsy. Electron micrograph. Magn. x17000.



Figure 8. Part of a parenchymal mast cell undergoing degranulation. The cell is closely connected to a fibrocyte. Transbronchial lung biopsy. Electron micrograph. Magn. x28000.

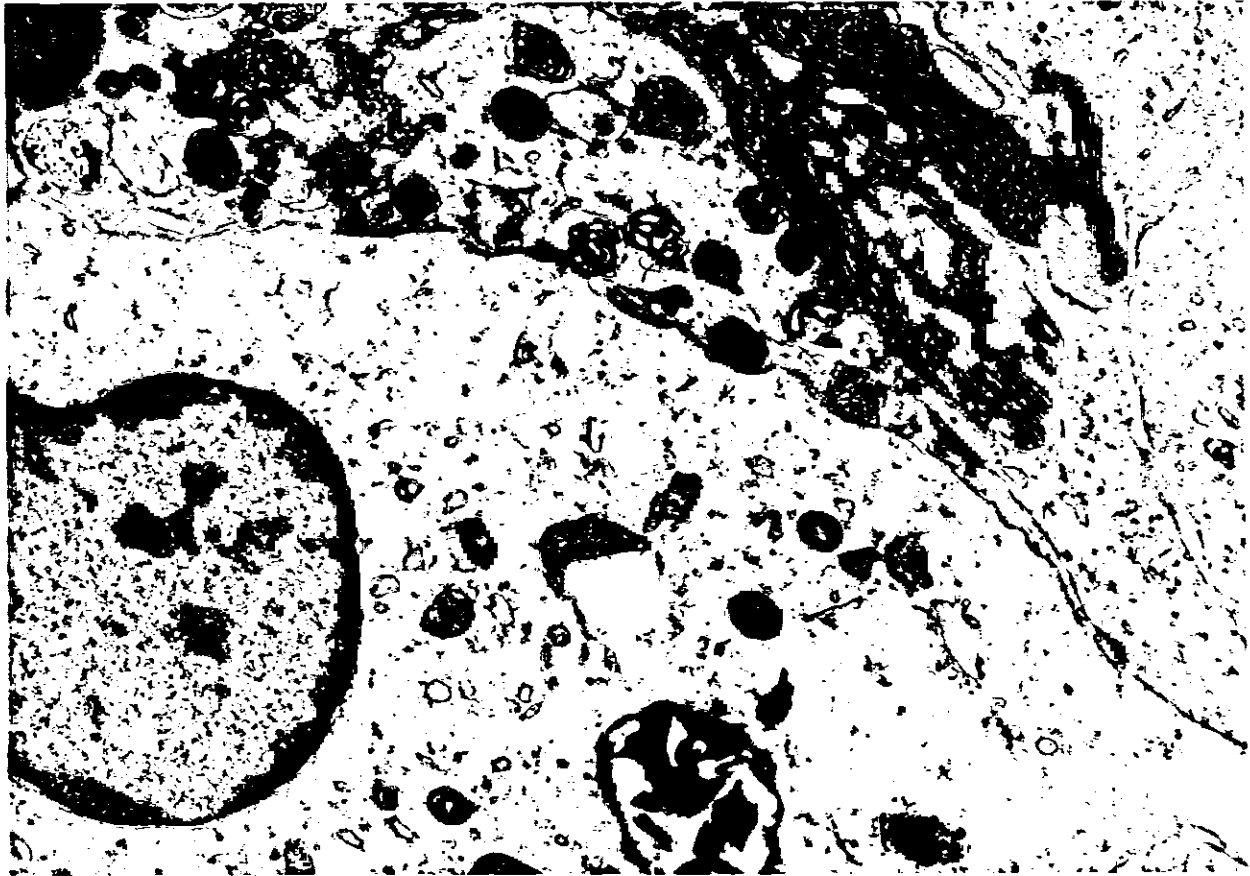

Figure 9. Interaction between a mast cell and a dust-containing macrophages in lung parenchyma of a silicotic patient. Transsbronchial biopsy. Electron micrograph. Magn. x17000.

5. Behrendt, H., Stiller-Winkler, R., Stutz, P., Magnussen, H.: Morphological evidence for two mast cell populations in bronchoalveolar lavage obtained from asthmatic and nonasthmatic patients. *Allergy* 43:72(1988).
6. Bienenstock, J., Befus, A.D., Denburg, J.A.: *Mast cell heterogeneity: Basic questions and clinical implications. Mast cell differentiation and heterogeneity*, pp. 391-402. A. D. Befus et al., Eds Raven Press, New York (1986).
7. Bowden, D.H., Adamson, Y.R.: The role of cell injury and the continuing inflammatory response in the generation of silicotic pulmonary fibrosis. *J. Pathol.* 144:149-161(1984).
8. Brain, J.D., Frank, N.R.: Recovery of free cells from rat lungs by repeated washings. *J. Appl. Physiol.* 25:63-69(1968).
9. Davidson, S., Kinarty, A., Coleman, R., Reshef, A., Ginsburg, H.: Fibroblasts are required for mast cell granule synthesis. *Mast cell differentiation and heterogeneity*, pp. 115-124. A.D. Befus et al., Eds. Raven Press, New York (1986).
10. Diaz, P., Jones, D.G., Kay, A.B.: Histamine coated particles generate superoxide (O_2^-) and chemiluminescence in alveolar macrophages. *Nature (Lond.)* 279:454-456(1979).
11. Faiman, M.D., Januskiewicz, A.J.: Pulmonary oxygen in the rat and the role of histamine. *Biochem. Pharmacol.* 35:3889-3892(1986).
12. Flint, K.C.: *Bronchoalveolar mast cells and asthma*, Springer, London (1987).
13. Goto, T., Befus, A.D., Low, R., Bienenstock, J.: Mast cell heterogeneity and hyperplasia in bleomycin-induced pulmonary fibrosis of rats. *Am. Rev. Respir. Dis.* 130:797-802(1984).
14. Metcalfe, D.D., Kaliner, M., Donlon, M.: The mast cell. *CRC Crit. Rev. Immunol.* 3:23-74(1981).
15. Norrby, K., Enerbäck, L., Franzen, L.: Mast cell activation and tissue cell proliferation. *Cell Tiss. Res.* 170:289-303(1976).
16. Schulman, E.S., Liu, M.C., Proud, D., MacGlashan, D.W., Lichtenstein, L.M., Plaut, M.: Human lung macrophages induce histamine release from basophils and mast cells. *Am. Rev. Respir. Dis.* 131:230-235(1985).
17. Tomioka, M., Ida, S., Shindoh, Y., Ishihara, T., Takishima, T.: Mast cells in bronchoalveolar lumen of patients with bronchial asthma. *Am. Rev. Respir. Dis.* 129:1000-1005(1984).
18. Uvnäs, B., Thon, L.L.: Isolation of 'biologically intact' mast cells. *Exptl. Cell Res.* 18:512-520(1959).
19. Williams, A., Heath, D., Kay, J.M., Smith, P.: Lung mast cells in rats exposed to acute hypoxia, and chronic hypoxia with recovery. *Thorax* 32:287(1977).
20. Ziesche, R., Wenners, J., Behrendt, H.: Morphological investigations on the initial effects of quartz DQ 12 on membranes in vitro. *North-Rhine Westfalia Silicosis Report Vol. 15:* 331-344(1985).

AUTOIMMUNITY PHENOMENA AND ALTERATIONS OF HUMORAL IMMUNOLOGICAL RESPONSES IN SILICOTIC PATIENTS

H. IDEL • N. H. Seemayer* • F. Prügger†

*Institute of Hygiene and Medical Institute of Environmental Hygiene, University of Düsseldorf, FRG

†Hospital of Occupational Diseases, AUVA, Tobelbad, Austria

INTRODUCTION

In the course of silicosis a variety of humoral alterations may occur.^{1,2,3,6,10-14} So far it is not known, if these humoral alterations are the cause or the consequence of the disease. The most important humoral alterations occurring in silicosis can be divided into three groups: 1) Parameters indicating a stimulation of macrophages: lysozyme, angiotensin-converting enzyme (ACE), fibronectin; 2) Effects on humoral immunity: immunoglobulins, complement, response to antigens; 3) Autoimmunity phenomena: antinuclear antibodies (ANA), circulating immune complexes (CIC), rheumatoid factors.

In our investigations on silicotic patients the following aspects were of particular interest:

1. Are serological changes, from which an influence of quartz-containing dust on the immune system and specific macrophage functions can be concluded, detectable in miners and other silicotic patients?
2. Are such changes detectable only when radiologically manifest silicosis exists or are they already detectable in exposed persons without silicosis?
3. Is there an influence of the quality of quartz containing dust on immunological disturbances?

MATERIALS AND METHODS

In this context, we studied four groups: 34 miners who had radiologically manifest fibrosis following exposure for 15 years and 40 miners who showed no radiological signs of silicosis even after exposure for more than 30 years. In addition 48 stone masons and quarriers were under investigation. For comparison a group of 25 non-exposed men was included.^{7,8}

The following parameters were studied in serum or plasma: lysozyme, angiotensin-converting enzyme (ACE), fibronectin, the complement component C_{3c}, immunoglobulins of classes IgG, IgA, IgE and IgM, circulating immune complexes (C₃, Clq, IgG, IgA, IgM bound in the complexes were detected here), and antinuclear antibodies (ANA). The methods used have been described previously in detail.^{5,8}

RESULTS AND DISCUSSION

Lysozyme, ACE and fibronectin which indicate macrophage stimulation (for review s.8) revealed significantly higher values in coal mine workers with and without pneumoconiosis in comparison to the control group. (Table I)

It has to be emphasized that the significantly increased values

Table I
Parameters Indicating Macrophage Stimulation in Silicotic Patients

	<u>COAL MINE WORKERS</u>		<u>CONTROL</u>
	<u>with silicosis</u>	<u>without silicosis</u>	
Lysozyme (mg/l)	8.25(±3.19) ^a (n=34)	6.75(±1.56) ^a (n=39)	5.00(±1.73) (n=25)
ACE (U/l)	391.71(±99.98) ^a (n=34)	367.69(±84.77) ^b (n=39)	297.84(±77.17) (n=25)
Fibronectin (mg/l)	65.47(±14.06) ^a (n=14)	58.84(±6.57) ^a (n=5)	38.42(±6.54) (n=25)

in paranthesis standard deviation, n=number of cases

Significantly increased over control a (p < 0.001; students t-test)
b (p < 0.01)

of these parameters were already detected in coal mine workers without radiological signs of fibrosis.

The determination of immunoglobulins of classes IgE and IgM showed no differences between the four groups. Also the concentration of the immunoglobulins of classes IgG and IgA was unchanged in miners with or without pneumoconiosis in comparison to control. In contrast, concentrations of IgG and IgA in sera of silicotic stone masons and quarriers were significantly increased over the values of the control group. Such variable findings concerning the IgG and IgA levels in sera of silicotic patients have also been reported by other authors. Beside data which are not striking¹¹ increases in the immunoglobulin classes IgG and IgA were reported.¹⁴ An important component of non-specific humoral immune response is the complement, which gets activated in cascade fashion by the classical or alternative pathway. In this process the complement component C₃ plays a central role, since it is involved in both pathways. Furthermore, of all complement components in serum, C₃ shows the highest concentration. Results of evaluation of the complement component C₃ in sera of the four groups were the following: coal miners with silicosis and silicotic stone masons and quarriers revealed the highest values. The differences to the control group were highly significant ($p \leq 0.001$).

It is especially remarkable that also coal miners without clinical signs of pneumoconiosis possessed high values of C₃, significantly different from controls ($p \leq 0.001$).

Of importance is the occurrence of circulating immune complexes (CIC) in sera of the four groups. For detection of immunoglobulins bound in these immune complexes we used the method of polyethylene glycol-precipitation and the radial immunodiffusion for subsequent determination of IgG, IgA and IgM.

Silicotic patients revealed significantly higher values of CIC than the non-exposed control group. It is remarkable that a significant increase of circulating immune complexes was already detected in coal miners without clinical signs of silicosis. Formation of immune complexes activates complement by the classical pathway. On the contrary, activation by the alternative pathway is not dependent on the presence of an antigen-antibody-reaction. Specifically, the latter one is activated by certain substances, such as bacterial endotoxins, macrophage enzyme elastase, and also by quartz dust.

It has to be emphasized that we found remarkable high concentrations of C₃ in sera of silicotic patients despite the fact that high concentrations of circulating immune complexes were present, which are known to bind and consume C₃. Results suggest that quartz dust induces activation of complement by the alternative pathway leading to increased values of C₃ in sera.^{8,14}

An important sign of autoimmunity phenomena is the occurrence of antinuclear antibodies (ANA) beside the presence of circulating immune complexes (CIC). For detection of ANA we used the method of indirect immunofluorescence. The kidney cell line CV-1 from *Cercopithecus aethiops* has been employed as the substrate. In this study 114 sera of non-exposed persons served as a control. In sera of non-exposed

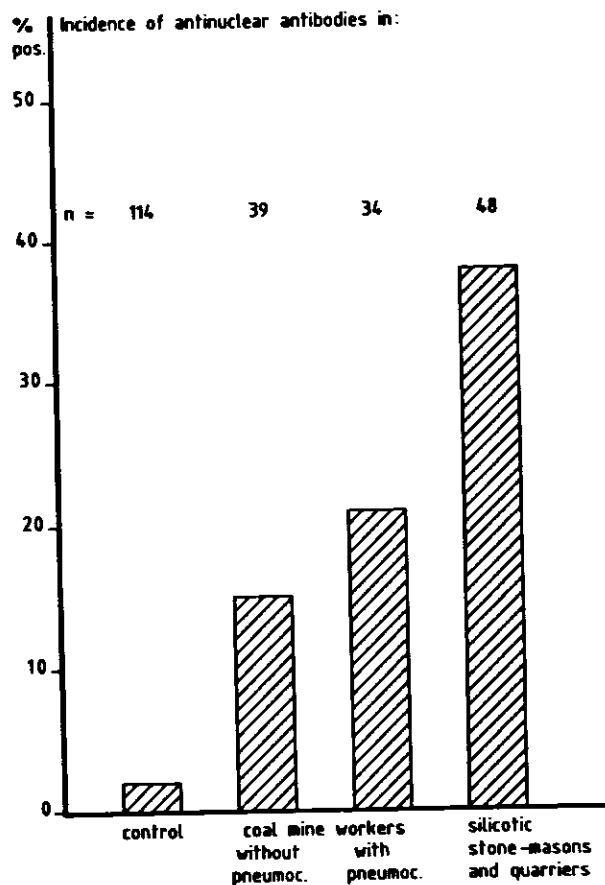

Figure 1. Incidence of antinuclear antibodies.

persons ANA were found in 2% of cases. In contrast, persons exposed to quartz-containing dusts are showing a remarkably higher incidence of ANA. So we found in sera of coal mine workers without pneumoconiosis ANA in 15% of cases, while in sera of coal mine workers with pneumoconiosis ANA were found in 21%. A nearly doubled incidence of ANA of 38% was found in sera of stone masons and quarriers (Figure 1). It is known that pattern of immunofluorescence of cell nuclei can be membranous, homogeneous, speckled and nucleolar depending on the reaction with the corresponding antigen. The pattern is schematically shown on Figure 2. Although all patterns of nuclear immunofluorescence were observed in silicotic patients, preferentially the type of homogeneous and speckled immunofluorescence was seen. As an example, in Figure 3 pattern of homogeneous immunofluorescence observed with ANA-containing serum from a silicotic patient is shown. As demonstrated by detection of ANA, the quality of quartz-containing dust has a great influence on the occurrence of immunological disturbances. The determination of all above described parameters is demonstrating almost the same effect: the alterations do not only occur when radiologically manifest silicosis exists, but are sometimes already found in miners without radiological fibrosis. These findings illustrate that quartz-containing dusts stimulate not only those functions of the macrophages which induce fibrosis,¹⁶ but

Pattern of Immunofluorescence of Cell Nuclei and corresponding Antigen in Presence of Anti-Nuclear Antibodies

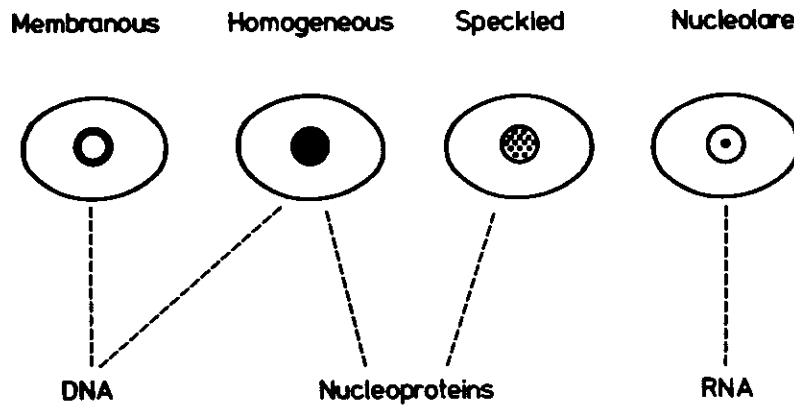

Figure 2. Pattern of immunofluorescence of cell nuclei and corresponding antigen in presence of anti-nuclear antibodies.

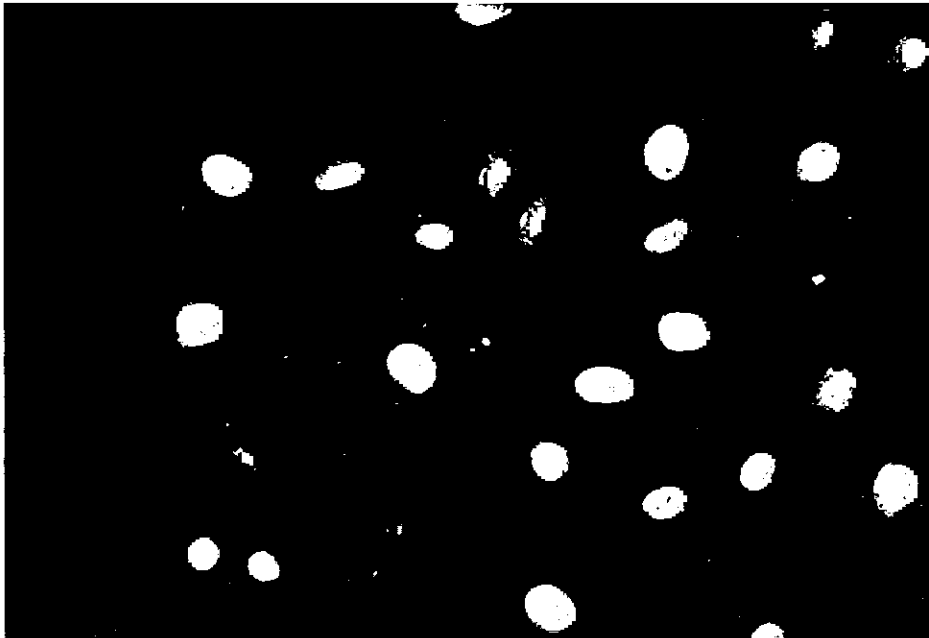

Figure 3. Pattern of homogeneous immunofluorescence of ANA.

at the same time the immunoregulatory functions and that disturbances in the latter functions are detectable before fibrosis or independently thereof.

Important recent findings demonstrate a cross-reactivity of anti-DNA antibodies with proteoglycans, cardiolipin and other phospholipids as well as with the intermediate filament vimentin.^{3,9,15} These reports allow a new view on autoimmunity in silicotic patients.

SUMMARY AND CONCLUSIONS

1. In silicotic patients the following humoral disturbances and autoimmunity phenomena are found:

- a. Indicators for macrophage stimulation, such as lysozyme, angiotensin-converting-enzyme (ACE), and fibronectin are increased.
- b. Effects on humoral immunity are seen by an increase of complement component C₃ and in part by an increase of immunoglobulins IgG and IgA.

Autoimmunity phenomena are shown by occurrence of antinuclear antibodies and of circulating immune complexes, containing C₃, IgG, IgA and IgM.

2. The above mentioned alterations do not only occur when manifest silicosis exists, but are also found in miners without radiologically fibrosis. These findings illustrate that quartz-containing dusts stimulate not only those functions of the macrophages which are involved in fibrosis, but also lead to immunoregulatory dysfunctions which are detectable before incidence or independently of a clinical manifest fibrosis.

3. As demonstrated by incidence of ANA, the quality of quartz-containing dust has a great influence on the manifestation of autoimmunity phenomena.

REFERENCES

1. Doll, N. J., et al.: Immune complexes and Autoantibodies in Silicosis. *J. Allergy Clin. Immunol.* 68:281-285 (1981).
2. Doll, N. J., Stankus, R. P., Barkman, W.: Immunopathogenesis of Asbestosis, Silicosis and Coal Workers' Pneumoconiosis. *Clin. Chest Med.* 4,1:3-14 (1983).
3. Faaber, P., J. A. Capel, G. P. M. Rijke, G. Vierwinden, L. B. A. van de Putte, R. A. P. Loew: Cross-reactivity of Anti-DNA Antibodies with Proteoglycans. *Clin. Exp. Immunol.* 55:502-508 (1984).
4. Hahon, N., Morgan, W. K. C., Petersen, M.: Serum Immunoglobulin Levels in Coal Workers' Pneumoconiosis. *Ann. Occup. Hyg.* 23:165-174 (1980).
5. Idel, H., Bunke, R., Seemayer, N. H.: Antinuclear Antibodies (ANA) in Patients with Malignant Diseases: Frequency of Occurrence and Immunological Characterization. *Zbl. Bakt. Hyg. I. Abt. Orig.B* 167:158-261, (1978).
6. Idel, H., Koldovsky, P.: *Immunomodulation Induced by Quartz Dust in Animals and Effect of Antisilicotic Treatment.* In: *Inhaled Particles VI* (in press).
7. Idel, H., Prügger, F., Schlipkötter, H.-W.: *Humoral Alterations in Silicotic Patients: Dependence on Stage of Silicosis?* (in preparation).
8. Idel, H., Goldbrunner, E., Alabanda, V., Brosch, N., Derwall, Kalkowsky, B., Schenk, V., Schöbel, L., Starovic, R., Bruch, J., Grosse-Wilde, H.: Alterations of Humoral Immunity in Coal Workers with and without Pneumoconiosis. *Silicosis Report North-Rhine Westfalia*, vol. 16:343-350 (1988).
9. Mackay, I. R., I. H. Frazer, L. J. McNeilage, S. Whittingham: Auto-Epitopes and Autoimmune Diseases. In: *Autoimmunity: Experimental and Clinical Aspects*, Ann. of the N.Y. Acad. of Sciences, vol. 475:59-65. R. S. Schwartz / N. R. Rose, New York (1986).
10. Miller, K.: Complement Factors in Workers Exposed to Silicosis. *Brit. J. Ind. Med.* 40:111-112 (1983).
11. Rasche, B.: *Untersuchungen möglicher Individualfaktoren bei der Entwicklung der Pneumokoniose im Steinkohlenbergbau. III. Immunologische Befunde.* In: *Ergebnisse von Untersuchungen auf den Gebiet der Staub- und Silikosebekämpfung im Steinkohlenbergbau*, vol. 13:355-360. Verlag Gfückauf, Essen (1981).
12. Seemayer, N. H., N. Manojlovic: Autoimmunity Phenomena in Coal Mine Workers and Pneumoconiotic Patients: Demonstration of Antinuclear Antibodies in Sera. *Silikosebericht Nordrhein-Westfalen, Bd. 14:357-367* (1983).
13. Shazo de, R. D.: Current Concepts about the Pathogenesis of Silicosis and Asbestosis. *J. Allergy Clin. Immunol.* 70:41-49 (1982).
14. Stiller-Winkler, R., Idel, H., Hallauer, J. F.: *Concentration of C₃ Component in Sera of Miners Exposed to Quartz Containing Coal Mine Dust and of Animals Exposed to Pure Quartz Dust.* In: *Vith International Pneumoconiosis Conference 1983.* International Labour Office (ILO) Genf, vol. 1:628-635 (1984).
15. Stollar, B. D., R. S. Schwartz: *Monoclonal Anti-DNA Antibodies: The Targets and Origins of SLE Autoantibodies.* In: *Autoimmunity: Experimental and Clinical Aspects*, Ann. of the N. Y. Acad. of Sciences, vol. 475:192-199. R. S. Schwartz/N. R. Rose, New York (1986).
16. Wahl, S. M.: The Role of the Lymphokines and Monokines in Fibrosis. *Ann. N. Y. Acad. Sci.*, vol. 460:224-231 (1985).

EFFECT OF QUARTZ DUST DQ 12 ON HUMAN MONOCYTES/MACROPHAGES *IN VITRO*—AN ELECTRON MICROSCOPICAL STUDY

HEIDRUN BEHRENDT • N.H. Seemayer

Medical Institute of Environmental Hygiene at the University
Auf'm Hennekamp 50, D-4000 Düsseldorf, FRG

INTRODUCTION

Quartz particles are highly cytotoxic to rodent macrophages *in vitro*.^{4,9,10} This cytotoxic effect is thought to be mediated by the lysis of phagolysosomal membranes through ingested quartz particles.² In comparison to cultured rodent macrophages human monocytes/macrophages are more resistant to quartz-induced cytotoxicity *in vitro*.⁶ Exposure of human macrophages to quartz mainly leads to the formation of fibroblast-proliferating factors and to the release of mediators which activate neutrophils to generation of oxygen species.^{3,8} This stimulatory action of quartz dust DQ 12 on human macrophages *in vitro* is morphologically paralleled by the development of a labyrinth of dilated vacuolar spaces within the cells.¹ Sequential analysis of quartz-exposed human macrophages by means of transmission electron microscopy further indicates the manifestation of specific autophagolysosomal processes which result in a vacuolar network filled with degradation products intrinsic to the cell in addition to quartz particles. From this study,¹ it has been concluded that human macrophages *in vitro* develop a protection mechanism against toxic quartz particles which is initiated by phagocytosis and which results in consecutive cell stimulation.

In the present study we report about surface alterations in human monocytes/macrophages *in vitro* which are induced by quartz DQ 12 and which further explain the considerably higher resistance of human macrophages to quartz particles *in vitro*.

MATERIALS AND METHODS

Cell Cultures

Isolation of human monocytes from peripheral blood in Ficoll-Hypaque gradient and cultivation of monocytes to maturation of cells with characteristics of macrophages has already been described in detail.^{6,7}

For transmission electron microscopical studies 25×10^6 mononuclear cells were seeded in tissue culture flasks (Falcon 3013), for scanning electron microscopy 2.5×10^6 cells were distributed on tissue culture plate with 24 wells (Falcon 3047, Multiwell tissue culture plate) containing round glass coverslips with a diameter of 12 mm. After removing of non-adherent cells monocytes were cultivated for 7–14 days to differentiate into mature macrophages as already

reported.^{6,7} The cells were then incubated with 100 μg quartz DQ 12 (particle size $< 5 \mu\text{m}$) per ml medium for 2, 24 and 48 hours. Cell viability has been tested by dye exclusion test.

Transmission Electron Microscopy

For transmission electron microscopy the cells were briefly fixed *in situ* by the addition of 2% buffered glutaraldehyde. After gently shaking to remove the cells from their substrate the cells were spinned down, pelleted and postfixed with osmium tetroxide. They were then dehydrated in a graded series of ethanol, and embedded in Araldite. Ultrathin sections were investigated in a Philips 400T electron microscope.

Scanning Electron Microscopy

For scanning electron microscopical investigations the cells were fixed *in situ* with buffered glutaraldehyde, post-fixed with osmium tetroxide and dehydrated in a graded series of ethanol. After short immersion in hexamethyldisilazane the cells were air dried according to the method of Nation,⁵ coated with gold, mounted and analyzed in a Philips SEM 515 electron microscope.

RESULTS

At concentrations which are highly cytotoxic to guinea pig macrophages, human monocytes/macrophages react with a considerable higher survival rate (Figure 1). Macrophages which had been exposed to 100 $\mu\text{g}/\text{ml}$ quartz DQ 12 for 48 hours display a vacuolar network filled with flocculent material and quartz particles (Figure 2) but no signs of cytotoxicity. No disruptions of lysosomal membranes were ever detected. The morphological picture rather results from processes of cell activation induced by quartz particles *in vitro*. The dilated vacuolar network is open to the extracellular space (Figure 2, Figure 3), so that the intravacuolar degradation products as well as the quartz particles are exposed to the extracellular micro-environment.

Connections between quartz-induced labyrinth formation and extracellular space—supposed to occur for the analysis of transmission electron micrographs¹—are also evident in cell samples which have been exposed to 100 $\mu\text{g}/\text{ml}$ quartz DQ 12 for 24 hours and subsequently investigated by scanning electron microscopy. As is indicated in Figure 6, deep in-

dentations or 'holes' can be seen on the surfaces of nearly all macrophages. One single foramen is usually characteristic for these cells. Since the formation of foramina can never be observed in cultured control macrophages (Figure 4) nor in cells being exposed to shorter times (2 hours, Figure 5) of the same quartz dust concentration, 'holes' are characteristically late phase alterations in otherwise vital cells. A comparison between Figure 3 and Figure 6 clearly indicates the similarity between sections through parts of dilated vacuoles containing fingerprint-like structures¹ and the formation of a foramen on their surface.

DISCUSSION AND CONCLUSIONS

Results obtained by scanning electron microscopy (presented

in this paper) and by transmission electron microscopy¹ indicate that cultured human monocytes/macrophages display unique features upon contact with toxic quartz particles. The higher resistance of the cells to quartz concentrations which are toxic for animal cells is underlined by a special mechanism of phagocytosis in combination with autophagolysosomal processes¹ and cell secretion.^{3,8} Similar observations have never been reported to occur in silica-exposed rodent macrophages. Therefore, the effects demonstrated by us are species specific characteristics of human cultured monocytes/macrophages which have been exposed to quartz particles.

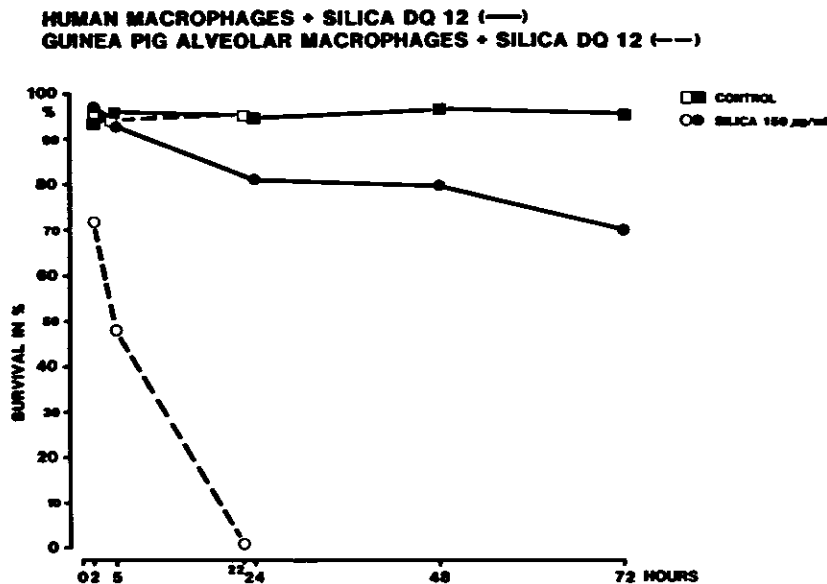

Figure 1. Effect of quartz DQ 12 on the survival rate of guinea pig alveolar macrophages and of human macrophages *in vitro*.

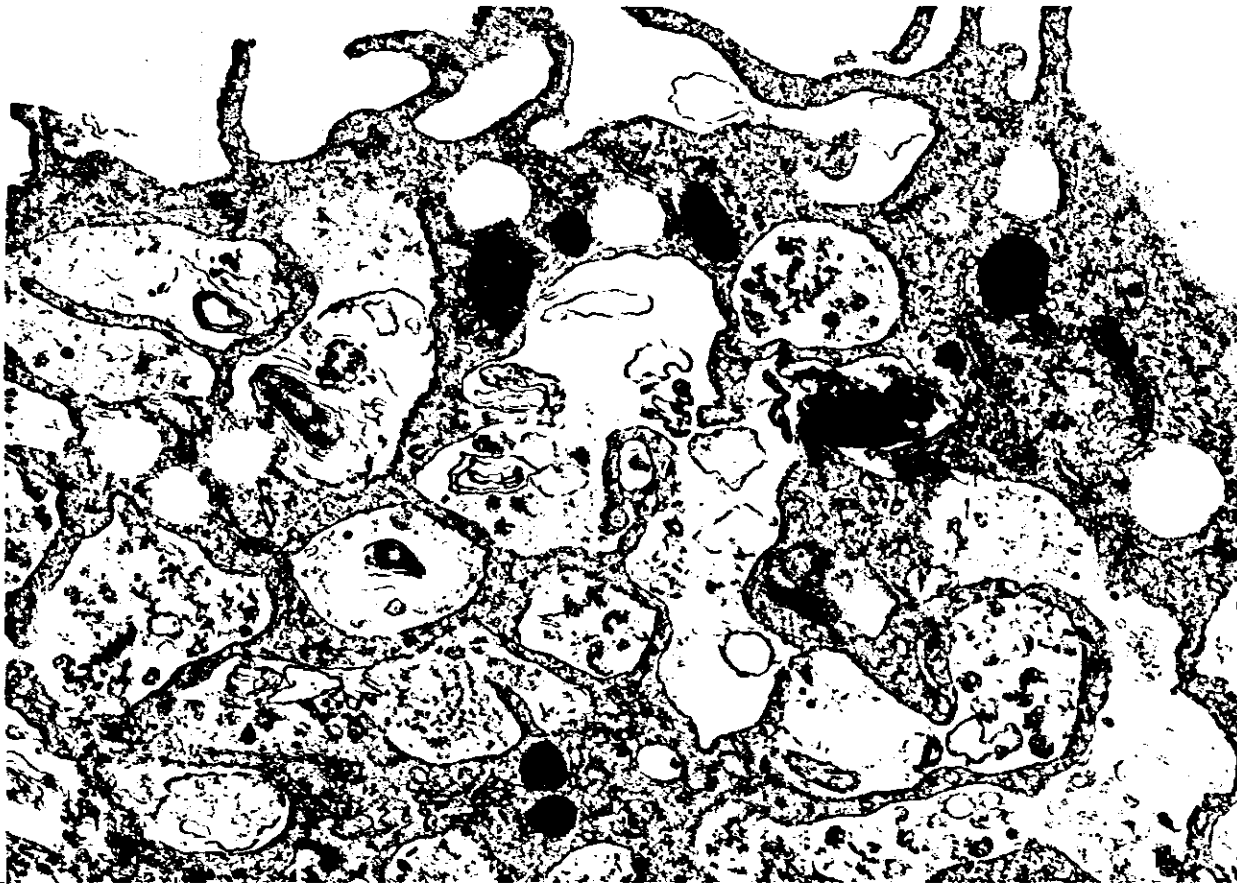

Figure 2. Part of a 12 days old human macrophage after incubation with 100 $\mu\text{g/ml}$ quartz DQ 12 in vitro. Development of a vacuolar network containing quartz particules and flocculent material. Transmission electron micrograph. Magn. $\times 25000$.

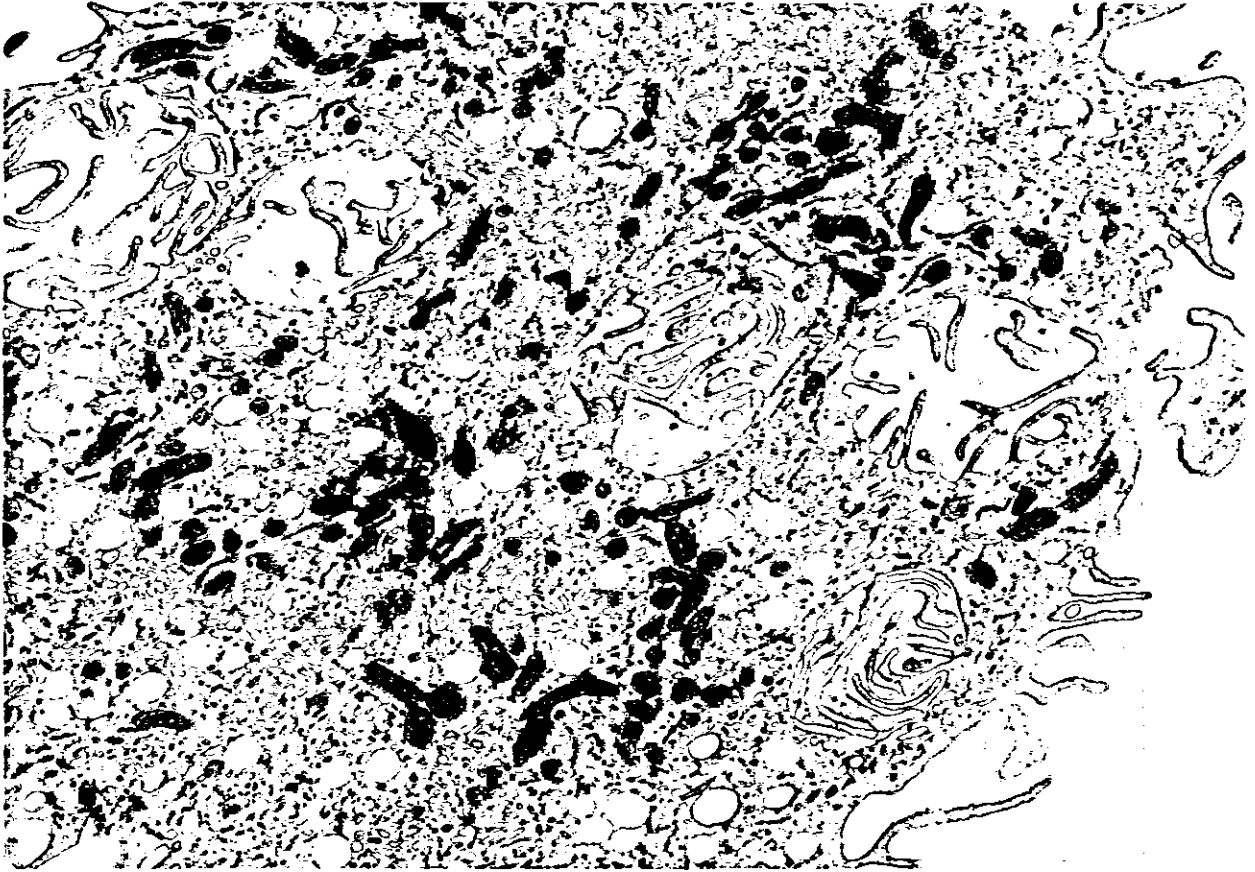

Figure 3. 12 days old human macrophage after incubation with 100 $\mu\text{g/ml}$ quartz DQ 12 in vitro. Section through a 'hole.' Transmission electron micrograph. Magn. $\times 9200$.



Figure 4. Human macrophages from a 12 days old culture. Scanning electron micrograph.

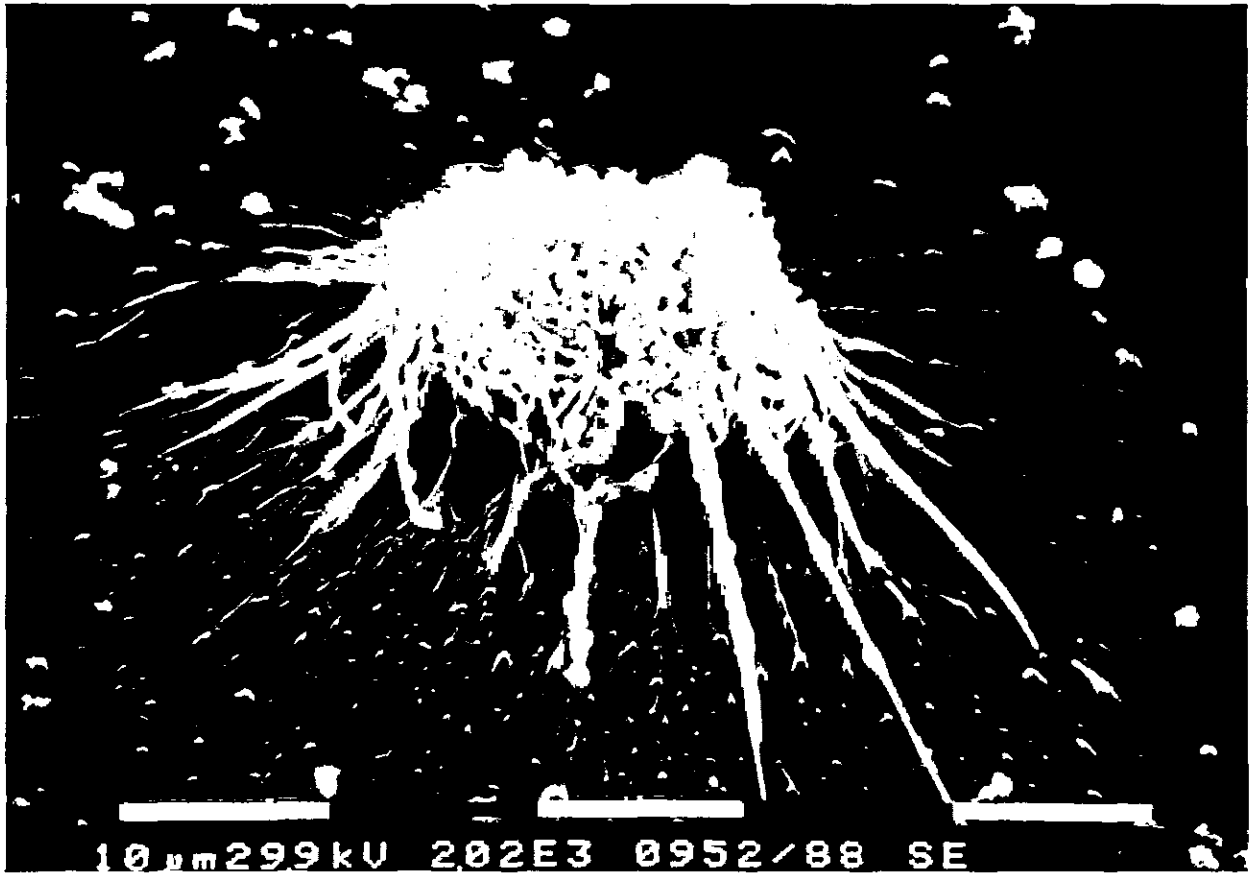

Figure 5. Scanning electron micrograph of a human macrophage after exposure to 100 µg/ml quartz DQ 12 for 2 hours in vitro.

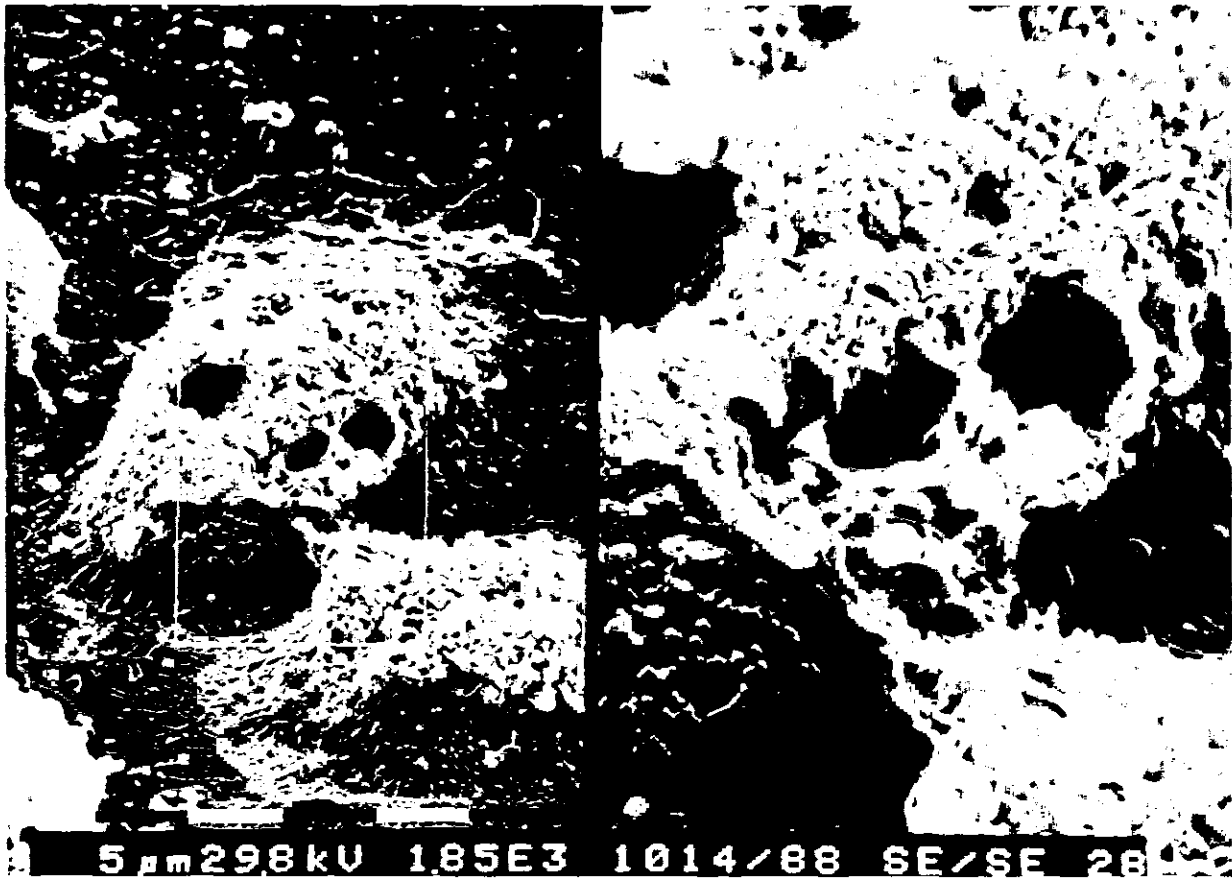

Figure 6. Scanning electron micrograph of a human macrophage after exposure to 100 µg/ml quartz DQ 12 for 24 hours, displaying characteristic 'holes.'

REFERENCES

- Behrendt, H., Seemayer, N.H., Braumann, A., Nissen, M.: Electron microscopy investigation of the effect of quartz dust DQ 12 on human monocytes/macrophages in vitro. *Silicosis Report North-Rhine Westfalia*. Vol. 16, 171-183 (1987).
- Comolli, R.: Cytotoxicity of silica and liberation of lysosomal enzymes. *J. Pathol. Bacteriol.* 93:241-253 (1967).
- Maly, E., Seemayer, N.H., Braumann, A., Behrendt, H., Manojlovic, N., Maly, F.E.: The significance of immunomodulative cytokines for the development of silicosis. I. Biological characterization of the granulocyte-activating mediator from human monocytes/macrophages treated with quartz dust DQ 12. *Silicosis Report North-Rhine Westfalia*. Vol. 16, 157-170 (1987).
- Morgan, D.M.L., Allison, A.C.: Effects of silica and asbestos on alveolar and peritoneal macrophages: a comparative study. In: *The in vitro effects of mineral dusts*, pp. 75-80. R.C. Brown, I.P. Gormley, M. Chamberlain, R. Davies, Eds. Academic Press, London (1980).
- Nation, J.L.: A new method using hexamethyldisilazane for preparation of soft insect tissues for scanning electron microscopy. *Stain Technol.* 58:347-351 (1983).
- Seemayer, N.H., Braumann, A.: Investigation on the cytotoxic effect of quartz dust DQ 12 and coal mine dusts on human macrophages. *Silicosis Report North-Rhine Westfalia*. Vol. 15, 301-320 (1985).
- Seemayer, N.H., Braumann, A.: Effects of particle size of coal mine dusts in experimental anthrocosilicosis: In vitro studies on human macrophages. *Ann. Occup. Hyg.*, in press.
- Seemayer, N.H., Braumann, A., Maly, E.: Development of an 'in vitro' test system with human macrophages and fibroblasts for analysis of the effect of quartz dusts and coal mine dusts. I. Formation of a fibroblast proliferation factor. *Silicosis Report North-Rhine Westfalia*. Vol. 16, 143-155 (1987).
- Seemayer, N.H., Manojlovic, N.: Biological effects of coal mine dusts on macrophages. The in vitro effects of mineral dusts, pp. 5-12. R.C. Brown, I.P. Gormley, M. Chamberlain, R. Davies, Eds. Academic Press, London (1980).
- Ziesche, R., Wengers, J., Behrendt, H.: Morphological investigations on the initial effects of quartz DQ 12 on membranes in vitro. *Silicosis Report North-Rhine Westfalia*, Vol. 15, 331-344 (1985).

MEDIATORS(S) FROM HUMAN MONOCYTES/MACROPHAGES INDUCED BY QUARTZ DUST DQ12 OR COAL MINE DUST TF-1 ARE LEADING TO RELEASE OF OXYGEN RADICALS FROM HUMAN GRANULOCYTES

E. MALY • N.H. Seemayer • Heidrun Behrendt • N. Manojlovic • F-E. Maly*

Medical Institute of Environmental Hygiene at the University, Gurlittstr. 53, D-4000 Düsseldorf, F.R.G.

*Institute of Clinical Immunology, Inselspital Bern, CH-3010 Switzerland

INTRODUCTION

Pneumoconiosis is a chronic inflammatory and fibrotic lung disease caused by long-term inhalation of quartz dust or quartz containing dust. Inhaled dust particles with a mass median aerodynamic diameter less than 5 μm may overcome the mechanisms of lung clearance and gain access to regional lymphatic tissue, hilar lymph nodes and subpleural aggregates. Here we find the typical fibrotic nodules, which consist of quartz dust laden alveolar macrophages, lymphocytes, polymorphonuclear granulocytes and fibroblasts. Alveolar macrophages seem to play a central role in the development of fibrotic tissue changes in the lung. Several authors reported that alveolar macrophages can influence the activity of inflammatory processes by production and secretion of soluble cytokines.^{4,5,6,8,11} Particular attention must be paid to the activation of polymorphonuclear granulocytes (PMN), since an increased immigration of PMN in the lung tissue, especially in the early phases of pneumoconiosis, has been reported by several investigators.^{3,7,8} Human PMN are potent inflammatory cells and their importance in the development of pneumoconiosis may be due to the effects of secretory products of activated PMN as f.e. collagenases, elastases, proteolytic enzymes, and especially reactive oxygen radicals (ROS).²⁰ Besides, activation of prolylhydroxylase, a key enzyme in collagen synthesis, by superoxide anion has been reported.² Therefore, we investigated whether cultivation of human monocytes/macrophages under exposure to quartz dust DQ12 or a typical coal mine dust from the Ruhr-area could lead to the liberation of mediators, which in turn could activate PMN. Since toxicity of PMN is largely dependent on their generation of free oxygen radicals, we examined the activation of the oxidative burst of PMN by supernatants of quartz or coal mine dust exposed cultures of human mononuclear cells. Furthermore, we studied the morphological changes of PMN under influence of quartz dust induced mononuclear cell supernatants with a transmission electron microscope.

MATERIALS AND METHODS

Cell Cultures

Isolation of human monocytes and PMN from the peripheral blood of healthy donors by Ficoll-Hypaque density centrifugation as well as the maturation of monocytes to cells

with characteristics of macrophages have been described in detail.¹⁷

Dust Samples

Quartz dust DQ12 was used as fibrogenic stimulus for cultures of human mononuclear cells. This is Dörentrupper crystall quartz flour (grinding No.12) with a particle size 5 μm . Furthermore a typical coal mine dust (TF-1, fraction BAT-II) from a colliery of the Ruhr-area was tested. It is characterized by a high mineral content (95 weight%), a quartz content of 10.6 weight% and a grain size distribution from 0.5 to 2.5 μm .¹⁸ Electrocorund (BAR 3 S, particle size < 5 μm) was used as non cytotoxic control.

Detection of Free Oxygen Radicals

Measurement of formation of reactive oxygen species, in particular of superoxide anion, from activated PMN was performed using lucigenin dependent chemiluminescence (CL).¹ For this purpose we either used a 6-channel luminometer (LB9505, Berthold, Wildbad, FRG) or a microtiterplate image luminometer (C-1966, Hamamatsu Photonics Europe, Herrsching, FRG) as reported earlier.^{12,14,15} Furthermore, we studied the activation of the oxidative burst of PMN applying the cytological nitroblue tetrazolium reduction capacity test (NBT test): the percentage of detectable "formazan-cells"—associated with the uptake of nitro-blue tetrazolium and its reduction to formazan—reflects the activation of PMN by oxidative processes.¹⁰

Biological and Biochemical Characterization of Mediators

In order to approach the nature of the mediator(s) in the supernatants of dust treated cultures of mononuclear cells we analyzed the dose effect relationship, the thermostability, and the effect of treatment of the mediators with various enzymes.^{13,14} Preliminary estimation of the molecular weight of the mediator(s) involved were performed using HPLC gel filtration techniques (TSK 2000) as reported previously.¹⁴ In order to evaluate the cellular origin of the mediator(s) responsible for the activation of PMN we isolated monocyte depleted and monocyte enriched cell suspension and incubated them with quartz dust DQ12 (50 $\mu\text{g}/\text{ml}$, 24h). Cellular composition of isolated cell suspensions was deter-

mined by cell surface marker analysis with an Ortho cytofluorograph (model 50 H) using FITC-labelled mouse monoclonal antibodies as described earlier.¹⁴

RESULTS

Supernatants of quartz dust DQ12 treated mononuclear cells are capable of stimulation of human PMN to a highly significant and long lasting chemiluminescence, which reflects the release of superoxide anion from activated PMN.¹ The mediator(s) in the supernatants responsible for this effect were called "Granulocyte Activating Mediator(s)." "GRAM". However, this activation of PMN was strictly dependent on the sort and dose of dust used for production of supernatants. Highest values of CL of PMN were obtained with supernatants from mononuclear cells exposed to 50–100 µg/ml quartz dust DQ12 for 24 hours. Even the tested coal mine dust TF-1 was able to release GRAM's from mononuclear cells,¹⁴ but in contrast to quartz dust DQ12 peak values of CL of PMN were obtained using 200 µg/ml TF-1 for production of supernatants. Interestingly, electrocorund, known for its non-fibrogenic behaviour, was unable to release GRAM's from mononuclear cells.¹⁴ Furthermore, we analysed the influence of the time of exposure of quartz dust DQ12 to mononuclear cells on the release of GRAM's. After an incubation period of only 4 hours low amounts of GRAM's were detected. Highest values were measured after an incubation period of 24 hours.¹⁴ After 48, 72, and 96 hours of incubation release of GRAM's was reduced to approximately 50% of the peak value obtained after 24 hours. Therefore, supernatants harvested from cultures of mononuclear cells exposed to 50 µg/ml quartz dust DQ12 for 24 hours were used as "standard-GRAM" for further characterisation of GRAM. Exposure of PMN to "standard-GRAM" in the NBT-test led to a threefold increase in the formation of formazan-cells.^{12,14} This result again underlines the activation of the oxidative burst of PMN by GRAM's. We also analyzed the morphological changes of PMN exposed to GRAM with a transmission electron microscope. We found, that in contrast to control cells PMN which were exposed to GRAM for 15 min. present marked signs of chemotactic activity as can be seen by changes of the cell shape and development of a leading lamella. After an incubation period of 45 min. PMN seem to enlarge to some extent. After 60 min. of incubation we found a reduction of chemotactic activity. Additionally, we detected a loss of intracytoplasmatic granules, indicating the release of lysosomal products.^{12,14} In further studies we investigated some biological and biochemical properties of GRAM. The chemiluminescence inducing activity of standard-GRAM was detectable up to a dilution 1:16.¹⁴ Activity of GRAM was progressively diminished by heat treatment and was abolished after boiling of supernatants.¹⁴ After treatment of GRAM with hydrolytic enzymes and subsequent testing of the remaining CL induction on PMN, it was demonstrated that GRAM is relatively stable towards ribonuclease, neuraminidase and trypsin, whilst chymotrypsin and protease significantly reduced the activity.^{13,14} Preliminary estimations of the molecular weight of GRAM using HPLC gelfiltration techniques indicated that the chemiluminescence

inducing activity of GRAM is probably caused by two substances with a m.w. of about 10 kDa and 20 kDa resp.¹⁴ In further studies we investigated the cellular origin of GRAM. Therefore, we incubated monocyte enriched and monocyte depleted cell suspensions with 50 µg/ml quartz dust DQ12 for 24 hours. Supernatants were harvested and tested on their ability to induce chemiluminescence of PMN. Results demonstrated that monocyte depleted cell cultures (95% lymphocytes, 5% monocytes/macrophages) were unable to release sufficient amounts of GRAM. Cultures of mononuclear cells consisting of 17% or 50% of monocytes/macrophages were strong inducers of release of GRAM.¹⁴ Data suggest that monocytes/macrophages and not lymphocytes are the main producers of GRAM.

DISCUSSION AND CONCLUSION

Results presented demonstrate that human monocytes/macrophages in culture release a soluble mediator(s) following incubation with quartz dust DQ12 or coal mine dust TF-1. The mediator(s) stimulates human PMN to the release of reactive oxygen species, especially of superoxide anion. Therefore, we named this mediator(s) "Granulocyte Activating Mediator(s)," "GRAM". Some important characteristics of GRAM are summarized in Table I: Human monocytes/macrophages are able to release GRAM's if stimulated with low amounts of fibrogenic dust particles (quartz dust DQ12 or coal mine dust TF-1 were tested). The relative thermoresistance of GRAM and the sensitivity of GRAM against treatment with protease or chymotrypsin suggest a protein nature of GRAM. Preliminary determination of the molecular weight of GRAM indicates that two molecules (or two parts of one molecule) with a m.w. of approximately 10 kDa and 20 kDa resp. are responsible for the observed chemiluminescence. Besides the enhancement of the oxidative burst of PMN by GRAM we observed the induction of strong chemotactic changes as well as the release of lysosomal products from GRAM treated PMN in a time dependent manner by ultrastructural analysis. Taken together our results present an *in vitro* example of possible non-direct mechanisms of quartz- and coal mine dust pathogenicity. Monocytes/macrophages, when treated with low amounts of quartz dust DQ12 or coal mine dust TF-1 release a soluble cytokine like mediator(s), which then in turn activates human PMN to production of reactive oxygen species. Oxygen species could either directly be toxic and thus lead to alveolar damage^{9,16} or could enhance activity of prolylhydroxylase, a key enzyme in collagen synthesis.² Furthermore, the chemotactic effects of GRAM on PMN may explain the immigration of PMN in the early phases of silicosis.

In previous studies we reported that human monocytes/macrophages under influence of quartz- or coal mine dust release a "Fibroblast Proliferation Factor," "FPF".^{17,19} The question whether FPF and GRAM are identical has not yet been investigated. Therefore, further research concerning biological and biochemical properties of the mediators described is needed. Our investigations as done so far point to new non-direct, cytokine mediated mechanisms of pneumoconiosis. Measurement of the release of such

Table I

Important Characteristics of Quartz and Coal Mine Dust Induced Granulocyte Activating Mediator(s)

GRANULOCYTE ACTIVATING MEDIATOR (GRAM)

Source:	Human monocytes/macrophages
Inducing Agent:	Quartz dust DQ12, Coal mine dust TF-1
Molecular Weight:	- one (part of a) molecule with m.w. about 20 kda - another (part of a) molecule with m.w. just <10 kda (preliminary estimation, reduced by data from HPLC gel-filtration)
Stability:	56°C, 60 min - 37% loss of activity 80°C, 60 min - 58% loss of activity 100°C, 60 min - 81% loss of activity
Sort of molecule:	Protein nature
Target cells:	human polymorphonuclear granulocytes (PMN)
Effects:	Induction of chemiluminescence of PMN Formation of Formazan cells morphological changes of PMN
Results:	- Metabolic activation with release of oxygen radicals (superoxide anion) from PMN - chemotactic activation of PMN

mediators may be helpful to estimate the noxious effects of respirable particles.

REFERENCES

- Allen, R.C.: Lucigenin chemiluminescence: A new approach to the study of polymorphonuclear leukocyte redox activity. *Bioluminescence and Chemiluminescence*. Ed. by M. A. DeLuca and W. D. McElroy. Academic Press New York, 63-73 (1981).
- Bathnagar, R.S.: The role of superoxide in oxidant-induced pulmonary fibrosis. *Biochemical effects of Environmental Pollutants*. Ed. by S. D. Lee. Ann Arbor Science Publ., Ann Arbor, Mich. 47-58 (1977).
- Behrendt, H., Friedrichs, K.H.: Effect of low dose and short-time inhalation of silica dust on the morphology of rat lungs. *Aerosols: Formation and Reactivity*. Pergamon Journals Ltd., GB, 279-282 (1986).
- Berardi, M., Begin, R., Rola-Pleszcynski, M.: Stimulation of neutrophil chemiluminescence by alveolar macrophages from patients exposed to asbestos. *In vitro effects of mineral dusts*. Ed. by E.G. Beck and J. Bignon., Springer Verlag Berlin-Heidelberg, FRG, 83-91 (1985).
- Bittermann, P.B., Rennard, S.I., Hunninghake, G.W., Rystal, R.G.: Human alveolar macrophage growth factor for fibroblasts: regulation and partial characterisation. *J. Clin. Invest.* 70:806-822 (1982).
- Bittermann, P.B., Adelberg, S., Crystal, R.G.: Mechanisms of pulmonary fibrosis: spontaneous release of the alveolar macrophage-derived growth factor in the interstitial lung disorders. *J. Clin. Invest.* 72:1801-1813 (1983).
- Dauber, J.H., Rossman, M.D., Daniele, R.P.: Pulmonary fibrosis: Bronchoalveolar cell types and impaired function of alveolar macrophages in experimental silicosis. *Environ Res.* 27:226-236 (1982).

8. Davis, G.S.: Pathogenesis of Silicosis: Current concepts and hypotheses. *Lung* 164 No. 3:139-154 (1986).
9. Fox, H.B., de Togni, P., Babior, B.M.: Phagocytes and carcinogenesis. *Immunology Today* Vol. 6 No. 11:327-328 (1985).
10. Gifford, R.H., Malawista, S.E.: The nitroblue tetrazolium reaktion in human granulocytes adherent to a surface. *Yale J. of Biology and Medicine* Vol. 45:119-132 (1972).
11. Lugano, E.M., Dauber, J.H., Daniele, R.P.: Silica stimulation of chemotactic factor release by guinea pig alveolar macrophages. *J. of the Reticuloendothelial Society* Vol. 30:381-390 (1981).
12. Maly, E., Seemayer, N.H., Braumann, A., Behrendt, H., Manojlovic, N., Maly, F.-E.: Die Bedeutung von immunmodulativen Zytokinen für die Silikoseentstehung. I. Biologische Charakterisierung eines Granulozyten-Aktivierenden Mediators aus Quarzstaub DQ12 behandelten menschlichen Monozyten/Makrophagen. *Ergebnisse von Untersuchungen auf dem Gebiet der Staub- und Silikosebekämpfung im Steinkohlenbergbau* Bd.16 201-211 (1986).
13. Maly, E., Braumann, A., Seemayer, N. H., Maly, F.-E.: Induction of chemiluminescence of human granulocytes by supernatants of human mononuclear cultures after treatment with quartz dust DQ12. *Bioluminescence and Chemiluminescence. New Perspectives*. Ed. by J. Schlmerich, R. Andreesen, A. Kapp, M. Ernst and W. G. Woods. J. Wiley & Sons, Chichester-New York 121-124 (1987).
14. Maly, E.: Generation of free oxygen radicals from human polymorphonuclear granulocytes by cytokines from human mononuclear cells, treated with quartz dust DQ12 or coal mine dust TF-1.- New aspects in pathogenesis of pneumoconiosis. *Zbl. Bakt. Hyg. B* (in press).
15. Maly, F.-E., Urwyler, A., Rolli, H. P., Dahinden, C.A. De Weck, A.L.: A single-photon-imaging system for simultaneous quantitation of luminescent emissions from multiple samples. *J. of Analytical Biochemistry* 168:462-469 (1988).
16. McGoowan, S.E., Murray, J.J.: Direct effects of neutrophil oxidants on elastase-induced extracellular matrix proteolysis. *Am. Rev. Respir. Dis.* Vol. 135:1286-1293 (1987).
17. Seemayer, N.H., Braumann, A.: Untersuchung über die zytotoxische Wirkung von Quarz- und Grubenstäuben auf menschliche Makrophagen in vitro. In: *Ergeb. Unters. Geb. Staub- und Silikosebekämpfung im Steinkohlenbergbau. Silicosis Report North-Rhine Westphalia*, Vol 15 ,Essen : Steinkohlenbergbauverein, p. 301-320 (1985).
18. Seemayer, N.H.: Importance of grain size and mineral content of coal mine dusts for cytotoxicity on macrophages in vitro. *In vitro effects of mineral dusts*. Ed. by E. G. Beck and J. Bignon, Springer-Verlag Berlin-Heidelberg 497-504 (1985).
19. Seemayer, N.H., Braumann, A., Maly, E.: Entwicklung eines "in vitro" Testsystems mit menschlichen Makrophagen und Fibroblasten zur Analyse der Wirkungen von Quarz- und Grubenstäuben. I. Bildung eines Fibroblasten-Proliferationsfactors. *Ergebnisse von Untersuchungen auf dem Gebiet der Staub- und Silikosebekämpfung im Steinkohlenbergbau* Bd. 16 191-199 (1987).
20. Weiss, S.J., Lobuglio, A.F.: Biology of disease: Phagocyte generated oxygen metabolites and cellular injury. *Laboratory Investigation* Vol. 47 No. 1:5-19 (1982).

CYTOTOXICITY AND SPECTROSCOPIC INVESTIGATIONS OF ORGANIC FREE RADICALS IN FRESH AND STALE COAL DUST

N.S. DALAL* • B. Jafari* • V. Vallyathan† • F.Y.H. Green†

*Chemistry Department, West Virginia University, Morgantown, WV 26506, USA

†Department of Pathology, West Virginia University, Morgantown, WV 26506, USA

INTRODUCTION

The mechanistic details of the biological events leading to coal workers pneumoconiosis (CWP) are not yet fully understood, despite several decades of extensive epidemiologic^{1,2} and laboratory studies.²⁻⁶ Epidemiologic studies^{1,2} have shown, for example, that the incidence and severity of CWP differ markedly in the different regions and mines at comparable exposures, but laboratory investigations²⁻⁶ have demonstrated only partial correlation of the epidemiologic data with the differences in the mineral composition and the rank of coal mined. In particular, while epidemiologic data indicate^{1,2} direct correlation of the prevalence and severity of CWP with the rank (i.e., % carbon content) of coal, this correlation has not been established by laboratory⁴⁻⁶ and animal exposure³ studies. In order to explain these results, in 1980 Artemov and Reznik⁷ suggested that perhaps they arise from the fundamental differences in the surface properties of the coal dusts inhaled by the coal miners and those used in the laboratory studies: while the miners inhale freshly fractured coal particles, henceforth called the 'fresh' coal dust, the laboratory studies generally utilize 'aged' coal dusts (i.e., dusts that have been stored for many days or even longer). Reznik and Artemov⁷ used electron spin resonance (ESR) spectroscopy to show that the mechanical crushing of some Soviet Union coals generated organic free radicals and that the concentration and the decay times (hence the reactivity) of these radicals were higher for the coals of higher ranks. Since some of the radicals decayed within a few minutes in air, the authors surmised that while these radical species could lead to certain specific pathogenic reactions at the sites of mining operations, this might not be the case in the laboratory studies, due to the conventional use of 'stored' dusts which would be expected to contain significantly smaller free radical concentrations. This is consistent with the recent findings that, standardized, aged coal dusts exhibit minimal cytotoxicity.⁸

While the above mentioned work of Artemov and Reznik⁷ did suggest a possible new clue to the pathogenesis of CWP (i.e., the role of the coal based free radical species), no direct biological/cytotoxicity data were provided to show that 'fresh' coal dusts were, indeed, more pathogenic than the 'stale' ones. Because of the rather significant implications of the Artemov-Reznik hypothesis to the understanding of

the biochemical mechanism and, hence, the strategies for the eventual containment of CWP, we have initiated a comparative study of the free radical formation and cytotoxicity properties of freshly crushed coal particles. As done by Artemov and Reznik,⁷ we have used the ESR technique as the direct method of measuring the concentration and decay kinetics of the coal based free radicals. Our preliminary ESR studies on two Pennsylvania coals, a bituminous (carbon content 72%) and an anthracite (95% carbon) coal, have confirmed the Artemov-Reznik finding that the crushing-induced free radical sites are higher on the coals with higher carbon content (i.e., higher rank).⁹⁻¹¹ In the present work we describe our more recent results of a parallel study of the time dependence of the decrease in the free radical content of a freshly made anthracite dust (as measured via ESR) and that of the dust's cytotoxicity potential as measured by the extent of hemolysis of (sheep) erythrocytes. We have also investigated the effects of free radical scavengers on the cytotoxicity potential of the dust and deduce that indeed the free radicals could play a significant role in the initial events in the mechanism of the cytotoxic effects due to the inhalation of coal dust inhalation.

MATERIALS AND METHODS

Reagents

The anthracite coal (#PSOC-867 Carbon content = 95%) was obtained from the Generic Respirable Dust Technology Center, Pennsylvania State University, University Park, Pennsylvania, USA. The samples were received as particles of about 5 mm (longest) dimension. These particles were hand crushed using an agate mortar-pestle arrangement to sizes smaller than 20 microns. A mixed particle size, rather than a specific size fraction, was used in our studies as an effort to simulate the rather random, respirable size coal dust particles in the mining operations. Superoxide Dismutase (SOD) and catalase were purchased from Sigma and were used as received.

ESR Measurements

ESR spectroscopy was used for identifying the crushing-induced coal radicals, and to follow their concentration. The ESR measurements were made with a Bruker ER-200D spectrometer operating at X-band (≈ 9.5 GHz) frequencies, with

100 kHz field modulation. The magnetic field is controlled via a linearized Hall probe (Bruker, model ER031M) and calibrated with a self-tracking NMR gaussmeter (Bruker, model ER035M). The microwave frequency was measured with a Hewlett-Packard 5340A digital frequency counter. All ESR measurements were carried out at room temperature.

Hemolysis Measurements

Hemolytic activity of the coal dust was measured, following an established method,¹² as the amount of hemoglobin released from a 4% suspension of sheep erythrocytes after incubation with 5 mg and 10 mg of coal dust for one hour at 37°C. The hemoglobin release was estimated via the absorbance at 540 nm using a Gioford spectrophotometer. The procedure was phosphate buffer solution as a negative control (background) and 0.5% Triton-X-100 as a positive control (100% hemolysis). The percentage of hemolysis was calculated as follows:

$$\% \text{ Hemolysis} = (I_{\text{coal}} - I_{\text{neg}}) / (I_{\text{pos}} - I_{\text{neg}})$$

where I_{coal} is the absorbance after incubation with the silica dust, while I_{neg} and I_{pos} are those with buffer only and 0.5% Triton-X-100, respectively.

RESULTS AND DISCUSSION

Radical Concentration vs. Crushing Under Nitrogen

Figure 1 shows three typical, first derivative, ESR spectra of the Pennsylvania anthracite coal (PSOC-867). Figure 1 (a) corresponds to the radicals from the stale, uncrushed particles while (b) and (c) are the spectra from 200 x 200 mesh (smaller than 40 micron) and the 400 x 400 mesh (smaller than 20 microns) particles. All of the signals are assigned to the highly delocalized carbon-centered organic free radicals, based on the measured g -value of 2.0029, Lorentzian lineshapes with peak-to-peak widths of about 1 Gauss.¹³ Since the lineshapes and widths of all three spectra are essentially the same, the peak-to-peak heights of the first derivative spectra are proportional to the radical concentration in the respective preparations. It is evident that the smaller the particle size the larger the free radical concentration. The measured radical concentrations for all three samples are present in Table I.

Radical Decay in Air

As noted earlier,^{9,13} the free radical signals decreased upon exposure of the samples to air, or oxygen. In order to investigate the effect of the crushing in air, as would be the case in the mining environment, some particles (the more shiny ones) were crushed in air to sizes of smaller than 25 microns and kept in air contact during ESR measurements every five minutes over 170 hours, without disturbing the sample or the spectrometer settings. Figure 2 shows three typical ESR spectra taken dependence of the free radical concentration. We note here that the radical concentration was measured from the areas under the ESR signal via double integration of the derivative peaks. It is seen from Figure 2 that the radical decay pattern seems to exhibit an oscillatory behavior up to about 24 hours after which the decay is monotonous. While much more detailed experimentation is necessary to establish the origin of this complex decay

kinetics, it was found reproducible in two independent sets of measurements. Table II lists some of the selected data points. While the mechanism for the complex decay kinetics is not clear, a somewhat similar fluctuational behavior was noted in the hemolysis measurements as discussed next.

Hemolysis By Fresh vs. Stale Coal Dust

In order to determine if the freshly-crushed coal particles, containing higher amounts of free radicals, are more cytotoxic than the same particles on storage, we carried out hemolysis measurements on dust particles from the same stock as used in the above discussed radical kinetics. The hemolysis measurements were made for two dust concentrations at specific times (0-1/2, 4, 24, and 96 hours) after crushing. The average hemolytic activity was determined as 24.5% for the 5 mg/ml and 45.3% for the 10 mg/ml coal dust samples for the 0-1/2 hour period. The other measured values are included in Table III and represented graphically in Figure 3. Both Table III and Figure 3 reveal that the hemolytic activity decreased significantly as a function of the dusts' storage in both air and in a phosphate buffered saline (PBS) solution. It is also seen that the air stored dust samples exhibited a faster decrease in the hemolytic activity as compared to the PBS-stored samples.

Effect of Radical Scavengers

The above ESR measurements on 'fresh' coal dust demonstrated that the free radical sites on the coal particles react with oxygen in the air, and that this reaction increases the cytotoxicity of the dust particles. In order to find further clues to the biochemical mechanism of the oxygen-radical involvement in the cytotoxicity, hemolysis measurements were made in the presence of several oxygen-radical scavengers as discussed below.

Superoxide Dismutase (SOD)

The superoxide dismutase (SOD) was the first radical quencher enzyme tested for its effect on the hemolysis because SOD is known to provide an enzymatic defense mechanism against oxygen toxicity.¹⁴ Thus if oxygenated radicals contribute to the toxicity of the fresh coal dust as measured via hemolysis, the addition of SOD should cause a decrease in the hemolysis. Table IV shows the results of addition of 0.5 mg/ml of SOD to the fresh coal dust samples prior to incubation with the sheep erythrocytes. As before, the hemolysis measurements were made at the dust concentrations of 5 mg/ml and 10 mg/ml. Indeed the addition of SOD causes a significant drop in the hemolytic potential of the fresh coal dust. The results indicate a significant role of the superoxide-based radicals in the hemolysis by coal dust.

Catalase

As an aid in understanding the above results with SOD, we investigated the effect of catalase, an enzyme known to offer protection against the hydrogen peroxide (H_2O_2) toxicity, by breaking down H_2O_2 into H_2O and O_2 . Table IV also includes the hemolysis results in the presence of 0.5 mg/ml of added catalase. It is clearly seen that the addition of catalase decreases the hemolytic activity even more than done by SOD.

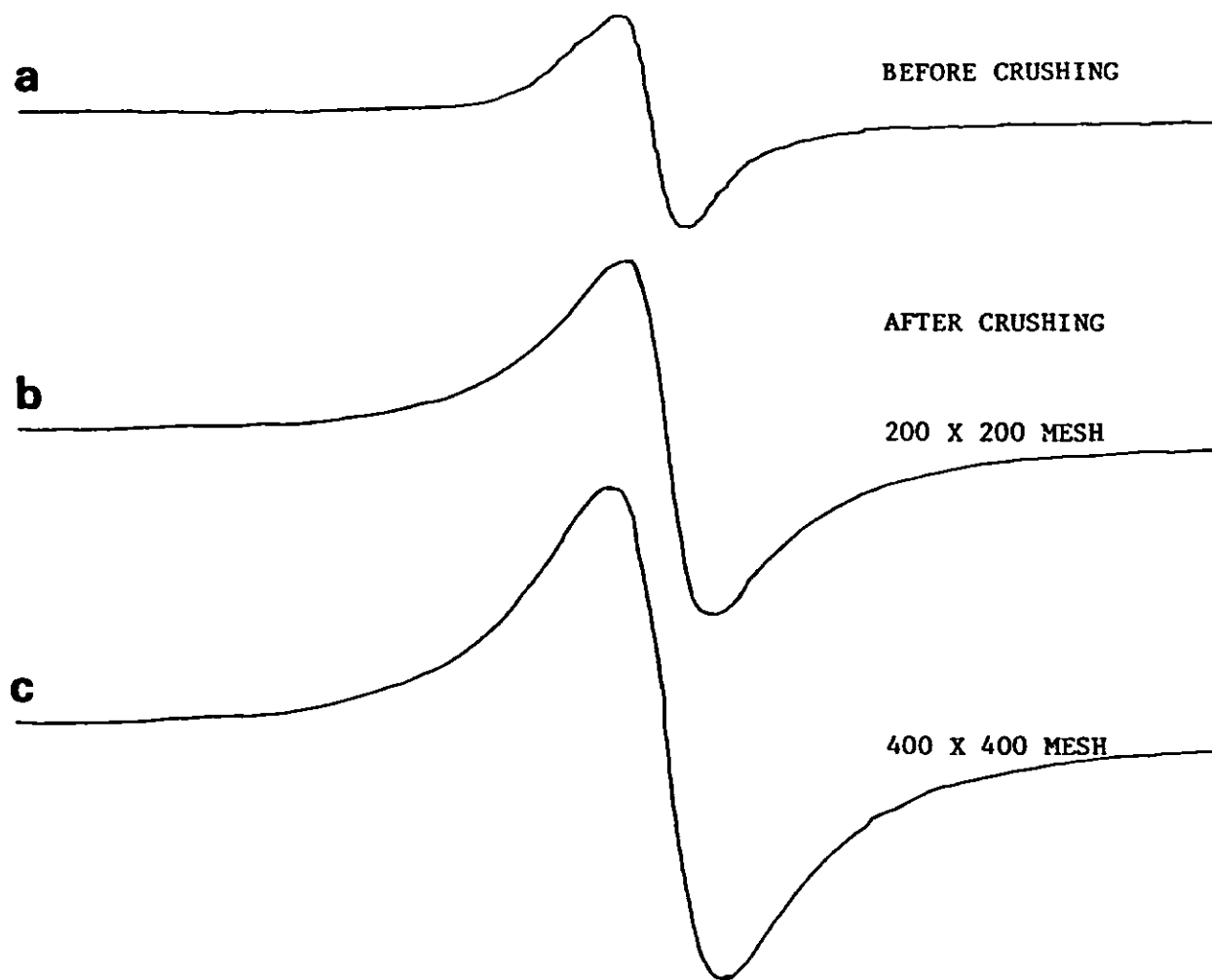

Figure 1. Time dependence of the decay of radicals in air.

Table I

<u>Effect of Crushing on the Anthracite (PSOC-867) Coal</u>		
	<u>Size</u>	<u>Spin/Gram</u>
Before Crushing		4.8×10^{16}
After Crushing	200 x 200 mesh	1.5×10^{17}
Before Crushing		7.9×10^{16}
After Crushing	400 x 400 mesh	4.3×10^{17}

PSOC - 867 (C=95%)

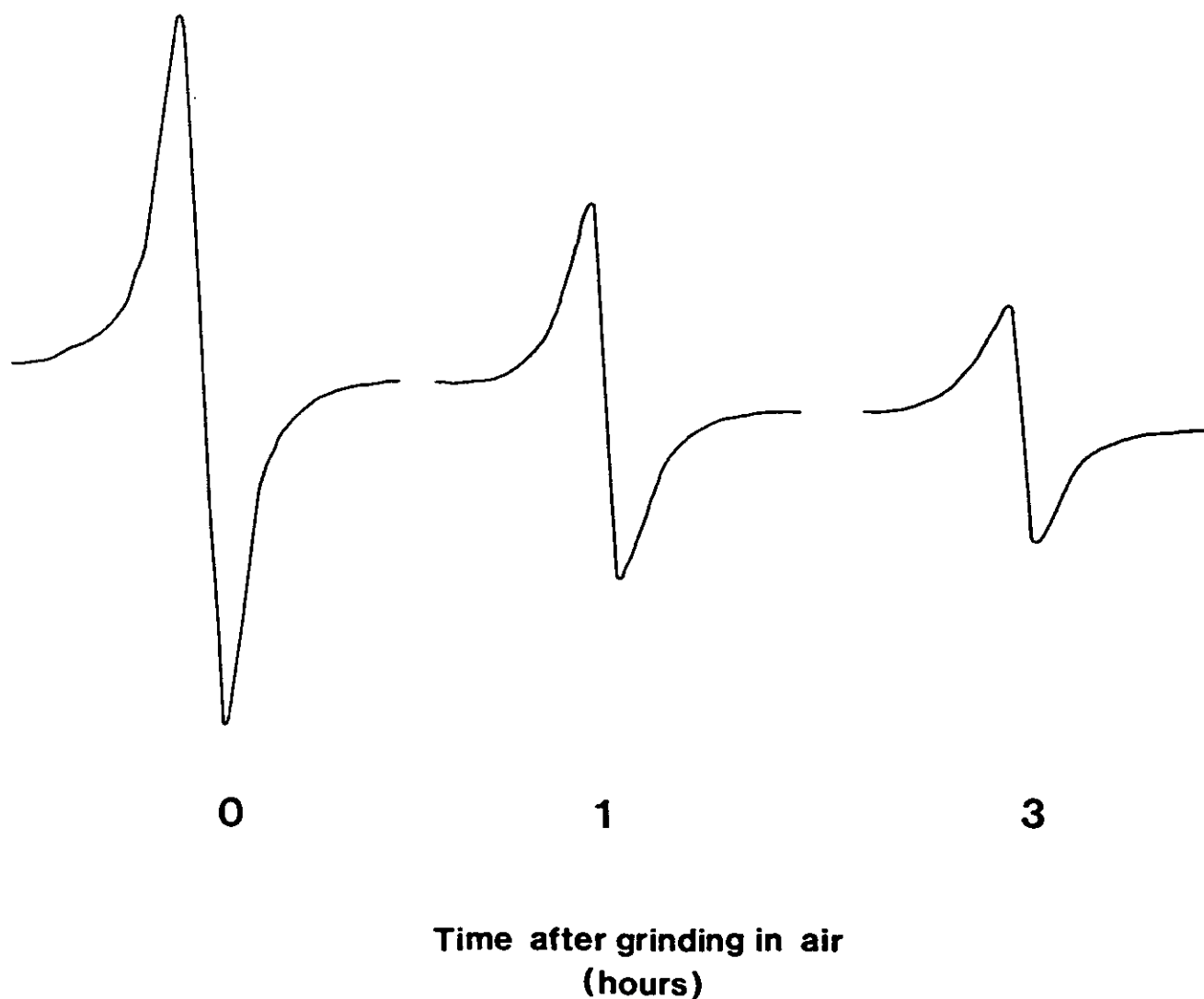

Figure 2. ESR spectra showing the formation of radicals on crushing.

Sodium Benzoate

As a third test, we investigated the hemolytic activity of the fresh dust in the presence of sodium benzoate, a compound often used to specifically quench $\cdot\text{OH}$ radicals in biological systems.¹⁴ Sodium benzoate was added at two different concentrations, 0.1 mg/4 ml and 0.01 mg/4 ml. The results are

presented in Table IV wherefrom it is clear that sodium benzoate decreases the hemolytic activity in a dose-response manner but with much less efficiency than catalase or SOD. These results suggest that the $\cdot\text{OH}$ radicals are not the main species in the mechanism of the membrane cytotoxicity of the fresh anthracite dusts.

Table II

<u>Decay of Radicals in an Anthracite Coal Crushed and Kept in Air</u>	
Time (hours)	Spins/Gram
0	4.28×10^{17}
10	4.33×10^{17}
20	4.44×10^{17}
50	4.31×10^{17}
100	4.07×10^{17}
170	3.35×10^{17}

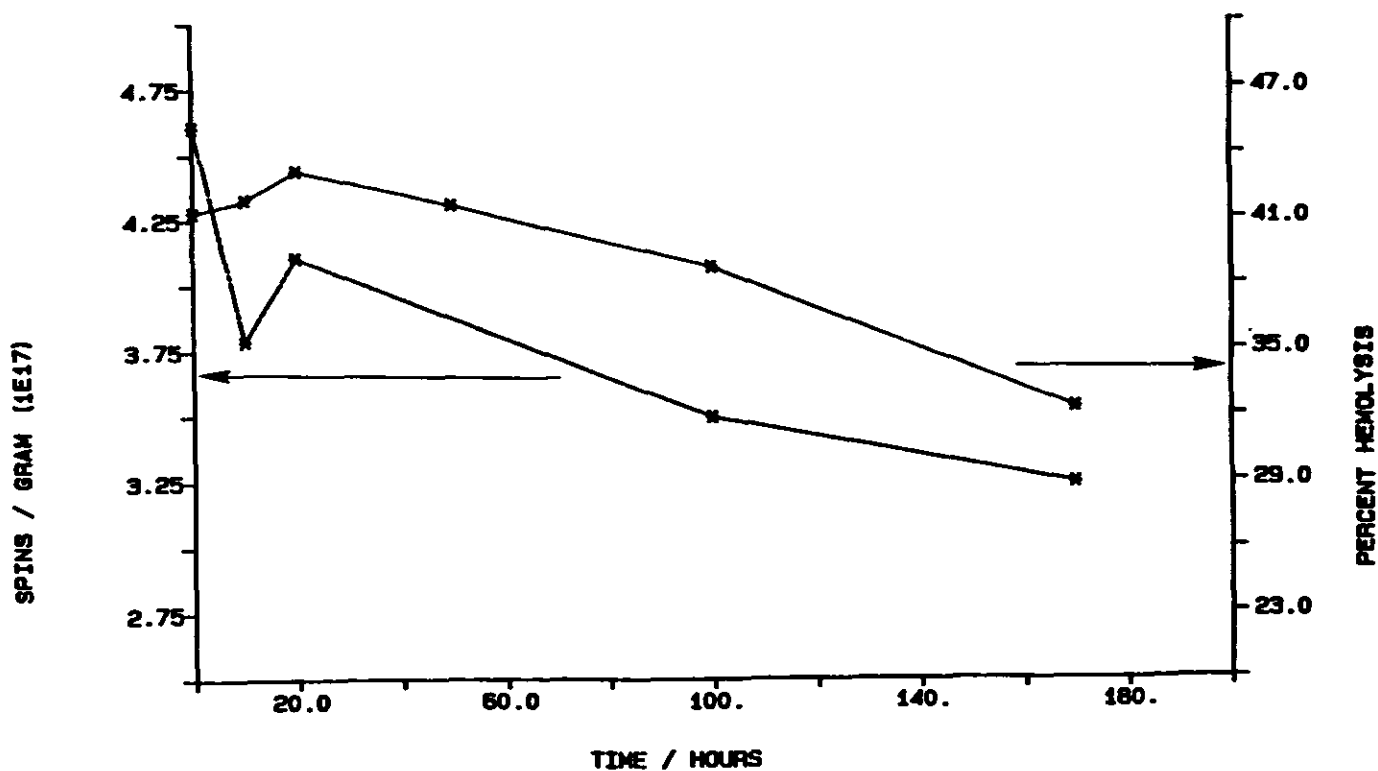

Figure 3. Correlation of the radical concentration measured by ESR, and the toxicity deduced from hemolysis studies of fresh anthracite coal as a function of time.

Table III

Percent Hemolysis Data for an Anthracite Coal
(PSOC-867) Crushed in Air

Time/Hours	Percent Hemolysis			
	5 mg/ml	5 mg/ml	10 mg/ml	10 mg/ml
	AIR	BUFFER	AIR	BUFFER
0	24.5	24.5	45.3	45.3
4	18.5	20.0	35.5	37.5
24	20	21.7	39.3	41.0
96	17.3	20.0	32.0	40.0
176	17.0	20.5	29.0	40.0

Table IV

Effect of SOD, Catalase, and Sodium Benzoate on Hemolysis of Coal Dust

Compound	Concentration	Percent Hemolysis
SOD	5 mg/ml	31.1
	5 mg/ml + SOD	8.7
	10 mg/ml	46.3
	10 mg/ml + SOD	24.3
Catalase	5 mg/ml	29.7
	5 mg/ml + Catalase	10.6
	10 mg/ml	47.2
	10 mg/ml + Catalase	23.3
Sodium Benzoate	5 mg/ml	32.5
	5 mg/ml + 0.1 mg	22.9
	Sodium Benzoate	
	5 mg/ml + 0.1 mg	26.5
	10 mg/ml	45.3
	10 mg/ml + 0.1 mg	31.9
	Sodium Benzoate	
	10 mg/ml + 0.01 mg	38.4
Sodium Benzoate		

Oxygen Atmosphere

In order to further ascertain if oxygen plays a direct role in the cytotoxicity, not involving the mechanism of any oxygenated species, we carried out comparative hemolysis studies of coal dusts particles under flowing nitrogen gas (to exclude oxygen) and, separately, in air. Moreover the

measurements were made for two different particle sizes, 200 x 200 mesh (<40 microns) and 400 by 400 (<25 microns). As shown in Figure 4. The results show that the participation of oxygen is as important to the mechanism of the fresh dust's cytotoxicity as measured by hemolysis, in conformity with the conclusions from the above discussed measurements employing the oxygen radical quenchers.

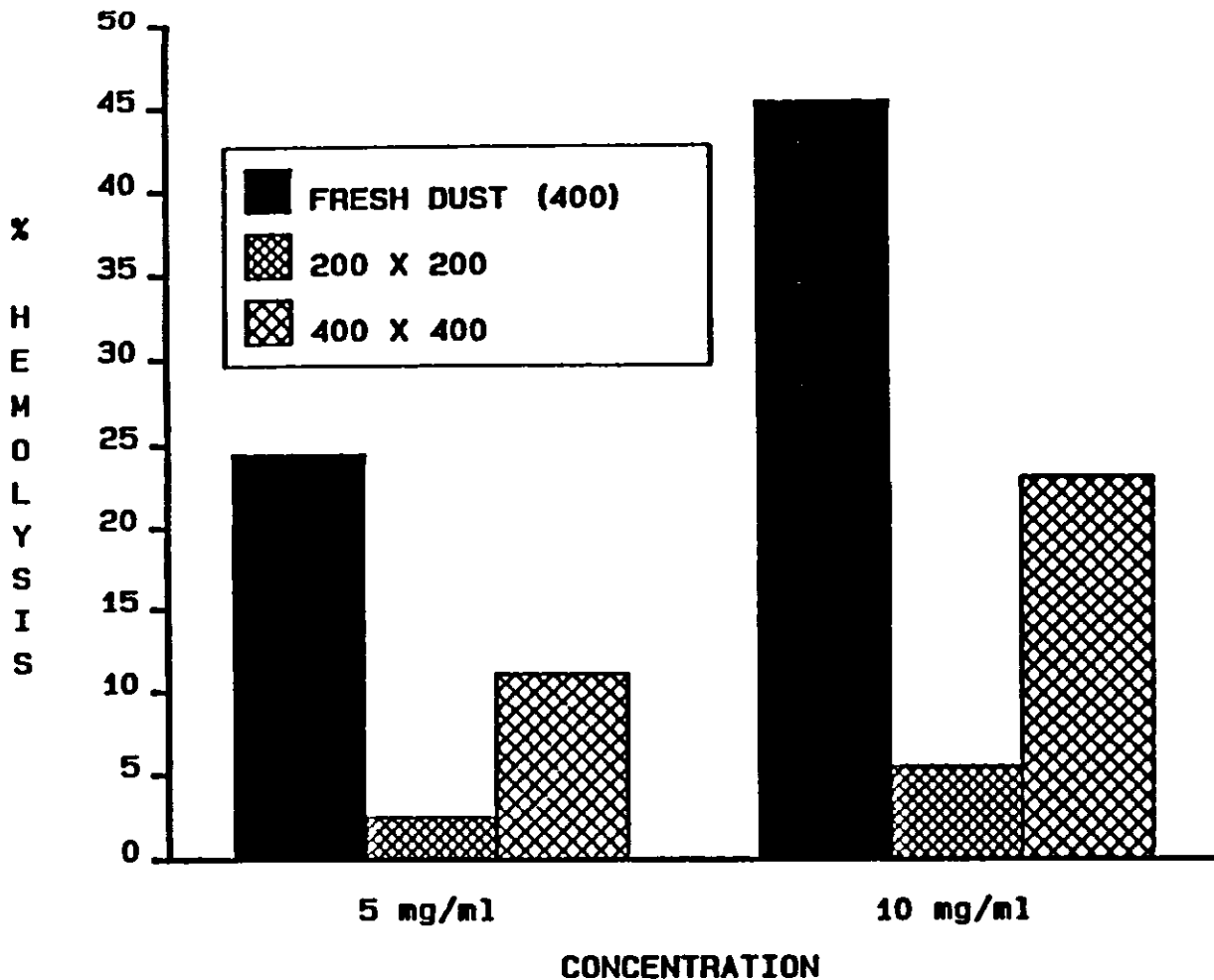

Figure 4. Effect of particle size and nitrogen atmosphere on the hemolysis by the fresh anthracite dust. The data indicates mean of 7 experiments with freshly prepared dust.

Conclusions

The above results suggest that freshly made anthracite coal dusts are more cytotoxic than the 'stale' dusts from the same stock, and that surface oxidation reactions involving free radical sites on the coal particles play a significant role in the dusts cytotoxicity.

REFERENCES

- Hurley, J. F.: Simple Pneumoconiosis and Exposure to Respirable Dust: Relationships from twenty-five years' Research at Ten British Coal Mines. Institute of Occupational Medicine Report, No. TM/79/13 (1979).
- Reisner, M.T.R., Robock, K.: Results in Epidemiological, Mineralogical and Cytotoxicological Pathogenicity of Coal-Mine Dusts. *Inhaled Particles*, Vol. 4, p. 703 (1977).
- Heppleston, A.G.: Changes in the Lungs of Rabbits and Ponies Inhaling Coal Dust Underground. *J. Path. Bact.* 67:349-359 (1958).
- Hatch, G.E., Gardner, D.E., Menzel, D.B.: Stimulation of Oxidant Production in Alveolar Macrophages by Pollutant and Latex Particles. *Environmental Research* 23:121-136 (1980).
- Christian, R.T., Nelson, J.B.: Coal: Response of Cultured Mammalian Cells Corresponds to the Incidence of Coal Workers' Pneumoconiosis. *Environmental Research*, 15:232-241 (1978).
- Christian, R.T., Nelson, J.B., Cady, T.E., Larson, E., Bingham, E.: Coal Workers' Pneumoconiosis: In Vitro Study of the Chemical Composition and Particle Size as Causes of the Toxic Effects of Coal. *Environmental Research*, 20:358-365 (1979).
- Artemov, A.V., Reznik, L.A.: Questions on the Methodology of Biological Investigations of the Fibrogenicity of Coal Dust. *Gib. Tr. Professor Zabol.*, 2:51-55 (1980).
- Vallyathan, V., Schwegler, D., Reasor, M., Stettler, L., Green, F.Y.H.: Comparative In Vitro Cytotoxicity and Relative Pathogenicity of Mineral Dusts: paper presented at the International Symposium on Inhaled Particles, Cambridge, England (1985) (in press).
- Dalal, N.S., Suryan, M.M., Vallyathan, V., Green, F.Y.H., Jafari, B., Wheeler, R.: Detection of Reactive Free Radicals in Fresh Coal Mine Dust and Its Implications to Pneumoconiosis. Paper presented at the International Symposium on Inhaled Particles, Cambridge, England (1985).
- Dalal, N.S., Suryan, M.M., Jafari, B., Shi, X., Vallyathan, V., Green, F.Y.H.: Electron Spin Resonance Detection of Reactive Free Radicals in Fresh Coal Dust and Quartz Dust and Its Implications to Pneumoconiosis and Silicosis. Proc. Int. Symp. on Respirable Dusts in the Mineral Industries, Pennsylvania State University, University Park, PA (USA). pp. 24-29, (1986).
- Jafari, B.: EPR-Biochemical Studies of Free Radicals in Pneumoconiosis. MS Thesis, Chemistry Department, West Virginia University Morgantown, WV (USA), (1986).
- Harringt, J.S., Miller, K., McNab, G.: Hemolysis by Asbestos. *Environ. Res.* Vol. 4, 95-117 (1971).
- Retcofsky, H.L.: Magnetic Resonance Studies of Coal. *Coal Science*, 1:43-82 (1982) and references therein.
- Bohinski, R.C.: Modern Concepts in Biochemistry. McGraw Hill, Chapter V (1980).

ACKNOWLEDGEMENTS: This research has been supported by the Department of the Interior's Mineral Institute program administered by the Bureau of Mines through the Generic Mineral Technology Center for Respirable Dust under the grant number G1135142.

EVIDENCE FOR FREE RADICAL INVOLVEMENT IN THE TOXICITY AND CARCINOGENICITY OF CHROMATE DUSTS

XIANGLIN SHI • Nar S. Dalal

Department of Chemistry, West Virginia University, Morgantown, WV 26506, USA

INTRODUCTION

Epidemiologic studies of workers in chromate-ore related industries,¹⁻³ and stainless steel welding and related occupations⁴ have shown that they have about 20-40 times higher risk of throat or respiratory track cancer than controls. Although the actual carcinogenic substances were not identified in these statistical studies, Cr(VI) compounds (for example, calcium chromate, zinc chromate, and lead chromate) were implicated as the causative agents, whereas Cr(III) compounds were not suspected as carcinogens.⁵ These suggestions were supported by laboratory studies wherein many Cr(VI) compounds produced sarcomas at the implant or injection sites.^{1,5} Squamous cell carcinomas and adenocarcinomas closely resembling human lung cancer were induced by intrabronchial implants of calcium chromate in rats,^{6,7} whereas Cr(III) oxide and Cr(III) sulfate did not induce any tumor formation.^{6,7}

While the mechanism of the chromate-induced carcinogenicity is not fully understood, it is generally thought⁸ that it involves some damage to DNA. Specifically, it has been reported that: a) the chromate ion, henceforth referred to as chromate, can pass through the cell membrane and enter the cell while Cr(III) does not,⁹ b) chromate does not interact with either native or denatured DNA¹⁰ while Cr(III) does,¹¹ and c) the final Cr-DNA complex isolated from cellular reactions of chromate is Cr(III)-DNA, with Cr(III) binding to the phosphate groups.^{12,13} Thus the important question is: since Cr(III) cannot pass through the membranes, how does Cr(III)-DNA complex form? For this to happen, Cr(VI) must be reduced to its lower oxidation states,¹⁴ ultimately to Cr(III), by some reductants in the cellular environment. Unless this reduction occurs, the DNA would not be damaged and therefore no chromate carcinogenicity would ensue. Thus the reduction of chromate to its lower oxidation states seems to be a key step in the chromate carcinogenicity.¹⁵ One of the major reductants in cellular environments is thought to be glutathione (GSH), both outside and inside the cells.¹⁶⁻¹⁸ Some evidence for the role of GSH in the chromate toxicity was provided by recent studies showing that exposure of hamster cells to non-toxic levels of added selenite increases the levels of GSH as well as the Cr(VI)-induced DNA strand breaks,¹⁹ and that such DNA strand breaks in hepatocytes also change in direct proportion to the GSH content.^{20,21} These observations were interpreted as implying that the reduction of chromate by GSH to some reactive intermediate is an important step in the chromate carcinogenicity.^{20,21} In the present undertaking²² we have used electron spin reso-

nance (ESR) and spin-trap methodology to investigate the reduction of chromate by GSH and find evidence for the involvement of the glutathionyl radical (GS·) as well as Cr(V)-intermediates.

MATERIALS AND METHODS

ESR spectra were obtained at X-band (~9.7 GHz) using a Bruker ER200D ESR spectrometer. The magnetic field was calibrated with a self-tracking NMR Gaussmeter (Bruker, Model ER035M) and the microwave frequency was measured with a Hewlett-Packard (Model 5340A) frequency counter. The spin probes, α -(4-pyridyl-1-oxide)-N-tert-butyl nitron (4-POBN) and 5,5-dimethyl-1-pyrroline-1-oxide (DMPO), were purchased from Aldrich, and used without further purification since very weak or no spin-adduct signals were obtained from the purchased sample when used alone. $K_2Cr_2O_7$, purchased from Fisher, was used as a source for the chromate ion. All measurements were made at room temperature.

RESULTS AND DISCUSSION

Figure 1 shows some typical ESR spectra obtained. While an aqueous solution of 0.1 M spin trap, 4-POBN, containing either chromate or GSH alone, did not give any ESR signal, mixtures of chromate, GSH and 4-POBN together gave a spectrum which was composite of the spin adduct signal (sharp doublets of triplets) and those of Cr(V) (the broad peaks at $g = 1.995$ and $g = 1.985$)²³⁻²⁶ (Figure 1a). About ten minutes later, when the signal from Cr(V) had decayed, a clear spectrum at $g = 2.0061$, consisting of only doublets of triplets, was obtained, which is assigned to the 4-POBN-GS adduct because of its strong similarity to the spectrum reported earlier²⁵ for the same adduct, the GS· radical being produced via reaction of GSH with α -chromanoxyl radical. The analysis of the spectrum (doublets of triplets) in Figure 1a gave the nitrogen hyperfine coupling $a_N = 15.0$ G and proton hyperfine coupling $a_H = 2.3$ G, which compare well with those ($a_N = 15.13$ G and $a_H = 2.32$ G) reported earlier.²⁵

Additional support for this identification was obtained from spin-trap studies with DMPO. The ESR spectrum obtained using DMPO was composite of that of the spin adduct, a 1:2:2:1 quartet, and that of Cr(V), the broad peaks at $g = 1.995$ and $g = 1.985$, Figure 1b. The analysis of the spin-adduct spectrum gave $a_N = 15.2$ G and $a_H = 15.9$ G. These values are fairly close to those ($a_N = 15.4$ G and $a_H = 16.2$ G) reported earlier^{26,27} for the DMPO-GS spin adduct.

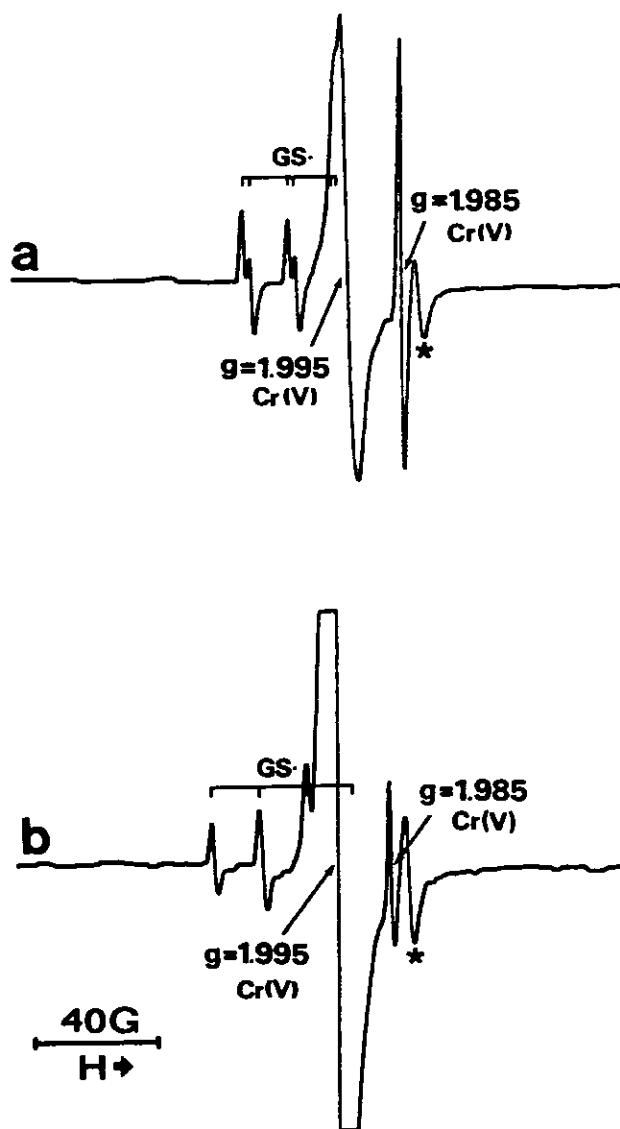

Figure 1. ESR spectra recorded 2 minutes after mixing a solution of $[K_2Cr_2O_7] = 0.015$ M, $[glutathione] = 0.15$ M; (a) $[4-POBN] = 0.1$ M; $pH = 4.0$; (b) $[DMPO] = 0.1$ M; $pH = 7.2$. The asterisks indicate minor Cr(V) species.

Moreover the spin-adduct spectrum showed a rapid decrease with time essentially as described previously.^{26,27}

The spin-trap studies showed that an increase in the amount of GSH causes to an increase in the spin adduct ESR signals until the intensity leveled off at a molar ratio of about fifteen to one of GSH to $K_2Cr_2O_7$. No spin-adduct ESR signal was detected for the molar ratio of less than one. We also find direct evidence for the formation of a fairly long-lived Cr(V) intermediate, but at molar ratios of higher than one of GSH to $K_2Cr_2O_7$, in contradiction to an earlier report.¹⁶ In agreement with other studies,^{23,24} however, several different Cr(V) complexes were observed depending on the

reaction conditions, as indicated by asterisks in Figure 1. We were able to isolate the dominant, $g = 1.995$, species with a yield of about 50 percent. The measured g -values for the powder spectrum are $g_{\parallel} = 2.007$ and $g_{\perp} = 1.989$, with little variation with temperature from 115 to 310 K. These values are typical of Cr(V) solids.²⁸ ESR measurements on samples redissolved in water gave spectra identical with those from the reaction mixtures (before isolation), showing the stability of this isolated product, and reaffirming its Cr(V) identification.

The above results also help understand two recent reports^{20,21} showing that increased levels of GSH in the cells result in increased DNA damage by Cr(VI). Our detection of the formation of $GS\cdot$ and Cr(V) at high GSH levels, as true for the *in vivo* conditions,¹⁰ suggests that the synergistic reactions of the Cr(V) intermediate and $GS\cdot$ are perhaps responsible for the increased Cr(VI)-induced DNA strand breaks at high GSH levels. It is thus felt that these results open up new avenues for understanding the mechanism of chromate-related carcinogenesis.

REFERENCES

1. Enterline, P.E.: Respiratory Cancer among Chromate Workers. *J. Occup. Med.* 16:523-526 (1974).
2. Langard, S., Norseth, T.: A Cohort Study of Bronchial Carcinomas in Worker Producing Chromate Pigments. *Br. J. Ind. Med.* 32:62-65 (1975).
3. Hedenstedt, A., Jensen, D., Lidesten, B.M., Ramel, C., Rannug, U., Stern, R.M.: Mutagenicity of Fume Particles from Stainless Steel Welding. *Scand. J. Work, Environ. Health* 3:203-211 (1977).
4. Baetjer, A.M.: Pulmonary Carcinoma in Chromate Workers. *Arch. Ind. Hyg. Occup. Med.* 2:487-504 (1950).
5. Furst, A., Schlauder, A.M., Sasmore, D.P.: Tumorigenic Activity of Lead Chromate. *Cancer Res.* 36:1779-1783 (1976).
6. Lane, B.P., Mass, M.J.: Carcinogenicity and Cocarcinogenicity of Chromium Carbonyl in Heterotopic Tracheal Crafts. *Cancer Res.* 37:1476-1479 (1977).
7. Stoner, G.D., Shimikn, M.B., Troxell, M.C., Thompson, T.C., Terry, L. S.: Test for Carcinogenicity of Metallic Compounds by the Pulmonary Tumor Response in Strain A Mice. *Cancer Res.* 36:1744-1747 (1976).
8. Biabchi, V., Celotti, L., Lanfranchi, G., Majone, F., Montaldi, A., Sponaza, G., Tamino, G., Venier, P., Zaevtedeschi, A., Levis, A.G.: Genetic Effects of Chromium Compounds. *Mutat. Res.* 117:279-300 (1983).
9. Jennette, K.W.: Chromate Metabolism in Liver Microsomes. *Biol. Trace Element Res.* 1:55-62 (1979).
10. Tsapakos, M.J., Wetterhahn, K.E.: The Interaction of Chromium with Nucleic Acids. *Chem.-Biol. Interactions.* 46:265-277 (1983).
11. Frenderson, M.B., Zeff, L.A.: The Effect of Cr(III) upon the Thermal Denaturation of DNA. *Bioorganic Chem.* 13:24-33 (1985).
12. Huff, J.W., Sastry, K.S., Gordon, M.P., Wacker, W.E.C.: The Action of Metal Ions on Tobacco Mosaic Virus Ribonucleic Acid. *Biochemistry* 3:501-506 (1964).
13. DePhamphiles, M.L., Cleland, W.W.: Preparation and Properties of Chromium(III)-Nucleotide Complexes for Use in the Study of Enzyme Mechanism. *Biochemistry* 12:3714-3724 (1973).
14. Tasapakos, M.J., Hampton, T.H., Wetterhahn, K.E.: Chromium(VI)-Induced DNA Lesions and Chromium Distribution in Rat Kidney, Liver, and Lung. *Cancer Res.* 43:5662-5667 (1983).
15. Connett, P.H., Wetterhahn, K.E.: Metabolism of the Carcinogen Chromate by Cellular Constituents. *Structure and Bonding*; 54:93-124 (1983).
16. Connett, P.H., Wetterhahn, K.E.: In Vitro Reaction of Carcinogen Chromate with Cellular Thiols and Carboxylic Acids. *J. Am. Chem. Soc.* 107:4282-4288 (1985).
17. Connett, P.H., Wetterhahn, K.E.: Reaction of Chromium(VI) with Thiols: pH Dependence of Chromium(VI) Thiol Ester Formation. *J. Am. Chem. Soc.* 108:1842-1847 (1986).
18. Weigand, H.J., Ottenwalder, H., Bolt, H.M.: The Reduction of

- Chromium to Chromium(III) by Glutathione: An Intracellular Redox Pathway in the Metabolism of the Carcinogen Chromate. *Toxicology* 33:341-348 (1984).
19. Sugiyama, M., Ando, A., Furuno, A., Furlong, N.B., Hidaka, T., Ogura, R.: Effects of Vitamin E, Vitamin B₂ and Selenite on DNA Single Strand Breaks Induced by Sodium Chromate(VI). *Cancer Lett.* 38:1-7 (1987).
 20. Wetterhahn, K.E., Connett, P.H.: Metabolic Action and DNA Damage Were Important to the Carcinogenicity of Cr(VI). *Trace Subst. Environ. Health* 18:154-162 (1984).
 21. Cupo, D.Y., Wetterhahn, K.E.: Modification of Chromium(VI)-Induced DNA Damage by Glutathione and Cytochromes P-450 in Chicken Embryo Hepatocytes. *Proc. Natl. Acad. Sci. USA* 82: 6755-6759 (1985).
 22. Preliminary results have been presented at the International Conference on Medical, Biochemical and Chemical Aspects of Free Radicals. April 9-13, 1988, Kyoto, Japan.
 23. O'Brein, P. Chromium(V) Can Be Generated in the Reduction of Chromium(VI) by Glutathione. *Inorg. Chim. Acta* 108:L19-20 (1985).
 24. Goodgame, D.M.L., Joy, A.M.: Relatively Long-Lived Chromium(V) Species Are Produced by the Action of Glutathione on Carcinogenic Chromium(VI). *J. Inorg. Biochem.* 26:219-224 (1986).
 25. Niki, E., Tsuchiya, J., Tanimura, R., Kamiya, Y.: Regeneration of Vitamin E from Alpha-Chromanoxyl Radical by Glutathione and Vitamin C. *Chemistry Lett.* 789-792 (1982).
 26. Harman, L.S., Carver, D.K., Schreiber, J., Mason, R.P.: One- and Two-Electron Oxidation of Reduced Glutathione by Peroxidase. *J. Biol. Chem.* 261:1642-1648 (1986).
 27. Stock, B.H., Schreiber, J., Guenat, C., Mason, R.P., Bend, J.R., Eling, T.E.: Evidence for a Free Radical Mechanism of Styrene-Glutathione Conjugate Formation Catalyzed by Prostaglandin H Synthase and Horseradish Peroxidase. *J. Biol. Chem.* 261:15915-15922 (1986).
 28. Dalal, N.S., Millar, J.M., Jagadeesh, M.S., Sechra, M.S.: Paramagnetic resonance, Magnetic Susceptibility, and Antiferromagnetic Exchange in a Cr³⁺ Paramagnet: Potassium Perchromate. *J. Chem. Phys.* 74:1916-23 (1981).

Abbreviations used here: GSH, glutathione; GS·, glutathionyl radical; 4-POBN, α-(4-pyridyl-1-oxide)-N-tert-butyl nitron; DMPO, 5,5-dimethyl-1-pyrroline-1-oxide; ESR, electron spin resonance.

THE SINGLE BREATH DIFFUSING CAPACITY MEASUREMENT AS A PREDICTOR OF EXERCISE INDUCED OXYGEN DESATURATION IN PATIENTS WITH SILICOSIS

K. RATKALKAR, M.D. • N. Rambaran, M.D. • E. Mezcic, M.D.
• J. T. Nicewicz, M.D. • D. M. F. Murphy, M.D.

Deborah Heart and Lung Center, Browns Mills, New Jersey 08015, USA

The single breath diffusing capacity at rest is frequently found to be abnormal in patients with silicosis.¹⁻³ Little correlation exists between measurements of diffusing capacity by the steady state method and arterial oxygen tension.⁴ Patients with conglomerate silicosis frequently show a reduced resting single breath diffusing capacity associated with exercise induced hypoxemia.⁵ In patients with chronic obstructive pulmonary disease, a measurement of the resting single breath diffusing capacity greater than 55% of predicted has been shown to be specific in excluding desaturation on exercise.⁶ In shipyard workers exposed to asbestos, a diffusing capacity below 70 percent of predicted was shown to be associated with abnormal arterial oxygen tension and gas exchange. Abnormalities in gas exchange on exercise were found also in some subjects with diffusing capacities greater than 70 percent of predicted.⁷ We undertook the current study to determine the capacity of the single breath diffusing capacity measurement to predict exercise induced hypoxemia in patients with both simple and conglomerate silicosis.

METHODS

We studied nine subjects with silicosis whose diagnosis was based on occupational history, and chest radiography. All subjects had chest roentgenograms showing simple or conglomerate disease. Each subject also had a measured arterial oxygen tension value greater than 55 mmHg at rest. All subjects undertook standard pulmonary function and exercise testing. The pulmonary function tests included flow rates, lung volumes and single breath diffusing capacity measurements using standard techniques. Progressive exercise testing was performed on a treadmill using standard incremental protocols. Indices monitored during exercise in all subjects included the electrocardiogram, workload, minute ventilation, breathing frequency, oxygen consumption ($\dot{V}O_2$ ml/kg/min), carbon dioxide production ($\dot{V}CO_2$ ml/kg/min). Oxygen and carbon dioxide levels were monitored using rapid response analyzers (Beckman OM-11 and Beckman LB-11). Arterial blood gases were measured both at rest and at peak exercise just before the termination of the exercise test using air blood gas analyzer (1L1303). Data analyzed at the breaking point of exercise were maximum heart rate, workload, maximum breathing frequency, maximum minute ventilation, maximum oxygen consumption ($\dot{V}O_2$ max ml/kg/min); expired carbon dioxide percent, and dead space/tidal volume VD/V_T ratio.

Arterial samples were drawn from an indwelling radial artery cannula placed at rest. The samples were placed in ice and analyzed immediately. We examined whether an abnormal resting single breath diffusing capacity defined as equal to or less than 80 percent of predicted would predict in individual subjects altered gas exchange during exercise. A decrement in PaO_2 of greater than 5 torr on exercise and/or fall in oxygen saturation of 5 percent or greater was considered significant.

RESULTS

Of the nine subjects, four had simple silicosis and five conglomerate silicosis. Their ages ranged 44 to 72 years. Five out of the nine subjects were smokers. All subjects performed a progressive incremental exercise test, and they achieved a mean workload of four METS. Two out of nine subjects had a normal resting single breath diffusing capacity (greater than 80 percent of predicted) and seven out of nine subjects had abnormal resting single breath diffusing capacity (less than 80 percent of predicted). One of the two subjects with a normal resting single breath diffusing capacity had a decrement in arterial oxygen tension of 11 torr on exercise and seven out of the nine subjects with a resting single breath diffusing capacity less than 80 percent of predicted had decrements in arterial oxygen tension ranging from 5–20 torr on exercise. Three out of nine subjects with conglomerate silicosis had decrements in oxygen saturation of more than 5 percent on exercise. The alveolar-arterial oxygen difference increased on exercise in all seven subjects with abnormal resting single breath diffusing capacity measurements, by a mean value of 15.6 torr. Abnormalities in VD/V_T ratio (defined as greater than 30 percent) were seen in all nine subjects on exercise. One of the nine subjects with a high resting VD/V_T percent ratio of 51.8 had a decrement in VD/V_T percent ratio to 37.8 on exercise.

The $\dot{V}O_2$ max in all nine subjects ranged from 5.2 to 25.4 ml/Kg/min with a mean $\dot{V}O_2$ max of 17.02 ml/Kg/min. The exercise test was terminated in all subjects by complaints of severe dyspnea.

DISCUSSION

In early cases of silicosis, arterial blood oxygen desaturation is usually not present at rest,⁵ however at high exercise loads a considerable proportion of silicosis patients show some degree of arterial blood desaturation.⁶

Table I
Anthropometric Characteristics of Patients

	AA	AW	CL	LJ	KO	NS	KE	HH	RJ
Sex	M	M	M	M	M	M	M	M	M
Age (yrs)	71	55	67	56	72	70	44	69	52
Height (cm)	169	179	175	170	170	171	175	177	173
Weight (kg)	75	86	69	98	67	74	113	80	70
Smoker (S) Non Smoker (NS)	NS	S	S	NS	S	NS	S	S	NS
Smoker Pack Years	—	30	75	—	5 bowls per day x 25 yrs.	—	10	30	—
Type of Occupational Exposure	Grinder Carpenter libbing heavy duty	Mechanic	Furniture Shop Mfg	Coal Miner	Painter Blacksmith Grinding steels	Miner Blacksmith Steelworker Pile on ship	Auto Wash Jat Wash Handwasher	Asphalt Steel Cast Construction	Furniture Steel Miner
Exposure Years	25	20	30	9	40	20	22	45	21

	DLCO% PRED	PaO ₂ REST mmHg	PaO ₂ ex (mmHg)	PaO ₂ mmHg
1	56.0	82.0	64.0	18.0
2	72.0	86.0	77.0	9.0
3	44.0	67.0	60.0	7.0
4	80.0	85.0	72.0	13.0
5	100.0	73.0	73.0	0.0
6	56.0	73.0	60.0	13.9
7	90.0	93.0	82.0	11.0
8	75.0	64.0	59.0	5.0
9	55.0	93.0	82.0	11.0

	FEV1/ FVC%	TLC% PRED	VO ₂ MAX ml/Kg/min	UD/UT%
1	73.0	61.0	15.9	39.9
2	79.0	62.0	23.0	42.3
3	93.0	44.0	15.1	41.6
4	79.0	90.0	18.5	37.8
5	64.0	125.0	25.4	51.7
6	76.0	64.0	16.1	42.5
7	84.0	75.0	23.4	48.3
8	30.0	108.0	5.2	64.4
9	73.0	52.0	10.6	46.2

In a similar study performed in shipyard workers exposed to asbestos,⁶ a diffusing capacity at rest of below 70 percent of predicted was usually associated with gas exchange abnormalities. However, in some subjects with diffusing capacities above 70 percent of predicted, VD/V_T ratio, abnormal values for arterial oxygen tension and the alveolar-arterial difference in oxygen tension were found.

In our study three of the subjects with resting single breath diffusing capacity above 70 percent but below 80 percent of predicted had decrements in arterial oxygen tension in the range of 5-13 torr. One subject with single breath diffusing capacity of 90 percent of predicted had a decrement in arterial oxygen of 11 torr. Four subjects with single breath diffusing capacities below 70 percent of predicted had decrements in arterial oxygen on exercise in the range of 11 to 20 torr.

Abnormalities in gas exchange as shown by alveolar-arterial difference in oxygen and dead space/tidal volume ratio were seen in all our subjects during exercise. These abnormalities in gas exchange may be caused by increased perfusion to lung units without proportional increase in ventilation causing hypoxemia thus increasing the alveolar-arterial oxygen difference. Conversely the inability of perfusion to increase appropriately to the well ventilated lung units results in abnormally high dead space/tidal volume ratio and high arterial-

end tidal difference in carbon dioxide. Our study revealed gas exchange abnormalities similar to those seen in subjects exposed to asbestos.⁶ We also observed high dead space/tidal volume ratios on exercise which could not be predicted by resting single breath diffusing capacity measurements. Thus our results indicate that in seven of nine subjects with silicosis, resting single breath diffusing capacity equal to or less than 80 percent of predicted a decrement in arterial oxygen tension and/or oxygen saturation occurred with exercise.

In summary, in a small number of silicotic subjects, the single breath diffusing capacity measurement at rest appears to predict exercise induced decrements in arterial oxygen tension and/or oxygen saturation. Abnormalities in gas exchange as shown by increased alveolar-arterial oxygen difference and dead space/tidal volume ratios were seen in all subjects during exercise.

REFERENCES

1. Nicaise, R., Vereerstraeten, J., and DeClereq, F.: The diffusion capacity at rest and during exercise in pneumoconiosis. *Select Papers*. 10:70-79, (1967).
2. Cugell, D.W., et al.: Carbon monoxide diffusing capacity during steady exercise. *Am. Rev. Tuberc.*, 74:317, (1956).

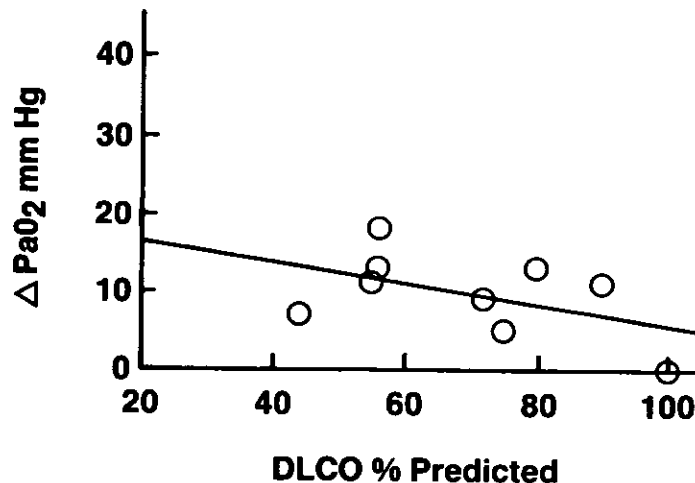
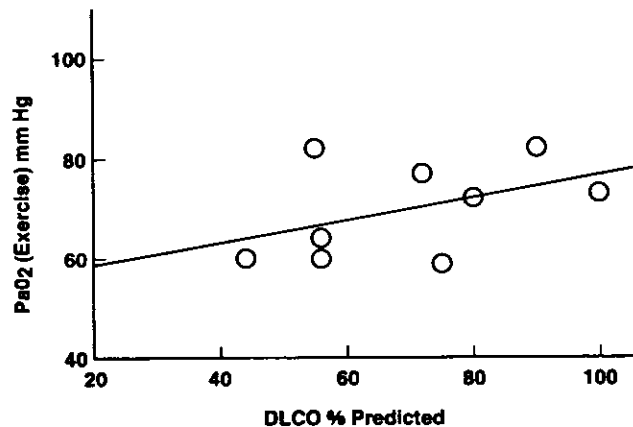
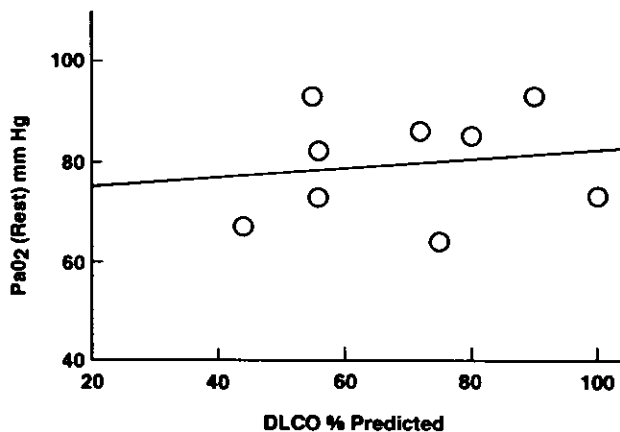

3. Kanagami, H., et al.: Studies on the pulmonary diffusing capacity by the carbon monoxide breath holding technique II. Patients with various pulmonary diseases. *Acta Med. Scand.*, 169:595, (1961).
4. Nissardi, G.P., et al.: Lung diffusing capacity on effort in normal and silicotic subjects. *Lav. Umano.*, 17:397-414, (1965).
5. Becklake, M.R., et al.: Lung function in silicosis of the Witwaterstand gold miner. *Am. Rev. Tuberc.*, 62:29, (1950).
6. Owens, G.R., et al.: The diffusing capacity as a predictor of arterial oxygen desaturation during exercise in patients with chronic obstructive pulmonary disease. *New Eng. J. Med.*, Vol. 310, No. 19, pp. 1218-1221, (1984).
7. Sue, D.Y., et al.: Diffusing capacity for carbon monoxide as a predictor of gas exchange during exercise. *New Eng. J. Med.*, Vol. 310, No. 21, pp. 1301-1306, (1987).

THE RELATIONSHIP BETWEEN ASBESTOS BODIES, SERUM IMMUNOGLOBULIN LEVELS AND X-RAY CHANGES IN ASBESTOS WORKERS

V. CVETANOV • J. Karadžinska • J. Vasevski • N. Ežova • E. Stikova • A. Vrencovski

Institute for Occupational Health, Skopje, Yugoslavia

Several authors have pointed to the immunological disorders which are the result of the fibrogenous effect of asbestos dust; this is a well-known phenomenon on which quite a few references exist.^{1,4,5}

This is why we wanted to establish the possible relationship between the X-ray changes, the number of asbestos bodies and the level of serum immunoglobulins in a group of asbestos workers.

MATERIAL AND METHODS

Out of 79 workers of the asbestos section in the factory for asbesto-cement products, 52 persons were studied. The examined workers were divided into three groups: Group 1 of the workers directly exposed to asbestos, with radiographic changes suggesting asbestosis, Group 2 of the workers also directly exposed to asbestos but without X-ray changes, and Group 3 of the workers who were not directly involved in the process of production. The lungs and the pleura of all the examined workers were x-rayed in PA projection. In all the studied workers the presence of asbestos bodies in the sputum was determined. The immunological status is concerned with the evaluation of the serum immunoglobulin levels (IgG,M,A) on RID plates.

For the evaluation of the results obtained adequate statistical methods X^2 test and Student t-test were applied.

RESULTS AND DISCUSSION

In all the studied workers (fifty-two of them) the presence of asbestos bodies in the sputum was determined, on the native microscopic slide. Their number varied from 1 of 2 to over 20 within one field of vision. Most of them, as much as 36 of them had one to five asbestos bodies in a single (one) field of vision.

The statistical analysis pointed to the fact that there is no statistically significant difference between the groups with respect to the number of asbestos bodies in the sputum. Also, the statistical evaluation proved that there is no significant difference between the workers with radiographic (X-ray) changes suggesting asbestosis and those with normal radiographic findings (groups 2 and 3) with respect to the number of asbestos bodies.

This is an additional proof that the presence of asbestos bodies in the sputum is just a verification of a person's exposure to asbestos.

As far as the immunological status is concerned, with the evaluation of the level of the three classes of immunoglobulins: IgG, IgM and IgA, we obtained the following results:

In Group 1 (11 workers) workers with radiographic changes suggesting asbestosis, with respect to the immunoglobulin type G in 10 persons the level of the serum IgG was above normal and in one worker it was within normal. On one worker only belonging to this group the level of IgM was higher, and also, in one worker only the level of IgA was lower.

In group 2, including workers directly exposed to asbestos, while without radiographic changes, that is 34 of them, in two persons higher level of IgG was determined, in one person the level of IgM was lower and in two workers the level of IgA was higher.

In Group 3, which included workers in the asbestos section of the factory who were not directly exposed to asbestos dust, the level of IgG in all workers was within normal, the level of IgM was lower in one worker, the level of IgA was higher in one worker, and in one worker the level of this type of immunoglobulin was lower.

In the process of the evaluation of the immunological status of the examined workers, the mean value of the three classes of serum immunoglobulins was calculated, as well as the significance of the differences in the mean values among individuals, previously selected, workers.

As part of the statistic evaluation of the obtained results, the significance of the differences in the mean values of particular classes of immunoglobulins were also determined in separate groups of workers.

The Student t-test showed a statistically significant difference in the mean values of IgG between Group 1 and Group 2, Group 2 and Group 3, and Group 1 and Group 3.

With respect to the M and A type of immunoglobulins, no statistically important difference in the mean values was determined either.

Since we have not noticed any significant deviations in the level of IgM and IgA, neither in the groups nor in the individuals, our research concerning the relationship among the number of asbestos bodies, radiographic changes suggesting pneumoconiosis and the immunological status has

been reduced to the relationship between asbestos bodies radiographic changes and the IgG type.

The X^2 test did not point to any statistically significant difference between workers with an increased level of IgG and those with normal or decreased level of this type of Ig in serum, all this of course with respect to the number of asbestos bodies.

This statistic evaluation indicated that there is a statistically important number of workers with radiographic changes in whom the level of IgG is increased, if compared to the number of workers without pneumoconiosis.

Numerous studies point to immunological disorders that are directly or indirectly connected with exposure to asbestos.^{1,2}

Pernis in his research suggested that these immunological changes pointed to the fact that asbestosis, similar to silicosis included in its pathomechanisms immunological reactions as well.⁴

The slow destruction of macrophages can be suspected as a factor contributing to pneumofibrosis.³ It is believed that

the very same mechanism causes immunological disorders in persons exposed to asbestos.

CONCLUSION

No connection between asbestos bodies in sputum, radiographic changes and the immunological status in the studied workers has been established. The obtained results indicated the statistically important increase in the level of IgG in Group 1, compared to Group 2, as well as to Group 3. There is a significantly larger number of workers with radiographic changes suggesting asbestosis, in whom the level of IgG is above normal.

REFERENCES

1. El-Sewefy, A. Z., Fasan, F.: Immunoelectrophoretic pattern changes in asbestosis, *Ann. Occup. Hyg.* 14:25-29 (1971)
2. Lange, A., et. al.: Autoantibodies and Serum Immunoglobulin Levels in Asbestos Workers. *Int. Arch. Arbeitsmed.* 32:313-321 (1974)
3. Parazzi, E., et al.: Studies on "in vitro" cytotoxicity of asbestos dust, *Med. Lav.* 59:561-566 (1968)
4. Pernis, B.: Silicosis, In: A.P. Miescher/Eds., *Textbook of immunopathology*, Sect. II: Clinical immunopathology, Vol. I. pp. 293-301. Grune and Stratton, New York-London (1968).
5. Turner-Warwick, M. Doniach D.: Auto-antibody studies in interstitial pulmonary fibrosis. *Brit. Med. J.* 1:886-893 (1965).

CHANGES IN LUNG FUNCTION IN COAL-MINERS WITH AND WITHOUT CWP

S. KOVÁCS • F. Sárdi

Institute of Pathophysiology, Univ. Med. School, Pécs, Hungary

ABSTRACT

Spirometry, body plethysmography, analysis of flow-volume curves and single-breath CO diffusing capacity measurements were made on 620 coalminers working in the same colliery. The coalminers were divided into groups according to X-ray categories of CWP, age, and underground working time. Smokers and nonsmokers were also compared.

All parameters of lung function were significantly different from the corresponding control values even in the non-pneumoconiotic group (439 miners). The greatest decrease found in the maximal expiratory flow at 25% of vital capacity (MEF-25%) and in the maximal midexpiratory flow (MMEF).

Differences from the corresponding control values in all measured parameters increased with age and underground working time. However, in the youngest age group (under 30 years) with a relatively short working time (under 5 years) only MEF-25% and MMEF values changed significantly indicating an early damage in the function of the peripheral airways.

Changes in lung function were more marked in pneumoconiotic miners. Though significant differences from predicted values were found in miners who never smoked, the changes in the lung function were found, however, markedly greater in the smokers.

No Paper provided.

EFFECT OF ALVEOLAR LINING MATERIAL ON PARTICLE BINDING AND PHAGOCYTOSIS

M. F. KHAN* • J. E. Gallagher • A. R. Brody

Laboratory of Pulmonary Pathobiology, NIEHS, Research Triangle Park, North Carolina, USA

*Present address: Industrial Toxicology Research Centre, Post Box No. 80, Lucknow 226001, India

ABSTRACT

Cellular mechanisms which mediate the particle-induced pulmonary fibrosis are not fully known. Alveolar macrophages actively phagocytize and clear the particulates from the alveolar surfaces. However, before macrophages encounter inhaled particles, the particles come in contact with the macromolecules of alveolar lining layer (ALL) which could alter their surface properties and consequent interactions with pulmonary cells. Since little is known about the role, the ALL components may have in interactions between inhaled particles and macrophages, we have initiated studies to understand this complex issue. Rat lung lavage was concentrated and centrifuged at $178000 \times g$ for 1 hour to separate protein and lipid-rich fractions. The binding of particles (+vely charged carbonyl iron spheres and -vely charged glass beads; 4.5 mg/ml) to the macrophage monolayers (2×10^5 cells) was studied scanning electron microscopy either by treating the cells with lavage fractions or by treating the particles with lavage components. When the cells were pre-treated with normal lavage (protein conc. 50 $\mu\text{g/ml}$), concentrated lavage (protein conc. 165 $\mu\text{g/ml}$), protein fraction (125 $\mu\text{g/ml}$) and lipid-rich fraction (phospholipid conc. 305 $\mu\text{g/ml}$), there was a significant reduction in particle binding. The concentrated lavage and protein fractions caused maximum inhibition which was concentration dependent. The effect was reversed by rinsing the cells with PBS prior to adding the particles. Pretreating the spheres with lavage fractions also caused significant reduction in particle binding which was not reversible. These fractions also blocked the phagocytosis of a significant number of particles. Thus, it is the interaction between particles and ALL components rather than an interaction between macrophages and the components which is responsible for decreased binding. The *in vitro* studies should be useful in understanding complex events may be occurring between particles and ALL on alveolar surfaces.

No Paper provided.

TOXICITY RISKS FROM BACTERIAL ENDOTOXIN INHALATION

ROBERT BURRELL, Ph.D. • S-H. Ye, M.D.

Department of Microbiology and Immunology, West Virginia University
Health Sciences Center, Morgantown WV, USA and
Institute of Radiation Medicine, Shanghai Medical University, China

INTRODUCTION

The effect of bacterial endotoxin on the lung is an important factor in shock following sepsis and adult respiratory distress syndrome (ARDS), wherein endotoxin or mediators stimulated by this ubiquitous substance reach the lung via peripheral circulation. Endotoxin is also important in causing pathophysiology to the lung when inhaled and thus represents a potential risk to workers subjected to certain types of environmental exposure.

It is known that inhalation of environmentally realistic concentrations of endotoxin causes a number of reactions, depending on dose, within 4–6 hrs. Among these are fever,¹ neutropenia followed by leukocytosis,² a decline in FEV₁,¹ endotoxin tolerance on subsequent challenge,^{3,4} increased production of leukocytic enzymes in bronchial alveolar lavages,⁵ significant decreases in lung volume due to changes in volume of the distal air space,⁴ increased volume densities of neutrophils and platelets in pulmonary septal capillaries,⁴ significant changes in pulmonary capillary endothelium, e.g., increased density of pinocytotic vesicles, cytoplasmic blebbing, and focal disruption,⁴ increased pulmonary capillary permeability,⁶ and possible septal infiltration of fluids and inflammatory cells.⁶

Also, there is evidence that prior insults to the lung render the lung subsequently more vulnerable to exposure to endotoxin. Such predisposing factors could be surgical manipulation, intubation, anesthesia,⁷ hypoxia,^{8,9} burns,¹⁰ other effects induced by the endotoxin,¹¹ or even recent prior experience with endotoxin.³ To supplement the knowledge of the known risks of workers exposed to inhalation of endotoxin, the purpose of this study is to determine if endotoxin inhalation may predispose workers to further pulmonary injury in an experimental model of ARDS.

MATERIALS AND METHODS

Male hamsters, an experimental animal free of common pulmonary epizootics, were used throughout. Randomly divided groups were administered either standardized aerosols of purified *Enterobacter agglomerans* lipopolysaccharide as the source of endotoxin (5 hrs at 4 µg/m³) or saline suspensions of *E. agglomerans* cells adjusted to an O.D.₅₄₀ of 0.400 for 1 hr.⁷ Control animals were given no aerosol. Timing was commenced at the cessation of the aerosol. At appropriate intervals, the animals were anesthetized with barbiturates and subjected to bronchoalveolar

lavage (BAL). Cells from lavages were tested for viability by trypan blue exclusion, counted, and analyzed differentially by cytocentrifugation and Wright-Giemsa staining. All cells proved to retain viability >95%.

RESULTS

Effect of Endotoxin Inhalation on Free Lung Cells

Twenty-two hamsters were randomly divided into control, 6, 24, and 48 hr post inhalation groups and subjected to either no aerosol (control) or the standard LPS inhalation challenge. Results from the lavages taken at the designated time intervals are depicted in Figure 1 and were statistically analyzed by the two-tailed T-test for independent variables (p was set at <0.01).

Inhaled endotoxin caused a marked increase in total free lung cells recovered by lavage, reaching a maximum at 24 hrs and returning to near normal by 48 hrs. PMNs began to increase proportionately within hours, reaching a maximum at 6 hrs whereas alveolar macrophages decreased proportionately and recovered slowly after that time. Although the total cell count had returned to near normal levels 48 hrs after aerosol exposure, the ratios of neutrophils and macrophages had not yet completely returned to normal values. Lymphocytes on the whole were unaffected except for the slight (not significant) rise at 24 hrs.

Comparison of Inhaled Endotoxin vs. Inhaled Whole Bacteria

Next, pulmonary reactions were compared from animals challenged with aerosolized saline suspensions of endotoxin or whole *E. agglomerans* bacteria for 1 hr. Lavages were made at only one time point, at 6 hrs, the time for development of maximum microlesions. The results, statistically analyzed as previously, appear in Figure 2.

Inhalation of bacteria induced a significantly greater leukocyte infiltration into the lung. Most of this infiltrate consisted of alveolar macrophages and neutrophils. The ratio of alveolar macrophages was greater in the animals receiving whole cells, whereas the ratio of neutrophils was higher in the endotoxin-exposed animals.

Effect of Combined Inhalation and Intravascular Contact with Whole Bacteria

Hamsters were given a standard aerosol of whole

ENDOTOXIN INHALATION

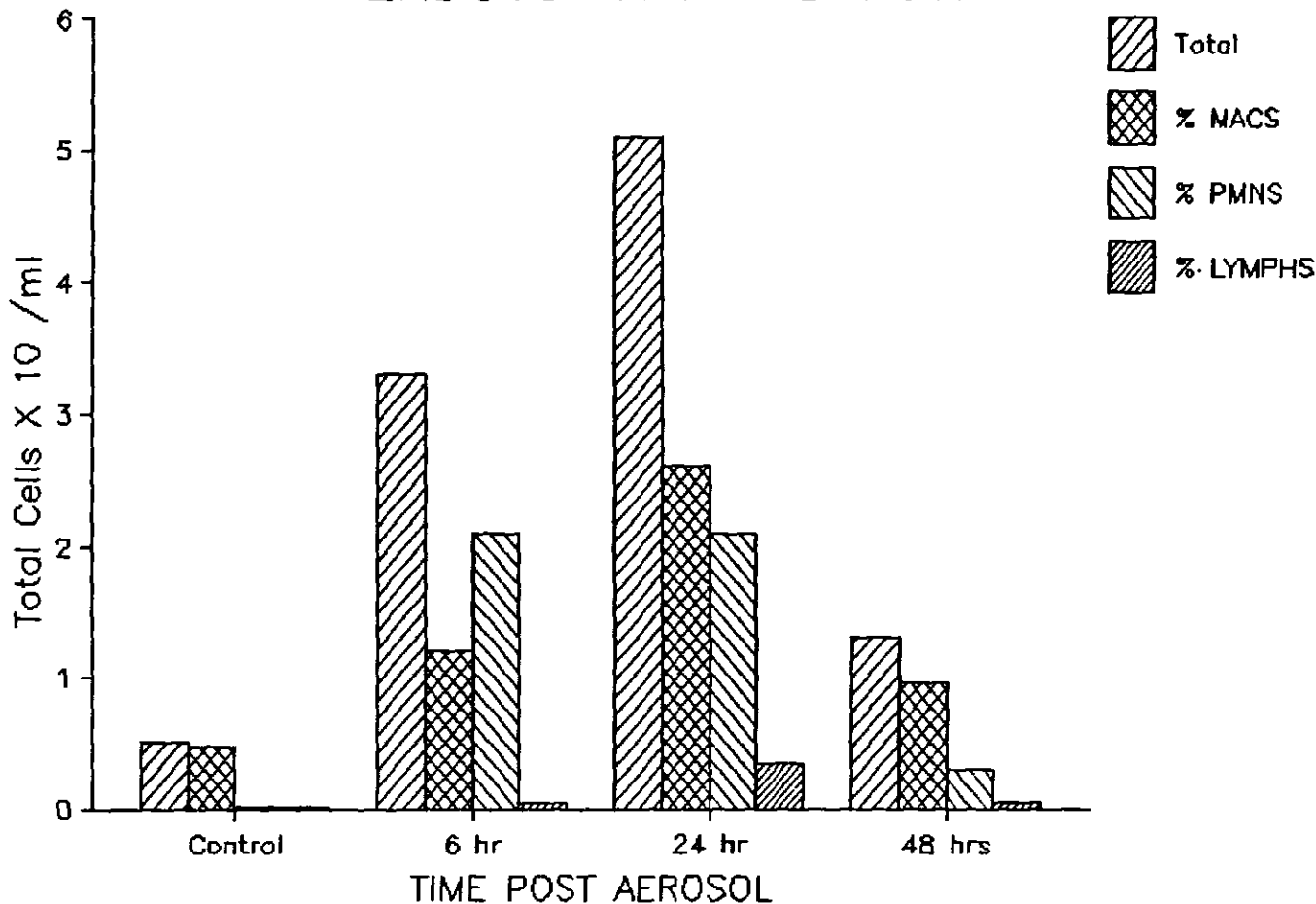

Figure 1. Free lung cell analysis of hamster bronchoalveolar lavages with time after endotoxin inhalation.

E. agglomerans cells for 30 min and allowed to rest for 6 hrs to maximally develop pulmonary microlesions.⁴ One hour before this peak, the animals were anesthetized and intravenously injected with 0.2 ml of the same suspension used for aerosolization. After 1 hr, the animals were killed and BAL made for free lung cell analyses. Since anesthesia⁷ has been reported as one of the operative procedures that may predispose the ARDS condition and possibly enhances prior endotoxin exposure, controls included animals subjected to anesthesia with no intravascular injection. The data are presented in Table I. Two types of comparisons were statistically analyzed: one, where all treatment groups were compared with unexposed (normal) controls and the other where the complete regimen (aerosol, anesthesia, and I.V. bacteria) was compared with each of the other groups. The results giving the level of significance are shown in Table II.

Exposure to the complete regimen was characterized by a marked increase in erythrocytes and a relative decrease in the proportion of alveolar macrophages while the neutrophils proportionately increased. This could indicate possible pulmonary hemorrhage. The anesthetic, if anything lessened the effects of the bacterial aerosol, and seemed to contribute little on its own to the free lung cell reaction. The com-

combined anesthetic and I.V. bacteria had no significant effect.

DISCUSSION

Inhalation of either purified bacterial endotoxin or whole cells induces significant increases in total pulmonary leukocytes, due mostly to increases in alveolar macrophages and neutrophils. Inhalation of bacteria produced more pronounced reactions emphasizing a greater neutrophil response, whereas the reaction to inhaled endotoxin was lower and predominantly due to alveolar macrophages.

Since these PMNs are not seen in morphometric analysis of the alveoli, infiltration of the higher airways must be considered important.

If the lung were to receive a second insult during the time when the inflammatory response to the initial stimulus was highest, the lung might be in a more vulnerable position. When inhalation of Gram—bacteria was followed by an I.V. injection of similar cells, a large increase in erythrocytes, suggesting pulmonary hemorrhage accompanied by a relative decrease in the proportion of alveolar macrophages and a proportionate increase in neutrophils. Such changes were not

Inhalation Comparison of Endotoxin vs. Whole Bacteria

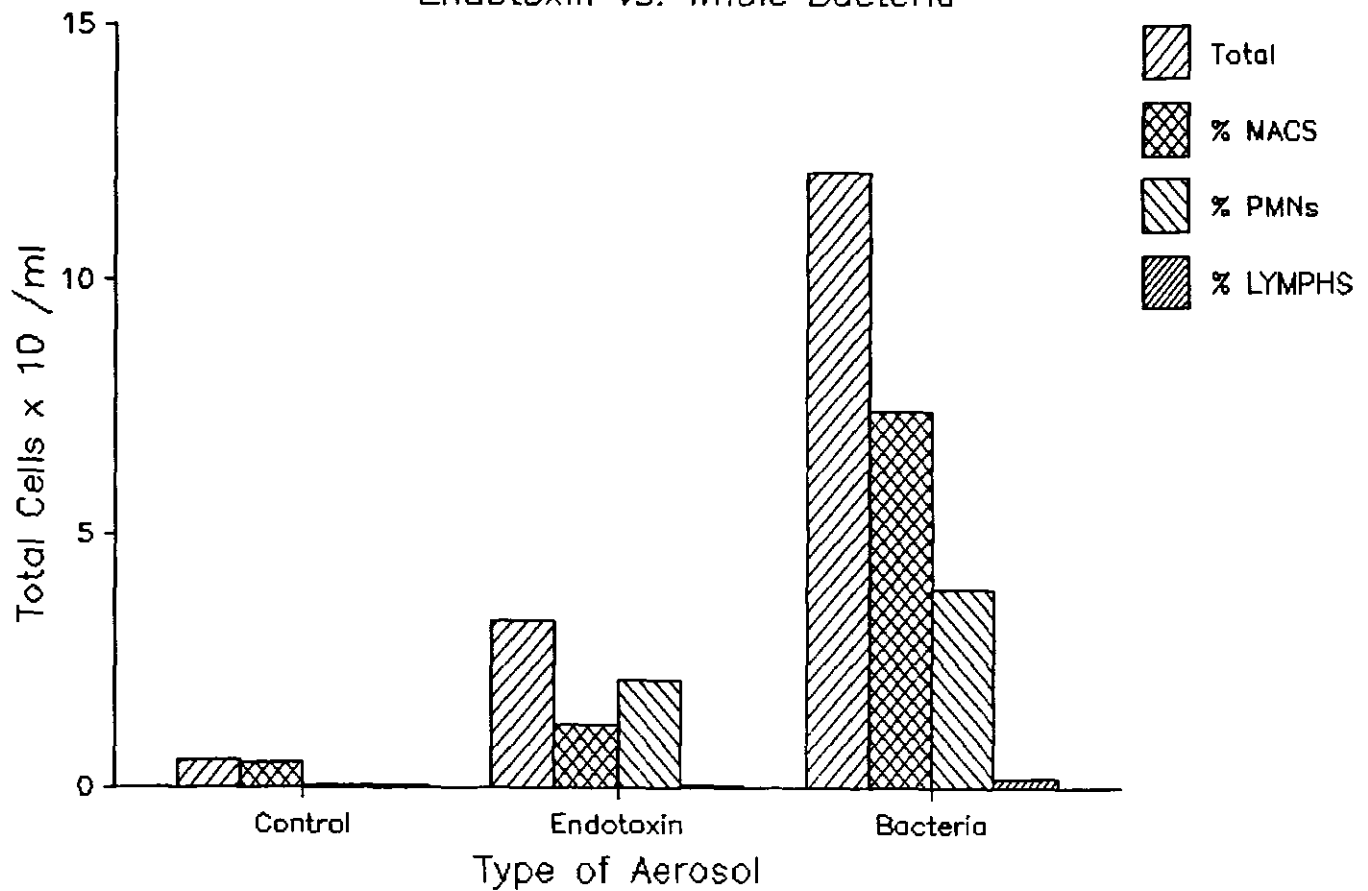

Figure 2. Comparison of free lung cell lavages taken 6 hrs after either inhalation to endotoxin or whole Gram negative bacteria.

due to intravenous bacteria alone, but were only significant when the bacteria were inhaled.

Taken together with the other known inflammatory effects

of inhaled or endotoxin-containing bacteria, such inhalation in an occupational setting constitutes an increasingly recognized risk for workers.

Table I
Effect of Combined Pulmonary and Intravascular Exposure on Free Lung Cells

Type	n	Cells X 10 ⁵ /ml			% Cell Content			
		Total	WBC	RBC	RBC	MO	PMN	Ly
Normal	10	0.6±0.1	0.5±0.1	0.1±0.1	7.7±9.3	87.0±9.6	4.5±4.3	2.6±1.2
Complete ¹	5	8.5±3.5	1.8±0.6	6.7±3.5	31.4±9.6	36.0±9.9	31.7±8.1	0.3±0.3
Bacteria + anesesthesia	8	6.8±1.0	2.5±1.1	3.2±1.7‡	2.6±0.8‡	92.0±2.6‡	3.5±2.3	2.0±1.2
Bacteria aerosol only	11	12.1±6.2	5.1±4.0	7.9±3.3*	2.3±1.6*	61.2±9.8	32.9±8.9	1.2±1.1
Anesthes + IV Bacteria	5	0.7±0.2	0.5±0.1	0.3±0.2	8.8±6.7	84.5±5.4	2.9±1.8	3.7±1.8

¹ Complete = bacterial aerosol, anesthesia, and I.V. bacteria

* n = 6

‡ n = 4

Table II
Statistical Analyses of Bronchopulmonary Lavages from Table II

Parameter	vs	Cells X 10 ⁵			% Cell Content			
		Total	WBC	RBC	RBC	MO	PMN	Ly
Complete	Normal	.007	.009	.014	.0005	<.0001	<.0001	.0001
Bact aer + anes	Normal	<.0001	.001	.04	N.S.	N.S.	N.S.	N.S.
Bact aer only	Normal	.0001	.003	.002	N.S.	<.0001	<.0001	.01
Anesthes + IV Bacteria	Normal	N.S.	N.S.	N.S.	N.S.	N.S.	N.S.	N.S.
Bact aer + anes	Complete	N.S.	N.S.	N.S.	.003	.002	.002	.006
Bact aer only	Complete	N.S.	.04	N.S.	.003	.0003	N.S.	.04
Anesthes + IV Bacteria	Complete	.008	.01	.015	.003	<.0001	.002	.02
Bac aer only	Bact aer + Anes	.03	N.S.	.03	N.S.	<.0001	<.0001	.003

REFERENCES

1. Pernis, B., Vigliani, E.C., Cavagna, C., Finulli, M. The Role of Bacterial Endotoxins in Occupational Disease Caused by Inhaling Dusts. *Brit. J. Ind. Med.* 18:120-129 (1961).
2. Birch, K. The Role of Endotoxin Tolerance in Byssinosis. Thesis, West Virginia University, Morgantown WV (1983).
3. DeMaria, T.F., Burrell, R. Effects of Inhaled Endotoxin-containing Bacteria. *Env. Res.* 23:87-97 (1980).
4. Lantz, R.C., Birch, K., Hinton, D.E., Burrell, R. Morphometric Changes in the Lung Induced by Inhaled Bacterial Endotoxin. *Exp. Mol. Path.* 43:305-320 (1985).
5. Burrell, R., Rylander, R. Further Studies on Inhaled Endotoxin-Containing Bacteria. *Environ. Res.* 27:325-336 (1982).
6. Burrell, R., Lantz, R.C., Hinton, D.E. Mediators of Pulmonary Injury Induced by Inhalation of Bacterial Endotoxin. *Amer. Rev. Resp. Dis.* 137:100-105 (1988).
7. Webster, R.O., Larsen, G.L., Mitchell, B.C., Goins, A.J., Henson, P.M. Absence of Inflammatory Lung Injury in Rabbits Challenged Intravascularly with Complement-derived Chemotactic Factors. *Amer. Rev. Resp. Dis.* 125:335-340 (1982).
8. Henson, P.M., Larsen, G.L., Webster, R.O., Mitchell, B.C., Goins, A.J., Henson, J.E. Pulmonary Microvascular Alterations and Injury Induced by Complement Fragments: Synergistic Effect of Complement Activation, Neutrophil Sequestration, and Prostaglandins. *Ann. N.Y. Acad. Sci.* 384:287-300 (1982).
9. Larsen GL, Webster RO, Worthen GS, Gumbay RS, Henson, PM. Additive Effect of Intravascular Complement-Activation and Brief Episodes of Hypoxia in Producing Increased Permeability in the Rabbit Lung. *J. Clin. Invest.* 75:902-910 (1985).
10. Nerlich, M., Flynn, J., Demling, R.H. Effect of Thermal Injury on Endotoxin-Induced Lung Injury. *Surg.* 93:289-296 (1983).
11. Meyrick, B.O., Brigham, K.L. The Effect of a Single Infusion of Zymosan-Activated Plasma on the Pulmonary Microcirculation of Sheep. *Amer. J. Path.* 114:32-45 (1984).

DESCRIPTION OF MEDICAL SERVICES RENDERED AT THE CHRISOTILA ASBESTOS MINE, WITH 1100 EMPLOYEES, IN THE STATE OF GOIÁS, BRAZIL

A. S. NUNES • F. S. Macedo • H. L. Silva

“S. A. Mineração de Amianto”, Boiás, Brazil

ABSTRACT

In order to have the conscientization, control and prevention of professional diseases, a Labour Medicine Service Center was created, with the following staff: 2 Labour Medicine physicians, 1 nurse, 1 Labour Medicine nurse attendant, 3 nurse attendants, 1 RX technician, 1 dentist, 1 secretary and 1 receptionist; and with the following equipment: a 500 mA RX equipment, an automatic processing machine, an audiometer, a spirometer and a complete dental office, all within a 250 m² area.

The specialized care for employees and their dependents (7000 persons) is done at the Company's hospital, which has 30 beds and a 60 people staff, including 8 physicians, 2 nurses, 3 dentists, amongst others.

The Labour Medicine program offers monthly conferences on the risks of ASBESTOS. The medical examinations are made upon admission, annually and upon transfers, promotions or dismissals of employees, as well as in dismissed or retired employees.

Taking into consideration the geographical localization of the Mine, 500 Km from a large populational center, the conscientization for safety and social stability is done to the workers in a multi-disciplinary work, jointly with the Social Security (Governmental entity), Technical Engineering, Labour Safety and Social Service Departments.

No Paper provided.

HIGH-RESOLUTION COMPUTED TOMOGRAPHY OF PNEUMOCONIOSIS

MASAMITSU KIDO,* M.D., Dr. Med. Sci. • Akira Kajiki,* M.D., Dr. Med. Sci.

• Hiroshi Yamazaki,* M.D. • Hajime Nakata,† M.D., Dr. Med. Sci.

• Kanji Egashira,† M.D.

*Pulmonary Division, University of Occupational and Environmental Health, JAPAN

†Department of Radiology, University of Occupational and Environmental Health

JAPAN 1-1, Iseigaoka, Yahatanishiku, Kitakyushu, 807 JAPAN

INTRODUCTION

The usefulness of high-resolution computed tomography (HRCT) was evaluated in 37 cases of pneumoconiosis and diagnostic accuracy was compared with those of conventional chest radiography concerning profusion, shape and size according to the ILO (1980) classification of radiographs of pneumoconiosis.

MATERIALS AND METHODS

37 patients of pneumoconiosis were all men with 39 to 86 years of age (mean 60.9 ± 9.6). Except for 2 cases, they had history of cigarette smoking, and their smoking indices were 0 to 1980, with mean 655.8 ± 398.0 .

They had histories of occupational exposure to inorganic dusts in 17 of coalminers, 4 of tunnel drivers, 4 of coal and tunnel workers, 2 of welders and 2 had history of exposure to asbestos. Eight patients had history of exposure to miscellaneous dusts such as iron ore, zinc ore, silica brick, oven construction and their combination. Their radiographic findings were classified according to the ILO classification (1980).

The CT examination consisted of a series of high resolution 2mm thick sections scanned with a Siemens somatom II. A Siemens high resolution algorithm stressing the region of high spatial frequency with zooming model was used. The scanning was performed in 10 seconds, at 125kVp, 460mAs. The pixel size was 0.5mm with a magnification factor of 4.0. Six sections were scanned routinely from the level of the sternal notch caudad at 3cm intervals, grossly imaging the upper, middle, and lower lung fields (Figure 1). All scans were made in suspended moderate inspiration. No intravenous contrast materials was used. All images were observed and photographed with the window of 2024 Hounsfield units (HU) and the level of -600 HU, and additional settings were also used as needed.

Nodular and irregular opacities were graded according to the shape and size and profusion. Emphysema was evaluated separately according to their distribution (subpleural or parenchymal) and avascular area was graded to 4 classes as 1) (0-25%), 2) (26-50%), 3) (51-75%), 4) (76-100%) respectively. Each conventional radiogram and CT was evaluated by 3 radiologists and 2 pulmonary specialists independently.

Dyspnea was graded to 1-5 according to Hugh-Jones criteria. Pulmonary function tests were performed using SRL M 100B, and FRC was measured by N₂ washout method and DL_{CO} was measured by breath holding method (Forster). Arterial blood gas was obtained under air breathing by brachial artery puncture and analyzed using automatic blood gas analyzer IL813.

RESULTS

37 patients in the study were classified into 10 of category 1, 13 of category 2, 6 of category 3, and 8 of category 4 by plain chest X-P (Table I).

17 cases of coal workers pneumoconiosis were classified into 3 of category 1, 7 of category 2, 2 of category 3 and 5 of category 4. HRCT examination revealed marked parenchymal (central) emphysema from 50 to 100% of our criteria and nodular opacities was so attenuated that they were assessed as 0/1 p. All three cases showed marked obstructive ventilatory disturbance with 42 to 59% of FEV_{1.0}%. As compared with category 1 of coal workers pneumoconiosis, 7 of category 2 revealed milder emphysema score of 25% except for one case of 75%. Profusion of nodular opacities in HRCT are generally lower than conventional chest X-P in this group except for two cases which are complicated by tuberculosis. Among category 3, profusion of small opacities by HRCT was also lower than that of conventional X-P. Among category 4, evaluation of small opacities were very difficult because of destruction of intra-thoracic structure and emphysema.

3 of 4 tunnel drivers revealed dense nodular opacities higher than category 2 in conventional X-P and they are all graded as category 3 by HRCT. Three of four tunnel and coal workers also revealed marked nodular opacities by X-P and CT.

As a whole, except for category 4 and asbestos cases, 23 of 31 cases showed lower profusion score in CT than in conventional X-P. This may reflect the effect of summation in postero-anterior projection of plain X-P compared with the horizontal thin slice in CT. Subpleural curvilinear opacities were observed in three cases of coal workers pneumoconiosis and one case of asbestosis.

Two cases of asbestosis showed marked irregular opacities in the middle and lower lung field in plain X-P. One of them

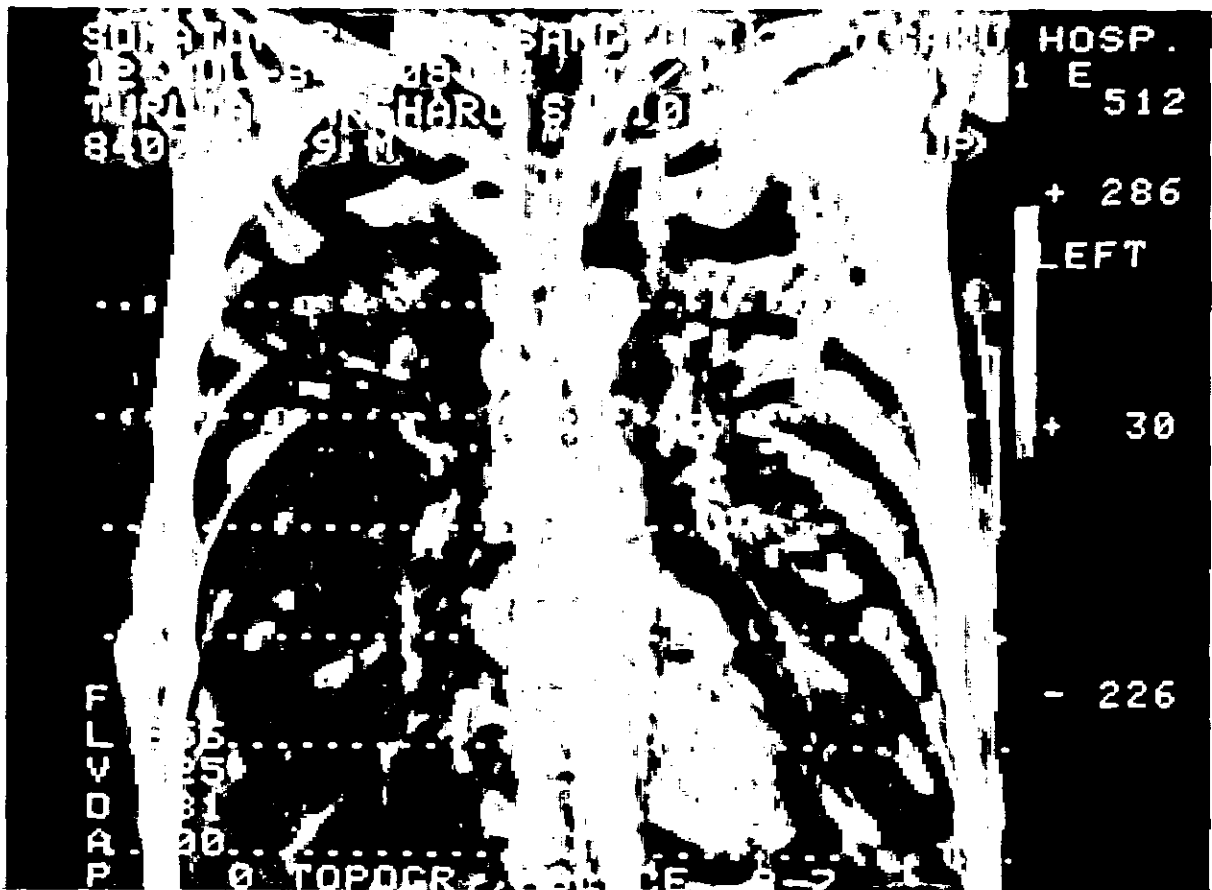

Figure 1. Tomogram showing the levels of the six routine sections.

also revealed calcified pleural plaques along the crura of the bilateral diaphragm. CT revealed more clearly the calcified plaques along the thoracic wall with varying thickness. Another case showed intense irregular opacities with honey comb appearance. The CT scan demonstrated marked interstitial changes with subpleural curvilinear opacities which could not be demonstrated by plain X-P. In the upper lung field, CT also revealed marked emphysematous changes which may explain the marked obstructive ventilatory disturbance (VC 116% of predicted, FEV_{1.0%} 55%). Dyspnea score was 2.5 ± 1.0. No clear correlation was found between the radiographic category and dyspnea score.

Studies on pulmonary function were VC 95.7 ± 17.9 percent (mean SD) of predicted value, FEV_{1.0}/FVC 64.2 ± 15.6 percent, flow at 75% FVC (V25) divided by height (meter) 0.38 ± 0.24 L/sec/m, RV/TLC 37.4 ± 10.3, %DL_{CO} 106.2 ± 27.5%, PaO₂ ± 78.7, 6.8 torr, A -aDO₂ 24.0 ± 7.4 torr (Table I).

No clear correlation was found between conventional radiographic findings nor HR-CT findings and pulmonary function parameters except emphysema score by CT and FEV_{1.0%} which showed mild inverse relationship.

Nodular opacities, interstitial fibrosis, bullae and emphysema were more clearly and specifically demonstrated on HR-CT scans than on conventional chest radiographs in most patients.

Radiologic-pathologic correlation was performed on the specimens of transbronchial lung biopsy in 4 patients. One case was illustrated in Figure 2. This 54-year-old retired silica brick factory worker showed combined restrictive and obstructive ventilatory disturbance with VC of 57%, FEV_{1.0%} of 42%, flow at 75% FVC of 0.13L/sec/m. Plain X-P (Figure 2a) was categorized as PR1p. HRCT also revealed dense nodular opacities in upper and middle level of slice (Figure 2b). Subpleural thickening of interlobular septum was also observed. Specimen of transbronchial biopsy revealed well defined pneumoconiotic nodules and mild thickening of alveolar septum (Figure 2c). Small opacities in HRCT may well reflect these small pneumoconiotic nodules seen in TBLB.

Figure 3a shows plain X-P of 88-year-old retired coal miner with an occupational history of 37 years. His autopsied lungs were fixed, dried and, scanned by HRCT and compared with radiograph by soft X-ray or macroscopic findings (Figure 3). Excellent spatial resolution of HRCT was clearly demonstrated from their comparison.

DISCUSSION

HRCT examination of the lung using an extended scale and three-to-four fold magnification imaging format presented the most recent improvement in CT. It has excellent spatial resolution in high-contrast regions which have been expected

Table I
Age, Smoking Index, Duration of Occupational Exposure, RRCT, and
Pulmonary Function Parameters According to Radiographic Categories (mean \pm SD)

X-P category	No	Age	Smoking Index	Duration of Expo. (year)	Dyspnea	CT			TVC (%)	RV/TLC (%)	FEV ₁ %Z (%)	V ₁ /H ₁ (L/sec/m)	RV/VA (%)	HCO/VA	PaO ₂ (torr)	A-aDO ₂ (torr)
						Nodular Profusion	Subpl. Emphy.	Central Emphy.								
1	10	58.5 \pm 9.3	805.0 \pm 350.7	27.2 \pm 8.6	2.4 \pm 1.2	0.3	12.5	37.5	93.4	42.5	59.4	0.33	106.8	4.74	80.1	21.2
						\pm 0.5	\pm 24.3	\pm 33.8	\pm 17.5	\pm 13.2	\pm 19.8	\pm 0.29	\pm 19.5	\pm 1.15	\pm 6.2	\pm 6.2
2	13	62.0 \pm 8.0	654.2 \pm 351.3	22.2 \pm 8.3	2.0 \pm 0.9	1.3	20.5	32.7	97.6	35.0	65.3	0.30	106.3	4.91	79.0	24.4
						\pm 1.3	\pm 27.0	\pm 27.7	\pm 13.2	\pm 6.5	\pm 9.9	\pm 0.12	\pm 25.7	\pm 1.29	\pm 5.6	\pm 7.9
3	6	58.8 \pm 9.7	615.0 \pm 145.8	21.0 \pm 12.9	2.8 \pm 0.8	1.2	45.0	55.0	96.7	33.9	76.7	0.57	91.3	4.21	74.5	28.2
						\pm 1.2	\pm 27.4	\pm 32.6	\pm 28.0	\pm 9.9	\pm 6.7	\pm 0.21	\pm 41.2	\pm 0.79	\pm 7.2	\pm 10.3
4	8	64.0 \pm 12.8	417.5 \pm 238.0	24.8 \pm 7.6	3.4 \pm 0.9	1.7	12.5	20.8	92.4	35.8	60.8	0.40	112.4	5.05	79.5	23.5
						\pm 1.3	\pm 20.9	\pm 10.2	\pm 19.6	\pm 11.3	\pm 17.9	\pm 0.33	\pm 30.1	\pm 0.96	\pm 9.1	\pm 7.1
Total	37	60.9 \pm 9.6	655.8 \pm 388.0	23.5 \pm 8.9	2.5 \pm 1.0	1.1	22.4	35.3	95.7	37.4	64.2	0.38	101.3	4.80	78.7	24.0
						\pm 1.2	\pm 27.0	\pm 28.9	\pm 17.9	\pm 10.4	\pm 15.6	\pm 0.24	\pm 27.5	\pm 1.00	\pm 6.8	\pm 7.4

to give the advantages in evaluating interstitial diseases such as pneumoconiosis. Several investigators have already reported the value of HRCT in evaluating pneumoconiosis.

We compared HRCT with conventional chest radiograph and pulmonary function studies.

Contrary to our expectation there are substantial discrepancies between radiological and CT evaluation. Concerning nodular opacities, HRCT showed good spatial resolution but lower profusion score than conventional chest radiographs. This may reflect the effect of summation in postero-anterior projection of plain X-P compared with the horizontal thin slice in CT. Attenuation of nodular opacities by emphysema also may contribute to this emphysematous cases because it is speculated that progress of emphysema may attenuate the nodular opacities.

Interstitial fibrosis, bullae, and emphysema were more clearly and specifically demonstrated on CT scan than conventional chest radiographs in most patients. The subpleural distributions of bullae were particularly well demonstrated in CT which may not be reflected in pulmonary function studies.

HRCT is useful for performing detailed morphological analyses of abnormalities of the peripheral portions of the

lung, but no clear correlation was found between HRCT findings and pulmonary function parameters.

REFERENCES

1. Todo, G., Ito, H., Nakano, Y., et al.: High-resolution CT(HR-CT) for the evaluation of pulmonary peripheral disorders. *Rinshohosyasen*. 27:1319-1326 (1982) (In Japanese).
2. Fiore, D., Biondetti, P.R., Sartori, F., Calabro, F.: The role of computed tomography in the evaluation of bullous lung disease. *J. Comput. Assist. Tomogr.* 6:105-108 (1982).
3. Kneel, L.: Computed tomography of interstitial pulmonary disease. *J. Comput. Tomogr.* 6:181-199(1982).
4. Muhm, J.R., Brown, L.R., Crowe, J.K. et al.: Comparison of whole lung tomography and computed tomography for detecting pulmonary nodules. *Am. J. Roentgenol.* 131:981-984(1978).
5. Eakata, H., Kimoto, T., Nakayama, T. et al.: Diffuse peripheral lung disease: Evaluation by high-resolution computed tomography. *Radiology* 157:181-185(1985).
6. Examination of the fine interstitial changes of pneumoconiosis with high resolution computed tomography (HR-CT). *J. UOEH* 8 (suppl):363-367 (1986).
7. Aberle, D.R., Gamusu, G., Ray, C.S. et al.: Asbestos-related pleural and parenchymal fibrosis. Detecton with high-resolution CT. *Radiology* 166:729-734 (1988).
8. Begin, R., Bergeron, D., Samson, L. et al.: CT assessment of silicosis in exposed workers. *Am. J. Roentgenol.* 148:509-514 (1987).
9. Bergin, C.J., Muller, N.L., Vedal, S. et al.: CT in silicosis: Correlation with plain films and pulmonary function tests. *Am. J. Roentgenol.* 146:477-488 (1986).



Figure 2a. 54-year-old man with a history of silica-brick factory worker for 35 years. Chest radiograph showing small round opacities.

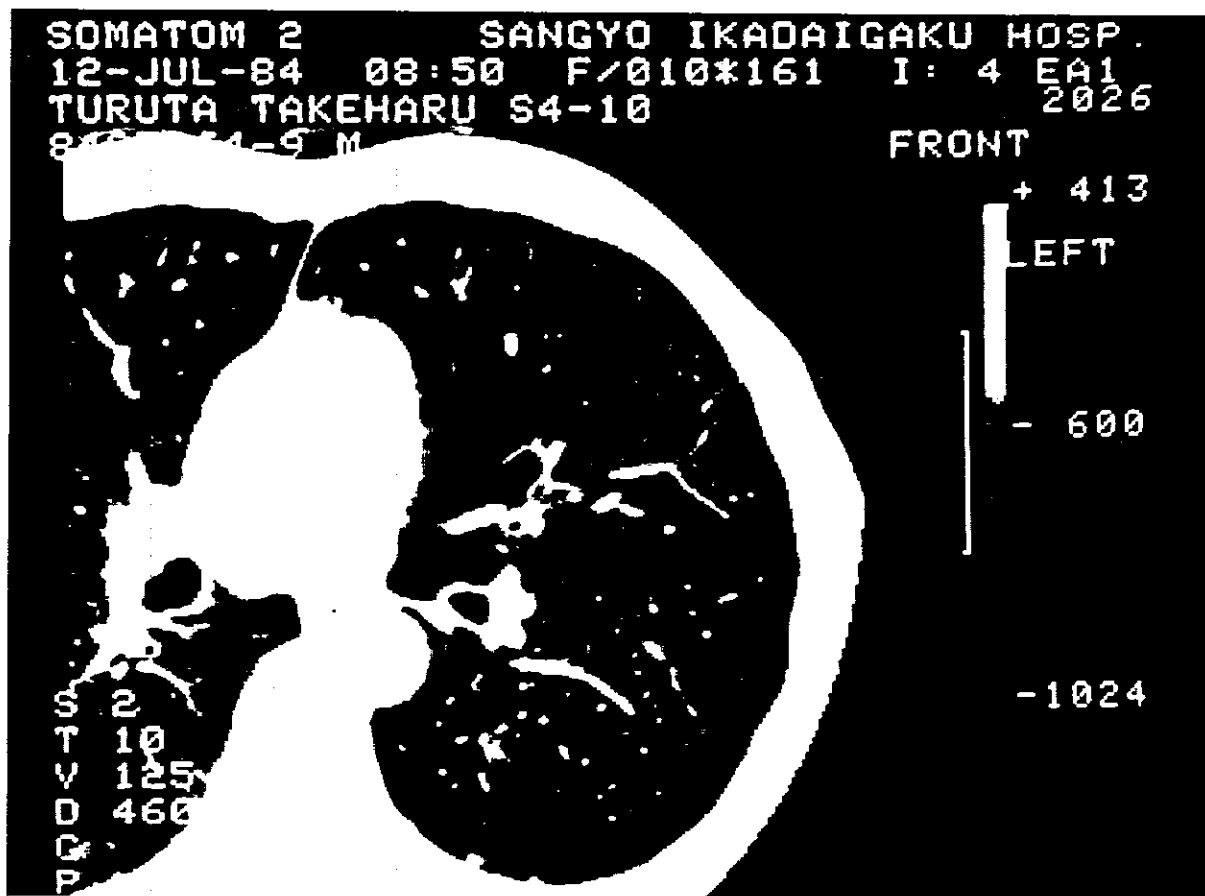

Figure 2b. HRCT. Diffuse well-defined small opacities in the middle lung fields.

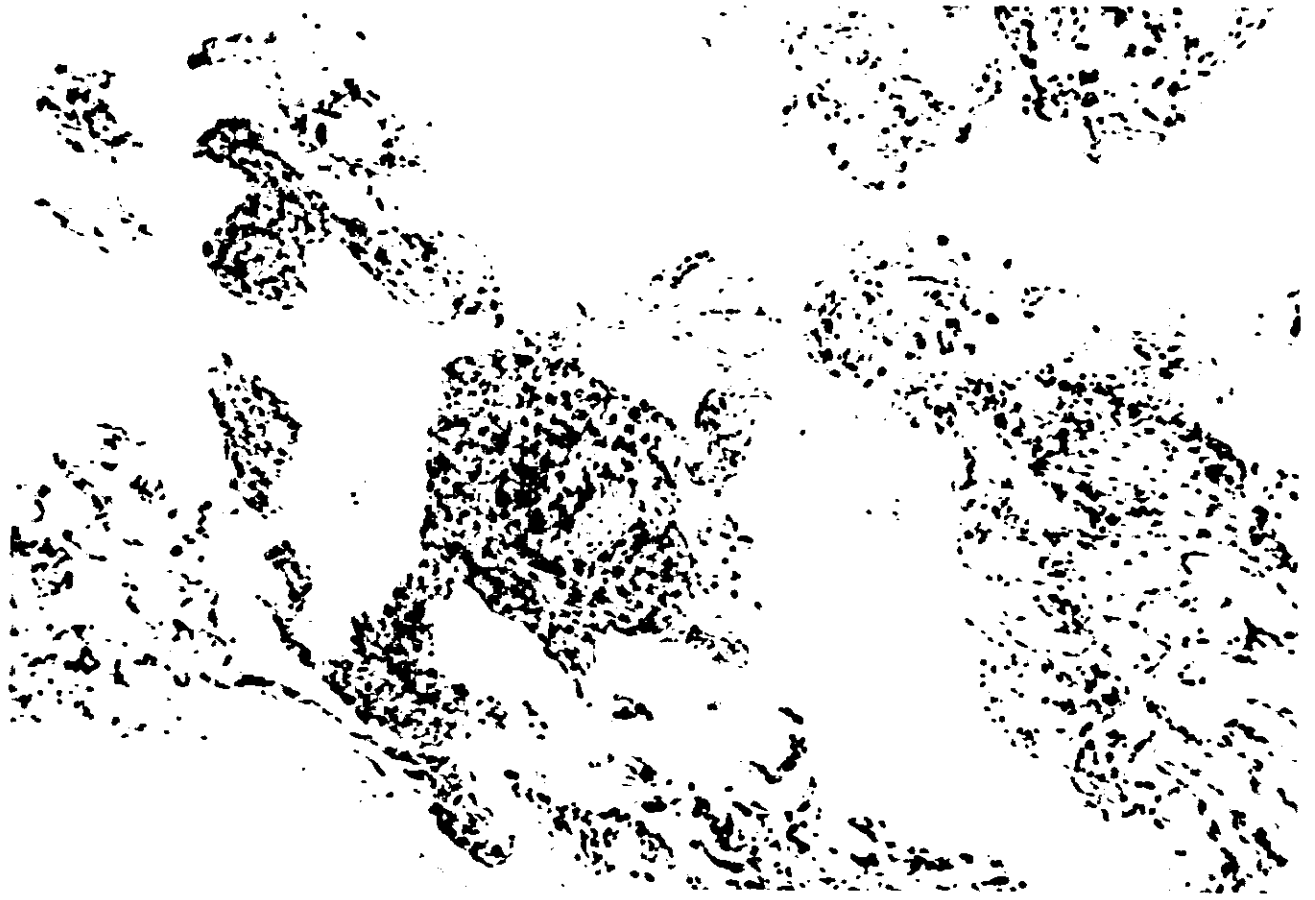

Figure 2c. Photomicrograph of transbronchial lung biopsy showing well-defined pneumoconiotic nodule. Hematoxylin and eosin stain, x40.

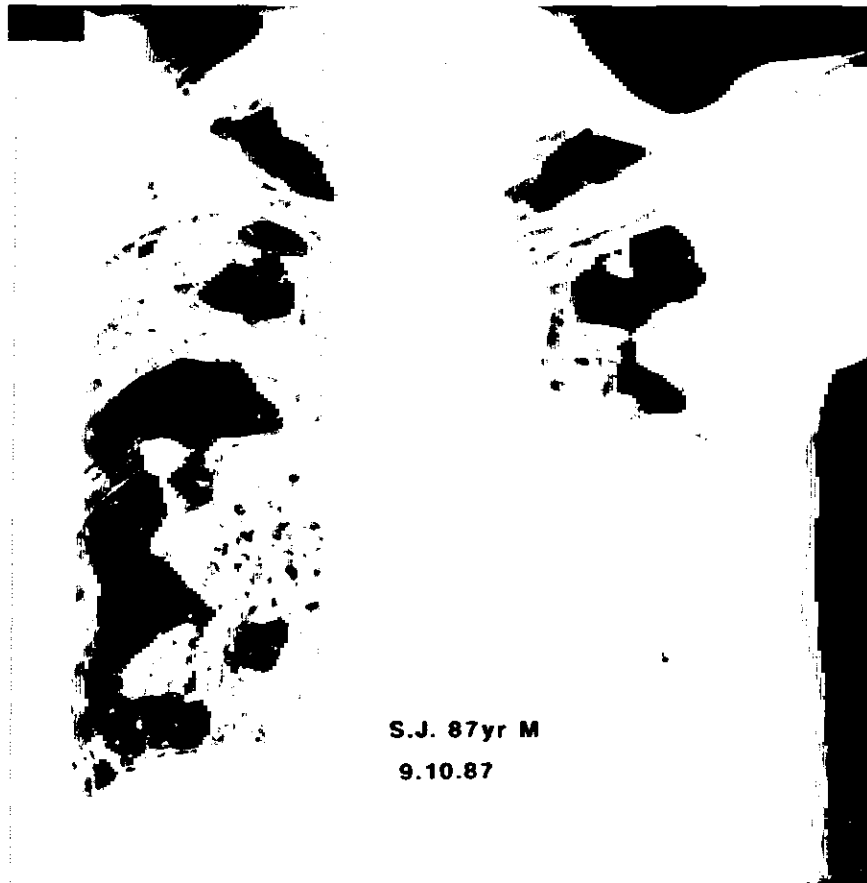

Figure 3a. 88-year-old man with a history of coal miner for 37 years.
Chest radiograph eight month prior to his death shows large opacities and fibrocalcified tuberculous change with few nodular opacities.



Figure 3b. HRCT of autopsied lung after fixation at the level of middle lung field.



Figure 3c. Post-fixation radiograph of lung in the horizontal slice at the same level as HRCT.



Figure 3d. Macroscopic view of lung at the same level.

ASBESTOS-ASSOCIATED ROUNDED ATELECTASIS IN A COHORT OF INSULATION WORKERS

ALFRED FRANZBLAU, M.D. • Irving J. Selikoff, M.D.

Division of Environmental and Occupational Medicine
Mount Sinai Medical Center, New York, NY 10029, USA

ABSTRACT

Insulation workers with more than 30 years elapsed time since entering the trade were invited to participate in a nationwide screening. Twenty-nine hundred and seven men were examined between 1981 and 1983 in 20 U.S. cities. Twelve cases of lung cancer and two cases of pleural mesothelioma, previously undiagnosed, were discovered during the survey. By 1988, twelve were dead and two alive. Thirteen cases of asbestos-associated rounded atelectasis were also found. All were alive and free of cancer after a minimum of four years follow-up. Comparison of clinical parameters (duration from onset of exposure, ILO radiographic categories, pulmonary function test results, respiratory symptoms, smoking histories, findings on clinical examination) showed no major differences between the two groups. Asbestos-associated rounded atelectasis is not rare among workers with substantial asbestos exposure and latency.

INTRODUCTION

Because of the well known increased risk of malignant disease among asbestos exposed workers, discovery of a lesion suspicious for neoplasm on the chest radiograph of an asbestos exposed individual is a cause for considerable concern.^{1,2} Rounded atelectasis (RA) is a nonmalignant consequence of exposure to asbestos which, on chest radiographs, can mimic neoplasia. Since the first report in 1966,³ asbestos associated rounded atelectasis (AARA) has been described in a number of case reports or case series.^{4,5,6,7,8,9} One report has enumerated cases of AARA within a defined community, thus permitting an estimate of incidence of this condition,⁹ though the methods and characteristics of the population differ substantially from those used in the present investigation.

We describe the prevalence of AARA within a well-defined cohort of asbestos insulation workers. Clinical parameters of cases of AARA are compared to those of cases of lung cancer and mesothelioma discovered during the same survey of workers. The cross-sectional prevalences of newly-discovered cancer and AARA were similar. No clinical features, aside from possible radiographic appearance, were capable of distinguishing AARA from cases of lung cancer or mesothelioma in this survey.

METHODS

A cohort of asbestos insulation workers in the United States and Canada was established on 1 January 1967.¹⁰ It included all 17,800 members on the roles of the insulation workers union (The International Association of Heat and Frost Insulators and Asbestos Workers (IAHFIAW), AFL-CIO, CIC) in the United States and Canada on that day.

A total of 5377 members of the cohort who were alive in 1981 and had reached 30 years from onset of work exposure were invited to appear for a comprehensive medical examination. Twenty-nine hundred and seven insulators were examined in 1981-1983, of which 2815 had greater than 30 years elapsed time since onset of exposure to asbestos. Reasons for non-participation (employment requirements, unrelated illness, family responsibilities, travel constraints, lack of interest) were ascertained and did not suggest significant selection bias. All survey participants are included in this analysis. Examinations were undertaken in Chicago, Columbus, Baltimore, Boston, Atlanta, Tampa, Seattle, Anchorage, San Francisco, Los Angeles, Denver, Omaha, St. Louis, Albuquerque, Dallas, Houston, New Orleans, New York, New Jersey, and Syracuse. The examinations included occupational, medical, and smoking history, review of symptoms, respiratory symptom questionnaires, physical examination, chest radiographs, pulmonary function tests, and laboratory tests.

Following completion of the survey in 1983, all chest radiographs were interpreted according to the 1980 International Labour Office guidelines for classification of chest radiographs for pneumoconioses.¹¹ In 1987, the radiographic interpretations of all 2907 insulation workers were reviewed. All cases in which the radiographic interpretation included comments such as "cancer," "mesothelioma," "pseudotumor," "rounded atelectasis," "nodule," "granuloma," "effusion," or suggested the presence of a nodule, effusion, or mass lesion were re-examined. In addition, all cases in which the recorded interpretation included ILO symbols suggestive of cancer ("ca"), effusion ("ef"), enlarged hilum ("hi"), or other lesions

("od") were also studied. One hundred thirty-nine cases were reviewed.

The initial review consisted of re-evaluation of the 139 chest radiographs obtained during the survey, without knowledge of patients' examination results or follow-up status. On the basis of the radiographs, patients were classified as "possible" cancer/AARA, or not cancer/AARA; the latter cases were excluded from further consideration. Previously published radiographic features of AARA were used as guidelines in the identification of AARA.⁶ Each of the remaining cases was then reviewed using all available materials, including all data obtained at the time of the survey, subsequent correspondence with patients and/or their physicians, hospital records, previous and subsequent radiographs and radiology reports, death certificates, necropsy reports, independent analysis of pathologic material,* and direct contact with patients.

It was determined that twelve cases of lung cancer and two cases of pleural mesothelioma were discovered during the survey. (There were thirteen additional cases of lung cancer identified among participants of the survey, but these cases had been known or suspected prior to the survey and are not included in the analysis.) Thirteen study participants were classified as having AARA following a thorough review of available data and determination of clinical status after at least four years follow-up. Vital status of each of the 27 cases of interest was determined in one of two ways: death certificate; direct telephone contact with the patient or the patient's spouse.

RESULTS

Two thousand nine hundred and seven men participated in the nationwide survey of insulation workers. As outlined above, 139 cases were reviewed in detail for this report. Using all available information and determination of vital status after a minimum of four years of follow-up, 13 cases of AARA and 14 cases of newly discovered cancer were identified. Twelve of the latter were lung cancer, and two were pleural mesothelioma. The prevalence of AARA among men who participated in the survey was $13/2907 = .45\%$, which is comparable to the prevalence of newly discovered chest cancers ($14/2907 = .48\%$).

Twelve deaths occurred among newly discovered lung cancer and mesothelioma patients and were confirmed via death certificate. In addition to the underlying cause listed on the death certificate, ascertainment of the cause of death was supplemented by physician notes, hospital records, autopsy reports, and independent analysis of pathologic material. All deaths occurred less than four years after each individual's survey date, and all deaths were attributed to neoplasms discovered during the survey.

The remaining 15 patients were determined to be alive at least four years after their survey examinations on the basis of direct telephone contact with the patient (12 cases), or patients' wives (3 cases). At the time of telephone contact, all patients with AARA (or their wives) denied any history of chest cancer or chest surgery on direct questioning. Two patients with lung cancer were alive at the time of follow-up, at least four years after they participated in the survey. The

diagnosis of cancer in these two patients was confirmed by pathologic analysis of surgical specimens.

Features of patients with cancer and AARA at the time of their survey examination are listed and compared in Table I. The mean age of the two groups did not differ greatly, although the cancer patients were 5 years older on average. Both groups had long latency periods, which is partly a reflection of the criteria used to invite workers to participate in the survey. The total number of current and former smokers was similar between the two groups, as were the mean number of pack-years among smokers. It is interesting to note that those with AARA more frequently reported having stopped smoking at the time of the survey than those discovered to have cancer. Results of spirometry, respiratory symptoms, physical examination findings, the frequency of pleural fibrosis, and the distribution of ILO parenchymal profusion scores were comparable. Although some differences between those with AARA and cancer were present (such as the incidence of cough, clubbing, or former versus current smoking), there is great overlap between the groups. The number of cases involved is small and does not merit statistical inference. More importantly, none of the clinical parameters examined (Table I) would permit differentiation of cancer from AARA in individual patients.

DISCUSSION

Identification of AARA in this cohort of men with extensive exposure to asbestos and prolonged duration from onset essentially was a radiologic diagnosis, confirmed by follow-up of all cases after at least four years. Excluding radiographic appearance, cases of AARA could not be distinguished from what were determined to be newly discovered cases of lung cancer and mesothelioma. The cross-sectional prevalence of AARA was almost the same as that of newly diagnosed lung cancer.

In a radiographic survey of adults, Hillerdal identified 891 individuals with pleural changes presumed to be related to asbestos during a population survey of approximately 250,000 persons.⁹ During a ten year period of follow-up, six cases of AARA were known to have developed among the 891 patients with pleural disease. All cases of AARA were confirmed at surgery. No details regarding exposure to asbestos, latency, or other clinical parameters were provided, and no mention is made of incidence of cancer within the cohort during the same period of follow-up. The ten year cumulative incidence of AARA, $6/891 = .67\%$, is similar to the prevalence of AARA discovered among the participants of our survey (.45%). However, these numbers should not be compared directly; one represents a 10 year cumulative incidence, and the other is a cross-sectional prevalence.

Asbestos insulation workers are known to have a high lifetime risk of developing lung cancer or mesothelioma.^{1,2} AARA is a nonmalignant radiographic finding related to asbestos exposure. We have shown that the number of new cases of lung cancer and mesothelioma discovered during a survey of insulation workers is comparable to the prevalence of AARA. Among patients with a history of exposure to asbestos, clinical evaluation of suspicious lesions must be pursued aggressively. It must also be remembered that the

same population can develop AARA. Short of surgery and/or long term follow-up, the nonradiographic clinical features can be similar.

REFERENCES

1. Selikoff, I.J., Churg, J, Hammond, EC.: Asbestos Exposure and Neoplasia. *JAMA* 188:2226 (1964).

Table I
Clinical Features of Patients with Newly-Discovered Cancer and Asbestos-Associated Rounded Atelectasis Among Insulation Workers

	Cancer	AARA
Total Number of Cases	14	13
Mean Age at Examination (range)	64.5 (53-73)	59.4 (51-71)
Mean Years from Onset of Exp. (range)	40.3 (31-52)	36.2 (27-49)@
Smoking History, number (%)		
Current	6 (42.9)	1 (7.7)
Former	6 (42.9)	10 (76.9)
Never	2 (14.3)	2 (15.4)
Mean Pack-Years (smokers only)	45.1*	45.3*
Spirometry, mean percent predicted (range)		
Forced Vital Capacity	66.4 (36-105)	69.5 (37-113)
Forced Exp. Volume 1 sec.	59.4 (37-89)	62.8 (20-106)
Forced Exp. Flow 25-75	60.1 (19-112)	62.4 (9-105)
Symptoms, number (%)		
Dyspnea	10* (76.9)	10 (76.9)
Hemoptysis	1 (7.1)	1 (7.7)
Cough	8 (57.1)	5 (38.5)
Physical Examination Findings, number (%)		
Rales	11 (78.6)	12 (92.3)
Rhonchi	3 (21.4)	2 (15.4)
Clubbing	6 (42.7)	3 (23.1)
1980 ILO Radiographic Scores		
Parenchymal Fibrosis, number		
Zero (-/0, 0/0, 0/1)	1	3
One (1/0, 1/1, 1/2)	5	7
Two (2/1, 2/2, 2/3)	5	3
Three (3/2, 3/3, 3/+)	3	0
Pleural Fibrosis, number (%)	14 (100)	12 (92.3)

@ = one patient had less than 30 years

* = missing results from one case

2. Selikoff, I.J., Bader, R.A., Bader, M.E., Churg, J., Hammond, E.C.: Asbestosis and Neoplasia. *Am. J. Med.* 42:487-496 (1967).
3. Blesovsky, A.: The Folded Lung. *Br. J. Dis. Chest.* 60:19-22 (1966).
4. Tylen, U., Nilsson, U.: Computed Tomography in Pulmonary Pseudotumors and Their Relation to Asbestos Exposure. *J. Comp. Asst. Tomog.* 6(2):229-237 (1982).
5. Hillerdal, G., Hemmingsson, A.: Pulmonary Pseudotumours and Asbestos. *Acta Radiol Diagnos* 21:615-620 (1980).
6. Mintzer, R.A., Cugell, D.W.: The Association of Asbestos-Induced Pleural Disease and Round Atelectasis. *Chest* 81:457-460 (1982).
7. Schneider, H.J., Felson, B., Gonzalez, L.L.: Rounded Atelectasis. *AJR* 134:225-232 (1980).
8. Mintzer, R.A., Gore, R.M., Vogelzang, R.L., Holz, S.: Rounded Atelectasis and its Association with Asbestos-Induced Pleural Disease. *Radiology* 139:567-570 (1981).
9. Hillerdal, G.: Non-Malignant Asbestos Pleural Disease. *Thorax* 36:669-675 (1981).
10. Selikoff, I.J., Hammond, E.C., Seidman, H.: Cancer Risk of Insulation Workers in the United States. In: *Biologic Effects of Asbestos*, IARC Sci. Pub. No. 8, pp. 209-216. P. Bogovski, J.C. Gilson, V. Timbrell, and J.C. Wagner, Eds. International Agency for Research on Cancer, Lyon (1973).
11. International Labour Office: *Guidelines for the use of ILO International Classification of Radiographs of Pneumoconioses* (revised edition 1980) Occupational Safety and Health Series, No. 22. ILO, Geneva. 1980.

We are grateful to Professor Y. Suzuki for his review of histopathologic material.

CANCER MORTALITY AMONG SILICOTIC CASES

G.F. RUBINO • G. Scansetti • G. Piolatto • M. Coggiola • G.M. Giachino

Turin University, Institute of Occupational Health
A. MARCONI, National Health Institute, Rome, Italy

INTRODUCTION

This study takes into consideration the mortality related to all site cancer, to lung and laryngeal cancer, to silicosis and silico-tuberculosis, and to chronic non-malignant respiratory diseases among workers professionally exposed to silica.

The aim of the investigation is to ascertain whether a cancer mortality excess, particularly from lung cancer, exists, and to identify from which factors is affected.

The role of different working exposures and smoking habits in inducing lung cancer has been investigated.

METHODS

The Archives of Turin office of the National Institute of Insurance (I.N.A.I.L.) were examined and the clinical documentation was collected for each male worker who received compensation for silicosis and died between 1970 and 1983; 746 subjects were included in the study.

The following data were obtained: date of birth, type of occupation in industry, year of starting and ceasing exposure,

compensation year and percentage, year and cause of death through death certificate; smoking habits were also investigated.

Mortality analysis has been carried out using the Standardized Proportional Mortality Ratio (SPMR).^{1,2}

RESULTS

In Table I overall mortality data, and observed and expected deaths related to specific causes as well as Standardized Proportional Mortality Ratios (SPMR) are shown.

A lung cancer mortality excess (81 observed cases versus 59.50 expected—PMR 136; 95% C.L. 111—162) was found, together with a high mortality rate (27.8%) related to silica dust exposure.

In Tables II, III, and IV, observed and expected deaths related to specific causes are arranged according to exposure in the different working activities.

The 746 cases were divided in three groups: the first one covering mine, quarry and tunnel workers, the second one

Table I
Mortality: Overall and by Causes

	OBSERVED (%)	EXPECTED	PMR
ALL CAUSES	746 (100)	-	-
ALL CANCERS	158 (21.2)	198	80
LUNG CANCER	81 (10.8)	59.5	136 *
LARYNX CANCER	6 (0.8)	7.86	76
CHRONIC NMRD	45 (6)	46.97	95
SILICOSIS	176** (23.6)	-	-
SILICO-TB	31** (4.2)	-	-

* $p < 0.05$

** 27.8 % as mentioned in the text

Table II
Mortality: Overall and by Causes According to Job
Underground Workers and Stonecutters

	OBSERVED (%)	EXPECTED	PMR
ALL CAUSES	239 (100)	-	-
ALL CANCERS	37 (15.5)	65.41	57.6
LUNG CANCER	21 (8.8)	19.88	106
LARYNX CANCER	2 (0.8)	2.66	75
CHRONIC NMRD	4 (1.7)	14.55	27
SILICOSIS	96 (40.2)	-	-
SILICO-TB	31 (7.1)	-	-

Table III
Mortality: Overall and by Causes According to Job
Foundry Workers

	OBSERVED (%)	EXPECTED	PMR
ALL CAUSES	457 (100)	-	-
ALL CANCERS	111 (24.3)	119.65	93
LUNG CANCER	56 (12.3)	35.22	159 *
LARYNX CANCER	4 (0.9)	4.79	84
CHRONIC NMRD	36 (7.9)	29.60	122
SILICOSIS	67 (14.7)	-	-
SILICO-TB	8 (1.7)	-	-

* $p < 0.05$

covering foundry workers and the third one assembling all other remaining works in which a silicogenic risk is attributable: pottery, tile, glass, refractory material industries, etc.

According to this analysis a mortality excess from lung cancer is present only in the category of foundry workers (56 observed cases versus 35.2 expected—PMR 159; 95% C.L. 126—192); in the first group (miners, quarrymen, stonecutters) an increased mortality from silicosis and silico-tuberculosis is observed close to a markedly reduced mortality from chronic non-malignant respiratory diseases (NMRD) (4 observed cases versus 14.55 expected).

This result led to focus a few parameters, among those better documented, which could affect the lung cancer excess

confined to foundry workers. We meant particularly to stress out the possible role in inducing pulmonary neoplasm of the type of industry, and related different intensity of silica exposure, and of the smoking habits.

Information concerning smoking habits has been collected for more than 2/3 of the group under examination. Table V shows a significant mortality increase from lung cancer in smoking foundry workers: 38 observed cases versus 21.82 expected—PMR 174; 95% C.L. 132.13—215.94.

The group of non-smoking silicotic foundry workers is numerically too small to provide statistical significance to apparent mortality increase from lung cancer observed also in this group (10 observed cases versus 6.31 expected—PMR 158). Nevertheless by means of a procedure formerly used by

Saracci³ to assess expected values in cohorts of smokers and non-smokers, is possible to assume that mortality rates from lung cancer in the general population (which in Italy includes 1/2-1/3 of smokers) are at least four times greater than those of the non-smokers. Therefore lung cancer mortality risk in non-smoking foundrymen seems to be underestimated. Table VI shows the results adjusted for smoking habit, that is 10 observed cases versus 1.57 expected; this data achieves the conventional limits of statistical significance.

In Table VII lung cancer mortality has been related to exposure length. This sorting criteria shows a lung cancer mortality excess, both in the group whose exposure duration is covered between 11 and 20 years (21 observed cases versus 12.15 expected—PMR 173; 95% C.L. 116.5-229.1), and in that whose exposure duration is more than 20 years (29 observed cases versus 18.26 expected—PMR 159; 95% C.L. 113.05-204.8).

In Table VIII foundry workers have been divided in two

Table IV
Mortality: Overall and by Causes According to Job
Other Activities

	OBSERVED (%)	EXPECTED	PMR
ALL CAUSES	50 (100)	-	-
ALL CANCERS	10 (20)	13.96	71
LUNG CANCER	4 (8)	4.23	94
LARYNX CANCER	0	-	-
CHRONIC NMRD	5 (10)	3.06	160
SILICOSIS	13 (26)	-	-
SILICO-TB	6 (12)	-	-

Table V
Lung Cancer—Observed and Expected Deaths and PMR
According to Smoking Habit—Foundry Workers

	OBSERVED	EXPECTED	PMR
NON SMOKERS	10	6.31	158
SMOKERS	38	21.82	174 *

* $p < 0.05$

Table VI
Lung Cancer—O/E Deaths and PMR According to Smoking Habit
—Expected Values Adjusted for Smoking

	OBSERVED	EXPECTED	PMR
NON SMOKERS	10	1.57	636 *
SMOKERS	38	27.27	139 *

* $p < 0.05$

groups in accordance with the average exposure characteristic of job title:⁴ (1) lower risk of silica exposure (melting, furnace worker, pouring, coremaking, cut-off saw, molding, crane driving, gathering motormen, mechanical and electrical maintenance staff). (2) higher risk of silica exposure (earths and sands system, muller, grinder, chipper, sandblaster, shot blaster, tumbler, relining and repair).

In the first group the excess risk for lung cancer is statistically significant (36 observed cases versus 21.93 expected—PMR 164; 95% C.L. 122.3–206), whereas in the second group such an excess is still present but doesn't attain the conventional limits for statistical significance. Thus no relationship between lung cancer prevalence and silicotic exposure estimate seems to be present in foundry workers group.

DISCUSSION

The assumption that silica has a causal role in inducing pulmonary neoplasm is still under debate.

In a recent literature review Goldsmith⁵ agreed with this hypothesis and acknowledged that silica exposure allows an enhanced risk of developing lung cancer. In historical cohort studies^{6,7} and in a recent Italian case-referent study⁸ an overall excess risk for lung cancer was found in workers compensated for silicosis in different industrial activities.

On the other hand the same assumption has been strictly criticized by Heppleston⁹ who considered these inferences not sufficiently demonstrated, chiefly as regards the confounding effect of smoking habits. Further on, Swaen¹⁰ argues that it is unlikely that the confounding effect of smoking can explain the high relative risk for lung cancer in workers with silicosis.

This study considers silica exposure as predominant in three categories of workers, namely miners, foundry workers and employees in other industrial fields like glass manufacturing, potting and brick works, etc. For this third group it is impossible to draw valid appraisals.

Table VII
Lung Cancer—Observed and Expected Deaths and PMR
According to Exposure Duration—Foundry Workers

	1 - 10 years			11 -20 years			> 20 years		
	OBS.	EXP.	PMR	OBS.	EXP.	PMR	OBS.	EXP.	PMR
ALL CAUSES	50			146			253		
LUNG CANCER	6	4.95	121	21	12.2	173*	29	18.3	159*

* p < 0.05

Table VIII
Lung Cancer—Observed and Expected Deaths and PMR
According to Exposure Level—Foundry Workers

	high risk of silica exposure			low risk of silica exposure		
	OBSERV.	EXPECT.	PMR	OBSERV.	EXPECT.	PMR
ALL CAUSES	175			282		
LUNG CANCER	20	13.39	149	36	21.93	164*

* p < 0.05

In the first group, which is mainly formed of underground workers and stonecutters, almost exclusively exposed to silica, the collected data don't point out a mortality excess from lung cancer. This result, as far as concerns talc miners, confirms our data on miners of Piedmont (Italy Region).^{11,12} Previous researches by Goldman,¹³ Ashley,¹⁴ Enterline,¹⁵ Liddel¹⁶ and Howard,¹⁷ did not underline an increased mortality for lung cancer in coal miners. So that it may be assumed that no relationship exists between lung cancer and mine and quarry working activities, when specific carcinogenic agents (ionizing radiations, asbestos, etc.) are absent. This conclusion has been debated by Finkelstein¹⁸ who reported an increased mortality for lung cancer in an Ontario miners population compensated for silicosis; no final estimate was drawn about the possible causal role of silica dust in inducing neoplasm. No definite statements are any more expressed in the report by Thomas¹⁹ in which the role of silica itself as a cofactor in inducing lung cancer in pottery workers exposed to silica and non-fibrous talc cannot be ruled out.

On the contrary, through the analysis of data concerning silicosis cases in foundry workers, an increased mortality risk for lung cancer emerges.

This special risk does not seem solely related to smoking habit, since also in the group of non-smoking workers a significant mortality excess from lung cancer is present.

A similar result has been reported by Blot²⁰ in an investigation on a group of steel plant workers in which the mortality excess from lung cancer still persists after cigarette smoking adjustment.

Other reports confirm as well the presence of an increased lung cancer mortality in foundry workers.^{21,22,23,24,25}

In our study the enhanced mortality risk for pulmonary neoplasm does not seem related to silicotic risk: an increased risk is not present in the group of underground workers (exposed to high silica level) and a significant excess of lung cancer is present in the group of foundry workers rated at low silica exposure. This remark agrees with a Tola's²⁶ observation in which the relationship between lung cancer mortality and specific occupation is evaluated.

In conclusion we can hypothesize that in foundry workplaces other risk factors (Polycyclic Aromatic Hydrocarbons?) than silica are present and they can play a role at least concomitant in inducing pulmonary cancer.

REFERENCES

1. Kupper, L.L., McMichael, A.H., Symons, M.J., Most, B.M.: On the utility of proportional mortality analysis. *J. Chron. Dis.* 31:15-22 (1978).
2. Zeighami, E.A., Morris, M.D.: The measurement and interpretation of proportionate mortality. *Am. J. Epidemiol.* 117:90-97 (1983).
3. Saracci, R.: Asbestos and lung cancer: an analysis of the epidemiological evidence on the asbestos-smoking interaction. *Int. J. Epidemiol.* 20: 323 (1977).
4. Rubino, G.F., Pettinati, L.: *Elementi di Medicina del Lavoro*, 3rd Ed., p. 86. Minerva Medica Edizioni, Torino (1985).
5. Goldsmith, D.F., Guidotti, T.L., Johnston, D.R.: Does occupational exposure to silica cause lung cancer? *Am. J. Ind. Med.* 3:423-440 (1982).
6. Westerholm, P.: Silicosis, observations on a case register. *Scand. J. Work Environ. Health* 6 (Suppl. 2): 5-86 (1980).
7. Zambon, P., Simonato, L., Mastrangelo, G., Winkelmann, R., Saia, B., Crepet, M.: Mortality of workers compensated for silicosis during the period 1959-1963 in the Veneto region of Italy. *Scand. J. Work Environ. Health* 13:118-123 (1987).
8. Forastiere, F., Lagorio, S., Michelozzi, P., Covariani, F., Arca, U., Borgia, P., Perucci, C., Axelson, O.: Silica, silicosis and lung cancer among ceramic workers: A case-referent study. *Am. J. Ind. Med.* 10:363-370 (1986).
9. Heppleston, A.G.: Silica, pneumoconiosis and carcinoma of the lung. *Am. J. Ind. Med.* 7:285-294 (1985).
10. Swaen, G.M.H., Meijers, J.M.M.: Lung cancer risk among workers with silicosis: potential confounding by smoking habits. *Am. J. Ind. Med.* 12:223-225 (1987).
11. Rubino, G.F., Scansetti, G., Piolatto, G., Gay, G.: Mortality and morbidity among talc miners and millers in Italy. *Dusts and Disease, Pathotos. Pub.*, 357-363 (1979).
12. Rubino, G.F., Scansetti, G., Piolatto, G., Romano, C.: Mortality study of talc miners and millers. *J. Occup. Med.* 18:186-193 (1976).
13. Goldman, K.P.: Mortality of coal miners from carcinoma of the lung. *Brit. J. Ind. Med.* 22: 72-77 (1975).
14. Ashley, D.G.B.: The distribution of lung cancer and bronchitis in England and Wales. *Brit. J. Cancer* 21: 243 (1967).
15. Enterline P.E.: Mortality among coal miners in the U.S.A. *Am. N.Y. Acad. Sci.* New York (1971).
16. Liddel, F.D.K.: Mortality in British coal miners in 1961. *Brit. J. Ind. Med.* 30:15-24 (1973).
17. Howard, D., Rockette: Cause specific mortality of coal miners. *J. Occup. Med.* 19:795-801 (1971).
18. Finkelstein, M., Kusiak, R., Suranyi, G.: Mortality among miners receiving workmen's compensation for silicosis in Ontario 1940-1975. *J. Occup. Med.* 24:663-667 (1982).
19. Thomas, T.L., Stewart, P.A.: Mortality from lung cancer and respiratory disease among pottery workers exposed to silica and talc. *Am. J. Epidemiol.* 125:35-43 (1987).
20. Blot, W.J., Brown, L.M., Pottern, L.M., Stone, B.J., Fraumeni, J.F.: Lung cancer among long-term steel workers. *Am. J. Epidemiol.* 117: 706-716 (1983).
21. Gibson, E.S., Martin, R.H., Lockington, S.N.: Lung cancer mortality in a steel foundry. *J. Occup. Med.* 19:807-812 (1977).
22. Egan, Baum E., Miller, B.A., Waxweiler, R.J.: Lung cancer and other mortality patterns among foundry men. *Scand. J. Work Environ. Health* 7 (suppl. 4): 147-155 (1981).
23. Palmer, W.G., Scott, W.D.: Lung cancer in ferrous foundry workers: a review. *Am. Ind. Hyd. Ass. J.* 42: 329-340 (1981).
24. Fletcher, T: The mortality of a cohort of british foundry workers. Proceedings International Symposium *Silice, Silicosis e Cancro.* 27-43. Padova, Italy (10/5/1985).
25. Silverstein, M., Maizlish, N., Park, R., Silverstein, B., Brodsky, L., Mirer, F.: Mortality among ferrous foundry workers. *Am. J. Ind. Med.* 10:27-43 (1986).
26. Tola, S., Koskela, R.S., Hernberg, S., Jarvinen, E.: Lung cancer mortality among iron foundry workers. *J. Occup. Med.* 21: 753-760 (1979).

ALVEOLITIS IN OCCUPATIONAL LUNG DISEASES (OLD)

A. TELES DE ARAÚJO • Ana Cristina Mendes
• Jorge Tomás Monteiro • M. Freitas e Costa

Clinica de Doencas Pulmonares (FML) and CnL3—INIC
Lisbon, Portugal

INTRODUCTION

The prevalence of inhalatory pulmonary diseases, caused by many occupational and environmental exposures to organic and inorganic substances, remains a problem that may be underestimated because, in many instances, the disease has an insidious character and the host lung response protect and smoulder the clinical picture.

Although many primary industries, such as granite sheds and asbestos mines, improved control measures, the exposure remains in secondary and tertiary manufacturing trades, which use those products.

The correct diagnosis can be missed and to avoid it the physician must use all his sense of purpose and curiosity in the study of the suspect OLD patient. It is also expected that a better knowledge of the OLD mechanisms constitute the foundation for the understanding and diagnosis of these diseases.

The bronchoalveolar lavage (BAL) seems to fulfil this goal as it is now well known that the study of BAL fluid closely mimics the events happening in the interstitial space.^{4,8,9,12}

Confirming this in Extrinsic Allergic Alveolitis, it is generally accepted that the study of BALF discloses an alveolitis although it is not completely established if and how there is a correlation between the gravity of disease and the intensity of the alveolitis found. However it is considered that the increased number of effector cells found in BALF of these patients, is the local expression of the basic immunologic mechanisms of the disease, evolving to the formation of granulomas and, lately, contributing to fibrosis.^{4,11,16}

Regarding the interstitial lung diseases caused by inorganic dusts, only recently has the occurrence of an alveolitis been accepted,^{2,3,4,13,14} and Begin et al., even found that the alveolitis in subsets of silica exposed workers, with distinct clinical stages of disease, was found to have distinct biological characteristics.²

In this study we tried to evaluate the existence or not, and the type of alveolitis found in a group of 48 patients with occupational lung disease confirmed by the usual criteria. We also compared the patients with occupational history of exposition to organic dust (Group I) with the patients exposed in work environment to mineral dust (Group II). Finally

we tried to correlate the findings with clinical manifestations and evolution.

MATERIAL AND METHODS

Patients

We studied 48 patients, being 28 males and 20 females. The average age was 42 ± 13 years old, ranging from 73 to 28 years old.

Twenty-four patients had smoking habits. None of the patients had history of other concomitant pulmonary disease.

All patients were referred to the Outpatient Clinic of Occupational Diseases because of respiratory complaints and 10 (21%) had also systemic complaints—fever, weight loss and asthenia.

Thirty of the patients were exposed to mineral dusts (63%): silica (8 patients), iron (7 patients), cement (1 patient), asbestos (1 patient) and the other 13 patients to various other mineral dusts.

Eighteen patients were exposed to organic dusts (37%), mainly pigeon dregs (10 pt), wood (4 pt), cork (2 pt), wool (1 pt) and flour (1 pt).

All patients were submitted to a standard posteroanterior and lateral X-ray, read by 3 observers, according to ILO classification (10) and to a functional respiratory study by body plethysmography.

In all patients bronchofibrescopy was performed followed by bronchoalveolar lavage, being the effluent fluid recovered.

Fourteen patients, during diagnosis procedures, were submitted to a transbronchial lung biopsy.

After the diagnostic assessment in all patients with an alveolitis disclosed by BAL a treatment with corticosteroids was prescribed (Prednisone—1 mg/Kg of body weight).

Methods

Bronchoalveolar Lavage:

Briefly the BAL was performed with 200 ml saline serum, warmed up to 37°C, instilled by syringe in 4 aliquots of 50 cc, through a wedge bronchofibrescopy in a subsegment of the medium lobe followed a few seconds after by recovery of the lavage effluent proceeded by gentle syringe suction.

After remotion of mucus, cells were counted in a hemocytometer and cytocentrifuge smears were prepared and stained by May—Grunwald-Giemsa method for identification of the cellular populations.

The cellular pellet was obtained by centrifugation—500 G at 4°C during 20 minutes—washed three times with PBS balanced solution and resuspended in PBS solution at the final concentration of 5×10^6 cells/ml.

T-Lymphocytes

The T-lymphocytes and its subpopulations were characterized by indirect immunofluorescence after banding to specific monoclonal antibodies (Ortho—OKT₃, OKT₄ and OKT₈) following procedures previously described.^{7,14}

Statistical Analysis

The results are expressed as the mean \pm SD. The data were tested by the Student's test for differences between groups—and by Chi-Square test when appropriate.¹

RESULTS

The cellular analysis of BALF stated increased number of cells with a significant difference in Group I, as compared to controls (Table I), 67% of Group I and 40% of Group II patients fulfilled the criteria for an alveolus defined by a number of cells per ml of BALF superior to that of controls average + SD.

The alveolitis in both groups is mainly due to a significant increase of lymphocytes: $35.7 \pm 21.6\%$ (Group I) and $28.0 \pm 15.0\%$ (Group II). There was also a slight but not significant increase in the PMN cells. The percentage decrease on macrophages is not accompanied by a

diminishing of the absolute number of these cells; on the contrary a slight increase was found.

The observation of cytocentrifuge smears frequently proved foamy macrophage, the existence of Spontaneous Rosetts Macrophage-Lymphocyte and a number of giant cells above 3% on average.

Regarding the T-lymphocytary populations we found an increase in the number of T cells in both groups being significant in Group I. The analysis of the T-lymphocyte subsets proved a predominance of the T suppressor cells in the groups of patients leading to an inversion of T helper/T suppressor ratio. So in 16 pt (88%) of the Group I and in 26 patients (86%) of the Group II the T_H/T_S ratio was below 1 (Table II).

The incidence of a lymphocytary alveolitis was significantly higher in patients of Group I than in those of Group II: 67% and 40% respectively— $p < 0.02$ —(Table III).

In the patients with systemic symptoms the BAL disclose an alveolitis in 60% of them and a normal pattern in others 40%— $p < 0.02$ —(Table IV).

Among the 14 patients in which lung biopsy was performed alveolitis was found in the BAL of 9 patients. From these 9 patients 8 (88%) showed granulomas or lymphoplasmocytary infiltration of the alveolar septa (Table V). From the 5 patients without alveolitis in BAL only one presented granulomas in the lung biopsy (20%). The difference between the two groups is significant for a $p < 0.02$.

Besides aggressive dust evication of all patients we submitted the 24 patients with alveolitis to corticotherapy (Prednisone 1mg/Kg of body weight). Only 53% of this group of patients improved clinically and functionally, compared

Table I
Differential Cell Count—Bronchoalveolar Lavage

	GROUP I	GROUP II	CONTROLS
n ₂ cells/ml	$46.6 \pm 39.5 \times 10^4$ *	$36.3 \pm 36.0 \times 10^4$	$17.4 \pm 4.3 \times 10^4$
Macrophages	*** $56.1 \pm 21.8 \%$	*** $67.0 \pm 18.4 \%$	90.8 ± 2.2
Lymphocytes	** $35.7 \pm 21.6 \%$	*** $28.0 \pm 15.0 \%$	8.0 ± 1.6
P M N	5.4 ± 6.4	3.2 ± 5.9	1.1 ± 0.9

* S $p < 0.05$

** S $p < 0.01$

*** S $p < 0.001$

Table II
Lymphocytary Subpopulations—Bronchoalveolar Lavage

	GROUP I	GROUP II	CONTROLS
T ₃	83.9±6.5 % ***	75.2±11.3 N.S.	70.1±3.3
T ₄	32.7±12.4 *	28.2±6.3 ***	42.0±2.1
T ₈	50.8±13.7 ***	43.4±10.8 ***	26.5±1.9
T ₄ /T ₈	0.7±0.3	0.8±0.7	1.4±0.3

S * p < 0.05 S *** p < 0.001

Table III
Patients with Lymphocytary Alveolitis

	GROUP I	GROUP II
Lymphocytary Alveolitis	12 pts (67%)	12 pt (40%)
	→ p < 0.01 ←	
T ₄ / T ₈ Inversion	26 pts (86%)	16 pt (88%)
	N.S.	

Table IV
Clinic and Alveolitis

	SYSTEMIC SYMPTOMS	
Alveolitis	60%	↓
Without Alveolitis	40%	↑
		p < 0.02

Table V
Lung Biopsy and Alveolitis

	Granuloma or Lymphoplasmocitary Infiltration	Other Pathological Findings	TOTAL
Alveolitis	8 pt (88%)	1 pt (11%)	9
Normal BALF	1 pt (20%)	4 pt (80%)	5

$$\chi^2 = 6.57 \quad S ** \quad p < 0.02$$

Table VI
Treatment and Alveolitis

	ALVEOLITIS	NORMAL BALF	TOTAL
Clinical Improvement	13 pt (53%)	20 pt (83%)	33
No response or worsening	11 pt (46%)	4 pt (17%)	15
TOTAL	24	24	48

$$\chi^2 = 4.76 \quad S ** \quad p < 0.05$$

to 83% of the patients without alveolitis in BAL— $p < 0.02$ —(Table VI).

DISCUSSION

Being an heterogeneous population it is difficult, in a certain way, to take conclusions from the results. Anyway it becomes evident that an important number of OLD patients presents an alveolitis which has the same characteristics: it is an lymphocytary alveolitis. This suggests that at least some of the pathogenic pathways are similar in spite of the nature of the inhaled noxious dust. Besides, a great number of patients show an inversion of the T helper/T supressor ratio, that could indirectly demonstrate an activation of the immunologic local mechanisms of defense in almost all the studied patients.

It is easy to accept the immunologic via to the patients exposed to organic dust, but more difficult for those exposed to inorganic materials. Taking into consideration the findings that the number of macrophages is also increased besides the above referred morphologic modifications (foamy cells, rosetts lymphocytes—macrophage and numerous giant cells), we could think that the alveolar macrophages are activated. This activation can be provoked either by immunologic and

no immunologic stimulation and leads to the realization of mediators like IL₁ able to activate the T-lymphocyte.^{5,6}

Once again we found a good correlation between the histological data and the study of BALF proving the interest of this technique in the study of the interstitial lung diseases.^{9,12,15}

The fact that only 53% of the patients that presented an alveolitis in BALF improved, in despite of being under corticotherapy, is in striking contrast with the improving of 83% of the patients without alveolitis in which the only therapeutic measure was the withdrawal of the causing dust. So the BALF study has some predictive value and the existence of an alveolitis signifies, in our opinion, not only an involvement of the lung interstitium but also expresses the existence of amplification and perpetuation mechanisms centered in the activated alveolar macrophage and T-Lymphocyte.^{5,6}

In this study we found a marked increase in the T supressor cells. This is also reported by others and is common to almost all occupational lung diseases with some exceptions such as the case of berylliosis and asbestosis.^{3,4,11,14} This fact can contribute to the differential diagnosis and real meaning of this immunologic abnormality is not well established; perhaps

it signifies one attempt to brake the local immunologic processes.

In conclusion, we think that BAL is a good method to the study and comprehension of the occupational lung diseases. It contributes to the staggng and understanding of the pathogenic mechanisms.

The study of the cellularity is, although insufficient, being crucial, the study of the lymphocyтары populations and the quantification of various chemical mediators released by the different cells involved in the pathogenesis of these diseases.

REFERENCES

1. Bahn, A.K.: Basic Medical Statistics. Grune and Stratton Inc. (1972).
2. Bégin, R.O., Cantin, A.M., Boileau, R.D., Bisson, C.Y.: Spectrum of Alveolitis in Quartz—Exposed Human Subjects. *Chest*, 92:1061-1067 (1987).
3. Costabel, U., Bross, K.J., Huck, E., Cuzman, J., Mathys, A.: Lung and Blood Lymphocyte Subsets in Asbestosis and in Mixed Dust Pneumoconiosis. *Chest*, 91:110-112 (1987).
4. Crystal, R.C., Reynolds, H.Y., Kalika, A.R.: Bronchoalveolar Lavage: the Report of an International Conference. *Chest*, 89:122-131 (1986).
5. Davis, C.S.: Pathogenesis of Silicosis: Current Concepts and Hypothesis. *Lung*, 164:139-154 (1985).
6. Davis, G.S., Calhoun W.J.: Occupational and Environmental Causes of Interstitial Lung Disease. *Interstitial Lung Disease. Scharzw King, Ed., B.C. Decker Inc.*, pp. 63-109 (1988).
7. Ginns, L.C., Goldenheim, P.D., Miller, L.C. et al.: T-Lymphocyte Subsets in Smoking and Lung Cancer: Analysis by Monoclonal Antibodies and Flow Cytometry. *Am. Rev. Resp. Dis.*, 126:265-269 (1982).
8. Hunninghake, C.W., Cadek, J.E., Kawanami, O. et al.: Inflammatory and Immune Processes in the Human Lung in Health and Disease: Evaluation by Bronchoalveolar Lavage. *Am. J. Pathol.*, 97:149-206 (1979).
9. Hunninghake, G.W., Kawanami, O., Ferrans, V.Y. et al.: Characterization of Inflammatory and Immune Effects Cells in the Lung Parenchyma of Patients with Interstitial Lung Disease. *Am. Rev. Resp. Dis.*, 123:407-412 (1981).
10. ILO/UC International classification of radiographs of pneumoconiosis, 1980 No. 22 revised. Occupational Safety and Health Series. *Geneve International Labour Office* (1980).
11. Keller, R.H., Swartz, S., Schlueter, D.P., Bar-Sela, S., Fink, J.N.: Immunoregulation in Hypersensitivity Pneumonitis: Phenotypic and Functional Studies of Bronchoalveolar Lavage Lymphocytes. *Am. Rep. Resp. Dis.*, 130:766-771 (1984).
12. Reynolds, H.Y., Chretien, J.: Respiratory Tract Fluids: Analysis of Content and Contemporary Use in Understanding Lung Diseases. *Year Book Medical Publisher; Disease-a-Month*, February (1984).
13. Robinson, B.W.S., Rose, A.H., James, A., Whitaker, D., Musk, A.W.: Alveolitis of Pulmonary Asbestosis. *Chest*, 90:396-402 (1986).
14. Teles de Araujo, A., Alfarroba, E., Freitas e Costa, M.: The Role of Monoclonal Antibodies in the Study of Chronic Inflammatory Diseases Caused by Dust Inhalation. *Eur. J. Resp. Dis.*, Supl. 146:203-210 (1986).
15. Teles de Araujo, A., Raymundo, E., Rosal, Goncalves J., Correia, I., Moniz, D., Freitas e Costa, M.: Bronchoalveolar Lavage and Lung Biopsy in Interstitial Lung Diseases. 4th Congress of the European Society of Pneumology, A 166 (1985).
16. Voisin, C., Tonnel, A.B., Layette, C. et al.: Bird Fancier's Lung: Studies of Bronchoalveolar Lavage and Correlations with Inhalation Provocation Tests. *Lung*, 159:11-12 (1981).

NEW DUSTGRAVIMETER FOR UP-TO-DATE EXAMINATION OF DUST CONDITIONS AT MINING WORKING PLACES

H. VÉKÉNY

Department of Pathophysiol. Univ. Med. Sch., Pécs, Hungary

ABSTRACT

Mineral dusts originating at deep mining are polydisperse of a broad spectrum. The size of the largest particles is about 50 to 200 μm . At inspiration the particles undergo a selection according to their size: the particles exceeding 200 μm are not inhalable /H-fraction/, particles exceeding a size of 15 to 20 μm remain in the tracheobronchial tract /NPL-fraction/, granules smaller than 5 to 8 μm will be deposited in the alveolar region /A-fraction/. Selection of dust has been characterized by international conventions, i.e., the A-fraction by BMRC-characteristic.

In the case of inert and fibrogenous mineral dust environment—from the five dust fractions—the A-fraction as the risk factor for pneumoconiosis and the TB-fraction as the risk factor for “dustbronchitis” may have an importance. Therefore concentration of these two fractions has to be systematically measured. The paper presents a dustgravimeter—new in its structural composition—suitable for measuring concentration of the two fractions simultaneously and separately.

The preselector of the static dustgravimeter is a vertical /laminar/ flow-classifier, the medical collector for the selection of TB-fraction is an axial ciklon, and the postcollector for the A-fraction is a filter from microglassfiber. The installation of the gravimeter of 3 kg mass and 20 dm^3/min capacitance is under process.

No Paper provided.

MEASURES FOR THE IMPROVEMENT OF THE MEANS AND METHODS OF DUST CONTROL AND THE PREVENTION OF PNEUMOCONIOSIS IN THE COAL INDUSTRY

A.F. BELOUSOV AUCCTU

Mining Engineer, Moscow, USSR

ABSTRACT

The main cause of dust formation in mines is the constantly increasing mechanization and intensification of mineral products output, the increasing volumes of mining works using mechanical and explosion methods of mountain-mass disintegration.

The main factors determining the intensity of dust formation, are: physical-chemical properties of rocks, methods and intensity of rock disintegration, the possibility of reaching the places of dust formation by ventilation flows.

In order to create safe conditions of work according to the dust factor, ensuring the prevention of pneumoconiosis, a number of research projects is at present carried out in the USSR; new methods of mineral excavation with lower levels of dust formation are being developed, the theoretical basis of hydraulic processes of dust suppression are developed, the theoretical basis of the parameter optimization of dry methods of entrapment are developed, the methods and instruments for dust control are improved and developed.

The engineering-technical problems of the prevention of pneumoconiosis are of great importance, as they are directed at the control of its initial cause—the dust. The solution of these problems is based on the information and research of mining aerosols and physical chemistry in general, on physics and mechanics of rock and other fundamental branches of science.

No Paper provided.

UNEXPECTED SARCOIDOSIS FOLLOWING PNEUMOCONIOSIS —CLINICAL OBSERVATIONS

S. BINASCHI*† • G. Catenacci* • M.C. Bossi† • A. Rezzonico* • G. Giardina†

*Department of Preventive, Occupational and Community Medicine
University of Pavia, Italy

†Service of Occupational Medicine, Regional Hospital, Varese, Italy

ABSTRACT

The authors report two observations of workers, a cement charger and a metal sand-blaster, with clinical, X-ray and BAL findings of interstitial pneumoconiosis.

Unexpected occurrence of sarcoidotic granuloma appeared in both cases, four and two years later, respectively. The diagnosis was ascertained by means of a lung biopsy performed because of a sudden worsening of the clinical and radiological findings.

The possible relationship between pneumoconiosis and sarcoidosis will be discussed to clarify whether silica and other industrial dusts, i.e., diatomaceous earth, asbestos, talc, cement, copper, could be in some cases responsible for sarcoid-like reaction or sarcoidosis.

No Paper provided.

ASBESTOS EXPOSURE AMONG FINNISH MESOTHELIOMA PATIENTS

A. TOSSAVAINEN • M. Huuskonen • T. Tuomi • E. Vanhala • M. Virtamo

Institute of Occupational Health, Helsinki, Finland

INTRODUCTION

During the past 70 years, a total of about 175,000 tons of chrysotile, 120,000 tons of anthophyllite and 5,000 tons of amosite or crocidolite has been used in Finland. Most exposures to asbestos have occurred in construction and shipbuilding industries when asbestos-containing materials have been manufactured, installed, handled or demolished.¹ About 50,000 current or retired workers have been employed for more than ten years in such occupations.

In Finland the annual incidence rate of pleural mesothelioma is about 10 per million which shows a five-fold increase since the 1960's.² Most cases are associated with occupational exposure to asbestos, and therefore, a detailed interview and fibre analyses from lung tissues are of great importance for the diagnosis and etiology of the disease.

MATERIALS AND METHODS

Subjects

In 1986-87, forty pleural mesotheliomas (33 males, 7 females) were diagnosed at three central hospitals. The cases and 31 sarcoidosis patients as referents were interviewed and their past occupational, domestic or environmental exposures to asbestos were recorded. Unaware of the case-referent status, a team of two occupational hygienists and a medical doctor classified the data into the following categories.

- Group I Definite exposure (e.g., lagging or insulation work, asbestos spraying and manufacture of asbestos products)
- Group II Probable exposure (e.g., construction, shipyard and maintenance work)
- Group III Possible exposure (e.g., transport, garage and power plant work)
- Group IV Unlikely or unknown exposure (e.g., agriculture, forestry and office work)

Exposures with a duration of less than one month were excluded.

For 19 mesothelioma patients (mean age at diagnosis 57 years, range 42-73 years) and 10 autopsied persons (mean age at death 56 years, range 37-70 years) with no known exposure to asbestos, lung tissue samples were analyzed for the mineral fibre content with scanning electron microscopy.

Lung Tissue Analysis

At autopsy, a tissue sample of 1-5 cm³ in size was taken from the upper left lobe and stored in 4% formalin solution. A 1 cm³ piece was cut below the pleural surface, dried at

80°C for 24 hours, weighed, and ashed in a low-temperature asher (Nanotech Plasmarep 100). The ash residue was dispersed in 0.1-N hydrochloric acid, ultrasonicated and filtered on Nucleopore filters with a pore size of 0.2 micrometer. The samples were gold-coated in a Jeol JFC 1100 sputtering device and analyzed in a Jeol Temscan 100 CX electron microscope equipped with an energy dispersive X-ray spectrometer (Tracor Northern TN-5500). The fibre content was measured in SEM mode at a magnification of 5000X. The intensity ratios of Si, Mg, Fe and Na were utilized to identify the type of asbestos. All inorganic fibres with roughly parallel sides and with an aspect ratio greater than 3:1 were counted. At least 400 fields of view were included in the measurement which corresponds to an analytical sensitivity of 0.1 million fibres/g dry tissue. All liquids used in the sample preparation were filtered before use and a blank sample was added to each series of analyses.

RESULTS

In the series of 40 mesothelioma cases, 22 persons (55%) had been employed in occupations such as shipbuilding, construction and maintenance in which their past exposure to asbestos was classified as possible, probable or definite. In similar standardized interviews, 8 of 31 referents (26%) adjusted for age, sex and residential area reported some exposure to asbestos (Table I).

Amosite, crocidolite and anthophyllite were the predominant fibrous minerals in parenchymal tissue while chrysotile and inorganic fibres other than asbestos were found in some samples. The fibres were 1 to 35 µm (median 3.7 µm) in length and 0.1 to 3 µm (median 0.2 µm) in diameter and the concentration ranged from 0.4 to 370 million fibres/g dry tissue. About 35% of the particles were longer than 5 µm and the number of asbestos bodies averaged 4% of the total, coated and uncoated fibres. The highest levels (over 100 million fibres/g dry tissue) were found in an insulation worker and in two shipyard electricians. In 80% of the mesothelioma patients, the content exceeded 1 million fibres/g dry tissue. The fibre concentration was <0.1 to 0.9 million fibres/g dry tissue in 10 autopsied persons with no known exposure to asbestos who had died from unrelated causes such as myocardial infarction or suicide.

DISCUSSION

According to the criteria used in this study, 55% of the mesothelioma patients reported past occupations or tasks which may have entailed to some exposure to asbestos. In 80% of the cases, the fibre concentration in the lungs ex-

Table I
Asbestos Exposure Among 40 Mesothelioma Cases and 31 Referents

Exposure category	Mesothelioma patients		Sarcoidosis patients	
	Males	Females	Males	Females
	Definite	4	0	0
Probable	12	0	1	0
Possible	6	0	7	0
Unlikely or unknown	11	7	17	6
	<hr/>	<hr/>	<hr/>	<hr/>
	33	7	25	6

ceeded a level which may presumably arise from environmental or domestic exposure. Neither the interview nor electron microscopic analyses indicated any occupational exposure to asbestos for about 10% of the cases. The results are consistent enough and similar to those from other studies³ that the two methods, alone or in combination, can establish a valid evidence from the cumulative exposure of an individual.

REFERENCES

1. Huuskonen, M., Ahlman, K., Mattson, T., Tossavainen, A.: Asbestos Disease in Finland. *J. Occup. Med.* 22:751-754 (1980).
2. Nurminen, M.: The Epidemiologic Relationship between Pleural Mesothelioma and Asbestos Exposure. *Scand. J. Work Environ. & Health* 1:128-137 (1975).
3. Mowe, G., Gylseth, B., Hartveit, F., Skaug, V.: Fiber Concentration in Lung Tissue of Patients with Malignant Mesothelioma. *Cancer* 56:1089-1093 (1985).

FACTORS THAT MAY INFLUENCE INTERACTIONS BETWEEN MINERAL DUSTS AND LUNG CELLS

G.L. BARTLETT • J.D. Barry

Penn State University, Hershey, Pennsylvania 17033, USA

ABSTRACT

Supernatant media of dust-exposed pulmonary alveolar macrophages (PAMs) were inactive in assays for both Interleukin-1 and fibroblast growth factors (FGF). We have begun to evaluate several factors that may interfere with dust-PAM interactions.

To determine the effect of sterilization on the activity of dusts, PAMs were exposed to autoclaved dust, heat-sterilized dust or to dust that had not been heated. Supernatants from the first two groups were inactive in the FGF assay, but supernatant from PAMs exposed to unheated dusts stimulated growth of lung fibroblasts.

Recent data have revealed that freshly crushed mineral dusts possess labile free radicals that are absent in dust that has been stored for more than a few days. Suspensions were prepared of a "stale" sample of anthracite dust 867 and of a freshly ground sample of the same dust. These suspensions were instilled intratracheally into guinea pigs under general anesthesia. Two, five or eight days later, PAMs were collected from the lungs by bronchoalveolar lavage, and the cells were counted. At two and five days after instillation, all lavage suspensions contained 70 to 85% PAMs, of which 5 to 18% contained phagocytized dust particles. On day eight there were again 80-84% PAMs in all suspensions, but in the presence of "fresh" dust, 48% of PAMs had phagocytized particles in comparison to 16% in the presence of "stale" dust. A similar experiment was performed in short-term cell culture. During 24-hours, >95% of PAMs phagocytized dust particles, whether or not the dust was "stale" or "fresh." Our studies are being extended to determine the effect of (1) removing surface oil contaminants by organic extraction and (2) suspending dusts without surfactant.

No Paper provided.

ELECTRON MICROSCOPIC FINDINGS OF HYPERSENSITIVITY PNEUMONITIS

K. REIJULA* • S. Sutinen†

*Regional Institute of Occupational Health, Oulu, Finland

†Mjölbolsta Hospital, Meltolan sairaala, Finland

ABSTRACT

Ultrastructure in open lung biopsies of 13 patients with hypersensitivity pneumonitis were studied. Eleven of the patients had farmer's lung and two had been exposed to other mouldy dust. Numerous lymphocytes, macrophages and giant cells were found in the alveolar and bronchiolar lumina. Loss of microvilli on the ciliated cells, granulomas, detachment of basal cells from each other, as well as disintegration of the basement membrane could be detected in bronchioles. In the alveoles hyperplasia and hypertrophy of type II (granular) pneumocytes often loosely connected with the basement membrane, were frequently demonstrated. Disintegration of the basement membrane accompanied by detachment of the pneumocytes was found occasionally. In the interstitium lymphocytes, mast cells and plasma cells predominated. Some lymphocytes with pseudopods were detected both in alveolar lumen and in the interstitium. Mast cells were found in close connection with plasma cells occasionally. Granulomas consisting of these cells and giant cells were usually present. Foreign material resembling hyphal fragments was found in the giant cells of two patients. The present series emphasizes the role of lymphocytes, macrophages, giant cells and mast cells, in the pathogenesis of hypersensitivity pneumonitis. The presence of numerous plasma cells in the lung parenchyma suggest the possibility of local antibody response caused by exposure to inhaled antigens.

No Paper provided.

MUSCULARIZATION OF PULMONARY ARTERIES IN COAL WORKERS PNEUMOCONIOSIS

SIANG-NIAN HU, M.D. • V. Vallyathan, Ph.D. • F.H.Y. Green, M.D. • K.C. Weber, Ph.D.

Laboratory Investigations Branch, Division of Respiratory Disease Studies
NIOSH, Morgantown, West Virginia 26505, USA

INTRODUCTION

Smooth muscle hypertrophy occurs in the walls of small pulmonary arteries in coal workers pneumoconiosis (CWP), and has been suggested as a pathogenetic cause for cor pulmonale.¹ There are two types of muscular hypertrophy in the terminal pulmonary arterial tree in CWP, namely longitudinally oriented and circularly oriented smooth muscle hypertrophy. The purpose of this study is to examine the differences between their etiology and pathophysiology and to correlate the changes with right ventricular hypertrophy (RVH) in CWP. For this study, 72 autopsies without heart valvular or severe coronary lesions and without hypertensive left ventricular hypertrophy were drawn from a series of 120 unselected consecutive autopsies carried out in a southern West Virginia hospital serving mainly a coal mining community.

LONGITUDINALLY ORIENTED SMOOTH MUSCLE HYPERTROPHY

Etiology

In CWP, a longitudinally oriented smooth muscle layer or bundle may be seen in the walls of the terminal pulmonary arteries. This muscle layer is more prominent in the intimal wall, and sometimes in the adventitia, of terminal pulmonary arteries (diameter > 120 μ) than in those of small pulmonary arterioles (diameter < 100 μ). The development of such muscle fibers may be due to repeated elongation or stretch forces of the vessels as they pass around an abnormal air sac, as in emphysema, or around a fibrotic mass.^{2,3} Pulmonary hypertension and alveolar hypoxia may help to stimulate its formation. The combination of high intravascular pressure and repeated stretch forces potentially exaggerates the development of longitudinal muscle hypertrophy in the pulmonary arteries.⁴ Other factors such as smoking and chronic bronchitis may also induce some longitudinal muscle fibers in the intimal wall⁵ but they are not as abundant as in emphysema or in CWP. It is believed that the longitudinal muscle fibers could make the vessel wall more stable and help to prevent its over distension when it is subjected to repeated stretching forces.⁶

Pathologic Features

At first, a small fasciculi of longitudinally oriented muscle fibers may develop in the intima of the vessels. Such small fascicular fibers may develop into a thicker continuous band

of muscle (Figure 1) and then became separated from one another by collagen and elastic fibrils. With the passage of time, fibrous tissue progressively replaces the muscle fibers leaving the appearances of a "nonspecific intimal fibrosis." These developments in the intima are the result of activity of myofibroblasts, which have the capacity to form smooth muscle cells and secrete collagen and elastin.⁷ The ultimate outcome of the process is narrowing or occlusion of the lumen with fibroelastosis (Figure 2).

Correlation with Right Ventricular Hypertrophy

In emphysema, the development of longitudinal muscle in the pulmonary artery wall is not related to RVH and hence to pulmonary hypertension.⁸ Measurements on the non-circularly oriented muscle in coal workers' vascular lesions in an earlier study of the Appalachian region also failed to demonstrate such a correlation.^{9,10} In our recent study of 10 CWP cases with significant longitudinal muscle hypertrophy in the intimal walls of small pulmonary arteries, the thickness of such a muscle layer, expressed in percentage of longitudinal muscle area (PLA)*, did not show any correlation with RVH ($r = -0.205$) (Figure 3). This implies that the simple loss of vascular bed due to longitudinal muscle hypertrophy or intimal fibromuscular proliferation is not the main cause of cor pulmonale in CWP. The lungs may develop compensation mechanisms such as recanalization, collateral circulation or bronchopulmonary anastomosis which may ameliorate the pulmonary circulation.^{3,11} The response of longitudinal muscle to stimuli is, therefore, unlikely to constrict the vessels and hence augment the pulmonary vascular resistance as circular muscle does.

CIRCULARLY ORIENTED SMOOTH MUSCLE HYPERTROPHY

Etiology

A newly formed or hypertrophied circularly oriented smooth muscle layer may exist in the medial wall of terminal pulmonary arteries in CWP, but is usually more prominent in the segment of pulmonary arterioles (diameter < 100 μ) sandwiched between an outer original and inner newly formed elastic lamina (Figure 4). In the normal, the medial circular muscle layer exists only in the pulmonary arteries (diameter 100–500 μ), gradually turns to spiral fibers in the wall of arterioles (diameter 90–100 μ), and vanishes in small arterioles (diameter < 60 μ) after birth.¹² Hypertrophy of medial circular muscle in these vessels appears to imply

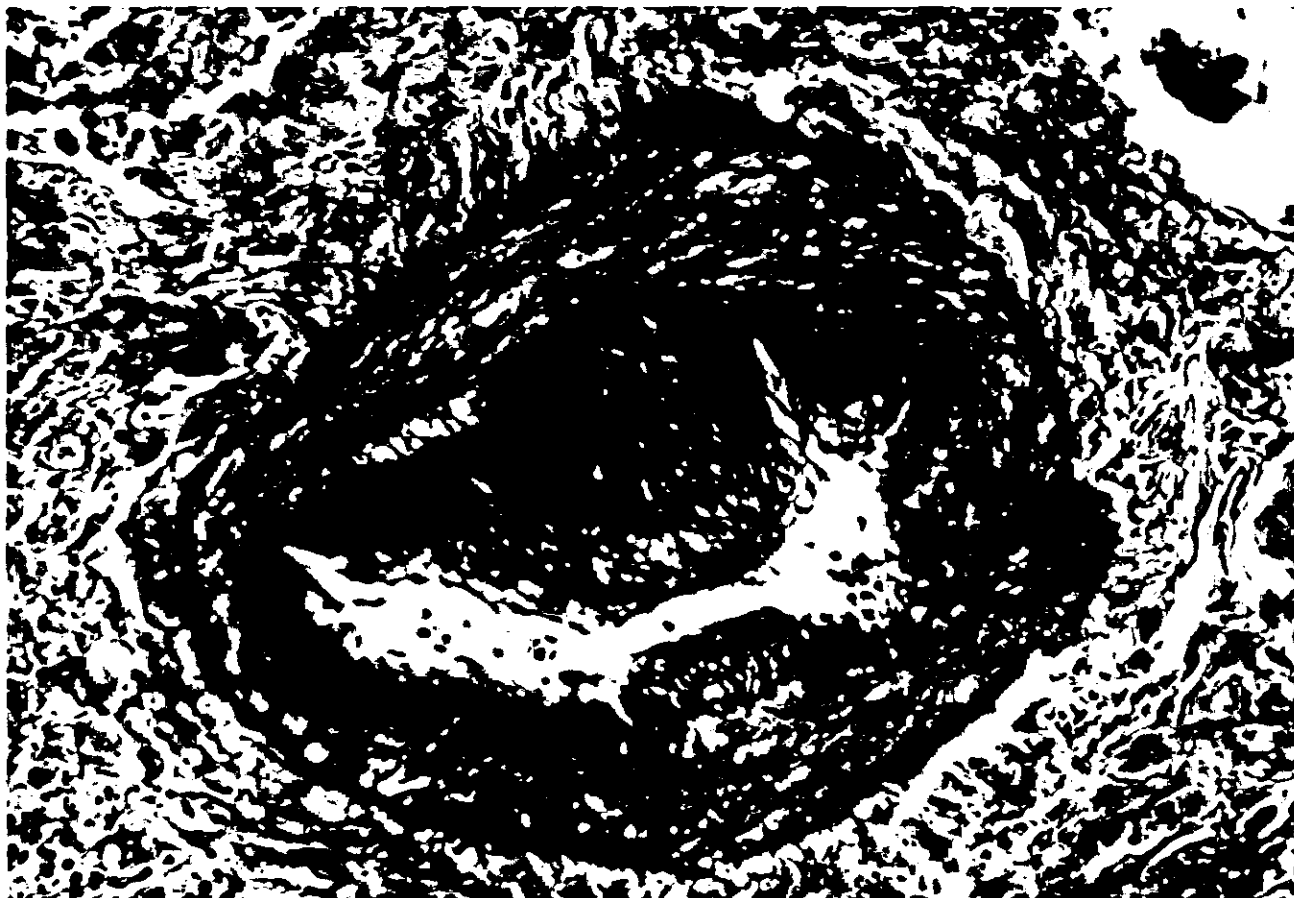

Figure 1. A 67-year-old coal worker with 25 years of underground mining exposure. He had PMF, CALD and severe emphysema with complications of cor pulmonale and right ventricular failure. Note the band of longitudinal smooth muscle in the intimal wall of a small pulmonary artery located in fibrotic tissue. (Van-Gieson elastin stain) (380X).

active vasoconstriction and increased muscular work intermittently or continuously for a prolonged time.¹³ The most potent stimulant is chronic alveolar hypoxia which causes the terminal pulmonary arteries to constrict and gives rise to an increased quantity of smooth muscle in the medial layer.^{5,9,14} Another stimulant is pulmonary hypertension, that is, the small arteries will also constrict in response to a sudden increase in pressure.¹⁵ There are genetic differences in the responsiveness of the pulmonary circulation to hypoxia, pulmonary hypertension and other various physiological and pathological stimuli.^{16,17} The pulmonary vascular resistance of individual CWP may be modified by many factors.

Pathophysiology

In CWP, especially in progressive massive fibrosis (PMF) or complicated with other chronic airway lung diseases (CALD), such as chronic bronchitis, bronchiolitis, bronchiectasis and pulmonary tuberculosis, disorders of ventilation and perfusion and decreases of diffusing capacity may be severe

enough to cause chronic alveolar hypoxia and hypoxemia.^{18,19} Chronic hypoxemia and pulmonary hypertension may exert their functional effects throughout the entire pulmonary arterial tree, but the most reactive part is at the arterioles both in affected and normal areas (Figure 5).²⁰ Although the presence of a hypertrophied medial muscle layer does not cause constriction, once it is stimulated, a thicker circular muscle layer has a stronger contraction. Thus, a vicious cycle between constriction, medial hypertrophy and pulmonary hypertension will be formed leading to RVH.⁴

Correlation with Right Ventricular Hypertrophy

There are close correlations between the development of arteriolar muscularization and RVH in emphysema as well as in CWP.^{7,21,22} This suggests the possibility that such muscularization represents the organic basis for the increased pulmonary resistance in these diseases. The percentage of medial wall thickness (PMT) in pulmonary arterioles (diameter <100 μ) of 57 coal miners and 15 controls in

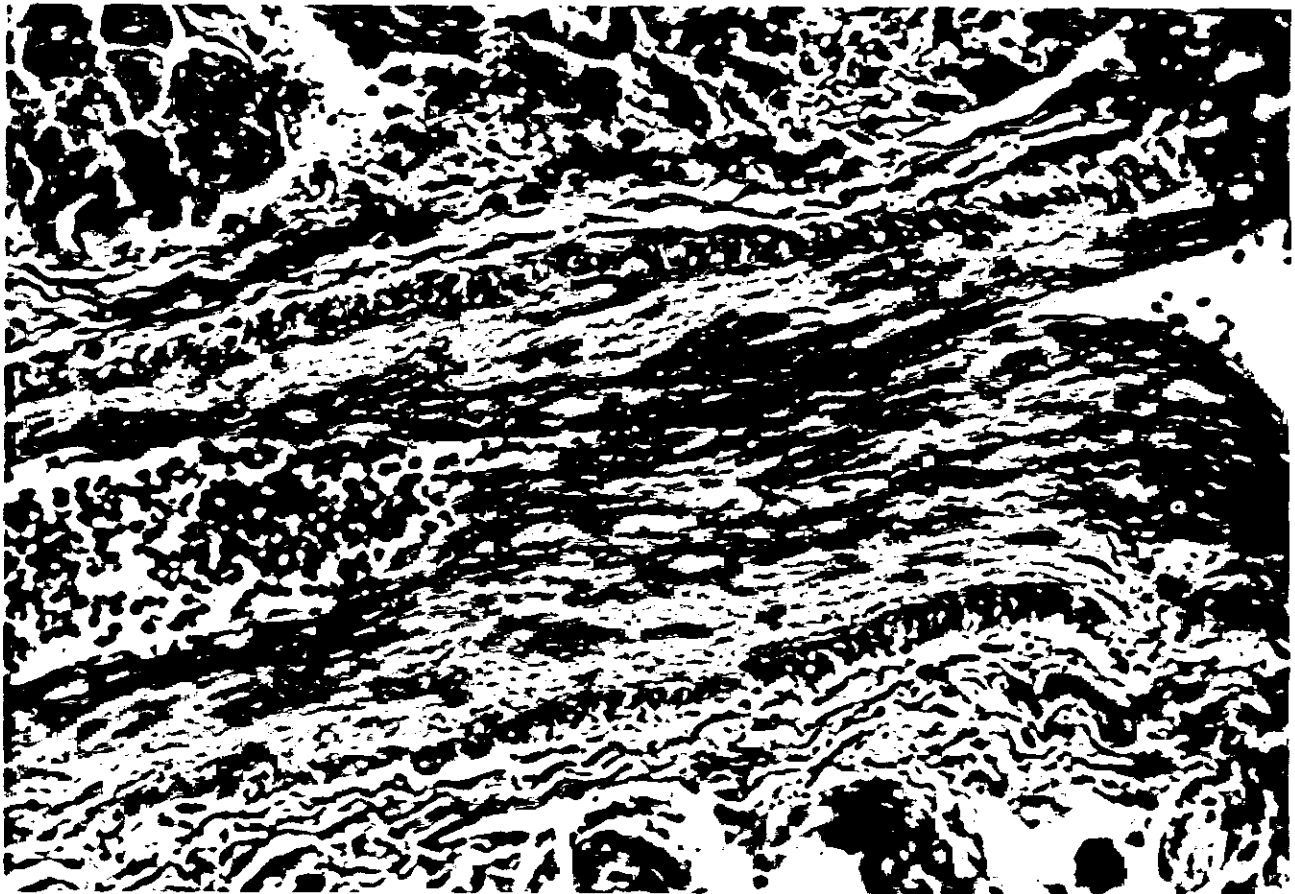

Figure 2. A 65-year-old coal miner with 35-years of underground exposure shows nodular lesions of CWP and silicosis. The severe intimal longitudinal smooth muscle hypertrophy appears to occlude the lumen of a small pulmonary artery. (Masson stain) (380X).

the Appalachian region were recently evaluated with a standard stereology program and showed a high correlation with the RV weight in percentage of LV weight (RV/LV).²² When the cases were grouped according to the literature of RVH index into normal (RV/LV < 74%), mild (RV/LV = 75-79%), moderate (RV/LV = 80-89%) and severe (RV/LV > 90%)^{1,23} with comparable average ages and underground exposure years, the mean PMT increased from 23 to 33, 36 and 40%, respectively ($p < 0.001$) (Table I).

On the other hand, medial thickness of small pulmonary arteries with external diameter larger than 100μ (grouped into $101-300\mu$ and $301-500\mu$) in 25 CWP cases showed less or no correlation with the incidence of RVH ($r=0.4690$ and 0.0726 respectively), while those of pulmonary arterioles (diameter $< 100\mu$) showed a significant correlation with RVH ($r=0.8146$) (Figure 6).

Right Ventricular Hypertrophy in Different CWP and Controls

In the same study,²² progressive massive fibrosis (PMF) caused a higher incidence of moderate and severe RVH than simple CWP did, 60% vs 16%. When they were complicated with chronic airway and lung diseases, both incidences of RVH increased, 87% vs 54% (Table II).

CONCLUSION

Circular smooth muscle hypertrophy in the medial wall of pulmonary arterioles (diameter $< 100\mu$) showed a high correlation with the incidence of RVH in 57 CWP and 15 controls from the Appalachian region. Intimal longitudinal muscle hypertrophy, or medial circular muscle hypertrophy in small pulmonary arteries (diameter $> 100\mu$), did not show such correlation with RVH.

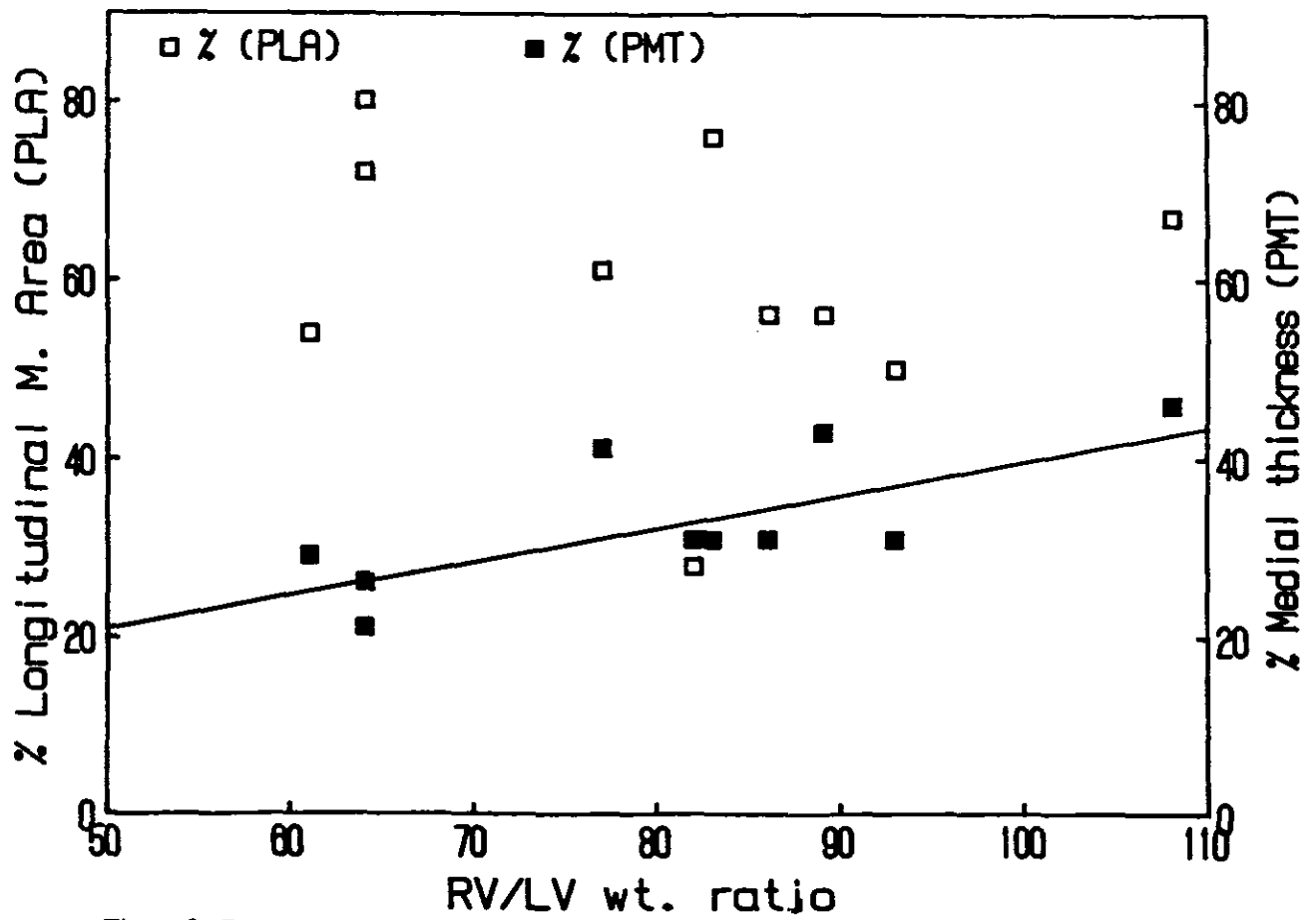

Figure 3. Correlation between RV/LV wt. ratio and percentage longitudinal muscle area (PLA) and percentage medial thickness (PMT) in 10 CWP.

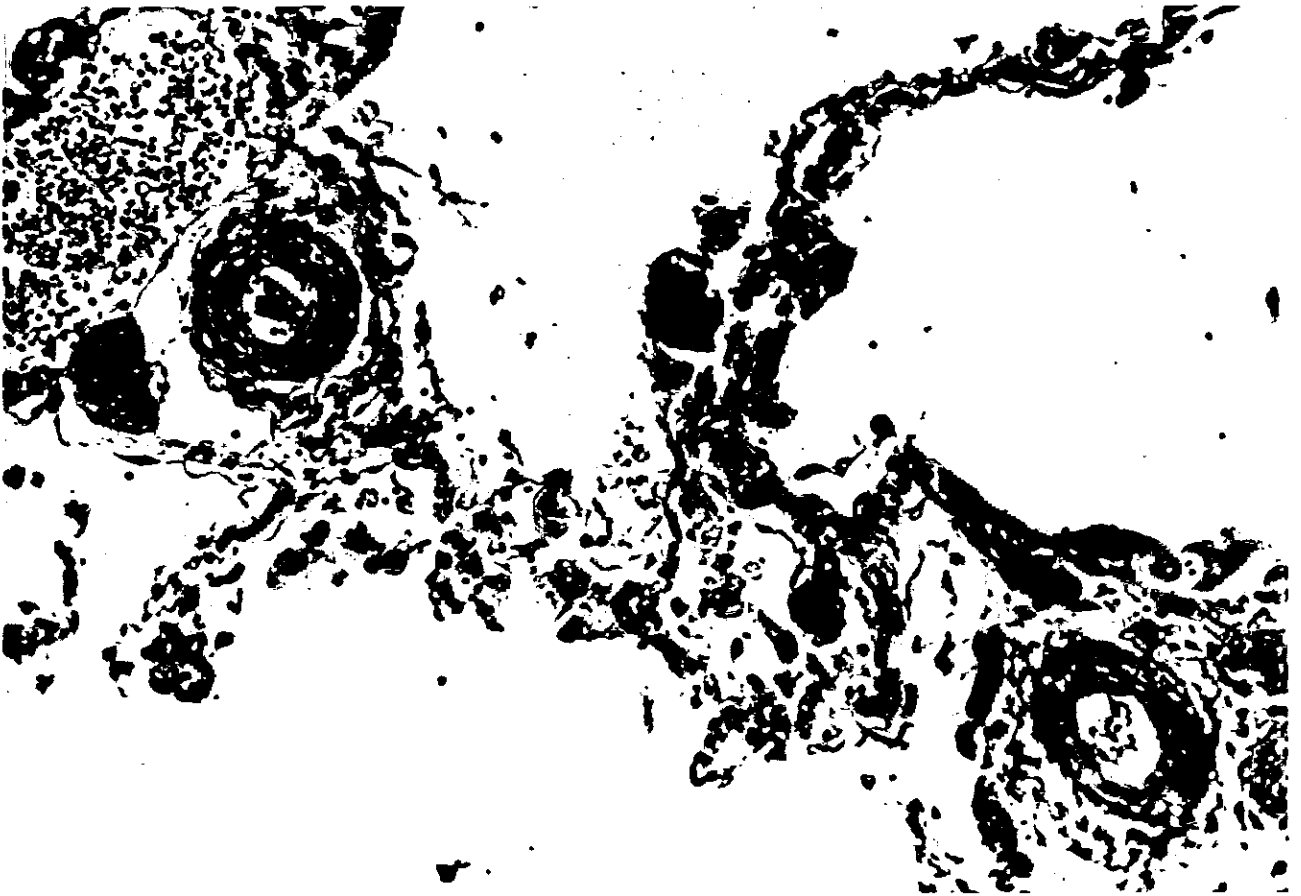

Figure 4. A 78-year-old coal miner with 25-years of underground exposure who had severe PMF and cor pulmonale. Note the medial hypertrophy of his pulmonary arterioles. (Van-Gieson elastin stain) (240X)

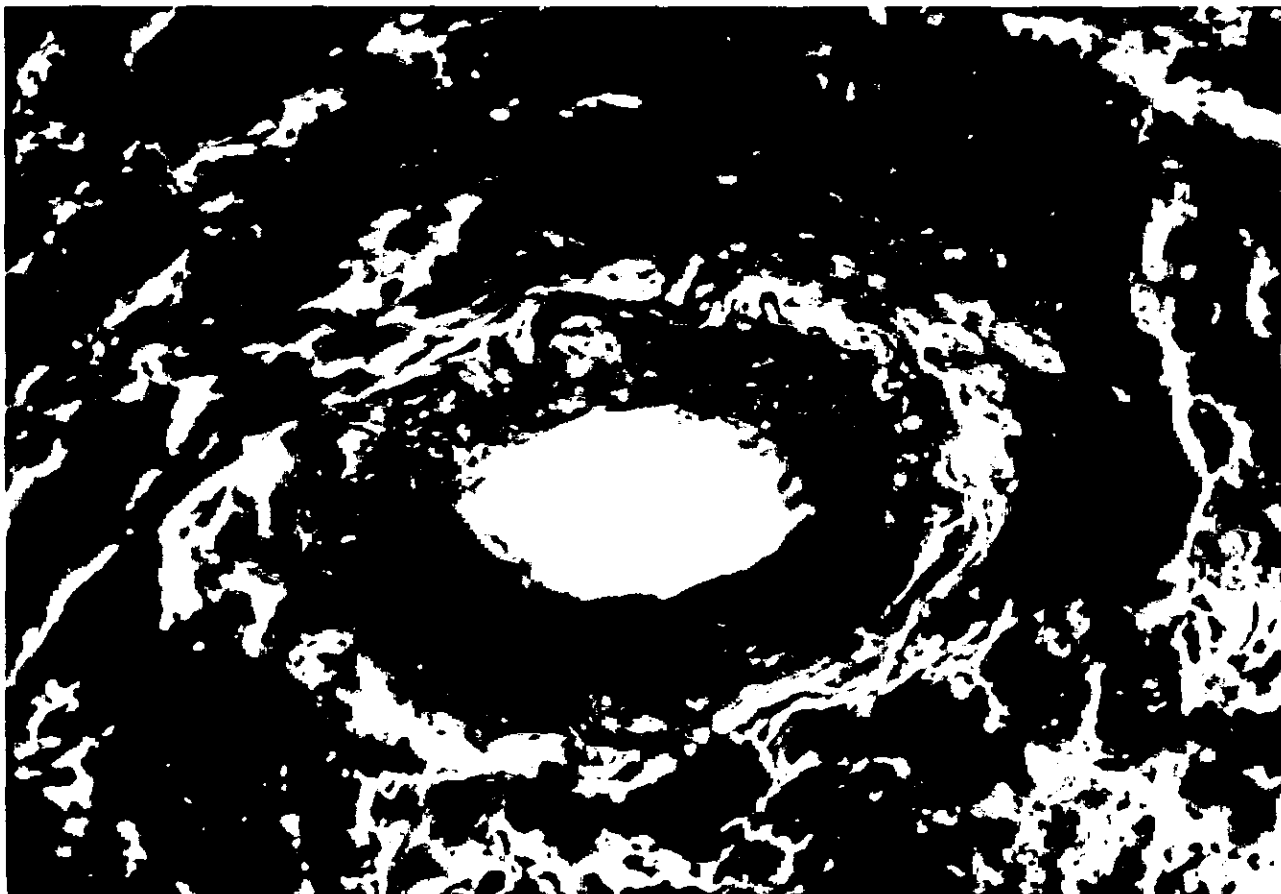

Figure 5. A 69-year-old coal miner with 45-years of underground exposure and CWP, CALD and mild cor pulmonale. Notice the arteriolar muscularization within a macular lesion. (V.G. stain) (960X)

Table I
The Severity of RVH of 57 CWP Cases (in 4 groups) Correlated with Other Parameters

	GROUP I	GROUP II	GROUP III	GROUP IV
COR PULMONALE (RVH)	NORMAL	MILD	MODERATE	SEVERE
RV/LV WEIGHT RATIO:	<74%	75-79%	80-89%	>90%
CASES	17	10	13	17
AGE	67±9 [♦]	68±11	68±6	66±7
UNDERGROUND				
EXPOSURE (YRS)	32±8	39±10	37±9	33±7
RV/LV (%)	60±10	77±1	85±3	104±16
RV FAILURE (CASES)	0	1	8	15
PMT (%)	23±8	33 ^Δ ±5	36 [†] ±5	40 [§] ±6

♦ mean ± standard deviation

Δ statistically significant (P < 0.05) from Group I

† statistically significant (P < 0.05) from Group I and II

§ statistically significant (P < 0.05) from Group I, II, and III

Table II
Incidences of RVH and Mean PMT in Different CWP and Controls

Diff. Lung Dis.	RVH (RV/LV > 80%)		Mean RV/LV (%)	Mean PMT (%) ± (SD)
	(%)	(cases)		
PMF-CALD	87	14/16	94	38.6 ± 6.6
PMF	60	3/5	83	31.8 ± 9.5
CALD-Simple CWP	54	13/24	79.5	31.9 ± 7.3
CALD	30	3/10	73.5	27.0 ± 9.5
Simple CWP	16	2/12	69.8	27.2 ± 9.5
Normal	0	0/5	< 60	10.9 ± 2.5

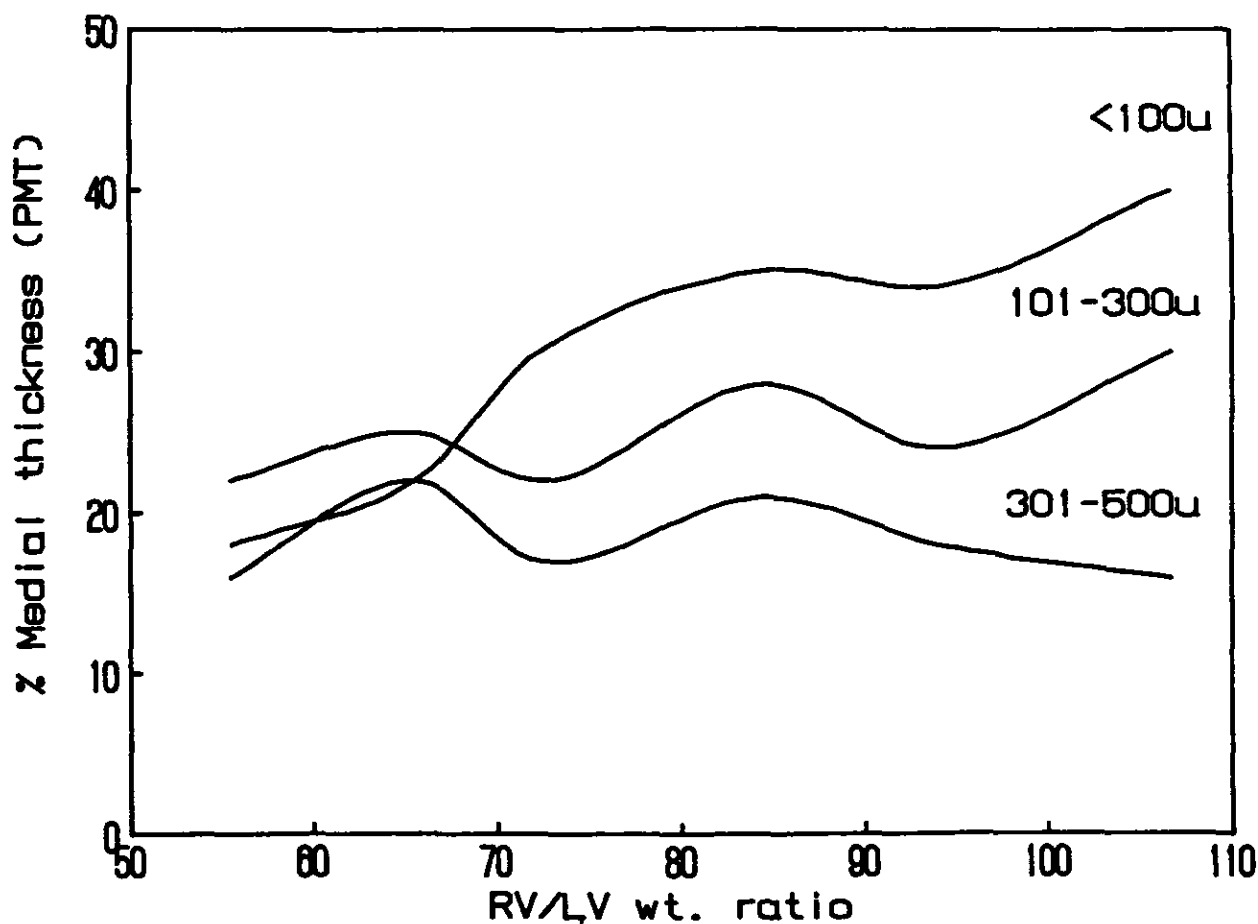

Figure 6. Correlation between RV/LV wt. ratio and percentage medial thickness (PMT) of terminal pulmonary arteries in diameters <100, 101-300 μ and 301-500 μ in 25 CWP cases.

REFERENCES

1. Thomas, A.J., James, W.R.L.: The Right Ventricle and the Small Pulmonary Arteries in Coal Workers. *B. Heart. J.* 20:403-410 (1958).
2. Dunnill, M.S.: An Assessment of the Anatomical Factor in Cor Pulmonale in Emphysema. *J. Clin. Pathol.* 14:246-258 (1961).
3. Heath, D., Smith, P.: Pulmonary Vascular Disease Secondary to Lung Disease, in Moser K.M. (ed): *Pulmonary Vascular Diseases*, pp. 407-415. Marcel Dekker Inc., New York (1979).
4. Harris, P., Heath, D.: The Relation Between Structure and Function in the Blood Vessels of the Lung in Pulmonary Hypertension, in: *The Human Pulmonary Circulation, Its form and function in health and diseases*, 3rd ed., pp. 284-297. Churchill Livingstone, Edinburgh (1986).
5. Naeye, R.L., Delliger, W.S.: Pulmonary Arterial Changes With Age and Smoking. *Arch. Pathol.* 92:284-288 (1971).
6. Burton, A.C.: Relation of Structure to Function of the Tissues of the Wall of Blood Vessels. *Physiol. Rev.* 34:619 (1954).
7. Harris, P., Heath, D.: The Pulmonary Vasculature in Emphysema, in: *The Human Pulmonary Circulation*, 3rd ed., pp. 507-521. Churchill Livingstone, Edinburgh (1986).
8. Hicken, P., Heath, D., Brewer, D.B., Whitaker, W.: The Small Pulmonary Arteries in Emphysema. *J. Pathol. Bacteriol.* 90:107 (1965).
9. Naeye, R.L., Laqueur, W.A.: Chronic Cor Pulmonale: Its Pathogenesis in Appalachian Bituminous Coal Workers. *Arch. Pathol.* 90:487-493 (1970).
10. Kleinerman, J. et al. (eds): Pathology Standards for Coal Workers Pneumoconiosis: Reports of the Pneumoconiosis Committee of the College of American Pathologists to the National Institute for Occupational Safety and Health. *Arch. Pathol. Lab. Mea.* (special issue) 103:375-429 (1979).
11. Turner-Warwick, M.: Precapillary System Pulmonary Anastomosis. *Thorax.* 18:225-237 (1963).
12. Wagenvoort, C.A., Wagenvoort, N.: Pulmonary Vascular Bed: Normal Anatomy and Response to Disease, in Moser K.M. (ed): *Pulmonary Vascular Diseases*, pp. 14-26. Marcel Dekker Inc., New York (1979).
13. Harris, P.: Patent Ductus Arteriosus With Pulmonary Hypertension. *B. Heart. J.* 17:85 (1955).
14. Naeye, R.L., Greenberg, S.D., Valdivia, E.: Small Pulmonary Vessels in Advance Pulmonary Emphysema. *Arch. Pathol.* 97:216-220 (1974).
15. Johansson, B.: Vascular Smooth Muscle Reactivity. *Ann. Rev. Physiol.* 43:359 (1981).
16. Grover, R.F., Vogel, J.H.K., Averill, K.H., Blount, S.G.: Pulmonary Hypertension, Individual and Species Variability Relative to Vascular Reactivity. *Am. Heart. J.* 66:1 (1963).
17. Heath, D., Smith, P., Rios Dalenz, J., William, D., Harris, P.: Small Pulmonary Arteries in Some Natives of La Pazi Bolivia. *Thorax.* 36:599 (1981).
18. McNeill, R.S., Rankin, J., Forster, R.E.: The Diffusing Capacity of the Pulmonary Membrane and the Pulmonary Capillary Blood Volume in Cardiopulmonary Disease. *Clin. Sci.* 17:465-482 (1958).
19. Bates, D.V., Varis, C.J., Donevan, R.E., Christie, R.V.: Variations in the Pulmonary Capillary Blood Volume and Membrane Diffusion Component in Health and Disease. *J. Clin. Invest.* 39:1401-1412 (1960).
20. Wagenvoort, C.A., Wagenvoort, N.: Pulmonary Vascular Bed: Normal Anatomy and Response to Disease. In Moser K.M. (ed): *Pulmonary Vascular Diseases*. p. 48. Marcel Dekker Inc., New York (1979).
21. Hicken, P., Heath, D., Brewer, D.B., Whitaker, W.: The Small Pulmonary Arteries in Emphysema. *J. Pathol. Bacteriol.* 90:107 (1965).
22. Hu, S.N., Vallyathan, V., Green, F.H.Y., Weber, K.C., Laqueur, W.:

Pulmonary Arteriolar Muscularization in Coal Workers Pneumoconiosis (CWP) and Its Correlation With Right Ventricular Hypertrophy. (unpublished)

23. Wells, H.A., Laqueur, W.A.: Right Ventricular Hypertrophy in West Virginia Coal Miners. *U.S. Dept Health Education and Welfare* (1966).

ACKNOWLEDGEMENTS: This study was done while Siang-nian Hu was a research associateship of the National Research Council.

The authors thank Martha Saab, Lunette Utter and Patricia Turner, for their secretarial and technical assistance.

APPENDIX

$$* \quad PLA = \left(1 - \frac{\text{Peri. Lumen}^2}{\text{Peri. Int.}^2} \right) \times 100\%$$

where, PLA is the longitudinal muscle area in the percentage of original intact lumen area bounded by internal elastic lamina; Peri. Lumen and Peri. Int. are perimeters of the remaining lumen and internal elastic lamina respectively.

Since:

$$PLA = \frac{\text{Longitud. Muscle Area}}{\text{Original Lumen Area}} \times 100\%$$

and,

$$\text{Longitud. Muscle Area} = \text{Original Lumen Area} - \text{Remaining Lumen Area}$$

$$\text{Original Lumen Area} = \left(\text{Peri. Int.} / 2\pi \right)^2 \pi$$

$$\text{Remaining Lumen Area} = \left(\text{Peri. Lumen} / 2\pi \right)^2 \pi$$

therefore,

$$PLA = \frac{\text{Original Lu. Area} - \text{Remain. Lu. Area}}{\text{Original Lu. Area}} = 1 - \frac{\text{Remain. Lu. Area}}{\text{Orig. Lu. Area}}$$

$$= 1 - \frac{\left(\text{Peri. Lu.} / 2\pi \right)^2 \pi}{\left(\text{Peri. Int.} / 2\pi \right)^2 \pi} = \left(1 - \frac{\text{Peri. Lumen}^2}{\text{Peri. Int.}^2} \right) \times 100\%$$

STUDY OF SILICOSIS IN THE INDUSTRIAL DISEASE HOSPITAL (ESI HOSPITAL) MADRAS

A. DURAIRAJ, M.D.

Physician, IMCU and Toxicology, Govt. General Hospital, Madras,
Reader in Medicine, Madras Medical College, Madras—3

ABSTRACTS

14 cases of silicosis who were working in Madras Stone Industry is reported. Only four cases were suffering from silicosis and 10 from solice tuberculosis. They were all working in the industry for a period of 10 to 20 years. 85.7% were in the 40–49 age group. X-ray mottling in 85.7% of cases. Sputum AFB positive in 71% of cases.

With the positive history of occupation in the stone industry with quartz crystals, feldspar and dried dust of finely powdered material, the cases were investigated. Chest X-ray, sputum analysis and lung biopsy were done to confirm the diagnosis. Literature of silicosis is reviewed.

MATERIALS AND METHODS

Patients who are referred for symptoms of chest disease are examined after getting detailed history of their stone-dust exposure. Blood examination, sputum examination and radiological examination were done in all the cases. Radiological, findings with a positive occupational exposure history were taken as confirmatory of the diagnosis. Lung biopsy, though done in one case, is not indicated in all the cases.

CASE REPORT

Case I

Mr. M, 38 years old working in a factory at Porur, Madras, came to the hospital first on 29/10/85 with the complaints of cough with expectoration and chest pain of one month duration. O.E. Afebrile, few scattered rales heard at the apices. Sputum-AFB negative; TC-8600/cells. P 65 to 20 E15 ESR-12/30 for half and one hour. X-ray chest PA view-mottling over both lung fields, more dense at the apices. Diagnosis of miliary tuberculosis was made and treatment started with INH/SM and Eifa with Prednisolone. He was on treatment regularly; On 29/9/86 he came with cough and chest pain of one month duration. O.E. Afebrile, R.S. few rales heard TC-8800/cm DC-P62 L30 E8 ESR/32/72 for one and one-half hour sputum AFB-negative: X-ray chest PA view increased mottling with fibrosis of both lung fields with dense hilum; occupational history—worked as rolling shift worker for more than twenty years. Operator for mixing of sand and stones into fine powder; white stones (quartz), red stones (feldspar) and sands are mixed and made into powder form. Lung biopsy was done by Menghini's aspiration needle. Occupational history with clinical features, the diagnosis of Silico-tuberculosis was made.

Case II

Mr. S, 36 years—working in the above company as Grinder Operator. C/O cough with minimal sputum of one month duration R.S. Rales over high infraclavicular area present. TC-9400/10mm DC-P50 L 34-E-16 ESR 3/7mm for half and one hour sputum for AFB negative. Culture negative, X-ray chest PA view shows right special hazziness with rounded densities all over lung fields suggestive of Silico-tuberculosis.

Case III

Mr. P, 30 years—working in the above company; sand stones are pressed into moulds, trimming is also done under pressure in the heat room. Mantoux-negative, sputum AFB-negative TC 8400 DC: P60 L30 E10 ESR 7/14, half an hour C.S. No growth in culture, X-ray chest PA view patch of opacity right base.

Tables I, II, and III indicate that 85.7% were in the 40–49 years of age group and X-ray evidence also 85.7%. Sputum possibility of AFB is 71%.

Table I
Age Incidence

Age	No. of Cases	%
20–29	0	—
30–39	2	14.2%
40–49	12	85.7%

Table II

Chest X-ray	No.
Mottling—both lungs	12.85%
Patchy Opacity—Pneumonia	2–14%

Table III
Investigations

Sputum—AFB	10	71.4%
ESR	7	50.0%

Case IV

Mr. K, 36 years—working in the above industry for twelve years. Had treatment for tuberculosis with history of cough and expectoration for one year. Now on examination he is afebrile R.S. Rales over infraclavicular area present. Mantoux negative, sputum AFB negative. Culture—No organism grown; X-ray chest PA view shows fine reticular pattern over both lung fields. With a positive history of occupation in the above industry with exposure for more than twelve years diagnosed as silico-tuberculosis and treatment started.

DISCUSSION

Silica may exist in the combined forms called SILICATES which are themselves fibrogenic. It is respirable free silica incrySTALLINE forms that causes SILICOSIS. Quartz, crystals (white stones), Feldspar (red stones) and dried dusts of finely powdered materials may become airborne before wetting or after drying.

PATHOGENESIS

When silica particles are installed and deposited in the lung periphery, they are ingested by macrophages. They enter these cells surrounded by an envelope of all membrane, the phagosome. Enzymes are secreted into this envelope; Silica particle destabilizes the membrane, which ruptures and release these enzymes into the cytoplasm, killing the cell. Cell rupture releases the silica particles into the environment where they are encountered by successive waves of macrophages that meet the same fate. The process continues until macrophages can no longer reach silica particles. This can result, if silica is localized and resulting tissue reaction forms an effective barrier. What properties of silica accounts for cyto-toxicity? Angularity and sharpness of the crystals and silicic acid may cause rupture of macrophages—Fibrosis may be due to fibrogenic factor released from dusted macrophages. Silica by altering the immune system provide supply of macrophages to an area containing silica. Silicotic lesions contain plasma cells and immune globulin.

PATHOLOGY

In the chronic form of silicosis, the characteristic lesion is the silicotic nodule. These are more numerous in the upper lobes. Lesions consists of concentric whorls of hyalinised, relatively acellular material.

Outside this zone of cellular connective tissue infiltrated with lymphocytes. Central hyalinised zone may contain some silica and most of the particles are found in the periphery.

IN SIMPLE SILICOSIS

The disease does not progress beyond the state of isolated silicotic nodules. Silicotic nodules become conglomerate forming masses of organizing fibrous tissue. This process called progressive Massive Fibrosis (PMF) attended by Massive obliteration of underlying lung tissue.

SILICO-TUBERCULOSIS

Mycobacterial infections may complicate silicosis because of the central role of macrophages in defense of the lungs against those infecting organisms.

Accelerated silicosis: seen in circumstances of more intense exposure—Progression is faster.

Acute Silicosis is due to heavy exposure to respirable free silica.

Silicotic lymphonodes may contain silicotic nodules.

CLINICAL FEATURES

1. Breathlessness on exertion.
2. Cough
3. Little sputum.

X-ray (1) rounded small opacity -1.5 mm; (2) Enlargement of hilar lymphnodes-nodes have peripheral calcification egg-shell pattern; (3) PMF—Coalescence of rounded small opacities to form larger aggregates bilateral and upper zones. They lead to large pneumoconiotic opacities; (4) These masses begin to contract, leaving clear spaces between their lateral margins and pleural surface (Angel Wings) appearance produced by sub-pleural emphysema and contracting large opacities; (5) Later leads to shrunken lungs and kinking of trachea; (6) Calcification rarely in silicotic nodules enhancing their radiographic visibility; (7) Acute silicosis produces lung consolidations in middle and lower zones.

PHYSIOLOGY

Obstruction, mixed obstruction and restriction, and restriction or pure restriction lead to abnormal spirometric tests.

COMPLICATIONS

1. Infections include tuberculosis and nocardia commonly.
2. High risk of developing collagen disease.
3. FMF leads to pneumothorax bronchopleural fistula, chronic cor pulmonale and respiratory failure.

PROGNOSIS

Is guarded because of progression of fibers is despite cessation of silica exposure. A patient with silicosis and positive tuberculin reaction has high risk of developing active P.T. and PMF.

TREATMENT

There is no satisfactory treatment for established fibrosis due to silica. Surveillance and treatment for complicating infections are indicated. Further exposure in fibrogenic dust is to be stopped. Jobs and habits (e.g.) sucking, that increase the risk of developing obstructive lung disease should be avoided.

REFERENCES

1. Dauber, J.H.: Silicosis in Update-Pulmonary diseases and disorders, A.P. Fishman (ed) New York, McGraw-Hill, 1982, pp. 149-166.
2. Guideline for the use of International Labour Office—classification of radiographs of pneumoconiosis occupation safety and health sciences, 22 (Revised 1980).
3. Rom, William N.: Environments and Occupational Medicine, 197-205, First edition 1983.

ON THE BLASTOMOGENIC CAPABILITY OF SUBMICROSCOPIC ASBESTOS DUST: IS ITS FIBROUS STRUCTURE THE ONLY PHYSICAL PROPERTY DETERMINING ITS BLAST POTENTIAL?

K. KOLEV

Institute of Hygiene and Occupational Health, Medical Academy, Sofia, Bulgaria

ABSTRACT

Ground to complete isometry and submicroscopicity of fibres after the author's own method (soft aqueous medium grinding) crocidolite (UICC), Bulgarian and Soviet antophyllites were injected intraperitoneally and intrapleurally in Wistar domestic line white rats. The percentage of induced mesotheliomas of the intraperitoneal method was 22, while that of the intrapleural one was 12. The investigations on the experimental dusts carried out at the Berghau-Forschungsinstitut in Essen, West Germany, under the personal supervision of Prof. Dr.rer.nat. K. Robock, indicated that when subjected to observation under screen electron microscope all specimens showed no fibrous structure, while electron sonde investigations indicated that the isometric material had the same chemical composition as the initial one. These results give grounds to assume that in spite of the importance of the length and diameter of fibres in asbestos blastomogenesis, experimentally proved by Stenton and other authors, they are not the only and most substantial determining factor. Purposeful investigations on this problem are necessary.

No Paper provided.

INFLUENCE OF CHEMICAL/THERMAL PRETREATMENT ON THE CYTOTOXICITY OF COALMINE DUSTS

F. TILKES • E.G. BECK

Institute of Hygiene, University of Giessen, FRG

SUMMARY

Investigations of mine dusts have partly yielded great discrepancies between the effects in humans and experimental animals on the one hand and cytotoxicity in vitro on the other hand. With the aid of chemical and thermal pretreatment it was attempted to simulate the demasking and metabolic processes occurring in vivo. Furthermore it is demonstrated that an increased information can be obtained by using a wider spectrum of concentrations and modifications of culture conditions.

INTRODUCTION

The results of earlier studies and the related observations that

- Great discrepancies exist in the evaluation of the cytotoxicity on the one hand, and of the animal experiments on the other (1,2,3,4,5,6, 7 and that
- The cell toxicities determined for a series of dusts depend very heavily on the conditions in the cell cultures and the dust dose^{8,9,10,11}

induced us to try to characterize the cytotoxicity of high-rank and low-rank mine dusts from the Saar and Ruhr coalfields more accurately via their dose dependence and the effect of chemical and thermal pretreatment.

MATERIALS AND METHODS

Two groups of dusts were selected for the chemical and thermal treatment:

Group A: Dusts which caused higher reactions for one parameter in the animal experiments than for two parameters in the in vitro test, and

Group B: Dusts which, in comparison to Group A, caused a lesser reaction for the one parameter in the animal experiment than in the corresponding two parameters of the in vitro test, which exhibited either the same or a stronger reaction.

The parameter for the animal experiment was the measure of the quartz-typical dust deposition area in the lymph node test as described by Hilscher.¹⁴ The parameter in the in vitro test was the TTC test, i.e., the influence on the reduction activity of the cells to 2, 3, 5-triphenyl-tetrazole chloride (TTC) and the pO₂ test, i.e., the polarographic measurement of the oxygen consumption (Table I,^{12,15}).

The dusts were subjected to ultrasonic treatment for a total of 70 hours at a temperature of 38°C in each of 30% H₂O₂, 100% acetone, 5 n HCl, 5 n NaOH, 5% RBS (detergent) and in double distilled water. Finally they were washed out

four times at 3500 rpm ($g = 1500 \text{ m/sec}^2$) in double distilled water + 0.01 RBS and dried at 100°C.

As cytotoxic parameter we used the release of cytoplasmatic lactic dehydrogenase (LDH) of guinea pig alveolar macrophages into the medium. Toxicity was expressed as enzyme activity/10⁶ cells or as percent toxicity between control and the 100 µg/10⁶ cells concentration of Doerentruper quartz No. 12 (DQ₁₂).

RESULTS

The following results were obtained from the in vitro tests:

- The toxicity of DQ₁₂ is reduced by acetone, but is slightly increased by HCl and NaOH (Table II).
- Treatment with HCl and NaOH causes a sharp increase in the toxicity of the Gambach quartz (Table III).
- The toxicity of the Gambach quartz and DQ₁₂ after chemical treatment was changed by the addition of small quantities of fetal calf serum (Table IV): The toxicity of HCl-treated Gambach quartz cannot be inhibited by 0.1% of fetal calf serum (FKS), as is the case for the untreated dust.¹⁰

The toxicity of acetone-treated DQ₁₂, on the other hand, can be slightly inhibited by FKS (Table IV).

- Tables V and VI show the LDH release after incubation with treated and untreated mine dusts:
- For the 3 dusts from Group A, an increase in toxicity is to be observed after the various types of treatment: The toxicity of mine dust U 120 is particularly increased by treatment with acetone, dust V 521 by treatment with H₂O₂ and with acetone, H 520 by treatment with HCl and particularly by treatment with NaOH.
- In Group B, only the acetone treatment caused an increase in the toxicity of mine dust Y 320, whilst the H₂O₂ treatment resulted in an increase in the toxicity of dust T 124.

Analysis of the change in toxicity after chemical treatment

Table I
Characterization of the Tested Mine Dusts

Group	Dust	QTA/LKA	100-TTC-RA	pO ₂	Quartz (%)
high-rank:					
A	U 120	14,16	36,0	0,240	7,3
A	V 521	--	37,5	0,229	7,5
A	H 520	8,68	29,0	0,200	1,0
low-rank:					
B	Y 320	0,87	41,0	0,268	7,5
B	N 220	0,62	54,5	0,348	9,3
B	T 122	0,60	40,0	0,200	2,8

Control dusts: Corundum, DQ₁₂, Gambach quartz

Table II
LDH-Release (mU/10⁶ Cells) of Guinea Pig—Lung Macrophages 20 Hours After Exposure with Untreated and Pretreated Doerentruper Quartz

DQ ₁₂	µg/10 ⁶ cells		
	25	50	100
1 untreated	31	68	87
2 H ₂ O ₂ (30%)	22	40	67
3 Aceton	16	23	65
4 HCl 5 n	43	77	85
5 NaOH 5 n	56	81	87
6 RBS 5%	31	59	85
7 Aqua bidest.	47	72	94

Table III
LDH-Release of Guinea Pig—Lung Macrophages 20 Hours After Exposure with Pretreated Gambach Quartz in Percent Toxicity (100 µg Corundum/10⁶ Cells = 0%; 100µ DQ₁₂/10⁶ Cells = 100% Toxicity)

Gambach quartz	µg/10 ⁶ cells		
	100,0	200,0	300,0
1 untreated	14,1	53,5	80,3
2 H ₂ O ₂ (30%)	14,1	54,9	83,1
3 Aceton	11,3	57,7	90,1
4 HCl 5 n	85,9	87,3	100,0
5 NaOH 5 n	100,0	100,0	100,0
6 RBS 5%	21,5	57,7	77,5
7 Aqua bidest.	15,5	47,9	77,5

Table IV

Influence of Fetal Calf Serum (FKS) on the Cytotoxicity of Untreated and Treated Gambach Quartz and DQ₁₂ in the Guinea Pig—Lung Macrophages Culture Measured by the LDH-Release (mU/ml)

	without Serum	+ 0,1% FKS
Gambach quartz		
200 µg/10 ⁶ cells		
1 untreated	69	29
2 H ₂ O ₂ (30%)	82	40
3 Acetone	45	20
4 HCl 5 n	114	112
5 NaOH 5 n	-	-
6 RBS 5 %	63	38
7 Aqua bidest.	64	27

DQ₁₂

100 µg/10 ⁶ cells		
1 untreated	138	136
3 Acetone	89	36

Corundum 1 untreated

100 µg/10 ⁶ cells	21	20
200 µg/10 ⁶ cells	32	30

of mine dust N 220 is difficult. At a dust concentration of 100 µg/10⁶ cells, the cytotoxicity drops after treatment with HCl, RBS and double distilled water. This effect can no longer be observed, however, with higher dust concentrations.

DISCUSSION

The chemical and thermal treatments resulted in a change in the toxicity of a number of the mine dusts, and generally towards an increase in toxicity; in view of the altered dust surfaces, however, these changes do not permit a direct assessment of the membrane toxicity. It can be assumed that the dust surfaces are altered in such a way by the treatment with the organic and inorganic compounds, either by the leaching out of surface constituents or by absorption, that it is very difficult to draw conclusions with regard to the original dust, even if the cytotoxicity is increased as a result. The treatment can result in the removal of impurities from the dust surface; with quartz, the treatment can also result in a change in the basic crystal structure, and therefore in the electron structure. A notable feature is that in Table I, the mine dusts from Group A differ more widely than those of Group B with regard to their quartz-typical deposition areas in the lymph node test than the quartz contents of the dusts. During the in vitro test, this difference is not apparent in the untreated dusts. Only the chemical and thermal treatment of the dust surfaces caused an increase in the toxicity in the mine dusts from Group A, but less so for the dusts from Group B. Since the quartz contents of the dusts in the

Table V

Influence of the Chemical-Thermal Treatment
Group A: Reaction in Animal—High;
Cytotoxicity —Low
LDH Release of Guinea Pig—Lung Macrophages 20 Hours
After Dust-Exposure in Percent Toxicity
(Corundum = 0%; DQ₁₂ = 100% Toxicity)

		100	200	300		
		µg/10 ⁶ cells				
Corundum		0	0	0		
DQ ₁₂		100	100	100		
U 120	- 1	26	53	73	untreated	
	- 2	22	58	77	H ₂ O ₂	30%
	- 3	33	89	105	Acetone	100%
	- 4	32	76	80	HCl	5 n
	- 5	38	68	80	NaOH	5 n
	- 6	21	58	65	RBS	5%
	- 7	16	51	73	Aqua bidest.	
V 521	- 1	23	47	73	untreated	
	- 2	36	82	87	H ₂ O ₂	30%
	- 3	34	76	90	Acetone	100%
	- 4	22	50	68	HCl	5 n
	- 5	18	43	62	NaOH	5 n
	- 6	17	43	58	RBS	5%
	- 7	20	36	45	Aqua bidest.	
H 520	- 1	11	17	30	untreated	
	- 2	9	11	33	H ₂ O ₂	30%
	- 3	6	15	42	Acetone	100%
	- 4	13	35	57	HCl	5 n
	- 5	41	89	105	NaOH	5 n
	- 6	7	3	5	RBS	5%
	- 7	8	22	40	Aqua bidest.	

two groups are less than 10% and differ widely from one another in only two cases, other factors must be responsible for these differences in the size of the quartz-typical dust deposition areas in the lymph node test and in the level of the toxicity. In the lymph node test, a shift in the mean particle size of the quartz content could play a role, since the filtering of the dust particles in the lymphatic system results in a trend to smaller particle sizes and higher toxicities. More likely, however, is that the reactions and toxicities depend on the rank of the dusts from the Saar and Ruhr coalfields. An interesting fact is that the mine dusts in Group A originated from high-rank seams, whilst those in Group B originated from low-rank seams, i.e., from younger seams.

Conclusion correlates with the investigations into the specific noxiousness of the respirable dusts from the Ruhr coalfields

Table VI

Influence of the Chemical-Thermal Treatment
Group B: Reaction in Animal—Lower;
Cytotoxicity —Similar or Higher than in
Group A
LDH Release of Guinea Pig—Lung Macrophages 20 Hours
After Dust-Exposure in Percent Toxicity
(Corundum = 0%; DQ₁₂ = 100% Toxicity)

		100	200	300		
		µg/10 ⁶ cells				
Corundum		0	0	0		
DQ ₁₂		100	100	100		
Y 320	- 1	23	46	74	untreated	
	- 2	45	74	65	H ₂ O ₂	30%
	- 3	63	84	84	Acetone	100%
	- 4	36	73	79	HCl	5 n
	- 5	40	73	85	NaOH	5 n
	- 6	29	80	80	RBS	5%
	- 7	35	69	76	Aqua bidest.	
N 220	- 1	42	91	89	untreated	
	- 2	69	92	92	H ₂ O ₂	30%
	- 3	63	83	81	Acetone	100%
	- 4	22	77	82	HCl	5 n
	- 5	55	89	88	NaOH	5 n
	- 6	18	62	67	RBS	5%
	- 7	22	72	81	Aqua bidest.	
H 520	- 1	14	42	56	untreated	
	- 2	48	75	79	H ₂ O ₂	30%
	- 3	20	63	72	Acetone	100%
	- 4	15	48	56	HCl	5 n
	- 5	15	52	67	NaOH	5 n
	- 6	11	28	47	RBS	5%
	- 7	46	46	56	Aqua bidest.	

by Reisner and Robock,¹⁶ Robock et al.¹² and the more recent studies by us¹⁷ which revealed that for dusts originating from different collieries and different stratigraphic horizons but with comparable mineral content, the cytotoxicity increases with the age and rank of the seams.

REFERENCES

1. Beck, E. G.: Die Reaktion in vitro gezüchteter Zellen auf partikelförmige Verunreinigungen und hochpolymere Stoffe. *Forschungsbericht NRW* No. 2083:1-125, Westdeutscher Verlag Cologne and Opladen (1970).
2. Beck, E. G., Manojlovic, N.: Untersuchungen über die Wirkung von Grubenstäuben auf in vitro gezüchtete Alveolarmakrophagen vom Meerschweinchen. *Silikosebericht Nordrhein-Westfalen* 8:125-129, Verlag Glückauf Essen (1971).
3. Christian, R. T., Nelson, J.: Coal: Response of cultured mammalian

- cells corresponds to the prevalence of coal workers pneumoconiosis. *Environ. Research* 15:232-241 (1978).
4. Laufhütte, D. W., Robock, K., Klosterkötter, W.: Untersuchungen über die zytotoxische Wirkung von Grubenstäuben aus dem Saarkarbon. *Ergebn. Unters. Geb. Staub—Silikosebekämpfung. Steinkohlenbergbau* 8:131-138 (1971).
 5. Seemayer, N. H., Manojlovic, N., de Ruiter, N.: Untersuchungen über die biologische Wirkung von Grubenstäuben. I. Zytoxische Wirkung von Grubenstäuben auf alveolare Makrophagen des Meerschweinchens in vitro. *Silikosebericht Nordrhein-Westfalen* 11:153-157, Verlag Glückauf Essen (1977).
 6. Seemayer, N. H., Manojlovic, N.: Untersuchungen über die biologische Wirkung von Grubenstäuben. II. Vergleichende Prüfung der Zytotoxizität von 16 verschiedenen Grubenstäuben an alveolaren Makrophagen des Meerschweinchens in vitro. *Silikosebericht Nordrhein-Westfalen* 12:173-179, Verlag Glückauf Essen (1979).
 7. Seemayer, N. H., Manojlovic, N.: Untersuchungen zur spezifischen Schädlichkeit von Feinstäuben des Steinkohlenbergbaus. VI. Vergleich der Zelltoxizität von 20 Grubenstäuben an alveolaren Makrophagen des Meerschweinchens in vitro. *Silikosebericht Nordrhein-Westfalen* 13:225-232, Verlag Glückauf Essen (1981).
 8. Schlipkötter, H. W., Seemayer, N. H., Manojlovic, N.: Protektiver Effekt von Kohlestaub gegenüber der zytotoxischen Wirkung von Quarz in Makrophagenkulturen des Meerschweinchens. *Beitr. Silikose-Forsch.* 28:31-39, (1976).
 9. Tilkes, F., Beck, E. G.: Macrophage function after exposure to non-fibrous mineral dusts. Second International Workshop on the in vitro effects of mineral dusts. *Environment Health Perspectives* 51: 167-171 (1983).
 10. Tilkes, F., Beck, E. G.: Einfluß von Kulturbedingungen auf die Zytotoxizität von Mineral- und Grubenstäuben. VI. *Internationale Pneumokoniose-Konferenz* (1983).
 11. Seemayer, N. H., Braumann, A.: Untersuchungen über die zytotoxische Wirkung von Quarz- und Grubenstäuben auf menschliche Makrophagen in vitro. *Silikosebericht Nordrhein-Westfalen* 15:301-312, Verlag Glückauf Essen (1985).
 12. Robock, K., Bruch, J., Reisner, M. T. R.: Untersuchungen zur spezifischen Schädlichkeit von Feinstäuben des Steinkohlenbergbaus: V. Ergebnisse von Zelluntersuchungen nach TTC- und pO₂-Methode. *Silikosebericht Nordrhein-Westfalen* 13:217-223. Verlag Glückauf Essen (1981).
 13. Kriegseis, W., Scharmann, A., Serafin, J., Beck, E. G., Tilkes, F., Bruch, J.: Die Abhängigkeit der Zytotoxizität SiO₂-haltiger Stäube von ihrer Oberflächenreinheit. *Silikosebericht Nordrhein-Westfalen* 14:281-299, Verlag Glückauf Essen (1983).
 14. Hilscher, W., Parov, E., Grover, R., Molik, B.: Untersuchungen zur spezifischen Schädlichkeit von Feinstäuben des Steinkohlenbergbaus: XI. Erfassung der Fibrogenität von 50 grubenechten Feinstäuben mit dem quantitativen Lymphknotentest. *Silikosebericht Nordrhein-Westfalen* 13:265-270, Verlag Glückauf Essen (1981).
 15. Robock, K.: Die Wirkung mechanischer, thermischer und chemischer Behandlungen von Siliciumdioxid- und Asbest-Stäuben auf Zytotoxizität und Elektronenstruktur. *Beitr. Silikose-Forsch.* 26:111-262 (1974).
 16. Reisner, M. T. R., Robock, K.: Untersuchungen über die spezifische Schädlichkeit von Feinstäuben aus dem Ruhrkarbon. *Silikosebericht Nordrhein-Westfalen* 10:145-154. Verlag Glückauf Essen (1975).
 17. Tilkes, F., Beck, E. G.: Unpublished results.

QUANTIFICATION OF ANTHRACOSILICOTIC GRANULOMAS IN LUNGS AND LYMPH NODES OF RATS

J. BRUCH • B. Hilscher • W. Hilscher

Medical Institute of Environmental Hygiene, Düsseldorf, Institute for Occupational Medicine
and Hygiene, Essen, Medical School, University of Essen, FRG

ABSTRACT

In the past, the extension and the degree of fibrotic reactions induced by quartz containing dusts were estimated, and the results were documented as a certain number of + + + or different degrees of fibrosis. It was in the early seventies, that our group succeeded in quantifying the dust induced nodules and their particular components.

Within the last years the hit method has been improved with the aid of semi-automatic and fully-automatic apparatuses which are able to identify histological structures and transform the data into binary signals.

One group worked as well with the Analysis System Manual ASM (Leitz), as the Inter Active Image Analysis System IBAS (Zeiss/Kontron) and the Quantimet 970 (Cambridge Instruments). By these instruments (1) the sizes of dust induced alterations and their particular components (a. dust particles, b. connective tissue) or (2) the chord lengths of reticular or collagen fibres can be measured. It is by this possible, not only to quantify larger or smaller fibrotic lesions and their particular components in the different organs (lungs and lymph nodes) but also—in optimizing the method of BELT & KING (1945): the degree of fibrosis.

No Paper provided.

RESPIRATORY MORBIDITY IN AGATE WORKERS

S.H. CLERK

Gandhi Labour Institute, Ahmedabad, India

ABSTRACT

342 agate workers in a household industry in Khambhat were studied along with 149 controls. Ornamental and decorative items are made from agate stones. Processing of agate stones is by heat treatment, chipping, grinding, drilling and polishing processes. Prevalence of all lung diseases was 63.4% in workers and 35.6% in controls. Percentage of pneumoconiosis, pulmonary tuberculosis, chronic bronchitis, bronchial asthma, and tropical eosinophilia was 18.4, 15.5, 2.6, 7.3, and 3.2 respectively in agate workers. Agate dust seems to be precipitating pneumoconiosis and asthma. Pneumoconiosis was the same in both sexes, although tuberculosis was higher in female workers. 50% of pneumoconiosis cases had no symptoms. Age groups 20, 21-30, and 31+ showed an increasing trend in prevalence of all lung diseases, as compared to controls. Pneumoconiosis is increased with increase in dust exposure. Exposure to dust for as little as 2 years precipitated pneumoconiosis of category 'p'. Pneumoconiosis was 22.1% in grinders and 8.3% in chippers. Mean age of categories pqr, stu, and ABC was 26.7, 30.2, and 34.1 years respectively. In child workers, both pneumoconiosis and tuberculosis were 14.3 percent. Lowest age detected in pneumoconiosis cases was 11 years. Healthy grinders showed lower lung function values than healthy chippers. These values had decreased in all categories. Dust concentration in grinding was more than in chipping process. Free silica was 83% in respirable dust.

No Paper provided.

**AIR POLLUTION INVESTIGATIONS IN SOME PLANTS FOR PRELIMINARY
PROCESSING OF VEGETABLE FIBRES (COTTON AND HEMP)
—AIRBORNE DUST AND MYCOTOXICOLOGICAL CONTAMINATION**

ST. IVANOVA-DJOUBRILOVA • M. Dimitrov • E. Drenska • M. Nikolcheva

Institute of Hygiene and Occupational Health, Sofia, Bulgaria

ABSTRACT

The preliminary processing of vegetable fibres generates considerable dust concentrations in the working environment. The dust pollution in two plants for cotton and hemp processing was investigated. For all technological processes used, the time-weighted-average dust concentrations and the mycotoxicological pollution were determined. It was found that the dust concentrations are above the adopted standards for occupational exposure limits and that a high degree of contamination with spores of microscopic fungi (*Cladosporium*, *Alternaria*, *Aspergillus*, *Penicilium*, *Fusarium*) exists.

The proved mycotoxic and allergenic effects of this mycoflora in combination with the high airborne dust concentrations are prerequisite, imposing a reassessment of the approaches for evaluation of the occupational hazard, an action of great importance for the prophylaxis of a significant contingent of workers.

No Paper provided.

IMPAIRMENTS IN FUNCTIONAL SUBSETS OF T-SUPPRESSOR (CD8) LYMPHOCYTES, MONOCYTES, AND NATURAL KILLER CELLS AMONG ASBESTOS-EXPOSED WORKERS

J.G. BEKESI • F.N. Chu • P. Tsang • A. Fischbein

Mount Sinai School of Medicine, New York, NY, USA

ABSTRACT

Asbestos exposure has been shown to be associated with a variety of aberrations in both cell-mediated and humoral immunity.

In order to clarify cellular immunological mechanisms of asbestos associated effects functional and developmental stages of lymphocyte subsets were studied in a group of 70 workers with a high prevalence of asbestos related chest radiographic abnormalities.

An increase in the number of T suppressor cells was closely associated with a decrease in T lymphocyte functions while numerical defects in activated monocytes (Leu M3 Ia) and natural killer cells (Leu 7) were correlated with a depressed Th/Ts ratio. Furthermore, among asbestos-exposed workers with depressed T cell functions we have demonstrated a significantly higher number of the effector Ts (Leu 2 Leu 8) subset which regulates both the Th/Ts lymphocyte system as well as B cells and NK cell activities.

The findings suggest one mechanism for the association between asbestos exposure and immune dysfunction.

Changes in the T suppressor feedback regulatory loop were identified causing this immunoregulatory imbalance.

No Paper provided.

ON THE USE OF LIGHT MICROSCOPY FOR THE RECOGNITION, EVALUATION AND CONTROL OF RESPIRATORY DISEASE

J. JANKOVIC • W. Jones

National Institute for Occupational Safety and Health, Division of Respiratory Disease Studies
Morgantown, West Virginia, USA

ABSTRACT

Over the years in our laboratory light microscopy has been a valuable tool for the recognition, evaluation, and control of a variety of respiratory hazards. In this presentation we will review some common uses as well as describe a few new applications.

In the area of recognition we will describe two case studies in which petrographic applications of light microscopy were utilized to identify possible etiologic agents responsible for specific respiratory ailments. Under the area of evaluation we will describe how the microscope is used for identification and quantification of components in bulk and air samples. Examples will include both asbestos as well as the lesser known technique of focal screening for the estimation of % silica in various matrices. In the area of control we will describe a method in which the microscope can be used for identification of trace amounts of airborne colored chalk dust for the purpose of evaluation of the overall performance of a ventilation system.

Although widely neglected in this age of high technology, the simple light microscope remains a highly utilitarian device in the practice of the craft of industrial hygiene. We hope that this presentation will serve to promote its use.

No Paper provided.

DESIGN AND CALIBRATION OF A MULTI-PURPOSE AEROSOL SAMPLER

W. JONES • N. Esmen • D. Weyel

University of Pittsburgh Graduate School of Public Health, Pittsburgh, PA

ABSTRACT

A new aerosol sampler suitable for a variety of industrial hygiene sampling applications has been designed, built, and evaluated. A distinctive feature of the design is the use of impactor stage modules that can be used separately for various single-stage applications or in combination for multi-stage uses. The sampling modules are of two principal types: "standard curve" and "matched curve." The standard curve modules were designed to provide sharp cut points over a range of particle size from 1–20 μm . The matched curve modules were designed to conform to the aerosol mass fractions recently defined by the ACGIH.

When used for multi-stage sampling the modules can be arranged in both the series and parallel configurations. One particular parallel arrangement allows for the simultaneous measurement of respirable, thoracic, and inspirable mass. The sampler is small, light, and compact, making it well suited for personal sampling in each of its configurations. It was also designed to accept a variety of collection media, allowing for gravimetric, chemical, and microscopic analysis of collected dust. Additionally, a calibration chamber was designed and built and a calibration technique featuring sonic dust generation and microprojection analysis was successfully employed.

No Paper provided.

COMPUTERIZED TOMOGRAPHY (CT) IN COAL WORKERS' PNEUMOCONIOSIS

PAN JISHU* • Wang Shuhua† • Zheng Zhongmin†

*Institute on Occupational Medicine of Ministry of Coal Industry, Beijing, China

†General Hospital of Kai Lan Coal Mine Bureau, Tangshan, China

CWP is a common occupational disease and there have been many publications on the use of X-ray examination in this condition. But we have been unable to trace any publication on CT diagnosis of CWP. In order to investigate the diagnostic value of CT for CWP, 100 coal workers were examined by CT scanning and results compared with that of standard chest radiographs and pulmonary function tests.

SUBJECTS AND METHODS

The 100 male underground coal workers were selected at random. The age range was 40 to 75 years (mean 62) and coal dust exposure range was from 11 to 40 years (mean 20.15).

CT Scanning Examination

CT scans were obtained using a Toshiba TCT80A scanner at 1 cm intervals from the apex to the diaphragm at full inspiration appropriate for the lung (level -800, width 1000 HU) and mediastinum (level 40, width 400 HU).

Visual analysis

1. *Small opacity.* According to the principle of ILO Classification, the profusion of small opacities on each slice of CT was classified into four categories. A scoring system for the CT scans was devised. The two lungs were divided into six zones and CT score for small opacities for any zone was counted as the product of profusion of small opacities and the percentage ratio of the small opacity slices to whole slices on that zone. Then the scores of the left, right and two lungs might be counted. The starting point for diagnosing pneumoconiosis was considered to be the score '2' i.e., at least two lung zones were full of small opacities with category 1.
2. *Large opacity.* If a dense opacity with a diameter than 10 mm appeared in the lung fields of two adjacent slices, and was still observed at the mediastinum level then a large opacity was recorded.
3. *Emphysema.* Following Goddard's standard we considered areas of low attenuation and vascular disruption to be suggestive of emphysema. The emphysema was classified into four grades according to its extent on the CT films.¹ The scoring system for CT emphysema was counted as the product of the emphysema grade and percentage ratio of emphysema slices appear-

ing to the whole slices on that zone. Emphysema might be diagnosed if there were characteristic appearances of emphysema on at least half slices on one lung zone.

Numerical analysis

The mean attenuation of the whole lung field density was measured at the three slices of the apex of the lung, carina and immediately above the dome of the right hemidiaphragm corresponding to the upper, middle and lower zones of the right lung for every subject. The mean attenuation values of the above three slices was also calculated.

X-ray Examination

Standard PA and lateral chest X-ray films were obtained on all subjects at the same time as CT scanning was carried out. The films were read using the 1980 ILO Classification and also according to the routine standard² did the diagnosis of emphysema.

Pulmonary Function Tests

The following tests were carried out for 80 subjects while having CT examination: VC%, FEV₁%, FEV₁/VC%, MBC%, RV/TLC. Loss of lung function was considered to be present if the FEV₁% was less than 60, FEV₁/VC% less than 60, MBC% less than 80 and RV/TLC more than 40%.

RESULTS

Visual Analysis

2175 slices of CT scanning were taken from 100 coal workers. Three had no small or large opacities present. 45 had small opacities present. Of these 34 might be diagnosed as simple pneumoconiosis with the CT score 2. 42 had complicated pneumoconiosis with large opacities present. 96 had changes with emphysema. Of these 87 could be diagnosed as having emphysema according to the CT criterion given above.

Small opacity

995 slices of scanning were taken from 48 subjects without large opacities. At any zone category 1 profusion was the most common (69.14%). Category 3 profusion was the least common (2.97%). Among the 497 slices showing small opacities were observed, mostly in the middle and lower zones. For the distribution of small opacities at anterior or posterior parts of the lung small opacities were observed at

the posterior part of the lung for 459 slices (92.35%) and at the anterior part of the lung for 324 slices (65.19%).

Large opacity

There were large opacities present on CT for 52 subjects. 88.3% of large opacities appeared at the posterior part of the lung. Only 11.7% at the anterior part of the lung. 84.1% of large opacities were mainly distributed at the medulla of the lung with a distance of 1–2 cm from the outer margin of lung amongst large small opacities distributed obviously at the medulla of the lung.

Emphysema

For all scanning slices 932 (42.38%) of the right lung, and 972 (40.09%) for the left lung showed appearances characteristic of emphysema. Emphysema appeared mostly in the lower lung zones (65.8%) and least at the upper zone (19.4%). Grade 1 was the most common (23.84%) with grade 4 accounting for only 0.54%. For most CT films (96.57%) emphysema was observed at the anterior part of the lung. 34 bullae were observed in 14 subjects. Most of the bullae were located in the upper lung zone and in the posterior part of the lung.

Numerical Analysis

The mean attenuation value of lungs for 48 subjects, without large opacities, was -854.95 ± 47.92 HU. That for the upper, middle and lower zones were -846.49 ± 60.62 , -871.7 ± 48.97 and -846.6 ± 49.33 HU respectively. No definite trends were discoverable. These values were calculated statistically for 0, ≤ 2 and > 2 of the CT score for the profusion of small opacities and were -874.43 ± 45.11 , -855.27 ± 34.45 and -856.11 ± 48.44 HU respectively. Again no definite rule was found. The mean attenuation value for the upper, middle and lower zones for the 100 coal workers were -839.43 ± 63.14 , -857.47 ± 48.31 and -860.36 ± 47.79 HU respectively, all lower than the normal value. The mean value of the sum of attenuation values of three slices of the right lung for all subjects calculated statistically for ≤ 3 and > 3 of CT score for emphysema were -849 ± 44.09 and -863.9 ± 39.73 HU respectively. There was a significant difference between the attenuation values of ≤ 3 score and > 3 score ($t = 2.18$, $P < 0.005$).

Comparison of CT and Chest Radiograph

Small opacity

For diagnosing pneumoconiosis either positively or negatively by CT and ILO Classification 41 subjects (85.4%) were agreed, 7 (14.6%) were not. This was within the acceptable extent of the difference of film examination. CT score for small opacities was also closely related to the complete twelve-point scale of profusion of the ILO Classification 1980 ($r = 0.7357$, $P < 0.01$).

Large opacity

For 52 subjects with CT showing large opacities, large opacities could be diagnosed on chest radiographs for 37. None of the subjects showed a large opacity on his chest radiograph, but not on CT. Thus the detectable rate of large opacity with CT was increased by 15% over that by chest

radiography. For 30 subjects diagnosed as simple pneumoconiosis by their chest radiographs, according to the ILO Classification 1980, 12 (40%) had large opacities in their CT. CT was also to demonstrate calcification and cavitation in large opacities much more readily than chest radiography. For 52 subjects showing large opacity 28 of them (53.9%) had calcification on CT examination, with the mediastinum window level, but only 2 (5.4%) had calcification areas on chest radiograph. 18 (34.62%) of the subjects showed cavitation on CT but only 2 subjects showed cavitation on chest radiography.

Emphysema

Emphysema was diagnosed for 87 subjects by CT but only for 49 subjects by chest radiography. There were very significant difference between these two methods ($u = 5.8$, $P < 0.001$). The use of CT increased the rate of detection of emphysema by 38%. Bullae were shown by CT for 14 subjects but on chest radiography only 4 of them had typical bullae.

Comparison of CT and Pulmonary Tests

CT score for small opacities was not definitely related to lung function. The comparison of CT score of emphysema and the number of lung function tests showing decrements demonstrated: For 60 subjects with a score of ≤ 6 the mean number of positive items was 2.65. For 20 subjects with a score of > 6 the mean number of positive items was 3.75. There was a very significant difference between the two cases ($t = 2.77$, $P < 0.01$).

DISCUSSION

Using standard radiography pneumoconiosis could be diagnosed with confidence by X-ray, and the ILO Classification was the generally accepted "gold standard" for the categorization of pneumoconiosis. In this paper it has been shown that there was an equal ability to diagnose simple pneumoconiosis using CT. The CT score of small opacities designed by us was very closely related to the ILO Classification and showed that CT might be used to diagnose pneumoconiosis reliably on chest radiographs. Although CT was better than chest radiography in detecting small opacities distributed at the anterior/posterior context or medulla part of the lung the additional cost involved in using CT did not justify the slightly superior advantage over chest radiography for diagnosing simple pneumoconiosis.

CT was significantly superior to the chest radiograph for diagnosing complicated pneumoconiosis. In this paper it has been shown that 15% more large opacity might be detected by CT than by chest radiography. It has been shown that in films showing simple pneumoconiosis by chest radiography large opacities could also be detected by CT for 40% of them. In addition it has been shown that CT is capable of detecting emphysema much more easily than chest radiography, and that the detection rate for emphysema is 38% greater for CT than chest radiography. It is common knowledge that the large opacity and emphysema were the important causes of deteriorating for patients of pneumoconiosis. Thus it was important to detect large opacities and emphysema early. In our opinion the main in-

dication for CT in coal workers is to detect these large opacities and emphysema undetectable by chest radiographs.

In recent years there has been a great deal of interest in diagnosing diffuse disease and emphysema of the lung by use of CT attenuation values.^{1,3} Rosenblum reported that the mean attenuation value for whole lung for normal persons was -743 ± 58 HU.³ Attenuation of the 100 coal workers described in this paper was lower than the above mentioned normal value and tended to decrease with increase of the CT score for emphysema. This appeared to be related to the fact that most of the coal workers had emphysema. Diagnosis of emphysema by measuring the attenuation value of lung was possible. On the other hand the attenuation value of lung had no definite relation to the CT score for small opacities. In our opinion this might be the result of mutual influence between pneumoconiosis with differing degrees of profusion

and emphysema with varying degrees of severity. In the situation where there might be simultaneous co-existence of disease with decreasing and increasing density of lung, as is shown by the coal workers in this paper, precisely how to evaluate the mean attenuation values of lung measured also needs further study. For this reason we do not, at present, recommend diagnosing pneumoconiosis by measuring the attenuation value of lung. This is best done mainly by visual analysis.

REFERENCES

1. Goddard, P.R., et al: Computed tomography in pulmonary emphysema. *Clin. Radiol.* 33:379-387 (1982).
2. *Diagnostic Radiology*, Vol. 1, pp. 235-237, R.G.Grainger and D.J. Allison, Eds. Churchill Livingstone, New York (1986).
3. Rosenblum, L.J., et al: Density patterns in the normal lung as determined by computed tomography. *Radiology.* 138:409-416 (1980).

EXPERIENCIA EN EL USO DE LA CLASIFICACIÓN INTERNACIONAL DE NEUMOCONIOSIS OIT (1980) EN 40 CENTROS MINEROS DEL PERÚ

FRANCISCO K. TUKIUDA

Instituto de Investigaciones de Enfermedades Profesionales Mineras (Inveppomi)

Walter Varillas V. Instituto de Salud y Trabajo (ISAT) Lima-Perú

ABSTRACT

Se efectuaron más de 12,000 Radiografías de Tórax de trabajadores mineros entre 1984-1988 (Febrero) de acuerdo a las recomendaciones técnicas OIT (1980) esto es: Equipo Rayos X (Condensadora de descarga), procesadora automática y pantallas intensificadoras de imagen Los Centros Mineros se situaban a diferentes altitudes sobre el nivel del mar, correspondiendo la mayoría (80%) a trabajadores que laboran entre 3,500-5,000 m.s.n.m.

Dentro de los hallazgos radiológicos, se observaron anomalías en cerca del 50% de los examinados. Hemos encontrado dificultades en la utilización de la Clasificación OIT. sobre todo en los trabajadores de altura. Se ha tratado de diferenciar las placas de los trabajadores expuestos y no expuestos a diferentes altitudes, evidenciando dibujo pulmonar diferente. El 20% de los examinados presentaron Neumoconiosis (Igualmente el 20% de los mismos, presentaban asociación a TBC.).

Creemos necesario adoptar ciertas características en el patrón radiológico, sobre todo, en los mineros de altura.

Los resultados de Función Respiratoria (Flow-Volume) presentó muchas variaciones con respecto a los fenómenos restrictivos tradicionales. En este sentido requerimos nueva evaluación y probable reformulación de los parámetros utilizados.

Creemos igualmente que los altos índices de Policitemia juega papel muy importante en los resultados obtenidos, siendo indispensable nuevas evaluaciones fisiológicas, anatomopatológicas que nos permitan esclarecer nuestros hallazgos.

No Paper provided.

INORGANIC PARTICLES IN COAL MINERS' LUNGS

L.E. STETTLER • J.H. Tucker • R.D. Riley • S.F. Platek • J.P. Mastin • F.H.Y. Green

Division of Biomedical and Behavioral Science, and Division of Respiratory Disease Studies,
National Institute for Occupational Safety and Health, Cincinnati, Ohio 45226, and
Morgantown West Virginia 26505, USA

ABSTRACT

An automated scanning electron microscope-energy dispersive X-ray analysis-image analysis system was used to determine the total lung exogenous, inorganic particle concentrations for 21 coal miners. The particle data were determined from the analysis of a single, randomly selected, piece of formalin-fixed tissue from each subject. Over 28,000 individual exogenous particles from the 21 lungs were analyzed. The total exogenous particle concentration (average \pm standard deviation) for the 21 miners was $3,003 \pm 2,267$ million particles per gram of dry lung with a range of 257 to 9,991 million particles/gram. As a point of reference, the average exogenous particle concentration seen in the lung of 87 subjects from the Cincinnati, Ohio urban area who had no overt pneumoconioses was 477 ± 380 million particles/gram with a range of 71 to 1,862 million particles/gram.

In General, silica and various aluminum silicates were the major particle types found in both the coal miner and the urban lungs. The miner lung silica contents ranged from 27 to 2,484 million particles/gram with an average of 823 ± 594 million particles/gram. The average miner aluminum silicate level was $1,734 \pm 1,629$ million particles per gram with a range of 138 to 6,943 million particles per gram. The average silica and aluminum silicate contents of the Cincinnati urban lungs were 94 ± 70 and 179 ± 144 million particles/gram, respectively.

No Paper provided.

CHARACTERISTICS OF LUNG-RETAINED COAL DUSTS RELATED TO MORPHOLOGICAL AND CLINICAL FINDINGS

M. DOBREVA • T. Burilkov • K. Kolev

Institute of Hygiene and Occupational Health, Medical Academy, Sofia Bulgaria

The role of the coalrank, quartz and other mineral admixtures in the pathogenicity of coal dusts is still not sufficiently elucidated. The relationships, established for coal sorts in definite coal fields are not always confirmed in others. Some authors give priority to quartz and the other mineral admixtures as determinants of the dust fibrogenicity, but others stress the coalrank itself.^{1,3,10,14,15}

In the oldest coal field in Bulgaria—the Pernik one, in which brown coal has been extracted as long ago as since more than 100 years mainly by underground mining, clinical cases of coal dust pneumoconiosis have still not been detected up to now.² The field is set up of four strata with clay interlayers between them, situated in clay marl. The micropetrographic coal composition included mainly humanit and vitrinit—about 53–58% and mineral admixtures, mainly clay and quartz—22–43%. Since the last 20–30 years, intensive methods of extraction were introduced, which resulted in comparatively high dust concentration in the air of the mine.

The quartz content in the airborne dust was varied in a wide range, being in the total dust 7%, in average, and in the respirable fraction—4%.⁹

Taking into consideration the comparatively high dust concentrations with significant quartz content in the air of the mine, it becomes difficult to explain the absence of pneumoconiosis cases among the exposed workers.

The purpose of this investigation was to examine the quantity and composition of the lung dust of deceased exposed miners from the above mentioned coal field and to establish possible changes in their lung morphology. So we hoped to make a contribution in the elucidation of the pathogenicity of the dust from this coal field.

MATERIALS AND METHODS

A post mortem study of the morphological lung changes and the lung dust from 23 miners with continuous dust exposure (up to 30 years) in the Pernik coal field, but without clinical and radiographic data for pneumoconiosis while still living, was performed. The average life continuance of the investigated cases was from 32 to 79 years, all deaths under the age of 50 being due to labour or other accidents. The lung dust was isolated by the formamide-digestion method after Thomas and Stegemann. A constant weight of dust at 105° and the residue after ashing at 600° was determined.

The free crystalline silica content was determined by the spectrophotometric micro-method according to Polezhaev⁴

and I-R-spectrophotometry,¹¹ the total silica quantity—by the method of Peregut and Gernet.¹²

For histological evidencing of collagen the method of Holusa was applied.⁸

The integral half-quantitative assessment of dust-related morphological changes and the extent and severity of lung fibrosis, in particular, was performed by the scoring system of Kolev⁵ for the following indices: interstitial fibrosis, type and extent of granuloma, hyalinization in nodules and conglomerative masses, presence and dissemination of aseptical necrosis, etc. According to this system, the maximum score of 24—rarely up to 28, is obtained at the presence of exclusively severe fibrosis, while the scores from 1 to 7 correspond to negligible reactions of the lung parenchyma to the lung dust retained in it, without relevant collagenogenesis.

RESULTS

According to the length of the exposure, the cases under study were divided into four groups: group I—2 cases with exposure up to 10 years, group II—from 10 to 20 years and group III—from 21 to 30 years. In group IV, 4 cases with unknown length of exposure were included. The data obtained in the examination are shown in Table I.

The quantity of the isolated lung dust was varying between 0.8 and 9.1 g. For the cases of the group I it was under one g., for those of group II—2.8 g in average, for group III—3.9 g and for group IV—5.3 g.

The residue after ashing at 600°C for all investigated cases was varying from 34 to 62%, the total silica content—from 11.2 to 40.5, in average 22.6%, whereas the free crystalline silica content—from 2.9 to 10.7%, or 6.1% in average.

The absolute quantity of quartz in lungs for the two cases with comparatively short exposure period (up to 10 years) attained an average of 38.3 mg, or 22.5 mg/100 g dry tissue. For the two groups of longer exposure, significantly greater quartz quantities were found: for the group II—176.8 mg total quantity or, 110.4 mg/100g dry tissue; for group II—261.9 mg and 145.9 mg/100 g dry tissue; and group IV—404.0 mg or 140.1 mg/100 g dry tissue. At calculating the mean quantities in group II for both total lung dust and quartz, one case which was drastically different on the background of the other cases, was excluded.

Pathoanatomic Findings

In 14 of the lungs investigated macroscopic and microscopic

Table I
Characteristics of Dusts, Extracted from Coalminers Lungs, Post Mortem

Length of exposure years	Number of cases	Total quantity of dust, g average	Quartz content in dust % average	Quartz content from... to	Quartz content mg/100 g dry tissue average	Grade of morphological changes
<10	2	0,85	4,5	20,5- 25,0	22,5	3, 4
from 11 to 20	8	2,8	6,6	28,3-156,1	110,7	3, 5, 5, 4, 5, 5, 4, 6
from 21 to 30	9	4,1	6,2	34,7-314,5	145,9	3, 1, 4, 3, 3, 5, 3, 4
unknown	4	5,3	7,9	80,8-190,7	140,1	5, 5, 5

signs of bronchitis with different severity and cell-proliferation in the interalveolar septa were seen. The nonhomogeneity of the distribution of the changes in both lungs as well as the involvement of the pleura with dust accumulations under it, should be noted. The dust was situated peribronchially, perivascularly and septally, only few dust granuloma being seen. No enlargement and confluence of lymph nodes was observed, in spite of the significant quantity of centrally situated dust, found both in macrophages and extracellularly—in an irregular net of collagen fibers.

According to the accepted scale for integral assessment of the dust-related morphological changes the cases were given estimates from 1 to 5 (with the exception of one i.e., in general the changes were assessed as poor.

Clinical data

While still living, neither of the cases was found to be carrier of dust-related disease. In three of them, after being pensioned off, severe bronchitis with respiratory and cardiac insufficiency were established.

The cases under 50 y. died on occupational or other accidents and the rest of the cases—on different nonoccupational diseases, mainly of the cardiovascular sphere.

DISCUSSION

The data obtained in the present study showed great individual differences in the lung dust quantity for miners with approximately the same exposure—a finding, reported also by other authors.

The dust quantity and its ashed content, as well as the quartz content found in the lungs we investigated, was significantly lesser as compared with that found by other authors in the lungs of coal miners with manifested fibrosis changes.^(1,6,7,13) This fact could be explained by the lower dust concentrations in the mines of the Pernik coal field, or to the lesser aggressiveness of the dust, leading most probably to a better clearance.

In support of the last explanation comes the fact that the difference in the lung dust quantity, accumulated in the groups of subjects with 10–20 and 20–30 year exposure were comparatively small—a little more than 1g of dust. On the other hand, in 10 of the cases the quartz quantity per 100g dry tissue exceeded that established by Einbrodt and Klosterkötter⁶ and confirmed by other authors^{5,7} critical level—150 mg, at residence time more than 30 years.

The clinical pathological data showed that the exposure to brown coal dust in the Pernik coal field, regardless of its continuance, did not lead to significant changes of fibrosis nature. The comparatively frequent morphological findings in the bronchial tree have no clinical correlate or are diagnosed as simple, non-obstructive dust-related bronchitis.

The score system we used for assessment of dust-related changes in the lungs allows a semi-quantitative categorization of the findings with good recurrence. The values obtained were between 3 and 5. Nevertheless, this study showed that when used for estimation of the reaction to non-fibrogenic dusts it is necessary for indices concerning the condition of the bronchial tree to be added. The lung changes in the cases we studied differ and are more favourable than the described in literature "simple pneumoconiosis" in coal miners in FRG, Great Britain, France and USA. On the other hand, the dust quantity does not exceed that, corresponding to the 0 criterion in the coal fields mentioned above.^{5,6,13} etc. That's why, our hypothesis that the dust from the Pernik coal field is less harmful as compared with similar sorts of coal dust from other coal fields should be confirmed by further experiments.

REFERENCES

1. Benett, J.G., Dick, J.A., Kaplan, Y.S., Shand, P.A., Sheman, D.H., Thomas, D.J., Washington, J.S.: The Relationship between Coal Rank and the Prevalence of Pneumoconiosis. *Brit. J. of Ind. Med.* 36:206-210 (1979).
2. Bourilkov, T., Dobrova, M., Ivanova-Djoubriilova, S.: *Mineralni prahove v rabotnata sreda*. pp. 124-140. Medizina i Fizikultura. Sofia (1983).
3. Casswell, C., Bergman, I., Rossiater, C.E.: The Relation of Radiological

- Appearance in Simple Pneumoconiosis of Coal Workers to the Content and Composition of the Lung. *Inhaled Particles and Vapours*, III.2, pp. 713-726. W.H. Walton. Old Woking, Unwin Bros. (1971).
4. Dobreva, M.: Chemical Micromethod for Quantitative Determination of Free Crystalline Silica in Finely Dispersed Industrial Dusts. *Ann. Occup. Hyg.* 18:121-127 (1975).
 5. Dobreva, M., Bourilkov, T., Kolev, K., Lalova, P., Ivanova, S., Tcherneva, P., Dancheva, N.: Zavisimost meju minerologicnata i fizikohimicna karakteristika na belodrobnite prahove i tjahnata fibrogenost. *Savmesten Simposium po Vaprosite za borba s praha i belodrobnii zaboljavanija porodeni ot nego*. Drujestvo za higijena—NRB, Drujestvo za higijena i ohrana na truda—GDR, Vidin. Bulgaria (26.-27.09.1981).
 6. Einbrodt, H.J., Klosterkötter, W.: The Free SiO₂ Content of Dust Isolated from Lungs as Measure for Silicosis in Man. *Ergebnisse von Untersuchungen auf dem Gebiet der Staub- und Silikosebekämpfung im Steinkohlenbergbau*. 5:97-99. Verlag Glückauf. Essen. (1965).
 7. Holusal, P., Shkoda, V., Havranpva, I.: Soderzhanie pyli, eyo mineral 'nyi sostov i kvarz v lyogkih u raznyh patomorfologicheskikh form uglekop-skogo pneumokoniosa—redvaritel' noe soobstvenie. *Metodi Analiza i Ocenka Vozdeistviya fibrogennyh pylei*. pp. 117-128. SEV. Postoyannaja Komissia po Sotrudnicestvu v Oblasti zdravoohraneniya. Moskva (1987).
 8. Ivanova, S.: Sastojanie na prahovija faktor v nijakoi vaglistni rudnizi u nas. *Mejdunaroden Simposium po Borba s Praha i Prahovite Zaboljavanija*. MNZ, Sliven, Bilgaria.(30.05=01.06,1986).
 9. Holusa, R. *Stain Technol.* 38.:204-205 (1963).
 10. Le Bouffant, L.: Etude de la Nociyite' des Poussieres de Mines de Charbon en Fonction de leur Caracteristiques Physiques et Mineralogiques. Relations avec les Donnees Epidemiologiques. *VI Int. Pneumoconiosis Conference*. 1985. pp. 124-132. Bergbau- Berufsgenossenschaft—ILO, Bochum, FRG (20-23 September 1983).
 11. Lukanova, R.T.: *Prilozhenie na IR-Spectrofotometrijata za kolicestveno Opredeljane na Quartz i Amorfen Svoboden SO₂ v Promisleni Prahove*. Disertacija. Med.Academija. Sofija (1978).
 12. Peregud, E., Gernet, E.: *Himiceskij analiz vozduha promislenyh pred-prijatij*. Himija, Leningrad.(1973).
 13. Rossiter, C.E.: Relation of Lung Dust Content to Radiological Changes in Coal Workers. *Ann. of the New York Academy of Sciences*. 200:465-477 (1972).
 14. Vasilenko, E.S., Sluzker, A.S.: O vlianii nekotoryh svoistv ugol'nyh plastov na zaboлеваemost gomorabochih. *Gig. Truda i Profzabolevanii*. 2:12-15 (1982).
 15. Weller, W.: Specific Harmfulness of Respirable Dusts from West German Coal Mines. *Ann. Occup. Hyg.*, 26:491-503 (1982).

PREVALENCE OF PNEUMOCONIOSIS IN ZIMBABWE'S COAL AND HARD ROCK MINES

R.S. BALOYI • M.R. Cullen*

Department of Occupational Health, Safety and Workers' Compensation, Harare, Zimbabwe
*Yale—New Haven Occupational Medicine Program, Yale University, New Haven, CT, USA

ABSTRACT

Periodic X-ray examination has been required of all workers at Zimbabwe's mines since 1984; all films are centrally reviewed by the National Pneumoconiosis Medical Bureau, where files on some 27,000 workers now are housed. In order to establish a surveillance data base, random samples of first examinations performed under the new law—were selected for various mines. The X-rays were read by a NIOSH B-reader (MRC) blinded to prior reading or work history; subsequently job category and years service were abstracted from the file. Based on these cross-sectional surveyed prevalence roles of radiographic pneumoconiosis were established for the nation's single coal mine and large mines of copper, gold, chrome and nickel.

The prevalence of pneumoconiosis was determined using the ILO classification system. In coal workers, radiographic changes were rare prior to 15 years of service, after which CWP appeared in more than 20% of the films. Some cases of presumed silicosis appeared after 10 years, reaching a 20% prevalence among workers with 20 or more years exposure in gold, copper and chrome mines.

Complicated pneumoconiosis was not seen, but this may be an anti-fact due to the cross-sectional methodology employed. However, the preliminary results provide a data base for developing preventive and protective measures and a surveillance programme.

No Paper provided.

PULMONARY MICA DUST LESIONS

S.H. ZAIDI* • R.K.S. Dogra • Ravi Shanker

*B-8b, Nirala Nagar, Lucknow, India-226007

Industrial Toxicology Research Centre, M.G. Marg, Lucknow, India-226001

ABSTRACT

In Bihar state (India), there is a vast reserve of muscovite mica and associated mining and processing industry which employs a large number of workers. A high incidence of respiratory morbidity has been reported among them. The present report deals with studies made on pulmonary tissue of 667 domestic animals which were exposed to dust pollution in the mica mining area. Histological examination of lungs revealed focal deposits of birefringent dust particles predominantly in the parenchyma and adjacent to bronchioles and alveolar ducts. The predominant feature was the absence of any fibroblastic reaction in spite of heavy dust load. Experimental studies on rats injected intratracheally with respirable mica dust (50 mg/animal) obtained from the mica mine revealed foreign body granulomatous reaction in lung at 15 days. The reaction had markedly regressed by 90 days with only tiny deposits of mica dust in the parenchyma, and which did not incite any fibrotic reaction by 270 days. Our preliminary studies with infection and mica dust suggest that the fibrotic lesions induced by mica in human cases may be due to an infective factor. The significance of present observations in domestic and laboratory animals on "pure mica dust granuloma" and "infective mica dust granuloma" has been discussed.

No Paper provided.

MAIN MEASURES FOR CONTROLLING COAL DUST IN PLACE AT THE LONGWALL SHEARERS IN CHINA

CHAI ZAO-CI

Bureau of Mine Safety and Health Inspectorate, Ministry of Labor, Beijing, China

ABSTRACT

To control coal dust in place at the longwall shearers faces have been one of the particularly difficult tasks. Several kinds of measures have been developed and used in this field in China. The technique of pre-injecting water into the coal seam at high pressure is most popular at the present and greatly benefitting almost all the nation's miners working at the longwall faces by reducing the dust concentration in the airflow in a large quantity. The experiences of mixing certain chemical materials in the injected water show obviously better effect. Another development to catch the fine coal dust produced in the cut-loading operation is the usage of a new water spring device called "Pneumatic-pressure water spring." By means of it the spring water particles with smaller diameter, higher initial flying speed and closer density lead to higher spring effect and lower consumption of water (down to 1/3 compared with the ordinary spring).

No Paper provided.

THE PNEUMOCONIOSIS CONTROL IN CHINA

LIN XIAO NING

Inspection Bureau of Occupational Safety and Health
The Ministry of Labour of China.

Since the founding of the People's Republic of China, Chinese government has attached great importance to protecting worker's safety and health in the production process and made safety production a basic national policy. It has improved worker's working conditions, obvious achievements have been made in occupational safety and health.

Chinese government pays more attention to preventing pneumoconioses and performs the policy of prevention as leading role. A lot of work have been done in inspection, scientific research, and publicity as well as education.

LEGISLATION OF LABOUR PROTECTION

In early 1956, China state Council published "The decision of prevention of dust hazards in factories and mines" and "The regulation of safety and health in factories." In recent years, the state has promulgated "Standard of sanitation design of industrial enterprise," "classification of hazard levers due to exposure to industrial dust," "Methods for airborne dust measurement in working place" and other national standards. In 1987, Ministry of labour, Ministry of Public Health, All-China Federation of Trade Unions revised "The scope of occupational diseases and the regulation of treating patients on occupational diseases." There are 99 kinds of occupational diseases in it, and 12 kinds are pneumoconioses which include quartz lung, asbestosis, carbon-dust lung, anthracosis and so on. The stipulation of regulations and standards above mentioned provide a basis for pneumoconioses prevention and cure.

NATIONAL INSPECTION

In China, the labour department at all levels represents state to inspect the situation of occupational safety and health in enterprises. The Ministry of Labour of the People's Republic of China is in charge of comprehensively managing and conducting nationwide inspection work about safety and health. Inspection organizations of safety and health have been set up in the labour department at all levels. In order to develop inspection tasks, 174 testing and examination stations of occupational safety and health have been established, more than 15,000 inspectors have been allocated.

In order to reduce the dust hazard and control the pneumoconioses, nation's inspectors are carrying out examination and approval to the engineering construction projects, and dust-proof equipment is required to be simultaneously designed, constructed, put into production with the major building in the construction, rebuilding, extension projects.

Meanwhile inspectors supervise and urge enterprises and factories to adopt activity prevention measures to improve working condition and reduce the dust density in workplaces, and to implement and perform the nation's regulations. At the 4th national conference on dust-proof and toxic-proof in 1985, the government clearly claimed to rapidly bring the dust hazard under control and improve labour conditions in policies and technical measures. They are as follows:

1. Resolving dust problem in some major trades which are coal mine, metal mine, building material trade, glass, ceramics, refractory, asbesting, casting, tunnel cutting engineering.
2. Control three most hazardous kinds of dust which are asbestos dust, quartz dust, carbon-dust.
3. Adopting advanced and comprehensive technical measures of dust-proof, such as wetting working, ventilating and airtighting.

The works above mentioned play an important part in reducing dust hazard and controlling pneumoconioses.

SCIENTIFIC RESEARCH, PUBLICITY AND EDUCATION

Ministry of labour has formulated "The scientific and technical plan of labour protection in 2000." It has attached great importance to the engineering and technique of reducing dust hazard and controlling pneumoconioses in it. There are 23 institutes of labour protection in the whole nation. Many of their tests are researching techniques of dust-proof and dust detectors, stipulating standards concerning dust-proof, giving advice and suggestions to enterprises.

Seventy-two labour protection education and training centres have been set up. Labour protection education offices have been established in more than 3000 large and medium enterprises. A national science and technologic information network of occupational safety and health has an initial scale. They play an important part in pneumoconioses control.

In the past ten years, the problems involved in occupational safety and health have become more complex, with the implementation of reform and open policy, growth of economy and various types of individual enterprises. It is therefore indispensable for the Chinese government, while continuously developing its economy, to learn the advanced experiences from other countries and take further action to secure a decrease in occupational accident and to prevent occupational diseases.

DOSE-RESPONSE RELATIONSHIP BETWEEN ASBESTOS EXPOSURE AND INCIDENCE OF ASBESTOSIS

HUILAN ZHU, et al.

Institute of Occupational Medicine Chinese Academy of Preventive Medicine
Beijing, People's Republic of China

INTRODUCTION

The asbestos products of a Beijing asbestos factory include textile products, brakes, rubber, asbestos-cement and thermal insulation materials. More than 80% of the raw materials was chrysotile. Both men and women were employed. The purpose of this research was as following:

1. To study the reliability of currently used hygiene criteria of asbestos in China.
2. To provide the scientific basis for the modification of these criteria in the future.

MATERIALS AND METHODS

Beijing asbestos factory was set up by combining three small factories in the 50's. No anti-dust measures were taken at that time. All procedures were operated openly with very simple equipment; the asbestos concentration reached as high as 300 mg/m³. Since the 1960's, the working conditions have been improved and the asbestos concentration declined greatly. At the end of 1982, 90% of the dust samples had reached the recommended standard.

The asbestos concentration in the air of workplaces was collected from 1957 to 1982. The data from 1967 to 1972 was missing; it was estimated as the average of those in 1966 and 1972. The asbestos concentration level from 1951 to 1956 was calculated as 1.5 times higher than those in 1957.

There are three types of workshops: Raw material, carding and spinning, weaving. In this study, the subjects who worked for more than 1 year were selected. They should not have any exposure history in other factories and mines. According to this criterion, 532 workers who had regular X-ray photographs were selected, among which there were 46 cases with asbestosis at stage I.

At first, the data of dust concentrations were rearranged according to the type of work, and average of the annual asbestos concentrations were estimated year by year. Secondly, for each worker who was exposed to asbestos the actual exposure duration was recorded. An adjustment was given to those who only worked in the workshops part-time, such as repairmen. At last, for each worker, the cumulative dust exposure (D) was estimated according to equation (1).

$$\text{Cumulative dust exposure (mg/year)} = \sum C_i T_i \quad (1)$$

where, C_i is the asbestos concentration (mg) at the working time interval, T_i is the length of the i working interval in year.

Both life table and linear regression models were used to analyze the relationship between the incidence of asbestosis and the asbestos exposure.

RESULTS

Life Table Model³

Table I was constructed according to the principles of life table model. Let L_x be the total number of observed workers entering the x cumulative exposure interval, L_{x+a}=L_x-W_x-dx; dx the number of workers who got asbestosis in this interval; W_x the number of censored; N_x the corrected number (N_x=L_x-W_x/2). Other columns in Table I are calculated by using equations (2) to (5):

$$p_x = dx/N_x \quad (2)$$

$$q_x = 1 - p_x \quad (3)$$

$$x + aQ_0 = q_0 q_1 q_2 \dots q_x \quad (4)$$

$$x + aP_0 = 1 - x + aQ_0 \quad (5)$$

where p_x is the probability of asbestosis in x interval

q_x is the probability of not suffering from asbestosis

x + aP₀ is the cumulative probability

x + aQ₀ is the cumulative probability of not suffering from asbestosis

It is shown from Table I that the probability of cumulative incidence could be 2.54% when the cumulative exposure from 0 to 199 mg/yr. It is clear that the cumulative incidence rate increases as the cumulative exposure increases. The incidence rate might rise up to 56.3% if the cumulative exposure reaches 800 mg/yr. It means that more than half of the employees will suffer from asbestosis if their cumulative exposure reached 800 mg/yr.

In order to search if there is any linear correlation between the asbestos exposure and the asbestosis incidence rate, logarithmic transformation and logit transformation were made to the columns 1 and 9 in Table I respectively (Table II). It is shown that there exists a linear correlation between the logarithm of asbestos exposures and the logit value of cumulative asbestosis incidence rate (Figure 1).

The regression line is obtained from Table II:

$$\text{Logit} = 5.08 \text{LgD} - 15.23 \quad (6)$$

(r=0.99 P<0.05)

Table I
Probability of Cumulative Incidence under Different Cumulative

Cumulative exposures (mg.yr)	Lx	Wx	dx	Nx	px	qx	x+aQo	x+aPo
(1)	(2)	(3)	(4)	(5)	(6)	(7)	(8)	(9)
0-	532	356	9	354	0.0254	0.9746	0.9746	0.0254
200-	167	62	15	136	0.1103	0.8897	0.8671	0.1329
400-	90	38	11	71	0.1549	0.8451	0.7328	0.2672
600-	41	12	3	35	0.0857	0.9143	0.6700	0.3300
800-	26	6	8	23	0.3478	0.6522	0.4370	0.5630
1000-	12	9	0	7.5	0	1.0000	0.4370	0.5630

Table II
Conversion Value from Table I

Logarithmic dose (upper limit)	* logit
2.30	-3.65
2.60	-1.87
2.78	-1.01
2.90	-0.71
3.00	0.25
3.08	0.25

*logit = $-\ln[P/(1-P)]$, P is the cumulative asbestosis rate

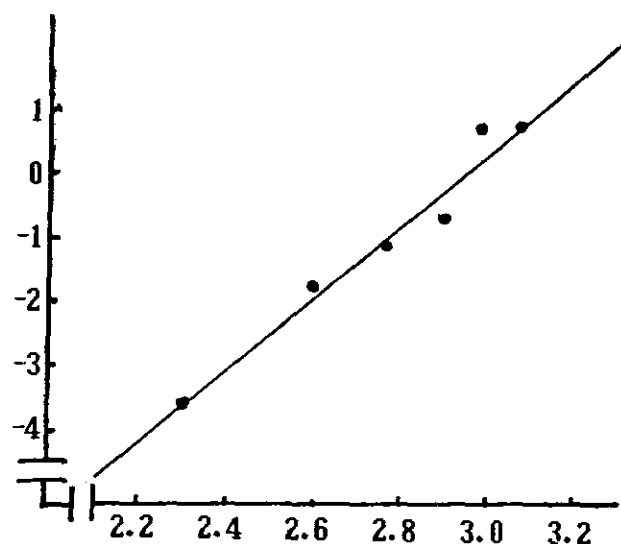

Figure 1. The correlation between logarithmic doses and logit.

$$Y = 3.4806 + 0.1174X \quad (7)$$

$$Y = 1.9858 + 0.1867x \quad (8)$$

where Y is the probit
X is the working duration (in year).

Columns (2) and (3) are estimated from equations (7) and (8) respectively. Columns (4) and (5) are the reverse transformations from columns (2) and (3). The values in column (6) are calculated according to equation (9).

$$P = B/A.K.1000\% \quad (9)$$

where K is called prevalence rate of asbestosis. In the last column are the expected cumulative prevalence rates estimated from equation (10).

$$P = -11.8064 + 4.47X \quad (10)$$

where X is the mid-value of working duration.

Where, D is the cumulative asbestos exposure (mg/yr)

From equation (6), the conclusion could be made that the cumulative asbestosis rate will not be greater than 1% if a person worked for 40 years under the condition that the average asbestos concentration was not higher than 3.09 mg/m³.

Regression Model⁴

This model was introduced by Dr. Tian in 1980. The principle is to translate the worker's rank into probits then by using regression model to find the relationship between the asbestosis rate and asbestos exposure. The procedure is as follows:

First to build Table III. The purpose is to illustrate the relationship between working duration (in year) and the asbestosis incidence rate among the employees. All employees were divided into two subgroups, one with asbestosis, the other without asbestosis, two equations could be given by using the least square method separately:

Table III
 Estimation of Asbestosis Prevalence Rate with Different Length of Working Time

Length of Working time X	probability units		cumulative frequency		P	\hat{P}
	exposed workers with workers asbestosis stage I	exposed workers with workers asbestosis stage I	A	B (B/A. K. 1000%) (%)		
5	4.0677	2.9191	0.176	0.019	9.34	10.54
7	4.3025	3.2924	0.243	0.044	15.66	19.48
9	4.5374	3.6657	0.322	0.092	24.71	28.42
11	4.7722	4.0391	0.410	0.169	35.65	37.36
13	5.0071	4.4124	0.503	0.279	47.98	46.30
15	5.2419	4.7857	0.596	0.416	60.38	55.24
17	5.4767	5.1590	0.684	0.564	71.32	64.18
19	5.7116	5.5323	0.762	0.703	79.80	73.12
21	5.9464	5.9057	0.829	0.818	85.35	82.06
23	6.1813	6.2790	0.882	0.900	88.27	91.00
25	6.4161	6.6523	0.922	0.951	89.22	99.94

Table IV
 Recommended Concentrations Under Different Models (in mg/m³)

Cumulative Prevalence	Life Table Model	Regression Model
0.005	2.26	1.83
0.010	3.09	2.19

For the 532 employees, another equation was given where the variable is working duration, and the dependent variable here is the cumulative asbestos exposure.

$$D = 23.7015 + 13.1195X \quad (11)$$

where D is the expected asbestos exposure, X is working duration.

By combination of equations (10) and (11), the temporal variable working duration will be eliminated, we get equation (12) which reveals the relationship between the cumulative prevalence rate and the cumulative asbestos exposure.

$$D = 58.3668 + 2.9350P \quad (12)$$

Equation (12) could be used to estimate the recommended criteria for asbestos concentration (Table IV).

The recommended concentration is defined in such a way that the probability of asbestosis for the employees who have worked for 40 years under this concentration will not precede 0.5% or 1%.

REFERENCES

- Berry, G., et al: A Study of Dose-Response Relationships in an Asbestos Textile Factory. *Brit. J. Ind. Med.* 36:98-112 (1979).
- Peilian Liu, et al: Asbestosis in a Factory of Shanghai. *Chinese Journal of Preventive Medicine*, 16(3):163-165 (1982).
- Zhaohuan Zhang, et al: A Statistical Method for Assessing the Relationship between Dust Exposure and Dust Diseases. *Chinese Journal of Preventive Medicine* 18(1):7-9 (1984).
- Fengtiao Tia, et al: The Methodology in Studying the Relationship between Dust Exposure and Incidence of Silicosis. *Journal of the Institute of Health* 9(2):108-116 (1980).
- Fengtiao Tian: The Method of Field Studies for the Dust Concentration Maximum Permissible Level. *The People's Medical Publishing House, Beijing*, pp. 30-40 (1985).

The Sanitary and Antiepidemic Station of Chaoyang district of Beijing participated in this work.

THE CORRELATION BETWEEN SILICOSIS AND LUNG CANCER —PATHOLOGICAL EVIDENCES FROM 5 AUTOPSIED CASES

YU TONG

The Occupational Diseases Hospital, Second Railway-Engineering Bureau
Ministry of Railways of China, Sichuan Chengdu

Recent epidemiologic studies suggested a high risk of lung cancer among workers exposed to silica dust. The Occupational Hospital, an organization to cure workers with silicosis caused by railway-tunnel-building, also found that among these patients the risk of dying from lung cancer was greater than comparison population. This paper reported certain pathological correlation between silicosis and lung cancer based on pathological materials.

ILLUSTRATIVE CASES

Case 1: 53 year-old man, tunnel-building for 9 years, with massive silicotic fibrotic lesions in both upper lobes of lungs. In the subpleural of both base parts of lungs, was found numerous greyish-white nodules, about the size of peas (Figure 1). Microscopically, the bronchiolar epithelium showed obvious hyperplasia, the dilated bronchiolar lumens were full of hyperplastic epithelium. A few of these bronchioles showed anaplastic change and began to invade into surrounding tissues, presenting an early appearance of adenocarcinoma (Figures 2, 3).

Case 2: 58 year-old man, tunnel-building for 34 years, with history of smoking. There is a massive silicotic fibrotic lesion associated with tuberculosis in right upper lobe. The bronchogenic carcinoma also developed in the same lobe (Figure 4). Why did the cancer of bronchus develop in the same lobe? The bronchus near the massive silicotic lesion showed deformation and their epithelium often being destroyed, and proliferation metaplasia anaplasia ensued, finally squamous cancer developed (Figures 5, 6).

Case 3: 58 year-old man, tunnel-building for 8 years, with history of smoking. In addition to the generally distributed silicotic nodules throughout the whole lungs, the nodules in the left upper lobe showed tendency to coalesce. In the site where the superior and inferior bronchi bifurcated, there was a large silicotic enlarged lymph node 2.3 cm in diameter which oppressed on the superior and inferior bronchi, the cancer developed right there (Figure 7). Microscopically, showed low-differentiated large cell cancer (Figures 8, 9).

Case 4: 60 year-old man, railway-building for 38 years, with history of smoking. In both upper, middle and lower lobes scattered with silicotic nodules. In the middle lobe of the right lung (near the hilar), there was a massive silicotic fibrotic lesion (5×2 cm). In the right hilar region, a bronchogenic large tumor surrounded the bronchus and obstructed its

lumen (Figure 10). Microscopically, that was a low-differentiated small cell cancer (Figures 11, 12).

Case 5: 58 year-old man, tunnel-building for 6 years, with history of smoking. All lobes of both lungs scattered with silicotic nodules. In the upper lobe of left lung there was a (5×4.5×4.5 cm in size) black and white interlacing region.

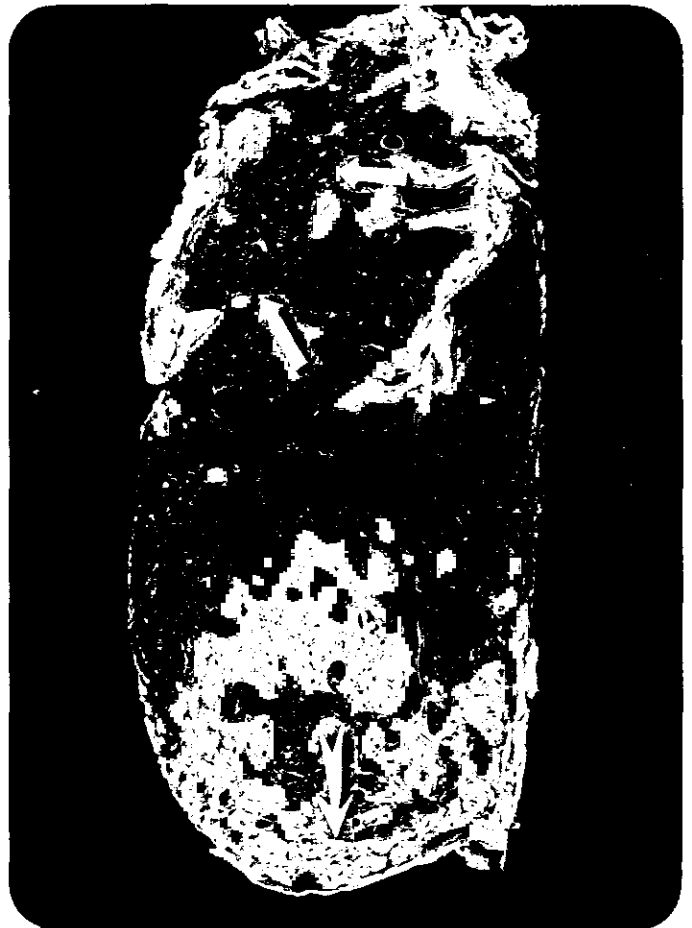

Figure 1. (Case 1): In the subpleural silicotic collagenous region of base part of right lung was found numerous greyish-white nodules. (forked tail arrowed).

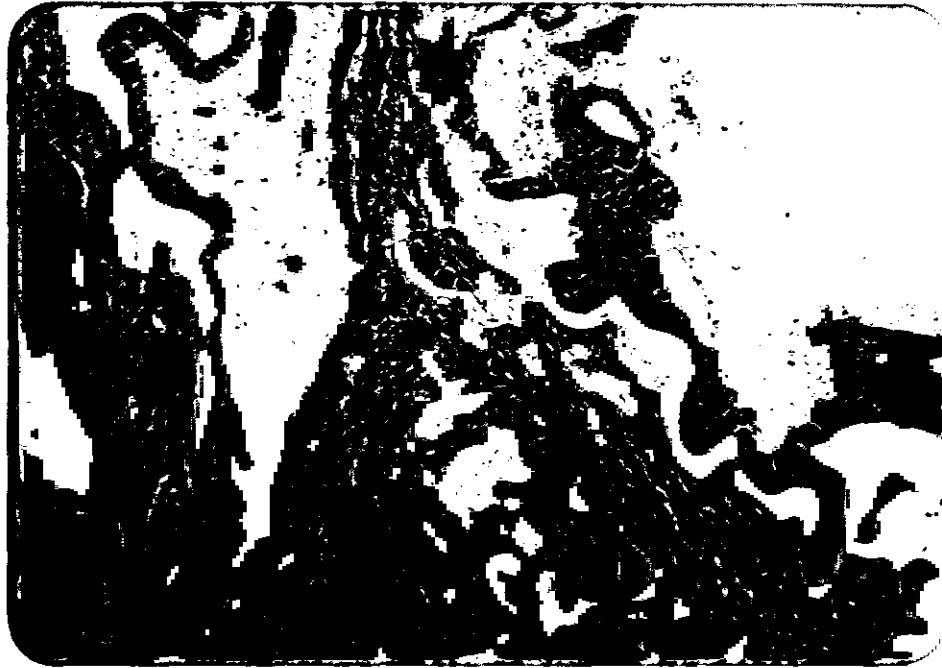

Figure 2. (Case 1): A few of greyish-white nodules present an early appearance of adenocarcinoma (H&E, $\times 50$).



Figure 3. (Case 1): Higher power view of cancer shown in Figure 2 showing poorly differentiated tumour cells (H&E, $\times 200$).

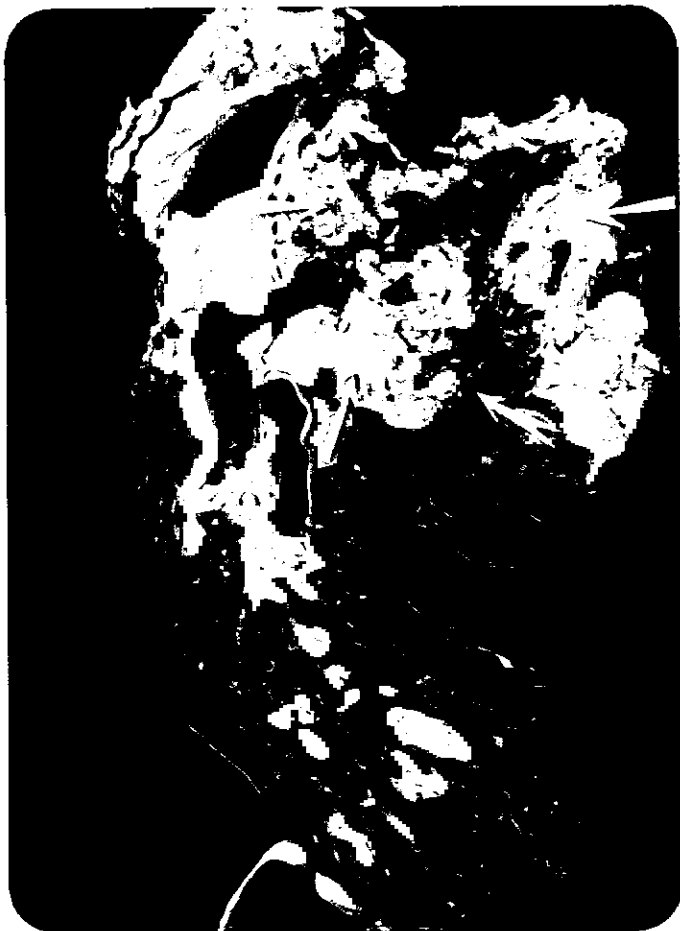

Figure 4. (Case 2): Bronchogenic cancer developed in the same lobe that the massive silicotic lesion existed. (Forked tail arrowed the silicotic lesion; the others arrowed the the cancer and tuberculosis area.)

In that region there was a silicotic fibrotic coalescing lesion in the size of 2×1.5 cm (Figure 13). Microscopically, the white region was cancer. Histologically, it was bronchiole-alveolar cancer (Figure 14). This case associated with tuberculosis too (Figure 15).

DISCUSSION

From the pathological viewpoint, in those 5 cases of silicosis associated with lung cancer, the development of cancer all have some correlation with the preexisting silicosis. In two of those five cases (Cases 2, 5), the cancer developed on the same lobe the massive silicotic lesion existed. In one case (Case 4) the cancer developed in the right hilar bronchus close to the massive silicotic fibrotic lesion. In one case (Case 3) the cancer developed on the site where the left bronchus bifurcated into superior and inferior bronchi oppressed by the silicotic enlarged lymph node. In another case (Case 1) the cancer developed from multiple deformed bronchioles which remained in the subpleural silicotic collagenous region.

Emmanuel Farber¹ put forward that "Dependence on cell proliferation for initiation" of carcinogenesis and "In fact, we think that the rate-limiting step in some types of cancer development, such as in the liver, the urinary bladder, and the pancreas, to name but three, may not be the exposure to a carcinogen but rather the presence or absence of concomitant cell or tissue damage." At silicosis it can be seen that varied silicotic lesions of the lung often caused deformation stenosis of the bronchus and the mucomembrane of bronchus often continuously damaged. It created an important favourable factor for the development of lung cancer. It is well known to us that Stenbeck et al.¹ intratracheally instilled SiO_2 or Hap or SiO_2 together with Hap to the syrian golden hamsters, the lung cancer incidence of the latter group was 4 folds more than the Hap group. Holland et al.¹ made an experiment that Fischer-344 rats were exposed to silica (Mun-U-Sil) 6 hours per day, 4 days a week for 24 months at an airborne concentration of 12 mg/m^3 . It produced a respiratory epithelium tumor incidence of 27%. Hesterberg et al.³ cultivated hamster's embryo cells with Min-U-Sil (a high SiO_2 content) showed tumor transmutation.

Holland¹ suggested that in his animal experiment the carcinogenesis of the silica were due to lung scarring produced by silicotic lesion in rats, but in our study only one case (Case 1) belongs to the scar cancer. Saffiotti³ suggested that the target cell of the silica carcinogenesis is bronchiole-alveolar cell but in our study only one case (Case 5) is bronchiole-alveolar cancer. All others (Cases 2, 3, 4) the cancer developed on the basis of repeat bronchus and their mucomembrane damage caused by the silicotic lesions. The development of those bronchogenic lung cancers corresponded more or less with the pattern of Farber and animal experiment of Stenbeck.

REFERENCES

1. David, F. et al.: Does occupational exposure to silica cause lung cancer? *Am. J. of Industrial Medicine*, 3:423-435, 1982.
2. Farber, E.: Chemical, Evolution, and Cancer Development. Rous-Whipple Award Lecture. *Am. J. Pathol.* 108:270-275, 1982.
3. Saffiotti, U.: Silica Silicosis and Cancer, p. 287, Praeger Publishers, New York, 1986.

ACKNOWLEDGEMENTS: I would like to thank: the director of occupational hospital, Dr. Li-chunfang for his support in this work; Dr. Zhang-jisheng for grammatical consultation; Dr. Peng-hongquan for passing me the information that the VIIth IPC would be held on August 23-26, 1988; Comrade Tao-xiaohua for typing this manuscript; Comrade Yang-dongke for photography.



Figure 5. (Case 2): The squamous carcinoma developed on the bronchus near the massive fibrotic lesion (H&E, $\times 50$).



Figure 6. (Case 2): The massive silicotic lesion associated with tuberculosis in the same lobe. The alveolar filled with macrophages and Langhan's giant cells and lymphocytes (H&E, $\times 100$).



Figure 7. (Case 3: In the site where the left bronchus bifurcated, there was a large silicotic enlarged lymph node (forked tail arrowed, the white spot is a metastatic focus), which oppressed on the bronchi, the cancer developed right there (single tail arrowed).



Figure 8. (Case 3): Microscopically, this cancer shown in Figure 7 shows an appearance of low-differentiated large cell cancer (H&E, $\times 100$).



Figure 9. (Case 3): The malignant cancer cells spread via perivenous channels (H&E, $\times 200$).

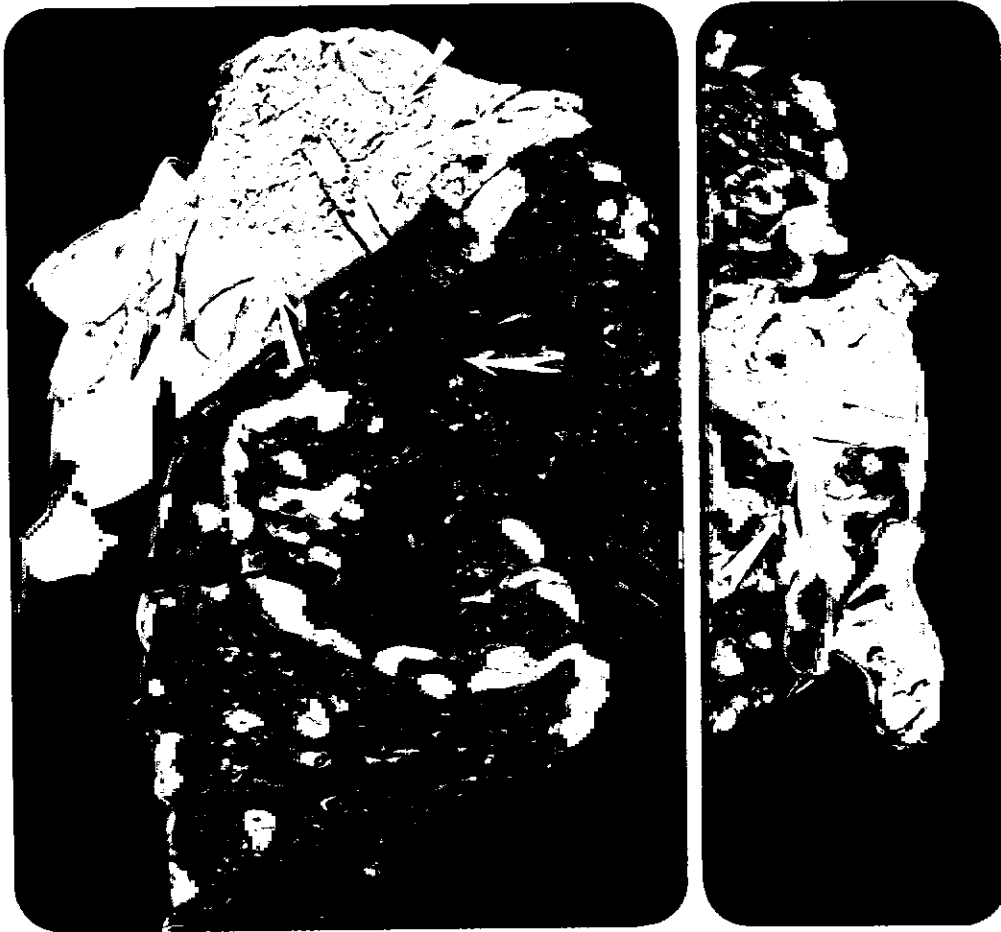

Figure 10. (Case 4): The massive silicotic lesion near the right hilar (forked tail arrowed) and in the hilar region a bronchogenic large tumor developed (single tail arrow). The right photo shows the bronchogenic cancer obstructed the bronchial lumen.

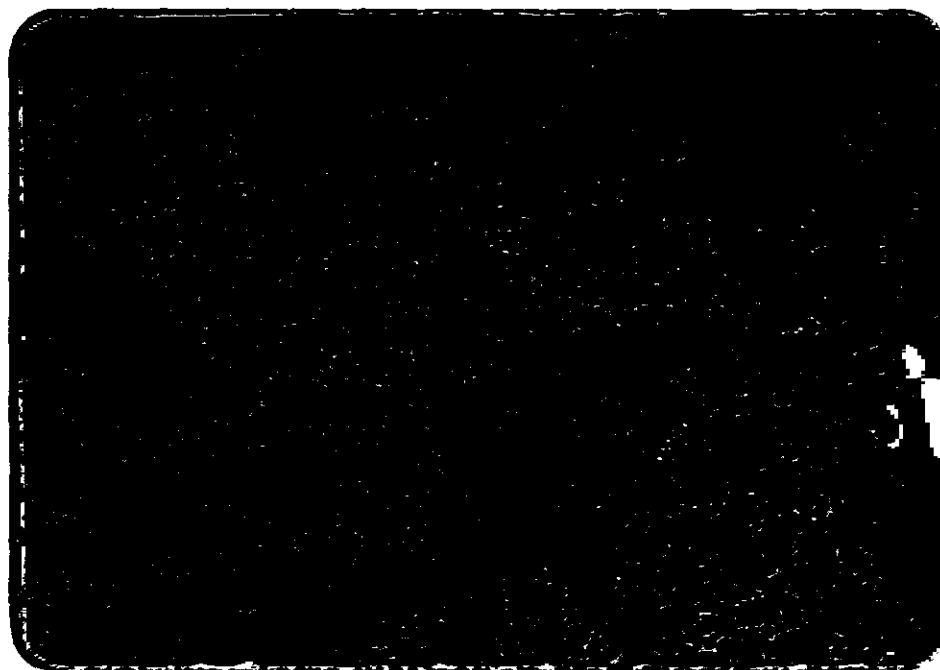

Figure 11. (Case 4): Microscopically, this cancer was a low-differentiated small cell cancer (H&E, $\times 50$).

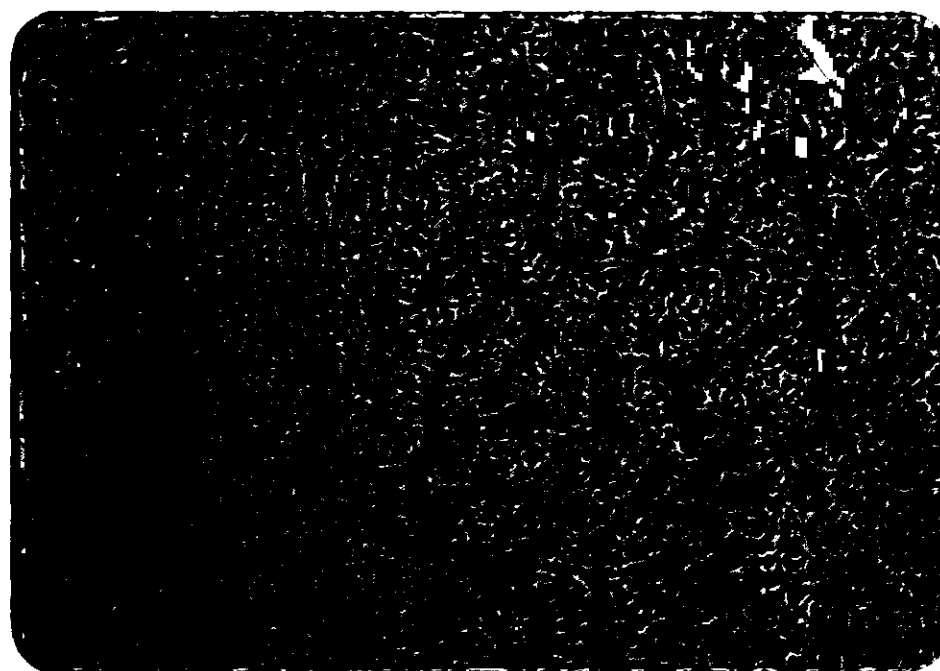

Figure 12. (Case 4): Metastatic cancer in the liver shows an appearance of adenocarcinoma (H&E, $\times 100$).

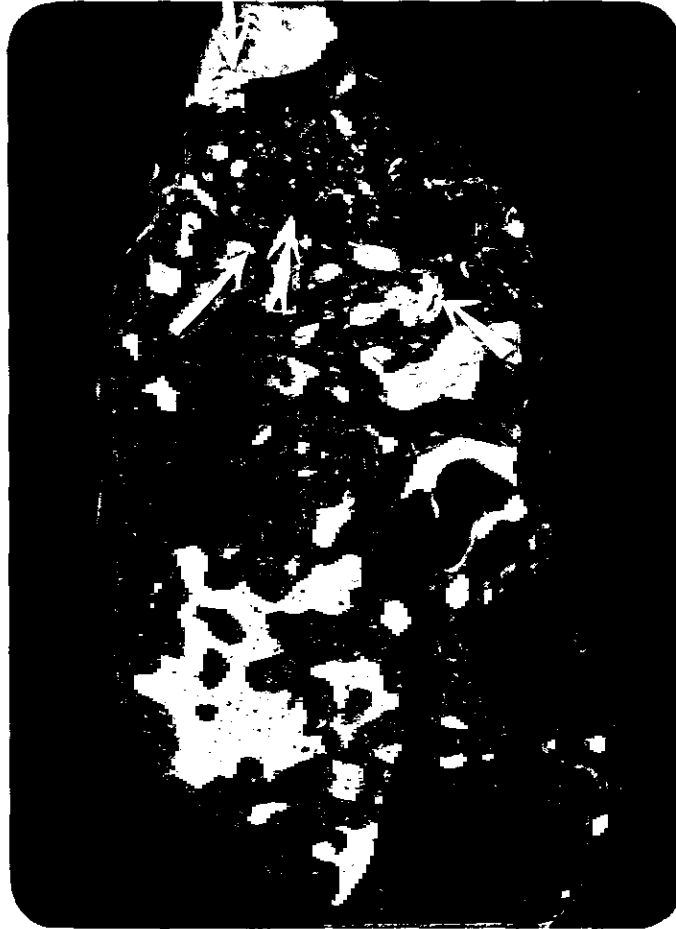

Figure 13. (Case 5): In the upper lobe of left lung there was a silicotic fibrotic lesion in the size 2×1.5 cm (forked tail arrow) surrounded with cancer (single tail arrowed area).

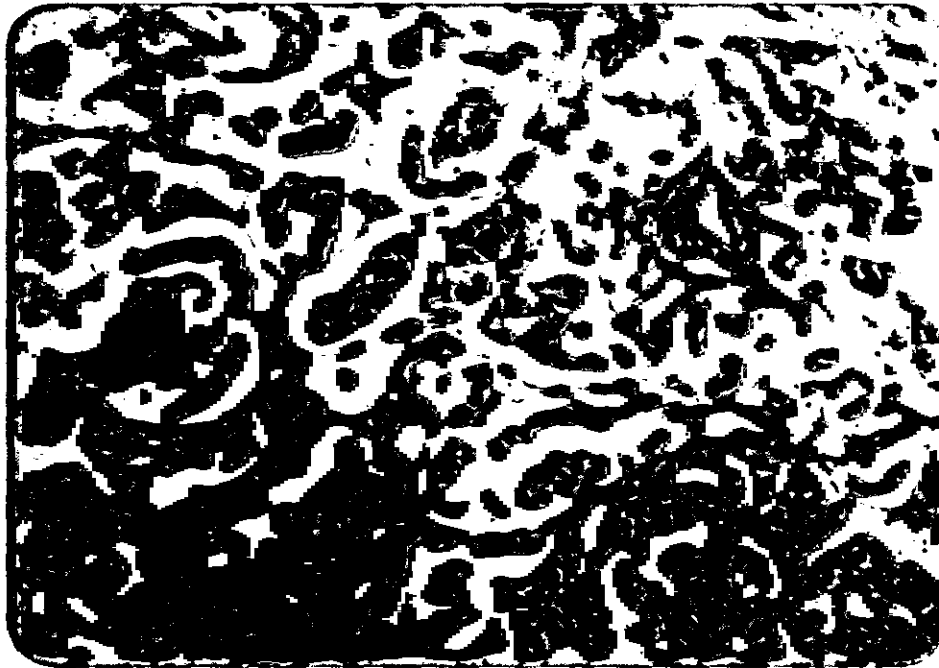

Figure 14. (Case 5): Microscopically, this cancer was a bronchiole-alveolar cell cancer (H&E, $\times 100$).

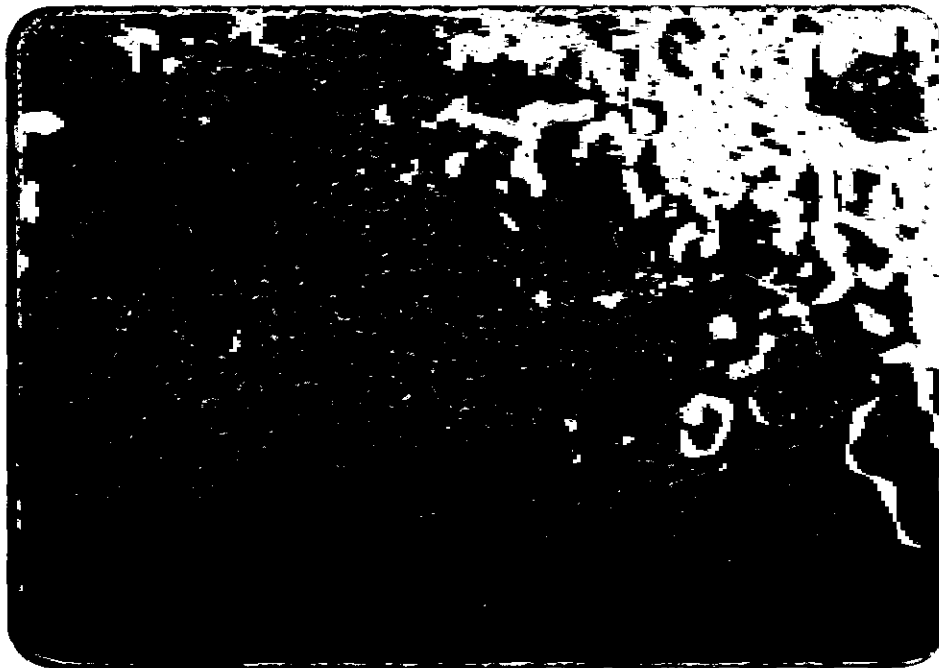

Figure 15. (Case 5): This case associated with tuberculosis too. Note the tubercles with caseation (H&E, $\times 50$).

BEHAVIORAL TOXICITY IN SILICOTIC PATIENTS (Pilot Study)

FENGSHENG SONG* • Jianxin Zhang† • Guanggu Yuan* • Shizheng Wu* • Fujun Chen‡

*Department of Neurology, First Affiliated Hospital

†Institute of Silicosis

‡Occupational Hospital

West China University of Medical Sciences, Chengdu, China

Silicosis is the most common and most severe occupational disease in China. Most silicotic patients complain of amnesia, concentration difficulties and psychomotor slowing, etc. Up to now these problems have not drawn sufficient attention in China. In order to explore the neuropsychological impairment in silica dust-exposed workers, the Wechsler Adult Intelligence Scale—Revised in China (WAIS-RC)¹ and some of the tests on the Wechsler Memory Scale—Revised in China (WMS-RC)² were used. A summary of the use of this battery in detecting the behavioral effects of silicon on silicotic patients is given.

SUBJECTS

Eight men and one woman exposed to silica dust were included in our study. All of these cases were exposed to silica dust for at least 4 years and had been diagnosed as silicosis by the panel of experts authored by national health ministry and Sichuan provincial government. The ages of the cases were from 41 to 68 (55.33 ± 10.56 years). All the cases had grown up in the countryside and had received 1 to 6 years (4 ± 2 years) education. Details of the study subjects are summarized in Table I.

Table I
Details of the 9 Patients with Silicosis

Number of patient	Sex	Age (year)	Education received (year)	Duration of exposure to silica dust (year)
1	male	61	6	24
2	male	64	1	20
3	male	47	4	4
4	male	41	5	4
5	male	68	3	22
6	female	62	1	4
7	male	52	6	6
8	male	42	6	15
9	male	43	4	10
		53.33 ± 10.56	4 ± 2	11.89 ± 8.49

RESULTS

The detailed results of neuropsychological tests are shown in Table II. Almost all the cases got full scores on experience and orientation subtests of WAIS-RC. Seven of nine cases (77.8%) got only zero scaled score on the test of counting from 1 to 100. And none of the cases got more than 7 scaled scores on the test of reversing from 100 to 1. No one could completely recall the short story and no one could get more than 8 scaled scores. There were more than 5 cases (55.6%)

failed to perform some subtests on WAIS-RC, with scores lower than $\bar{X} - D$ according to age-appropriate norms.

DISCUSSION

Unfortunately, we haven't finished the whole controlled trial, so we cannot statistically process the data. The results suggested that patients with silicosis suffered from some impairment of short-term memory, but remote memory was spared. The poor performance on subtests of reversed counting (from

Table II
Results of Behavior Tests on 9 Patients

Variable	Subjects								
	1	2	3	4	5	6	7	8	9
experience	5	4.5	4	5	4.5	4	5	5	5
orientation	5	5	5	5	5	5	5	5	5
1--100 (scaled 0	0	0	8	0	0	0	0	0	3
100--1 score)	4	6	6	0	3	2	4	1	7
short story	6	4	6	1.5	2	2	11	5	2
digit span									
forward	6	6	7	9	8	8	7	7	6
backward	3	3	4	3	3	3	5	6	4
information	14*	11*	16	11*	8*	9*	11*	19	16
comprehension	13*	16	14	15	10*	14*	16	15	14*
arithmetic	8*	11	8*	11*	11	7*	9*	14	8*
similarity	6*	4*	9	3*	2*	2*	5*	18	8*
vocabulary	38	34	14*	36	21	21*	28*	71	38
digit symbol	32	23	19*	19*	25	10*	14*	36	27*
picture com-									
pletion	9	7*	8*	9*	5*	5*	5*	14	6*
block design	14*	28	20*	26	26	22*	24	26	18*
picture arran-									
gement	20	12	8*	18	8*	4*	16	24	4*
object as-									
sembly	10*	22	21	21*	9*	13*	25	24	29

* less than $\bar{X} - D$

100 to 1) and digits backward gave us a deep impression that the mental tracking ability was markedly impaired. Especially when we compare the scores of digits backward with those of digits forward, the difficulties of attention and concentration will be more obvious. All the cases achieved a forward span of 7 or more but recalled much fewer digits reversed, which meant the patient's mental tracking deficits were much more severe than verbal memory difficulties. When doing arithmetic, all the cases asked us to repeat questions for 2 to 9 times (4.78 ± 2.64). We think the lower scores on arithmetic are partly due to attention difficulties and short-term memory disorders.

We found the patients did serial counting from 7 to 100 very slowly and most of them got only zero scaled score. We believe this kind of operation measures speed of response rather than long-term memory. Because digit symbol test is the one most likely to be sensitive to psychomotor slowing,^{3,4} the poor performance of this test indicates some impairment in this aspect. Although the results of other tests showed some impairment, we can't confirm their significance because of lack of controlled group.

According to this pilot study, we could conclude that exposure to silica dust can produce chronic toxic effects on human behavior, which are quite similar to those resulting from organic solvents.^{5,6} We hope the investigation being done by us will give a more clear and definite conclusion.

REFERENCES

1. Yiaoxian Gong. Wechsler adult intelligence scale—revised in China. Changsha, 1982.
2. Yiaoxian Gong. Wechsler memory scale—revised in China. Changsha, 1982.
3. Lezak, M.D. Neuropsychological assessment. 2nd edition. Oxford University Press, New York, NY 1983.
4. Lindström, K. Changes in psychological performance in solvent-poisoned and solvent-exposed workers. *Am. J. Ind. Med.* 1:69-84, 1980.
5. Nicola Cherry. British studies on the neuropsychological effects of solvent exposure. *Scand. J. Work, Environment & Health.* 10 (Suppl.), 10-13, 1984.
6. Lezak, M.D. Neuropsychological assessment in behavioral toxicology—Developing techniques and interpretative issues. *Scand. J. Work, Environment & Health.* 10 (Suppl.), 25-29, 1984.

SIMILARITIES IN LUNG CANCER AND RESPIRATORY DISEASE MORTALITY OF VERMONT AND NEW YORK STATE TALC WORKERS

S.H. LAMM, M.D. • J.A. Starr, MSc

Consultants in Epidemiology and Occupational Health, Inc., Washington, DC 20007

ABSTRACT

The risks from malignant and non-malignant respiratory deaths of New York State and Vermont State talc workers with at least one year of employment have been compared for both miners and millers. The mortality patterns are similar. In both areas, the talc miners have a 4.5 fold risk of lung cancer, and the talc miners have no increased risk of lung cancer. In both areas, all workers appear to have an increased risk of non-infectious, non-neoplastic respiratory disease (NNRD) mortality, although only the Vermont millers show a statistically significantly elevated risk (7.9 fold). Thus, although the New York talc has been described as asbestiform talc and the Vermont talc as non-asbestiform talc, the mortality patterns of the workers appear to be inconsistent with that classification in that their lung cancer mortality rates are no different and only the Vermont talc millers show a significantly increased NNRD mortality.

INTRODUCTION

Studies of talc miners and millers in the New York and Vermont talc industry include analyses of mortality, morbidity, industrial hygiene, and mineralogy. Mineralogical differences between the two talcs have been highlighted. The upstate New York talc contains an elongated particulate not found in the Vermont talc that is considered by scientists at the National Institute for Occupational Safety and Health (NIOSH) as tremolitic asbestos and by scientists at the Bureau of Mines and at the company that owns the plant as true talc particulates and as prismatic non-asbestiform tremolite. NIOSH has called the New York State talc asbestiform talc and the Vermont talc non-asbestiform talc. Leaving the question of the mineralogical label of these particulates to the mineralogists, we have elected to examine the respiratory health outcomes of the employees at these two talc industries.

MATERIALS

The initial shaft of the New York State talc plant was sunk in 1947. Mining and milling operations started in 1948. The mortality experience (1947 through 1978) of all persons hired at the plant between 1947 and 1977 has been reported.¹ Mortality analysis was restricted to the 705 male employees (all caucasian). None of the 36 women employees had died of a respiratory condition. Sixty percent of the men worked at the plant for at least one year; twenty percent for two months to one year; and twenty percent for less than two months. Mortality analysis was reported separately for the 280 white male employees employed at the talc plant for less than one year and for the 425 white male employees employed for at least one year. That report¹ suggested that prior employment jobs accounted for the lung cancer rate.

In-plant job records and prior employment histories on the job applications were analyzed. Employees were classified from the inplant job records as miners (187 worked exclusively in the mine), millers (152 worked exclusively in the mill), and others (34 worked in both the mine and the mill, 11 worked neither in the mine or the mill, and 41 had uninformative records).

The cohort of white male employees of the Vermont talc industry was developed from the records of the Vermont State Health Department's annual radiographic survey of employees of the dusty trades, begun in 1937. Selevan et al. of the National Institute for Occupational Safety and Health (NIOSH) defined the Vermont talc study cohort² as all white males in the Vermont talc industry on or after January 1, 1940 with at least one year of talc employment prior to January 1, 1970. Individuals who had at least two radiographs in the file and who had worked for any of five talc companies in three geographic areas of Vermont were eligible for the study. Mortality follow-up was continued through 1975 of the 392 men determined to belong to the cohort.

Health Department and company records were scrutinized to determine their job assignments, and each cohort member was classified as a miner after having had one year of exposure in the mine and/or as a miller after having had one year of exposure in the mill. 225 workers were classified as miners; 163 workers were classified as millers (of whom 47 had also been classified as miners); and 51 were not classifiable.

METHODS

This report compares standardized mortality ratios (SMRs)

for malignant and non-malignant respiratory causes of death for miners and millers with at least one year of experience in the Upstate New York talc (said to be asbestiform) industry with those in the Vermont State talc (said to be non-asbestiform) industry. Comparison is reasonable, despite the differences in classification variables between the two studies.

RESULTS

The risks of lung cancer and of non-infectious, non-neoplastic respiratory disease (NNRD) for employees with at least one year in the mines or mills of New York State or Vermont State talc industries are presented, analyzed, and discussed below.

Respiratory Mortality of New York and Vermont Talc Workers

	Observed/Expected Ratios		Standardized Mortality Ratios	
	New York	Vermont	New York	Vermont
Lung Cancer				
Millers	1/1.41	2/1.96	071	102
Miners	5/1.15	5/1.09	460*	435*
Others	0/0.55	0/0.61	---	---
Total	6/3.11	7/3.66	1.92	1.91
NNRD				
Millers	2/0.74	7/0.89	270	787*
Miners	2/0.49	2/0.56	408	357
Others	2/0.38	2/0.34	526	588
Total	6/1.61	11/1.79	373*	615*

* - $p < 0.05$, two-tailed Poisson test

The risk of malignant disease of the lung (lung/respiratory cancer) is not increased for millers but is significantly increased (4.5 fold) in talc miners both in New York (4.60) and in Vermont (4.35). No difference in risk is seen between miners and millers of New York and of Vermont (Figure 1). These data are sufficiently strong to rule out with eighty percent confidence an underlying relative risk for New York miners vs. Vermont miners of 1.7 and with about ninety five percent certainty an underlying risk of greater than 2.0.

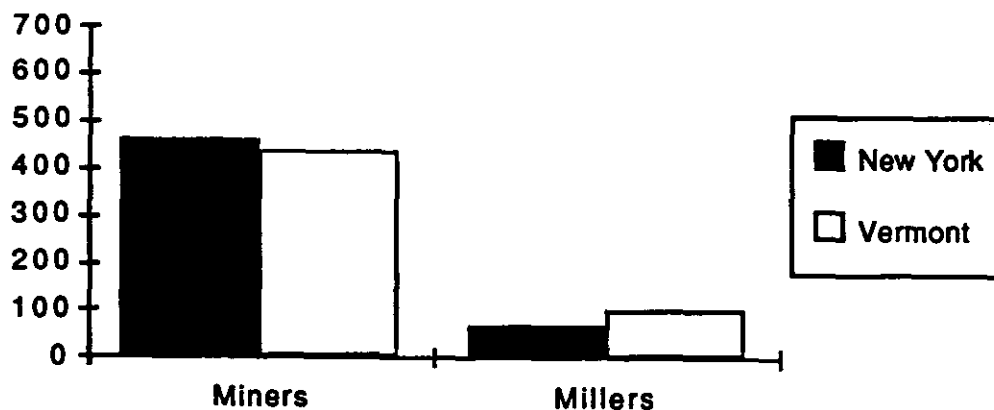

Figure 1. Respiratory or lung cancer mortality risk for miners and millers of New York State and Vermont State talc.

The risk of non-malignant respiratory disease (excluding pneumonia and influenza), i.e., NNRD has a significantly increased risk (almost eight-fold) for Vermont talc millers but not for New York talc millers (risk of 2.7, not significant). The risks for NNRD for miners are calculated to be 4.1 and 3.6 (both non-significant) for those from New York and Vermont, respectively (Figure 2).

As for other respiratory system deaths, influenza or pneumonia caused the death of one New York State talc worker (0.9 expected) but no Vermont talc miner (0.7 expected) or miller (0.8 expected). Mesothelioma caused the death of one New York State talc man (15 years after hire which followed 28 years in mining and construction) and of one Vermont talc man.

DISCUSSION

We have attempted to assemble similarly defined cohorts of New York State and Vermont State talc workers in order to compare the respiratory mortality risks of their miners and millers. The exposures of millers generally exceed that of miners by a factor of two to six. Nonetheless, both groups demonstrate a similar excess lung cancer risk only for their millers and not for their miners. The similar lung cancer risks of the two groups of talc workers exposed to the differently described talcs suggest that the elongated particulates seen in the New York State talc have not introduced an increased lung cancer risk. We further observe that the risk of non-infectious, non-neoplastic respiratory death, while apparently increased in all groups, is significantly elevated only among the Vermont millers.

Standardized mortality ratios (SMRs) were calculated for each group based on age-specific, calendar time-specific, cause-specific mortality rates for white males. The New York State study SMRs had been calculated using U.S. rates with death certificates coded according to the eighth revision of the International Classification of Diseases (ICD). The Vermont State study SMRs were first calculated using U.S. rates and then recalculated by its authors using Vermont State rates for non-malignant respiratory disease and respiratory cancer

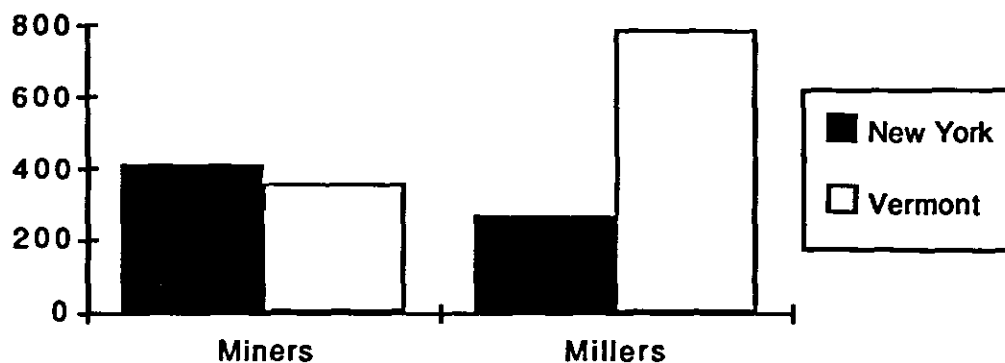

Figure 2. Non-infectious, non-malignant respiratory disease (NNRD) mortality risks for miners and millers of New York State and Vermont State talc.

COMPARATIVE LUNG MORTALITY RISKS of VERMONT and NEW YORK STATE TALC WORKERS with at least one year experience at Talc Plant

	Vermont		New York		New York		New York	
	O/E	SMR	O/E	SMR	O/E	SMR	O/E	SMR
All Emp >1 yr.								
All Causes	44/37.15	118	64/49.83	128	118/83.58	141*	54/33.75	160*
All Cancers			15/9.55	157	26/15.7	165*	9/6.15	146
Lung Cancer	6/3.61	163	6/3.11	193	12/5.01	240*	6/1.90	316*
NNRD	11/1.79	615*	6/1.61	372*	6/2.64	227	0/1.03	---
Millers								
All Causes			20/21.74	92	35/30.97	113	15/9.23	163
All Cancers			3/4.23	71	6/5.94	101	3/1.71	175
Lung Cancer	2/1.96	102	1/1.41	71	1/1.92	52	0/0.51	---
NNRD	7/1.89	787*	2/0.74	270	2/1.02	196	0/0.28	---
Miners								
All Causes			31/16.76	185*	50/26.32	190*	19/9.56	199
All Cancers			10/3.23	310*	15/5.00	300*	5/1.77	282
Lung Cancer	5/1.15	435*	5/1.09	460*	9/1.66	543*	4/0.57	701*
NNRD	2/0.56	357	2/0.49	408	2/0.77	260	0/0.28	---
Others								
All Causes			13/11.33	115	33/26.29	126	20/14.96	134
All Cancers			2/2.09	96	5/4.76	105	3/2.67	112
Lung Cancer	0/0.55	---	0/0.61	---	2/1.43	140	2/0.82	244
NNRD	2/0.34	588.0	2/0.38	526	2/0.85	235	0/0.47	---

COHORT DEFINITION

LUNG CANCER

Cohort Variable	NEW YORK	VERMONT	NEW YORK	
			VERMONT	Observed/Expected
Gender	Male	Male		
Race	White	White		
Employment Dates	1947-1977	1940-1969		
Employment Duration	One Year +	One Year +	Millers 1/1.41	2/1.96
Mortality Dates	1947-1978	1940-1975	Miners 5/1.15	5/1.09
Cohort Numbers			Others 0/0.55	0/0.61
Miners	152	163		
Millers	187	225	SMR	
			Millers 71	102
			Miners 460	435
			Others ---	---

4/7/88

COMPARATIVE LUNG MORTALITY RISKS of
VERMONT and NEW YORK STATE TALC WORKERS
with at least one year experience at Talc Plant

All Emp >1 yr. LATENCY (Years)	Vermont		New York		New York		New York	
	O/E	SMR	O/E	SMR	O/E	SMR	O/E	SMR
					Ever employed		< one Year	
0-4			0/0.27	---	0/0.42	---	0/0.15	---
5-9			0/0.31	---	0/0.49	---	0/0.18	---
10-14			1/0.45	224	1/0.69	145.0	0/0.24	---
15-19			2/0.60	331	2/0.98	205.0	0/0.38	---
20-24			3/0.79	378	8/1.29	623*	5/0.50	1000
25-29			0/0.65	---	1/1.09	92.0	1/0.44	227
30+			0/0.04	---	0/0.05	---	0/0.01	---
Total			6/3.11	193	12/5.01	240*	6/1.90	316*
0-9			0/0.58	---	0/0.91	---	0/0.33	---
10-19			3/1.05	285	3/1.67	180	0/0.62	---
20-29			3/1.44	208	9/2.38	378*	6/0.94	638*
30+			0/0.04	---	0/0.05	---	0/0.01	---
Total			6/3.11	193	12/5.01	240*	6/1.90	316*
0-4			0/0.27	---	0/0.42	---	0/0.15	---
5-14			1/0.76	132	1/1.18	85	0/0.42	---
15-24			5/1.39	360*	10/2.27	441*	5/0.88	568*
25+			0/0.69	---	1/1.14	87	1/0.45	222
Total			6/3.11	193	12/5.01	240*	6/1.90	316*

4/7/88

COMPARATIVE LUNG MORTALITY RISKS of
VERMONT and NEW YORK STATE TALC WORKERS
with at least one year experience at Talc Plant

		Vermont		New York	
		O/E	SMR	O/E	SMR
All Causes	Emp >1	44/37.15	118.0	64/49.83	128
All Cancers	Emp >1			15/9.55	157
Lung Cancer	Emp >1	6/3.61	163	6/3.11	193
NFRD	Emp >1	11/1.79	615	6/1.61	372
Pneumonia/Influ	Emp >1	0/1.89	000	1/0.9	109
All Causes	Millers			20/21.74	92
All Causes	Miners			31/16.76	185
All Causes	Others			13/11.33	115
All Cancers	Millers			3/4.23	71
All Cancers	Miners			10/3.23	310
All Cancers	Others			2/2.09	96
Lung Cancer	Millers	2/1.96	102	1/1.41	71
Lung Cancer	Miners	5/1.15	435	5/1.09	460
Lung Cancer	Others	0/0.55	---	0/0.61	---
NFRD	Millers	7/1.89	787	2/0.74	270
NFRD	Miners	2/0.56	357	2/0.49	408
NFRD	Others	2/0.34	588	2/0.38	526
4/7/88	Bold =	p < 0.05			
Pneumonia/Influ	Millers	0/1.83	000		
Pneumonia/Influ	Miners	0/1.67	000		
Pneumonia/Influ	Others	0/1.39	000		

Standardized Mortality Ratios		
	Vermont	New York
Lung Cancer		
Millers	102	71
Miners	435	460
Others	---	---
NFRD		
Millers	787	270
Miners	357	408
Others	588	526

**NON-INFECTIOUS, NON-
MALIGNANT
RESPIRATORY DISEASE**

	NEW YORK	
VERMONT		
Observed/Expected		
Miller	2/0.74	7/0.89
Miners	2/0.49	2/0.56
Others	2/0.38	2/0.34
 SMR		
Millers	270	787
Miners	408	357
Others	526	588

with death certificates coded according to the seventh revision of the ICD. This report bases the SMRs on the U.S. rates.

The New York State study reports lung cancer as their measure of malignant respiratory disease and NNRD (non-infectious, non-neoplastic respiratory disease) as their measure of non-malignant respiratory disease. The Vermont State study reports respiratory cancer as their measure of malignant respiratory disease and ONMRD (other non-malignant respiratory disease) as their measure of non-malignant respiratory disease. Both NNRD and ONMRD are terms for total non-malignant respiratory disease, excluding influenza and pneumonia. We have used the labels of lung cancer and NNRD to represent the malignant and non-malignant respiratory disease measures.

Twelve of the thirteen respiratory cancers among the New York State talc workers were lung cancers. The thirteenth case was a man whose five years at the plant included three months as a laborer/oiler in the talc mill and ended with death from mediastinal cancer. Re-analysis of the New York State data as respiratory cancer rather than lung cancer would have reduced the SMR estimates by about 5% but not have altered the comparison between the miners and millers. Both the

New York and the Vermont data are compared against U.S. mortality rates.

The Vermont data included persons with experience in both the mine and the mill in each category; the New York data separated them out. There were only 34 such New York workers with experience in both the mine and the mill. Less than 0.1 lung cancer and less than 0.1 NNRD deaths were expected among them, and none were observed. Including this group among the miners and the millers of New York State would not have affected the results.

Studies of both cohorts lack full information on smoking history. Each indicates that most of the lung cancer cases were known to be cigarette smokers, but data on smoking appears to be inadequate for both cohorts. There is no evidence that miners and millers differ in their smoking habits. Thus, it is unlikely that the differences observed in these comparisons could be due to differences in smoking between groups.

The mortality of the experienced employees of the New York and Vermont cohort who worked other than in the mine or the mill for a year were also examined. There were no lung cancer deaths. Each group had two NNRD deaths, yielding non-significant risks of 5.9 for those from Vermont and 5.3 for those from New York.

While the NNRD mortality may be due to dust exposures at the talc plants, the etiology of the lung cancer is less clear. The NIOSH authors² concluded that talc dust was unlikely to be the cause of the respiratory cancer, since the risk was seen only in the miners and not seen among the millers, a group with probable higher dust exposure. Radon daughter measurements in the New York mine do not explain the finding. The presence of a particulate in New York dust and not in Vermont talc dust cannot explain the difference.

The CEOH study¹ had supported the hypothesis of risk from prior employments as the explanation for the lung cancer risk of the New York State talc workers, however, that hypothesis has not been examined for the Vermont talc workers. Further study of both cohorts should be undertaken to explain the mortality patterns seen. The small number of cases in either group will probably be a hindrance to a full and clear explanation. Both cohorts should probably be extended to include later employees and the period of follow-up should be brought more current by at least a decade. A four-fold risk of lung cancer seen in two different studies of talc miners (but not millers) cries for an explanation.

REFERENCES

1. Lamm, S.H., Levine, M.S., Starr, J.A., Turey, S.L.: Analysis of Excess Lung Cancer Risk in Short-Term Employees. *Am. J. Epi.* 127(6):1202-1209 (1988).
2. Selevan, S.G., Dement, J.M., Waggoner, J.K., Froines, J.R.: Mortality Patterns among Miners and Millers of Non-Asbestiform Talc: Preliminary Report. *J. Environ. Path. and Tox.* 2:273-284, 1979.

