

Technical Support Document for the 2004 Effluent Guidelines Program Plan

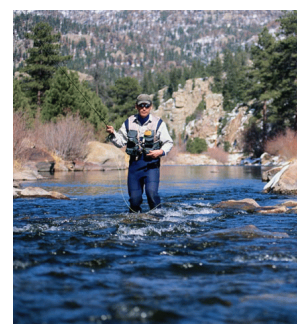
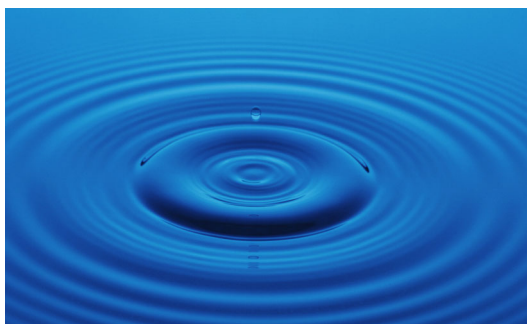
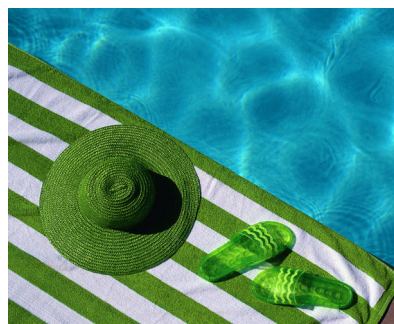

Technical Support Document for the 2004 Effluent Guidelines Program Plan

EPA-821-R-04-014

Mike Leavitt
Administrator

Ben Grumbles
Assistant Administrator, Office of Water

Geoffrey H. Grubbs
Director, Office of Science and Technology

Mary Smith
Director, Engineering and Analysis Division

Tom Wall
Chief, Chemical Engineering Branch

Jan Goodwin
Technical Coordinator

Carey Johnston
Jan Matuszko
Project Managers

U.S. Environmental Protection Agency
Office of Water (4303T)
Engineering and Analysis Division
Office of Science and Technology
Washington, DC 20460
August 2004

ACKNOWLEDGMENTS AND DISCLAIMER

This report has been reviewed and approved for publication by the Engineering and Analysis Division, Office of Science and Technology. This report was prepared with the support of Eastern Research Group, Inc., under the direction and review of the Office of Science and Technology.

Neither the United States government nor any of its employees, contractors, subcontractors, or other employees makes any warranty, expressed or implied, or assumes any legal liability or responsibility for any third party's use of, or the results of such use of, any information, apparatus, product, or process discussed in this report, or represents that its use by such a third party would not infringe on privately owned rights.

TABLE OF CONTENTS

		Page
SECTION 1	BACKGROUND	1-1
	1.1 EPA’s Clean Water Act Program	1-1
	1.2 The Effluent Guidelines Program	1-1
	1.2.1 Best Practicable Control Technology Currently Available (BPT) – CWA Sections 301(b)(1)(A) & 304(b)(1)	1-3
	1.2.2 Best Conventional Pollutant Control Technology (BCT) – CWA Sections 301(b)(2)(E) & 304(b)(4)	1-3
	1.2.3 Best Available Technology Economically Achievable (BAT) – CWA Sections 301(b)(2)(A) & 304(b)(2)	1-3
	1.2.4 New Source Performance Standards (NSPS) – CWA Section 306	1-4
	1.2.5 Pretreatment Standards for Existing Sources (PSES) – CWA Section 307(b)	1-4
	1.2.6 Pretreatment Standards for New Sources (PSNS) – CWA Section 307(c)	1-4
	1.3 Requirements Applicable to Effluent Guidelines Program Planning Efforts	1-4
SECTION 2	PUBLIC COMMENTS ON THE PRELIMINARY EFFLUENT GUIDELINES PROGRAM PLAN FOR 2004/2005	2-1
SECTION 3	ANNUAL REVIEW OF EFFLUENT GUIDELINES PROMULGATED UNDER SECTION 304(b)	3-1
	3.1 Results of 2003 Annual Review	3-1
	3.2 2004 Annual Review	3-1
SECTION 4	DATA SOURCES AND LIMITATIONS	4-1
	4.1 Industry Identification	4-1
	4.1.1 SIC Codes	4-1
	4.1.2 Relationship Between SIC Codes and Point Source Categories	4-1
	4.1.3 Economic Census	4-2
	4.2 Pollutant Loadings Estimates	4-2
	4.2.1 Data from TRI	4-2
	4.2.1.1 Utility of TRI	4-4
	4.2.1.2 Limitations of TRI	4-4
	4.2.2 Data from PCS	4-6
	4.2.2.1 Utility of PCS	4-7
	4.2.2.2 Limitations of PCS	4-8
	4.2.3 Toxic Weighting Factors	4-9
	4.2.4 Calculation of TWPE	4-10
	4.2.4.1 Methodology and Assumptions Used to Calculate TWPE	4-10

TABLE OF CONTENTS (Continued)

		Page
	4.2.4.2 Dioxins and Dioxin-Like Compounds	4-11
	4.2.4.3 Polycyclic Aromatic Compounds (PACs)	4-15
4.3	Impaired Waters Analysis	4-17
	4.3.1 Data Gaps and Limitations in Estimating Impairment Analysis	4-19
4.4	Nutrients Analysis	4-19
4.5	References	4-20
SECTION 5	EXISTING INDUSTRY REVIEW	5-1
5.1	Organization of this Section	5-1
5.2	Group I Industries	5-4
5.3	Group II Industries	5-4
	5.3.1 Inorganic Chemicals (Part 415)	5-4
	5.3.1.1 Industry Description	5-5
	5.3.1.2 Regulatory Background	5-7
	5.3.1.3 Wastewater Characterization	5-9
	5.3.1.4 Treatment Technologies	5-13
	5.3.1.5 Conclusions	5-15
	5.3.1.6 References	5-16
	5.3.2 Nonferrous Metals Manufacturing (Part 421)	5-16
	5.3.2.1 Industry Description	5-17
	5.3.2.2 Regulatory Background	5-20
	5.3.2.3 Wastewater Characterization	5-21
	5.3.2.4 Treatment Technologies	5-24
	5.3.2.5 Conclusions	5-26
	5.3.2.6 References	5-27
5.4	Group III Industries	5-27
	5.4.1 Fertilizer and Phosphate Manufacturing (Parts 418 and 422)	5-27
	5.4.1.1 Industry Description	5-28
	5.4.1.2 Regulatory Background	5-33
	5.4.1.3 Wastewater Characteristics and Pollutant Sources	5-36
	5.4.1.4 Pollutant Prevention and Treatment Technology	5-38
	5.4.1.5 Industry Trends	5-39
	5.4.1.6 Stakeholder and EPA Regional Issues	5-39
	5.4.1.7 Conclusions	5-40
	5.4.1.8 References	5-40
	5.4.2 Ore Mining and Dressing	5-41
	5.4.2.1 Industry Description	5-41
	5.4.2.2 Regulatory Background	5-43
	5.4.2.3 Wastewater Characteristics	5-45
	5.4.2.4 Pollution Prevention and Treatment Technology	5-54
	5.4.2.5 Industry Trends	5-55

TABLE OF CONTENTS (Continued)

	Page
5.4.2.6 Stakeholder and EPA Regional Issues	5-55
5.4.2.7 Conclusions	5-56
5.4.2.8 References	5-56
5.4.3 Pulp, Paper, and Paperboard Phase II	5-57
5.4.3.1 Industry Description	5-57
5.4.3.2 Regulatory Background	5-61
5.4.3.3 Wastewater Characteristics and Pollutant Sources . . .	5-63
5.4.3.4 Pollution Prevention and Treatment Technology	5-71
5.4.3.5 Industry Trends	5-72
5.4.3.6 Stakeholder and Regional EPA Issues	5-72
5.4.3.7 Conclusions	5-72
5.4.3.8 References	5-73
5.4.4 Steam Electric	5-73
5.4.4.1 Industry Description	5-73
5.4.4.2 Regulatory Background	5-74
5.4.4.3 Wastewater Characteristics and Pollutant Sources . . .	5-77
5.4.4.4 Pollutant Prevention and Treatment Technology	5-83
5.4.4.5 Industry Trends	5-84
5.4.4.6 Stakeholder and Regional EPA Issues	5-85
5.4.4.7 Conclusions	5-86
5.4.4.8 References	5-87
5.4.5 Textile Mills	5-87
5.4.5.1 Industry Description	5-87
5.4.5.2 Regulatory Background	5-90
5.4.5.3 Wastewater Characteristics and Pollutant Sources . . .	5-92
5.4.5.4 Pollutant Prevention and Treatment Technology . . .	5-100
5.4.5.5 Industry Trends	5-102
5.4.5.6 Stakeholder and EPA Regional Issues	5-103
5.4.5.7 Conclusions	5-103
5.4.5.8 References	5-104
5.4.6 Timber Products Processing Point Source Category	5-105
5.4.6.1 Industry Description	5-105
5.4.6.2 Regulatory Background	5-107
5.4.6.3 Wastewater Characteristics and Pollutant Sources . .	5-112
5.4.6.4 Pollution Prevention and Treatment Technology . . .	5-120
5.4.6.5 Industry Trends	5-121
5.4.6.6 Stakeholder and EPA Regional Issues	5-121
5.4.6.7 Conclusions	5-123
5.4.6.8 References	5-124
5.5 Group IV Industries	5-125
5.5.1 Canned and Preserved Fruits and Vegetables Processing (Part 407)	5-125
5.5.1.1 Industry Description	5-125

TABLE OF CONTENTS (Continued)

	Page
5.5.1.2 Regulatory Background	5-126
5.5.1.3 Wastewater Characteristics and Pollutant Sources . .	5-127
5.5.1.4 Treatment Technology and Pollution Prevention . . .	5-131
5.5.1.5 Industry Trends	5-131
5.5.1.6 Stakeholder and EPA Regional Issues	5-132
5.5.1.7 Potential Additional Subcategories	5-134
5.5.1.8 Conclusions	5-138
5.5.1.9 References	5-138
5.5.2 Canned and Preserved Seafood Processing (Part 408)	5-138
5.5.2.1 Industry Description	5-138
5.5.2.2 Regulatory Background	5-139
5.5.2.3 Wastewater Characteristics and Pollutant Sources . .	5-140
5.5.2.4 Treatment Technology and Pollution Prevention . . .	5-144
5.5.2.5 Industry Trends	5-144
5.5.2.6 Stakeholder and EPA Regional Issues	5-145
5.5.2.7 Conclusions	5-147
5.5.2.8 References	5-147
5.5.3 Coal Mining (Part 434)	5-147
5.5.3.1 Industry Description	5-148
5.5.3.2 Regulatory Background	5-149
5.5.3.3 Wastewater Characteristics and Pollutant Sources . .	5-151
5.5.3.4 Treatment Technology and Pollution Prevention . . .	5-154
5.5.3.5 Industry Trends	5-154
5.5.3.6 Stakeholder and EPA Regional Issues	5-156
5.5.3.7 Conclusions	5-157
5.5.4 Coil Coating (Part 465)	5-157
5.5.4.1 Industry Description	5-157
5.5.4.2 Regulatory Background	5-158
5.5.4.3 Wastewater Characterization and Pollutant Sources .	5-161
5.5.4.4 Treatment Technology and Pollution Prevention . . .	5-163
5.5.4.5 Industry Trends	5-164
5.5.4.6 Stakeholder and Regional Issues	5-165
5.5.4.7 Conclusions	5-166
5.5.5 Dairy Products Processing (Part 405)	5-167
5.5.5.1 Industry Description	5-167
5.5.5.2 Regulatory Background	5-168
5.5.5.3 Wastewater Characteristics and Pollutant Sources . .	5-170
5.5.5.4 Treatment Technology and Pollution Prevention . . .	5-173
5.5.5.5 Industry Trends	5-174
5.5.5.6 Stakeholder and EPA Regional Issues	5-175
5.5.5.7 Conclusions	5-176
5.5.5.8 References	5-176
5.5.6 Electrical and Electronic Components (Part 469)	5-176

TABLE OF CONTENTS (Continued)

	Page
5.5.6.1 Industry Description	5-177
5.5.6.2 Regulatory Background	5-178
5.5.6.3 Wastewater Characteristics and Pollutant Sources . .	5-181
5.5.6.4 Treatment Technology and Pollution Prevention . . .	5-185
5.5.6.5 Industry Trends	5-185
5.5.6.6 Stakeholder and EPA Regional Issues	5-186
5.5.6.7 Conclusions	5-187
5.5.6.8 References	5-187
5.5.7 Metal Molding and Casting (Part 464)	5-189
5.5.7.1 Industry Description	5-189
5.5.7.2 Regulatory Background	5-189
5.5.7.3 Wastewater Characteristics and Pollutant Sources . .	5-191
5.5.7.4 Treatment Technology and Pollution Prevention . . .	5-195
5.5.7.5 Industry Trends	5-195
5.5.7.6 Stakeholder and EPA Regional Issues	5-196
5.5.7.7 Conclusions	5-199
5.5.8 Mineral Mining and Processing (Part 436)	5-199
5.5.8.1 Industry Description	5-200
5.5.8.2 Regulatory Background	5-203
5.5.8.3 Wastewater Characteristics and Pollutant Sources . .	5-206
5.5.8.4 Treatment Technology and Pollution Prevention . . .	5-209
5.5.8.5 Industry Trends	5-210
5.5.8.6 Stakeholder and EPA Regional Issues	5-212
5.5.8.7 Conclusions	5-213
5.5.9 Oil and Gas Extraction (40 CFR Part 435)	5-213
5.5.9.1 Industry Description	5-213
5.5.9.2 Regulatory Background	5-216
5.5.9.3 Wastewater Characteristics and Pollutant Sources . .	5-218
5.5.9.4 Pollutants of Concern Identified	5-219
5.5.9.5 Offshore Subcategory (Subpart A)	5-220
5.5.9.6 Coastal Subcategory (Subpart D)	5-225
5.5.9.7 Coal Bed Methane Extraction	5-232
5.5.9.8 References	5-245
5.6 Group V Industries	5-245
5.6.1 Metal Products and Machinery, Metal Finishing, and Electroplating (Parts 438, 413, and 433)	5-249
5.6.1.1 Background	5-249
5.6.1.2 Public Comments	5-250
5.6.1.3 EPA Review of Available Data	5-250
5.6.1.4 Conclusions	5-248
5.6.2 Pulp and Paperboard (Part 430)	5-252
5.6.2.1 Technology Basis for Phase I	5-252
5.7 Group VI Industries	5-253

TABLE OF CONTENTS (Continued)

	Page
SECTION 6	
ORGANIC CHEMICALS, PLASTICS, AND SYNTHETIC FIBERS	
DETAILED REVIEW	6-1
6.1 Introduction	6-1
6.2 Data Sources	6-2
6.2.1 Toxic Release Inventory (TRI)	6-2
6.2.1.1 Facility-Specific Verification of TRI Data	6-4
6.2.1.2 Data Submitted with Comments	6-4
6.2.1.3 Correction for PCBs and Pesticides	6-4
6.2.2 Permit Compliance System (PCS)	6-5
6.2.2.1 Data Submitted with Comments	6-5
6.2.2.2 Correction for PCBs and Pesticides	6-6
6.2.3 Economic Census	6-6
6.2.4 The Chlorine Chemistry Council	6-6
6.2.5 The Vinyl Institute	6-7
6.2.6 Office of Solid Waste Chlorinated Aliphatics Rule	6-7
6.2.7 Office of Air and Radiation NESHAPs Rule for Mercury Cell Chlor-Alkali Plants	6-8
6.2.8 Other Data Sources	6-8
6.3 General Industry Profile and Identification of Focus Industries	6-9
6.3.1 General Overview of the OCPSF Category	6-9
6.3.2 OCPSF Manufacturing Processes	6-12
6.3.3 General Wastewater Characteristics and Treatment	6-13
6.3.3.1 General Wastewater Characteristics	6-13
6.3.3.2 General Wastewater Treatment	6-16
6.3.4 Focus Industry Identification and SIC Code Analysis	6-17
6.3.4.1 Focus Industry Identification	6-17
6.3.4.2 No Further Consideration of SIC Codes 2823 and 2824: Fiber Manufacturers	6-18
6.3.4.3 Decision for No Further Investigation	6-22
6.4 Current Effluent Limitations Guidelines and Standards	6-22
6.5 Other Regulations Affecting OCPSF Facilities	6-24
6.5.1 Resource Conservation and Recovery Act (RCRA)	6-24
6.5.2 Comprehensive Environmental Response, Compensation, and Liability Act (CERCLA)	6-25
6.5.3 Clean Air Act (CAA)	6-25
6.5.3.1 NESHAPs Program	6-26
6.5.3.2 NSPS	6-27
6.5.3.3 Consolidated Air Rule (CAR)	6-27
6.5.3.4 State Implementation Plans (SIP)	6-27
6.5.3.5 New Source Review	6-27
6.5.3.6 Title VI Stratospheric Ozone Protection	6-28
6.5.4 Toxic Substances Control Act (TSCA)	6-28

TABLE OF CONTENTS (Continued)

		Page
	6.5.5 Emergency Planning and Community Right-To-Know Act (EPCRA)	6-29
	6.5.6 Pending and Proposed Regulatory Requirements	6-29
6.6	Focus Group 1: Coal Tar Refiners	6-29
	6.6.1 Facilities	6-29
	6.6.2 Process Description and Wastewater Sources	6-30
	6.6.3 Pollutants of Concern	6-32
	6.6.3.1 TRI Data	6-32
	6.6.3.2 PCS Data	6-33
	6.6.4 Wastewater Treatment	6-35
	6.6.5 Industry Trends	6-35
	6.6.6 Conclusions	6-36
6.7	Focus Group 2 - Aniline Dischargers	6-36
	6.7.1 Facilities	6-36
	6.7.2 Process Description and Wastewater Sources	6-38
	6.7.2.1 Aniline Production	6-38
	6.7.2.2 Azo Dye Manufacturing	6-41
	6.7.3 Pollutants of Concern	6-43
	6.7.4 Wastewater Treatment	6-44
	6.7.5 Conclusions	6-46
6.8	Focus Group 3: Dioxin Dischargers	6-46
	6.8.1 Facilities	6-47
	6.8.2 Process Descriptions	6-51
	6.8.2.1 Chlor-Alkali	6-51
	6.8.2.2 Ethylene Dichloride and Vinyl Chloride Monomer ..	6-55
	6.8.2.3 Polyvinyl Chloride	6-57
	6.8.3 Wastewater Sources	6-58
	6.8.4 Pollutants of Concern	6-60
	6.8.4.1 Pollutants of Concern by Product Group	6-60
	6.8.4.2 Dioxin as a Pollutant of Concern	6-63
	6.8.5 Comparison of Dioxin Release Data for OCPSF Focus Group 3	6-71
	6.8.6 Wastewater Treatment in Place	6-72
	6.8.6.1 Chlor-Alkali	6-78
	6.8.6.2 Integrated Chlor-Alkali/EDC/VCM	6-78
	6.8.6.3 EDC/VCM	6-78
	6.8.7 Industry Trends	6-78
	6.8.7.1 Dioxin Discharge Trends	6-78
	6.8.7.2 Chlorine Industry Trends	6-80
	6.8.8 Conclusions	6-80
6.9	Control of Dioxin in Wastewater	6-83
	6.9.1 Treatment Technologies for Control of Dioxin in Wastewater	6-83

TABLE OF CONTENTS (Continued)

		Page
	6.9.1.1 Pollution Prevention	6-83
	6.9.1.2 In-Process Wastewater Treatment	6-83
	6.9.1.3 End-of-Pipe Wastewater Treatment	6-84
	6.9.2 Summary of Available Treatment Cost Data and Justification for Not Estimating Costs	6-84
6.10	Chemical Formulators, Packagers, and Repackagers	6-85
	6.10.1 CFPR Industry Description	6-85
	6.10.2 Process Descriptions and Wastewater Sources	6-87
	6.10.2.1 CFPR Processes	6-87
	6.10.2.2 CFPR Process Wastewater	6-88
	6.10.3 Pollutants of Concern	6-89
	6.10.3.1 PCS and TRI Data for the CFPR Industry	6-89
	6.10.3.2 Pollutants of Concern for SIC Code 2842	6-91
	6.10.3.3 Pollutants of Concern for SIC Code 2844	6-91
	6.10.3.4 Pollutants of Concern for SIC Code 2891	6-91
	6.10.3.5 Pollutants of Concern for SIC Code 2899	6-92
	6.10.3.6 Total TWPE for CFPR Operations	6-92
	6.10.4 Wastewater Treatment/Best Management Practices	6-93
	6.10.4.1 CFPR Wastewater Treatment	6-93
	6.10.4.2 Permit Review Summary	6-94
	6.10.5 Conclusions	6-95
6.11	References	6-95
SECTION 7	PETROLEUM REFINING	7-1
	7.1 Introduction	7-1
	7.2 Data Sources	7-2
	7.2.1 Toxic Release Inventory (TRI)	7-2
	7.2.1.1 Identification of Petroleum Refineries Operating in 2000	7-4
	7.2.1.2 Refinery-Specific Verification of TRI Data	7-4
	7.2.1.3 Meetings with Representatives from Refinery and Trade Associations	7-6
	7.2.1.4 Comments Received in Response to the Federal Register Notice of the 2004/2005 Preliminary Effluent Guidelines Program Plan	7-6
	7.2.2 Permit Compliance System (PCS)	7-7
	7.2.3 The U.S. Economic Census	7-8
	7.2.4 Data Sources Specific to the Petroleum Refining Industry	7-8
7.3	Industry Description	7-9
	7.3.1 Number of Refineries	7-9
	7.3.2 Discharge Status for Petroleum Refineries	7-10
	7.3.3 Overview of Refinery Operations	7-10
	7.3.3.1 Crude Petroleum Processing	7-11

TABLE OF CONTENTS (Continued)

		Page
	7.3.3.2 Refining of Petroleum Fractions - Cracking, Coking, Hydrotreating/Hydroprocessing, Alkylation, Polymerization, and Isomerization	7-11
	7.3.3.3 Refining of Petroleum Fractions - Catalytic Reforming and Reformer Catalyst Regeneration	7-13
	7.3.3.4 Refining of Petroleum Product Properties	7-17
	7.3.3.5 Supporting Operations at Petroleum Refineries	7-17
7.4	Regulatory Background	7-18
	7.4.1 Effluent Guidelines History	7-18
	7.4.2 Subcategorization and Applicability	7-18
	7.4.3 Technical Basis of Regulation	7-20
	7.4.4 Regulated Pollutants	7-20
	7.4.5 Other Regulations Affecting Petroleum Refineries	7-21
	7.4.5.1 RCRA	7-21
	7.4.5.2 CAA National Emission Standards for Hazardous Air Pollutants (NESHAPs)	7-22
	7.4.5.3 Other CWA Requirements	7-22
7.5	Wastewater Characterization	7-23
	7.5.1 Wastewater Sources	7-23
	7.5.2 Discharge Volumes	7-25
	7.5.2.1 Discharge Volumes from the <i>1996 Preliminary Data Summary</i>	7-25
	7.5.2.2 Discharge Volumes from All Refineries Reported to 2000 PCS	7-25
	7.5.3 Pollutant Loadings	7-25
	7.5.3.1 Pollutant Loadings Calculated Using TRI Data	7-26
	7.5.3.2 Pollutant Loadings Calculated Using PCS Data	7-27
	7.5.4 Treatment In Place	7-28
7.6	Polycyclic Aromatic Compounds	7-29
	7.6.1 Identification and Description of PACs	7-30
	7.6.2 Estimation of TWPE	7-31
	7.6.3 Sources at Petroleum Refineries	7-31
	7.6.4 Reported PAC Discharges	7-33
	7.6.4.1 TRI Discharges	7-33
	7.6.4.2 PCS Discharges	7-33
	7.6.4.3 Data Provided in Comments Regarding Preliminary Plan	7-36
	7.6.5 Further Analysis of PACs	7-37
	7.6.6 PAC Control Technologies	7-40
	7.6.7 Detailed Study Findings on PACs	7-42
7.7	Dioxins	7-43
	7.7.1 Identification and Description of Dioxins	7-43
	7.7.2 Estimation of TWPE	7-44

TABLE OF CONTENTS (Continued)

	Page
7.7.3	Dioxin Sources at Petroleum Refineries 7-45
7.7.4	Reported Dioxin Discharges 7-45
	7.7.4.1 TRI Discharges 7-45
	7.7.4.2 PCS Discharges 7-47
	7.7.4.3 In-Plant Monitoring 7-47
	7.7.4.4 Industry Comments About Dioxins 7-50
7.7.5	Compilation and Discussion of Measured Effluent Dioxin Concentrations 7-50
7.7.6	Dioxin Control Technologies 7-58
7.7.7	Detailed Study Findings for Dioxins 7-59
7.8	Metals 7-63
	7.8.1 Identification and Description of the Metals Discharged in Petroleum Refinery Wastewater 7-63
	7.8.2 Sources of Metals at the Petroleum Refinery 7-63
	7.8.3 Reported Metal Discharges 7-64
	7.8.3.1 Mass Discharges: TRI and PCS 7-64
	7.8.3.2 Additional Metals Data (Concentrations) 7-66
	7.8.4 Metals Control Technologies 7-70
	7.8.5 Detailed Study Findings for Metals 7-70
7.9	Conventional and Nonconventional Pollutants 7-72
	7.9.1 Reported Conventional and Nonconventional Pollutant Discharges 7-72
	7.9.1.1 Mass Discharges: PCS 7-72
	7.9.1.2 Conventional and Nonconventional Pollutant Concentrations 7-73
	7.9.2 Detailed Study Findings for Conventional and Other Nonconventional Pollutants 7-76
7.10	Pollution Control 7-77
7.11	Petroleum Refining References 7-78
7.12	Petroleum Bulk Stations and Terminals 7-81
	7.12.1 Introduction 7-81
	7.12.2 Data Sources 7-82
	7.12.2.1 Toxic Release Inventory 7-82
	7.12.2.2 Permit Compliance System 7-84
	7.12.2.3 Other Data Sources 7-85
	7.12.3 Industry Description 7-86
	7.12.3.1 Industry Groups 7-86
	7.12.3.2 Industry Statistics 7-87
	7.12.3.3 Discharge Status 7-88
	7.12.3.4 Overview of Operations and Potential Wastewater Sources 7-89
	7.12.4 Regulatory Background 7-96
	7.12.4.1 Clean Water Act 7-97

TABLE OF CONTENTS (Continued)

		Page
	7.12.4.2 Clean Air Act	7-98
	7.12.4.3 Resource Conservation and Recovery Act ...	7-99
	7.12.4.4 Emergency Planning and Community Right-to-Know Act	7-102
	7.12.4.5 Safe Drinking Water Act	7-103
	7.12.4.6 Regional and State Programs	7-103
	7.12.5 Wastewater Characterization	7-111
	7.12.5.1 TRI Data	7-111
	7.12.5.2 PCS Data	7-111
	7.12.5.3 Stormwater Contributions to TRI and PCS Data	7-112
	7.12.5.4 Wastewater Handling	7-113
	7.12.6 Pollution Prevention Practices	7-114
	7.12.6.1 Stormwater Pollution Prevention Practices ..	7-115
	7.12.6.2 Minimizing Generation of Wastewater	7-117
	7.12.6.3 Pollution Prevention Practices for Reducing Other Sources of Wastewater	7-124
	7.12.6.4 Conclusions	7-125
	7.12.7 PBST References	7-126
SECTION 8	NUTRIENT ANALYSIS	8-1
	8.1 Introduction	8-1
	8.2 Reference Conditions	8-1
	8.3 Decay Coefficients	8-2
	8.4 Methodology for Developing Total Nitrogen and Total Phosphorous Loads	8-3
	8.4.1 Total Nitrogen Load	8-3
	8.4.2 Total Phosphorous Load	8-5
	8.5 Stream Dilution Modeling	8-6
	8.6 Results	8-7
	8.6.1 Petroleum Refining	8-7
	8.6.2 OCPSF	8-8
	8.7 References	8-9
SECTION 9	INDUSTRIES IDENTIFIED AS NEW BY COMMENTERS	9-1
	9.1 Airport Deicing Operations	9-1
	9.2 Drinking Water Supply & Treatment	9-2

LIST OF TABLES

		Page
2-1	Comments on Preliminary Effluent Guidelines Program Plan for 2004/2005 EPA Docket Number: OW-2003-0074	2-1
4-1	Dioxins and Their Toxic Equivalency Factors	4-13
4-2	Dioxins and Their Toxic Weighting Factors	4-14
4-3	Definition of Polycyclic Aromatic Compounds	4-15
5-1	Industries Covered by National Clean Water Industrial Regulations	5-2
5-2	Number of Facilities in Inorganic Chemicals Manufacturing Industry	5-6
5-3	Number of Facilities by Discharge Type and SIC Code	5-6
5-4	Reserved Subparts in 40 CFR Part 415	5-8
5-5	Subparts in 40 CFR Part 415 Requiring No Discharge at BPT	5-8
5-6	Regulated Pollutants/Parameters by Subpart in 40 CFR Part 415	5-9
5-7	2000 TRI Top Pollutants Discharged by the Inorganic Chemicals Manufacturing Industry	5-10
5-8	2000 PCS Top Pollutants Discharged by the Inorganic Chemicals Manufacturing Industry	5-11
5-9	1992 and 2000 Wastewater Flows by SIC Code	5-12
5-10	Pollutants of Concern from 2000 TRI Data (Direct and Indirect Dischargers)	5-12
5-11	Pollutants of Concern from 2000 PCS Data (Direct Dischargers)	5-13
5-12	Wastewater Treatment Operations Reported By Inorganic Chemicals Manufacturing Facilities, TRI Reporting Year 2000	5-14
5-13	SIC Codes and Subcategories in Part 421	5-17
5-14	Number of Operating Facilities, By Year and Data Source	5-19
5-15	Wastewater Discharge Status Reported in <i>TRIReleases2000</i>	5-20

LIST OF TABLES (Continued)

		Page
5-16	Top Pollutants Discharged by the NFM Manufacturing Industry	5-22
5-17	Pollutants of Concern Identified in <i>TRI Releases 2000</i> (Direct and Indirect Dischargers)	5-23
5-18	Pollutants of Concern Identified in PCS Database (Direct Dischargers)	5-24
5-19	NFM Manufacturing Category Pollutant Reductions	5-25
5-20	Wastewater Treatment Operations Reported By NFM Manufacturing Facilities, TRI Reporting Year 2000	5-25
5-21	Subcategories in the Fertilizer Manufacturing Point Source Category (Part 418)	5-28
5-22	Subcategories in the Phosphate Manufacturing Point Source Category (Part 422)	5-29
5-23	Review of Top Fertilizer and Phosphate Dischargers Reporting SIC 2874 as Primary SIC Code	5-30
5-24	Number of Fertilizer and Phosphate Facilities	5-33
5-25	Pollutants Regulated by Existing Fertilizer and Phosphate ELGS	5-34
5-26	2000 Wastewater Flows for Fertilizer and Phosphate Facilities	5-36
5-27	Fertilizer and Phosphate Pollutant Discharges Reported by Major Facilities to PCS for 2000	5-37
5-28	Fertilizer and Phosphate Chemical Releases to Surface Water Reported to TRI for 2000	5-37
5-29	Wastewater Treatment Operations Reported By Fertilizer and Phosphate Manufacturing Facilities, TRI Reporting Year 2000	5-38
5-30	Number of Ore Mining and Dressing Facilities	5-42
5-31	Number of Ore Mining and Dressing Facilities by Discharge Type (TRI 2000)	5-43
5-32	Ore Mining and Dressing Pollutants Regulated by Existing Effluent Limitations Guidelines and Standards	5-44

LIST OF TABLES (Continued)

		Page
5-33	2000 Wastewater Flows for Ore Mining and Dressing Facilities	5-45
5-34	Ore Mining and Dressing Chemical Releases to Surface Water Reported to TRI for 2000	5-46
5-35	Ore Mining and Dressing Pollutant Discharges Reported to PCS for 2000 . .	5-47
5-36	Ore Mining and Dressing Top Pollutants Reported to TRI and PCS for 2000 That Are Not Regulated Under 40 CFR Part 440	5-50
5-37	Toxic Metals in Ore Mining Wastewater	5-51
5-38	Ore Mining and Dressing Stormwater Discharges Reported to TRI for 2000	5-52
5-39	Wastewater Treatment Operations Reported By Ore Mining and Dressing Facilities, TRI Reporting Year 2000	5-54
5-40	Comparison of Ore Mining and Dressing Facilities in 1982 and 2000	5-55
5-41	Number of Pulp, Paper, and Paperboard Establishments	5-59
5-42	Pulp and Paper Mills Reporting to TRI for Reporting Year 2000	5-60
5-43	Pulp and Paper Mills with Data in PCS	5-60
5-44	Phase II Mills	5-61
5-45	ELGS for Pulp, Paper, and Paperboard Phase II Subcategories (Part 430) . . .	5-62
5-46	2000 Wastewater Flows for Phase II Mills (All SIC Codes)	5-63
5-47	Pulp and Paper Phase II Chemical Releases Reported to TRI for 2000	5-65
5-48	Pulp and Paper Phase II Chemical Releases Reported to TRI for 2000 Without PACs or Dioxins	5-65
5-49	Pulp and Paper Phase II PCS Pollutant Discharges Reported for PCS for 2000	5-66
5-50	Comparison of Analytes Detected in Treated Wastewater (Final Effluent) . .	5-67
5-51	Phase II Mills Reporting Releases of PACs for TRI Reporting Year 2000 . .	5-68

LIST OF TABLES (Continued)

		Page
5-52	Phase II Mills Reporting Releases of Dioxin and Dioxin-Like Compounds to TRI for Reporting Year 2000	5-70
5-53	Wastewater Treatment Operations Reported by Phase II Mills, TRI Reporting Year 2000	5-71
5-54	Trends in U.S. Papermaking Industry (Pulp, Paper, and Converted Products)	5-72
5-55	Number of Steam Electric Facilities	5-74
5-56	Steam Electric Pollutants Regulated by ELGS	5-76
5-57	Sources of Process Wastewater in Steam Electric Facilities	5-77
5-58	2000 Wastewater Flows for Steam Electric Facilities	5-78
5-59	Steam Electric Chemical Releases to Surface Water Reported to TRI for 2000	5-79
5-60	Pollutant Discharges Reported by Major Steam Electric Facilities to PCS for 2000	5-80
5-61	Five Highest Parameter Loadings (as Measured by TWPE) Reported to PCS in 1992 and 2000	5-82
5-62	Wastewater Treatment Operations Reported By Steam Electric Facilities, TRI Reporting Year 2000	5-84
5-63	Comparison of Industry Statistics	5-85
5-64	Textile Mills Subcategories	5-87
5-65	Number of Textile Mills	5-88
5-66	Number of Textile Mills by Discharge Type (TRI 2000)	5-89
5-67	Pollutants Regulated by Existing Textile Mill ELGS	5-92
5-68	2000 Wastewater Flows for Textile Mills	5-93
5-69	Textile Mill Chemical Releases to Surface Water Reported to TRI for 2000	5-95

LIST OF TABLES (Continued)

	Page
5-70	Textile Mill Pollutant Discharges Reported to PCS for 2000 5-96
5-71	Textile Mill Pollutant Discharges Reported in 1996 Preliminary Study 5-96
5-72	Eight Highest Chemical Releases Reported to TRI in 1992 and 2000 5-97
5-73	Five Highest Parameter Loadings Reported to PCS in 1994 and 2000 5-98
5-74	Sources of Process Wastewater in Textile Manufacturing 5-99
5-75	Wastewater Treatment Operations Reported By Textile Mills, TRI Reporting Year 2000 5-101
5-76	Comparison of Industry Statistics 5-103
5-77	Timber Products Processing SIC Code Descriptions 5-105
5-78	Number of Facilities in Timber Products Processing SIC Codes 5-106
5-79	Number of Timber Products Processing Facilities by Discharge Type (TRI 2000) 5-107
5-80	Pollutants Regulated by Existing Timber Products Processing ELGS 5-108
5-81	Summary of Technology Basis of Existing Timber Products ELGS 5-110
5-82	Timber Products Wastewater Flows Reported to PCS for 2000 5-113
5-83	Timber Products Processing Pollutant Discharges Reported to PCS for 2000 5-114
5-84	Timber Products Processing Pollutant Releases to Surface Water Reported to TRI for 2000 5-116
5-85	Stormwater Discharges of Pollutants Accounting for 90 Percent of Unweighted Pounds of Wood Preserving Pollutant Loads 5-118
5-86	Stormwater Discharges of Pollutant Accounting for 90 Percent of Wood Preserving TWPE 5-118
5-87	Nonstormwater Discharges of Pollutants from Wood Preserving Facilities 5-119

LIST OF TABLES (Continued)

		Page
5-88	Wastewater Treatment Operations Reported By Timber Products Processing Facilities TRI Reporting Year 2000	5-120
5-89	Number of Facilities in Fruits and Vegetable Processing SIC Codes	5-126
5-90	Effluent Guidelines for Canned and Preserved Fruits and Vegetables Processing, Part 407	5-127
5-91	Wastewater Flows in the Canned and Preserved Fruits and Vegetables Processing Industry	5-127
5-92	Sources of Process Wastewater in Canned and Preserved Fruits and Vegetables Processing Industry	5-128
5-93	Pollutant Discharges Reported to PCS and TRI	5-129
5-94	Canned and Preserved Fruits and Vegetables Processing TWPE Reported to PCS Compared to Industries Reporting Highest Discharge	5-130
5-95	Canned and Preserved Fruits and Vegetables Processing TWPE Reported to TRI Compared to Industries Reporting Highest Discharges	5-130
5-96	Water Conservation and Pollution Prevention Alternatives	5-131
5-97	Comparison of 1992 and 1997 Census Data	5-132
5-98	Comparison of 1997 and 2002 U.S. Economic Census Data	5-132
5-99	Number of Facilities in the Canned and Preserved Seafood Processing Category	5-139
5-100	Effluent Guidelines for Canned and Preserved Seafood Processing Part 408	5-141
5-101	Wastewater Flows	5-140
5-102	Pollutant Discharges Reported to PCS and TRI in 2000	5-142
5-103	Canned and Preserved Seafood Processing TWPE Reported to PCS Compared to Industries Reporting 10 Highest Discharges	5-143
5-104	Canned and Preserved Seafood Processing TWPE Reported to TRI Compared to Industries Reporting 10 Highest Dischargers	5-143

LIST OF TABLES (Continued)

		Page
5-105	Water Conservation and Pollution Prevention Alternatives	5-144
5-106	1992 and 1997 Census Data	5-145
5-107	1997 and 2002 Census Data	5-145
5-108	Number of Facilities in the Coal Mining Category	5-149
5-109	Effluent Guidelines for Coal Mining Part 434	5-150
5-110	Catastrophic Precipitation Event Exemption	5-150
5-111	Wastewater Flows for Coal Mining Facilities	5-151
5-112	Sources of Process Wastewater in Coal Mining	5-151
5-113	Pollutant Discharges Reported to PCS and TRI in 2000	5-152
5-114	Coal Mining TWPE Reported to PCS Compared to Industries Reporting 10 Highest Discharges	5-153
5-115	Coal Mining TWPE Reported to TRI Compared to Industries Reporting 10 Highest Discharges	5-153
5-116	1992 and 1997 Census Data	5-155
5-117	Number of U.S. Coal Mining Operations from 1997 to 2002	5-155
5-118	U.S. Coal Production from 1997 to 2000 (in millions of short tons)	5-155
5-119	Number of Facilities	5-158
5-120	Effluent Guidelines for Coil Coating and Canmaking	5-160
5-121	Sources of Process Wastewater in Coil Coating and Canmaking	5-161
5-122	Pollutant Discharges Reported to PCS and TRI	5-162
5-123	Coil Coating TWPE Reported to PCS Compared to Industries Reporting 10 Highest Discharges	5-162
5-124	Coil Coating TWPE Reported to TRI Compared to Industries Reporting 10 Highest Discharges	5-163

LIST OF TABLES (Continued)

	Page
5-125	Water Conservation and Pollution Prevention Alternatives 5-164
5-126	1992 and 1997 Census Data 5-165
5-127	1997 and 2002 Census Data 5-165
5-128	Can Shipments by Category 5-165
5-129	Number of Facilities in the Dairy Products Processing Category 5-168
5-130	Effluent Guidelines for Dairy Products Processing Part 405 5-169
5-131	Wastewater Flows 5-170
5-132	Sources of Process Wastewater in Dairy Products Processing 5-170
5-133	Pollutant Discharges Reported to PCS and TRI 5-171
5-134	Dairy Products Processing TWPE Reported to PCS Compared to Industries Reporting Highest Discharges 5-172
5-135	Dairy Products Processing TWPE Reported to TRI Compared to Industries Reporting Highest Discharges 5-172
5-136	Pollution Prevention Alternatives for Dairy Products Processing 5-174
5-137	1992 and 1997 Census Data 5-175
5-138	1997 and 2002 Census Data 5-175
5-139	Number of Facilities in the Electrical and Electronic Components Category 5-177
5-140	Effluent Guidelines for Semiconductors and Electronic Crystals Manufacturing (Concentration-Based) 5-179
5-141	Effluent Limitations and Standards for Cathode Ray Tubes and Luminescent Materials Manufacturing (Concentration-Based) 5-180
5-142	Wastewater Flows 5-181
5-143	Sources of Process Wastewater in Electrical and Electronic Components Category 5-182

LIST OF TABLES (Continued)

		Page
5-144	Pollutant Discharges Reported to PCS and TRI	5-183
5-145	Electrical and Electronic Components TWPE Reported to PCS Compared to Industries with the 10 Highest Discharges	5-184
5-146	Electrical and Electronic Components TWPE Reported to TRI Compared to Industries with the 10 Highest Discharges	5-184
5-147	Water Conservation and Pollution Prevention Alternatives for the Electrical and Electronic Components Category	5-185
5-148	1992 and 1997 Census Data	5-186
5-149	1997 and 2002 Census Data	5-186
5-150	Copper Discharges Reported to TRI by Electrical and Electronic Component Manufacturing Facilities	5-187
5-151	Copper ¹ Discharge Data in PCS for Electrical and Electronic Component Manufacturing Facilities	5-187
5-152	Number of Facilities in the Metal Molding and Casting Category	5-189
5-153	Effluent Guidelines for Metal Molding and Casting – Continuous Direct Dischargers (kg/kkg)	5-191
5-154	Wastewater Flows in Metal Molding and Casting	5-192
5-155	Sources of Process Wastewater in Metal Molding and Casting	5-192
5-156	Pollutant Discharges Reported to PCS and TRI	5-193
5-157	Metal Molding and Casting TWPE Reported to PCS Compared to Industries Reporting Highest Discharges	5-194
5-158	Metal Molding and Casting TWPE Reported to TRI Compared to Industries Reporting Highest Discharges	5-194
5-159	Water Conservation and Pollution Prevention Alternatives for the Metal Molding and Casting Category	5-195
5-160	1992 and 1997 Census Data	5-196

LIST OF TABLES (Continued)

		Page
5-161	1997 and 2002 Census Data	5-196
5-162	Number of Facilities	5-203
5-163	Effluent Guidelines for Crushed Stone, Construction Sand and Gravel, and Industrial Sand Subcategories of Part 436	5-205
5-164	Effluent Guidelines for Other Subcategories of Part 436	5-205
5-165	Normalized Effluent Guidelines for Subcategories of Part 436	5-206
5-166	Wastewater Flows	5-206
5-167	Process Sources of Wastewater	5-207
5-168	Pollutant Discharges Reported to PCS and TRI	5-208
5-169	Mineral Mining TWPE Reported to PCS Compared to Industries Reporting Highest Discharges	5-208
5-170	Mineral Mining TWPE Reported to TRI Compared to Industries Reporting Highest Discharges	5-209
5-171	Water Conservation and Pollution Prevention Alternatives	5-210
5-172	1992 and 1997 Census Data	5-211
5-173	1997 and 2002 Census Data	5-211
5-174	Number of Facilities in the Oil and Gas Extraction Category	5-214
5-175	Number of Wells Drilled Annually, 1995 - 1997, by Geographic Area	5-215
5-176	Identification of Oil and Gas Extraction Fixed Facilities in the Gulf of Mexico Outer Continental Study	5-215
5-177	Process Wastewater Sources for the Oil and Gas Extraction Industry	5-219
5-178	Pollutant Discharges Reported to PCS and TRI for 2000	5-220
5-179	2000 Discharge Monitoring Report (DMR) Data for the Union Oil Company of California.	5-221

LIST OF TABLES (Continued)

		Page
5-180	Estimated TWPE from Oil and Gas Extraction Facilities in Cook Inlet, AK	5-226
5-181	Current Sources of CBM Production	5-233
5-182	Estimated CBM Industry Pollutant Loadings	5-234
5-183	Effluent Guidelines Recently Established, Revised, or Reviewed	5-246
5-184	Low Ranked Industries Not Identified by Stakeholders	5-254
6-1	OCPSF Subcategories for BPT (40 CFR Part 414)	6-10
6-2	Examples of Chemicals Produced by OCPSF Facilities	6-10
6-3	SIC Codes in OCPSF	6-12
6-4	Examples of Generic OCPSF Processes Identified in the 1987 TDD	6-12
6-5	Examples of Feedstock and End Products Identified in the 1987 TDD	6-13
6-6	Untreated Wastewater Characteristics for Direct and Indirect Dischargers in the OCPSF Category	6-14
6-7	Examples of Pollutants Discharged from the Manufacturing of Certain Products	6-14
6-8	OCPSF Pollutant Load Discharged to Surface Water in 2000 by SIC Code .	6-15
6-9	OCPSF Annual Wastewater Flows by SIC Code as Reported to PCS in 2000	6-15
6-10	Wastewater Treatment Operations Reported by OCPSF Facilities TRI Reporting Year 2000	6-16
6-11	Top Pollutants Reported Discharged in 2000 for the OCPSF Category	6-17
6-12	Facilities in SIC Codes 2823 and 2824 in the 2000 TRI and/or PCS 2000 ...	6-19
6-13	Facilities with Primary SIC Code 2824 in PCS and 2821 in TRI	6-20
6-14	Facilities with Primary SIC Code 2824 in TRI and Other in PCS	6-20

LIST OF TABLES (Continued)

	Page
6-15	Pollutants with Highest TWPE Based on 2000 TRI Data 6-21
6-16	Pollutants with Highest TWPE Based on PCS 2000 Data 6-22
6-17	Summary of Existing Effluent Limitations Guidelines and Pretreatment Standards (40 CFR Part 414) 6-23
6-18	Coal Tar Refiners in the United States 6-30
6-19	PACs Water Discharges Reported to TRI for 2000 and 2001 6-32
6-20	PACs Wastewater Discharges Reported to PCS in 2000 6-33
6-21	Concentrations of PACs Reported to PCS 6-34
6-22	Pollutants of Concern for Coal Tar Refiners 6-34
6-23	Production Trend for Cokemaking and Coal Tar Pitch 6-35
6-24	OCPSF Aniline Dischargers in the United States 6-37
6-25	Aniline Discharges Reported to TRI and PCS in 2000 for SIC Code 2865 . . 6-43
6-26	Aniline Discharges Reported to TRI 6-44
6-27	Pollutants of Concern for Aniline Dischargers 6-44
6-28	Facilities That Discharge Indirectly and Their Respective POTWs 6-45
6-29	OCPSF Dioxin Dischargers in the United States 6-48
6-30	Facilities Reporting Dioxin Discharges to TRI that Manufacture Other Organic Chemicals in the United States 6-50
6-31	Pollutants of Concern for 24 Stand-Alone Chlor-Alkali Manufacturers 6-60
6-32	Pollutants of Concern for Stand-Alone EDC/VCM Manufacturers (No Chlor Alkali) 6-61
6-33	Pollutants of Concern for Integrated Chlor-Alkali and Vinyl Facilities (Manufacturers of Chlor-Alkali and EDC/VCM, May Also Produce PVC) . . 6-62

LIST OF TABLES (Continued)

		Page
6-34	Pollutants of Concern for Stand-Alone Manufacturers of Polyvinyl Chloride	6-62
6-35	Dioxin Releases Reported by OCPSF Facilities to TRI for 2000 and 2001, Adjusted for POTW Removals	6-65
6-36	Dioxin Loads Reported by OCPSF Facilities to PCS for 2000	6-66
6-37	Wastewater Emission Factors and Estimated Releases for PVC-Only and EDC/VCM/PVC Manufacturing Facilities	6-67
6-38	CCC Data for Dioxin Discharges from Facilities Manufacturing Chlorine or Chlorine-Related Products for 2000	6-68
6-39	Dioxin Congeners Detected in Raw Wastewater from EDC/VCM Operations	6-69
6-40	Focus Group 3 Industry Analytical Data on Dioxin in Wastewater	6-70
6-41	Wastewater Dioxin Discharges from Focus Group 3 Based On Industry Data	6-71
6-42	Comparison of Wastewater Dioxin Discharges from Focus Group 3	6-72
6-43	List of Facilities Manufacturing Chlor Alkali, EDC, VCM, and PVC	6-73
6-44	Vinyl Manufacturing and Chlor-Alkali Facility Dioxins in Wastewater	6-79
6-45	Chlorine Production in the United States	6-80
6-46	Counts of CFPR Facilities	6-87
6-47	Chemical Releases to Surface Water Reported to TRI for 2000	6-89
6-48	Pollutant Discharges Reported to PCS for 2000	6-90
6-49	PCS and TRI TWPEs by SIC Code for CFPR Sectors	6-93
6-50	Wastewater Treatment Practices at CFPR Facilities	6-93
7-1	Facilities Reporting to TRI and PCS Under SIC Code 2911 that are Not Operating Refineries	7-5

LIST OF TABLES (Continued)

		Page
7-2	2000 Discharge Status for Petroleum Refineries	7-10
7-3	Reformer Catalyst Regeneration Processes in 2000	7-14
7-4	Process Wastewater at Petroleum Refineries	7-24
7-5	Discharges Reported to the 2000 TRI for the Petroleum Refining Industry - Pollutants Comprising Approximately 90 Percent of the TWPE	7-26
7-6	Stormwater Discharges Reported to the 2000 TRI	7-27
7-7	Discharges Reported to the 2000 PCS for the Petroleum Refining Industry - Top 10 Pollutants Composing 91 Percent of the TWPE	7-27
7-8	Wastewater Treatment Operations Reported By Petroleum Refineries, TRI Reporting Year 2000	7-29
7-9	Individual Polycyclic Aromatic Compounds	7-30
7-10	Individual PACs and Petroleum Refinery Sources	7-32
7-11	Petroleum Refineries Reporting Releases of PACs to the 2000 TRI	7-34
7-12	California Refineries Reporting PAH Discharges	7-35
7-13	Individual PACs Reported in 2000 PCS	7-35
7-14	PAC Measurement Data from Activated Sludge Units at 10 Refineries	7-36
7-15	NPRA and API Comments on PAC Discharge Estimates Reported to the 2000 TRI	7-38
7-16	Estimated Concentration of PACs in Petroleum Refining Effluent	7-41
7-17	Individual Dioxin Congeners	7-44
7-18	Petroleum Refineries Reporting Releases of Dioxins to 2000 TRI	7-46
7-19	Petroleum Refineries Reporting 2,3,7,8-TCDD to the 2000 PCS	7-47
7-20	Dioxin Sampling Data from Washington State Refineries (2000-2003)	7-48
7-21	TCDD Equivalents in Petroleum Refinery Wastes	7-49

LIST OF TABLES (Continued)

		Page
7-22	NPRA and API Comments on Dioxin Discharge Estimates Reported to the 2000 TRI	7-51
7-23	Dioxin Concentrations Measured in U.S. Petroleum Refinery Final Effluent	7-53
7-24	Treated Effluent Dioxin/Furan Sample Results, pg/L	7-56
7-25	Metals in Petroleum Refining Wastewater	7-63
7-26	Metals Discharges as Percentage of Total TWPE	7-64
7-27	Top Five Metals as Percentage of Total Metal TWPE	7-65
7-28	Five Metals with Highest Estimated TWPE (TRI)	7-65
7-29	Five Metals with Highest Estimated TWPE (PCS)	7-66
7-30	Pollutant Discharge Concentrations for Metals at Petroleum Refineries	7-68
7-31	Conventional and Nonconventional Pollutant Discharges in PCS	7-72
7-32	Conventional Pollutants with Highest Estimated Pounds Discharged (PCS) .	7-73
7-33	Nonconventional Pollutants with Highest Estimated TWPE (PCS)	7-73
7-34	Pollutant Discharge Concentrations for Conventional and Nonconventional Pollutants at Petroleum Refineries	7-74
7-35	Geographic Distribution of PBSTs, per 1997 Economic Census	7-88
7-36	Facilities Reporting to TRI and PCS in 2000 and Their Discharge Status ...	7-89
7-37	Concentrations That Would Render Tank Bottoms Water a RCRA Hazardous Waste	7-101
7-38	Sample Limits in North Carolina’s Stormwater General Permit	7-104
7-39	Parameters Considered by Ohio While Developing Permits	7-106
7-40	Limitations by Discharge Type	7-107
7-41	Arkansas Limits by Outfall Type	7-108

LIST OF TABLES (Continued)

	Page
7-42	Texas General Permit Limits 7-109
7-43	Oregon Stormwater Pollution Control Plan benchmarks 7-110
7-44	TWPE Discharges of Individual Pollutants Based on 2000 TRI Data 7-111
7-45	TWPE Discharges of Individual Pollutants Based on 2000 PCS Data 7-112
7-46	Percent Discharges to Surface Waters Due to Stormwater for 2000 TRI Reporters 7-112
8-1	Decay Coefficients for Nitrogen and Phosphorus, Segregated by Stream Flowrate 8-3
8-2	Nitrogen Compounds Reported to TRI and PCS by OCPSF and Petroleum Refining Facilities 8-4
8-3	Phosphorus Parameters Reported to PCS by OCPSF and Petroleum Refining Facilities 8-5
8-4	Summary of Screening-level Nutrient Analysis for Petroleum Refining Direct Discharge Facilities 8-8
8-5	Summary of Screening-level Nutrient Analysis for OCPSF Direct Discharge Facilities 8-9

LIST OF FIGURES

		Page
6-1	Coal Tar Refining Process Flow Diagram	6-31
6-2	Vapor-Phase Aniline Manufacturing Process	6-39
6-3	Dupont/KBR Liquid-Phase Aniline Process	6-40
6-4	Azo Dye Manufacturing Process	6-42
6-5	Mercury Cell Chlor-Alkali Process	6-53
6-6	Membrane or Diaphragm Cell Chlor-Alkali Process	6-54
6-7	Flow Diagram for EDC/VCM Balanced Process	6-56
6-8	Process Flow Diagram for Suspension PVC Productions	6-59
7-1	Semi-Regenerative Catalytic Reforming Process	7-15
7-2	Cyclic Catalytic Reforming Process	7-16
7-3	Continuous Catalytic Reforming Process	7-16

LIST OF ACRONYMS

BAT	Best Available Technology Economically Achievable
BCT	Best Control Technology for Conventional Pollutants
BMP	Best Management Practice
BOD	Biochemical Oxygen Demand
BPJ	Best Professional Judgment
BPT	Best Practicable Control Technology Currently Available
CAA	Clean Air Act
CDD	Polychlorinated Dibenzo-p-dioxin
CDF	Polychlorinated Dibenzofurans
CERCLA	Comprehensive Environmental Response, Compensation, and Liability Act
CFC	Chlorofluorocarbons
COD	Chemical Oxygen Demand
CWA	Clean Water Act
ELGS	Effluent Limitations Guidelines and Standards
EPA	Environmental Protection Agency
EPCRA	Emergency Planning and Community Right-To-Know Act
FIFRA	Federal Insecticide, Fungicide, and Rodenticide Act
NESHAP	National Emissions Standards for Hazardous Air Pollutants
NPDES	National Pollutant Discharge Elimination System
NSPS	New Source Performance Standards
OCPSF	Organic Chemicals, Plastics, and Synthetic Fibers
PAC	Polycyclic Aromatic Compound
PCS	Permit Compliance System
POTW	Publicly-Owned Treatment Works
PSES	Pretreatment Standards for Existing Sources
PSNS	Pretreatment Standards for New Sources
RCRA	Resource Conservation and Recovery Act
SIC	Standard Industrial Classification
TCDD	Tetrachlorodibenzo(p)dioxin
TCDF	Tetrachlorodibenzofuran
TEF	Toxic Equivalency Factor
TEQ	Toxic Equivalent
TOC	Total Organic Carbon
TRI	Toxic Release Inventory
TSCA	Toxic Substances Control Act
TSDF	Treatment, Storage, and Disposal Facilities
TSS	Total Suspended Solids
TWF	Toxicity Weighting Factor
TWPE	Toxic-Weighted Pound Equivalent
VOC	Volatile Organic Compound

SECTION 1 BACKGROUND

The Effluent Guidelines Program is one part of EPA's Clean Water Act Program. This section explains how the Effluent Guidelines Program fits into the Clean Water Act Program, describes the general and legal background of the Effluent Guidelines Program, and describes EPA's process for making effluent guidelines revision and development decisions.

1.1 EPA's Clean Water Act Program

EPA's Office of Water is responsible for implementing the Clean Water Act (or "CWA"), which provides EPA and the states with a variety of programs and tools to protect and restore the Nation's waters. These programs and tools generally rely either on water-quality-based controls, such as water quality standards and water-quality-based permit limitations, or technology-based controls such as effluent guidelines and technology-based permit limitations. Permits developed using the technology-based industrial regulations have been a critical element of the Nation's clean water program for the past 30 years, helping EPA and the states substantially reduce industrial water pollution.

The CWA gives states the primary responsibility for establishing, reviewing, and revising water quality standards. These consist of designated uses for each water body (e.g., fishing, swimming, supporting aquatic life), numeric pollutant concentration limits ("criteria") to protect those uses, and an antidegradation policy. EPA develops national criteria for many pollutants, which states may adopt or modify as appropriate to reflect local conditions. While technology-based permits may, in fact, result in meeting state water quality standards, the effluent guidelines program is not specifically designed to ensure that the discharge from each facility meets the water quality standards for that particular water body. For this reason, the CWA also requires states to establish water quality-based permit limitations, where necessary to attain and maintain water quality standards, that require industrial facilities to meet requirements that are more stringent than those in a national effluent guideline regulation. Consequently, in the overall context of the CWA, effluent guidelines must be viewed as one tool in the broad arsenal of tools Congress provided to EPA and the states to protect and restore the Nation's water quality.

1.2 The Effluent Guidelines Program

The Effluent Guidelines Program is one component of the Nation's clean water program, established by the 1972 CWA. The national clean water industrial regulatory program is authorized under sections 301, 304, 306 and 307 of the CWA and is founded on six core concepts.

First, the program is designed to address specific industrial categories. To date, EPA has promulgated effluent guidelines that address 56 categories — ranging from manufacturing industries such as petroleum refining to service industries such as centralized waste treatment. These regulations apply to between 35,000 and 45,000 facilities that discharge

directly to the Nation's waters, as well as another 12,000 facilities that discharge into publicly owned treatment works (POTWs).

Second, national effluent guideline regulations typically specify the maximum allowable levels of pollutants that may be discharged by facilities within an industrial category or subcategory. While the limits are based on the performance of specific technologies, they do not generally require the industry to use these technologies, but rather allow the industry to use any effective alternatives to meet the numerical pollutant limits.

Third, each facility within an industrial category or subcategory must generally comply with the applicable discharge limits — regardless of its location within the country or on a particular water body. See CWA section 307(b) and (c); and CWA section 402(a)(1). The regulations, therefore, constitute a single, standard, pollution control obligation for all facilities within an industrial category or subcategory.

Fourth, in establishing national effluent guidelines for pollutants, EPA considers various factors, including: (1) the performance of the best pollution control technologies or pollution prevention practices that are available for an industrial category or subcategory as a whole; and (2) the economic achievability of that technology, which can include consideration of costs, benefits, and affordability of achieving the reduction in pollutant discharge.

Fifth, national regulations apply to three types of facilities within an industrial category: existing facilities that discharge directly to surface waters (i.e., direct dischargers); existing facilities that discharge to POTWs (indirect dischargers); and newly constructed facilities (new sources) that discharge to surface waters either directly or indirectly.

Direct and Indirect Discharges

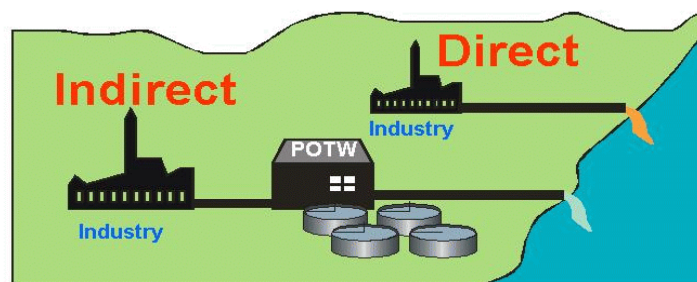

Finally, the CWA section 304(b) requires EPA to conduct an annual review of existing effluent guidelines and, if appropriate, to revise these regulations to reflect changes in the industry and/or changes in available pollution control technologies.

The CWA directs EPA to promulgate effluent limitations guidelines and standards that reflect pollutant reductions that can be achieved by categories or subcategories of industrial point sources using specific technologies. See CWA sections 301(b)(2), 304(b), 306, 307(b), and 307(c). For point sources that discharge pollutants directly into the waters of the United States (direct dischargers), the limitations and standards promulgated by EPA are implemented through National Pollutant Discharge Elimination System (NPDES) permits. See CWA sections 301(a), 301(b), and 402. For sources that discharge to POTWs (indirect dischargers),

EPA promulgates pretreatment standards that apply directly to those sources and are enforced by POTWs and state and federal authorities. See CWA sections 307(b) and (c).

1.2.1 Best Practicable Control Technology Currently Available (BPT) – CWA Sections 301(b)(1)(A) & 304(b)(1)

EPA defines BPT effluent limitations for conventional, toxic, and nonconventional pollutants. Section 304(a)(4) designates the following as conventional pollutants: biochemical oxygen demand (BOD₅), total suspended solids, fecal coliform, pH, and any additional pollutants defined by the Administrator as conventional. The Administrator designated oil and grease as an additional conventional pollutant on July 30, 1979. See 44 FR 44501 (July 30, 1979). EPA has identified 65 pollutants and classes of pollutants as toxic pollutants, of which 126 specific substances have been designated priority toxic pollutants. See Appendix A to part 423, reprinted after 40 CFR Part 423.17. All other pollutants are considered to be nonconventional.

In specifying BPT, EPA looks at a number of factors. EPA first considers the total cost of applying the control technology in relation to the effluent reduction benefits. The Agency also considers the age of the equipment and facilities, the processes employed and any required process changes, engineering aspects of the control technologies, non-water-quality environmental impacts (including energy requirements), and such other factors as the EPA Administrator deems appropriate. See CWA Section 304(b)(1)(B). Traditionally, EPA establishes BPT effluent limitations based on the average of the best performances of facilities within the industry of various ages, sizes, processes or other common characteristics. Where existing performance is uniformly inadequate, BPT may reflect higher levels of control than currently in place in an industrial category if the Agency determines that the technology can be practically applied.

1.2.2 Best Conventional Pollutant Control Technology (BCT) – CWA Sections 301(b)(2)(E) & 304(b)(4)

The 1977 amendments to the CWA required EPA to identify effluent reduction levels for conventional pollutants associated with BCT for discharges from existing industrial point sources. In addition to the other factors specified in Section 304(b)(4)(B), the CWA requires that EPA establish BCT limitations after consideration of a two part “cost-reasonableness” test. EPA explained its methodology for the development of BCT limitations in 1986. See 51 FR 24974 (July 9, 1986).

1.2.3 Best Available Technology Economically Achievable (BAT) – CWA Sections 301(b)(2)(A) & 304(b)(2)

For toxic pollutants and nonconventional pollutants, EPA promulgates effluent guidelines based on the BAT. See CWA Section 301(b)(2)(C), (D) & (F). The factors considered in assessing BAT include the cost of achieving BAT effluent reductions, the age of

equipment and facilities involved, the process employed, potential process changes, non-water-quality environmental impacts, including energy requirements, and other such factors as the EPA Administrator deems appropriate. See CWA Section 304(b)(2)(B). The technology must also be economically achievable. See CWA Section 301(b)(2)(A). The Agency retains considerable discretion in assigning the weight it accords to these factors. BAT limitations may be based on effluent reductions attainable through changes in a facility's processes and operations. Where existing performance is uniformly inadequate, BAT may reflect a higher level of performance than is currently being achieved within a particular subcategory based on technology transferred from a different subcategory or category. BAT may be based upon process changes or internal controls, even when these technologies are not common industry practice.

1.2.4 New Source Performance Standards (NSPS) – CWA Section 306

NSPS reflect effluent reductions that are achievable based on the best available demonstrated control technology. New sources have the opportunity to install the best and most efficient production processes and wastewater treatment technologies. As a result, NSPS should represent the most stringent controls attainable through the application of the best available demonstrated control technology for all pollutants (i.e., conventional, nonconventional, and priority pollutants). In establishing NSPS, EPA is directed to take into consideration the cost of achieving the effluent reduction and any non-water-quality environmental impacts and energy requirements.

1.2.5 Pretreatment Standards for Existing Sources (PSES) – CWA Section 307(b)

PSES are designed to prevent the discharge of pollutants that pass through, interfere with, or are otherwise incompatible with the operation of POTWs, including sludge disposal methods at POTWs. Pretreatment standards for existing sources are technology-based and are analogous to BAT effluent limitations guidelines.

The General Pretreatment Regulations, which set forth the framework for implementing national pretreatment standards, are found at 40 CFR Part 403.

1.2.6 Pretreatment Standards for New Sources (PSNS) – CWA Section 307(c)

Like PSES, PSNS are designed to prevent the discharges of pollutants that pass through, interfere with, or are otherwise incompatible with the operation of POTWs. PSNS are to be issued at the same time as NSPS. New indirect dischargers have the opportunity to incorporate into their plants the best available demonstrated technologies. The Agency considers the same factors in promulgating PSNS as it considers in promulgating NSPS.

1.3 Requirements Applicable to Effluent Guidelines Program Planning Efforts

Section 304(b) of the CWA requires EPA to review effluent guidelines for existing direct dischargers each year and to revise such regulations as appropriate. Section

304(b) also specifies factors that EPA must consider when deciding whether revising an effluent guideline is appropriate. See Section IV.A. of the December 31, 2003 Preliminary Effluent Guidelines Program Plan FRN [FRL-7604-7]. Section 304(m) supplements the core requirement of section 304(b) by requiring EPA to publish a plan every two years announcing its schedule for performing this annual review and for revising any effluent guideline it selects for possible revision as a result of that annual review. Section 304(m) also requires the plan to identify categories of sources discharging nontrivial amounts of toxic or nonconventional pollutants for which EPA has not published effluent limitations guidelines under section 304(b)(2) or NSPS under section 306. See CWA section 304(m)(1)(B); S. Rep. No. 50, 99th Cong., 1st Sess. (1985); WQA87 Leg. Hist. 31. Finally, under section 304(m), EPA must establish a schedule for promulgating effluent guidelines for industrial categories for which it has not already established such guidelines, with final action on such rulemaking required not later than three years after the industrial category is identified in a final Effluent Guidelines Program Plan. See CWA section 304(m)(1)(C). EPA is required to publish its Effluent Guidelines Program Plan for public comment prior to taking final action on the plan. See CWA section 304(m)(2).

In addition, CWA section 301(d) requires EPA to review the effluent limitations required by CWA section 301(b)(2) every five years and to revise them if appropriate pursuant to the procedures specified in that section. Section 301(b)(2), in turn, requires point sources to achieve effluent limitations reflecting the application of BAT (for toxic pollutants and nonconventional pollutants) and BCT (for conventional pollutants), as determined by EPA under sections 304(b)(2) and 304(b)(4), respectively. For nearly three decades, EPA has implemented sections 301 and 304 through the promulgation of effluent limitations guidelines. See *E.I. du Pont de Nemours & Co. v. Train*, 430 U.S. 113 (1977). Consequently, as part of its annual review of effluent limitations guidelines under section 304(b), EPA is also reviewing the effluent limitations they contain, thereby fulfilling its obligations under section 301(d) and 304(b) simultaneously.

SECTION 2 PUBLIC COMMENTS ON THE PRELIMINARY EFFLUENT GUIDELINES PROGRAM PLAN FOR 2004/2005

EPA published its preliminary 2004/2005 Effluent Guidelines Program Plan on December 31, 2003 (68 FR 75515-75531). Comments EPA received on this preliminary plan are located in EPA Docket Number OW-2003-0074. This section provides background information on the list of commenters to and issues raised on the Preliminary Effluent Guidelines Program Plan.

The Agency received 59 comments from a variety of commenters including industry and industry trade associations, municipalities and sewerage agencies, environmental groups, other advocacy groups, two tribal governments, a private citizen, a federal agency, and a state government agency. Stakeholders' suggestions played a significant role in the 2004 annual review. Examples of industrial sectors identified by commenters include OCPSF, petroleum refining, metal finishing, coastal oil and gas extraction, and coalbed methane extraction. Table 2-1 lists all commenters on the Preliminary Plan as well as a synopsis of the comments.

**Table 2-1. Comments on Preliminary Effluent Guidelines Program Plan for 2004/2005
EPA Docket Number: OW-2003-0074**

No.	Commenter Name	EPA E-Docket No. ¹	Comment Synopsis
Environmental Groups			
1	Chesapeake Bay Foundation	0685	Plan should focus on industries discharging excess nutrients, including meats, paper, chemicals, and textiles. There is low-cost technology available for control of Total N and Total P.
2	Natural Resources Defense Council	0733	"(USEPA) to announce a schedule for revising inadequate guidelines and promulgating new guidelines for industries not already subject to technology standards."
3	Cook Inlet Keeper	0735	"Keeper supports revision of the 1982 Effluent Guidelines for petroleum refining, and including petroleum bulk stations and terminals in this revision."
4	Environmental Advocates	0706	"EGP as proposed violates CWA section 304(m)(1)2 and CWA Section 301(d)3 in four key respects."
Municipalities and POTWs			
5	Metropolitan Council Environmental Services, Minnesota	0670	Responds to EPA's request for information on Pretreatment Program. Generally supports guidance rather than regs. Industry information on Airport Deicing (strongly disappointed that EPA did not regulate), Dental Clinics (supports guidance), Groundwater Remediation (standards may be helpful), Drinking Water (adequately covered), Food Service (seem to be adequately covered), Stand-Alone Labs (adequately handled), Industrial Laundries (time to regulate has passed), Printing & Publishing (regs would be burdensome).

Table 2-1 (Continued)

No.	Commenter Name	EPA E-Docket No. ¹	Comment Synopsis
6	Clean Water Services, Oregon	0681	Requests that EPA consider revising Metal Finishing since it unnecessarily classifies iron phosphaters as Metal Finishers; also believes "the regulation needlessly ignores an opportunity to encourage certain pollution prevention practices associated with some chemical conversion coating operations."
7	County Sanitation Districts of Los Angeles County, California	0684	Supports risk analysis and encourages better use of 303d list. Requests replacing production-based limits with concentration-based limits. Provides data for OCPSF (dioxin and PACs not detected; sodium nitrite use), CFPR (types of operations and limits development), Petroleum Refining (PACs, dioxin, vanadium), PBST (water sources). Provides effluent data for several industries, pollutant sources, technologies. Supports strategy, evaluation of risk, provision of permit-based support to states. Provides information on implementation issues.
8	Narragansett Bay Commission, Rhode Island	0692	"The Narragansett Bay Commission (NBC) does not recommend any revision to the two categories outlined in the plan."
9	Hampton Roads Sanitation District, Virginia	0716	"HRSD continues to recommend that EPA focus more of its attention on revising and updating the existing pretreatment standards."
10	Metropolitan St. Louis Sewer District, Missouri	0480	Provides comments/recommendations and information on CFPR and PBST. Includes about 200 pages of attachments.
11	City of Canby, Oregon	0663	Requests that EPA consider revising Metal Finishing that unnecessarily classifies iron phosphaters as Metal Finishers. Excluding them might encourage some dischargers to consider switching from a phosphating process that contains zinc or manganese to one that contains iron, thus promoting a pollution prevention alternative. Suggests that this revision also encourage pollution prevention practices associated with some chemical conversion coating operations.
12	King County Wastewater Treatment Division, Washington	0704	The guidelines program should "be used as an opportunity to introduce monitoring flexibility so as to reduce the monitoring burden placed on POTWs."
13	Metropolitan Sewer District of Greater Cincinnati, Ohio	0741	"The District recommends that the USEPA evaluate the need for an effluent limit guideline for the drum reconditioning and tote recycling industry."
14	City of Troutdale, Oregon	0441	Recommends that the EPA draft an exemption for the iron phosphate process from Metal Finishing. The ability to exempt this industrial waste stream will save the City of Troutdale a considerable amount of resources while not risking water quality.

Table 2-1 (Continued)

No.	Commenter Name	EPA E-Docket No. ¹	Comment Synopsis
15	City of Corvallis, Oregon	0664	Requests that EPA consider revising Metal Finishing that unnecessarily classifies iron phosphaters as Metal Finishers. Excluding them might encourage some dischargers to consider switching from a phosphating process that contains zinc or manganese to one that contains iron, thus promoting a pollution prevention alternative. Suggests that this revision also encourage pollution prevention practices associated with some chemical conversion coating operations.
16	Hazel Dell Sewer District (Clark County Washington)	0668	Requests that EPA consider revising Metal Finishing since it unnecessarily classifies iron phosphaters as Metal Finishers, a process that contributes little or no metals to the waste stream. Suggests excluding them, and asserts that the regulation needlessly ignores an opportunity to encourage certain pollution prevention practices associated with some chemical conversion coating operations.
17	City of Gresham, Oregon	0679	Requests that EPA consider revising Metal Finishing since it unnecessarily classifies iron phosphaters as Metal Finishers; also believes "the regulation needlessly ignores an opportunity to encourage certain pollution prevention practices associated with some chemical conversion coating operations."
18	Gulf Coast Waste Disposal Authority	0680	Provides data showing no detectable PACs in refinery effluent to POTW, and POTW removal efficiency of >99%. EPA deviated from the draft <i>Strategy</i> in assessing industries and did not address risk. Issues with stakeholder comments on OCPSF.
Federal Agencies			
19	Department of Defense	0687	There is no need to create an additional regulation for Petroleum Bulk Stations and Terminals.
Industry and Related Trade Associations			
20	American Chemistry Council	0697	"U.S. EPA's Preliminary Plan has prematurely identified target industries without demonstrating a compelling reason to pursue detailed study of these industries."
21	Chlorine Chemistry Council	0712	"The Organic Chemicals, Plastics, and Synthetic Fibers (OCPSF) industrial category should not be identified for possible effluent guidelines rulemakings."
22	Vinyl Institute, Inc.	0731	"We agree that permit writing support to the States makes more sense in this case than revising an effluent guideline for an entire industry category."
23	Dow Chemical Company	0709	"USEPA's (USEPA) effluent guidelines plan and screening activities should be based on identified water quality impacts."
24	DuPont	0737	"DuPont encourages USEPA as it moves forward to involve the regulated community in any further data gathering efforts for specific industrial categories."

Table 2-1 (Continued)

No.	Commenter Name	EPA E-Docket No. ¹	Comment Synopsis
25	General Electric Company	0740	"General Electric (GE) congratulates the Agency on its regulatory improvement efforts."
26	National Paint and Coatings Association	0683	Agrees that EPA's former studies of adhesives and sealants and CFPR do not warrant ELG development. EPA gathered data during development of the Miscellaneous Coatings Manufacturing (MCM) MACT Standard that shows lack of wastewater generation at adhesives and sealants plants.
27	The Adhesive and Sealant Council, Inc.	0698	"EPA cannot include these industries under the OCPSF category since the processes, wastewater, pollution prevention and treatment options are significantly different."
28	American Forest & Paper Association	0715	"American Forest & Paper Association supports USEPA's (USEPA) decision not to review the effluent guidelines issued for the Phase I mills."
29	Buckeye	0678	Requests that EPA withdraw the 1993 proposed rules for dissolving kraft pulp mills and strongly urges EPA to complete the promulgation of revised Pulp Phase III rules for which Buckeye provided data and support.
30	Rayonier	0690	"The definition of bleach plant should include extraction stages that precede the first application bleaching chemicals."
31	Treated Wood Council (TWC)	0752	"The Treated Wood Council (TWC) does not agree with the listing of Timber Products Processing, including Wood Preserving, as a category in need of additional Investigation."
32	Utility Water Act Group	0726	"UWAG strongly supports USEPA's (USEPA) preliminary decision not to revise the steam electric effluent guidelines in 2004-2005."
33	American Petroleum Institute	0666, 0729, 0750	<p>Asserts that revising Petroleum Refining effluent guidelines would be costly and time-consuming process for both the industry and EPA. Asserts that there is no justification for revising the ELG: no evidence of adverse effects from discharges, and no new cost-effective treatment technologies.</p> <p>"There would be little or no environmental benefit to be gained by reopening this regulation for review."</p> <p>"Development of effluent limitations guidelines and standards for the petroleum bulk storage terminal (PBST) category would waste Agency and industry resources."</p>
34	National Petrochemical & Refiners Association	0747	"USEPA has not demonstrated a need for revising the current guidelines through this notice."
35	ConocoPhillips	0686	"ConocoPhillips recommends that USEPA utilize their four factor analysis to assess and screen industries for guidelines review utilizing monitoring data available from the States."

Table 2-1 (Continued)

No.	Commenter Name	EPA E-Docket No. ¹	Comment Synopsis
36	Amerada Hess	0693	"Amerada Hess does not support the development of effluent guidelines for petroleum bulk stations and terminals."
37	ChevronTexaco	0714	"USEPA's (USEPA) proposal leaves many individual sectors without any effluent guidelines."
38	Petroleum Marketers Association of America	0689	Comment focusing on the questions asked in the <i>Federal Register</i> about discharge of wastewater from bulk plants.
39	Independent Liquid Terminals Association	0702	"USEPA should not add petroleum bulk stations and terminals (PBSTs) as a new subcategory of the Petroleum Refining category."
40	Independent Fuel Terminal Operators Association	0708	"The Independent Fuel Terminal Operators Association strongly recommends that USEPA refrain from initiating a rulemaking for this subcategory of facilities" [Petroleum bulk stations and terminals].
41	New England Fuel Institute	0713	"EPA should not establish Effluent Guidelines for petroleum bulk stations and terminals."
42	Alyeska Pipeline Service Company	0719	"Alyeska does not support USEPA developing effluent limitations guidelines for terminals and bulk plants."
43	FCC Commercial Furniture	0667	Urges EPA to revise Metal Finishing to exclude iron phosphating from subject operations; suggests this exclusion would encourage other sources to switch from zinc, nickel, or manganese phosphating operations to iron phosphating, resulting in environmental benefit. Argues that the Metal Finishing regulation should be consistent with the MP&M ELGs. Discharges to Roseburg Urban Sanitary Authority (see 0408).
44	Operations Management International, Inc.	0408	Requests that the iron phosphate coating process be exempt from Metal Finishing due to a lack of metals in the effluent wastestream.
45	Pharmaceutical Research and Manufacturers of America	0703	Urges "USEPA to revise the proposed plan by rescheduling its evaluation effort to provide the time and resources required to properly implement the draft strategy."
46	Porcelain Enamel Institute	0718	Comment refers to several general flaws in EPA's techniques and data used to evaluate the Porcelain Enamel industry.
47	Edgewater Support Services Inc.	0721	Comment focuses on "an industry sector currently not regulated by effluent guidelines identified during outreach, in particular, airport industrial discharges."
48	National Stone, Sand & Gravel Association	0688	Existing effluent guidelines established by EPA for the aggregates industry under 40 CFR Parts 436.20 and 436.30 are adequate.

Table 2-1 (Continued)

No.	Commenter Name	EPA E-Docket No. ¹	Comment Synopsis
49	Association of American Railroads	0696	"A national effluent limitation guidelines regulation should be initiated only if a significant number of impaired waters would truly benefit."
50	Uniform & Textile Service Association	0720	"UTSA supports USEPA's (USEPA) current methodology that considers industries that are 100% populated with indirect discharges (facilities that discharge directly to the sanitary sewer) as 'trivial'."
51	Barnes & Thornburg	0723	"USEPA's (USEPA) Effluent Guidelines Plan should be based on sound science and collaborative efforts."
Other Advocacy Group			
52	League of Women Voters of Westchester, NY	0691	"Opposition to the proposed guidelines which would lead to the relaxation of current sewage treatment requirements under the Clean Water Act."
53	Prince William Sound Regional Citizens' Advisory Council	0669	Agrees with EPA's focus on OCPSF and Petroleum Refining, including PBST (esp. terminals such as the Valdez Marine Terminal (VMT)). Urges EPA to consider cross-media transfer of pollutants from water to air (e.g., via air stripping) driven by tight water quality regulations. Recommends EPA include both concentration-based AND mass-based limits, since concentration-based limits alone may allow considerable quantities of pollutants to be discharged at low concentrations in very large volumes of effluents such as those at the VMT. Notes that refineries in California have greatly reduced pollutants entering the environment by using better technologies for dissolved air floatation and biological rendering.
54	Virginia Association of Wastewater Treatment Agencies, Inc.	0710	"The regulation overlooks an opportunity to encourage certain pollution prevention practices associated with some chemical conversion coating operations."
55	Association of Metropolitan Sewerage Agencies	0700	"Before USEPA considers updating or revising any specific existing effluent guidelines it must update the 50 POTW Study."
Tribal Governments			
56	Native Village of Port Graham	0738	"Changes since permit issuance in 1999 warrant a new effluent guidelines analysis for coastal oil and gas facilities and a zero discharge decision by USEPA."
57	Native Village of Eklutna (Marc Lamoreaux)	0751	"Information on Cook Inlet historic ice cover, to see if conditions have changed to allow barging of platform discharges for disposal."
Private Citizen			
58	Jett, George M.	0722	"A number of areas that need EAD attention."

Table 2-1 (Continued)

No.	Commenter Name	EPA E-Docket No.¹	Comment Synopsis
State Government			
59	Arkansas DEQ (Gilliam, Allen)	0705	"It's (it is) this state coordinator's view that small to medium sized POTWs nationwide are not aware of the rulemaking process, from plan to promulgation."

¹ Use EPA's E-Docket's web site (<http://epa.gov/edockets>), the Docket Number (OW-2003-0074), and the document number in this column to access these comments.

SECTION 3 ANNUAL REVIEW OF EFFLUENT GUIDELINES PROMULGATED UNDER SECTION 304(b)

CWA Section 304(b) requires EPA to conduct an annual review of promulgated effluent guidelines. This section describes the results of the 2003 and 2004 reviews.

3.1 Results of 2003 Annual Review

As a result of its 2003 annual review, EPA identified two industrial categories for detailed investigation in its 2004 annual review: Organic Chemicals, Plastics, and Synthetic Fibers (OCPSF) (Part 414); and Petroleum Refining (Part 419). These categories are referred to as Group I Industry Categories (see Section 5.2). In its review of the OCPSF effluent guidelines, EPA identified a potential new subcategory for more detailed review: chemical formulating, packaging, and repackaging (including adhesives and sealants) operations. EPA also identified a potential new subcategory of the Petroleum Refining category: petroleum bulk stations and terminals.

In addition, EPA identified potentially high risks or hazards associated with discharges from two other industrial categories: Inorganic Chemicals (Part 415) and Nonferrous Metals Manufacturing (Part 421). These categories are referred to as Group II Industry Categories (see Section 5.3). Finally, EPA identified seven other industrial point source categories with relatively high estimates of potential hazard or risk, referred to as Group III Industry Categories (see Section 5.4). EPA's 2003 annual review, including stakeholder comments received as of December 31, 2003, is discussed in the Preliminary Effluent Guidelines Program Plan (FRN [FRL-7604-7]). EPA used the results of the 2003 annual review to inform its 2004 annual review.

3.2 2004 Annual Review

The first component of EPA's 2004 annual review consisted of a screening-level review of all promulgated effluent guidelines. As a starting point for this review, EPA examined screening-level data from its 2003 annual review. EPA reexamined categories listed in the 2003 screening review where:

- Stakeholder comments identified existing effluent guidelines for revision; or
- Additional information or data were available (e.g., from comments on the Preliminary Plan, or contacts with facilities, industry representatives, etc.) to revise pollutant discharge estimates.

EPA focused its 2004 screening-level review on analyzing any new data provided by stakeholders to identify industrial categories whose pollutant discharges potentially pose the greatest hazards or risks to human health and the environment because of their toxicity. EPA

also considered efficiency and implementation issues raised by stakeholders and commenters on the Preliminary Plan. By using this multi-layered screening approach, the Agency concentrated its resources on those point source categories with the highest estimates of toxic-weighted pollutant discharges (based on best available data), while assigning a lower priority to categories that the Agency believes are not good candidates for effluent guidelines revision at this time.

EPA identified the Group I, II, and III in the 2003 annual review (see the December 31, 2003 Preliminary Effluent Guidelines Program Plan, FRN [FRL-7604-7]).

Based on stakeholder comments, EPA included nine industries (Group IV) in the 2004 annual review (see Section 5.5). Group V industries consist of four industries where EPA has promulgated new or revised effluent guidelines within the past seven years, but were still identified by stakeholders as having discharges of concern (see Section 5.6). EPA evaluated implementation and efficiency considerations and potential risks to human health and the environment based on available discharge data from these Group IV and V industries.

Group VI industries (see Section 5.7) ranked low in terms of toxic discharges and were not identified by stakeholders. EPA did not conduct any additional analysis with respect to these Group VI industries in its 2004 annual review

SECTION 4 DATA SOURCES AND LIMITATIONS

This section describes data sources that EPA used in conducting its 2004 annual review of all industrial categories and sectors. In addition, this section discusses some of the limitations of these data sources. Industrial sector discussions (Sections 5 - 7) contain additional information on data sources that are specific to an industry.

4.1 Industry Identification

During its annual review, EPA conducted a screening-level analysis and further category review using readily available, facility-level data. To use these data to evaluate category and industry pollutant discharges, EPA had to identify the industry to which each facility belonged. This subsection discusses issues related to industry identification.

4.1.1 SIC Codes

The three main sources of information EPA used in the screening-level analysis and further category review were the 1997 U.S. Economic Census, and two EPA databases, TRI and PCS (discussed in detail in Sections 4.2.1 and 4.2.2). In each database and in the economic census, information is organized by SIC code. The SIC system is the statistical classification standard underlying all establishment-based federal economic statistics classified by industry (3). Although it was developed by the Office of Management and Budget, the SIC system is used by other government agencies, including EPA, to promote data comparability. In the SIC system, each establishment is classified according to its primary economic activity, which is determined by its principal product or group of products. An establishment may have activities in more than one SIC code. Some data collection organizations assign one SIC code per establishment (e.g., the economic census). TRI allows reporting facilities to identify their primary SIC code and up to five additional SIC codes. PCS includes one four-digit code, reflecting the principal activity causing the discharge at each facility. For a given facility, the SIC code in PCS may differ from the primary SIC code identified in TRI.

4.1.2 Relationship Between SIC Codes and Point Source Categories

EPA's effluent limitations guidelines and standards (ELGS) are developed for specific categories of industrial dischargers. EPA has developed guidelines and standards for 56 point source categories. The categories, which may be divided into subcategories, are generally defined in terms of combinations of products made and the processes used to make these products. Regulations for an individual point source category may apply to one SIC code, multiple SIC codes, or a portion of the facilities in an SIC code. Thus, to use databases that identify facilities by SIC code, EPA linked each 4-digit SIC code to an appropriate point source category. For facilities discharging significant amounts of toxic pollutants, EPA reviewed readily available information to confirm that the appropriate point source category had been identified for the facility (1,2).

There are some SIC codes for which EPA has not established national ELGS. EPA's evaluation of industrial sectors not regulated by existing guidelines is presented in Section 9 of this document and in the memorandum, *Commenter - Identified Industrial Sectors Not Meeting (304)(m)(1)(B) Criteria*. During its screening-level review, EPA grouped SIC codes into two-digit major industrial groups. For example, SIC code 8221 (colleges and universities) and SIC code 8299 (schools and educational services) were combined as SIC Major Group 82, educational services. See *Evaluation of RSEI Model Runs (1) Attachment C and Supplemental Figures and Tables for the 2004 Effluent Guidelines Program Plan Technical Support Document* for a table presenting the SIC/point source category crosswalk.

4.1.3 Economic Census

EPA used information from the 1997 U.S. Economic Census to estimate the total number of facilities in each industrial category. EPA used 1997 data because they were the most recent available at the time of this review. The economic census, conducted by the U.S. Department of Commerce, is the systematic measurement of almost all national economic activity in the United States. The 1997 Economic Census covered approximately 97 percent of the Gross Domestic Product (GDP). This census asked questions about the number of manufacturing establishments and the kind, quantity, and value of goods manufactured. Although the census provides data on the number of establishments by SIC code, it does not publish lists of facilities. New facilities might have started operation since the census was taken, and facilities that were counted in the census might have been shut down or were no longer operating by 2000. Nonproduction facilities such as sales offices, distribution warehouses, etc., are also counted as establishments in the census.

4.2 Pollutant Loadings Estimates

Section III of the December 31, 2003 Federal Register notice containing the Preliminary Effluent Guidelines Program Plan FRN [FRL-7604-7] describes how EPA estimated pollutant loadings for each industry in its screening-level analyses. The primary data sources for these analyses are EPA's TRI and PCS databases.

4.2.1 Data from TRI

TRI is the common name for Section 313 of the Emergency Planning and Community Right-to-Know Act (EPCRA). Each year, facilities that meet certain thresholds must report their releases and other waste management activities for listed toxic chemicals. That is, facilities must report the quantities of toxic chemicals recycled, collected and combusted for energy recovery, treated for destruction, or disposed of. A separate report must be filed for each chemical that exceeds the reporting threshold. The TRI list of chemicals for reporting year 2000 includes more than 600 chemicals and chemical categories. For this review, EPA used data for reporting year 2000, because they were the most recent available at the time the review began.

A facility must meet the following three criteria to be required to submit a TRI report for that reporting year:

- (1) *SIC Code Determination*: Facilities in SIC codes 20 through 39, seven additional SIC codes outside this range, and federal facilities are potentially subject to TRI reporting. EPA generally relies on facility claims regarding the SIC code identification. The primary SIC code determines TRI reporting.
- (2) *Number of Employees*: Facilities must have 10 or more full-time employees or their equivalent. EPA defines a “full-time equivalent” as a person that works 2,000 hours in the reporting year (there are several exceptions and special circumstances that are well-defined in the TRI reporting instructions).
- (3) *Activity Thresholds*: If the facility is in a covered SIC code and has 10 or more full-time employee equivalents, it must conduct an activity threshold analysis for every chemical and chemical category on the current TRI list. The facility must determine whether it manufactures, processes, OR otherwise uses each chemical at or above the appropriate activity threshold. Reporting thresholds are not based on the amount of release. All TRI thresholds are based on mass, not concentration. Different thresholds apply for persistent bioaccumulative toxic (PBT) chemicals than for nonPBT chemicals.

In TRI, facilities report annual loads released to the environment of each toxic chemical or chemical category that meets reporting requirements. They must report on-site releases to air, receiving streams, disposal to land, underground wells, and several other categories. They must also report the amount of toxic chemicals in wastes transferred to off-site locations, including discharges to POTWs and other off-site locations, such as commercial waste disposal facilities.

For this review, EPA focused on the amount of chemicals facilities reported either discharging directly to a receiving stream or transferring to a POTW. For facilities discharging directly to a stream, EPA took the annual loads directly from the reported TRI data for calendar year 2000. For facilities that transfer toxic chemicals to POTWs, EPA first adjusted the TRI pollutant loads reported to be transferred to POTWs to account for pollutant removal that occurs at the POTW prior to discharge to the receiving stream. The Agency made this adjustment using POTW removal efficiencies from EPA’s Risk Screening Environmental Indicators (RSEI) model (see Section 2.1.1 of the Water Docket for more information on TRI and the RSEI model).

Facilities reporting to TRI are not required to sample and analyze wastestreams to determine the quantities of toxic chemicals released. They may estimate releases based on mass

balance calculations, published emission factors, site-specific emission factors, or other approaches. Facilities are required to indicate, by a reporting code, the basis of their release estimate. TRI's reporting guidance is that, for chemicals reasonably expected to be present but measured below the detection limit, facilities should use one-half the detection limit to estimate the mass released. The guidance is slightly different for dioxins and dioxin-like compounds in that it allows nondetects to be treated as zero.

TRI allows facilities to report releases as specific numbers or as ranges, if appropriate. Specific estimates are encouraged if data are available to ensure the accuracy; however, EPA allows facilities to report releases in the following ranges: 1 to 10 pounds, 11 to 499 pounds, and 500 to 999 pounds. For this review, EPA used the mid-point of each reported range to represent a facility's releases.

EPA weighted the direct and indirect pollutant releases to surface waters using toxic weighting factors (TWFs) developed by Office of Water/Engineering and Analysis Division (EAD), to calculate TWPE for each reported release. See 4.2.3 and 4.2.4 for more discussion of TWFs and calculation of TWPE. EPA compiled data taken from TRI, the adjusted releases from POTWs to surface waters, the calculated TWPE, and the relationship between SIC codes and point source category into a Microsoft Access™ database named *TRIRelases2000*. The Agency made some corrections to this database as it conducted further study on the TRI data.

4.2.1.1 Utility of TRI

The data collected in TRI are particularly useful for the 304(m) review process for the following reasons:

- TRI is national in scope, including data from all 50 states and U.S. territories;
- TRI includes releases to POTWs, not just direct discharges;
- TRI includes discharge data from manufacturing SIC codes and some other industrial categories; and
- TRI includes releases of many toxic chemicals, not just those already identified as problems and limited in facility discharge permits.

4.2.1.2 Limitations of TRI

For purposes of the 304(m) analyses, limitations of the data collected in TRI include the following:

- Small establishments (less than 10 employees) are not required to report, nor are facilities that don't meet the reporting thresholds. Thus, facilities reporting to TRI may be a very small subset of an industry.
- Release reports are, in part, based on estimates, not measurements, and, due to TRI guidance, may overstate releases, especially at facilities with large wastewater flows.
- Certain chemicals (PACs, dioxin and dioxin-like compounds, metal compounds) are reported as a class, not as individual compounds. Because the individual compounds in the class have widely varying toxic effects, the potential toxicity of chemical releases can be inaccurately estimated.
- Facilities are identified by SIC code, not point source category. For some SIC codes, it may be difficult or impossible to identify the point source category that is the source of the toxic wastewater releases.

Despite these limitations, EPA determined that the data summarized in *TRIReleases2000* were usable for an initial screening-level review and prioritization of the toxic-weighted pollutant loadings discharged by industrial categories. EPA checked for and corrected apparent errors in *TRIReleases2000* (see Section 4.0 of reference (1)). However, the *TRIReleases2000* database developed from TRI is only one of the tools EPA used for its screening-level review. In a second level of review, EPA further evaluated TRI data for prioritized categories.

EPA received many comments relating to using information in TRI to estimate pollutant loadings. These commenters noted additional limitations to the information in the TRI database:

- In some instances, TRI information is based on estimates, not actual monitored data.
- TRI encourages facilities to report some compounds as present at one-half the detection level if a facility suspects that the compound has the potential to be present, even if measured data show the compound is below its detection level. As a result, many companies are conservative and adopt this approach. For facilities with large flows, this can result in large estimates of pounds or toxic pounds of pollutant released with no data to support the compound was ever present.
- The list of chemicals covered by TRI is not all inclusive and changes over time.

- Numerous sources of water pollutant discharges are not subject to TRI reporting requirements.
- Many chemicals have high reporting thresholds, in which cases, a facility is not required to report releases of these chemicals to TRI unless they exceed a certain quantity.
- Information in TRI does not represent national estimates because all facilities are not required to report to TRI.

EPA agrees that the issues raised by commenters are valid and identify data gaps that may lead to overestimates or underestimates when using TRI information as a screening tool. It should be noted that all estimates of toxic and nonconventional pollutant discharges (e.g., TRI reported discharges) in this docket are based on reported data and are not scaled to a national estimate.

4.2.2 Data from PCS

PCS is a computerized management information system maintained by EPA's Office of Enforcement and Compliance Assurance (OECA). It was created to track permit, compliance, and enforcement status of facilities regulated by the NPDES program under the CWA.

More than 65,000 industrial facilities and water treatment plants have obtained permits for water discharges of regulated pollutants. To provide an initial framework for setting permit issuance priorities, EPA developed a major/minor classification system for industrial and municipal wastewater discharges. Major discharges almost always have the capability to impact receiving waters if not controlled and, therefore, have received more regulatory attention than minor discharges. There are approximately 6,400 facilities (including sewerage systems) with major discharges for which PCS has extensive records. Permitting authorities classify discharges as major based on an assessment of six characteristics:

- (1) Toxic pollutant potential;
- (2) Discharge flow:stream flow ratio;
- (3) Conventional pollutant loading;
- (4) Public health impact;
- (5) Water-quality factors; and
- (6) Proximity to coastal waters.

Facilities with major discharges must report compliance with NPDES permit limits via monthly Discharge Monitoring Reports (DMRs) submitted to the permitting authority. The permitting authority enters the reported DMR data into PCS, including the type of violation (if any), concentration and quantity values, and the Quarterly Non-Compliance Report (QNCR) indicators. Minor discharges may, or may not, adversely impact receiving water if not controlled.

Therefore, EPA does not require DMRs for facilities with minor discharges. For this reason, the PCS database includes data only for a limited set of minor dischargers when the states choose to include these data.

Parameters in PCS include water quality parameters (such as pH and temperature), specific chemicals, bulk parameters (such as BOD₅ and total suspended solids (TSS)), and flow rates. Although other pollutants may be discharged, PCS contains only data for the parameters identified in the facility's NPDES permit. Facilities typically report monthly average pounds per day discharged, but also report daily maxima and pollutant concentrations.

For this review, EPA used data for reporting year 2000, to correspond to the data obtained from TRI. EPA used its Effluent Data Statistics (EDS) system program to calculate annual pollutant discharges using the monthly reports in PCS. Because units of measure vary widely in PCS, EPA developed the EDS system to estimate mass loadings based on data stored in PCS. The EDS system uses existing PCS reported mass loading values or multiplies reported discharge flows and effluent concentrations to estimate loadings for each outfall (discharge pipe), taking into account the various units of concentration and flow rates. Where concentrations were reported as below detection limit (BDL), EPA assumed the parameter concentration was equal to zero for parameters never detected by the facility in 2000. For parameters sometimes detected and sometimes not, the "BDL" concentration was set equal to half of the detection limit. The EDS system program sums the monthly loads to calculate annual discharges, interpolating (using average reported loads) for months with missing reports.

EPA weighted the calculated annual pollutant discharges using EAD's TWFs to calculate TWPE for each reported discharge, as it did for the reported TRI releases. See Sections 4.2.3 and 4.2.4 for more discussion of TWFs and calculation of TWPE. EPA compiled data taken from PCS, the calculated TWPE, and the relationship between SIC codes and point source category into a Microsoft Access™ database named *PCSLoads2000*. EPA made necessary corrections to the data taken from PCS as it conducted further study.

4.2.2.1 Utility of PCS

The data collected in PCS are particularly useful for the 304(m) review process for the following reasons:

- PCS is national in scope, including data from all 50 states and U.S. territories;
- Discharge reports included in PCS are based on effluent chemical analysis and metered flows;
- PCS includes facilities in all SIC codes; and

- PCS includes data on conventional pollutants for most facilities and for the nutrients nitrogen and phosphorus for many facilities.

4.2.2.2 Limitations of PCS

Limitations of the data collected in PCS include the following:

- PCS includes only discharges of pollutants identified as problems and currently limited in facility discharge permits;
- Some states do not submit all DMR data to PCS, or do not submit the data in a timely fashion;
- PCS does not include discharge monitoring data from minor dischargers;
- PCS does not include data characterizing indirect discharges from industrial facilities to POTWs;
- Many of the pollutant parameters included in PCS are not chemical compounds (e.g., “total Kjeldahl Nitrogen,” “oil and grease”) and cannot have TWFs;
- In some cases, the PCS database identifies the type of wastewater being discharged; however, most reported flow rates do not indicate the type of wastewater and therefore, total flow rates reported to PCS may include stormwater and noncontact cooling water, as well as process wastewater.
- Facilities are identified by SIC code, not point source category. For some SIC codes, it may be difficult or impossible to identify the point source category that is the source of the toxic wastewater releases.

Despite these limitations, EPA determined that the data summarized in *PCSLoads2000* were usable for an initial screening-level review and prioritization of the toxic-weighted pollutant loadings discharged by industrial categories. EPA checked for and corrected apparent errors in *PCSLoads2000* (see Section 3.2 of reference (2)). However, the *PCSLoads2000* database is only one of the tools EPA used for its screening-level review. In a second level of review, EPA further evaluated PCS data for prioritized categories.

As was the case with TRI, commenters noted additional limitations with the PCS database. They include:

- PCS is not representative of all discharges.

- PCS data is entered into the database manually, which leads to data-entry errors.
- Some facilities in PCS do not provide information on applicable SIC codes.
- Facilities only provide SIC code information for the primary operations. Therefore, data may represent other operations as well.
- Some states have not provided data to the PCS system.

EPA agrees that the issues raised by commenters are valid and represent data gaps that may lead to overestimates or underestimates when using PCS information as a screening tool. It should be noted that all estimates of toxic and nonconventional pollutant discharges (e.g., PCS reported discharges) in this docket are based on reported data and are not scaled to a national estimate.

4.2.3 Toxic Weighting Factors

In the 30 years since Congress passed the 1972 Clean Water Act, EPA has promulgated effluent guidelines that address 56 categories, and in the process has developed a variety of tools and methodologies to evaluate effluent discharges. EAD maintains a Toxics Data Base containing aquatic life and human health toxicity data, as well as physical/chemical property data, for more than 1,900 pollutants compiled from over 100 references. The pollutants in this database are identified by a unique Chemical Abstracts Service (CAS) number. TWFs calculated from these data account for differences in toxicity among the pollutants of concern and provide the means to compare mass loadings of different pollutants on the basis of their toxic potential. For example, a mass loading of a pollutant in pounds per year (lb/yr) may be multiplied by a pollutant-specific weighting factor to derive a "toxic-equivalent" loading (lb-equivalent/yr).

TWFs are derived from chronic aquatic life criteria (or toxic effect levels) and human health criteria (or toxic effect levels) established for the consumption of fish. For carcinogenic substances, EPA sets the human health risk level at 10^{-5} (i.e., protective to a level allowing 1 in 100,000 excess lifetime cancer cases over background). In the TWF method for assessing water-based effects, these toxicity levels of pollutants of concern are compared to a benchmark value that represents the toxicity level of a specified pollutant. EPA selected copper, a toxic metal commonly detected and removed from industrial effluent, as the benchmark pollutant. EPA has used copper in previous TWF calculations for the cost-effectiveness analysis of effluent guidelines. Although EPA revised the water quality criterion for copper in 1998 (to 9.0 micrograms per liter [$\mu\text{g/L}$]), the TWF method uses the former criterion (5.6 $\mu\text{g/L}$) to facilitate comparisons with cost-effectiveness values calculated for other regulations. The former criterion for copper (5.6 $\mu\text{g/L}$) was reported in the 1980 Ambient Water Quality Criteria for Copper document (U.S. EPA, 1980).

To calculate TWF values, EPA adds TWFs for aquatic life effects and for human health effects for each pollutant of concern. EPA uses chronic effects on aquatic life and human health effects from ingesting contaminated organisms (HHOO) as the basis for TWFs. The TWF is calculated by dividing aquatic life and human health criteria (or toxic effect levels) for each pollutant, expressed as a concentration in micrograms per liter ($\mu\text{g/L}$), into the former copper criterion of $5.6 \mu\text{g/L}$:

$$\text{TWF} = \frac{5.6}{\text{AQ}} + \frac{5.6}{\text{HHOO}}$$

where:

TWF	=	toxic weighting factor
AQ	=	chronic aquatic life value ($\mu\text{g/L}$)
HHOO	=	human health (ingesting organisms only) value ($\mu\text{g/L}$)

For more details on how EAD determines TWFs, see *Revisions to EAD's Toxic Weighting Factor Methodology Parameters*, OW-2003-0074-0372.

The TRI reportable chemicals list includes 612 chemicals and compound categories; however, reported direct or indirect discharges to surface water in the 2000 TRI database included a total of 329 TRI chemicals and compound categories. EPA has not developed EAD TWFs for 56 of these chemicals, resulting in a calculated toxicity-weighted discharge of zero for these compounds. Large amounts of two chemical compounds without TWFs, coal tar creosote and nitrite-nitrogen, were reported discharged. The lack of TWFs for these chemicals results in an underestimate of the toxicity-weighted releases from some categories.

4.2.4 Calculation of TWPE

EPA weighted the annual pollutant discharges calculated by *TRIRelases2000* and *PCSLoads2000* using EAD's TWFs to calculate TWPE for each reported discharge. EPA summed the estimated TWPE discharged by each facility in a point source category to understand the potential hazard of the discharges from each category. The following subsections discuss the calculation of TWPE.

4.2.4.1 Methodology and Assumptions Used to Calculate TWPE

Because certain chemicals may have more than one name, chemicals in EPA's TWF database are identified by CAS number. The first step in calculating the TWPE was to associate EPA's TWF with the reported pollutant. EPA identified CAS numbers for chemicals reported in PCS by making the following assumptions:

- All forms of the chemical were assigned the same CAS number (e.g., nitrogen-organic, nitrogen-inorganic, and nitrogen-total were all assigned the CAS number for nitrogen); and
- Chemicals that were reported in different ways were assigned only one CAS number (e.g., nitrate (as NO₃) and nitrate (as N) were both assigned the CAS number for nitrate).

EPA estimated TWFs for some parameters reported in PCS. For example, the Agency calculated TWF for the parameter “aldrin plus dieldrin” by averaging the TWF for the two individual compounds. EPA did not assign TWFs to all parameters reported in PCS, primarily because EPA did not identify CAS numbers for chemicals infrequently reported. In addition, there are no CAS numbers for bulk parameters (such as BOD₅) reported in PCS that are not specific chemical compounds.

Most pollutants reported to TRI are individual chemicals identified by a CAS number. However, in addition to individual chemicals, the TRI reportable chemicals list includes 30 compound categories. EPA identified representative chemicals to use to calculate the TWPE of the compound category. For example, EPA used the TWF for a parent metal for the metal compound category (e.g., the TWF for lead was used for lead compounds). See Table B-1 in the report *Evaluation of RSEI Model Runs* (1), for a complete list of TWFs used to represent TRI chemical compound categories.

Two compound categories are particularly important, due to their relatively high TWFs. These categories are polycyclic aromatic compounds (PACs) and dioxin and dioxin-like compounds. For the screening-level analysis, EPA assumed that all mass-reported as PACs was benzo(a)pyrene and used the TWF for benzo(a)pyrene to calculate the TWPE of reported PACs. This assumption was later modified for some categories, as discussed further in 4.2.4.3. For dioxin and dioxin-like compounds, a category comprising 17 dioxin congeners, EPA used the TWF for 1,2,3,6,7,8-hexachlorodibenzofuran to calculate the TWPE of reported dioxins for the screening-level analysis. EPA chose this TWF because it is the median of the TWFs for the 17 dioxin congeners. EPA later modified this assumption for some categories, as discussed in 4.2.4.2. As a result of the assumptions used, PACs and dioxin and dioxin-like compounds, which represent less than 0.005 percent of the TRI-reported pounds discharged to water, accounted for approximately 93 percent of the total estimated TWPE for TRI releases calculated during EPA’s screening-level analysis.

4.2.4.2 Dioxins and Dioxin-Like Compounds

The term ‘dioxins’ refers to polychlorinated dibenzo-p-dioxins (CDDs) and polychlorinated dibenzofurans (CDFs), which constitute a group of PBT chemicals. There are 17 CDDs and CDFs congeners with chlorine substitution of hydrogen atoms at the 2, 3, 7, and 8 positions on the benzene rings, the most toxic of which is 2,3,7,8-tetrachlorodibenzo-p-dioxin (TCDD). Table 4-1 lists these compounds, their chemical name, and common abbreviated name.

The 17 compounds (called congeners) are referred to as ‘dioxin-like,’ because they have similar chemical structure, similar physical-chemical properties, and invoke a common battery of toxic responses (4), though the toxicity of the congeners varies greatly. In this report, EPA uses the term “dioxins” to refer to all 17 of the 2,3,7,8-substituted CDDs and CDFs.

Dioxins are associated with a range of adverse human health effects, including cancer. EPA’s human health-based water quality criterion (water + organism) for the most toxic dioxin isomer, 2,3,7,8-tetrachlorodibenzo-p-dioxin (dioxin), is 0.005 pg/L (5×10^{-9} ug/L) (6).

EPA has recommended that this water quality criterion be used in conjunction with the 1998 World Health Organization (WHO) toxicity equivalency factors to account for the toxic effects of other dioxin-like compounds. The TEF for 2,3,7,8-tetrachlorodibenzofuran (furan) is 0.1; thus the calculated water quality criterion for furan is 0.05 pg/L.

Dioxins have very low water solubility, and most dioxins discharged to surface waters will adhere to sediments and suspended silts. Dioxins are long-lasting substances that can build up in the food chain to levels that are harmful to human and ecosystem health. Because of their persistence and bioaccumulative properties, they do not break down easily in wastewater treatment systems or in the environment and thus present long-term risks to human health, aquatic life, and wildlife.

EPA’s analytical method for dioxins and furans (Method 1613B) establishes the minimum concentration at which these compounds can be reliably quantified. The minimum level (ML) for 2,3,7,8-TCDD and 2,3,7,8-TCDF is 10 pg/L, 2,000 times higher than the water quality criterion for TCDD and 2,000 times higher than the calculated criterion for TCDF. Thus, even if the amount of TCDD or TCDF in a facility’s effluent is below 10 pg/L (e.g., below detection limits), measured at the final effluent, the discharge could still result in pollutant loadings that are far greater than the quantities the water quality criterion deems acceptable to the environment.

Due to their toxicity and ability to bioaccumulate, the various congeners of dioxin have high toxic weighting factors (TWFs). Consequently, even small mass amounts of dioxin discharges translate into high toxic weighted pounds equivalents (TWPEs).

Toxic Equivalency Factors (TEFs) are used to simplify risk assessment and regulatory control of exposures to dioxins and still account for the relative toxicities of the 17 compounds. As defined by Van den Berg, et al., (6), a TEF is a relative potency value that is based on the results of several in vivo and in vitro studies. TEFs are order of magnitude estimates of the toxicity of a compound relative to 2,3,7,8-TCDD. TEFs along with the measured concentration of dioxin congeners are used to calculate toxic equivalent (TEQ) concentrations. Table 4-1 lists the TEFs for the 17 dioxin and dioxin-like compounds.

Table 4-1. Dioxins and Their Toxic Equivalency Factors

CAS Number	Chemical Name	Abbreviated Name	Toxic Equivalency Factor ¹
CDDs			
1746-01-6	2,3,7,8-tetrachlorodibenzo-p-dioxin	2,3,7,8-TCDD	1
40321-76-4	1,2,3,7,8-pentachlorodibenzo-p-dioxin	1,2,3,7,8-PeCDD	1
39227-28-6	1,2,3,4,7,8-hexachlorodibenzo-p-dioxin	1,2,3,4,7,8-HxCDD	0.1
57653-85-7	1,2,3,6,7,8-hexachlorodibenzo-p-dioxin	1,2,3,6,7,8-HxCDD	0.1
19408-74-3	1,2,3,7,8,9-hexachlorodibenzo-p-dioxin	1,2,3,7,8,9-HxCDD	0.1
35822-46-9	1,2,3,4,6,7,8-heptachlorodibenzo-p-dioxin	1,2,3,4,6,7,8-HpCDD	0.01
3268-87-9	1,2,3,4,6,7,8,9-octachlorodibenzo-p-dioxin	1,2,3,4,6,7,8,9-OCDD	0.0001
CDFs			
51207-31-9	2,3,7,8-tetrachlorodibenzofuran	2,3,7,8-TCDF	0.1
57117-41-6	1,2,3,7,8-pentachlorodibenzofuran	1,2,3,7,8-PeCDF	0.05
57117-31-4	2,3,4,7,8-pentachlorodibenzofuran	2,3,4,7,8-PeCDF	0.5
70648-26-9	1,2,3,4,7,8-hexachlorodibenzofuran	1,2,3,4,7,8-HxCDF	0.1
57117-44-9	1,2,3,6,7,8-hexachlorodibenzofuran	1,2,3,6,7,8-HxCDF	0.1
72918-21-9	1,2,3,7,8,9-hexachlorodibenzofuran	1,2,3,7,8,9-HxCDF	0.1
60851-34-5	2,3,4,6,7,8-hexachlorodibenzofuran	2,3,4,6,7,8-HxCDF	0.1
67562-39-4	1,2,3,4,6,7,8-heptachlorodibenzofuran	1,2,3,4,6,7,8-HpCDF	0.01
55673-89-7	1,2,3,4,7,8,9-heptachlorodibenzofuran	1,2,3,4,7,8,9-HpCDF	0.01
39001-02-0	1,2,3,4,6,7,8,9-octachlorodibenzofuran	1,2,3,4,6,7,8,9-OCDF	0.0001

¹From reference (6).

Beginning with reporting year 2000, facilities meeting certain reporting criteria were required to report to TRI the total mass of the 17 dioxin and dioxin-like compounds released to the environment every year. The combined mass of the 17 compounds is referred to as TM-17. This reporting method does not account for the relative toxicities of the 17 compounds. However, reporting facilities are given the opportunity to report a facility-specific congener distribution. Yet even if dioxins are released to more than one medium, the facility can report only one distribution. The single dioxin congener distribution reported by a facility may not accurately reflect the distribution in each medium in which dioxins are released.

EPA has developed TWFs for each of the 17 dioxin congeners, ranging from 421,600,000 for 2,3,7,8-TCDD to 67,367 for OCDF (8). Table 4-2 presents the TWFs used in the screening-level analysis.

Table 4-2. Dioxins and Their Toxic Weighting Factors

CAS Number	Chemical Name	Abbreviated Name	Toxic Weighting Factor ¹
CDDs			
1746-01-6	2,3,7,8-tetrachlorodibenzo-p-dioxin	2,3,7,8-TCDD	421,600,000
40321-76-4	1,2,3,7,8-pentachlorodibenzo-p-dioxin	1,2,3,7,8-PeCDD	215,384,615
39227-28-6	1,2,3,4,7,8-hexachlorodibenzo-p-dioxin	1,2,3,4,7,8-HxCDD	43,076,923
57653-85-7	1,2,3,6,7,8-hexachlorodibenzo-p-dioxin	1,2,3,6,7,8-HxCDD	41,791,045
19408-74-3	1,2,3,7,8,9-hexachlorodibenzo-p-dioxin	1,2,3,7,8,9-HxCDD	43,076,923
35822-46-9	1,2,3,4,6,7,8-heptachlorodibenzo-p-dioxin	1,2,3,4,6,7,8-HpCDD	4,179,104
3268-87-9	1,2,3,4,6,7,8,9-octachlorodibenzo-p-dioxin	1,2,3,4,6,7,8,9-OCDD	423,510
CDFs			
51207-31-9	2,3,7,8-tetrachlorodibenzofuran	2,3,7,8-TCDF	6,696,140
57117-41-6	1,2,3,7,8-pentachlorodibenzofuran	1,2,3,7,8-PeCDF	3,294,118
57117-31-4	2,3,4,7,8-pentachlorodibenzofuran	2,3,4,7,8-PeCDF	32,941,176
70648-26-9	1,2,3,4,7,8-hexachlorodibenzofuran	1,2,3,4,7,8-HxCDF	6,658,740
57117-44-9	1,2,3,6,7,8-hexachlorodibenzofuran	1,2,3,6,7,8-HxCDF	6,666,667
72918-21-9	1,2,3,7,8,9-hexachlorodibenzofuran	1,2,3,7,8,9-HxCDF	6,666,667
60851-34-5	2,3,4,6,7,8-hexachlorodibenzofuran	2,3,4,6,7,8-HxCDF	6,658,740
67562-39-4	1,2,3,4,6,7,8-heptachlorodibenzofuran	1,2,3,4,6,7,8-HpCDF	665,874
55673-89-7	1,2,3,4,7,8,9-heptachlorodibenzofuran	1,2,3,4,7,8,9-HpCDF	666,667
39001-02-0	1,2,3,4,6,7,8,9-octachlorodibenzofuran	1,2,3,4,6,7,8,9-OCDF	67,367

¹From reference (8).

EPA completed the revision of TWFs for dioxin and its congeners as described in a August 2004 memorandum. These revisions and the resulting TWFs are presented in (8). The revised TWFs were used to recalculate the toxicity-weighted dioxin discharges for two categories for which EPA conducted detailed reviews. The recalculated toxic weighted pound equivalents (TWPE) for these two categories, Organic Chemicals, Plastics, and Synthetic Fibers (OCPSF, including chlor-alkali chlorine manufacture) and Petroleum Refining, are also presented in (8).

As noted in 4.2.4.1, because facilities do not report the mass of individual dioxin congeners released to TRI, EPA did not use the congener-specific TWFs to calculate dioxin TWPE during its screening-level analysis of TRI data. Instead, EPA used the TWF for 1,2,3,6,7,8-HxCDF because its TWF (6,666,667) is the median of the TWFs for the 17 dioxin congeners.

Facilities with NPDES permit requirements to monitor for dioxin are typically required to monitor and report 2,3,7,8-TCDD discharges. When the specific congener was identified in PCS, EPA used the TWF for the congener. In some cases, facilities used TEFs and reported their dioxin discharges as TEQs. EPA used the TWF for 2,3,7,8-TCDD to calculate the TWPE of dioxin discharges reported as TEQ (TCDD-equivalent).

EPA used a different approach to calculate TWPE during its further review of prioritized categories where dioxin was released. These categories include OCPSF, Inorganic Chemicals, Petroleum Refining, Timber Products Processing, and Pulp, Paper, and Paperboard, Phase II. In its further review of these categories, EPA calculated dioxin TWPE using the TRI-reported congener distribution to estimate the mass of each congener in the facility's reported releases to surface waters or transfers to POTWs. If a facility did not report a congener distribution, EPA used an industry-average distribution to calculate the mass of each congener released. After estimating the mass of each dioxin congener released by each dioxin-reporting facility, EPA calculated dioxin TWPE by multiplying the estimated mass of each congener by its TWF.

4.2.4.3 Polycyclic Aromatic Compounds (PACs)

PACs, sometimes known as polycyclic aromatic hydrocarbons (PAHs), are a class of organic compounds consisting of two or more fused aromatic rings. Table 4-3 lists the 21 individual compounds in the PAC category for TRI reporting, Chemical Abstract Service (CAS) number, and EAD TWF. EAD has TWFs for only eight of the 21 PACs.

Table 4-3. Definition of Polycyclic Aromatic Compounds

PAC Compound	CAS Number	Toxic Weighting Factor	Priority Pollutant?
Benzo(a)anthracene	56-55-3	180.9752	✓
Benzo(a)phenanthrene (chrysene)	218-01-9	2.1038	✓
Benzo(a)pyrene	50-32-8	4283.5600	✓
Benzo(b)fluoranthene	205-99-2	421.3560	✓
Benzo(j)fluoranthene	205-82-3		
Benzo(k)fluoranthene	207-08-9	42.1356	✓
Benzo(j,k)fluorene (fluoranthene)	206-44-0	0.8030	✓
Benzo(r,s,t)pentaphene	189-55-9		
Dibenz(a,h)acridine	226-36-8		
Dibenz(a,j)acridine	224-42-0		
Dibenzo(a,h)anthracene	53-70-3	1693.0160	✓
Dibenzo(a,e)fluoranthene	5385-75-1		
Dibenzo(a,e)pyrene	192-65-4		

Table 4-3 (Continued)

PAC Compound	CAS Number	Toxic Weighting Factor	Priority Pollutant?
Dibenzo(a,h)pyrene	189-64-0		
Dibenzo(a,l)pyrene	191-30-0		
7H-Dibenzo(e,g)carbazole	194-59-2		
7,12-Dimethylbenz(a)anthracene	57-97-6		
Indeno(1,2,3-cd)pyrene	193-39-5	1.1388	✓
3-Methylcholanthrene	56-49-5		
5-Methylchrysene	3697-24-3		
1-Nitropyrene	5522-43-0		

PACs are classified as PBT pollutants. They are likely present in petroleum products such as crude oil, fuel oil, diesel fuel, gasoline, and paving asphalt (bituminous concrete) and refining by-products such as heavy oils, crude tars, and other residues. PAHs form as the result of incomplete combustion of organic compounds. PACs and closely related compounds are major constituents of creosote, a commonly used wood preservative.

For TRI, facilities must report the combined mass of PACs released; they do not report releases of individual compounds. In the screening-level review of the 2000 TRI database, EPA assumed that benzo(a)pyrene was the only PAC discharged. Thus, EPA used the TWF for benzo(a)pyrene (4,283) to estimate the TWPE of PACs. Because the TWF for benzo(a)pyrene is higher than any other PAC, this represents a worst-case scenario.

EPA used a different approach to calculate TWPE during its further review of the Petroleum Refining and Timber Products Processing Categories. For refineries, EPA developed a refinery-specific TWF for PACs, based on the concentration of individual PACs in petroleum products and the relative amount of each product processed by the refining industry. The calculated petroleum refinery PAC TWF equals 230.43. See *Memorandum: Toxic Weighting Factor for Petroleum Refining Polycyclic Aromatic Compounds*, 12/11/2003, DCN 00646 for further details.

EPA assumed that composition of PACs released by timber product facilities is proportional to the PACs composition of creosote. EPA weighted the TWFs for the individual PACs present in creosote by the percentage of total PACs in creosote represented by each compound to calculate a creosote PAC TWF of 65.78.

4.3 Impaired Waters Analysis

Under section 303(d)(1) of the CWA, states, territories, and authorized tribes must identify water bodies for which technology-based controls required by the Act are not sufficient to implement applicable water quality standards (i.e., are impaired), and prioritize such water bodies for TMDL establishment. To incorporate the Agency's goal of reducing the number of impaired water bodies into effluent guidelines planning, EPA attempted to quantify the number of facilities in an industrial point source category that discharge the same pollutant (or class of pollutants) that is causing the impairment of the receiving water body. The CWA requires states to identify waters not meeting water quality standards to develop Total Maximum Daily Loads (TMDLs) for those waters (section 303(d) of the CWA). A TMDL is designed to restore the health of the polluted water body by specifying the amount of pollutants that may be present in the water and still have the water body meet water-quality standards. More than 20,000 water bodies across America have been identified as impaired. These waters include more than 300,000 river and shoreline miles and five million acres of lakes. EPA estimates that more than 40,000 TMDLs must be established. The CWA established both TMDLs and effluent guidelines as complementary regulatory programs, as both are necessary for restoring the quality of the Nation's waters and for striving towards the national goal of eliminating the discharge of all pollutants.

PCS facilities were matched to water bodies identified by states, under CWA Section 303(d), as impaired waters if at least one PCS pollutant limit matched at least one of the reasons for impairment. For example, if a PCS facility has a discharge limit for mercury and it is located in a water body that is impaired for mercury, then they were matched. The current impairment analyses only identify spatial relationships between point source dischargers and impaired water bodies, and do not suggest the actual correlations/causal relationships between them. EPA will need to conduct more analyses before determining whether there is any actual causal relationship between industrial point sources and impaired waters.

Other limitations to the data presented in impaired waters analysis include:

- **Under-counting of Facilities Because of Missing SICs:** 26 percent of PCS facilities (45,000 of 168,517) are excluded from the impaired waters analysis because they do not have SIC codes in PCS.
- **Under-estimating of Facility Loads:** A potential next step in the impaired waters analysis would be to determine discharge loads for PCS facilities matched to impaired waters. However, both concentration and discharge flow information are necessary to calculate load estimates for PCS facilities. Consequently, EPA has calculated load estimates primarily for majors because most minors do not have flow information in PCS.

- **Under-counting of Facilities Because They Are Not Indexed to Reaches¹:** 77 percent of PCS facilities are excluded from the impaired waters analysis because they have not been indexed to reaches, including 5 percent of majors (340 of 6,833) and 80 percent of minors (129,350 of 161,684). Twenty-three percent (74, 480) of PCS facilities have been indexed to the National Hydrography Dataset (NHD) reaches. There are a total of 22,347 impaired waters of which 19,674 have been indexed to the NHD, which consists of some 3 million reaches.
- Nationally, 9,741 indexed PCS facilities (1,928 majors and 7,813 minors) have been matched to 3,493 impaired waters. EPA used PCS limits to match major facilities to impaired waters. The Agency used Typical Pollutant Concentrations (TPCs) (average pollutant discharge concentrations by SIC) to match minors to impaired waters, because minors have little or no limit information in PCS.
- **Over-counting of Facilities When Matches Are Based on Typical Pollutant Concentration (TPCs):** Facilities might discharge pollutants for which there are no limits in their permits.
- **Under-counting of Facilities When Matches Are Based on PCS Limits:** Facilities might discharge pollutants for which there are no limits in their permits.
- **Limitations in the Locational Data Quality:** 69 percent of the outfalls in the PCS database had location data considered to be of low quality. For many facilities, particularly minors, facility locations are used as a surrogate for the outfall location.
- NHD data are not available for Alaska, Hawaii, Puerto Rico, and the U.S. Virgin Islands.
- States report only 303(d) impairments for assessed water bodies and most water bodies are unassessed.
- SIC codes are not precise, facilities self-identify their SIC codes, and a single facility may have multiple industrial operations at a single site.

¹A reach is a linear or longitudinal section of a stream or river (or other water body) defined by the upstream and downstream locations of lower stream order tributaries flowing into a higher stream.

4.3.1 Data Gaps and Limitations in Estimating Impairment Analysis

EPA's effort to match facility discharges to impaired waters was limited by data gaps in industry monitoring/reporting of discharges and in the ambient monitoring used by states to develop their lists of impaired waters. Further, when EPA did match a facility discharge to an impaired water body, the Agency could not determine whether the discharge is an insignificant or significant contributor to the water quality problem. EPA is exploring ways to expand its impairments analyses in future annual review cycles (see DCN 557, Section 2.1.3).

4.4 Nutrients Analysis

Nutrients entering surface waters can cause many problems for stream health and aquatic life. Excess nutrients can lead to eutrophication resulting in algal blooms, depleted oxygen levels, fish kills, and reduced biodiversity. EPA examined the potential water quality impacts of nutrient discharges from petroleum refining and OCPSF facilities to surface waters. This analysis used EPA's recommended Section 304(a) ecoregional nutrient criteria and decay coefficients in conjunction with a screening-level stream dilution model. For more information regarding this analysis, see Section 8 of this document.

Data limitations and gaps used in this approach include using the 14 nutrient ecoregions instead of the 84 Level III subcoregions. Due to lack of precise geographical data for the facility location outfalls, EPA used the nutrient criteria for the aggregate ecoregions for the analysis. However, nutrient ecoregions are aggregations of Level III subcoregions where the characteristics affecting nutrient levels are expected to be similar.

In performing the in-stream analysis using the screening-level simple dilution model, EPA assumed the following:

- Background concentrations of each pollutant in the receiving stream are equal to zero; therefore, the analysis evaluates only the impacts of discharging facilities.
- EPA used an exposure duration of 365 days to determine the likelihood of actual excursions of human health criteria or toxic effect levels.
- Each facility obtains the intake process water from a source other than the receiving stream.
- The pollutant load to the receiving stream is continuous and represents long-term facility operations. These assumptions may overestimate risks to human health and aquatic life, but may underestimate potential short-term effects.

- EPA used 1Q10 and 7Q10 receiving stream flow rates to estimate aquatic life impacts; harmonic mean flow rates are used to estimate human health impacts. EPA estimated 1Q10 low flows using the results of a regression analysis of 1Q10 and 7Q10 flows from representative U.S. rivers and stream (Versar, 1992). The Agency estimated harmonic mean flows from the mean and 7Q10 flows as recommended in the *Technical Support Document for Water Quality-based Toxics Control* (EPA, 1991). These flows may not be the same as those used by specific states to assess impacts.
- In performing the analysis, EPA did not consider all pollutant fate processes such as volatilization and hydrolysis. This omission may result in estimated in-stream concentrations that are environmentally conservative (higher).

4.5 References

1. Eastern Research Group, Inc. *Evaluation of RSEI Model Runs*. Prepared for U.S. EPA, Engineering and Analysis Division. December 12, 2003. Docket Section 2.1.1, DCN 00618.
2. Eastern Research Group, Inc. *Development of PCSLoads2000*. Prepared for U.S. EPA, Engineering and Analysis Division. December 12, 2003. Docket Section 2.1.2, DCN 00620.
3. Office of Management and Budget. *Standard Industrial Classification Manual*. 1987.
4. U.S. EPA. *EPCRA Section 313 Guidance for Reporting Toxic Chemicals Within the Dioxins and Dioxin-Like Compounds Category*. EPA-745-B-00-021. Washington, D.C. December 2000.
5. U.S. EPA. *Technical Support Document for Water Quality-Based Toxics Control*. EPA-505/2-90-001, PB91-127415. Washington, D.C. 1991.
6. Van den Berg, et al. "Toxic Equivalency Factors (TEFs) for PCBs, PCDDs, PCDFs, for Humans and Wildlife." *Environ. Health Perspect.* 106:775-792. 1998.
7. Versar, Inc. *Upgrade of Flow Statistics Used to Estimate Surface Water Chemical Concentrations for Aquatic and Human Exposure Assessment*. Prepared for the U.S. EPA. 1992.

8. Zipf, Lynn. *Memorandum to 304(m) Docket, Revisions to TWFs for Dioxin and Its Congeners and Recalculated TWPEs for OCPSF and Petroleum Refining*. August 10, 2004.

SECTION 5 EXISTING INDUSTRY REVIEW

Section 3 describes EPA's 2003 and 2004 annual reviews of industries with existing effluent guidelines. This section discusses the review of each industrial category.

5.1 Organization of this Section

As explained in Section 3, EPA prioritized its 2003 and 2004 review of industries with existing effluent guidelines based on the results of a screening-level analysis. Following this screening-level analysis, EPA placed each industrial category into one of six groups. EPA constructed these groups by considering the discharge estimates of toxic and nonconventional pollution (i.e., Factor 1 analyses). EPA also considered the results of the limited Factor 2 and 3 analyses and the extensive Factor 4 analysis. Additionally, EPA had significant questions about information and data gaps for some industrial categories (e.g., why did Timber Products Processing (Part 429) rank second in TRI and 29th in PCS in terms of TWPE discharged). These groupings reflect EPA's assessment of the strength of the data and information used to estimate the discharges of toxic and nonconventional pollution. Consequently, the groups are not strictly based on the *exact* rank order of toxic and nonconventional pollution discharges. Rather, EPA used its best professional judgment to sort industrial categories into the different groups based on all quantitative and qualitative information collected, compiled, and analyzed. These groups are:

- Group I: Industries that ranked high in the screening-level analysis and for which EPA conducted a detailed study;
- Group II: Industries that ranked high in the screening-level analysis for which EPA has data gaps; the Agency may conduct detailed study in subsequent annual reviews;
- Group III: Industries that ranked high in the screening-level analysis for which EPA has significant data gaps or inconsistencies;
- Group IV: Industries that ranked low in the screening-level analysis but were identified by stakeholders in outreach efforts;
- Group V: Industries for which EPA has recently reviewed and promulgated new effluent limitations guidelines and standards (ELGS); and
- Group VI: Industries that ranked low in the screening-level analysis and not identified in stakeholder outreach.

Table 5-1 lists the industries currently subject to effluent guidelines and their groups.

Table 5-1. Industries Covered by National Clean Water Industrial Regulations

Industrial Category	40 CFR Part	Group
Dairy products processing	405	IV
Grain mills manufacturing	406	VI
Fruits and vegetable processing	407	IV
Canned and preserved seafood	408	IV
Sugar processing	409	VI
Textile mills	410	III
Cement manufacturing	411	VI
Concentrated animal feeding operations (feedlots)	412	V
Electroplating	413	V
Organic chemicals, plastics and synthetic fibers	414	I
Inorganic chemicals manufacturing	415	II
Soaps and detergents manufacturing	417	VI
Fertilizer manufacturing	418	III
Petroleum refining	419	I
Iron and steel manufacturing	420	V
Nonferrous metals manufacturing	421	II
Phosphate manufacturing	422	III
Steam electric power generation	423	III
Ferroalloy manufacturing	424	VI
Leather tanning and finishing	425	VI
Glass manufacturing	426	VI
Asbestos manufacturing	427	VI
Rubber manufacturing	428	VI
Timber products processing	429	III
Pulp, paper and paperboard	430	III,V
Meat products	432	V
Metal finishing	433	V
Coal mining	434	IV, V
Oil and gas extraction	435	IV, V
Mineral mining and processing	436	IV
Centralized waste treatment	437	V

Table 5-1 (Continued)

Industrial Category	40 CFR Part	Group
Metal products and machinery	438	V
Pharmaceutical manufacturing	439	V
Ore mining and dressing	440	III
Industrial laundries	441	V
Transportation equipment cleaning	442	V
Paving and roofing materials	443	VI
Waste combustors	444	V
Landfills	445	V
Paint formulating	446	VI
Ink formulating	447	VI
Aquatic animal production	451	V
Gum and wood chemicals	454	VI
Pesticide chemicals	455	VI
Explosives	457	VI
Carbon black manufacturing	458	VI
Photographic	459	VI
Hospitals	460	VI
Battery manufacturing	461	VI
Plastic molding and forming	463	VI
Metal molding and casting	464	IV
Coil coating	465	IV
Porcelain enameling	466	VI
Aluminum forming	467	VI
Copper forming	468	VI
Electrical and electronic components	469	IV
Nonferrous metals forming and metal powders	471	VI

5.2 Group I Industries

The Group I industries include Organic Chemicals, Plastics and Synthetic Fibers (OCPSF) (Part 414), which includes an additional subcategory for Chemical Formulators, Packagers and Repackers (CFPR), and Petroleum Refining (Part 419), which includes an additional subcategory for Petroleum Bulk Stations and Terminals (PBSTs). EPA categorized these industries as Group I due to their relatively high toxic-weighted discharges, possible opportunity for increased pollutant control, and potential additional subcategories. As explained in Section 5.1, these are the two industries for which EPA conducted detailed studies in its 2004 annual review. Because EPA collected and analyzed more extensive data for these two industries, it has devoted a single section to each: the OCPSF review in Section 6 and the Petroleum Refining review in Section 7. These sections include additional information on methodology, data sources, and analyses specific to these industries, discusses the analysis of the data collected, and presents the decisions made based on this information.

5.3 Group II Industries

This section describes the detailed review EPA conducted on the Group II industries. Group II industries are those that had relatively high toxic-weighted pollutant discharges in EPA's screening analysis. However, for these industries, EPA had data gaps, which made confirming these toxic discharges more difficult. During the review, EPA attempted to collect additional information for these industries to better assist its decision-making. The Group II industries include Inorganic Chemicals (Part 415) and Nonferrous Metals Manufacturing (Part 421).

5.3.1 Inorganic Chemicals (Part 415)

EPA selected the inorganic chemicals manufacturing industry for review because it ranked high in terms of toxic and nonconventional pollutant discharges during EPA's initial screening-level analyses. As part of this review, EPA conducted further verification of TRI and PCS data and reviewed data on industry characteristics.

This section describes the inorganic chemicals manufacturing industry in the following subsections:

- Section 5.3.1.1 presents an overview of the inorganic chemicals manufacturing industry including the overall Standard Industrial Classification (SIC) codes that make up this industry. This section also presents the number, location, and discharge status of the facilities covered by this industry.
- Section 5.3.1.2 summarizes the regulatory background applicable to the wastewater discharges from this industry.

- Section 5.3.1.3 discusses the wastewater characteristics of the inorganic chemicals manufacturing industry. One subgroup within this industry, SIC code 2812 - chlor-alkali manufacturing, is a major contributor of dioxin and dioxin-like compound releases to wastewater. In addition, chlor-alkali production commonly occurs at integrated OCPSF facilities. Therefore, the characterization of the chlor-alkali production processes and wastewaters are addressed in Section 6 of this document. Section 5.3.1.3 focuses on the other SIC codes that fall within this industry. This subsection also identifies those pollutants of concern based on current data from PCS and TRI.
- Section 5.3.1.4 discusses the treatment and control of wastewaters generated by the inorganic chemicals manufacturing industry.
- Section 5.3.1.5 presents EPA's conclusions regarding the status of this industry and whether it might warrant additional study.

5.3.1.1 Industry Description

The Inorganic Chemicals Manufacturing Point Source Category includes facilities within the following four SIC codes:

- 2812 - Chlor-Alkali;
- 2813 - Industrial Gases;
- 2816 - Inorganic Pigments; and
- 2819 - Other Inorganic Chemicals.

The chlor-alkali (alkali and chlorine) industry, covered under SIC code 2812, produces chlorine, caustic soda, soda ash, sodium bicarbonate, potassium hydroxide, and potassium carbonate. Chlorine and caustic soda account for the bulk of the production. (2)

Industrial gases, covered under SIC code 2813, are used in a wide variety of applications, from cryogenics to fuel for welding torches. Products for this segment of the industry include common elements such as hydrogen, oxygen, and nitrogen, common compounds such as carbon dioxide, and over 100 specialty gases. Because nitrogen and oxygen, which constitute a large fraction of the industrial gas market, are captured by cooling, compressing, and distilling air, little pollution is associated with their production. (2)

Chrome pigments, produced under SIC code 2816, are used in a variety of applications such as paints, plastics, printing inks, alkali-resistant paints and dyes, and rust-inhibitive primers. Chrome yellows and oranges and molybdate chrome pigments compose the majority of the chrome pigments market. These two products, as well as chrome green, contain substantial amounts of lead. (2) Titanium dioxide is also produced under this SIC code and may

be of interest due to the potential generation of chlorinated dioxins and furans from the chloride and chloride ilmenite production processes. (4)

SIC code 2819 covers a variety of chemicals, including small-volume speciality chemicals, bulk acids, salts, phosphates, sulfur, and hydrogen peroxide. These chemicals are used as inputs to basic industrial products such as metals, pulp and paper, and chemicals. (2)

EPA obtained information on the number of facilities in the inorganic chemicals manufacturing industry from four sources: EPA’s estimate of facilities at the time of the final regulation (1982 and 1984), the 1997 U.S. Economic Census, the 1992 and 2000 TRI databases, and the 2000 PCS database (major and minor direct discharging facilities). Table 5-2 presents the number of facilities in the inorganic chemicals manufacturing industry by SIC code from these sources.

Table 5-2. Number of Facilities in Inorganic Chemicals Manufacturing Industry

SIC Code	Final Regulation (1982 and 1984) (2)	1992 TRI Database	1997 U.S. Economic Census	2000 TRI Database	2000 PCS Database - Majors/Minors
2812 - Chlor-Alkali	77	51	39	37	17/7
2813 - Industrial Gases	223	140	630	68	3/38
2816 - Inorganic Pigments	36	47	74	46	16/12
2819 - Other Chemicals	434	412	667	338	57/82
Total	770	650	1410	489	93/139

EPA’s estimates (from the final regulation and the TRI database) show that the number of facilities in the inorganic chemicals manufacturing industry appears to be decreasing over time with significant reductions in the chlor-alkali and the industrial gases sectors.

Table 5-3 presents the current number and percentage of facilities by type of discharge and SIC code based on 2000 TRI data. These data indicate that a majority of facilities within this industry are zero dischargers.

Table 5-3. Number of Facilities by Discharge Type and SIC Code

	SIC Code				Total
	2812	2813	2816	2819	
Direct Dischargers - Number (% of SIC Code)	11 (30%)	9 (13%)	14 (30%)	60 (18%)	94
Indirect Dischargers - Number (% of SIC Code)	1 (3%)	3 (4%)	13 (28%)	69 (20%)	86
Both Direct and Indirect Dischargers - Number (% of SIC Code)	1 (3%)	0 (0%)	7 (15%)	30 (9%)	38

Table 5-3 (Continued)

	SIC Code				Total
	2812	2813	2816	2819	
Zero Dischargers - Number (% of SIC Code)	24 (64%)	56 (82%)	12 (26%)	179 (53%)	271
Total	37	68	46	338	489

Inorganic chemicals manufacturing facilities are located in every region of the United States. An analysis of facility type by location shows that facilities with SIC codes 2812 and 2816 are located primarily in the eastern third of the U.S. and facilities with SIC code 2813 are located primarily in the south.

5.3.1.2 Regulatory Background

Typically, this industry manufactures inorganic chemicals for captive or merchant use in four or more steps starting from raw material to final product. The wastestreams generated by the process vary based on the raw materials used, process sequence and control, recycle potential, handling, and quality control steps. It was this variability, in part, that led EPA to subcategorize the inorganic chemicals manufacturing industry by the type of inorganic product produced since this approach involved the least ambiguity in applying the standards to a given point source. (1)

EPA initially published effluent limitations guidelines and standards for the Inorganic Chemicals Manufacturing category in 1974 for 22 subcategories (i.e., the Phase I rule). EPA then published, in 1975, a Phase II rule for an additional 27 subcategories. Portions of both the Phase I and Phase II rules were remanded to the Agency in 1976. In 1982, EPA published an amendment to the Phase I rule that contained revised effluent limitations guidelines and standards (ELGS) for 10 subcategories followed by an amendment to the Phase II rule in 1986 with revised requirements for six subcategories. Currently, there are 67 subparts in the ELGS for the inorganic chemicals manufacturing industry. EPA reserved 20 of those subparts for various reasons, including the following: no dischargers, the amount or toxicity of the discharge was considered insignificant or too low to treat, or the production or flow was considered too low.

For 24 of the subparts, EPA set the BPT effluent limitations guidelines to require no discharge of wastewater pollutants. Tables 5-4 and 5-5 list the subparts that are reserved and the subparts that have no discharge at BPT, respectively.

Table 5-4. Reserved Subparts in 40 CFR Part 415

Subpart	Description	Subpart	Description
G	Hydrochloric Acid Production	AT	Manganese Sulfate Production
J	Nitric Acid Production	AV	Strong Nitric Acid Production
O	Sodium Carbonate Production	AZ	Potassium Permanganate Production
R	Sodium Metal Production	BA	Silver Nitrate Production
S	Sodium Silicate Production	BD	Sodium Hydrosulfide Production
Y	Ammonia Hydroxide Production	BE	Sodium Hydrosulfate Production
Z	Barium Carbonate Production	BF	Sodium Silicofluorite Production
AF	Carbon Dioxide Production	BG	Sodium Thiosulfate
AK	Cuprous Oxide Production	BI	Sulfur Dioxide Production
AM	Ferrous Sulfate Production	BJ	Zinc Oxide Production

Table 5-5. Subparts in 40 CFR Part 415 Requiring No Discharge at BPT

Subpart	Description	Subpart	Description
B	Aluminum Sulfate Production	AE	Calcium Hydroxide
C	Calcium Carbide Production	AI	Chromic Acid
E	Calcium Oxide Production	AL	Ferric Chloride
K	Potassium Metal Production	AN	Fluorine
L	Potassium Dichromate Production	AO	Hydrogen
M	Potassium Sulfate Production	AQ	Iodine
N	Sodium Bicarbonate Production	AR	Lead Monoxide
P	Sodium Chloride Production	AS	Lithium Carbonate
X	Ammonium Chloride Production	AX	Potassium Chloride
AA	Borax Production	BC	Sodium Fluoride
AB	Boric Acid Production	BH	Stannic Acid
AC	Bromine Production	BK	Zinc Sulfate

Table 5-6 lists the pollutants regulated in the Inorganic Chemicals Manufacturing category by subpart. Note that some subparts have “no discharge” requirements for direct dischargers and numeric limits for indirect dischargers.

Table 5-6. Regulated Pollutants/Parameters by Subpart in 40 CFR Part 415

Subpart	Description	Regulated Pollutants/Parameters ¹
A	Aluminum Chloride	pH
B	Aluminum Sulfate	Zinc
D	Calcium Chloride	Total Suspended Solids (TSS), pH
F	Chlor-Alkali	Mercury (T), Copper (T), Lead (T), Nickel (T), Total Residual Chlorine, TSS, pH
H	Hydrofluoric Acid	Fluoride, Nickel (T), Zinc (T), TSS, pH
I	Hydrogen Peroxide	Cyanide (Amendable to Chlorine), Total Organic Carbon (TOC), TSS, pH
L	Potassium Dichromate	Chromium (T), Chromium (H)
Q	Sodium Dichromate	Chromium (T), Chromium (H), Nickel (T), TSS, pH
T	Sodium Sulfide	Chromium (T), Zinc (T), COD, TSS, pH
V	Titanium Dioxide	Chromium (T), Nickel (T), Iron (T), TSS, pH
W	Aluminum Fluoride	Fluoride (T), Chromium (T), Nickel (T), TSS, pH
X	Ammonium Chloride	Ammonia (as N), pH
AB	Boric Acid	Arsenic, TSS, pH
AG	Carbon Monoxide and By-Product Hydrogen	COD, TSS, pH
AH	Chrome Pigments	Chromium (T), Lead (T), Zinc (T), TSS, pH
AJ	Copper Salts	Copper (T), Nickel (T), Selenium (T), TSS, pH
AP	Hydrogen Cyanide	Cyanide (T), Cyanide (A), Total Residual Chlorine, TSS, pH
AR	Lead Monoxide	Lead
AU	Nickel Salts	Nickel (T), Copper (T), TSS, pH
AW	Oxygen and Nitrogen	Oil and Grease, pH
AY	Potassium Iodine	Iron, Barium, Sulfide, TSS, pH
BA	Silver Nitrate	Silver, TSS, pH
BB	Sodium Bisulfite	Chromium (T), Zinc (T), COD, TSS, pH
BC	Sodium Fluoride	Fluoride
BL	Cadmium Pigments & Salts	Cadmium (T), Selenium (T), Zinc (T), TSS, pH

¹(T) - Total, (H) - Hexavalent.

5.3.1.3 Wastewater Characterization

The wastewater streams generated by the inorganic chemical manufacturing industry vary by subcategory. Examples of the types of wastewater streams generated include noncontact and contact cooling waters, scrubber wastewaters, distillation bottoms, condensates, floor and equipment washings, filter operation wastewaters, and spills and maintenance-related

wastewaters. The Final Inorganic Chemicals TDD (1) provides subcategory-specific information on the production processes and wastes generated by this industry.

For the inorganic chemical manufacturing facilities reporting to the 2000 TRI, EPA estimates a total toxic weighting pound equivalent (TWPE) discharge for the industry of 624,250. The majority of this toxic discharge occurs from 12 facilities. Table 5-7 lists the pollutants reported to TRI as discharged directly or indirectly, which account for 95 percent of the total TWPE. This table presents the number of facilities that reported each chemical, total pounds of chemical discharged, and total TWPE for each chemical. The 2000 TRI database does not include all inorganic chemical manufacturing facilities or TRI-listed chemicals that are used or produced at levels below reporting thresholds.

Table 5-7. 2000 TRI Top Pollutants Discharged by the Inorganic Chemicals Manufacturing Industry

Pollutant	Number of Facilities Reporting	TRI Releases 2000 Total (lb/yr)	TRI Releases 2000 TWPE/yr	Percentage of Total SIC Code TWPE	Cumulative Percentage of Total SIC Code TWPE
Dioxin and Dioxin-like Compounds	11	0.11	266,330	41.1	41.1
Hexachlorobenzene	3	203	147,007	23.5	64.6
Sodium Nitrite	7	243,083	90,751	14.5	79.1
Chlorine	15	99,727	48,565	7.8	86.9
Manganese Compounds	29	224,533	15,815	2.5	89.4
Vanadium Compounds	8	22,766	14,166	2.3	91.7
Chromium Compounds	33	19,759	10,114	1.6	93.3
Silver Compounds	4	588	9,692	1.6	94.9

Source: EPA, *TRIRelases2000*.

Based on the *TRIRelases2000* (see Section 4.2.1), dioxin and dioxin-like compounds represent the largest TWPE discharges for the industry. During its screening-level analysis, EPA identified the Oxy Vinyl L.P. facility located in Deer Park, Texas as discharging the largest dioxin and dioxin-like compound TWPE load. In a subsequent phone contact with the company, EPA learned that the Deer Park, Texas facility closed and therefore, EPA did not include the loads from that facility in the TRI totals in Table 5-7.

For the inorganic chemical manufacturing facilities reporting to PCS for 2000, EPA estimates a TWPE discharge for the industry of 853,568. The majority of this toxic discharge occurs from eight facilities, and half of the TWPE load is due to the discharge of mercury. Table 5-8 lists the pollutants reported to PCS as discharged by major dischargers, which account for 95 percent of the total TWPE. This table presents the number of facilities that reported each chemical, total pounds of chemical discharged, and total TWPE for each chemical.

Table 5-8. 2000 PCS Top Pollutants Discharged by the Inorganic Chemicals Manufacturing Industry

Pollutant	Number of Facilities Reporting	PCS Loads 2000 Total (lbs/yr)	PCS Loads 2000 TWPE/yr	Percentage of Total SIC Code TWPE	Cumulative Percentage of Total SIC Code TWPE
Mercury, Total (as Hg)	24	3,671	429,818	50	50
Chlorine, Total Residual	44	221,979	108,100	13	63
Sulfide, Total (as S)	5	25,634	71,789	8	71
Iron, Dissolved (as Fe)	3	12,673,109	70,969	8	80
Benzo(a)pyrene	12	12	50,109	6	86
Lead, Total (as Pb)	39	18,517	41,479	5	90
Aluminum, Total Recoverable	1	483,625	31,188	4	94
Chloride (as Cl)	15	393,760,079	9,587	1	95

Source: EPA, *PCSLoads2000*.

As described in Section 6, EPA found that the largest dioxin discharges occur at large integrated OCPSF facilities which also operate chlor-alkali plants (whose wastewaters may be subject to the Inorganic Chemicals effluent guidelines (Part 415)). Dioxin discharges are also significant at stand-alone chlor-alkali plants. Because of the connection between dioxin discharges from the chlor-alkali industry and other chloride-related processes at OCPSF facilities, EPA discusses the chlor-alkali production process, wastewaters, and their characterization in Section 6 and is focusing the remainder of this section on SIC codes 2813, 2816, and 2819.

Over the years, the inorganic chemicals manufacturing industry has generated less wastewater as old processes are replaced with new processes that use less water (2). *PCSLoads2000* (see Section 4.2.2) provides total wastewater flow data by SIC code for the inorganic chemicals manufacturing industry; no flow data are provided in *TRIRelases2000*. EPA also evaluated flow using data from the 1992 PCS database included the Preliminary Data Summary for the Inorganic Chemicals Manufacturing category prepared in 1994 (2). Table 5-9 compares the average and total annual wastewater flows for 1992 and 2000 from the PCS database for major dischargers in the industry.

Table 5-9. 1992 and 2000 Wastewater Flows by SIC Code

SIC Code	Number of Major Facilities (1992/2000)	Average Flow 1992 (MGY)	Average Flow 2000 (MGY)	Total Flow 1992 (MGY)	Total Flow 2000 (MGY)
2813 - Industrial Gases	33/3	2,871	13,178	94,731	39,533
2816 - Inorganic Pigments	20/16	3,461	2,831	69,220	45,300
2819 - Other Chemicals	124/57	4,395	2,135	544,927	121,680

Source: EPA, *PCSLoads2000* and 1992 PCS database.

EPA estimated the average flow for 1992 and 2000 by dividing the total flow from PCS by the number of PCS facilities with flow data in each SIC code. As shown in Table 5-9, facilities in SIC code 2819, Other Chemicals, discharge most of the wastewater in this industry. Facilities in SIC code 2816, the inorganic pigments group, discharge the least amount of wastewater.

EPA does not currently have information on the raw waste loads generated by dischargers in the inorganic chemicals manufacturing industry. Therefore, only discharge loads are discussed in the remainder of this section.

Table 5-10 lists the pollutants with the highest percentage of the total TWPE by SIC code based on *TRIRelases2000* for both direct and indirect dischargers. Looking at only SIC codes 2813, 2816, and 2819, the total TWPE discharges based on 2000 TRI data are 479,282.

Table 5-10. Pollutants of Concern from 2000 TRI Data (Direct and Indirect Dischargers)

SIC Code	Pollutant	Regulated Pollutant?	TWPE/yr	Number of Facilities Reporting Discharge	Percentage of TWPE (SIC Code)	Percentage of TWPE (Total)
2813	Chlorine	Yes	937	2	51	0.15
	Selenium	Yes	840	1	46	0.13
2816	Hexachlorobenzene	No	145,559	2	47	23
	Dioxin and Dioxin-like Compounds	No	123,470	6	40	19
2819	Sodium Nitrite	No	85,162	5	51	13
	Chlorine	Yes	45,710	9	27	7
	Vanadium Compounds	No	12,378	5	7	2
	Silver Compounds	Yes	9,692	4	6	1.5

Source: EPA, *TRIRelases2000*.

Table 5-11 lists the same information based on *PCSLoads2000* for direct dischargers. Again, looking at only SIC codes 2813, 2816, and 2819, the total TWPE discharges based on the 2000 PCS data are 683,500.

Table 5-11. Pollutants of Concern from 2000 PCS Data (Direct Dischargers)

SIC Code	Pollutant	Regulated Pollutant?	TWPE/yr	Number of Facilities Reporting Discharge	Percentage of TWPE (SIC Code)	Percentage of TWPE (Total)
2813	Total Mercury	Yes	1,480	1	79	0.17
	Cadmium	Yes	188	1	10	0.02
2816	Iron, Dissolved	Yes	70,969	2	92	8
2819	Total Mercury	Yes	359,939	6	60	42
	Total Residual Chlorine	Yes	84,965	11	14	10
	Benzo(a)pyrene	No	46,254	1	8	5
	Total Lead	Yes	40737	13	7	5

Source: EPA, *PCSLoads2000*.

5.3.1.4 Treatment Technologies

EPA used various technologies as the basis for the Inorganic Chemicals Manufacturing category effluent limitations guidelines and standards, including:

- Aeration;
- Precipitation;
- Clarification;
- Filtration;
- Neutralization;
- Polishing;
- Recycling; and
- Thickening (1).

For 24 of the 67 subcategories, EPA set zero discharge as the basis for the BPT effluent limitations guidelines.

Table 5-12 presents the treatment technologies most commonly used in the inorganic chemicals industry reporting to TRI for 2000.

Table 5-12. Wastewater Treatment Operations Reported By Inorganic Chemicals Manufacturing Facilities, TRI Reporting Year 2000

Wastewater Treatment Process	Number of Facilities Reporting Use	
	Direct (75 Facilities)	Indirect (64 Facilities)
Neutralization	40	43
Chemical Precipitation	44	34
Settling/Clarification	48	30
Filtration	28	27
Equalization	28	12
Sludge Dewatering (Nonthermal)	9	13
Stripping - Air, Steam, or Other	15	6
Biological Treatment	17	1
Adsorption	12	4
Other Chemical Treatment	8	4
General Oxidation (including disinfection)	7	4

Source: Section 7A Table of the TRI 2000 Database.

Most of the direct and indirect discharging facilities reporting to TRI use neutralization, chemical precipitation, settling/clarification, filtration and/or equalization. These types of treatment technologies are consistent with the types used as the technology basis for the inorganic chemicals manufacturing effluent limitations guidelines and standards.

EPA's current evaluation of pollution prevention opportunities for this industry shows that, during the manufacture of inorganic chemicals, there are several opportunities to reduce the amount of pollutants generated and the volume of wastewater that has to be treated. These pollution prevention alternatives include, but are not limited, to:

- Installing mechanical scrapers on filters to eliminate the need to backwash the filters. An example is during the manufacture of sulfate and nickel sulfate.
- Using high purity ore in the manufacturing process, which reduces the amount of impurities in the ore that are discharged to the wastewater. An example is in the manufacture of titanium dioxide.
- Using metal anodes instead of graphic anodes in the manufacturing process, which reduces the amount of lead and organic pollutants discharged to the wastewater. An example is during the manufacture of chlorine using the diaphragm cell process.

- Using noncontact cooling water instead of contact cooling water in the manufacturing process, which reduces the volume of water used as well as the volume of wastewater generated. As an example, this can be done in the diaphragm cell process during the manufacture of chlorine.
- Recovering and reusing inorganic chemicals used in the manufacturing process. For example, chlorine used in manufacturing ferric chloride can be recovered and reused.
- Recycling drip acid used in the manufacturing process. As an example, this can be done during the manufacture of hydrofluoric acid.
- Using an ion exchange process or reverse osmosis to treat wastewater generated during the manufacturing process. Because of the high quality of the treated wastewater, it can be reused for various purposes, which reduces the volume of wastewater discharged. (3)

5.3.1.5 Conclusions

The inorganic chemicals manufacturing industry ranked high in terms of toxic and nonconventional pollutant discharges among all industrial point source categories investigated in EPA's screening-level analyses. Based on *TRIRelases2000*, much of this loading is attributed to dioxin and dioxin-like compounds generated by the chlor-alkali (SIC code 2812) and inorganic pigment (SIC code 2816) industries. EPA notes that, as explained in Section 6, it has identified the chlor-alkali sector of the inorganic chemicals manufacturing ELGS for possible revision. In addition, only a dozen facilities discharge most of the TWPE load for this industry based on 2000 TRI data. Other pollutants of concern for this industry based on 2000 TRI data include hexachlorobenzene, sodium nitrite, chlorine, vanadium compounds, silver compounds, and selenium. Data from the *PCSLoads2000* identify mercury, chlorine, iron, benzo(a)pyrene, lead, and cadmium as pollutants of concern.

EPA does not currently have data on the raw waste loads generated by dischargers in this industry category. Therefore, the Agency would need to collect additional data to assess the pollutant removals occurring in this industry. Additionally, stakeholders in EPA's screening analyses commented that there have been substantial changes to this industrial category since the effluent guidelines were promulgated in 1982. EPA believes that additional study of this industry is warranted to determine whether the existing "no discharge" requirements are reasonable and to assess whether additional BMPs or improved treatment could achieve additional reductions in the pollutants with the highest toxic pounds.

5.3.1.6 References

1. U.S. EPA. *Development Document for Effluent Limitations Guidelines and Standards for the Inorganic Chemicals Manufacturing Point Source Category*. EPA-440/1-82/007. Washington, D.C. June 1982.
2. U.S. EPA. *Preliminary Data Summary for the Inorganic Chemicals Manufacturing Point Source Category*. EPA-821/R-96-016. Washington, D.C. December 1994.
3. Center for Technology and Environmental Management. *Fact Sheet: Best Management Practices for Inorganic Chemicals Manufacturing Industry*. November 25, 1998.
4. U.S. EPA. *Final Titanium Dioxide Listing Background Document for the Inorganic Chemical Listing Determination*. Washington, D.C. October 2001.

5.3.2 Nonferrous Metals Manufacturing (Part 421)

EPA selected the Nonferrous Metals (NFM) Manufacturing Point Source Category for review because it ranked high in terms of toxic and nonconventional pollutant discharges during EPA's screening-level analyses. As part of this review, EPA conducted further verification of Toxic Release Inventory (TRI) and Permit Compliance System (PCS) data and reviewed data on industry characteristics.

This section describes the NFM manufacturing industry in the following subsections:

- Section 5.3.2.1 presents an overview of the NFM manufacturing industry including the overall SIC codes that make up this industry and how those relate to the regulatory subcategories included within the industry. This section also presents the number, location, and discharge status of the facilities in this industry.
- Section 5.3.2.2 summarizes the regulatory background applicable to wastewater discharges from this industry.
- Section 5.3.2.3 discusses the types of wastewaters generated by the NFM manufacturing industry and presents information on how they are characterized. This section also identifies those pollutants of concern based on current data from PCS and TRI.
- Section 5.3.2.4 discusses the treatment and control of wastewaters generated by the NFM manufacturing industry.

- Section 5.3.2.5 presents EPA’s conclusions regarding the status of this industry and whether it might warrant additional study.

5.3.2.1 Industry Description

The NFM Manufacturing category includes sites that smelt and refine metals other than steel, such as aluminum, copper, nickel, and many others. It does not cover mining or forming operations and includes 31 subcategories. Although sites with different primary SIC codes could perform operations covered by Part 421, the main SIC codes that are covered by Part 421 include 3331 (Primary Smelting and Refining of Copper), 3334 (Primary Production of Aluminum), 3339 (Primary Smelting and Refining of Nonferrous Metals, Except Copper), 3341 (Secondary Smelting and Refining of Nonferrous Metals), and a portion of 2819 (Inorganic Chemicals, not elsewhere classified (NEC)).

SIC code 2819 includes several operations covered by Part 421. In EPA’s screening-level analysis, all of the facilities within SIC code 2819 were included as part of the NFM manufacturing and inorganic chemicals manufacturing industries. Further review identified that the following six sites are known to perform NFM manufacturing operations, including the production of refined bauxite, alumina, slug uranium (radioactive), liquid metals, and several inorganic metals. The six sites reporting under SIC code 2819 that are included in EPA’s review for NFM manufacturing are:

1. ALCOA World Alumina in Texas (TRI);
2. ALCOA World Alumina in Florida (TRI);
3. ALCOA World Chemicals in Arkansas (TRI);
4. U.S. Enrichment Corp in Kentucky (TRI and PCS);
5. U.S. Enrichment Corp in Ohio (PCS); and
6. Reynolds Metals Co in Arkansas (PCS).

Table 5-13 below presents the 31 subcategories of the NFM manufacturing industry and the SIC codes covered by Part 421 under which they fall.

Table 5-13. SIC Codes and Subcategories in Part 421

Subcategory		SIC Code	SIC Code Name
1	Bauxite Refining	3334	Primary Smelting and Refining of Copper
2	Metallurgical Acid Plants ¹	3331	Primary Smelting and Refining of Copper
3	Primary Aluminum	3334	Primary Production of Aluminum
4	Primary and Secondary Germanium and Gallium ²	3339	Primary Smelting and Refining of Nonferrous Metals, Except Copper
5	Primary and Secondary Titanium ²	3339	Primary Smelting and Refining of Nonferrous Metals, Except Copper
6	Primary Antimony	3339	Primary Smelting and Refining of Nonferrous Metals, Except Copper

Table 5-13 (Continued)

Subcategory		SIC Code	SIC Code Name
7	Primary Beryllium	3339	Primary Smelting and Refining of Nonferrous Metals, Except Copper
8	Primary Columbium and Tantalum	3339	Primary Smelting and Refining of Nonferrous Metals, Except Copper
9	Primary Copper Smelting	3331	Primary Smelting and Refining of Copper
10	Primary Electrolytic Copper Refining	3331	Primary Smelting and Refining of Copper
11	Primary Lead	3339	Primary Smelting and Refining of Nonferrous Metals, Except Copper
12	Primary Molybdenum and Rhenium	3339	Primary Smelting and Refining of Nonferrous Metals, Except Copper
13	Primary Nickel and Cobalt	3339	Primary Smelting and Refining of Nonferrous Metals, Except Copper
14	Primary Precious Metals and Mercury	3339	Primary Smelting and Refining of Nonferrous Metals, Except Copper
15	Primary Rare Earth Metals	3339	Primary Smelting and Refining of Nonferrous Metals, Except Copper
16	Primary Tungsten	3339	Primary Smelting and Refining of Nonferrous Metals, Except Copper
17	Primary Zinc	3339	Primary Smelting and Refining of Nonferrous Metals, Except Copper
18	Primary Zirconium and Hafnium	3339	Primary Smelting and Refining of Nonferrous Metals, Except Copper
19	Secondary Aluminum	3341	Secondary Smelting and Refining of Nonferrous Metals
20	Secondary Copper	3341	Secondary Smelting and Refining of Nonferrous Metals
21	Secondary Indium	3341	Secondary Smelting and Refining of Nonferrous Metals
22	Secondary Lead	3341	Secondary Smelting and Refining of Nonferrous Metals
23	Secondary Mercury	3341	Secondary Smelting and Refining of Nonferrous Metals
24	Secondary Molybdenum and Vanadium	3341	Secondary Smelting and Refining of Nonferrous Metals
25	Secondary Nickel	3341	Secondary Smelting and Refining of Nonferrous Metals
26	Secondary Precious Metals	3341	Secondary Smelting and Refining of Nonferrous Metals
27	Secondary Silver	3341	Secondary Smelting and Refining of Nonferrous Metals

Table 5-13 (Continued)

Subcategory		SIC Code	SIC Code Name
28	Secondary Tantalum	3341	Secondary Smelting and Refining of Nonferrous Metals
29	Secondary Tin	3341	Secondary Smelting and Refining of Nonferrous Metals
30	Secondary Tungsten and Cobalt	3341	Secondary Smelting and Refining of Nonferrous Metals
31	Secondary Uranium	2819	Smelting or Refining of Uranium (NFM Portion of Inorganic Chemicals SIC Code)

¹EPA assigned the Metallurgical Acid Plants Subcategory to SIC code 3331. According to a conversation with Dan Edelstein of the USGS Minerals Division, metallurgical acid recovery is mostly done from primary smelting. Also, according to the Final NFM Manufacturing Point Source Category Development Document (3), it is more often associated with copper, zinc, lead, and molybdenum.

²EPA assigned this subcategory to SIC code 3339, because EPA was unable to separate the secondary facility loads from the primary facility loads.

The 1997 Economic Census provides information on the number of facilities classified within SIC codes 2819, 3331, 3334, 3339, and 3341. Table 5-14 presents the 1997 Economic Census data, the number of “major” and “minor” direct dischargers submitting data to PCS, and the number of facilities submitting reports to EPA’s TRI for 2000 for this industrial category.

Table 5-14. Number of Operating Facilities, By Year and Data Source

SIC Code		1997 Economic Census	PCS Loads 2000	TRI Releases 2000
2819	Inorganic Chemicals, NEC	6	3/0	4
3331	Primary Smelting and Refining of Copper	16	3/1	5
3334	Primary Production of Aluminum	21	23/3	25
3339	Primary Smelting and Refining of Nonferrous Metals, Except Copper	142	13/5	30
3341	Secondary Smelting and Refining of Nonferrous Metals	256	14/17	172
TOTAL		438	56/26	236

EPA used *TRIRelases2000* to determine the distribution of discharge status. Of the 236 facilities that reported to TRI in 2000, 115 reported releases directly to surface waters and/or transfers to POTWs and the remainder reported zero discharges. Table 5-15 shows the distribution of direct, indirect, both direct and indirect, and zero dischargers reporting to TRI by SIC code.

Table 5-15. Wastewater Discharge Status Reported in TRIRelases2000

SIC Code	Number of Direct Dischargers	Percentage of SIC Code	Number of Indirect Dischargers	Percentage of SIC Code	Number of Both D/I Dischargers	Percentage of SIC Code	Number of Zero Dischargers	Percentage of SIC Code
2819	4	100%	0	0%	0	0%	0	0%
3331	1	20%	2	40%	0	0%	2	40%
3334	14	56%	0	0%	2	8%	9	36%
3339	10	33%	4	13%	4	13%	12	40%
3341	38	22%	23	13%	13	8%	98	57%
Total	67 Total Directs Only		29 Total Indirects Only		19 Total Both Direct and Indirect		121 Total Zero Dischargers	

Source: EPA, TRIRelases2000.

NFM manufacturing facilities are located throughout the United States, with concentrations near raw material sources, transportation centers, markets, or sources of inexpensive energy (1). For copper, lead, zinc, molybdenum, and titanium primary producers, the larger facilities are located near ore mines in the Midwest and West. Secondary metal producers tend to be located near metropolitan areas.

5.3.2.2 Regulatory Background

As described in the 1989 NFM Final TDD (1), EPA promulgated the ELGS for the NFM Manufacturing category in two separate rulemakings, referred to as Phase I and Phase II. In 1984, EPA addressed 12 subcategories that generate the largest quantities of toxic pollutants (Phase I), followed by regulation of 25 additional subcategories in 1985 (Phase II). Because of a series of lawsuits and settlements, EPA repropose the rule several times, with final promulgation of both phases in August 1990. EPA determined that five of the subcategories considered by the Phase I and II rules did not warrant national regulation because no plants in the subcategories discharged wastewater or no plants discharged treatable concentrations of pollutants. These five subcategories were:

- Primary Boron;
- Primary Cesium and Rubidium;
- Primary Lithium;
- Primary Magnesium; and
- Secondary Zinc.

Conventional pollutants controlled in the ELGS, for one or more of the 31 regulated subcategories, include oil and grease (O&G), TSS, and pH. Priority and nonconventional pollutants regulated for one or more of the subcategories include the following:

- | | |
|---------------------|--------------|
| • Aluminum | • Lead |
| • Ammonia (as N) | • Mercury |
| • Antimony | • Molybdenum |
| • Arsenic | • Nickel |
| • Benzo(a)pyrene | • Palladium |
| • Beryllium | • Phenolics |
| • Cadmium | • Platinum |
| • Chromium (total) | • Selenium |
| • Cobalt | • Silver |
| • Copper | • Tantalum |
| • Cyanide | • Tin |
| • Fluoride | • Titanium |
| • Gold | • Tungsten |
| • Hexachlorobenzene | • Zinc |
| • Iron | |

The data collection effort for Part 421 took place from 1979 to 1984, and the data were not updated for the 1990 final rule. EPA has not conducted any additional data collection efforts for this industry since that time.

5.3.2.3 Wastewater Characterization

There are over 240 types of process wastewater streams generated by the 31 regulated subcategories of the NFM manufacturing industry. Many of these wastewaters are associated with air pollution control treatment, contact cooling and quenching, casting, and wash and rinsing operations. (1)

Table 5-16 presents the top pollutants discharged by the industry based on information in the 1989 Final NFM Manufacturing TDD. Based on the 1989 TDD loading information and accounting for toxic pound equivalents, benzo(a)pyrene was a top constituent of concern and was regulated in the final rule under the Primary Aluminum Smelting Subcategory. During the sampling effort for the rule, benzo(a)pyrene was found above its analytical quantitation limit in 13 of 19 samples taken from 10 plants. Effluent concentrations ranged from 0.17 to 11.0 mg/l. Additionally, EPA determined that a concentration of 0.01 mg/l for benzo(a)pyrene was attainable using the rule's identified treatment technologies (lime precipitation followed by sedimentation and multimedia filtration). In settlement negotiations after promulgation, the Agency revised its statistical analysis of benzo(a)pyrene data to develop one-day maximum and monthly average treatment effectiveness concentrations as a basis for calculating mass discharge limits. The recalculated treatment effectiveness concentrations are 0.0337 mg/l maximum for any one day and 0.0156 mg/l maximum monthly average of daily values. The Agency also restricted the discharge allowance for benzo(a)pyrene to those streams that actually contain this pollutant. (3)

Stream-specific concentration data from PCS (for the 2000 reporting year) indicate that current discharges of benzo(a)pyrene are generally less than 0.02 mg/l for those facilities reporting its discharge, with only one facility reporting a discharge above 0.01 mg/l. These concentration data indicate that current discharges for this pollutant are generally below treatable levels.

Table 5-16 also presents the top pollutants discharged by the industry based on the estimated total TWPE load from both TRI and PCS (using the 2000 databases). The 2000 TRI TWPE was 978,450, with over 90 percent of the load coming from six direct discharging facilities. The 2000 PCS TWPE was 434,925, with over 90 percent of the load coming from 15 facilities.

Table 5-16. Top Pollutants Discharged by the NFM Manufacturing Industry

Data Source	Pollutant	Number of Facilities Reporting Pollutant	Regulated Pollutant?	Discharged Annual Loading ¹		Percentage of the Total TWPE Load
				TWPE	Pounds Per Year	
TDD	Benzo(a)pyrene	27	Yes	220,979	52	51%
	Arsenic	195	Yes	27,002	7,783	6%
	Silver	157	Yes	11,790	716	3%
	Aluminum	116	Yes	2,213	34,320	1%
	Ammonia as Nitrogen	163	Yes	1,161	771,510	0.27%
	Zinc	229	Yes	471	10,074	0.11%
PCS	Vanadium (total)	3	No	100,592	161,665	23.1%
	Benzo(a)pyrene	14	Yes	89,743	21	20.6%
	Chlorine (Total Residual)	25	No	84,373	173,257	19.4%
	Polychlorinated Biphenols (PCBs)	6	No	29,319	2	6.7%
	Fluoride (total)	27	Yes	21,321	609,188	4.9%
	Chlorine (Free Available)	19	No	14,524	29,825	3.3%
	Aluminum (total)	22	Yes	14,239	220,806	3.3%
	Zinc (total)	26	Yes	12,107	258,991	2.8%
TRI	Polycyclic Aromatic Compounds (PACs)	4	²	831,010	194	84.9%
	Vanadium Compounds	4	No	52,174	83,851	5.3%
	Sodium Nitrite	1	No	34,727	93,019	3.5%
	Cadmium Compounds	8	³	21,812	8,351	2.2%

¹Discharged annual loading from the TDD represents loading before application of the final regulations.

²Benzo(a)pyrene is a regulated pollutant; PACs as a group are not regulated. The TWF for benzo(a)pyrene was used as a representative toxic weighting factor (TWF) for the PACs category to calculate TWPE.

³Cadmium is a regulated pollutant; cadmium compounds as a group are not regulated.

Based on the 2000 PCS data, vanadium and benzo(a)pyrene are the top pollutants of concern for the NFM manufacturing industry. Vanadium is not currently a regulated pollutant, and benzo(a)pyrene is regulated under the Primary Aluminum Smelting Subcategory. Based on the 2000 TRI data, PACs are the pollutants of greatest concern and would include benzo(a)pyrene.

The pollutants generated by facilities in this category vary by subcategory and process. For this analysis, PCS and TRI data are available at the 4-digit SIC code level. Table 5-17 lists the pollutants with the highest total TWPE by SIC code from *TRIRelases2000* for both direct and indirect dischargers. Table 5-18 presents the same information for *PCSLoads2000* for major direct dischargers. EPA analyzed wastewater characterization data at the subcategory and segment levels for the 1990 rule, however, and are available in the supporting TDD (1).

**Table 5-17. Pollutants of Concern Identified in *TRIRelases2000*
(Direct and Indirect Dischargers)**

SIC Code	Pollutant	Number of Facilities Reporting Discharge	Pounds of Pollutant	TWPE	Percentage of TWPE (SIC Code)
2819	Mercury	1	4	468	99
3331	Silver Compounds	2	257	4,228	52
	Arsenic Compounds	2	258	894	11
	Selenium Compounds	1	750	840	10
	Cadmium Compounds	2	257	670	8
	Lead Compounds	2	257	575	7
3334	Polycyclic Aromatic Compounds	4	194	831,011	99
3339	Vanadium Compounds	1	60,260	37,495	49
	Sodium Nitrite	1	93,019	34,727	45
3341	Cadmium Compounds	2	7,852	20,510	36
	Vanadium Compounds	2	23,336	14,520	26
	Phosphorus (yellow or white)	2	401	6,648	12

Table 5-18. Pollutants of Concern Identified in PCS Database (Direct Dischargers)

SIC Code	Pollutant	No. Facilities Reporting Discharge	Pounds of Pollutant	TWPE	Percentage of TWPE (SIC Code)
2819	Aluminum (Total)	1	9,158	591	38
	PCBs	1	0.035	455	29
3331	Cadmium (Total Recoverable)	1	147	383	27
	Cadmium (Total)	1	143	374	26
	Zinc (Total Recoverable)	1	4,434	207	15
	Zinc (Dissolved)	2	4,285	200	14
	Lead (Total Recoverable)	1	79	176	12
3334	Benzo(a)pyrene	8	21	89,743	37
	Chlorine (Total Residual)	12	167,184	81,416	33
3339	Vanadium (Total)	2	142,237	88,503	65
	Chlorine (Free Available)	1	29,825	14,524	11
3341	PCBs	1	2.2	28,725	57
	Vanadium (Total)	1	19,428	12,088	24

5.3.2.4 Treatment Technologies

The 1990 rule based limitations on zero discharge for 3 of 31 subcategories. EPA based limitations for the remaining 28 subcategories on a variety of technologies, including oil skimming, chemical precipitation, sedimentation, and filtration. EPA based ammonia limitations on steam stripping for nine subcategories and on air stripping for the Secondary Molybdenum and Vanadium subcategory. Cyanide limitations were based on cyanide precipitation for four subcategories and molybdenum limitations were based on iron co-precipitation for three subcategories.

Table 5-19 presents the estimated reduction in pollutant loadings from raw wastewater to discharge based on the data in the 1989 TDD (1). These data indicate that the current treatment in the industry should be resulting in 99+ percent reductions for those pollutants regulated in the 1990 rule.

Table 5-19. NFM Manufacturing Category Pollutant Reductions

Pollutant Group Name	TDD Percent Removal
Direct Dischargers	
Total Conventional Pollutants	99.3%
Total Nonconventional Pollutants	99.7%
Ammonia	99.8%
Vanadium	99.7%
Total Priority Pollutants	99.7%
Benzo(a)pyrene	99.7%
Indirect Dischargers	
Total Conventional Pollutants	99.8%
Total Nonconventional Pollutants	99.2%
Ammonia	NA
Vanadium	NA
Total Priority Pollutants	99.9%
Benzo(a)pyrene	NA

Source: EPA, 1989 TDD.
 NA - Not available.

Table 5-20 presents the treatment technologies most commonly used by NFM manufacturing facilities reporting to TRI for 2000.

Table 5-20. Wastewater Treatment Operations Reported By NFM Manufacturing Facilities, TRI Reporting Year 2000

Wastewater Treatment Process	Number of Facilities Reporting Use	
	Direct (35 Facilities)	Indirect (27 Facilities)
Chemical Precipitation	33	30
Filtration	22	21
Settling/Clarification	25	15
Neutralization	16	12
Sludge Dewatering (Nonthermal)	9	6
Equalization	7	4
Stripping - Air or Steam	5	3
Adsorption	4	4
General Oxidation (including disinfection)	4	3

Source: Section 7A Table of the TRI 2000 Database.

The information on treatment technologies indicates that facilities reporting to TRI in 2000 continued to use technologies that formed the basis of the final rule but also used additional technologies, including adsorption, biological treatment, and chemical oxidation.

Over 50 percent of the NFM manufacturing facilities reporting to the 2000 TRI are zero dischargers. It is unknown whether there are best management practices (BMPs), pollution prevention practices, or other “dry” operations from these facilities that could be transferrable to other discharging facilities in similar subcategories. In addition, metals removal for this industry may be improved using multiple-stage metals precipitation or newer multimedia filtration followed by chemical precipitation technologies.

5.3.2.5 Conclusions

The NFM manufacturing industry ranks high in estimated toxic pollutant discharges among the industrial categories investigated in EPA’s screening-level analyses. These discharges are based on data reported to PCS and TRI. About half (54 percent) of the facilities classified in these SIC codes (using 1997 Economic Census data) provided chemical release data in TRI, while only 13 percent are major dischargers reporting surface water discharges in PCS.

Based on the 2000 TRI data, EPA attributes most of the reported loading, made up of PACs such as benzo(a)pyrene, to six facilities. From the data available in PCS, benzo(a)pyrene, vanadium, and chlorine (total residual) appear to be the pollutants of greatest concern based on TWPE discharges.

Concentration data from PCS (for the 2000 reporting year) indicate that current discharges of benzo(a)pyrene are generally below 0.01 mg/l for those facilities reporting its discharge. These concentrations are generally below treatable concentrations and additional reductions of this pollutant may not be possible.

The information from both *PCSLoads2000* and *TRIReleases2000* also indicate that the pollutants of concern (by SIC code) are, in most cases, being discharged by only one or two facilities. Therefore, while additional study of this industry is warranted based on the toxic loads discharged, the need for revised national regulations may not be warranted due to the number of facilities involved.

TRI data indicate a significant percentage (>50 percent) of facilities in this industry are zero dischargers. However, data are not currently available to assess whether the processes and BMPs used by the zero discharge facilities can be transferred to other facilities that discharge similar subcategory wastewaters. The last data collection effort for this industry occurred in the 1980s, and additional study of this industry would help EPA determine whether facilities can achieve additional reductions in the pollutants with the highest toxic pounds by applying existing BMPs or newer technologies. Therefore, EPA will continue to review this industry in the next planning cycle.

5.3.2.6 References

1. U.S. EPA. *Development Document for Effluent Limitations Guidelines and Standards for the Nonferrous Metals Manufacturing Point Source Category, Volume I*. EPA-440/1-89/019.1. Washington, D.C. May 1989.
2. U.S. Census Bureau. *1997 Economic Census*.
3. U.S. EPA. *Development Document for Effluent Limitations Guidelines and Standards for the Nonferrous Metals Manufacturing Point Source Category, Volume II*. EPA-440/1-89/019.2. Washington, D.C. May 1989.
4. U.S. EPA. *Development Document for Effluent Limitations Guidelines and Standards for the Nonferrous Metals Manufacturing Point Source Category, Volume III*. EPA-440/1-89/019.3. Washington, D.C. September 1986.

5.4 Group III Industries

This section provides information on the limited investigations EPA conducted on the Group III industries. During its screening-level review, EPA identified this group of industrial point source categories as having relatively high estimates of potential toxic-weighted pollutant discharges. However, EPA also identified numerous data gaps and issues that may affect the Agency's estimate of the potential hazard posed by discharges from these categories. EPA's review of these categories focused on filling in these data gaps to better inform EPA's decision-making. These categories are: Fertilizer Manufacturing (Part 418), Phosphate Manufacturing (Part 422), Ore Mining and Dressing (Part 440), Pulp and Paper (Part 430) Phase II, Steam Electric Power Generation (Part 423), Textile Mills (Part 410), and Timber Products Processing (Part 429).

5.4.1 **Fertilizer and Phosphate Manufacturing (Parts 418 and 422)**

The fertilizer manufacturing and phosphate manufacturing industries ranked high in terms of toxic and nonconventional pollutant discharges among industrial point source categories investigated in the screening-level analyses. Because of the potential for overlap of operations between these two point source categories, EPA evaluated the SIC codes related to these industries and the specific facilities to better classify facilities that perform fertilizer manufacturing operations versus phosphate manufacturing operations. EPA found that one facility contributes over 99 percent of the toxic-weighted load from phosphate manufacturing, and that fluoride discharges account for over 99 percent of that facility's discharge. EPA also found that one facility contributes 84 percent of the toxic-weighted load from fertilizer manufacturing and that fluoride discharges account for over 75 percent of that facility's discharge. This section summarizes the review of both point source categories.

5.4.1.1 Industry Description

The fertilizer manufacturing industry includes facilities that produce phosphorus- and nitrogen-based fertilizers. EPA divided the Fertilizer Manufacturing Point Source Category into seven subcategories based on the type of fertilizer produced. ELGS found in 40 CFR Part 418 are applicable to process wastewater and contaminated nonprocess wastewater discharged from the specific subcategories listed in Table 5-21. Facilities subject to this point source category typically report under SIC codes 2873 (Nitrogenous Fertilizers), 2874 (Phosphatic Fertilizers), and 2875 (Fertilizers, Mixing Only).

Table 5-21. Subcategories in the Fertilizer Manufacturing Point Source Category (Part 418)

Subpart	Title	Description
A	Phosphate Subcategory	Manufacture of sulfuric acid by sulfur burning, wet-process phosphoric acid, normal superphosphate, triple superphosphate, and ammonium phosphate.
B	Ammonia Subcategory	Manufacture of ammonia.
C	Urea Subcategory	Manufacture of urea.
D	Ammonium Nitrate Subcategory	Manufacture of ammonia nitrate.
E	Nitric Acid Subcategory	Production of nitric acid in concentrations up to 68 percent.
F	Ammonium Sulfate Production Subcategory	Production of ammonium sulfate by the synthetic process and by coke oven by-product recovery.
G	Mixed Blend Fertilizer Production Subcategory	Production of mixed ¹ and blend ² fertilizer.

¹Mixed fertilizer means “a mixture of wet and/or dry straight fertilizer material, mixed fertilizer materials, fillers and additives prepared through chemical reaction to a given formulation.”

²Blend means “a mixture of dry straight, and mixed fertilizer materials.”

The phosphate manufacturing industry includes facilities that produce phosphorus-related products. EPA divided the Phosphate Manufacturing Point Source Category into six subcategories based on the type of product. ELGS found in 40 CFR Part 422 are applicable to process wastewater and contaminated nonprocess wastewater discharged from the specific subcategories listed in Table 5-22. Facilities subject to this point source category typically report under SIC codes 2874 and 2819 (Industrial Inorganic Chemicals, not elsewhere classified).

Table 5-22. Subcategories in the Phosphate Manufacturing Point Source Category (Part 422)

Subpart	Title	Description
A	Phosphorus Production Subcategory	Production of phosphorus and ferrophosphorus by smelting of phosphate ore.
B	Phosphorus Consuming Subcategory	Manufacture of phosphoric acid, phosphorus pentoxide, phosphorus pentasulfide, phosphorus trichloride, and phosphorus oxychloride directly from elemental phosphorus.
C	Phosphate Subcategory	Manufacture of sodium tripolyphosphate, animal feed grade calcium phosphate, and human food grade calcium phosphate from phosphoric acid.
D	Defluorinated Phosphate Rock Subcategory	Defluorination of phosphate rock by applying high temperature treatment along with wet process phosphoric acid, silica, and other reagents (not in manufacturing).
E	Defluorinated Phosphoric Acid Subcategory	Defluorination of phosphoric acid. Wet process phosphoric acid is dehydrated by applying heat and other processing acids such as vacuum and air stripping. The acid is concentrated up to 70-73% P ₂ O ₅ in the defluorination process.
F	Sodium Phosphates Subcategory	Manufacture of purified sodium phosphates resulting from wet process phosphoric acid.

During EPA's initial screening-level review, facilities that reported SIC code 2874 (Phosphatic Fertilizers) were included as part of both the Fertilizer Manufacturing category and the Phosphate Manufacturing category. This resulted in double counting of the pollutant loads discharged by these facilities. EPA further reviewed operations at the top dischargers in SIC code 2874 to determine which category is most appropriate for their operations. Table 5-23 summarizes this review.

Similarly, facilities that reported SIC code 2819 were included as part of both the Phosphate Manufacturing category and the Inorganic Chemicals Manufacturing category. EPA further reviewed operations at the top dischargers in SIC code 2819 and confirmed that all operations were related to inorganic chemicals manufacturing. For the purposes of this review (and to avoid double counting pollutant loads), EPA then removed all facilities reporting SIC code 2819 from the Phosphate Manufacturing category, although it is possible some of these facilities also fall under the applicability of phosphate manufacturing.

Table 5-23. Review of Top Fertilizer and Phosphate Dischargers Reporting SIC 2874 as Primary SIC Code

Facility	Final Category Designation	Description
IMC Phosphates, Uncle Sam, LA	Phosphate Manufacturing	Produces phosphoric acid and hydrofluoric acid (covered under Subcategory D, Phosphate Manufacturing) and sulfuric acid by burning elemental sulfur (covered under Subcategory A, Fertilizer Manufacturing). This facility contributes over 99 percent of the toxic-weighted load from phosphate manufacturing, and fluoride discharges account for over 99 percent of this facility's discharge.
Mississippi Phosphates Corp., Pascagoula, MS	Fertilizer Manufacturing	Manufacture of sulfuric acid, phosphoric acid, and diammonia phosphate (covered under Subcategory A, Fertilizer Manufacturing).
Royster-Clark Inc, Hartsville, SC	Fertilizer Manufacturing	Facility purchases liquids (such as sulfuric acid or phosphoric acid) and other by-products and combines them in a rotary drum (covered under Subcategory G, Fertilizer Manufacturing). A reaction occurs and the result is granular homogenous fertilizer. Facility says primary SIC code is 2875.

Source: Facility telephone contact reports (2, 3, 4).

Fertilizer Manufacturing Process Descriptions (Part 418)

This section describes the manufacturing processes included in the Fertilizer Manufacturing category. It describes processes included in Subcategory A (Phosphate Fertilizers) to distinguish operations covered under phosphate manufacturing. Fertilizer is available in both liquid and dry forms, and either as a single type of plant nutrient or a mixed type. The industry identifies plant food content by the total percentage of nitrogen, phosphoric acid, and water soluble potassium available in the fertilizer. The production of two basic fertilizer ingredients, nitrogen (N) and phosphate (P_2O_5), is covered under Part 418. (1)

Phosphate Fertilizers (Subpart A)

Phosphoric acid (H_3PO_4) is produced by two commercial methods: wet process and thermal process. Wet process phosphoric acid is typically used to produce fertilizers and would then be covered under the Fertilizer Manufacturing category. Thermal process phosphoric acid is covered under the Phosphate Manufacturing category, and is discussed below. In a wet process facility, phosphoric acid is produced by reacting sulfuric acid with naturally occurring phosphate rock. The phosphate rock is dried, crushed, and then continuously fed into the reactor along with sulfuric acid. The reaction combines calcium from the phosphate rock with sulfate, forming calcium sulfate ($CaSO_4$), commonly referred to as gypsum. Gypsum is separated from the reaction solution by filtration. The production of wet process phosphoric acid generates a considerable quantity of acidic cooling water with high concentrations of phosphorus and fluoride. (8)

Sulfuric acid used in manufacturing fertilizers is typically produced at the phosphate fertilizer manufacturing facility using the contact process. First, elemental sulfur is burned in a furnace to produce sulfur dioxide, which is further oxidized using a catalyst surface to speed the oxidation reaction. The resulting sulfur trioxide is hydrolyzed with water to form sulfuric acid. (1)

Phosphate fertilizers are classified into three groups of chemical compounds. Two of these groups are known as superphosphates and are defined by the percentage of phosphorus as phosphorus pentoxide (P_2O_5). Normal superphosphates contain between 15 and 21 percent phosphorus as P_2O_5 and are prepared by reacting ground phosphate rock with 65 to 75 percent sulfuric acid. Triple superphosphate contains over 40 percent phosphorus and are prepared either by the “run-of-pile” process (identical to normal superphosphate, except phosphoric acid is used instead of sulfuric acid) or the granular triple superphosphate process. In the granular process, ground phosphate rock or limestone is reacted with phosphoric acid; however, the phosphoric acid used in this process is appreciably lower in concentration (40 percent P_2O_5) than that used in the run-of-pile process. The remaining phosphate fertilizer group is ammonium phosphate ($NH_4H_2PO_4$), which is produced by reacting H_3PO_4 with anhydrous ammonia (NH_3). (1)

Nitrogen Fertilizers (Subparts B through F)

NH_3 is one of the principal fertilizer materials and can be used directly as a fertilizer or as a source of nitrogen in other synthetic fertilizers. NH_3 is produced by the chemical reaction of hydrogen with nitrogen. Urea ($CO(NH_2)_2$), also known as carbamide, contains the highest percentage of nitrogen in solids fertilizers. It is produced by reacting ammonia with carbon dioxide to form ammonium carbamate, which is then dehydrated to form urea. Nitric acid is produced using anhydrous ammonia, air, water, and a catalyst. Ammonia is oxidized with air to form nitric oxide, which is further oxidized to form nitrogen dioxide. The gases are absorbed in water to produce nitric acid and nitric oxide. Ammonium nitrate is produced by neutralizing ammonia with nitric acid at high temperatures, which evaporates the water and some ammonia, leaving ammonium nitrate. (1) Synthetic ammonium sulfate is produced by combining anhydrous ammonia and sulfuric acid in a reactor. Coke oven by-product ammonium sulfate is produced by reacting the ammonia recovered from coke oven off-gas with sulfuric acid. (9)

Mixed and Blended Fertilizers (Subpart G)

Mixed fertilizers are a mixture of wet and/or dry straight fertilizer materials, fillers, and additives prepared through chemical reaction to a given formulation. Blended fertilizers are a mixture of dry, straight, and mixed fertilizer materials. (1)

Phosphate Manufacturing Process Descriptions (Part 422)

This section describes the manufacturing processes included in the Phosphate Manufacturing category that have potential overlap with processes covered under the Fertilizer

Manufacturing category: manufacture of phosphoric acid (Subcategory B) and defluorination of phosphoric acid (Subcategory D, E).

As discussed above, phosphoric acid (H_3PO_4) is produced by two commercial methods: wet process and thermal process. The wet process is typically used to produce phosphoric acid used in fertilizer manufacture, which is covered under Fertilizer Manufacturing (Part 418, Subpart A). The thermal process phosphoric acid, covered by Phosphate Manufacturing (Part 422, Subpart B) is of a much higher purity and is used in the manufacture of high-grade chemicals, pharmaceuticals, detergents, food and beverage products, and other nonfertilizer products. Raw materials to produce phosphoric acid by the thermal process are elemental (yellow) phosphorus, air, and water. Thermal process phosphoric acid manufacture involves three major steps: combustion, hydration, and demisting.

In combustion, the liquid elemental phosphorus is burned (oxidized) in ambient air in a combustion chamber at temperatures of 1,650 to 2,760°C (3,000 to 5,000°F) to form phosphorus pentoxide. The phosphorus pentoxide is then hydrated with dilute H_3PO_4 or water to produce strong phosphoric acid liquid (Reaction 3). Demisting, the final step, removes the phosphoric acid mist from the combustion gas stream before it is released to the atmosphere. This is usually done with high-pressure drop demisters. (7)

Concentration of H_3PO_4 produced from thermal process normally ranges from 75 to 85 percent. This high concentration is required for high-grade chemical production and other non-fertilizer-product manufacturing. Efficient plants recover about 99.9 percent of the elemental phosphorus burned as phosphoric acid. (7)

Defluorinated phosphate (DFP), also known as tricalcium phosphate (TCP), is produced from phosphate rock, phosphoric acid, and soda ash. This process, covered under Subpart D, can be broken down into three sections: feed preparation/mixing, defluorination (by calcining), and product sizing. Phosphate rock, phosphoric acid, and soda ash are blended in a batch or continuous mixer/reactor. The material is conveyed to a screening system that excludes oversize material that is milled and recycled. The product from the screen is sent to storage prior to feeding into the defluorination system. The second stage reactions take place in a large kiln (or fluidized bed) where the material is heated to approximately 2,800°F. DFP from the kiln is discharged through a cooler and cooled by air. The kiln is vented to a scrubber system that must handle a large load of fluoride vapors. Material from the cooler is transferred to the product-sizing area where screens, mills, and hoppers are used to classify and store the product prior to shipping. (9)

Newer processes have been developed to produce high-purity phosphoric acid using wet process phosphoric acid, covered under Subpart E. This procedure involves pretreating the feed acid to remove impurities through dearseniation and filtration, solvent extraction, stripping, reextraction, concentration of the acid, and defluorination (through stripping). (8)

Facility Counts

EPA obtained information on the number of facilities in the Fertilizer and Phosphate Manufacturing categories from three sources: the 1997 U.S. Economic Census, the *TRI Releases 2000*, and the *PCS Loads 2000*. TRI includes facilities reporting discharges to any media. In contrast, PCS includes only facilities that are permitted for discharge to surface waters. Table 5-24 lists the number of facilities from these sources. Approximately half of the facilities reporting to TRI in these categories collectively report no wastewater discharge of toxic chemicals.

Table 5-24. Number of Fertilizer and Phosphate Facilities

SIC Code	1997 Census	2000 PCS			2000 TRI				
		Total	Major	Minor	Total Reporting To TRI	No Reported Discharge	Direct Discharge	Indirect Discharge	Both Direct and Indirect Discharge
Fertilizer Manufacturing									
2873	143	40	25	15	63	21	38	1	3
2874	NA	1	1	0	2	0	1	0	1
2875	449	6	0	6	42	29	8	5	0
Total	592	47	26	21	107	50	47	6	4
Phosphate Manufacturing¹									
2874	61	22	14	8	31	19	12	0	0
Total	61	22	14	8	31	19	12	0	0

NA - Census totals for SIC code 2874 are included under Phosphate Manufacturing. As explained previously, EPA identified two facilities under this SIC code as part of Fertilizer Manufacturing (see Table 5-23).

¹Facilities reporting SIC code 2819 were included in the Inorganic Chemicals Manufacturing Point Source Category.

Fertilizer and phosphate manufacturing facilities are located throughout the United States, but there is a higher concentration in the Midwest and in the Southeast.

5.4.1.2 Regulatory Background

The current ELGS, summarized in Table 5-25, are codified at 40 CFR Part 418 and 422. Fluoride limitations for Subpart A of Fertilizer Manufacturing and Subparts D and E of Phosphate Manufacturing are the same. A number of subcategories require zero discharge of process wastewater pollutants, with some exceptions.

ELGS for the Fertilizer Manufacturing category are based on a combination of process changes, best management practices, and end-of-pipe technologies. For phosphate fertilizers (Subpart A), the primary source of contaminated process and nonprocess wastewater

discharged is overflow from gypsum ponds. Effluent concentrations are based on double lime neutralization of the pond water to reduce fluoride and phosphorus, and ponds designed to hold precipitation from a 10-year, 24-hour rainfall event (for BPT) or a 25-year, 24-hour rainfall event (for BAT). EPA considered, but did not promulgate, ammonia limits. Ammonia primarily occurs from equipment wash water. Ammonia concentrations can range from 25 to over 600 mg/L in gypsum ponds.

For nitrogen fertilizers (Subparts B through E), mass-based limitations are based on application of best management practices (including containment and reuse), ammonia steam stripping, hydrolysis, and oil/water separators. More stringent limitations are also based on process changes and other end-of-pipe technologies, including air stripping, biological nitrification/denitrification, and ion exchange.

For ammonium sulfate (Subpart F) and mixed and blended fertilizers (Subpart G), zero discharge limitations are based on manufacturing process controls, complete recycle and reuse of wastewaters, and dry air pollution control devices.

ELGS for the Phosphate Manufacturing category are based primarily on end-of-pipe treatment technologies. Similar to Subpart A of the Fertilizer Manufacturing category, the primary source of process and nonprocess wastewater discharged from facilities in Subparts D and E of the Phosphate Manufacturing category is overflow from containment and cooling ponds. Effluent concentrations limits are based on lime neutralization of cooling pond water, and ponds are designed to hold precipitation from a 10-year, 24-hour rainfall event (for BPT) or a 25-year, 24-hour rainfall event (for BAT).

For Subpart F, ELGS are based on double lime neutralization used to remove TSS, phosphate, radium-226, and fluoride. This process can lower fluoride levels from 9,000 mg/L to about 30 mg/L, and phosphorus levels from 6,500 mg/L to about 60 mg/L. (11) In some cases, modified forms of phosphate may be present in certain wastewaters, which can hinder the lime neutralization process. These wastewaters should undergo a hydrolysis pretreatment step. (11)

Table 5-25. Pollutants Regulated by Existing Fertilizer and Phosphate ELGS

Subpart	BPT	BAT	NSPS	PSES & PSNS	Mass- or Concentration-Based Limits
Fertilizer Manufacturing					
A ¹	Total phosphorus Fluoride TSS (process wastewater only)	Total phosphorus Fluoride	Same as BPT	No discharge of incompatible process wastewater pollutants	Concentration-based
B	Ammonia pH	Ammonia	Ammonia pH	PSNS set equal to NSPS	Mass-based

Table 5-25 (Continued)

Subpart	BPT	BAT	NSPS	PSES & PSNS	Mass- or Concentration-Based Limits
C	Ammonia Organic N	Ammonia Organic N	Same as BAT	PSNS set equal to NSPS	Mass-based
D	Ammonia Nitrate (as N)	Ammonia Nitrate (as N)	Same as BAT	PSNS set equal to NSPS	Mass-based
E	Ammonia Nitrate (as N)	Ammonia Nitrate (as N)	Same as BAT	PSNS set equal to NSPS	Mass-based
F	No discharge of process wastewater pollutants	No discharge of process wastewater pollutants	No discharge of process wastewater pollutants	PSNS: Ammonia (as N)	Concentration- based
G	No discharge of process wastewater pollutants	No discharge of process wastewater pollutants	No discharge of process wastewater pollutants	PSNS: Ammonia (as N) Total phosphorus Nitrate (as N)	Concentration- based
Phosphate Manufacturing					
A ²	None	None	None	None	
B ²	None	None	None	None	
C ²	None	None	None	None	
D ^{2,3}	Total phosphorus Fluoride TSS pH	Total phosphorus Fluoride	Same as BPT	None TDD says reserved; nothing in CFR	Concentration- based
E ³	Total phosphorus Fluoride TSS pH	Total phosphorus Fluoride	Same as BPT	None TDD says reserved; nothing in CFR	Concentration- based
F	Total phosphorus Fluoride TSS pH	Total phosphorus Fluoride	Total phosphorus Fluoride TSS pH	None TDD says reserved; nothing in CFR	Mass-based

Source: *Code of Federal Regulations*, <<http://www.epa.gov/epahome/cfr40.htm>>.

¹Subpart A: No discharge except calcium sulfate storage pile runoff. BPT = 10-year, 24-hour rainfall event and BAT = 25-year, 24-hour rainfall event.

²Subcategories A-C have applicability defined in the regulation. However, there are no limitations or standards.

³Subparts D-E: No discharge of process wastewater except for cooling water recirculation systems designed, constructed, and operated to maintain surge capacity equal to the runoff from the 10-year, 24-hour rainfall event (BPT) (25-year for BAT).

5.4.1.3 Wastewater Characteristics and Pollutant Sources

This section presents wastewater sources and characteristics as determined from TRI and PCS data.

Wastewater Discharge

Most major facilities reporting to PCS report discharge outfall flow rates. Table 5-26 presents the total annual flow (in millions of gallons per year (MGY)) for 2000, median annual discharge flow, and the range of annual flows for fertilizer and phosphate facilities. Facilities not reporting a flow were not included in the median calculation. Data presented in Table 5-26 are based on major dischargers reporting to PCS for 2000. One facility in each category accounts for the majority of total flow reported for each point source category.

Table 5-26. 2000 Wastewater Flows for Fertilizer and Phosphate Facilities

Point Source Category	Number of Major Facilities Reporting Nonzero Flows	Median Facility Flow 2000 (MGY)	Range of Facility Flows 2000 (MGY)	Total Flow 2000 (MGY)
Fertilizer Manufacturing	24	394	26 - 703,349	912,489
Phosphate Manufacturing	11	291	3 - 62,856	99,827

Source: PCSLoads2000.

Pollutants

Table 5-27 lists the pollutants reported to PCS, which account for 95 percent of the total TWPE for fertilizer and phosphate manufacturing facilities that reported discharges to PCS by major dischargers for 2000. Table 5-28 lists the pollutants reported to TRI as discharged directly or indirectly, which account for 95 percent of the total TWPE for fertilizer and phosphate manufacturing facilities that reported to TRI for 2000. This table presents the number of facilities that reported each chemical, total pounds of chemical discharged, and total TWPE for each chemical. Note that information provided in Tables 5-27 and 5-28 reflect information as reported to TRI or PCS.

The pollutant contributing most of the TWPE from phosphate manufacturing facilities is fluoride. Fluoride is a component of phosphate rock, used in the production of phosphoric acid. The vast majority of fluoride (>99 percent) reported discharged in 2000 came from one facility covered under Subpart D, Deflourinated Phosphate Rock. This facility is in compliance with their current NPDES permit and discharges fluoride in once-through cooling water and stormwater at concentrations of about 50 to 60 mg/L¹.

¹BAT limitations for fluoride discharges from cooling water recirculation systems are 75 mg/L daily maximum and 25 mg/L monthly average.

Table 5-27. Fertilizer and Phosphate Pollutant Discharges Reported by Major Facilities to PCS for 2000

Pollutant	Number of Facilities Reporting	PCS Total (lbs/yr)	PCS TWPE/yr	Median Facility TWPE/yr	Range of Facility TWPE/yr	Percentage of Total SIC Code TWPE	Cumulative Percentage of Total SIC Code TWPE
Fertilizer Manufacturing							
Fluoride, Total (as F)	3	2,188,701	76,605	2330	90 - 74,184	66%	66%
Aluminum, Total (as Al)	1	346,681	22,357	NA	NA	19%	85%
Iron, Total (as Fe)	1	1,631,865	9,138	NA	NA	8%	93%
Nitrogen, Ammonia Total (as N)	25	3,483,296	6,375	90	0.4 - 1,595	5%	98%
Totals	26	508,665,081	116,464				
Phosphate Manufacturing							
Fluoride, Total (as F)	14	31,243,823	1e+06	255	14 - 1,080,892	99.8%	99.8%
Total	14	110,978,734	1e+06				

Source: EPA, PCSLoads2000.

NA - Not applicable; only one facility reported this pollutant.

Table 5-28. Fertilizer and Phosphate Chemical Releases to Surface Water Reported to TRI for 2000

Pollutant	Number of Facilities Reporting	TRI Total (lbs/yr)	TRI TWPE/yr	Median Facility TWPE/yr	Range of Facility TWPE/yr	Percentage of Total SIC Code TWPE	Cumulative Percentage of Total SIC Code TWPE
Fertilizer Manufacturing							
Chromium Compounds	2	14,030	7,181	3,591	10 - 7,171	32%	32%
Dioxin and Dioxin-like Compounds ¹	2	0.01	6,626	3,313	384 - 6,242	29%	61%
Copper Compounds	11	3,011	1,888	160	3 - 754	8%	70%
Chlorine	9	3,725	1,814	67	2 - 519	8%	78%
Manganese Compounds	7	24,056	1,694	18	0 - 1,414	8%	85%
Zinc Compounds	13	33,523	1,567	12	0 - 796	7%	92%
Ammonia	48	522,929	787	4.1	0 - 83	3%	96%
Totals	107	5,498,199	22,566				
Phosphate Manufacturing							
Ammonia	12	15,113	22.8	0.4	<1 - 12	70%	70%
Zinc Compounds	1	105	4.9	NA	NA	15%	85%
Manganese Compounds	1	66	4.7	NA	NA	14%	99%
Total	31	18,427	32.5				

Source: EPA, TRIReleases2000.

NA - Not applicable; only one facility reported this pollutant.

¹ EPA estimated the TWPE for dioxin using the congener distributions reported to TRI. For facilities that did not report a distribution, EPA used an average distribution reported by facilities in this point source category.

The primary pollutants contributing most of the TWPE for fertilizer manufacturing facilities include fluoride, metal compounds, ammonia, and dioxin and dioxin-like compounds. With the exception of ammonia, these pollutants are reported as discharged by a few facilities. Ammonia was discharged by over half of the facilities in PCS and nonzero dischargers reporting to TRI. The primary pollutants contributing to the TWPE as reported to TRI are metal pollutants and dioxin and dioxin-like compounds. Over half of the TWPE reported is attributed to a few facilities. Note that 2000 was the first year that facilities were required to report dioxin discharges to TRI. Based on information from this review, many facilities report dioxin discharges at a concentration equal to half of the method detection limit and most do not sample their effluents for dioxin.

5.4.1.4 Pollutant Prevention and Treatment Technology

Table 5-29 lists the treatment technologies most commonly used by fertilizer and phosphate manufacturing facilities reporting to TRI for 2000.

Table 5-29. Wastewater Treatment Operations Reported By Fertilizer and Phosphate Manufacturing Facilities, TRI Reporting Year 2000

Wastewater Treatment Process	Number of Fertilizer Facilities Reporting Use		Number of Phosphate Facilities Reporting Use
	Direct Dischargers (22 facilities)	Indirect Dischargers (1 facility)	Direct Dischargers (5 facilities)
Neutralization	9	1	2
Equalization	6	1	-
Settling/Clarification	4	1	2
Biological Treatment	6	-	-
Steam Stripping	4	-	-
Other Chemical Treatment	3	-	1
Oil Skimming	3	1	-
Chemical Precipitation - Lime or Sodium Hydroxide	1	-	2
Other Physical Treatment	2	-	-
Other Treatment	3	-	2

Source: EPA, Section 7A Table of the TRI 2000 Database.

5.4.1.5 Industry Trends

The Census Bureau released preliminary results of the 2002 economic census on a subsector basis. The Chemical Manufacturing subsector, classified under North American Industrial Classification System (NAICS) code 325, includes establishments that manufacture basic chemicals and establishments that transform organic and inorganic raw materials by a chemical process and formulate the materials into intermediate and end products. This NAICS subsector includes:

- Basic chemical manufacturing;
- Resin, synthetic rubber, and artificial and synthetic fibers and filaments manufacturing;
- Pesticide, fertilizer, and other agricultural chemical manufacturing;
- Pharmaceutical and medicine manufacturing;
- Paint, coating, and adhesive manufacturing;
- Soap, cleaning compound and toilet preparation manufacturing; and
- Other chemical product manufacturing.

Thus, NAICS code 325 includes more than just the fertilizer and phosphate manufacturing industries. The trends shown below over the period 1997 - 2002 represent the entire subsector and may not be comparable for the fertilizer and phosphate manufacturing industries. Chemical manufacturing sales increased over the five-year period while the number of establishments declined, and employment dropped by 10 percent.

Trends in U.S. Chemical Manufacturing Industry

	1997	2002
Establishments	13,474	13,107
Sales	\$415 billion	\$427 billion
Paid Employees	883 thousand	790 thousand

Source: 2002 Economic Census, <http://www.census.gov/econ/census02/advance/TABLE2.HTM>.

5.4.1.6 Stakeholder and EPA Regional Issues

During EPA's outreach effort, some stakeholders suggested that the fertilizer manufacturing ELGS are outdated and do not seem to be sufficiently stringent. During previous outreach efforts, stakeholders in Oklahoma noted concerns related to ammonia discharges in this

industry. Based on the information presented in Section 5.4.1.3 concerning wastewater discharges, EPA concludes that only a few facilities discharge the majority of TWPE load from these industries. However, ammonia was discharged by over half of the facilities in PCS and nonzero dischargers reporting to TRI.

5.4.1.7 Conclusions

Pollutants with the highest TWPE reported to TRI and PCS for 2000 are fluoride, metal compounds, ammonia, dioxin, and dioxin-like compounds for fertilizer manufacturing facilities and fluoride for phosphate manufacturing facilities.

For phosphate manufacturing, a single facility, which is in compliance with its permit limits, contributes greater than 99 percent of the reported fluoride discharges. Consequently, based on the information available at this time, EPA concludes the phosphate manufacturing ELGs do not need additional study at this time.

For fertilizer manufacturing, with the exception of ammonia, only a few facilities contribute the majority of the TWPE. Over half of the facilities in PCS and nonzero dischargers reporting to TRI reported discharging ammonia. EPA plans to further evaluate its methodology for considering ammonia and nitrogen compound discharges.

5.4.1.8 References

1. U.S. EPA. *Industrial Technology Division Rulemaking Summary, Category: Fertilizer Manufacturing*, 40 CFR Part 418. Washington, D.C. No Date.
2. Telephone conversation with Russell G. Oliver of IMC Phosphates, Uncle Sam, LA, and Bob Southworth of ERG. "SIC Code for Uncle Sam and Faustina Facilities." November 18, 2003.
3. Telephone conversation with Jim Smith of Mississippi Phosphate Corp, Pascagoula, MS, and Arash Hooshangi of ERG. "Clarification of Manufacturing Processes and Pollutant Discharges." January 16, 2004.
4. Telephone conversation with Billy Pirkle of Royster-Clark, Hartsville, SC, and Arash Hooshangi of ERG. "Clarification of Manufacturing Processes and Pollutant Discharges." January 16, 2004.
5. Australian Government. *Emission Estimation Technique Manual for Inorganic Chemicals Manufacturing, Version 2.0*. Department of the Environment and Heritage. 2004. Available online at: http://www.npi.gov.au/handbooks/approved_handbooks/pubs/inorganic-chemical.pdf.

6. Australian Government. Emission Estimation Technique Manual for Ammonium Sulfate Manufacturing, Version 2.0. Department of the Environment and Heritage. 2004. Available online at: http://www.npi.gov.au/handbooks/approved_handbooks/pubs/fammsulf.pdf.
7. U.S. EPA. *Compilation of Air Pollutant Emission Factors, AP-42, Fifth Edition, Volume I: Stationary Point and Area Sources, Chapter 8: Inorganic Chemical Industry*. Washington, D.C. 1988. Available online at: <http://www.epa.gov/ttn/chief/ap42/ch08/>.
8. Vichem. "Phosphoric Acid Purification." 2004. Available online at: <http://www.vichem.fr/apurifacidphos.htm>
9. KEMWorks Technology, Inc. *Animal Feed Ingredients: Defluorinated Phosphate Rock (DFP)*. 2004. Available online at: http://www.kemworks.com/Animal_Nutrition.htm
10. U.S. EPA. *Development Document for Effluent Limitations Guidelines and New Source Performance Standards for the Phosphorus Derived Chemicals Segment of the Phosphate Manufacturing Point Source Category*. EPA-440/1-74-006-a. Washington, D.C. January 1974.
11. U.S. EPA. *Development Document for Effluent Limitations Guidelines and New Source Performance Standards for the Other Non-Fertilizer Phosphate Chemicals Segment of the Phosphate Manufacturing Point Source Category*. EPA-440/1-75/043-a. Washington, D.C. June 1976.
12. U.S. EPA. *Development Document for Effluent Limitations Guidelines and New Source Performance Standards for the Basic Fertilizer Chemicals Segment of the Fertilizer Manufacturing Point Source Category*. EPA-440/1-74-011-a. Washington, D.C. March 1974.
13. U.S. EPA. *Development Document for Effluent Limitations Guidelines and New Source Performance Standards for the Formulated Fertilizer Chemicals Segment of the Fertilizer Manufacturing Point Source Category*. EPA-440/1-75/042-a. Washington, D.C. January 1975.

5.4.2 Ore Mining and Dressing

5.4.2.1 Industry Description

Regulations in 40 CFR Part 440 for the Ore Mining and Dressing Point Source Category apply to discharges from facilities that are engaged in the mining, milling, or preparing of 23 separate metal ores. Metal ore mining is conducted by a variety of methods, such as

surface mining, underground mining, and in situ mining. Surface mining operations include quarrying, open pit, open cut, open cast, stripping, placarding, and dredging. Underground mining, which is used primarily for lead and zinc ores, is carried out through shafts. In situ mining, or solution mining, includes leaching of uranium and copper. Metals are separated from less valuable material (gangue) in milling processes. Methods of extraction include gravity concentration, magnetic separation, electrostatic separation, floatation, and leaching. Leaching involves processes such as amalgamation, cyanidation, solvent extraction, and ion exchange. Chemicals used in separation processes, in particular the reagents used in froth floatation, are the primary source of toxic organic pollutants for this industry. This industry is divided into nine SIC codes, as shown in Table 5-30.

EPA obtained information on the number of facilities in the Ore Mining and Dressing category from three sources: the 1997 U.S. Economic Census, the *TRIReleases2000*, and *PCSLoads2000*. Table 5-30 lists the number of ore mining and dressing facilities by SIC code from these sources. The number of facilities reporting to TRI for 2000 represent only about 14 percent of the ore mining and dressing industry based on the total number of facilities in the census, while the number of major dischargers reporting to PCS represent about 11 percent of the number of facilities in the census.

Table 5-30. Number of Ore Mining and Dressing Facilities

SIC Code	1997 U.S. Economic Census	2000 TRI - All Dischargers	2000 PCS	
			Major Dischargers	Minor Dischargers
1011 Iron Ores	32	NA	5	5
1021 Copper Ores	49	19	11	2
1031 Lead and Zinc Ores	31	19	23	6
1041 Gold Ores	300	40	18	14
1044 Silver Ores	16	5	1	5
1061 Ferroalloy Ores	NR	7	6	1
1081 Metal Mining Services	203	NA	0	1
1094 Uranium-Radium-Vanadium Ores	29	NA	10	13
1099 Metal Ores, Not Elsewhere Classified	36	6	3	4
Total	696	96 (14%)	77 (11%)	51 (7%)

Source: U.S. Economic Census, 1997; *TRIReleases2000*; *PCSLoads2000*.

NA - Facilities in this SIC code are not required to report to TRI.

NR - No facilities are reported in this SIC code.

Of the 96 ore mining and dressing facilities in *TRIReleases2000*, Table 5-31 presents the number and percentage of facilities by type of discharge. According to available

data in TRI 2000, no ore mining and dressing facilities reported both direct and indirect discharges. Over half of the facilities reporting to TRI indicated no wastewater discharge. Of those that discharge, almost all are direct dischargers (39 of 41).

Ore mining and dressing facilities are geographically concentrated in the western states and Alaska.

Table 5-31. Number of Ore Mining and Dressing Facilities by Discharge Type (TRI 2000)

SIC Code	Direct Dischargers Only		Indirect Dischargers Only		No Reported Wastewater Discharge	
	Number	Percentage of All Facilities in SIC Code	Number	Percentage of All Facilities in SIC Code	Number	Percentage of All Facilities in SIC Code
1021	8	42%	0	0%	11	58%
1031	18	95%	0	0%	1	5%
1041	6	15%	2	5%	32	80%
1044	3	60%	0	0%	2	40%
1061	2	43%	0	0%	4	57%
1099	1	17%	0	0%	5	83%
Total	39 (41%)		2 (2%)		55 (57%)	

Source: EPA, *TRIRelases2000*.

Sources of wastewater for ore mining and dressing facilities include:

- Spillage from thickeners; lubricants and floatation agents;
- Transport water; and
- Leaching processes.

5.4.2.2 Regulatory Background

The ELGS for this industry are codified under 40 CFR Part 440. Subcategories are based on the metal being extracted, the differences between mine and mill wastewater, and the type of mill process. Climate, rainfall, and location were considered in determining if any subcategories could achieve zero discharge. Mines located in arid regions can effectively reduce effluent discharge quantities by evaporation. Other facilities, located in areas with net positive precipitation or icy conditions, have less control over their discharge volumes.

The final regulation was promulgated in 1982. BPT limitations are based on lime precipitation and settling. For BAT, EPA also considered adding secondary settling, flocculation, or granular media filtration as the technology basis. EPA further considered

secondary settling because it was the least expensive of these three options. EPA analyzed plant data from facilities using secondary settling, and determined that nationally applicable regulations based on secondary settling were not necessary for the following reasons:

- BPT removes at least 95 percent of the relevant pollutants;
- The only environmentally significant pollutants remaining after stream flow dilution are cadmium and arsenic, and no appreciable reduction of these pollutants was observed with secondary settling; and
- The BPT limitations for the Ore Mining and Dressing category are more stringent than BAT limitations for other industries in 1982.

BAT ELGS are set at BPT levels for toxic pollutants. The toxic pollutants regulated by BAT for this industry in at least one subcategory are cadmium, copper, lead, mercury, and zinc. Table 5-32 presents the pollutants regulated by ELGS for each ore mining subcategory.

Process wastewater for this industry includes any water used in the mill or in the ancillary operations required for beneficiating the ore, and contacting the ore, processing chemicals, intermediate products, by-products or products of a process, including contact cooling water.

Table 5-32. Ore Mining and Dressing Pollutants Regulated by Existing Effluent Limitations Guidelines and Standards

40 CFR Part	Subcategory	BPT	BAT	NSPS
440.10	Iron Ore	TSS, Dissolved Fe, pH	Dissolved Fe	TSS, Dissolved Fe, pH
440.20	Aluminum Ore	TSS, Fe, Al, pH	Total Fe, Al	TSS, Fe, Al, pH
440.30	Uranium, Radium, & Vanadium Ores	TSS, COD, Zn, Ra226 (dissolved), Ra226 (total), U, pH	COD, Zn, Ra226 (dissolved), Ra226 (total), U	TSS, COD, Zn, Ra226 (dissolved), Ra226 (total), U, pH
440.40	Mercury Ore	TSS, Hg, Ni, pH	Hg	TSS, Hg, pH
440.50	Titanium Ore	TSS, Fe, pH, Zn, Ni	Fe, Zn	TSS, Fe, pH, Zn
440.60	Tungsten Ore	TSS, Cd, Cu, Zn, Pb, As, pH	Cd, Cu, Zn	Cd, Cu, Zn, pH, TSS
440.70	Nickel Ore	TSS, Cd, Cu, Zn, Pb, As, pH	Reserved	Reserved
440.80	Vanadium Ore	TSS, Cd, Cu, Zn, Pb, As, pH	Reserved	Reserved
440.90	Antimony Ore	Reserved	Reserved	Reserved

Table 5-32 (Continued)

40 CFR Part	Subcategory	BPT	BAT	NSPS
440.100	Copper, Lead, Zinc, Gold, Silver, Molybdenum Ores	TSS, Cu, Zn, Pb, Hg, Cd, pH	Cu, Zn, Pb, Hg, Cd	TSS, Cu, Zn, Pb, Hg, Cd, pH
440.110	Platinum Ore	Reserved	Cu, Zn, Pb, Hg, Cd	Reserved
440.140	Gold Placer Mines	Settleable Solids	Settleable Solids	Settleable Solids

Source: *Code of Federal Regulations* <<http://www.epa.gov/epahome/cfr40.htm>>.

5.4.2.3 Wastewater Characteristics

Of the 77 major facilities reporting to PCS, 57 (74 percent) report information on discharge outfall flow rates. Table 5-33 presents the total annual flow (in million gallons) for 2000, median annual discharge flow, and range of annual flows for each SIC code. Facilities not reporting a flow were not included in the median calculation. Data presented in Table 5-33 are based on major dischargers reporting to PCS for 2000. Iron ore mines (SIC code 1011) had the largest median facility flow, while copper ores (SIC code 1021) had the lowest median facility flow. However, for uranium, radium, and vanadium ores (SIC code 1094), 8 of 10 facilities reported zero flows. The total number of facilities reporting wastewater flows to PCS for 2000 accounts for about 12 percent of the Ore Mining and Dressing industry based on 1997 Economic Census, and thus may not characterize the entire industry.

Table 5-33. 2000 Wastewater Flows for Ore Mining and Dressing Facilities

SIC Code	1997 U.S. Economic Census	Number of Major Facilities Reporting Nonzero Flows	Median Facility Flow 2000 (MGY)	Range of Facility Flows (MGY)	Total Flow 2000 (MGY)
1011	32	5	2,455	2-48,680	1,000,173
1021	49	5	2	0.003-5,051	351,130
1031	31	20	350	38-6,548	587,837
1041	300	16	398	2-3,797	567,185
1044	16	1	553	NA	553
1061	NR	5	732	84-8,096	184,542
1094	29	2	72	3-142	5,129
1099	36	3	1,372	275-1,607	17,732
Total	493	57			2,714,281

Source: EPA, *PCSLoads2000* and 1997 U.S. Economic Census.

NR - None reported.

Table 5-34 presents the chemicals reported to TRI for 2000 as discharged directly or indirectly that account for 95 percent of the total TWPE for each SIC code. This table presents

the number of facilities that reported each chemical, total pounds of chemical discharged for each SIC code, and total TWPE for each chemical. Iron ore mines, metal mining service facilities, and uranium-radium-vanadium ore mines (SIC codes 1011, 1081, 1094) are not required to report to TRI.

Table 5-34. Ore Mining and Dressing Chemical Releases to Surface Water Reported to TRI for 2000

SIC Code	Pollutant	Number of Facilities Reporting	TRI Total (lbs/yr)	TRI TWPE/yr	Median Facility TWPE/yr	Range of Facility TWPE/yr	Percentage of Total SIC Code TWPE	Cumulative Percentage of Total SIC Code TWPE
1021	Silver Compounds	1	255	4,200	4,200	NA	49%	49%
1021	Copper Compounds ^R	6	1,777	1,114	1,114	NA	13%	62%
1021	Arsenic Compounds	1	255	885	885	NA	10%	72%
1021	Cadmium Compounds ^R	1	255	666	666	NA	8%	80%
1021	Lead Compounds ^R	2	256	573	287	2-571	7%	87%
1021	Selenium Compounds	1	255	286	286	NA	3%	90%
1021	Thallium Compounds	1	255	255	255	NA	3%	93%
1021	Nickel Compounds	2	1,701	185	93	0-185	2%	95%
1031	Lead Compounds ^R	11	6,062	13,579	571	29-8,590	61%	61%
1031	Manganese Compounds	3	73,700	5,191	6	1-5,184	23%	84%
1031	Copper Compounds ^f	9	1,571	985	82	7-320	4%	88%
1031	Zinc Compounds ^R	17	21,027	983	35	0-219	4%	92%
1031	Cadmium Compounds ^R	5	324	846	31	8-713	4%	96%
1041	Arsenic Compounds	4	4,374	15,175	1,993	87-11,102	89%	89%
1041	Sodium Nitrite	1	1,955	730	730	NA	4%	93%
1041	Copper Compounds ^R	2	516	324	162	129-194	2%	95%
1044	Lead Compounds ^R	3	819	1,835	591	34-1,210	43%	43%
1044	Arsenic Compounds	2	326	1,131	566	212-919	27%	70%
1044	Silver Compounds	2	32	527	264	247-280	12%	82%
1044	Manganese Compounds	3	5,122	361	106	82-173	9%	91%
1044	Mercury Compounds ^R	1	2	234	234	NA	6%	97%
1061	Lead	1	117	262	262	NA	82%	82%
1061	Manganese Compounds	2	654	46	23	0-46	14%	96%
Total		41	491,249	52,627				

Source: *TRI Releases 2000*.

^R - Pollutants that are currently regulated by ELGS.

NA - No range was calculated because only one facility reported a nonzero release.

Information in Table 5-34 shows that for some SIC codes (such as 1021 and 1041) and many of the pollutants listed, the pollutants are primarily attributed to a handful of discharging facilities. However, of the chemical releases reported to TRI for 2000, the following

pollutants are the major contributors to the total TWPE (52,627 lb-eq/yr) for ore mining and dressing facilities:

- Lead in SIC code 1031 (lead and zinc ores) accounts for 26 percent of the ore mining TWPE and is discharged by just over half of the facilities reporting to TRI in this SIC code; and
- Arsenic in SIC code 1041 (gold ores) accounts for 29 percent of the ore mining TWPE, which is reported as discharge by only 10 percent of facilities reporting to TRI in this SIC code.

Lead is regulated under 40 CFR Part 440 by BPT and BAT for mining activities in the following SIC codes:

- 1021 - Copper ores;
- 1031 - Lead and zinc ores;
- 1041 - Gold ores;
- 1044 - Silver ores; and
- 1061 - Ferroalloy ores (molybdenum).

In developing the ELGS for the Ore Mining and Dressing category, EPA concluded that limitations on copper, lead, zinc, and mercury would ensure adequate control of arsenic (1). Arsenic is, therefore, not specifically regulated under the existing rule.

Table 5-35 lists the pollutants reported to PCS for 2000, which account for 95 percent of the total TWPE for each SIC code.

Table 5-35. Ore Mining and Dressing Pollutant Discharges Reported to PCS for 2000

SIC Code	Pollutant	Number of Facilities Reporting	PCS Total (lbs/yr)	PCS TWPE/yr	Median Facility TWPE/yr	Range of Facility TWPE/yr	Percentage of Total SIC Code TWPE	Cumulative Percentage of Total SIC Code TWPE
1011	Molybdenum, Total (as Mo)	1	819,646	165,108	165,108	NA	96%	96%
1021	Copper, Total (as Cu)	3	14,166	8,881	4,440	443-8,438	67%	67%
1021	Arsenic, Total (as As)	2	576	2,000	2,000	NA	15%	82%
1021	Zinc, Total (as Zn)	3	15,129	707	354	134-573	5%	87%
1021	Cadmium, Total (as Cd)	4	196	513	256	227-285	4%	91%
1021	Cyanide, Total (as Cn)	3	412	444	444	NA	3%	94%
1021	Lead, Total (as Pb)	2	127	285	285	NA	2%	96%

Table 5-35 (Continued)

SIC Code	Pollutant	Number of Facilities Reporting	PCS Total (lbs/yr)	PCS TWPE/yr	Median Facility TWPE/yr	Range of Facility TWPE/yr	Percentage of Total SIC Code TWPE	Cumulative Percentage of Total SIC Code TWPE
1031	Mercury Total Recoverable	3	641	75,044	75,044	NA	52%	52%
1031	Cadmium, Total (as Cd)	15	19,025	49,694	17	3-49,205	35%	87%
1031	Lead, Total Recoverable	9	5,128	11,487	1,091	71-4,989	8%	95%
1041	Arsenic, Total Recoverable	10	1,083	3,757	164	6-1,896	59%	59%
1041	Manganese, Total Recoverable	6	8,416	593	166	11-250	9%	68%
1041	Aluminum, Total Recoverable	3	5,025	324	78	66-180	5%	73%
1041	Silver, Total Recoverable	9	19	312	53	18-240	5%	78%
1041	Copper, Total Recoverable	11	485	304	11	132-304	5%	83%
1041	Cyanide, Weak Acid, Dissociable	11	275	296	21	0-253	5%	88%
1041	Lead, Total Recoverable	11	60	135	8	1-73	2%	90%
1041	Selenium, Total Recoverable	9	105	118	17	1-41	2%	92%
1041	Zinc, Potentially Dissolved	3	2,183	102	38	0-64	2%	94%
1041	Cadmium, Total Recoverable	11	28	73	3	0-56	1%	95%
1041	Zinc, Total Recoverable	11	1,298	61	8	1-23	1%	95%
1044	Arsenic, Total Recoverable	1	11	39	39	NA	93%	93%
1044	Copper, Total Recoverable	1	2	1	1	NA	2%	95%
1061	Molybdenum, Total (as Mo)	3	131,433	26,476	13,238	457-26,018	56%	56%
1061	Fluoride, Total (as F)	2	203,918	7,137	3,569	76-7,062	15%	
1061	Manganese, Potentially Dissolved	1	93,362	6,567	6,576	NA	14%	80%
1061	Manganese, Total Recoverable	3	64,645	4,553	2,277	98-4,455	10%	95%
1061	Cyanide, Total (as Cn)	3	557	600	600	NA	1%	95%
1094	Manganese, Total (as Mn)	2	659	46	46	NA	47%	47%
1094	Selenium, Total (as Se)	9	40	44	44	NA	45%	92%
1094	Copper, Total Recoverable	1	10	7	7	NA	7%	99%
1099	Iron, Total Recoverable	3	7,508	42	11	2-29	100%	100%
Total		77	110,515,980	383,560				

Source: EPA, PCSLoads2000.

NA - No range was calculated because only one facility reported a nonzero release.

Of the major facility discharges from the Ore Mining and Dressing category, the following pollutants are the major contributors to the total PCS TWPE (383,560 lb-eq/yr):

- Molybdenum accounts for 43 percent of the ore mining TWPE and is discharged by a single facility in SIC code 1011 (Iron Ores);
- Mercury accounts for 20 percent of the ore mining TWPE and is discharged by approximately 10 percent of the facilities in SIC code 1031 (Lead and Zinc Ores);
- Cadmium accounts for 13 percent of the ore mining TWPE and is discharged by approximately 56 percent of the facilities in SIC code 1031 (Lead and Zinc Ores); and
- Molybdenum accounts for 7 percent of the ore mining TWPE and is discharged by 25 percent of the facilities in SIC code 1061 (Ferroalloy Ores).

Cadmium and mercury are regulated under 40 CFR Part 440 by BPT and BAT in several subcategories, including the mining activities in the following SIC codes:

- 1021 - Copper Ores;
- 1031 - Lead and Zinc Ores;
- 1041 - Gold Ores;
- 1044 - Silver Ores; and
- 1061 - Ferroalloy Ores (Molybdenum).

Molybdenum was not among the pollutants identified for control in the 1982 Development Document (1), and thus is not regulated in any ore mining subcategory. Molybdenum has not been historically regulated in ELGS. Data collected for recent ELGS development for other industries demonstrates that molybdenum removal requires precipitation and solid/liquid separation at a pH unique to molybdenum. (3)

Table 5-36 lists the pollutants from Tables 5-34 and 5-35 with the highest TWPE that are not currently regulated under 40 CFR Part 440.

Table 5-36. Ore Mining and Dressing Top Pollutants Reported to TRI and PCS for 2000 That Are Not Regulated Under 40 CFR Part 440

Pollutant	TRI TWPE/yr	Percentage of Total TRI TWPE/yr ¹	PCS TWPE/yr	Percentage of Total PCS TWPE/yr ²	Reason for Exclusion from ELGS	Additional Information
Molybdenum	NR ³	NR ³	191,584	50%	Not identified for control.	Only 4 facilities report discharge of this pollutant; requires precipitation at a unique pH.
Arsenic	16,174	31%	3,796 ⁴	0.99%	Limits on Cu, Pb, Zn, & Hg effectively control releases of this pollutant.	Primarily reported in both TRI and PCS from SIC code 1041 facilities.
Manganese	5,353	10%	6,578 ⁵	1.7%	Not identified for control.	Generally not regulated in ELGs because it can be used as a treatment chemical.
Silver	4,315	8.2%	312 ⁶	0.081%	Detected at levels too low for treatment by known technologies.	Over 97% of TWPE reported by a single facility in SIC code 1021.

Source: Development Document for Effluent Limitations Guidelines and Pretreatment Standard, 1982; *TRIReleases2000*; *PCSLoads2000*.

¹The total TWPE for all ore mining and dressing facilities reporting to TRI for 2000 is 52,627 lb-eq/yr.

²The total TWPE for all ore mining and dressing facilities reporting to PCS for 2000 is 383,560 lb-eq/yr.

³Molybdenum discharges are not required to be reported to TRI.

⁴The discharge of arsenic represents the amount reported to PCS as arsenic, total recoverable.

⁵The discharge of manganese represents the amount reported to PCS as manganese, potentially dissolved.

⁶The discharge of silver represents the amount reported to PCS as silver, total recoverable.

EPA also attempted to determine how effective this regulation has been by comparing previously collected data to the 2000 TRI and PCS data. In 1977, EPA began a series of sampling and analysis programs to identify pollutants of concern in the ore mining and dressing industry, placing an emphasis on toxic pollutants. These programs in support to the existing regulations included:

- Screen Sampling Program (20 facilities);
- Verification Sampling Program (14 facilities);
- Verification Monitoring Program (3 facilities);
- EPA Regional Offices Surveillance and Analysis Program (15 facilities);
- Cost Site Visit Program (7 facilities);
- Uranium Study (5 mines and 5 mills);
- Gold Placer Mining Study (11 mines);
- Titanium Sand Dredging Mining and Milling Study (3 facilities); and
- Solid Waste Study (6 subcategories).

The results of these nine sampling programs are as follows:

- Out of 129 toxic organic pollutants, 29 were detected in treated wastewater;
- All 13 toxic metals were detected in wastewater; and
- Cyanide and asbestos were observed in many samples.

Table 5-37 compares the results of wastewater sampling presented in the 1982 Development Document (1) with counts of facilities reporting discharges of the 13 toxic metals and cyanide to TRI and PCS for 2000. Because only facilities with permit limits report to PCS and only facilities above thresholds report to TRI, the PCS and TRI counts are minimum estimates of facilities discharging wastewater containing these metals. No new pollutants were identified for this industry after reviewing the 2000 TRI and PCS data.

Table 5-37. Toxic Metals in Ore Mining Wastewater

Chemical	1982 Development Document # Detects / # Samples	TRIRelases2000¹ Number of Facilities Reporting Chemical	PCSLoads2000² Number of Facilities Reporting Chemical
Antimony	6/82	4	1
Arsenic	106/114	7	6
Beryllium	43/84	0	1
Cadmium	54/106	7	34
Chromium	70/85	5	5
Copper	100/103	17	28
Cyanide	24/68	4	18
Lead	70/86	15	24
Mercury	54/87	2	34
Nickel	70/86	6	2
Selenium	58/84	2	13
Silver	29/84	2	1
Thallium	3/82	1	2
Zinc	106/106	23	38

Source: EPA, Development Document for Effluent Limitations Guidelines and Standards, 1982 (1); *TRIRelases2000*; *PCSLoads2000*.

¹96 facilities reported wastewater discharges to TRI for 2000.

²77 major dischargers reported to PCS for 2000.

In general, this information suggests the number of ore mining and dressing facilities discharging these toxic metals in process wastewater decreased substantially after promulgation of the ore mining and dressing ELGS.

Stormwater

EPA staff in Region 9 expressed a concern over high concentrations of metals in active and inactive mine site runoff that are violating water-quality standards. In particular, they cited arsenic, copper, mercury, and selenium. These discharges are currently considered industrial stormwater discharges and are not subject to ELGS. EPA analyzed information reported to TRI to determine if the reported polluted releases originated from stormwater. TRI requires facilities that monitor stormwater runoff pollutant concentrations to report the percentage of the total quantity of pollutant released to a receiving stream contributed by stormwater. Stormwater discharges are reported to Section 5 of TRI as a percentage of a total stream discharge. Table 5-38 compares the surface water releases of pollutants to the amount of discharge attributed to stormwater runoff at ore mining and dressing facilities.

Table 5-38. Ore Mining and Dressing Stormwater Discharges Reported to TRI for 2000

SIC	Chemical	Annual Discharge			Stormwater			Percent Pounds of Reported Annual Discharge From Stormwater
		Number of Facilities Reporting	Pounds	TWPE	Number of Facilities Reporting	Pounds	TWPE	
1021	Lead Compounds	2	256	573	1	1	2.2	0.39%
1021	Manganese Compounds	3	352	25	2	87	6.1	25%
1021	Nickel Compounds	2	1,701	185	1	1	0.11	0.06%
1021	Zinc Compounds	3	1,917	90	1	97	4.5	5.0%
1021	Copper Compounds	6	1,777	1,114	3	15	9.4	0.84%
1031	Zinc Compounds	17	21,027	983	8	3,037	142	14%
1031	Cadmium Compounds	5	324	846	2	52	136	16%
1031	Copper Compounds	9	1,371	985	2	53	34	3.5%
1031	Lead Compounds	11	6,062	13,579	2	70	157	1.2%
1031	Mercury Compounds	1	3	351	1	0.0003 0	0.035	0.010%

Table 5-38 (Continued)

SIC	Chemical	Annual Discharge			Stormwater			Percent Pounds of Reported Annual Discharge From Stormwater
		Number of Facilities Reporting	Pounds	TWPE	Number of Facilities Reporting	Pounds	TWPE	
1041	Manganese Compounds	5	1,298	91	1	2	0.14	0.15%
1061	Lead	1	117	262	1	117	262	100%
1061	Barium	1	109	0.22	1	109	0.22	100%
1061	Manganese Compounds	2	654	262	1	4	0.28	0.11%

Source: EPA, *TRI Releases 2000*.

Note: Of the 96 facilities that reported surface water discharges, 14 facilities attributed a percentage of their discharge to stormwater runoff.

None of the arsenic or selenium releases reported to TRI were identified as originating from stormwater. The total mercury TWPE from stormwater is 0.035 lb-eq/year, which accounts for 0.005 percent of the total mercury TWPE reported to TRI by ore mining and dressing facilities. The total copper TWPE from stormwater is 42.92 lb-eq/year, which accounts for 1.7 of the total copper TWPE reported to TRI by ore mining and dressing facilities. Stream descriptions are not provided for stormwater, so it is not possible to determine what percentage of the discharges are from waste rock and overburden piles. Except for one facility in SIC code 1061 (Ferrous Ores), the percentage of reported TWPE/yr identified as stormwater discharges was 25 percent or less.

These stormwater discharges are currently subject to industrial stormwater discharge requirements contained in EPA's Multi-Sector General Permit (MSGP) for Industrial Activities Sector G for Metal Mining. The MSGP establishes benchmark monitoring for pollutants such as TSS, pH, arsenic, beryllium, cadmium, copper, iron, lead, manganese, mercury, nickel, selenium, silver, zinc, and uranium. While facilities should be monitoring these discharges, there is no central repository for these monitoring data. Many mines are subject only to the stormwater permit and do not report to TRI or PCS. Consequently, for this review, EPA does not have adequate information to assess whether or not stormwater discharges associated with this industry are a significant source of pollution. Benchmark monitoring information supplied by the affected states and/or facilities is necessary to evaluate these discharges further.

5.4.2.4 Pollution Prevention and Treatment Technology

Most direct discharging ore mining and dressing facilities use settling or precipitation treatment. Of the 41 facilities reporting either direct or indirect discharges to TRI for 2000, 23 facilities provided information on their wastewater treatment operations. Table 5-39 lists the treatment technologies used by ore mining and dressing facilities reporting to TRI for 2000.

Table 5-39. Wastewater Treatment Operations Reported By Ore Mining and Dressing Facilities, TRI Reporting Year 2000

Wastewater Treatment Process	Number of Facilities Reporting Use	
	Direct Dischargers ¹ (22 facilities)	Indirect Dischargers ¹ (1 facility)
Settling/Clarification	20	0
Chemical Precipitation	7	0
Biological Treatment	4	0
Adsorption	3	0
Cyanide Oxidation	2	1
Filtration	2	0
Other Physical Treatment	2	1

Source: EPA, Section 7A Table of the TRI 2000 Database.

¹In TRI 2000, of the facilities that provided information on their wastewater treatment operations, 22 facilities reported direct releases, 1 reported transfers to POTWs, and no facilities reported both direct releases and transfers to POTWs.

For this study, EPA did not evaluate any pollution prevention or treatment methods to control pollutant discharges from stormwater discharges from ore mining and dressing facilities. However, EPA Region 9 suggests the following should be considered to control stormwater discharges:

- Reclamation of waste rock or overburden and tailing piles (regrading and restoration to natural contours); and/or
- Containment of stormwater through grading, berms, retention ponds (e.g., designed to contain 100-year, 24-hour storm).

EPA did not evaluate the costs or the effectiveness of these suggestions for this review.

5.4.2.5 Industry Trends

Table 5-40 compares the ore mining and dressing industry as presented in the 1982 TDD (1) with 2000 TRI data and 1997 Economic Census data. In this 15-year period, the number of mining facilities increased by 7 percent. The percentage of facilities that did not discharge wastewater may have increased, but this conclusion is based on information from the limited number of facilities that reported to TRI.

Table 5-40. Comparison of Ore Mining and Dressing Facilities in 1982 and 2000

Total Number of Facilities	Direct Dischargers	Indirect Dischargers	No Discharge
650 (1982)	67%	0%	33%
696 ¹ (1997)	41% ²	2% ²	57% ²

Source: Development Document for Effluent Limitations Guidelines and Standards, 1982 (1); U.S. Economic Census, 1997 (2); *TRIRelases2000*.

¹Number of ore mining and dressing facilities identified in 1997 Economic Census.

²Percentage of the 96 total facilities reporting to TRI in 2000.

5.4.2.6 Stakeholder and EPA Regional Issues

Stakeholders and EPA Regional staff submitted the following comments regarding the Ore Mining and Dressing category:

- The current ELGS may be outdated and the BAT technology basis may no longer be appropriate.
- The current ELGS should be revised to address discharges from waste rock, spent ore, and leach material. Other issues that need to be addressed include closure/financial assurance plans, remediation, and a definition of active versus inactive mines.
- The recommendations of EPA's National Mining Team, which include water budgets and closure plans, should be considered when revising the hard rock mining ELGS.
- The decision to exclude seepage from the waste dumps from the 40 CFR Part 440 definition of mine drainage should be reversed.
- Discharges from waste rock and overburden piles should be subject to the ELGS and should not be considered industrial stormwater, which is not subject to guidelines. Pollutants of concern in the discharges include arsenic, copper, mercury, and selenium.

5.4.2.7 Conclusions

Pollutants with the highest TWPE in TRI and PCS for 2000 are metals, which are naturally associated with the ores being mined. Cadmium, copper, lead, mercury, and zinc are regulated by BAT, BPT, and NSPS under existing regulations.

In TRI, lead and arsenic contribute the most TWPE for this industry (over 60 percent). In PCS, molybdenum, mercury, and cadmium contribute the most TWPE for the industry (over 80 percent). As explained above, lead, cadmium, and mercury are regulated by this ELGS. Molybdenum is not regulated, only reported by four facilities, and requires chemical precipitation at a unique pH. Arsenic was not regulated under the existing rule because it was determined to be adequately controlled through regulation of other metals. This pollutant was primarily reported in a single SIC code 1041.

The number of facilities reporting to TRI for 2000 represent only about 14 percent of the ore mining and dressing industry based on the total number of facilities in the 1997 Economic Census, while the number of major dischargers reporting to PCS represent about 11 percent of the industry. Consequently, the reported pollutant discharges may or may not accurately characterize the entire industry. Other data limitations and quality concerns include:

- Outfall descriptions are not included in *PCSLoads2000*, and must be obtained on a per-facility basis from PCS; and
- Few facilities report percent stormwater discharges in TRI, and it is difficult to compare TRI discharges from stormwater with other surface water discharges.

During review of this regulation, EPA Regional staff raised concerns about metal pollutants associated with stormwater discharges. EPA does not have sufficient information on these discharges to evaluate them. These discharges are generally subject to benchmark monitoring in stormwater permits (e.g., Multi-Sector Stormwater General Permits) rather than ELGS requirements. More specific monitoring data on stormwater discharges from mines would be necessary to determine the extent of metal discharges from waste rock and overburden piles. Monitoring data for stormwater permits are not easily obtained since records of any monitoring data provided by mining operations are, in most instances, maintained at the state level. EPA did not contact any facilities directly because it did not identify any reported discharges to TRI or PCS as being uncharacteristic for the industry. In the next annual review, EPA will continue to obtain and consider information to fill remaining data gaps.

5.4.2.8 References

1. U.S. EPA. *Development Document for Effluent Limitations Guidelines and Standards for the Ore Mining and Dressing Point Source Category*. EPA-440/1-82/061. Washington, D.C. 1982.

2. U.S. Economic Census. 1997. Available online at: <http://www.census.gov/epcd/www/econ97.html>.
3. U.S. EPA. *Federal Register* (Volume 68, Number 245), 40 CFR Part 437 [FRL-7601-3] RIN 2040-AD95, “Effluent Limitations Guidelines, Pretreatment Standards, and New Source Performance Standards for the Centralized Waste Treatment Point Source Category.” December 22, 2003, pp. 71014-71026.

5.4.3 Pulp, Paper, and Paperboard Phase II

5.4.3.1 Industry Description

Paper is composed of cellulose fibers and nonfibrous additives, felted together into a uniform sheet. In the U.S., the most common fiber source is wood, followed by recovered waste paper. Pulp is the term used for the fibrous material produced chemically and/or mechanically from wood or other cellulosic materials. Paperboard is thick paper, nominally with thickness greater than 0.3 mm. For statistical purposes, the U.S. Government divides the pulp, paper, and paperboard industry into three parts, each assigned a 4-digit SIC code:

- 2611 Pulp Mills - Establishments that make pulp from wood or other materials and whose primary product shipped is pulp.
- 2621 Paper Mills - Establishments whose primary product is paper. Integrated facilities that make both pulp and paper are included in this SIC code if they primarily ship paper or paper products. Thus, some facilities in SIC code 2621 make paper from purchased pulp while others make pulp and paper at the same site.
- 2631 Paperboard Mills - Establishments whose primary product is paperboard. Again, integrated facilities that make both pulp and paperboard are included in this SIC code if they primarily ship paperboard or paperboard products.

ELGS for the Pulp, Paper, and Paperboard Point Source Category are codified at 40 CFR Part 430. As discussed in Section 5.4.3.2, EPA divided the category into 12 subcategories based on the primary sources of wastewater pollutants. These subcategories do not correspond to the SIC codes. For example, the regulations in Subpart B (Bleached Papergrade Kraft and Soda) apply to discharges resulting from production of bleached kraft market pulp (SIC code 2611), integrated production of bleached kraft pulp and paper (SIC code 2621), or integrated production of bleached kraft pulp and paperboard (SIC code 2631).

EPA's Phased Approach for Reviewing Pulp and Paper Effluent Guidelines

Phase I. In 1988, a legal suit brought by the Environmental Defense Fund and National Wildlife Federation resulted in a consent decree obligating EPA to address discharges of dioxins and furans from 104 bleaching pulp mills, including nine dissolving pulp mills². At the same time it addressed the dioxin and furan issues at these 104 mills, EPA chose to review the ELGS for the entire Pulp, Paper, and Paperboard category. On December 17, 1993, EPA proposed a new subcategorization scheme and revised regulations for all 12 new subcategories. In a 1996 Notice of Data Availability (July 1996), EPA announced that it would promulgate final ELGS for the Pulp, Paper, and Paperboard category in stages. EPA first addressed Subparts B (Bleached Papergrade Kraft and Soda) and E (Papergrade Sulfite), because these subparts applied to the majority of the 104 mills identified in the consent decree. Revised ELGS for Subparts B and E were promulgated April 15, 1998, and became known as Pulp, Paper, and Paperboard Phase I. The new subcategorization scheme was also promulgated at this time.

Phase III. EPA proposed ELGS addressing discharges of dioxins and furans for the two dissolving pulp subcategories (Subpart A, Dissolving Kraft, and Subpart D, Dissolving Sulfite) in 1993. However, EPA did not promulgate regulations for these two subcategories in 1998 because EPA anticipated that the final ELGS for these subcategories would be based on different technologies than those that served as the basis for the proposed ELGS, and because affected companies were undertaking multi-year laboratory studies and mill trials to develop alternative bleaching technologies (61 FR 36835, July 1996). More recently, EPA determined it will not promulgate revised regulations for Phase III because there are only four affected facilities in these two subcategories (as of July 2004): two in Florida and one each in Georgia and Washington. Instead, EPA will support NPDES permit writers as they develop ELGS for dissolving pulp mills.

Phase II. The remaining eight subcategories, listed below, compose Phase II:

- Subpart C. Unbleached Kraft Subcategory;
- Subpart F. Semi-Chemical Subcategory;
- Subpart G. Mechanical Pulp Subcategory;
- Subpart H. Nonwood Chemical Subcategory;
- Subpart I. Secondary Fiber Deink Subcategory;
- Subpart J. Secondary Fiber Non-Deink Subcategory;

²Five of these dissolving pulp mills remained in operation in 2000, but one has since closed.

- Subpart K. Fine and Lightweight Papers From Purchased Pulp Subcategory; and
- Subpart L. Tissue, Filter, Non-Woven and Paperboard From Purchased Pulp Subcategory.

In 1993, EPA proposed revised BPT and NSPS for control of conventional pollutant discharges from these eight subcategories. EPA did not propose ELGS for dioxins and furans because they were not identified as pollutants of concern in discharges from these subcategories. In 1996, EPA planned to promulgate ELGS for the Phase II subcategories after promulgating the final rules for the Phase I subcategories. However, in the Effluent Guidelines Program Plan for 2002/2003 (67 FR 55012-55014, August 27, 2002), EPA announced it was *not* including revision of ELGS for the eight Phase II subcategories. Instead, EPA announced it would decide whether to move forward with regulatory development for the Phase II subcategories during its 2004 annual review.

Number and Discharge Status of Phase II Mills

As listed in Table 5-41, the 1997 U.S. Economic Census reports the total number of establishments in the pulp, paper and paperboard industry by SIC code.

Table 5-41. Number of Pulp, Paper, and Paperboard Establishments

SIC Code	Description	1997 U.S. Economic Census
2611	Pulp Mills	39
2621	Paper Mills	256
2631	Paperboard Mills	217
Total		512

Source: 1997 U.S. Economic Census.

Of the 512 facilities identified by the 1997 Census, 232 (45 percent) reported releases to TRI in 2000 and 291 were included in PCS. EPA classified each mill as Phase I, Phase II, or Phase III, based on information reported by mills in EPA's 1990 survey of the pulp, paper, and paperboard industry. In this survey, mills reported production by subcategory (5). The name and operations of the mills as of 2000 were confirmed by consulting Lockwood-Post's Directory of the Pulp, Paper and Allied Trades (4). Mills with any operations in Phase I subcategories were identified as Phase I, though wastewater generated by part of their production may be subject to ELGS for Phase II subcategories. By definition, the production at mills with operations in the Phase III subcategories does not overlap with other subcategories.

Table 5-42 presents the distribution of the 232 TRI-reporting facilities, by SIC code and regulatory review phase. Note that 78 facilities reported to TRI a primary SIC code of 2611 (pulp mills), while the census only identified 39 facilities in SIC code 2611. This

discrepancy might result from the differences in identification of the SIC code at integrated mills. The census based primary SIC code on value of shipments, while the TRI primary SIC code might be based on the primary source of toxic chemical releases. Thus, integrated mills are identified as SIC code 2621 (paper) or 2631 (paperboard) in the census, but might be identified as SIC code 2611 (pulp) in TRI, because pulping is the source of more toxic releases. Of the mills reporting to TRI for reporting year 2000, the majority (139, or 60 percent) are in regulatory review Phase II.

Table 5-42. Pulp and Paper Mills Reporting to TRI for Reporting Year 2000

SIC Code	Total	Phase I	Phase II	Phase III
2611	78	51	22	5
2621	109	30	79	0
2631	45	7	38	0
Total (%)	232	88 (38)	139 (60)	5 (2)

Source: EPA, *TRIRelases2000*.

Of the 512 facilities identified by the 1997 Census, 255 (50 percent) were mills classified as “major dischargers” whose 2000 discharges were reported to PCS. In addition to these major dischargers, PCS identified another 36 minor dischargers in the three pulp and paper SIC codes. Table 5-43 presents the distribution of PCS reporting facilities, by SIC code and regulatory review phase. Note that 86 major discharge mills were identified in PCS with a primary SIC code of 2611 (pulp mills), while the census only identified 39 facilities in SIC code 2611. Similar to the TRI database, this discrepancy might result from the differences between identification of the source of pollutants (e.g., pulping) and the product shipped from integrated mills. Of the major discharge mills with 2000 discharge data in PCS, the majority (172, or 67 percent) are in regulatory review Phase II.

Table 5-43. Pulp and Paper Mills with Data in PCS

SIC Code	Total		Phase I		Phase II		Phase III	
	Major Dischargers	Minor Dischargers	Major Dischargers	Minor Dischargers	Major Dischargers	Minor Dischargers	Major Dischargers	Minor Dischargers
2611	86	6	36	1	46	5	4	0
2621	125	23	35	0	90	23	0	0
2631	44	7	7	0	36	7	1	0
Total	255	36	78	1	172	35	5	0

Source: EPA, *PCSLoads2000*.

Table 5-44 presents discharge information about the Phase II mills from *TRIRelases2000* and *PCSLoads2000*. All mills that reported to TRI reported wastewater

releases of toxic chemicals. The majority (107 mills or 78 percent) reported at least some releases of toxic chemicals directly to receiving streams.

Table 5-44. Phase II Mills

PCS			TRI				
Total	Major Dischargers	Minor Dischargers	Total Reporters	No Reported Discharge	Direct Discharge	Indirect Discharge	Both Direct and Indirect Discharge
207	172	35	139	0	103	32	4

Source: EPA, *PCSLoads2000* and *TRIRelases2000*.

5.4.3.2 Regulatory Background

EPA promulgated BPT regulations for the Pulp, Paper, and Paperboard category from 1974 to 1982. Using data from the early to mid-1970s, EPA divided the industry into 25 subcategories. BPT limitations for BOD₅, TSS, and pH for all subcategories, including those that are now “Phase II,” was based on the performance (percent removal) of biological wastewater treatment, subcategory raw waste loads, and characteristic production-normalized effluent flow rates. During the industry review leading to the 1993 proposal of revised regulations, EPA determined that its original subcategorization scheme could be simplified to 12 subcategories. EPA also determined that the average performance of the industry, in terms of conventional pollutants discharged, had improved markedly from the time the original regulations were promulgated. In 1993, EPA proposed revised BPT and NSPS regulations for conventional pollutants for all 12 new subcategories. However, in 1996, EPA determined that it would not revise BPT for the Pulp, Paper, and Paperboard category and has taken no further action on the proposal since that time.

In 1982, EPA promulgated BAT ELG for trichlorophenol and pentachlorophenol for 24 subcategories (all but the then existing groundwood-chemi-mechanical subcategory). The priority pollutant zinc was limited in four groundwood subcategories.

During the development of the 1993 proposed regulations, EPA studied 443 specific pollutants (5). Although the focus of EPA’s study was revising the BAT ELG for chemical pulp mills that bleach, EPA also investigated the generation of chlorinated organic pollutants at nonchemical pulp mills and chemical nonwood pulp mills (mills that were later classified as Phase II) that bleach with chlorine and/or hypochlorite. EPA found levels of chloroform, chlorinated phenolic compounds, and dioxins in the final effluents from these mills. EPA did not propose ELGS for these priority and nonconventional pollutants in Phase II subcategories in 1993, but did not exclude the subcategories from regulation. EPA decided to consider whether to develop regulations for these pollutants as part of its 2004 annual review. Table 5-45 presents the existing limitations for Phase II subcategories.

Table 5-45. ELGS for Pulp, Paper, and Paperboard Phase II Subcategories (Part 430)

Subpart	BPT - Monthly Average Maximum		NSPS - Monthly Average Maximum	
	BOD ₅	TSS	BOD ₅	TSS
	<i>pounds per 1,000 lb of product</i>			
C - Unbleached Kraft	2.8	6.0	1.8-2.71 ¹	3.0-4.8
C - Unbleached Kraft and Semi-chemical Cross Recovery (Reserved)	4.0	6.25	2.1	3.8
F - Semi-chemical, Ammonia	4.0	5.0	1.6	3.0
F - Semi-chemical, Sodium	4.35	5.5	1.6	3.0
G - Groundwood Chem-mechanical	7.05	10.65	--	--
G - Groundwood Thermomechanical	5.55	8.35	2.5	4.6
G - Groundwood, Integrated, Coarse Paper	3.9	6.85	2.5	3.8
G - Groundwood, Integrated Fine Paper	3.6	6.3	1.9	3.0
H - Nonwood	reserved	reserved	reserved	reserved
I - Secondary Fiber Deink, Fine Paper	9.4	5.3	3.1	4.6
I - Secondary Fiber Deink, Tissue Paper	9.4	5.3	5.2	6.8
I - Secondary Fiber Deink, Newsprint	9.4	5.3	3.2	6.3
J - Secondary Fiber Non-deink, Paperboard	1.5	2.5	1.4	1.8
J - Secondary Fiber Non-deink, Paperboard and Corrugating Medium	2.8	4.6	2.1	2.3
J - Secondary Fiber Non-deink, Builders Paper and Roofing Felt	3.0	3.0	0.94	1.4
J - Secondary Fiber Non-deink, Tissue	4.0	5.1	2.5	5.3
J - Secondary Fiber Non-deink, Molded Products	1.3	3.2	1.1	2.3
K - Non-integrated, Fine Paper	4.25	5.9	1.9	2.3

Table 5-45 (Continued)

Subpart	BPT - Monthly Average Maximum		NSPS - Monthly Average Maximum	
	BOD ₅	TSS	BOD ₅	TSS
	<i>pounds per 1,000 lb of product</i>			
K - Non-integrated, Fine Paper, Cotton Furnish	9.1	13.1	4.2	4.9
K - Non-integrated, Lightweight Paper	13.2	10.6	6.7	5.2
K - Non-integrated, Electrical Paper	20.9	16.7	11.7	9.2
L - Non-integrated, Tissue	6.25	5.0	3.4	2.6
L - Non-integrated, Filter and Nonwoven	16.3	13.0	8.3	6.6
L - Non-integrated, Paperboard	3.6	2.8	1.9	1.5

¹The range of values represent limits for different size operations.

5.4.3.3 Wastewater Characteristics and Pollutant Sources

This subsection presents wastewater flow and pollutant load information reported to PCS and TRI for the year 2000. Also discussed are results of EPA sampling at five deink mills, and the basis of mill estimates of PACs releases reported to TRI.

Wastewater Flows

Of the 172 mills for which information was reported to PCS, 168 reported nonzero flows in 2000. Table 5-46 presents the median mill flow and the range of per mill flows for Phase II mills that are major dischargers. Wastewater flow information was not available for minor dischargers. In some cases, the reported flows may include stormwater discharges and noncontact cooling water, as well as process wastewater.

Table 5-46. 2000 Wastewater Flows for Phase II Mills (All SIC Codes)

Number of Major Dischargers Reporting Nonzero Flows	Median Per Mill Flow 2000 MGY (MGD)	Range of Mill Flows MGY (MGD)	Total Flow 2000 MGY (MGD)
168	1,400 (3.8)	0.0008 to 49,000 (<0.00 to 13)	660,000 (1,800)

Source: EPA, *PCSLoads2000*.

Wastewater Pollutant Loads from TRI and PCS

Table 5-47 presents information reported to TRI for reporting year 2000 by Phase II mills. The table lists the chemicals that account for 97 percent of the TWPE, the number of facilities that reported each chemical, and the total pounds of chemical discharged to surface waters. Indirect discharging facilities reported transfers to POTWs. Using average POTW removal efficiencies, EPA estimated the amount of pollutant discharged to surface water (see DCN 00618, *Evaluation of RSEI Model Runs*, for more information). Therefore, the TWPE estimates in this table have been adjusted to account for POTW treatment. PACs contribute 80 percent of the Phase II TWPE. As discussed later in this section, Phase II mills may have over-reported PAC and dioxin releases to TRI. Table 5-48 shows that manganese compounds and chlorine contribute 68 percent of the Phase II TWPE when PACs and dioxins are not included in the analysis.

Table 5-49 presents information about Phase II mills' calendar year 2000 discharges, reported to PCS. The table lists the chemicals that account for 95 percent of the total TWPE. Total residual chlorine and aluminum contribute 69 percent of the Phase II TWPE.

Wastewater Pollutant Loads from EPA Sampling

In 2000, EPA undertook a sampling program at five mills in the Secondary Fiber Deink Subcategory, one of the eight Phase II subcategories (1). EPA sampled mills with stand-alone deink operations that produce tissue and toweling, including two mills that use chlorinated bleaching agents and three mills that do not. Table 5-50 presents the production-normalized loads of selected analytes detected in treated mill effluent.

Other than a low concentration of phenol detected at one mill, the only organic priority pollutant detected in treated mill effluent was chloroform. EPA analyzed effluent samples for several PACs, but none were detected. With the exception of zinc, which was detected at concentrations ranging from 0.194 to 0.256 mg/L in the Mill 1 final effluent, the few priority pollutant metals detected in treated mill effluent were present at less than 0.035 mg/L. PACs and dioxins and furans, reported to TRI in Phase II mill wastewater releases, were not detected above the analytical method detection limit in treated wastewater during this study.

Table 5-47. Pulp and Paper Phase II Chemical Releases Reported to TRI for 2000

Pollutant	Number of Facilities Reporting	TRI Total (lbs/yr)	TRI TWPE/yr	Median Facility TWPE/yr	Range of Facility TWPE/yr	Percentage of Total Phase II TWPE	Cumulative Percentage of Total Phase II TWPE
Polycyclic Aromatic Compounds	12	113	484,471	32,340	8,567 to 77,104	80%	80%
Manganese Compounds	36	790,947	55,709	1,268	2 to 5,589	9%	89%
Chlorine	10	48,903	23,815	550	2.4 to 10,714	4%	93%
Potassium Dimethyldithiocarbamate	2	23,529	21,960	10,980	9,701 to 12,259	4%	96%
Dioxin and Dioxin-like Compounds	12	0.0047	7,480	36	0.18 to 5,296	1%	97%
Total All Pollutants	139	5,677,680	608,875				

Source: EPA, *TRI Releases 2000*.**Table 5-48. Pulp and Paper Phase II Chemical Releases Reported to TRI for 2000 Without PACs or Dioxins**

Pollutant	Number of Facilities Reporting	TRI Total (lbs/yr)	TRI TWPE/yr	Median Facility TWPE/yr	Range of Facility TWPE/yr	Percentage of Total Phase II TWPE	Cumulative Percentage of Total Phase II TWPE
Manganese Compounds	36	790,947	55,709	1,268	2 to 5589	48%	48%
Chlorine	10	48,903	23,815	550	2.4 to 10,714	20%	68%
Potassium Dimethyldithiocarbamate	2	23,529	21,960	10,980	9,701 to 12,259	19%	87%
Vanadium Compounds	7	6,314	3,929	622	182 to 1,121	3%	90%
Zinc Compounds	26	80,615	3,769	77	0.9 to 1,117	3%	93%
Manganese	1	38,605	2,719	2,719	NA	2%	96%
Total All Pollutants	139	5,677,567	116,925				

Source: EPA, *TRI Releases 2000*.

Table 5-49. Pulp and Paper Phase II PCS Pollutant Discharges Reported for PCS for 2000

Pollutant	Number of Facilities Reporting	PCS Total (lbs/yr)	PCS TWPE/yr	Median TWPE/yr	Range of Facility TWPE/yr	Percentage of Total Phase II TWPE	Cumulative Percentage of Total Phase II TWPE
Chlorine, Total Residual ¹	16	48,134	23,440	121	1 to 10,741	35%	35%
Aluminum, Total (As Al)	10	267,639	17,260	300	11 to 9,989	25%	60%
Aluminum, Total Recoverable	7	95,760	6,175	876	23 to 2,682	9%	69%
Arsenic, Total Recoverable	2	1,522	5,280	2,640	2 to 5,278	8%	77%
Lead Total Recoverable	4	2,143	4,801	9.5	1 to 4,781	7%	84%
Nitrogen, Ammonia Total (As N)	50	986,219	1,805	14	0.006 to 264	3%	87%
Copper, Total (As Cu)	24	2,747	1,722	49	0.25 to 387	3%	89%
Lead, Total (As Pb)	5	652	1,460	177	50 to 853	2%	91%
PCB-1242 (Arochlor 1242)	1	0	1,355	NA	NA	2%	93%
Zinc, Total (As Zn)	32	19,949	933	11	0.005 to 300	1%	95%
Total All Pollutants	172	690 million	67,796				

Source: EPA, *PCSLoads 2000*.

NA - Not applicable, only one reported value.

¹Total residual chlorine discharges reported to PCS may be daily maximum, calculated load may be overestimated.

Table 5-50. Comparison of Analytes Detected in Treated Wastewater (Final Effluent)

Analyte	Mills with Hypochlorite Bleaching			Mills with TCF Bleaching Only	
	Mill 1	Mill 2	Mill 3	Mill 4	Mill 5
Chloroform (g/ADMT)	1.07	0.252	5.36	0	0
2,4,6-TCP (1653) (g/ADMT)	0	0	0.149	0	0
Dioxin TEQ (ug/ADMT)	0	0	0	0	0
AOX ¹ (kg/ADMT)	0.067	0.0362	0.402	0.0211	0.0121
BOD ₅ (kg/ADMT)	3.52	18.5 ²	1.33	0.156	0.667
COD (kg/ADMT)	7.35	2.87	9.75	2.64	8.02
TSS (kg/ADMT)	2.33	0.642	0.91	0.342	1.83

Source: Five-Deink Mill Summary Report, Revision 2, April 15, 2003. Table 6-3.

ADMT - Air Dried Metric Ton.

¹Adsorbable Organic Halides. A bulk parameter that is measured by EPA Method 1650. This method measures the total mass of halogenated organic matter in water and wastewater. In pulp mill wastewaters, this material is almost exclusively chlorinated organic matter.

²Mill 2 has questioned EPA's measured concentration of BOD₅ in their final effluent.

Polycyclic Aromatic Compounds (PACs)

Table 5-51 lists mills that reported releases of PACs to TRI for reporting year 2000 along with the reported basis of their estimate. No mills reported using monitoring data or measurements as the basis of their estimate. The major operations at these mills are the production of unbleached kraft pulp that is made into paperboard on site. Most mills also repulp waste paperboard without bleaching. Kraft pulp mills often burn waste wood (known as hog fuel), coal, and fuel oil to generate steam used directly in the mill or used to generate electricity. Waste from the boilers includes fly ash and bottom ash.

EPA contacted one of the mills that reported PAC releases to obtain information about its operations and verify PACs discharges (2, 3). The mill contact reported using estimates from the National Council for Air and Stream Improvement (NCASI). They reported that the NCASI document references EPA's compilation of air pollution emission factors, AP 42, 5th Ed, Volume 1 for coal, fuel oil, gas, and wood combustion, lists individual PACs released from each type of fuel combusted, and lists benzo(a) pyrene and benzo(j,k) fluorene as the predominant PACs in combustion ash.

For PACs, the contacted mill used an emission factor to estimate 7.1 pounds of PACs that were released to the water in 2000 due to trace amounts in chemicals used at the site (3). The mill contact reported that the majority of the PACs reported released from this mill are associated with wood ash. According to the mill contact, the ash settles out in the settling basin of the wastewater treatment system and will remain on site when this basin fills with solids and is closed, essentially landfilling 158 pounds in 2000. The mill mistakenly reported PACs in this landfilled ash as released to surface water. They corrected this error with EPA's TRI office, and the corrected mass is reflected in Tables 5-47 and 5-51 of this report.

Table 5-51. Phase II Mills Reporting Releases of PACs for TRI Reporting Year 2000

Mill	Location	Subcategory	Direct Discharge (lb/yr)	Direct Discharge (TWPE/yr)	Basis of Estimate for TRI Releases 2000¹
International Paper	Roanoke Rapids, NC	Unbleached Kraft	10	42,836	O
Stone Container Corp.	Florence, SC	Unbleached Kraft	7.1	30,413	C
Packaging Corp. Of America	Clyattville, GA	Unbleached Kraft	7	29,985	E
Great Southern Paper Co.	Cedar Springs, GA	Unbleached Kraft & Semi-chem.	3	12,851	O
International Paper	Prattville, AL	Unbleached Kraft	18	77,104	E
Packaging Corp. Of America	Counce, TN	Unbleached Kraft	16	68,537	O
Georgia-Pacific Corp.	Monticello, MS	Unbleached Kraft	18	77,104	O
Stone Container Corp.	Missoula, MT	Unbleached Kraft	8	34,268	E
Gaylord Container Corp.	Bogalusa, LA	Unbleached Kraft	14	59,970	E
International Paper Pineville Mill	Pineville, LA	Unbleached Kraft	4	17,134	O
Willamette Inds. Inc. Albany Paper Mill	Albany, OR	Unbleached Kraft	6	25,701	E
Longview Fibre Co.	Longview, WA	Unbleached Kraft	2	8,567	E

¹Mills reported basis of estimate in 2000 TRI as: C - Mass balance calculations; E - Published emission factors; and O - Other approaches (e.g., engineering calculations). No mills reported M - Monitoring data/measurements as the basis of their estimate.

Information from the 2000 TRI database provides no concentrations of PACs measured by chemical analysis in Phase II wastewaters above analytical detection limits. Furthermore, EPA sampling at five phase II mills did not detect any PACs. Therefore, EPA concludes TRI-reported PAC discharges are most likely overestimated.

Dioxins

Dioxins are known to be present in wastewaters generated from bleaching chemically pulped wood with chlorine and chlorine-containing compounds. Dioxins are also generated during a variety of combustion processes, including combustion of wood. Wet scrubbers and water conveyance of wood ash may be sources of dioxins in wastewater.

Table 5-52 lists mills that reported releases of dioxin and dioxin-like compounds to TRI for reporting year 2000, along with the reported basis of their estimate. Only 1 of the 11 mills reporting dioxin releases used monitoring data or measurements as the basis of their estimate. These mills have operations in a variety of subcategories, including producing paper from purchased pulp, groundwood, nonwood fibers (cotton linters and flax), and semi-chemical pulp. Mills that use nonwood fibers and mills that purchase pulp typically do not have wastewood boilers, so are unlikely to have wood ash as a dioxin source. Groundwood and semi-chemical mills may have wastewood boilers.

EPA contacted a mill, described above, that reported both PAC and dioxin releases (2,3). The mill contact reported that they used an emission factor based on combustion of wood to calculate dioxin releases, as the dioxins were presumed to be released with sluiced wood ash. This facility changed the assumption underlying its estimate, assuming instead that the wood ash settles out in the settling basin of the wastewater treatment system and will remain on site when this basin fills with solids and is closed, essentially landfilling the waste. From originally reporting a release to surface water of 0.047 grams, the mill contact changed the estimated release to zero.

Three Phase II mills are required to monitor for dioxins in their NPDES permits. However, none of these mills detected dioxins in their effluent in 2000.

Information from the 2000 TRI database and PCS database provides little evidence that dioxins are present in Phase II mill wastewaters above analytical detection limits. Only 1 of 12 mills that reported wastewater releases of dioxins to TRI reported using monitoring data/measurements as the basis for the reported release. In addition, EPA sampling in 2000 did not detect any dioxin above the minimum detection level.

Table 5-52. Phase II Mills Reporting Releases of Dioxin and Dioxin-Like Compounds to TRI for Reporting Year 2000

Mill	Location	Subcategories ¹	Direct Discharge (g/yr)	Direct Discharge (TWPE/yr)	To POTW (g/yr)	After POTW (g/yr) ²	After POTW (TWPE/yr) ²	Basis of Estimate for TRI Releases 2000 ³
Daishowa America Co. Ltd.	Port Angeles, WA	Groundwood Purchased Pulp	0.68	5297				M
Buckeye Lumberton Inc.	Lumberton, NC	Nonwood	0.227	515				E
Schweitzer Mauduit Intl. Inc.	Lee, MA	Nonwood	0.07	246				O
Schweitzer-Mauduit Intl. Inc.	Ancram, NY	Purchased Pulp	0.02	30				O
Procter & Gamble Paper Prods. Co.	Mehoopany, PA	Purchased Pulp	0.01	42				E
Felix Schoeller Technical Papers Inc.	Pulaski, NY	Purchased Pulp	0.003	13				C
Procter & Gamble Paper Prods. Co.	Jackson, MO	Purchased Pulp	0.004	9				O
Blandin Paper Co.	Grand Rapids, MN	Groundwood, Nondeink, Purchased Pulp			6.36	1.082	1221	not reported
Georgia-Pacific Corp.	Plattsburgh, NY	Nondeink, Purchased Pulp, Semi-chemical			0.31	0.053	93	not reported
Procter & Gamble Paper Prods. Co.	Albany, NY	Purchased Pulp			0.015	0.0027	12	not reported
Smart Papers L.L.C.	Hamilton, OH	Purchased Pulp			0.004	0.0005	2.17	not reported
Procter & Gamble Paper Prods.	Oxnard, CA	Purchased Pulp			0.00075	0.0001	0.18	not reported

Source: EPA, *TRIRelases2000*.¹Purchased pulp - subpart K, fine and lightweight paper from purchased pulp and/or subpart L, tissue, filter, nonwoven and paperboard from purchased pulp.²Mass transferred to POTW, that is ultimately discharged to surface waters. Accounts for POTW removals.³Mills reported basis of estimate in 2000 TRI as: C - Mass balance calculations; E - Published emission factors; and O - Other approaches (e.g., engineering calculations); M - Monitoring data/measurements.

5.4.3.4 Pollution Prevention and Treatment Technology

Table 5-53 lists the treatment technologies used by Phase II pulp, paper, and paperboard mills reporting to TRI in 2000. Because production at individual pulp and paper mills has increased over time, they have added treatment units, in sequence or parallel, to their existing treatment. This may explain why a greater number of biological treatment systems were reported (101) than there are direct discharge facilities (95) reporting to TRI for 2000.

Table 5-53. Wastewater Treatment Operations Reported by Phase II Mills, TRI Reporting Year 2000

Wastewater Treatment Process	Number of Facilities Reporting Use	
	Direct ¹ (95 facilities)	Indirect ¹ (18 facilities)
Adsorption - Other	11	0
Air Flotation	9	2
Biological Treatment	101	7
Chemical Precipitation - Other	5	1
Condenser	1	0
Equalization	4	1
Filtration	2	3
General Oxidation (Including Disinfection) - Chlorination	0	1
General Oxidation (Including Disinfection) - Other	0	1
Mechanical Separation	1	0
Neutralization	14	4
Oil Skimming	2	1
Other Chemical Treatment	0	2
Other Blending	1	0
Other Incineration/ Thermal Treatment	3	0
Other Physical Treatment	6	1
Settling/ Clarification	75	8
Sludge Dewatering (Nonthermal)	24	5
Stripping - Air	3	0
Stripping - Steam	3	0

Source: EPA, *TRIRelases2000* (Section 7A Table).

¹In TRI 2000, of the facilities that provided information on their wastewater treatment operations, 95 facilities reported direct releases, 18 transferred to POTWs, and 2 facilities had both direct releases and transfers to POTWs.

5.4.3.5 Industry Trends

The Census Bureau released preliminary results of the 2002 Economic Census on a subsector basis. The Paper Manufacturing subsector, NAICS code 322, includes establishments that make converted paper products as well as establishments that make pulp and/or paper. Thus, NAICS code 322 includes more than just the pulp, paper, and paperboard industry. Never the less, trends shown in Table 5-54 are expected to be the same as for the pulp, paper, and paperboard industry. Sales were flat over the five-year period while the number of establishments declined and employment dropped by more than 15 percent.

Table 5-54. Trends in U.S. Papermaking Industry (Pulp, Paper, and Converted Products)

	1997	2002
Establishments	5,868	5,463
Sales	\$150 billion	\$151 billion
Paid Employees	574 thousand	476 thousand

Source: 2002 Economic Census, <http://www.census.gov/econ/census02/advance/TABLE2.HTM>.

5.4.3.6 Stakeholder and Regional EPA Issues

During previous outreach efforts, some stakeholders raised concerns about discharge of dyes and dioxin from bleaching at secondary fiber mills. During the current outreach cycle, some stakeholders supported the Phase II rule, due to concerns for the number of pollutants discharged by the chemical, mechanical, and secondary fiber de-inking subcategories.

Stakeholders did not provide any data (e.g., estimates of discharge loads, or instances of water quality violations resulting from Phase II mill discharges) supporting their concerns. Nor did EPA's review of available data describing Phase II mill discharges support stakeholders' concerns.

5.4.3.7 Conclusions

In the screening-level analysis of TRI data, the major identified toxic pollutant problem associated with phase II mills was discharges of PACs. No mills reported using monitoring data or measurements as the basis of their estimate of PACs released to surface waters. In a sampling program conducted by EPA at five Phase II mills (all secondary fiber mills), priority pollutant PACs were never detected. In none of the data reviewed by EPA were PACs detected in Phase II wastewaters.

A second pollutant driving the TWPE estimate in the screening-level analysis of TRI data was dioxins. Only one mill reported using monitoring data or measurements as the basis of its estimates of dioxin discharges. The three mills required by NPDES permits to monitor their effluent for dioxins did not detect them in 2000. Also, in a sampling program

conducted by EPA at five Phase II mills (all secondary fiber mills, including three mills that bleached with chlorine-containing compounds), dioxins and furans were not detected above the method minimum level in treated effluent. Thus, the data reviewed by EPA for this report do not identify that dioxins are present in Phase II mill wastewaters.

If PAC and dioxin releases are not included in the estimate of the Phase II TWPE, Phase II toxic pollutant discharges estimated using TRI release information for reporting year 2000 are reduced from 608,875 TWPE to 116,925 TWPE, attributable mainly to manganese, chlorine, and potassium dimethyldithiocarbamate. Detectable levels of PACs and dioxins were not found in data-reported to PCS; therefore, changes to the assumptions about PACs and dioxins have no impact on the Phase II PCS loads (67,800 TWPE), which are attributable mainly to chlorine and aluminum.

5.4.3.8 References

1. Eastern Research Group, Inc. *Five-Deink-Mill Study Summary Report, Revision 2*. Prepared for U.S. EPA Office of Research and Development and Office of Water. April 15, 2003.
2. Heately, Bill. Personal communication from Corporate Environmental Director, Smurfitt Stone Container Corporation, to A. Hooshangi, ERG. February 3, 2004.
3. Heately, Bill. E-mail message from Corporate Environmental Director, Smurfitt Stone Container Corporation, to B. Bicknell, ERG. February 4, 2004.
4. Paperloop Publications, 2001. *Lockwood-Post's Directory of the Pulp, Paper and Allied Trades, 2002*. San Francisco, Paperloop Publications.
5. U.S. EPA. *Development Document for Proposed Effluent Limitations Guidelines and Standards for the Pulp, Paper, and Paperboard Point Source Category*. EPA-821-R-93-019. Washington, D.C. October 1993.

5.4.4 **Steam Electric**

5.4.4.1 Industry Description

The steam electric industry includes electric utilities that combust coal, natural gas, and/or oil to generate electricity for distribution in commerce. Steam electric operations are classified in the following SIC codes:

- SIC code 4911 Electrical Services: Establishments engaged in the generation, transmission and/or distribution of electric energy for sale; and

- SIC code 4931 Electric and Other Services Combined: Establishments primarily engaged in providing electric services in combination with other services, with electric services as the major part though less than 95 percent of the total.

This summary does not include nonutility steam electric power plants located in industrial, commercial, or other facilities. These cogenerators exist as ancillary processes at chemical, pulp and paper, petroleum refining, or other industrial plants. Any pollutant loads associated with these operations are currently considered as part of the primary industry operation.

Information on the number of facilities in the Steam Electric Point Source Category was obtained from three sources: the 1997 U.S. Economic Census, *TRI Releases 2000*, and *PCS Loads 2000*. TRI includes all facilities reporting discharges to any media. In contrast, the PCS includes only facilities that are permitted for discharge to surface waters. Table 5-55 lists the number of steam electric facilities from these sources. The number of facilities under SIC code 4911 reporting to TRI for 2000 represents only about 10 percent of the steam electric industry based on the total number of facilities in the census, while the number of SIC code 4911 facilities reporting discharges to PCS for 2000 represent about 13 percent of the total industry. Of the facilities reporting to TRI, only 48 percent report water discharges.

Table 5-55. Number of Steam Electric Facilities

SIC Code	1997 Census	2000 PCS			2000 TRI				
		Total	Major Dischargers	Minor Dischargers	Total	No Reported Discharge	Direct Dischargers	Indirect Dischargers	Both Direct and Indirect Dischargers
4911	6,212	835	541	294	638	296	321	9	12
4931	NA	53	9	44	43	29	10	2	2
Total		888	550	338	681	325	331	11	14

NA - Data were not presented for SIC code 4931 in the 1997 Economic Census. Data in the Census for SIC code 493 (which includes SIC codes 4931, 4932, and 4939) included 1,989 facilities.

Steam electric facilities are dispersed throughout the United States, with a higher concentration located on the east coast.

5.4.4.2 Regulatory Background

ELGS for the Steam Electric Point Source Category (40 CFR Part 423) are described below.

- EPA first proposed ELGS in October 1974 based on BPT, BAT, NSPS, and PSNS.

- The Agency promulgated final versions of the ELGS in June 1975.
- The proposed 1974 regulations applied to thermal and chemical pollution. In 1976, the thermal regulations were remanded and are now covered under section 316(a) of the Clean Water Act. The chemical pollution limitations affected the following wastestreams:
 - Once-through cooling water,
 - Cooling tower blowdown,
 - Bottom ash transport water,
 - Fly ash transport water,
 - Boiler blowdown,
 - Metal cleaning wastes, and
 - Material storage and construction runoff (including coal pile runoff).
- In 1976, the U.S. Court of Appeals remanded to EPA for reconsideration:
 - NSPS limitations for fly ash transport water,
 - Rainfall runoff limitations for material storage and construction runoff, and
 - BPT clause concerning receiving water characteristics.
- EPA promulgated PSES in 1977, which covered copper in metal cleaning wastes, polychlorinated biphenyls (PCBs), and oil and grease.
- EPA promulgated a second rule in 1982 that:
 - Included the 1974 and 1977 limitations,
 - Revised BAT, NSPS, PSES, and PSNS, and
 - Established separate limitations for each type of wastestream.

The current ELGS, summarized in Table 5-56, are codified at 40 CFR Part 423. EPA promulgated the following additional rules under section 316(b) of the Clean Water Act based on BTA for cooling water intake structures:

- Rules for new sources discharging over 2 MGD (2001); and
- Rules for existing sources discharging over 50 MGD (February 2004).

Table 5-56. Steam Electric Pollutants Regulated by ELGS

Waste Stream	BPT	BAT	NSPS	PSES & PSNS
All Wastestreams	pH: 6-9 PCBs: Zero Discharge	PCBs: Zero Discharge	pH: 6-9 PCBs: Zero Discharge	PCBs: Zero Discharge
Low Volume Wastes	TSS: 100/30 Oil and Grease: 20/15	No Limitation	Equal to BPT	No Limitation
Fly Ash Handling	TSS: 100/30 Oil and Grease: 20/15	No Limitation	Zero Discharge	Zero Discharge (PSNS only) No limitation in PSES
Bottom Ash Handling	TSS: 100/30 Oil and Grease: 20/15	No Limitation	TSS: 100/30 Oil and Grease: 20/15	No Limitation
Chemical Metal Cleaning	TSS: 100/30 Oil and Grease: 20/15 Cu: 1.0/1.0 Fe: 1.0/1.0	Cu: 1.0/1.0 Fe: 1.0/1.0	TSS: 100/30 Oil and Grease: 20/15 Cu: 1.0/1.0 Fe: 1.0/1.0	Cu: 1.0 max
Non-Chemical Metal Cleaning	No Limitation	Reserved	Reserved	Reserved
Once-Through Cooling	FAC: 0.5/0.2 (2 hrs/day)	TRC: 0.20 (2 hrs/day) or = BPT if <25 MW	TRC: 0.20 (2 hrs/day) or = BPT if <25 MW	No Limitation
Cooling Tower Blowdown	FAC: 0.5/0.2 (2 hrs/day)	FAC: 0.5/0.2 (2 hrs/day) 126 Pr. Pol.: No Detect Cr: 0.2/0.2 Zn: 1.0/1.0	FAC: 0.5/0.2 (2 hrs/day) 126 Pr. Pol.: No Detect Cr: 0.2/0.2 Zn: 1.0/1.0	126 Pr. Pol.: No Detect Cr: 0.2 max Zn: 1.0 max
Coal Pile Runoff	TSS: 50 max	No Limitation	TSS: 50 max	No Limitation

Source: *Code of Federal Regulations* <<http://www.epa.gov/epahome/cfr40.htm>>.

Notes:

- Concentrations are in mg/l. If maximum and average concentrations apply, they are given as “maximum/average.” TRC is Total Residual Chlorine, and equals Free Available Chlorine (FAC) plus Combined Residual Chlorine (CRC).

- BCT is reserved for all wastestreams.

- Low Volume Wastes include: clarifier blowdown, makeup water filter backwash, lime softener blowdown, ion exchange softener regeneration, demineralizer regeneration, powdered resin demineralizer back flush, reverse osmosis brine, boiler blowdown, evaporator blowdown, laboratory drains, sanitary wastes, diesel engine cooling system discharge.

5.4.4.3 Wastewater Characteristics and Pollutant Sources

This subsection presents wastewater sources and characteristics as determined from TRI and PCS data. This section also compares pollutant releases reported to TRI and PCS for 2000 with pollutant releases reported in the 1996 PDS (1).

Wastewater Sources

The steam electric power industry is the single largest industrial user of water in the United States. Most of the water used in the steam electric industry is cooling water. Water is heated to high temperatures to create high-temperature and high-pressure steam, which turns the turbines. A generator converts the turbine's mechanical energy into electrical energy. To maintain high pressure in the process, low-pressure steam leaving the turbines must be cooled in condensing tubes, which are kept cool with the constant flow of cooling water.

Types of wastewater discharged by steam electric facilities include cooling water, ash-handling wastes, coal pile drainage, water treatment wastes, boiler blowdown, wet air pollution control device wastes, maintenance cleaning wastes, and miscellaneous waste streams. Table 5-57 lists the typical pollutants from various wastewater streams in steam electric facilities.

Table 5-57. Sources of Process Wastewater in Steam Electric Facilities

Process	Wastewater Pollutants
Cooling Water	Chlorine, iron, copper, nickel, chlorinated organic compounds, temperature, suspended solids
Ash Handling	<i>Generally:</i> SiO ₂ , Al ₂ O ₃ , Fe ₃ O ₃ , CaO, MgO, TiO ₂ , SO ₃ , P ₂ O ₃ , and carbon residuals <i>Possibly:</i> TDS, TSS, sulfate, calcium, chloride, magnesium, nitrate, turbidity, antimony, arsenic, cadmium, chromium, copper, cyanide, iron, lead, mercury, nickel, selenium, silver, thallium, vanadium, and zinc
Coal Pile Runoff	<i>Generally:</i> Acidity, COD, calcium, magnesium, iron, aluminum, manganese, silica, chloride, sulfate, TDS, TSS, arsenic, chromium, copper, nickel, vanadium, and zinc <i>Possibly:</i> Antimony, cadmium, beryllium, lead, selenium, thallium, mercury, and silver
Wastewater Treatment	Clarification: Aluminum sulfate, sodium aluminate, ferrous sulfate, ferrous chloride, and calcium carbonate
	Filtration: Suspended solids
	Ion Exchange: Calcium and magnesium salts, iron, copper, zinc, aluminum, manganese, potassium, soluble sodium, chlorides, sulfates, organics, sulfuric acid, and sodium hydroxide
	Evaporation: Salts (type depends on intake water characteristics)
	Softening: Calcium carbonate, magnesium hydroxide, and sodium salts

Table 5-57 (Continued)

Process	Wastewater Pollutants
Boiler Blowdown	Chlorides, sulfates, precipitated solids containing calcium and magnesium salts, soluble and insoluble corrosion products, and chemical additives
Wet Air Pollution Control Device Waste	<i>Generally:</i> No wastewater is produced <i>Possibly:</i> Sodium and magnesium chlorides, calcium sulfates and sulfide, and trace metals
Maintenance Cleaning	Oil, grease, phosphates, nitrites, suspended solids, dissolved solids, iron, nickel, chromium, vanadium, zinc, magnesium salts, polynuclear hydrocarbons, acidity, alkalinity, and oil
Miscellaneous Wastestreams	Suspended solids, dissolved solids, oil and grease, phosphates, surfactants, acidity, methylene chloride, phthalates, BOD, COD, fecal coliform, and nitrates

Source: Preliminary Study of the Steam Electric Point Source Category, 1996.

Most major facilities reporting to PCS report discharge outfall flow rates. Table 5-58 presents the total annual flow (in millions of gallons) for 2000, median annual discharge flow, and the range of annual flows for steam electric facilities. Facilities not reporting a flow were not included in the median calculation. Data presented in Table 5-58 are based on major dischargers reporting to PCS for 2000.

Table 5-58. 2000 Wastewater Flows for Steam Electric Facilities

SIC Code	Number of Major Facilities Reporting Nonzero Flows	Median Facility Flow in 2000 (MGY)	Range of Facility Flows in 2000 (MGY)	Total Flow in 2000 (MGY)
4911	497	58,661	0.09 - 1,351,273	54,354,346
4931	8	44,390	32 - 360,921	745,410

Source: EPA, PCSLoads2000.

Wastewater Pollutants

Table 5-59 lists the pollutants reported to TRI as discharged directly or indirectly, which account for 95 percent of the total TWPE for steam electric facilities that reported to TRI for 2000. This table presents the number of facilities that reported each chemical, total pounds of chemical discharged, and total TWPE for each chemical. The 2000 TRI database does not include all steam electric facilities or TRI-listed chemicals that are used or produced at levels below reporting thresholds.

Table 5-60 lists the pollutants reported to PCS, which account for 95 percent of the total TWPE for steam electric facilities that reported discharges by major dischargers to PCS for 2000.

Table 5-59. Steam Electric Chemical Releases to Surface Water Reported to TRI for 2000

SIC Code	Pollutant	Number of Facilities Reporting	TRI Total (lbs/yr)	TRI TWPE/yr	Median Facility TWPE/yr	Range of Facility TWPE/yr	Percentage of Total SIC Code TWPE	Cumulative Percentage of Total SIC Code TWPE
SIC 4911- Electrical Services								
4911	Arsenic Compounds	111	156,682	543,582	624	3 - 68,235	29%	29%
4911	Polycyclic Aromatic Compounds (PACs) ^{1a}	4	9,611	475,475	102,805	4,284-265,581	26%	55%
4911	Copper Compounds	191	337,322	211,468	182	1 - 11,284	11%	66%
4911	Vanadium Compounds	83	284,781	177,197	100	1 - 25,947	10%	76%
4911	Mercury Compounds	48	1,251	146,500	293	37 - 55,377	8%	84%
4911	Lead Compounds	90	34,898	78,172	65	2 - 38,806	4%	88%
4911	Selenium Compounds	39	51,944	58,203	583	1 - 8,331	3%	91%
4911	Chromium Compounds	164	109,971	56,290	46	1 - 13,820	3%	94%
4911	Manganese Compounds	198	521,321	36,718	34	0.1 - 3,451	2%	96%
4911	Totals	342	4,193,725	1,854,204				
SIC 4931- Electric and Other Services Combined								
4931	Chlorine	4	1,999	973	6	2-959	40	40
4931	Thallium	1	540	541	NA	NA	22	62
4931	Mercury Compounds	2	2	234	117	117-117	10	72
4931	Copper Compounds	2	260	163	82	3-160	7	78
4931	Manganese	1	1200	85	NA		3	82
4931	Vanadium Compounds	2	135	84	42	19-65	3	85
4931	Vanadium	1	130	81	NA	NA	3	89
4931	Arsenic	1	21	73	NA	NA	3	91
4931	Copper	1	110	69	NA	NA	3	94
4931	Chromium Compounds	2	112	58	29	1-56	2	97
4931	Total	14	15,895	2,441				

Source: EPA, *TRIReleases2000*.

NA - Not applicable. Only one facility reported discharge of chemical.

¹The TWF for benzo(a)pyrene was used as a representative TWF for the PACs category to calculate TWPE.

Table 5-60. Pollutant Discharges Reported by Major Steam Electric Facilities to PCS for 2000

SIC Code	Pollutant	Number of Facilities Reporting	PCS Total (lbs/yr)	PCS TWPE/yr	Median Facility TWPE/yr	Range of Facility TWPE/yr	Percentage of Total SIC Code TWPE	Cumulative Percentage of Total SIC Code TWPE
SIC 4911- Electrical Services								
4911	Copper, Total (as CU)	112	1,181,324	740,574	41	0.1-188,359	26%	26%
4911	Boron, Total (as B)	23	2,265,554	401,491	3,628	41-232,358	14%	39%
4911	Arsenic, Total (as As)	28	106,098	368,090	1,398	5-230,012	13%	52%
4911	Chlorine, Total Residual	173	526,841	256,562	154	0.02- 34,034	9%	61%
4911	Lead, Total (as Pb)	23	101,823	228,083	81	1-174,004	8%	69%
4911	Mercury, Total (as Hg)	6	1,821	213,179	94	4-211,218	7%	76%
4911	Arsenic, Total Recoverable	17	29,559	102,550	482	1- 56,943	4%	80%
4911	Nitrogen, Nitrate Total (as NO ₃)	5	1,549,432,967	96,065	8	0.0002- 96,036	3%	83%
4911	Copper, Total Recoverable	48	122,593	76,854	95	0.03-37,101	3%	86%
4911	Aluminum, Total (as Al)	26	954,636	61,563	118	0.03-26,315	2%	88%
4911	Silver, Total (as Ag)	6	3,336	54,946	806	16-27,446	2%	90%
4911	Iron, Total (as Fe)	136	6,914,403	38,721	2	0.002- 18,655	1%	91%
4911	Zinc, Total (as Zn)	75	770,111	36,001	13	0.02-7,212	1%	92%
4911	Fluoride, Total (as F)	7	693,893	24,286	513	0.1-12,524	1%	93%
4911	Boron, Total Recoverable	1	129,904	23,021	23,021	NA	1%	94%
4911	Selenium, Total (as Se)	33	18,961	21,246	159	0.04-5,378	1%	95%
4911	Totals	541	13,646,371,340	2,857,536				
SIC 4931- Electric and Other Services Combined								
4931	Copper, Total (as Cu)	2	75,077	47,066	23,533	2-47,064	62%	62%
4931	Chlorine, Total Residual	2	45,185	22,004	11,002	9,560- 12,444	29%	91%
4931	Arsenic, Total Recoverable	1	724	2,512	2,512	2,512	3%	95%
4931	Selenium, Total Recoverable	2	1,869	2,094	1,047	675-1,419	3%	97%
4931	Total	9	3,152,453	75,673				

Source: EPA, PCSLoads2000.

As shown in Table 5-59, the pollutants reported to TRI that account for the majority of the total TWPE are arsenic, PACs, copper, vanadium, mercury, lead, selenium, chromium, and manganese. All of these pollutants are likely from coal pile runoff and ash-handling wastes. Coal pile runoff occurs when stored coal is exposed to rainfall and impurities in the coal are rinsed off in the stormwater. Ash is a product of coal or oil combustion and is generally collected in ponds where the ash settles and the water is reused or treated; the ash pond overflow is the ash-handling wastewater. Copper may also be present in cooling water because of cooling equipment corrosion. Copper and other metals may also be present in treated metal cleaning wastes.

As shown in Table 5-60, the pollutants reported to PCS that account for the majority of the total TWPE are mainly metals, including copper, boron, arsenic, lead, aluminum, silver, iron, zinc, and selenium. Chlorine, nitrogen, and fluoride also account for a high TWPE in the industry. The metals and nitrogen are likely from coal pile runoff and ash handling. Chlorine is used in the steam electric industry mainly to control the growth of microorganisms in cooling water systems. Fluoride air pollution is a by-product of coal combustion, and the fluoride present in the water is likely from wet air pollution control devices.

Tables 5-59 and 5-60 also demonstrate that facilities in SIC code 4911 discharge the vast majority of pollutants contributing to the TWPE from this industry, where as SIC code 4931 accounts for less than 0.1 percent of the TWPE discharges from this industry reported to TRI and less than 3 percent of the TWPE discharges reported to PCS.

EPA originally estimated chlorine loads for the industry using PCS data. During subsequent review of the calculation, EPA identified several unique characteristics of the way chlorine is reported to PCS for this industry that contributed to an overestimation of chlorine loads. These characteristics include:

- Chlorine concentration and/or loads may only be reported as maximum values.
- Some facilities report both TRC and FAC, and both values were included in the calculation³.
- PCS may report pollutant concentrations as either a daily maximum or average or as a 2-hour maximum or average. When the concentration is reported as a daily value, EPA calculated annual loads assuming 24 hours of discharge. However, the steam electric regulation (40 CFR Part 423) states that chlorine may only be discharged for 2 hours a day. EPA contacted steam electric facilities in each region and confirmed that chlorine discharge occurs for only 2 hours a day. Therefore, chlorine

³ Free Available Chlorine (FAC) is a subset of Total Residual Chlorine (TRC).

loads based on 24 hours of discharge were overestimated by a factor of twelve.

EPA adjusted the PCS loads to correct for facilities reporting only maximum chlorine discharge, eliminate double counting of different types of chlorine, and correct the time period of the discharge. Before the adjustments, the PCS chlorine loads were 8,907,981 pounds per year (4,338,035 TWPE). After adjustments, the PCS chlorine loads were 526,841 pounds per year (256,562 TWPE).

The 1996 PDS estimated parameter loadings from NPDES monitoring data, which were extracted from PCS reports for 1992. A total of 512 major facilities reported to PCS under SIC codes 4911 and 4931 in 1992. However, data were included in *PCSLoads2000* for only 361 facilities due to missing or erroneous data. In comparison, the PCS data for 2000 includes pollutant loads for 550 major dischargers. The 1996 PDS made the following conclusions about the 1992 PCS monitoring data:

1. Chlorine and iron constitute the greatest overall loads in pounds;
2. Chlorine represents the greatest overall load in TWPEs; and
3. Mercury and arsenic were the greatest contributors of priority pollutant TWPEs.

Table 5-61 shows the highest parameter loadings (as measured by TWPE) reported to PCS in 1994, compared to the reported 2000 discharges.

Table 5-61. Five Highest Parameter Loadings (as Measured by TWPE) Reported to PCS in 1992 and 2000

Parameter	1992 PCS Data (361 facilities)		2000 PCS Data (550 facilities)	
	# Facilities	Pounds Released	# Facilities	Pounds Released
Chlorine	218	7,710,000 ¹	203	497,503
Polychlorinated Biphenyls, PCBs	1	35	0	NA
Mercury	18	652	6	1,821
Boron	15	1,330,000	23	2,265,555
Arsenic	54	32,600	28	106,098

Source: EPA, Preliminary Study of the Steam Electric Point Source Category, 1996 and *PCSLoads2000*.

¹Chlorine pounds may represent a maximum due to calculation from reported daily maximum concentrations.

The PDS did not adjust chlorine loads to address the unique reporting issues associated with chlorine. Before EPA adjusted the 2000 PCS data, the 1992 and 2000 estimated chlorine loads were similar. However, because the chlorine releases reported in 2000 in Table

5-61 were adjusted, they might not be comparable to 1992 PCS data. PCBs were also identified as a top pollutant using 1992 PCS data. However, only one facility reported a PCB discharge. Mercury, boron, and arsenic were reported as top pollutants in both 1992 and 2000.

The following is a summary of the comparison of the 1996 PDS and the 2000 TRI and PCS data used for this review:

- The total number of major dischargers reporting to PCS and having estimated annual loads increased from 361 to 550;
- PCS releases:
 - Chlorine and iron constituted the greatest overall loads in pounds in 1992; nitrate nitrogen and iron constituted the greatest overall loads in pounds in 2000.
 - Chlorine, mercury, boron, and arsenic were the pollutants discharged by more than one facility that contributed the bulk of the TWPE estimate in 1992.
 - Copper, boron, arsenic, chlorine, lead and mercury contributed the bulk of the TWPE estimate in 2000.
 - Chlorine contributed the most to the pollutant load in 1992, but not in 2000 due to adjustments made to the load calculation.

Other Wastewater Pollution Issues

Some steam electric facilities use bromine in place of chlorine to prevent the growth of microorganisms in condenser tubes. Bromine is not explicitly regulated under 40 CFR Part 423, although total residual oxidants (TRO) or free available oxidants (FAO) may be limited by facilities' NPDES permits. The 1996 PDS presented information from a survey of regional contacts to determine the extent of bromine use. The survey showed that bromine usage was increasing, and the limits for bromine are generally based on chlorine. Of the 550 facilities with load estimation based on 2000 PCS data, 89 facilities (16 percent) reported TRO or FAO.

5.4.4.4 Pollutant Prevention and Treatment Technology

Most direct discharge facilities reporting to TRI use settling/clarification. Table 5-62 lists the treatment technologies most commonly used by steam electric facilities reporting to TRI for 2000.

Table 5-62. Wastewater Treatment Operations Reported By Steam Electric Facilities, TRI Reporting Year 2000

Wastewater Treatment Process	Number of Facilities Reporting Use	
	Direct Dischargers (235 facilities)	Indirect Dischargers (11 facilities)
Settling/Clarification	222	9
Neutralization	112	6
Oil Skimming	53	0
Chemical Precipitation - Lime or Sodium Hydroxide	42	2
Equalization	40	1
Sludge Dewatering (Nonthermal)	25	3
Chemical Precipitation - Other	23	3
Filtration	23	1
Aerobic Biological Treatment	12	0
Other Chemical Treatment	12	0

Source: EPA, Section 7A Table of the TRI 2000 Database.

As new wastewater treatment technologies become affordable and available, they have been used in the steam electric industry. One of the most commonly used in the industry is membrane filtration, especially reverse osmosis. Along with membrane filtration, ultrafiltration and microfiltration have been used to pretreat the water entering the reverse osmosis membranes. The industry is also using electrodeionization (EDI). EDI combines ion exchange membranes and ion exchange resins to produce boiler feed water with treatment that minimizes the use of chemical additives. Additionally, the industry is using ozone and ultraviolet light to replace chlorine as a disinfectant. (3)

5.4.4.5 Industry Trends

The steam electric industry was last studied by EPA in 1996 for ELGS (1). Table 5-63 compares the industry statistics presented in the 1996 PDS with data collected by the Energy Information Administration (EIA) for 2000. Total electricity production has increased by about 30 percent. The percentage of total electricity generated by nonutilities has increased from 11 percent to 21 percent.

Table 5-63. Comparison of Industry Statistics

	1996 PDS	2000 Review
Operable Capacity, megawatts	699,971	811,625
Total Electricity Production, million megawatthours	2,883	3,800
Electricity Production by Utilities, million megawatthours	2,558 (89 percent of total)	3,015 (79 percent of total)
Electricity Production by Nonutilities, million megawatthours	325 (11 percent of total)	785 (21 percent of total)
Number of Major Facilities With Loads Calculated from PCS	361	541

Source: Preliminary Study of the Steam Electric Point Source Category, 1996; U.S. Economic Census, 1997; EPA, *PCSLoads2000*; EIA 2000 (2).

5.4.4.6 Stakeholder and Regional EPA Issues

Stakeholder and EPA Regional issues identified during ELGS review are summarized below. Commenters noted:

- Applicability concerns for cogeneration units;
- Potential for toxic pollutants in coal pile runoff (including mercury and selenium);
- The growing use of POTW effluent as cooling water; and
- The need to expand the scope of the regulations due to exempt facilities that should not be exempt and many newer facilities that are not covered.

EPA met with representatives from the Utility Water Act Group (UWAG). Concerns expressed by UWAG include:

- Using half the detection limit for values below the detection limit when pollutant concentrations are reported at all during the year might overestimate metal loads;
- The failure to adjust for intake pollutants unfairly disadvantages the steam electric industry;
- EPA should exclude pollutants not representative of the loads discharged by steam electric facilities from the pollutant data; and
- The toxic-weighting factor for chlorine is inappropriate.

5.4.4.7 Conclusions

In the screening-level analysis of TRI data, EPA identified the major toxic pollutants associated with steam electric power plants as metals (including arsenic, copper and others) and PACs. These pollutants likely come from coal pile runoff and ash-handling wastes. With the exception of copper and iron in chemical metal cleaning, the steam electric ELGS do not contain limits for most metals or PACs.

In the review of PCS data, EPA identified the major pollutants of concern as metals (copper, boron, arsenic, and others) and chlorine. The metals are likely from coal pile runoff and ash handling, while chlorine is used as a biocide in cooling water systems.

Coal pile runoff has effluent limitations only for TSS. The ash-handling wastestream has limits for oil and grease and TSS. Neither wastestream has limits for metals or PACs, though coal pile runoff and ash handling may be sources of toxic metals and PACs.

The once-through cooling and the cooling tower blowdown wastestreams have limits for chlorine. However, there are available substitutes for chlorine that are not controlled by 40 CFR Part 423. Bromine is an effective biocide that is being used in the industry. Some permits may limit bromine based on the chlorine limits, although bromine is more toxic than chlorine in freshwater.

EPA still lacks information about the steam electric industry. EPA does not know the following:

- The source of metals in reported discharge;
- The concentrations of pollutants discharged and present in in-process wastestreams;
- The available control technologies for metals and PACs;
- Alternatives to chlorine-containing biocides, including their toxicity, cost, and other environmental impacts;
- The impact of nondetects being estimated to be equal to half the detection limit; and
- How electricity production wastewater streams are controlled at cogeneration operations.

Because this industry ranks high relative to other industries in terms of TWPE and because EPA continues to have data gaps and issue that remain unresolved, EPA will continue to study of the steam electric industry during the next review cycle.

5.4.4.8 References

1. U.S. EPA. *Preliminary Study of the Steam Electric Point Source Category*. Washington, D.C. 1996.
2. Energy Information Administration. *Electric Power Annual 2000*. U.S. Department of Energy. DOE/EIA-0348(2000)/1. Washington, D.C. 2001. Available online at: <http://tonto.eia.doe.gov/FTPROOT/electricity/0348001.pdf>.
3. *Industrial WaterWorld*. "Growth Projected for Power Plant Water Treatment Technologies Market." January 2004. Available online at: http://www.pennnet.com/Articles/Article_Display.cfm?Section=Articles&ARTICLE_ID=199184&VERSION_NUM=1&pc=ENL.

5.4.5 **Textile Mills**

5.4.5.1 Industry Description

The textile industry includes facilities that manufacture and process textile materials, such as carpets, broad woven fabrics, and knitwear. These facilities are classified under SIC major group 22, Textile Mill Products, which includes facilities using wet processes, such as scouring, dyeing, finishing, printing, and coating, discharge contact wastewater. EPA divided the Textile Mills Point Source Category into nine subcategories based on the wet processing segment of the industry. Table 5-64 lists the regulated subcategories as well as their associated SIC codes.

Table 5-64. Textile Mills Subcategories

Subpart	Name	Applicable SIC Code(s)
A	Wool Scouring ¹	2299
B	Wool Finishing ¹	2231
C	Low Water Use Processing	2211, 2221, 2231, 2241, 2253, 2254, 2259, 2273, 2281, 2282, 2284, 2295, 2296, 2298
D	Woven Fabrics Finishing ¹	2261, 2262
E	Knit Fabric Finishing ¹	2251, 2252, 2257, 2258
F	Carpet Finishing ¹	2273
G	Stock & Yarn Finishing ¹	2269
H	Nonwoven Manufacturing	2297
I	Felted Fabric Processing	2299

Source: Preliminary Study of the Textile Mills Point Source Category, 1996.

¹Subcategories with wet processing.

EPA obtained information on the number of facilities in the Textile Mills category from three sources: the 1997 U.S. Economic Census, the *TRIRelases2000*, and *PCSLoads2000*. The 2000 TRI database includes all facilities reporting discharges to any media. The 2000 PCS database includes facilities that are permitted for discharge to surface waters. Table 5-65 lists the number of textile mills by SIC code from these sources. The number of facilities reporting to TRI for 2000 represents only about 5 percent of the textile industry based on the total number of textile mills in the census, while the number of facilities reporting discharges to PCS for 2000 represents less than 2 percent of the total industry.

Table 5-66 presents the number and percentage of the textile mills in *TRIRelases2000*.

Textile mills are predominantly located on the east coast, with concentrations in North Carolina and South Carolina.

Table 5-65. Number of Textile Mills

SIC Code	1997 U.S. Economic Census	2000 TRI-All Dischargers	2000 PCS	
			Major Dischargers	Minors Dischargers
2211 - Broadwoven Mills, Cotton	398	15	12	9
2221 - Broadwoven Mills, Manmade Fiber & Silk	452	28	8	10
2231 - Broadwoven Mills, Wool	78	13	4	2
2241 - Narrow Fabric	273	5	0	2
2251 - Women's Hosiery	137	0	1	0
2252 - Hosiery, NEC	455	3	1	2
2253 - Knit Outerwear	643	4	2	0
2254 - Knit Underwear	54	1	1	0
2257 - Circular Knit Fabric Mills	359	1	3	0
2258 - Lace and Warp Knit	262	4	3	0
2259 - Knitting Mills, NEC	62	3	0	0
2261- Finishers, Broadwoven Cotton	442	13	11	7
2262 - Finishers, Broadwoven Manmade & Silk	306	15	12	2
2269 - Finishers, NEC	155	10	11	2
2273 - Carpets & Rugs	474	17	4	1
2281 - Yarn Spinning	393	5	3	7
2282 - Yarn Texturing	146	1	0	5

Table 5-65 (Continued)

SIC Code	1997 U.S. Economic Census	2000 TRI-All Dischargers	2000 PCS	
			Major Dischargers	Minors Dischargers
2284 - Thread Mills	67	4	2	0
2295 - Coated Fabrics	229	6	0	3
2296 - Tire Cord and Fabrics	21	8	0	0
2297 - Nonwoven Fabrics	193	5	0	3
2298 - Cordage & Twine	201	3	0	1
2299 - Textile Goods, NEC	355	5	1	5
Total	6,155	296 (4.8%)	79 (1.3%)	61 (0.99%)

Source: U.S. Economic Census, 1997; EPA, *TRIRelases2000*; EPA, *PCSLoads2000*.

Table 5-66. Number of Textile Mills by Discharge Type (TRI 2000)

SIC Code	Direct Dischargers Only		Indirect Dischargers Only		Both Direct and Indirect Dischargers		No Reported Wastewater Discharge	
	Number	Percentage of All Facilities in SIC Code	Number	Percentage of All Facilities in SIC Code	Number	Percentage of All Facilities in SIC Code	Number	Percentage of All Facilities in SIC Code
2211	3	20%	4	27%	1	6%	7	47%
2221	0	0%	3	11%	1	4%	24	85%
2231	3	23%	2	15%	0	0%	8	62%
2241	0	0%	0	0%	0	0%	5	100%
2252	0	0%	3	100%	0	0%	0	0%
2253	0	0%	3	75%	1	25%	0	0%
2254	1	100%	0	0%	0	0%	0	0%
2257	0	0%	0	0%	0	0%	1	100%
2258	2	29%	2	29%	0	0%	3	43%
2259	1	25%	2	50%	0	0%	1	25%
2261	1	4%	12	50%	0	0%	11	46%
2262	5	21%	10	42%	0	0%	9	37%
2269	2	9%	8	35%	0	0%	13	56%
2273	1	3%	15	41%	1	3%	20	54%
2281	0	0%	0	0%	0	0%	5	100%
2282	0	0%	1	25%	0	0%	3	75%
2284	0	0%	4	57%	0	0%	3	43%

Table 5-66 (Continued)

SIC Code	Direct Dischargers Only		Indirect Dischargers Only		Both Direct and Indirect Dischargers		No Reported Wastewater Discharge	
	Number	Percentage of All Facilities in SIC Code	Number	Percentage of All Facilities in SIC Code	Number	Percentage of All Facilities in SIC Code	Number	Percentage of All Facilities in SIC Code
2295	1	2%	3	6%	2	4%	44	88%
2296	0	0%	6	46%	2	15%	5	38%
2297	1	8%	4	33%	0	0%	7	58%
2298	0	0%	0	0%	0	0%	3	100%
2299	1	8%	4	31%	0	0%	8	62%
Total	22 (7.4%)		86 (29%)		8 (2.7%)		180 (61%)	

Source: EPA, *TRIRelases2000*.

5.4.5.2 Regulatory Background

Under the existing ELGS for the Textile Mills Point Source Category, EPA divided the industry into nine subcategories based on the type of processes used. ELGS found in 40 CFR Part 410 are applicable to process wastewater discharged from operations in the nine subcategories that manufacture textiles. ELGS for the Textile Mills category are described below:

- EPA first proposed ELGS in February 1974 based on BPT, BAT, NSPS, and PSNS.
- EPA first promulgated ELGS in July 1974.
- The U.S. Court of Appeals remanded all regulations except BPT to EPA for reconsideration.
- EPA promulgated a revised rule in 1982 that:
 - Imposed BPT limits on two new subcategories,
 - Revised BAT and NSPS for all subcategories, and
 - Required POTWs to enforce local limits in place of PSNS or PSES (i.e., no pretreatment standards established for new or existing sources).

- Subcategories for this category are presented below.

Subpart	Subcategory
A	Wool Scouring ¹
B	Wool Finishing ¹
C	Low Water Use Processing
D	Woven Fabrics Finishing ¹
E	Knit Fabric Finishing ¹
F	Carpet Finishing ¹
G	Stock & Yarn Finishing ¹
H	Nonwoven Manufacturing
I	Felted Fabric Processing

Source: Preliminary Study of the Textile Mills Point Source Category, 1996.

¹Subcategories with wet processing.

- EPA established the basis for BPT as biological treatment.
- EPA established the basis for BAT for the nine subcategories as follows:
 - Biological treatment (same technology as BPT): Felted Fabric Processing.
 - Biological treatment and filtration: Woven Fabric Finishing; Knot Fabric Finishing; Carpet Finishing; Stock& Yarn Finishing; and Nonwoven Manufacturing.
 - Biological treatment and chemical coagulation and filtration: Wool Scouring; Wool Finishing; and Hosiery Products Subdivision of Knit Fabrics.

The current ELGS, summarized in Table 5-67, are codified at 40 CFR Part 410.

Table 5-67. Pollutants Regulated by Existing Textile Mill ELGS

40 CFR Part	Subcategory	BPT	BAT	NSPS
410.10	Wool Scouring ¹	BOD ₅ , COD, TSS, Oil & Grease, Sulfide, Phenols, Total Chromium, pH	COD, Sulfide, Phenols, Total Chromium	BOD ₅ , COD, TSS, Sulfide, Phenols, Total Chromium, pH
410.20	Wool Finishing ¹	BOD ₅ , COD, TSS, Sulfide, Phenols, Total Chromium, pH	COD, Sulfide, Phenols, Total Chromium	BOD ₅ , COD, TSS, Sulfide, Phenols, Total Chromium, pH
410.30	Low Water Use Processing	BOD ₅ , COD, TSS, pH	COD	BOD ₅ , COD, TSS, pH
410.40	Woven Fabrics Finishing ¹	BOD ₅ , COD, TSS, Sulfide, Phenols, Total Chromium, pH	COD, Sulfide, Phenols, Total Chromium	BOD ₅ , COD, TSS, Sulfide, Phenols, Total Chromium, pH
410.50	Knit Fabric Finishing ¹	BOD ₅ , COD, TSS, Sulfide, Phenols, Total Chromium, pH	COD, Sulfide, Phenols, Total Chromium	BOD ₅ , COD, TSS, Sulfide, Phenols, Total Chromium, pH
410.60	Carpet Finishing ¹	BOD ₅ , COD, TSS, Sulfide, Phenols, Total Chromium, pH	COD, Sulfide, Phenols, Total Chromium	BOD ₅ , COD, TSS, Sulfide, Phenols, Total Chromium, pH
410.70	Stock & Yarn Finishing ¹	BOD ₅ , COD, TSS, Sulfide, Phenols, Total Chromium, pH	COD, Sulfide, Phenols, Total Chromium	BOD ₅ , COD, TSS, Sulfide, Phenols, Total Chromium, pH
410.80	Nonwoven Manufacturing	BOD ₅ , COD, TSS, Sulfide, Phenols, Total Chromium, pH	COD, Sulfide, Phenols, Total Chromium	BOD ₅ , COD, TSS, Sulfide, Phenols, Total Chromium, pH
410.90	Felted Fabric Processing	BOD ₅ , COD, TSS, Sulfide, Phenols, Total Chromium, pH	COD, Sulfide, Phenols, Total Chromium	BOD ₅ , COD, TSS, Sulfide, Phenols, Total Chromium, pH

Source: *Code of Federal Regulations* <<http://www.epa.gov/epahome/cfr40.htm>>.

¹Subcategories with wet processing.

5.4.5.3 Wastewater Characteristics and Pollutant Sources

This subsection presents the wastewater characteristics of PCS reporting facilities and the pollutants contributing the highest load as reported by TRI and PCS facilities. This section also compares pollutant releases reported to TRI and PCS for 2000 with pollutant releases reported in the 1996 Preliminary Study (1). For this 304(m) review, EPA collected very little new information on indirect dischargers and continues to rely on the 1996 Preliminary Study.

Wastewater Characteristics

Most major facilities reporting to PCS also report discharge outfall flow rates. Table 5-68 presents the total annual flow (in millions of gallons) for 2000, median annual discharge flow, and the range of annual flows for each SIC code. Facilities not reporting a flow were not included in the median calculation. Data presented in Table 5-68 are based on major dischargers reporting to PCS for 2000. In some cases, the PCS reported flows may include stormwater discharges and noncontact cooling water, as well as process wastewater.

Table 5-68. 2000 Wastewater Flows for Textile Mills

SIC Code	Number of Major Facilities Reporting Nonzero Flows	Median Facility Discharge 2000 (MGY)	Range of Facility Flows 2000 (MGY)	Total Flow 2000 (MGY)
2211	12	422	9-1,359	5,467
2221	8	114	13-311	1,273
2231 ¹	4	96	39-1,088	1,320
2251 ¹	1	22	NA	22
2252 ¹	1	52	NA	52
2253	2	79	64-95	159
2254	1	796	NA	796
2257 ¹	3	202	7-291	500
2258 ¹	3	286	246-293	825
2261 ¹	11	726	49-1,778	7,814
2262 ¹	10	332	1-5,061	7,697
2269	11	132	7-675	2,950
2273 ¹	4	550	490-672	2,262
2281	3	221	67-330	618
2284	2	206	30-382	413
2299	1	70	NA	70
Total	79			32,238

Source: EPA, *PCSLoads2000*.

¹Wet Process.

NA - Not applicable; only one facility reported a nonzero discharge flow rate.

Finishers of broadwoven cotton, manmade fibers, and silk (SIC codes 2261 and 2262) had the largest total wastewater flows. Of the 10 facilities reporting wastewater flows in SIC code 2262, one facility's reported flow accounts for 66 percent of the total wastewater flow. The total annual wastewater flow is more equally distributed among the 11 facilities reporting in

SIC code 2261, and no facility's reported flow accounts for more than 23 percent of the total wastewater flow.

Table 5-69 lists the pollutants reported to TRI as discharged directly or indirectly, which account for 95 percent of the total TWPE for textile mills that reported to TRI for 2000. This table presents the number of facilities that reported each chemical, total pounds of chemical discharged for SIC code 22, and total TWPE for each chemical.

Table 5-70 lists the pollutants reported to PCS, which account for 95 percent of the total TWPE for textile mills that reported discharges to PCS for 2000.

As shown in Tables 5-69 and 5-70, the pollutants reported to TRI and PCS that account for the majority of the total TWPE are sulfide and chlorine. In TRI, over 97 percent of the TWPE results from indirect dischargers. In some dyeing processes, sulfur dyes are reacted with sodium sulfide to make the sulfur dye water soluble. This operation is the source of sulfide in textile mill effluent. Sulfide is regulated by BPT and BAT limitations in every wet processing subcategory. Thirty-day average limits on sulfide range from 0.04 to 0.22 kg/kkg of product. Chlorine is used primarily in bleaching processes, and in minor applications, to disinfect treated wastewater and remove color from wastewater (1).

In PCS, the chlorine loads are reported as total residual chlorine (TRC). The TRC discharges may be calculated from reported daily maximum concentration, and thus represent a maximum mass discharge. Other pollutant mass discharges are based on reported monthly averages for either mass or concentration.

EPA conducted a study of the textile mills industry in 1996 to determine if existing ELGS for this industry required updating or revision. Data sources for the 1996 Preliminary Study include the Textiles Blue Book, the U.S. Department of Commerce, POTW surveys, and the TRI and PCS databases. Table 5-71 presents the total annual loads of chlorine and sulfide that were reported in the 1996 Preliminary Study (1). The 1996 study used 1992 TRI data and 1994 PCS data.

The TRI database for 1992 or any reporting year does not include all textile mills or TRI-listed chemicals that are used or produced at levels below reporting thresholds. Furthermore, estimates may be based on monitoring data or on mass balance calculations. The accuracy and comparability of these estimates, therefore, is unknown, as the method of estimation may vary from facility to facility or for the same facility for different time periods.

Table 5-69. Textile Mill Chemical Releases to Surface Water Reported to TRI for 2000

SIC Code	Pollutant	Number of Facilities Reporting ¹		TRI Total (lbs/yr)			TRI TWPE/yr			Median Facility TWPE/yr	Range of Facility TWPE/yr	Percentage of Total SIC Code TWPE	Cumulative Percentage of Total SIC Code TWPE
		Direct	Indirect	Direct	Indirect	Total	Direct	Indirect	Total				
22	Chlorine	5	3	2,681	126,296	128,977	1,306	61,504	62,810	210	2-53,125	74%	74%
22	Sodium Nitrite	0	5	0	43,559	43,559	0	16,262	16,262	890	93-13,355	19%	93%
22	Chromium Compounds	7	6	1,714	1,677	3,391	877	858	1,735	92	1-505	2%	95%

Source: EPA, *TRIRelases2000*.¹A total of 116 facilities reported wastewater releases to TRI for 2000.

Table 5-70. Textile Mill Pollutant Discharges Reported to PCS for 2000

SIC Code	Pollutant	Number of Facilities Reporting ¹	PCS Total (lbs/yr)	PCS TWPE/yr	Median Facility TWPE/yr	Range of Facility TWPE/yr	Percentage of Total SIC Code TWPE	Cumulative Percentage of Total SIC Code TWPE
22	Sulfide, Total (as S)	66	53,067	148,616	885	22-44,274	50%	50%
22	Chlorine	30	223,975	109,072	39	0-78,414	37%	87%
22	Sulfide, Total	3	5,708	15,985	6,443	1,332-8,210	5%	92%
22	Copper, Total (as Cu)	33	19,366	12,140	23	0-10,949	4%	96%

Source: PCSLoads2000.

¹PCS loads contains discharge data for 79 facilities in SIC code 22.**Table 5-71. Textile Mill Pollutant Discharges Reported in 1996 Preliminary Study**

Pollutant	Total Annual Load (lb/yr)			
	1994 PCS ¹	Number of Reporting Facilities	1992 TRI	Number of Reporting Facilities
Chlorine	86,598	10	259,601	21
Sulfide	32,254 to 71,118	10	NR ^b	NR ^b

Source: Preliminary Study of Textile Mills Point Source Category, 1996, Table IX-1, pg. 47.

¹The range of PCS loads represents values that were calculated assuming ND = 0 and ND = ½ DL. Chlorine loads were calculated only assuming ND = 0.

NR - The pollutant was not reported in the data source.

A total of 228 textile mills reported chemical releases to TRI for 1992 compared to the 296 mills that reported for 2000. Table 5-72 presents the highest total annual chemical releases reported to TRI for 1992, compared to the data reported for 2000. The total pounds and the number of facilities reporting releases of these chemicals have significantly decreased from 1992 to 2000. Because many reported releases are based on estimates (not measurements), the decrease in reported releases might be attributed to changes in estimation methodology as well as reduction in actual releases.

Table 5-72. Eight Highest Chemical Releases Reported to TRI in 1992 and 2000

Chemical	1992 TRI Database		2000 TRI Database	
	Number of Facilities	Pounds Released	Number of Facilities	Pounds Released
Ammonium sulfate ¹	38	2,572,379	0	NR
Sulfuric acid ¹	19	1,284,439	1	0
Ammonia	62	978,434	22	77,221
Biphenyl	23	668,528	5	3,660
Ethylene glycol	19	639,457	8	22,383
Chlorine	21	259,601	8	128,977
Chromium compounds	20	125,477	13	3,390
Chromium	1	512	2	231

Source: EP, Preliminary Study of the Textile Mills Point Source Category, 1996 and *TRIRelases2000*.

¹Ammonium sulfate and sulfuric acid were removed from the TRI list and reporting requirements.

NR - The pollutant was not reported to the data source.

The 1996 study estimated parameter loadings from NPDES monitoring data, which were extracted from PCS reports for 1994. A total of 423 records were found under SIC code 22, of which only 59 reported both concentration and flow values needed to estimate loads. For any given pollutant, 10 was the highest number of facilities reporting discharges of that pollutant. In comparison, the PCS data for 2000 include pollutant loads for 79 major dischargers, and up to 69 facilities reported discharges of a single pollutant. The 1996 Preliminary Study made the following conclusions about the 1994 PCS monitoring data:

1. Metal parameters consistently detected at low levels were copper, chromium, and zinc;
2. Ammonia, chlorine, and sulfide were the most frequently monitored inorganic parameters; and
3. Few organic priority pollutants were consistently identified.

Table 5-73 presents the highest parameter loadings reported to PCS in 1994, compared to the reported 2000 discharges.

Table 5-73. Five Highest Parameter Loadings Reported to PCS in 1994 and 2000

Parameter	1994 PCS Data		2000 PCS Data	
	Number of Facilities	Pounds Released	Number of Facilities	Pounds Released
Zinc	10	233,856	28	3,949
Chlorine	10	86,598	30	223,975 ¹
Sulfide	10	71,118	66	53,067
Ammonia	10	48,784	34	120,551
Copper	10	25,228	33	19,366

Source: EPA, Preliminary Study of the Textile Mills Point Source Category, 1996; *PCSLoads2000*.

¹Chlorine pounds may represent a maximum due to calculation from reported daily maximum concentrations.

Chlorine contributes the majority of the TWPE for the textile industry in 2000. Chlorine accounts for 90 percent of the total TWPE in TRI and 30 percent of the total TWPE in PCS in 2000. Chlorine releases from 1994 and 2000 may not be comparable since 2000 chlorine pounds might have been calculated using daily maximum concentrations. However, the 1994 chlorine discharges might be calculated the same way. Sulfide was also identified in PCS as a high contributor to the pollutant loading, accounting for 60 percent of the total TWPE in 2000. According to data in Table 5-73, sulfide releases per facility decreased although the number of reporting facilities increased since 1994. Ammonia is the only pollutant for which reported total industry releases were higher in 2000 than in 1994; however, the per-facility releases decreased more than 15 percent⁴.

The following is a summary of the comparison of the 1996 Preliminary Study and the 2000 TRI and PCS data used for this review:

- The total number of facilities reporting to TRI has increased from 228 to 296;
- The total number of major dischargers with data in PCS has increased from 59 to 79;
- Total releases of the top five pollutants reported to TRI for the industry in 1992 have significantly decreased;
- Total chlorine releases reported to TRI have decreased from 259,601 to 128,977 lb/yr;

⁴Based on the total pounds released and the number of reporting facilities for 2000 and 1994.

- Chlorine releases in the PCS 2000 data are not comparable to 1994 data since the 2000 pounds might have been calculated from reported daily maximum concentrations; and
- Ammonia is the only pollutant for which reported total industry releases were higher in 2000 than in 1994.

Wastewater Pollutant Sources

Types of wastewater discharged by textile mills include cleaning water, process water, noncontact cooling water, and stormwater. Likely sources of textile process wastewater include wet processes such as scouring, dyeing, finishing, printing, and coating of textile products. One of the largest sources of wastewater pollutants is desizing, or the process of removing size chemicals from textiles (1). Typical sizing agents include starch, polyvinyl alcohol, carboxymethyl cellulose, and polyacrylic acid (2).

Dyeing processes are another large source of wastewater. The primary source of wastewater from dyeing operations is spent dyebath and washwater. Wastewater from dyeing operations typically contains residual dye and auxiliary chemicals, as well as cleaning solvents. Dyes are also a major source of metals in textile wastewater. Metals are usually present in low concentrations, and typically include zinc, nickel, chromium, and cobalt.

Finishing processes generally produce wastewater containing natural and synthetic polymers. Chemical handling and high pH are the primary pollution concerns associated with the bleaching process. Table 5-74 lists the typical pollutants generated from various process steps in textile manufacturing.

Table 5-74. Sources of Process Wastewater in Textile Manufacturing

Process	Wastewater
Slashing/Sizing	BOD; COD; metals; cleaning waste, size
Desizing	BOD from water soluble sizes; synthetic size; lubricants; biocides; antistatic compounds
Scouring	Disinfectants and insecticide residues; NaOH; detergents; fats; oils; pectin; wax; knitting lubricants; spin finishes; spent solvents
Bleaching	Hydrogen peroxide, sodium silicate or organic stabilizer; high pH
Mercerizing	High pH; NaOH
Dyeing	Metals; salt; surfactants; toxics; organic processing assistants; cationic materials; color; BOD; COD; sulfide; acidity/alkalinity; spent solvents
Printing	Suspended solids; urea; solvents; color; metals; heat; BOD; foam
Finishing	BOD; COD; suspended solids; toxics; spent solvents

Source: EPA, *Preliminary Study of the Textile Mills Point Source Category*, 1996.

Other Wastewater Pollution Issues

Dyes and pigments released from the printing and dyeing processes are the major sources of color in textile wastestreams. Dyes that are not anchored to fabric are discarded as spent dyebath. Large releases of color can interrupt photosynthesis, which can decrease the levels of dissolved oxygen in receiving streams (2). EPA has not historically regulated color in the ELGS program.

Brominated flame retardants (BFRs) might be released to wastewater during finishing steps of the textile manufacture process. Significant water releases might result from bath dumps from finishing processes, equipment cleaning waste, rinse water from the cleaning of containers that contained the flame retardant chemicals, and area washdowns (3). The five major types of BFRs include:

- Tetrabromobisphenol A;
- Hexabromocyclododecane;
- Decabromodiphenyl ether (DBDE);
- Octabromodiphenyl ether (OBDE); and
- Pentabromodiphenyl ether (PentaBDE).

DBDE is the most commonly used BFR, and accounts for 80 percent of the total polybrominated diphenyl ether production worldwide. BFRs have been detected in the environment in locations far from sites where they are produced or used. Research has shown that concentrations of BFRs in the environment and in humans are increasing (4). The detection of PBDEs in human breast milk raises concerns regarding the persistence, bioaccumulation, and potential for toxicity in humans and animals. Little is known about the fate of BFRs once they are released into the environment.

Sources of aquatic toxicity in textile wastewaters include salt, surfactants, ionic metals and their metal complexes, toxic organic chemicals, biocides, and toxic anions. Salt has been identified as a potential problem because large quantities of salt are often needed to improve dye fixation onto fibers (2). The salts most commonly used in textile processes are sodium chloride and sodium sulfate. Magnesium chloride and potassium chloride are used less frequently. Surfactants are widely used in textile processes, and can be a large contributor to effluent aquatic toxicity (2). Since salt and surfactants are not reported to TRI or PCS by textile mills, EPA does not have characterization data for these parameters.

5.4.5.4 Pollutant Prevention and Treatment Technology

Most direct-discharging facilities reporting to TRI use aerobic biological treatment. Table 5-75 lists the treatment technologies used by textile mills reporting to TRI for 2000.

**Table 5-75. Wastewater Treatment Operations Reported By Textile Mills,
TRI Reporting Year 2000**

Wastewater Treatment Process	Number of Facilities Reporting Use	
	Direct Dischargers ¹ (22 facilities)	Indirect Dischargers ¹ (30 facilities)
Aerobic Biological Treatment	17	4
Anaerobic Biological Treatment	1	1
Settling/Clarification	19	13
Sludge Dewatering (Nonthermal)	9	9
Thermal Drying/Dewatering	0	1
Emulsion Breaking - Chemical	0	3
Equalization	13	13
Filtration	9	11
Oxidation	5	1
Neutralization	10	15
Chemical Precipitation - Other	3	8
Chemical Precipitation - Lime or Sodium Hydroxide	2	6
Chemical Precipitation - Sulfide	1	0
Cyanide Oxidation	1	0
Other Physical Treatment	2	0
Oil Skimming	2	1
Other Chemical Treatment	3	2
Air Flootation	1	2
Other Blending	1	2
Other Liquid Phase Separation	1	1

Source: EPA, Section 7A Table of the TRI 2000 Database.

¹Of the facilities that provided information on their wastewater treatment operations to TRI in 2000, 22 facilities reported direct releases, 30 reported transfers to POTWs, and 1 reported both direct releases and transfers to POTWs.

The treatment and control technologies used by indirect dischargers in the 1996 Preliminary Study include:

- Biological Treatment;
- Equalization;
- Filtration;
- Neutralization;

- Oil-Water Separation;
- Screening;
- Sedimentation;
- Sulfide Oxidation; and
- Temperature.

The 1996 Preliminary Study compares water use for the textile industry in 1993 and 1980. In 1980, textile water use was, on average, 15.1 gal/lb of fiber processed. In 1993, the water use was, on average, to 11.7 gal/lb of fiber processed. This 22-percent reduction in water use resulted from more efficient use of water in wet processing and the development of water conservation programs at textile mills throughout the industry (1). Comparable information on production-normalized water use for 2000 was not available in the data sources EPA consulted for this review. Examples of water reuse at textile mills include:

- Print screen rinse water is reused for rinsing;
- Rinses from scouring machines are reused in scouring process; and
- Sizing chemicals are reused after being removed from fabric.

In addition to water reuse, other pollution prevention practices reported in the 1996 Preliminary Study included:

- Alternative process chemicals (e.g., biodegradable, water soluble);
- Process changes (e.g., dyeing, sizing); and
- Equipment changes (e.g., dye machinery).

5.4.5.5 Industry Trends

EPA last studied the textile industry in 1996 (1). Table 5-76 compares the textile industry as presented in the 1996 Preliminary Study with 1997 Economic Census data and TRI data for 2000. Although the total number of establishments has decreased, the results of this review are consistent with the 1996 Preliminary Study finding that about half of the textile mills are in wet processing SIC codes, and a large percentage of discharges from textile mills are transferred to POTWs.

Table 5-76. Comparison of Industry Statistics

	1996 Preliminary Study	2000 Review
Total number of establishments	5,887 mills in 1992 Census of Manufacturers	4,792 mills in 1997 Economic Census
Percentage of establishments in wet processing SIC codes	35-50%	50% of mills in 1997 Economic Census
Percent of establishments that discharge to POTWs	91-96%	80% of the 72 mills reporting discharges to TRI for 2000

Source: EPA, Preliminary Study of the Textile Mills Point Source Category, 1996; U.S. Economic Census, 1997; and EPA, *TRI Releases 2000*.

5.4.5.6 Stakeholder and EPA Regional Issues

Stakeholder and EPA Regional issues identified during this review are summarized below:

- In general, stakeholders were concerned with industrial sludge disposal, and based on an EPA Region 4 poll, stakeholders expressed a need for a measurable limit for color and copper.
- The source for releases of color and copper is the dyeing process.
- Because facilities are not required to report color releases to TRI and PCS, available data are not sufficient to evaluate color discharges for this industry. Only one facility reported color releases to PCS.
- Copper releases account for less than 1 percent of the total TWPE in TRI and PCS.

EPA did not receive any public comments on the December 31, 2003 Preliminary Effluent Guidelines Program Plan, FRN [**FRL-7604-7**] from this industry.

5.4.5.7 Conclusions

Pollutants driving the total TWPE for this industry are sulfide and chlorine. Based on 2000 PCS data, sulfide accounts for 50 percent of the total TWPE for the textile industry. Currently, every wet processing subcategory under 40 CFR Part 410 contains limitations under BPT and BAT for sulfide. According to the 1996 Preliminary Study, some textile mills use sulfide oxidation as a pretreatment technology to reduce sulfide concentrations. At this time, EPA has not identified any other pollution prevention or treatment processes to lower sulfide releases. 2000 TRI and PCS data showed high TWPE values for chlorine, which accounts for 37 percent of the PCS TWPE and 90 percent of the TRI TWPE.

The number of facilities reporting to TRI for 2000 represents only about 5 percent of the textile industry based on the total number of textile mills in the 1997 Economic Census, while the number of facilities reporting discharges to PCS for 2000 represent less than 2 percent of the total industry. Consequently, the reported pollutant discharges may not accurately characterize the entire textile industry. In comparison, the 1996 Preliminary Study presents year 1992 TRI data for 228 textile mills and 1994 PCS data for 59 textile mills. When compared to the 1992 Census count of textile mills, the 1992 TRI data represent only about 4 percent of textile mills, and PCS data represent only about 1 percent of textile mills in the United States. Other data quality concerns include:

- Releases reported to TRI might be based on estimates, not measurements, and tend to overestimate actual discharges.
- Total residual chlorine discharges reported to PCS may reflect daily maximum concentration. Thus, loads calculated from this maximum concentration represent a maximum pollutant mass discharge.

Textile mills may release compounds that are not reported to TRI or in PCS, such as BFRs used in textile finishing processes. BFRs are bioaccumulative and persistent chemicals that have been detected in the environment and in humans. However, EPA does not currently have actual data for these chemicals. EPA is concerned about persistent bioaccumulative compounds and has formed a task force to consider these compounds further. The ELG program will follow the work of this task force and plans to incorporate relevant suggestions/concerns into future planning activities. In the next annual review, EPA will continue to obtain and consider information to fill remaining data gaps.

5.4.5.8 References

1. U.S. EPA. *Preliminary Study of the Textile Mills Category*. Washington, D.C. 1996.
2. U.S. EPA. *Clean Technologies in U.S. Industries: Focus on Textiles*. 1997. Available online at: http://www.usaep.org/resources/reports/rep_cleantech_text.html.
3. U.S. EPA. 2003. *Proposed Significant New Use Rule for Flame Retardants in Residential Upholstered Furniture: Evaluation of Releases and Occupational Exposures*. Report prepared by ERG, Inc. Chantilly, VA.
4. Birnbaum, L., and Staskal, D. "Brominated Flame Retardants: Cause for Concern?" *Environmental Health Perspectives*, 112:9-17. 2004.

5. U.S. EPA. *Development Document for Effluent Limitations Guidelines and Standards for the Textile Mills Point Source Category*. EPA-440/1-79/022b. Washington, D.C. 1979.

5.4.6 Timber Products Processing Point Source Category

5.4.6.1 Industry Description

As defined in 40 CFR Part 429.10, the Timber Products Processing Point Source Category includes all facilities with timber products processing operations and any plant producing insulation board with wood as the major raw material. Products manufactured by this category include veneer, plywood, hardboard, preserved wood (pressure and non-pressure-treated), particle board, and wood furniture and fixtures. Operations covered by this category are included in the six SIC codes presented in Table 5-77.

Table 5-77. Timber Products Processing SIC Code Descriptions

SIC Code	Description	Activities
2421	Sawmills & Planing Mills, General	Sawing rough lumber and timber from logs and bolts; sawing box lumber and softwood cut stock; planing mills combined with sawmills; and separately operated planing mills.
2435	Hardwood Veneer and Plywood	Producing commercial hardwood veneer and manufacturing plywood or prefinished hardwood plywood.
2436	Softwood Veneer & Plywood	Producing commercial softwood veneer and plywood from veneer produced in the same establishment or from purchased veneer.
2491	Wood Preserving	Treating wood, sawed, or planed in other establishments, with creosote or other preservatives to prevent decay and to protect against fire and insects.
2493	Reconstituted Wood Products	Manufacturing reconstituted wood products, such as hardboard, particleboard, insulation board, medium density fiberboard, waferboard, and oriented strand board.
2499	Wood Products, NEC	Manufacturing miscellaneous wood products, and products from rattan, reed, splint, straw, veneer, wicker, and willow.

EPA obtained information on the number of facilities included in each SIC code from three sources: the 1997 U.S. Economic Census, and EPA's TRI and PCS databases for 2000. Table 5-78 lists the number of facilities by SIC code from these sources. The TRI-reporting facilities in Table 5-78 include facilities reporting releases to any medium, even those that reported no wastewater releases. In contrast, the PCS-reporting facilities include only facilities that are permitted to discharge to surface waters. The number of facilities reporting to TRI for 2000 represent only about 4 percent of the total industry, based on total number of facilities in the 1997 Economic Census. One sector of the industry, wood preserving, is relatively better represented in TRI. The number of wood preserving facilities reporting to TRI

for 2000 represents about 32 percent of the wood preserving facilities in the 1997 Economic Census.

Table 5-78. Number of Facilities in Timber Products Processing SIC Codes

SIC Code	Description	1997 U.S. Economic Census	2000 TRI-All Dischargers	2000 PCS	
				Major Dischargers	Minor Dischargers
2421	Sawmills & Planing Mills, General	5,176	33	2	102
2435	Hardwood Veneer and Plywood	332	8	0	13
2436	Softwood Veneer & Plywood	155	46	2	12
2491	Wood Preserving	451	144	1	19
2493	Reconstituted Wood Products	316	108	4	15
2499	Wood Products, NEC	2,842	33	2	13
Total		9,272	372	11	174

Source: EPA, *TRIRelases2000* and *PCSLoads2000* and 1997 U.S. Economic Census.

Table 5-79 presents the number of facilities reporting to TRI by type of discharge. This table shows that the majority of facilities reporting to TRI did not report releasing TRI chemicals to surface waters or POTWs. However, the wood preserving industry does not follow this trend, in that more than half of the facilities in SIC code 2491 reported a direct or indirect wastewater discharge.

Operations in timber products processing are primarily located in the South and Northwest.

Table 5-79. Number of Timber Products Processing Facilities by Discharge Type (TRI 2000)

SIC Code	Description	Total Reporting to TRI	Direct Dischargers Only	Indirect Dischargers Only	Both Direct and Indirect Dischargers	No Reported Wastewater Discharge
2421	Sawmills & Planing Mills, General	33	2	1	0	30
2435	Hardwood Veneer and Plywood	8	0	0	0	8
2436	Softwood Veneer & Plywood	46	0	1	0	45
2491	Wood Preserving	144	49	5	21	69
2493	Reconstituted Wood Products	108	6	9	4	89
2499	Wood Products, NEC	33	3	1	0	29
Total		372	60	17	25	270

Source: EPA, *TRIRelases2000*.

5.4.6.2 Regulatory Background

EPA promulgated the existing regulations (40 CFR Part 429) for the Timber Products Processing category in stages, between April 1974 and November 1981. These regulations divide this category into 16 subparts (subcategories), as summarized in Table 5-80. The subcategories are generally defined by combinations of products made and the processes used to make these products. They are not generally defined by SIC code. Regulations for the timber products processing subcategories may apply to one SIC code, multiple SIC codes, or a portion of the facilities in an SIC code. Table 5-80 presents the general relationship between SIC codes and timber products processing subcategories as well as the current ELGS for this industry.

BAT regulations for 11 subcategories require no discharge of process wastewater. This is compatible with the information presented in Table 5-79, in that more than 70 percent of the timber products processing facilities reporting to TRI reported no wastewater releases of pollutants. In 40 CFR Part 429.11, the term “process wastewater” specifically excludes noncontact cooling water, material storage yard runoff (either raw material or processed wood storage), and boiler blowdown. For the dry process hardboard, veneer, finishing, particleboard, and sawmills and planing mills subcategories, fire control water is excluded from the definition. Thus, all timber products processing facilities may be permitted to discharge noncontact cooling water, storage yard runoff, and fire control water. In addition, barking, wet storage, and log washing operations may be located at facilities with primary operations in subcategories for which BPT and/or BAT is “no discharge of process wastewater.” Because there are ELG for barking, wet storage, and log washing, facilities may be permitted to discharge wastewaters from these operations.

Thus, even though BAT guidelines for two of the three wood preserving subcategories require “no discharge of process wastewater,” facilities in all three wood preserving subcategories may be permitted to discharge storage yard runoff, which might be contaminated with wood preserving chemicals, as well as noncontact cooling water, and wastewaters from any on-site barking, wet storage, and log washing operations.

PSES regulations for all but two subcategories require discharging facilities to comply with the general pretreatment standards in 40 CFR Part 403. EPA established PSES for two wood preserving subcategories, G - Steam and H - Boulton. The standards are the same for both subcategories and include maximum concentrations for any one day, for four pollutants:

- Oil and grease, 100 mg/L;
- Copper, 5 mg/L;
- Chromium, 4 mg/L; and
- Arsenic, 4 mg/L.

Table 5-80. Pollutants Regulated by Existing Timber Products Processing ELGS

40 CFR Part	Subcategory	Approximate SIC Code	SIC Code Description	BPT	BAT	NSPS
A	Barking	Major Group 24, facilities that bark logs		BOD ₅ , TSS, pH	Reserved	BOD ₅ , TSS, pH
B	Veneer	2435 and 2436, without wet storage	Hardwood and Softwood Veneer and Plywood	BOD ₅ , pH	No discharge of process wastewater pollutants	No discharge of process wastewater pollutants
C	Plywood	2435 and 2436, without wet storage	Hardwood and Softwood Veneer and Plywood	No discharge of process wastewater ¹ pollutants	No discharge of process wastewater ¹ pollutants	No discharge of process wastewater ¹ pollutants
D	Dry Process Hardwood	2493, hardboard using dry matting	Reconstituted Wood Products	No discharge of process wastewater ¹ pollutants	No discharge of process wastewater ¹ pollutants	No discharge of process wastewater ¹ pollutants
E	Wet Process Hardwood	2493, hardboard using wet matting	Reconstituted Wood Products	BOD ₅ , TSS, pH	Reserved	No discharge of process wastewater ¹ pollutants
F	Wood Preserving - Water-Borne or Nonpressure	2491, CCA and other inorganics	Wood Preserving	No discharge of process wastewater ¹ pollutants	No discharge of process wastewater ¹ pollutants	No discharge of process wastewater ¹ pollutants
G	Wood Preserving - Steam	2491, oil borne and combination	Wood Preserving	COD, Oil & Grease, phenols, pH	Reserved	No discharge of process wastewater ¹ pollutants
H	Wood Preserving - Boulton	2491, oil borne	Wood Preserving	No discharge of process wastewater ¹ pollutants	No discharge of process wastewater ¹ pollutants	No discharge of process wastewater ¹ pollutants

Table 5-80 (Continued)

40 CFR Part	Subcategory	Approximate SIC Code	SIC Code Description	BPT	BAT	NSPS
I	Wet Storage	Major Group 24, facilities with wet log storage		pH, debris	pH, debris	pH, debris
J	Log Washing	Major Group 24, facilities with log washing		TSS, pH	No discharge of process wastewater ¹ pollutants	No discharge of process wastewater ¹ pollutants
K	Sawmills and Planing Mills	2421, except hydraulic barking	Sawmills & Planing Mills, General	No discharge of process wastewater ¹ pollutants	No discharge of process wastewater ¹ pollutants	No discharge of process wastewater ¹ pollutants
L	Finishing	Not defined by SIC; includes staining, moisture proofing, etc. at timber processing operations		No discharge of process wastewater ¹ pollutants	No discharge of process wastewater ¹ pollutants	No discharge of process wastewater ¹ pollutants
M	Particleboard Manufacturing	2493, particleboard	Reconstituted Wood Products	No discharge of process wastewater ¹ pollutants	No discharge of process wastewater ¹ pollutants	No discharge of process wastewater ¹ pollutants
N	Insulation Board	2493, wood insulation board (excludes bagasse)	Reconstituted Wood Products	BOD ₅ , TSS, pH	Reserved	No discharge of process wastewater ¹ pollutants
O	Wood Furniture and Fixture Production Without Water Wash Spray Booth(s) or Laundries	2499	Wood products, NEC	No discharge of process wastewater ¹ pollutants	No discharge of process wastewater ¹ pollutants	No discharge of process wastewater ¹ pollutants
P	Wood Furniture and Fixture Production With Water Wash Spray Booth(s) or Laundries	2499	Wood products, NEC	TSS, pH	No discharge of process wastewater ¹ pollutants	No discharge of process wastewater ¹ pollutants

Source: *Code of Federal Regulations*, <<http://www.epa.gov/epahome/cfr40.htm>>.

¹The term "process wastewater" specifically excludes noncontact cooling water, material storage yard runoff (either raw material or processed wood storage), and boiler blowdown. For the dry process hardboard, veneer, finishing, particleboard, and sawmills and planing mills subcategories, fire control water is excluded from the definition.

Technology Basis for Existing Limitations

Table 5-81 summarizes the technology basis for existing limitations.

Table 5-81. Summary of Technology Basis of Existing Timber Products ELGS

Subcategory	BPT	BAT	PSES
F - Wood Preserving-Water-Borne or Nonpressure	No discharge of process wastewater based on recovery and reuse of contaminated water as make-up water for treating solutions (4).	BAT (no process wastewater discharge) based on process controls such as use of surface condensers rather than barometric condensers or recycle of barometric condenser cooling water, and on-site disposal techniques, such as containment and spray-evaporation and/or spray irrigation to eliminate discharges to surface waters (3).	Comply with 40 CFR Part 403.
G - Wood Preserving - Steam	Limits based on in-plant controls, oil/water separation, and biological treatment (4).	Reserved.	Limits based on oil/water separation and the rationale that the 100 mg/L oil and grease limit would control pentachlorophenol discharges to 15 mg/L or less (3).
H - Wood Preserving - Boulton	No discharge of process wastewater based on leak and spill control and disposal of small wastewater volumes by evaporation or percolation (4).	See Subpart F.	See Subpart G.
Others	Limits for insulation board and wet process hardboard, based on primary and secondary treatment, with reuse of a portion of the treated wastewater (4).	Most other subcategories have a "no discharge of process wastewater" requirement, based on internal controls and reuse of recovered wastewater (3 and 4).	Comply with 40 CFR Part 403.

Sources: EPA, 1974 and 1981 Development Documents (3 and 4).

Stormwater Multi-Sector General Permit

Timber products processing facilities are covered by EPA's multi-sector general permit (MSGP) for industrial stormwater discharges. The MSGP authorizes stormwater discharges associated with industrial activities covered by ELGS. The timber products processing industry is included as Industrial Sector A in the MSGP. The MSGP requirements apply only in the five states for which EPA issues permits. Most of the remaining states issue general stormwater permits that, at a minimum, generally contain the same requirements as the MSGP. EPA or other permitting authority may require an individual permit for a facility instead of coverage under the MSGP or general permit. For example, the state of Alabama does not issue general stormwater permits for wood preserving facilities. Instead, each facility is issued

an individual NPDES permit. For most of these facilities, the permitted wastewater discharge is stormwater (6). The MSGP includes the following permit conditions:

- Facilities must submit a “Notice of Intent” to discharge stormwater prior to receiving authorization to discharge.
- Facilities must prepare and implement a Stormwater Pollution Prevention Plan (SWPPP).
- Facilities must conduct chemical analytical monitoring of specified benchmark parameters to determine if a stormwater discharge merits further monitoring. The MSGP provides benchmark levels that represent target concentrations for a facility to achieve by implementing pollution prevention measures.

Wood preserving facilities are subject to benchmark monitoring for arsenic and copper. They are required to monitor once per quarter for monitoring years 2 and 4. The wood preserving sector-specific benchmark cut-off concentrations are:

Total Arsenic	0.16854 mg/L.
Total Copper	0.0636 mg/L.

Resource Conservation and Recovery Act (RCRA) Hazardous Waste Regulations

As discussed in the *Preliminary Data Summary for the Wood Preserving Segment of the Timber Products Processing Point Source Category (5)*, in 1990, EPA issued final regulations that specifically listed wood preserving wastes from facilities that use chlorophenolic formulations, creosote formulations, and inorganic preservatives containing arsenic or chromium as hazardous wastes. The types of wastes identified include wood preserving wastewaters, process residuals, preservative drippage, and spent preservatives. In addition to identifying specific wood preserving wastes as hazardous, EPA identified a “drip pad” as a new RCRA hazardous waste management unit unique to wood preserving facilities. EPA developed specific standards (referred to as RCRA Subpart W standards) for the design, installation, operation, and closure of hazardous waste drip pads.

Preservative drippage and process residuals might accumulate on drip pads, in pathways over which treated wood is transported, and in treated wood storage yards. This category of waste includes drippage of preservative from treated wood, preservative that is washed off treated wood by rainwater, and residuals from collecting and recycling preservative that drips off or is washed off treated wood. However, preservative that is washed off treated wood in storage yards by rainwater is not specifically identified as a RCRA listed waste.

Existing Regulatory Conclusions

After its preliminary review of existing regulations for SIC code 2491 (wood preserving), EPA come to the following conclusions:

- Even though BAT guidelines for two of the three wood preserving subcategories are “no discharge of process wastewater,” facilities in all three wood preserving subcategories may be permitted to nonprocess discharge storage yard runoff, which may be contaminated with wood preserving chemicals, as well as noncontact cooling water and wastewaters from any on-site barking, wet storage, and log washing operations.
- Wood preserving facilities are subject to EPA’s MSGP or general stormwater permits issued by the states, unless a permitting authority issues individual NPDES permits for stormwater discharges. MSGP and general stormwater permits require baseline monitoring for arsenic and chromium, but not for constituents of organic wood preservatives, such as PACs, pentachlorophenol, or dioxins (dioxins are potential contaminants of pentachlorophenol).
- Preservative that is washed off treated wood in storage yards by rainwater is not specifically identified as a RCRA-listed waste and is not subject to RCRA hazardous waste treatment, storage, and disposal regulations unless it exhibits a characteristic hazard (such as toxicity).

5.4.6.3 Wastewater Characteristics and Pollutant Sources

This subsection presents the wastewater characteristics of facilities reporting to PCS and the pollutants that contribute the most to the pollutant load reported in each SIC code by facilities in *TRIRelases2000* and *PCSLoads2000*. This subsection also describes an analysis of stormwater discharges of wastewater pollutants.

Wastewater Characteristics Reported in PCS

Ten of the 11 major dischargers reporting to PCS also report discharge outfall flow rates. Flow rates are not available for the 174 facilities identified as minor dischargers. Table 5-82 presents the total annual flow (in million gallons) for 2000 and range of facility flows for each SIC code. Facilities not reporting a flow were not included in the calculation of the median. As noted in Table 5-82, BAT limitations for most of the timber products processing subcategories is “no discharge of process wastewater,” although facilities may be permitted to discharge material storage yard runoff and other nonprocess wastewaters. Only 0.1 percent of the timber products processing facilities in the 1997 Economic Census had discharge flow rates in *PCSLoads2000*. Thus, the reported flows are not likely to characterize the entire industry.

Table 5-82. Timber Products Wastewater Flows Reported to PCS for 2000

SIC Code	Description	Applicable Subparts	BAT	Number of Major Facilities Reporting Nonzero Flows	Range of Facility Flows in 2000 (MGY)	Total Flow in 2000 (MGY)
2421	Sawmills & Planing Mills, General	K	No discharge of process wastewater ¹	1	NA	900
2435	Hardwood Veneer and Plywood	B & C	No discharge of process wastewater ¹	0	NR	NR
2436	Softwood Veneer & Plywood	B & C	No discharge of process wastewater ¹	2	110 - 701	811
2491	Wood Preserving	F - Water-Borne G - Steam Conditioning H - Bolton Conditioning	No discharge ¹ BPT limits, BAT reserved no discharge ¹	0	NR	NR
2493	Reconstituted Wood Products	D - Dry Hardboard E - Wet Hardboard M - Particle Board N - Insulation Board	No discharge ^a BPT limits, BAT reserved no discharge ¹ BPT limits, BAT reserved	4	326 - 2,002	3,780
2499	Wood Products, NEC	O & P	No discharge of process wastewater ¹	2	246 - 256	501
Total				10		5,993

Source: EPA, *PCSLoads2000*.

NA - Not applicable; only one facility reported flow rate.

NR - No reported flow.

¹The term "process wastewater" specifically excludes noncontact cooling water, material storage yard runoff (either raw material or processed wood storage), and boiler blowdown. For the dry process hardboard, veneer, finishing, particleboard, and sawmills and planing mills subcategories, fire control water is excluded from the definition. In addition, discharges from barking, wet storage, and log washing located at timber products processing facilities may be permitted using guidelines for Subparts A, I, and J.

Table 5-83 presents the chemicals reported to PCS that account for 95 percent of the total TWPE for each SIC code. No wastewater discharges for facilities with SIC codes 2421 and 2491 were reported to PCS. One facility in SIC code 2436, Softwood Veneer and Plywood, reported discharge of several metal pollutants. This facility did not comply with its

copper limits in seven of eight quarters in 2002-2004. None of the other facilities reporting to PCS had apparent compliance problems.

Table 5-83. Timber Products Processing Pollutant Discharges Reported to PCS for 2000

SIC Code	Pollutant	Number of Facilities Reporting	PCS Total (lbs/yr)	PCS TWPE/yr	Median Facility TWPE/yr	Percentage of Total SIC Code TWPE
2436 ¹	Lead, Total Recoverable	1	31	69	69	49%
	Iron, Total Recoverable	1	5,622	31	31	22%
	Copper, Total Recoverable	1	31	20	20	14%
	Chlorine, Total Residual	1	20	10	10	7%
	Cadmium, Total Recoverable	1	3	8	8	6%
2493 ²	Chlorine, Total Residual	2	1,126	548	274	67%
	Copper, Total (As Cu)	1	196	123	123	15%
	Zinc, Total (As Zn)	1	1,045	49	49	6%
	Chromium, Hexavalent (As Cr)	1	86	44	44	5%
	Nitrogen, Ammonia Total (As N)	1	19,886	36	36	4%
2499 ³	Phenolics, Total Recoverable	1	5	0.1	0.1	100%

Source: EPA, *PCSLoads2000*.

¹Softwood Veneer & Plywood, loads from one facility that was not complying with copper limits from April 2002 to March 2004.

²Reconstituted Wood Products.

³Wood Products, NEC.

Wastewater Characteristics Reported in TRI

As discussed in Section 4.2.4.2, in the screening-level review of the 2000 TRI data, EPA used a median toxic-weighting factor of the 17 dioxin and dioxin-like compounds to represent a toxic-weighting factor for this class of compounds. For the Timber Products Processing category review, EPA recalculated the estimated toxic-weighted pounds of dioxins using the TRI-reported congener distributions. For facilities that reported dioxin congener distributions, EPA calculated TWPE using the congener distributions and TWFs of the individual dioxin compounds. For facilities that did not report a dioxin congener distribution, EPA used the average distribution of the reporting facilities to recalculate TWPE.

In the screening-level review, EPA estimated that wood preserving facilities (SIC code 2491) released 5,359,154 TWPE of dioxins. EPA's revised estimate, based on reported congener distribution, is 379,324 TWPE. EPA notes that 2000 was the first year that facilities were required to report dioxin releases to TRI. See Section 4.2.4.2 for issues related to dioxin reporting.

For the screening-level review of the 2000 TRI data, EPA assumed that the only PAC reported to be discharged by timber products processing facilities was benzo(a)pyrene. Thus, EPA used the toxic-weighting factor (TWF) for benzo(a)pyrene to estimate the TWPE of PACs released by wood preserving facilities. For this review, EPA assumed that composition of PACs released by the timber products processing facilities is proportional to the PACs composition of creosote. EPA made this assumption and revised its methodology accordingly because facilities that reported PACs to TRI also reported discharging creosote. Because creosote contains PACs, EPA assumed that the source of the PACs is creosote. Using this methodology, the TWF for the PACs category is reduced from 4,284 to 65.78, which reduces the total TWPE for PACs from 1,051,876 to 16,153.

Table 5-84 presents the pollutants reported to TRI as discharged directly or indirectly that account for 95 percent of the total TWPE for each SIC code. This table presents the number of facilities that reported each pollutant, total pounds of pollutant discharged for each SIC code, and total TWPE for each pollutant. Note that this table reflects information as reported to TRI and that EPA has not verified this information.

As with PCS, no facilities in SIC code 2435, Hardwood Veneer and Plywood, reported wastewater pollutant releases.

Two facilities in SIC code 2421, Sawmills and Planing Mills, reported releases of arsenic, copper, and chromium, metals that are the active ingredients in inorganic wood preservatives.

The most releases, both in terms of number of facilities reporting and TWPE, were reported by facilities in SIC code 2491, Wood Preserving. Dioxin and dioxin-like compounds have the highest TWPE reported to TRI among the six SIC codes and were reported to TRI by approximately 25 percent of the discharging wood preserving facilities. Releases of coal tar creosote were reported by 29 wood preserving facilities. However, because there is no toxic-weighting factor for creosote, it does not contribute to the total TWPE discharged by facilities in SIC code 2491. There are no pretreatment standards or ELGS for any of the pollutants identified in Table 5-84 that are discharged by wood preserving facilities.

The information in Tables 5-83 and 5-84 provides the basis of the following conclusions:

- More than 93 percent of the TWPE discharges reported to TRI for 2000 were discharges of dioxin and dioxin-like compounds from SIC code 2491 (wood preserving);
- If EPA assumes a toxic-weighting factor for creosote based on its chemical composition, creosote would add 126,000 TWPE to the total TWPE for this industry;

- Based on the information reported to TRI, compared to wood preserving, toxic discharges from other timber products processing SIC codes are low;
- Very little information about discharges of toxic pollutants from this industry is included in PCS; and
- Because process wastewater discharge is prohibited, pollutant discharges from most subcategories most likely originate from noncontact cooling water, material storage yard runoff (either raw material or processed wood storage), and boiler blowdown, fire control water, barking, wet storage, or log washing. Of these sources, runoff from preserved wood storage is the most likely source of pollutants.

Table 5-84. Timber Products Processing Pollutant Releases to Surface Water Reported to TRI for 2000

SIC Code	Description	Pollutant	Number of Facilities Reporting Pollutant/Any Wastewater	TRI Total (lbs/yr)	TRI-TWPE/yr	Median Facility TWPE/yr	Range of Facility TWPE/yr	Percent of Total SIC Code TWPE
2421	Sawmills & Planing Mills, General	Arsenic compounds	2 of 3	260	902	451	17 - 885	75%
		Copper compounds	2 of	260	163	81	3 - 160	14%
		Chromium compounds	2 of 3	260	133	67	3 - 131	11%
2436	Softwood Veneer & Plywood	Methyl methacrylate	1 of 1	23	0.007	0.007	NA	100%
2491	Wood Preserving	Creosote	29 of 75	37,994	NC	NC	NC	NC
		Dioxin and dioxin-like compounds	24 of 75	0.8	379,324	3,825	75 - 122,187	94%
		Polycyclic aromatic compounds	6 of 75	246	16,153	375	39 - 12,865	4%
2493	Reconstituted Wood Products	Ammonia	4 of 19	21,112	32	1	0.4 - 30	57%
		Formaldehyde	12 of 19	5,516	13	1	0.01 - 8	23%
		Phenol	2 of 19	260	7	4	0.1 - 7	13%
		1,2,4-Trichlorobenzene	1 of 19	35	3	3	NA	5%
2499	Wood Products, NEC	Dioxin and dioxin-like compounds	1 of 4	0.0004	184	184	NA	98%

Source: EPA, *TRIRelases 2000*.

NC - Not calculated. Creosote does not have a toxic-weighting factor; therefore, no TWPE is calculated.

NA - Not applicable; only one facility reported pollutant discharge.

Wastewater Pollutant Sources

This subsection describes the sources of wastewater discharged to receiving streams by wood preserving facilities (SIC code 2491). Because wood preserving facilities account for almost all of the TRI-reported releases of TWPE for the Timber Products Processing category, EPA's review of timber products wastewater pollutant sources focused on the wood preserving industry.

As described in the 1991 PDS (1), the major sources of wastewater in the wood preserving industry are internal wood water, which is removed from the wood during the conditioning process, and steam condensate, which is generated during conditioning. The wood water and steam condensate become contaminated from contact with wood constituents, oil and grease, and preservative. Other sources of wastewater include wastewater generated during preservative formulation recovery and regeneration, drippage and spills from the retort, other miscellaneous sources, and stormwater runoff.

TRI requires facilities to estimate on-site releases of toxic chemicals, including discharges to receiving streams. Some facilities monitor stormwater runoff chemical concentrations. TRI requires facilities that monitor stormwater to report the percentage of the total quantity of the chemical discharged that was contributed by stormwater.

The BPT limitations guidelines for Timber Products Subpart F (Wood Preserving - Water-borne or Nonpressure Subcategory) and Subpart H (Wood Preserving - Boulton Subcategory) require "no discharge of process wastewater pollutants." However, the definition of process wastewater specifically excludes material storage yard runoff. Thus, wood preserving facilities may be permitted to release material storage yard runoff and other stormwater.

EPA analyzed information reported to TRI to determine if the reported pollutant releases originated from stormwater or from other sources. EPA determined the number of wood preserving facilities that reported stormwater contributions to their wastewater discharges. EPA found that, of the 75⁵ wood preserving facilities that reported discharging wastewater to TRI, 51 facilities reported that stormwater contributes 100 percent of the mass of the chemicals they released to surface waters.

Table 5-85 lists the chemicals that account for 90 percent of the total, un-weighted pounds of pollutants released by all wood preserving facilities reporting to TRI. In contrast, Table 5-86 lists the total TWPE of pollutants released, and lists the one chemical group, dioxin and dioxin-like compounds, that accounts for more than 90 percent of the total TWPE released by all wood preserving facilities reporting to TRI. Each table lists the number of facilities that reported releasing the chemical. For each chemical, the tables also lists the number of facilities

⁵The 75 facilities in SIC code 2491, Wood Preserving, that reported wastewater discharges to TRI, include 49 that reported only releases to surface water, 21 that reported transfers to POTWs, and 5 that reported both releases to surface water and transfers to POTWs.

that reported the percentage contributed by stormwater. Finally, each table lists the number of facilities that reported that stormwater contributed 100 percent of the quantity of chemical discharged.

Table 5-85. Stormwater Discharges of Pollutants Accounting for 90 Percent of Unweighted Pounds of Wood Preserving Pollutant Loads

Chemical	Releases Reported to TRI (Pounds)	Percentage of SIC 2491 Total TRI Pounds	Number of Facilities Reporting Releasing the Chemical	Number of Facilities Providing Percentage Contributed by Stormwater	Number of Facilities That Report 100 Percent of the Discharge is from Stormwater
Creosote, Coal Tar	37,994	82%	29	29	20
Chromium Compounds	2,183	5%	25	24	15
Arsenic Compounds	1,523	3%	22	22	14

Source: EPA, *TRIReleases2000*.

Table 5-86. Stormwater Discharges of Pollutant Accounting for 90 Percent of Wood Preserving TWPE

Chemical	Releases Reported to TRI (TWPE)	Percentage of SIC 2491 Total TRI TWPE	Number of Facilities Reporting Releasing the Chemical	Number of Facilities Providing Percentage Contributed by Stormwater	Number of Facilities That Report 100 Percent of the Discharge is from Stormwater
Dioxin and Dioxin-Like Compounds	379,324	94%	24	24	21

Source: Section 5 Table of the TRI 2000 Database.

As shown in Table 5-86, of the 24 facilities reporting percentage of the mass of dioxins released that derived from stormwater, 21 facilities reported that stormwater contributed 100 percent of the released mass. Of the three facilities that did not report 100 percent stormwater discharge of dioxins, two were direct dischargers and one was an indirect discharger.

In addition, as shown in Table 5-85, creosote, chromium compounds, and arsenic compounds account for 90 percent of the total unweighted pounds of toxic chemicals released by all wood preserving facilities reporting to TRI. Over half of the facilities reporting releases of these chemicals reported that 100 percent of the mass discharged was contributed by stormwater.

EPA analyzed reported releases to determine what pollutants were associated with nonstormwater releases. Twenty-four facilities for which usable information was available reported that stormwater contributed less than 100 percent of the mass of chemical they discharged to receiving streams. Table 5-87 lists the chemicals these 24 facilities reported

discharging. Except for dioxin, these chemicals are constituents of wood preservatives. Dioxin is a potential contaminant of pentachlorophenol. The table also lists the number of facilities reporting non-stormwater-derived discharges of these chemicals.

Table 5-87. Nonstormwater Discharges of Pollutants from Wood Preserving Facilities

Chemical	Number of Facilities Reporting That Less than 100 Percent of Their Discharge Is from Stormwater
Chromium Compounds or Chromium	11
Arsenic Compounds or Arsenic	9
Copper Compounds or Copper	8
Creosote, Coal Tar	2
Dioxin and Dioxin-Like Compounds	2
Pentachlorophenol	2

Source: EPA, *TRIReleases2000*.

EPA does not currently have information about the wastewaters that are the source of these pollutant releases.

The information reported to TRI by facilities in SIC code 2491 (wood preserving) provides the basis of the following conclusions:

- Of the 144 facilities reporting to TRI, almost half (69) did not report releasing TRI chemicals to surface water or transferring them to POTWs.
- Of the 75 facilities that reported releasing TRI chemicals to surface water or transferring them to POTWs, 51 facilities reported that stormwater contributes 100 percent of the direct chemical discharges.
- Facilities reporting releases of TRI chemicals that did not originate from stormwater reported releasing chromium, arsenic, copper, creosote, dioxin and dioxin-like compounds, and pentachlorophenol. Except for dioxin, these chemicals are constituents of wood preservatives. Dioxin is a potential contaminant of pentachlorophenol.
- EPA has not identified the nonstormwater sources of TRI-reported chemical releases that are attributable to stormwater.

EAD Preliminary Data Summary

EPA conducted a preliminary characterization study of the wood preserving industry and published the results of that study in 1991(1). As reported in the 1991 PDS, EPA conducted sampling episodes at five wood preserving facilities, four in the Boulton subcategory

and one in the steam subcategory. Two of the five facilities did not discharge process wastewater, while the other three discharged to POTWs and are subject to PSES for oil and grease, copper, chromium, and arsenic. EPA did not sample facilities that treat only with inorganic preservatives, nor did it sample nonprocess wastewater discharges, such as storage yard run-off. EPA did not estimate industry-wide loads of pollutants discharged by wood preserving facilities. For this reason, the information presented in the PDS is not readily comparable to the information reported to TRI or PCS in 2000.

EPA frequently detected toxic and priority pollutants not limited by existing PSES in treated effluents discharged to POTWs. These pollutants included, among many others:

- Dioxins and dioxin-like compounds (including 1,2,3,7,8-PeCDD, 2,,3,7,8-TCDF, and others);
- PACs (including Benzo(j,k)fluorene (fluoranthene), Benzo(a)phenanthrene (chrysene), and others); and
- Pentachlorophenol.

5.4.6.4 Pollution Prevention and Treatment Technology

Table 5-88 lists the treatment technologies used by timber products processing facilities reporting to TRI for 2000. Timber products processing facilities use biological treatment more than any other wastewater treatment processes. Three types of biological treatment have been used by this industry: aerobic, anaerobic, and facultative. Biological treatment reduces concentrations of COD, total phenols, oil and grease, pentachlorophenol, and organic compounds in wastewater. This treatment is normally used as a pretreatment step prior to discharge to a POTW (1).

Table 5-88. Wastewater Treatment Operations Reported By Timber Products Processing Facilities TRI Reporting Year 2000

Wastewater Treatment Process	Number of Facilities Reporting Use	
	Direct Dischargers ¹ (37 facilities)	Indirect Dischargers ¹ (25 facilities)
Biological Treatment	22	17
Settling/Clarification	16	10
Equalization	9	6
Adsorption -- Carbon	9	5
Oil Skimming	7	2
Filtration	6	2
Emulsion Breaking -- Chemical	6	4

Table 5-88 (Continued)

Wastewater Treatment Process	Number of Facilities Reporting Use	
	Direct Dischargers ¹ (37 facilities)	Indirect Dischargers ¹ (25 facilities)
Chemical Precipitation -- Other	3	2
Sludge Dewatering (Nonthermal)	3	1
Air Flotation	3	1
Neutralization	2	1
Thermal Drying/Dewatering	2	0
Other Incineration/thermal Treatment	2	0
Other Liquid Phase Separation	2	0
Other Physical Treatment	2	0
General Oxidation (Including Disinfection) -- Ozonation	1	2
General Oxidation (Including Disinfection) -- Other	1	1
Other Chemical Treatment	0	1
Stripping -- Air	0	1

Source: EPA, Section 7A Table of the TRI 2000 Database.

¹Of the facilities that provided information on their wastewater treatment operations in TRI 2000, 37 facilities reported direct releases, 25 reported transfers to POTWs, and 19 reported both direct releases and transfers to POTWs.

5.4.6.5 Industry Trends

Wood preserving is the major source of toxic releases reported by this industrial category. Stormwater discharges reported to TRI include creosote, chromium, arsenic, and the potential pentachlorophenol contaminant, dioxins. Wood preservers have voluntarily agreed to cancel certain chromated copper arsenate (CCA) wood preservative products and terminate certain uses of other CCA products (68 FR 17366; April 9, 2003). These changes, when fully implemented, might affect the toxicity of discharged stormwater; however, they will not have any direct impact on dioxin or PACs releases resulting from the use of pentachlorophenol and creosote wood preservatives.

5.4.6.6 Stakeholder and EPA Regional Issues

Stakeholders believe that EPA should amend the definition of process wastewater in 40 CFR Part 429 to exclude wastewater generated in air pollution control devices and in operation and maintenance activities. The final rule for the Plywood and Composite Wood Products Manufacture National Emission Standards for Hazardous Air Pollutants (NESHAP) was published on July 30, 2004 (see <http://www.epa.gov/ttn/atw/plypart/plywoodpg.html> and 69

FR 45944). These new standards are based, in part, on the use of wet electrostatic precipitators (WESP), a form of wet air pollution control. In addition to promulgating the new air pollution regulation, EPA also amended the ELGS for the Timber Products Processing Point Source Category codified at 40 CFR Part 429, Subpart B (Veneer Subcategory), Subpart C (Plywood Subcategory), Subpart D (Dry Process Hardboard Subcategory), and Subpart M (Particleboard Manufacturing Subcategory). The amendments adjusted the definition of process wastewater found at 40 CFR Part 429.11(c) to exclude certain sources of wastewater generated by air pollution control devices expected to be installed to comply with the final Plywood and Composite Wood Products NESHAP.

EPA estimated that the nationwide increase in wastewater flow as a result of the amendment is within the range of water flow rates currently handled by individual facilities. EPA believes that facilities would likely dispose of this wastewater by sending it to a municipal treatment facility, reusing it on site (e.g., in log vats or resin mix), or hauling it off site for spray irrigation.

In addition, Washington State permitting authorities suggest revising these guidelines to include effluent limits for stormwater discharges from associated log yards. The state has prepared a manual for implementing industrial stormwater general permits at log yards (7).

EPA will need considerably more data and information to promulgate new effluent guidelines affecting Subparts B, C, D, and M of 40 CFR Part 429 for air pollution control device wastewaters generated in complying with the final NESHAP for Plywood and Composite Wood Products Manufacture. In particular, EPA will need information to adequately characterize the quantity and quality of wastewater that would be generated as result of compliance with the standards. The volume and pollutant content of wastewater generated at these facilities are related to production processes, air pollution control equipment that generate wastewater, the extent of opportunities for internal recycling of wastewater, and the availability of other process uses for wastewater. Until EPA promulgates ELGS for pollutants in these process wastewaters, technology-based effluent limits should be established on a case-by-case basis under 40 CFR Part 125.3. Thus, individual facilities seeking a discharge permit will have the opportunity, on a case-by-case basis, to characterize and obtain discharge allowances for their wastewaters from air pollution control devices installed to comply with the final NESHAP for Plywood and Composite Wood Products Manufacture. The permit writer would be expected to determine, based upon BPJ, the appropriate effluent limitations for these air pollution control wastewaters. (See 40 CFR Part 125.3.) The permit writer can take into account facility-specific information on wastewater volumes and pollutants, available wastewater control and treatment technologies, costs and effluent reduction benefits, receiving water quality, and any applicable State water quality standards.

5.4.6.7 Conclusions

Based on the information for this review, the major toxic discharge associated with timber products processing facilities is stormwater discharges of dioxin and dioxin-like compounds from wood preserving facilities. Stormwater discharges of creosote from wood preserving facilities may also be a significant problem. EPA's conclusions after reviewing this industry are listed below.

- More than 93 percent of the TWPE discharges reported to TRI for 2000 were discharges of dioxin and dioxin-like compounds from SIC code 2491 (wood preserving).
- The majority of the wood preserving facilities report that all dioxin releases derive from stormwater. However, stormwater releases are extremely difficult to estimate because stormwater events are intermittent and vary in intensity. Therefore, the pollutant loads in stormwater releases are uncertain.
- If EPA assumes a toxic-weighting factor for creosote based on its chemical composition, creosote would add 126,000 TWPE to the total TWPE for this industry.
- Based on the information reported to TRI, compared to wood preserving, toxic discharges from other timber products processing SIC codes are low.
- Very little information about discharges of toxic pollutants from this industry is included in PCS.
- Because process wastewater discharge is prohibited, pollutant discharges from most subcategories most likely originate from noncontact cooling water, material storage yard runoff (either raw material or processed wood storage), and boiler blowdown, fire control water, barking, wet storage, or log washing. Of these sources, runoff from preserved wood storage is the most likely source of pollutants.
- Wood preserving facilities are subject to EPA's MSGP or general stormwater permits, unless a permitting authority issues individual NPDES permits for stormwater discharges. MSGP and general stormwater permits require baseline monitoring for arsenic and chromium, but not for constituents of organic wood preservatives, such as PACs, creosote, pentachlorophenol, or dioxins. (Dioxins are potential contaminants of pentachlorophenol.)

- Preservative that is washed off treated wood in storage yards by rainwater is not specifically identified as a RCRA-listed waste and is not subject to RCRA hazardous waste treatment, storage, and disposal regulations unless it exhibits a characteristic hazard (such as toxicity).
- Wood preserving facilities have voluntarily agreed to cancel certain CCA wood preservative products and terminate certain uses of other CCA products (68 FR 17366; April 9, 2003). These changes, however, will not have any direct impact on creosote, PACs, or dioxin releases that are related to the use of pentachlorophenol and creosote wood preservatives.

EPA plans to consider stormwater discharges from wood preserving facilities in the next annual review. In particular, EPA will consider whether these discharges are appropriately controlled through current stormwater discharge permits, whether requirements for these discharges need to be reevaluated, and/or whether it may be appropriate to revise the ELGS to include stormwater discharge requirements.

5.4.6.8 References

1. U.S. EPA. *Preliminary Data Summary for the Wood Preserving Segment of the Timber Products Processing Point Source Category*. EPA-440/1-91/023. Washington, D.C. 1991.
2. U.S. EPA. 1981. *Development Document for Effluent Limitations Guidelines and Standards for the Timber Products Point Source Category*. EPA-440/1-81/023. Washington, D.C. 1981.
3. U.S. EPA. *Development Document for Effluent Limitations Guidelines and New Source Performance Standards for the Plywood, Hardboard, and Wood Preserving Segment of the Timber Products Processing Point Source Category*. EPA-440/1-74-023-a. Washington, D.C. April 1974.
4. 1997 Economic Census Data. Available online at: <http://www.census.gov/epcd/www/econ97.html>
5. U.S. EPA. *1996 Wood Preserving Resource Conservation and Recovery Compliance Guide to Federal Environmental Regulation*. EPA-305-B-96-001. June 1996.
6. Festoso, Shari. Personal communication from NPDES Permit Writer, Alabama Department of Environmental Protection to Betsy Bicknell, ERG. January 2004.
7. Washington State Department of Ecology. *Industrial Stormwater General Permit Implementation Manual for Log Yards*. 04-10-031. April 2004.

5.5 Group IV Industries

This section describes the limited investigations EPA conducted on the Group IV industries. During its screening-level review, EPA did *not* identify this group of industrial point source categories as having high estimates of potential toxic-weighted pollutant discharges. Rather, EPA identified this group of industries based on stakeholder response to public outreach. Therefore, EPA focused this review on the issues identified by stakeholders. In particular, EPA evaluated implementation and efficiency considerations and stakeholder concerns about potential risks to human health and the environment based on available data about discharges from these industries.

5.5.1 **Canned and Preserved Fruits and Vegetables Processing (Part 407)**

During the screening-level review, canned and preserved fruits and vegetable processing was one of eight industrial categories identified solely through Factor 4 concerns. Issues driving the concerns include: 1) discharges of nutrients and conventional pollutants, 2) lack of BOD limits, and 3) improvements in industry capacity to control discharges. In addition, EPA determined that three industrial sectors are unregulated subcategories within Part 407. These sectors, Distilled and Blended Liquors, Malt Beverages, and Soybean Oil Mills, are discussed in Section 5.5.1.7.

5.5.1.1 Industry Description

The Canned and Preserved Fruits and Vegetables Processing Point Source Category is regulated at 40 CFR Part 407. This point source category includes facilities reporting under SIC industry group 203, Canned, Frozen, and Preserved Fruits and Vegetables. Specifically, it includes SIC codes listed below:

- SIC code 2033 - *Canned Fruits, Vegetables, Preserves, Jams, and Jellies*. Establishments primarily engaged in canning fruits, vegetables, and fruit and vegetable juices, and in manufacturing catsup and similar tomato sauces, or natural and imitation preserves, jams, and jellies.
- SIC code 2034 - *Dried and Dehydrated Fruits, Vegetables, and Soup Mixes*. Establishments primarily engaged in sun drying or artificially dehydrating fruits and vegetables, or in manufacturing packaged soup mixes from dehydrated ingredients.
- SIC code 2035 - *Pickled Fruits and Vegetables, Vegetable Sauces and Seasonings, and Salad Dressings*. Establishments primarily engaged in pickling and brining fruits and vegetables, and in manufacturing salad dressings, vegetable relishes, sauces, and seasonings.

- SIC code 2037 - *Frozen Fruits, Fruit Juices, and Vegetables*. Establishments primarily engaged in freezing fruits, fruit juices, and vegetables. These establishments also produce important by-products such as fresh or dried citrus pulp.
- SIC code 2096 - *Potato Chips, Corn Chips, and Similar Snacks*. Establishments primarily engaged in manufacturing potato chips, corn chips, and similar snacks.

Juice manufacturing (covered by SIC codes 2033 and 2037) was identified at a potential subcategory during the Factor 4 analysis.

Facility Counts

EPA obtained information on the number of facilities in the Canned and Preserved Fruits and Vegetables Processing category from three sources: the 1997 U.S. Economic Census, the *TRIReleases2000*, and *PCSLoads2000*. TRI includes facilities reporting discharges to any media. In contrast, the PCS includes only facilities that are permitted for discharge to surface waters. Table 5-89 lists the number of facilities from these sources.

Table 5-89. Number of Facilities in Fruits and Vegetable Processing SIC Codes

SIC Code	1997 U.S. Economic Census	PCS			TRI				
		Total Dischargers	Major Dischargers	Minor Dischargers	Total Reporters	No Reported Discharge	Direct Discharge	Indirect Discharge	Both Direct & Indirect
2033	695	70	8	62	12	11	1	0	0
2034	152	1	0	1	8	5	0	3	0
2035	354	12	2	10	11	7	0	4	0
2037	258	20	7	13	57	42	9	5	1
2096	368	2	1	1	20	14	2	4	0

Source: EPA, *PCSLoads2000*, *TRIReleases2000*.

Of the 40 reporting facilities, 8 are located in Florida. The rest are located in 18 states around the country.

5.5.1.2 Regulatory Background

- Final effluent limitations for Subparts A - E were promulgated March 21, 1974.
- Final effluent limitations for Subparts F, G, and H were promulgated April 16, 1976.

The current ELGs for the Canned and Preserved Fruits and Vegetables Processing Source category, 40 CFR Part 407, contain 8 subcategories (Subparts A - H). Table 5-90 lists the limitations. The technology basis of existing regulations is (BPT) was in-plant waste management and operating methods and end-of-pipe preliminary screening, primary treatment, and secondary biological treatment. BAT and NSPS are the same as BPT followed by disinfection (chlorination). For some facilities, more intensive biological treatment and final multimedia or sand filtration may be required to meet BAT limits. BAT and NSPS limitations are normalized on the basis of metric ton (kkg) of raw material. EPA did not establish pretreatment standards for existing or new indirect dischargers (PSES or PSNS), and reserved NSPS for Subparts F, G, and H.

Table 5-90. Effluent Guidelines for Canned and Preserved Fruits and Vegetables Processing, Part 407

Pollutant	BPT 30-day Averages (kg/kkg)	NSPS 30-day Averages (kg/kkg)
BOD ₅	0.05 to 3.34	0.07 to 0.55
TSS ¹	0.00 to 5.09	0.1 to 0.55
Oil and Grease ²	20 mg/L	none
pH	within the range 6 to 9 ³	within the range 6 to 9 ³

¹BPT TSS limit for "added ingredients" in Subpart H is 0 kg/kkg. NSPS for Subpart H is reserved.

²Oil and grease limits for Subpart H only.

³pH range 6 to 9.5 for Subparts F, G, and H.

5.5.1.3 Wastewater Characteristics and Pollutant Sources

Most major facilities reporting to PCS report discharge outfall flow rates. Table 5-91 presents the total annual flow (in millions of gallons) for 2000, median annual discharge flow, and the range of annual flows for fruits and vegetable processing facilities. Facilities not reporting a flow were not included in the median calculation. Data presented in Table 5-91 are based on major dischargers reporting to PCS for 2000.

Table 5-91. Wastewater Flows in the Canned and Preserved Fruits and Vegetables Processing Industry

SIC Code	Number of Major Discharge Facilities Reporting Nonzero Flows	Median Facility Flow in 2000 (MGY)	Range of Facility Flows (MGY)	Total Flow (MGY)
2033	7	82	15 to 542	1,330
2034	0	-	-	-
2035	2	103	84 to 123	207
2037	7	889	9 to 1510	5,170

Table 5-91 (Continued)

SIC Code	Number of Major Discharge Facilities Reporting Nonzero Flows	Median Facility Flow in 2000 (MGY)	Range of Facility Flows (MGY)	Total Flow (MGY)
2096	1	101	NA	101

Source: EPA, *PCSLoads2000*.

NA – No range was calculated; only 1 facility reported nonzero flow.

Fruit and vegetable processing is seasonal for most producers. Water use and wastewater pollutant loads vary according to the specific raw material processes (e.g., 2,400 gal/ton apples to 17,000 gal/ton cauliflower). Total pollutant loads are directly correlated to the amount of water used in processing, and consequently, water conservation practices can reduce pollutant loads. Most processors use secondary (biological) treatment.

Table 5-92 presents sources of process wastewater in this category.

Table 5-92. Sources of Process Wastewater in Canned and Preserved Fruits and Vegetables Processing Industry

Process	Wastewater Pollutants
Washing: general cleaning and dirt removal of raw products	Suspended solids including fibers and soil particles; possibly pesticides residues
Grading, stemming, pitting, and seeding	Dissolved organic material (BOD ₅), suspended solids including fibers and soil particles, and possibly pesticides residues
Peeling, steam or lye and washing	Sodium hydroxide (high pH), BOD ₅ , and suspended solids
Blanching (scalding with water or steam)	Dissolved organic material (BOD ₅) and suspended solids
Post-blanching washing and cooling	Dissolved organic material (BOD ₅) and suspended solids
Fluming (conveyance)	Dissolved organic material (BOD ₅) and suspended solids
Filling and packaging, including adding syrup, brine, etc.	Dissolved organic material (BOD ₅), salt, oil and grease (depending on product)
Sanitation and plant clean-up	Dissolved organic material (BOD ₅) and suspended solids, residual disinfectant (e.g., chlorine)

Sources: *Waste Management and Utilization in Food Production and Process*, 1995; *State of the Art Report*, 2004; *Clean Technologies in U.S. Industries: Food Processing*, 2004.

Pollutants Discharged

Table 5-93 lists the pollutants reported to PCS for fruit and vegetable processing facilities that reported discharges to PCS by major dischargers in 2000. In addition, this table also lists the pollutants reported to TRI as discharged directly or for fruit and vegetable processing facilities that reported to TRI for 2000. This table lists the number of facilities that

reported each chemical and the total pounds of chemical discharged to surface waters. Indirect discharging facilities reported transfers to POTWs. Using average POTW removal efficiencies, EPA estimated the amount of pollutant discharged to surface water (see DCN 00618, *Evaluation of RSEI Model Runs*, for more information). Therefore, the TWPE estimates in this table have been adjusted to account for POTW treatment

Table 5-93. Pollutant Discharges Reported to PCS and TRI

Pollutant Category & Primary Pollutants	PCS Pounds/yr	PCS TWPE/yr	TRI All Discharge lbs Pounds/yr	TRI All TWPE/yr
All Pollutants	16,020,109	2,905	7,713,669	17,674
Nonconventional	14,614,715	2,638	7,713,699	17,674
Total Dissolved Solids	7,603,747	0	0	0
Total Sulfide	764	2,140	0	0
Ammonia as Nitrogen	73,127	134	21,022	32
Chlorine, Total Residual	261	127	35,253	17,167
Chloride	4,137,463	101	0	0
Nitrogen, Nitrate Total (As N)	1,422,715	88	7,657,242	475
Conventional	1,404,936	NA	0	NA
Total Suspended Solids	990,347	–		
BOD ₅	368,122	–		
Oil and Grease	46,467	–		
Priority	457	267	0	0
Arsenic	34	117		
Copper	119	74		
Selenium	34	38		

Source: EPA, *PCSLoads2000* and *TRIRelases2000*.

NA - EPA does not have TWFs for conventional pollutants, therefore, it did not calculate TWPE for conventional pollutants.

Relative to other industries evaluated, TWPE discharges in the *PCSLoads2000* and *TRIRelases2000* are low. Generally, a few facilities reporting to TRI and PCS contribute most of the TWPE in this industry. For purposes of comparison, Tables 5-94 and 5-95 list the TWPE for fruit and vegetable processing plants along with the industries reporting the highest discharges in each database. Table 5-94 presents the information reported to PCS and Table 5-95 presents the information reported to TRI. (Note: These tables include TWPE loading estimates for the three potential additional subcategories – distilled and blended liquors, malt beverages, and soybean oil mills. No other tables in this subsection reflect facilities or discharges in these subcategories.) For a description of the derivation of the values in these tables, see the memorandum in the public docket *Description and Results of EPA Methodology to Synthesize Screening Level Results for the Effluent Guidelines Program Plan for 2004*, which is available through E-docket, document number OW-2003-0074-0391.

Table 5-94. Canned and Preserved Fruits and Vegetables Processing TWPE Reported to PCS Compared to Industries Reporting Highest Discharge

40 CFR Part	Point Source Category	PCS-Reported TWPE/yr	PCS Rank
423	Steam Electric Power Generation	2,933,209	1
414	Organic Chemicals, Plastics and Synthetic Fibers	1,805,928	2
422	Phosphate Manufacturing	1,095,321	3
415	Inorganic Chemicals Manufacturing	853,568	4
421	Nonferrous Metals Manufacturing	434,925	5
440	Ore Mining and Dressing	383,560	6
410	Textile Mills	296,601	7
419	Petroleum Refining	198,251	8
455	Pesticide Chemicals Manufacturing, Formulating	178,977	9
418	Fertilizer Manufacturing	116,464	10
407	Canned and Preserved Fruits and Vegetables Processing	28,779¹	16

¹ Includes TWPE loading estimates for three potential additional subcategories as described in Section 5.5.1.7.

Table 5-95. Canned and Preserved Fruits and Vegetables Processing TWPE Reported to TRI Compared to Industries Reporting Highest Discharges

40 CFR Part	Point Source Category	TRI Reported TWPE/yr	TRI Rank
414	Organic Chemicals, Plastics and Synthetic Fibers	7,303,782	1
423	Steam Electric Power Generation	1,856,645	2
421	Nonferrous Metals Manufacturing	978,450	3
430	Pulp, Paper and Paperboard (Phase II)	628,785	4
415	Inorganic Chemicals Manufacturing	624,250	5
429	Timber Products Processing	404,926	6
419	Petroleum Refining	385,347	7
455	Pesticide Chemicals Manufacturing, Formulating	324,393	8
428	Rubber Manufacturing	166,343	9
463	Plastic Molding and Forming	106,189	10
407	Canned and Preserved Fruits and Vegetables Processing	38,338¹	17

¹ Includes TWPE loading estimates for three potential additional subcategories as described in Section 5.5.1.7.

5.5.1.4 Treatment Technology and Pollution Prevention

Standard treatment in this industry is biological treatment with primary solids removal, oil and grease removal, and neutralization (pH adjustment) depending on products. Treatment systems must be sufficiently robust to handle seasonal variations in pollutant loads.

Direct discharging plants may disinfect wastewater with chlorine prior to discharge. Advanced treatment would replace chlorine disinfection with ozone or ultraviolet light.

Most advances in reducing pollutant discharges involve water conservation and other pollution prevention practices listed in Table 5-96.

Table 5-96. Water Conservation and Pollution Prevention Alternatives

Process	Water Conservation and Pollution Prevention Alternatives
Washing: general cleaning and dirt removal of raw products	<ul style="list-style-type: none"> • Perform washing and cleaning at the agricultural site, so wastes are reused at the farm. • Use air flotation to remove suspended debris from raw crop materials. • Minimize water use.
Grading, stemming, pitting, and seeding	<ul style="list-style-type: none"> • Minimize water use.
Peeling, steam or lye and washing	<ul style="list-style-type: none"> • Use dry peeling methods.
Blanching (scalding with water or steam)	<ul style="list-style-type: none"> • Use steam blanching rather than water blanching. • Replace blanching with nonthermal means of destroying microbes.
Post-blanching washing and cooling	<ul style="list-style-type: none"> • Use air cooling. • Reuse relatively clean cooling water for peeling, primary washing, or post-peeling washing.
Fluming (conveyance)	<ul style="list-style-type: none"> • Replace water flumes with pneumatic (air-based) transport. • Reuse relatively clean fluming water for peeling, primary washing, or post-peeling washing.
Filling and packaging, including adding syrup, brine, etc.	<ul style="list-style-type: none"> • Minimize water use.
Sanitation and plant clean-up	<ul style="list-style-type: none"> • Use low-volume/high-pressure cleaning systems.

Sources: *Waste Management and Utilization in Food Production and Process*, 1995; *State of the Art Report*, 2004; *Clean Technologies in U.S. Industries: Food Processing*, 2004.

5.5.1.5 Industry Trends

Table 5-97 presents the change in the number of fruit and vegetable processing facilities between 1992 and 1997 by SIC code. The table also shows the difference in the value of goods shipped during this period. Depending on sector, the value of goods shipped has

declined by as much as 10 percent or increased by as much as 28 percent. Table 5-98 presents similar data for facilities in NAICS code 311 (food manufacturing including grains, fruits and vegetables, dairy, meats, seafood, and miscellaneous food) and shows a very small increase in the number of establishments (less than 1 percent) and an 8-percent increase in the value of shipments (not adjusted for inflation).

Table 5-97. Comparison of 1992 and 1997 Census Data

SIC	Industry Sector	Number of Establishments			Value of Goods Shipped (millions of dollars)		
		1997	1992	Percent Change	1997	1992	Percent Change
2033	Canned Fruits, Vegetables Preserves, Jams, and Jellies	695	683	1.8	14.5	15.0	-3.7
2034	Dried and Dehydrated Fruits, Vegetables, and Soup Mixes	152	159	-1.9	2.9	2.8	1.3
2035	Pickled Fruits & Vegetables, Vegetable Sauces & Seasonings, and Salad Dressings	354	377	-6.1	7.1	7.8	-9.6
2037	Frozen Fruits, Fruit Juices, and Vegetables	258	255	1.2	9.6	7.5	27.9
2096	Potato Chips, Corn Chips, and Similar Snacks	368	408	-9.8	9.1	7.3	25.6

Source: 1997 U.S. Economic Census and 1992 U.S. Census Data.

Table 5-98. Comparison of 1997 and 2002 U.S. Economic Census Data

NAICS	Industry Segment	Number of Establishments			Value of Goods Shipped (billions of dollars)		
		2002	1997	Percent Change	2002	1997	Percent Change
311	Food Manufacturing	26,374	26,302	0.27	457	422	8.4

Source: 2002 U.S. Economic Census and 1997 U.S. Economic Census.

5.5.1.6 Stakeholder and EPA Regional Issues

This subsection discusses stakeholder and EPA Regional staff issues. EPA primarily received input from stakeholders prior to publication of the Preliminary Effluent Guidelines Plan. EPA did not receive any comments on the Preliminary Plan pertaining to the existing ELGs for the canned and preserved fruits and vegetables processing industry.

Concerns Identified Pre-Proposal

In the process of conducting its 2003 annual review, EPA solicited input from stakeholders (EPA Regions and industry) on the regulatory status of this industry. Stakeholder suggestions are summarized below.

Previous Suggestions (Section 2.4 of the “Factor 4 Analysis: Implementation and Efficiency Considerations - Status of Screening-Level Review Phase” (Eocket OW-2003-0074-0329))

In general, responders were concerned with the discharge of nutrients, as well as overloading POTWs and small streams (for direct dischargers) with conventional pollutants such as BOD. Responders identified several specific industries as having such characteristics, including vegetables processing. Another issue identified was nonapproved pretreatment processes in relation to juice manufacturing.

Permitting Authorities (Section 2.5 of the “Factor 4 Analysis: Implementation and Efficiency Considerations - Status of Screening-Level Review Phase” (Eocket OW-2003-0074-0329))

Washington State permitting authorities suggest updating these guidelines for both direct and indirect dischargers. Direct dischargers are performing well below the limits, and permitting authorities have found it difficult to address that gap effectively and lower discharges. In addition, permitting authorities suggest that revising these guidelines could address dissolved oxygen problems, since there are no water quality criteria for BOD and no equitable way to determine the far-field impacts of BOD.

Additional Concerns Identified Post-Proposal

One EPA Regional stakeholder noted that POTWs would also benefit from more EPA assistance in managing wastewater with high pollutant loads (BOD, TSS, ammonia). EPA lists these among the 15 pollutants of concern in the new Local Limits Guidance Manual; however, conventional pollutant management is not integrated into many aspects of this manual. In addition, an update of the 1971 document *Equitable Recovery of Industrial Waste Treatment Costs* could be helpful to POTWs needing to manage their capacity and recover the costs for users with high pollutant loads and users whose flows and loadings tend to spike.

EPA appreciates all comments and suggestions provided by the stakeholders and EPA Regional staff. However, as with any comments it receives, EPA cannot address these suggestions without adequate supporting data. Some stakeholders identified nutrient discharges from fruit and vegetable processing plants as a concern. Information in PCS and TRI does not indicate that fruit and vegetable processing plants discharge significant quantities of nutrients relative to other industrial categories. State permitting authorities also suggested that EPA should revise the existing guidelines because dischargers are performing well below the limits.

Because TRI and PCS data indicate toxic discharges from fruit and vegetable processing plants are small relative to other industries, EPA has concluded that a revision would provide only small incremental gains, if any. If stakeholders provide additional data and supporting information on these or any of the issues identified above, EPA will reevaluate them at that time.

5.5.1.7 Potential Additional Subcategories

Based on comments and information received by stakeholders, EPA also evaluated whether it should consider additional subcategories of the Canned and Preserved Fruits and Vegetables Processing category for Distilled and Blended Liquors, SIC code 2085; Malt Beverages, SIC code 2082; and Soybean Oil Mills, SIC code 2075. EPA determined it was appropriate to consider these industrial operations as potential additional subcategories of Part 407.

Distilled and Blended Liquors

One of the industries identified by commenters for new effluent guidelines development is distilled and blended liquors (SIC code 2085), which applies to: establishments primarily engaged in manufacturing alcoholic liquors by distillation, and in manufacturing cordials and alcoholic cocktails by blending processes or by mixing liquors and other ingredients. Establishments primarily engaged in manufacturing industrial alcohol are classified in SIC code 2869, and those only bottling purchased liquors are classified in Wholesale Trade, SIC code 5182. (See SIC Manual, 1987 for a list of specific products included in SIC code 2085).

EPA reviewed the applicability of existing ELGs to determine if discharges from distilled and blended liquor operations were already subject to existing ELGs. In particular, EPA considered Canned and Preserved Fruits and Vegetables Processing (40 CFR Part 470). EPA found that none of the existing categories of Canned and Preserved Fruits and Vegetables Processing apply to discharges from SIC code 2085.

Next, EPA evaluated whether this industrial activity should be addressed as a potential new subcategory under Canned and Preserved Fruits and Vegetables Processing (40 CFR Part 407). Part 407 applies to the processing of a variety of raw fruits and vegetables into fruit and vegetable products. EPA compared the processes, operations, wastewaters, and pollutants addressed by the Canned and Preserved Fruits and Vegetables Processing ELG to the processes, operations, wastewaters, and pollutants of the potential new subcategory.

The basic unit processes employed in producing distilled and blended liquors include milling of grain and malt (soaked and germinated grain); cooking; cooling; filtration; fermenting; distillation; aging; vessel clean up, and packaging. Cordials and liqueurs are manufactured by blending liquors with other ingredients, such as fruit syrups. The grain processing, cooking, filtration, clean-up, and packaging operations at distilled liquors plants are similar to preserved fruit and vegetable operations. Wastewater pollutants from distilled and blended liquors include BOD₅, and suspended solids. (1, Table 50), which are also pollutants

found in wastewaters from fruit and vegetable processing. Molasses distillery wastes include nitrogen and phosphates (1, Table 52). In addition, distilled and blended liquor plants and fruit and vegetable processing plants employ the same type of wastewater treatment: conventional biological treatment.

As a result of this review, EPA concluded the processes, operations, wastewaters, and pollutants at distilled and blended liquor plants are similar to those at fruit and vegetable processing plants.

Based on information in the 1997 Economic Census, EPA estimates there are 60 distilled and blended liquor facilities in the United States. EPA's primary source of wastewater data for this industry is information reported to TRI and PCS for the year 2000. Three facilities reported information to TRI in 2000. Of these, two are zero dischargers and one is a direct discharger. The total toxic pounds reported by the direct discharger in 2000 was 78 TWPE, mostly attributed to chlorine. Twenty-seven facilities reported direct discharges to PCS in 2000. Of these, 7 were major dischargers and 20 were minor dischargers. Detailed discharge information in PCS indicates that the total toxic pounds discharged by the seven major dischargers were 94 TWPE. Therefore, based on the information available at this time, EPA has concluded that it is not appropriate to revise the ELGs for canned and preserved fruits and vegetables processing to include limits for this additional subcategory (distilled and blended liquors) because discharges from this potential subcategory rank low in terms of TWPE.

Malt Beverages

One of the industries identified by commenters for effluent guidelines development is malt beverages (SIC code 2082). SIC code 2082 applies to establishments primarily engaged in manufacturing malt beverages.

EPA reviewed the applicability of existing ELGs to determine if discharges from malt beverages operations were already subject to existing ELGs. In particular, EPA considered Canned and Preserved Fruits and Vegetables Processing (40 CFR Part 70). EPA found that none of the existing subcategories in 40 CFR Part 70 apply to discharges from SIC code 2082.

Next, EPA evaluated whether this industrial activity should be addressed as a potential new subcategory under the Canned and Preserved Fruits and Vegetables Processing (40 CFR Part 407) category. Part 407 applies to the processing of a variety of raw fruits and vegetables into fruit and vegetable products. EPA compared the processes, operations, wastewaters, and pollutants addressed by Canned and Preserved Fruits and Vegetables Processing ELG to the processes, operations, wastewaters, and pollutants of the potential new subcategory.

The basic unit processes used in the malt beverage industry are grinding of rice, corn, and malt (soaked and germinated grain); brewing (cooking); filtration; fermenting; aging; vessel clean-up, and packaging. The grain processing, cooking, filtration, and packaging

operations at malt beverage plants are similar to preserved fruit and vegetable operations. Wastewater pollutants from this industry include BOD₅ and suspended solids. (1, Tables 33 and 35), which are also pollutants found in wastewaters from fruit and vegetable processing. In addition, malt beverages processing plants employ the same type of wastewater treatment as fruit and vegetable processing plants: conventional biological treatment. Spent grain (mash) is typically recovered for use as animal feed.

As a result of this review, EPA concluded the processes, operations, wastewaters, and pollutants at malt beverage plants are similar to those at fruit and vegetable processing plants. Malt beverages are appropriately considered as a potential new subcategory of 40 CFR Part 407.

Based on information in the 1997 Economic Census, EPA estimates there are 529 malt beverage facilities in the United States. As EPA's primary source of wastewater data for this industry is information reported to TRI and PCS for the year 2000. Twenty-seven malt beverage facilities reported information to TRI in 2000. Of these, 13 were indirect dischargers, 5 were direct dischargers, and 9 were zero dischargers. The total toxic pounds reported by all malt beverage facilities in TRI was 7,594 TWPE with one indirect discharger contributing 97 percent of the TWPE from sodium nitrite. Eleven facilities reported direct discharges to PCS in 2000. Of these, four were major dischargers and seven were minor dischargers. Detailed discharge information for the four major dischargers in PCS indicates that the total toxic pounds discharged by these facilities was 25,781 TWPE. One facility contributed 97 percent of the TWPE from chlorine. Based on the information in TRI and PCS, EPA concludes that, with a few exceptions, discharges from malt beverage facilities rank low in terms of toxic pounds discharged. As a result, EPA has concluded that it is not appropriate to revise the ELGs for canned and preserved fruits and vegetables processing to include limits for this additional subcategory because only a few facilities contribute the bulk of the TWPE for this industry.

Soybean Oil Mills

One of the industries identified by commenters for effluent guidelines development is soybean oil mills (SIC code 2075). The SIC code 075 applies to establishments primarily engaged in manufacturing soybean oil, cake, and meal, and soybean protein isolates and concentrates, or in processing purchased soybean oil other than into edible cooking oils. Establishments primarily engaged in refining soybean oil into edible cooking oils are classified in SIC code 2079.

EPA reviewed the applicability of existing ELGs to determine if discharges from soybean oil mill operations were already subject to existing ELGs. In particular, EPA reviewed the applicability of Canned and Preserved Fruits and Vegetables Processing (40 CFR Part 407) to these operations. EPA found that none of the current subcategories of Canned and Preserved Fruits and Vegetables Processing apply to discharges from SIC code 2079.

Next, EPA evaluated whether this industrial category should be addressed as a potential new subcategory under Canned and Preserved Fruits and Vegetables Processing (40 CFR 407). Part 407 applies to the processing of a variety of raw fruits and vegetables into fruit and vegetable products. EPA compared the processes, operations, wastewaters, and pollutants addressed by Canned and Preserved Fruits and Vegetables Processing to the processes, operations, wastewaters, and pollutants of the potential new subcategory.

At soybean oil mills, a vegetable (raw soybeans) is processed into soybean products. Soybeans are dehulled, cooked and flaked, then crushed and subjected to direct solvent extraction to produce two types of products, soybean oil and soybean meal and cakes. Solvent is removed from the meal by steam (vapor) stripping followed by toasting. Solvent is recovered from the oil by evaporation followed by steam stripping. The dehulling, cooking, flaking, toasting, and clean-up operations at soybean oil mills are similar to preserved fruit and vegetable processing operations. Wastewater pollutants from this industry include BOD, suspended solids, and fats, oils, and greases (1, Table 18), which are also pollutants found in wastewaters from fruit and vegetable processing. In addition, soybean oil mills and fruit and vegetable processing plants employ the same type of wastewater treatment: conventional biological treatment preceded by oil/water separation of high oil concentration wastewaters.

As a result of this review, EPA concluded the processes, operations, wastewaters, and pollutants at soybean oil mills are similar to those at fruit and vegetable processing plants. Soybean Oil Mills is appropriately considered an a potential new subcategory of 40 CFR Part 407.

Based on information in the 1997 economic census, EPA estimates there are 118 soybean oil mills in the United States. EPA's primary source of wastewater data for this industry is information reported to TRI and PCS for the year 2000. Sixty-five soybean oil mills reported information to TRI in 2000. Of these, 42 were indirect dischargers, 6 were direct dischargers, 4 were both indirect and direct dischargers, and 13 were zero dischargers. The total toxic pounds reported by all malt beverage facilities in TRI was 12,991 TWPE, with two direct discharging facility contributing 98 percent of the TWPE from sodium nitrite and chlorine. Nineteen facilities reported direct discharges to PCS in 2000. Of these, one was a major discharger and the remainder were minor discharges. Detailed discharge information for the single major dischargers indicates that the facility's permit includes only limitations for conventional pollutants. Therefore, the TWPE estimate from the PCS facilities is 0 TWPE. Based on the information in TRI and PCS, EPA concludes that, with a few exceptions, discharges from soybean oil mills rank low in terms of toxic pounds discharged. As a result, EPA has concluded that it is not appropriate to revise the ELGs for canned and preserved fruits and vegetables processing to include limits for this additional subcategory because only a few facilities contribute the bulk of the TWPE for this industry.

5.5.1.8 Conclusions

Based on information reported to TRI and PCS, toxic discharges from fruits and vegetable processing plants are low relative to other industrial categories. In addition, only a few facilities generally are the main contributors to the TWPE for this industry. The pollutants driving the TWPE estimate for these few facilities are total residual chlorine and total sulfide.

Stakeholders and EPA Regional staff identified various issues associated with discharges from fruit and vegetable processing plants. At this time, the information in the docket for this annual review does not support the concerns raised. In the event that stakeholders provide additional data and supporting information during subsequent review cycles, EPA will reevaluate them at that time.

In this review, EPA also evaluated whether it should consider developing limitations and standards for additional subcategories for Distilled and Blended Liquors, SIC code 2085; Malt Beverages, SIC code 2082; and Soybean Oil Mills, SIC code 2075. EPA concluded that it is not appropriate to revised the ELG for Canned and Preserved Fruits and Vegetables Processing category to include limits for these additional subcategories because only a few facilities contribute the bulk of the TWPE and/or discharges rank low relative to other industrial categories.

5.5.1.9 References

1. Environmental Science and Engineering. *Draft Development Document for Effluent Limitations Guidelines and New Source Performance Standards for the Miscellaneous Foods and Beverages Point Source Category*. Prepared for U.S. EPA Effluent Guidelines Division. 1975.

5.5.2 Canned and Preserved Seafood Processing (Part 408)

During the screening-level review phase, the Canned and Preserved Seafood Processing Point Source Category was one of eight industrial categories identified solely through Factor 4 concerns. Issues driving the concerns include: 1) discharges of nutrients and conventional pollutants resulting in overloading POTWs and small streams; 2) no limits for pollutants such as nutrients and pathogens, now causing concern; and 3) changes in control technologies since the promulgation of the guidelines.

5.5.2.1 Industry Description

The Canned and Preserved Seafood Processing category is regulated at 40 CFR Part 408. This category includes facilities reporting under SIC industry group 20, Food and Kindred Products. Specifically, it includes SIC code 2091, Canned and Cured Fish and Seafoods, and SIC code 2092, Prepared Fresh or Frozen Fish and Seafoods. EPA identified no specific subcategories during the Factor 4 analysis; however, follow-up discussions identified

about 150 companies, primarily in Washington and Alaska that are categorized under SIC code 2091, and just under 600 companies categorized under SIC code 2092.

- SIC code 2091 - *Canned and Cured Fish and Seafoods*. Establishments primarily engaged in cooking and canning fish, shrimp, oysters, clams, crabs, and other seafoods, including soups, and those engaged in smoking, salting, drying, or otherwise curing fish and other seafoods for the trade.
- SIC code 2092 - *Prepared Fresh or Frozen Fish and Seafoods*. Establishments primarily engaged in preparing fresh and raw or cooked frozen fish and other seafoods and seafood preparations, such as soups, stews, chowders, fishcakes, crabcakes, and shrimp cakes. Prepared fresh fish are eviscerated or processed by removal of heads, fins, or scales. This industry also includes establishments primarily engaged in the shucking and packing of fresh oysters in nonsealed containers.

EPA obtained information on the number of facilities in this category from three sources: the 1997 U.S. Economic Census, *TRIReleases2000*, and *PCSLoads2000*. TRI includes facilities reporting discharges to any media. In contrast, PCS includes only facilities that are permitted for discharge to surface waters. Table 5-99 lists the number of facilities from these sources.

Table 5-99. Number of Facilities in the Canned and Preserved Seafood Processing Category

SIC	U.S. Economic 1997 Census	PCS			TRI				
		Total	Major Dischargers	Minor Dischargers	Total Reporting	No Reported Discharge	Direct Discharge	Indirect Discharge	Both Direct & Indirect
2091	163	19	5	14	5	5	0	0	0
2092	669	70	3	67	5	3	2	0	0

Source: EPA, *PCSLoads2000*, *TRIReleases2000*.

Of the seven facilities reporting discharges to PCS or TRI, three are located in Alaska. The others are located in Mississippi, Ohio, Rhode Island, and Puerto Rico.

5.5.2.2 Regulatory Background

EPA promulgated ELGS for BPT, BAT, and NSPS for the catfish, crab, shrimp, and tuna segments of the industry (Subparts A-N) in 1974.

EPA promulgated ELGS for BPT, BAT, and NSPS for the fish meal, bottom fish, clam, oyster, sardine, scallop, herring, and abalone segments of the industry (Subparts O-AG) in 1975.

The current ELGS for the Canned and Preserved Seafood Processing category, 40 CFR Part 408 (listed in Table 5-100), contain 33 subcategories (Subpart A - AG). EPA established limitations only for the BOD, TSS, and oil and grease. The technology basis for existing effluent guidelines includes screening, dissolved air flotation, and biological treatment.

Coliform Test as Indicator

EPA considered including a coliform test as an indicator of fecal content in seafood processing wastewater (1, pg 213). Coliform organisms, however, are not naturally found in the intestines of cold-blooded animals. Therefore, no correlation exists between fish fecal contamination and fecal coliform levels in fish processing wastewater. An EPA-sponsored study of fecal coliform levels in fish processing wastewater conducted in 1973 concluded that the coliform test produced extremely inconsistent results. Based on the results of the study, EPA decided not to include fecal coliform in the list of parameters selected for regulation.

Kjeldahl Test for Monitoring Nitrogen

EPA considered including a kjeldahl test for monitoring organic nitrogen and ammonia levels in fish processing wastewater. EPA did not include a monitoring requirement for total kjeldahl nitrogen (TKN) because the removal of nitrogen in physical/chemical and biological treatment had yet to be evaluated. Furthermore, there was no demonstrated need for a separate treatment technology specific to nitrogen compounds.

5.5.2.3 Wastewater Characteristics and Pollutant Sources

Most major facilities reporting to PCS report discharge outfall flow rates. Table 5-101 presents the total annual flow (in millions of gallons) for 2000, median annual discharge flow, and the range of annual flows for seafood processing facilities. Facilities not reporting a flow were not included in the median calculation. Data presented in Table 5-101 are based on major dischargers reporting to PCS for 2000.

Table 5-101. Wastewater Flows

SIC Code	Number of Major Facilities Reporting Nonzero Flows	Median Facility Flow 2000 (MGY)	Range of Facility Flows 2000 (MGY)	Total Flow 2000 (MGY)
2091	4	736	523 - 1679	3,674
2092	2	518	31 - 1006	1,036

Source: EPA, *PCSLoads2000*.

Wastewater is high in solids, dissolved proteins, BOD, oil and grease, organic nitrogen, and ammonia. Wastewater sources in seafood processing include thawing, butchering, washing, peeling, picking, meat flumes, separators, cooking, and cleaning. Wastes generally include carcasses, shells, trimmings, and by-catch not suitable for human consumption.

Table 5-100. Effluent Guidelines for Canned and Preserved Seafood Processing Part 408

Subparts	BOD ₅ - 30-Day Average (kg/kkg)			TSS - 30-Day Average (kg/kkg)			Oil and Grease - 30-Day Average (kg/kkg)		
	BPT	BAT	NSPS	BPT	BAT	NSPS	BPT	BAT	NSPS
Farm-raised catfish: A	NA	2.3	2.3	9.2	5.7	5.7	3.4	0.45	0.45
Crab: B, C, D, F, H	NA	0.15 to 2.5	2.5 to 4.1 ¹	0.74 to 12	0.23 to 6.3	0.45 to 6.3	0.20 to 4.2	0.045 to 1.3	0.065 to 1.3
Remote Alaskan crab: E, G	NA	NA	NA	-- ²	3.3 to 5.3	3.3 to 5.3	-- ²	0.36 to 0.52	0.36 to 0.52
Shrimp: I, K, L, M	NA	10 to 28	25 to 62 ¹	38 to 210	3.4 to 18	10 to 180	12 to 17	1.0 to 3.8	1.5 to 15
Remote Alaskan shrimp: J	NA	NA	NA	-- ²	180	180	-- ²	15	15
Tuna: N	9.0	0.62	8.1	3.3	0.62	3.0	0.84	0.077	0.76
Fish meal: O	3.5	2.6	2.9	1.3	1.3	1.3	0.63	0.63	0.63
Salmon: P, Q (nonremote), R, S	NA	1.0 to 13 ³	1.4 to 32 ¹	1.4 to 22	0.12 to 2.2	0.37 to 21	0.17 to 10	0.018 to 1.0	0.023 to 10
Remote Alaskan salmon: Q	-- ²	NA	-- ²	-- ²	21	-- ²	-- ²	10	-- ²
Bottom fish: T, U, V	NA	0.58 to 5.3 ³	0.58 to 7.4 ¹	2.1 to 14	0.73 to 1.1	0.73 to 2.5	0.55 to 5.7	0.03 to 0.34	0.03 to 0.39
Clam: W, X	NA	5.7 ³	5.7 ¹	15 to 18	4.4 to 17	4.4 to 17	0.23 to 0.97	0.092 to 0.21	0.092 to 0.21
Oyster: Y, Z, AA	NA	17 ³	17 ¹	15 to 190	15 to 39	15 to 39	0.70 to 1.7	0.42 to 1.6	0.42 to 1.6
Sardine: AB	NA	NA	NA	10 to 16	10	10	1.4 to 2.8	5.2	0.57
Scallop: AC, AD	NA	NA	NA	1.4	1.4	1.4	0.24	0.23	0.23
Herring filet: AE (nonremote), AF	NA	6.2 ³	15 ¹	24	1.8	5.2 to 18	10	0.73	1.1 to 7.3
Alaskan herring filets (remote): AE	-- ²	NA	-- ²	-- ²	18	-- ²	-- ²	7.3	-- ²
Alabone: AG	NA	NA	NA	15	14	14	1.4	1.3	1.3

Sources: EPA, *Technical Development Documents*, 1974 and 1975.

NA - no limitations were established.

¹There are no NSPS for BOD for Subparts D, F, I, P, Q, T, W, Y, Z, and AE.

²No pollutants exceeding 1.27cm in any dimension may be discharged.

³There are no BAT limits for BOD for Subparts P, T, W, Y, and Z.

Pollutants Discharged

Table 5-102 lists the pollutant discharges reported to PCS and TRI in 2000 for seafood processing facilities. This table lists the number of facilities that reported each chemical and the total pounds of chemical discharged to surface waters. Indirect discharging facilities reported transfers to POTWs. Using average POTW removal efficiencies, EPA estimated the amount of pollutant discharged to surface water (see DCN 00618, *Evaluation of RSEI Model Runs*, for more information). Therefore, the TWPE estimates in this table have been adjusted to account for POTW treatment.

Table 5-102. Pollutant Discharges Reported to PCS and TRI in 2000

Pollutant Category and Primary Pollutants	PCS (Pounds/yr)	PCS TWPE/yr	TRI (Pounds/yr)	TRI TWPE/yr
All Pollutants	103,177,359	18,961	53,562	20
Nonconventionals	969,315	18,933	53,562	20
Total Sulfide	6,728	18,842 (100%)	0	0
Ammonia as Nitrogen	4,988	9	11,388	17 (87%)
Nitrogen, Nitrate Total	431,852	27	42,174	3 (13%)
Conventionals	102,207,906	0	0	0
BOD ⁵	48,117,494	–	–	–
TSS	38,672,465	–	–	–
Oil and Grease	15,417,947	–	–	–
Priority	138	28	0	0
Lead	7	17	0	0
Copper	9	6	0	0
Zinc	122	6	0	0

Sources: EPA, *TRIReleases2000* and *PCSLoads2000*.

Relative to other industries evaluated, TWPE discharges in PCS and TRI are low. Sulfide from a single facility contributes almost 99 percent of the overall TWPE discharged from this industry. For comparison purposes, Tables 5-103 and 5-104 present the TWPE for seafood processing along with the industries reporting the highest discharges in each database. Table 5-103 presents the information reported to PCS and Table 5-104 presents the information reported to TRI. For a description of the derivation of the values in these tables, see the memorandum in the public docket titled *Description and Results of EPA Methodology to Synthesize Screening Level Results for the Effluent Guidelines Program Plan for 2004*, which is available through Edoocket at document number OW-2003-0074-0391.

Table 5-103. Canned and Preserved Seafood Processing TWPE Reported to PCS Compared to Industries Reporting 10 Highest Discharges

40 CFR Part	Point Source Category	PCS-Reported TWPE/yr	PCS Rank
423	Steam Electric Power Generation	2,933,209	1
414	Organic Chemicals, Plastics and Synthetic Fibers	1,805,928	2
422	Phosphate Manufacturing	1,095,321	3
415	Inorganic Chemicals Manufacturing	853,568	4
421	Nonferrous Metals Manufacturing	434,925	5
440	Ore Mining and Dressing	383,560	6
410	Textile Mills	296,601	7
419	Petroleum Refining	198,251	8
455	Pesticide Chemicals Manufacturing, Formulating	178,977	9
418	Fertilizer Manufacturing	116,464	10
408	Canned and Preserve Seafood Processing	18,961	20

Source: EPA, *PCSLoads2000*.**Table 5-104. Canned and Preserved Seafood Processing TWPE Reported to TRI Compared to Industries Reporting 10 Highest Dischargers**

40 CFR Part	Point Source Category	TRI-Reported TWPE/yr	TRI Rank
414	Organic Chemicals, Plastics and Synthetic Fibers	7,303,782	1
423	Steam Electric Power Generation	1,856,645	2
421	Nonferrous Metals Manufacturing	978,450	3
430	Pulp, Paper and Paperboard (Phase II)	628,785	4
415	Inorganic Chemicals Manufacturing	624,250	5
429	Timber Products Processing	404,926	6
419	Petroleum Refining	385,347	7
455	Pesticide Chemicals Manufacturing, Formulating	324,393	8
428	Rubber Manufacturing	166,343	9
463	Plastic Molding and Forming	106,189	10
408	Canned and Preserved Seafood Processing	20	42

Source: EPA, *TRIRelases2000*.

5.5.2.4 Treatment Technology and Pollution Prevention

Most processing plants use screening and sedimentation for solids-liquid separation, dissolved air flotation units, and biological treatment. Seafood processing plants also use in-process controls such as water management and by-product/waste recovery.

Pollution prevention efforts focus on reductions in BOD and wastewater management, such as by-product recovery, in-plant controls, and recycling. Increased contact between water and seafood products and wastes is undesirable because it results in higher pollutant loadings and decreases the nutritional value of by-products. Table 5-105 presents water conservation and pollution prevention alternatives for this industry.

Table 5-105. Water Conservation and Pollution Prevention Alternatives

Process	Water Conservation/Pollution Prevention Alternative
Cleaning	<ul style="list-style-type: none"> • Reuse water from “clean” processes in less hygiene-demanding processes, such as cleaning. • Filter, store, and reuse cleaning water.
Recycling	<ul style="list-style-type: none"> • Install heat pump evaporator to reduce BOD concentrations in wastewater to allow for a closed-loop process. Eliminates water discharge.¹
Transportation	<ul style="list-style-type: none"> • Use dry handling in place of flumes for in-plant transport of products. • Use collection hoppers to collect dry waste from butchering and clean up to eliminate waste flumes. • Collect dry wastes using pneumatic brooms or nozzles in place of water.
By-product recovery	<ul style="list-style-type: none"> • Recover protein from wastewater for use as fish meal or animal feed. • Recover solids early from wastewater to lower BOD and nitrogen, and to avoid decomposition of potentially valuable by-products.

Sources: EPA, *Technical Development Documents*, 1974 and 1975; Anderson, Driscoll, Carawan, and Pacific Northwest Pollution Prevention Research Center.

¹The heat pump evaporator was used in a case where a local POTW did not have enough capacity to treat a crabmeat processor’s wastewater, which was high in BOD.

5.5.2.5 Industry Trends

1997 U.S. Economic Census provides data that illustrates the changes in the number of facilities and in the value of goods shipped between 1992 and 1997, as shown in Table 5-106. Table 5-107 presents similar data for facilities in NAICS code 311 (food manufacturing including grains, fruits and vegetables, dairy, meats, seafood, and miscellaneous food) for the years 1997 and 2002. The table shows a very small increase in the number of establishments (less than 1 percent) and an 8-percent increase in the value of shipments (not adjusted for inflation).

Table 5-106. 1992 and 1997 Census Data

SIC	Industry Sector	Number of Establishments			Value of Goods Shipped (millions of dollars)		
		1997	1992	Percent Change	1997	1992	Percent Change
2091	Canned and Cured Fish and Seafoods	163	159	2.5	854	969	-11.9
2092	Prepared Fresh or Frozen Fish and Seafoods	669	685	-2.3	7,039	W	NA

Source: 1997 and 1992 U.S. Economic Census.

W - Data were withheld to avoid disclosure.

NA - Comparable data were not available.

Table 5-107. 1997 and 2002 Census Data

NAICS	Industry Segment	Number of Establishments			Value of Goods Shipped (billions of dollars)		
		2002	1997	Percent Change	2002	1997	Percent Change
311	Food Manufacturing	26,374	26,302	0.27	457	422	8.4

Source: 2002 and 1997 U.S. Economic Census.

5.5.2.6 Stakeholder and EPA Regional Issues

This subsection discusses stakeholder and regional staff issues. EPA primarily received input from stakeholders prior to publication of the Preliminary Plan. EPA did not receive any comments on the Preliminary Plan pertaining to existing ELGS for the seafood processing industry.

Concerns Identified Pre-Proposal

Several stakeholder groups surveyed by the Agency during the 2004 annual review provided input on the Canned and Preserved Seafood Processing category. Each group's suggestions are summarized below.

Previous Suggestions (Section 2.4 of the "Factor 4 Analysis: Implementation and Efficiency Considerations - Status of Screening Level Review Phase" (Edocket OW-2003-0074-0329)

In the fall of 1999 and again in the spring of 2001, EAD requested suggestions from Headquarters, Regional, and state staff charged with the task of implementing ELGS to follow up on concerns and to gather recommendations regarding which effluent guidelines the Agency might develop or revise. Responders identified seafood processing on the basis of

concerns over the discharge of nutrients. They were also concerned about overloading POTWs and small streams (for direct dischargers) with conventional pollutants such as BOD.

Draft Strategy Outreach: Permitting Authorities (Section 2.5 of the “Factor 4 Analysis: Implementation and Efficiency Considerations - Status of Screening Level Review Phase” (Edocket OW-2003-0074-0329))

Upon announcing the draft *Strategy* in 2002, EPA began collecting information from experts in effluent guidelines implementation. This includes management and staff in EPA’s Office of Wastewater Management (OWM). It also includes EPA Regional and state NPDES permit writers, NPDES, pretreatment coordinators, and coordinators for the Total Maximum Daily Load (TMDL) program. These EPA permitting authorities identified concerns for seafood processing guidelines. Issues include the discharge of conventional pollutants BOD and pathogens, especially fecal coliform during seafood processing.

Washington State permitting authorities also noted that the guidelines are out of date (originally promulgated in 1974) and need to be updated. Alaska noted that six of its seven impairments are due to seafood processing, specifically from discharges of residues and resulting dissolved gas concentrations.

Draft Strategy Outreach: AMSA & ASIWPCA (Section 2.6 of the “Factor 4 Analysis: Implementation and Efficiency Considerations - Status of Screening Level Review Phase” (Edocket OW-2003-0074-0329))

Upon announcing the draft *Strategy* in 2002, EPA gathered information from stakeholders in two water pollution control associations: Association of Metropolitan Sewerage Agencies (AMSA) and the Association of State and Interstate Water Pollution Control Authorities (ASIWPCA).

In a teleconference with ASIWPCA members, EPA listed the industrial categories with existing effluent guidelines identified by other stakeholders as possibly warranting revision. In response, ASIWPCA stakeholders made several points. First, seafood processing effluent guidelines do not regulate pollutants now understood to cause problems, such as discharge nutrients and fecal coliform for which there are no limits. Second, the guidelines for this industry are out of date, requiring only screening of the effluent, when the available technology has advanced well beyond this level.

Additional Concerns Identified Post-Proposal

One stakeholder noted that POTWs would also benefit from more EPA assistance in managing wastewater with high pollutant loads (BOD, TSS, ammonia). EPA lists these among the 15 pollutants of concern in the new Local Limits Guidance Manual; however, conventional pollutant management is not integrated into many aspects of this manual. In addition, the pretreatment community should be reminded of the relationship between accepting

wastewater with high BOD levels and meeting ammonia limits. Finally, Alaska seafood processors have not yet converted to recovering by-products for other uses, which could significantly reduce pollutant loadings.

EPA appreciates all comments and suggestions provided by the stakeholders and EPA Regional staff. However, as with any comments it receives, EPA cannot address these suggestions without adequate supporting data. Some stakeholders identified nutrient discharges from seafood processing plants as a concern. Information in PCS and TRI does not indicate that seafood processing plants are discharging significant quantities of nutrients relative to other industrial categories. State permitting authorities also suggested that EPA should revise the existing guidelines to include limitations for fecal coliform. EPA does not generally regulate fecal coliform in ELGS. In the event that stakeholders provide additional data and supporting information, on these or any of the issues identified above, EPA will reevaluate them at that time.

5.5.2.7 Conclusions

Based on information reported to TRI and PCS, toxic discharges from seafood processing plants are low relative to other industrial categories. Sulfide from a single facility contributes almost 99 percent of the overall TWPE for this industry.

Stakeholders and EPA staff identified various issues associated with discharges from seafood processing plants. At this time, the information in the docket for the annual review does not support the concerns raised. In the event that stakeholders provide additional data and supporting information during subsequent review cycles, EPA will reevaluate them at that time.

5.5.2.8 References

1. U.S. EPA. *Development Document for Effluent Limitations Guidelines and Standards of Performance for the Catfish, Crab, Shrimp, and Tuna Segments of the Canned and Preserved Seafood Processing Industry Point Source Category. Phase I.* EPA-440-1-74-020a. Washington, D.C. 1974.
2. U.S. EPA. *Development Document for Effluent Limitations Guidelines and New Source Performance Standards for the Fish Meal, Salmon, Bottom Fish, Clam, Oyster, Sardine, Scallop, Herring, and Abalone Segment of the Canned and Preserved Fish and Seafood Processing Industry Point Source Category: Group I, Phase II.* EPA-440-1-75-041A. Washington, D.C. 1975.

5.5.3 Coal Mining (Part 434)

During the screening-level review phase, coal mining was one of eight industrial categories identified solely through Factor 4 concerns. Issues driving the concerns include: 1) stormwater runoff, 2) high discharges of total dissolved solids (TDS) and total suspended solids (TSS), and 3) manganese discharges.

5.5.3.1 Industry Description

The Coal Mining Point Source Category is regulated at 40 CFR Part 434. This point source category includes facilities reporting under SIC industry group 122, Bituminous Coal and Lignite Mining. Specifically, it includes SIC code 1221, Bituminous Coal and Lignite Surface Mining, and SIC code 1222, Bituminous Coal Underground Mining. No specific subcategories were identified during the Factor 4 analysis. Below is a description of these SIC codes:

- SIC code 1221 - *Bituminous Coal and Lignite Surface Mining*. Establishments primarily engaged in producing bituminous coal or lignite at surface mines or in developing bituminous coal or lignite surface mines. This industry includes auger mining, strip mining, culm bank mining, and other surface mining, by owners or lessees or by establishments which have complete responsibility for operating bituminous coal and lignite surface mines for others on a contract or fee basis. Bituminous coal and lignite preparation plants performing such activities as cleaning, crushing, screening or sizing are included if operated in conjunction with a mine site, or if operated independently of any type of mine.
- SIC code 1222 - *Bituminous Coal Underground Mining*. Establishments primarily engaged in producing bituminous coal in underground mines or in developing bituminous coal underground mines. This industry includes underground mining by owners or lessees or by establishments which have complete responsibility for operating bituminous coal underground mines for others on a contract or fee basis. Bituminous coal preparation plants performing such activities as cleaning, crushing, screening or sizing are included if operated in conjunction with a mine. Independent bituminous coal preparation plants are classified in SIC code 1221.
- SIC code 1231 - *Anthracite Mining*. Establishments primarily engaged in producing anthracite or in developing anthracite mines. All establishments in the United States that are classified in this industry are located in Pennsylvania. This industry includes mining by owners or lessees or by establishments which have complete responsibility for operating anthracite mines for others on a contract or fee basis. Also included are anthracite preparation plants, whether or not operated in conjunction with a mine.

Facility Counts

EPA obtained information on the number of facilities in the Coal Mining category from three sources: the 1997 U.S. Economic Census, *TRIRelases2000*, and *PCSLoads2000*. TRI includes facilities reporting discharges to any media. In contrast, PCS includes only

facilities that are permitted for discharge to surface waters. Table 5-108 lists the number of facilities from these sources.

Table 5-108. Number of Facilities in the Coal Mining Category

SIC	1997 Economic Census	PCS			TRI				
		Total	Major Dischargers	Minor Dischargers	Total	No Reported Discharge	Direct Discharge	Indirect Discharge	Both Direct & Indirect
1221	829	129	15	114	50	33	17	0	0
1222	614	17	1	16	27	22	5	0	0
1231	68	0	0	0	0	0	0	0	0

Source: EPA, PCSLoads2000, TRIRelases2000.

Coal mining facilities are located throughout the United States, with the highest concentration in West Virginia, Alabama, and Ohio.

5.5.3.2 Regulatory Background

Below is a summary of the regulatory background of this industry:

- EPA first promulgated BPT limitations for Subparts B (preparation plants), C (acid drainage mines), and D (alkaline drainage mines) on April 26, 1977;
- EPA promulgated NSPS for Subparts B, C, and D on January 12, 1979, and established subcategories for reclamation and western mines;
- EPA revised BPT and NSPS rainfall exemptions on December 28, 1979; and
- EPA published proposed BAT and NSPS limitations for all subcategories in January 1981 including proposed amendments to BPT.

The current ELGS for the Coal Mining category, 40 CFR Part 434, contain eight subcategories (Subpart A - H). Table 5-109 lists the limitations. The technology basis for these limitations and standards is neutralization and settling. BAT limitations are the same as BPT limitations. In addition, NSPS is identical to BAT, except NSPS requires no discharge of wastewater pollutants from preparation plants (Subpart B). The technology basis for the no-discharge requirement was a complete water recycle system. No limits were established for Subpart H (Western Mines). Rather, operators are required to submit and implement a Sediment Control Plan to maintain sediment discharges at or below premining levels.

Table 5-109. Effluent Guidelines for Coal Mining Part 434

	BPT - 30-day Averages (mg/L)	BPT - Daily Maximum (mg/L)
TSS	35	70
Settleable Solids ¹	0.5 mL/L	
pH	within range of 6 to 9	within range of 6 to 9
Iron, Total	3.5	7.0
Manganese, Total ²	2.0	4.0

Source: US EPA, 1981. *Development Document for Effluent Limitations Guidelines and Standards for the Coal Mining Point Source Category*. 440181057b.

¹Limits for settleable solids only apply to Subpart E (post mining areas).

²No manganese limits exist for Subpart D (alkaline drainage mines).

In addition, Subpart F, Miscellaneous Provisions, contains alternative limitations that apply during catastrophic precipitation events. These limitations, listed in Table 5-110, and apply to discharges that result from a rainfall or snowmelt event less than the 10-year, 24-hour storm. For events greater than the 10 year, 24-hour precipitation event, there are no limitations on settleable solids. The only limitation is that pH remain between 6 and 9.

Table 5-110. Catastrophic Precipitation Event Exemption

	BPT - Daily Maximum
Settleable Solids ¹	0.5 mL/L
pH	within range of 6 to 9

Source: US EPA, 1981. *Development Document for Effluent Limitations Guidelines and Standards for the Coal Mining Point Source Category*, EPA 440-1-81-057b.

¹No limits on settleable solids when precipitation exceeds the 10-year, 24-hour storm.

Other Regulations

In addition to regulating wastewater discharges under the effluent guidelines program, EPA regulates hazardous and solid waste under the RCRA and air emissions under the Clean Air Act (CAA). Other regulating authorities applicable to coal mining include:

- *Department of Labor, Mine Safety and Health Administration (MSHA)*: Responsible for all federally required plans, approvals, certifications, and licensing relating to mine safety.
- *Department of Interior, Office of Surface Mining (OSM)*: Regulates active coal mining operations and supports the reclamation of abandoned mines as required by the Surface Mining Control and Reclamation Act of 1977 (SMCRA).

- *Army Corps of Engineers (COE)*: Responsible for processing permit applications and issuing permits as outlined in Section 404 of the CWA.

5.5.3.3 Wastewater Characteristics and Pollutant Sources

Most major facilities reporting to PCS report discharge outfall flow rates. Table 5-111 presents the total annual flow (in millions of gallons) for 2000, median annual discharge flow, and the range of annual flows for coal mining facilities. Facilities not reporting a flow were not included in the median calculation. Data presented in Table 5-111 are based on major dischargers reporting to PCS for 2000.

Table 5-111. Wastewater Flows for Coal Mining Facilities

SIC Code	Number of Major Facilities Reporting Nonzero Flows	Median Facility Flow in 2000 (MGY)	Range of Facility Flows in 2000 (MGY)	Total Flow in 2000 (MGY)
1221	9	831.21	63 - 6,914	15,676.75
1222	1	526.11	NA	526.11

Source: EPA, *PCSLoads2000*.

NA - No range was calculated; only one facility reported a nonzero flow.

Common sources of wastewater in the coal mining industry include precipitation, surface runoff, ground water infiltration, and coal preparation plant effluent. No process water is used during the coal mining process. Preparation plants use water for washing the coal to remove impurities. The wastewater content from coal mining facilities varies according to mine location, soil content, and purity of the coal extracted. There does not appear to be a correlation between production rate and wastewater volume. Table 5-112 presents characteristics of different classifications of coal mine wastewater.

Table 5-112. Sources of Process Wastewater in Coal Mining

Wastewater Source	Characteristics
Acid mine drainage	Suspended solids, low pH, high concentrations of iron and other metals
Alkaline mine drainage	Low levels of suspended solids, neutral or slightly high pH, low concentrations of metals
Preparation plants	High levels of coal fines.
Reclamation	Variable levels of suspended solids, low concentrations of iron & manganese

Source: US EPA, 1981. *Development Document for Effluent Limitations Guidelines and Standards for the Coal Mining Point Source Category*, EPA 440-1-81-057b.

Pollutants Discharged

Table 5-113 lists the pollutants reported to PCS for coal mining facilities (major dischargers) that reported to PCS in 2000. Table 5-114 lists the direct discharges by pollutant as reported to 2000 TRI for coal mining facilities.

Table 5-113. Pollutant Discharges Reported to PCS and TRI in 2000

Pollutant Category and Primary Pollutants	PCS (Pounds/yr)	PCS TWPE/yr	TRI (Pounds/yr) (Direct Only)	TRI TWPE/yr (Direct Only)
All Pollutants	33,529,627	1,385	741,083	22,472
Nonconventional	31,563,104	1,380	739,958	2,245
Total Dissolved Solids (TDS)	31,471,976	n/a	–	–
Manganese	11,621	818 (59%)	16,400	1,155 (51%)
Iron	7,742	434 (31%)	–	–
Ammonia as Nitrogen	–	–	723,229	1,089 (49%)
Conventional	1,966,515	0	0	0
TSS	1,966,357	–	–	–
BOD ₅	96	–	–	–
Oil and Grease	62	–	–	–
Priority	8¹	5¹	1,125	20,227
Mercury	–	–	149	17,444 (86%)
Arsenic	–	–	769	2,668 (13%)

¹Copper discharge.

Relative to other industries evaluated, TWPE discharges for this category are low. Generally, a few facilities drive the TWPE estimates from both TRI and PCS. For comparison, Tables 5-114 and 5-115 present the TWPE for coal mining along with the industries reporting the highest discharges in each database. Table 5-114 presents the information reported to PCS and Table 5-115 presents the information reported to TRI. For a description of the derivation of the values in these tables, see the memorandum in the public docket titled *Description and Results of EPA Methodology to Synthesize Screening Level Results for the Effluent Guidelines Program Plan for 2004*, which is available through Edocket at document number OW-2003-0074-0391.

Table 5-114. Coal Mining TWPE Reported to PCS Compared to Industries Reporting 10 Highest Discharges

40 CFR Part	Point Source Category	PCS-Reported TWPE/yr	PCS Rank
423	Steam Electric Power Generation	2,933,209	1
414	Organic Chemicals, Plastics and Synthetic Fibers	1,805,928	2
422	Phosphate Manufacturing	1,095,321	3
415	Inorganic Chemicals Manufacturing	853,568	4
421	Nonferrous Metals Manufacturing	434,925	5
440	Ore Mining and Dressing	383,560	6
410	Textile Mills	296,601	7
419	Petroleum Refining	198,251	8
455	Pesticide Chemicals Manufacturing, Formulating	178,977	9
418	Fertilizer Manufacturing	116,464	10
434	Coal Mining	1,385	32

Source: EPA, *PCSLoads2000*.**Table 5-115. Coal Mining TWPE Reported to TRI Compared to Industries Reporting 10 Highest Discharges**

40 CFR Part	Point Source Category	TRI-Reported TWPE/yr	TRI Rank
414	Organic chemicals, plastics and synthetic fibers	7,303,782	1
423	Steam electric power generation	1,856,645	2
421	Nonferrous metals manufacturing	978,450	3
430	Pulp, paper and paperboard (Phase II)	628,785	4
415	Inorganic chemicals manufacturing	624,250	5
429	Timber products processing	404,926	6
419	Petroleum refining	385,347	7
455	Pesticide chemicals manufacturing, formulating	324,393	8
428	Rubber manufacturing	166,343	9
463	Plastic molding and forming	106,189	10
434	Coal Mining	22,472	21

Source: EPA, *TRIRelases2000*.

5.5.3.4 Treatment Technology and Pollution Prevention

Acid Discharges

Mines with acid discharges treat wastewater using chemical precipitation, pH adjustment, aeration, and settling. Neutralization and aeration promote oxidation of metals such as iron and magnesium. The metal ions form insoluble metal hydroxides, which precipitate out of solution and may be removed by settling.

Acid mine drainage is caused by the oxidation of pyrite, which release iron, sulfide, and hydrogen ions into surface waters. In some locations, manganese also may be released. The rate of acid formation is dependent on the amount of pyrite in overburden, the presence of limestone or other neutralizers, and exposure to air containing the oxygen necessary for oxidation. Special handling techniques and water management may be applied to reduce acid mine drainage. Special handling techniques include identifying potentially acid rock prior to placement, and strategically locating potentially acid materials to minimize exposure to water and air. Water management techniques include: 1) installing high wall drainage systems to promote surface runoff and reduce contact between water and the spoil surface; 2) installing spoil drains to minimize contact time between groundwater and mine spoil; 3) filling trenches with alkaline material to lower the rate of acid formation; and 4) flooding acid-forming materials to avoid air contact.

Alkaline Discharges

Some mines with alkaline discharges use settling ponds to remove suspended solids from wastewater.

Preparation Plants

These plants use a slurry treatment system, consisting of a settling basin or clarifier and thickeners, to treat the coal wash water. Runoff from surrounding areas is treated in a settling pond.

Reclamation Areas

Such areas use sedimentation ponds to remove solids from wastewater.

5.5.3.5 Industry Trends

Table 5-116 compares information from the 1992 and 1997 Economic Census for the coal mining industry. U.S. Census data indicates a decrease in the number of the number of coal mines by almost 40 percent between 1992 and 1997. Value of goods shipped also declined by 10 percent or more for bituminous coal during the same time period. Anthracite mining showed an almost 14-percent increase in value of goods shipped.

In addition to U.S. Census data, statistics for the coal mining industry are provided by the U.S. Department of Labor and the Energy Information Administration (EIA). Table 5-117 presents the number of coal operations in the U.S. from 1997 to 2002, generally decreasing by around 20 percent. Table 5-118 presents coal production from 1996 to 2000, which remains steady.

Table 5-116. 1992 and 1997 Census Data

SIC	Sector	Number of Establishments			Value of Goods Shipped (in billions of dollars)		
		1997	1992	Percent Change	1997	1992	Percent Change
1221	Bituminous coal and lignite - surface	829	1,359	-39.0	12.5	13.8	-9.9
1222	Bituminous coal - underground	614	1,008	-39.1	10.8	12.6	-14.4
1231	Anthracite mining	68	N	N	0.18	0.16	13.8

Source: 1997 U.S. Economic Census.
N - Comparable data were not available.

Table 5-117. Number of U.S. Coal Mining Operations from 1997 to 2002

Operations	1997	1998	1999	2000	2001	2002	Percent Change from 1997 to 2002
Underground Mines	968	910	817	771	777	711	-26.5
Surface Mines	1,117	1,069	1,011	920	937	921	-17.5
Preparation Plants	432	422	399	363	354	355	-17.8
Total Mining Operations	2,578	2,459	2,274	2,099	2,122	2,046	-20.6

Source: U.S. Department of Labor.

Table 5-118. U.S. Coal Production from 1997 to 2000 (in millions of short tons)

	1996	1997	1998	1999	2000	Average Annual Percent Change (1996-2000)
Total U.S. Production	1,064	1,090	1,118	1,100	1,074	0.20

Source: EIA web page.

5.5.3.6 Stakeholder and EPA Regional Issues

This subsection discusses stakeholder and EPA Regional issues. EPA primarily received input from stakeholders and EPA Regional staff prior to the Preliminary Effluent Guidelines Plan. EPA did not receive any comments on the Preliminary Plan pertaining to the coal mining industry.

Concerns Identified Pre-Proposal

Several groups surveyed by the Agency in the process of the 2004 annual review provided input on the Coal Mining category. Their suggestions and/or concerns are summarized below.

Comments on the 2002/2003 Plan (Section 2.3 of the “Factor 4 Analysis: Implementation and Efficiency Considerations - Status of Screening Level Review Phase” (Edocket OW-2003-0074-0329))

A commenter asserted that the effluent guidelines for the Coal Mining category require revision because rainfall exemptions for coal mining in the current effluent guidelines allow for relaxation of limits as soon as it rains. Furthermore, the commenter stated that settlement basins used as primary control for mine drainage do not work very well when it rains. (Note: EAD recently revised these effluent guidelines, with revisions promulgated in January 2002; however, the revised rule did not reassess the effluent limitations for precipitation events.)

Previous Suggestions (Section 2.4 of the “Factor 4 Analysis: Implementation and Efficiency Considerations - Status of Screening Level Review Phase” (Edocket OW-2003-0074-0329))

Although responders recommended coal mining for revised effluent guidelines development, no specific concerns were noted.

AMSA & ASIWPCA (Section 2.6 of the “Factor 4 Analysis: Implementation and Efficiency Considerations - Status of Screening Level Review Phase” (Edocket OW-2003-0074-0329))

A stakeholder noted that coal mining operations discharge manganese, which is generating problems, notably in West Virginia streams. In follow-up discussion with this stakeholder, EPA explained that manganese in coal mining effluent does not necessarily adversely effect the receiving stream as much as the discharge stream remaining after treatment to remove manganese, which consists basically of increasing the pH. (The water quality standard for manganese is based on concerns for staining relative to drinking water uses.) The effluent then must be neutralized before discharge; options typically include adding either acid or aluminum to the effluent. (Another side effect of changing the pH is the potential increase in

concentration of the more toxic selenium in the effluent, since it can more readily leach into the water from the pit cleanings.)

EPA appreciates all comments and suggestions provided by the stakeholders and EPA Regional staff. However, as with any comments it receives, EPA can not address these suggestions without adequate supporting data. In the event that stakeholders provide additional data and supporting information on these or any of the issues identified above, EPA will reevaluate them at that time.

5.5.3.7 Conclusions

Based on information reported to TRI and PCS, toxic discharges from coal mining operations are low relative to other industrial categories. In addition, a few facilities generally contribute the bulk of the TWPE for this industry. The pollutants driving the TWPE estimate for these few facilities are mercury and arsenic.

Stakeholders and EPA staff identified various issues associated with discharges from coal mining operations. The information in the docket on the 2004 annual review does not at this time support the concerns raised. In the event that stakeholders provide additional data and supporting information during subsequent review cycles, EPA will reevaluate them at that time.

5.5.4 **Coil Coating (Part 465)**

During the screening-level review phase of the 2004 annual review, coil coating, including the can making subcategory, was one of eight industrial categories identified solely through Factor 4 concerns. Issues driving the concerns include changes to industry since promulgation, such as: 1) discharges of new solvents adopted by the industry and not regulated by existing guidelines, 2) costs to monitor pollutants no longer used by the industry, and 3) applicability issues for multi-process facilities.

5.5.4.1 Industry Description

The Coil Coating Point Source Category is regulated at 40 CFR Part 465. This point source category includes facilities reporting under SIC industry group 341, Metal Cans and Shipping Containers. Specifically, it includes SIC code 3411, Metal Cans. The SIC description for metal cans is establishments primarily engaged in manufacturing metal cans from purchased materials. The canmaking subcategory was identified during the Factor 4 analysis.

Facility Counts

EPA obtained information on the number of facilities in the Coil Coating Point Source Category from three sources: the 1997 U.S. Economic Census, *TRIRelases2000*, and *PCSLoads2000*. The 2000 TRI database includes facilities reporting discharges to any media. In

contrast, the 2000 PCS database includes only facilities that are permitted for discharge to surface waters. Table 5-119 lists the number of facilities from these sources.

Table 5-119. Number of Facilities

SIC	1997 Census	PCS			TRI				
		Total	Major Dischargers	Minor Dischargers	Total	No Reported Discharge	Direct Discharge	Indirect Discharge	Both Direct & Indirect
3411	274	8	0	8	136	94	1	41	0

Source: EPA, PCSLoads2000, TRIReleases2000.

No facilities for this SIC code reported to PCS as major dischargers. Eight minor dischargers report to PCS under SIC code 3411, but these facilities do not need to report their discharge data. There are 42 facilities that report discharges to TRI; all but one of these report only indirect discharges. Facilities are located in 21 states and Puerto Rico. Of the 42 facilities, 10 are located in EPA Region 5.

5.5.4.2 Regulatory Background

The current ELGS for the Coil Coating Point Source Category, 40 CFR Part 465, contain four subcategories (Subpart A - D), which are based on the material used or product (e.g., metal cans). EPA promulgated final versions of the effluent limitations for Subparts A - C on October 30, 1982 and promulgated effluent limitations for Subpart D (Canmaking) in November 1983.

The technology basis of existing regulations for Subparts A - C is:

- Recycle, cyanide treatment, chromium reduction, oil removal, lime precipitation and sedimentation, and sludge dewatering for BPT;
- Cyanide treatment, chromium reduction, oil removal, lime precipitation and sedimentation for BAT and PSES;
- Recycle, cyanide treatment, chromium reduction, oil removal, chemical precipitation and sedimentation, and sludge dewatering for NSPS; and
- Recycle, cyanide treatment, chromium reduction, chemical precipitation and sedimentation, and sludge dewatering for PSNS.

The technology basis for existing regulations for Subpart D is:

- Wastewater flow normalization, chromium reduction, oil removal, and lime precipitation and sedimentation for BPT;

- In-process flow reduction, chromium reduction, oil removal, and lime precipitation and sedimentation for BAT and PSES; and
- BPT end-of-pipe treatment and in-process flow reduction for NSPS and PSNS.

Effluent limitations guidelines are mass-based on the basis of milligram (mg) per surface area processed in square meters (m²) and grams (g) per one million cans produced. BCT was deferred for all Subparts (A-D). Table 5-120 lists these limitations.

Table 5-120. Effluent Guidelines for Coil Coating and Canmaking

Pollutant	BPT 30-day averages		BAT 30-day averages		NSPS 30-day averages		PSES 30-day averages		PSNS 30-day averages	
	Subparts A-C (mg/m ²)	Subpart D (g/1 million cans)	Subparts A-C (mg/m ²)	Subpart D (g/1 million cans)	Subparts A-C (mg/m ²)	Subpart D (g/1 million cans)	Subparts A-C (mg/m ²)	Subpart D (g/1 million cans)	Subparts A-C (mg/m ²)	Subpart D (g/1 million cans)
Chromium	0.45-0.58	38.70	0.16-2.0	15.10	0.052-0.47	11.45	0.16-0.20	15.10	0.052-0.047	11.45
Copper	2.61 ²	NR	0.90 ³	NR	0.21 ²	NR	0.90 ²	83.90	0.21 ²	63.60
Cyanide	0.32-0.41	NR	0.11-0.14	NR	0.028-0.25	NR	0.11-0.14	NR	0.025-0.38	NR
Zinc	1.46-1.89	131.15	0.51-0.66	51.18	0.14-0.20	38.80	0.51-0.66	51.18	0.14-0.20	38.80
Aluminum	6.26 ³	688.00	1.84 ³	268.48	0.59 ³	203.52	NR	NR	NR	NR
Iron	1.65-1.74	5676.00	0.57-0.74	2214.96	0.20-0.22	1679.04	NR	2214.96	NR	1679.04
Phosphorous	NR	1468.45	NR	573.04	NR	434.39	NR	573.04	NR	434.39
Manganese	NR	NR	NR	NR	NR	NR	NR	24.33	NR	18.44
Oil and grease	31.31-40.4	2580	NR	NR	3.16-4.75	763.20	NR	1006.80	NR	763.20
TSS	52.2-67.3	4192.5	NR	NR	3.79-5.70	1240.20	NR	NR	NR	NR
TTO ¹	NR	NR	NR	NR	NR	NR	NR	12.59	NR	9.54
pH	7.5-10.0	7.0-10.0	NR	NR	7.5-10.0	7.0-10.0	NR	NR	NR	NR

NR = Not regulated

¹Total toxic organic pollutants include 1,1,1-Trichloroethane, 1,1-Dichloroethane, 1,1,2,2-Tetrachloroethane, Bis (2-chloroethyl) ether, Chloroform, 1,1-Dichloroethylene, Methylene chloride (dichloromethane), Pentachlorophenol, Bis (2-ethylhexyl) phthalate, Butyl benzyl-phthalate, Di-N-butyl phthalate, Phenanthrene, Tetrachloroethylene, and Toluene.²Subpart B only.³Subpart C only.

Pretreatment standards for total toxic organics (TTO) were established for new and existing sources in the canmaking subcategory. EPA detected 14 organic compounds at quantifiable levels during wastewater sampling, and selected these compounds to be included in the regulation. According to Part 465, TTO is the sum of the mass of each of the following toxic organic compounds that are found at a concentration greater than 0.010 mg/l:

- | | |
|---------------------------------------|----------------------------|
| 1,1,1-Trichloroethane; | 1,1-Dichloroethane; |
| 1,1,2,2-Tetrachloroethane; | Bis (2-chloroethyl) ether; |
| Chloroform; | 1,1-Dichloroethylene; |
| Methylene chloride (dichloromethane); | Pentachlorophenol; |
| Bis (2-ethylhexyl) phthalate; | Butyl benzyl-phthalate; |
| Di-N-butyl phthalate; | Phenanthrene; |
| Tetrachloroethylene; and | Toluene. |

Other Effluent Guidelines

40 CFR Part 467 (Aluminum Forming) is applicable to rolling, drawing, extruding, forging, and related operations such as heat treatment, casting, and surface treatments. For the purposes of this regulation, surface treatment of aluminum is considered to be an integral part of aluminum forming whenever it is performed at the same plant site at which the aluminum is formed.

Most major facilities reporting to PCS report discharge outfall flow rates. Because no major dischargers from this industry reported to PCS in 2000, EPA is not providing information on annual flow rates.

5.5.4.3 Wastewater Characterization and Pollutant Sources

Wastewater pollutant loads depend on the base material and the production process used. Table 5-121 illustrates the processes and the associated pollutants.

Table 5-121. Sources of Process Wastewater in Coil Coating and Canmaking

Process	Wastewater Pollutants
Cleaning	Metals, suspended solids, oil
Conversion coating	Metals, suspended solids
Finishing	Suspended solids
Canmaking	Metals, oil, toxic organics, suspended solids

Sources: EPA, *Development Document for Effluent Limitations Guidelines and Standards for the Coil Coating Point Source Category (Phase I) [Final]* (EPA 440-1-82-071), 1982 and *Development Document for Effluent Limitations Guidelines and Standards for the Coil Coating Point Source Category (Canmaking Subcategory) -Final* (EPA 440-1-83-071), 1983.

Pollutants Discharged

As indicated previously, no major coil coating and canmaking facilities reported discharging to PCS in 2000. Therefore, EPA has no information in *PCSLoads2000* on pollutants discharges from this industry. Table 5-122 lists the pollutants reported to TRI as discharged directly or indirectly for coil coating and canmaking facilities that reported to TRI for 2000. Indirect discharging facilities reported transfers to POTWs. Using average POTW removal efficiencies, EPA estimated the amount of pollutant discharged to surface water (see DCN 00618, *Evaluation of RSEI Model Runs*, for more information). Therefore, the TWPE estimates in this table have been adjusted to account for POTW treatment. Of the 42 TRI reporting facilities, a single indirect discharging facility contributes 99 percent of the toxic-weighted pounds.

Table 5-122. Pollutant Discharges Reported to PCS and TRI

Pollutant Category and Primary Pollutants	PCS (Pounds/yr)	PCS TWPE/yr	TRI (Pounds/yr)	TRI TWPE/yr
All Pollutants	-	-	32,803	11,763
Nonconventional	-	-	32,803	11,763
Sodium Nitrite	-	-	31,210 (95%)	11,652 (99%)
Manganese	-	-	1,592 (5%)	112 (1%)
Conventional	-	-	-	-
Priority	-	-	-	-

Relative to other industries evaluated, TWPE discharges in TRI for this industry are low. Discharges from a single facility contribute over 99 percent of the total TWPE. For comparison purposes, Tables 5-123 and 5-124 present the TWPE for the coil coating industry along with the industries reporting the highest discharges in each database. Table 5-123 presents the information reported to PCS and Table 5-124 presents the information reported to TRI. For a description of the derivation of the values in these tables, see the memorandum in the public docket titled *Description and Results of EPA Methodology to Synthesize Screening Level Results for the Effluent Guidelines Program Plan for 2004*, which is available through EdoCKET at document number OW-2003-0074-0391.

Table 5-123. Coil Coating TWPE Reported to PCS Compared to Industries Reporting 10 Highest Discharges

40 CFR Part	Point Source Category	PCS-Reported TWPE/yr	PCS Rank
423	Steam Electric Power Generation	2,933,209	1
414	Organic Chemicals, Plastics and Synthetic Fibers	1,805,928	2
422	Phosphate Manufacturing	1,095,321	3
415	Inorganic Chemicals Manufacturing	853,568	4

Table 5-123 (Continued)

40 CFR Part	Point Source Category	PCS-Reported TWPE/yr	PCS Rank
421	Nonferrous Metals Manufacturing	434,925	5
440	Ore Mining and Dressing	383,560	6
410	Textile Mills	296,601	7
419	Petroleum Refining	198,251	8
455	Pesticide Chemicals Manufacturing, Formulating	178,977	9
418	Fertilizer Manufacturing	116,464	10
465	Coil Coating	0	

Table 5-124. Coil Coating TWPE Reported to TRI Compared to Industries Reporting 10 Highest Discharges

40 CFR Part	Point Source Category	TRI Reported TWPE/yr	TRI Rank
414	Organic Chemicals, Plastics and Synthetic Fibers	7,303,782	1
423	Steam Electric Power Generation	1,856,645	2
421	Nonferrous Metals Manufacturing	978,450	3
430	Pulp, Paper and Paperboard (Phase II)	628,785	4
415	Inorganic Chemicals Manufacturing	624,250	5
429	Timber Products Processing	404,926	6
419	Petroleum Refining	385,347	7
455	Pesticide Chemicals Manufacturing, Formulating	324,393	8
428	Rubber Manufacturing	166,343	9
463	Plastic Molding and Forming	106,189	10
434	Coil Coating	11,763	25

5.5.4.4 Treatment Technology and Pollution Prevention

Coil Coating

Standard treatment for coil coating may include chemical precipitation and sedimentation, oil removal, cyanide removal, chromium reduction, or filtration.

Canmaking

Standard treatment for canmaking may include chemical precipitation and sedimentation, oil removal, filtration, neutralization, chemical emulsion breaking, or dissolved

air flotation. Oil skimming was used as the technology basis for TTO removal for the canmaking subcategory. Since toxic organics detected in canmaking wastewater are similar to those in aluminum forming and coil coating wastewater, EPA used the removal rate from aluminum forming plants to predict the organics removal for canmaking. On average, aluminum forming plants achieve a 97-percent removal of organics by oil skimming.

Pollution Prevention

Recycle and reuse, and use of alternative cleaning or conversion coating agents are the focus of current pollution prevention activities. Some facilities have achieved zero discharge by evaporating wastewater to leave a dry residue. Separating waste streams can increase the efficiency of the wastewater treatment system and reduce the pounds of chemicals added for treatment. Table 5-125 lists pollution prevention alternatives for this industry.

Table 5-125. Water Conservation and Pollution Prevention Alternatives

Process	Water Conservation/Pollution Prevention Alternatives
Aluminum coil coating	Install ultrafiltration units to remove aluminum etchings from cleaning solutions. This extends the life of cleaning solutions, thus reducing use of cleaning solvents, and reduces discharges of aluminum in effluent.
Cleaning	Reduce dragout. Reuse of alkaline cleaning rinse water as make-up to the alkaline cleaning tank. Multistage countercurrent rinses.
Conversion coating	Use a chromium regeneration system. Recycle and reuse rinse water. Recycle quench water. Use cyanide-free chromating solutions. Use zinc-free sealing rinses. Use no-rinse conversion coating in place of chromate conversion coating.
Finish coating	Use solvent-free wax to reduce organic emissions, reduce gas consumption formerly required to dry the wax/solvent mixture, and reduce combustion by-products from drying and oxidation process.
Can coating	Use radiation-cured coatings to reduce VOC emissions and eliminate/reduce the need for carrier solvents.

Source: EPA, *Development Document for Effluent Limitations Guidelines and Standards for the Coil Coating Point Source Category (Phase I) [Final]* (EPA 440-1-82-071), 1982 and *Development Document for Effluent Limitations Guidelines and Standards for the Coil Coating Point Source Category (Canmaking Subcategory) -Final* (EPA 440-1-83-071), 1983 and industry web sites.

5.5.4.5 Industry Trends

U.S. Economic Census data indicate a decrease in the number of metal canmaking facilities by 15 percent between 1992 and 1997 (see Table 5-126). The value of goods shipped has also declined by less than 1 percent during the same time period.

In Table 5-127, advance comparative statistics for 1997 to 2002 for NAICS code 332 (Fabricated Metal Product Manufacturing) show a continuing decrease in the number of establishments of almost 3 percent, but just over a 1-percent increase in the value of shipments (not adjusted for inflation). Table 5-128 illustrates the increase in can shipments since 1982.

Table 5-126. 1992 and 1997 Census Data

SIC Code	Industry Segment	Number of Establishments			Value of Goods Shipped (in billions of dollars)		
		1997	1992	Percent Change	1997	1992	Percent Change
3411	Metal Cans	274	324	-15	12.0	12.1	-0.6

Source: 1997 U.S. Economic Census.

Table 5-127. 1997 and 2002 Census Data

NAICS Code	Industry Segment	Number of Establishments			Value of Goods Shipped (billions of dollars)		
		2002	1997	Percent Change	2002	1997	Percent Change
332	Fabricated Metal Product Mfr.	60,602	62,384	-2.8	245	242	1.2

Source: 2002 U.S. Economic Census.

Table 5-128. Can Shipments by Category

Year	Can Shipments in Billions of Cans		
	Food	Beverage	General Line
1982	27.6	57.9	3.8
1992	30.9	95.7	4.1
2002	31.3	100.5	4.4

Source: CanCentral.com.. <<http://www.cancentral.com>> Accessed on July 6, 2004.

5.5.4.6 Stakeholder and Regional Issues

This subsection discusses stakeholder and Regional issues. EPA primarily received input from stakeholders and EPA Regional staff prior to the Preliminary Effluent Guidelines Plan. EPA did not receive any comments on the Preliminary Plan pertaining to the coil coating and canmaking industry.

Concerns Identified Pre-Proposal

Several groups surveyed by the Agency in the process of the 2004 annual review provided input on the Coil Coating category and the Canmaking subcategory. Their suggestions are summarized below.

Consultations with Permitting Authorities (Section 2.5 of the “Factor 4 Analysis: Implementation and Efficiency Considerations - Status of Screening Level Review Phase” (Edocket OW-2003-0074-0329))

EPA permit writers and pretreatment coordinators note that the industry has changed since the effluent guidelines were promulgated in 1983. The industry is using completely different solvents than those assessed during the development of the existing guidelines. However, EPA has received no data to support this observation. EPA permit writers and pretreatment coordinators are also concerned about the costs associated with monitoring requirements for pollutants that are no longer used by the industry. In addition, permitting authorities in EPA Regions 2 and 5 and stakeholders in Alabama and Tennessee have identified applicability issues. Questions focused on facilities with multiple processes that also perform coal coating, most recently aluminum forming facilities.

EPA appreciates all comments and suggestions provided by the stakeholders and EPA Regional staff. However, as with any comments it receives, EPA cannot address these suggestions without adequate supporting data. In the event that stakeholders provide additional data and supporting information on these or any of the issues identified above, EPA will reevaluate them at that time.

EPA notes that, for direct dischargers, permit writers can reduce the frequency of required monitoring through the provisions described at 40 CFR Part 122.44(1)(2) “monitoring waivers for certain guideline-listed pollutants.” (This is not available during the term of the first permit.) For indirect discharges, the Office of Wastewater Management plans to finalize (in December 2004) a waiver provision for “pollutants not present” under the National Pretreatment Program’s streamlining regulation. That regulation is projected to be final in December 2004.

5.5.4.7 Conclusions

Based on information reported to TRI and PCS, toxic discharges from coil coating and canmaking operations are low relative to other industrial categories. Discharges from a single facility contribute over 99 percent of the total TWPE.

Stakeholders and EPA staff identified various issues associated with discharges from coil coating and canmaking plants. The information in the docket on the 2004 annual review does not at this time support the concerns raised. In the event that stakeholders provide additional data and supporting information during subsequent review cycles, EPA will reevaluate them at that time.

5.5.5 Dairy Products Processing (Part 405)

During the screening-level review phase of the 2004 annual review, dairy processing was one of eight industrial categories identified solely through Factor 4 concerns. Issues driving the concerns include overloading of POTWs and small streams (for direct dischargers) receiving wastewater from this industry with nutrients and conventional pollutants such as BOD and oil and grease.

5.5.5.1 Industry Description

The Dairy Products Processing Point Source Category is regulated at 40 CFR Part 405. This point source category includes facilities reporting under SIC industry group 202, Dairy Products. Specifically, it includes SIC codes 2021 (Creamery Butter), 2022 (Natural, Processed, and Imitation Cheese), 2023 (Dry, Condensed, and Evaporated Dairy Products), 2024 (Ice Cream and Frozen Desserts), and 2026 (Fluid Milk). No specific subcategories were identified during the Factor 4 analysis. Below is a description of these SIC codes:

- SIC code 2021 - *Creamery Butter*. Establishments primarily engaged in manufacturing creamery butter.
- SIC code 2022 - *Natural, Processed, and Imitation Cheese*. Establishments primarily engaged in manufacturing natural cheese (except cottage cheese), processed cheese, cheese foods, cheese spreads, and cheese analogs (imitations and substitutes). These establishments also produce by-products, such as raw liquid whey. Establishments primarily engaged in manufacturing cottage cheese are classified in SIC code 2026, and those manufacturing cheese-based salad dressings are classified in SIC code 2035.
- SIC code 2023 - *Dry, Condensed, and Evaporated Dairy Products*. Establishments primarily engaged in manufacturing dry, condensed, and evaporated dairy products. Included in this industry are establishments primarily engaged in manufacturing mixes for the preparation of frozen ice cream and ice milk and dairy and nondairy base cream substitutes and dietary supplements.
- SIC code 2024 - *Ice Cream and Frozen Desserts*. Establishments primarily manufacturing ice cream and other frozen desserts. Establishments primarily engaged in manufacturing frozen bakery products, such as cakes and pies, are classified in SIC code 2053.
- SIC code 2026 - *Fluid Milk*. Establishments primarily engaged in processing (e.g., pasteurizing, homogenizing, vitaminizing, bottling) fluid milk and cream and related products, including cottage cheese, yogurt

(except frozen), and other fermented milk. Establishments primarily engaged in manufacturing dry mix whipped toppings are classified in SIC code 2023; those producing frozen whipped toppings are classified in SIC code 2038; and those producing frozen yogurt are classified in SIC code 2024.

Facility Counts

EPA obtained information on the number of facilities in the Dairy Products Processing category from three sources: the 1997 U.S. Economic Census, *TRIReleases2000*, and *PCSLoads2000*. The 2000 TRI database includes facilities reporting discharges to any media. In contrast, the 2000 PCS database includes only facilities that are permitted for discharge to surface waters. Table 5-129 lists the number of facilities from these sources.

Table 5-129. Number of Facilities in the Dairy Products Processing Category

SIC Code	1997 U.S. Economic Census	PCS			TRI				
		Total	Major Dischargers	Minor Dischargers	Total Reporters	No Reported Discharge	Direct Discharge	Indirect Discharge	Both Direct & Indirect
2021	34	4	0	4	18	2	2	14	0
2022	525	27	2	25	141	37	22	82	0
2023	215	15	2	13	52	11	7	34	0
2024	451	6	0	6	20	8	0	11	1
2026	613	29	1	28	94	40	1	53	0

Source: EPA, *PCSLoads2000* and, *TRIReleases2000*.

Of the 220 reporting facilities, over 50 percent are located in four states: Wisconsin (48 facilities), California (28 facilities), Minnesota (21 facilities), and New York (18 facilities). The rest are located in 30 other states. Almost 50 percent of the reporting facilities are part of SIC code 2022 (Natural, Processed, and Imitation Cheese).

5.5.5.2 Regulatory Background

The current ELGS for the Dairy Products Point Source Category, 40 CFR Part 405, contain 12 subcategories (Subpart A - L). EPA promulgated final versions of the effluent limitations in 1974. Table 5-130 summarizes the current ELGS. The technology basis of existing regulations was:

In-plant control: Establishing a plant management improvement program to adopt water conservation practices, installing waste monitoring equipment, improving plant maintenance, improving production scheduling practices, improving quality control, finding alternative uses for products currently wasted to drain, and improving housekeeping and product-handling practices.

End-of-Pipe Control: For large plants- biological treatment system (activated sludge, trickling filter, or aerated lagoon).

For small plants- anaerobic digestion- stabilization lagoon system, and irrigating with wastewater by spray or ridge and furrow where land is available and it is economically feasible.

For all subcategories, EPA did not establish PSES or PSNS. In addition, for all subcategories, EPA set BCT equal to BPT.

Table 5-130. Effluent Guidelines for Dairy Products Processing Part 405

Effluent Characteristic	Subpart	BPT		NSPS	
		Daily Maximum ¹	Monthly Average Maximum ¹	Daily Maximum	Monthly Average Maximum
BOD ₅ (lbs per 100 lbs of BOD ₅ input)	A	0.048-0.063	0.019-0.313	0.010	0.005
	B and C	0.338-0.450	0.135-0.225	0.074	0.037
	D	0.138-0.183	0.055-0.091	0.016	0.008
	E	0.670-0.893	0.268-0.446	0.148	0.074
	F	0.073-0.098	0.029-0.049	0.016	0.008
	G	0.220-0.293	0.068-0.146	0.048	0.024
	H	0.460-0.613	0.184-0.306	0.094	0.047
	I	0.345-0.460	0.138-0.230	0.076	0.038
	J	0.163-0.218	0.065-0.109	0.036	0.018
	K and L	0.100-0.130	0.040-0.065	0.022	0.011
TSS (lbs per 100 lbs of BOD ₅ input)	A	0.071-0.094	0.029-0.469	0.013	0.006
	B	0.551-0.675	0.203-0.338	0.093	0.046
	C	0.506-0.675	0.203-0.338	0.093	0.046
	D	0.206-0.274	0.083-0.137	0.020	0.010
	E	1.005-1.339	0.402-0.669	0.185	0.093
	F	0.109-0.146	0.044-0.073	0.020	0.010
	G	0.330-0.439	0.132-0.219	0.060	0.030
	H	0.690-0.919	0.276-0.459	0.118	0.059
	I	0.518-0.690	0.207-0.345	0.095	0.048
	J	0.244-0.328	0.098-0.164	0.045	0.023
	K	0.150-0.195	0.060-0.098	0.028	0.014
	L	0.150-0.195	0.060-0.098	0.023	0.014
pH	All	6-9	6-9	6-9	6-9

¹The range of values represent limits for different size operations.

5.5.5.3 Wastewater Characteristics and Pollutant Sources

Most major facilities reporting to PCS report discharge outfall flow rates. Table 5-131 presents the total annual flow (in millions of gallons) for 2000, median annual discharge flow, and the range of annual flows for dairy products processing facilities. Facilities not reporting a flow were not included in the median calculation. Data presented in Table 5-131 are based on major dischargers reporting to PCS for 2000.

Table 5-131. Wastewater Flows

SIC	Number of Major Facilities Reporting Nonzero Flows	Median Facility Flow In 2000 (MGY)	Range of Facility Flows In 2000 (MGY)	Total Flow In 2000 (MGY)
2022	2	88	68-109	177
2023	2	202	71-333	404
2026	1	250	NA	250

Source: EPA, *PCSLoads2000*.

NA - No range calculated: only one facility reported a nonzero flow.

Most dairy plants discharge their wastewater to POTWs. The primary pollutants found in dairy processing plant wastewater are organics and TSS; additional pollutants include phosphorus, nitrogen, chlorides, and heat. Effluent guidelines are not set for these additional pollutants; however, control and treatment of the primary pollutants (organics and TSS) help to maintain these additional pollutants at an acceptable level. Dairy processing wastewater experiences daily and seasonal fluctuations in temperature, flow, and pollutants. Table 5-132 presents sources of process wastewater and the associated pollutants.

Table 5-132. Sources of Process Wastewater in Dairy Products Processing

Process	Wastewater Pollutant
Washing, cleaning, and sanitizing of all pipe lines, pumps, processing equipment, tanks, tank trucks and filling machines	BOD, TSS, pH, detergents
Processing losses, such as start-up, product change-over and shut down of high temperature short time (HTST) and ultra high temperature (UHT) pasteurizers	BOD, TSS, pH, detergents
Loss in filling operations through equipment jams, leaks, and broken packages	BOD, TSS, pH
Lubrication of casers, stackers, and conveyors that ends up in the wastewater from washing	BOD, TSS, pH, detergents, oil and grease

Sources: EPA, *Development Document for Dairy Products Processing*, 1974 and *Dairy Food Plant Wastes and Waste Treatment Practices*, 1971.

Pollutants Discharged

Table 5-133 lists the pollutants reported to PCS for dairy processing facilities that reported discharges to PCS by major dischargers in 2000. In addition, Table 5-133 lists the pollutants reported to TRI as discharged directly or for dairy products processing facilities that reported to TRI for 2000. This table presents the number of facilities that reported each chemical and the total pounds of chemical discharged to surface waters. Indirect discharging facilities reported transfers to POTWs. Using average POTW removal efficiencies, EPA estimated the amount of pollutant discharged to surface water (see DCN 00618, *Evaluation of RSEI Model Runs*, for more information). Therefore, the TWPE estimates in this table have been adjusted to account for POTW treatment.

Table 5-133. Pollutant Discharges Reported to PCS and TRI

Pollutant Category & Primary Pollutants	PCS (Pounds/yr)	PCS TWPE/yr	TRI (Pounds/yr)	TRI TWPE/yr
All Pollutants	224,891	4	3,326,527	5,829
Nonconventionals	81,912	4	3,326,522	5,829
Chlorine, Total Residual	–	–	11,437	5,570 (96%)
Nitrogen, Nitrate Total (As N)	7,644	0.5	3,228,359	200 (3%)
Ammonia as Nitrogen	1,878	3 (80%)	37,160	56
Conventionals	142,979	0	0	0
TSS	97,972			
BOD ₅	42,037			
Oil and Grease	2,969			
Priority	0	0	5	0
Toluene	0	0	5	0

Relative to other industries evaluated, TWPE discharges in PCS and TRI are low. A single facility contributes over 96 percent of the overall TWPE for this industry. For comparison purposes, Tables 5-134 and 5-135 present the TWPE for dairy products processing along with the industries reporting the highest discharges in each database. Table 5-134 presents the information reported to PCS and Table 5-135 presents the information reported to TRI. For a description of the derivation of the values in these tables, see the memorandum in the public docket titled *Description and Results of EPA Methodology to Synthesize Screening Level Results for the Effluent Guidelines Program Plan for 2004*, which is available through Edocket at document number OW-2003-0074-0391.

Table 5-134. Dairy Products Processing TWPE Reported to PCS Compared to Industries Reporting Highest Discharges

40 CFR Part	Point Source Category	PCS-Reported TWPE/yr	PCS Rank
423	Steam Electric Power Generation	2,933,209	1
414	Organic Chemicals, Plastics and Synthetic Fibers	1,805,928	2
422	Phosphate Manufacturing	1,095,321	3
415	Inorganic Chemicals Manufacturing	853,568	4
421	Nonferrous Metals Manufacturing	434,925	5
440	Ore Mining and Dressing	383,560	6
410	Textile Mills	296,601	7
419	Petroleum Refining	198,251	8
455	Pesticide Chemicals Manufacturing, Formulating	178,977	9
418	Fertilizer Manufacturing	116,464	10
405	Dairy Products Processing	5	39

Table 5-135. Dairy Products Processing TWPE Reported to TRI Compared to Industries Reporting Highest Discharges

40 CFR Part	Point Source Category	TRI-Reported TWPE/yr	TRI Rank
414	Organic Chemicals, Plastics and Synthetic Fibers	7,303,782	1
423	Steam Electric Power Generation	1,856,645	2
421	Nonferrous Metals Manufacturing	978,450	3
430	Pulp, Paper and Paperboard (Phase II)	628,785	4
415	Inorganic Chemicals Manufacturing	624,250	5
429	Timber Products Processing	404,926	6
419	Petroleum Refining	385,347	7
455	Pesticide Chemicals Manufacturing, Formulating	324,393	8
428	Rubber Manufacturing	166,343	9
463	Plastic Molding and Forming	106,189	10
405	Dairy Products Processing	5,827	30

5.5.5.4 Treatment Technology and Pollution Prevention

Standard treatments include activated sludge, trickling filters, aeration lagoons, stabilization ponds, land application, and anaerobic digestion. The 1974 development document (1) suggested pretreatment practices of anaerobic digestion, high-rate trickling filter and activated sludge systems, stabilization ponds, aerated ponds, and chemical treatment. Direct discharging plants may disinfect wastewater with chlorine prior to discharge. Advanced treatment would replace chlorine disinfection with ozone or ultraviolet light. Most advances are water conservation and other pollution prevention practices.

Water conservation and pollution prevention practices reduce pollutant loads. Table 5-136 presents some pollution prevention alternatives for this industry.

Table 5-136. Pollution Prevention Alternatives for Dairy Products Processing

Type of Technique	Pollution Prevention Alternatives
Process/equipment modification	Replace traditional faucets with low-flow models.
	Shut off water during breaks.
	Install water control units.
	Install flow meters.
	Reduce exterior area water use.
Operational and housekeeping changes	Place catch pans under potential overflows/leaks to reduce cleanup.
	Cover outside storage areas.
	Conduct inspections and preventive maintenance of potential discharge areas.
	Install secondary containment.
	Monitor liquid fill machines to prevent overflows.
	Cover outside drain during loading and unloading.
	Cover inside floor drains (in nonproduction areas only).
	Prevent spills and conduct regular inspections of potential spill sites.
	Conduct precleaning and dry cleanup.
	Install screening.
	Minimize pests to reduce the need for chemical pest control.
Recycling/reuse	Use countercurrent washes.
	Reuse process water.
	Install water recirculation units.
	Use recirculating water to chill products.
	Recycle refrigerants.
	Reduce/recycle/reuse packaging.
Material substitution and elimination	Control general inventory to minimize disposal of outdated materials.
	Use alternative refrigerants.

Source: Multimedia Environmental Compliance Guide for Food Processors, EPA, 1999.

5.5.5.5 Industry Trends

1997 U.S. Economic Census data indicates the change in the number of the number of dairy products processing facilities between 1992 and 1997, as shown in Table 5-137. Although the number of facilities may have increased or decreased, depending on sector, the value of goods shipped increased by as much as 33 percent during the same time period. Advance comparative statistics for 1997 to 2002 for the broader category represented by NAICS code 311 (food manufacturing including grains, fruits and vegetables, dairy, meats, seafood, and miscellaneous food) shows a very small increase in the number of establishments (less than 1

percent) and an 8-percent increase in the value of shipments (not adjusted for inflation), as shown in Table 5-138.

Table 5-137. 1992 and 1997 Census Data

SIC Code	Industry Sector	Number of Establishments			Value of Goods Shipped (billions of dollars)		
		1997	1992	Percent Change	1997	1992	Percent Change
2021	Creamery Butter	34	31	9.7	1.4	1.0	32.9
2022	Natural, Processed, and Imitation Cheese	525	573	-8.4	20.3	16.9	20.1
2023	Dry, Condensed, and Evap. Dairy Products	215	214	0.5	9.2	7.5	21.9
2024	Ice Cream and Frozen Desserts	451	456	-1.1	5.9	5.3	11.6
2026	Fluid Milk	613	746	-17.8	22.2	21.9	1.4

Source: 1997 U.S. Economic Census.

Table 5-138. 1997 and 2002 Census Data

NAICS Code	Industry Segment	Number of Establishments			Value of Goods Shipped (billions of dollars)		
		2002	1997	Percent Change	2002	1997	Percent Change
311	Food Manufacturing	26,374	26,302	0.27	457	422	8.4

Source: 2002 U.S. Economic Census.

5.5.5.6 Stakeholder and EPA Regional Issues

This subsection discusses stakeholder and EPA regional issues. EPA primarily received input from stakeholders and EPA Regional staff prior to the Preliminary Effluent Guidelines Plan. EPA did not receive any comments to the Preliminary Plan pertaining to the dairy products processing industry.

Concerns Identified Pre-Proposal

Several groups surveyed by the Agency in the 2004 annual review provided input on the Dairy Products Processing category. Each group and their suggestions are summarized below.

Previous Suggestions (Section 2.4 of the “Factor 4 Analysis: Implementation and Efficiency Considerations - Status of Screening Level Review Phase” (Edocket OW-2003-0074-0329))

In the fall of 1999 and again in the spring of 2001, EPA requested suggestions from Headquarters, Regional, and state staff charged with the task of implementing effluent guidelines to follow up on concerns and to gather recommendations regarding which effluent guidelines the Agency might develop or revise. Responders identified dairy products processing based on concerns over the discharge of nutrients. They were also concerned about overloading POTWs and small streams (for direct dischargers) with conventional pollutants such as BOD. Another issue identified included a concern for copper in relation to dairies; however, follow-up identified this issue to be a miscommunication.

EPA appreciates all comments and suggestions provided by the stakeholders and EPA Regional staff. However, as with any comments it receives, EPA cannot address these suggestions without adequate supporting data. Some stakeholders identified nutrient discharges from dairy processing plants as a concern. Information in PCS and TRI does not indicate that dairy processing plants are discharging significant quantities of nutrients relative to other industrial categories. In the event that stakeholders provide additional data and supporting information on these or any of the issues identified above, EPA will reevaluate them at that time.

5.5.5.7 Conclusions

Based on information reported to TRI and PCS, toxic discharges from dairy processing plants are low relative to other industrial categories. Total residual chlorine discharges from a single facility contributes over 96 percent of the overall TWPE for this industry.

Stakeholders and EPA staff identified various issues associated with discharges from dairy processing plants. The information in the docket at this time does not support the concerns raised. In the event that stakeholders provide additional data and supporting information during subsequent review cycles, EPA will reevaluate them at that time.

5.5.5.8 References

1. U.S. EPA. *Development Document for Effluent Limitations Guidelines and New Source Performance Standards for the Dairy Product Processing Point Source Category*. EPA-440/1-74-021-a. Washington, D.C. May 1974.

5.5.6 Electrical and Electronic Components (Part 469)

During the screening-level review phase of the 2004 annual review, electrical and electronic components was one of eight industrial categories identified solely through Factor 4 concerns. Issues driving the concerns include: 1) significant process changes resulting in

changes in the typical pollutants discharged, including a shift from aluminum to copper, and 2) confusion over applicability of effluent guidelines for metal finishing.

5.5.6.1 Industry Description

The Electrical and Electronic Components Point Source Category is regulated at 40 CFR Part 469. This point source category includes facilities reporting under SIC major group 36, Electronic and Other Electrical Equipment and Components, Except Computer Equipment. Specifically, it includes facilities in SIC code 3671, Electron Tubes, and SIC code 3674, Semiconductors and Related Devices. No specific subcategories were identified during the Factor 4 analysis. Below is a description of the SIC codes:

- SIC code 3671: *Electron Tubes*. Establishments primarily engaged in manufacturing electron tubes and tube parts. Establishments primarily engaged in manufacturing X-ray tubes and parts are classified in SIC code 3844.
- SIC code 3674: *Semiconductors and Related Devices*. Establishments primarily engaged in manufacturing semiconductors and related solid-state devices. Important products of this industry are semiconductor diodes and stacks, including rectifiers, integrated microcircuits (semiconductor networks), transistors, solar cells, and light sensing and emitting semiconductor (solid-state) devices.

Facility Counts

Information on the number of facilities in the Electrical and Electronic Components Point Source Category was obtained from three sources: the 1997 U.S. Economic Census, *TRIReleases2000*, and *PCSLoads2000*. TRI includes facilities reporting discharges to any media. In contrast, PCS includes only facilities that are permitted for discharge to surface waters. The number of facilities from these sources is listed in Table 5-139.

Table 5-139. Number of Facilities in the Electrical and Electronic Components Category

SIC Code	1997 Census	PCS			TRI				
		Total	Major Dischargers	Minor Dischargers	Total Reporting	No Reported Discharge	Direct Discharge	Indirect Discharge	Both Direct and Indirect
3671	159	5	1	4	1	4	0	4	5
3674	1099	13	4	9	150	51	4	91	4

Source: EPA, *PCSLoads2000*, *TRIReleases2000*.

The 111 reporting facilities are located in 22 states, with the highest concentrations in California (20 percent), Texas (17 percent), Arizona (11 percent), Oregon (9 percent), and Pennsylvania (9 percent).

5.5.6.2 Regulatory Background

When promulgated, the ELGS for the Electrical and Electronic Components Point Source Category, 40 CFR Part 469, contained 21 subcategories. Seventeen of these subcategories were excluded from regulation under Paragraph 8 of the Revised Settlement Agreement. The following four categories (A - D) may apply to discharges from electrical and electronic components facilities:

- *Semiconductor Subcategory:* EPA promulgated ELGS for BPT, BAT, BCT, NSPS, PSES, and PSNS (Subpart A) in 1983.
- *Electronic Crystals Subcategory:* EPA promulgated ELGS for BPT, BAT, BCT, NSPS, PSES, and PSNS (Subpart B) in 1983.
- *Cathode Ray Tube Subcategory:* EPA promulgated ELGS for NSPS, PSES, and PSNS in 1984. Existing direct dischargers in this subcategory were excluded from regulation under Paragraph 8 of the Revised Settlement Agreement. The only direct discharger in this subcategory discharged less than two pounds per day after treatment.
- *Luminescent Materials Subcategory:* EPA promulgated NSPS and PSNS in 1984. Existing dischargers in this subcategory were excluded from regulation under Paragraph 8 of the Revised Settlement Agreement. The two direct dischargers in this subcategory each discharged less than one pound per day after treatment. The indirect dischargers were excluded on the basis that their toxic discharges to POTWs were insignificant.

Existing regulations do not include limits on conventional parameters for any of the four subcategories. BOD and oil and grease were detected at concentrations below treatability. Fecal coliform was not present in the discharges from any of the subcategories. In addition, the existing regulations do not include limits on copper.

EPA established limitations for TTO for new and existing sources in the semiconductors and electronic crystals subcategories. EPA detected several toxic organics in process wastes resulting from solvent cleaning and developing and stripping photoresist. TTO is the sum of the mass of each of the following toxic organic compounds that are found at a concentration greater than 0.010 mg/l:

- | | |
|---------------------------------|-------------------------|
| • 1,2,4-Trichlorobenzene; | • Chloroform; |
| • 1,2-Dichlorobenzene; | • 1,3-Dichlorobenzene; |
| • 1,4-Dichlorobenzene; | • Ethylbenzene; |
| • 1,1,1-Trichloroethane; | • Methylene chloride; |
| • Naphthalene; | • 2-Nitrophenol phenol; |
| • Bis (2-ethylhexyl) phthalate; | • Tetrachloroethylene; |

- Toluene;
- 2-Chlorophenol;
- 4-Nitrophenol;
- Di-n-butyl phthalate;
- 1,2-Diphenylhydrazine;
- Butyl benzyl phthalate;
- 2,4,6-Trichlorophenol;
- 1,2-Dichloroethane;
- Dichlorobromomethane.
- Trichloroethylene;
- 2,4-Dichlorophenol;
- Pentachlorophenol;
- Anthracene;
- Isophorone;
- 1,1-Dichloroethylene;
- Carbon tetrachloride;
- 1,1,2-Trichloroethane; and

Performance standards for TTO were established for new sources in the cathode ray tubes subcategory. EPA detected six toxic organics in process wastes resulting from the use of solvents for cleaning and degreasing operations, and from the application of toluene-based laquer coatings. TTO is the sum of the mass of each of the following toxic organic compounds that are found at a concentration greater than 0.010 mg/l: 1,1,1-trichloroethane; chloroform; methylene chloride; bis(2-ethylhexyl)phthalate; toluene; and trichloroethylene.

The technology basis for the limitations in each subcategory are:

- **Semiconductors:** neutralization, solvent management, in-plant precipitation of concentrated fluoride stream;
- **Electronic Crystals Manufacturing:** neutralization, solvent management, and end-of-pipe precipitation/clarification;
- **Cathode Ray Tubes:** solvent management, neutralization, and end-of-pipe precipitation/clarification; and
- **Luminescent Materials Manufacturing:** neutralization, precipitation/clarification.

Table 5-140 presents the effluent guidelines for the semiconductors and electronic crystals subcategories. Table 5-141 presents the guidelines for cathode ray tubes and luminescent materials manufacturing.

Table 5-140. Effluent Guidelines for Semiconductors and Electronic Crystals Manufacturing (Concentration-Based)

Pollutant	30-day Average Limits (mg/L)				
	BPT	BAT	BCT	NSPS	PSES & PSNS
TTO	1.37 ¹	1.37 ¹	1.37 ¹	1.37 ¹	1.37 ¹
pH	within the range of 6 to 9	NA	within the range of 6 to 9	within the range of 6 to 9	NA

Table 5-140 (Continued)

Pollutant	30-day Average Limits (mg/L)				
	BPT	BAT	BCT	NSPS	PSES & PSNS
TSS	23 ²	NA	23 ²	23 ²	NA
Fluoride	17.4 ³	17.4	NA	17.4	NA
Arsenic	0.83 ⁴	0.83d	NA	0.83 ⁴	0.83 ⁴

Source: EPA, Development Document for Phase I, 1983.

NA - No limit.

TTO - Total Toxic Organics.

¹The limit for TTO represents a daily maximum value.

²Limits for TSS only apply to the electronic crystals subcategory.

³There is no BPT limit for fluoride for the semiconductor subcategory.

⁴Limits for arsenic only apply to facilities with gallium or indium arsenide crystal manufacturing operations.

Table 5-141. Effluent Limitations and Standards for Cathode Ray Tubes and Luminescent Materials Manufacturing (Concentration-Based)

Pollutant	30-Day Average Limit (mg/L)		
	NSPS	PSES ¹	PSNS
TTO	1.58	NA	NA
pH	within the range of 6 to 9	NA	NA
TSS	18 to 31	NA	NA
Cadmium	0.03 to 0.26	0.03	0.03 to 0.26
Chromium ²	0.26	0.30	0.26
Lead ²	0.27	0.41	0.27
Zinc	0.33 to 0.67	0.56	0.33 to 0.67
Fluoride	18	18	18
Antimony ³	0.04	NA	0.04

Source: EPA, *Development Document for Effluent Limitations Guidelines for the Electrical and Electronic Components Point Source Category - Phase II* (EPA 440-1-84-075), 1984.

NA - No limit.

TTO - Total Toxic Organics.

¹PSES limits only apply to the cathode ray tubes subcategory.

²Limits for chromium and lead only apply to the cathode ray tubes subcategory.

³Limits for antimony only apply to the luminescent materials subcategory.

Related Effluent Guidelines

EPA believes that semiconductor manufacturing can be divided into two sections for the purposes of applying the requirements of 40 CFR Part 469 and Part 433: Metal Finishing. Metal finishing comprises the following processes:

- Electroplating;
- Electroless plating;
- Anodizing;
- Coating (chromating, phosphating, and coloring);
- Chemical etching and milling; and
- Printed circuit board manufacture.

For some semiconductor manufacturing operations, ELGS for the Electrical and Electronic Components category (Part 469) may be effective and applicable to wastewater discharges from Metal Finishing (Part 433) listed above. In such cases, the Part 433 limits will not apply and the Part 469 regulations will apply. EPA clarified this overlap in a memorandum dated April 21, 1998 (1). New technologies in semiconductor manufacturing include electroplating-type operations that add microscopic amounts of metal to selective portions of the wafer. These operations are distinguished from the electroplating operations that occur in the final assembly process, which is separate from wafer fabrication. EPA concluded that processes performed in a fab cleanroom before final assembly, including the electroplating-type operations, are to be regulated under 40 CFR Part 469. Part 433 applies only to processes after wafer fabrication, in which a layer of metal is deposited onto the surface of the wafer to provide contact points for final assembly.

5.5.6.3 Wastewater Characteristics and Pollutant Sources

Most major facilities reporting to PCS report discharge outfall flow rates. Table 5-142 presents the total annual flow (in millions of gallons) for 2000, median annual discharge flow, and the range of annual flows for electrical and electronic component facilities. Facilities not reporting a flow were not included in the median calculation. Data presented in Table 5-142 are based on major dischargers reporting to PCS for 2000.

Table 5-142. Wastewater Flows

SIC Code	Number of Major Facilities Reporting Nonzero Flows	Median Facility Flow In 2000 (MGY)	Range of Facility Flows In 2000 (MGY)	Total Flow In 2000 (MGY)
3671	1	191	NA	191
3674	4	1,651	59 - 15,493	18,853

Source: EPA, *PCSLoads2000*.

NA - No range calculated; only one facility reported a nonzero flow.

Table 5-143 presents sources of process wastewater and the associated pollutants identified in the 1983 and 1984 Development Documents, organized by the four subcategories in the effluent guidelines.

Table 5-143. Sources of Process Wastewater in Electrical and Electronic Components Category

Wastewater	Pollutants
Semiconductors	
Acid wastes from etching and cleaning	Fluoride, low pH, toxic organics
Water rinses	Fluoride (low levels), toxic organics
Equipment cleaning waste	Toxic organics, may have high pH if caustic cleaning agent is used.
Scrubber wastes	Toxic organics
Stripper quench rinses	Toxic organics
Chemical mechanical planarization (CMP)	Copper
Electronic Crystals	
Crystal growing operations	Sodium hydroxide, sodium carbonate
Etching	Fluoride, toxic organics
Manufacture of gallium or indium arsenic crystals	Arsenic
Cutting and grinding operations	Suspended solids
Equipment cleaning	Toxic organics
Cathode Ray Tubes	
Glass panel wash	Fluoride
Mask degrease	Toxic organics
Photoresist application	Chromium
Phosphor application	Cadmium, zinc
Glass funnel and mount cleaning	Fluoride
Tube coating	Suspended solids from graphite emulsions
Tube Salvage	Lead, cadmium, zinc, fluoride, chromium, suspended solids
Luminescent Materials	
Lamp phosphor process	Antimony, fluoride, suspended solids
Blue and green phosphor process	Cadmium, zinc, suspended solids

Sources: EPA, *Development Documents for Electrical and Electronic Components Phases I and II*, 1983 & 1984; Maag et al., *Assessing the Environmental Impact of Copper CMP*, 2000.

Pollutants Discharged

Table 5-144 lists the pollutants reported to PCS for electrical and electronic component facilities that reported discharges to PCS by major dischargers in 2000. In addition, this table lists the pollutants reported to TRI as discharged directly or for electrical and electronic component facilities that reported to TRI for 2000. This table lists the number of facilities that reported each chemical and the total pounds of chemical discharged to surface waters. Indirect discharging facilities reported transfers to POTWs. Using average POTW removal efficiencies, EPA estimated the amount of pollutant discharged to surface water (see DCN 00618, *Evaluation of RSEI Model Runs*, for more information). Therefore, the TWPE estimates in this table have been adjusted to account for POTW treatment.

Table 5-144. Pollutant Discharges Reported to PCS and TRI

Pollutant Category and Primary Pollutants	PCS (Pounds)	PCS TWPE	TRI (Pounds)	TRI TWPE
All Pollutants	9,094,696	23,714	4,205,438	9,800
Priority	18,612	18,340	6,243	7,372
Silver	786	12,941 (71%)	0	0
Lead	15	34	2,569	5,754 (78%)
Arsenic	642	2,228 (12%)	389	1,349 (18%)
Copper	2,946	1,847 (10%)	206	129
Nonconventional	8,893,786	5,374	4,199,195	2,428
Total Fluoride	145,775	5,102 (95%)	0	0
Manganese			18,957	1,335 (55%)
Ammonia as Nitrogen	73,775	135 (3%)	405,891	611 (25%)
Ethylene Glycol	0	0	186,118	249 (10%)
Nitrogen, Nitrate Total (As N)	0	0	3,441,214	213 (9%)
Conventionals	182,297	1	0	0
BOD ₅	77,341	–	–	–
TSS	74,414	–	–	–
Oil and Grease	30,542	–	–	–

Source: EPA, *PCSLoads2000* and *TRIRelases2000*.

Relative to other industries evaluated, TWPE discharges in PCS and TRI are low. Generally, a few facilities contribute the bulk of the TWPE estimates from both TRI and PCS. For comparison purposes, Tables 5-145 and 5-146 present the TWPE for electrical and electronic component facilities along with the industries reporting the highest discharges in each database. Table 5-145 presents the information reported to PCS and Table 5-146 presents the information reported to TRI. For a description of the derivation of the values in these tables, see the

memorandum in the public docket titled *Description and Results of EPA Methodology to Synthesize Screening Level Results for the Effluent Guidelines Program Plan for 2004*, which is available through Edocket at document number OW-2003-0074-0391.

Table 5-145. Electrical and Electronic Components TWPE Reported to PCS Compared to Industries with the 10 Highest Discharges

40 CFR Part	Point Source Category	PCS-Reported TWPE	PCS Rank
423	Steam Electric Power Generation	2,933,209	1
414	Organic Chemicals, Plastics and Synthetic Fibers	1,805,928	2
422	Phosphate Manufacturing	1,095,321	3
415	Inorganic Chemicals Manufacturing	853,568	4
421	Nonferrous Metals Manufacturing	434,925	5
440	Ore Mining and Dressing	383,560	6
410	Textile Mills	296,601	7
419	Petroleum Refining	198,251	8
455	Pesticide Chemicals Manufacturing, Formulating	178,977	9
418	Fertilizer Manufacturing	116,464	10
469	Electrical and Electronic Components	23,714	17

Table 5-146. Electrical and Electronic Components TWPE Reported to TRI Compared to Industries with the 10 Highest Discharges

40 CFR Part	Point Source Category	TRI-Reported TWPE	TRI Rank
414	Organic Chemicals, Plastics and Synthetic Fibers	7,303,782	1
423	Steam Electric Power Generation	1,856,645	2
421	Nonferrous Metals Manufacturing	978,450	3
430	Pulp, Paper and Paperboard (Phase II)	628,785	4
415	Inorganic Chemicals Manufacturing	624,250	5
429	Timber Products Processing	404,926	6
419	Petroleum Refining	385,347	7
455	Pesticide Chemicals Manufacturing, Formulating	324,393	8
428	Rubber Manufacturing	166,343	9
463	Plastic Molding and Forming	106,189	10
469	Electrical and Electronic Components	9,789	27

5.5.6.4 Treatment Technology and Pollution Prevention

Control of toxic organics is achieved through solvent management. End-of-pipe treatment generally consists of neutralization and precipitation/clarification.

Facilities that manufacture electrical and electronic components use large amounts of ultra-pure water (UPW) in their processes. Since production of UPW is expensive, pollution prevention efforts in this industry have focused on water efficiency and reuse. Table 5-147 presents water conservation and pollution prevention alternatives for this industry.

Table 5-147. Water Conservation and Pollution Prevention Alternatives for the Electrical and Electronic Components Category

Process	Water Conservation/Pollution Prevention Alternatives
Rinsing	<ul style="list-style-type: none"> Evaluate number of rinses and duration based on level of contamination to eliminate unnecessary rinses. Use countercurrent or spray rinsing to improve efficiency. Switch from continuous flow to on-demand rinsing.
Water reclamation/ materials recovery	<ul style="list-style-type: none"> Use membrane technologies (microfiltration, ultrafiltration, reverse osmosis, and electrodialysis) to recycle and recover process water. Recover reusable materials, such as copper and chromium, from process wastewater. Treat spent rinse water at the DI water generating plant and reuse in process.
Once-through cooling	<ul style="list-style-type: none"> Use air-cooled models to eliminate water-usage for single-pass cooling.

Source: Energy and Water Efficiency for Semiconductor Manufacturing, Pacific Northwest Pollution Prevention Resource Center, 2000.

5.5.6.5 Industry Trends

As shown in Table 5-148, U.S. Economic Census data indicate that, between 1992 and 1997, there was an almost 16-percent decrease in the number of electron tube manufacturing facilities and an almost 20-percent increase in the number of facilities manufacturing semiconductors and related devices. Value of goods shipped increased in both sectors, by almost 23 percent for electron tubes and by 144 percent for semiconductors. As shown in Table 5-149, advance comparative statistics for 1997 to 2002 for the broader category represented by NAICS code 334 (facilities that manufacture computer and electronic products) show an almost 10-percent decrease in the number of establishments and a 19-percent decrease in the value of shipments (not adjusted for inflation).

Table 5-148. 1992 and 1997 Census Data

SIC Code	Industry Sector	Number of Establishments			Value of Shipped Goods (billions of dollars)		
		1997	1992	Percent Change	1997	1992	Percent Change
3671	Electron Tubes	159	189	-15.9	3.9	3.1	22.7
3674	Semiconductors & related devices	1,099	920	19.5	0.079	0.032	144

Source: 1997 U.S. Economic Census.

Table 5-149. 1997 and 2002 Census Data

NAICS Code	Industry Segment	Number of Establishments			Value of Goods Shipped (billions of dollars)		
		2002	1997	Percent Change	2002	1997	Percent Change
334	Computer and Electronic Product Manufacture	15,698	17,435	- 9.96	354	439	- 19.4

Source: 2002 U.S. Economic Census.

5.5.6.6 Stakeholder and EPA Regional Issues

This subsection discusses stakeholder and EPA regional issues. EPA primarily received input from stakeholders and EPA Regional staff prior to the Preliminary Effluent Guideline Plan. EPA did not receive any comments to the Preliminary Plan pertaining to the electrical and electronic component industry.

Concerns Identified Pre-Proposal

Several groups surveyed by the Agency in the 2004 annual review provided input on the Electrical and Electronic Components category. Their suggestions are summarized below.

Permitting Authorities (Section 2.5 of the "Factor 4 Analysis: Implementation and Efficiency Considerations - Status of Screening Level Review Phase" (Edocket OW-2003-0074-0329))

EPA permitting authorities suggest that these guidelines need to be revised due to significant changes since they were promulgated. EPA permitting authorities also suggest that the semiconductor manufacturing portion of this industry be evaluated because there have been major changes in the industry. Two new circumstances in this portion of the industry raise concerns: 1) the industry is moving from aluminum to the more toxic copper to build internal components; and 2) the industry is increasingly using new process operations, one of which is

chemical-mechanical planarization (CMP) (a polishing step resulting in the abrasive removal of metals), which generates more or different pollution than the processes considered during the development of the existing ELGS.

EPA appreciates all comments and suggestions provided by the stakeholders and EPA Regional staff. However, as with any comments its receives, EPA cannot address thesesuggestions without adequate supporting data. Information in PCS and TRI does not indicate that electrical and electronic component facilities are discharging significant quantities of copper relative to other industries (Tables 5-150 and 5-151). In the event that stakeholders provide additional data and supporting information on these or any of the issues identified above, EPA will reevaluate them at that time.

Table 5-150. Copper Discharges Reported to TRI by Electrical and Electronic Component Manufacturing Facilities

SIC Code	Sector	# Facilities	Pollutant	Discharge Status	Pounds	TWPE
3671	Electron Tubes	1	Copper Compounds	Direct	31	19
		1	Copper Compounds	Indirect	14	8.6
3674	Semiconductors and Related Devices	1	Copper	Indirect	1.4	0.86
		2	Copper Compounds	Indirect	160	100

Source: EPA, *TRIRelases2000*.

Table 5-151. Copper¹ Discharge Data in PCS for Electrical and Electronic Component Manufacturing Facilities

SIC Code	Sector	# Facilities	Pounds	TWPE
3671	Electron Tubes	1	45	28
3674	Semiconductors and Related Devices	3	2,901	1,819

Source: EPA *PCSLoads2000*.

¹Copper is reported as Copper, Total as Cu.

5.5.6.7 Conclusions

Based on information reported to TRI and PCS, toxic discharges from electrical and electronic component facilities are low relative to other industrial categories. In addition, generally, a few facilities contribute the bulk of the TWPE estimates from both TRI and PCS.

Stakeholders and EPA staff identified various issues associated with discharges from electrical and electronic component facilities. The information in the docket on the 2004 annual review does not at this time support the concerns raised. In the event that stakeholders provide additional data and supporting information during subsequent review cycles, EPA will reevaluate them at that time.

5.5.6.8 References

1. Pendergast, James F. and Sheila E. Frace. *Permitting Guidance for Semiconductor Manufacturing Facilities*. Memorandum to regional water management division directors. April 1998.

5.5.7 Metal Molding and Casting (Part 464)

During the screening-level review phase of the 2004 annual review, metal molding and casting was one of eight industrial categories identified solely through Factor 4 concerns. Issues driving the concerns include: 1) discharges of phenol, 2) changes to the industry since the guidelines promulgated, 3) applicability to aluminum die casters, and 4) discrepancies between limits set for these guidelines and those set for the same pollutants by the guidelines for metal finishing.

5.5.7.1 Industry Description

The Metal Molding and Casting Point Source Category is regulated at 40 CFR Part 464. This point source category includes facilities reporting under SIC industry group 33: Primary Metal Industries, and the subgroups 332: Iron and Steel Foundries and 336: Nonferrous Foundries. Specifically, it includes SIC codes 3321 (Gray and Ductile Iron Foundries), 3325 (Steel Foundries Not Elsewhere Classified), 3364 (Nonferrous Die-Castings, Except Aluminum), 3365 (Aluminum Foundries), 3366 (Copper Foundries), and 3369 (Nonferrous Foundries Except Aluminum and Copper). No specific subcategories were identified during the Factor 4 analysis. Below is a description of the SIC codes for this category:

- SIC code 3321 - *Gray and Ductile Iron Foundries*. Establishments primarily engaged in manufacturing gray and ductile iron castings, including cast iron pressure and soil pipes and fittings.
- SIC code 3322 - *Malleable Iron Foundries*. Establishments primarily engaged in manufacturing malleable iron castings.
- SIC code 3324 - *Steel Investment Foundries*. Establishments primarily engaged in manufacturing steel investment castings.
- SIC code 3325 - *Steel Foundries, Not Elsewhere Classified*. Establishments primarily engaged in manufacturing steel castings, not elsewhere classified.
- SIC code 3364 - *Nonferrous Die-Castings, Except Aluminum*. Establishments primarily engaged in manufacturing nonferrous metal die-castings, except aluminum.

- SIC code 3365 - *Aluminum Foundries*. Establishments primarily engaged in manufacturing aluminum (including alloys) castings, except die-castings.
- SIC code 3366 - *Copper Foundries*. Establishments primarily engaged in manufacturing copper (including alloys) castings, except die-castings.
- SIC code 3369 - *Nonferrous Foundries, Except Aluminum and Copper*. Establishments primarily engaged in manufacturing nonferrous metal castings (including alloys), except all die-castings and other castings of aluminum or copper.

Facility Counts

EPA obtained Information on the number of facilities in the Metal Molding and Casting Point Source Category from three sources: the 1997 U.S. Economic Census, *TRIReleases2000*, and *PCSLoads2000*. TRI includes facilities reporting discharges to any media. In contrast, PCS includes only facilities that are permitted for discharge to surface waters. Table 5-152 lists the number of facilities from these sources.

Table 5-152. Number of Facilities in the Metal Molding and Casting Category

SIC Code	1997 U.S. Economic Census	PCS			TRI				
		Total	Major Dischargers	Minor Dischargers	Total Reporters	No Reported Discharge	Direct Discharge	Indirect Discharge	Both Direct & Indirect
3321	669	31	4	27	200	137	28	22	13
3322	28	4	0	4	8	5	2	1	0
3324	159	2	0	2	43	23	3	10	7
3325	288	8	2	6	99	72	15	8	4
3364	279	6	0	6	20	14	0	6	0
3365	626	14	2	12	74	60	8	4	2
3366	312	0	0	0	72	49	10	8	5
3369	141	6	0	6	58	32	6	14	6

Source: EPA, *PCSLoads2000*, *TRIReleases2000*.

Of the 189 facilities reporting discharges to PCS or TRI, over 50 percent (95) are concentrated in six states: Ohio (21), Pennsylvania (17), Wisconsin (16), Indiana (14), Michigan (14), and Alabama (13). The rest are located in 30 states around the country.

5.5.7.2 Regulatory Background

The current ELGS for the Metal Molding and Casting Point Source Category, 40 CFR Part 465, contain four subcategories (Subparts A - D). Effluent limitations were first proposed November 1982. Final versions of the effluent limitations for Subparts A - D were

promulgated October 30, 1985. EPA established no limitations for the magnesium casting subcategory as the Agency determined they were not achievable economically for existing plants. BCT was reserved for all subparts (A-D). NSPS are equal to BAT; PSNS are equal to PSES.

Effluent limitations guidelines are mass-based on the basis of metric ton (kkg) of metal poured or sand reclaimed, or standard cubic meters (Sm³) of air scrubbed. Limitations were established based on a subcategorization and production process segmentation scheme. Separate limitations were developed for facilities with intermittent or noncontinuous discharge. Table 5-153 presents the 30-day averages for BPT and for BAT/NSPS/PSES/PSNS.

The technology basis of existing regulations is recycle, lime precipitation and sedimentation for BPT and recycle, lime precipitation and sedimentation, and filtration for BAT, NSPS, PSES and PSNS. “No discharge of process wastewater” is the basis of limitations for 3 of the 28 regulated process segments. These processes are the grinding scrubber process for the aluminum, copper, and ferrous casting subparts.

Table 5-153. Effluent Guidelines for Metal Molding and Casting – Continuous Direct Dischargers (kg/kkg)

Pollutant Parameter	BPT 30-day Averages	BAT/NSPS/PSES/PSNS 30-day Averages
TSS	0.13-165	0.104-165 ²
Oil and Grease	0.0864-110	0.0864-110 ²
Total Phenols ¹	0.0026-1.17	0.0026-1.17 ³
Total Toxic Organics	<i>not regulated for BPT</i>	0.0064-8.29 ⁴
Copper	0.036-4.63	0.0036-4.63 ³
Lead	0.0034-4.3	0.0022-4.3 ³
Zinc	0.0037-6.17	0.0025-4.74 ³
pH	7.0-10.0	Not regulated

¹Phenols not regulated at BPT for casting cleaning and quench, investment casting, mold cooling, or slag quench.

²NSPS.

³BAT, NSPS, PSES, PSNS.

⁴PSES and PSNS.

5.5.7.3 Wastewater Characteristics and Pollutant Sources

Most major facilities reporting to PCS report discharge outfall flow rates. Table 5-154 presents the total annual flow (in millions of gallons) for 2000, median annual discharge flow, and the range of annual flows for metal molding and casting facilities. Facilities not reporting a flow were not included in the median calculation. Data presented in Table 5-154 are based on major dischargers reporting to PCS for 2000.

Table 5-154. Wastewater Flows in Metal Molding and Casting

SIC Code	Number of Major Facilities Reporting Nonzero Flows	Median Facility Flow in 2000 (MGY)	Range of Facility Flows in 2000 (MGY)	Total Flow in 2000 (MGY)
3321	4	709	315-7008	8,740
3322	NA	NA	NA	NA
3324	NA	NA	NA	NA
3325	2	431	57-805	862
3364	NA	NA	NA	NA
3365	2	90	89-92	180
3366	NA	NA	NA	NA
3369	NA	NA	NA	NA

Source: EPA, *PCSLoads2000*.

NA - PCS data were not available for the SIC code.

Wastewater pollutant loads from facilities in this industry depend on water usage, type of metal being cast, and the production process used. Suspended solids and metals loading are higher in scrubber wastewaters than in mold cooling wastewaters. Oil and grease and organic priority pollutant loadings are higher in die casting wastewaters than in casting quench wastewaters. A major portion of the wastewater from die casting operations is water used as a carrier solution for oily die casting lubricants. Table 5-155 presents the sources of process wastewater in this category. Approximately 80 percent of the regulated wastewater from this industry is generated by wet air pollution control devices

Table 5-155. Sources of Process Wastewater in Metal Molding and Casting

Process	Wastewater Pollutants
Casting cleaning	Metals, suspended solids, oil and grease, toxic organics
Casting quench	Metals, suspended solids, oil and grease, toxic organics
Die casting	Metals, suspended solids, oil and grease, toxic organics, phenols
Dust collection scrubber	Metals, suspended solids, oil and grease, toxic organics, phenols
Grinding scrubber	Metals, suspended solids, oil and grease, total toxic organics
Investment casting	Metals, suspended solids, oil and grease, toxic organics
Melting furnace scrubber	Metals, suspended solids, oil and grease, toxic organics, phenols
Mold cooling	Metals, suspended solids, oil and grease, toxic organics
Slag quench	Metals, suspended solids, oil and grease, toxic organics
Wet sand reclamation	Metals, suspended solids, oil and grease, toxic organics, phenols

Source: EPA, *Development Document for Effluent Limitations Guidelines and Standards for the Metal Molding and Casting (Foundries) Point Source Category (Final)* (EPA 440-1-85-070), 1985

Pollutants Discharged

Table 5-156 lists the pollutants reported to PCS for metal molding and casting facilities that reported discharges to PCS by major dischargers in 2000. In addition, Table 5-156 lists the pollutants reported to TRI as discharged directly or for metal molding and casting facilities that reported to TRI for 2000. This table presents the number of facilities that reported each chemical and the total pounds of chemical discharged to surface waters. Indirect discharging facilities reported transfers to POTWs. Using average POTW removal efficiencies, EPA estimated the amount of pollutant discharged to surface water (see DCN 00618, *Evaluation of RSEI Model Runs*, for more information). Therefore, the TWPE estimates in this table have been adjusted to account for POTW treatment

Table 5-156. Pollutant Discharges Reported to PCS and TRI

Pollutant Category & Primary Pollutants ¹	PCS (Pounds)	PCS TWPE	TRI (Pounds)	TRI TWPE
All Pollutants	2,253,343	5,834	284,419	45,182
Nonconventionals	2,008,818	561	257,189	31,399
Sodium Nitrite	–	–	78,062	29,143 (93%)
Chlorine, Total Residual	817	398 (71%)	2,600	1,266 (4%)
Molybdenum	517	104 (19%)	–	–
Conventionals	233,663	0	0	0
Oil and Grease	133,461	–	–	–
TSS	91,425	–	–	–
BOD ₅	8,777	–	–	–
Priority	10,862	5,273	27,230	13,783
Lead	1,714	3,840 (73%)	3,173	7,108 (52%)
Polychlorinated Biphenyls	0.053	677 (13%)	–	–
Copper	532	333 (6%)	8,380	5,254 (38%)

¹The majority of each pollutant type is discharged by facilities in SIC code 3321.

Relative to other industries evaluated, TWPE discharges in PCS and TRI are low. Generally, a few facilities contribute the bulk of the TWPE estimates from both TRI and PCS. For comparison purposes, Tables 5-157 and 5-158 present the TWPE for metal molding and casting along with the industries reporting the highest discharges in each database. Table 5-157 presents the information reported to PCS and Table 5-158 presents the information reported to TRI. For a description of the derivation of the values in these tables, see the memorandum in the public docket titled *Description and Results of EPA Methodology to Synthesize Screening Level Results for the Effluent Guidelines Program Plan for 2004*, which is available through Edocket at document number OW-2003-0074-0391.

Table 5-157. Metal Molding and Casting TWPE Reported to PCS Compared to Industries Reporting Highest Discharges

40 CFR Part	Point Source Category	PCS-Reported TWPE	PCS Rank
423	Steam Electric Power Generation	2,933,209	1
414	Organic Chemicals, Plastics and Synthetic Fibers	1,805,928	2
422	Phosphate Manufacturing	1,095,321	3
415	Inorganic Chemicals Manufacturing	853,568	4
421	Nonferrous Metals Manufacturing	434,925	5
440	Ore Mining and Dressing	383,560	6
410	Textile Mills	296,601	7
419	Petroleum Refining	198,251	8
455	Pesticide Chemicals Manufacturing, Formulating	178,977	9
418	Fertilizer Manufacturing	116,464	10
464	Metal Molding and Casting	5,834	26

Source: EPA, *PCSLoads2000*.**Table 5-158. Metal Molding and Casting TWPE Reported to TRI Compared to Industries Reporting Highest Discharges**

40 CFR Part	Point Source Category	TRI-Reported TWPE	TRI Rank
414	Organic Chemicals, Plastics and Synthetic Fibers	7,303,782	1
423	Steam Electric Power Generation	1,856,645	2
421	Nonferrous Metals Manufacturing	978,450	3
430	Pulp, Paper and Paperboard (Phase II)	628,785	4
415	Inorganic Chemicals Manufacturing	624,250	5
429	Timber Products Processing	404,926	6
419	Petroleum Refining	385,347	7
455	Pesticide Chemicals Manufacturing, Formulating	324,393	8
428	Rubber Manufacturing	166,343	9
463	Plastic Molding and Forming	106,189	10
464	Metal Molding and Casting	45,173	16

Source: EPA, *TRIRelases2000*.

5.5.7.4 Treatment Technology and Pollution Prevention

Standard treatment may include chemical precipitation and sedimentation, oil removal, and filtration. Pollution prevention activities focus on reducing waste sand, waste electric arc furnace dust and desulfurization slag, and increasing energy efficiency. Table 5-159 presents water conservation and pollution prevention alternatives for this industry.

Table 5-159. Water Conservation and Pollution Prevention Alternatives for the Metal Molding and Casting Category

Processes To Reduce	Water Conservation/Pollution Prevention Alternatives
Solid Waste or Air Pollution	<ul style="list-style-type: none"> • Use vacuum molding, which holds the sand in the shape of the pattern after pattern is removed. No shakeout equipment required and almost no waste sand is generated. • Reclaim and reuse waste sand and metal through waste segregation, screening, dry scrubbing, or thermal reclamation. • Improve furnace efficiency. • Install induction furnaces, which are 75-80% energy efficient and emit 75% less dust and fumes. • Minimize metal melting by reducing excess melted metal. • Use alternative furnace fuels (e.g., natural gas, lower grade/low sulfur or low nitrogen fuel-oil). • Maintain furnaces properly to reduce air emissions. • Recycle electric arc furnace (EAF) dust to original process or reuse outside original process. • Use charge material containing lower concentrations of lead, zinc, and cadmium (e.g., charge modification program to develop reliable sources of high-grade scrap metal). • Minimize hazardous desulfurizing slag (e.g., alternative desulfurization agents).
Water Uses and/or Water Pollution	<ul style="list-style-type: none"> • Reduce phenols by substituting synthetic oils or water-based materials, segregating waste streams at point of generation. • Use cooling water recycling systems. • Optimize deburring operations to minimize total suspended solids. • Use fewer additives, such as biocides, or additives containing no VOCs or HAPs. • Use alternative die lubricants.

Source: OECA Sector Notebook: Profile of the Metal Casting Industry, 1998.

5.5.7.5 Industry Trends

As shown in Table 5-160, U.S. Economic Census data indicate an overall increase in the number of metal molding facilities between 1992 and 1997. Value of goods shipped has also increased by 15 percent or more for bituminous coal during the same time period. As shown in Table 5-161, advance comparative statistics for 1997 to 2002 for NAICS code 331 (industries that smelt and/or refine metals using electrometallurgical processes) show a 17.6-percent increase in the number of establishments and a 19-percent decrease in the value of shipments (not adjusted for inflation).

Table 5-160. 1992 and 1997 Census Data

SIC Code	Industry Sector	Number of Establishments			Value of Goods Shipped (billions of dollars)		
		1997	1992	Percent Change	1997	1992	Percent Change
3321	Gray and Ductile Iron Foundries	669	709	-6	11.9	7.7	53
3322	Malleable Iron Foundries	28	24	17	0.35	0.25	42
3324	Steel Investment Foundries	159	152	5	2.3	1.7	35
3325	Steel Foundries, Not Elsewhere Classified	288	287	0.3	2.9	2.1	40
3364	Nonferrous Die-Casting, Except Aluminum	279	263	6	2.0	1.0	101
3365	Aluminum foundries	626	591	6	3.9	1.9	101
3366	Copper Foundries	312	329	-5	0.86	0.74	15
3369	Nonferrous Foundries, Except Aluminum & Copper	141	119	19	0.96	0.46	109

Source: 1997 U.S. Economic Census.

Table 5-161. 1997 and 2002 Census Data

NAICS Code	Industry Segment	Number of Establishments			Value of Goods Shipped (billions of dollars)		
		2002	1997	Percent Change	2002	1997	Percent Change
331	Primary Metal Manufacturing	5,952	5,059	17.6	136	168	-19

Source: 2002 U.S. Economic Census.

5.5.7.6 Stakeholder and EPA Regional Issues

This subsection discusses stakeholder and EPA Regional issues. EPA primarily received input from stakeholders prior to the Preliminary Effluent Guidelines Plan. EPA received one comment on the Preliminary Plan pertaining to the metal molding and casting industry. This commenter expressed concern that the final regulation and technical development document had inconsistencies. However, the commenter did not provide any specifics on these inconsistencies.

Concerns Identified Pre-Proposal

Several groups surveyed by the Agency in the 2004 annual review provided input on the Metal Molding and Casting category. Their suggestions are summarized below.

Comments on the Draft Strategy (Section 2.2 of the “Factor 4 Analysis: Implementation and Efficiency Considerations - Status of Screening Level Review Phase” (Edocket OW-2003-0074-0329))

A stakeholder asserts that the effluent guidelines should be reevaluated to address the discrepancy of metals limits between this category and those in the Metal Finishing ELGS. The ELGS for the Metal Molding and Casting category are production-based, and when the appropriate values are applied and calculations performed to convert these into equivalent concentration limits, the resulting discharge limits for metals are orders of magnitude lower than the metal finishing ELGS. This suggests there is a problem either with the metal finishing regulations (which EPA recently reviewed during development of the MP&M regulation development) or ELGS for the Metal Molding and Casting category.

Previous Suggestions (Section 2.4 of the “Factor 4 Analysis: Implementation and Efficiency Considerations - Status of Screening Level Review Phase” (Edocket OW-2003-0074-0329))

Specific activities of concern identified by responders include fastener manufacturing, job shop galvanizers, and jewelry manufacturing. Phenol was identified as a pollutant of concern.

Permitting Authorities (Section 2.5 of the “Factor 4 Analysis: Implementation and Efficiency Considerations - Status of Screening Level Review Phase” (Edocket OW-2003-0074-0329))

EPA permitting authorities have found cyanide to be an issue when molten slag is allowed to come into contact with the quench water in the quenching process. EPA permitting authorities also identified the following concerns with implementing the guidelines for the aluminum die casters subcategory: 1) the ELGS are confusing (e.g., the applicability of the regulations cover only part of the casting process); 2) the ELGS should allow permit writers to determine additional fundamentally different factors (FDF); and 3) permit writers have problems calculating limits attainable by permitted facilities using the formulas provided in the guidelines (specifically for total phenols and oil and grease). Expanding on this last item, EPA permitting authorities explain that the building-block method for determining allowances, when applied to small facilities, results in a low limit on total phenols. EPA permitting authorities assert that it is difficult to find a technology to meet these low limits, resulting in a number of facilities being unable to meet a limit that was neither reasonable nor necessary to protect the POTW. Although protecting POTWs is not one of the 304(m) evaluation criteria, EPA permitting authorities note that the resulting noncompliance forces control authorities to choose between escalating

enforcement actions for a relatively minor infraction or ignoring the violation if they are convinced that all reasonable efforts have been made to meet the limits. Possible solutions to the problem could include: 1) using production as a limiting factor to provide relief to smaller facilities, and 2) allowing control authorities to apply concentration-based standards, similar to the approach used in Porcelain Enameling (40 CFR Part 466). Permitting authorities also asserted that EPA removed the phenol limits from the pretreatment standards of the Organic Chemicals, Plastics, and Synthetic Fibers effluent guidelines (40 CFR Part 414) after finding that phenol did not pass through POTWs (i.e., indirect dischargers do not need to meet stringent phenol limits).

AMSA and ASIWPCA (Section 2.6 of the “Factor 4 Analysis: Implementation and Efficiency Considerations - Status of Screening Level Review Phase” (Edocket OW-2003-0074-0329))

ASIWPCA stakeholders identified several effluent guidelines that are out of date relative to available technology, including those for metal molding and casting.

Additional Concerns Identified Post-Proposal

In addition, in an e-mail collection of suggestions, four state pretreatment coordinators discussed implementation and efficiency issues. One coordinator noted that having die casting limits based on production results in a lot of small shops often being out of compliance because they can't meet the limits at their low production volumes. A second coordinator reported that die casters have constant problems with the total phenols and oil and grease limits. During follow-up discussions, an additional pretreatment coordinator explained that the problem usually occurs in small facilities where their only allowance for phenol came from the tiny amount provided for die casting, which is insufficient to account for background levels of phenol.

Another coordinator noted that casting cleaning operations (listed in the aluminum casting and ferrous casting subcategories) does not occur and cannot occur given the definitions and conditions of the regulation. All subcategories have a casting quench operation, but the definitions make it clear that the standard applies only to precooling operations. Because of the way the definitions are written at 464.02 (a) “Aluminum Casting” and 464.02 (b) “Ferrous Casting,” cleaning operations are not captured by the regulation. A simple solution is to correct the general definitions, as suggested below. Another option is to eliminate the allocations for casting cleaning from these subcategories since it applies to an operation that cannot exist under this regulation the way it is written.

For the aluminum casting definition, insert the underlined text “Processing operations following the cooling of castings not covered under aluminum forming, except for grinding scrubber operations and casting cleaning operations, which are covered here, are covered under electroplating and metal finishing point source categories (40 CFR Part 413 & 433).” For the ferrous casting definition, insert the underlined text “Except for grinding scrubber

operations and casting cleaning operations which are covered here, processing operations following the cooling of castings are covered under electroplating and metal finishing point source categories (40 CFR Part 413 & 433).”

A fourth coordinator noted that in the aluminum forming subcategory, production standards result in extremely low permit limits. Whenever production changes by as little as 20 percent, permit limits have to be changed accordingly. Concentration-based standards would save the endless modification and the associated administrative burden. It also seems inconsistent to require metal finishers to discharge a pollutant at the ppm level while the production based industry is required to meet a ppb level.

EPA appreciates all comments and suggestions provided by the stakeholders and EPA Regional staff. However, as with any comments it receives, EPA cannot address these suggestions without adequate supporting data. Some stakeholders noted that metal molding and casting limitations are often more stringent than metal finishing limitations. EPA notes that limitations and standards for each industrial category consider the best available technology economically achievable for a particular subcategory of a particular industry. As a result of differences in wastewater characteristics, treatment and pollution prevention technologies, and economic considerations, limitations vary from one industrial category to the next. In the event that stakeholders provide additional data and supporting information, on these or any of the issues identified above, EPA will reevaluate them at that time. EPA notes that in some cases commenters raised implementation issues rather than guideline revision issues. EPA will continue to consider implementation issues raised by these stakeholders.

5.5.7.7 Conclusions

Based on information reported to TRI and PCS, toxic discharges from metal molding and casting facilities are low relative to other industrial categories. In addition, generally, a few facilities contribute the bulk of the TWPE estimates from both TRI and PCS.

Stakeholders and EPA staff identified various issues associated with discharges from metal molding and casting facilities. The information in the docket on the 2004 annual review does not at this time support the concerns raised. In the event that stakeholders provide additional data and supporting information during subsequent review cycles, EPA will reevaluate them at that time.

5.5.8 **Mineral Mining and Processing (Part 436)**

During the screening-level review phase of the 2004 annual review, mineral mining and processing was one of eight industrial categories identified solely through Factor 4 concerns. Issues driving the concerns include: 1) pollutants not covered by the guidelines (specifically TSS), and 2) consistent application of the guidelines by permit writers.

5.5.8.1 Industry Description

The Mineral Mining Point Source Category is regulated at 40 CFR Part 436. This point source category includes facilities reporting under two SIC industry groups: 14 – Mining and Quarrying of Nonmetallic Minerals, except fuels, and 32 – Stone Clay, Glass, and Concrete Products. See Attachment C for the applicability and regulatory background. Specifically, the category includes SIC codes 1422 (Crushed and broken limestone), 1442 (Construction sand and gravel), 1459 (Clay, ceramic, and refractory minerals not elsewhere classified), 1475 (Phosphate rock), 1479 (Chemical and fertilizer mineral mining not elsewhere classified), 1481 (Nonmetallic minerals services, except fuels), and SIC 3295 (Minerals and Earths, Ground or Otherwise Treated). All of these SIC codes are represented by dischargers reporting to the PCS but not TRI. It also includes SIC code 3275 (Gypsum Products), which was reported in PCS and was the *only* SIC code represented in the TRI. No specific subcategories were identified during the Factor 4 analysis; however, two subcategories were discussed in comments on the Preliminary Plan: Crushed Stone Subcategory B (40 CFR Part 436.20), and Construction Sand and Gravel Subcategory C (40 CFR Part 436.30), covered by SIC 1442.

- SIC code 1411 - *Dimension Stone*. Establishments primarily engaged in mining or quarrying dimension stone. Also included are establishments engaged in producing rough blocks and slabs. Establishments primarily engaged in mining dimension soapstone or in mining or quarrying and shaping grindstones, pulpstones, millstones, burrstones, and sharpening stones are classified in SIC code 1499. Establishments primarily engaged in dressing (shaping, polishing, or otherwise finishing) blocks and slabs are classified in Manufacturing, SIC code 3281. Nepheline syenite mining operations are classified in SIC code 1459.
- SIC code 1422 - *Crushed and Broken Limestone*. Establishments primarily engaged in mining or quarrying crushed and broken limestone, including related rocks, such as dolomite, cement rock, marl, travertine, and calcareous tufa. Also included are establishments primarily engaged in the grinding or pulverizing of limestone, but establishments primarily engaged in producing lime are classified in Manufacturing, SIC code 3274.
- SIC code 1423 - *Crushed and Broken Granite*. Establishments primarily engaged in mining or quarrying crushed and broken granite, including related rocks, such as gneiss, syenite, and diorite.
- SIC code 1429 - *Crushed and Broken Stone, Not Elsewhere Classified*. Establishments primarily engaged in mining or quarrying crushed and broken stone, not elsewhere classified.

- SIC code 1442 - *Construction Sand and Gravel*. Establishments primarily engaged in operating sand and gravel pits and dredges, and in washing, screening, or otherwise preparing sand and gravel for construction uses.
- SIC code 1446 - *Industrial Sand*. Establishments primarily engaged in operating sand pits and dredges, and in washing, screening, and otherwise preparing sand for uses other than construction, such as glassmaking, molding, and abrasives.
- SIC code 1455 - *Kaolin and Ball Clay*. Establishments primarily engaged in mining, milling, or otherwise preparing kaolin or ball clay, including china clay, paper clay, and slip clay.
- SIC code 1459 - *Clay, Ceramic, and Refractory Minerals, Not Elsewhere Classified*. Establishments primarily engaged in mining, milling, or otherwise preparing clay, ceramic, or refractory minerals, not elsewhere classified.
- SIC code 1474 - *Potash, Soda, and Borate Minerals*. Establishments primarily engaged in mining, milling, or otherwise preparing natural potassium, sodium, or boron compounds. Establishments primarily engaged in mining common salt are classified in SIC code 1479.
- SIC code 1475 - *Phosphate Rock*. Establishments primarily engaged in mining, milling, drying, calcining, sintering, or otherwise preparing phosphate rock, including apatite. Establishments primarily engaged in the production of phosphoric acid, super-phosphates, or other manufactured phosphate compounds or chemicals are classified in manufacturing, SIC major group 28.
- SIC code 1479 - *Chemical and Fertilizer Mineral Mining, Not Elsewhere Classified*. Establishments primarily engaged in mining, milling, or otherwise preparing chemical or fertilizer mineral raw materials, not elsewhere classified. Establishments primarily engaged in milling, grinding, or otherwise preparing barite not in conjunction with mining or quarry operations are classified in Manufacturing, SIC code 3295; similar establishments preparing other minerals of this industry are included here. Establishments primarily engaged in producing salt by evaporation of sea water or brine are classified in Manufacturing, SIC code 2899.
- SIC code 1481 - *Nonmetallic Minerals Services, Except Fuels*. Establishments primarily engaged in the removal of overburden, strip mining, and other services for nonmetallic minerals, except fuels, for others on a contract or fee basis. Establishments primarily engaged in

performing hauling services are classified in Division E, Transportation and Public Utilities.

- SIC code 1499 - *Miscellaneous Nonmetallic Minerals, Except Fuels*. Establishments primarily engaged in mining, quarrying, milling, or otherwise preparing nonmetallic minerals, except fuels. This industry includes the shaping of natural abrasive stones at the quarry. Establishments primarily engaged in the production of blast, grinding, or polishing sand are classified in SIC code 1446, and those calcining gypsum are classified in Manufacturing, SIC code 3275.
- SIC code 3275 - *Gypsum Products*. Establishments primarily engaged in manufacturing plaster, plasterboard, and other products composed wholly or chiefly of gypsum, except articles of plaster of paris and papier-mache.
- SIC code 3295 - *Minerals and Earths, Ground or Otherwise Treated*. Establishments operating without a mine or quarry and primarily engaged in crushing, grinding, pulverizing, or otherwise preparing clay, ceramic, and refractory minerals; barite; and miscellaneous nonmetallic minerals, except fuels. These minerals are the crude products mined by establishments of Industry Groups 145 and 149, and by those of SIC code 1479 mining barite. Also included are establishments primarily crushing slag and preparing roofing granules. The beneficiation or preparation of other minerals and metallic ores, and the cleaning and grading of coal, are classified in Division B, Mining, whether or not the operation is associated with a mine.

Facility Counts

EPA obtained information on the number of facilities in the Mineral Mining Point Source Category from three sources: the 1997 U.S. Economic Census, *TRIRelases2000*, and *PCSLoads2000*. TRI includes facilities reporting discharges to any media. In contrast, PCS includes only facilities that are permitted for discharge to surface waters. Table 5-162 lists the number of facilities from these sources.

Table 5-162. Number of Facilities

SIC Code ¹	1997 Economic Census	PCS			TRI				
		Total	Major Dischargers	Minor Dischargers	Total	No Reported Discharge	Direct Discharge	Indirect Discharge	Both Direct and Indirect
1411	178	8	0	8	0	0	0	0	0
1422	1435	173	6	167	0	0	0	0	0
1423	290	14	0	14	0	0	0	0	0
1429	459	39	0	39	0	1	0	0	0
1442	2367	139	4	135	1	1	0	0	0
1446	140	17	0	17	0	0	0	0	0
1455	35	7	0	7	0	0	0	0	0
1459	132	23	3	20	0	0	0	0	0
1474	27	2	0	2	0	0	0	0	0
1475	20	22	18	4	0	0	0	0	0
1479	45	9	3	6	0	0	0	0	0
1481	172	1	1	0	0	0	0	0	0
1499	216	34	0	34	0	0	0	0	0
3275	208	11	0	11	18	17	1	0	0
3295	388	31	0	31	50	44	3	1	2

Source: PCSLoads2000, TRIRelases2000.

¹Facilities in SIC code 14, (Mining and Quarrying of Nonmetallic Minerals Except Fuels) are not required to report to TRI. Facilities in SIC codes 3275 and 3295 that meet the employee requirements and chemical use thresholds are required to report.

Of the 42 reporting facilities, 48 percent (20) are located in Florida. Another 17 percent (7) are located in Michigan. The rest are located in Alabama, Arizona, Georgia, Missouri, North Carolina, South Carolina, New York, Ohio and Wisconsin.

5.5.8.2 Regulatory Background

The current ELGS for the Mineral Point Source Category, 40 CFR Part 436, contain 38 subcategories (Subparts A - AL). Interim final regulations were published on October 16, 1975 for Subparts E, F, G, J, K, L, N, O, S, V, W, X, Y, Z, AF, and AL. Proposed regulations were issued June 10, 1976 for Subparts B, C, D, E, F, G, J, K, L, M, N, O, R, S, V, W, X, Y, Z, AF, and AL. The effluent limitations for Subparts B, C, D, and R were promulgated July 1979. National amendments were made to the effluent guidelines on December 28, 1979.

Limitations for BAT are the same as for BPT for all subcategories except industrial sand HF flotation; rock salt; sulphur (frash process, salt dome operations); feldspar flotation; and talc (heavy media and flotation). Limitations for NSPS are the same as for BAT. EPA established no requirements for PSES or PSNS.

The following processes are required to achieve no discharge of process-generated wastewater pollutants to navigable waters:

- A. Dimension Stone;
- B. Crushed Stone (dry process only);
- C. Construction Sand and Gravel (dry process only);
- D. Industrial Sand (dry process only);
- E. Gypsum;
- F. Asphaltic Minerals:
 - Bituminous limestone,
 - Oil impregnated diatomite, and
 - Gilsonite;
- G. Asbestos and Wollastonite;
- H. Lightweight Aggregates:
 - Perlite,
 - Pumice, and
 - Vermiculite;
- I. Mica and Sericite:
 - Mica and sericite (dry process),
 - Mica (wet process, grinding process), and
 - Mica (wet beneficiation process);
- J. Barite (dry process only);
- K. Fluorspar (heavy media separation process only);
- M. Borax;
- N. Potash;
- O. Sodium Sulfate;
- P. Trona;
- S. Sulfur (anhydrite only);
- T. Mineral Pigments;
- V. Bentonite;
- W. Magnesite;
- X. Diatomite;
- Y. Jade;
- Z. Novaculite;
- AA. Fire Clay;
- AB. Fuller's Earth (montmorillonite and attapulgitite);
- AC. Kyanite;
- AD. Shale and Common Clay;
- AE. Aplite;
- AF. Tripoli;
- AG. Kaolin (general purpose grade);
- AH. Ball Clay;
- AI. Feldspar (nonflotation processes); and
- AJ. Talc Group (dry and washing processes).

The concentration-based limitations presented in Table 5-163 apply to discharges from wet processes, flotation processes, mine dewatering, and dredging for the crushed stone,

construction sand and gravel, and industrial sand subcategories of 40 CFR Part 436. Dry processes for these subcategories are required to achieve no discharge of process wastewater. Table 5-164 presents concentration-based limits for other subcategories of Part 436.

Table 5-163. Effluent Guidelines for Crushed Stone, Construction Sand and Gravel, and Industrial Sand Subcategories of Part 436

Parameter	BPT 30-day Averages (mg/L)	BPT Daily Maximum (mg/L)
TSS ¹	25	45
pH	within range of 6 to 9	within range of 6 to 9

¹BPT limits for industrial sand HF flotation for TSS are 0.023kg/kkg (monthly avg) and 0.046 kg/kkg (daily maximum), and 0.003 kg/kkg (monthly avg) and 0.006 kg/kkg (daily maximum) for fluoride. BAT requires no discharge.

Table 5-164. Effluent Guidelines for Other Subcategories of Part 436¹

Parameter	BPT 30-day Averages (mg/L)	BPT Daily Maximum (mg/L)
TSS	10 to 50	20 to 100
Total iron ²	1 to 3.5	2 to 7
Sulfide ³	1 to 5	2 to 10
Zinc ⁴	0.25	0.50

¹Subcategories include barite mine dewatering, phosphate rock, sulfur (frash, salt dome operations), fire clay acid mine drainage, kaoline (wet process), talc (mine dewatering), and graphite.

²Total iron limits for barite mine dewatering, fire clay acid mine drainage, and graphite only.

³Sulfide limits for sulfur (frash, salt dome operations) only. BAT limits for sulfur are 1 to 2 mg/L (monthly avg) and 2 to 4 mg/L (daily maximum).

⁴Zinc limits for kaolin wet processing only.

The limitations guidelines in Table 5-165 are normalized on the basis of metric ton (kkg) of raw material.

Table 5-165. Normalized Effluent Guidelines for Subcategories of Part 436¹

Parameter	BPT 30-day Averages (kg/kkg)	BPT Daily Maximum (kg/kkg)
TSS ^{2,3}	0.02 to 1.5	0.04 to 3.0
Fluoride ⁴	0.175	0.35
Dissolved fluoride ⁵	0.2	0.4

¹Subcategories include feldspar floatation; talc, steatite, soapstone, and pyrophyllite (heavy media separation and floatation); mica wet beneficiation process (ceramic grade clay by-product); fluorspar floatation; and rock salt.

²BAT limits for TSS for talc (heavy media and floatation) are 0.3 kg/kkg (monthly avg) and 0.6 kg/kkg (daily maximum).

³BAT limits for TSS for rock salt are 0.002 kg/kkg (monthly avg) and 0.004 kg/kkg (daily maximum).

⁴Fluoride limits for feldspar floatation only. BAT limits for fluoride are 0.13 kg/kkg (monthly avg) and 0.26 (daily maximum).

⁵Dissolved fluoride limits for fluorspar floatation only.

5.5.8.3 Wastewater Characteristics and Pollutant Sources

Most major facilities reporting to PCS report discharge pipe flow rates. Table 5-166 presents the total annual flow (in millions of gallons) for 2000, median annual discharge flow, and the range of annual flows for mineral mining facilities. Facilities not reporting a flow were not included in the median calculation. Data presented in Table 5-166 are based on major dischargers reporting to PCS for 2000.

Table 5-166. Wastewater Flows

SIC Code	Number of Major Facilities Reporting Nonzero Flows	Median Facility Flow In 2000 (MGY)	Range of Facility Flows In 2000 (MGY)	Total Flow In 2000 (MGY)
1422	5	2,644.20	913-8499	19,175.60
1442	3	1,334.96	2-3291	4,628.54
1459	3	241.49	100-950	1,291.73
1475	15	429.20	3-3072	10,839.13
1479	2	8,845.50	8,044-9,647	17,691.00
1481	1	4,802.40	NA	4,802.40

Source: EPA, *PCSLoads2000*.

NA - No range was calculated because only one facility reported a nonzero flow.

Wastewater quantities and content vary day to day, and are affected by rainfall and exposure to surface and underground water. Composition of the wastewater depends on the mineral being mined and the raw materials required for processing. The most important pollutant parameter for this industry is suspended solids.

Many facilities achieve zero discharge by recycling wastewater through the process. Most facilities use settling ponds to control TSS. Aside from pH adjustment, chemical treatment is not common for this industry.

There are three major classifications of wastewater from mining operations:

- Mine dewatering;
- Process water; and
- Rain water runoff.

Process wastewater includes water used to transport minerals from one operation to another, water used in separation processes such as flotation and heavy media separation, air pollution control, and dust control. The pollutants of concern for mineral mining wastewater are suspended and dissolved solids. Table 5-167 presents sources of wastewater for each step of the mining process.

Table 5-167. Process Sources of Wastewater

Mining Process	Wastewater
Mineral Extraction	Surface runoff, groundwater seepage
Mineral Transportation	Transport water
Mineral Processing	Transport water, wash water, dust control water, classification water, heavy media separation water, flotation water, solution water, air emissions control water, floor wash down

Source: Sector Notebook for Non-Fuel, Non-Metal Mining, 1995.

Pollutants Discharged

Table 5-156 lists the pollutants reported to PCS for mineral mining facilities that reported discharges to PCS by major dischargers in 2000. In addition, Table 5-168 lists the pollutants reported to TRI as discharged directly or for mineral mining facilities that reported to TRI for 2000. This table presents the number of facilities that reported each chemical and the total pounds of chemical discharged to surface waters. Indirect discharging facilities reported transfers to POTWs. Using average POTW removal efficiencies, EPA estimated the amount of pollutant discharged to surface water (see DCN 00618, *Evaluation of RSEI Model Runs*, for more information). Therefore, the TWPE estimates in this table have been adjusted to account for POTW treatment.

Table 5-168. Pollutant Discharges Reported to PCS and TRI

Pollutant Category and Primary Pollutants	PCS (Pounds)	PCS TWPE	TRI (Pounds)	TRI TWPE
All Pollutants	95,892,593	29,402	479,076	1,137
Nonconventionals	91,767,088	28,215	477,573	109
Total Dissolved Solids	67,076,047	0	0	0
Total Fluoride	759,269	26,574	0	0
Barium	0	0	17,793	35
Nitrogen, Nitrate Total (As N)	32	0	443,398	27
Conventionals	4,116,305	0	0	0
Total Suspended Solids	4,082,539	99%	–	–
Oil and Grease	33,766	1%	–	–
Priority	9,200	1,187	1,503	1,029
Lead	200	449	184	412
Zinc	8,764	410	312	15
Copper	100	63	750	470
Chromium	0	0	257	132

Source: EPA, PCSLoads2000 and TRIRelases2000.

Relative to other industries evaluated, TWPE discharges reported in PCS and TRI are low. Generally, a few facilities contribute the bulk of the TWPE estimates from both TRI and PCS. For comparison purposes, Tables 5-169 and 5-170 present the TWPE for mineral mining along with the industries reporting the highest discharges in each database. Table 5-169 presents the information reported to PCS and Table 5-170 presents the information reported to TRI. For a description of the derivation of the values in these tables, see the memorandum in the public docket titled *Description and Results of EPA Methodology to Synthesize Screening Level Results for the Effluent Guidelines Program Plan for 2004*, which is available through Edocket at document number OW-2003-0074-0391.

Table 5-169. Mineral Mining TWPE Reported to PCS Compared to Industries Reporting Highest Discharges

40 CFR Part	Point Source Category	PCS-Reported TWPE	PCS Rank
423	Steam Electric Power Generation	2,933,209	1
414	Organic Chemicals, Plastics and Synthetic Fibers	1,805,928	2
422	Phosphate Manufacturing	1,095,321	3
415	Inorganic Chemicals Manufacturing	853,568	4
421	Nonferrous Metals Manufacturing	434,925	5

Table 5-169 (Continued)

40 CFR Part	Point Source Category	PCS-Reported TWPE	PCS Rank
440	Ore Mining and Dressing	383,560	6
410	Textile Mills	296,601	7
419	Petroleum Refining	198,251	8
455	Pesticide Chemicals Manufacturing, Formulating	178,977	9
418	Fertilizer Manufacturing	116,464	10
436	Mineral Mining	29,402	15

Source: EPA, *PCSLoads2000*.**Table 5-170. Mineral Mining TWPE Reported to TRI Compared to Industries Reporting Highest Discharges**

40 CFR Part	Point Source Category	TRI-Reported TWPE	TRI Rank
414	Organic Chemicals, Plastics and Synthetic Fibers	7,303,782	1
423	Steam Electric Power Generation	1,856,645	2
421	Nonferrous Metals Manufacturing	978,450	3
430	Pulp, Paper and Paperboard (Phase II)	628,785	4
415	Inorganic Chemicals Manufacturing	624,250	5
429	Timber Products Processing	404,926	6
419	Petroleum Refining	385,347	7
455	Pesticide Chemicals Manufacturing, Formulating	324,393	8
428	Rubber Manufacturing	166,343	9
463	Plastic Molding and Forming	106,189	10
436	Mineral Mining	1,137	33

Source: EPA, *TRIRelases2000*.

5.5.8.4 Treatment Technology and Pollution Prevention

Solids Removal

The predominant treatment technique for solids removal is settling ponds. Other treatment technologies that may be used include flocculation, filters, clarifiers, and thickeners.

Neutralization/Chemical Precipitation

This treatment technology is often used to remove dissolved solids such as fluoride, iron, sulfides, and zinc.

Recycle

Facilities recycle settled wastewater to the process.

Pollution Prevention

Table 5-171 lists water conservation and pollution prevention alternatives for this industry.

Table 5-171. Water Conservation and Pollution Prevention Alternatives

Process	Water Conservation/Pollution Prevention Alternatives
Surface runoff	Use diversion systems to channel runoff away from exposed mine pits and waste dumps.
Dust control	Reuse contaminated wastewater for dust elimination in the mineral extraction process.
Groundwater seepage	Use subsurface drainage systems and barriers to collect or deflect groundwater prior to contact with exposed mine pits.

Source: Sector Notebook for Non-Fuel, Non-Metal Mining, 1995.

5.5.8.5 Industry Trends

U.S. Economic Census data presented in Table 5-172 illustrates industry trends in number of establishments and value of goods shipped between 1992 and 1997. Depending on the sector, changes in the number of establishments range from a 36-percent increase to a 36-percent decrease. The change in the value of good shipped also varied by sector, and in general increased.

NAICS code 212 covers mining (except oil and gas) of metallic minerals and nonmetallic minerals, including coal. As shown in Table 5-173, advance comparative statistics for 1997 to 2002 for NAICS code 212 show a 2-percent decrease in the number of establishments and a 6-percent increase in the value of shipments (not adjusted for inflation).

Table 5-172. 1992 and 1997 Census Data

SIC Code	Industry Segment	Number of Establishments			Value of Goods Shipped (billions of dollars)		
		1997	1992	Percent Change	1997	1992	Percent Change
1411	Dimension Stone	178	NA	NA	0.13	0.10	27.0
1422	Crushed and Broken Limestone	1,435	1,322	8.5	4.5	3.2	40.7
1423	Crushed and Broken Granite	290	247	17.4	1.5	0.90	69.0
1429	Crushed and Broken Stone, NEC.	459	428	7.2	1.3	0.93	35.5
1442	Construction Sand and Gravel	2,367	2,430	-2.6	3.5	2.8	26.2
1446	Industrial Sand	140	149	-6.0	0.51	0.41	24.5
1455	Kaolin and Ball Clay	35	NA	NA	0.94	0.78	20.3
1459	Clay, Ceramic, and Refractory Minerals, NEC.	132	148	-10.8	0.619	0.620	0.1
1474	Potash, Soda, and Borate Minerals	27	NA	NA	1.7	1.5	12.4
1475	Phosphate Rock	20	NA	NA	1.0	1.2	-14.5
1479	Chemical and Fertilizer Mineral Mining, NEC.	45	70	-35.7	0.36	0.42	-14.5
1481	Nonmetallic Minerals Services, Except Fuels	172	NA	NA	0.191	0.189	1.1
1499	Misc. Nonmetallic Minerals, Except Fuels	216	270	-20.0	0.632	0.596	6.0
3275	Gypsum Products	208	153	35.9	4.4	2.1	109.0

Source: 1997 U.S. Economic Census.

NA - Comparable data were not available.

Table 5-173. 1997 and 2002 Census Data

NAICS Code	Industry Segment	Number of Establishments			Value of Goods Shipped (billions of dollars)		
		2002	1997	Percent Change	2002	1997	Percent Change
212	Mining (except oil & gas)	7,173	7,348	-2	54	51	6

Source: 2002 U.S. Economic Census.

5.5.8.6 Stakeholder and EPA Regional Issues

This section discusses stakeholder and EPA Regional issues. EPA primarily received input from stakeholders prior to the Preliminary Effluent Guidelines Plan. In addition, EPA received comments on the Preliminary Plan asserting that the existing ELGS are adequate.

Concerns Identified Pre-Proposal

Several groups surveyed by the Agency in the 2004 annual review provided input on the Mineral Mining and Processing category. Each group and their suggestions are summarized below.

Previous Suggestions (Sec. 2.4 of the “Factor 4 Analysis: Implementation and Efficiency Considerations - Status of Screening Level Review Phase” (Edocket OW-2003-0074-0329))

Responders suggested the need for more complete ELGS, including the addition of TSS limits, and were concerned that the existing guidelines are inconsistently applied.

Concerns Identified in Comments to Proposal

For the crushed stone subcategory and the construction sand and gravel subcategory, a commenter asserted that the existing effluent guidelines established by the EPA for the aggregates industry are adequate. The pollutants discharged from aggregate operations are limited, and no new processes have developed within the aggregates industry over the past several decades that would increase the amount of pollutants discharged. These conclusions are supported by the findings of two reports that indicate that the existing guidelines are adequate: 1) the National Stone Association (NSA) April 1993 report, *An Analysis of the EPA Effluent Guidelines and Standards For the Mineral Mining Industrial Category as Related to the Requirements of the EPA NPDES Storm Water Regulations* and 2) U.S. EPA’s June 1982 report from the Office of Water & Waste Management, *The Effects of Discharges from Limestone Quarries on Water Quality and Aquatic Biota*.

EPA appreciates all comments and suggestions provided by the stakeholders and EPA Regional staff. However, as with any comments it receives, EPA cannot address these suggestions without adequate supporting data. The major issue raised concerned a lack of TSS limitations. Contrary to this stakeholder’s assertion, the effluent guidelines for the Mineral Minding category contain TSS limits for 3 of the 21 subcategories. For 16 of the remaining 18 subcategories, limits are set at no discharge of process wastewater with the exception of stormwater and certain cases (see Part 436). The sand and gravel subcategory and the industrial sand category have limits only for pH. In the event that stakeholders provide additional data and supporting information on these or any of the issues identified above, EPA will reevaluate them at that time.

5.5.8.7 Conclusions

Based on information reported to TRI and PCS, toxic discharges from mineral mining facilities are low relative to other industrial categories. In addition, generally only a few facilities contribute most of the TWPE estimates in both TRI and PCS.

Stakeholders and EPA staff identified various issues associated with discharges from mineral mining facilities. The information in the docket at this time does not support the concerns raised. In the event that stakeholders provide additional data and supporting information during subsequent review cycles, EPA will reevaluate them at that time.

5.5.9 **Oil and Gas Extraction (40 CFR Part 435)**

5.5.9.1 Industry Description

The Oil and Gas Extraction Point Source Category (40 CFR Part 435) comprises facilities in the following SIC codes:

- SIC code 1311 - *Crude Petroleum and Natural Gas*. Establishments primarily engaged in operating oil and gas field properties. Such activities may include exploration for crude petroleum and natural gas; drilling, completing, and equipping wells; operation of separators, emulsion breakers, desilting equipment, and field gathering lines for crude petroleum; and all other activities in the preparation of oil and gas up to the point of shipment from the producing property. This industry includes the production of oil through mining and extraction of oil from oil shale and oil sand and the production of gas and hydrocarbon liquids through gasification, liquefaction, and pyrolysis of coal at the mine site. Also included are establishments that have complete responsibility for operating oil and gas wells for others on a contract or fee basis.
- SIC code 1381 - *Drilling Oil and Gas Wells*. Establishments primarily engaged in drilling wells for oil or gas field operation for others on a contract or fee basis. This industry includes contractors that specialize in spudding in, drilling in, re-drilling, and directional drilling.
- SIC code 1382 - *Oil and Gas Field Exploration*. Establishments primarily engaged in performing geophysical, geological, and other exploration services for oil and gas on a contract or fee basis.
- SIC code 1389 - *Oil and Gas Field Services, Not Elsewhere Classified*. Establishments primarily engaged in performing oil and gas field services, not elsewhere classified, for others on a contract or fee basis. Services included are excavating slush pits and cellars; grading and building of

foundation at well locations; well surveying; running, cutting, and pulling casings, tubes, and rods; cementing wells; shooting wells; perforating well casings; acidizing and chemically treating wells; and cleaning out, bailing, and swabbing wells.

EPA had difficulty in estimating pollutant discharges from this industrial sector. The oil and gas extraction industry does not report discharges to TRI.⁶ Additionally, there is very little information in PCS about discharges from facilities in this industry as most are regulated under general permits. Overall, discharge monitoring data for this sector is not incorporated into PCS. Table 5-174 lists the facilities in the oil and gas extraction industry as reported in PCS and TRI. As shown in Tables 5-175 and 5-176, EPA previously estimated the number of offshore and coastal oil and gas extraction wells and facilities. These estimates are significantly higher than the number of facilities that report to either PCS or TRI. At the current time, EPA is unable to accurately estimate the pollutant loadings associated with this industrial sector using TRI or PCS.

Table 5-174. Number of Facilities in the Oil and Gas Extraction Category

SIC Code	1997 Census	PCS			TRI				
		Total	Major Dischargers	Minor Dischargers	Total Reporting to TRI	No Reported Discharge	Direct Discharge	Indirect Discharge	Both direct and indirect
1311	7,784	178	5	173	1	1	1	0	0
1381	1,628	0	0	0	0	0	0	0	0
1382	1,197	1	0	1	0	0	0	0	0
1389	6,082	11	0	11	0	0	0	0	0
Total	16,691	190	5	185	0	0	0	0	0

Source: PCSLoads2000 and TRIRelases2000.

⁶ EPA identified that oil and gas extraction is believed to conduct significant management activities that involve EPCRA section 313 chemicals. In its proposed rule (June 27, 1996; 61 FR 33592), EPA deferred action on this industry group “because of questions regarding how particular facilities should be identified.” EPA further stated that “EPA will be addressing these issues in the future.”

Table 5-175. Number of Wells Drilled Annually, 1995 - 1997, by Geographic Area

Data Source	Shallow Water (<1,000 ft)		Deep Water (≥ 1,000 ft)		Total Wells	
	Development	Exploration	Development	Exploration		
Gulf of Mexico¹						
MMS:	1995	557	314	32	52	975
	1996	617	348	42	73	1,080
	1997	726	403	69	104	1,302
	Average Annual	640	355	48	76	1,119
RRC		5	3	NA	NA	8
Total Gulf of Mexico		645	358	48	76	1,127
Offshore California¹						
MMS:	1995	4	0	15	0	19
	1996	15	0	16	0	31
	1997	14	0	14	0	28
	Average Annual	11	0	15	0	26
Coastal Cook Inlet¹						
AOGC:	1995	12	0	0	0	12
	1996	5	1	0	0	6
	1997	5	2	0	0	7
	Average Annual	7	1	0	0	8

Source: Technical Development Document for the Final Phase I 316(b) Cooling Water Intake Structure Regulations, EPA-821-R-01-036, Chapter 6, November 2001.

NA -Not applicable.

MMS - Mineral Management Service.

¹Gulf of Mexico figures do not include wells within state bay and inlet waters (considered “coastal” under 40 CFR Part 435) and state offshore waters (0-3 miles from shore). In August 2001, there were 1 and 23 drilling rigs in bay and inlet waters of Texas and Louisiana, respectively. There were also 19 and 112 drilling rigs in state offshore waters (0-3 miles from shore), respectively.

Table 5-176. Identification of Oil and Gas Extraction Fixed Facilities in the Gulf of Mexico Outer Continental Study

Category	Count	Remaining Count
All structures	5,026	5,026
Abandoned structures	1,403	3,623
Structures classified as production structures (i.e., with no well slots and production equipment)	245	3,378
Structures known not to be in production	688	2,690
Structures with missing information on product type (oil or gas or both)	309	2,381

Table 5-176 (Continued)

Category	Count	Remaining Count
Structures whose drilled well slots are used solely for injection, disposal, or as a water source	0	2,381

Source: Technical Development Document for the Final Phase I 316(b) Cooling Water Intake Structure Regulations, EPA-821-R-01-036, Chapter 6, November 2001.

Note: These figures do not include mobile offshore drilling units that are also subject to the oil and gas effluent guidelines. Depending on drilling activity, there are approximately between 100 to 200 of these facilities in the Gulf of Mexico.

Note: Most offshore oil and gas extraction facilities are located in the Gulf of Mexico. Additionally, there are 37 oil and gas extraction facilities offshore of California and 17 oil and gas extraction facilities in Cook Inlet, Alaska.

EPA will attempt to better quantify discharges from these facilities in future annual reviews. In particular, EPA will coordinate its annual reviews of effluent guidelines with the Integrated Compliance Information System (ICIS).⁷ This new system will integrate data that is currently located in more than a dozen separate data systems including the PCS database. ICIS will feature desktop access and real-time entry and retrieval of discharge monitoring data. The current schedule is to expand core enforcement and compliance data to support a broader range of CWA programmatic needs by 2006. For example, EPA will add state and federal CWA permitting and state enforcement data, include data requirements for new programs, and develop permit application and calculation tools.

5.5.9.2 Regulatory Background

EPA promulgated BPT limitations on April 13, 1979 (44 FR 22069) for this point source category. The Agency promulgated BAT and BCT limitations and NSPS for the offshore subcategory (March 4, 1993; 58 FR 12454) and coastal subcategory (December 16, 1996; 61 FR 66086). More recently, EPA established BAT limitations and NSPS for nonaqueous drilling fluids within the offshore and coastal subcategories (January 22, 2001; 66 FR 6850). These recent effluent guidelines revisions did not consider any other wastestreams (e.g., produced waters, drilling cuttings associated with aqueous drilling fluids) in these two subcategories. The applicability of these effluent guidelines includes:

- *Subpart A: Offshore Subcategory.* The provisions of this subpart are applicable to those facilities engaged in field exploration, drilling, well production, and well treatment in the oil and gas industry that are located in waters that are seaward of the inner boundary of the territorial seas ("offshore") as defined in section 502(g) of the Clean Water Act.

⁷ See <http://www.epa.gov/oeca/planning/data/modernization/index.html>.

- *Subpart C: Onshore Subcategory.* The provisions of this subpart are applicable to those facilities engaged in the production, field exploration, drilling, well completion, and well treatment in the oil and gas extraction industry which are located landward of the inner boundary of the territorial seas as defined in 40 CFR Part 125.1(gg) and which are not included within Subparts D, E, or F, provided, however, that the applicability of this subpart to (a) facilities in existence on April 13, 1979 or thereafter engaged in the production, field exploration, drilling, well completion, and well treatment in the oil and gas extraction industry which are located on land and which would have been considered “coastal” as defined under the interim final regulations for this industry (40 CFR Part 435.41, 41 FR 44942, October 13, 1976) or which are (b) located in the Santa Maria Basin of California is suspended.
- *Subpart D: Coastal Subcategory.* The provisions of this subpart are applicable to those facilities engaged in field exploration, drilling, well production, and well treatment in the oil and gas industry in areas defined as "coastal." The term "coastal" shall mean:
 - Any location in or on a water of the United States landward of the inner boundary of the territorial seas, or
 - Any location landward from the inner boundary of the territorial seas and bounded on the inland side by the line defined by the inner boundary of the territorial seas eastward of the point defined by latitude and longitude boundaries listed in the regulation.
- *Subpart E: Agricultural and Wildlife Water Use Subcategory.* The provisions of this subpart are applicable to those onshore facilities located in the continental United States and west of the 98th meridian for which the produced water has a use in agriculture or wildlife propagation when discharged into navigable waters. These facilities are engaged in the production, drilling, well completion, and well treatment in the oil and gas extraction industry.
- *Subpart F: Stripper Subcategory.* The provisions of this subpart are applicable to those onshore facilities which produce 10 barrels per well per calendar day or less of crude oil and which are operating at the maximum feasible rate of production and in accordance with recognized conservation practices. These facilities are engaged in production, and well treatment in the oil and gas extraction industry. There are no effluent guidelines for facilities in this subcategory.

- *Subpart G: General Provisions.* This subpart is intended to prevent oil and gas facilities, for which effluent limitations guidelines and standards, new source performance standards, or pretreatment standards have been promulgated under this part, from circumventing the effluent limitations guidelines and standards applicable to those facilities by moving effluent produced in one subcategory to another subcategory for disposal under less stringent requirements than intended by this part.

EPA also evaluated whether industrial operations not currently regulated by existing effluent guidelines should be addressed as a potential additional subcategory under an existing point source category rather than as a new industrial category. EPA compared the processes, operations, wastewaters, and pollutants addressed by each existing point source category to the processes, operations, wastewaters, and pollutants of the potential additional subcategory. If these processes, operations, wastewaters, and pollutants were sufficiently similar, EPA included those similar industrial operations not currently regulated by existing effluent guidelines in the Agency's review of existing effluent guidelines. Due to the similar processes, operations, and wastewater sources, EPA reviewed coalbed methane (CBM) extraction as part of the Oil and Gas Extraction Point Source Category review. Section 5.5.9.7 provides more information on this review.

5.5.9.3 Wastewater Characteristics and Pollutant Sources

The primary wastestreams in the oil and gas industry are those associated with drilling wastes and produced water. Drilling wastes are cuttings (rock fragments) and muds that are brought to the surface in the drilling fluid. Produced water is the water brought to the surface with the oil.

Produced water is the largest volume waste produced by oil and gas extraction. Nearly 8 barrels of produced water are brought to the surface for every one barrel of oil produced. The pollutants present in produced water vary from region to region and depend of the depth of the production zone and the age of the well, among other factors. Typically, produced water contains:

- High concentrations of chloride, sodium, magnesium, potassium;
- Organic compounds such as benzene, naphthalene, toluene, phenanthrene, and oxygen-demanding compounds;
- Inorganics such as lead, arsenic, barium, antimony, sulfur and zinc; and
- Radionuclides including uranium, radon, and radium.

Table 5-177 lists the processes and associated wastewaters produced in the oil and gas extraction industry.

Table 5-177. Process Wastewater Sources for the Oil and Gas Extraction Industry

Process	Process Wastewater
Well Development	Drilling muds, organic acids, alkalis, diesel oil, crankcase oils, acidic stimulation fluids (hydrochloric and hydrofluoric acid).
Production	Produced water possibly containing heavy metals, radionuclides, dissolved solids, oxygen-demanding organic compounds, and high level of salts. Also, may contain additives including biocides, lubricants, corrosion inhibitors. Wastewater containing glycol, amines, salts, and untreatable emulsions.
Maintenance	Completion fluid, wastewater containing well-cleaning solvents (detergents and degreasers), paint, stimulation agents.
Abandoned Wells, Spills, and Blowouts	Escaping oil and brine.

Source: *Profile of the Oil and Gas Extraction Industry*, EPA Office of Compliance Sector Notebook Project. EPA/310-R-99-006. October 2000.

Produced water has been found to be anoxic and contain high concentrations of oxygen-demanding pollutants. Both soluble and dispersed oil that is contained in produced water have been found to contribute oxygen-demanding pollutants to receiving waters.^{8,9} The oil contained in produced water is also a major source of total organic carbon and chemical oxygen demand in the discharge (1). Metabolic pathways utilized to degrade hydrocarbons by different organisms include oxidative phosphorylation or respiration by heterotrophic bacteria, fungi, and heterotrophic phytoplankton, nitrate reduction by denitrifying bacteria, and sulfate reduction.¹⁰ The oil contained in produced water is also a major source of Total Organic Carbon and Chemical Oxygen Demand (COD) in the discharge (1). Produced water has been found to have concentrations of COD and BOD in the ranges of 400 to 3,000 mg/L and 370 to 1,920 mg/L, respectively (1).

5.5.9.4 Pollutants of Concern Identified

As previously mentioned, PCS and TRI contain limited information for this industrial sector. Table 5-178 presents the available pollutant information from the PCS and TRI databases for the pollutants composing the top 95 percent of the TWPE for this industry.

⁸ Stephenson, M., *A Survey of Produced Water Studies*, Produced Water, Edited by J. Ray and F. Engelhart, Plenum Press, New York, 1992.

⁹ Development Document for Interim Final Effluent Limitations Guidelines and Proposed New Source Performance Standards for the Oil and Gas Extraction Point Source Category, EPA 440/1-76/055-a, United States Environmental Protection Agency, September, 1976.

¹⁰ National Research Council, *Oil in the Sea III, Inputs, Fates, and Effects*, The National Academies, 2002.

Table 5-178. Pollutant Discharges Reported to PCS and TRI for 2000

SIC Code	Pollutant	Number of Facilities Reporting Pollutant	Total Load (lbs/yr)	Total TWPE/yr	Percentage of Total SIC Code TWPE	Cumulative Percentage of Total SIC Code TWPE
PCS Data						
1311	Chlorine, total residual	4	527	256	96%	96%
PCS Total		5	597,255	267		
TRI Data						
1311	Benzene	1	255	4.7	62%	62%
1311	Toluene	1	255	1.4	19%	81%
1311	Xylene (mixed isomers)	1	255	1.1	14%	95%
TRI Total		1	1,020	7.6		

Source: EPA, *TRIReleases2000* and *PCSLoads2000*.

EPA also reviewed the Technical Development Documents for the offshore and coastal effluent guidelines and the following two documents to identify pollutants of concern for this category: (1) *A White Paper Describing Produced Water from Production of Crude Oil, Natural Gas, and Coal Bed Methane*, U.S. DOE, Veil et al., 2004; and (2) *Bioaccumulation in Marine Organisms: Effect of Contaminants from Oil Well Produced Water*, Battelle, J.M. Neff, 2002. EPA will continue to evaluate these and other data sources in the next annual effluent guidelines review to identify pollutants of concern.

5.5.9.5 Offshore Subcategory (Subpart A)

This subsection discusses available data and technology options for the offshore subcategory of the oil and gas extraction industry.

Data Summary

Because of the limited PCS data obtained during the screening-level review, EPA requested offshore oil and gas PCS data from the four EPA Regional offices that issue permits for the Outer Continental Shelf (e.g., EPA Regions 4, 6, 9, and 10). As a result of this data collection effort (see DCN 00929, 00930, 00931, 00932, or 00952; section 3.01), only one facility, Union Oil Company of California (NPDES permit GMG290128), provided data, which are presented in Table 5-179.

Table 5-179. 2000 Discharge Monitoring Report (DMR) Data for the Union Oil Company of California.

Parameter	Unit	Reported Measurement Values	
		Average	Range
Produced Water, Radium 226, Total	pci/l	360	0 - 1,540
Produced Water, Radium 228, Total	pci/l	261	0 - 1,145
Produced Water Toxicity 7 Day NOEC	ppm	5,391	0 - 43,200
Drilling Fluid Toxicity	ppm	591,573	0 - 1,000,000
Well Fluids, Oil and Grease	mg/L	16	0 - 457
Cadmium (Cd), in Barite, Dry Weight	mg/kg	0.7	0 - 2
Mercury (Hg) in Barite, Dry Weight	mg/kg	0.5	0 - 1
Drilling Fluids, Free Oil	days	0.03	0 - 1
Drilling Fluids, Discharge Rate	barrel/hr	346	0 - 875
Drill Cutting, Free Oil	days	0	0
Deck Drainage, Free Oil	days	0.02	0 - 1
Produced Water, Oil and Grease	mg/L	27	0 - 109
Produced Water, Flow	MGD	0.1	0 - 0.8
Well Fluids, Free Oil	days	0	0
Sanitary Waste, Solids	days	0	0
Domestic Waste, Solids	days	0	0
Misc. Free Oil in Western GOM	days	0	0

Technology Options

In the 1993 rulemaking for this subcategory, EPA set the BAT limitations and NSPS for produced water [oil and grease limits for produced water at 29 mg/L (maximum average of daily values for one month) and 42 mg/L (daily max)] based on improved operating performance of gas flotation technology. At the time it promulgated these ELGs, EPA rejected setting BAT limitations and NSPS for produced water based filtration systems as these technologies were still under development and not in widespread use.

However, new technologies, including filtration systems, are now available for produced water treatment, in which produced waters are treated by a secondary treatment process before final discharge overboard. More stringent regulation of oil and gas extractions wastes (including produced water) in other countries has led to the development of many

advances in cuttings and produced water treatment technologies and management options. For example, the Norwegian sector of the North Sea is moving towards "zero discharge" of harmful materials.

This subsection summarizes preliminary information on potential technology treatment options for produced water. Three produced water treatment technologies are currently used by industry in the U.S.: (1) Macro Porous Polymer Extraction System (MPPE); (2) Symons Adsorption Media (SAM); and (3) Cetco's Polishing System. Other produced water treatment technologies are used in other countries and include: (1) CTour Process; (2) Epcon CFU; (3) Mare's Tail®; and (4) Total Oil Remediation and Recovery (TORR®). Two produced water treatment technologies (CTour and Epcon CFU) are scheduled for installation on oil and gas extraction facilities after full-scale field trials.

Macro Porous Polymer Extraction System (MPPE)

In this system, the hydrocarbon contaminated water is passed through a column packed with MPPE particles.^{11,12} An extraction liquid within the column removes the hydrocarbons from the water in a single pass. The purified water then passes out to be reused or discharged.

The extraction liquid is regenerated periodically using low-pressure steam. The process removes the hydrocarbons the MPPE particles by steam stripping and retains the extraction liquid in the pores of the polymer. After condensing, the waste stream divides into an organic and an aqueous phase in a gravity separator. The aqueous condensate is returned to the extraction column and the organic phase is separated for reuse or removal. The use of two interchangeable columns allows a continuous process (one performing extraction and one undergoing regeneration). There is no flow rate restriction in this technology. The MPPE system removes 99.9 percent of hydrocarbons from water.

Symons Adsorption Media (SAM)

Symons developed a state-of-the-art media adsorption system to remove dispersed and emulsified hydrocarbons as well as heavy metals from produced water.¹³

¹¹ Azko Nobel. Macro Porous Polymer Extraction System. 2004. See: <http://www.environmental-center.com/technology/akzonobel/mppe.htm#process>.

¹² Meijer, D.T. and C.A.T. Kuijvenhoven. May 2001. Field-Proven Removal of Dissolved Hydrocarbons from Offshore Produced Water by the Macro Porous Polymer Extraction Technology. Presented at the 2001 Offshore Technology Conference in Houston, TX. See: <http://www.environmental-center.com/articles/article1058/article1058.htm>.

¹³ Symon Ltd. Produced Water Treatment Polishing System. 2003. See: <http://www.symons.co.uk/PWT.pdf>.

Symons adsorption media is granular, organic material with a surfactant. This media material can adsorb about 50 to 200 percent of its own weight of oil and 99 percent of all emulsified and dissolved oils in one pass. The media is contained in canisters that have extended axial flow paths, which offer a deeper adsorption bed. The spent media can be used as fuel. Benefits of SAM over activated carbon are: (1) up to 10 times the adsorption capacity; and (2) one-third to one-half the cost of activated carbon. SAM can be used to remove aromatics, free oil, emulsified oil, PCBs, PAHs and phenols.

Cetco's Polishing System

Cetco developed a media adsorption system to remove dispersed and emulsified hydrocarbons and dissolved heavy metals from produced water.¹⁴ This technology includes a resin, polymer, and clay media packed in canisters. The Cetco polishing system consists of the following components:

- **Solids filtration and chemical treatment:** Prior to contact with the canisterized adsorption media, the produced water is passed through conventional filtration to remove solids such as scale, sand, silt, clay, and chemical flocculants. The water is also chemically treated to prevent scale or build-up within the mechanical filtration equipment.
- **Canisters:** The standard filter for polishing produced water is an 11' X 11' canister, which is filled with about 25 pounds of adsorbent media. The canister is designed for radial flow through an exterior filter cloth, the media bed, and an inner filter cloth. A large accumulation area at the top of each vessel collects coalesced oil droplets that accumulate on the exterior filter cloth. Entrained gases, which also accumulate in the top region, are removed during the purge phase.
- **Adsorption Media:** The patented Crudesorb® adsorption media is of the organoclay family and can adsorb oil molecules when oily salt water flows through the media. As the oil molecules start coating the surface of the media granules, surrounding water molecules are displaced. Various forces hold the oil molecules to the surface of the media, thus making it an irreversible process. The spent media passes the EPA Toxicity Characteristics Leaching Procedure and can be classified as oilfield or nonhazardous waste.

¹⁴ Darlington, J.W. and J.J. Smith. Produced Water Polishing: Filtration and Filter Monitoring System Promotes Compliance During Conventional Treatment Upsets. Presented at EPA's Best Available Technology Conference in February 2003. See: <http://www.muddog.net/papers/CETCO%20PAPER%20FOR%20EPA%20BEST%20AVAIL.%20TECH.%20CONFERENCE%20Feb.%202003.pdf>.

- **Smart Canister™ Technology:** The “smart canister™” continually monitors media adsorption capacity and alerts the platform operators when the media is nearly spent. The smart canister™ contains an embedded probe that electrically measures the media adsorption and relays the information to a nearby alarm panel.

Cetco’s polishing system can reduce water soluble organics by more than 50 percent.

CTour Process

The CTour technology is a liquid-liquid extraction process.¹⁵ In this process, a liquid condensate is used to extract liquid for the dissolved components in produced water. The condensate also helps remove dispersed oil by coalescing with small oil droplets.

The CTour process includes the following steps:

- Harvest a suitable condensate stream from production;
- Inject condensate in liquid form into the produced water stream;
- Mix and disperse the condensate into the water;
- Allow for adequate contact time between condensate and water;
- Separate the contaminated condensate from the water in a separation process; and
- Cycle the condensate, containing contaminants, back to the production stream.

Field trials have been performed on the Ctour process. The process can remove approximately 70 percent of dispersed oil and PAHs, as well as up to 70 percent of most phenols.

Epcon CFU

The Epcon Compact Flootation Unit (CFU) technology can remove hydrocarbons, hydrophobic substances, and particles.¹⁰ The Epcon CFU acts as a 3-phase water/oil/gas separator and is based on the principal of oil coalescence. Centrifugal forces and gas floatation techniques aid in the oil-water separation process. The Epcon CFU is a vertical vessel that has a

¹⁵ Knudsen, B.L. et al. *Meeting the Zero Discharge Challenge for Produced Water*. Presented at Society of Petroleum Engineers Conference in March 2004 in Calgary, Canada.

pipe suspended from the top of the vessel to extract gas, oil, and some water. Treated water exists the vessel at the bottom of the vessel.

Field trials have shown that the Epcon CFU system can produce a 50 to 75 percent reduction in dispersed oil, 32 to 44 percent reduction of PAHS, and a 17 percent reduction in naphthalene.

Mare's Tail®

Opus Plus Ltd. has patented a technology called Mare's Tail®, which is basically an inline coalescer consisting of polypropylene media upstream of a hydrocyclone.¹⁰ The Mare's Tail® process coalesces small dispersed oil droplets in the produced water, thus providing better working conditions for the hydrocyclone process, which is a commonly used process for removing dispersed oil in offshore produced water.

A field trial of the Mare's Tail® demonstrated that the reduction of oil in water from a hydrocyclone can be increased by 25 percent with Mare's Tail®. The Mare's Tail® technology also enhances the removal efficiency of naphthalene, PAHs, and alkylated phenols.

Total Oil Remediation and Recovery (TORR®)

In the TORR® process, the oil-water emulsion to be treated flows through beds of reusable petroleum adsorbent (RPA) separated by gravity settling compartments.¹⁶ The number of beds may vary from 6 to 12 per system. The oil droplets adhere to the free surface of the RPA and also coalesce with each other. As more oil droplets are retained, they are stripped from the RPA. The droplets are entrapped in the interbed compartments where they settle on the top. This is a continuous process that does not end even when the media is completely saturated with oils; therefore, it does not generate oil-saturated wastes or other by-products.

The TORR process can remove oil from water to achieve effluent concentrations of 10 mg/L oil content.

5.5.9.6 Coastal Subcategory (Subpart D)

This subsection discusses available data and technology options for the Coastal subcategory of the oil and gas extraction industry. EPA received comments on the Preliminary Effluent Guidelines Plan from two Cook Inlet native villages and Cook Inlet Keeper stating that EPA should eliminate the existing exemption from zero discharge for facilities in Cook Inlet, Alaska. In addition, these commenters requested that EPA extend this subcategory to include the Lower Cook Inlet, which is in the Offshore subcategory (Subpart A). EPA reviewed data

¹⁶ Le Foll, P. et al. *Field Trials for a Novel Water Deoiling Process for the Upstream Oil and Gas Industry*. Presented at the Society of Petroleum Engineers Conference in March 2004 in Calgary, Canada.

submitted by these commenters for the 2004 annual review of these effluent guidelines and consulted with representatives from the two Cook Inlet native villages.

Data Summary

All facilities regulated by the Coastal subcategory effluent guidelines, except for facilities in Cook Inlet, AK, are prohibited from discharging drill cuttings, produced waters, and all other drilling wastes. Based on the record for the 1996 Coastal effluent guidelines, EPA determined that onsite injection and other zero discharge options were not feasible throughout Cook Inlet, Alaska.¹⁷ Consequently, EPA determined in 1996 that zero discharge for drill cuttings and produced waters was not BAT and set the effluent guidelines for operators in Coastal Cook Inlet as equivalent to the effluent guidelines for operators in the Offshore Subcategory (Subpart A of 40 CFR Part 435). The rationale is described in a *Federal Register* Notice (see 61 FR 66125, Dec. 16, 1996). Therefore, only oil and gas extraction facilities in Cook Inlet are currently allowed to discharge drill cuttings and produced water.

EPA used DMR data for 2001 and 2002 to estimate pollutant discharges for Cook Inlet facilities. As shown in Table 5-180, EPA used these data to estimate pollutant loads in pounds and TWPE (see Section 4.2.3 and 4.2.4 for a description of how EPA estimated TWPE).

Table 5-180. Estimated TWPE from Oil and Gas Extraction Facilities in Cook Inlet, AK

Operator	Facility	2001 TWPE ¹			2002 TWPE ¹		
		Produced Water	Drilling Waste	Total	Produced Water	Drilling Waste	Total
Unocal	Anna Platform	243		243	173		173
	Baker Platform	10		10	8		8
	Bruce Platform	4		4	3		3
	Dillon Platform	521		521	487		487
	Dolly Varden Platform	0		0	0		0
	Granite Pt. Platform	0		0	0		0
	Granite Pt. Prod. Fac.	2		2	6		6
	Grayling Platform	0		0	0		0
	King Salmon Platform	0		0	0		0
	Monopod Platform	0	554	554	0	398	398
	Steelhead Platform	0	2,217	2,217	0		0
	Trading Bay Trmt. Fac	9,198		9,198	9,521		9,521

¹⁷ Coastal Technical Development Document, EPA-821-R-96-023, Section 5.10.3.

Table 5-180 (Continued)

Operator	Facility	2001 TWPE ¹			2002 TWPE ¹		
		Produced Water	Drilling Waste	Total	Produced Water	Drilling Waste	Total
XTO Energy	East Foreland Treatment Facility	195		195	195		195
	Platform A		290	290		0	0
	Platform C		0	0		1,755	1,755
Phillips Oil	Tyonek A Platform	No data			0		0
Forest Oil	Osprey PF- NRs				0	217	217
Total		10,172	3,061	13,233	10,394	2,370	12,763

¹A zero indicates that the facility reported zero discharge to PCS. A blank field indicates that the facility did not report any toxic pollutants.

Drilling Fluids and Drill Cuttings

This section summarizes the technical and economic considerations for 40 CFR Part 435, Subpart D, for BAT and NSPS for drilling fluids and drill cuttings in Cook Inlet, AK.

Rationale EPA Used in the Coastal Effluent Guidelines to Reject Zero Discharge for BAT/NSPS

EPA examined several technologies to achieve zero discharge of drilling fluids and drill cuttings in Cook Inlet: (1) grinding and injection; (2) annular disposal; and (3) onshore disposal. EPA estimated that 89,000 barrels of drilling wastes would be generated annually from coastal Cook Inlet facilities.¹⁸

The first technology involves grinding the drilling fluid, drill cuttings, and dewatering effluent into a slurry that can be injected into a dedicated disposal well. To use this option, however, operators must have different formation zones available with appropriate porosity and permeability to accept the injected wastes. These formation zones cannot be the producing formations because the injected wastes may interfere with hydrocarbon recovery. The North Slope, Alaska, and the coastal region along the Gulf of Mexico have subsurface geology containing relatively porous substrata and formations for injection that are readily available. In contrast, the geology in Cook Inlet is highly fragmented. EPA received comments on the proposed rule that provided several examples where attempts to grind and inject drilling wastes and annular disposal failed in the Cook Inlet area and information in the record indicates that formations for injection may not be available throughout Cook Inlet (61 FR 66096).

¹⁸ See December 16, 1996. 61 FR 66093.

At promulgation of the Coastal effluent guidelines, two operators in Cook Inlet had access to on-land disposal sites for drilling wastes. Other operators had no access to on-land disposal sites in Alaska, and EPA estimated the costs for transport and disposal of drilling wastes at an on-land oil and gas waste disposal site in Oregon. These costs considered the limited storage space available on platforms and harsh safety- and weather-related conditions for transport.

EPA did not select injection because formations may not be available throughout Cook Inlet. EPA considered the onshore disposal as not economically achievable.

Current Review of Zero Discharge

As detailed in Table 5.4.9-2, the declining fields in coastal Cook Inlet means that fewer wells are being drilled and reconditioned than in 1996. This also means that few drill cuttings are being generated now than projected in the Coastal effluent guidelines. Based on the Discharge Monitoring Report data submitted to EPA for 2001 and 2002, less than 14,000 barrels of drilling wastes are generated annually.

As previously discussed, EPA did not identify injection of drill cuttings as the basis for BAT limitations or NSPS because of the uncertainties regarding the availability of geologic formations suitable for injection. While the Cook Inlet geology has not changed, newer geological prospecting techniques may make it possible to better identify suitable formations. Newer technology may also make injection of drill cuttings more available.

Specifically, Unocal (Bruce Platform, 2002) and Marathon (Kenai Gas Field, 1999) recently opened grind and inject facilities. Additionally, recent technological developments to prevent injection well plugging might mean that it is more feasible to inject drilling wastes. EPA also reviewed a U.S. Department of Energy report on slurry injection projects, *Evaluation of Slurry Injection Technology for Management of Drilling Wastes*, May 2003. This report describes several ways in which drilling wastes have been injected into underground formations for permanent disposal and focuses on injection at pressures exceeding the fracture pressure (referred to as slurry injection). The report details how these slurry injection projects are conducted and monitored, the geological conditions that favor slurry injection, and typical costs. The report includes a database describing more than 330 actual slurry injection jobs including four in coastal Cook Inlet. This report states that it is the most comprehensive publicly available source of information on the drilling waste slurry injection jobs. Oilfield wastes injected at these four slurry injection projects include: (1) water-based cuttings (very large particle size); (2) oil-based cuttings; and (3) deck drainage. Volume of material injected ranges from 20,000 to 221,400 barrels of slurry waste at injection rates of 1 to 4 barrels per minute.

In the 2001 synthetic-based drilling fluids (SBF) effluent guidelines, EPA identified that, under most circumstances, operators in coastal Cook Inlet are able to achieve zero discharge with their wastes associated with nonaqueous drilling fluids, drill cuttings, and dewatering effluent. Consequently, under most normal circumstances, operators in coastal Cook

Inlet are required to meet the same standards (zero discharge) for nonaqueous drilling fluids, drill cuttings, dewatering effluent as other operators regulated by the Coastal subcategory.¹⁹ EPA established a three-test procedure in the SBF effluent guidelines for allowing the discharge of SBF drill cuttings in coastal Cook Inlet. Operators in Cook Inlet are prohibited from discharging SBF drill cuttings except when they are unable to dispose of their SBF cuttings through: (1) on-site injection (annular disposal or Class II UIC); (2) injection using a nearby coastal or offshore Class II UIC disposal well; or (3) onshore disposal using a nearby Class II UIC disposal well or land application. Coastal Cook Inlet operators are required to demonstrate to the NPDES permit authority that none of the above three disposal options are technically feasible in order to qualify for the alternate BAT limitation (see January 22, 2001; 66 FR 6867). Operators that qualify for the alternate BAT limitation are allowed to discharge SBF drill cuttings at the same BAT limitations as operators in the Offshore subcategory.

With respect to economic factors associated with a zero discharge requirement for drill cuttings, existing oil and gas extraction projects are unlikely to be in better financial condition in 2004 than they were in 1996 when the coastal effluent guidelines were promulgated. Although oil and gas prices have undergone a recent spike, the fields have experienced eight years of declining production associated with depleting a natural resource. Comparing the production figures from 1995 (the baseline for the Coastal Cook Inlet analysis) and historic and projected data from the state of Alaska (with 2002 as the last full year of historic data) shows the following:

- Trading Bay Field production has declined about 92 percent;
- Granite Point Field production has declined at least 70 percent;
- Middle Ground Field production has declined about 17 percent; and
- Tyonek production (counted with Kenai Field onshore production) has declined at least 75 percent from 1995.

In the Coastal effluent guidelines, EPA estimated that one platform would shut-in (close) under a zero discharge option. However, EPA's review of current economic information indicates that all Cook Inlet facilities should now be considered marginal due to declining production. Since promulgation of the Coastal effluent guidelines, no new coastal oil and gas disposal sites have opened in the Cook Inlet. Therefore, the costing assumptions for transporting the wastes to a disposal site in the contiguous U.S. not changed since 1996; however, the volume of drilling waste is lower than projected in 1996.

¹⁹ Development Document for Final Effluent Limitations Guidelines and Standards for Synthetic-Based Drilling Fluids and Other Non-Aqueous Drilling Fluids in the Oil and Gas Extraction Point Source Category, EPA-821-B-00-013, Chapter VII.5.4 (Page VII-62) and Chapter X.3.3.1 (Page X-3), <http://www.epa.gov/waterscience/guide/sbf/final/eng.html>, December 2000.

With respect to existing coastal Cook Inlet oil and gas extraction facilities, EPA does not know how widely new injection techniques and technologies can be used across all Cook Inlet facilities. Moreover, given that all existing coastal Cook Inlet oil and gas extraction facilities are considered marginal, it is unclear whether the incremental compliance costs associated with a zero discharge requirement would cause these facilities to shut in. EPA will examine the economic and technological progress of these injection technologies in future annual reviews of this industrial sector.

Additionally, since promulgation of the Coastal effluent guidelines, there is only one new oil and gas facility in Cook Inlet. The Osprey Platform is the first new platform established in Cook Inlet in about 16 years and currently disposes of its drilling wastes through annular disposal or Class II injection in approved wells. Thus, EPA has determined zero discharge of drilling wastes to be economically and technically achievable for *this* project. Part of that decision might rest on the availability of a suitable formation for disposal at that site. As previously discussed, EPA does not know how widely these new zero discharge techniques and technologies for drill cuttings can be used across all Cook Inlet facilities.

Given the 16-year lag between NSPS projects, the ability of the permit writer to require an operator to demonstrate that zero discharge is not technically feasible for a specific project, and the relatively low toxicity of the discharges, EPA decided not to revise effluent guidelines for drill cuttings discharges in this subcategory at this time.

Produced Water

This subsection summarizes the technical and economic considerations for 40 CFR Part 435, Subpart D for BAT and NSPS for produced water in Cook Inlet, AK.

Rationale EPA Used in the Coastal Effluent Guidelines to Reject Zero Discharge for BAT/NSPS

EPA examined injection technology to achieve zero discharge of produced water in Cook Inlet in the 1996 Coastal effluent guidelines. As previously mentioned, Cook Inlet is different from other coastal regions in that the production formation is usually the only formation available for the injection of produced water. For existing projects in Cook Inlet, EPA estimated the costs of piping produced water from existing production facilities to existing waterflood injection sites. EPA's economic analysis in the Coastal effluent guidelines estimated that 1 of 13 platforms would close and 2 additional platforms would incur severe economic impacts. Consequently, EPA rejected zero discharge in the Coastal effluent guidelines as not economically feasible for Cook Inlet.

EPA rejected zero discharge of produced water for NSPS for Cook Inlet because of uncertainties regarding the availability of geologic formations suitable for receiving injected produced water. Because the location and availability of formations for a new source in Cook

Inlet are unknown, EPA could not estimate the maximum cost associated with piping produced water from the wellhead to the nearest injection well.

Current Review of Zero Discharge

As mentioned previously, Osprey is the first new platform set in Cook Inlet in about 16 years. It is the first platform in Cook Inlet *designed* to reinject all produced water from the platform.²⁰ Thus, EPA has determined zero discharge of drilling wastes to be economically and technically achievable for *this* project. Part of that decision might rest on the availability of a suitable formation for disposal at that site. In addition, the Osprey platform qualified for a special royalty reduction incentive offered by the state of Alaska. The reduced royalty is 5 percent (in contrast to the more typical 12.5 percent) and production must have started by January 1, 2004.²¹ If zero discharge of produced water is technically feasible for a new project, whether it is economically feasible will depend on the royalty rates, potential incentives offered by the state, and oil and gas prices at that time.

Newer injection technology might also make injection of produced water more available. However, EPA does not know how widely these newer technologies can be used across all Cook Inlet facilities. EPA will examine the progress of these technologies in future annual reviews. Given the 16-year lag between NSPS projects, the ability of the permit writer to require an operator to demonstrate that zero discharge is not technically feasible for a specific project, and the relatively low toxicity of the discharges, EPA decided not to revise effluent guidelines for produced water in this subcategory at this time.

Summary

At this time, EPA concluded it should not identify these effluent guidelines for revision in the current effluent guidelines plan. EPA will examine the progress of newer zero discharge technologies for drill cuttings and produced waters in future annual reviews.

Additionally, in response to public comments that it should revise the applicability section of the Coastal subcategory, EPA has decided not to reclassify lower Cook Inlet as part of the Coastal subcategory because that would change a long-standing definition relying on “the inner boundary of the territorial seas” as a line between coastal and offshore. See EPA’s Response to Public Comments on Effluent Limitations Guidelines and Standards for the Coastal Subcategory of the Oil and Gas Extraction category, October 30, 1996 (“EPA Response to Comments”), R. IIIB.(c) 1, Topic Code H, pp. H-1 – H-17. Rather than revise the applicability criteria for these effluent guidelines, EPA will evaluate available and affordable technologies for

²⁰ K. Nelson, “Money, time, an assist from the Legislature were all required to bring Redoubt Shoal online,” *Petroleum News*, Vol. 7, No. 52. December 2002. www.ptroleumnews.com/pnarchpop/021229-12.html.

²¹ See http://www.dog.dnr.state.ak.us/oil/products/publications/otherreports/2002_annual_report/2002_annual_report.pdf.

facilities in upper Cook Inlet (regulated by the Coastal effluent guidelines) and in lower Cook Inlet (regulated by the Offshore effluent guidelines). Currently, there are no oil and gas extraction facilities in lower Cook Inlet.

5.5.9.7 Coal Bed Methane Extraction

This section discusses a potential additional subcategory of the oil and gas extraction industry, coalbed methane (CBM) extraction. EPA determined that CBM extraction is appropriately considered an additional subcategory of the Oil and Gas Extraction category (Part 435). EPA based this determination on the similarity of processes, operations, wastewater, and treatment technology options of CBM extraction to those of oil and gas extraction regulated by the existing ELG. EPA did not consider CBM production in developing the 1979 national technology-based effluent limitations guidelines for the Onshore and Agricultural and Wildlife Water Use subcategories of the Oil and Gas Extraction category (40 CFR Part 435, Subparts C and E) because there was no significant CBM production in 1979.²²

Additionally, EPA did not consider CBM production in developing the coal mining effluent guidelines. EPA established effluent guidelines for coal mining operations based on the use of BPT for existing sources in the Coal Mining Point Source Category (40 CFR Part 434) on April 26, 1977 (42 FR 21380). These effluent guidelines were revised on October 9, 1985 (50 FR 41296). More recently, EPA revised these ELGs again on January 23, 2002 (67 FR 3370) by adding two new subcategories to address preexisting discharges at coal remining operations and drainage from coal mining reclamation and other nonprocess areas in the arid and semi-arid western United States. None of these rulemakings considered coalbed methane extraction in any of the supporting analyses or records.

Therefore, permit writers develop technology-based limits for the CBM NPDES discharge permits using a best professional judgment (BPJ) basis (see 40 CFR Part 125.3(c)(2)). NPDES permit writers can develop BPJ limits by using one of two different methods. A permit writer can either transfer numerical limitations from an existing source such as from a similar NPDES permit or an existing set of effluent guidelines, or derive new numerical limitations.

Impacts to surface water from discharge of CBM water can be severe depending upon the quality of the CBM water. Neil et al. (1980) report that saline discharges have variable effects depending on the biology of the receiving stream and the instream concentration of produced water. Some water bodies and watersheds may be able to absorb the discharged water while others are sensitive to large amounts of low-quality CBM water. Aquatic and benthic communities can be adversely impacted (e.g., decrease in species diversity, density) by the constituents in CBM water (e.g., TDS, chloride, metals, organics). Discharge of this water may also cause erosion and in some cases irreversible soil damage from high TDS concentrations. This may limit future agricultural and livestock uses of the water and watershed.

²² Letter from Thomas P. O'Farrell, EPA's Industrial Technology Division, to Constance B. Harriman, Steptoe & Johnson. June 1, 1989.

In outreach and in public comments, environmental advocacy groups and surface rights groups (e.g., farmers, ranchers) requested that EPA establish effluent guidelines for this industry.

Industry Description

As plant material is progressively converted to coal, large quantities of methane-rich gas are generated that are stored within the coal. Coalbed methane is held in place in the coal seam by the water pressure of natural underground aquifers. Drilling and pumping these aquifers is necessary to reduce the water pressure exerted by the aquifers and produce coalbed methane. By pumping the aquifers, the methane is separated from the water in the borehole and flows to the pipeline. The natural gas consists of approximately 96 percent methane, 3.5 percent nitrogen, and trace amounts of carbon dioxide (CO₂).

Exploration costs for CBM are low, and the wells are cost-effective to drill. Methane occurs in most coals, and the location of the Nation's coal resources is already well known. Table 5.4.9-8 identifies the most significant sources of current CBM production.

Large amounts of water, sometimes saline, are produced from CBM wells. Coalbed gas wells have a distinctive production history characterized by an early stage, in which large amounts of water are produced to reduce reservoir pressure, which in turn encourages release of gas; a stable stage, in which quantities of produced gas increase as the quantities of produced water decrease; and a late stage, in which the amount of gas produced declines and water production remains low. In addition, EPA notes that recent court actions confirm that CBM water is a pollutant subject to regulation under the CWA.²³

Table 5-181. Current Sources of CBM Production

Basin Name	Year of Initial Production	States	Total Number of CBM Wells (1999)	Cumulative Production 1981 - 1999 (billion cubic feet)
Black Warrior	1980	AL	2,989	1,079.02
San Juan	1979	NM, CO	3,311	6,648.44
Powder River	1993	WY, MT	1,657	119.78
Wind River	recent	WY	0	0
Greater Green River	1999	WY, CO	2	1.93

²³ In August 2002, the Federal District Court in Montana granted summary judgment that CBM-produced water is not a pollutant within the meaning of the CWA (*Fidelity Exploration Co. v. Northern Plains Resource Council*). In April 2003, the 9th Circuit Court of Appeals reversed this decision and reaffirmed that, "unaltered groundwater produced in association with methane gas extraction, and discharged into the river, is a pollutant within the meaning of the CWA." In October 2003, the U.S. Supreme Court declined to review the decision by the Court of Appeals. This action lets stand the decision of the 9th Circuit Court of Appeals (i.e., "The plain language of the CWA requires the conclusion that CBM water is a pollutant subject to regulation under the CWA.").

Table 5-181 (Continued)

Basin Name	Year of Initial Production	States	Total Number of CBM Wells (1999)	Cumulative Production 1981 - 1999 (billion cubic feet)
Raton	1995	CO, NM	405	67.77
Uinta-Piceance	~1995	CO, UT	410	156.05
Central Appalachian Coal Basin	N/A	KY, TN, VA, WV	N/A	5,000 ¹
Northern Appalachian Coal Basin	N/A	PA, WV, OH, KY, MD	N/A	61,000 ¹
Western Interior Coal Region	N/A	AK, OK, KS, MO, NE, IA	N/A	>15,000 ¹
Western Washington Coal Regions	N/A	WA, OR	N/A	300 - 24,000 ¹

Sources:

North American Coalbed Methane Resource Map (Gas Technology Institute. 2001).

Draft Evaluation of Impacts to Underground Sources of Drinking Water by Hydraulic Fracturing of Coalbed Methane Reservoirs, Horsley & Witten, Inc., September 19, 2001.

N/A - Not available.

¹Figure represents estimated amount of CBM and not cumulative production.

Note: EPA also summarized available information on coalbed methane operations in Alaska.

Pollutants of Concern

The principal environmental problem associated with production of CBM is disposal of large quantities of produced water (i.e., billions of gallons per year). The major pollutant of concern is total dissolved solids (TDS) and the sodium adsorption ratio (SAR). CBM- produced water TDS concentrations range from below 500 to 30,000 mg/L. Table 5-182 presents the estimated raw pollutant loadings and discharged pollutant loadings from CBM operations.

Table 5-182. Estimated CBM Industry Pollutant Loadings

Pollutant	Raw Waste Loadings		Discharge Loadings	
	(Thousand lb/yr)	(Thousand TWPE/yr)	(Thousand lb/yr)	(Thousand TWPE/yr)
Total Nonconventional	347,830 - 10,294,325	327 - 12,240	95,660 - 4,746,985	1.2 - 142
TDS	222,833 - 5,245,180	NA	68,667 - 2,348,250	NA
Iron	57,917 - 2,169,780	324 - 12,150	10 - 15,152	0.06 - 85
Chloride	38,101 - 1,427,405	0.9 - 35	2,043 - 1,166,996	0.05 - 28
Sodium	26,170 - 1,007,104	0.1 - 6	22,433 - 852,012	0.1 - 5
Calcium	1,696 - 68,119	0.05 - 2	1,532 - 59,037	0.04 - 2

Table 5-182 (Continued)

Pollutant	Raw Waste Loadings		Discharge Loadings	
	(Thousand lb/yr)	(Thousand TWPE/yr)	(Thousand lb/yr)	(Thousand TWPE/yr)
Potassium	671 - 23,719	0.7 - 25	603 - 6,143	0.6 - 6
Magnesium	346 - 18,446	0.3 - 16	310 - 15,378	0.3 - 13
Sulfate	59 - 332,511	0.0003 - 2	45 - 283,486	0.0003 - 2
Barium	35 - 2,061	0.07 - 4	17 - 535	0.03 - 1
Priority and conventional pollutants are not present in CBM water in significant quantities.				

Source: U.S. EPA, 2003. Analysis of Discharge Data for Six Industry Categories, DCN 00632, Section 3.0.
NA - Not applicable.

Wastewater Treatment and Disposal

Water management options may include several zero discharge options (e.g., injection, discharge to evaporation ponds, irrigation) and treatment and discharge to surface waters. Injection wells, which require suitable formations for disposal, are the preferred method of disposal in the San Juan Basin and central Appalachian basin²⁴, whereas discharge into surface streams, after treatment in ponds to meet water-quality regulations, occurs in the Black Warrior basin, Alabama.²⁵

This section summarizes preliminary information on potential technology treatment and disposal options for produced water. Treatment and disposal methods used to treat, dispose, or otherwise manage CBM-produced water include: surface-water discharge with beneficial reuse, storage/evaporation ponds, injection into a subsurface aquifer, iron oxidation, reverse osmosis, ion exchange, electrodialysis, precipitation, downhole gas/water separation, freeze/thaw evaporation, and the Harmon SO₂ Generator.

EPA developed capital and operating costs associated with these water disposal or treatment methods and used them in an economic impact model of CBM production in the Powder River Basin²⁶. The economic analysis uses a financial model based on a discounted cash-flow approach that has been used for the economic analyses of several oil and gas industry-related effluent guidelines. The general approach takes a number of model projects that are

²⁴ Rice, 1995.

²⁵ Rogers, 1994.

²⁶ EPA prepared a draft report "Guidance for Developing Technology-Based Limits for Coalbed Methane Operations: Economic Analysis of the Powder River Basin" to provide guidance for EPA Region 8 to use for its "best professional judgment" to prepare CWA NPDES permits on Indian lands that are under Region 8 jurisdiction.

specified on the basis of gas and water production volumes, using data and assumptions about costs of gas production, royalty and severance tax rates, price of gas, costs of project construction, number of wells per project, and other information. Costs of CBM-produced water management are used in the model to prepare a number of scenarios, including a baseline (current practice) scenario against which all other scenarios are compared. For more information about costing, please see DCN 01093, Section 3.01.

Surface Discharge

Surface discharge is the most common and least costly practice to dispose of CBM-produced water in the Powder River Basin. Controls on the discharge of produced water are often selected and approved by the regulatory agencies based on the quality and volume of water produced. Facilities typically transport the wastewater to the discharge location via buried flowlines. Facilities often use surface discharge in combination with aeration methods to precipitate iron from the water in order to reduce or eliminate staining in the stream beds and preserve the aesthetic quality of the receiving stream. Water typically flows over rip-rap before entering the stream bed to reduce erosion and further precipitate iron from the water. Facilities may also use spray nozzles, educators, and bubble diffusers to aerate the water before discharge.

Storage/Evaporation Ponds

Many CBM operators in the Powder River Basin use unlined earthen storage ponds for evaporation and infiltration in conjunction with surface discharge to minimize the amount of water reaching outfalls to surface water. Ponds are typically constructed by excavating a rectangular pit with sloped sides and berms around the perimeter. Water is eliminated via infiltration, evaporation, and transport to irrigated cropland and pasture land without return flows to drainages.²⁷ Evaporation rates depend largely upon the characteristics of the pond. Evaporation from small shallow ponds is usually quite different than from large reservoirs due to the differences in heating and cooling rates of the water. In semi-arid regions such as Wyoming, hot dry air moving from a land surface over a water body will result in higher evaporation for smaller water bodies.²⁸

Two types of storage ponds are used: in-channel and off-channel. In-channel ponds are located within an existing drainage basin, including all perennial, intermittent, and ephemeral defined drainages, lakes, reservoirs, and wetlands. Off-channel ponds are located on upland areas, outside of natural drainages and alluvial deposits associated with these natural drainages.²² Most of the storage ponds in the Powder River Basin are off-channel and are designed to contain all CBM-produced water without discharge to Class 2 waters.²³

²⁷ O&G Environmental Consulting. 2002. Coalbed methane producers information survey results. O&G Environmental Consulting, Englewood, CO. January.

²⁸ Pochop, L., K. Warnaka, J. Borrelli, and V. Hasfurth. 1985. Design information for evaporation ponds in Wyoming. WWRC-85-21. See: www.wrds.uwyo.edu/library/wrp/85-21/85-21.html.

When groundwater and soil contamination from lower quality CBM-produced water are a concern, impervious barriers or liners can be used to reduce seepage through the pond bottom and sides. Soil that is at least 10 percent clay can be compacted with a sheepsfoot roller to create a suitable impervious barrier. If the soil is not at least 10 percent clay, a liner or soil amendment could be used to achieve impermeable barrier restrictions. The following site conditions may also require seepage reduction beyond what is provided by compacting the natural soil: a shallow underlying aquifer, an underlying aquifer that is ecologically important or used as a domestic water source, or highly permeable underlying bedrock or soil. Three options are available to provide additional seepage reduction: the soil can be mixed with bentonite or a soil dispersant and then compacted; clay can be imported and compacted along the bottom and side walls; or concrete or synthetic materials such as geomembranes or geosynthetic liners can be used. Concrete and synthetic liners are usually the most expensive. The method chosen to line the pond depends on the type of soil, site geography and location, available materials, and costs of alternatives. Ponds with liners, however, will have to be significantly larger than unlined ponds because no infiltration into the substrate occurs. Evaporation becomes the only mechanism for reducing the water levels in these lined, impermeable storage ponds.

Injection

Injection of produced water from oil and gas operations into Underground Injection Control (UIC) Class II wells is the predominant (greater than 90 percent by volume) form of produced-water management in the continental United States.²⁹ Class II wells are regulated by the UIC and are used to inject fluids associated with the production of oil and natural gas. Injection into UIC Class II wells is also the predominant disposal option for CBM-produced water in the San Juan Basin because of high TDS.

An injection well may be installed by either drilling a new hole or by converting an existing well. The types of existing wells that may be converted include: marginal oil-producing wells, plugged and abandoned wells, and wells that were never completed (dry holes). Drilling a new injection well may be similar to drilling a CBM-production well except that injection wells may need to be drilled deeper.

In the conventional oil and gas industry, well conversions are most commonly performed as part of an enhanced recovery (water flood) project, and on wells whose hydrocarbon production rates have or soon will diminish to the point where they are no longer economical to operate as production wells (i.e., they have been depleted). Wells that were never completed (dry holes) and old plugged and abandoned wells may also be used, but may require more work at greater expense.³⁰ The most common method of conversion involves recompleting

²⁹ Lawrence, A.W. 1993. Coalbed methane produced-water treatment and disposal options. Quarterly Review of Methane From Coal Seams Technology 11:2. Gas Research Institute. December.

³⁰ Wyoming Department of Environmental Quality. No date. Draft recommended off-channel, unlined CBM produced water pit siting guidelines.

the well at a shallower depth into a nonhydrocarbon-producing formation. In such a case, the lower portion of the well is cemented and sealed off.

Some of the technical issues that may be associated with subsurface injection of produced water include formation plugging and scaling, formation swelling, corrosion, and incompatibility of injected produced waters with receiving formation fluids. In general, these issues can be avoided or remedied through engineering and operational applications such as the use of treatment chemicals.³¹

An advantage of using Class II injection wells for disposal of CBM-produced water is that the water is returned to a geologic zone in which the natural quality of the water is usually worse than the injected produced water. If the well is properly designed, maintained, and operated, there is little risk of ground-water contamination from produced water. A potential disadvantage of using Class II injection wells is the possible need for pretreatment to prevent plugging of the injection well. It is also necessary to periodically clean crusted material from the injection well perforations. Well cleanings require temporary suspension of injection operations, and nearby temporary storage or alternative disposal facilities.³²

Pretreatment may include removing iron and manganese by precipitation. Iron and manganese form oxides upon exposure to air, which may lead to clogging in the well. Settling tanks with splash plates are used to aerate the produced water, which will oxidize iron and manganese to insoluble forms that can precipitate in the tank. The water can then be injected. Biocides may also be added to the produced water prior to injection to control biological fouling.

Iron Oxidation

CBM-produced water often has a high concentration of iron (e.g., 2 mg/L), which can be treated by exposing the water to air. As the water mixes with air, ferric/ferrous iron is oxidized to the ferrous/ferric state and precipitate out as a red/orange solid. Iron oxidation, however, can cause aesthetic problems when the produced water is discharged. To prevent this problem, iron oxidation can be enhanced before the discharge point by using simple oxidation methods such as spray nozzles, educators, bubble diffusors, and surface aerators to help oxygenate the water and precipitate the iron before the CBM effluent stream reaches surface waters. Chemical oxidation methods may also be used to remove iron. CBM operators in the Powder River Basin often use iron oxidation methods to eliminate staining of the receiving streams.

³¹ U.S. EPA. 1996a. Development document for final effluent limitations guidelines and standards for the coastal subcategory of the oil and gas extraction point source category. EPA/821/R-96/023. Washington, DC.

³² Zimpfer, G.L., E.J. Harmon, and B.C. Boyce. 1988. Disposal of production waters from oil and gas wells in the northern San Juan Basin, Colorado. In: Fassett, J.E. Fassett, ed. Geology and coal-bed methane resources of the northern San Juan Basin, New Mexico and Colorado, 1988 Coalbed Methane Symposium. Denver, CO: Rocky Mountain Association of Geologists. pp. 183-198.

Reverse Osmosis

Reverse osmosis is a pressure-driven membrane separation process that can separate dissolved solutes from a solvent, usually water. The solute may be organic or inorganic and range in size from 1 to 10 Angstroms or less. Reverse osmosis membranes may consist of cellulose acetate, polyamides, or other polymers. The ability of reverse osmosis membranes to reject organic substances depends upon the molecular weight, geometry of the solute, and other factors. A well-designed reverse osmosis system can remove 90 to 99 percent of most dissolved organic and inorganic compounds. Most current reverse osmosis applications are related to water treatment for commercial, industrial, municipal, agricultural, and military facilities.³³

The process of reverse osmosis is based on the principal that when a salt solution is separated from demineralized water by a semipermeable membrane, the higher osmotic pressure of the salt solution causes demineralized water to flow into the salt solution compartment. Water will continue to flow and rise in the salt solution compartment until the increase in water height equals the osmotic pressure of the salt solution. If pressure is exerted on the salt solution compartment, water can be made to flow in the reverse direction; this is called osmotic pressure. Other membrane separation processes, such as microfiltration, nanofiltration, and ultrafiltration, use physical separation of solutes and all insoluble compounds based on membrane pore size, not osmotic pressure.

In a typical reverse osmosis system, a pump applies pressure to the feed stream (e.g., CBM-produced water) to move water from the more concentrated to the less concentrated side of a membrane. The influent stream is separated into a permeate stream of treated water and a reject stream containing the concentrated salts. The reject stream is often disposed of through deep well injection and the permeate stream is often surface discharged.

The greatest challenge in constructing a reverse osmosis system is packaging the greatest area of a fragile membrane in a relatively inexpensive housing that can operate at differential pressures of up to 1,000 psig. Two element designs, spiral wound elements and hollow fine fiber elements, have been developed to address this challenge. The spiral wound element consists of two sheets of membrane separated by a porous support material. This material supports the membrane against the operating pressure and provides a flow path for the product water. This unit is sealed around three sides with glue while the fourth edge is sealed to a hollow plastic tube that has perforations inside the edge seal area so that product can be removed from the porous support material. The units are rolled up about the central tube along with a mesh spacer that separates the membrane surfaces and promotes turbulence of the feed water as it passes through the element. Up to six elements may be connected in series and housed in a single pressure vessel.²⁸ Reverse osmosis units can be constructed on mobile platforms to allow operators to relocate the units after water production declines in any particular area.

³³ Desalination Systems, Inc. 1986. Technical bulletin: reverse osmosis fundamentals. Desalination Systems, Inc. October.

The most critical problem confronting operators of reverse osmosis systems is fouling. Foulants consist of four major classes of substances: metal hydroxides (e.g., iron, manganese, aluminum hydroxides); colloidal and particulate foulants; precipitates of sparingly soluble salts (e.g., calcium carbonate, calcium sulfate); and biological or organic foulants (e.g., bacteria, bacterial by-products). Colloidal and metal hydroxide foulants enter in the feedwater and are driven to membrane surfaces by the permeate flow. Organic foulants and bacteria also enter in the feedwater. Given a suitable substrate, bacteria are capable of attaching and growing on membrane surfaces. Precipitates form when the solubility of sparingly soluble salts is exceeded within the system.²⁸

Membrane cleaning is usually effective in removing the majority of foulants, but it is not 100 percent effective in removing all foulant deposits and some cleaners may, with frequent use, cause a loss in salt rejection. However, with adequate pretreatment, reverse osmosis systems should not have to be cleaned more than several times per year and membranes should last approximately three years.²⁸

Although reverse osmosis has not often been used to treat large amounts of CBM-produced water for high TDS content, it has been and continues to be pilot-tested by CBM operators and is currently being used in Utah. Talon Resources is currently operating a reverse osmosis treatment unit in the Ferron Coalbed Gas Fairway in Orangeville, Utah. This unit is processing about 15,000 gallons of CBM-produced water per day and surface discharging about 10,000 gallons per day. In the San Juan Basin, Phillips installed a reverse osmosis system at a pilot plant in 1992 at Pump Mesa. The pilot plant operated for only two months and was shut down due to delays in obtaining a surface discharge permit.³⁴ BP is currently working with US Filter and Hydrometrics to develop pilot-scale reverse osmosis treatment. Pilot tests are also expected to begin in the Powder River Basin.

Ion Exchange Technology

The Higgins Loop ion exchange system uses cation and/or anion resins to remove sodium, chloride, sulfate, and other ions from CBM water. The CBM water must be degassed of methane prior to entering the system facility for personal safety reasons. This can be accomplished using a gas separator or a small receiving pit. The CBM water enters a small influent tank used as a feed tank to the system. Once the water enters the system, it moves through the adsorption zone, where a strong acid cation exchange resin (Dow G-26 resin) is used to remove the cations from CBM water. The cations in the CBM water are replaced by hydronium ions from the resin beads. This lowers the pH level of the CBM water and bicarbonate ions begin to react with the hydronium ions to form carbon dioxide gas. The treated water is then discharged to a neutralizing bed where the excess hydronium ions and residual bicarbonate ions (or carbon dioxide gas in solution, depending the pH) can react with selected calcium minerals to achieve the desired final pH. The selection of the neutralizing agent varies

³⁴ Cox, D.O., A.D. Decker, and S.H. Stevens. 1993. Analysis of fruitland water production treatment and disposal, San Juan Basin. Prepared by Advanced Resources International, Inc., for Gas Research Institute. June.

with the desired final pH and the intended use of the treated water. Typically, limestone is used as the neutralizing agent.³⁵

As the CBM water is being treated, cations are removed from the resin in the regeneration section of the system. Hydrochloric or sulfuric acid is injected into the system, which moves countercurrent to the resin. This regeneration process restores the resin to its hydronium form. The hydrochloric acid is transported to the treatment facility and stored in poly tanks designed for hydrochloric acid containment and have a vapor scrubber in line. A chemical feed pump is used to pump the hydrochloric acid into the ion exchange system. Once the acid enters the system, it is diluted down to 14 percent and introduced directly into the regeneration phase of the system. The regenerated resin is rinsed with water to remove any residual acid before reentering the adsorption zone. This process generates a concentrated brine, which is removed for disposal.³⁰

The concentrated brine volumes range from 0.8 percent to 2 percent of the influent CBM water volume, depending on the cation loading that is removed from the treated water. The concentrated brine is typically stored on site until there is enough for a truck load. Then, it is transported to a commercial disposal facility, where it is disposed using an injection well.³⁰

As the upper layer of the adsorption zone becomes loaded with sodium, the ion exchange system is designed to interrupt the flow to the system to allow the resin to pulse in the opposite direction of the water flow. Once the resin pulsing is completed, the water flow into the system is restarted. In addition, the system is designed to backwash any solids out of the resin. The solids and small amounts of resin are backwashed into the resin recovery tank. Periodically, the operator will remove the resin from this tank and add it back into the system. If silts accumulate in the resin recovery tank, the operator removes them.³⁰

This system is effective at reducing total dissolved solids (TDS) levels of 1,600 to 1,800 milligrams per liter (mg/L) to below 500 mg/L. The limitations of the system are determined by the total cation load of the CBM water. The system is engineered to operate at optimum with cation levels at a sodium equivalency of 500 mg/L but is efficient to any level below 500 mg/L and up to levels above 1,500 mg/L. The life span of the ion exchange system is typically 15 to 20 years. The system is capable of treating CBM water with 13 percent solids; therefore, pretreatment is not required.³⁰

The Higgins Loop™ has been a viable system for many years and has a history of 97 percent or greater up time or continuous runtime. The design of the system allows for most of the required maintenance (e.g., replacement of small control valves) to be replaced during operation. Most of the down time that has been experienced is related to temperature generator power failure.³⁰

³⁵ EMIT (2003), Report on Coal Bed Natural Gas Produced Water Treatment Utilizing Continuous Countercurrent Ion Exchange (CCIX) Technology. EMIT Water Discharge Technology, LLC. September.

Electrodialysis

Electrodialysis is a membrane technology that can remove ionic constituents in CBM- produced water. In electrodialysis, salts and minerals are removed from a stream of saline water through special plastic membranes by the action of a direct electrical current. These salts and minerals pass through the membrane in the form of positively and negatively charged ions. The water from which these ions have been removed flows between the membranes and is collected as a partially demineralized product by manifolds cut through the membranes. The salts and minerals removed from the product stream pass through the membranes into another stream of water that continuously washes the other side of each membrane and emerges through manifolds as a more concentrated waste stream. The amount of electrical current and membrane surface required to desalt a given quantity of water by electrodialysis and the cost depends on the amount and type of mineral to be removed.³⁶

An electrodialysis cell consists of alternating anion-permeable and cation-permeable membranes that form compartments. Cations pass through the cation-permeable membrane toward the cathode and are trapped by the membrane, which is permeable only to anions. The anions travel in the opposite direction toward the anode and are trapped by the cation-permeable membrane. The feed stream becomes depleted of ions as they become trapped between the anion- and cation-specific membranes.

Although electrodialysis is technically capable of treating CBM-produced water with a high TDS content, no commercial applications of this technology are known for treating this type of wastewater.

Precipitation

Chemical precipitation is a separation technology in which adding chemicals during treatment causes insoluble solid precipitates to form from the organic or inorganic compounds in the wastewater. Chemical precipitation is generally carried out in four phases: (1) addition of the chemical to the wastewater; (2) rapid (flash) mixing to distribute the chemical evenly into the wastewater; (3) slow mixing to promote growth by various flocculation mechanisms; and (4) filtration to remove the flocculated solid particles. Precipitation is caused by adding chemical reagents that adjust the pH of the water to the minimum solubility of the metal. The standard reagents include lime (calcium hydroxide), caustic (sodium hydroxide), magnesium hydroxide, soda ash (sodium carbonate), trisodium phosphate, sodium sulfide, and ferrous sulfide. These reagents precipitate metals as hydroxides, carbonates, phosphates, and

³⁶ Corbitt, R.A. 1990. Standard handbook of environmental engineering. New York: McGraw-Hill, Inc. R.R. Donnelley & Sons Company.

sulfides. Metals commonly removed from solution by precipitation include arsenic, barium, cadmium, chromium, copper, lead, mercury, nickel, selenium, silver, thallium, and zinc.³⁷

In a typical precipitation process, a chemical precipitant is added to the metal-containing water in a stirred reaction vessel. The dissolved metals are converted to an insoluble form by a chemical reaction between the soluble metal and the precipitant. The suspended particles are then flocculated and either settled in the batch tank or passed to a membrane filter. Granular media filtration can be used to remove any suspended metal precipitates that do not settle in the reaction tank.

Hydroxide precipitation is the most common type of chemical precipitation. Hydroxide precipitation normally uses calcium hydroxide (lime), sodium hydroxide (caustic), or magnesium hydroxide as a precipitant to remove metals as insoluble metal hydroxides. The effluent metals concentration achieved by hydroxide precipitation depends upon the metals present, precipitant used, the reaction conditions (especially pH), and the presence of other materials that may inhibit precipitation. Hydroxide precipitation can achieve effluent metal concentrations of less than 1 mg/L, and sometimes less than 0.1 mg/L. The solubility of the metal is directly related to the pH of its environment. Many metals can form low solubility hydroxides in the pH range of 8.5 to 11.5. Removal of precipitated metals typically involves adding flocculating agents or polymers to destabilize the hydrodynamic forces that hold the particles in suspension.³²

CBM operators are not currently using chemical precipitation to treat produced water. This technique, however, could be combined with another treatment option if metal contaminants in the water are identified as a problem.

Downhole Gas/Water Separation

Downhole gas/water separation (DGWS) is an emerging technology for managing and disposing of produced water. This type of technology separates the water and gas below the surface and disposes of the water in a nonproduction zone without bringing the water to the surface. DGWS can reduce produced water management costs and increase the productive life and profitability of a well. This technology is not currently being used by CBM operators.

DGWS requires a disposal zone that is isolated from the production zone so that the injected water will not interfere with gas production. The disposal zone must also be capable of handling the quantities of water pumped during gas production. A study of DGWS by Radian International³⁸ that looked at 53 DGWS installations in conventional gas fields in the United

³⁷ U.S. EPA. 2000a. Development document for the proposed effluent limitations guidelines and standards for the iron and steel manufacturing point source category. EPA/821/B-00/011. Washington, DC. December.

³⁸ Gas Technologies Information. 1999. Technology Assessment and Economic Evaluation of Downhole Gas/Water Separation and Disposal Tools. GRI-99/0218, report prepared for the Gas Research Institute by Radian International.

States and Canada showed mixed results. Poor performance was due to low injectivity in the disposal zone, insufficient zone isolation (recycling the water through the production zone), and poor well-bore integrity. Additional studies show that DGWS systems perform better when installed in a well with a competent cement sheath, minimal sand production, soft water, water production of at least 25 to 50 barrels per day, disposal costs of greater than \$25 to \$50 per day, and a low-pressure, high-injectivity disposal zone below the producing interval.³⁹

Freeze-Thaw/Evaporation Process

Freezing is a crystallization process that can be used to purify water. When salts or other constituents are dissolved in water, the freezing point of the solution is lowered below 32°F, the freezing point of pure water. Partial freezing occurs when the solution is cooled to a point below 32°F but still above the freezing point of the solution. At this point, relatively pure ice crystals form, along with an unfrozen brine. The brine has a higher density than the ice and is readily separated. The relatively pure water that results when the ice melts can be directly utilized for a variety of beneficial uses, or discharged with a NPDES permit.⁴⁰

To allow more widespread application, the freezing technique has been coupled with evaporation to allow year-round application. Although EPA does not endorse any specific technology or vendor, the U.S. Department of Energy, Gas Research Institute, and several oil and gas operators have been conducting research since 1992 to develop a commercial, natural freeze-thaw/evaporation purification process for produced waters. This technology is being tested as part of an automated produced-water treatment and disposal facility in northwestern New Mexico's San Juan Basin. The tests show that the process has potential in areas where costs for conventional disposal is high or where the treated water or concentrated brine is of value.³⁴ A freeze-thaw/evaporation process is suitable for portions of the country with climates that range below freezing.

Harmon SO₂ Generator

Harmon Systems International, LLC developed an SO₂ generator which can be used to treat CBM production water.^{41,42} The Harmon SO₂ Generator is a sulfur burner that controls and maintains pH, carbonates, bicarbonates, and sodium absorption ratio (SAR) in water and soil. The system oxidizes sulfur into sulfur dioxide gas (SO₂) by burning elemental sulfur with a propane torch in the presence of pressurized water and air. The sulfur dioxide gas is combined with the CBM produced water to produce sulfurous acid (H₂SO₃). Sulfurous acid

³⁹ Rudolph, J. 2001. Downhole produced water disposal improves gas rate. GasTIPS 7(3).

⁴⁰ Gas Research Institute. 1997. Treating produced waters in the San Juan Basin with the freeze-thaw/evaporation process. See: www.gri.org.

⁴¹ Memorandum from Gong, T.R. of Harmon Systems International to Carey Johnston of EPA. May 19, 2004.

⁴² Harmon Systems International, LLC website. See: <http://www.harmonso2generators.com>.

neutralizes the buffering effects of bicarbonates and carbonates in the water, reducing the alkalinity of the water. The water produced as a result of this process is slightly acidic, similar to rain water, and can be land applied as irrigation for crops. Since the alkalinity of the water has been lowered, and bicarbonates and carbonates have been reduced, lime will no longer form in the soil. Also, additional acidity can be released as the water reacts with bacteria, organic matter, and dissolved oxygen in the soil. This additional acidity allows lime native to the soils to dissolve and promote deeper water infiltration in the soil. Salts leach to deeper depths, preventing salt accumulation on the surface soil.

Summary

At this time, EPA concluded it should not identify this industry for an effluent guidelines rulemaking. EPA is developing a guidance document for its permitting responsibilities on Indian lands in Region 8. This guidance will be available for state permitting authorities to consider using in their permitting efforts. EPA believes that, at this time, the best approach to controlling pollutant discharges from CBM operations is through use of this guidance document. This approach will allow EPA to gather additional data on this industry in order to better assess the hazards and risks associated with these discharges. The guidance document might also result in pollutant reductions in the near term as compared to pollutant reductions that may occur at the end of an effluent guideline rulemaking, which typically takes three to five years. If EPA receives new information on this industry in the future, it will reconsider this decision as part of future annual reviews.

5.5.9.8 References

- 1 U.S. EPA. *Development Document for Interim Final Effluent Limitations Guidelines and Proposed New Source Performance Standards for the Oil and Gas Extraction Point Source Category*. EPA-440/1-76/055-a. Washington, D.C. September 1976.

5.6 Group V Industries

Group V industries are those for which EPA has promulgated new or revised effluent guidelines within the past seven years. EPA suspects that many categories with effluent guidelines that have recently been promulgated, but not yet implemented, will appear on the lists of categories generated in the screening level analysis. In these instances, unless EPA has information indicating that the specific sources that are driving the identification were not addressed by the new guidelines, further study of these categories would not be a priority. Therefore, to focus its inquiry during the 2004 annual review, EPA generally excluded categories for which it promulgated effluent guidelines within the past seven years. EPA chose seven years because of the time it takes for effluent guidelines to be incorporated as enforceable effluent limitations into NPDES permits when they are renewed, which could be up to five years after the effluent guidelines are promulgated. This time period also allows for the pollutant reductions associated with recently-promulgated guidelines to be reflected in discharge monitoring data and

TRI reports, so that the Agency can assess the potential for remaining risks or hazards. Table 5-183 lists the Group V industries.

However, as explained in the Preliminary Effluent Guidelines Plan, in cases where EPA is aware of the growth of a new segment within a category for which EPA had recently revised effluent guidelines, or where new concerns are identified for pollutants discharged by facilities within the industrial category, EPA may review a recently promulgated industrial category. Stakeholders raised issues relating to the Metal Products and Machinery (MP&M) (Part 438), Metal Finishing (Part 433), and Electroplating (Part 413) rulemakings. Finally, Commenters also raised issues on Subparts D and E of the Pulp and Paperboard ELG (Part 430). As a result, EPA reviewed the aforementioned recently promulgated regulations as part of its 2004 review. Each of these are discussed below.

Table 5-183. Effluent Guidelines Recently Established, Revised, or Reviewed

CFR Part	Title	Promulgation Date (FR Citation)	Subparts Established/Revised/Reviewed
451	Aquatic Animal Production	June 30, 2004 (69 FR 51891)	BMPs for Subpart A (Flow-through and Recirculating Systems) and Subpart B (Net Pen) were established for BPT, BAT, and NSPS.
432	Meat and Poultry Products	February 26, 2004	The following subparts were revised: Subparts A-D: Meat First Processors (Non-small) Subparts F-I: Meat Further Processors (Non-small) Subpart J: Independent Renderers Subpart K: Poultry First Processors Subpart L: Poultry Further Processors
438	Metal Products & Machinery	May 13, 2003 (68 FR 25686)	The following subpart was established within this new point source category: Subpart A: Oily Waste The following industry sectors were reviewed: Railroad Line Maintenance Facilities (no effluent guidelines) Shipbuilding Dry Docks (no effluent guidelines) Metal Finishing (Part 433) Electroplating (Part 413)

Table 5-183 (Continued)

CFR Part	Title	Promulgation Date (FR Citation)	Subparts Established/Revised/Reviewed
412	Concentrated Animal Feeding Operations	February 12, 2003 (68 FR 7176)	<p>The following subpart was revised: Subpart A: Horses and Sheep</p> <p>The following subpart was reviewed: Subpart B: Ducks</p> <p>The following subparts were established: Subpart C: Dairy Cows and Cattle Other Than Veal Calves Subpart D: Swine, Poultry, and Veal Calves</p> <p>Note: Subparts C and D were previously included in Subpart A</p>
420	Iron & Steel	October 17, 2002 (67 FR 64216)	<p>The following subpart was established within this existing point source category: Subpart M: Other Operations</p> <p>The following subparts were revised within this existing point source category: Subpart A: Cokemaking Subpart B: Sintering Subpart C: Ironmaking Subpart D: Steelmaking</p> <p>The following subparts were reviewed within this existing point source category: Subpart E: Vacuum Degassing Subpart F: Continuous Casting Subpart G: Hot Forming Subpart H: Salt Bath Descaling Subpart I: Acid Pickling Subpart J: Cold Forming Subpart K: Alkaline Cleaning Subpart L: Hot Coating</p>
434	Coal Mining	January 23, 2002 (67 FR 3370)	<p>The following subparts were established within this existing point source category: Subpart G: Coal Remining Subpart H: Western Alkaline Coal Mining</p>
435	Oil and Gas Extraction	January 22, 2001 (66 FR 6850)	<p>BAT limitations and NSPS for nonaqueous drilling fluids were revised within the following subcategories within this existing point source category: Subpart A: Offshore Subpart D: Coastal</p>

Table 5-183 (Continued)

CFR Part	Title	Promulgation Date (FR Citation)	Subparts Established/Revised/Reviewed
437	Centralized Waste Treatment	December 22, 2000 (65 FR 81242)	The following subparts were established within this new point source category: Subpart A: Metals Treatment and Recovery Subpart B: Oils Treatment and Recovery Subpart C: Organics Treatment and Recovery Subpart D: Multiple Wastestreams
442	Transportation Equipment Cleaning	August 14, 2000 (65 FR 49666)	The following subparts were established within this new point source category: Subpart A: Tank Trucks and Intermodal Tank Containers Transporting Chemical and Petroleum Cargos Subpart B: Rail Tank Cars Transporting Chemical and Petroleum Cargos Subpart C: Tank Barges and Ocean/Sea Tankers Transporting Chemical and Petroleum Cargos Subpart D: Tanks Transporting Food Grade Cargos
444	Waste Combustors	January 27, 2000 (65 FR 4360)	The following subpart was established within this new point source category: Subpart A: Commercial Hazardous Waste Combustor
445	Landfills	January 19, 2000 (65 FR 3007)	The following subparts were established within this new point source category: Subpart A: RCRA Subtitle C Hazardous Waste Landfill Subpart B: RCRA Subtitle D Nonhazardous Waste Landfill
441	Industrial Laundries	August 18, 1999 (64 FR 45072)	The following point source category was reviewed: Facilities that launder industrial textile items from off site as a business activity.
439	Pharmaceutical Manufacturing	September 21, 1998 (63 FR 50388)	The following subparts were revised within this existing point source category: Subpart A: Fermentation Products Subpart B: Extraction Products Subpart C: Chemical Synthesis Subpart D: Mixing/Compounding and Formulation

CFR Part	Title	Promulgation Date (FR Citation)	Subparts Established/Revised/Reviewed
430	Pulp, Paper, and Paperboard	April 15, 1998 (63 FR 18504)	The following subparts were revised within this existing point source category: Subpart B: Bleached Papergrade Kraft and Soda Subpart E: Papergrade Sulfite

5.6.1 Metal Products and Machinery, Metal Finishing, and Electroplating (Parts 438, 413, and 433)

5.6.1.1 Background

The metal finishing effluent guidelines (40 CFR Part 433) were promulgated in 1983 and regulate a wide variety of industries performing various metal finishing operations. EPA estimates that there are approximately 44,000 facilities performing various metal finishing operations that discharge process wastewater directly to surface waters or indirectly to surface waters through POTWs.⁴³ Most of these 44,000 facilities are indirect dischargers and are regulated by the metal finishing effluent guidelines. EPA recently reviewed these effluent guidelines as part of the MP&M effluent guidelines (see May 13, 2003; 68 FR 25686). Due to a variety of factors identified in the preamble to the final MP&M rule, EPA did not revise the metal finishing effluent guidelines.

A number of POTWs and metal finishing facilities suggested in public comments on the Preliminary Plan (see December 31, 2003; 68 FR 75515) that iron phosphate conversion coating should be excluded from the list of core operations in the metal finishing effluent guidelines. Phosphate conversion coating is defined as a “core” operation under the metal finishing effluent guidelines (Part 433.10(a)). Facilities that perform a core operation are subject to the metal finishing effluent guidelines. Consequently, metal finishing facilities performing phosphate conversion coating operations are currently subject to the metal finishing effluent guidelines.

The metal finishing effluent guidelines do not distinguish among the various types of phosphate conversion coating operations (e.g., iron, zinc, nickel). All phosphate conversion coating operations are regulated as a “core” operation under the metal finishing effluent guidelines (Part 433.10(a)). However, some phosphate conversion coating baths contain high concentrations of toxic metals (e.g., zinc or nickel) while other phosphate conversion coating processes use a phosphoric acid or phosphate salt solution that contain much lower concentrations of toxic metals. The rinses from iron phosphate conversion coating operations contain very low concentrations of toxic metals and are often well below the metal finishing effluent guidelines.

⁴³Metal Products and Machinery Final Rule, Technical Development Document, EPA-821-B-03-001, Page 4-2.

5.6.1.2 Public Comments

A number of POTWs and metal finishing facilities suggested in public comments on the Preliminary Plan that iron phosphate conversion coating should be excluded from the list of core operations in the metal finishing effluent guidelines. Commenters cite EPA's more recent MP&M rulemaking record (including analytical wastewater sampling data) that identifies iron phosphate conversion coating as an industrial operation with low concentrations of metals. EPA documented for the MP&M rulemaking that iron phosphate conversion coating does not require metals treatment (e.g., chemical precipitation and settling) and can be adequately treated by oily wastewater treatment (e.g., emulsion breaking and oil-water separation).

Commenters cited several benefits for taking such an action. First, commenters suggest a pollution prevention benefit. If EPA were to exclude iron phosphate conversion coating from the list of regulated "core" operations under the metal finishing effluent guidelines, some metal finishing facilities might wish to lower their monitoring and record-keeping costs and switch from zinc or nickel phosphate conversion coating to iron phosphate conversion coating. This switch would have an added benefit of potentially reducing metals discharges. Second, commenters suggest that revising the list of core metal finishing operations might help lower the oversight burden for POTW pretreatment control program and focus more of their inspection and monitoring budgets on facilities with higher toxic pollutant loadings. The third benefit identified by commenters is that POTWs would not necessarily be required to develop a pretreatment control program if they accept iron phosphate conversion coating wastewaters. Commenters suggest that this may help focus more attention on facilities with higher toxic pollutant loadings and help lower the state and EPA oversight burden of POTW pretreatment control programs.

5.6.1.3 EPA Review of Available Data

EPA attempted to quantify the number of metal finishing facilities that perform iron phosphate conversion coating and whether the wastewaters from these facilities are directly or indirectly discharged to surface waters. EPA reviewed unit processes (UP) data from the MP&M database to answer the following questions:

1. What are the national estimates of direct and indirect discharging facilities subject to metal finishing and/or electroplating (Part 413 or 433) performing: (1) iron phosphate conversion coating; and (2) other phosphate conversion coating (e.g., zinc, nickel)?
2. What are the national volume estimates of wastewater (MGY) associated with the following operations: (1) iron phosphate conversion coating; and (2) other phosphate conversion coating (e.g., zinc, nickel)?
3. What are the national estimates of POTWs accepting wastewaters from: (1) iron phosphate conversion coating; and (2) other phosphate conversion coating (e.g., zinc, nickel)?

There were significant data limitations in reviewing MP&M data. Specifically, only 5 of the 196 MP&M survey sites performing conversion coating without chromium (UP-14) responded in a way that allowed EPA to differentiate between iron phosphate conversion coating and other types of phosphate conversion coating. All five of these MP&M survey sites are indirect dischargers. EPA estimates that some of the remaining 191 sites also perform iron phosphate conversion coating. Consequently, the answers to the above three questions are provided below as a ranges.

National Estimates of Metal Finishers Performing Conversion Coating Without Chromium

Using information from the 196 MP&M survey sites, EPA estimates that nationally there are 3,617 facilities regulated by either Part 413 or 433 that perform conversion coating without chromium (UP-14). Of these 196 survey sites, 180 are indirect dischargers and 16 are direct dischargers. EPA estimates that these 180 and 16 survey sites represent national estimates of 3,420 indirect dischargers and 197 direct dischargers, respectively. As previously stated, none of the five MP&M survey sites clearly identified as performing iron phosphate conversion coating were direct dischargers. However, it is possible that some of the 16 survey sites (197 national estimate) perform only iron phosphate conversion coating. Using information from the 180 indirect discharging MP&M survey sites, the national estimate of metal finishing indirect dischargers performing iron phosphate conversion coating ranges between 213 and 3,420 facilities.

National Volume Estimates of Wastewater

For both direct and indirect dischargers at the national level (3,617 facilities), EPA estimates 6,100 MGY of process and rinse wastewater are generated from conversion coating without chromium (UP-14). Using information from the 180 indirect discharging MP&M survey sites, the national wastewater estimate from metal finishing indirect dischargers performing iron phosphate conversion coating ranges between 96 MGY and 6,100 MGY. EPA was unable to estimate the national wastewater estimate from metal finishing direct dischargers performing iron phosphate conversion coating, as EPA did not clearly identify any metal finishing direct dischargers performing iron phosphate conversion coating.

National Estimates of POTWs Accepting Conversion Coating Without Chromium Wastewater

To estimate the number of POTWs accepting wastewater from iron phosphate conversion coating operations, EPA used a conservative assumption that each metal finisher discharges to a separate POTW (i.e., one POTW per metal finisher). This assumption will likely overestimate the number of POTWs accepting wastewater from iron phosphate conversion coating operations but does help provide an upper bound estimate. Using information from the 180 indirect discharging MP&M survey sites, the national estimate of POTWs accepting

wastewater from iron phosphate conversion coating operations ranges between 213 and 3,420 POTWs.

5.6.1.4 Conclusions

As previously stated, EPA did not clearly identify any metal finishing direct dischargers perform iron phosphate conversion coating. However, it appears that most metal finishing facilities performing iron phosphate conversion coating are indirect dischargers. Consequently, EPA will address the issue of iron phosphate conversion coating and potential revisions to the Metal Finishing (Part 433) effluent guidelines in its CWA Section 304(g) pretreatment standards planning process.

5.6.2 **Pulp and Paperboard (Part 430)**

5.6.2.1 Technology Basis for Phase I

EPA promulgated effluent limitations guidelines and standards for Phase I of the Pulp, Paper, and Paperboard category in 1998. Phase I includes Subpart B, Bleached Papergrade Kraft and Soda, and Subpart E, Papergrade Sulfite. EPA divided Subpart E into three segments. The technology basis of promulgated regulations for the calcium-, magnesium-, or sodium-based sulfite segment was totally chlorine free (TCF) bleaching.

The technology basis of promulgated regulations for Subpart B, Bleached Papergrade Kraft and Soda was elemental chlorine free (ECF) bleaching, consisting of conventional pulping followed by complete substitution of chlorine dioxide for elemental chlorine, as well as the following nine elements:

- (i) Adequate chip thickness control;
- (ii) Closed brownstock pulp screen room operation, such that screening filtrates are returned to the recovery cycle;
- (iii) Use of dioxin- and furan-precursor-free defoamers (i.e., water-based defoamers or defoamers made with precursor-free oils);
- (iv) Effective brownstock washing, i.e., washing that achieves a soda loss of less than or equal to 10 kg Na₂SO₄ per ADMT of pulp (equivalent to approximately 99 percent recovery of pulping chemicals from the pulp);
- (v) Elimination of hypochlorite, i.e., replacement of hypochlorite with equivalent bleaching power in the form of additions of peroxide and/or oxygen to the first extraction stage and/or additional chlorine dioxide in final brightening stages;

- (vi) Oxygen- and peroxide-enhanced extraction, which allows elimination of hypochlorite and/or use of a lower kappa factor in the first bleaching stage;
- (vii) Use of strategies to minimize kappa factor and dioxin- and furan-precursors in brownstock pulp;
- (viii) High shear mixing during bleaching to ensure adequate mixing of pulp and bleaching chemicals; and
- (ix) Efficient biological wastewater treatment, achieving removal of approximately 90 percent or more of influent BOD₅.

EPA considered another technology option, Option B, which was identical to the basis of the promulgated BAT, with the addition of extended delignification (oxygen delignification and/or extended cooking). EPA also considered a TCF option for BAT and NSPS.

EPA determined that no technology option other than the promulgated BAT was both available and economically achievable or resulted in greater reductions in effluent loadings for dioxin, furan and other significant pollutants of concern.

EPA estimated that the cost of the promulgated BAT was \$966 million vs \$2.1 billion for Option B (1995 dollars). EPA estimated the costs for a TCF option ranged from \$3 billion to \$5.6 billion.

EPA concluded that neither Option B nor a TCF option was economically achievable for the Bleached Papergrade Kraft and Soda subcategory as a whole. However, in addition to BAT, EPA promulgated voluntary alternative BAT limitations and PSES based on Option B and TCF bleaching processes in order to encourage mills to use these technologies whenever possible.

5.7 Group VI Industries

Group VI industries are those that ranked low in terms of potential hazard or risk in EPA's screening-level analysis. In addition, none of these industries were identified by stakeholders during EPA's 2003 effluent guidelines review. For its 2004 effluent guidelines review, EPA considered whether it had any reason to believe that the information it relied upon in its 2003 annual review had changed significantly. EPA determined that it didn't have any reason to believe the information has changed, nor did commenters or stakeholders provide any rationale for revising its earlier conclusions. Therefore, EPA did not conduct any additional analysis with respect to these Group VI industries in its 2004 annual review. Table 5-184 lists the Group VI industries.

Table 5-184. Low Ranked Industries Not Identified by Stakeholders

Industrial Category	40 CFR Part	TRI TWPE	TRI Point Source Category Ranking	PCS TWPE	PCS Point Source Category Ranking
Aluminum Forming	467	25,000	19	100,000	11
Asbestos Manufacturing	427	6	44	N/A	N/C
Battery Manufacturing	461	8,000	29	0	40
Carbon Black Manufacturing	458	0	45	N/A	N/C
Cement Manufacturing	411	11,000	26	15,000	22
Copper Forming	468	22,000	23	5,600	27
Explosives Manufacturing	457	381	35	5,600	28
Ferroalloy Manufacturing	424	22,000	22	8,800	24
Glass Manufacturing	426	1,900	31	0	42
Grain Mills Manufacturing	406	8,900	28	479	35
Gum and Wood Chemicals	454	50	39	42,000	14
Hospitals	460	720	NA	5	NA
Ink Formulating	447	51	38	N/A	N/C
Leather Tanning and Finishing	425	29,000	18	5,500	29
Nonferrous Metals Forming and Metal Powders	471	100,000	12	15,000	23
Paint Formulating	446	920	34	N/A	N/C
Paving and Roofing Materials	443	35	40	710	34
Pesticide Chemicals	455	320,000	8	180,000	9
Photographic	459	N/A	N/C	0	41
Plastic Molding and Forming	463	110,000	10	3,700	31
Porcelain Enameling	466	92,000	13	54,000	13
Rubber Manufacturing	428	170,000	9	8,700	25
Soaps and Detergent Manufacturing	417	360	36	164	37
Sugar Processing	409	280	37	16,000	21

NA - Rank not applicable. Point source category excluded because ELG recently developed.

N/A - Not available.

N/C - Not calculated due to lack of PCS or TRI data.

However, EPA notes that, as part of this review, it considered developing additional subcategories for three of the above regulations: Soaps and Detergent Manufacturing (417), Paint formulating (446), and Ink Formulating (447). As part of its review of OCPSF, EPA reviewed the chemical formulator packaging and repackaging (CFPR) industry. EPA studied this industry in 1997. At the time of that study, EPA included SIC codes 2841, 2851, and 2893

because a portion of the facilities reporting these SIC codes are not specifically included in existing applicabilities of Parts 417, 446, or 447 and could be considered part of the CFPR industry. Due to data limitations, EPA had no way to differentiate facilities that were included in existing point source categories and facilities that were part of CFPR. Therefore, EPA included all facilities reporting SIC codes 2841, 2851, and 2893 in the 1997 CFPR study. However, for this review, EPA considered any operations outside of the current applicability of existing effluent guidelines as potential new subcategories of the respective category. Consequently, these SIC codes were included in the review of Parts 417, 446, and 447 and not considered part of the CFPR industry evaluated as part of the OCPSF review.

EPA notes that the total TWPE estimates for Parts 417, 446, and 447 include all facilities that report SIC codes 2841, 2851, or 2893, respectively. Therefore, the TWPE estimates for these categories include discharges from facilities that may not be specifically included in the existing applicabilities of Parts 417, 446, and 447. As indicated above, even with these potential new facilities, these categories rank low in terms of potential toxic wastewater pollutant indicating additional subcategorization is not warranted. EPA recommends permit writers subject such facilities to the applicable existing limitations on a BPJ basis. Permit writers may also want to review and consider pollution prevention alternatives described in EPA's *Pollution Prevention (P2) Guidance Manual: Implementing the P2 Alternative* (EPA-821-B-98-017, June 1998) developed for Pesticide Formulating Packaging and Repackaging (PFPR) facilities. Because many of the operations and wastewater sources at these facilities are similar to those at PFPR facilities, EPA believes the pollution prevention practices identified for PFPR facilities may also be applicable.

Medical and Dental Laboratories

Stakeholders in previous outreach identified independent and stand alone laboratories for new ELG development. This industry may be identified by various SIC codes including 8071, 8072, 8731, and 8734. The SIC code description for each is described below:

- SIC code 8071: *Medical Laboratories*. Establishments primarily engaged in providing professional analytic or diagnostic services to the medical profession, or to the patient on prescription of a physician.
- SIC code 8072: *Dental Laboratories*. Establishments primarily engaged in making dentures, artificial teeth, and orthodontic appliances to order for the dental profession. Establishments primarily engaged in manufacturing artificial teeth, except to order, are classified in SIC code 3843, and those providing dental X-ray laboratory services are classified in SIC code 8071.
- SIC code 8731: *Commercial Physical and Biological Research*. Establishments primarily engaged in commercial physical and biological research and development on a contract or fee basis. Noncommercial research establishments funded by endowments, grants, or contributions

are classified in SIC code 8733. Separate establishments of aircraft, guided missile, or spacecraft manufacturers primarily engaged in research and development on these products are classified in Manufacturing, SIC Major Group 37.

- SIC code 8734: *Testing Laboratories*. Establishments primarily engaged in providing testing services. Establishments primarily engaged in performing clinical laboratory testing for the medical profession are classified in SIC code 8071.

EPA reviewed the applicability of existing ELGs to determine if discharges from stand-alone and independent laboratories were already subject to existing ELGs. EPA found that there are no ELGs that currently apply to discharges from stand-alone and independent laboratories.

Next, EPA evaluated whether discharges from medical laboratory facilities (SIC code 8071) and dental laboratory facilities (SIC code 8072) should be addressed as a potential new subcategory under Hospitals (40 CFR Part 460). Part 460 applies to the wastewater discharges from a variety of activities at hospitals including on-site medical laboratories. Operations included as part of SIC code 8071, medical laboratories, are health care related. Many of the operations present at these facilities are similar to operations present at hospitals (x-rays, blood analysis, etc). Operations classified as part of SIC code 8072, dental laboratories, produce mercury as the main pollutant of concern. Mercury is also a pollutant of concern for hospital wastewater. Therefore, EPA determined medical and dental laboratories are appropriately considered as a potential new subcategory of 40 CFR Part 460.

In this review, EPA also considered whether it should consider develop limitations and standards for additional subcategories of this ELG for medical laboratory facilities (SIC code 8071) and dental laboratory facilities (SIC code 8072). EPA concluded it was not appropriate to develop new ELGs for these subcategories because discharges rank low relative to other industrial categories.

SECTION 6 ORGANIC CHEMICALS, PLASTICS, AND SYNTHETIC FIBERS DETAILED REVIEW

6.1 Introduction

EPA selected the Organic Chemicals, Plastics, and Synthetic Fibers (OCPSF) Point Source Category (40 CFR Part 414) for further review because it ranked highest among all point source categories in toxic, priority, and nonconventional pollutant discharges (in pounds) in the screening-level analysis for 2000. Also in the screening-level analysis, EPA found that, by far, the toxic pollutant loadings are driven by three pollutants: polycyclic aromatic compounds (PACs), aniline, and dioxin. EPA reviewed the facilities that reported discharging these pollutants and identified groups of facilities with common manufacturing processes that discharged the same pollutants. In the case of PACs, EPA identified coal tar refiners; for aniline, EPA identified aniline and dye manufacturers; and for dioxin, EPA identified vinyl chloride manufacturers and other organic chemicals manufacturers.

For the detailed review of OCPSF, EPA further verified Toxic Release Inventory (TRI) and Permit Compliance System (PCS) data, collected and analyzed additional industry data, reviewed the existing regulations for this industrial category, and evaluated potential new subcategories to be considered. In addition, for the three groups of facilities identified above, EPA analyzed current discharges, treatment in place, and industry trends.

EPA also analyzed data associated with facilities that formulate, package, and repackage chemicals into products for end use or for further processing to determine if new subcategories of OCPSF should be identified and further studied for this sector.

This section discusses EPA's analysis of the OCPSF category and its conclusions in the following order:

- Section 6.2 discusses data sources used, EPA's verification of the data, and the data source limitations;
- Section 6.3 discusses the OCPSF industry profile and EPA's identification of three focus industries;
- Section 6.4 discusses the current OCPSF effluent limitations guidelines and standards (40 CFR Part 414);
- Section 6.5 discusses other federal regulations affecting OCPSF;
- Section 6.6 discusses EPA's analysis and findings for coal tar refiners;
- Section 6.7 discusses EPA's analysis and findings for aniline dischargers;

- Section 6.8 discusses EPA's analysis and findings for dioxin dischargers;
- Section 6.9 discusses control of dioxin-laden wastewater, including pollution prevention and wastewater treatment technologies;
- Section 6.10 discusses EPA's findings on chemical formulating, packaging, and repackaging (CFPR) operations; and
- Section 6.11 includes the list of references.

6.2 Data Sources

This section discusses the following data sources specifically as they pertain to the OCPSF detailed review:

- Section 6.2.1 discusses TRI data limitations and verification;
- Section 6.2.2 discusses PCS data limitations and verification;
- Section 6.2.3 discusses data obtained from the Chlorine Chemistry Council;
- Section 6.2.4 discusses data obtained from the Vinyl Institute;
- Section 6.2.5 discusses data obtained from EPA's Office of Solid Waste (OSW) rule on chlorinated aliphatics manufacture;
- Section 6.2.6 discusses data obtained from EPA's Office of Air and Radiation (OAR) rule on mercury emissions from mercury cell chlor alkali plants; and
- Section 6.2.7 discusses other sources that EPA used for this review.

Section 4.2 of this Technical Support Document discusses TRI and PCS. Section 4.2.4 discusses the calculation of toxic-weighted pound equivalents (TWPE) for certain data sources.

6.2.1 Toxic Release Inventory (TRI)

All OCPSF facilities that meet the employee criterion (i.e., 10 or more employees) and the chemical threshold(s) must submit reports to EPA's TRI program. Of the 1,570 OCPSF facilities operating in the United States (U.S.) in 2000 (1), 992 (63 percent) reported to TRI in 2000. EPA used data reported to TRI to estimate pollutant loadings and identify treatment in place for this category.

For the OCPSF detailed review, EPA verified TRI data, particularly for those facilities and pollutants with high TWPE. For example, facilities may estimate releases in a number of ways when reporting to TRI. If a chemical is not detected in the effluent, facilities may estimate the discharge by using one-half of the detection limit. This may overestimate the amount of chemical discharged, which particularly affected the amount of PACs discharges reported for the OCPSF industry, as discussed below.

Facilities report some chemicals as groups to TRI, including the 21 chemicals included in the PAC category. Facilities are required to report the combined mass of PACs released to TRI. They do not identify which compounds are released and they do not report releases of individual PAC compounds to TRI. EPA looked to other data sources to identify the individual PACs that may be present in OCPSF discharges. Benzo(a)pyrene was the only PAC reported in PCS by OCSPF facilities. Therefore, to calculate the TWPE of the PACs reported in TRI, EPA used the toxicity weighting factor (TWF) for benzo(a)pyrene to represent all PACs. Because the TWF for benzo(a)pyrene is higher than any other PAC, this represents a worst-case scenario.

Another TRI chemical group that contributes significantly to EPA's estimate of toxic pounds discharged is dioxin. Facilities are required to report the combined mass of dioxin and dioxin-like compounds released, and they are given the opportunity to report a facility-specific congener distribution. The congener distribution provided by the facility represents releases of dioxin to all media (e.g., air and solids) and may not accurately reflect the specific congeners discharged to surface water. Section 6.8 of this section discusses dioxin TWPE for OCPSF Focus Group 3 (Dioxin Dischargers) in more detail. See also Section 4.2.4.2 for a more detailed discussion on dioxins and the calculation of TWPE for dioxin.

To verify the data reported to TRI, EPA performed the following activities:

- Contacted certain facilities to discuss reported discharges, discussed in Section 6.2.1.1;
- Reviewed comments submitted in response to the December 31, 2003 Preliminary Effluent Guidelines Program Plan, FRN FRL-7604-7, discussed in Section 6.2.1.2;
- Removed TWPE from polychlorinated biphenyls (PCBs) and pesticides, discussed in Section 6.2.1.3; and
- Used industry-provided data to compare pollutant discharges, discussed in Section 6.2.4 (Chlorine Chemistry Council Data).

6.2.1.1 Facility-Specific Verification of TRI Data

For facilities that contributed significantly to the overall TWPE estimate for this industry or for facilities for which EPA received specific comment, EPA verified the TRI data.

ExxonChemical reported the following releases of PACs to surface water from its Baton Rouge plant: 1,801 pounds (7.7 million TWPE) in 2000 and 8,324.9 pounds (36 million TWPE) in 2001. EPA contacted ExxonChemical to 1) verify the discharge of PACs for 2000 and 2001 and determine what caused the increase and 2) determine the primary constituents in the PACs discharges from this facility.

As stated in a letter dated August 21, 2003 in response to EPA's questions, ExxonChemical analyzed wastewater samples collected in 2000 and 2001 (see DCN00336) for PACs, but never detected these compounds. Although analytical data demonstrate PACs were not detected in wastewater from this facility, the facility chose to calculate the PAC discharge using one-half of the detection limit for the concentration estimates. As explained in Section 4.2.1, this is consistent with guidance provided by EPA in reporting to TRI.

Based on this information, for the purpose of this analysis, EPA set the PAC pounds released to surface water from ExxonChemical's Baton Rouge plant to zero for 2000 and 2001 in *TRIRelases2000*. (*TRIRelases2000* is the database that EPA created for analyses for the 2004 annual review. Please see Section 4.2.1 of this TSD for more information.)

6.2.1.2 Data Submitted with Comments

EPA published a *Preliminary Effluent Guidelines Program Plan* on December 31, 2003 for public comment. EPA received no TRI-related data from commenters and no comments from facilities requesting corrections to 2000 TRI data. EPA did receive comments that OCPSF facilities reduced their pollutant discharges since 2000, and that 2002 data would more accurately reflect the current discharges. Also, EPA received dioxin data from some facilities in the Chlorine Chemistry Council under the National Program Chemicals Division, which is discussed in Section 6.2.4.

6.2.1.3 Correction for PCBs and Pesticides

For the screening-level analysis, EPA assigned pollutant loadings to point source categories based on the primary SIC code that facilities reported. Facilities might have mainly OCPSF operations, but also some co-located pesticide operations. Some facilities reported discharges of picloram and total carbaryl, but discharges from picloram and total carbaryl manufacturing are subject to Effluent Limitations Guidelines for the Pesticides Chemical Point Source Category (40 CFR Part 455). For the detailed analysis, EPA included the pollutant loads associated with these pesticides with the Pesticide Chemicals category instead of OCPSF.

PCBs are no longer in commerce, and the mass reported discharged to TRI is most likely not being generated by current processes. Therefore, EPA removed all TWPE associated with PCBs in *TRIReleases2000* for this analysis.

6.2.2 Permit Compliance System (PCS)

As explained in Section 4.2.2, states submit data from facilities' discharge monitoring reports (DMRs) to EPA's PCS. The data from each DMR will vary depending on the facility's National Pollutant Discharge Elimination System (NPDES) permit requirements.

Two of the pollutants with the highest TWPE – dioxins and aniline – are not currently regulated by 40 CFR Part 414. Monitoring of these pollutants is not generally required by NPDES permits. Therefore, EPA only has PCS data from facilities where additional state or local limits apply, as discussed in Sections 6.7 and 6.8.

To verify the data reported to PCS, EPA performed the following activities:

- Reviewed comments submitted in response to the December 31, 2003 Preliminary Effluent Guidelines Program Plan, FRN FRL-7604-7, discussed in Section 6.2.2.1, and
- Removed TWPE from polychlorinated biphenyls (PCBs) and pesticides, discussed in Section 6.2.2.2.

6.2.2.1 Data Submitted with Comments

In response to the December 31, 2003 *Preliminary Effluent Guidelines Program Plan*, EPA received a request from the American Chemistry Council (ACC) for corrections to PCS data for the Celanese Acetate LLC plant in Rock Hill, South Carolina (NPDES Permit ID SC0001783). ACC provided information from the facility verifying that all data except for ammonia and two metals (nickel and zinc) were reported as not detected, and that Celanese Acetate previously submitted a request for correction to PCS. In this case, EPA corrected the *PCSLoads2000* database to reflect the facility-verified data.

General Electric and DuPont submitted comments that they generally disagreed with EPA's methodology regarding concentrations measured below detection limits in PCS. The commenters stated that EPA's methodology overestimated PCS loads because of detection limit considerations. For example, as explained in Section 4.2.2, if a facility never detects a pollutant in a year, EPA sets the load to zero for that pollutant in *PCSLoads2000*. However, if a pollutant is detected at any point during the year, EPA calculates annual pollutant loads using the detected values and one half the method detection limit for months with no detects. Although DuPont and General Electric provided qualitative data, they did not provide analytical data to support their assertions. These commenters instead gave general information (e.g., all pollutant loads, except for ammonia and nickel, should be zero for their OCPSF facilities). In these cases, where

companies did not provide specific monitoring data, EPA did not change the *PCSLoads2000* database.

6.2.2.2 Correction for PCBs and Pesticides

For the screening-level analysis, as with TRI data, EPA assigned pollutant loadings to point source categories based on the primary SIC code that facilities reported. Facilities may have mainly OCPSF operations, but also some co-located pesticide operations. Some facilities reported discharges of picloram and total carbaryl, but discharges from picloram and total carbaryl manufacturing are covered by Effluent Limitations Guidelines for the Pesticides Chemical Point Source Category (40 CFR Part 455). For this analysis of PCS data, EPA included the pollutant loads associated with these pesticides with the Pesticide Chemicals category instead of OCPSF.

PCBs are no longer in commerce, and the mass reported discharged to PCS is most likely residual – not being generated by current processes. Therefore, EPA removed all TWPE associated with PCBs in *PCSLoads2000*.

6.2.3 **Economic Census**

The 1997 U.S. Economic Census provides an upper bound on the number of facilities performing operations that fall under the OCPSF category. The census may overstate the number by including nonproduction facilities, such as sales locations. For these reasons, EPA used census data only as a point of reference in the OCPSF detailed review.

6.2.4 **The Chlorine Chemistry Council**

As stated on its web page (<http://www.c3.org>), the Chlorine Chemistry Council (CCC) is a national trade association representing the manufacturers and users of chlorine and chlorine-related products. It is also a business council of the ACC. Members of the CCC provide media-specific data to the public on their dioxin discharges on the CCC web page, in part because the CCC is concerned that TRI reporting requirements overstate the amount of dioxin discharged. As of June 2004, the CCC posts data for 2000, 2001, and 2002.

Facilities provided media-specific dioxin release data to the CCC. The congener distribution can greatly affect the estimated toxicity of a dioxin discharge. For example, the 2,3,7,8-tetrachlorodibenzo(p)dioxin (2,3,7,8-TCDD) congener (TWF = 421,600,000) is much more toxic than the 1,2,3,4,6,7,8,9-octachlorodibenzofuran (OCDF) congener (TWF = 67,367). Also, the congener distribution of dioxin in air can differ greatly from that in water, and the media-specific data can differ greatly from the TRI congener distribution that is intended to apply to all media. EPA revised the TWFs for dioxins in 2004. The memorandum entitled Revisions to TWFs for Dioxin and its Congeners and Recalculated TWPEs for OCPSF and Petroleum Refining (available in the docket) presents the estimated TWPE for OCPSF facilities using the revised TWFs.

For this detailed review, EPA used all available CCC dioxin data, which included facility-specific data from the following companies:

- Dow Chemical;
- Occidental Chemical (as well as joint ventures OxyVinyls and Oxychem);
- PPG;
- Vulcan;
- Formosa;
- Georgia Gulf; and
- Borden Chemicals and Plastics.

In addition, the CCC voluntarily provided more specific, verified dioxin discharge data to EPA's National Program Chemicals Division (NPCD) for the 2000 EPA Dioxin Inventory. Section 6.8, the Dioxin Dischargers section, discusses these data in more detail.

6.2.5 The Vinyl Institute

According to its web site (<http://www.vinylinstitute.org>), the Vinyl Institute is a U.S. trade association representing the leading manufacturers of vinyl, vinyl chloride monomer (VCM), vinyl additives and modifiers, and vinyl packaging materials. The Vinyl Institute published a report entitled, "The Vinyl Institute Dioxin Characterization Program" on July 1, 2002. From this report, EPA identified the facilities that manufacture ethylene dichloride (EDC), VCM, and polyvinyl chloride (PVC). EPA also used data presented in the report from an industry study that tested wastewater from EDC/VCM and PVC manufacturing and PVC resins for dioxin, presented in Section 6.8. The study concluded that PVC products such as pipes do not contain dioxin and are safe to use, but that dioxin may be found in wastewater from EDC, VCM, and PVC manufacture.

6.2.6 Office of Solid Waste Chlorinated Aliphatics Rule

EPA's Office of Solid Waste (OSW) promulgated a hazardous waste rule on Chlorinated Aliphatics Production Wastes on November 8, 2000. As part of the analysis supporting the rulemaking, OSW collected sampling data on six types of waste (19):

- Wastewaters generated from the production of VCM using mercuric chloride catalyst in an acetylene-based process (VCM-A wastewaters, not listed);
- Wastewaters from the production of chlorinated aliphatic hydrocarbons, except for wastewaters generated from the production of VCM using mercuric chloride catalyst in an acetylene-based process (proposed as K173 waste but not listed);
- Wastewater treatment sludges from the production of VCM using mercuric chloride catalyst in an acetylene-based process (listed as K175);

- Wastewater treatment sludges from the production of EDC or VCM (listed as K174);
- Wastewater treatment sludges from the production of methyl chloride (not listed); and
- Wastewater treatment sludges from the production of allyl chloride (not listed).

OSW sampled untreated wastewater effluent at the point of entry into biological treatment for K173 waste (chlorinated aliphatic hydrocarbons). In the Best Demonstrated Available Technology (BDAT) report, OSW presents the results for the plants that had EDC/VCM wastewater (15). EPA used these data in the OCPSF detailed review to determine the source of dioxin in OCPSF wastewater.

6.2.7 Office of Air and Radiation NESHAPs Rule for Mercury Cell Chlor-Alkali Plants

On December 19, 2003, EPA's Office of Air and Radiation (OAR) promulgated National Emission Standards for Hazardous Air Pollutants: Mercury Emissions from Mercury Cell Chlor-Alkali Plants. As part of this rule, OAR collected manufacturing data from chlor-alkali plants in the United States. EPA used the manufacturing information about the chlor-alkali plants in the OCPSF detailed review.

6.2.8 Other Data Sources

In addition to those sources discussed above, EPA also used the following:

- Company web pages available on the Internet;
- The June 2003 Chlorine Institute publication entitled, *North American Chlor-Alkali Industry Plants and Production Data Report*;
- National Safety Council's "Chemical Backgrounders," available via its web site (<http://www.nsc.org>);
- The Innovation Group (TIG) Chemical Profiles, available via its web site (<http://www.the-innovation-group.com/welcome.htm>); and
- Other related web pages available on the Internet, such as news web pages, economic statistics web pages, and state and local regulatory agency web pages.

6.3 General Industry Profile and Identification of Focus Industries

EPA's initial review of the OCPSF category used data from the *Development Document for Effluent Limitations Guidelines, New Source Performance Standards, and Pretreatment Standards for the Organic Chemicals and the Plastics and Synthetic Fibers Point Source Category (October 1987)* (17), the *TRIReleases2000* database, and the *PCSLoads2000* database. Initially, EPA identified OCPSF facilities by their primary SIC code.

As EPA continued its review, it became clear that analyzing discharges by primary SIC code was insufficient to support a detailed review. EPA realizes that the OCPSF category is a large group of many industries. To simplify the review, EPA identified segments of the industry with common processes and/or wastewater characteristics. Next, EPA identified focus industries: those groups of facilities with common manufacturing processes that reported discharge of the pollutants with the highest TWPE. The remainder of this section describes the OCPSF category in general, and the identification of focus industries in the following order:

- Section 6.3.1 presents a general overview of the facilities in the OCPSF category, including the types of products manufactured;
- Section 6.3.2 discusses the manufacturing processes used by OCPSF facilities;
- Section 6.3.3 discusses general wastewater characteristics and treatment;
- Section 6.3.4 discusses the identification of focus industries and SIC code analysis; and
- Section 6.3.5 discusses EPA's decision not to further consider facilities reporting SIC codes 2823 and 2824 in the detailed review.

6.3.1 General Overview of the OCPSF Category

The OCPSF category includes many chemical industries producing hundreds of end products, such as polypropylene, vinyl chloride and PVC, chlorinated solvents, rubber precursors, styrofoam additives, and polyester (to name a few). Some OCPSF facilities are extremely complex and produce hundreds of chemicals, where others are simpler, producing one or two end products (17).

Wastewater discharges from OCPSF operations are regulated under 40 CFR Part 414. In 1989, EPA promulgated Best Practicable Control Technology Currently Available (BPT) for subcategories based on product type, which is similar to the SIC code structure. Table 6-1 lists the subcategories identified for BPT regulation. EPA also promulgated BAT and PSES for subcategories based on type of wastewater treatment, not product type, in Subparts I, J, and K. Section 6.4 discusses the regulation in more detail.

Table 6-1. OCPSF Subcategories for BPT (40 CFR Part 414)

Subpart	Name	Description
A	General	General definitions
B	Rayon Fibers	Manufacture of rayon fiber by the viscose process only
C	Other Fibers	Manufacture of products classified under SIC 2823, except rayon, and SIC 2824 (specific list provided)
D	Thermoplastic Resins	Manufacture of products classified under SIC 28213 - thermoplastic resins (specific list provided)
E	Thermosetting Resins	Manufacture of products classified under SIC 28214 - thermosetting resins (specific list provided)
F	Commodity Organic Chemicals	Manufacture of specific commodity organic chemicals and chemical groups classified under SIC 2865 and 2869 (specific list provided)
G	Bulk Organic Chemicals	Manufacture of specific bulk organic chemicals and chemical groups classified under SIC 2865 and 2869 (specific list provided)
H	Specialty Organic Chemicals	Manufacture of specific organic chemicals and chemical groups not defined as commodity or bulk classified under SIC 2865 and 2869

The OCPSF industry includes establishments engaged in manufacturing organic chemicals, plastics, and synthetic fibers, but does not include rubber manufacturing, gum and wood chemicals manufacturing, pesticide chemicals manufacturing or formulating/packaging/repackaging, or miscellaneous plastics (e.g., plastics molding and forming). Table 6-2 lists examples of chemicals produced by the OCPSF industry.

Table 6-2. Examples of Chemicals Produced by OCPSF Facilities

Organic Chemicals	Plastics and Synthetic Fibers
Derivatives of benzene, toluene, naphthalene, anthracene, pyridine, carbazole, and other cyclic chemical products	Cellulose acetate, phenolic, and other tar acid resins
Synthetic organic dyes and pigments	Urea and melamine resins, vinyl acetate resins, polyethylene resins, polypropylene resins, rosin modified resins
Cyclic (coal tar) crudes, such as light oils and light oil products, coal tar acids, products of medium and heavy oil (e.g., creosote oil), aniline	Cellulosic man-made fibers, including cellulose acetate, rayon, triacetate fiber, styrenes
Noncyclic organic chemicals (e.g., acetic acid, metallic salts, formaldehyde)	Noncellulosic synthetic organic fibers, including acrylic, fluorocarbon, nylon, olefin, polyester, and polyvinyl
Solvents (e.g., amyl, butyl, and ethyl alcohols, carbon disulfide)	Silicones
Polyhydric alcohols and their esters, amines, etc.	Other Products Manufactured from Purchased Refinery Products
Synthetic perfume and flavoring materials	Benzene

Table 6-2 (Continued)

Organic Chemicals	Plastics and Synthetic Fibers
Rubber processing chemicals and plasticizers	Toluene
Synthetic tanning agents	Mixed xylenes
Fatty and other acids	Aliphatic hydrocarbons

The OCPSF category includes the following five SIC codes:

1. *SIC 2821*: Plastic Materials, Synthetic Resins, and Nonvulcanizable Elastomers;
2. *SIC 2823*: Cellulosic Man-Made Fibers;
3. *SIC 2824*: Synthetic Organic Fibers, Except Cellulosic;
4. *SIC 2865*: Cyclic Crudes and Intermediates, Dyes, and Organic Pigments; and
5. *SIC 2869*: Industrial Organic Chemicals, Not Elsewhere Classified.

The organic chemicals sector is geographically diverse, with high concentrations in the Gulf States, Great Lakes area, and New Jersey. For the majority of organic chemicals, production has increased between 2 and 30 percent since 1992. In the synthetic fibers sector, however, cellulosic fiber production has dropped almost 10 percent since 1992. Production of noncellulosic fiber has stayed essentially the same since 1992 (2).

The plastics sector has a presence in every state, but the top 10 states in 2001 accounting for almost 60 percent of employment were: California, Ohio, Michigan, Texas, Illinois, Pennsylvania, Indiana, New York, North Carolina, and Wisconsin (13). The plastics materials and resins industry is concentrated on the Gulf Coast, which has abundant raw materials and an excellent petrochemical infrastructure. Texas tops the list in employment for this sector. Plastics production increased 2 to 3 percent compared to late 1980s and about 5 percent since 1992 (2).

OCPSF facilities reporting to TRI discharge directly and indirectly, and some have zero water discharge. Table 6-3 lists the number of facilities in each SIC code, based on data sources available.

Table 6-3. SIC Codes in OCPSF

SIC Code	1997 U.S. Economic Census	TRI 2000					PCS 2000 Direct (Majors)
		Direct Dischargers	Indirect Dischargers	Both	No Water Discharge Reported	Total Reporting to TRI	
2821	529	93	135	17	218	429	92
2823	6	4	1	1	1	5	4
2824	100	8	7	0	7	22	5
2865	195	36	56	7	22	107	24
2869	740	139	147	24	167	429	118
Total	1,570	280	346	49	415	992	243

6.3.2 OCPSF Manufacturing Processes

Because of the complexity of the OCPSF category, EPA focused the detailed review of manufacturing processes on certain industries. Section 6.3.4 discusses how EPA identified the focus industries. Sections 6.6, 6.7, and 6.8 describe the manufacturing processes of these focus industries. The remainder of this section discusses general production information for the OCPSF category.

OCPSF facilities range in size and production type. Some facilities produce large volumes of chemicals in continuous processes; others produce small volumes of specialty chemicals in batch processes (17). Facilities use a variety of feedstocks and process types. Product mixes may change on a weekly or daily basis, depending on customer specifications (17). Table 6-4 below lists the generic processes used by OCPSF facilities, as identified in the 1987 TDD.

Table 6-4. Examples of Generic OCPSF Processes Identified in the 1987 TDD

Alkoxylation	Amination (ammonolysis)	Phosgenation
Condensation	Nitration	Extraction
Halogenation	Sulfonation	Distillation
Oxidation	Ammoxidation	Hydration
Polymerization	Carbonylation	Hydrodealkylation
Hydrolysis	Hydrohalogenation	Dehydrogenation
Hydrogenation	Dehydration	Catalytic cracking
Esterification	Dehydrohalogenation	Alkylation
Pyrolysis	Oxyhalogenation	Hydrofluorination

OCPSF facilities use feedstock from petroleum refineries, cokemaking plants, pulp mills, and other sources (17). Table 6-5 lists some of the primary feedstocks and associated end products identified in the 1987 TDD.

Table 6-5. Examples of Feedstock and End Products Identified in the 1987 TDD

Example Feedstock	End Product
Benzene	Nitrobenzene, aniline, maleic anhydride, cyclohexane, cyclohexanone, caprolactam, cyclohexanol, adipic acid, cumene, phenol, bisphenol A, acetone, propylene oxide, styrene, ethylbenzene, chlorophenols, chlorobenzenes
Propylene	Polypropylene resins, polypropylene fiber
Cellulose	Rayon fiber, cellulose acetate, cellulose acetate fiber
Ethylene	Ethylbenzene, styrene, acetaldehyde, acetic acid, acetic anhydride, ethylene oxide, ethylene glycol, ethoxylates, EDC, VCM, tetrachlorethylene, carbon tetrachloride, 1,1,1-trichloroethane, ethyl acrylate, ethanol
Methane	Methyl chloride, methylene chloride, chloroform, carbon tetrachloride, methanol, formaldehyde, acetic acid, methyl acrylate, methyl methacrylate
Propylene	Cumene, phenol, propylene oxide, acetone, methacrylic acid, propylene glycol, polyethers, isopropanol, n-butanol, b-butyl acrylate, acrylic acid, n-butyraldehyde, 2-ethylhexanol, 2-ethylhexyl acrylate, allyl chloride, epichlorohydrin, acrolein, allyl alcohol, glycerin, acrylonitrile
Toluene	Dinitrotoluene, toluene diamine, tolylene diisocyanate, trinitrotoluene
Xylenes	Terephthalic acid, dimethylterephthalate

6.3.3 General Wastewater Characteristics and Treatment

This section discusses general wastewater characteristics (Section 6.3.3.1) and wastewater treatment (Section 6.3.3.2) from data provided in the 1987 TDD, the 2000 TRI, and 2000 PCS. Sections 6.6, 6.7, and 6.8 provide more detail on the manufacturing processes and wastewater characteristics of the focus industries.

6.3.3.1 General Wastewater Characteristics

The 1987 TDD contains flow and pollutant information on untreated wastewater. The average per facility flow rate for direct dischargers was 1.31 million gallons per day (MGD), and the average per facility flow rate for indirect dischargers was 0.25 MGD. Table 6-6 presents untreated wastewater concentrations for direct and indirect dischargers.

Table 6-6. Untreated Wastewater Characteristics for Direct and Indirect Dischargers in the OCPSF Category

Pollutant	Raw Pollutant Concentrations (1987)	
	Direct Dischargers (mg/L)	Indirect Dischargers (mg/L)
BOD ₅	1,088	1,784
COD	2,908	4,571
TOC	1,041	973
TSS	579	624
Toxic organic pollutants	See Technical Development Document, Table V-46	

Source: EPA, 1987 TDD, Volume I.

The 1987 TDD linked certain products with the discharge of certain priority pollutants. For example, wastewater sampling data showed that manufacturing acetone from benzene and propylene feedstocks generates aromatic priority pollutants. Table 6-7 lists some additional examples of the types of pollutants found in wastewater from the manufacturing of certain products.

Table 6-7. Examples of Pollutants Discharged from the Manufacturing of Certain Products

Product	Priority Pollutants Detected in Process Wastewater
Acetone	Aromatics
Acrylic fibers	Acrylonitrile
Acrylic resins (latex)	Acrylonitrile, acrolein
Aniline	Aromatics
Caprolactam	Aromatics
Carbon tetrachloride	Chloromethanes, chlorinated C2s
Cellulose acetate	Isophorone
Polyester	Phenol, aromatics
High density polyethylene resin	Aromatics
Methylene chloride	Chloromethanes, chlorinated C2s
Trichloroethylene	Chlorinated C2s, chloromethanes
Toluene (from coal tar light oil)	Aromatics, polyaromatics, phenols, cyanide
Styrene – butadiene resin	Aromatics
Vinyl chloride	Chlorinated C2's, chloromethanes

Source: EPA, 1987 TDD, Volume I.

Notes:

Chlorinated C2s: Long-chain hydrocarbons with 40-49 percent chlorination by weight.

EPA used TRI and PCS data to evaluate annual pollutant loads discharged to surface water, using the methodology described in Section 4.2.4 of this Technical Support Document to estimate TWPE. Table 6-8 lists the estimated pounds and TWPE for each SIC code.

Table 6-8. OCPSF Pollutant Load Discharged to Surface Water in 2000 by SIC Code¹

SIC Code	SIC Code Name	TRI		PCS	
		Pounds	TWPE	Pounds	TWPE
2821	Plastic Materials, Synthetic Resins, and Nonvulcanizable Elastomers	5,000,000	112,000	252,000,000	489,000
2823	Cellulosic Man-Made Fibers	438,000	29,200	499,000,000	60,700
2824	Synthetic Organic Fibers, Except Cellulosic	1,740,000	2,420	13,100,000	3,290
2865	Cyclic Crudes and Intermediates, Dyes, and Organic Pigments	2,470,000	950,000	54,100,000	324,000
2869	Industrial Organic Chemicals, Not Elsewhere Classified	44,400,000	6,110,000	1,590,000,000	1,280,000
Total Reported TWPE for OCPSF Category		54,000,000	7,200,000	2,410,000,000	2,110,000

Sources: *PCSLoads2000* and *TRIReleases2000*.

Notes: Numbers updated from SIC code totals from the proposed Notice, 12/31/03, because of data corrections described in Section 2.0 of this section.

¹The pollutant load discharged to surface water was estimated by *TRI Releases 2000* using pollutant releases directly to surface water and transfers to publicly-owned treatment works (POTWs), taking POTW removals into account.

EPA also used PCS data to determine the volume of wastewater discharge (which is not reported in TRI); however, the total flow rates reported to PCS may include stormwater and noncontact cooling water, as well as process wastewater. In some cases, the PCS database identifies the type of wastewater being discharged; however, most reported flow rates do not indicate the type of wastewater. Table 6-9 lists the flows reported for each SIC code.

Table 6-9. OCPSF Annual Wastewater Flows by SIC Code as Reported to PCS in 2000

SIC Code	SIC Code Name	Number of Facilities ¹	Range of Facility Flows, MGY (MGD)	Median Facility Flow, MGY (MGD)	Average Facility Flow, MGY (MGD)	Total for SIC code, MGY
2821	Plastic Materials, Synthetic Resins, and Nonvulcanizable Elastomers	91	0.648 to 168,489 (0.002 to 462)	619 (1.69)	4,961 (13.6)	451,444
2823	Cellulosic Man-Made Fibers	4	0.0000108 to 9,926 (<0.001 to 27.2)	4,692 (12.9)	4,828 (13.2)	19,310
2824	Synthetic Organic Fibers, Except Cellulosic	5	32.4 to 60,020 (0.09 to 164)	543 (1.49)	12,352 (33.8)	61,762
2865	Cyclic Crudes and Intermediates, Dyes, and Organic Pigments	22	14.1 to 33,176 (0.039 to 90.9)	360 (0.987)	3,570 (9.78)	78,534

Table 6-9 (Continued)

SIC Code	SIC Code Name	Number of Facilities ¹	Range of Facility Flows, MGY (MGD)	Median Facility Flow, MGY (MGD)	Average Facility Flow, MGY (MGD)	Total for SIC code, MGY
2869	Industrial Organic Chemicals, Not Elsewhere Classified	113	1.20 to 367,185 (0.003 to 1,006)	1202 (3.29)	12,378 (33.9)	1,398,663

Notes:

Source: *PCS Loads 2000*.

MGY - Million gallons per year.

¹ Number of Major Facilities Reporting Nonzero Flows.

The median per facility flows range from 0.987 MGD for facilities in SIC code 2865 to 12.9 MGD for facilities in SIC code 2823. These flows are somewhat higher than the average flow for direct dischargers reported in the 1987 TDD (1.31 MGD). This suggests either that facilities have greater water use than in 1987 (perhaps concurrent with greater production) or that flows reported to PCS include nonprocess wastewaters such as noncontact cooling water and stormwater runoff.

6.3.3.2 General Wastewater Treatment

EPA collected on-site wastewater treatment data from the 2000 TRI. Table 6-10 summarizes this information.

Table 6-10. Wastewater Treatment Operations Reported by OCPSF Facilities TRI Reporting Year 2000

Wastewater Treatment Process	Number of Facilities Reporting Use	
	Direct ¹ (213 facilities)	Indirect ¹ (176 facilities)
Biological Treatment	207	60
Settling/Clarification	136	59
Equalization	120	65
Neutralization	101	90
Filtration	75	34
Stripping (air and steam)	50	54
Chemical precipitation	42	31
Adsorption	32	33

Source: *TRIRelases2000*.

¹Of the facilities that provided information on their wastewater treatment operations in TRI 2000, 213 facilities reported direct releases, 176 facilities reported transfers to POTWs, and 20 facilities reported both direct releases and transfers to POTWs.

6.3.4 Focus Industry Identification and SIC Code Analysis

For the screening-level analysis, EPA examined the pollutant discharges reported to TRI and PCS for the five SIC codes in the OCPSF category (see Table 6-8). After the screening analysis, EPA focused the detailed review of the OCPSF category on the most toxic pollutant discharges as measured by TWPE. Section 6.3.4.1 discusses how EPA identified three focus industries with the most toxic pollutant discharges. Section 6.3.4.2 discusses how EPA identified two SIC codes that would not be further investigated at this time: 2823 and 2824 (the fiber manufacturers).

6.3.4.1 Focus Industry Identification

Using 2000 TRI and PCS data, EPA determined which pollutants were discharged with the greatest TWPE for the OCPSF category. Table 6-11 shows the most toxic pollutants, by TWPE, for the OCPSF category:

Table 6-11. Top Pollutants Reported Discharged in 2000 for the OCPSF Category

Pollutant Reported	Data Source	Pounds Reported	TWPE Reported
Dioxin and dioxin-like compounds	TRI	3.27 (1,480 grams)	5,700,000
Polycyclic aromatic compounds	TRI	2,020	941,000
Aniline	TRI	85,600	120,400

Source: *TRI Releases 2000*.

EPA examined the highest pollutant discharges at the SIC code level and determined that:

- In SIC code 2865, the facilities that reported PACs to TRI all perform coal tar refining;
- In SIC code 2865, the facilities that reported aniline to TRI either manufacture aniline or produce dyes; and
- In SIC codes 2821 and 2869, the facilities that reported releases of dioxin and dioxin-like compounds are mainly manufacturers of EDC/VCM/PVC, with some also having co-located chlor-alkali plants.

EPA reviewed in more detail these three groups of facilities, referred to as OCPSF focus industries: coal tar refiners, aniline dischargers, and dioxin dischargers. Sections 6.6, 6.7, and 6.8 of this section discuss the focus industries in greater detail.

6.3.4.2 No Further Consideration of SIC Codes 2823 and 2824: Fiber Manufacturers

In reviewing the reported pollutant dischargers for 2000, EPA noted that the fiber manufacturing process does not discharge as many toxic pounds of chemicals as other OCPSF manufacturing processes (17). Based on 2000 TRI and PCS data, facilities in SIC codes 2823 (Cellulosic Man-Made Fibers) and 2824 (Synthetic Organic Fibers, Except Cellulosic) contribute less than 3 percent of the TWPE reported discharged by the OCPSF category. Both fiber manufacturing SIC codes (2823 and 2824) have fewer facilities in the 1997 U.S. Census and fewer pounds and toxic pounds of pollutants reported to TRI and PCS, compared with other OCPSF SIC codes.

Synthetic Fiber Production

Facilities in SIC codes 2823 and 2824 manufacture cellulosic and other man-made fibers, as opposed to naturally occurring fibers such as cotton, wood, or silk. Synthetic fibers produced using cellulose (wood- or other plant-based) feedstock fall in SIC code 2823; those produced from petroleum or other chemical feedstocks fall in SIC code 2824. Synthetic cellulosic fibers include rayon (including Tencel® and Lyocell) and acetate. Synthetic noncellulosic fibers include (26):

- Nylon;
- Modacrylic;
- Olefin;
- Acrylic;
- Acrylonitrile rubber;
- Polyester;
- Vinyon;
- Saran;
- Spandex;
- Aramid;
- Polybenzimidazole (PBI); and
- Sulfar.

The manufacturing process for fiber production varies per type of fiber. Manufacturing of cellulosic fibers such as rayon begins with production of viscose, a syrupy liquid made from cellulose in sodium hydroxide solution. The viscose is passed through fine holes to become threads, collected in a dilute acidic medium, such as sulfuric acid. For nylon manufacturing, a petroleum-based synthetic fiber, adipic acid is reacted with hexamethylene diamine to form an amide structure polymer. The resulting polyamide is forced through fine holes, forming threads of nylon (Tools for Teaching).

Facilities in SIC Codes 2823 and 2824

Table 6-12 lists all facilities that reported SIC codes 2823 or 2824 as their primary SIC codes in the 2000 TRI and/or PCS 2000.

Table 6-12. Facilities in SIC Codes 2823 and 2824 in the 2000 TRI and/or PCS 2000

Facility Name	Location
SIC Code 2823: Cellulosic Man-Made Fibers	
Acordis Cellulosic Fibers Inc.	Axis, AL
BASF Enka	Enka, NC
Celanese Acetate Celriver Plant	Rock Hill, SC
Eastman Chemical Co. Tennessee Operations	Kingsport, TN
North American Fibers Corporation	Elizabethton, TN
Lenzing Fibers Corporation	Lowland, TN
SIC Code 2824: Synthetic Organic Fibers, Except Cellulosic	
Solutia Inc.	Decatur, AL
Hexcel Corporation	Decatur, AL
Solutia Inc.	Cantonment, FL
Sterling Fibers, Inc.	Pace, FL
Globe Manufacturing Corporation	Fall River, MA
Honeywell International Inc.	Moncure, NC
DuPont Fibers Kinston	Kinston, NC
Arteva Specialties/KOSA	Salisbury, NC
Globe Manufacturing Corporation	Gastonia, NC
BASF Corporation Clemson Site	Central, SC
DuPont Camden-May Plant	Camden, SC
Arteva Specialties/KOSA	Spartanburg, SC
Wellman Inc./Palmetto Plant	Darlington, SC
BASF Corporation Fiber Products Division	Anderson, SC
Du Pont Chattanooga Plant	Chattanooga, TN
Polyloom Corporation Of America	Dayton, TN
Hexcel Corporation	Salt Lake City, UT
Du Pont Spruance Plant	Richmond, VA
Honeywell International Inc.	Hopewell, VA

Sources: *PCSLoads2000* and *TRIRelases2000*.

Table 6-13 lists the four facilities that reported their primary SIC code as 2821 (Plastic Materials, Synthetic Resins, and Nonvulcanizable Elastomers) in TRI but are classified as SIC code 2824 (Synthetic Organic Fibers, Except Cellulosic) in PCS.

Table 6-13. Facilities with Primary SIC Code 2824 in PCS and 2821 in TRI

Facility Name	Location	Primary SIC Code	
		TRI	PCS
DuPont Fibers Kinston	Kinston, NC	2821	2824
DuPont Camden-May Plant	Camden, SC	2821	2824
Sterling Fibers, Inc.	Pace, FL	2821	2824
Wellman Inc./Palmetto Plant	Darlington, SC	2821	2824

Sources: *PCSLoads2000* and *TRIRelases2000*.

Table 6-14 lists the five facilities classified as SIC codes 2821 (Plastic Materials, Synthetic Resins, and Nonvulcanizable Elastomers), 2869 (Other Organic Chemicals, NEC), 2281 (Yarn Spinning Mills) or 5169 (Chemical Wholesale Distributors) in PCS but that reported their primary SIC code as 2824 to TRI.

Table 6-14. Facilities with Primary SIC Code 2824 in TRI and Other in PCS

Facility Name	Location	Primary SIC Code	
		TRI	PCS
Arteva Specialties S.A.R.L. (dba Kosa Spartanburg)	Spartanburg, SC	2824	2821
BASF Corporation Fiber Producers	Anderson, SC	2824	2281
BASF Corporation, Clemson Site	Central, SC	2824	2821
Honeywell International, Inc.	Moncure, SC	2824	5169
Solutia	Cantonment, FL	2824	2869

Sources: *PCSLoads2000* and *TRIRelases2000*.

For the screening-level review, EPA included discharge loads as they were reported. For example, the DuPont Kinston plant TRI-reported releases were included in the totals for SIC code 2821, while the PCS-reported discharges were included in SIC code 2824. For more information on how SIC code totals were calculated, see Section 4.2.4 in this Technical Support Document.

Some facilities that reported to TRI are not in PCS Loads 2000, because they are either indirect dischargers or minor direct dischargers.

Pollutants of Concern for SIC Codes 2823 and 2824

The 1987 TDD sampling data show that effluent from synthetic fiber manufacturers contained the following priority pollutants at significant concentrations: acrylonitrile, isophorone, phenol, and other aromatics. The sampling data showed that effluent from other OCPSF operations, such as plastics and commodity, bulk, and specialty organic chemicals manufacturing, contained greater numbers of priority pollutants at significant

concentrations compared to synthetic fiber manufacturers. The 1987 TDD also shows that wastewater effluent from synthetic fiber manufacturers contained pollutants in lower concentrations compared to wastewater from other OCPSF manufacturing processes.

Table 6-15 lists the pollutants with the highest TWPE for both synthetic fiber SIC codes based on 2000 TRI data. For both SIC codes, the discharges of each pollutant (except carbon disulfide) are from only one facility, and one facility accounts for the majority of the discharged TWPE:

- SIC code 2823
 - Eastman Chemical, Kingsport, TN accounts for 76 percent of the TRI TWPE, and
 - Acordis Fibers, Axis, AL accounts for 94 percent of the PCS TWPE.
- SIC code 2824
 - Solutia, Cantonment, FL accounts for 57 percent of the TRI TWPE, and
 - Solutia, Decatur, AL accounts for 93 percent of the PCS TWPE.

Table 6-15. Pollutants with Highest TWPE Based on 2000 TRI Data

Pollutants With Highest TWPE	Pounds/Year	TWPE/Year	Percentage of Total TWPE for SIC Code	Number of Facilities Reporting Pollutant
SIC Code 2823: Cellulosic Man-Made Fibers				
Lead compounds	2,400	5,376	18%	1
Aniline	3,600	5,061	17%	1
Arsenic compounds	810	2,810	10%	1
Carbon disulfide	1,730	4,844	16%	2
Quinone	1,400	1,742	6%	1
Manganese compounds	18,000	1,268	4%	1
SIC Code 2824: Synthetic Organic Fibers, Except Cellulosic				
Copper	1,403	880	36%	1
Cadmium	260	679	28%	1
Vanadium compounds	795	495	20%	1
Ammonia	79,000	119	5%	1
Nitrate compounds	1,500,000	93	4%	1

Source: *TRIRelases2000*.

Table 6-16 lists the pollutants with the highest TWPE for both SIC codes based on PCS data.

Table 6-16. Pollutants with Highest TWPE Based on PCS 2000 Data

Pollutants With Highest TWPE	Pounds/Year	TWPE/Year	Percentage of Total TWPE for SIC Code	Number of Facilities Reporting Pollutant
SIC Code 2823: Cellulosic Man-Made Fibers				
Carbon disulfide	19,250	53,900	89%	1
Total zinc	41,225	1,927	3%	1
SIC Code 2824: Synthetic Organic Fibers, Except Cellulosic				
Total manganese	13,151	926	28%	1
Total recoverable iron	151,124	846	26%	1
Ammonia as nitrogen	306,443	561	17%	1
Total cyanide	430	463	14%	1
Total iron	37,489	210	6%	1

Source: PCSLoads2000.

From the data presented in Tables 6-15 and 6-16, EPA was unable to identify a pollutant of concern discharged by a significant number of facilities, at high volume, or with high TWPE relative to the rest of the OCPSF category.

6.3.4.3 Decision for No Further Investigation

SIC codes 2823 (Cellulosic Man-Made Fibers) and 2824 (Synthetic Organic Fibers, Except Cellulosic) represent a relatively small part of the OCPSF category, by number of facilities, pounds of pollutant discharged, and TWPE discharged. Furthermore, a single facility in each SIC code drives the estimate of the total TWPE discharged for all facilities in each SIC code. Therefore, EPA did not further analyze these SIC codes for this review. Rather, EPA may offer permit support for the few facilities driving the TWPE estimates.

6.4 Current Effluent Limitations Guidelines and Standards

Effluent limitations guidelines and pretreatment standards for the OCPSF category, codified at 40 CFR Part 414, were promulgated in 1987 and amended in 1992. Table 6-17 summarizes the existing regulations.

Table 6-17. Summary of Existing Effluent Limitations Guidelines and Pretreatment Standards (40 CFR Part 414)

Pollutants Controlled			
BPT, NSPS	BCT	BAT, NSPS	PSES, PSNS
BOD ₅ TSS pH (For all subcategories)	Reserved	List of 62 priority pollutants (for Subcategory I) List of 58 priority pollutants (for Subcategory J)	List of 45 priority pollutants (for Subcategory K)
Implementation			
Limitations are concentration-based. Each plant's limits are derived from formulae that prorate limitations based on production in each subpart. BAT is applicable only to operations producing >5 million pounds of OCPSF products per year.			
Subcategories			
B. Rayon Fibers C. Other Fibers D. Thermoplastic Resins E. Thermosetting Resins F. Commodity Organic Chemicals G. Bulk Organic Chemicals H. Specialty Organic Chemicals		I. Direct Discharge Point Sources That Use End-of-Pipe Biological Treatment J. Direct Discharge Point Sources That Do Not Use End-of-Pipe Biological Treatment K. Indirect Discharge Point Sources	

See 40 CFR Part 414, Subparts I, J, and K for the BAT chemical-specific limitations.

The technology basis for the BPT limitations (conventional pollutants only) is biological treatment with clarification, preceded by appropriate in-plant process controls and treatment.

EPA promulgated Best Available Technology Economically Available (BAT) limitations for two subcategories: facilities with biological treatment and facilities without biological treatment. For BAT Subcategory I, the wastewater treatment technology basis was end-of-pipe biological treatment with in-plant controls such as steam stripping (for volatile and semi-volatile pollutants), activated carbon (for certain base/neutral priority pollutants), hydroxide precipitation (for metals), and alkaline chlorination for cyanide. For BAT Subcategory J, the wastewater treatment technology was physical/chemical end-of-pipe treatment, with the same in-plant controls listed for Subcategory I.

The technology basis for the Pretreatment Standards for Existing Sources (PSES) and Pretreatment Standards for New Sources (PSNS) limitations is the same as the technology basis for BAT Subcategory J: facilities without biological treatment. New Source Performance Standards (NSPS) limitations are based on BAT Subcategory I: facilities with biological treatment.

6.5 Other Regulations Affecting OCPSF Facilities

EPA's sector notebook, *Profile of the Organic Chemical Industry 2nd Edition, 2002* (22) lists regulations affecting OCPSF facilities. The OCPSF category is regulated by nearly all federal environmental statutes, as well as state and local regulations (not listed here).

6.5.1 **Resource Conservation and Recovery Act (RCRA)**

Over 50 materials generated in OCPSF manufacturing processes are listed hazardous waste from specific sources (K wastes). Additional OCPSF wastes are nonspecific hazardous wastes (F wastes) or hazardous waste by characteristic (D wastes). Some OCPSF wastes are banned from land disposal (land disposal restrictions are set forth at 40 CFR Part 268). RCRA regulates hazardous waste generation, transport, storage, and disposal at 40 CFR Part 262.

Depending on the quantity and type of hazardous waste generated, facilities are classified as either small or large quantity generators. If facilities store hazardous wastes beyond set RCRA accumulation time limits (e.g., 90 or 180 days), RCRA regulates them as treatment, storage, and disposal facilities (TSDFs). TSDFs have additional permit requirements (40 CFR Part 262.34).

The remainder of this section discusses the listed hazardous waste pertaining to the focus industries. For the dioxin-discharging focus industry, the following are listed hazardous waste:

- K019 - Heavy ends from EDC distillation columns;
- K020 - Heavy ends from VCM distillation columns;
- K071 - Brine purification muds from chlor-alkali plants (listed for mercury constituent);
- K073 - Chlorinated hydrocarbon waste from diaphragm cell purification (listed for chlorinated hydrocarbon constituents);
- K106 - Mercury cell wastewater treatment sludge (listed for mercury constituent);
- K174 - Wastewater treatment sludge from EDC, EDC/VCM, or VCM processes (listed for dioxins and furans constituents); and
- K175 - Wastewater treatment sludge from VCM produced from acetylene gas (listed for mercury constituent).

In 1999, EPA proposed listing K173 (wastewater from the EDC, EDC/VCM, and VCM wastewater processes). For the final RCRA Chlorinated Aliphatics Rule promulgated in 2000, however, EPA ultimately decided that the risk from K173 waste was not high enough to require listing it as hazardous waste.

For coal tar refiners, the following wastes are listed hazardous waste:

- K147 – Tar storage tank residues from coal tar refining; and
- K148 – Residues from coal tar distillation, including but not limited to, still bottoms.

For aniline dischargers, the following wastes are listed hazardous waste:

- K083 – Distillation bottoms from aniline production;
- K103 – Process residues from aniline extraction from the production of aniline; and
- K104 – Combined wastewater streams generated from nitrobenzene/aniline production.

6.5.2 Comprehensive Environmental Response, Compensation, and Liability Act (CERCLA)

Part of CERCLA regulates underground storage tanks (USTs), which may be in place at OCPSF facilities. The UST regulations apply to facilities with either petroleum products or hazardous substances (but not hazardous waste) identified under CERCLA. The UST regulations require tanks made of certain materials, record keeping, and monitoring.

6.5.3 Clean Air Act (CAA)

The CAA regulates air emissions from both unit operations at OCPSF and supporting equipment (e.g., boilers, storage tanks) under New Source Performance Standards (NSPS), the National Emissions Standards for Hazardous Air Pollutants (NESHAPs), and the State Implementation Plans (SIP). Also, new or modified sources that are considered "major" under the CAA are subject to new source review (NSR).

For OCPSF operations, the following emission points may be regulated, depending on the characteristics of each unit operation and the applicability requirements of each rule:

- Process vents;

- Volatile organic liquid storage vessels (regulates applicable storage tanks containing volatile organic liquids, including petroleum liquid storage vessels);
- Equipment leaks (vapor leaks from pumps, valves, connectors, etc.);
- Transfer operations;
- Heat exchangers;
- Wastewater processes; and
- Benzene waste operations.

The following sections discuss the air regulations that apply to OCPSF facilities: NESHAPs program, NSPS, Consolidated Air Rule, State Implementation Plans, New Source Review, and Title VI Stratospheric Ozone Protection.

6.5.3.1 NESHAPs Program

The NESHAPs program sets standards to control toxic air releases. HON is one of many NESHAPs but is the predominant rule that will affect most facilities in the synthetic organic chemical manufacturing industry (SOCMI). HON regulations (40 CFR Part 63 Subparts F, G, H, and I) cover emissions of hazardous air pollutants from process vents, transfer operations, storage vessels, wastewater, and equipment leaks at certain high-volume chemical processes. Like all NESHAPs, the HON applies to "major sources," which are defined as facilities that emit or have the potential to emit 10 tons per year or more of any hazardous air pollutant (HAP) or 25 tons per year or more of any combination of HAPs.

The Miscellaneous Organic NESHAP (MON) regulates OCPSF unit operations that are not regulated by the HON: batch processes and small volume organic chemicals. Also, there are NESHAPs that apply to polymer and resin manufacturing, cooling towers, and boilers/process heaters (The final rule for boilers/heaters has been signed but had not appeared in the Federal Register as of August 2004).

The HON, MON, polymer, and boiler NESHAPs are all technology-based air standards, and typically are referred to as Maximum Achievable Control Technology (MACT) standards. These are all codified at 40 CFR Part 63. Other NESHAPs that cover emissions from OCPSF facilities are based on preventing risks to public health. The risk-based NESHAPs that apply to OCPSF facilities are:

- Vinyl chloride manufacturers (40 CFR Part 61 subpart F);
- Benzene equipment leaks (40 CFR Part 61 subpart J);
- Equipment leaks (fugitive emission sources) (40 CFR Part 61 subpart V);
- Benzene storage vessels (40 CFR Part 61 subpart Y);

- Benzene transfer operations (40 CFR Part 61 subpart BB); and
- Benzene waste operations (40 CFR Part 61 subpart FF).

6.5.3.2 NSPS

The NSPS program sets emission standards for new, modified, or reconstructed sources of criteria pollutants. The standards reflect the degree of emission reduction achievable through application of best demonstrated control technology, considering the cost and any nonair health and environmental impacts and energy requirements. For OCPSF, the NSPS regulate volatile organic compound emissions from process vents, storage tanks, and equipment leaks at synthetic organic chemical and polymer manufacturing plants. The NSPS also regulate NO_x, SO₂, and PM emissions from boilers.

6.5.3.3 Consolidated Air Rule (CAR)

The CAR is an optional rule aimed to reduce the burden and potential confusion of complying with multiple air regulations for the same process equipment. The purpose of the CAR, codified at 40 CFR Part 65, is to consolidate overlapping regulatory requirements of the SOCOMI NSPS, HON, and the Part 61 risk-based NESHAP into a single set of regulatory requirements that will satisfy all these rules, while achieving equivalent or better emission reduction. Facilities can choose to comply with the CAR in lieu of the following rules:

- 40 CFR Part 60, subparts A, Ka, Kb, VV, DDD, III, NNN, and RRR;
- 40 CFR Part 61, subparts A, V, Y, and BB; and
- 40 CFR Part 63, subparts A, F, G, and H.

6.5.3.4 State Implementation Plans (SIP)

An OCPSF facility also may be required to comply with SIP regulations. The SIP regulations contain emission standards adopted by each state to ensure compliance with National Ambient Air Quality Standards (NAAQS). NAAQS has been established for sulfur dioxide, nitrogen dioxide, particulate matter, carbon monoxide, lead, and ozone (SIPs regulate volatile organic compounds and nitrogen oxides to control ozone).

6.5.3.5 New Source Review

New source review is a preconstruction permit program that is designed to ensure that industrial growth does not cause new air pollution problems. New or modified major sources that are located in areas that comply with the NAAQS must obtain a Prevention of Significant Deterioration (PSD) permit. Sources in nonattainment areas must obtain a more stringent Nonattainment NSR permit. Among other requirements, these permits require installation of state-of-the-art emission controls, which are determined on a case-by-case basis by the permitting authority.

6.5.3.6 Title VI Stratospheric Ozone Protection

Many organic chemical facilities operate industrial process refrigeration units, such as chillers for chlorine dioxide plants. For those units that utilize ozone-depleting chemicals, such as chlorofluorocarbons (CFCs), facilities are required under Title VI to follow leak repair requirements.

6.5.4 **Toxic Substances Control Act (TSCA)**

Under TSCA, EPA collects data on chemicals to evaluate, assess, mitigate, and control risks that may be posed by their manufacture, processing, and use. Pesticides, defined in the Federal Insecticide, Fungicide, and Rodenticide Act (FIFRA), are not included in the definition of a "chemical substance" when manufactured, processed, or sold for use as a pesticide. TSCA affects many OCPSF chemicals, including new chemicals currently under development.

The following list includes some of the TSCA regulations that affect OCPSF facilities:

- Section 4: High Production Volume Rule. One example is EPA's analysis of the use and manufacture of polybrominated diphenyl ether compounds (40 CFR Parts 766, 790-799);
- Section 5: Premanufacture Notices (40 CFR Parts 700, 720-725, 747);
- Section 6: Regulates or bans the chemical uses that present unreasonable risks, such as asbestos, chlorofluorocarbons (CFCs), lead, and PCBs (40 CFR Parts 747, 749, 761, and 763);
- Section 8: Inventory Update Rule (IUR) (40 CFR Parts 710-717);
- Section 8(a): The Preliminary Assessment Information Rule (PAIR), which requires facility information on manufacturing or importing any chemicals listed in 40 CFR Part 712.30 for commercial purposes;
- Section 8(c): Allegations of Significant Adverse Reactions Rule;
- Section 8(d): Unpublished Health and Safety Studies Rule;
- Section 8(e): Substantial Risk Information Requirement;
- Section 12: TSCA chemical exporter requirements; and
- Section 13: Chemical importer requirements (40 CFR Part 707 and 19 CFR Parts 12.118-12.128).

6.5.5 Emergency Planning and Community Right-To-Know Act (EPCRA)

EPCRA includes TRI reporting (Section 313), emergency planning (Section 304), and emergency notification of extremely hazardous substance release (Section 302(a)). Most OCPSF facilities are required to report to TRI annually (see also Section 4.2.1 of this Technical Support Document). Under Section 302(a), OCPSF facilities that produce, use, or store “hazardous substances” must report information to the state. Under Section 304, OCPSF facilities that unintentionally spill or release a reportable quantity of an extremely hazardous substance must report that release to the state emergency planning commission and the local emergency planning commission.

6.5.6 Pending and Proposed Regulatory Requirements

Additional regulations affecting facilities in the OCPSF category are not yet finalized. The NSPS for SOCOMI wastewater is proposed to control air emissions of VOCs from wastewater treatment operations. Under RCRA, EPA may create a Standardized Permit for RCRA Hazardous Waste Management Facilities for facilities that generate waste and routinely manage the waste at their site in tanks, containers, and containment buildings. The goal of the standardized permit is to streamline the permit process.

6.6 Focus Group 1: Coal Tar Refiners

Coal tar refiners distill tar from by-product cokemaking operations. The end products from coal tar refining include industrial pitches and other by-product chemicals. This section discusses EPA’s findings on the coal tar refining industry in the following subsections:

- Section 6.6.1 presents the facilities identified as coal tar refiners;
- Section 6.6.2 describes the process of coal tar refining and the sources and type of wastewater generated by coal tar refiners;
- Section 6.6.3 lists the pollutants of concern identified based on available data;
- Section 6.6.4 lists the wastewater treatment in place based on available data;
- Section 6.6.5 describes industry trends; and
- Section 6.6.6 presents EPA’s conclusions.

6.6.1 Facilities

EPA identified three U.S. coal tar refining companies (10 facilities) operating in 2000. Table 6-18 lists these facilities.

Table 6-18. Coal Tar Refiners in the United States

Company	Location	Facility Operations/Status	Discharge Status
<i>Honeywell Inc.</i>	<i>Birmingham, AL</i>	<i>Coal tar refiner. Facility closed June 2003.</i>	<i>Direct/Major</i>
	<i>Ironton, OH</i>	<i>Coal tar refiner. Facility closed 2002.</i>	<i>Direct/Major</i>
	<i>Detroit, MI</i>	<i>Coal tar refiner. Facility closed January 2004.</i>	<i>Indirect/Minor</i>
Koppers Industries Inc.	Clairton, PA	Coal tar refiner, producing creosote, naphthalene, and industrial pitches. Primary SIC code in TRI is 2865.	Direct/Minor
	Follansbee, WV	Coal tar refiner, producing creosote, naphthalene, and industrial pitches. Primary SIC code in TRI is 2865.	Direct/Major
	Cicero, IL	Location also known as Stickney. Coal tar refiner, producing creosote, naphthalene, and industrial pitches. Primary SIC code in TRI is 2865.	Indirect
	Dolomite, AL	Location also known as Woodward Plant. Coal tar refiner, producing roofing pitch and tar sealer.	Direct/Major
Reilly Tar & Chemical Co.	Granite City, IL	Coal tar refiner.	Indirect
	<i>Cleveland, OH</i>	<i>Coal tar refiner. Facility closed (date believed to be 2000).</i>	<i>Indirect</i>
	Lone Star, TX	Coal tar refiner.	Indirect

Sources: *PCSLoads2000* and *TRIRelapses2000*, American Coke and Coal Chemicals Company web page, and company web pages.

Italics denote facilities no longer in operation.

Since 2000, Honeywell, Inc. closed all three of its coal tar refining operations, and Reilly Tar & Chemical Company closed one of its locations. As of the date of this report, six facilities owned by two companies continue to refine coal tar in the United States.

6.6.2 Process Description and Wastewater Sources

Coal tar refiners process tar from by-product cokemaking through a distillation column. The tar is formed as a by-product during coking, which is producing metallurgical coke from baking coal at high temperatures. The primary product of coking is coke, but heating of the coal also forms coke oven gas, light oil, coal tar, and other by-products.

Coal tar refiners pass the coal tar through a still, and recover the bottoms as industrial pitches. Applications for coal tar pitches include the following:

- Binder for petroleum coke to make pre-baked anodes for primary aluminum manufacturers;
- Tar-based road binders;
- Roofing;

- Damp-proofing (e.g., for waterproofing basement walls);
- Waterproofing; and
- Hot-applied tar-based coatings (pipeline enamels).

In addition, coal tar refiners may recover naphthalene, creosote, and other chemicals from higher up in the still or after further processing. Figure 6-1 shows a simplified process flow diagram for coal tar refining (4).

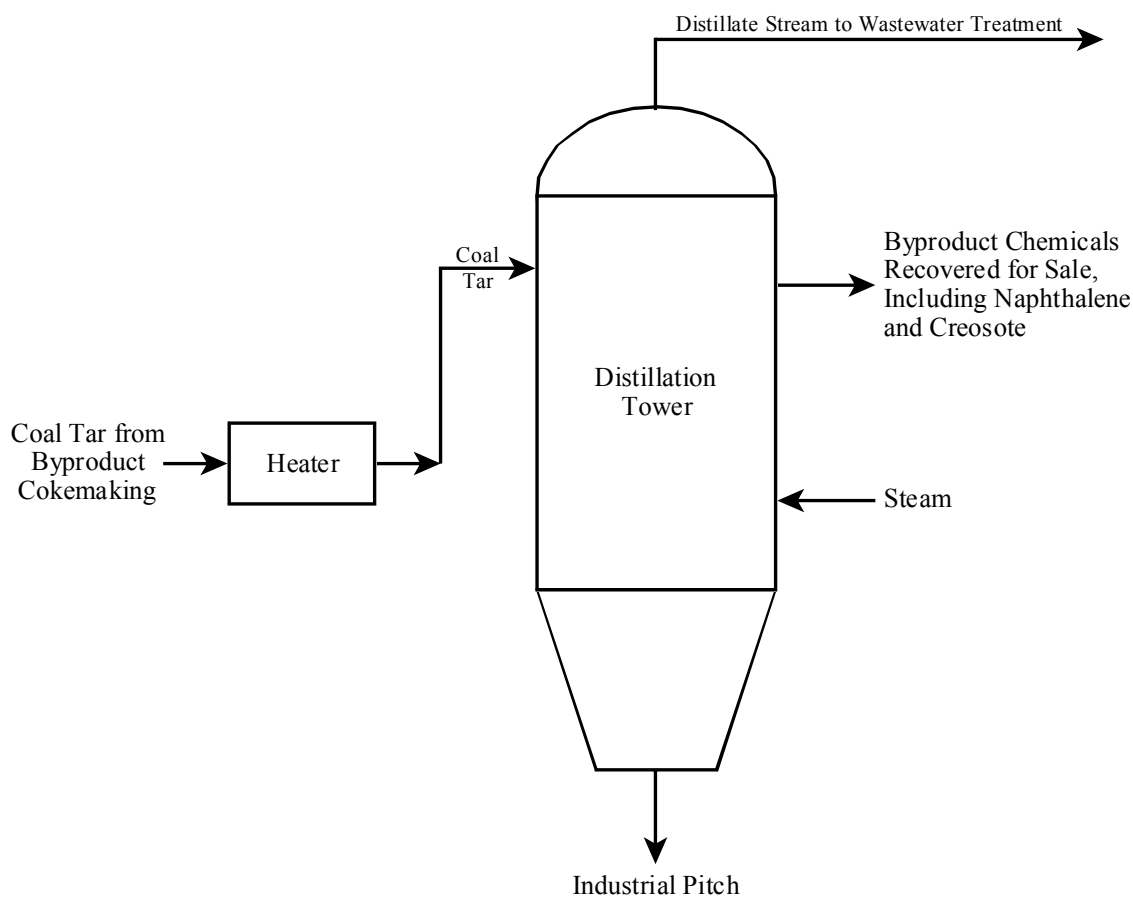

Figure 6-1. Coal Tar Refining Process Flow Diagram

Wastewater is generated from the distillate stream, which is passed through a decanter. Light oil is decanted in this step, and the liquor, or decant bottoms, are sent to wastewater treatment. The following coal tar residues (e.g., sludges) are listed hazardous waste:

- K148: Residues from coal tar distillation, including but not limited to, still bottoms; and

- K147: Tar storage tank residues from coal tar refining.

The coal tar residues are K-listed because they fail the toxicity characteristic for benzo(a)anthracene, benzo(a)pyrene, benzo(b)fluoranthene, benzo(k)fluoranthene, dibenzo(a,h)anthracene, and indeno(1,2,3-cd)pyrene (40 CFR Part 261), all of which are included in the TRI PACs chemical category.

6.6.3 Pollutants of Concern

EPA used TRI and PCS data to determine the pollutants of concern for the OCPSF Focus Group 1 facilities: coal tar refiners.

6.6.3.1 TRI Data

Five of the 10 facilities listed in Table 6-18 reported PACs releases to wastewater or transfers to POTWs in 2000 and/or 2001. (See Section 4.2.4.3 for a list of the 21 individual PACs compounds). Of the other five facilities, four did not report wastewater PACs releases but reported releases of other chemicals. The remaining facility, Reilly Tar & Chemical Company in Cleveland, shut down, and no TRI data are available for that facility after 1999. PACs account for more than 99.9 percent of the TWPE of wastewater releases reported to TRI by these facilities. Table 6-19 shows the PACs releases reported to TRI in 2000 and 2001, taking POTW removals into account, and the corresponding TWPE calculated by EPA. As explained in Section 6.2.1, EPA used the TWF for benzo(a)pyrene to calculate TWPEs for the TRI PAC category. Because coal tar residues also contain other individual PAC constituents and because benzo(a)pyrene is the most toxic individual PAC constituent, this results in an overestimate.

Table 6-19. PACs Water Discharges Reported to TRI for 2000 and 2001

Company	Location	2000 Discharges		2001 Discharges		Percent Change from 2000
		Pounds	TWPE	Pounds	TWPE	
Koppers Industries Inc. Woodward Plant	Dolomite, AL	63	269,864	16	68,537	-75%
Koppers Industries Inc.	Follansbee, WV	0	0	5	21,418	NA
Honeywell Inc.	Birmingham, AL	6	25,701	6	25,701	0%
Honeywell Inc.	Ironton, OH	120	514,027	102	436,923	-15%
Reilly Tar & Chemical Co.	Granite City, IL	0.59 ¹	2,522	0.77 ¹	3,298	31%

Source: *TRIRelases2000*.

NA - Not applicable. Koppers in Follansbee reported discharging zero pounds of PACs in 2000.

¹The pounds of PACs discharged for Reilly Industries reflects POTW treatment. EPA estimated that the POTW removed 93 percent of the PACs generated at the facility.

6.6.3.2 PCS Data

PCS data were available for four coal tar refining facilities; the other facilities are either indirect dischargers (five) or minor dischargers (one). Generally, NPDES permits require facilities to monitor for individual pollutants, rather than the group of pollutants, PACs, as reported to TRI. Of the four facilities with PCS data, three reported discharging any of the individual PACs at detectable levels for 2000. The fourth facility, Honeywell's Birmingham facility, did not detect any individual PACs in their wastewater in 2000. Table 6-20 shows the PCS PACs discharge data for 2000. Each of the three facilities listed in Table 6-20 reported more pounds of PACs to TRI than of individual PACs in their monitored discharges, suggesting that the PACs reported to TRI may be over-estimated.

Table 6-20. PACs Wastewater Discharges Reported to PCS in 2000

Company	Location	Chemical	2000 Discharges	
			Pounds	TWPE
Koppers Industries Inc.	Follansbee, WV	Benzo(a)pyrene	2.1	9,148
		Benzo(b)fluoranthene	2.0	854
		Benzo(a)anthracene	0.83	151
		Benzo(k)fluoranthene	1.0	42
		Chrysene	1.3	2.7
		Fluoranthene	1.3	1.0
		Pyrene	1.4	0.15
Koppers Industries. Inc. Woodward Tar Plant	Dolomite, AL	Benzo(a)pyrene	0	0
		Chrysene	0	0
		Fluoranthene	0	0
		Benzo(a)anthracene	0	0
		Benzo(k)fluoranthene	0.26	11
Honeywell Inc.	Ironton, OH	Benzo(b)fluoranthene	0	0
		Benzo(k)fluoranthene	0	0
		Benzo(a)pyrene	0	0
		Chrysene	0	0
		Indeno(1,2,3-cd)pyrene	0	0
		Benzo(a)anthracene	0	0
		Dibenzo(a,h)anthracene	0	0
		Fluoranthene	2.6	2.1
Honeywell Inc.	Birmingham, AL	Benzo(k)fluoranthene	0	0
		Benzo(a)pyrene	0	0
		Chrysene	0	0
		Fluoranthene	0	0
		Benzo(a)anthracene	0	0

Source: PCSLoads2000.

Table 6-21 presents the range and median concentrations of PACs reported to PCS in 2000. These pollutants were discharged at concentrations below the minimum level – generally an order of magnitude lower. The concentration of PACs in OCPSF Focus Group 1 wastewaters is at or near BAT concentrations. EPA did not identify additional wastewater treatment capable of further reducing PAC concentrations.

Table 6-21. Concentrations of PACs Reported to PCS

Chemical	Concentration Range, mg/L	Median Concentration, mg/L	Effluent Limitation, mg/L ¹	Minimum Level mg/L ²
Benzo(a)pyrene	0 - 0.00367	0.00183	0.023	0.020
Benzo(b)fluoranthene	0 - 0.00352	0.00176	0.023	0.020
Benzo(a)anthracene	0 - 0.00135	0.000676	0.022	0.020
Benzo(k)fluoranthene	0 - 0.00350	0.00181	0.022	0.020
Chrysene	0 - 0.00202	0.00101	0.022	0.020
Fluoranthene	0.00220 - 0.00400	0.00310	0.025	0.020

NA - Not applicable.

¹BAT effluent limitation for Subcategory I, direct dischargers with biological treatment in place.

²Source: EPA, *Development Document for the Central Waste Treatment Point Source Category*, 2000.

For the five facilities listed in Tables 6-19 and 6-20, EPA reviewed TRI and PCS data for additional pollutants discharged by the facilities (pollutants of concern). These pollutants, listed in Table 6-22, account for 95 percent of the TWPE for Focus Group 1.

Table 6-22. Pollutants of Concern for Coal Tar Refiners

Pollutant	2000 Discharges		Percentage of Total TWPE for Source	Number of Facilities Reporting Pollutant	Median per Facility Load (lb/yr)
	Pounds	TWPE			
TRI Data					
Polycyclic Aromatic Compounds	190	812,115	99.94%	4	35
PCS Data					
Benzo(a)pyrene	2.1	9,148	80.7%	1	NA
Benzo(b)fluoranthene	2.0	854	7.5%	1	NA
Acrylonitrile	414	353	3.1%	1	NA
3,4-Benzofluoranthene	0.68	285	2.5%	1	NA
Cyanide, Total (As CN)	210	226	2.0%	3	64

Sources: *TRIRelases2000* and *PCSLoads2000*.

All of the pollutants of concern in Table 6-22 are regulated by the existing OCPSF effluent guideline, except for PACs. Some individual PACs compounds are regulated by OCPSF.

6.6.4 Wastewater Treatment

EPA obtained wastewater treatment data from the TRI database for coal tar refiners. Of the nine coal tar refining facilities that reported to TRI for 2000, six reported wastewater treatment. All six reported having biological treatment. Also, EPA contacted four of these six facilities and asked what type of biological wastewater treatment was in place. These four facilities use conventional biological treatment, including primary clarification, activated sludge systems, and secondary clarification. See the telecons in the docket for complete documentation of the phone conversations.

6.6.5 Industry Trends

Four of the 10 plants presented in Table 6-18 have shut down since 2000, and other data indicate a decline by-product cokemaking in the United States. Koppers authored two similar articles documenting the declining availability of coal tar in North America, entitled, *Developing Coal Tar Pitches and Strategies for a Declining North American Coal Tar Supply*. Table 6-23 shows the Koppers estimates of coal tar raw material availability for 1997 - 1999, and the Koppers projected trends for 2000, 2001, and 2003.

Table 6-23. Production Trend for Cokemaking and Coal Tar Pitch

Year	North American Coal Tar Available, 1,000 metric tons/year
1997	1302
1998	1141
1999	1141
2000	1141
2001	1027
2003	1027

Source: Koppers.

In its articles, Koppers also reports on the possibility of switching feedstock from coking coal tar to a blend of coking and petroleum coal tar. The articles conclude that coal tar pitch quality is not affected by switching to a coke/petroleum coal tar blend, but different ratios will affect burning temperature. Although the availability of coal tar may be declining, the demand for coal tar pitch may be met with new feedstocks. Therefore, the coal tar refining industry may not decrease its production, but the changed feedstock may generate different pollutants.

6.6.6 Conclusions

The screening-level analysis showed high TWPE discharges from this industry group, based on releases of PACs reported to TRI. However, PCS data show that discharge concentrations for individual PACs are at levels close to or less than the minimum level and less than the current BAT limitations. The BAT limitations are already close to the minimum level, and EPA would likely not be able to lower them once analytical variability is taken into account. Furthermore, this industry is currently declining. Therefore, based on the pollutants of concern identified and their low discharge concentrations, the small number of facilities currently operating, and the apparent decline in the industry, EPA has determined that it should not revise effluent limitations guidelines and standards (ELGs) for the coal tar refining sector of the OCPSF industry at this time. If EPA receives data during subsequent annual reviews that indicate otherwise, EPA might reconsider this sector of OCPSF for revision at that time.

6.7 Focus Group 2 - Aniline Dischargers

Aniline releases were reported to TRI by 15 facilities that manufacture aniline or dyes, particularly diazo dyes. Aniline ($C_6H_5NH_2$) is a benzene molecule with an amino substitution. Aniline is not a priority pollutant, and there is no OCPSF limitation or standard for aniline. This section discusses EPA's findings on the aniline dischargers in the following subsections:

- Section 6.7.1 presents the facilities identified as aniline dischargers;
- Section 6.7.2 describes the process of aniline manufacturing and dye manufacturing and the sources and type of wastewater generated by aniline and dye manufacturing;
- Section 6.7.3 lists the pollutants of concern identified based on available data;
- Section 6.7.4 lists the wastewater treatment-in-place based on available data; and
- Section 6.7.5 presents EPA's conclusions.

6.7.1 Facilities

EPA estimates that 8 facilities manufacture aniline (11) and 38 facilities manufacture dyes (1). EPA obtained discharge data from 15 facilities that reported discharging aniline to TRI in 2000. (The remaining facilities did not report aniline discharges to TRI). These facilities report under SIC code 2865, Cyclic Organic Crudes and Intermediates, and Organic Dyes and Pigment. EPA determined the types of products manufactured at each facility through telephone calls and searches of company web pages, in addition to the National Safety Council (NSC) Chemical Backgrounder on aniline (which lists aniline manufacturers). Two

facilities reported aniline discharge information to PCS. Table 6-24 lists the facilities with TRI data (which includes the two facilities with PCS data).

Table 6-24. OCPSF Aniline Dischargers in the United States

Company	Location	Product Type ¹	Discharge Status
BASF Corporation	Huntington, WV	Alkali blue.	Indirect
Buffalo Color Corporation	Buffalo, NY	Dyes and pigments.	Indirect
Chicago Specialties LLC	Chicago, IL	Styrene, printing ink and pigments, organic dyes and pigments, nitriles, aromatics.	Indirect
Sun Chemical Corporation Muskegon Plant	Muskegon, MI	Organic pigments, cosmetics, plastics, printing inks.	Indirect
Crompton Colors Inc.	Newark, NJ	Olefins and styrenic additives; petroleum additives.	Indirect
CIBA Specialty Chemicals Corporation	Newport, DE	Commodity organic chemicals: phenol, acetone, bis-phenol(a). No longer manufacture aniline (did in 2000). No manufacture of pigments, inks, or dyes at this location.	Indirect
H & S Chemical Company Inc.	Wallington, NJ	Pigments, dyes, other organic chemicals.	Indirect
First Chemical Corporation	Pascagoula, MS	DuPont runs this plant. Manufactures aniline, nitrotoluene (various isomers), and other specialty and commodity chemicals.	Indirect
Orient Corporation of America	Seaford, DE	Pigments, dyes, other organic chemicals.	Indirect
Aristech Chemical Corporation	Haverhill, OH	Aniline, other organic chemicals.	Direct
Bayer Corporation Bushy Park Plant	Goose Creek, SC	Pigments, dyes, other organic chemicals.	Direct
Nation Ford Chemical Co.	Fort Mill, SC	Pigments and dyes, mainly carbazole violet pigment #23 and diazo dyes. Also isopropyl alcohol.	Indirect
Morton International Inc. Paterson Facility	Paterson, NJ	Pigments, dyes, other organic chemicals.	Indirect
Merisol USA LLC	Houston, TX	Pigments, dyes, other organic chemicals.	Direct

Table 6-24 (Continued)

Company	Location	Product Type ¹	Discharge Status
Lomac LLC	Muskegon, MI	Pigments, dyes, other organic chemicals.	Indirect

Source: *TRI Releases 2000*.

¹EPA determined the type of product made at each facility through telephone calls, searches of company web pages, and the National Safety Council Chemical Backgrounder for aniline.

6.7.2 Process Description and Wastewater Sources

Aniline discharges result from the manufacture of aniline as well as the manufacture of certain dyes, azo dyes in particular. Section 6.7.2.1 discusses aniline production and Section 6.7.2.2 discusses azo dye production.

6.7.2.1 Aniline Production

The most common method for industrial production of aniline is nitrobenzene hydrogenation. The reaction may be carried out in a liquid- or vapor-phase.

Nitrobenzene Hydrogenation Reaction:

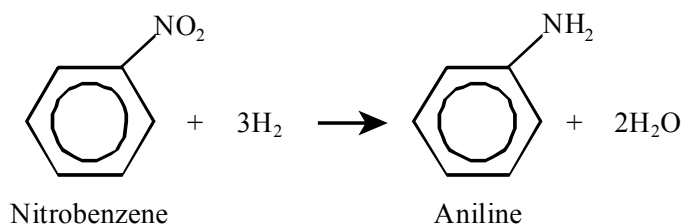

In the vapor-phase process, nitrobenzene ($\text{C}_6\text{H}_5\text{NO}_2$) vapor and hydrogen are fed into a fluidized bed reactor. Copper or copper on silica are typical catalysts for this reaction. A filter at the top of the reactor recovers catalyst particles from the product. The nitrobenzene hydrogenation reaction produces a gas containing aniline, water vapor, and residual hydrogen. The gas is condensed and sent to a phase separator. Residual hydrogen is recycled, and the water phase is sent to wastewater treatment. The aniline is fed to a distillation column for further purification (3). Figure 6-2 presents the vapor-phase process for producing aniline.

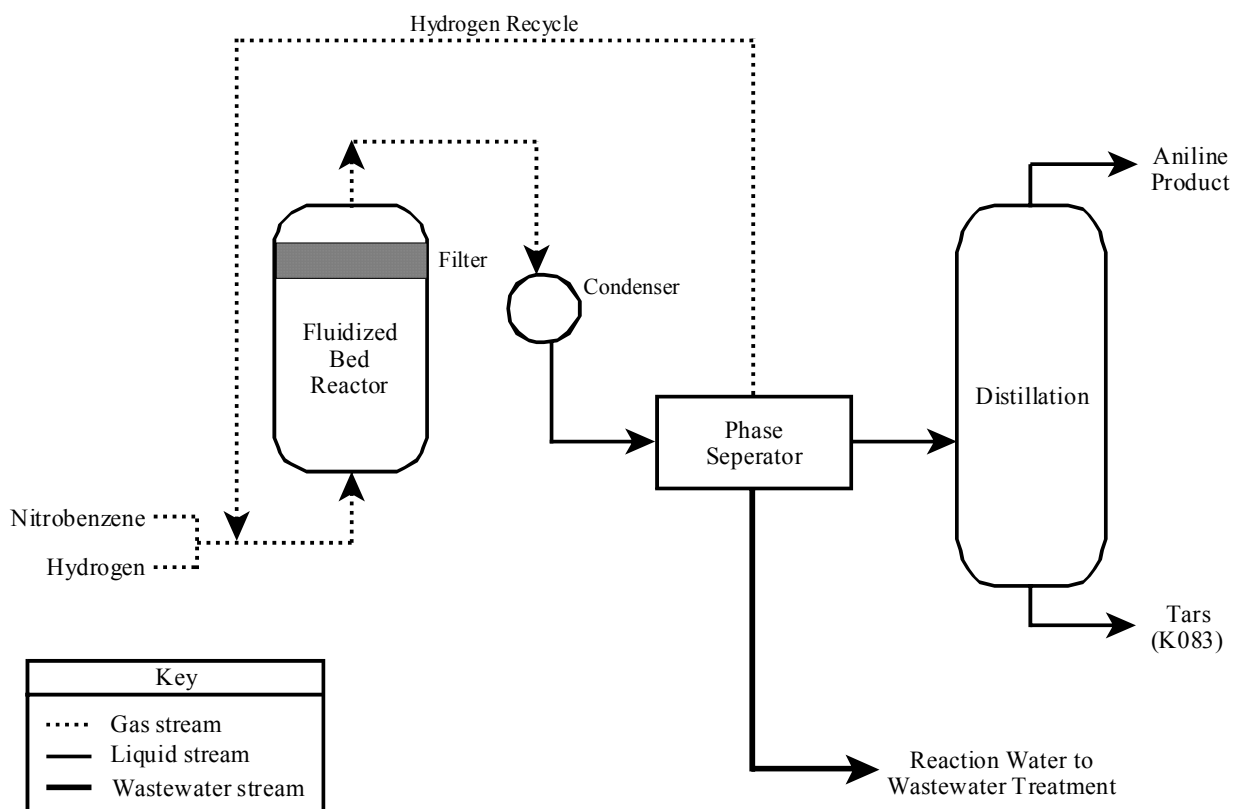

Figure 6-2. Vapor-Phase Aniline Manufacturing Process

DuPont produces aniline in a liquid-phase reaction, using nitric acid (HNO_3) and benzene as feedstocks. As a first step, nitric acid and benzene react to form mononitrobenzene (MNB). DuPont has a unique dehydrating system to remove the water that is produced from the reaction. An inert gas passes through the reactor and removes the reaction water. The humidified gas stream is condensed to remove the water, and the inert gas is recycled through the reactor. Crude MNB is washed and distilled. Residual benzene is removed during this distillation step and recycled to the feed. MNB and hydrogen are fed into a plug flow reactor. Typically, noble metal catalysts, such as platinum or palladium, are used in this reaction. The product stream is sent to a dehydration column to remove water formed during the reaction. A second column removes heavy ends from the aniline product (Hydrocarbon Processing). Sources of wastewater in this process include inert gas condensates, MNB wash water, and reaction water removed in the dehydration column. Figure 6-3 presents the DuPont/KBR liquid-phase process.

In aniline production, the following waste streams are listed as hazardous wastes:

- K083: Distillation bottoms from aniline production;

6-40

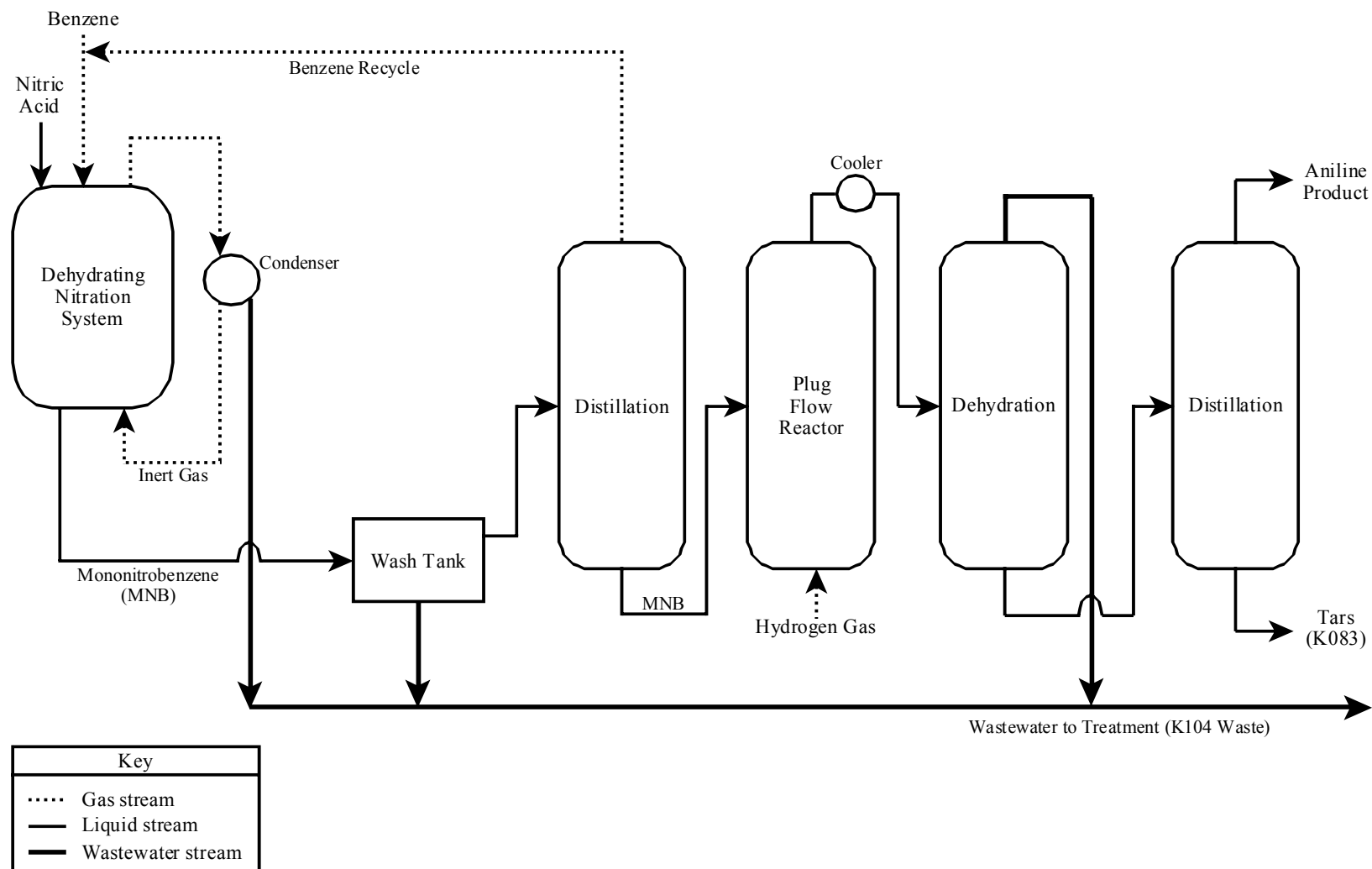

Figure 6-3. Dupont/KBR Liquid-Phase Aniline Process

- K103: Process residues from extraction of aniline during aniline production; and
- K104: Combined wastewater streams generated from nitrobenzene/aniline production.

These wastes were listed because they failed the toxicity characteristic for aniline, diphenylamine, nitrobenzene, and phenylenediamine (all three wastes), and K104 also failed for benzene. RCRA requires facilities to manage their K104 wastewater in certain ways. For example, wastewater treatment systems used to treat K104 waste may need permitting, and facilities must ensure no media transfer of pollutants occurs. However, the RCRA regulation of K104 waste does not apply to effluent wastewater quality, which is regulated by Clean Water Act regulations, including the ELGs for OCPSF.

6.7.2.2 Azo Dye Manufacturing

Azo dyes are formed by diazotization and coupling reactions. In the diazotization reaction, an aromatic amine and nitrous acid react to form a diazonium salt. An example of these reactions is shown below using 4-nitroaniline as the aromatic amine and 2-naphthol as the nucleophilic reagent.

Diazotization and Coupling Reactions:

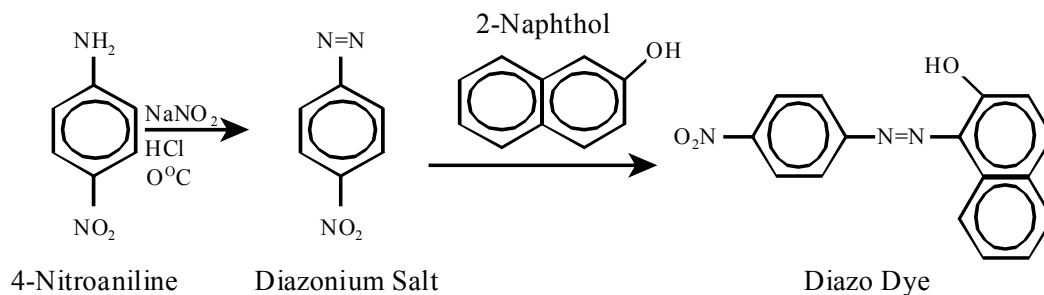

In the dye manufacturing process, shown in Figure 6-4, the diazotization reaction takes place in a liquid-phase reactor. The reactor effluent is treated in a clarifier prior to the coupling reactor, where the diazonium salt is converted to a diazo dye by a nucleophilic substitution reaction. Depending on the specific dye being produced, the product stream from the coupling reaction might be sent through esterification or isolation. A filter press removes water from the dye product. The final processing steps involve grinding and packaging the dye. Sources of wastewater include spent scrubber liquid, mother liquor, plant run-off, and equipment washdown (16).

6-42

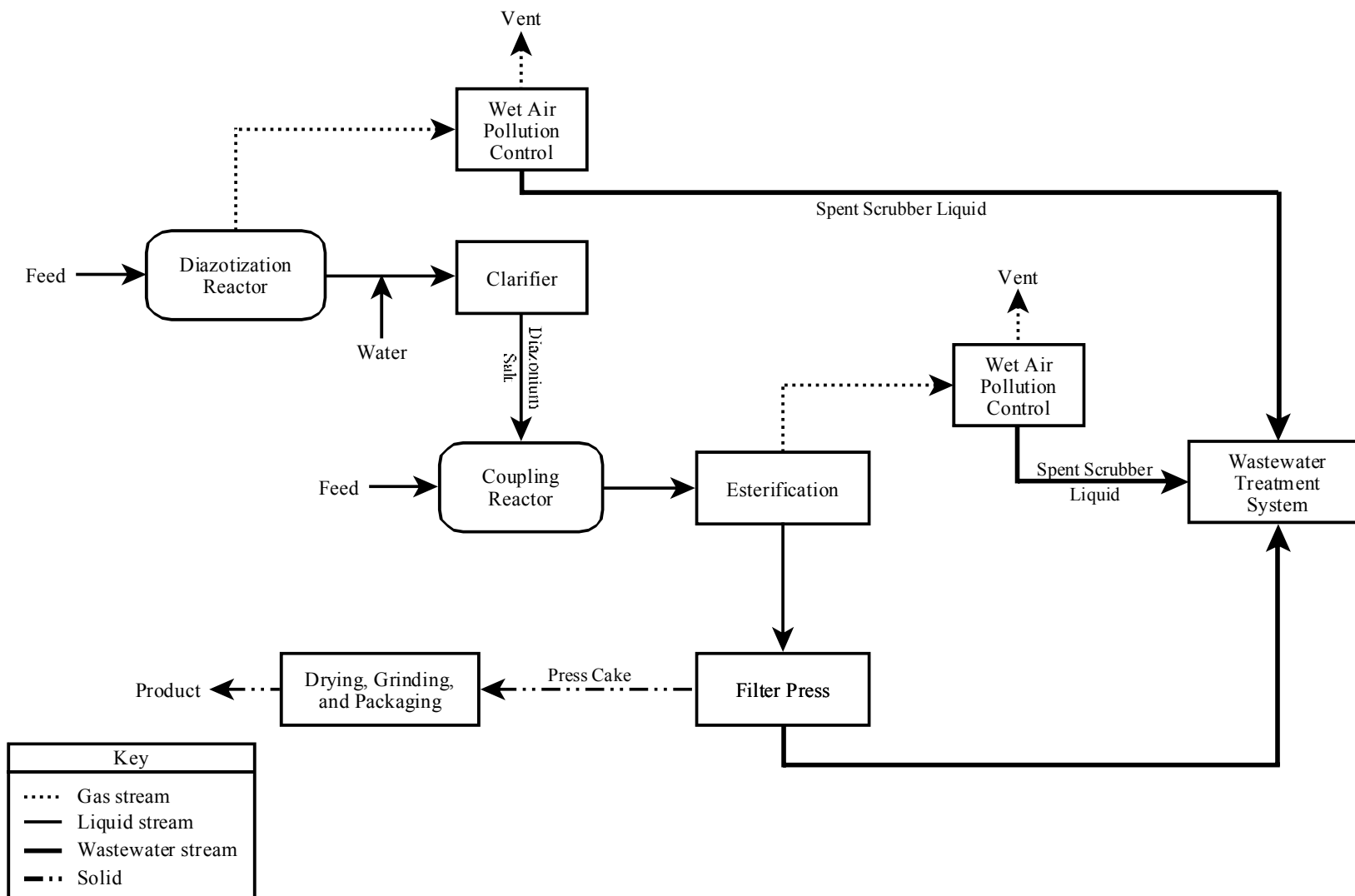

Figure 6-4. Azo Dye Manufacturing Process

6.7.3 Pollutants of Concern

EPA obtained aniline discharge data, presented in Table 6-25, from 15 facilities that reported to TRI 2000. PCS includes aniline discharge information for two facilities: Buffalo Color and Aristech Chemical. The other facilities either do not have permit limits for aniline (there is no OCPSF limitation or standard for aniline) or are indirect dischargers.

Table 6-25. Aniline Discharges Reported to TRI and PCS in 2000 for SIC Code 2865

Name	Location	TRI (lbs/yr) ^{1,2}	TRI (TWPE/yr) ^{1,2}	PCS ³ (lbs/yr)	PCS ³ (TWPE/yr)
BASF Corporation	Huntington, WV	37,223	52,332		
Buffalo Color Corporation	Buffalo, NY	16,394	23,049		
		255	359	594	835
<i>Chicago Specialties LLC</i>	<i>Chicago, IL</i>	<i>6,478</i>	<i>9,107</i>		
Sun Chemical Corporation, Muskegon Plant	Muskegon, MI	2,610	3,670		
Crompton Colors Inc.	Newark, NJ	2,432	3,419		
CIBA Specialty Chemicals Corporation	Newport, DE	2,179	3,064		
H & S Chemical Co. Inc.	Wallington, NJ	225	316		
First Chemical Corporation	Pascagoula, MS	216	304		
Orient Corporation of America	Seaford, DE	51	72		
Aristech Chemical Corporation	Haverhill, OH	22	31	0	0
Bayer Corporation, Bushy Park Plant	Goose Creek, SC	2	3		
Nation Ford Chemical Co.	Fort Mill, SC	1	2		
	Fort Mill, SC	1	1		
Morton International Inc., Paterson Facility	Paterson, NJ	1	2		
Merisol USA LLC	Houston, TX	1	1		
Lomac LLC	Muskegon, MI	1	1		

Source: *PCSLoads2000* and *TRIRelases2000*.

¹The TWPE loads presented for indirect dischargers represent the estimated discharge to the receiving stream. For indirect dischargers, EPA estimated that POTWs would remove 92.1 percent of aniline in wastewater.

²Two facilities, Buffalo Color and National Ford Chemical, reported both direct and indirect discharges.

³Only two facilities reported aniline discharges in PCS, and one of these discharges was reported as zero. *Italics* denote facilities no longer in operation.

Table 6-26 presents the aggregated TRI data.

Table 6-26. Aniline Discharges Reported to TRI

	Number of Facilities ¹	Aniline TWPE	Total TWPE
Direct Dischargers	3	35	1,380
Indirect Dischargers ²	12	118,000	121,000
Total	15	119,000	123,000

Source: *TRIRelases2000*.

¹Two direct dischargers reported some indirect discharge of aniline to TRI, which was insignificant compared to the direct discharge amount.

²The TWPE loads presented here represent the estimated discharge to the receiving stream. For indirect dischargers, EPA estimated that POTWs would remove 92.1 percent of aniline in wastewater.

As discussed in Section 6.3.4.1, EPA determined that aniline was the pollutant with the third largest TWPE in the OCPSF category. In addition, all 15 aniline dischargers were in SIC code 2865 and manufactured either aniline or dyes. For the 15 facilities in Table 6-21, EPA determined the other pollutants of concern that were reported as discharged to TRI and PCS. Table 6-27 shows the pollutants reported with the highest TWPE, noted as the pollutants of concern for Focus Group 2 – Aniline Dischargers. Note that the PCS data for Focus Group 2 show that benzo(a)pyrene, reported by one direct discharge facility, contributes 84 percent of the TWPE for Focus Group 2, whereas aniline is an insignificant part (less than 0.1 percent) of the TWPE. These data show that besides aniline, these facilities do not discharge a uniform set of pollutants of concern with high TWPE.

Table 6-27. Pollutants of Concern for Aniline Dischargers

Pollutant	Discharge (lb/yr)	TWPE	Percentage of Total TWPE	Number of Facilities Reporting Pollutant	Median per Facility Load (lb/yr)
TRI Data					
Aniline	84,745	119,143	97.0%	15	216
PCS Data					
Benzo(a)pyrene	25	106,385	83.8%	1	NA
3,4-Benzofluoranthene	25	10,465	8.2%	1	NA
Aniline	2	35	<0.1%	1	NA

Source: *PCSLoads2000* and *TRIRelases2000*.

6.7.4 Wastewater Treatment

Most Focus Group 2 facilities are indirect dischargers, meaning their wastewater goes through a municipal wastewater treatment plant that uses biological treatment. Approximately 80 percent (12 out of 15) of the facilities reporting aniline releases to TRI in 2000 reported indirect discharges. Biological treatment is expected to effectively remove greater

than 90 percent of aniline in wastewater, as confirmed in the U.S. EPA National Risk Management Research Labs (NRMRL) treatability database (20) and vendor information.

EPA generally establishes pretreatment standards if a pollutant interferes with or passes through POTWs. In previous effluent guidelines, EPA found that aniline did not require pretreatment standards. For example, for the pharmaceuticals industry effluent guideline, based on biological treatment, EPA found that aniline does "not pass through POTWs or interfere with the treatment works." (63 FR 50387 to 50437, September 21, 1998).

To determine if aniline discharges from OCPSF operations caused problems at POTWs, EPA contacted five POTWs that receive discharges of aniline from seven of the aniline-discharging facilities. EPA selected the POTWs that receive the greatest pounds of aniline reported to TRI. These included both large and small POTWs. EPA asked the POTWs what aniline discharges they were aware of receiving, and if any of these discharges interfere with POTW operation. Table 6-28 lists the facilities that discharge indirectly and their respective POTWs. EPA received responses from all five POTWs. All five POTWs reported that, although aniline is detected in wastewater from dye and aniline manufacturers (at concentrations ranging from approximately 300 to 1,200 mg/L), they have not had interference problems, and the aniline appears adequately treated.

Table 6-28. Facilities That Discharge Indirectly and Their Respective POTWs

Company	Location	POTW Name	POTW Flow (MGD)	Information Request Sent to POTW?
BASF Corporation	Huntington, WV	Huntington POTW	14	Yes
Buffalo Color Corporation	Buffalo, NY	Buffalo POTW	0.54	Yes
Chicago Specialties LLC	Chicago, IL	Chicago POTW	32	
Sun Chemical Corporation Muskegon Plant	Muskegon, MI	Muskegon County POTW	65	Yes
Crompton Colors Inc.	Newark, NJ	Passaic Valley POTW	NA	Yes
CIBA Specialty Chemicals Corporation	Newport, DE	Wilmington, DE POTW	83	Yes
H & S Chemical Co. Inc.	Wallington, NJ	Passaic Valley POTW	NA	Yes
First Chemical Corporation	Pascagoula, MS	Pascagoula POTW	4.4	
Orient Corporation of America	Seaford, DE	Seaford POTW	1.1	
Nation Ford Chemical Co.	Fort Mill, SC	Rock Hill POTW	8.8	
Morton International Inc. Paterson Facility	Paterson, NJ	Passaic Valley POTW	NA	Yes

Table 6-28 (Continued)

Company	Location	POTW Name	POTW Flow (MGD)	Information Request Sent to POTW?
Lomac LLC	Muskegon, MI	Muskegon County POTW	65	

Sources: *TRIReleases2000* and *PCSLoads2000* (for POTW flow data).

NA - Indicates that no POTW flow data were available in PCS.

Note: Three facilities reported discharges to the Passaic Valley POTW, and two reported discharges to the Muskegon POTW.

6.7.5 Conclusions

The screening-level analysis showed high TWPE discharges from OCPSF Focus Group 2 relative to other OCPSF discharges, and the TWPE was driven by aniline discharges. Most of these facilities are indirect dischargers. EPA contacted five POTWs who receive discharges from some of the facilities in Table 6-24, and three of these POTWs reported no known interferences with their treatment systems. Because of the high treatability of aniline and the lack of POTW interference, EPA determined that it should not consider revising pretreatment standards for the aniline-discharging focus group (i.e., aniline manufacturers and dye manufacturers) of the OCPSF industry at this time.

In addition, because only three facilities discharge aniline directly and because these discharges appear to be low relative to the other facilities in this sector, EPA determined that it should not consider revising direct discharge requirements for the aniline discharging focus group at this time.

EPA notes, however, that if it receives data during subsequent annual reviews that indicate otherwise, EPA may reconsider this sector of OCPSF for revision at that time.

6.8 Focus Group 3: Dioxin Dischargers

Based on analysis of TRI and PCS data, as well as information from industry studies, EPA identified the manufacture of the following products as possible sources of dioxin discharges: ethylene dichloride (EDC), vinyl chloride monomer (VCM), and polyvinyl chloride (PVC). EPA refers to these collectively as vinyl chloride manufacturing. Further, EPA found that the largest dioxin discharges (97 percent of the toxic pound equivalents) occur at large integrated facilities that also operate chlor-alkali plants. Wastewaters from chlor-alkali plants are subject to the Inorganic Chemicals effluent guidelines (Part 415). Dioxin discharges are also significant at facilities that manufacture vinyl chloride without co-located chlor-alkali plants and at stand-alone chlor-alkali plants. EPA also found that some reported dioxin discharges are associated with organic chemicals manufacturing processes other than vinyl chloride manufacturing and chlor-alkali plants, including chlorinated solvents production.

EPA identified various products manufactured by OCPSF facilities that discharge dioxins. EPA found that most dioxin dischargers manufactured one or more of three products: 1) chlor-alkali, 2) EDC/VCM, and 3) PVC. Therefore, for Focus Group 3, EPA reviewed those facilities with chlor-alkali, EDC/VCM, and/or PVC manufacturing processes.

This section discusses EPA's findings on the dioxin dischargers in the OCPSF category in the following subsections:

- Section 6.8.1 presents the facilities identified as chlorine manufacturers (including those with chlor-alkali plants), EDC/VCM manufacturers, PVC manufacturers, and manufacturers of other organic chemicals including chlorinated solvents;
- Section 6.8.2 describes the chlor-alkali, EDC/VCM, and PVC processes;
- Section 6.8.3 describes sources and type of wastewater generated by chlor-alkali, EDC/VCM, and PVC processes;
- Section 6.8.4 lists the pollutants of concern identified based on available data;
- Section 6.8.5 lists the wastewater treatment-in-place based on available data; and
- Section 6.8.6 describes industry trends.

6.8.1 Facilities

EPA identified the manufacturing processes of the following products as sources of dioxin:

- Chlor-alkali;
- EDC/VCM;
- PVC; and
- Other organic chemicals including chlorinated solvents.

EPA identified facilities in Focus Group 3 from the TRI and PCS databases and the CCC web page, as well as reports from the Vinyl Institute and Chlorine Institute. EPA identified the following manufacturing groups and the number of facilities in each group:

- Stand-alone chlor-alkali facilities: 24;
- Integrated chlor-alkali and EDC/VCM facilities (may also produce PVC): 12;

- Stand-alone EDC/VCM facilities (may also produce PVC): 2; and
- Stand-alone PVC facilities: 18.

Table 6-29 lists facilities in Focus Group 3 and the products they manufacture. Note that OCPSF facilities that reported the highest discharges of dioxin to TRI have multiple operations, including chlor-alkali plants and EDC/VCM operations.

Table 6-29. OCPSF Dioxin Dischargers in the United States

Company	Location	Product Type	Discharge Status
Ashta	Ashtabula, OH	Chlorine	No reported discharge ¹
Bayer	Baytown, TX	Chlorine	Direct/Major
Certainteed Corporation	Westlake, LA	PVC	Direct/Major
Colorite Specialty Resins	Burlington, NJ	PVC	Direct/Major
Dow Chemical	Freeport, TX ²	Chlorine, EDC	Direct/Major
	Plaquemine, LA	Chlorine, EDC	Direct/Major
	Texas City, TX	PVC	Indirect
DuPont	Niagara Falls, NY	Chlorine	Direct/Major
Formosa Plastics	Baton Rouge, LA	Chlorine, EDC, VCM, PVC	Direct/Major
	Delaware City, DE	PVC	Direct ¹ /Major
	Illioopolis, IL ³	PVC	Direct/Major
	Point Comfort, TX	Chlorine, EDC, VCM, PVC	Direct/Major
GE Plastics	Burkville, AL	Chlorine	Direct ¹ /Major
	Mount Vernon, IN	Chlorine	Direct/Major
<i>Geismar Vinyls</i>	<i>Geismar, LA⁴</i>	<i>EDC, VCM, PVC</i>	<i>Direct/Major</i>
Georgia Gulf	Aberdeen, MS	PVC	Indirect
	Oklahoma City, OK	PVC	Direct ¹ /Major
	Plaquemine, LA	Chlorine, EDC, VCM, PVC	Direct/Major
	Westlake, LA	EDC,	Transfer to Sasol North America
Georgia Pacific	Green Bay, WI	Chlorine	Direct ¹ /Major
	<i>Muskogee, OK⁵</i>	<i>Chlorine</i>	<i>Direct/Major</i>
	Rincon, GA	Chlorine	Direct/Major
<i>Keysor Century</i>	<i>Geismar, LA⁶</i>	<i>PVC</i>	<i>Indirect</i>
Kuehne	Kearny, NJ	Chlorine	Direct ¹ /Minor

Table 6-29 (Continued)

Company	Location	Product Type	Discharge Status
Occidental Chemical Company	Convent, LA	Chlorine, EDC	Direct/Major
	Delaware City, DE	Chlorine	Direct/Major
	Ingleside, TX	Chlorine, EDC	Direct/Major
	Hahnville, LA	Chlorine	Direct/Major
	Mobile, AL	Chlorine	Direct ¹ /Major
	Niagara Falls, NY	Chlorine	Both /Major
	Pottstown, PA	PVC	Indirect
Olin	Augusta, GA	Chlorine	Direct/Minor
	Charleston, TN	Chlorine	Direct/Major
	McIntosh, AL ⁷	Chlorine	No reported discharge ¹
	Niagara Falls, NY	Chlorine	Direct ¹ /Major
OxyVinyls	<i>Deer Park, TX⁸</i>	<i>Chlorine, EDC, VCM, PVC</i>	<i>Direct/Major</i>
	LaPorte, TX	Chlorine, EDC, VCM, PVC	Direct ¹ /Major
	Louisville, KY	PVC	No reported discharge ¹
	Pasadena, TX	PVC	Direct/Major
	Pedricktown, NJ	PVC	Direct/Major
Oxychem	Muscle Shoals, AL	Chlorine	Direct ¹ /Major
Pioneer	Henderson, NV	Chlorine	Direct ¹ /Major
	St. Gabriel, LA	Chlorine	Direct
	Tacoma, WA ⁹	Chlorine	Direct ¹ /Major
Polyone Corporation	<i>Burlington, NJ¹⁰</i>	<i>PVC</i>	<i>Direct¹/Minor</i>
	Henry, IL	PVC	No reported discharge ¹
PPG Industries, Inc.	Lake Charles, LA	Chlorine, EDC	Direct
	Natrium, WV	Chlorine	Direct
Shintech Inc.	Addis, LA ¹¹	PVC	Direct ¹ /Major
	Freeport, TX	PVC	Direct/Minor
Vulcan	Geismar, LA	Chlorine, EDC	Direct
	Port Edwards, WI	Chlorine	No reported discharge ¹
	Wichita, KS	Chlorine	No reported discharge ¹
Vygen	<i>Ashtabula, OH¹²</i>	<i>PVC</i>	<i>No reported discharge¹</i>

Table 6-29 (Continued)

Company	Location	Product Type	Discharge Status
Westlake Monomers	Calvert City, KY	Chlorine, EDC	Direct ¹ /Major
	<i>Pensacola, FL¹³</i>	<i>PVC</i>	<i>No reported discharge¹</i>

Sources: Chlorine Chemistry Council web page, Chlorine Institute Report, Vinyl Institute Report, Innovation Group web page, Chemical Backgrounders web page, *TRI Releases 2000* and *PCS Loads 2000*, and individual company web pages.

Italics indicate that the facility has been idled or closed.

¹No releases of TRI chemicals to surface water or transfers to POTWs were reported to TRI for 2000.

²Dow Chemical Oyster Creek is considered part of the Freeport plant.

³Formosa Plastics purchased the Illiopolis plant from Borden in 2002.

⁴Giesmar Vinyls, an affiliate of Westlake Group, purchased Borden's vinyl operations. Plants were idled in 2002.

⁵The Georgia Pacific Muskogee, OK plant was idled, according to a phone conversation with Steve Landers, 6/9/04.

⁶Keysor Century closed in 2003.

⁷Olin's McIntosh, AL site also includes the Sunbelt joint venture chlor-alkali plant.

⁸The Oxy Vinyls Deer Park, TX chlor-alkali plant was idled December 2001.

⁹The Pioneer Tacoma, WA plant was idled February 2002 according to Chlorine Institute.

¹⁰Polyone's Burlington, NJ site appears to be a vinyl compounding site. It was closed in 2002.

¹¹Shintech purchased Borden's Addis plant in 2002.

¹²The Vygen Ashtabula plant appears to be shut down as of 1993.

¹³The Westlake Pensacola plant appears to be shut down.

EPA also identified 11 OCPSF facilities reporting dioxin discharges that manufacture organic chlorine chemicals other than EDC, VCM, or PVC. The products made by the facilities listed in Table 6-30 could not be classified into a single group. The total dioxin TWPE from these 11 facilities is 120,000 lb-equivalent, which is less than 1 percent of the 5.7 million TWPE from Focus Group 3 (based on 2000 TRI data).

EPA also conducted economic analyses of portions of the OCPSF industry. For information about EPA's small business analysis of the chlor-alkali and vinyl chloride industries, see the August 3, 2004 Memorandum entitled OCPSF: Number of Small Businesses in Chlor-Alkali and Vinyl Chloride Industries (located in the docket). For information about EPA's economic analysis of OCPSF dioxin dischargers, see the August 13, 2004 Memorandum entitled Organic Chemicals, Plastics, and Synthetic Fiber Focus Group 3: Dioxin Dischargers—Industry Profile (located in the docket).

Table 6-30. Facilities Reporting Dioxin Discharges to TRI that Manufacture Other Organic Chemicals in the United States

Company	Location	Product Type	Discharge Status
Atofina Petrochemicals	La Porte, TX	Polypropylene.	Direct/Major
Celanese Acetate	Narrows, VA	Cellulose acetate, flake, filament, tow.	Direct/Major
Condea Vista	Baltimore, MD	Aluminum chloride LAB, muriatic acid (hydrochloric acid), specialty alkylates.	Both/Minor

Table 6-30 (Continued)

Company	Location	Product Type	Discharge Status
Cytec Industries	Wallingford, CT	Aliphatic isocyanate resins, polyurethane, meta diisopropenybenzene, adhesion polymers, formaldehyde resins, crosslinking monomers, aerosol surfactants, coating chemicals.	Direct/Major
Dover Chemical	Dover, OH	Chlorinated paraffins, surfactants, and lubricants.	No reported discharge ¹
Dow Chemical	Midland, MI	Wide range of chemical products.	Direct/Major
DuPont Chamber Works	Deepwater, NJ	Fluorochemicals, elastomers, Hytel polyester elastomer.	Direct/Major
Oxychem	Castle Hayne, NC	Copper chromated arsenate.	Direct/Major
	Lake Charles, LA	Ethylene and propylene and by-products including crude butadiene, pyrolysis gasoline, hydrogen.	No reported discharge ¹
Sasol North America, Inc.	Westlake, LA	Alcohols, alumina, ethylene, LAB, solvents, paraffins, ethoxylates.	Direct/Major
Velsicol Chemical	Memphis, TN	Benzoate esters, polymerics, and monomeric.	Indirect

Sources: *TRI Releases 2000*, individual company web pages.

¹No water discharges were reported to TRI for 2000.

6.8.2 Process Descriptions

This section discusses the processes used to manufacture the following products:

- Chlor-alkali;
- EDC/VCM; and
- PVC.

6.8.2.1 Chlor-Alkali

The chlor-alkali process is the most common method of producing chlorine, accounting for more than 95 percent of the world chlorine production (28). In addition to the chlor-alkali process, chlorine may also be produced as a co-product or by-product by four other methods (21):

- Downs Sodium Process: Molten salts, instead of brine, are electrolytically converted to chlorine;
- Uhde HCl Decomposition Process: HCl, instead of brine, is electrolytically converted to chlorine;

- Potassium Nitrate Production: Nonelectrolytic nitric acid/salt process produces chlorine as a co-product; and
- Magnesium Production: Electrolytic process produces chlorine as a by-product.

Since chlor-alkali accounts for the majority of chlorine production, and has been identified as a source of dioxin, the remainder of this section will focus on the chlor-alkali process. The process produces chlorine gas and sodium hydroxide (caustic) by passing an electric current through a sodium chloride brine solution. Although less common, potassium chloride may also be used as the feed stock to produce chlorine and potassium hydroxide. The chlor-alkali process uses three electrolytic technologies: mercury cell, asbestos diaphragm cell, and membrane cell. The diaphragm cell is the predominant technology used in the United States (5, 28).

The mechanism for separating chlorine and sodium products depends on the type of cell used (14). In the mercury cell process, mercury forms an amalgam with the sodium. The amalgam flows from the cell to the decomposer, where it reacts with water to form sodium hydroxide, hydrogen gas, and mercury. Figure 6-5 shows the chlor-alkali process using a mercury cell.

In the asbestos diaphragm process, sodium ions selectively permeate an asbestos barrier. The membrane cell process is similar to the diaphragm cell process except that an ion exchange membrane replaces the diaphragm. In both processes, sodium ions react with water to form sodium hydroxide and hydrogen gas. Figure 6-6 shows the chlor-alkali process using a diaphragm or membrane cell.

Prior to its use in the electrolytic cell, the sodium chloride brine is treated to remove any metal impurities. The metals are precipitated using caustic solutions and exit the brine preparation system as a slurry. This slurry is filtered, and the water is sent to wastewater treatment (21). The solid waste is called “brine muds” and is a listed hazardous waste for mercury and diaphragm cells. In the chlorine production process, the following wastes are listed hazardous wastes:

- K071: Brine purification muds from the mercury cell process in chlorine production, where separately prepurified brine is not used;
- K073: Chlorinated hydrocarbon waste from the purification step of the diaphragm cell process using graphite anodes in chlorine production; and

6-53

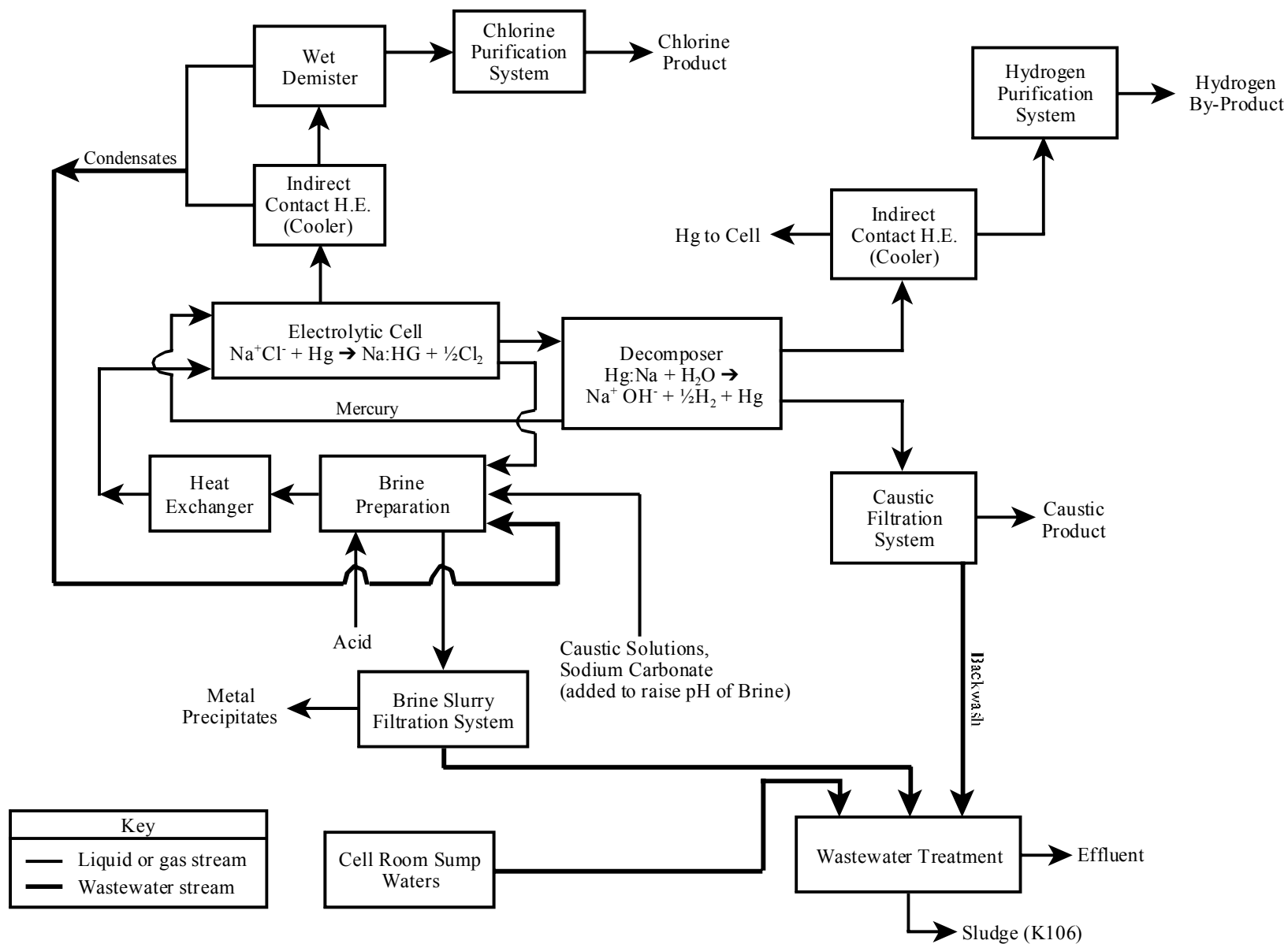

Figure 6-5. Mercury Cell Chlor-Alkali Process

6-54

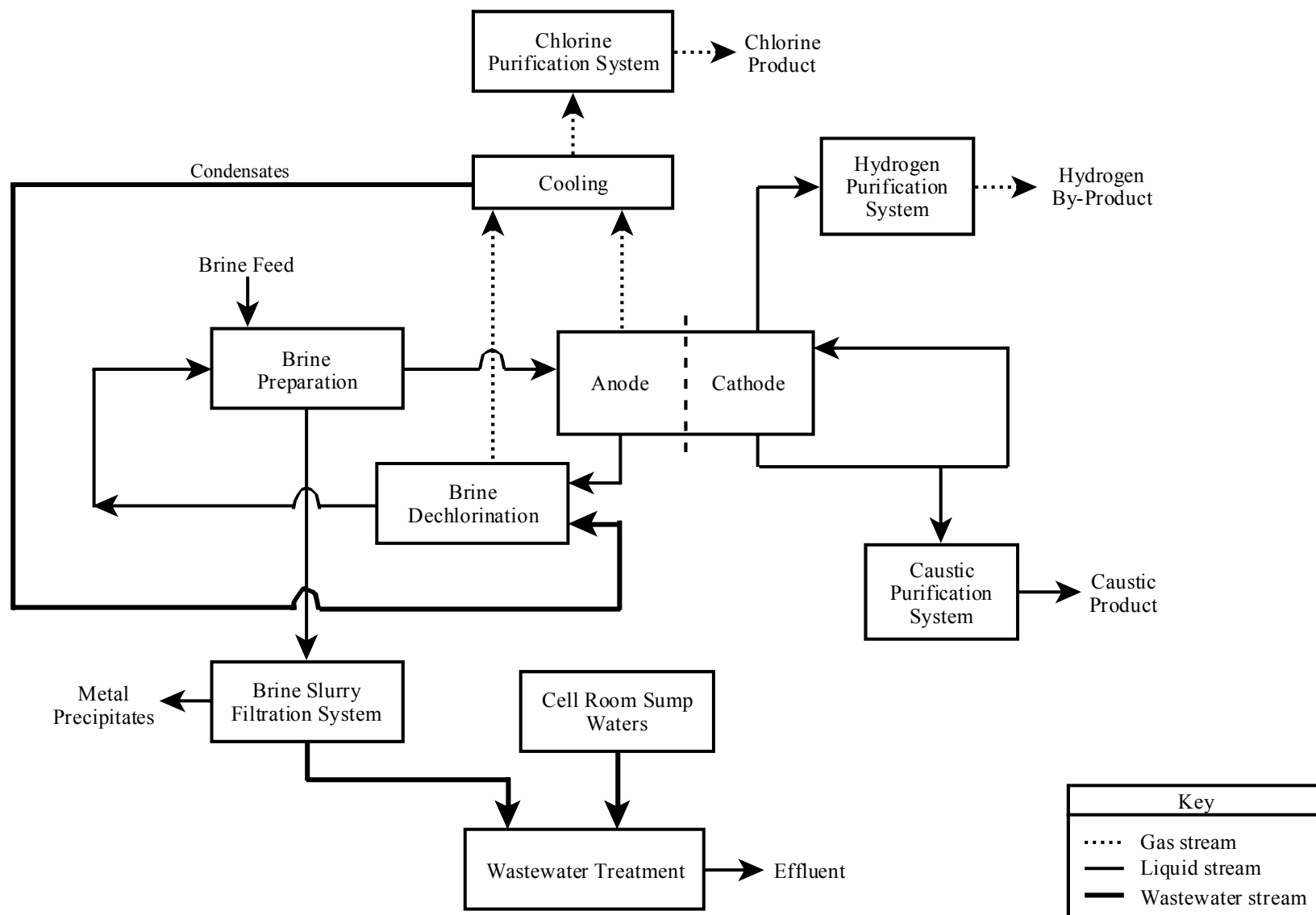

Figure 6-6. Membrane or Diaphragm Cell Chlor-Alkali Process

- K106: Wastewater treatment sludge from the mercury cell process in chlorine production.

6.8.2.2 Ethylene Dichloride and Vinyl Chloride Monomer

More than 80 percent of the EDC produced in the U.S. is used for the production of VCM. The process of producing VCM, where EDC production is an intermediate step, is known as the “balanced process,” shown in Figure 6-7. In the balanced process, EDC is produced by direct chlorination and oxychlorination:

1) Direct Chlorination:

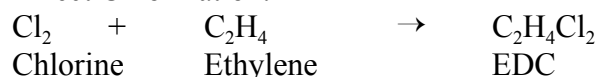

2) Oxychlorination:



In direct chlorination, ethylene is reacted with chlorine gas in the presence of a catalyst (usually iron chloride) at temperatures ranging from 50°C to 70°C (25). This reaction typically occurs in a liquid-phase reactor.

In oxychlorination, the reaction utilizes the HCl by-product from VCM production, conserving the use of raw materials such as chlorine gas. Reactors are typically fixed or fluidized beds with a copper chloride catalyst. The exothermic reaction is carried out in three steps at temperatures exceeding 200°C (9):

1) Chlorination of ethylene:

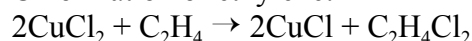

2) Oxidation of CuCl:

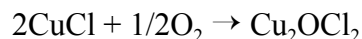

3) Rechlorination with HCl:

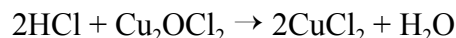

The reactor effluent is quenched and condensed before combining with the EDC produced from direct chlorination. The combined crude EDC product is fed through a series of distillation columns before it is sent to the EDC cracking furnace to produce VCM. All VCM plants using the EDC cracking reaction are integrated with EDC production facilities (25). The EDC cracking reaction (dehydrochlorination), shown below, is carried out in a furnace at temperatures ranging from 450°C to 650°C (25):

6-56

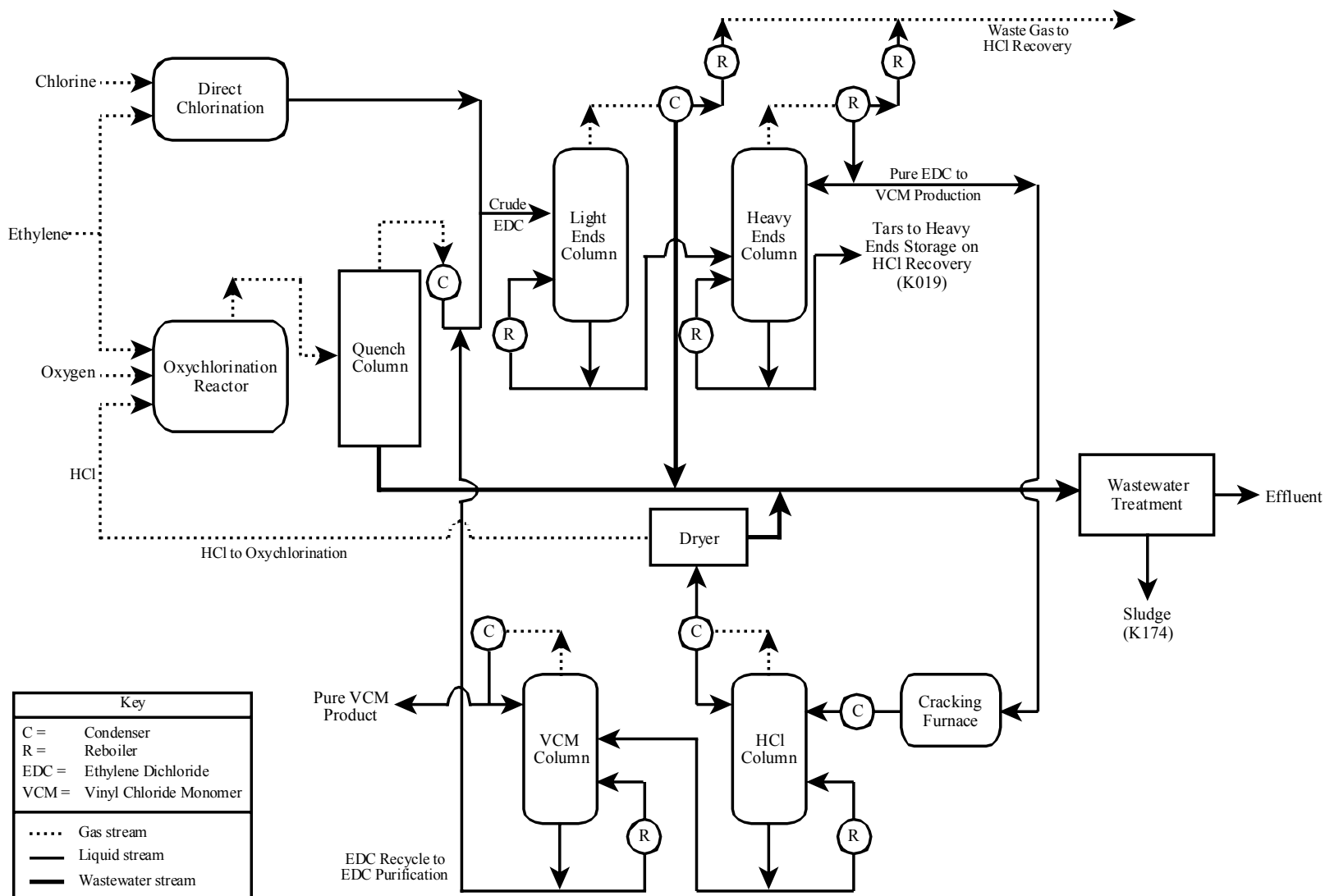

Figure 6-7. Flow Diagram for EDC/VCM Balanced Process

Dehydrochlorination:



The dehydrochlorination reaction produces a gas containing vinyl chloride, unconverted EDC, and HCl. This gas is quenched and condensed before passing through a series of distillation columns. HCl is removed in the first column and recycled to the oxychlorination reaction. Unconverted EDC is removed in the second column and recycled through EDC purification before reentering the cracking furnace.

The heavy and light ends from the distillation columns in the EDC and VCM purification trains contain halogenated hydrocarbons. Most of this waste is incinerated on site, but a portion is transferred to nonvinyl facilities for by-product recovery. Chlorinated solvents, such as perchloroethylene and trichloroethylene, are manufactured from these hydrocarbon byproducts that are recovered from the EDC/VCM process (25).

In the EDC/VCM process, the following wastes are listed hazardous wastes:

- K174: Wastewater treatment sludges from ethylene dichloride or vinyl chloride monomer production from the balanced process; and
- K175: Wastewater treatment sludges from vinyl chloride monomer production using an acetylene-based process (not discussed in this report).

6.8.2.3 Polyvinyl Chloride

Purified VCM is fed to a polymerization step to produce PVC. Polymerization processes that are used in the U.S. to produce PVC include:

- Suspension;
- Dispersion (emulsion);
- Bulk (mass); and
- Solution.

Since suspension polymerization accounts for approximately 87 percent of U.S. production (25), the remainder of this section focuses on that process.

In PVC production, polymerization is induced by adding free radical initiators. The initiators are soluble in VCM and typically include peresters, peroxy carbonates, peroxides, or azo compounds. The polymerization reaction, shown below, occurs in a batch reactor at temperatures ranging from 52° to 70°C (12).

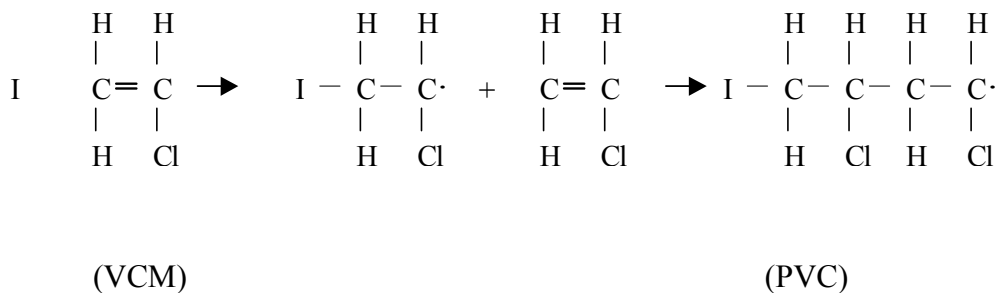

The reactor effluent contains residual VCM and a PVC slurry. Residual VCM might be in a gas or liquid phase or trapped in the PVC resin. Steam stripping can remove residual VCM which is recovered and recycled through the polymerization process. The PVC slurry is mixed with other PVC batches and sent through a dewatering process, where the polymer is separated from the process water. Water might be either recycled through the process or sent to wastewater treatment. As a last step, the PVC product is dried and screened to remove oversize and undersize particles. Figure 6-8 shows the PVC process.

6.8.3 Wastewater Sources

The chlor-alkali process involves three major purification pathways: chlorine purification, caustic purification, and hydrogen gas by-product purification. The wastewaters from these steps are combined prior to treatment. EPA did not identify any major sources of contact wastewater in the hydrogen gas purification steps. The caustic product from the mercury cell process is filtered to remove any residual mercury, and backwash from this filtration step is a source of wastewater. The chlorine gas stream exiting the mercury cell is cooled in an indirect contact heat exchanger followed by a wet demister. Dioxin might form as chlorine gas reacts with organic impurities in the process equipment (14). Thus, EPA believes the chlorine condensate wastewater stream is the main source of dioxin discharged from the chlor-alkali process.

The EDC/VCM process can produce dioxin during the oxychlorination reaction (14). This reaction can produce dioxin by combining hydrochloric acid as a source of chlorine, ethylene as the organic matter, temperatures over 200°C, the CuCl₂ catalyst, and oxygen as a reactant. EPA concludes that the most likely source of dioxins released to wastewater is the post-oxychlorination quenching step, when the gaseous product stream comes into contact with quench water.

6-59

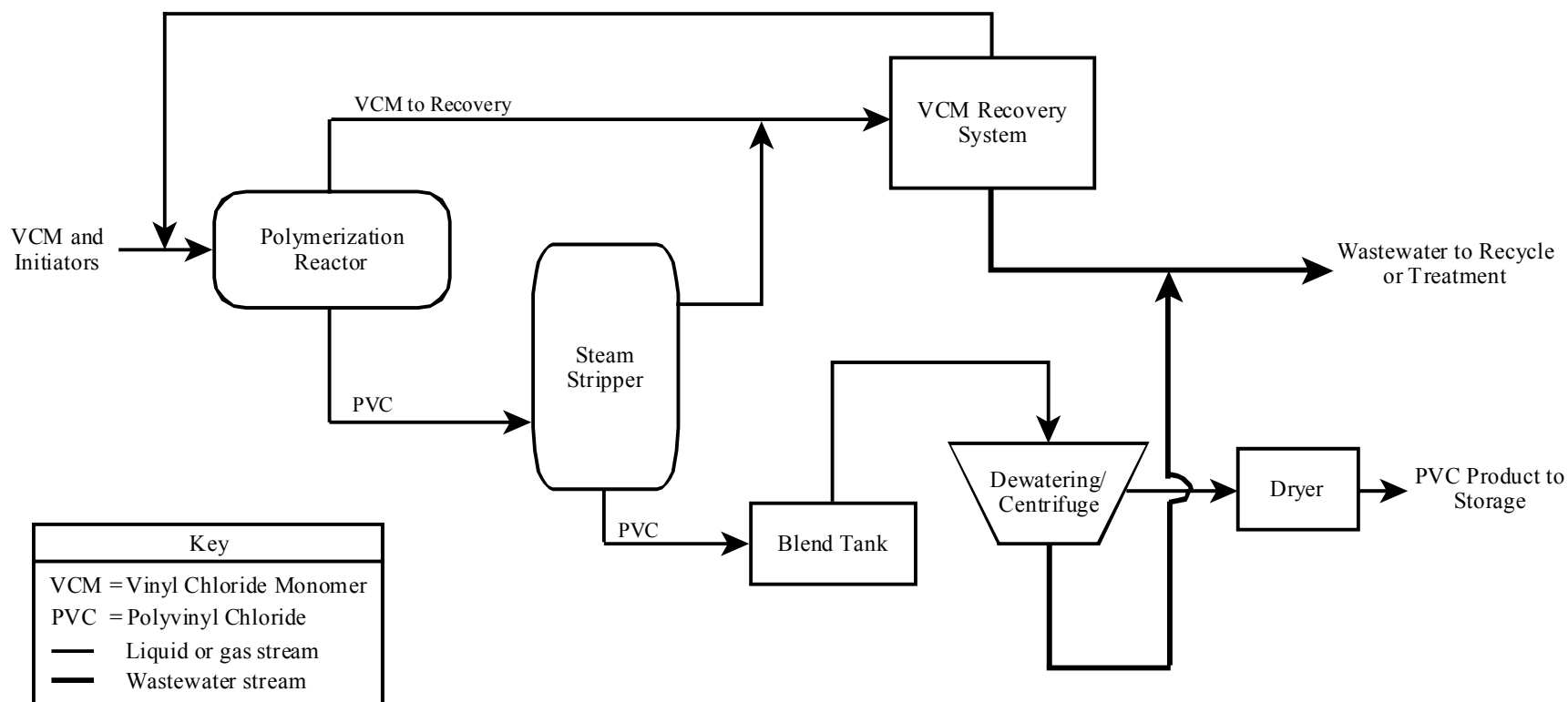

Figure 6-8. Process Flow Diagram for Suspension PVC Productions

Wastewater sources in the PVC process include the polymer dewatering operation and VCM recovery. The Vinyl Institute Dioxin Characterization program detected dioxin in wastewater from facilities that produce only PVC (see Section 6.8.4.2). Therefore, EPA has also identified the vinyl chloride polymerization step as another potential source of dioxin.

6.8.4 Pollutants of Concern

This section discusses the pollutants of concern for Focus Group 3. By far, dioxin is the most toxic pollutant in wastewater discharges from this group. Other toxic pollutants also discharged by Focus Group 3 that rank high in terms of toxic-weighted pounds, include sulfide, total residual chlorine, and hexachlorobenzene. Section 6.8.4.1 presents the pollutants of concern identified for each product group. Section 6.8.4.2 focuses on dioxin discharges.

6.8.4.1 Pollutants of Concern by Product Group

EPA reviewed pollutant discharges reported to TRI and PCS, and ranked pollutants based on TWPE estimates for the following groups of facilities:

- Stand-alone chlor-alkali manufacturers;
- Stand-alone manufacturers of EDC/VCM (may also produce PVC);
- Integrated chlor-alkali and EDC/VCM manufacturers (may also produce PVC); and
- Stand-alone manufacturers of PVC.

Tables 6-31 through 6-34 present the pollutants that rank high in terms of toxic-weighted pounds for each group.

EPA identified 36 facilities that produce chlorine using the chlor-alkali process. Of these facilities, 24 are not integrated with a vinyl chloride process. Table 6-31 presents the most toxic pollutant discharges reported by these facilities to TRI and PCS for 2000.

Table 6-31. Pollutants of Concern for 24 Stand-Alone Chlor-Alkali Manufacturers¹

	2000 Discharges		Percentage of Total TWPE for Source	Pollutant	Median per Facility Load (lb/yr)
	Pounds	TWPE			
TRI Data					
Dioxin and dioxin-like compounds	0.0086	98,618	89	3	0.0019
Mercury	69	8,078	7	5	12
Chlorine	3,578	1,742	2	2	1,789

Table 6-31 (Continued)

	2000 Discharges		Percentage of Total TWPE for Source	Pollutant	Median per Facility Load (lb/yr)
	Pounds	TWPE			
Sodium nitrite	3,000	1,120	1	1	NA
PCS Data					
Sulfide, Total as S	21,944	61,456	53	1	NA
Total residual chlorine	46,043	22,422	19	10	328
Mercury, Total as Hg	165	19,314	17	8	20
Chloride	166,221,615	4,047	4	3	39,583,393
Benzo(a)pyrene	0.90	3,855	3	1	NA
Copper, Total as Cu	3,705	2,322	2	7	76

Sources: *PCSLoads2000* and *TRIReleases2000*.

NA - A median load was not calculated because only one facility reported the pollutant.

¹May manufacture additional chemicals, but do not manufacture EDC, VCM, or PVC.

EPA identified 14 facilities that produce EDC/VCM. Of these facilities, two are not integrated with a chlor-alkali process. Table 6-32 presents the most toxic pollutant discharges reported by these nonintegrated facilities to TRI and PCS for 2000.

Table 6-32. Pollutants of Concern for Stand-Alone EDC/VCM Manufacturers (No Chlor Alkali)

Pollutant	2000 Discharges		Percentage of Total TWPE for Source	Number of Facilities Reporting Pollutant	Median per Facility Load (lb/yr)
	Pounds	TWPE			
TRI Data					
Dioxin and dioxin-like compounds	0.0013	2,477	89	1	NA
Chlorine	347	169	6	1	NA
PCS Data					
Copper, Total as Cu	51	32	71	1	NA
Chromium, Total as Cr	102	8	17	1	NA
Zinc, Total as Zn	108	5	11	1	NA

Sources: *PCSLoads2000* and *TRIReleases2000*.

NA - A median load was not calculated because only one facility reported the pollutant.

EPA identified 12 chlor-alkali/EDC/VCM integrated sites. Table 6-33 presents the most toxic pollutant discharges reported by these integrated facilities to TRI and PCS for 2000.

Table 6-33. Pollutants of Concern for Integrated Chlor-Alkali and Vinyl Facilities (Manufacturers of Chlor-Alkali and EDC/VCM, May Also Produce PVC)

Pollutant	2000 Discharges		Percentage of Total TWPE for Source	Number of Facilities Reporting Pollutant	Median per Facility Load (lb/yr)
	Pounds	TWPE			
TRI Data					
Dioxin and dioxin-like compounds	3.24	5,576,624	>99	9	0.051
Hexachlorobenzene	41	29,691	0.53	3	18
Chlorine	9,399	4,577	0.08	6	568
Copper compounds	3,345	2,097	0.04	4	163
PCS Data					
Total residual chlorine	43,608	21,237	46	9	723
Vinyl chloride	49,982	5,793	13	1	NA
Chromium, hexavalent	10,614	5,433	12	1	NA
Copper, total as Cu	5,060	3,172	7	11	228
Phenolics, total recoverable	82,460	2,309	5	1	NA
Mercury, total recoverable	12.2	1,425	3	1	NA
Mercury, total as Hg	11.7	1,368	3	3	1.9
Lead, total as Pb	582	1,303	3	4	81
Chloride	46,191,749	1,125	2	1	NA

Sources: *PCSLoads2000* and *TRIReleases2000*.

NA - A median load was not calculated because only one facility reported the pollutant.

EPA identified 18 facilities that operate a stand-alone PVC process. Table 6-34 presents the most toxic pollutant discharges reported by these facilities to TRI and PCS for 2000. None of the 18 stand-alone PVC manufacturers reported dioxin discharges to TRI in 2000. The Vinyl Institute, however, reported dioxin discharges to wastewater from PVC manufacturing (see Table 6-34).

Table 6-34. Pollutants of Concern for Stand-Alone Manufacturers of Polyvinyl Chloride

Pollutant	2000 Discharges		Percentage of Total TWPE for Source	Number of Facilities Reporting Pollutant	Median per Facility Load (lb/yr)
	Pounds	TWPE			
TRI Data					
Hydroquinone	71	90	58	1	NA
Acetaldehyde	7,509	15	10	2	3,755
Butyraldehyde	2,823	12	8	1	NA
Vinyl Chloride	94	11	7	8	9.5

Table 6-34 (Continued)

Pollutant	2000 Discharges		Percentage of Total TWPE for Source	Number of Facilities Reporting Pollutant	Median per Facility Load (lb/yr)
	Pounds	TWPE			
PCS Data					
Benzo(a)pyrene	0.396	1,696	70	1	NA
Mercury, total as Hg	1.80	211	9	1	NA
Benzo(b)fluoranthene	0.396	167	7	1	NA
Benzo(a)anthracene	0.396	71.7	3	1	NA
Copper, total as Cu	102	63.7	3	2	50.8

Sources: *PCSLoads2000* and *TRIRelases2000*.

NA - A median load was not calculated because only one facility reported the pollutant.

6.8.4.2 Dioxin as a Pollutant of Concern

Based on information in TRI and information obtained in industry studies, EPA estimates that OCPSF facilities discharged 22 million toxic weighted pounds of dioxin in 2000. This section discusses dioxin reporting and how TWPE were calculated for dioxin and presents the dioxin discharge data obtained from TRI, PCS, the Vinyl Institute, the CCC, EPA's Office of Solid Waste's study of chlorinated aliphatics manufacturing, and industry responses to EPA's 2004 request for dioxin data.

Dioxin Reporting

Dioxin reporting is discussed in detail in Section 4.2.4.2. The term "dioxins" refers to 17 polychlorinated dibenzo-p-dioxins (CDDs) and polychlorinated dibenzofurans (CDFs), referred to as dioxin congeners. The toxicity of the congeners varies greatly. In this report, the term "dioxins" is used to refer to all 17 of the 2,3,7,8-substituted CDDs and CDFs. EPA uses Toxic Equivalency Factors (TEFs) to simplify risk assessment and regulatory control of exposures to dioxins and still account for the relative toxicities of the 17 compounds. TEFs are order-of-magnitude estimates of the toxicity of a compound relative to 2,3,7,8-TCDD. EPA uses TEFs, along with the measured concentration of dioxin congeners, to calculate toxic equivalent (TEQ) concentrations.

For OCPSF Focus Group 3, EPA estimated TWPE for data from TRI, PCS, the CCC, and industry responses to EPA's 2004 information request. Data from these various sources are provided differently (TM17, TEQ, measured congener concentrations). Where possible for each data source, EPA calculated the TWPE using the EPA TWFs for the 17 dioxin congeners. EPA revised the TWFs for dioxins in 2004. The memorandum entitled Revisions to TWFs for Dioxin and its Congeners and Recalculated TWPEs for OCPSF and Petroleum Refining (available in the docket) presents the estimated TWPE for OCPSF facilities using the

revised TWFs. The following paragraphs discuss the method used to calculate dioxin TWPE using each data source. Later in the section, the resulting TWPE are presented.

For TRI, facilities report the total mass of the 17 dioxin and dioxin-like compounds released to the environment every year. This combined mass is referred to as TM-17. This reporting method does not account for the relative toxicities of the 17 compounds. However, reporting facilities are given the opportunity to report a facility-specific congener distribution. Note that the dioxin congener distribution for a facility is not media specific: it reflects the distribution for all air, water, and solid waste releases from the facility.

For facilities reporting a congener distribution to TRI, EPA used the reported distribution to estimate the mass of each congener in the facility's wastewater releases. EPA calculated dioxin TWPE by multiplying the estimated mass of each congener by its TWF. If no congener distribution was reported, EPA used an average congener distribution to calculate the mass of each congener. EPA calculated an average congener distribution for each of the four Focus Group 3 product groups: stand-alone chlor-alkali manufacturers, chlor-alkali/EDC/VCM manufacturers, stand-alone EDC/VCM manufacturers (may also produce PVC), and stand-alone PVC manufacturers.

Only one nonzero dioxin discharge load was included in PCS 2000 for an OCPSF facility. This was 0.00011 lbs of "chlorinated dibenzo-p-dioxins, effluent" for Dover Chemical Corporation. This facility manufactures chlorinated paraffins, surfactants, and lubricants (6), and EPA considers it as part of the "Other Organics" dioxin discharging facilities. To calculate the TWPE, EPA applied the average congener distribution derived from TRI data for the "Other Organics" product group to estimate the mass of each congener in the reported PCS discharge. EPA then applied the TWF of each congener to calculate the TWPE discharged by the Dover Chemical facility.

Data from the CCC are reported as grams TEQ, and no congener distribution is available. Because the grams TEQ unit represents the toxicity of all dioxin congeners detected relative to 2,3,7,8-TCDD (24), EPA used the TWF for 2,3,7,8-TCDD to calculate the TWPE. Section 4.2.4.2 of this TSD discusses TEQ, TEF, and TWPE for dioxin in more detail.

In response to EPA's 2004 information request, seven OCPSF Group 3 companies provided measured dioxin discharge data. These data included the concentration of each of the 17 dioxin congeners measured in wastewater samples and the flow of the sampled discharge. To calculate the TWPE associated with these reported discharges, EPA used the congener-specific TWF. No assumption on congener distribution was necessary.

TRI Dioxin Data

Table 6-35 presents the TRI-reported dioxin wastewater discharges for 2000 and 2001 and TWPE estimates for all OCPSF Focus Group 3 facilities: chlor-alkali, EDC, VCM, PVC manufacturers, and facilities that manufacture other organic chemicals. Some of these facilities reported zero dioxin discharge to TRI for 2001, but others reported increased dioxin discharges. Table 6-43 at the end of Section 6.8 lists data in conjunction with product type by facility.

Table 6-35. Dioxin Releases Reported by OCPSF Facilities to TRI for 2000 and 2001, Adjusted for POTW Removals

Company	Location	Discharge Status	2000		2001		2000 Basis for Estimate
			g TM17	TWPE	g TM17	TWPE	
Atofina Petrochemicals	La Porte, TX	Direct	0.079	1,161	0	0	O
Celanese Acetate	Narrows, VA	Direct	0.014	200	0	0	C, M, O
Condea Vista	Baltimore, MD	Direct	0.010	147	0	0	M, O
		Indirect	0.0034	50	0	0	M, O
Cytec Industries	Wallingford, CT	Direct	3.00	44,092	1.00	20,729	M, O
Dow Chemical	Freeport, TX	Direct	562.12	1,774,442	708	2,424,883	M, O
	Midland, MI	Direct	5.69	52,421	2	9,773	C, M, O
	Plaquemine, LA	Direct	745.86	1,553,042	512	1,103,903	M, O
DuPont Chamber Works	Deepwater, NJ	Direct	0.20	2,939	0	0	M, O
Formosa Plastics	Point Comfort, TX	Direct	0.61	1,563	0	0	M
	Baton Rouge, LA	Direct	0.0018	7.1	0	0	M, O
Geismar Vinyls (Borden)	Geismar, LA	Direct	0.61	2,477	0	0	C, M, O
Georgia Gulf	Plaquemine, LA	Direct	82.78	872,310	0	0	M, O
Occidental Chemical	Convent, LA	Direct	0.80	34,502	0	0	O, M
Occidental Chemical Corporation	Ingleside, TX	Direct	1.60	2,734	1	2,090	M
	Hahnville, LA	Direct	0.86	8,127	14	761,115	M, O
	Niagara Falls, NY	Direct	0.24	2,265	0	0	M, O
		Indirect	0.00054	5.1	0	0	M, O
Oxy Vinyls La Porte VCM Plant	La Porte, TX	Direct	2.33	41,958	1	36,022	M, O
PPG Industries, Inc.	Lake Charles, LA	Direct	74.79	1,296,066	42	683,841	M, O
	Natrium, WV	Direct	2.81	88,221	2	62,874	M

Table 6-35 (Continued)

Company	Location	Discharge Status	2000		2001		2000 Basis for Estimate
			g TM17	TWPE	g TM17	TWPE	
Sasol North America, Inc.	Westlake, LA	Direct	0.20	2,974	0	0	E, M, O
Velsicol Chemical Corporation	Memphis, TN	Indirect	4.14	16,872	5	24,901	DNR

Source: *TRIReleases2000* and 2001 National TRI Data.

Notes:

DNR indicates that the facility did not respond to this question in the 2000 TRI.

M— Estimate is based on monitoring data or measurements.

C— Estimate is based on mass balance calculations, such as calculation of the amount of wastes entering and leaving process equipment.

E— Estimate is based on published emission factors, such as those relating release quantity to through-put or equipment type (e.g., air emission factors).

O— Estimate is based on other approaches such as engineering calculations (e.g., estimating volatilization using published mathematical formulas) or best engineering judgment. This would include applying an estimated removal efficiency to a treatment, even if the composition of the waste before treatment was fully identified through monitoring data.

PCS Dioxin Data

Four facilities in Focus Group 3 are required by their NPDES permits to monitor their effluent for 2,3,7,8-TCDD, and one facility is required to monitor for chlorinated dibenzo-p-dioxins. According to *PCSLoads2000*, 2,3,7,8-TCDD was never detected in 2000. Table 6-36 presents the data obtained from the *PCSLoads2000* database for dioxin. Of the four facilities in Table 6-36, only Dow, Midland has data both in the PCS and TRI databases. For TRI, the Midland facility reported 5.69 grams total for all 17 dioxin congeners. For PCS, they reported no 2,3,7,8-TCDD detected.

Table 6-36. Dioxin Loads Reported by OCPSF Facilities to PCS for 2000

Facility	Parameter	lbs/yr	PCS TWPE
Formosa Plastics Corporation, La Porte, TX	2,3,7,8-TCDD	ND	ND
Dow Chemical Midland, MI	2,3,7,8-TCDD	ND	ND
Oxychem Lake Charles Plant	2,3,7,8-TCDD	ND	ND
Dover Chemical Corporation	2,3,7,8-TCDD	ND	ND
	Chlorinated Dibenzo-p-dioxins, Effluent	0.00011	418

Source: *PCSLoads2000*.

ND - Not detected.

Vinyl Institute Dioxin Data

In April and May of 1995, The Vinyl Institute conducted a Dioxin Characterization Program. Treated wastewater samples were taken from one integrated EDC/VCM/PVC site, three integrated EDC/VCM sites, and six PVC-only sites. Dioxins were detected in all four of the samples taken from integrated sites and in two of the samples taken from PVC-only sites. The Vinyl Institute developed wastewater “mean emission factors” to estimate how much dioxin is generated in wastewater from these manufacturing processes. The Vinyl Institute used production rates for EDC and PVC from 1995 to calculate a total release estimate. Table 6-37 summarizes the results presented in the final report.

Table 6-37. Wastewater Emission Factors and Estimated Releases for PVC-Only and EDC/VCM/PVC Manufacturing Facilities

Product Basis of Estimate	Mean Emission Factor ¹ (ug I-TEQ _{DF} / 1,000 metric tons product) ²	1995 Production (1,000 metric tons)	Estimated 1995 Dioxin Release (g I-TEQ _{DF}) ²	Estimated 1995 TWPE (Based on 1995 Production) ²
PVC	2.3 to 29	5,212	0.011 to 0.15	10,000 to 140,000
EDC	2.9 to 15	11,115	0.032 to 0.17	30 ,000 to 160,000

Source: Vinyl Institute Dioxin Characterization Program, 2001.

¹Mean emission factors were derived from treated wastewater samples.

²I-TEQ_{DF} means “International Toxic Equivalents, dioxin and furan.” The range of I-TEQ_{DF} values represent emission factors estimated based on ND = 0 and ND = ½ method detection limit (MDL). The MDLs for all congeners except octachlorodibenzo dioxin (OCDD) and octachlorodibenzo furan (OCDF) were 10 pg/L or less. MDLs for OCDD and OCDF were 50 pg/L or less.

Chlorine Chemistry Council (CCC) Dioxin Data

The CCC is a national trade association for manufacturers and users of chlorine and chlorine-related products. The CCC web page provides dioxin release data for major industrial producers and users of chlorine. The data represent releases of dioxin reported to TRI for 2000 in grams toxic-equivalents (TEQ) for each media release (air, water, and solid waste). In addition to providing more specifics on TRI data, the CCC and independent consultants performed site visits and further data verification at 16 facilities, to re-estimate dioxin releases to air, water, and land for the year 2000. Table 6-38 presents CCC data for 25 facilities, with the further-verified data for 16 facilities in bold.

Table 6-38. CCC Data for Dioxin Discharges from Facilities Manufacturing Chlorine or Chlorine-Related Products for 2000

Company	Location	Dioxin Water Release (g TEQ)	TWPE
Dow Chemical	Plaquemine, LA	7.71	7,165,568
Dow Chemical	Freeport, TX	6.91	6,425,964
Dow Chemical	Midland, MI	0.037	34,359
Formosa Plastics	Delaware City, DE	0	0
Formosa Plastics	Point Comfort, TX	0	0
Formosa Plastics Corporation Louisiana	Baton Rouge, LA	0	0
Geismar Vinyls	Geismar, LA	0	0
Georgia Gulf	Plaquemine, LA	0.023	21,177
Georgia Gulf Lake Charles LLC	Westlake, LA	0	0
Occidental Chemical	Convent, LA	0.00204	1,894
Occidental Chemical Company	Delaware City, DE	0.00013	120
Occidental Chemical Corporation and Oxymer	Ingleside, TX	0.181	168,434
Occidental Chemical Corporation	Hahnville, LA	1.08	1,003,972
Occidental Chemical Corporation	Mobile, AL	0.000036	34
Occidental Chemical Corporation	Niagara Falls, NY	0.01	9,296
Oxy Vinyls, Deer Park Chlor-alkali Plant	Deer Park, TX	0.54	501,774
Oxychem	Muscle Shoals, AL	0.000000087	0.0804
Oxychem	Castle Hayne, NC	0	0
OxyChem	Grand Island, NY ¹	0	0
OxyVinyls, Battleground Chlor-alkali Plant	LaPorte, TX	0.000483	449
Oxyvinyls, Deer Park VCM	Deer Park, TX	0.0308	28,649
Oxyvinyls, La Porte VCM Plant	La Porte, TX	0.00643	5,979
PPG Industries, Inc.	Lake Charles, LA	8.98	8,345,703
PPG Industries, Inc.	Natrium/New Martinsville, WV	0.193	178,978
Vulcan Chemical	Geismar, LA	0	0
	Wichita, KS	0	0

Sources: CCC web page, individual CCC reports.

¹The Oxychem Grand Island facility is not included in the OCPSF Dioxin Discharging Group because it is an R&D center. The facility was closed in December 2001.

Office of Solid Waste (OSW) Dioxin Data

In 1999, EPA proposed to list, but did not list, wastewaters from the production of chlorinated aliphatic hydrocarbons as hazardous waste (K173). EDC/VCM process wastewaters from distillation and purification processes, scrubbers, washings, phase separation, rainwater, and equipment washdowns would have been classified as K173. EPA did not promulgate regulations for these wastes; however, OSW analyzed untreated wastewater from eight facilities manufacturing EDC and VCM, testing the wastewater for toxicity characteristics (TC). Table 6-39 shows the dioxin congeners that were detected in the raw wastewater, demonstrating that EDC and/or VCM manufacturing generates dioxin in wastewater. Also, using the TEFs, EPA calculated that the toxicity of the mixture relative to 2,3,7,8-TCDD, was 1,537,000 pg (0.0015 mg) TEQ for each liter of wastewater generated (based on the maximum concentration detected).

Table 6-39. Dioxin Congeners Detected in Raw Wastewater from EDC/VCM Operations¹

Dioxin Congener Detected	Maximum Concentration ² (pg/L)	Toxic Equivalency Factor ³
1,2,3,4,6,7,8-HpCDD	880,000	0.01
1,2,3,4,6,7,8-HpCDF	43,000,000	0.01
1,2,3,4,7,8,9-HpCDF	12,000,000	0.01
1,2,3,4,7,8-HxCDD	52,000	0.1
1,2,3,6,7,8-HxCDD	91,000	0.1
1,2,3,7,8,9-HxCDD	110,000	0.1
1,2,3,4,7,8-HxCDF	5,300,000	0.1
1,2,3,6,7,8-HxCDF	1,200,000	0.1
1,2,3,7,8,9-HxCDF	1,200,000	0.1
2,3,4,6,7,8-HxCDF	430,000	0.1
2,3,4,7,8-PeCDF	230,000	0.5
2,3,7,8-TCDD	17,000	1
2,3,7,8-TCDF	82,000	0.1
Toxic Equivalency of Mixture, maximum (pg TEQ/L)		1,537,000

¹Source: EPA, *Best Demonstrated Available Technology (BDAT) Background Document for Chlorinated Aliphatics Production Wastes - K173, K174, K175*, OSW, July 1999 (16).

²Maximum concentration detected in wastewater from six facilities. EPA OSW sampled the influent to biological treatment from chlorinated aliphatics manufacturers, all of which manufacture EDC/VCM in addition to other chlorinated aliphatics. The samples were analyzed using EPA Method 1613.

³Toxic Equivalency Factors, TEFs, are a relative potency value that is based on the results of several in vivo and in vitro studies. TEFs are order of magnitude estimates of the toxicity of a compound relative to 2,3,7,8-TCDD. TEFs along with the measured concentration of dioxin congeners are used to calculate toxic equivalent (TEQ) concentrations (24).

Industry-Supplied Data

In May 2004, EPA requested process information and wastewater dioxin and flow data from eight companies that operate 20 facilities in Focus Group 3. As of August 11, EPA had received responses from eight companies (19 facilities). Thirteen of the 19 facilities provided analytical data on dioxin in treated effluent wastewater: some provided analytical data from a single sampling episode, and others provided multiple years of data. Nine facilities reported flows corresponding to the analytical data. Dioxin congeners were detected in the effluent wastewater of all thirteen facilities providing analytical data.

Nine facilities provided data on dioxin in untreated process wastewater. Four companies (six facilities) claimed their data as confidential business information (CBI), and EPA omitted data from presentations in this document where necessary, to protect CBI. See DCNs 00897 - 00899, 01027, and 01034-01037 for detailed facility data and DCN 01046 for EPA calculation methodology, all in Section 4.4 of the docket. Table 6-40 shows the range and median concentrations of dioxin in untreated and treated wastewater by process type, as well as the associated wastewater flows reported.

Table 6-40. Focus Group 3 Industry Analytical Data on Dioxin in Wastewater

Type of Wastewater	Number of Facilities with Data	Concentration, pg-TEQ/L		Range of Flows, MGD ¹
		Range	Median	
Raw Wastewater				
Chlorine gas condensates, prior to wastewater treatment	9	238 - 35,674	6,198	0.008 - 0.217
EDC quench water, prior to wastewater treatment	2	10,231 - 18,537	14,384	0 - 0.194
Treated Effluent Wastewater				
Treated process wastewater effluent, including chlor-alkali wastewater only	8	0.508 - 535	120	1.49 - 17.2
Treated process wastewater effluent, including chlor-alkali, EDC, VCM, and other organics operations	2	0.000104 - 110	55.2	11.6
Treated process wastewater effluent including EDC, VCM, and other organic operations	6	3.12 - 174	34.3	0.77 - 39.4
Treated process wastewater effluent, including PVC operations only	1	0.333	NA	NA

Source: Industry Responses to May 2004 EPA Data Request.

NA - when only one value is presented, the range and median are not provided.

¹Flows from four facilities were excluded from flow ranges to protect confidential business information. Also, some facilities providing flow data did not provide dioxin concentration data, and visa versa.

For the nine facilities that submitted analytical and flow data on dioxin in effluent wastewater, EPA calculated the grams of dioxin released per year and the associated TWPE. In all cases, EPA had actual congener concentrations and used the congener-specific TWF to calculate TWPE. For facilities with multiple years of data, EPA presents the mean annual dioxin discharge. See DCN 01046 in Section 4.4 of the docket for details on how EPA calculated the annual dioxin discharge. Table 6-41 presents the estimated dioxin TWPE by product group.

Table 6-41. Wastewater Dioxin Discharges from Focus Group 3 Based On Industry Data

Product Type	Number of Facilities with Data	Total Annual Dioxin Discharge	
		grams TEQ	TWPE ¹
Stand-alone manufacturers of chlor-alkali	2	1.76	285,000
Stand-alone manufacturers of EDC, VCM, and other organic operations	0	NR	NR
Integrated manufacturers of chlor-alkali, EDC, VCM, and other organics operations	7	10.1	2.1 million
Manufacturers of PVC only	0	NR	NR

Source: Industry Responses to May 2004 EPA Data Request.

NR - none reported.

¹TWPE were calculated using measured congener concentrations; therefore, the grams TEQ were not used to calculate the TWPE. For concentrations below detection limits, EPA assumed the concentration to be zero.

6.8.5 Comparison of Dioxin Release Data for OCPSF Focus Group 3

As discussed in Section 6.8.4, EPA has dioxin discharge data for OCPSF Focus Group 3 from the *TRIRelases2000*, CCC, and industry responses to EPA's May 2004 data request. TRI and CCC data represent 2000 dioxin discharges. In response to EPA's 2004 data request, industry provided data representing various years. EPA used the reported data to calculate an annual average. Table 6-42 compares the estimated grams and TWPE discharged per year for each of these data sources. In all three data sets, the integrated chlor-alkali and EDC/VCM product group accounts for more than 87 percent of the OCPSF Focus Group 3 dioxin discharges. The total TWPE estimated for OCPSF Focus Group 3 from dioxin ranges from 2.4 - 24 million TWPE (depending on the source). EPA notes that the number and identity of facilities contributing to the TWPE estimates from each data source in Table 6-42 are not the same.

Table 6-42. Comparison of Wastewater Dioxin Discharges from Focus Group 3

Product Type	TRI (2000 Data)			CCC (2000 Data)			Industry Responses ¹		
	Number of Facilities Reporting	g TM-17	TWPE	Number of Facilities Reporting	g TEQ	TWPE	Number of Facilities Reporting	g TEQ	TWPE ²
Stand-alone chlor-alkali	3	3.91	98,618	7	1.28	1.2 million	2	1.76	285,000
Stand-alone EDC/VCM	1	0.61	2,477	2	0	0	0	NC	NC
Integrated chlor-alkali and EDC/VCM	9	1,470	5.6 million	11	24	23 million	7	10.1	2.1 million
Stand-alone PVC	0	0	0	0	0	0	0	NC	NC
Total	13	1,480	5.7 million	21	26	24 million	9	12	2.4 million

Sources: *TRIRelases2000*, CCC, Industry Responses to May 2004 EPA Data Request.

NC - not calculated. The facilities providing concentration data did not provide flows; therefore, grams of dioxin discharged could not be estimated.

¹Some facilities provided one year of data (not necessarily for 2000), and others provided multiple years of data. See DCN 01046 in the docket for details on how EPA calculated annual discharge.

²TWPE were calculated using measured congener concentrations; therefore, the grams TEQ were not used to calculate the TWPE.

Table 6-43 lists all OCPSF Focus Group 3 facilities, grouped by product type:

- Stand-alone chlor-alkali manufacturers;
- Chlor-alkali and EDC/VCM manufacturers (may also manufacture PVC);
- Stand-alone EDC/VCM manufacturers (may also manufacture PVC); and
- Stand-alone PVC manufacturers.

To protect CBI, EPA can not present the facility-specific industry response data. However, Table 6-43 presents the reported TRI and CCC data (where available) by facility.

6.8.6 Wastewater Treatment in Place

Nine of the facilities in OCPSF Focus Group 3 reported wastewater treatment information to TRI. Of these, five reported having biological treatment for their dioxin-containing wastestream in conjunction with other treatment, such as solids removal.

From the CCC, EPA obtained general wastewater treatment in place data from three facilities: a chlor-alkali plant, an integrated chlor-alkali/EDC/VCM plant, and a stand-alone EDC/VCM plant. All of these facilities are direct dischargers and are discussed in the following subsections.

Table 6-43. List of Facilities Manufacturing Chlor Alkali, EDC, VCM, and PVC

Site Name	Location	Discharge Type	Product(s) Manufactured						Dioxin and Dioxin-Like Compounds Reported for 2000				Comments	
			Chlor Alkali (Na and Cl)	Potassium and Chlorine (K and Cl)	Recover Chlorine by Other Means	EDC	VCM	PVC	TRI		CCC			
									g/yr	TWPE/yr	g/yr TEQ	TWPE/yr		
Stand-Alone Chlor-Alkali Manufacturers														
Ashta	Ashtabula, OH			Mercury cell										Additional products: plastics, coatings, polyurethanes and industrial chemicals
Bayer	Baytown, TX		Membrane & HCl cells											
DuPont	Niagara Falls, NY				Downs sodium									
GE Plastics	Burkville, AL		Diaphragm & membrane cells											
GE Plastics	Mount Vernon, IN		Diaphragm cell											
Kuehne	Kearny, NJ		Membrane cell											Chlorine Institute lists location as Delaware City, DE, but environmental data only exist for Kearny, NJ.
Occidental Chemical Company	Delaware City, DE		Mercury cell								0.00013	120		
Occidental Chemical Corporation	Hahnville, LA	Direct	Diaphragm & membrane cell						0.86	8,127	1.08	1,003,972		Location also noted as Taft on CCC web site.
Occidental Chemical Corporation	Mobile, AL	Direct	Membrane cell	Membrane cell							0.0000364	34		
Occidental Chemical Corporation	Niagara Falls, NY	Direct and Indirect (dioxin reported as indirect)	Diaphragm cell						0.24	2,270	0.01	9,296		
Olin	Augusta, GA		Mercury cell											
Olin	Charleston, TN		Mercury cell											

Table 6-43 (Continued)

Site Name	Location	Discharge Type	Product(s) Manufactured						Dioxin and Dioxin-Like Compounds Reported for 2000				Comments
			Chlor Alkali (Na and Cl)	Potassium and Chlorine (K and Cl)	Recover Chlorine by Other Means	EDC	VCM	PVC	TRI		CCC		
									g/yr	TWPE/yr	g/yr TEQ	TWPE/yr	
Olin	McIntosh, AL		Diaphragm cell										Co-located with the jointly ventured Olin/PolyOne McIntosh plant.
Sunbelt/Olin	McIntosh, AL												Co-located with the jointly ventured Olin/PolyOne McIntosh plant.
Olin	Niagara Falls, NY		Membrane cell										
Oxychem	Muscle Shoals, AL		Mercury cell	Mercury cell					0.0000000865		0.0804		
Pioneer	Henderson, NV		Diaphragm cell										
Pioneer	St. Gabriel, LA		Mercury cell										
Pioneer: IDLED 2002	Tacoma, WA		Diaphragm & membrane cell										Idled 02/02 according to Chlorine Institute.
PPG Industries, Inc.	Natrium/New Martinsville, WV	Direct	Diaphragm & mercury cell						2.81	88,221	0.193	178,978	
Vulcan	Port Edwards, WI		Mercury cell										
Vulcan	Wichita, KS	Direct	Diaphragm & membrane cells								0	0	
Georgia Pacific	Green Bay, WI		Diaphragm cell										
Georgia Pacific	Muskogee, OK		Membrane cell										
Georgia Pacific	Rincon, GA		Membrane cell										
Chlor-Alkali and EDC/VCM Manufacturers (May Also Manufacture PVC)													
Dow	Plaquemine, LA	Direct	Diaphragm cell			Yes	Yes		747	1,553,042	7.71	7,165,568	
Dow	Freeport, TX	Direct	Diaphragm & membrane cells		Magnesium	Yes	Yes		563	1,774,442	6.91	6,425,964	Dow Chemical at Oyster Creek is considered part of the Freeport Plant.
Georgia Gulf	Plaquemine, LA	Direct	Diaphragm cell			Yes	Yes	Yes	82.87	872,310	0.0228	21,177	
PPG	Lake Charles, LA	Direct	Diaphragm & mercury cells			Yes	Yes		75	1,296,066	8.98	8,345,703	

6-74

Table 6-43 (Continued)

Site Name	Location	Discharge Type	Product(s) Manufactured						Dioxin and Dioxin-Like Compounds Reported for 2000				Comments
			Chlor Alkali (Na and Cl)	Potassium and Chlorine (K and Cl)	Recover Chlorine by Other Means	EDC	VCM	PVC	TRI		CCC		
									g/yr	TWPE/yr	g/yr TEQ	TWPE/yr	
Occidental Chemical Corporation and Oxymar	Ingleside, TX	Direct	Diaphragm cell			Yes	Yes		1.60	2,734	0.181	168,434	Occidental and Oxymar are the same plant located in Gregory, TX, (Corpus Christi or Ingleside, TX - all listings are the same location). EDC Plant temporarily idled since June 2001.
Occidental Chemical	Convent, LA	Direct	Diaphragm cell			Yes			0.80	34,502	0.002	1,896	
Formosa Plastics	Point Comfort, TX	Direct	Membrane cell			Yes	Yes	Y Yes	0.61	1,563	0	0	
Formosa Plastics Corporation Louisiana	Baton Rouge, LA	Direct	Diaphragm cell			Yes	Yes	Yes	0.0018	7	0	0	
Oxy Vinyls, La Porte VCM Plant	La Porte, TX	Direct				Yes	Yes		2.33	41,958	0.00643	5,979	Plants are co-located
Oxy Vinyls, Battleground Chlor Alkali Plant			Diaphragm cell								0.000483	449	
Oxy Vinyls, Deer Park PVC Plant	Deer Park, TX	No reported discharge						Yes					Plants are co-located. Chlor-alkali plant idled since December 27, 2001.
Oxy Vinyls, Deer Park VCM		Direct	Yes			Yes	Yes			0.0308	28,649		
Oxy Vinyls, Deer Park Chlor Alkali Plant											0.540	501,774	
Vulcan	Geismar, LA	Direct	Diaphragm cell			Yes					0	0	
Vulcan/Mitsui			Membrane cell										
Westlake Monomers	Calvert City, KY	Direct	Membrane cell			Yes	Yes						Formerly a Goodrich Facility.

Table 6-43 (Continued)

Site Name	Location	Discharge Type	Product(s) Manufactured						Dioxin and Dioxin-Like Compounds Reported for 2000				Comments
			Chlor Alkali (Na and Cl)	Potassium and Chlorine (K and Cl)	Recover Chlorine by Other Means	EDC	VCM	PVC	TRI		CCC		
									g/yr	TWPE/yr	g/yr TEQ	TWPE/yr	
Stand-Alone EDC/VCM Manufacturers (May Also Manufacture PVC)													
Borden Chemical (Geismar Vinyls)	Geismar, LA	Direct				Yes	Yes	Yes	0.61	2,477	0	0	Geismar Vinyls purchased Borden's EDC/VCM/PVC plant in 2003.
Georgia Gulf, Lake Charles LLC	Westlake, LA	Transfer to Sasol N.A.				Yes	Yes				0	0	Also known as Condea Vista Chemical Corporation and Vista Chemical. Location sometimes listed as Lake Charles. Discharges to Sasol N.A.
Stand-Alone PVC Manufacturers													
Certaiteed Corporation	Westlake, LA	Direct						Yes					
Colorite Specialty Resins	Burlington, NJ	Direct						Yes					Same plant as Geon and Polyone in Burlington.
Dow Chemical, Texas City Plant	Texas City, TX	Indirect						Yes					Formerly Union Carbide - merged with Dow in 2001.
Formosa Plastics	Delaware City, DE	No reported discharge						Yes			0	0	Also known as Georgia Gulf.
Formosa Plastics	Illioopolis, IL	Direct						Yes					Purchased from Borden in 2002.
Georgia Gulf	Aberdeen, MS	Indirect						Yes					
Georgia Gulf Chemicals & Vinyls LLC	Oklahoma City, OK	No reported discharge						Yes					
Occidental Chemical Corporation	Pottstown, PA	Indirect						Yes					
Oxy Vinyls	Louisville, KY	No reported discharge						Yes					Formerly PolyOne.
Oxy Vinyls	Pedricktown, NJ	Direct						Yes					Formerly PolyOne.

Table 6-43 (Continued)

Site Name	Location	Discharge Type	Product(s) Manufactured						Dioxin and Dioxin-Like Compounds Reported for 2000				Comments	
			Chlor Alkali (Na and Cl)	Potassium and Chlorine (K and Cl)	Recover Chlorine by Other Means	EDC	VCM	PVC	TRI		CCC			
									g/yr	TWPE/yr	g/yr TEQ	TWPE/yr		
Oxy Vinyls L.P., Pasadena PVC Plant	Pasadena, TX	Direct						Yes						
Polyone Corporation	Burlington, NJ	No reported discharge						Yes						Vinyl compounding site - closed in 2002.
Polyone Corporation	Henry, IL	No reported discharge						Yes						Also known as Geon.
Shin tech Inc.	Addis, LA	Direct						Yes						Purchased from Borden in 2002.
Shintech Inc.	Freeport, TX	Direct						Yes						
Vygen	Ashtabula, OH	No reported discharge						Yes						Appears to be closed as of 1993.
Westlake PVC Corporation	Calvert City, KY	Direct						Yes						
Westlake PVC Corporation	Pensacola, FL	No reported discharge						Yes						Appears to be closed.

Sources: *TRI Releases 2000*; CCC; internet searches; Vinyl Institute's The Vinyl Institute Report Dioxin Characterization Program, May 15, 2001; EPA, Memorandum: Review of Total TWPE Loads for Dioxin/Dioxin-Like Compounds for the Inorganic Chemicals Manufacturing Category, September 18, 2003; and personal correspondence.

Cl - Chlorine

K - Potassium

6.8.6.1 Chlor-Alkali

The PPG plant in Natrium, WV is an example of a chlor-alkali manufacturing site that does not produce vinyl chloride. The plant produces chlorine and caustic using diaphragm cell and mercury cell technologies. Treatment of the wastewaters from the diaphragm cell process includes neutralization and chemical precipitation. Wastewaters from the mercury cell process are treated using chemical precipitation followed by polishing with activated carbon for mercury removal. (See DCN 01035 in the docket).

6.8.6.2 Integrated Chlor-Alkali/EDC/VCM

Dow Chemical in Freeport, TX is an example of an integrated chemical plant that produces chlorine and caustic using diaphragm and membrane cells, ethylene, EDC using two oxychlorination units, VCM, chlorinated solvents, and other chemical products. The wastewater treatment facility operates a physical/chemical and biological wastewater treatment system with effluent filtration for combined process wastewaters from chlor-alkali, EDC/VCM, and chlor-hydrin processes. As of 2001, VCM process wastewater is filtered after steam stripping and prior to biological treatment. Wastewater treatment plant sludges, spent oxychlorination EDC catalyst, asbestos from chlor-alkali diaphragm cell operations, and other solid wastes are disposed of in an on-site landfill. (See DCN 00899 in the docket).

6.8.6.3 EDC/VCM

The OxyVinyls LaPorte VCM plant is an example of a stand-alone EDC/VCM plant. In 2000, the facility produced EDC using a combination of direct chlorination and oxychlorination. The facility shut down its high temperature direct chlorination EDC process in April 2002. EDC/VCM process wastewaters are treated using steam stripping followed by biological treatment. Wastewater treatment plant sludges and spent oxychlorination EDC catalyst are disposed of off-site in secure landfills. (See DCN 01034 in the docket).

6.8.7 Industry Trends

This section discusses the trends that EPA observed in the industry based on available data. Section 8.7.1 discusses the trend of dioxin discharges from the industry, and Section 8.7.2 discusses the production trend of the chlorine industry.

6.8.7.1 Dioxin Discharge Trends

The CCC reviewed information from select CCC member plants to develop year 2000 release estimates of dioxin for use in EPA's dioxin reassessment¹. If plants had made significant changes, the CCC also presented release estimates for 2002 as indicators of future

¹EPA is currently collecting data as part of the dioxin reassessment effort, which updates the 1995 Dioxin Inventory. For more information, see <http://cfpub.epa.gov/ncea/cfm/dioxin.cfm?ActType=default>.

releases. Table 6-44 compares the CCC data from 2000 and 2002. The data show an overall reduction of approximately 16 grams TEQ (15,000,000 lb-eq) of dioxin in water releases from 2000 to 2002.

Table 6-44. Vinyl Manufacturing and Chlor-Alkali Facility Dioxins in Wastewater

Facility	Location	2000 g TEQ	2002 g TEQ	Percent Change
PPG Industries	Lake Charles, LA	8.98	0.653	-93
Dow Chemical Co.	Plaquemine, LA	7.71	2.74	-64
Dow Chemical Co.	Freeport, TX	6.91	3.76	-46
PPG Industries	Natrium, WV	0.193	NC	NA
Occidental Chemical Corporation	Ingleside, TX	0.181	0.187	3
Dow Chemical Co.	Midland, MI	0.037	NC	NA
Occidental Chemical Corporation	Deer Park, TX	0.0308	NC	NA
Georgia Gulf	Plaquemine, LA	0.0228	0.024	4
Occidental Chemical Corporation	LaPorte, TX	0.00643	NC	NA
Occidental Chemical Corporation	Convent, LA	0.00204	NC	NA
Occidental Chemical Corporation	Mobile, AL	0.0000364	NC	NA

Source: CCC Data provided to Dwain Winters, April 2004. All concentrations reported as grams TEQ.

NA - Percent change could not be calculated because comparable data were not available.

NC - 2002 release estimated were not calculated because they are not expected to be significantly different from 2000 release estimates.

CCC observed the largest reductions at the PPG plant in Lake Charles, LA and the Dow Chemical facilities in Freeport, TX and Plaquemine, LA. In the CCC report, the PPG Lake Charles plant attributes their 93-percent reduction of dioxin water releases to environmental control projects implemented since 2000 (see DCN 00899 in the docket). PPG expects further reductions of dioxin releases as the plant continues to implement new environmental projects.

In 1995, Dow Chemical announced its plans to implement a program to reduce global dioxin releases from its manufacturing plants to air and water by 90 percent by the year 2005. So far, reductions of approximately 75 percent have been achieved across all media (7). The Dow Freeport, TX plant upgraded its oxychlorination EDC technology in 2001. Both Dow facilities (Freeport, TX and Lake Charles, LA) installed filtering equipment for partially treated EDC/VCM wastewaters. This new treatment, and other process improvements made in 2001 and 2002, account for the reduction of dioxin water releases (see DCN 00899). Note that although the TM-17 dioxin value for Dow Freeport increased from 2000 to 2001 (see Table 6-35), the dioxin release for 2002 is less than 2000, based on site-verified CCC data.

6.8.7.2 Chlorine Industry Trends

End uses of chlorine manufactured in the U.S. include chemical production, vinyl products, water disinfection, and the pulp and paper industry. Approximately 40 percent of the chlorine manufactured in the U.S. is used to produce EDC (8).

The Chlorine Institute tracks the U.S. domestic production of chlorine. Table 6-45 lists the production for the last 10 years. In general, production increased from 1993 to 2000. In 2001, however, production slowed because companies closed or idled chlor-alkali plants. Since 2001, seven chlor-alkali plants have either been closed or idled, which accounts for approximately 10 percent of the U.S. production (8). Demand for chlorine has decreased over the last decade. A large portion of the decrease is attributed to the recycle of HCl for the oxychlorination process in EDC production. Companies have found additional sources of by-product HCl, which lowered the chlorine requirements for EDC production. In addition, chlorine use in the pulp and paper industry has decreased over the past ten years in response to environmental pressures (8).

Table 6-45. Chlorine Production in the United States

Year	Annual Production, tons/year
2002	12,666,629
2001	12,604,865
2000	14,057,698
1999	13,807,739
1998	13,532,559
1997	13,685,360
1996	13,168,384
1995	12,990,066
1994	12,612,760
1993	11,983,420

Source: Chlorine Institute, 2003.

6.8.8 Conclusions

Findings of EPA's detailed study of OCPSF Focus Group 3, dioxin dischargers, are summarized below.

- The term "dioxins," or polychlorinated dibenzo-p-dioxins (CDDs) and polychlorinated dibenzofurans (CDFs), refers to the 17 individual compounds (congeners) with chlorine substitution of hydrogen atoms at the 2, 3, 7, and 8 positions on the benzene rings.

- Dioxins are persistent, bioaccumulative and toxic (PBT) pollutants, associated with a range of adverse human health effects, including cancer. EPA's human health-based water quality criterion (water + organism) for the most toxic dioxin isomer, 2,3,7,8-tetrachlorodibenzo-p-dioxin (dioxin), is 0.005 pg/L (5×10^{-9} ug/L) (24). Due to their toxicity and ability to bioaccumulate, the various congeners of dioxin have high toxic weighting factors (TWFs). Consequently, even small mass amounts of dioxin discharges translate into high toxic weighted pounds equivalents (TWPEs).
- OCPSF Focus Group 3 includes facilities that manufacture chlor-alkali, EDC/VCM, and/or PVC. Some integrated facilities manufacture several of these products.
- Using data reported to TRI for 2000, EPA estimated that dioxin contributes 92 percent of the TWPE for stand-alone chlor-alkali manufacturers, stand-alone EDC/VCM manufacturers, and integrated chlor-alkali and vinyl facilities. None of the 18 stand-alone PVC manufacturers reported dioxin discharges to TRI for 2000.
- For OCPSF Focus Group 3, EPA has facility-specific dioxin water discharge data from the following data sources: *TRIRelases2000*, the CCC, and industry responses to EPA's 2004 information request.
- For the TRI, U.S. industrial facilities were first required to report dioxin releases for 2000, and facilities report the total mass of the 17 congeners released and the congener distribution. For TRI data, EPA calculated TWPE of dioxins released using facility-reported congener distributions. If a facility did not report a congener distribution, EPA used the product group-specific average distribution to calculate the mass of each congener released. **Using TWFs for each congener and TRI data as reported (accounting for POTW removals), EPA estimated that 14 OCPSF Focus Group 3 facilities discharged 1,500 grams TM-17 of dioxin (5.7 million TWPE).**
- In 2000, none of the facilities in Focus Group 3 are required by their NPDES permits to monitor their effluent for 2,3,7,8-TCDD or dioxins as a group. However, EPA is aware of one facility, Dow Freeport, that has a 2003 permit monitoring requirement for dioxins as 2,3,7,8-TCDD TEQ. Therefore, no PCS data were available for facilities in Group 3 at the time of this report.
- For 2000 CCC data, which generally included data verification, facilities reported the total grams TEQ released, which represents the total grams relative to the toxicity of 2,3,7,8-TCDD. No congener distribution is

available. Because the grams TEQ reflects the toxicity of all dioxin congeners detected relative to 2,3,7,8-TCDD, EPA used the TWF for 2,3,7,8-TCDD to calculate the TWPE. **EPA estimated that 21 OCPSF Group 3 facilities discharged 26 grams TEQ of dioxin (24 million TWPE).**

- The CCC also provided 2002 data for some facilities. Out of 11 facilities with 2000 data, five provided 2002 data. Comparing 2000 with 2002 data, three facilities had significant reductions in dioxin, two had slight increases, and six did not provide 2002 data because they did not expect that the numbers would be different from 2000. **The 2002 CCC data show an overall reduction of approximately 16 grams TEQ of dioxin (15 million TWPE). Accounting for these reductions, approximately 10 grams TEQ (9 million TWPE) remain.**
- For industry responses to EPA's 2004 information request, 18 facilities reported concentrations of dioxin detected in the wastewater by congener, and usually the associated flow. To calculate the dioxin TWPE discharge from facilities, EPA used the congener-specific TWF. No assumption on congener distribution was necessary. If facilities provided concentration data over multiple years (e.g., 1996 - 2000), EPA averaged the reported concentrations to calculate the amount of dioxin released per year. **EPA estimated that nine OCPSF Group 3 facilities discharged 11.9 grams TEQ of dioxin (2.4 million TWPE).**
- EPA also obtained discharge data from the Vinyl Institute, which performed a study of dioxin releases from EDC, VCM, and PVC manufacturing. The Vinyl Institute detected dioxin in all four wastewater samples from facilities with EDC/VCM manufacturing (one facility also manufactured PVC). The Vinyl Institute detected dioxin in two of six wastewater samples from PVC manufacturers. The Vinyl Institute estimated that for 1995, 0.011 - 0.15 grams of dioxin (10,000 - 140,000 TWPE) were released from PVC manufacturers and 0.032 - 0.17 grams of dioxin (30,000 to 160,000 TWPE) were released from EDC/VCM manufacturers.
- EPA's OSW also studied dioxin concentrations in raw wastewater from EDC/VCM processes and detected 13 of 17 dioxin congeners. OSW detected concentrations of 2,3,7,8-TCDD at up to 17,000 pg/L and 1,2,3,4,6,7,8-HpCDF at up to 43,000,000 pg/L in raw wastewater.
- Industry response to EPA's 2004 information request included measured concentrations of dioxin in process wastewater. Industry data indicate dioxin, including 2,3,7,8-TCDD, is detected in chlorine gas condensates from the chlor-alkali manufacturing process and in EDC quench water.

Industry data indicate that dioxin is not generated in the VCM and PVC manufacturing processes. **Of the 13 OCPSF Group 3 facilities that provided analytical effluent data, dioxin congeners were detected in the final effluent of all 13 facilities.**

- OCPSF Group 3, by far, contributes the most significant TWPE compared with other industry groups. For example, the OCPSF Group 3 TWPE from just dioxin is 24 million TWPE using CCC data (5.7 million TWPE using TRI data). The total TWPE from all other industries combined, for all pollutants, is just 14.4 million TWPE.

Based on information from the detailed review, EPA concludes that dioxins are generated during manufacture of chlor-alkali and EDC. EPA further concludes that dioxins are discharged in treated effluent of facilities that manufacture chlorine by the chlor-alkali process, EDC, and/or VCM. Given the toxicity of dioxins and the tendency for bioaccumulation, EPA concludes that dioxin discharges from the manufacture of chlor-alkali and EDC warrant further study.

6.9 Control of Dioxin in Wastewater

This section discusses the wastewater treatment options identified by EPA to minimize dioxin in wastewater. Section 6.9.1 discusses new treatment technologies, and Section 6.9.2 discusses the cost data available on these technologies.

6.9.1 Treatment Technologies for Control of Dioxin in Wastewater

EPA identified technologies to minimize the amount of dioxin in wastewater from data collected in previous effluent guidelines, vendors, and industry. These technologies include pollution prevention, in-process wastewater treatment, and end-of-pipe add-on wastewater treatment. Section 6.9.1.1 discusses pollution prevention techniques. Section 6.9.1.2 discusses in-process wastewater treatment technologies. Section 6.9.1.3 discusses end-of-pipe add-on wastewater treatment technologies.

6.9.1.1 Pollution Prevention

EPA requested data on pollution prevention from eight companies that manufacture chlor alkali, EDC, and VCM. The eight companies responded, providing analytical and treatment data; however, no facilities identified pollution prevention methods. For example, no facility identified feedstock substitution or process modification to prevent dioxin formation.

6.9.1.2 In-Process Wastewater Treatment

As discussed in Section 6.8.5, most of the dioxin dischargers, including those producing chlor alkali, EDC, VCM, and/or PVC, have end-of-pipe biological treatment in place. Most of the chlor-alkali and vinyl manufacturing facilities produce many chemicals, and

wastewater from the entire plant is typically commingled prior to biological treatment. End-of-pipe flows are large, ranging from 0.36 to 40 MGD, and segregating dioxin-containing wastewater streams allows for targeted dioxin removal.

Facilities can control dioxin-containing segregated wastewater streams by removing solids or the using granular activated carbon. For the chlor-alkali and vinyl manufacturing industry, EPA identified that the following wastewater streams that might contain dioxin (see industry responses to EPA's 2004 information request, DCNs 00897 - 00899, 01027, and 01034-01037 in the docket):

- Chlorinated gas condensates;
- EDC quench water; and
- EDC spent catalyst regeneration water.

Dioxin is hydrophobic and adheres to solids; therefore removing solids or sludges is an effective technique to remove dioxin from wastewater (20, 24). (Sludge from wastewater treatment of EDC/VCM wastewater is K174 hazardous waste (15)). Some solids removal technologies that could be added in process include sand filtration, multimedia filtration, ultrafiltration, and clarification. For example, a facility could pass chlorine gas condensates through filter cartridges prior to commingling them with other wastewater.

Similarly, granular activated carbon removes dioxin from wastewater. One facility reported passing chlorine gas condensates through granular activated carbon units prior to biological treatment, removing an average greater than 90 percent of the dioxin in the chlorine gas condensates (see DCN 01035 in Section 4.4 of the docket). Other facilities reported solids removal technologies to remove dioxin prior to end-of-pipe treatment as well.

6.9.1.3 End-of-Pipe Wastewater Treatment

EPA also considered what add-on end-of-pipe treatment technologies would remove dioxin. Solids removal and granular activated carbon would remove dioxin, but the large volume of end-of-pipe wastewater may make their application cost prohibitive. Improved end-of-pipe treatment could include: PACT® treatment (adding of powdered activated carbon to activated sludge systems) or optimized (chemically assisted) clarification.

6.9.2 **Summary of Available Treatment Cost Data and Justification for Not Estimating Costs**

To estimate the cost of implementing an in-process or end-of-pipe wastewater treatment technology, flow and pollutant concentration data are needed. For example, to size a sand filter for a waste stream, the solids content must be known. To design a granular activated carbon unit (either bed or canister), flow and chemistry of the influent wastewater determine the size and number of units needed. EPA requested data on flow and chemistry of in-process and end-of-pipe wastewater from eight companies with chlor-alkali, EDC, VCM, and PVC operations. EPA received responses with flow and chemistry data from six companies in July,

one month prior to publication of this report. Therefore, at the time of the writing of this report, EPA had insufficient data for estimating costs.

6.10 Chemical Formulators, Packagers, and Repackers

In conjunction with the detailed review of the OCPSF category, EPA also analyzed data from facilities that formulate, package, and repackage chemicals into products for end use or for further processing but are not covered by existing point source categories, to determine if new subcategories of OCPSF should be identified for further study.

This section discusses a potential new subcategory referred to as Chemical Formulating, Packaging, and Repackaging (CFPR). CFPR operations are those that mix or blend chemicals without intended chemical reaction, and those that package or repackage chemicals into products for end use or further packaging. This section discusses EPA's findings on this potential subcategory in the following subsections:

- Section 6.10.1 presents the facilities identified as having CFPR operations;
- Section 6.10.2 describes the processes and sources of wastewaters at CFPR operations;
- Section 6.10.3 lists the pollutants of concern identified based on available data;
- Section 6.10.4 describes the wastewater treatment at CFPR facilities; and
- Section 6.10.5 explains EPA's next action for this group of facilities.

6.10.1 CFPR Industry Description

In the *1997 EPA Chemical Formulating, Packaging, and Repackaging Industry Special Study (1997 CFPR Study)*, EPA identified the following industries within major SIC group 28 (Chemical and Allied Products) as CFPR industries:

- SIC 2841 - Soap and Detergents, Except Specialty Cleaners;
- SIC 2842 - Specialty Cleaning, Polishing and Sanitation Preparation;
- SIC 2844 - Perfumes, Cosmetics, and Other Toilet Preparations;
- SIC 2851 - Paints, Varnishes, Lacquers, Enamels, and Allied Products;
- SIC 2891 - Adhesives and Sealants;
- SIC 2893 - Printing Ink; and
- SIC 2899 - Chemicals and Chemical Preparations, not elsewhere classified.

EPA conducted this study to determine whether it should develop ELGs for the CFPR industry, or some sectors of the industry. The study fulfilled EPA's obligations under section 304(m) of the CWA.

Three of the SIC codes included in the *1997 CFPR Study* contain facilities that are covered by existing effluent limitation guidelines:

- SIC 2841 - 40 CFR Part 417, Soap and Detergent Manufacturing;
- SIC 2851 - 40 CFR Part 446, Paint Formulating; and
- SIC 2893 - 40 CFR Part 447, Ink Formulating.

EPA included SIC codes 2841, 2851, and 2893 in the *1997 CFPR Study* because some facilities reporting these SIC codes are not specifically regulated under Parts 417, 446, or 447 and could be considered part of the CFPR industry. Due to data limitations, EPA could not differentiate facilities that were included in existing point source categories and facilities that were part of CFPR. Therefore, EPA included all facilities reporting SIC codes 2841, 2851, and 2893 in the *1997 CFPR Study*. However, EPA did not consider facilities in SIC codes 2841, 2851, and 2893 in this detailed review, which applies to operations being considered only as a new subcategory of OCPSF. Instead, EPA is including these SIC codes in the review of Parts 417, 446, and 447. EPA considered any operations in these SIC codes but outside of the current applicability of these categories as potential new subcategories of the respective category. This detailed review of CFPR facilities covers only facilities reporting SIC codes 2842, 2844, 2891, or 2899. See the documents in the docket entitled, "Toxic Weighted Pound Equivalent (TWPE) Loads by Facility and By Pollutant for SIC Code 2841, Soaps and Other Detergents, Except Specialty Cleaners, July 21, 2004"; TWPE Loads By Facility and By Pollutant for SIC Code 2851, Paints, Varnishes, Lacquers, Enamels, and Allied Products, July 14, 2004"; and "TWPE Loads By Facility and By Pollutant for SIC Code 2893, Printing Ink, July 14, 2004."

EPA identified facilities included in the potential new CFPR subcategory of the OCPSF ELG based on their primary SIC codes, as reported to TRI and PCS. Therefore, data limitations of the reported SIC codes are particularly relevant to this set of facilities. The diversity of the chemical products manufactured and operations used at these facilities makes it often difficult to characterize a facility's discharges under a single point source category. Applicable SIC codes for some facilities can span multiple potential point source categories. Facilities may also report under different SIC codes for different databases or reporting years.

For example, Dow Chemical in Midland, MI has several applicable SIC codes. Two of the applicable SIC codes are 2899 and 2869. SIC code 2899 is part of the potential new CFPR subcategory; SIC 2869 is included in the OCPSF category. Dow Midland reported SIC code 2899 to TRI in 2000 as its primary SIC code and SIC code 2869 as its secondary SIC code, and reported SIC 2869 to PCS in 2000. Because EPA determined that the toxic pollutants associated with dioxin discharge are derived from OCPSF (SIC code 2869) operations, EPA included discharges from Dow Midland in the dioxin-discharging group of OCPSF (discussed in Section 6.8). Therefore, Dow Midland is not included in the CFPR discussion.

EPA obtained information on the number of facilities in the SIC codes identified as CFPR industries from three sources: the 1997 U.S. Economic Census, the 2000 TRI database, and the 2000 PCS database. The 2000 TRI database includes reports of discharges to any media from all facilities that meet TRI reporting requirements. In contrast, the 2000 PCS database includes only facilities that are permitted for discharge to surface waters. Table 6-46 lists the number of CFPR facilities from these sources. The number of facilities reporting discharge to TRI for 2000 represents only about 6 percent of the CFPR industry based on the total number of facilities in the 1997 U.S. Economic Census. Of the facilities reporting discharge to TRI, 84 percent are indirect dischargers. The number of facilities reporting discharges to PCS for 2000 represents about 2 percent of the total industry. Only 14 of the PCS facilities (17 percent of the total PCS facilities) are major facilities with loads estimated from PCS data.

Table 6-46. Counts of CFPR Facilities

SIC Code	Facility Count (1997 U.S. Economic Census)	2000 PCS			2000 TRI				
		Total	Major	Minor	Total	No Reported Discharge	Direct Discharge	Indirect Discharge	Both Direct and Indirect Discharge
2842	727	6	1	5	97	57	0	39	1
2844	737	12	1	11	39	19	0	20	0
2891	694	17	2	15	158	123	3	31	1
2899	1,157	47	10	37	284	174	15	82	13
Total	3,315	82	14	68	578	373	18	172	15

Sources: PCSLoads2000 and TRIRelases2000.

Based on information presented in the 1997 study, CFPR operations are located across the United States with the largest number of facilities in California, Illinois, New Jersey, Ohio, and Texas. Moderate numbers of facilities are located in the Midwest, Indiana, and Georgia.

6.10.2 Process Descriptions and Wastewater Sources

This subsection discusses the processes and the wastewater sources present at CFPR operations.

6.10.2.1 CFPR Processes

CFPR operations formulate, package, and repackage a very large variety of chemical products. Because of the large number of products a facility may handle, most CFPR facilities operate on the principle of “just-in-time” production, which bases production on customer demand, to reduce the space needed to keep large inventories on hand. However, because the products that are formulated, packaged, or repackaged can vary from day to day and from hour to hour, facilities often dedicate an equipment line (e.g., a liquid formulating line) to

make multiple products over the course of a day, week, or month. Some facilities, typically those producing large volumes of certain products, operate long production campaigns and keep some inventory on site. Facilities that run long campaigns tend to generate less wastewater from product changeover. However, as customer demands change, such facilities may switch some or all production to “just-in-time” operations.

Operations at CFPR facilities may include:

- Liquid Formulating - Mixing several raw materials, including a base solvent, fragrances, and other inert ingredients such as emulsifiers or surfactants;
- Dry Formulating - Mixing powders, dusts, granules, block, impregnated solids, compounds that are formed into a solid shape, or microencapsulated dusts or granules;
- Liquid Packaging - Transferring the liquid final product into a package;
- Dry Packaging - Transferring the dry final product into a package;
- Aerosol Packaging - Placing the product in spray cans that are pressurized, and adding a propellant; and
- Repackaging - Transferring a formulated and packaged product into a new container.

6.10.2.2 CFPR Process Wastewater

Process wastewater in CFPR industries result from cleaning production equipment and related process areas. The typical process wastewaters found in the CFPR industry include:

- Interior equipment cleaning rinsate;
- Floor wash;
- Exterior equipment cleaning rinsate;
- Bulk tank rinsate;
- Drum/shipping container rinsate;
- Department of Transportation leak test bath water (for aerosol products);
- Leak and spill cleanup water;
- Air or odor pollution control scrubber water;
- Contact cooling water; and
- Safety equipment wash water.

6.10.3 Pollutants of Concern

This section presents PCS and TRI data pollutant data and discussions of the pollutants of concern in each CFPR sector (SIC codes 2842, 2844, 2891, and 2899).

6.10.3.1 PCS and TRI Data for the CFPR Industry

Table 6-47 lists the pollutants reported to TRI as discharged directly or indirectly, which account for 95 percent of the total TWPE for CFPR facilities that reported to TRI for 2000. This table presents the number of facilities that reported each chemical, total pounds of chemical discharged to surface waters, and the direct, indirect, and total TWPE for each chemical. Indirect discharging facilities reported transfers to POTWs. Using average POTW removal efficiencies, EPA estimated the amount of pollutant discharged to surface water (see DCN 00618, *Evaluation of RSEI Model Runs*, for more information). Therefore, EPA adjusted the TWPE estimates in this table to account for POTW treatment. As explained in Section 2.1, the 2000 TRI database does not include all CFPR facilities or TRI-listed chemicals that are used or produced at levels below reporting thresholds.

Table 6-47. Chemical Releases to Surface Water Reported to TRI for 2000

Pollutant	Number of Facilities Reporting	TRI Total (lbs/yr)	TRI Direct TWPE	TRI Indirect TWPE ¹	TRI Total TWPE	Percentage of Total SIC Code TWPE	Cumulative Percentage of Total SIC Code TWPE
SIC 2842 - Specialty Cleaning, Polishing, and Sanitation Preparation							
Sodium Nitrite	2	2,924	-	1,091	1,091	74%	74%
Chlorine	2	741	-	361	361	24%	98%
Total		31,943	<1	1,480	1,480		
SIC 2844 - Perfumes, Cosmetics, and Other Toilet Preparations							
Sodium Nitrite	2	18,455	-	6,890	6,890	99.7%	99.7%
Total		29,395	-	6,908	6,908		
SIC 2891 - Adhesives and Sealants							
Manganese Compounds	1	2,825	-	199	199	45%	45%
Polycyclic Aromatic Compounds	1	0.4	81	-	81	18%	63%
Copper compounds	1	70	-	44	44	10%	73%
Ammonia	5	27,164	10	31	41	9%	82%
Chromium compounds	2	61	-	31	31	7%	89%
Vinyl acetate	9	4,011	-	16	16	4%	92%
Zinc Compounds	4	181	<1	8	8	2%	94%
n-Hexane	2	294	8	<1	8	2%	96%
Total		39,173	105	342	446		

Table 6-47 (Continued)

Pollutant	Number of Facilities Reporting	TRI Total (lbs/yr)	TRI Direct TWPE	TRI Indirect TWPE ¹	TRI Total TWPE	Percentage of Total SIC Code TWPE	Cumulative Percentage of Total SIC Code TWPE
SIC 2899 - Chemicals and Chemical Preparations, Not Elsewhere Classified							
Sodium Nitrite	11	169,267	57,765	5,428	63,193	94%	94%
Copper compounds	16	1,424	86	807	893	1%	95%
Total		952,412	58,388	8,969	67,357		

Source: *TRIRelases2000*.¹TWPE transferred to POTW that are ultimately discharged to surface waters. Accounts for POTW removals.

Table 6-48 lists the pollutants reported to PCS, which account for 95 percent of the total TWPE for CFPR facilities that reported discharges to PCS for 2000.

Table 6-48. Pollutant Discharges Reported to PCS for 2000

Pollutant	Number of Facilities Reporting	PCS Total (lbs/yr)	PCS TWPE	Percentage of Total SIC Code TWPE	Cumulative Percentage of Total SIC Code TWPE
SIC 2842 - Specialty Cleaning, Polishing, and Sanitation Preparation					
Total		NA	NA		
SIC 2844 - Perfumes, Cosmetics, and Other Toilet Preparations					
Copper, Total (as Cu)	1	0.2	0.2	48%	48%
Nitrogen, Nitrate Total (as N)	1	1,620	0.1	29%	77%
Nitrogen Ammonia, Total (as NH ₃)	1	31	0.05	13%	90%
Zinc, Total (as Zn)	1	0.7	0.03	10%	100%
Total		47,998	0.3		
SIC 2891 - Adhesives and Sealants					
Chlorine, Total Residual	1	120	58	49%	49%
Barium, Total (as Ba)	1	21,667	43	37%	86%
Nitrogen, Ammonia Total (as NH ₃)	1	6,404	12	10%	96%
Total		1,950,573	118		
SIC 2899 - Chemicals and Chemical Preparations, Not Elsewhere Classified					
Benzo(a)pyrene	1	6	27,753	79%	79%
Benzo(b)fluoranthene (3,4-benzo)	1	6	2,730	8%	87%
Copper, Total (as Cu)	5	1,923	1,206	3%	90%
Benzo(a)anthracene	3	6	1,173	3%	94%
Chlorine (as Cl)	4	23,329,838	568	2%	95%
Total		53,423,544	35,086		

Source: *PCSLoads2000*.

NA - Not applicable; this facility reported no flow to PCS in 2000.

6.10.3.2 Pollutants of Concern for SIC Code 2842

As shown in Table 6-47, pollutants of concern in SIC code 2842 include sodium nitrite and chlorine. Both pollutants were reported in indirect discharges by two facilities. More than 99 percent of the TRI TWPE for SIC 2842 is from indirect releases and less than 1 TWPE was reported from direct dischargers.

Only one major facility reported to PCS in 2000 for this industry (see Table 6-48). This facility reported zero flow; therefore, EPA estimated no loads from this facility.

6.10.3.3 Pollutants of Concern for SIC Code 2844

The TRI pollutant of concern in SIC code 2844 is sodium nitrite, as presented in Table 6-47. All of the reported TWPE in this industry are from indirect dischargers.

Only one major facility reported to PCS in 2000 for SIC 2844. As shown in Table 6-48, the PCS pollutants of concern for this facility are copper, nitrogen, ammonia, and zinc and amounted to 0.3 TWPE/yr.

6.10.3.4 Pollutants of Concern for SIC Code 2891

The TRI pollutants of concern in SIC code 2891 include manganese compounds, polycyclic aromatic compounds (PACs), copper compounds, ammonia, chromium compounds, vinyl acetate, zinc compounds, and n-hexane (shown in Table 6-47). Most (77 percent) of the TWPE from this industry was reported in indirect discharges. Of the facilities that reported water discharges to TRI, 91 percent are indirect dischargers.

Only two major facilities reported to PCS in 2000 for SIC code 2891. Only one facility reported some pollutant discharge. The PCS pollutants of concern for this facility are chlorine, barium, and ammonia.

A 1984 study of the adhesives and sealants industry prepared by E.C. Jordan Co. entitled *Summary of Findings: Water and Waste Management for the Adhesives and Sealants Manufacturing Point Source Category* presents pollutant data from a 1978 sampling effort. (The January 22, 2004 memorandum *Summary of Adhesives and Sealants Industry Study*, DCN 00726, Section 4.17 presents a more detailed review of this study). The pollutants estimated to have the highest annual loads in raw wastewater in the 1978 sampling effort include:

- Zinc;
- Pentachlorophenol;
- Butylbenzyl phthalate;
- Bis(2-ethylhexyl)phthalate;
- Di-n-butyl phthalate;
- Phenol;
- Chromium;

- Toluene;
- 1,1,1-trichloroethane;
- Benzene;
- Trichloroethylene; and
- Diethyl phthalate.

However, the pollutant estimates presented in the 1984 study were complicated by several fundamental problems including analytical problems in determining concentrations, a lack of common industry-wide characteristics that could be used as an industry baseline, a lack of complete data for every segment of the industry, and day-to-day and plant-to-plant pollutant concentration variations.

6.10.3.5 Pollutants of Concern for SIC Code 2899

As shown in Table 6-47, the TRI pollutants of concern in SIC code 2899 are sodium nitrite (94 percent of the total TWPE) and copper compounds (1 percent of the total TWPE). The TRI TWPE for SIC code 2899 is dominated by one facility; 3M in Cottage Grove, MN represents 75 percent of the total CFPR industry TWPE (see Section 6.10.4.1 for a discussion of this facility's permit).

The PCS pollutants of concern include benzo(a)pyrene, benzo(b)fluoranthene (3,4-benzo), copper, benzo(a)anthracene, and chlorine. The PCS TWPE for SIC code 2899 is dominated by one facility; Ondeo Nalco in Garyville, LA represents 91 percent of the total CFPR TWPE (see Section 10.4.1 for a discussion of this facility's permit). Ondeo Nalco discharges most of the reported releases of PACs. EPA contacted this facility to verify its various PACs discharges reported to PCS for 2000. The facility did not detect the compounds; the reported discharges were estimated to be half the detection limit. EPA obtained Ondeo Nalco monitoring data, which verified that the compounds were not detected during wastewater sampling.

6.10.3.6 Total TWPE for CFPR Operations

Table 6-49 presents the total PCS and TRI TWPEs by SIC code for all CFPR sectors. As shown in the table, SIC code 2899 accounts for about 88 percent of the total TRI TWPE and greater than 99 percent of the total PCS TWPE. Also, SIC code 2899 is the only industry reporting more direct discharges than indirect discharges to TRI.

The TRI pollutants of concern for the entire CFPR industry are sodium nitrite, copper, manganese, and chlorine. The PCS CFPR pollutants of concern are benzo(a)pyrene, benzo(b)fluoranthene, and copper.

As explained above, the TRI TWPE for SIC 2899 is dominated by a single facility (accounting for 75 percent of the total TWPE). Similarly, the PCS TWPE is dominated by a separate, single facility (accounting for 91 percent of the total TWPE). See Section 10.4.2 for more information on these two facilities.

Table 6-49. PCS and TRI TWPEs by SIC Code for CFPR Sectors

SIC Code	Number of Major PCS Facilities Reporting	PCS TWPE	Number of TRI Facilities Reporting	TRI Total TWPE	Number of TRI Direct Facilities Reporting ¹	TRI Direct TWPE	Number of TRI Indirect Facilities Reporting ¹	TRI Indirect TWPE
2842	1	0	40	1480	1	<1	40	1,480
2844	1	0.3	20	6980	0	0	20	6,980
2891	2	118	35	446	4	105	32	342
2899	10	35,086	110	67,357	28	58,388	95	8,969
Total	14	35,204	205	76,191	33	58,492	187	17,699

¹Includes facilities that report both direct and indirect discharge.

6.10.4 Wastewater Treatment/Best Management Practices

This section discusses the wastewater treatment and BMPs in place at CFPR operations.

6.10.4.1 CFPR Wastewater Treatment

Facilities can report wastewater treatment practices to TRI. In 2000, CFPR facilities reported almost 40 different types of wastewater treatment to TRI. Table 6-50 lists the types of treatment reported most frequently.

Table 6-50. Wastewater Treatment Practices at CFPR Facilities

Treatment	Number of Direct Facilities Reporting Treatment	Number of Indirect Facilities Reporting Treatment
Neutralization	10	54
Settling/Clarification	11	32
Chemical Precipitation - Lime or Sodium Hydroxide	7	23
Filtration	6	18
Equalization	3	16
Sludge Dewatering (nonthermal)	4	14
Biological Treatment - aerobic	8	8
Chemical Precipitation- other	3	7
Other Chemical Treatment	0	7

Pollution prevention, recycle, and reuse practices are widely used in CFPR operations. These practices include:

- Dedicating equipment to one product, to reduce cleaning requirements;
- Storing of rinsates for reuse in subsequent batches;
- Using water conservation equipment;
- Packaging directly into product containers;
- Scheduling production to minimize cleanouts; and
- Using good housekeeping practices to prevent and quickly clean up leaks and spills.

6.10.4.2 Permit Review Summary

EPA obtained surface water discharge permits for 3M, Cottage Grove, MN, and Ondeo Nalco, Garyville, LA. These facilities are direct dischargers with manufacturing operations in SIC codes that are included in the potential new CFPR subcategory. The following summarizes of the basis used to develop the permit limits as described in the permit documents. For more detailed information, please see the May 14, 2004 memorandum *Review of Top Chemical Formulating, Packaging, and Repackaging Facilities*.

- Both facilities report SIC code 2899.
- Permit limitations for both facilities were based on the OCPSF effluent guidelines.
- The highest TWPE pollutant reported by 3M Cottage Grove, MN to TRI for 2000 is sodium nitrite.
 - Limits for nitrite and sodium nitrite are not included in 3M's permit, and
 - Due to the diversity of chemical manufacturing operations in place at this facility, it is unclear if sodium nitrite discharges result from CFPR processes.
- The highest TWPE pollutants reported by Ondeo Nalco Garyville, LA to PCS for 2000 are individual PACs.
 - Permit limits are assigned for the reported PACs, and
 - Monitoring data show that PACs were not detected in the facility's wastewater, but were reported at one half the method detection

limit to PCS. Therefore, PCS data overestimate the facility's TWPE by 31,947 lb-eq.

6.10.5 Conclusions

The screening-level review showed that the majority of facilities reporting to TRI reported no wastewater discharge. Of the facilities that reported discharge, most transferred their wastewater to a POTW. Only 0.5 percent of the facilities in the 1997 U.S. Economic Census reported direct wastewater discharge to TRI. Two facilities generate most of the TWPE in this industry, and NPDES permits for these facilities are based on OCPSF effluent limitations guidelines. Because of the small number of CFPR facilities that discharge significant toxic-weighted pounds to waters of the United States, EPA concludes it is not appropriate to develop a new CFPR subcategory under the OCPSF ELG at this time. If EPA receives data during subsequent annual reviews that indicate otherwise, EPA may reconsider this sector of OCPSF for development at that time.

EPA recommends that permit writers prepare permits for those facilities that discharge high TWPE based on existing OCPSF limitations on a BPJ basis. Permit writers might also want to review and consider pollution prevention alternatives described in the *Pollution Prevention (P2) Manual: Implementing the P2 Alternative (23)* developed for Pesticide Formulating Packaging and Repackaging (PFPR) facilities. Because many of the operations and wastewater sources at CFPR facilities are similar to those at PFPR facilities, EPA believes the pollution prevention practices identified for PFPR facilities are applicable to CFPR facilities.

6.11 References

1. 1997 U.S. Census. Available online at: <http://www.census.gov>.
2. American Plastics Council and International Institute of Synthetic Rubber Producers. Available online at: http://pubs.acs.org/cen/coverstory/8127/pdf/8127/fandf_production.live.pdf.
3. Amini, B. and S. Lowenkron. 2003. *Aniline and Its Derivatives*. Kirk Othmer Encyclopedia.
4. Baron, J, C. Kraynik, and R. Wombles. *Strategies for a Declining North American Coal Tar Supply*. Koppers Industries Inc., Technical Center, Pittsburgh, PA. 1998.
5. Chlorine Institute. *North American Chlor-Alkali Industry Plants and Production Data Report 2003*.
6. Dover Chemicals Web page, <http://www.doverchem.com>.
7. Dow Chemical Web page, <http://www.dow.com>.

8. The Innovation Group Web Page, Chemical Profiles. Available online at: <http://www.the-innovation-group.com/chemprofile.htm>.
9. Lamberti, C., Prestipino, C., Bonino, F., Capello, L., et al. *Chemistry of the Oxychlorination Catalyst: An In Situ, Time-Resolved, Dispersive Xanes Study*. Accessed at: <http://www.esrf.fr/UsersAndScience/Publications/Highlights/2002/XASMS/SAXMS2/> on February 9, 2004.
10. Man Made Organic Materials - Part I, Innovision India Web page, http://home.att.net/~cat6a/org_mat-I.htm.
11. National Science Council Chemical Backgrounder for Aniline. Available online at: <http://www.nsc.org/library/chemical/aniline.htm>.
12. OxyVinyls Web page, <http://www.oxyvinyls.com>.
13. The Society of the Plastics Industry (SPI), <http://www.plasticsdatasource.org/impact.htm#topten>.
14. Thornton, J. *Environmental Impacts of Polyvinyl Chloride (PVC) Building Materials*. U.S. Green Building Council Briefing Paper for Center for Maximum Potential Building Systems and The Healthy Building Network. Columbia Earth Institute, Columbia University. 2002.
15. U.S. EPA. *Best Demonstrated Available Technology (BDAT) Background Document for Chlorinated Aliphatics Production Wastes - K173, K174, K175*. Washington, D.C. July 1999.
16. U.S. EPA. *Best Demonstrated Available Technology (BDAT) Background Document For Dye and Pigment Production Wastes - Deferred Wastes K167 and K168*. Washington, D.C. June 11, 1999.
17. U.S. EPA. *Development Document for Effluent Limitations Guidelines, New Source Performance Standards, and Pretreatment Standards for the Organic Chemicals and the Plastics and Synthetic Fibers Point Source Category*. Washington, D.C. October 1987.
18. U.S. EPA. *Emergency Planning and Community Right-to-Know Act Section 313 Guidance for Reporting Toxic Chemicals within the Dioxin and Dioxin-Like Compound Category*. Washington, D.C. December 2000.
19. U.S. EPA. *Listing Background Document for the Chlorinated Aliphatics Listing Determination (Final Rule)*. Washington, D.C. June 30, 2002.

20. U.S. EPA. National Risk Management Research Laboratory Treatability Database.
21. U.S. EPA. *Hazardous Air Pollutant Emissions from Mercury Cell Chlor-Alkali Plants: Background Information Document for Proposed Standards*. EPA-4531R-02-007. Washington, D.C. February 2002.
22. U.S. EPA. Office of Compliance Sector Notebook Project. *Profile of the Organic Chemical Industry 2nd Edition*. EPA/310-R-02-001. Washington, D.C. November 2002.
23. U.S. EPA. *Pollution Prevention (P2) Guidance Manual for the Pesticide Formulating, Packaging, and Repackaging Industry: Implementing the P2 Alternative*. EPA-821-B-98-017. Washington, D.C.
24. Van den Berg, et al. "Toxic Equivalency Factors (TEFs) for PCBs, PCDDs, PCDFs, for Humans and Wildlife." *Environ. Health Perspect.* 106:775-792. 1998.
25. Vinyl Institute. *The Vinyl Institute Dioxin Characterization Program. Final Report*. May 15, 2001.
26. Whole Earth Magazine, <http://www.wholeearthmag.com/ArticleBin/113.html>.
27. Wombles, Robert H. (Koppers Industries, Inc.) and Melvin D. Kiser (Marathon Ashland Petroleum Company). *Developing Coal Tar/Petroleum Pitches*. Koppers Industries Company web site, <http://www.koppers.com>.
28. World Chlorine Council. *Turning Salt into Chlorine and Caustic Soda: Chlor-Alkali Manufacturing Processes*. Accessed at <http://www.worldchlorine.com>. 2002.
29. Zipf, Lynn, U.S. EPA. *Revisions to TWFs for Dioxin and its Congeners and Recalculated TWPEs for OCPSF and Petroleum Refining*. (EPA Docket Number OW-2003-0074). August 10, 2004.

SECTION 7 PETROLEUM REFINING

7.1 Introduction

The petroleum refining industry corresponds to *Standard Industrial Classification (SIC) code 2911 - Petroleum Refining*, defined as establishments engaged in producing gasoline, kerosene, distillate fuel oils, residual fuel oils, and lubricants, through fractionation or straight distillation of crude oil, redistillation of unfinished petroleum derivatives, cracking, or other processes. EPA is also considering including operations in *SIC code 5171 - Petroleum Bulk Stations and Terminals* as a new subcategory in the Petroleum Refining Point Source Category.

EPA selected the Petroleum Refining category for further review because it ranked fourth highest among all point source categories for toxic and nonconventional pollutant discharges for 2000 in the screening-level analysis (see the December 31, 2003 Notice of the Preliminary Effluent Guidelines Program Plan, FRN [FRL-7604-7]). The effluent guidelines, limitations, and standards (ELGs) for the Petroleum Refining category are codified at 40 CFR Part 419 (last revised in 1982). In the screening-level analysis, EPA found that the toxic and nonconventional pollutant loadings are driven by three groups of pollutants: polycyclic aromatic compounds (PACs), polychlorinated dibenzo-para (p)- dioxins and polychlorinated dibenzofurans (referred to as “dioxins” in this report), and metals (specifically vanadium, mercury, and selenium). EPA analyzed the reported discharges and specific process sources discharging these pollutants.

For the detailed review of the Petroleum Refining category, EPA verified Toxic Release Inventory (TRI) and Permit Compliance System (PCS) data, analyzed additional industry data, reviewed current regulations affecting this industrial category, and identified pollution prevention and treatment technologies for wastewater discharges.

EPA also analyzed data from petroleum bulk stations and terminals (PBSTs) to determine if a new subcategory of the Petroleum Refining category should be identified and further studied. Currently, states determine whether process discharges from PBST operations are regulated. Section 7.12 discusses EPA’s findings on this investigation.

This section discusses EPA’s analysis of the Petroleum Refining category and conclusions in the following order:

- Section 7.2 discusses data sources used, EPA’s verification of the data, and the data source limitations;
- Section 7.3 discusses the petroleum refining industry profile and discharge status;
- Section 7.4 discusses the current petroleum refining ELGs (40 CFR Part 419) and other major regulations affecting petroleum refineries;

- Section 7.5 discusses wastewater sources, pollutant loadings, and current treatment in place at refineries;
- Section 7.6 discusses EPA's analysis and findings for PACs discharges from petroleum refineries;
- Section 7.7 discusses EPA's analysis and findings for dioxin discharges from petroleum refineries;
- Section 7.8 discusses EPA's analysis and findings for metals discharges from petroleum refineries;
- Section 7.9 discusses EPA's analysis and findings for other nonconventional and conventional pollutant discharges from petroleum refineries;
- Section 7.10 discusses control of wastewater discharges from petroleum refineries, including pollution prevention and wastewater treatment technologies;
- Section 7.11 lists references for the petroleum refining detailed study; and
- Section 7.12 discusses EPA's findings on PBSTs.

7.2 Data Sources

This section describes the data sources used for the petroleum refining industry detailed study, as well as data quality limitations and data verification activities performed. Sections 4.2.1, 4.2.2, and 4.1.3 of this document describes TRI, PCS, and U.S. Economic Census data sources, respectively. This section discusses data sources as they pertain specifically to the petroleum refining industry detailed review.

7.2.1 Toxic Release Inventory (TRI)

All petroleum refineries that meet the employee criteria (i.e., 10 or more employees) and the chemical threshold(s) must submit reports to EPA's TRI program. Of the 163 petroleum refineries operating in the U.S. in 2000, 154 (94 percent) reported to TRI in 2000. EPA used 2000 TRI data, as reported, to estimate pollutant loadings, determine if stormwater discharges were an industry issue, and identify treatment in place.

To estimate pollutant loadings and toxic-weighted pound equivalents (TWPEs), EPA developed the *TRIReleases2000* database (35); this database includes all data as reported to TRI in 2000. The pollutant loadings estimated by *TRIReleases2000* uses pollutant releases and transfers to publicly-owned treatment works (POTWs), taking POTW removals into account.

Section 4.2.1 discusses the *TRIReleases2000* database in further detail. Section 4.2.4 discusses TWPE calculations.

For the petroleum refining industry detailed review, EPA verified data as reported to TRI in 2000, particularly for those facilities and pollutants with high TWPEs. For example, refineries may estimate TRI-reported releases in a number of ways: monitoring data, emissions factors, mass balances, and other engineering calculations. If a chemical is not detected in the effluent, refineries may estimate the discharge by using one-half of the detection limit. By using one-half the detection limit, refineries may overestimate the amount of chemical discharged, which particularly affected PACs and dioxin discharges reported for petroleum refineries.

The list of chemicals reportable to TRI includes individual chemicals and chemical categories (i.e., group of similar chemicals). The TRI chemical categories commonly reported by petroleum refineries include the PACs category (21 individual chemicals; see Section 7.6 for more detail), dioxins and dioxin-like chemicals category (17 individual chemicals; see Section 7.7 for more detail), and metal compound categories (e.g., mercury compounds, vanadium compounds).

Refineries are required to report the combined mass of PACs and dioxins released. To calculate the TWPE of PACs as reported to TRI in 2000, EPA calculated a toxicity weighting factor (TWF) specific to the petroleum refining industry (see Section 7.6.2).

For dioxins, refineries are given the opportunity to report a refinery-specific congener distribution. To calculate the TWPE of dioxins as reported to TRI in 2000, EPA calculated a TWF specific to a petroleum refinery based on the reported congener distribution (see Section 7.2). Note that the dioxin congener distribution for a refinery may not accurately reflect the distribution across all media. See also Section 4.2.4.2 for a more detailed discussion on dioxins and the calculation of TWPE for dioxin discharges.

Refineries report only the elemental metal portion of discharges for metal compounds (e.g., a refinery reports only the pounds discharged of vanadium for all vanadium compounds). Therefore, EPA used the metal TWFs to calculate the TWPE.

To verify the data reported to TRI, EPA performed the following activities:

- Verified that facilities reporting as SIC code 2911 were petroleum refineries and linked each refinery's data with data from the PCS and the Energy Information Administration (EIA), discussed in Section 7.2.1.1;
- Verified data reported to TRI for two refineries, discussed in Section 7.2.1.2;
- Met with representatives of a refinery and industry trade associations to discuss pollutant loadings estimated using TRI and PCS data, discussed in Section 7.2.1.3; and

- Reviewed comments submitted in response to the December 31, 2003 Notice of the Preliminary Effluent Guidelines Program Plan, FRN [~~FRL-7604-7~~], discussed in Section 7.2.1.4.

7.2.1.1 Identification of Petroleum Refineries Operating in 2000

EPA linked refineries reporting to TRI and PCS with EIA's list of refineries operating in 2000. See Section 7.2.4 for a brief description of EIA's *Refinery Capacity Data* (21), used in this review. For refineries not included in EIA's list, EPA investigated whether the facilities were actually petroleum refineries. EPA found that eight facilities that reported to TRI, nine facilities that reported to PCS, and one that reported to both, were not operating refineries. A number of these facilities were closed in or prior to year 2000. Others turned out to be chemical manufacturers, PBSTs, or other nonrefinery operations. Table 7-1 lists these facilities and the rationale for excluding each facility from the list of existing petroleum refineries in this detailed review. The 18 facilities listed in Table 7-1 were excluded from the petroleum refining industry detailed review and reclassified in *TRIRelases2000*.

7.2.1.2 Refinery-Specific Verification of TRI Data

EPA contacted the Lyondell-Citgo refinery in Houston, TX to verify the data as reported to TRI in 2000. Lyondell-Citgo representatives confirmed that the refinery discharged 2,380 pounds of PACs to a POTW in 2000. In addition, the refinery submitted the individual PAC concentrations in the refinery effluent (untreated wastewater and stormwater) (15). The refinery discharges the wastewater to the Gulf Coast Waste Disposal Authority's Washburn Tunnel Facility for biological treatment. EPA also received effluent data from the Washburn Tunnel Facility's *2003 Peak Performance Award Application* (9).

The Marathon Ashland Petroleum LLC refinery in Detroit, MI submitted a request-for-withdrawal form to EPA to correct the reported releases of dioxins in 2000. The refinery incorrectly reported 8.0613 grams of dioxins discharged to a POTW. The request-for-withdrawal stated that the refinery discharged zero grams of dioxins in 2000. EPA updated the *TRIRelases2000* database to reflect this reporting change.

Table 7-1. Facilities Reporting to TRI and PCS Under SIC Code 2911 that are Not Operating Refineries

Facility Name	Facility Location	Database	Rationale for Exclusion as Refinery
Buckeye Refining Co. L.L.C.	Indianola, PA	TRI	Facility is a petroleum bulk terminal.
Pennzoil-Quaker State Co. Rouseville Refinery & Packaging	Rouseville, PA	TRI	Facility should be classified as SIC code 2999 and was shut down in January 2000.
Calumet Lubricants Co. Rouseville Plant	Rouseville, PA	TRI	Facility should be classified as SIC code 2999 and was shut down in 2001.
International Petroleum Corp.	Plant City, FL	TRI	Facility is a waste oil recycling plant.
Merichem Chemicals & Refinery Services L.L.C.	Tuscaloosa, AL	TRI	Facility is a chemical processing plant.
Two Wastewater Treatment Unit	Oregon, OH	TRI	Facility is a wastewater treatment facility for Sunoco Inc. (R&M): NPDES Permit Number 43616SNRFN1819W.
Golden West Refining Co.	Santa Fe Springs, CA	TRI	Facility ceased operations in 1992.
Chevron Products Co. Richmond Beach Asphalt Refinery	Seattle, WA	TRI	Facility is an asphalt plant.
Total Petroleum Inc.	Arkansas City, KS	PCS	Facility was closed in 1996.
Penreco	Karns City, PA	PCS	Facility is a petrochemical manufacturing facility.
American Western Refining	Lawrenceville, IL	PCS	Facility was closed in 1995.
Longview Refining Assoc. Inc.	Longview, TX	PCS	Facility is closed and is a Superfund site.
Gulf Chemical Corporation	Penuelas, PR	PCS	Facility is a chemical processing plant.
Commonwealth Oil Petrochemical	Penuelas, PR	PCS	Facility is not an active refinery; currently a petroleum bulk terminal.
Cenco Refining Company	Santa Fe Springs, CA	PCS	Facility was shut down.
The Carbide/Graphite Group Inc.	Seadrift, TX	PCS	Facility manufactures calcium and graphite.
Berry Petroleum Co. - Stephens	Stephens, AR	PCS	Facility was shut down in February 2000 and last operated in July 1999.
Neches River Treatment Corporation Lower Neches Valley	Beaumont, TX	TRI, PCS	Facility is a centralized waste treatment facility.

7.2.1.3 Meetings with Representatives from Refinery and Trade Associations

EPA met with representatives of the American Petroleum Institute (API) and National Petrochemical and Refiners Association (NPRRA) on February 11, 2004. Prior to the meeting, API and NPRRA sent a list of questions concerning the petroleum refining detailed review to EPA. These questions and topics discussed during the meeting included the detailed review work plan (Section 3.06, DCN 00701, EPA Docket OW-2003-0074), factors considered for the review, use of the *1996 Preliminary Data Summary*, dioxin TWFs, pollutant loading estimates, and the review of PBSTs. See the memorandum entitled *Meeting Between EPA and Representatives of American Petroleum Institute and National Petrochemical and Refiners Association* (5).

EPA met with representatives of Lyondell-Citgo Refining, LP on March 12, 2004 to discuss the operation and wastewater discharges of their Houston, TX refinery. Representatives from the refinery presented an overview of the refinery and its wastewater discharges. The refinery discharges to the Washburn Tunnel facility, a POTW operated by the Gulf Coast Waste Disposal Authority. The Lyondell-Citgo refinery and one other refinery contribute about 50 percent of the wastewater flow to the Washburn Tunnel. Gulf Coast Waste Disposal Authority has never detected PACs in the effluent from the Washburn Tunnel facility. EPA explained how the *TRI Releases 2000* database estimates the refinery's pollutant discharge of PACs by assuming the POTW (Washburn Tunnel) removes 92 percent of mass as reported to TRI. See the memorandum entitled *Meeting Between EPA and Representatives of Lyondell-Citgo Refining, LP* (6).

7.2.1.4 Comments Received in Response to the Federal Register Notice of the 2004/2005 Preliminary Effluent Guidelines Program Plan

EPA received comments specific to petroleum refining from NPRRA, API, and the County Sanitation Districts of Los Angeles County. The comments are summarized below.

NPRRA submitted comments regarding EPA's use of data as reported to TRI for screening purposes. NPRRA stated that an investigation of TRI reporting basis should be performed before using the values in a screening assessment. NPRRA submitted refinery-specific comments on TRI data that EPA used to estimate TWPE for PACs and dioxins. Based on EPA's *TRI Reporting Forms and Instructions*, refineries may estimate releases of nondetected pollutants using one-half the detection limit to avoid under-reporting. See Sections 7.6.5 and 7.7.4.4 for specific industry comments on PACs and dioxins.

API submitted comments regarding EPA's use of TRI data for screening purposes and provided information on how its member refineries estimated the discharges of PACs and dioxins for TRI. Most refineries do not detect PACs and dioxins in the effluent, but use the detection limit (or other methods) to estimate the mass of pollutant releases to wastewaters. See Sections 7.6.5 and 7.7.4.4 for specific comments on PACs and dioxins. API agreed with EPA that using the benzo(a)pyrene TWF for TWPE calculations (used for the screening-level analysis) is a worst-case scenario. In its comments, API used EPA's revised TWF (based on

distribution of PACs in refinery products) to recalculate PAC loadings. API also submitted effluent data from 10 refineries performing activated sludge treatment that were collected during 1993-1994 in conjunction with EPA Office of Solid Waste (see Section 7.6.4.3).

The County Sanitation Districts of Los Angeles County (a group of 27 Districts) provided comments regarding the questions posed by EPA in the December 31, 2003 FRN. Thirteen refineries discharge wastewater to District facilities. The Districts' comments include a discussion of its analytical data for PACs, dioxins, and metals (selenium and vanadium). As noted in the comments, the Districts submitted analytical data (1984-1993) to EPA as part of the *1996 Preliminary Data Summary*. Since the *1996 Preliminary Data Summary*, the Districts have found that refinery wastewater quality has not varied greatly, except for a decrease in the concentrations of methyl tertiary-butyl ether (MTBE) and benzene, toluene, ethylene, and xylene (BTEX). The MTBE concentration decrease can be attributed to the ban of MTBE in gasoline in the state of California. The BTEX concentration decrease can be attributed to the promulgation of the Clean Air Act (CAA) National Emission Standards for Hazardous Air Pollutants (NESHAP) regulations in 1992 (3).

The Gulf Coast Waste Disposal Authority submitted comments on the December 31, 2003 FRN concerning the PACs TWPE discharges calculated by EPA (10). The comments note that PACs have never been detected in the effluent from the Washburn Tunnel Facility (which receives petroleum refining wastewater from the Lyondell-Citgo Refinery in Houston, TX and the Crown-Central Petroleum Refinery in Pasadena, TX). Gulf Coast Waste Disposal Authority submitted PAC discharge concentrations for 2000 through 2003. EPA verified the TRI discharges reported by the Lyondell-Citgo Refinery (see Section 7.2.1.2). For both refineries, EPA estimated the TWPE discharged to surface waters using its standard percent removal calculation (discussed in Section 4.2.4).

7.2.2 Permit Compliance System (PCS)

PCS is a computerized management information system maintained by EPA's Office of Enforcement and Compliance Assurance (OECA). This system contains only permit-required monitoring data for direct-discharging facilities. States may submit data from refineries' discharge monitoring reports (DMRs) to PCS. The data from each DMR will vary depending on the refinery's NPDES permit requirements. Refineries that discharge to a POTW, or that transfer their wastewater to a private waste treater, do not submit DMRs; therefore, their data are not in PCS. In addition, PCS typically does not include data for refineries that states classify as "minor sources."

The Effluent Data Statistics System (EDSS) is a system that EPA developed to estimate mass loadings based on data stored in PCS. EDSS uses PCS-reported mass loading values or calculates loadings using concentration and flow rate data, taking into account the various units of concentration and flow rates. EDSS and PCS are the major sources of data for the *PCSLoads2000* database. EPA selected permit facility data, parameter limits data, and measurement/violation data for major facilities to develop *PCSLoads2000* (34). Section 4.2.2 discusses the *PCSLoads2000* database in further detail.

The 2000 PCS includes data from 104 (63 percent) of the 163 refineries operating in the U.S. in 2000. To verify the data reported to PCS, EPA performed the following activities:

- Verified that facilities reporting as SIC code 2911 were petroleum refineries and linked each refinery's data with data from TRI and EIA, discussed in Section 7.2.1.1;
- Met with representatives of industry trade associations to discuss pollutant loadings estimated using data as reported to TRI and PCS, discussed in Section 7.2.1.3; and
- Reviewed comments submitted in response to the December 31, 2003 Federal Register notice of the Preliminary Effluent Guidelines Program Plan, FRN [FRL-7604-7], discussed in Section 7.2.1.4.

7.2.3 The U.S. Economic Census

The U.S. Economic Census of 1997, described in Section 4.1.3, provides data on the number of facilities by SIC code, but does not include a list of the facilities. The U.S. Economic Census of 1997 includes refineries that by 2000 were shut down or no longer operating and might also include nonproduction facilities. In contrast, EIA, which is part of the U.S. Department of Energy (DOE), publishes annual updates of the number of operating refineries, their capacities, and operations. EPA used EIA data for this detailed review, because the data provide more accurate and detailed data on each refinery. Consequently, EPA did not use census data in its analysis of the petroleum refining industry.

7.2.4 Data Sources Specific to the Petroleum Refining Industry

EPA used the following data sources specific to the petroleum refining industry in its detailed study.

- *Energy Information Administration (EIA)* - EIA tracks the number of operating refineries, their capacities, and operations. EPA downloaded capacity data from the EIA web site (21) and linked each refinery's crude petroleum operating capacity to the discharges reported to TRI and PCS. EPA also used data from EIA to identify the types of catalytic reforming at each refinery.
- *Oil & Gas Journal* - Provides general information about the petroleum industry and publishes worldwide refinery-specific capacities each year (12).
- *Washington Department of Ecology* - EPA reviewed dioxin study reports DOE required from four Washington State refineries (18, 36) and *Water*

Pollution Prevention Opportunities in Petroleum Refineries (37), a report of a state-funded study.

- *Dioxin Source Investigation Pursuant to Cease and Desist Order No. 95-151, Final Report* - Study prepared by Tosco Refining Company Avon Refinery to identify all sources of dioxins contributing to refinery's final effluent dioxin load (19). The report, based on 150 samples collected in 1996, provides source information and granulated activated carbon (GAC) treatment system percent removals for dioxins. The report does not provide detailed treatment performance data (e.g., influent and effluent concentrations).
- *EPA/EAD 1996 Preliminary Data Summary for the Petroleum Refining Category* (24) - Report describes the industry, pollutant discharges, environmental issues, regulatory standards, treatment technologies, and economic profile using data collected during 1992 and 1993.
- *Contacts with treatment technology vendors* - EPA contacted treatment technology vendors to gather information on new options to reduce pollutant concentrations in petroleum refining wastewater.
- *Industry-provided information/comments* - Discussed in Section 7.2.1.4.

7.3 Industry Description

The petroleum refining industry purifies (or refines) crude petroleum into various petroleum products. Products include gasoline, kerosene, distillate fuel oils, residual fuel oils, and lubricants. Refineries use various processes, such as fractionation, distillation, and cracking, to refine the crude petroleum. The industry is classified by SIC code 2911 (North American Industry Classification System (NAICS) code 32411).

7.3.1 Number of Refineries

In 2000, there were 163 petroleum refineries operating in the United States. EIA lists the industry capacity on January 1, 2001 as 16.6 million barrels of crude petroleum per day, with individual refinery capacities ranging from 880 to 508,000 barrels per day. EIA's *Refinery Capacity Data as of January 1, 2001* and the *Oil and Gas Journal's* "2001 Worldwide Refining Survey" list all the petroleum refineries, along with their capacities and other pertinent process information. (12, 21)

Refineries are located in 31 states, with most (43 percent) located in Texas, Louisiana, and California.

7.3.2 Discharge Status for Petroleum Refineries

EPA determined the discharge status of all petroleum refineries using data reported to TRI and PCS in 2000. Table 7-2 lists the discharge status for the 163 petroleum refineries operating in the U.S. during 2000.

In the PCS data system, facilities may be classified as major¹ or minor dischargers. States are not required to provide discharge data for minor facilities to PCS, and so reports for minor facilities are incomplete. For this reason, EPA did not use data from minor facilities in this review. Thirty two petroleum refineries are identified as minor dischargers in PCS.

Table 7-2. 2000 Discharge Status for Petroleum Refineries

EIA Number of Refineries	TRI 2000				PCS 2000	
	Direct Dischargers	Indirect Dischargers	Both	No Water Discharge Reported	Majors Dischargers	Minor Dischargers
163	94	21	13	26	103	32

Sources: *TRIRelases2000* and *PCSLoads2000*.

7.3.3 Overview of Refinery Operations

To refine the crude petroleum, refineries begin by desalting the crude and distilling it into its various components (or fractions). The next step is to convert the distillation fractions into petroleum products. These processes include cracking, coking (term refers to by-product coke (solid carbon with varying impurities) formed during the process), reforming, and alkylation. Other support operations include reformer catalyst regeneration, sulfur recovery, additive production, and product blending. This section presents descriptions of these operations, as detailed in EPA's *Industry Sector Notebook: Profile of the Petroleum Refining Industry* (32).

All refineries perform distillation operations; however, the extent and variety of processes used to convert distilled fractions into petroleum products varies greatly by refinery. "Topping" refineries perform only distillation operations – some perform only atmospheric distillation.

Many refinery operations generate sour waters. Sour waters generally result from water brought into direct contact with a hydrocarbon stream (e.g., when water is used as a washing medium or steam is used as a stripping or mixing medium). Sour waters contain sulfides, ammonia, phenols, and other organic chemical constituents of the crude oil.

¹Facilities are classified as "major" based on many factors, including effluent design flow, physical and chemical characteristics of the waste stream, and location of discharge.

7.3.3.1 Crude Petroleum Processing

The first steps in the petroleum refining process are to desalt the crude petroleum and separate the crude into its various petroleum fractions (i.e., unrefined product streams) using distillation. Each of these processes and resulting wastewater streams is discussed below.

Desalting

Petroleum refineries remove corrosive salts from the crude petroleum by mixing heated crude with water. The salt, along with some metals, suspended solids, and other water-soluble compounds, dissolves in the water. The refinery then separates the crude petroleum and desalter water using electrostatic separation and demulsification to break the emulsion and separate the two phases (oil/water separation). The desalter water is then discharged to the refinery treatment system. The raw water used for desalting is often untreated or partially treated wastewater from elsewhere at the refinery.

Distillation

Petroleum refineries use two types of distillation towers: 1) atmospheric distillation separates the lighter petroleum fractions, and 2) vacuum distillation separates the heavier petroleum fractions. Petroleum fractions separated using atmospheric distillation include naphtha, gasoline, kerosene, light fuel oil, diesel oils, gas oil, lube distillate, and heavy bottoms (further separated by steam strippers or vacuum distillation). The uncondensed refinery fuel gas, or sour gas, leaving from the top of the distillation tower contains primarily methane and ethane, along with hydrogen sulfide and ammonia. The refinery will treat the sour gas to recover the methane and ethane which is then used to heat furnaces at the refinery. Most refineries performing vacuum distillation use vacuum pumps and surface condensers; however, they may also use barometric condensers. The wastewater from distillation includes condensed steam from the tower (called oily sour water), which contains hydrogen sulfate and ammonia, and oily wastewater if barometric condensers are used for vacuum distillation.

7.3.3.2 Refining of Petroleum Fractions - Cracking, Coking, Hydrotreating/Hydroprocessing, Alkylation, Polymerization, and Isomerization

The petroleum fractions from the distillation step might be further refined at the refinery using a variety of processes. These processes modify the hydrocarbon molecular structure either by breaking them into smaller molecules, joining them into large molecules, or reshaping the molecules for higher quality. Process types include thermal cracking (visbreaking), catalytic cracking, catalytic hydrocracking, coking, hydrotreating, alkylation, isomerization, polymerization, and catalytic reforming (discussed on Section 7.3.3.3). Refineries might use multiple operations, discussed below.

Thermal cracking (visbreaking) breaks heavy gas oils and residues from distillation into smaller, lighter molecules using heat and pressure. Operations include preheating, reactor, cooling to stop the cracking reaction, flasher chamber (reduces pressure and

draws off lighter products), and fractionating tower (separates various petroleum fractions). The cooling step uses part of the heavy bottoms from the fractionating tower to cool the incoming process stream. Wastewater includes sour water from the fractionating tower.

Catalytic cracking breaks light and heavy oils from distillation into smaller, lighter molecules (primarily gasoline with some fuel oil and light gases) using heat, pressure, and a catalyst. Because catalytic cracking produces higher octane gasoline and less heavy fuel oils and light gases, it has largely replaced the thermal cracking process at petroleum refineries. The most common reactor types used for catalytic cracking are fluidized beds and moving beds (both with continuous catalyst regeneration); other types include fixed-bed reactors and once-through units. Catalysts are mixtures of crystalline, synthetic silica-alumina (zeolites) and amorphous, synthetic silica-alumina. Wastewater includes sour water from the fractionating tower.

During catalytic cracking, coke collects on the catalyst surface. To maintain catalyst properties, refineries need to regenerate the catalyst (either continuously or periodically). **Catalyst regeneration** involves burning the coke off the catalyst. Steam used to purge and regenerate catalysts might become wastewater contaminated with metal impurities from the feed stream.

Refineries use **catalytic hydrocracking** for petroleum fractions that are most difficult to crack (middle distillates, cycle oils, residual fuels oils, and reduced crudes) to produce gasoline. Catalytic hydrocracking typically uses a fixed-bed reactor under high pressure (1,200 to 2,000 psig) in the presence of hydrogen (increases gasoline yield). Prior to hydrocracking, feedstocks typically undergo hydrotreatment to remove impurities (hydrogen sulfide and ammonia) that might foul the catalyst during the process and water removal using silica gel or a molecular sieve dryer. The catalyst is typically a mixture of zeolites with small amounts of rare earth metals. Sour gas and sour water are both generated from the fractionating tower; however, hydrotreating the feedstock prior to cracking results in relatively low levels of impurities in both waste streams. Hydrocracking catalyst regeneration is typically performed off site.

Coking is a cracking process that breaks residual fuel oils into gasoline and diesel. A by-product of the process is petroleum coke (solid carbon with varying impurities). Refineries use two types of coking operations: 1) delayed coking and 2) fluid coking. The delayed coking process steps are the same as thermal cracking except the feed stream reacts longer without cooling. The heavy materials from the fractionating tower are fed into a coke drum (insulated vessel) to form petroleum coke. The coking process includes steam injection to the coke drum to remove hydrocarbon vapors (lighter products, hydrogen sulfide, and ammonia) and cooling water injection to cool the coke. The hydrocarbon vapors are fed back to the fractionating tower where they are removed as product streams or part of the sour gas. Wastewater from the coking drum includes any condensed steam, cooling water, and water used to remove the coke (high-pressure water jets).

Hydrotreating and **hydroprocessing** remove impurities (e.g., sulfur, nitrogen, oxygen, halides, and trace metals) from the feedstock to prevent fouling of the catalyst during

cracking and assist in forming higher-quality or lighter products in a fixed-bed reactor. Using catalysts, high pressure, high temperature, and hydrogen, the processes separate the treated product stream from the light fuel gas stream, hydrogen sulfide, and ammonia. The treated product stream is then cooled and the hydrogen-rich gas is recycled back to the reactor. The refinery treats the light fuel gas stream with the sour gas and the hydrogen sulfide at the sulfur recovery unit. Catalysts are cobalt or molybdenum oxides on alumina that might also contain nickel and tungsten; these are regenerated off site.

Alkylation forms a high octane gasoline blending stock (alkylates such as propane and butane) from isobutane. The isobutane feedstock is formed primarily during catalytic cracking and coking operations. The process uses either a sulfuric acid or hydrofluoric acid catalyst. A solution of potassium hydroxide is used to extract hydrofluoric acid catalyst from the hydrocarbon stream. Hydrofluoric acid might be regenerated on site, resulting in a waste oil containing dissolved polymerization products. The sulfuric acid must be regenerated in a sulfuric acid plant, usually located off site.

Polymerization (similar to alkylation) converts propene and butene to high octane gasoline blending stock using high pressure and a phosphoric acid catalyst. The catalyst is typically not regenerated. Prior to the reactor, the feedstock undergoes a caustic wash to remove mercaptans, which contain sulfur; an amine solution wash to remove hydrogen sulfide; a water wash to remove caustics and amines; and drying. Sulfur, bases, and oxygen can negatively impact the reaction. The wastewater generated includes caustic wash and sour water containing amines and mercaptans.

Isomerization alters the arrangement of the hydrocarbon molecules using high temperatures (200-400°F) and a platinum-based catalyst in a hydrogen environment. Typically, isomerization converts paraffins (butane or pentane) to isoparaffins with higher octane. Catalysts are replaced approximately every two to three years. The platinum in the spent catalyst is recovered off site. Sour gas and sour water are generated from the process.

One catalyst type requires the continuous addition of organic chlorides. The organic chlorides are converted to hydrogen chloride. The refinery uses caustic to neutralize any entrained hydrochloric acid in the light fuel gas stream. This results in a caustic wash waste stream, containing calcium chloride (or other salts).

7.3.3.3 Refining of Petroleum Fractions - Catalytic Reforming and Reformer Catalyst Regeneration

In December 1988, the Ontario Ministry of the Environment confirmed that dioxins were present in internal wastewater from Ontario petroleum refineries. The Ministry determined that catalyst regeneration operations for the catalytic reforming process were the source of the dioxins (24, Page G-1). Additional work by EPA confirmed that reformer catalyst regeneration wastewater was the major source of dioxins in refinery process wastewater (24).

Catalytic Reforming

Catalytic reforming units are designed to reform naphthas into higher octane aromatics, varying temperature and pressure to promote dehydrogenation, isomerization, and hydrogenolysis reactions.

The reforming process uses a platinum or bimetallic (platinum and rhenium) catalyst material. The catalyst is designed to be highly active and selective, and to promote dehydrogenation reactions with maximum surface area exposed to the feedstock. Ideally, the platinum ions are dispersed on the surface of an alumina or silica-alumina support. Chlorine promotes the activity of a platinum-alumina catalyst, and is stripped from the surface of the catalyst as hydrogen chloride during the reactions. As these reactions occur, the activity of the catalyst slows until it needs to be regenerated or replaced to be effective.

Dehydrogenation reactions are favored by low pressure and high temperature. However, coke is also formed at low pressure, which also tends to deactivate the catalyst and reduce yields. Coke formation can be reduced by operating under high hydrogen pressure.

Catalyst Regeneration

There are three general types of catalytic reforming processes, distinguished by the way in which catalyst is regenerated: semi-regenerative, cyclic, and continuous. A refinery might have more than one reformer, using different processes. Table 7-3 presents the number of refineries performing each type of regeneration. Because a refinery might have more than one reformer, using different processes, the sum of the refineries with each type of process exceeds the total number of refineries with catalytic reforming.

Table 7-3. Reformer Catalyst Regeneration Processes in 2000

Type of Regeneration Process	Number of Refineries	Percentage of Refineries With Catalytic Reforming
Semi-regenerative	33	27%
Cyclic	21	17%
Continuous	74	61%
Not specified	10	8%
Total	122	

Source: U.S. Department of Energy, *Petroleum Supply Annual 2000, Volume 1*. Energy Information Administration; and *Oil & Gas Journal*, "2001 Worldwide Refining Survey." Volume 99.52, December 24, 2001.

The following description of the three types of catalytic reforming processes is taken from Appendix G of the *1996 Preliminary Data Summary*.

The *semi-regenerative process* generally has three reactors. After the catalyst's activity is depleted, all three reactors are taken out of service and undergo one of several

regeneration processes. Figure 7-1 shows a typical schematic for this type of regeneration. In 2000, 27 percent of U.S. catalytic reforming units used the semi-regenerative process (20).

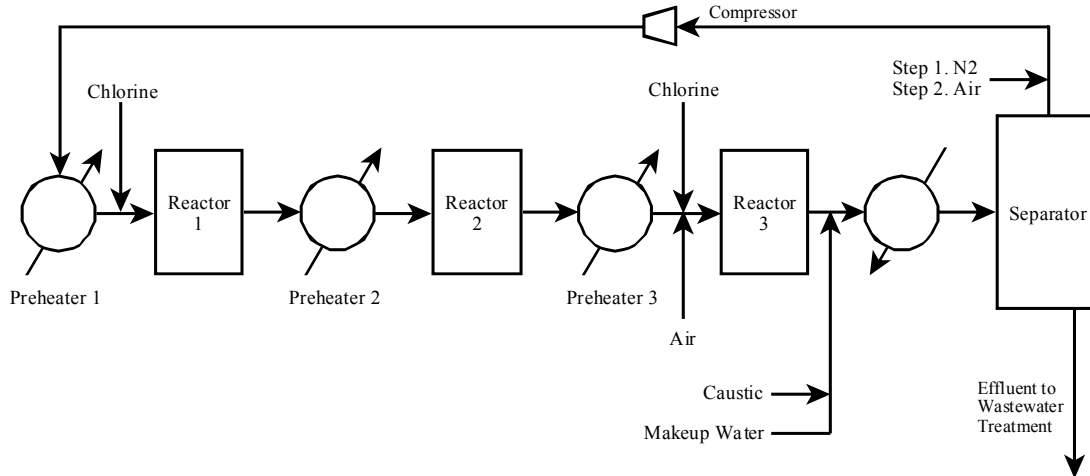

Figure 7-1. Semi-Regenerative Catalytic Reforming Process

The reactors are purged with nitrogen, the reactor bed temperature is raised to 750 to 850° F and the coke is burned off the catalyst with controlled oxygen concentration and pressures. Hydrogen chloride, chlorine, catalyst particles, carbon dioxide, oxides of sulfur and nitrogen, and organic compounds (including dioxins) might make up the composition of the off-gases. Scrubbing these acidic off-gases in the separator to neutralize the gases to protect the equipment generates wastewaters. Caustic or water might be used in scrubbing the off-gases, or, in some cases, the off-gases may be vented directly to the atmosphere. When the burn is complete, the catalyst is reactivated with either chlorine gas or chlorinated organic compounds.

The *cyclic catalytic reforming process* is similar to the semi-regenerative process except an additional reactor is available to replace one that is ready for regeneration. This allows for continued production during regeneration. While the semi-regenerative reformers are designed for long on-stream periods by using higher hydrogen pressure to reduce coke build-up, cyclic reformers are designed for lower operating pressure. Yields are much higher, but these cyclic reformers must be regenerated more frequently (daily to monthly). Figure 7-2 shows the regeneration process, which consists of the same operations as those used in the semi-regenerative process. In 2000, 17 percent of U.S. catalytic reforming units used the cyclic catalytic reforming process (20).

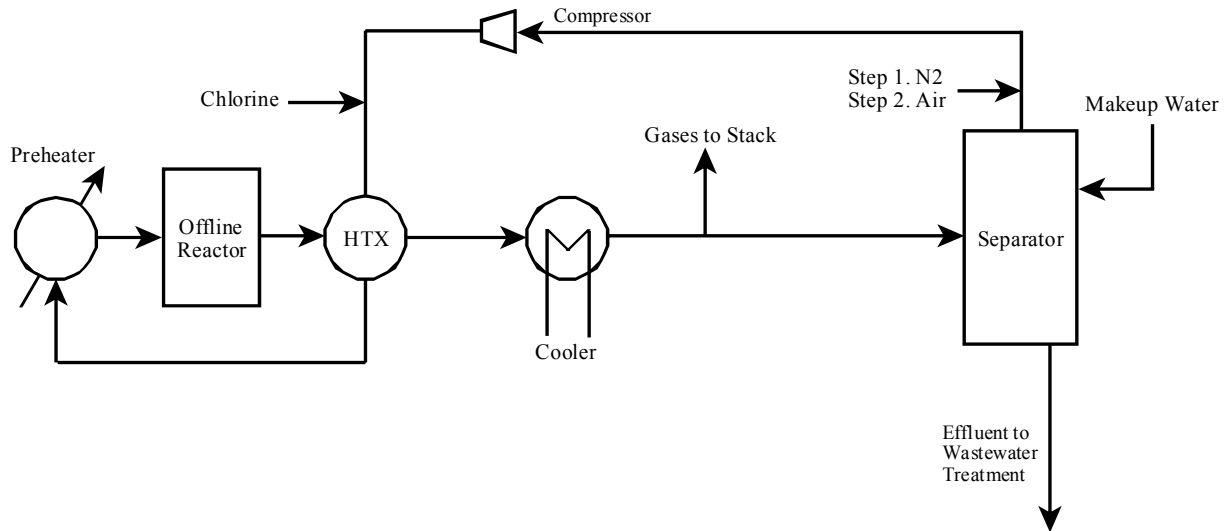

Figure 7-2. Cyclic Catalytic Reforming Process

The *continuous catalytic reforming process* is designed to operate at lower hydrogen pressures, which increases yield. However, operating at these low pressures results in more rapid coke buildup. To maintain performance, the unit is designed for continuous catalyst regeneration. Figure 7-3 shows a schematic of this process. In 2000, 61 percent of U.S. catalytic reforming units used the continuous process (20).

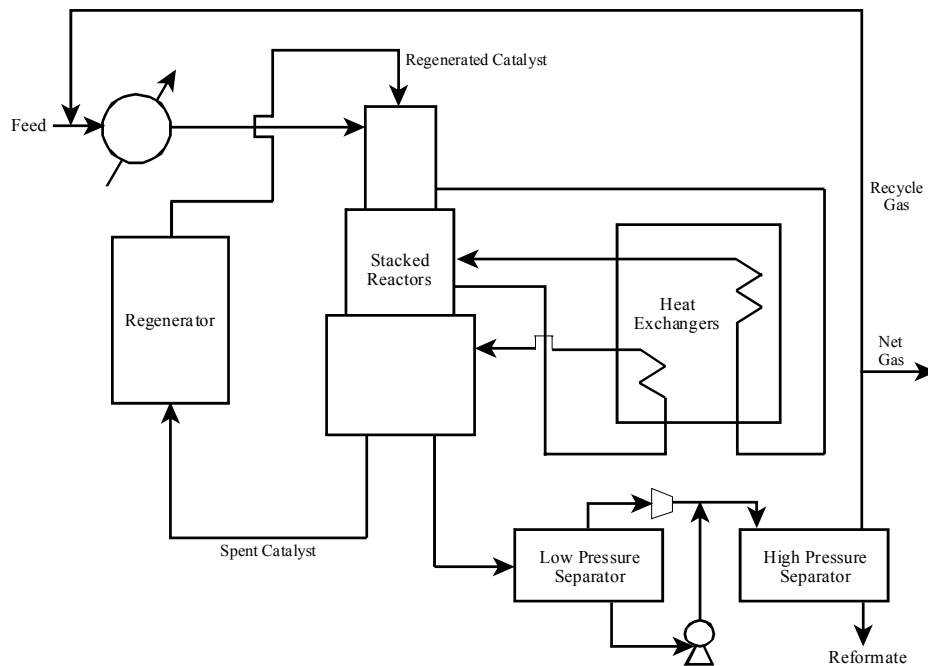

Figure 7-3. Continuous Catalytic Reforming Process

The only wastewater sources from the continuous reforming process are from scrubbing the off-gases; usually, the off-gases are vented and/or flared directly to the atmosphere. The regeneration off-gas vent might have a bag filter to capture catalyst fines, which are reprocessed to recover valuable catalyst material (platinum). In its 1990-91 study, EPA did not identify any facilities scrubbing off-gases from continuous regeneration reformers; therefore, the Agency did not include the continuous regeneration process in the wastewater sampling program.

7.3.3.4 Refining of Petroleum Product Properties

Petroleum refineries use further refining operations to enhance certain product properties. This subsection describes these operations (solvent extraction, chemical treating, dewaxing, and propane deasphalting).

To improve viscosity, oxidation resistance, color, and gum formation, refineries remove aromatics from the lube oil feedstock. **Solvent extraction** is the dissolving of the aromatics within a packed tower or rotating disc contactor, usually with furfural and phenol solvents. Solvents are recovered through distillation and steam stripping. The wastewater stream from the solvent recovery step contains oil and solvents.

To remove or modify properties associated with certain impurities (sulfur, nitrogen, or oxygen), refineries perform one of two **chemical treating** processes: 1) extraction or 2) oxidation (or sweetening). For example, refineries may remove sulfur, which gives the products an offensive odor. A possible waste stream is an oily disulfide stream.

To alter viscosity properties, refineries might dewax lubricating oil base stocks. **Dewaxing** processes include solvent dewaxing and selective hydrocracking. Solvents used include propane and mixtures of methyl ethyl ketone (MEK) with methyl isobutyl ketone (MIBK), or MEK with toluene. Wastewater is generated from solvent recovery. Selective hydrocracking uses one or two zeolite catalysts to selectively crack the wax paraffins. See Section 7.3.2.2 for more details on catalytic hydrocracking.

Propane deasphalting is an extraction process using propane to produce lubricating oil base stocks from vacuum distillation residuals. During propane recovery, wastewater contaminated with propane is produced.

7.3.3.5 Supporting Operations at Petroleum Refineries

Supporting operations at petroleum refineries include sulfur recovery, additive production, and product blending. Petroleum refineries recover sulfur from the sour gas to meet air emission limits of sulfur oxides (SO_x) and to sell elemental sulfur. Sulfur recovery includes the following steps: 1) separating fuel gases (methane and ethane) from the hydrogen sulfide and 2) removing sulfur from the hydrogen sulfide. To either improve performance or meet environmental requirements, refineries might produce additives for motor fuels, such as MTBE and tertiary amyl methyl ether (TAME). Product blending consists of mixing petroleum

products to meet customer specifications (e.g., vapor pressure, specific gravity, sulfur content, viscosity, octane rating).

7.4 Regulatory Background

Effluent limitations guidelines and pretreatment standards found in 40 CFR Part 419 are applicable to discharges from the petroleum refining industry. Sections 7.4.1 through 7.4.4 discuss these regulations in detail. In addition, Section 7.4.5 summarizes the Clean Water Act (CWA) stormwater requirements and Spill Prevention, Control, and Countermeasure (SPCC) requirements and two other major statutes with which petroleum refineries must comply: 1) the Resource Conservation and Recovery Act (RCRA) and 2) the Clean Air Act (CAA).

7.4.1 Effluent Guidelines History

In 1974, EPA promulgated standards for Best Practicable Control Technology Currently Available (BPT), Best Available Technology Economically Available (BAT), New Source Performance Standards (NSPS), Pretreatment Standards for Existing Sources (PSES) and Pretreatment Standards for Existing Sources (PSNS) for the Petroleum Refining category. BAT was remanded after legal challenge in 1976, and EPA continued to study BAT. This study included a survey of 1976 industry treatment practices. In 1982, EPA repromulgated BAT, setting it equal to BPT (i.e., the 1976 level of control). In 1985, EPA revised BAT for phenol and chromium, based on additional flow reduction and lower attainable concentrations for these two pollutants.

EPA conducted a review of the petroleum refining industry from 1992 to 1996 to determine whether revisions to the ELGs were warranted. For this evaluation, EPA reviewed data primarily from TRI and PCS. In addition, EPA collected sampling data during visits to six refineries. The Agency published the results of this review in the *Preliminary Data Summary for the Petroleum Refining Category*, April 1996 (24). The study provides a general description of the industry, treatment technologies used, water usage, analysis of dioxins in catalytic reformer wastewater, estimated pollutant discharges, environmental issues, and economic profile.

7.4.2 Subcategorization and Applicability

The effluent guidelines for the Petroleum Refining category are divided into five subcategories, described below:

- *Topping Refineries (Subcategory A)* - The effluent guidelines for this subcategory apply to discharges from any facility that produces petroleum products using topping and catalytic reforming, whether or not the facility includes any process in addition to topping and catalytic reforming. This subcategory does not apply to facilities that include thermal processes (coking, thermal cracking (visbreaking), etc.) or catalytic cracking. Topping refineries separate crude oil by atmospheric and/or vacuum distillation, solvent deasphalting, and catalytic reforming. Existing

guidelines for the topping subcategory include allowances for ballast water. Ballast is defined as the flow of waters, from a ship, that is treated along with refinery wastewaters in the main treatment system.

- *Cracking Refineries (Subcategory B)* - The effluent guidelines for this subcategory apply to all discharges from any facility that produces petroleum products using topping and cracking, whether or not the facility includes any process in addition to topping and cracking. However, this subcategory is not applicable to facilities that meet the definition of Subcategories C, D, or E.
- *Petrochemical Refineries (Subcategory C)* - The effluent guidelines for this subcategory apply to all discharges from any facility that produces petroleum products using topping, cracking, and petrochemical operations whether or not the facility includes any process in addition to topping, cracking, and petrochemical operations. However, this subcategory is not applicable to facilities that meet the definition of Subcategories D or E. Petrochemical operations meet one of the two following definitions:
 - Produce of second-generation petrochemicals (e.g., alcohols, ketones, cumene, and styrene), or
 - Produce of first-generation petrochemicals and isomerization products (e.g., benzene, toluene, xylenes, olefins, and cyclohexane) when 15 percent or more of the total refinery production is as first-generation petrochemicals and isomerization products.
- *Lube Refineries (Subcategory D)* - The effluent guidelines for this subcategory apply to all discharges from any facility that produces petroleum products using topping, cracking, and lube oil manufacturing processes, whether or not the facility includes any process in addition to topping, cracking, and lube oil manufacturing processes. However, this subcategory is not applicable to facilities that meet the definition of Subcategories C or E.
- *Integrated Refineries (Subcategory E)* - The effluent guidelines for this subcategory apply to all discharges resulting from any facility that produces petroleum products using topping, cracking, lube oil manufacturing processes, and petrochemical operations, whether or not the facility includes any process in addition to topping, cracking, lube oil manufacturing processes, and petrochemical operations.

7.4.3 Technical Basis of Regulation

The BPT basis includes the following in-plant controls:

- Sour water strippers to reduce sulfide and ammonia entering the wastewater treatment plant;
- Elimination of once-through barometric condenser water;
- Sewer segregation, to keep unpolluted stormwater run-off and once-through cooling water separate from process wastewater (and out of the wastewater treatment plant); and
- Elimination of polluted once-through cooling water by properly maintaining surface condensers or using wet and dry recycle systems.

The BPT and NSPS basis includes the following end-of-pipe treatment:

- Equalization and stormwater diversion;
- Oil and solids removal (API separator and/or baffle plate separator);
- Dissolved air flotation (DAF) to remove additional oil;
- Biological treatment to reduce biochemical oxygen demand (BOD) and chemical oxygen demand (COD) (activated sludge, aerated lagoons, oxidation ponds, or trickling filter); and
- Effluent polishing (polishing ponds or sand, dual-media, or multimedia filters).

In 1982, EPA confirmed the above technology basis for setting BAT effluent limitations. EPA based PSES and PSNS on oil/water gravity separators and in-plant sour water stripping for ammonia control.

7.4.4 Regulated Pollutants

BPT, BAT, and NSPS established production-based mass limitations for the following pollutants based on the treatment technologies described in Section 7.4.3:

- Ammonia as nitrogen;
- 5-day BOD;
- COD (or total organic compounds (TOC) for high-chloride effluents);
- Hexavalent chromium;
- Oil and grease;

- pH;
- Phenolic compounds;
- Sulfide;
- Total chromium; and
- Total suspended solids (TSS).

In 1982, EPA used new data to revise its BAT flow model and developed more stringent limitations for chromium and total phenolics. The limitations for these pollutants are listed in 40 CFR Part 419. The mass limitations are based on feedstock production (pounds pollutant per 1,000 barrel feedstock), and specific refinery limitations are based on size factors (1,000 barrels feedstock per stream day), process configuration factors, and processes.

EPA established the following daily maximum pretreatment standards for existing sources in all subcategories:

- Oil and grease: 100 milligrams per liter (mg/L); and
- Ammonia as nitrogen: 100 mg/L.

EPA established the following daily maximum pretreatment standards for new sources in all subcategories:

- Oil and grease: 100 mg/L;
- Ammonia as nitrogen: 100 mg/L; and
- Total chromium for cooling tower discharge: 1 mg/L.

7.4.5 Other Regulations Affecting Petroleum Refineries

In addition to the effluent limitations guidelines and standards at 40 CFR Part 419, petroleum refineries are also subject to other regulations. This subsection describes a few of the major regulations also affecting the petroleum refining industry. These include solid and hazardous waste regulations (RCRA), hazardous air pollutant regulations (CAA), and CWA stormwater regulations and SPCC requirements.

7.4.5.1 RCRA

RCRA addresses solid (Subtitle D) and hazardous (Subtitle C) waste management activities. Subtitle C (40 CFR Parts 260-299) governs the handling of hazardous waste from the point of generation to disposal. Regulations for hazardous waste include waste accumulation, manifesting, and record-keeping standards. Permits under Subtitle C include facility contingency plans, emergency procedures, and unit-specific standards. Petroleum refineries typically generate the following listed and characteristic hazardous wastes:

- K051 - API separator sludge;
- K049 - Slop oil emulsion solids;
- K048 - Dissolved air flotation floats;

- F037 - Other primary oil/water separator sludge, bar screen debris;
- F038 - All other sludge, floats, and used filter bags;
- D004 - Wastes containing arsenic;
- D007 - Wastes containing chromium;
- D008 - Wastes containing lead;
- D009 - Wastes containing mercury; and
- D010 - Wastes containing selenium.

To meet land disposal restrictions, facilities typically incinerate these wastes.

7.4.5.2 CAA National Emission Standards for Hazardous Air Pollutants (NESHAPs)

Refineries are subject to NESHAP if they are a major source of hazardous air pollutants (HAP) and emit 10 tons per year of a single HAP or 25 tons per year of a combination of HAPs. The 1995 Petroleum Refinery NESHAP requires controls for wastewater streams containing benzene above specified threshold amounts (e.g., 10 parts per million (ppm) by weight). By August 1998, refineries were required to comply with the benzene NESHAP 40 CFR Part 61 Subpart FF, which requires reducing benzene mass emissions by 99 percent using suppression followed by another treatment process (e.g., steam stripping or biotreatment); **and** reducing emissions from vents from stream strippers, other waste management, or treatment units by 95 percent with a control device or to 20 ppm (by volume) at the outlet of the control device. Suppression includes “hard piping” and using enclosed tanks and oil/water separators, vented to vapor collection.

7.4.5.3 Other CWA Requirements

Under the CWA, EPA developed stormwater regulations to control the discharge of stormwater associated with an industrial activity (i.e., stormwater discharge directly related to manufacturing, processing, or raw material storage areas) (40 CFR Part 122.26(b)(14)). These regulations apply to stormwater from Category ii - Manufacturing, one of the 11 industrial activity categories defined at 40 CFR Part 122.26. This category specifically lists facilities classified as SIC code 29, which includes petroleum refineries.

The stormwater regulations require regulated refineries to obtain coverage under a NPDES stormwater permit and implement stormwater pollution prevention plans (SWPPPs) or stormwater management programs to effectively reduce or prevent the discharge of pollutants into receiving waters. Both the SWPPPs and stormwater management programs use best management practices (BMPs).

The SPCC requirements were also developed under the CWA. SPCC requires refineries meeting applicability requirements to prepare and implement spill prevention plans to avoid oil spills into navigable waters or adjoining shorelines of the United States. The SPCC plan must identify operating procedures in place and control measures installed to prevent oil spills, and countermeasures to contain, clean up, or mitigate the effects of any oil spills that occur.

7.5 Wastewater Characterization

As detailed in the U.S. Department of Energy's *Water Use in Industries of the Future: Petroleum Industry*, the petroleum refining industry consumes approximately 65 to 90 gallons of water for every barrel of crude petroleum it refines. Most of this water is used for steam production and cooling towers. Approximately 10 percent of this supply water (plus additional blowdown flows from the steam production and cooling tower systems) is used for process units, where it might be contaminated with pollutants (22). The process water is either evaporated or treated (on or off site) as wastewater. This section describes the wastewater generated, treated, and discharged from the petroleum refining industry, including wastewater sources, types of pollutants, treatment, discharge volumes, and pollutant loadings.

7.5.1 Wastewater Sources

The major wastewaters from petroleum refineries are sour water from multiple processes, scrubber water from reformer catalyst regeneration, spent potassium hydroxide stream from alkylation, desalting wastewater, and caustic wash water from isomerization. Table 7-4 lists the major refining processes, types of wastewaters, and wastewater flow estimates as reported in the U.S. DOE's *Water Use in Industries of the Future: Petroleum Industry*. The table does not include the following wastewaters (described below):

Reformer Catalyst Regeneration Wash Water - Regeneration of spent catalyst from the reforming process is a potential source of dioxins. Catalyst burning generates dioxins (along with other combustion products). In addition to dioxins, the off-gases from the regeneration reactor contain hydrogen chloride, chlorine, catalyst particles, carbon dioxide, sulfur oxides, nitrogen compounds, and organic compounds. A caustic or water wash neutralizes the acidic off-gases (i.e., scrubs the off-gas). Some refineries directly vent the off-gases to the atmosphere. The wash stream is recycled with a blowdown of spent caustic (24). As shown in Table 7-20, the volume of wastewater generated during catalyst regeneration at three Washington State refineries ranged from 2,200 to 360,000 gallons per cycle.

Quench Wastewater - Petroleum refineries use direct contact "quench" water to cool products quickly. The quench water is recirculated, and to maintain water quality, a blowdown stream is sent to wastewater treatment (22).

Leaks - Includes any cooling water leaking into the hydrocarbon stream of the heat exchanger (22).

Table 7-4. Process Wastewater at Petroleum Refineries

Process	Wastewater Description (Possible Pollutants)	Wastewater Flow Rate (gallon/barrel of crude petroleum)	Percentage of Total Wastewater Flow Rate
Distillation	Sour water (hydrogen sulfide, ammonia, suspended solids, chlorides, mercaptans, and phenol)	26.0	44%
Fluid catalytic cracking	Sour water (hydrogen sulfide, ammonia, suspended solids, oil, phenols, and cyanides)	15.0	26%
Catalytic reforming	Sour water (hydrogen sulfide, ammonia, suspended solids, mercaptans, oil) ¹	6.0	10%
Alkylation	Spent potassium hydroxide stream (hydrofluoric acid)	2.6	4%
Crude desalting	Desalting wastewater (salts, metals, solids, hydrogen sulfide, ammonia, and phenol)	2.1	4%
Thermal cracking/Visbreaking	Sour water (hydrogen sulfide, ammonia, suspended solids, dissolved solids, and phenol)	2.0	3%
Catalytic hydrocracking	Sour water (hydrogen sulfide, ammonia, and suspended solids)	2.0	3%
Coking ²	Sour water (hydrogen sulfide, ammonia, and suspended solids)	1.0	2%
Isomerization	Sour water (hydrogen sulfide and ammonia) and caustic wash water (calcium chloride or other chloride salts)	1.0	2%
Additive production: ethers manufacture	Pretreatment wash water (nitrogen contaminants)	<1.0	
Catalytic hydrotreating	Sour water (hydrogen sulfide, ammonia, suspended solids, and phenol)	1.0	2%
Chemical treating: sweetening/Merox process		³	
Sulfur removal/Claus process	Sour water (hydrogen sulfide and ammonia)	<1.0	
Lubricating oil manufacture	Steam stripping wastewater (oil and solvents) and solvent recovery wastewater (oil and propane)	<1.0	
TOTAL		58.7	100%

Source: U.S. DOE. *Water Use in Industries of the Future: Petroleum Industry*. July 2003.

¹Additional pollutants identified in EPA's *Industry Sector Notebook: Petroleum Refining*, September 1995.

²Fluid coking produces little or no effluents.

³Little or no wastewater generated.

7.5.2 Discharge Volumes

7.5.2.1 Discharge Volumes from the 1996 Preliminary Data Summary

Refinery process wastewater flow rates reported in EPA's 1996 *Preliminary Data Summary* range from 0.4 to 8.1 million gallons per day (MGD) (150 to 3,000 million gallons per year (MGY)). The median flow rate for a refinery was 1.5 MGD (average: 2.3 MGD). (24)

7.5.2.2 Discharge Volumes from All Refineries Reported to 2000 PCS

EPA reviewed the discharge volumes from all refineries reported to PCS in 2000; however, the total flow rates reported to PCS might include stormwater and noncontact cooling water, as well as process wastewater. In some cases, the PCS database identifies the type of wastewater being discharged; however, most reported flow rates do not indicate the type of wastewater. Total wastewater flow rates reported to PCS in 2000 range from 0.15 to 1,240 MGD (54 to 454,000 MGY). The median flow rate was 4.26 MGD (1,560 MGY) (34).

To isolate the process wastewater flow rate in the values reported to PCS, EPA calculated the refinery discharge volume for only those outfalls where the refinery must monitor for five-day BOD (BOD₅). Refinery permits include limitations for BOD₅ and/or ammonia for process wastewater, but not for stormwater or noncontact cooling water. EPA calculated the wastewater flow rates from outfalls with nonzero discharges of BOD₅ or ammonia. These flow rates range from 0.09 to 1,240 MGD (33 to 454,000 million gallons per year). The median flow rate is 2.1 MGD (765 million gallons per year) (34). These flows are significantly greater than the range and median refinery wastewater flow rates reported in the *1996 Preliminary Data Summary*. Since EPA has not received or obtained any information during this detailed review to indicate process flows have increased since the *1996 Preliminary Data Summary*, EPA concludes that the higher volumes reflect EPA's inability to completely distinguish between process wastewater discharges and nonprocess wastewater discharges in PCS.

7.5.3 Pollutant Loadings

For its screening-level analysis, EPA estimated current discharges (as TWPE) to surface water from 56 industries currently covered by existing effluent guidelines. EPA used data reported to TRI and PCS to estimate direct discharges, and used data reported to TRI, reduced by a typical POTW percent removal, to estimate indirect discharges. EPA applied TWFs to the TRI and PCS data to calculate the TWPE for each pollutant reported discharged by petroleum refineries. The petroleum refining industry ranked fourth in pollutant discharges based on 2000 TRI data and fourteenth in pollutant discharges based on 2000 PCS data. See the Federal Register notice on the December 31, 2003 Preliminary Effluent Guidelines Program Plan, FRN [FRL-7604-7]. See 4.2.4 for more discussion of EPA's calculation of TWPE.

Based on further review of the available data for this detailed study and comments submitted in response to the December 31, 2003 Federal Register notice on the Preliminary Effluent Guidelines Program Plan, EPA revised the list of refineries, the calculation of PACs and

dioxin TWPEs, and estimates of the current discharges to surface water from the petroleum refining industry. EPA used these pollutant loadings to compare the Petroleum Refining category to other industrial point source categories, and identify trends in wastewater discharges.

7.5.3.1 Pollutant Loadings Calculated Using TRI Data

Refineries report both direct discharges (i.e., mass of pollutant released directly to receiving streams) and indirect discharges before treatment (i.e., mass of pollutant transferred to POTWs) to TRI. For direct discharges, EPA used the reported mass to calculate TWPEs. For indirect discharges, EPA first estimated pollutant mass removed by the POTW (i.e., pollutant percent removal) and then used the resulting mass of pollutant after treatment to calculate TWPEs discharged to the POTW's receiving stream. EPA calculated the reduction in pollutant mass for indirect discharges using average POTW removal efficiencies (see DCN 00618, *Evaluation of RSEI Model Runs*).

Using data as reported to TRI in 2000, the reported releases of PACs, dioxins, and metals (predominantly vanadium) comprise 90 percent of the petroleum refining industry's toxic releases. Refineries reporting to TRI discharge 328,000 TWPEs. Table 7-5 presents the pounds (and TWPE) discharged by direct and indirect dischargers as reported to TRI for dioxins, PACs, and metals.

Table 7-5. Discharges Reported to the 2000 TRI for the Petroleum Refining Industry - Pollutants Comprising Approximately 90 Percent of the TWPE

Pollutant	Total Pounds Discharged	Total TWPE Discharged	Percentage of Total TWPE Discharged	TWPE Range per Reporting Refinery	Average TWPE per Reporting Refinery	Number of Reporting Refineries
Dioxins ¹	0.02	139,000	37%	42 - 52,000	8,200	17
PACs ²	487	112,000	30%	460 - 40,400	5,900	19
Metals (Top 5) ³ (Vanadium Only)	98,200	76,000 (55,000)	20% (15%)	0.96 - 25,076 (3.7 - 25,076)	1316 (3,946)	42 (14)
TOTAL	139,000	328,000	87%			53

Source: *TRI Releases 2000*.

¹See Section 7.7.2 for a discussion on the calculation of TWPE.

²See Section 7.6.2 for a discussion on the calculation of TWPE.

³Top 5 metals include: vanadium, mercury, selenium, chromium, and lead.

EPA reviewed whether stormwater discharges are commonly reported to TRI. When reporting discharges to surface water for TRI, facilities may report the percentage of the pollutant discharge attributed to stormwater. Based on a review of the data reported to the 2000 TRI, all reported discharges of dioxins and PACs are from process wastewater (not stormwater). Most vanadium discharges are also from process wastewater. Table 7-6 presents the stormwater data reported to the 2000 TRI for petroleum refining.

Table 7-6. Stormwater Discharges Reported to the 2000 TRI

Pollutant	Number of Refineries Reporting Pollutant	Number of Refineries Reporting Percent Stormwater for Direct Discharges	Number of Refineries Reporting All Discharges as Process Wastewater (0 Percent Stormwater)
Dioxins	17	7	7
PACs	19	14	14
Vanadium	14	8	7

Source: *TRIRelases2000*.

7.5.3.2 Pollutant Loadings Calculated Using PCS Data

Refineries report direct discharges to PCS. For direct discharges, EPA used the reported mass to calculate TWPEs. As discussed in Section 7.2.2, PCS includes only results of permit-required monitoring for direct discharging facilities. Even though toxic pollutants may be present in a refinery's discharge, they will not be reported unless required by permit.

Using PCS data, the reported releases of sulfide comprise over 50 percent of the petroleum refinery industry's toxic releases. Refineries reporting to PCS discharge 193,000 TPWEs. PCS has little discharge data for PACs and dioxins, and sulfide is not reportable to TRI. Table 7-7 presents the pounds (and TWPE) discharged by direct dischargers as reported to PCS for the 10 most toxic discharged pollutants (by TWPE). These pollutants compose over 90 percent of the total industry TWPE.

Table 7-7. Discharges Reported to the 2000 PCS for the Petroleum Refining Industry - Top 10 Pollutants Composing 91 Percent of the TWPE

Pollutant	Total Pounds Discharged	Total TWPE Discharged	Percentage of Total TWPE Discharged	TWPE Range per Reporting Refinery	Median TWPE per Reporting Refinery	Number of Reporting Refineries
Sulfide, Total ¹	35,969	100,734	52%	3 - 12341	521	70
Chlorine, Total Residual ²	52,069	25,357	13%	14 - 12323	130	13
Fluoride, Total (as F)	462,807	16,198	8%	8 - 6069	1092	11
Selenium, Total (as Se)	7,856	8,802	4%	1 - 3291	303	13
Aluminum, Total (as AL)	120,235	7,754	4%	64 - 7115	241	5
Phenolics, Total Recoverable	261,985	7,336	4%	0.07 - 6954	2	68
Arsenic, Total (as As)	1,277	4,430	2%	4 - 2122	257	7
Nitrogen, Ammonia Total (as N)	1,917,492	3,509	2%	0.16 - 772	14	86
Cyanide, Total (as CN)	1,956	2,107	1%	3 - 801	89	10

Table 7-7 (Continued)

Pollutant	Total Pounds Discharged	Total TWPE Discharged	Percentage of Total TWPE Discharged	TWPE Range per Reporting Refinery	Median TWPE per Reporting Refinery	Number of Reporting Refineries
Mercury, Total (as Hg)	16	1,908	1%	10 - 1685	32	7
Total PCS Pollutants³	331,931,974	192,862				104

Source: *PCSLoads2000*.

¹Includes Sulfide Total (as Sulfur).

²Total residual chlorine is often reported as a maximum value. Pollutant loadings may be overestimated.

³Total includes all pollutants reported to PCS, including BOD₅ and TSS, which do not have TWFs and do not contribute to the TWPE.

7.5.4 Treatment In Place

Petroleum refineries treating process wastewater on site typically use the following technologies:

- Steam stripping to remove hydrogen sulfide, other sulfur compounds, and ammonia for sour water pretreatment;
- Oil and solids separation using API separator, corrugated plate interceptor, or other type of separator followed by DAF or settling ponds to remove emulsified oils;
- Biological treatment via activated sludge units, trickling filters, or rotating biological contactors; and
- Polishing the effluent via activated carbon, anthracite coal, or sand filters.

Indirect dischargers typically separate the oil and solids and then discharge the wastewater to a POTW.

Facilities reporting TRI releases also provide information on their wastewater treatment operations. Table 7-8 lists the treatment processes used by petroleum refineries as reported to the 2000 TRI.

Table 7-8. Wastewater Treatment Operations Reported By Petroleum Refineries, TRI Reporting Year 2000

Wastewater Treatment Technology	Number of Refineries Reporting Use	
	Direct ¹ (93 refineries)	Indirect ¹ (18 refineries)
Steam stripping - in-process treatment that removes ammonia and mercaptans from sour waters.	30	6
API separator - operated for oil recovery. Considered process step. Separator effluent is the influent to the end-of-pipe wastewater treatment (count is for P15 oil skimming).	86	23
Dissolved air flotation - removes oils and particulate material prior to biological treatment. DAF float is a listed hazardous waste.	66	17
Biological treatment - most refineries use aerobic biological treatment (activated sludge or aerated basins) to reduce wastewater organic carbon (BOD and COD) load. Biological treatment can also remove phenolic compounds.	100 ¹	9
Sedimentation - always follows activated sludge basins. Separate clarification might also follow aerated basins (count is for P11 settling/clarification).	78	13
Polishing - sand, dual media, or multimedia filtration removes fine particulate (count is for P12 filtration).	33	6
Activated carbon adsorption - removes soluble organic material and some metals.	14	1

Source: *TRIRelases2000*.

¹In *TRIRelases2000*, of the refineries that provided information on their wastewater treatment operations, 93 reported direct releases, 18 reported transfers to POTWs, and 9 reported both direct releases and transfers to POTWs. Therefore, the total refineries reporting a treatment technology might exceed the total number of direct or indirect dischargers.

7.6 Polycyclic Aromatic Compounds

PACs, sometimes known as polycyclic aromatic hydrocarbons (PAHs), are a class of organic compounds consisting of two or more fused aromatic rings. This section includes the following subsections:

- Section 7.6.1 - Identification and description of PACs;
- Section 7.6.2 - Estimation of TWPE for petroleum refineries;
- Section 7.6.3 - PAC sources at petroleum refineries;
- Section 7.6.4 - Reported PAC discharges;

- Section 7.6.5 - Further analysis of PACs (including release estimation methods for TRI reporting and PAC concentrations in refinery final effluents);
- Section 7.6.6 - PAC control technologies; and
- Section 7.6.7 - Detailed study findings on PACs.

7.6.1 Identification and Description of PACs

Table 7-9 lists the 21 individual compounds in the PAC category for TRI reporting, Chemical Abstract Service (CAS) number, and related data.

Table 7-9. Individual Polycyclic Aromatic Compounds

PAC Compound	CAS Number	Toxic Weighting Factor	Potential Carcinogen? ¹	Priority Pollutant?	Properties ²
Benzo(a)anthracene	56-55-3	180.9752	✓	✓	Solubility: 0.0000014 g/100 mL Partition Coefficient: 5.61
Benzo(a)phenanthrene (chrysene)	218-01-9	2.1038		✓	Solubility: 0.00000018 g/100 mL
Benzo(a)pyrene	50-32-8	4283.5600	✓	✓	Solubility: 0.00000038 g/100 mL Partition Coefficient: 6.04
Benzo(b)fluoranthene	205-99-2	421.3560	✓	✓	Solubility: 0.00000012 g/100 mL Partition Coefficient: 6.12
Benzo(j)fluoranthene	205-82-3		✓		
Benzo(k)fluoranthene	207-08-9	42.1356	✓	✓	Solubility: 0.000000055 g/100 mL Partition Coefficient: 6.84
Benzo(j,k)fluorene (fluoranthene)	206-44-0	0.8030		✓	Solubility: 0.0000265 g/100 mL
Benzo(r,s,t)pentaphene	189-55-9		✓		
Dibenz(a,h)acridine	226-36-8		✓		
Dibenz(a,j)acridine	224-42-0		✓		
Dibenzo(a,h)anthracene	53-70-3	1693.0160	✓	✓	Solubility: 0.00000005 g/100 mL Partition Coefficient: 6.5
Dibenzo(a,e)fluoranthene	5385-75-1				
Dibenzo(a,e)pyrene	192-65-4		✓		
Dibenzo(a,h)pyrene	189-64-0		✓		
Dibenzo(a,l)pyrene	191-30-0		✓		
7H-Dibenzo(e,g)carbazole	194-59-2		✓		
7,12-Dimethylbenz(a)anthracene	57-97-6				Solubility: <0.1 g/100 mL at 18 C
Indeno(1,2,3-cd)pyrene	193-39-5	1.1388	✓	✓	Solubility: 0.0000062 g/100 mL Partition Coefficient: 6.58

Table 7-9 (Continued)

PAC Compound	CAS Number	Toxic Weighting Factor	Potential Carcinogen? ¹	Priority Pollutant?	Properties ²
3-Methylcholanthrene	56-49-5				Solubility: <0.01 g/100 mL at 18
5-Methylchrysene	3697-24-3		✓		
1-Nitropyrene	5522-43-0				Solubility: <0.1 g/100 mL at 18 C

¹Source: U.S. Department of Health and Human Services. *Report on Carcinogens, Tenth Edition*. Public Health Service, National Toxicology Program, December 2002.

²For comparison, benzene's solubility is 0.18 g/100 mL and partition coefficient is 2.13.

The partition coefficient is presented as log K_{ow} .

Source for solubilities: <http://www.chemfinder.com>.

7.6.2 Estimation of TWPE

For TRI, facilities must report the combined mass of PACs released, not releases of individual compounds. To calculate the TWPE for PAC discharges, EPA developed a refinery-specific PAC TWF based on the concentration of individual PACs in petroleum products and amount of products. The calculated TWF equals 230.43. See the *Memorandum: Toxic Weighting Factor for Petroleum Refining Polycyclic Aromatic Compounds*, 12/11/2003, DCN 00646 for further details (33).

Some petroleum refineries are required to report the discharge of individual PACs as a condition of their NPDES permits. These reported discharges are included in the PCS database. In these cases, EPA used the TWFs for the individual PACs to calculate their TWPE. Petroleum refineries are also sometimes required by permit to report discharges of "Polynuclear Aromatic Hydrocarbons per Method 610." Method 610 is a wastewater analytical method for 16 compounds, eight of which are included on the TRI list of PACs. EPA does not have a TWF for PAHs, and therefore did not include Method 610 discharges in the TWPE calculation.

7.6.3 Sources at Petroleum Refineries

PACs are likely present in petroleum products such as crude oil, fuel oil, diesel fuel, gasoline, and paving asphalt (bituminous concrete) and refining by-products such as heavy oils, crude tars, and other residues. PAHs form due to incomplete combustion of organic compounds. PACs might be generated during the production of synthetic fuels and products from coal, petroleum, and other feedstocks at refineries (23, 30). Refinery process sources of PACs include cracking operations (thermal and catalytic) and crude petroleum storage when refineries remove PAC-containing water from tanks (37). Table 7-10 lists individual PACs and sources from petroleum refinery operations.

Table 7-10. Individual PACs and Petroleum Refinery Sources

PAC Compound	CAS Number	Sources at Petroleum Refineries
Benzo(a)anthracene	56-55-3	Product of incomplete combustion; fossil fuels
Benzo(a)phenanthrene (chrysene)	218-01-9	Product of incomplete combustion; fossil fuels; coke plant exhaust
Benzo(a)pyrene	50-32-8	Product of incomplete combustion; fossil fuels; coal tar; municipal incinerator emissions
Benzo(b)fluoranthene	205-99-2	Product of incomplete combustion; fossil fuels
Benzo(j)fluoranthene	205-82-3	Product of incomplete combustion; fossil fuels; coal tar
Benzo(k)fluoranthene	207-08-9	Product of incomplete combustion; fossil fuels; coal tar; lubricating oils, crude oils
Benzo(j,k)fluorene (fluoranthene)	206-44-0	Product of incomplete combustion; fossil fuels; coal tar
Benzo(r,s,t)pentaphene	189-55-9	Product of incomplete combustion; fossil fuels; coal tar
Dibenz(a,h)acridine	226-36-8	Product of incomplete combustion (particularly coal burning processes)
Dibenz(a,j)acridine	224-42-0	Product of incomplete combustion (particularly coal burning processes); petroleum refinery incinerator effluents
Dibenzo(a,h)anthracene	53-70-3	Product of incomplete combustion; fossil fuels; coal tar; gasoline engine exhaust tar
Dibenzo(a,e)fluoranthene	5385-75-1	Product of incomplete combustion
Dibenzo(a,e)pyrene	192-65-4	Product of incomplete combustion; fossil fuels
Dibenzo(a,h)pyrene	189-64-0	Product of incomplete combustion; fossil fuels; coal tar
Dibenzo(a,l)pyrene	191-30-0	Product of incomplete combustion; fossil fuels; coal gasification
7H-Dibenzo(e,g)carbazole	194-59-2	Coal burning processes; coal tar and coal distillates
7,12-Dimethylbenz(a)anthracene	57-97-6	Produced in small quantities as a research chemical, not formed during combustion
Indeno(1,2,3-cd)pyrene	193-39-5	Product of incomplete combustion; fossil fuels; coal tar; petroleum asphalt
3-Methylcholanthrene	56-49-5	Produced in small quantities as a research chemical, not formed during combustion
5-Methylchrysene	3697-24-3	Product of incomplete combustion; crude oil
1-Nitropyrene	5522-43-0	Diesel and gasoline engines; coal fired energy conversion plants; aluminum smelter stack gases

Sources: U.S. Department of Health and Human Services, *Report on Carcinogens, Tenth Edition*, Public Health Service, National Toxicology Program, December 2002. and D. Aronson and P.H. Howard, *Sources of Individual PAHs Listed in the PBT Chemical Pool*, January 2000 (as listed in U.S. EPA, *Emergency Planning and Community Right-to-Know Act - Section 313: Guidance for Reporting Toxic Chemicals: Polycyclic Aromatic Compounds Category*, EPA 260-B-01-03, August 2001.

7.6.4 Reported PAC Discharges

The estimated PACs loadings for the petroleum refining industry are based on data as reported to TRI for 2000. Nineteen refineries² reported wastewater releases of PACs to TRI. Seven refineries reported discharges of individual PACs to PCS, but none of them reported detecting concentrations above analytical detection limits. As stated in Section 7.2.1, 94 percent of the refineries report to TRI; however, refineries report the releases of PACs only if they exceed the reporting threshold. Refineries report PAC discharges to PCS only if required by their permits. This subsection discusses the following:

- Section 7.6.4.1 - TRI discharges reported by petroleum refineries;
- Section 7.6.4.2 - PCS discharges reported by petroleum refineries; and
- Section 7.6.4.3 - PAC data, including measurement data from activated sludge units and POTW final effluents, provided in comments regarding the Preliminary Plan.

7.6.4.1 TRI Discharges

As noted in Section 7.6.2, refineries report PAC discharges as a total category amount, not by individual compound. Table 7-11 presents the data reported to TRI and the calculated TWPE. Note that current guidance for reporting to TRI suggests using one-half the detection limit to estimate releases based on “nondetects”; therefore, the total discharges may be overestimated. This is confirmed by discussions with staff from EPA’s Office of Environmental Information (16) and comments from API and NPRA (1, 11).

7.6.4.2 PCS Discharges

For six California refineries, listed in Table 7-12, discharges of PAHs were included in PCS (see discussion in Section 7.6.2). For two of these six refineries, reported PAH concentrations were above the method detection limit. Because EPA does not have a TWF for this parameter, it did not calculate TWPEs for these discharges.

In addition, American Western Refining, Lawrenceville IL (NPDES IL0004219), is required to report polynuclear aromatics (polyram), but did not detect the pollutant in 2000.

²Two additional refineries, Calcasieu (Lake Charles, LA) and Frontier (El Dorado, KS) each reported releases to surface water of 1.1 pounds of PACs in 2000. However, these refinery releases were not included in *TRIRelases2000*.

Table 7-11. Petroleum Refineries Reporting Releases of PACs to the 2000 TRI¹

TRI ID Number	Refinery	Refinery Location	Direct Discharge (lb/yr)	Direct Discharge (TWPE)	To POTW (lb/yr)	After POTW (lb/yr) ²	After POTW (TWPE)
77592TXSCTLOOP1	Valero Refining Co. Texas	Texas City, TX	64	14,748	--	--	--
94572NCLSNOLDHI	Tosco San Francisco Refinery	Rodeo, CA	57	13,135	--	--	--
70037LLNCRHIGHW	Tosco Refining Co. Alliance Refinery	Belle Chasse, LA	40	9,217	--	--	--
70669CNCLKOLDSP	Conoco Lake Charles Refinery	Westlake, LA	22	5,069	--	--	--
96707CHVRN91480	Chevron Prods. Co. Hawaii Refinery	Kapolei, HI	20	4,609	--	--	--
99611TSRLSMILE2	Tesoro Alaska Co. Kenai Refinery	Kenai, AK	19	4,378	--	--	--
39567CHVRNPOBOX	Chevron Prods. Co. Pascagoula Refinery	Pascagoula, MS	17	3,917	--	--	--
62454MRTHNMARAT	Marathon Ashland Petroleum LLC	Robinson, IL	15	3,456	--	--	--
62084SHLLLRTE11	Tosco Wood River Refinery	Roxana, IL	10	2,304	--	--	--
74603CNCNP1000S	Conoco Inc. Ponca City Refinery	Ponca City, OK	9	2,074	--	--	--
84116CHVRN2351N	Chevron USA Prods. Co	Salt Lake City, UT	8	1,843	--	--	--
80022CNCNDN5801B	Conoco Denver Refinery	Commerce City, CO	5	1,152	--	--	--
70047TRNSM14902	Orion Refining Corp.	New Sarpy, LA	4	922	--	--	--
90744TXCRF2101E	Equilon Enterprises LLC Los Angeles Refining	Wilmington, CA	2	461	16	1	270
00851HSSLVLMET	Hovensa L.L.C.	Christiansted, VI	2	461	--	--	--
77017LYNDL12000	Lyondell-Citgo Refining L.P.	Houston, TX	--	--	2,380	175	40,360
77506CRWNC111RE	Crown Central Petroleum Corp. Houston Refinery	Pasadena, TX	--	--	97	7	1,644
48217MRTHN1300S	Marathon Ashland Petroleum L.L.C.	Detroit, MI	--	--	81	6	1,374
79905CHVRN6501T	Chevron USA El Paso Refinery	El Paso, TX	--	--	55	4	932

Source: *TRIReleases2000*.¹Two additional refineries, Calcasieu, Lake Charles, LA and Frontier, El Dorado, Kansas each reported 1.1 lb/year PAC released to surface water. However, EPA did not include these releases in *TRIReleases2000*.²Mass transferred to POTW that is ultimately discharged to surface waters. Accounts for POTW removals.

Table 7-12. California Refineries Reporting PAH Discharges

NPDES Permit Number	Refinery Name	Location	Table 7-13 Refinery Number	PAHs, lb/yr
CA0000051	Conoco	Arroyo Grande, CA	6 ¹	0
CA0004961	Tesoro Refining & Marketing Co.	Martinez, CA		0.13
CA0005053	Tosco Refining Company	Rodeo, CA		0
CA0005134	Chevron Products Company	Richmond, CA	1 ²	1.5
CA0005789	Shell Oil Products US	Martinez, CA		0
CA0055387	Mobil Oil Corp.	Torrance, CA	7 ³	0

Source: PCSLoads2000.

¹Refinery also monitors for the individual PAC, benzo(j,k)fluorene (fluoranthene). See Table 7-13.

²Refinery also monitors for eight individual PACs (see Table 7-13), none of which were detected in 2000.

Table 7-13 lists the PACs that each of the seven refineries shown in the table must monitor as required by their NPDES permits. However, none of the refineries reported discharge concentrations above method detection limits in 2000.

Table 7-13. Individual PACs Reported in 2000 PCS

Pollutant	Refinery Number (see bottom of table)						
	1	2	3	4	5	6	7
Benzo(a)pyrene	✓	✓	✓	✓	✓		
Dibenzo(a,h)anthracene	✓	✓			✓		
Benzo(b)fluoranthene	✓	✓		✓	✓		
Benzo(a)anthracene	✓	✓	✓	✓			
Benzo(k)fluoranthene	✓	✓	✓	✓	✓		
Benzo(a)phenanthrene (chrysene)	✓	✓	✓	✓	✓		
Indeno(1,2,3-cd)pyrene	✓	✓			✓		
Benzo(j,k) fluorene (fluoranthene)	✓	✓	✓	✓		✓	✓
1. Chevron (Richmond, CA)		NPDES Permit CA0005134					
2. Valero Refining (Benecia, CA)		NPDES Permit CA0005550					
3. Bayway Refinery (Linden, NJ)		NPDES Permit NJ0001511					
4. Conoco Phillips (Borger, TX)		NPDES Permit TX0009148					
5. Murphy Oil (Superior, WI)		NPDES Permit WI0003085					
6. Conoco Phillips (Aroyo Grande, CA)		NPDES Permit CA0000051					
7. Mobil Oil (Torrance, CA)		NPDES Permit CA0055387					

7.6.4.3 Data Provided in Comments Regarding Preliminary Plan

As discussed in Section 7.2.1.4, API provided effluent data for activated sludge units at 10 refineries. These data, collected from 1993 to 1994, show that individual PACs were never measured above detection limits. Table 7-14 includes the PAC measurement data from API's comment (1).

Table 7-14. PAC Measurement Data from Activated Sludge Units at 10 Refineries

PAC Compound	Number of Samples	Minimum	Median	Maximum	Number of Samples > Detection Limit
Benzo(a)anthracene	26	<0.1	<10	<11	0
Benzo(a)phenanthrene (chrysene)	26	<0.2	<10	<11	0
Benzo(a)pyrene	26	<0.2	<10	<11	0
Benzo(b)fluoranthene	26	<0.2	<10	<11	0
Benzo(k)fluoranthene	26	<0.2	<10	<11	0
Benzo(j,k)fluorene (fluoranthene)	26	<0.6	<10	<11	0
Dibenz(a,h)acridine	1	<0.1	<0.1	<0.1	0
Dibenzo(a,h)anthracene	26	<0.3	<10	<11	0
Dibenzo(a,e)pyrene	1	<25	<25	<25	0
7,12-Dimethylbenz(a)anthracene	2	<10	<10	<10	0
Indeno(1,2,3-cd)pyrene	25	<0.2	<10	<11	0
3-Methylcholanthrene	24	<10	<10	<11	0

Source: American Petroleum Institute, *Comments Re. Notice of Preliminary Effluent Guidelines Program Plan*, March 18, 2004.

The County Sanitation Districts of Los Angeles County (the Districts) provided sampling results (1984-1993) from 13 refineries for EPA's *1996 Preliminary Data Summary*. EPA published the results of the sampling in Table 6-2 of the *1996 Preliminary Data Summary*. Benzo(a)phenanthrene (chrysene) was detected once, slightly above the method detection level, at a concentration of 10.5 ug/L (24).

The Districts' comments (3) also state that currently no PACs are found in the final effluent or biosolids from the Joint Water Pollution Control Plant (JWPCP). The JWPCP currently receives wastewater from 10 refineries. The Districts' NPDES permit requires monitoring for the following 13 individual PAHs (five included in the PAC category):

- Acenaphthylene;
- Anthracene;
- 1,2-benzanthracene;
- 3,4-benzofluoranthene;
- Benzo(k)fluoranthene (PAC chemical);
- 1,12-benzoperylene;
- Pyrene;
- Benzo(a)pyrene (PAC chemical);
- Benzo(a)phenanthrene (chrysene) (PAC chemical);
- Dibenzo(a,h)anthracene (PAC chemical);
- Flourene;
- Indeno (1,2,3-cd) pyrene (PAC chemical); and
- Phenanthrene

The Districts also reviewed the data reported to TRI in 2000 for the 10 refineries discharging to the JWPCP and found that none reported releases of PACs. The Districts noted that the refinery discharges have little particulate matter. Since PACs tend to accumulate in the solids, the low discharges of particulate matter may explain the absence of PACs in releases to the POTW. The Districts have not performed any screening analysis for trace quantities of PAHs.

7.6.5 Further Analysis of PACs

EPA performed further analysis of PAC discharges to determine if effluent limitations and guidelines would be appropriate for this pollutant. As discussed in Section 7.2.1.4, EPA received comments from NPRA and API concerning the TRI estimates of PACs discharges. The comments explained that 2000 was the first year industry was required to report releases of PACs to TRI. The comments further noted that even if refineries do not detect PACs in the effluent, they may estimate the mass released based on one-half the detection limit, and thus over-report PAC discharges to TRI. Table 7-15 summarizes the refinery-specific comments concerning PAC discharge estimates reported to the 2000 TRI. Table 7-15 also presents the basis for the facility estimate of PAC releases reported to TRI. EPA confirmed that PACs were measured above method detection limits in Lyondell Citgo's discharge to the Washburn Tunnel Facility (part of the Gulf Coast Waste Disposal Authority); however, PACs are not detected in the Washburn Tunnel Facility's discharge to surface water (10, 14). EPA could not confirm that PACs were measured in the discharges of any other refinery reporting PACs releases to TRI in 2000.

EPA estimated the concentration of PACs in refinery effluents using the discharges reported to TRI and process wastewater flow rate reported to PCS³, and compared these estimated concentrations to Method 1625 analytical detection limits for individual PACs. If a refinery reporting to TRI did not report a flow rate to PCS, or if the reported flow rate

³EPA calculated the wastewater flow rates from outfalls discharging BOD₅ and/or ammonia to estimate refinery process wastewater flows, because PCS does not consistently identify which discharges are process wastewater. Effluent limitations guidelines apply to BOD₅ and ammonia in refinery process wastewater discharges, but not cooling water and stormwater.

Table 7-15. NPRA and API Comments on PAC Discharge Estimates Reported to the 2000 TRI

TRI ID	Refinery	Refinery Location	TRI ¹ PAC Discharge (lb/yr)	Measured PACs?	Basis of Estimate for TRI Releases 2000 ²	NPRA and API Comments on PAC Discharge Estimate
77592TXSCTLOOP1	Valero Refining Co. Texas	Texas City, TX	64	No	M	Estimate based on ½ the detection limit. One sample contained PACs.
94572NCLSNOLDHI	Tosco San Francisco Refinery	Rodeo, CA	57	No	M	Estimate based on ½ the detection limit.
70037LLNCRHIGHW	Tosco Refining Co. Alliance Refinery	Belle Chasse, LA	40	No	O	Estimate based on ½ the detection limit.
70669CNCLKOLDSP	Conoco Lake Charles Refinery	Westlake, LA	22	No	O	No comments.
96707CHVRN91480	Chevron Prods. Co. Hawaii Refinery	Kapolei, HI	20	Unknown	M	No comments.
99611TSRLSMILE2	Tesoro Alaska Co. Kenai Refinery	Kenai, AK	19	No	O	No change to estimate.
39567CHVRNPOBOX	Chevron Prods. Co. Pascagoula Refinery	Pascagoula, MS	17	No	O	No comments.
62454MRTHNMARAT	Marathon Ashland Petroleum LLC	Robinson, IL	15	No	O	No comments.
62084SHLLLRTTE11	Tosco Wood River Refinery	Roxana, IL	10	No	O	Estimate based on ½ the detection limit.
74603CNCNP1000S	Conoco Inc. Ponca City Refinery	Ponca City, OK	9	No	O	Refinery estimated discharge using API data for PACs in petroleum products.
84116CHVRN2351N	Chevron USA Prods. Co	Salt Lake City, UT	8	No	O	No comments.
16344PNNZL2MAIN	Calumet Lubricants Co. Rouseville Plant	Rouseville, PA	5	No	O	Closed January 1, 2002. Not a refinery (SIC code 2999 Petroleum Products NEC).
80022CNCNDN5801B	Conoco Denver Refinery	Commerce City, CO	5	No	O	Estimate based on internally generated factors.
70047TRNSM14902	Orion Refining Corp.	New Sarpy, LA	4	No	C	Estimate based on ½ the detection limit.
90744TXCRF2101E	Equilon Enterprises LLC Los Angeles Refining	Wilmington, CA	3	No	O	No comments.
00851HSSLVLIMET	Hovensa L.L.C.	Christiansted, VI	2	No	O	Discharge from accidental spill; monitoring data indicate zero discharge of PACs.
77017LYNDL12000	Lyondell-Citgo Refining L.P.	Houston, TX	2,380	Yes	NA	Indirect discharger - PACs were not detected in the POTW effluent.
77506CRWNC111RE	Crown Central Petroleum Corp. Houston Refinery	Pasadena, TX	97	Unknown	NA	Indirect discharger - PACs were not detected in the POTW effluent.

Table 7-15 (Continued)

TRI ID	Refinery	Refinery Location	TRI ¹ PAC Discharge (lb/yr)	Measured PACs?	Basis of Estimate for TRI Releases 2000 ²	NPRA and API Comments on PAC Discharge Estimate
48217MRTHN1300S	Marathon Ashland Petroleum L.L.C.	Detroit, MI	6	Unknown	NA	No comments.
79905CHVRN6501T	Chevron USA El Paso Refinery	El Paso, TX	56	No	NA	Estimate based on ½ the detection limit.
70606CLCSRWESTE	Calcasieu	Lake Charles, LA	1.1	Unknown	M	Not in <i>TRIReleases2000</i> : 1.1 lb/yr discharge PACs reported to TRI.
67042TXCRF1401S	Frontier	El Dorado, KS	1.1	Unknown	O	Not in <i>TRIReleases2000</i> : 1.1 lb/yr discharge PACs based on discharges at similar refinery reported to TRI.

¹Mass transferred to POTW that is ultimately discharged to surface waters. Accounts for POTW removals.

²Refineries reported basis of estimate in 2000 TRI as: M - Monitoring data/measurements; C - Mass balance calculations; E - Published emission factors; and O - Other approaches (e.g., engineering calculations). NA means the refinery did not report the basis of its estimate.

seemed unreasonably high, EPA did not calculate PAC concentrations for that refinery. To compare concentrations to detection limits, EPA had to estimate concentrations for individual compounds, even though refineries report the total mass of PACs released to TRI. To do this, EPA assumed the distribution of individual PACs reported released was proportional to the concentration of individual PACs in petroleum products and the amount of the various products processed by the refining industry. EPA used this same distribution to calculate the PAC TWF for the petroleum refining industry (see Section 7.6.2). Table 7-16 lists the calculated concentrations of individual PACs in the refinery wastewater. The table also lists each compound's detection limit for Method 1625 as a comparison. As shown in the table, the individual PAC concentrations in the effluent are much lower than individual PAC detection limits, suggesting that individual PACs are not present in treated refinery wastewater above method detection limits.

For some pollutants, one refining process may be the primary source of the pollutant loadings to the treatment system. The in-process wastewater stream from this one process may contain high concentrations of the pollutant before dilution occurs with other refinery wastewater. In these cases, dedicated pretreatment might be effective in removing the pollutant. Based on the data for the detailed review, EPA did not identify an in-process waste stream with high concentrations of PACs or an in-process PAC source that could be controlled.

Because of the low water solubility and high octanol water partition coefficient of PACs, they are likely to partition from water to oily and solids phases. Subsequently, PACs are removed with oils and solids from the refinery wastewater through existing on-site treatment (oil in oil/water separators, solids in biological treatment, and sludge in clarifiers and polishing units).

7.6.6 PAC Control Technologies

Based on the information collected to date, EPA concludes that the PAC concentration in refinery wastewater is typically below treatable levels; however, refineries can use pollution prevention opportunities to reduce the possible contamination of refinery wastewaters by PACs. The main pollution prevention steps that refineries can take are to identify and correct any leaks quickly and to have controls in place to prevent petroleum spills from reaching any sewers or other waters.

If a refinery identifies any oily wastewater streams with high levels of PACs, it can treat the wastewater in an oil/water separator. PACs generally partition into the oil phase. The oil may then be reused at the refinery or managed as waste. Refineries can also use granular activated to remove water-phase PACs from pretreated wastewater.

Table 7-16. Estimated Concentration of PACs in Petroleum Refining Effluent

Refinery Information			Estimated Individual PAC Concentration in Effluent (ug/L)								
State	TRI Reported Pounds Discharged ^a	Flow ^b (Mgal/yr)	Fluoranthene	Benz(a)anthracene	Chrysene	Benzo(b)fluoranthene	Benzo(j)fluoranthene	Benzo(k)fluoranthene	Benzo(a)pyrene	Indeno(1,2,3-cd)pyrene	Dibenz(a,h)anthracene
Detection Limits ^c (ug/L)			10	10	10	10	10	10	10	20	20
AK	19	138	4.00	2.88	7.62	0.45	0.06	0.12	0.69	<0.00	0.07
CA	57	850	1.95	1.40	3.72	0.22	0.03	0.06	0.34	<0.00	0.03
CO	5	727	0.20	0.14	0.38	0.02	<0.00	0.01	0.03	<0.00	<0.00
HI	20	1,171	0.50	0.36	0.95	0.06	0.01	0.01	0.09	<0.00	0.01
IL	10	2,439	0.12	0.09	0.23	0.01	<0.00	<0.00	0.02	<0.00	<0.00
IL	15	1,615	0.27	0.19	0.52	0.03	<0.00	0.01	0.05	<0.00	<0.00
LA	22	1,343	0.48	0.34	0.91	0.05	0.01	0.01	0.08	<0.00	0.01
MS	17	2,238	0.22	0.16	0.42	0.02	<0.00	0.01	0.04	<0.00	<0.00
OK	9	991	0.27	0.19	0.50	0.03	<0.00	0.01	0.05	<0.00	<0.00
TX	64	766	2.44	1.75	4.64	0.27	0.04	0.07	0.42	<0.00	0.04
UT	8	290	0.80	0.58	1.53	0.09	0.01	0.02	0.14	<0.00	0.01

Source: ERG. *Memorandum: Estimated Concentrations for the Petroleum Refining Industry.*

¹Total pounds reported by each refinery is distributed to individual compounds using PAC compositions obtained in the *Memorandum: Toxic Weighting Factor for Petroleum Refining Polycyclic Aromatic Compounds*, 12/11/2003, DCN 00646.

²Flow is obtained from PCS and is only for outfalls with nonzero discharges of ammonia or BOD₅.

³Source: EPA Method 1625, Semivolatile Organic Compounds by Isotope Dilution GC/MS.

7.6.7 Detailed Study Findings on PACs

Below is a summary of the findings of EPA's detailed study of refinery PACs.

- PACs are a group of 21 individual compounds, some of which are present in petroleum products. U.S. industrial facilities were first required to report PAC releases to TRI for reporting year 2000. Using TRI data as reported (and accounting for POTW removals), EPA estimated that petroleum refineries released 487 pounds of PACs to surface water in 2000.
- EPA calculated the TWPE of PACs released from petroleum refineries using an industry-specific TWF, based on the concentration of individual PACs in petroleum products and the amount of products processed by the refining industry. Using TRI data, EPA estimated that refineries discharged 112,329 TWPE of PACs in 2000.
- For TRI reporting year 2000, 19 refineries reported PAC releases to wastewater. EPA determined that most of the reported releases were not based on measured concentrations in refinery effluents. Even where effluent concentrations were measured and individual PACs were not detected, refineries estimated releases using one-half the analytical detection limit and refinery effluent flow rate.
- EPA confirmed that PACs were measured above method detection limits in the discharge of Lyondell Citgo to the Washburn Tunnel Facility (part of the Gulf Coast Waste Disposal Authority); however, PACs are not detected in the Washburn Tunnel Facility's discharge to surface water. EPA could not confirm that PACs were measured in the discharges of any other refinery reporting PACs releases to TRI in 2000.
- Ten refineries have NPDES permit limits for PAHs (16 compounds measured by Method 610) or individual PACs. Eight individual PAH compounds are also included in the PAC compounds category reportable to TRI. In 2000, none of the refineries reporting to PCS measured individual PACs above detection limits. Two of six refineries required to monitor for PAHs (Chevron Products Company in Richmond, CA and Tesoro Refining & Marketing Company in Martinez, CA) reported PAH concentrations above detection limits. The Chevron Products Company (Richmond, CA) also monitors for eight individual PACs, none of which were detected in 2000.
- In comments submitted on the 2003 annual review, API provided effluent data collected at 10 refineries in 1993-1994. These data show individual PACs were never measured above analytical detection limits.

- EPA estimated concentrations of PACs using discharges as reported to TRI and process wastewater flow rate from PCS and compared these estimated concentrations to Method 1625 analytical detection limits for individual PACs. In all cases, estimated compound concentrations were much lower than Method 1625 detection limits.
- EPA did not identify an in-process wastestream with high concentrations of PACs, and so it similarly did not identify appropriate in-process treatment technology.

Based on these findings, EPA concludes that other than potential leaks and spills of crude oil and petroleum products, there is no obvious source of PAC releases to refinery wastewaters. EPA also concludes that there is little evidence that PACs are present in concentrations above the detection level in refinery wastewater discharges.

7.7 **Dioxins**

The term ‘dioxins’ refers to polychlorinated dibenzo-p-dioxins (CDDs) and polychlorinated dibenzofurans (CDFs). These groups of chemicals are termed ‘dioxin-like,’ because they have similar chemical structure, similar physical-chemical properties, and invoke a common battery of toxic responses. CDDs and CDFs must have chlorine substitution of hydrogen atoms at the 2, 3, 7, and 8 positions on the benzene rings (29). This section includes the following subsections:

- Section 7.7.1 - Identification and description of dioxins;
- Section 7.7.2 - Estimation of TWPE for petroleum refineries;
- Section 7.7.3 - Dioxin sources at petroleum refineries;
- Section 7.7.4 - Reported dioxin discharges;
- Section 7.7.5 - Compilation and discussion of measured effluent dioxin concentrations;
- Section 7.7.6 - Dioxin control technologies; and
- Section 7.7.7 - Detailed study findings for dioxins.

7.7.1 **Identification and Description of Dioxins**

Table 7-17 lists the 17 individual compounds (congeners) included in the TRI dioxin and dioxin-like category, and their CAS numbers. See Section 4.2.4.2 for more discussion of dioxins.

Table 7-17. Individual Dioxin Congeners

CAS Number	Chemical Name	Abbreviated Name
CDDs		
1746-01-6	2,3,7,8-tetrachlorodibenzo-p-dioxin	2,3,7,8-TCDD
40321-76-4	1,2,3,7,8-pentachlorodibenzo-p-dioxin	1,2,3,7,8-PeCDD
39227-28-6	1,2,3,4,7,8-hexachlorodibenzo-p-dioxin	1,2,3,4,7,8-HxCDD
57653-85-7	1,2,3,6,7,8-hexachlorodibenzo-p-dioxin	1,2,3,6,7,8-HxCDD
19408-74-3	1,2,3,7,8,9-hexachlorodibenzo-p-dioxin	1,2,3,7,8,9-HxCDD
35822-46-9	1,2,3,4,6,7,8-heptachlorodibenzo-p-dioxin	1,2,3,4,6,7,8-HpCDD
3268-87-9	1,2,3,4,6,7,8,9-octachlorodibenzo-p-dioxin	1,2,3,4,6,7,8,9-OCDD
CDFs		
51207-31-9	2,3,7,8-tetrachlorodibenzofuran	2,3,7,8-TCDF
57117-41-6	1,2,3,7,8-pentachlorodibenzofuran	1,2,3,7,8-PeCDF
57117-31-4	2,3,4,7,8-pentachlorodibenzofuran	2,3,4,7,8-PeCDF
70648-26-9	1,2,3,4,7,8-hexachlorodibenzofuran	1,2,3,4,7,8-HxCDF
57117-44-9	1,2,3,6,7,8-hexachlorodibenzofuran	1,2,3,6,7,8-HxCDF
72918-21-9	1,2,3,7,8,9-hexachlorodibenzofuran	1,2,3,7,8,9-HxCDF
60851-34-5	2,3,4,6,7,8-hexachlorodibenzofuran	2,3,4,6,7,8-HxCDF
67562-39-4	1,2,3,4,6,7,8-heptachlorodibenzofuran	1,2,3,4,6,7,8-HpCDF
55673-89-7	1,2,3,4,7,8,9-heptachlorodibenzofuran	1,2,3,4,7,8,9-HpCDF
39001-02-0	1,2,3,4,6,7,8,9-octachlorodibenzofuran	1,2,3,4,6,7,8,9-OCDF

Because of their extremely low water solubility and hydrophobicity, dioxins most often associate with particulate matter in wastewater matrices (24).

7.7.2 Estimation of TWPE

Facilities report to TRI the combined mass of dioxin-like compounds released to the environment. As discussed in 4.2.4.2, facilities also report the distribution of each individual chemical (congener) in the dioxin category. Facilities report only a single distribution to TRI, even though dioxins might be released to more than one medium, and may be distributed differently in different media. Lacking other information, EPA assumed the distribution reported applies to the wastewater discharges.

EPA has TWFs for each of the 17 dioxin congeners. Seventeen petroleum refineries reported water discharges of dioxins, but only five reported the distribution of the 17 congeners. For each refinery reporting congener distribution, EPA used the reported distribution to estimate the mass of each congener in the refinery's wastewater releases. EPA calculated

dioxin TWPEs by multiplying the estimated mass of each congener by its TWF⁴. If no congener distribution was reported, EPA used the refinery industry average distribution to calculate the mass of each congener.

7.7.3 Dioxin Sources at Petroleum Refineries

Dioxin and dioxin-like compounds are not manufactured, but are generated as by-products of certain chemical and combustion processes. As discussed in Section 7.3.3.3, EPA identified catalyst regeneration operations for the catalytic reforming process as the source of dioxins generated at petroleum refineries (24, page G-1). Smaller quantities of dioxins might be generated in isomerization units (37). See Section 7.3.3.3 for a detailed description of reforming catalyst wastewater generation.

7.7.4 Reported Dioxin Discharges

Seventeen refineries reported wastewater releases of dioxins to TRI in 2000, but PCS includes results of NPDES-permit-required monitoring for only three refineries (all three monitor for 2,3,7,8-TCDD, the most toxic form, or TCDD equivalents (TEQ)). EPA obtained additional information on refinery dioxin discharges from EPA's *1996 Preliminary Data Summary*, Washington State Department of Ecology sampling data, BP Amoco, Toledo Refinery, and Tosco Refining Company Avon Refinery's *Dioxin Source Investigation*. Each of these sources is described below.

7.7.4.1 TRI Discharges

As noted in Section 7.7.2, refineries report the dioxin discharges as a total category amount with the option to also report a congener distribution. Sixteen petroleum refineries reported releases of dioxins to surface water in 2000. One refinery reported dioxin transfers to a POTW. Note that current guidance for reporting to TRI suggests using one-half the detection limit to estimate releases based on "nondetects"; therefore, the total discharges might be overestimated. Table 7-18 presents the data reported to TRI and the calculated TWPE.

⁴EPA revised the TWFs for dioxins in 2004. The memorandum entitled *Revisions to TWFs for Dioxin and its Congeners and Recalculated TWPEs for OCPSF and Petroleum Refining* (available in the docket) presents the estimated TWPE for petroleum refineries using the revised TWFs.

Table 7-18. Petroleum Refineries Reporting Releases of Dioxins to 2000 TRI

TRI ID	Refinery Name	Refinery Location	Direct Discharge (grams/yr)	Direct Discharge (TWPE)	To POTW (grams/yr)	After POTW ¹ (grams/yr)	After POTW ¹ (TWPE)	Did Refinery Report Dioxin Congener Distribution?
98221SHLLWESTM	Tesoro Northwest Co.	Anacortes, WA	2	19,264	–	–	–	✓
77590MRTHNFOOTO	Marathon Ashland Petroleum LLC	Texas City, TX	5.2	52,202	–	–	–	–
70669CNCLKOLDSP	Conoco Lake Charles Refinery	Westlake, LA	0.5392	14,074	–	–	–	–
94802CHVRN841ST	Chevron Products Co. Richmond Refinery	Richmond, CA	0.339997	6,785	–	–	–	✓
90245CHVRN324WE	Chevron USA Prods. Co.	El Segundo, CA	0.329997	5,477	–	–	–	✓
43616SHLCM4001C	BP Oil Co. Toledo Refinery	Oregon, OH	0.285997	14,188	–	–	–	✓
07036XXN 1400P	Bayway Refining Co.	Linden, NJ	0.253997	10,322	–	–	–	✓
74603CNCNPN1000S	Conoco Inc. Ponca City Refinery	Ponca City, OK	0.180878	4,721	–	–	–	–
59101CNCBL401SO	Conoco Inc. Billings Refinery	Billings, MT	0.161558	4,217	–	–	–	–
08066MBLLCBILLI	Valero Refining Co. NJ	Paulsboro, NJ	0.089999	2,349	–	–	–	–
00851HSSLVLIMET	Hovensa LLC	Christiansted, VI	0.069341	1,810	–	–	–	–
80022CNCNCDN5801B	Conoco Denver Refinery	Denver, CO	0.059999	1,566	–	–	–	–
39567CHVRNPOBOX	Chevron Prods. Co. Pascagoula Refinery	Pascagoula, MS	0.035	914	–	–	–	–
62454MRTHNMARAT	Marathon Ashland Petroleum LLC	Robinson, IL	0.03	783	–	–	–	–
00654PHLPSPHILI	Chevron Phillips Chemical Puerto Rico	Guayama, PR	0.00218	57	–	–	–	–
70602CTGPTHIGHW	Citgo Petroleum Corp	Lake Charles, LA	0.0016	42	–	–	–	–
79905CHVRN6501T	Chevron USA El Paso Refinery	El Paso, TX	–	–	0.11	0.0186998	488	–

Source: TRIReleases2000.

¹Mass transferred to POTW that is ultimately discharged to surface waters. Accounts for POTW removals.

7.7.4.2 PCS Discharges

Three petroleum refineries, listed in Table 7-19, have NPDES permits in 2000 that required them to monitor their effluent for 2,3,7,8-TCDD or TCDD equivalents. One refinery (Tesoro Refining, Martinez, CA) detected dioxins in its effluent in 2000. The Tesoro refinery reports dioxin concentrations as TCDD equivalents. See Section 7.7.4.4 for further discussion of dioxin concentrations measured in petroleum refinery final effluents.

Table 7-19. Petroleum Refineries Reporting 2,3,7,8-TCDD to the 2000 PCS

NPDES ID	Refinery Name	Refinery Location	Direct Discharge (milligrams/yr)	Direct Discharge (TWPE/yr)
AL0055859	Shell Oil Mobile	Saraland, AL	0	0
CA0004961	Tesoro Refining	Martinez, CA	0.664 ¹	617.24
WI0003085	Murphy Oil USA Inc	Superior, WI	0	0

Source: PCSLoads2000.

¹Refinery reports TCDD equivalents.

7.7.4.3 In-Plant Monitoring

Washington State Department of Ecology Sampling

In NPDES permits it recently issued, Washington State Department of Ecology required four petroleum refineries to collect samples of catalytic reformer regeneration wastewaters, final effluent, and API separator sludge, and to analyze these samples for dioxins using EPA Method 1613b for wastewater and Method 8290 for sludge. Table 7-20 provides information on each of the refineries and samples.

EPA Sampling in Support of 1996 Preliminary Data Summary (PDS)

In the early 1990s, EPA conducted three sampling episodes at California petroleum refineries. Tables 6.8 through 6.9 of the *1996 Preliminary Data Summary* (24) present chlorinated dioxin and furan analytical data obtained from this sampling program. The Agency collected samples of regeneration wastewater from Chevron (Richmond, CA); Tosco (Martinez, CA); and Unocal (Rodeo, CA). EPA conducted the study, in part, so that it could develop dioxin analytical methods for analyzing refinery wastewaters. The Chevron samples were analyzed for dioxins by Method 8290 and the samples from the other two refineries were analyzed by Method 1613.

Table 7-20. Dioxin Sampling Data from Washington State Refineries (2000-2003)

Refinery	Location	Type of Regeneration	Regeneration Capacity (barrels/day)	Regeneration Episode/Sample Name	Discharge (gallons/min)	Discharge (gallons)	Time for Regeneration (hours)
Tesoro Northwest Co.	Anacortes, WA	Cyclic	24,300	Regeneration wastewater: Round 1	22	293,000	222
				Regeneration wastewater: Round 2	22	364,000	276
				Final effluent: Round 1	-	3,073,000	-
				Final effluent: Round 2	-	2,088,000	-
				API sludge: Round 1	-	116,000 dry lbs	-
				API sludge: Round 2	-	unavailable	-
U.S. Oil & Refining Co.	Tacoma, WA	Semi-regenerative	5,750	Regeneration wastewater: CRU1-1		2,217	45 (CRU1-1 plus CRU1-2)
				Regeneration wastewater: CRU1-2		2,574	
				Regeneration wastewater: CRU2-1		2,955	48 (CRU2-1 plus CRU2-2)
				Regeneration wastewater: CRU2-2		2,951	
				Final effluent: CRU1		304,416	
				Final effluent: CRU2		419,184	
				API separator sludge: CRU1		37,000 dry lbs	
				API separator sludge: CRU12		40,000 dry lbs	
ARCO Cherry Point Refinery (was BP)	Blaine, WA	Semi-regenerative	60,480	Reformer #1 (May 2000)	120	226,800	31.5
				Reformer #1 (April 2001)	128	215,000	28
				Reformer #2 (Sept 2000)	290	470,250	27
				Reformer #2 (March 2001)	303	618,100	34
				Final effluent (May 2000)	-	-	-
				Final effluent (Oct 2000)	-	-	-
				Final effluent (Mar 2001)	-	-	-
				Final effluent (April 2001)	-	-	-
				API separator sludge (May 2000)	-	-	-
				API separator sludge (Oct 2000)	-	-	-
				API separator sludge (April 4, 2001)	-	-	-
				API separator sludge (April 11, 2001)	-	-	-
				Shell Oil Products USA	Anacortes, WA	Semi-regenerative	32,200
Caustic Water Wash: CRU1 (Mar 2003)	-	26,670	-				
Caustic Water Wash: CRU2 (Jan 2004)	-	22,860	-				
Caustic Water Wash: CRU1 (Mar 2004)	-	26,670	-				
Final Effluent: CRU2 (Jan 2003)	-	-	-				
Final Effluent: CRU1 (Jan 2003)	-	-	-				
Final Effluent: CRU2 (Jan 2004)	-	-	-				
API Sludge (Jan 2003)	-	-	-				
API Sludge (Mar 2003)	-	-	-				

Source: Washington State Department of Ecology, Letter of Transmittal, December 11, 2003 (DCN 00711): Tesoro Northwest study, May 2001, Cherry Point Refinery study, July 2001, and U.S. Oil & Refining study, August 15, 2003; and Shell Oil Products U.S. Puget Sound Refinery, *Dioxin Study Report (NPDES Permit WA-000294-1)*, June 2004.

Table 7-21 summarizes in-plant sampling data obtained from Washington Department of Ecology and EPA's 1990-91 sampling program reported in the *1996 Preliminary Data Summary*. The table also includes the dioxin concentrations in API separator sludge and treated final effluent obtained from the Washington refineries. EPA converted all detected congeners to TCDD equivalents and assumed results reported as less than the analytical detection limit to equal zero.

Table 7-21. TCDD Equivalents in Petroleum Refinery Wastes

		TCDD Equivalents (assuming nondetects = 0)	
		Median	Range
Catalyst Reformer Regeneration Wastewater			
Concentration	pg/L	2,975	0 to 394,000
Loadings	mg/cycle	5.64	0 to 84
API Separator Sludge			
Concentration (mass based)	ng/kg sludge	13.61	3 to 356
Treated Final Effluent			
Concentration	pg/L	0	0 to 15.5

Sources: Washington State Department of Ecology. Letter of Transmittal. December 11, 2003 (DCN 00711); U.S. EPA, *1996 Preliminary Data Summary*; Shell Oil Products U.S. Puget Sound Refinery, *Dioxin Study Report* (NPDES Permit WA-000294-1), June 2004; and ERG, *Toxic Equivalents for Dioxins Reported in 2000 to TRI* (Calculation Sheet).

High concentrations of dioxins, including 2,3,7,8-TCDD and 2,3,7,8-TCDF, were detected in catalytic reformer regeneration wastewaters. EPA calculated the mass of TCDD equivalents discharged per regeneration cycle, using reported wastewater flows. The median loading was 5.64 milligrams per regeneration cycle.

In contrast to the catalytic reformer regeneration wastewater results, none of the Washington refineries detected either 2,3,7,8-TCDD or 2,3,7,8-TCDF in their treated final effluent. Two of the four Washington refineries detected no dioxins in their treated final effluent (see Table 7-23). The Tesoro Northwest sampling results included split samples taken in March 2000 and analyzed by two laboratories; five congeners were detected in the treated final effluent (by one or both laboratories). In the August 30, 2000 sampling episode for Tesoro Northwest, nine congeners were detected in the treated final effluent (by one or both laboratories). The congener, 1,2,3,4,6,7,8-HpCDF, was detected in both sampling episodes by both laboratories. Shell Oil Products Puget Sound Refinery detected one congener (OCDD) in its final effluent for the January 2003 sampling episode.

Catalytic reformer regeneration wastewaters are routed to the refinery wastewater treatment system through the API oil/water separator. Because of the low water solubility and extreme hydrophobicity of dioxins, at least some of the dioxins from catalytic reformer regeneration wastewaters partition to the oil and solids phases in the API separator and

accumulate in the sludges. As expected, all of the Washington state refineries detected dioxins in their API separator sludge.

7.7.4.4 Industry Comments About Dioxins

As discussed in Section 7.2.1.4, EPA received comments from NPRA and API concerning the TRI estimates of dioxin discharges. The comments explained that 2000 was the first year industry was required to report releases of dioxins to TRI. NPRA and API noted that refineries may over-report dioxin discharges to TRI by using one-half the detection limit to estimate releases of dioxins when not detected in the effluent. Table 7-22 summarizes the refinery-specific comments concerning dioxin discharge estimates reported to the 2000 TRI. NPRA and API provided comments on 12 of the 15 refineries⁵ that reported discharging dioxins to TRI. Of those 12 refineries, four based their reported discharges on measurements of effluent dioxin concentration. Tesoro Northwest (Anacortes, WA) detected dioxins in multiple effluent samples, as discussed in Section 7.7.4.3. BP Oil Company Toledo Refinery (Oregon, OH) collected and analyzed one set of samples and measured nine dioxin congeners above detection limits. For the TRI reported releases in 2001 and 2002, the refinery set nondetects equal to zero; however, for 2002, the refinery modified its estimation method to set nondetects equal to one-half the detection limit. Bayway Refining (Linden, NJ) and Chevron (El Segundo, CA) did not detect dioxins in their effluent, but estimated the mass released based on one-half the detection limit.

7.7.5 **Compilation and Discussion of Measured Effluent Dioxin Concentrations**

Table 7-23 summarizes dioxin concentrations measured in final effluent from eight U.S. petroleum refineries. Data presented include concentrations reported in PCS, the Washington State permit-required dioxin study results (18, 36), a special report prepared by the Tosco Refinery in Martinez, CA (now owned by Tesoro) in April 1997 (19), data summarized in EPA's *1996 Preliminary Data Summary* (24), and data submitted to EPA by BP Oil Company Toledo Refinery (2). Data in these various sources have different nomenclature. For example, some sources provide results as TEQ; others only provide discharge information for 2,3,7,8-TCDD. See Section 4.2.4.2 for additional discussion on dioxin nomenclature. In order to compare these results, Table 7-23 also provides the associated TWPE. EPA did not include refinery TRI data in Table 7-23, because refineries do not report concentrations to TRI. However, as discussed above only two of the four facilities that based their TRI-reported dioxin discharges on actual measurements detected dioxin in their effluent. EPA has concentration data from these two facilities from other sources and has included those data in Table 7-23.

⁵A 16th refinery, Marathon Ashland Petroleum (Detroit, MI) originally reported discharging 8.06 grams of dioxins in 2000. The refinery submitted a TRI correction form, and EPA changed the reported discharge to 0 grams for this analysis.

Table 7-22. NPRA and API Comments on Dioxin Discharge Estimates Reported to the 2000 TRI

TRI ID Number	Refinery	Refinery Location	TRI Releases 2000 ¹ Dioxin Discharge (gram/yr)	Basis of Estimate for TRI Releases 2000 ²	NPRA and API Comment on Dioxin Releases Reported to TRI
98221SHLLLWESTM	Tesoro Northwest Co.	Anacortes, WA	5.199947	M	2001 discharge = 1.6 grams, 2002 discharge = 1.7 grams
77590MRTHNFOOTO	Marathon Ashland Petroleum LLC	Texas City, TX	2	O	No comment.
70669CNCLKOLDSP	Conoco Lake Charles Refinery	Westlake, LA	0.5392	E	No comment.
94802CHVRN841ST	Chevron Prods. Co. Richmond Refinery	Richmond, CA	0.339997	O	Based on detection limit. Two samples analyzed (no values above detection limit).
90245CHVRN324WE	Chevron USA Prods. Co.	El Segundo, CA	0.329997	M	Based on detection limit. Only OCDD was detected.
43616SHLCM4001C	BP Oil Co. Toledo Refinery	Oregon, OH	0.285997	M	One set of samples collected and analyzed: 9 congeners above the detection limit.
07036XXN 1400P	Bayway Refining Co.	Linden, NJ	0.253997	M	Based on ½ the detection limit. Treated effluent samples are all ND.
74603CNCNP1000S	Conoco Inc. Ponca City Refinery	Ponca City, OK	0.180878	O	Estimated discharge using nonrefinery-specific data for dioxin in petroleum products.
59101CNCBL401SO	Conoco Inc. Billings Refinery	Billings, MT	0.161558	O	Estimated discharge using nonrefinery-specific data for dioxin in petroleum products.
08066MBLLCBILLI	Valero Refining Co. New Jersey	Paulsboro, NJ	0.089999	O	Reported wastewater release was 0.0002 grams.
00851HSSLVLIMET	Hovensa LLC	Christiansted, VI	0.069341	C	Based on EPA discharge factors .
80022CNCNDN5801B	Conoco Denver Refinery	Denver, CO	0.059999	O	Internally generated factors per corporate policy.
39567CHVRNPOBOX	Chevron Prods. Co. Pascagoula Refinery	Pascagoula, MS	0.035	O	No comment.
62454MRTHNMARAT	Marathon Ashland Petroleum LLC	Robinson, IL	0.03	O	No comment.
00654PHLPSPHILI	Chevron Phillips Chemical Puerto Rico	Guayama, PR	0.00218	E	No comment.

Table 7-22 (Continued)

TRI ID Number	Refinery	Refinery Location	TRI Releases 2000 ¹ Dioxin Discharge (gram/yr)	Basis of Estimate for TRI Releases 2000 ²	NPRA and API Comment on Dioxin Releases Reported to TRI
70602CTGPTHIGHW	Citgo Petroleum Corp	Lake Charles, LA	0.0016	E	Based on EPA discharge factors.
79905CHVRN6501T	Chevron USA El Paso Refinery	El Paso, TX	0.109999	O	Based on ½ the detection limit.
Refineries Not in EPA's Analysis: No Discharge of Dioxins					
48217MRTHN1300S	Marathon Ashland Petroleum LLC	Detroit, MI	8.061218	NA	Incorrect number reported: should be zero discharge. Refinery submitted TRI correction form.

¹Mass transferred to POTW that is ultimately discharged to surface waters. Accounts for POTW removals.

²Refineries reported basis of estimate in 2000 TRI as: M - Monitoring data/measurements; C - Mass balance calculations; E - Published emission factors; and O - Other approaches (e.g., engineering calculations).

Table 7-23. Dioxin Concentrations Measured in U.S. Petroleum Refinery Final Effluent

Facility	Source	Results	2,3,7,8-TCDD (pg/L)	TEQ (pg/L)	Measured TWPE (lb-eq)
Tesoro Northwest Company Anacortes, WA	(1)	<i>March 8, 2000</i> - Split sample analyzed by two labs. Results shown average two results. Five congeners detected by at least one lab, including 1,2,3,4,6,7,8-HpCDF by both labs. <i>August 30, 2000</i> - split sample analyzed by two labs. Results shown average two results. Nine congeners detected by at least one lab, including 1,2,3,4,6,7,8-HpCDF by both labs.	<3 <4	3.1 to 21.3 ¹ 15.5 to 37.9 ¹	29.9 to 196 ²
ARCO Cherry Point Refinery Blaine, WA	(1)	<i>May 3, 2000</i> - No congeners detected. <i>October 1, 2000</i> - No congeners detected. <i>April 6, 2001</i> - No congeners detected. <i>April 13, 2001</i> - No congeners detected.	<10 <10 <10 <10	0 0 0 0	0
U.S. Oil & Refining Co. Tacoma, WA	(1)	<i>July 16-17, 2002</i> - No congeners detected. <i>June 23 -24, 2002</i> - No congeners detected.	ND ND	0 0	0
Shell Oil Products US Puget Sound Refinery Anacortes, WA	(2)	<i>January 2003</i> - Only OCDD detected. <i>March 2003</i> - No congeners detected. <i>January 2004</i> - No congeners detected.	ND ND ND	0.012 0 0	0.81 to 741 ²
Shell Oil Mobile Saraland, AL	(3)	<i>1998 to 2000</i> - permit requires yearly monitoring for 2,3,7,8-TCDD. Never detected.	ND	0	0
Murphy Oil USA Inc. Superior, WI	(3)	<i>February 29, 2000</i> - permit requires monitoring for 2,3,7,8-TCDD	<2.7	0	0
Tesoro Refining (Previously Tosco) Avon Refinery Martinez, CA	(3)	<i>March 31, 2000</i> <i>June 30, 2000</i> <i>October 31, 2000</i> permit requires quarterly reporting TCDD-equivalents. Discharge is 98% nonprocess, 2% process.	NR NR NR	0.00028 0.30 0.09	12.8
	(4)	<i>January - December, 1996</i> - Outfall to bay - Results reported as TCDD TEQ. Individual congeners not reported. Outfall includes process and nonprocess sources of dioxins. Result shown is 12 month average. <i>June 1996</i> - GAC outlet. Treated process wastewater. <i>August 1996</i> - GAC outlet. Treated process wastewater	NR NR NR	0.47 0.012 0.00	NC

Table 7-23 (Continued)

Facility	Source	Results	2,3,7,8-TCDD (pg/L)	TEQ (pg/L)	Measured TWPE (lb-eq)
Tesoro Refining (Previously Tosco) Avon Refinery Martinez, CA	(5)	ca 1989 -Outfall to bay. 13 ppq TCDF detected; not found when sample reanalyzed. Re-analyzed sample. Only OCDD detected	ND ND	1.3 0.12	NC
BP Oil Company Toledo Refining Oregon, OH	(6)	2000 - 9 congeners detected	0 to 0.84 ³	0 to 4.29 ³	0 to 24,800 ³
TOTAL MEASURED DIOXIN DISCHARGE:					43.5 to 25,800

Sources:

- (1) Washington State Department of Ecology. Letter of Transmittal. December 11, 2003 (DCN 00711).
- (2) Shell Oil Products U.S. Puget Sound Refinery. *Dioxin Study Report (NPDES Permit WA-000294-1)*. June 2004.
- (3) U.S. EPA. *PCSLoads2000*.
- (4) Tosco Refining Company Avon Refinery. *Dioxin Source Investigation Pursuant to Cease and Desist Order No. 95-151, Final Report*.
- (5) U.S. EPA, *1996 Preliminary Data Summary*, Table 6.9.
- (6) BP Oil Company. *Water Samples for PCDD/PDCF for the BP Oil Company Toledo Refinery*. Performed by Batelle. November 9, 2000.

NC - Not calculated, reporting data for 2000 used to calculate TWPE for refinery.

ND - Not detected, detection limit not reported.

NR - Not reported.

¹Low value assumes ND = 0; high value assumes ND = detection limit.

²Total year 2000 discharges. Low value assumes ND = 0; high value assumes ND = detection limit.

³All concentrations reported by BP were less than low end of calibration curve. Low value assumes all results were ND, and ND = 0. High value assumes detected results present at reported concentration and ND = detection limit.

As shown in Table 7-23, only one refinery (BP Toledo Refinery) detected the most toxic form of dioxin, 2,3,7,8-TCDD, in its final effluent. Four of the eight refineries did not detect any dioxins in their final effluent. The four refineries that detected dioxins in their effluent were Tesoro (previously Tosco) (Martinez, CA); Tesoro Northwest (Anacortes, WA); Shell Puget Sound Refinery (Anacortes, WA); and BP Toledo Refinery (Oregon, OH).

Table 7-24 summarizes the petroleum refinery treated effluent data for individual dioxin and furan congeners measured at three of the four facilities that detected dioxins in their final effluent (Tesoro Northwest, Shell Puget Sound, and BP Toledo). All results are presented in picograms per liter (pg/L). EPA did not present the data for the fourth refinery because the refinery provided only summary results.

In 1997, the Tesoro (Martinez, CA) refinery completed an extensive study to find the source of dioxin in its wastewaters (see DCN 710). The study determined that stormwater is the largest source of dioxin in the final effluent (50 percent) with the coke pond and clean canal forebay as the second largest (45 percent) (19). The refinery reported that the wastewater treatment plant (i.e., treated process wastewater) contributed 2 percent of the dioxins in the final effluent (19). The facility collected and analyzed two samples of fully treated process wastewater for this study. The analytical results were 0.000 pg/L TCDD-equivalents and 0.012 pg/L TCDD-equivalents (19). These concentrations equate to 12.8 lb-equivalents. In comparison, the calculated TCDD-equivalents of the concentrations detected in the final effluent in 2000 were 0.00028, 0.30, and 0.09 pg/L (34).

The Tesoro Northwest Refinery (Anacortes, WA) sampled its effluent on two occasions, during batch discharges of treated wastewater generated during the regeneration of catalytic reformer spent catalyst. Each sample was analyzed by two independent analytical laboratories. Tesoro Northwest detected between 6 and 11 dioxin congeners in its final effluent (36). However, two compounds were present in the corresponding laboratory blank. Several other compounds were detected below the lower calibration limit. OCDF and 1,2,3,4,6,7,8-HpCDF were detected about the method minimum level by both laboratories and in both samples. The most toxic dioxin forms (2,3,7,8-TCDD and 2,3,7,8-TCDF) were not detected in any samples (36). The refinery has not done an additional study to identify the sources of dioxin in its final effluent (17). At this point, because the dioxin concentrations in the upstream source (catalytic reformer regeneration wastewaters) are also high, EPA assumes the spent caustic/wash water from catalytic reformer regeneration is the source of the dioxins in the final effluent. These effluent measurements equate to 29.9 to 196 TWPE (low value assumes nondetects equal zero and high value assumes nondetects equal the detection limit).

The Shell Puget Sound Refinery (Anacortes, WA) sampled its effluent on three occasions, corresponding to the regeneration of catalytic reformer spent catalyst. Shell Puget Sound detected OCDD at a concentration of 120 pg/L in its final effluent during the January 2003 sampling episode. For the March 2003 and January 2004 sampling episodes, the refinery

Table 7-24. Treated Effluent Dioxin/Furan Sample Results, pg/L

Dioxin Congener	Method 1613b ML pg/L	Tesoro Northwest (Anacortes, WA)				Shell Puget Sound Refinery (Anacortes, WA)			BP Toledo (Oregon, OH)
		3/2000		8/2000		1/2003	3/2003	1/2004	9/2000
		Lab A	Lab B	Lab A	Lab B				
CDDs									
2,3,7,8-TCDD	10	ND	ND	ND	ND	ND	ND	ND	0.84j
1,2,3,7,8-PeCDD	50	ND	ND	ND	ND	ND	ND	ND	1.12j
1,2,3,4,7,8-HxCDD	50	ND	ND	ND	ND	ND	ND	ND	ND
1,2,3,6,7,8-HxCDD	50	ND	ND	ND	ND	ND	ND	ND	ND
1,2,3,7,8,9-HxCDD	50	ND	ND	ND	ND	ND	ND	ND	ND
1,2,3,4,6,7,8-HpCDD	50	39b	35j	153	35j	ND	ND	ND	1.62j
OCDD	100	100b	110	1160b	130	120	ND	ND	15.12j
CDFs									
2,3,7,8-TCDF	10	ND	ND	ND	ND	ND	ND	ND	ND
1,2,3,7,8-PeCDF	50	ND	ND	13.2a	ND	ND	ND	ND	2.09j
2,3,4,7,8-PeCDF	50	ND	ND	20.2a	ND	ND	ND	ND	1.52j
1,2,3,4,7,8-HxCDF	50	35	43	83.6	33j	ND	ND	ND	1.63j
1,2,3,6,7,8-HxCDF	50	17a	ND	57.6	ND	ND	ND	ND	ND
1,2,3,7,8,9-HxCDF	50	13a	ND	46.5	ND	ND	ND	ND	ND
2,3,4,6,7,8-HxCDF	50	9.7a	ND	38.7	ND	ND	ND	ND	ND
1,2,3,4,6,7,8-HpCDF	50	100	130	412	110	ND	ND	ND	0.97j
1,2,3,4,7,8,9-HpCDF	50	34	40	145	38j	ND	ND	ND	ND

Table 7-24 (Continued)

Dioxin Congener	Method 1613b ML pg/L	Tesoro Northwest (Anacortes, WA)				Shell Puget Sound Refinery (Anacortes, WA)			BP Toledo (Oregon, OH)
		3/2000		8/2000		1/2003	3/2003	1/2004	9/2000
		Lab A	Lab B	Lab A	Lab B				
OCDF	100	200	270	935	200	ND	ND	ND	1.28j

Sources: Washington State Department of Ecology. Letter of Transmittal. December 11, 2003 (DCN 00711); Shell Oil Products U.S. Puget Sound Refinery. *Dioxin Study Report (NPDES Permit WA-000294-1)*. June 2004; and BP Oil Company. *Water Samples for PCDD/PDCF for the BP Oil Company Toledo Refinery*. Performed by Batelle. November 9, 2000.

ML - Minimum Level.

a/j - Compound present, detected below the lower calibration limit.

b - Detected in method blank.

detection no dioxins in its final effluent (18). These measurements equate to 0.81 to 741 TWPE (low value assumes nondetects equal zero and high value assumes nondetects equal the detection limit).

The BP Toledo Refinery (Oregon, OH) sampled its effluent once in September 2000. It has a continuous discharge of wastewater from its catalytic reforming regeneration. BP Toledo detected nine congeners, including the most toxic form, 2,3,7,8-TCDD, in its final effluent. However, no dioxins were detected above the lower calibration limit or the method minimum level. Although these compounds were below the lower calibration limit, they were probably present in the sample. EPA estimates treated effluent TWPE range from 0 to 25,800 (low value assumes nondetects equal zero and high value assumes nondetects equal the detection limit). (2)

EPA notes that many of the detected dioxin concentrations at these refineries are close to the analytical minimum level and that some sample-specific detection levels and detected concentrations are below the Method 1613b minimum level. Method 1613b is the analytical method EPA specifies for compliance when it establishes 2,3,7,8-TCDD limits in the effluent guidelines program. The minimum level is the smallest quantity that the method can reliably measure. Also, EPA has historically regulated dioxins as 2,3,7,8-TCDD and establishes the limit as below the minimum level. All of information from the eight facilities that measured for dioxins (including BP Toledo) indicates 2,3,7,8-TCDD is below the minimum level of 10 pg/L.

Data from these eight refineries indicate that while dioxins may be generated during catalyst regeneration operations, dioxin concentrations measured at the effluent are close to the minimum level or below the minimum level. This indicates that the dioxins are being removed from the wastestream prior to discharge. Because dioxins have a low water solubility and extreme hydrophobicity, EPA expects that the dioxins from catalytic reformer regeneration wastewaters partition to the oily and solids phases in the API separator and accumulate in the sludges.

Finally, EPA notes that the total TWPE based on measured discharged by refineries is 43.5 to 25,800 TWPE (low value assumes nondetects equal zero and high value assumes nondetects equal the detection limit) compared to the 139,258 TWPE calculated using the 2000 TRI data, as reported.

7.7.6 Dioxin Control Technologies

As described in the *1996 Preliminary Data Summary*, after reviewing data collected in its 1990-91 refinery sampling program, EPA noted that greater than 90 percent of the TEQ were associated with solids-phase samples. This indicated that dioxins might be treated at the source by filtration technology prior to commingling the regeneration wastewater with wastewaters from other refinery operations (24, page G-22).

To control dioxins in wastewater, Shell Canada (Sarnia, Ontario Canada) implemented carbon filtration pretreatment of spent caustic from the catalytic reformer. The pretreatment system consists of two carbon filters (165 pounds each) connected in series with a flow rate of five gallons per minute. After pretreatment, the refinery treats the wastewater in its end-of-pipe biological treatment system. The *1996 Preliminary Data Summary* did not discuss the effectiveness of this treatment. (24)

As described in *Dioxin Source Investigation Pursuant to CDO No. 95-151, Final Report* (19), the Tesoro Avon Refinery (owned by Tosco at the time of the report) operates both a continuous catalytic reformer and a semi-regenerative catalytic reformer. Off-gases from the continuous catalyst regeneration pass through a caustic scrubbing solution. A slipstream of washwater is constantly purged to the oily sewer at a rate of four gallons per minute. In 1993, the refinery installed a granular activated carbon (GAC) treatment system that successfully removed 95 to 99 percent of the dioxins found in the washwater from this wastestream. The refinery analyzed two samples of GAC effluent and reported the results as 0.012 pg/L TEQ for one sample and 0.00 pg/L TEQ for the other sample.

Tesoro's semi-regenerative catalytic reformer is shut down approximately once per year for regeneration. Washwater from this process contains dioxins. The refinery determined that allowing particulate in the catalyst regeneration wastewater to settle in tanks for a minimum of one week allows the dioxin concentrations in the liquid portion to drop to nearly zero. The settled liquid is pumped through a 1-micron filter sock prior to discharge to the oily sewer. The refinery disposes of the filter socks and collected particulate matter as dioxin-containing hazardous waste (19).

7.7.7 Detailed Study Findings for Dioxins

Below is a summary of the findings of EPA's detailed study of refinery dioxins.

- The term "dioxins," or polychlorinated dibenzo-p-dioxins (CDDs) and polychlorinated dibenzofurans (CDFs), refers to the 17 individual compounds (congeners) with chlorine substitution of hydrogen atoms at the 2, 3, 7, and 8 positions on the benzene rings. U.S. industrial facilities were first required to report dioxin releases to TRI in 2000. Facilities report the total mass of the 17 compounds released to the environment and the congener distribution of these releases. Using 2000 TRI data as reported (and accounting for POTW removals), **EPA estimated that petroleum refineries released 9.60 grams of dioxins to surface water in 2000.**
- EPA calculated the TWPE of dioxins released from petroleum refineries using facility-reported congener distributions. If a refinery did not report a congener distribution, EPA used the refining industry-specific average distribution to calculate the mass of each congener released. Using TWPEs for each congener and 2000 TRI data (accounting for POTW removals),

EPA estimated that refineries discharged 139,258 TWPE of dioxins in 2000.

- Using only final effluent data where dioxin discharges were measured analytically, EPA estimated that refineries discharged between 43.5 and 25,800 TWPE of dioxins in 2000 (over 80 percent less than the TWPE estimated using the TRI data as reported).
- In 1988, dioxins were identified in catalyst regeneration wastewater from Ontario petroleum refineries. In the early 1990s, EPA confirmed that reformer catalyst regeneration wastewater was the major source of dioxins in refinery process wastewater. In 2000, 122 refineries performed catalytic reformer regeneration.
- For this detailed study, EPA reviewed in-plant dioxin monitoring data from four sources:
 - Washington Department of Ecology permit-required sampling: results of sampling and analysis provided by three Washington refineries from 2001-2003.
 - Washington Department of Ecology permit-required sampling: results of sampling and analysis provided by Shell Oil Products U.S. Puget Sound Refinery from 2003 - 2004.
 - EPA-conducted sampling in support of its *1996 Preliminary Data Summary*: results of sampling at three California refineries in the early 1990s.
 - BP Oil Company Toledo Refinery sampling data from 2000.
- From the four sources above, **high concentrations of dioxins, including 2,3,7,8-TCDD and 2,3,7,8-TCDF, were detected in catalytic reformer regeneration wastewaters at all eight refineries:**
 - 2,975 pg/L - Median TCDD-equivalent concentration, and
 - 5.64 mg/cycle - Median loading per regeneration cycle.
- From the four sources above, four of the eight refineries detected dioxins in their final effluent.
- One of three refineries with NPDES permit limits for TCDD or TCDD-equivalents detected dioxins in their final effluent in 2000:

- Tesoro Refining (Martinez, CA) reported 0.00028, 0.09, and 0.3 pg/L in its final effluent.
- This refinery identified stormwater and coke pond water as contributing 95 percent of the mass discharged. Treated process wastewater contributed two percent of the mass. Sampling of treated process wastewater yielded 0.000 pg/L TCDD-equivalents and 0.012 pg/L TCDD-equivalents. This equates to 12.8 TWPE.
- For TRI reporting year 2000, 17 refineries reported wastewater dioxin releases.
 - For 15 of the 17 dioxin-reporting refineries, reported releases were either not based on measured concentrations, or when dioxin congeners were not detected, releases were estimated using one-half the analytical detection limit and refinery effluent flow.
 - For 2 of the 17 dioxin-reporting refineries, the reported releases appear to have been based on measured concentrations in refinery effluents.
 - BP Oil Company Toledo Refinery (Oregon, OH) - EPA received the 2000 analytical data report from the refinery. All concentrations reported by BP were less than the low end of calibration curve. Although the concentrations of these compounds were below the method minimum level, they were probably present in the sample. EPA estimates treated effluent TCDD-equivalents concentrations range from 0 to 4.29 pg/L, or 0 to 24,800 TWPE.
 - Tesoro Northwest (Anacortes, WA) - EPA received further data for this refinery as part of the Washington Department of Ecology permit requirements (see below).
- Four Washington refineries provided permit-required final effluent sampling results.
 - Dioxins were not detected in the treated final effluent of two of these refineries.
 - EPA estimates treated effluent TCDD-equivalent concentrations at Tesoro Northwest (Anacortes, WA) are between 3.1 and 37.9 pg/L. The process wastewater (spent caustic/wash water) from catalytic reformer regeneration contains high concentrations of dioxins. Most dioxins settle with the solids and become part of the API

separator sludge; however, the refinery effluent still contains dioxins above detection limits. The most toxic form of dioxins were not detected in any effluent samples. Dioxin in treated effluent equate to 29.9 to 196 TWPE.

- EPA estimates treated effluent TCDD-equivalents concentrations at Shell Puget Sound Refinery (Anacortes, WA) are between 0 and 0.012 pg/L, or 0.81 to 741 TWPE. The process wastewater (caustic water wash) from catalytic reformer regeneration contains high concentrations of dioxins; however, almost all of the dioxins settle with the solids and become part of the API separator sludge. The refinery detected only one congener in the final effluent in one of the three sampling episodes.
- Four Washington refineries provided permit-required API separator sludge sampling results. Dioxins were detected in the sludge from all four of these refineries, including the two refineries with no dioxins in their final effluent.
- Tesoro Refinery in Martinez, CA practices in-plant treatment of segregated catalytic reforming catalyst regeneration wastewater.
 - GAC removes 95 to 99 percent of the dioxins in continuous catalytic reformer off-gas scrubber blowdown.
 - Settling and solids filtration removes dioxins from semi-regenerative catalytic reformer regeneration wash water.

Based on the information collected during the detailed review, EPA concludes that dioxins might be produced in high concentrations at petroleum refineries during reformer catalyst regeneration processes. While some dioxin congeners might be present in the treated effluent at some refineries, the most toxic congeners, 2,3,7,8-TCDD and 2,3,7,8-TCDF, have only been detected in the final effluent at one petroleum refinery at a concentration below the method minimum level. TWPE estimates from eight facilities that sampled their treated effluent for dioxins ranges from 43.5 to 25,800 TWPE. EPA notes that these TWPE estimates are based on dioxin concentrations close to the analytical minimum level. In addition, the highest estimated TWPE (24,800 TWPE at the BP Toledo Refinery) was calculated for an effluent sampled only once, with all detected congener concentrations below the Method 1613b minimum level.

Contamination of API separator sludge with dioxins suggests that at least some of the dioxins from catalytic reformer regeneration wastewater partition to the oily and solid phases in the API separator and accumulate in the sludge. API separator sludges are managed as hazardous wastes.

In-process control technology effectively removes dioxins from segregated catalytic reforming catalyst regeneration wastewater. This control technology consists of solids removal and/or GAC adsorption. Permit writers should consider the use of these technologies as they develop permit limits that reflect their “Best Professional Judgement” (BPJ) of what constitutes BAT for an individual refinery.

7.8 Metals

Petroleum refinery wastewater contains a number of metal pollutants. In 2000, petroleum refineries reported wastewater releases of over 20 metals⁶ to TRI and refineries in PCS monitored their effluent for discharges of over 30 metals.

7.8.1 Identification and Description of the Metals Discharged in Petroleum Refinery Wastewater

Table 7-25 provides information on the metals commonly found in discharges from petroleum refineries, and identifies if the metal is reportable to TRI or is a CWA priority pollutant. Petroleum refinery effluent limitations guidelines found in 40 CFR Part 419 include limitations for hexavalent and trivalent chromium.

Table 7-25. Metals in Petroleum Refining Wastewater

Pollutant	Reportable to TRI?	Priority Pollutant?	Limits in 40 CFR Part 419?
Aluminum			
Arsenic	✓	✓	
Chromium	✓	✓	✓
Copper	✓	✓	
Lead	✓	✓	
Mercury	✓	✓	
Nickel	✓	✓	
Selenium	✓	✓	
Vanadium	✓	-	
Zinc	✓	✓	

¹Aluminum is only reportable to TRI in its fume or dust form.

7.8.2 Sources of Metals at the Petroleum Refinery

Crude petroleum is the major source of metals at petroleum refineries. Metals found in crude petroleum, and their concentrations, depend on the origin of the crude oil. For example, selenium is contained in some crude oils, particularly from parts of California (3).

⁶For this review, two nonmetallic elements, arsenic and selenium, are included with metals.

Other sources of metals in refinery wastewater include pipe corrosion (e.g., chromium), catalyst additives, other refinery raw materials, cooling water biocide (e.g., chromium), and supply water (37).

Desalter wastewater will most likely have the largest concentration of metals, especially mercury. Another process wastewater source of metals is wash water from other refining steps (37).

7.8.3 Reported Metal Discharges

EPA estimated metal loadings for the petroleum refining industry using data reported to TRI and PCS in 2000. In addition, EPA used metals discharge data for 23 refineries from the *1996 Preliminary Data Summary* (24) and for 10 refineries from API (1).

7.8.3.1 Mass Discharges: TRI and PCS

Table 7-26 presents the pollutant loadings for metals estimated using discharges reported to TRI for 2000. Metals account for 22 percent of the total industry TWPE discharge estimated with TRI data when PAC and dioxin discharges are included. However, as discussed in Sections 7.6 and 7.7, EPA has little evidence that PACs and dioxin releases reported to TRI reflect measurable concentrations in refinery effluents. Metals make up almost 70 percent of the TRI TWPE when PACs and dioxins are not included in the total, and 17 percent of the PCS TWPE.

Table 7-26. Metals Discharges as Percentage of Total TWPE

Pollutant	Total TWPE Discharged	Percentage of Total TWPE Discharged
TRI Loads		
Metals	84,368	22% ¹
Total	373,177	
PCS Loads		
Metals	33,547	17%
Total	192,862	

Source: *TRIRelases2000* and *PCSLoads2000*.

¹Metals compose 70 percent of the TRI TWPE if PACs and dioxins are excluded.

As shown in Table 7-27, based on data reported to both the TRI and PCS, a few metals contribute most of the TWPE. Table 7-28 presents information from *TRIRelases2000*, showing the five metals with the highest estimate of TWPE released to surface waters in 2000. Vanadium comprises most of the TWPE in releases reported to TRI in 2000; 14 refineries reported releasing more than 55,000 TWPE of vanadium, or 65 percent of the metal TWPE.

Table 7-27. Top Five Metals as Percentage of Total Metal TWPE

Pollutant	PCS		TRI	
	Total Pounds Discharged	Total TWPE Discharged	Total Pounds Discharged	Total TWPE Discharged
Total Metals	202,860	33,547	182,265	83,266
Top 5 Metals ¹	130,684	26,042	98,215	75,961
Top 5 as percentage of total metals	64%	78%	54%	91%

Source: *TRIRelases2000* and *PCSLoads2000*.

¹Top five TRI metals include vanadium, mercury, selenium, chromium and lead. Top five PCS metals include selenium, aluminum, arsenic, mercury and lead.

Table 7-28. Five Metals with Highest Estimated TWPE (TRI)

Pollutant	TRI		
	Number of Refineries	Total Pounds Discharged	Total TWPE Discharged
Vanadium	14	88,778	55,240
Mercury	20	100	11,768
Selenium	2	2,655	2,975
Chromium	13	5,049	2,322
Lead	14	1,632	3,656

Source: *TRIRelases2000*.

The federal effluent limitations and guidelines for petroleum refineries include metal limits only for chromium (total and hexavalent); however, state and local permits may require refineries to monitor for other metal compounds. Table 7-29 presents information from *PCSLoads2000*, showing the five metals with the highest estimate of TWPE discharged to surface waters in 2000. Selenium comprises most of the TWPE in discharges calculated using PCS data; 18 refineries reported selenium discharges, accounting for more than 9,000 TWPE of selenium, or 27 percent of the metal TWPE.

Table 7-29. Five Metals with Highest Estimated TWPE (PCS)

Pollutant	PCS		
	Number of Refineries	Total Pounds Discharged	Total TWPE Discharged
Selenium	18	8,068	9,041
Aluminum	5	120,235	7,754
Arsenic	10	1,663	5,769
Mercury	7	16	1,908
Lead	10	701	1,571

Source: PCSLoads2000.

7.8.3.2 Additional Metals Data (Concentrations)

EPA reviewed additional petroleum refinery metals discharge data and compared these concentrations to baseline values and promulgated effluent guidelines. Each of the data sources is discussed below and Table 7-30 presents these data.

Preliminary Data Summary

As part of the study described in EPA's 1996 *Preliminary Data Summary* (24), EPA visited and collected effluent data from six refineries. Table 7-30 presents the range of effluent metals concentrations collected from these refineries. No data on concentrations of arsenic, mercury, or vanadium were available for these refineries.

EPA also obtained one-year average concentration data collected during Ontario's *Seven Refineries Study*, conducted in 1989 (24). Table 7-30 presents these average concentrations. No data on concentrations of mercury or vanadium were available for these refineries.

API Supplied Data

EPA received comments from API on the December 31, 2003 *Notice of the Preliminary Effluent Guidelines Program Plan for 2004/2005*. API provided a set of petroleum refining effluent data that were previously collected by its members in conjunction with EPA's Office of Solid Waste (1). Data were collected from refineries following activated sludge treatment. Most of the metals with high TWPE discharges as reported to TRI were not detected above analytical detection limits. The exceptions were nickel, selenium, and vanadium. Table 7-30 presents the median of the analytical results.

Calculated PCS Concentrations

As described in Section 7.2.2, EPA used data reported to PCS to estimate annual pollutant mass discharges. As further described in Section 7.5.2, EPA used PCS data to estimate annual process wastewater flow rates. EPA assumed that flows from effluent outfalls with limitations for BOD₅ and/or ammonia (as nitrogen) were process-related. For each refinery discharging metals as reported to PCS (in pounds), EPA estimated the metal concentration by dividing the mass discharged by the flow rate (and correcting the units). Table 7-30 presents the median of estimated metal concentrations.

Baseline Values

Table 7-30 also presents baseline values for metal pollutants to compare to the metals concentrations measured at petroleum refineries. EPA develops method-specific “baseline values” for analyzing measurement data collected for effluent guidelines development. In most cases, the baseline value is the “nominal quantitation limit” stipulated for the specific method used to measure a particular pollutant. In general, the term “nominal quantitation limit” describes the smallest quantity of an analyte that can be measured reliably. The baseline values shown in Table 7-30 were taken from Chapter 15 of the *Development Document for Centralized Waste Treaters (CWT) Point Source Category* (26).

Comparison of Concentrations

As shown in Table 7-30, the concentrations of arsenic, copper, lead, mercury, and nickel did not exceed the baseline value or method detection level in any of the data sources. As a result, EPA concludes that TWPEs calculated for these pollutants reflect concentrations below the method detection level multiplied by the refinery effluent flow rate. Chromium, selenium, vanadium, and zinc, however, were detected above the baseline value/method detection level in at least one data source. Each of these metals is discussed in more detail below.

Chromium concentrations exceeded the baseline value for one or more of the six refineries visited for the *1996 Preliminary Data Summary*. However, the highest concentration detected in samples taken for the *1996 Preliminary Data Summary* was 0.02 mg/L, slightly greater than the baseline value (0.01 mg/L) but less than the long-term average of the BPT/BAT technology (0.25 mg/L). Concentrations from the other data sources were all less than the method detection level. These data collectively demonstrate that chromium is rarely discharged above the method detection level or the BAT treatment performance concentration.

Table 7-30. Pollutant Discharge Concentrations for Metals at Petroleum Refineries

Pollutant	PDS Site Visit Data (6 refineries) Range, mg/L	Canada Study Data (7 refineries) Average, mg/L	1993/1994 Wastewater Treatment Effluent Data (10 refineries) Median, mg/L	2000 PCS Concentration Median, mg/L	Baseline Values (EPA Method Number 1620), mg/L	Comparison to Concentration Basis of Existing Regulation or Other Recently Promulgated Regulations, mg/L
<i>Source</i>	<i>1</i>	<i>2</i>	<i>3</i>	<i>4</i>	<i>5</i>	–
Arsenic	NA	0.009	< 0.1 (all ND)	0.0084	0.01	–
Chromium	0.015-0.02	0.0068	< 0.01	0.0067	0.01	0.25 ¹
Copper	0.01-0.13	0.0048	< 0.01 (all ND)	0.0066	0.025	–
Lead	0.001-0.012	0.0041	< 0.05 (all ND)	0.0031	0.050	–
Mercury	NA	NA	< 0.0002 (all ND)	0.00002	0.0002	–
Nickel	0.033-0.039	0.0034	0.04	0.023	0.040	–
Selenium	0.006-0.06	0.005	0.012	0.015	0.005	NA
Vanadium	NA	NA	0.26	0.015	0.05	NA
Zinc	0.04-0.147	0.29	< 0.02	0.04	0.020	1.48 (40 CFR Part 433) 0.42 (40 CFR Part 437) 0.26 (40 CFR Part 464 - Ferrous Subcategory) 0.18 (40 CFR Part 464 - Nonferrous Subcategory) ²

Sources:

- 1996 Preliminary Data Summary, Table 4-4.
- 1996 Preliminary Data Summary, Table 4-5, taken from *BAT for Ontario Petroleum Refining Sector*, August 1991.
- API Comment, Table 4, 1993-94 data collected in conjunction with EPA/OSW.
- Calculated using BOD₅-associated flow, and *PCSLoads2000* estimated annual mass discharge.
- Development Document for Centralized Waste Treaters (CWT) Point Source Category*, Attachment 15-1.

NA - Not available.

ND - Not detected.

¹BPT/BAT-equivalent concentration for existing regulation (40 CFR Part 419) as listed in U.S. EPA's *Development Document for Effluent Limitations Guidelines and New Source Performance Standards for the Petroleum Refining Point Source Category*, April 1974.

²40 CFR Part 433; 40 CFR Part 437.31: Organics Treatment and Recovery Subcategory; and U.S. EPA *Development Document for Final Effluent Limitations Guidelines and Standards for the Metal Molding and Casting (Foundry) Point Source Category* (40 CFR Part 464).

Selenium concentrations also exceeded the baseline value for one or more of the six refineries visited for the *1996 Preliminary Data Summary*. In addition, the median concentrations provided in the API comments and calculated from PCS 2000 exceeded the baseline value. Selenium is present in crude petroleum, especially from parts of California. In the 1990's, California permitting authorities conducted a selenium treatability study. As a result of the study, many California refineries shifted their crude supplies so that they received low selenium crude. In addition, for five refineries in the Los Angeles Basin, the LA County Sanitation Districts began implementing source control requirements for selenium. The control requirements are driven by local requirements for the disposal of the Districts' biosolids. The LA County Sanitation Districts commented that the General Pretreatment Regulations (40 CFR Part 403) and their local Wastewater Ordinance provides adequate control of selenium discharges by refineries (3).

EPA notes that it has historically not established national categorical limitations or standards for selenium in any existing ELGs. EPA did promulgate selenium limitations and standards in 40 CFR Part 437 based on primary chemical precipitation, liquid/solid separation, secondary precipitation, clarification, and sand filtration, but re-promulgated the regulation to delete these limitations. EPA found that selenium removal was achieved only on the last stage of the treatment technology basis, sand filtration, and that these removals were not consistent or predictable. See 68 FR 71014-71026.

The median concentration of vanadium provided in the API comments exceeded the baseline value; however, the more recent data from the 2000 PCS show concentrations below the baseline value. Vanadium is one of the metals that facilities are required to report to TRI. It is not limited in the existing effluent guideline. PCS contains little data on vanadium indicating that refinery discharge permits do not include vanadium requirements and that it has not been identified as a water quality issue.

For zinc, the median concentration calculated from PCS, the average concentration from the Canadian study, and the maximum of the range provided in the *1996 Preliminary Data Summary* exceeded the baseline value. EPA compared the zinc concentrations from petroleum refineries to BAT limitations (or basis) for three promulgated regulations:

- 1) Metal Finishing (40 CFR Part 433) - EPA recently evaluated the Metal Finishing Category when developing the Metal Products and Machinery regulations (40 CFR Part 438). EPA decided not to revise the Metal Finishing limitations for zinc (1.48 milligrams per liter, monthly average). The concentrations of zinc in refinery effluents are well below the Metal Finishing standard.
- 2) Centralized Waste Treatment - Organics Treatment and Recovery Subpart C (40 CFR Part 437.31) - EPA based the BPT monthly average limitation for zinc (0.420 milligrams per liter) on biological treatment. The concentrations of zinc in refinery effluents are below the standard

established for the Organics Treatment and Recovery Subcategory of the Centralized Waste Treatment regulations.

- 3) Metal Molding and Casting (40 CFR Part 464) - The treatment technology that serves as the basis for BAT limitations for Metal Molding and Casting is lime precipitation and sedimentation, followed by filtration. This effective metal control technology can achieve 30-day effluent concentrations of zinc equal to 0.26 milligrams per liter (ferrous subcategory) and 0.18 milligrams per liter (nonferrous subcategory). The median zinc concentrations for U.S. refineries are below even the concentrations achieved using lime precipitation and sedimentation, followed by filtration technology.

7.8.4 Metals Control Technologies

The metal concentrations in refinery final effluents are typically below treatable levels; however, permit writers may identify refinery-specific problems. Permit writers should use BPJ to evaluate available pollution prevention and treatment technologies when establishing NPDES permit limitations.

Metals are found in crude petroleum and petroleum products. The main pollution prevention steps that refineries can take are to quickly identify and correct any leaks and to maintain controls to prevent petroleum spills from reaching any sewers or other waters. In addition, refineries can monitor the amount of metals (especially mercury) present in incoming crude oil and reject shipments that exceed the refinery's acceptable levels.

Selenium and vanadium are two metal pollutants that have been identified in some refinery discharges. Vanadium can be removed from wastewater through sulfide precipitation. Typically the reaction is carried out with a pH of 7.0 to 9.0 (38). Existing control of selenium generally consists of source control requirements. However, selenium has been demonstrated to be removed from wastewater through sulfide precipitation at a pH of 6.5 (8).

7.8.5 Detailed Study Findings for Metals

Below is a summary of findings of EPA's detailed study of refinery metals.

- Metals that may be present in petroleum refining wastewater include aluminum, arsenic, chromium, copper, lead, mercury, nickel, selenium, vanadium, and zinc. Crude petroleum is the primary source of metals in refinery wastewater. The concentration of a metal in the crude depends on the source of the crude.
- Using TRI data as reported (and accounting for POTW removals), EPA estimated that refineries discharged 182,265 pounds (83,266 TWPE) of

metals in 2000. Vanadium discharges from 14 refineries compose 65 percent of the TWPE (> 55,000 TWPE).

- Using PCS data as reported, EPA estimated that refineries discharged 202,860 pounds (33,547 TWPE) of metals in 2000. Selenium discharges from 18 refineries compose 27 percent of the TWPE (9,000 TWPE).
- EPA identified concentration data from the *1996 Preliminary Data Summary* (from site visits and from the Canadian study *BAT for Ontario Petroleum Refining Sector*) and API comments. In addition, EPA calculated metals concentrations using PCS mass discharges and flow rates. Median concentrations of arsenic, copper, lead, mercury, and nickel did not exceed the baseline value or method detection level. This indicates that the refineries discharge these pollutants below detectable or treatable concentrations.
- The median concentrations of chromium, selenium, vanadium, and zinc exceed baseline values in at least one data source. These four metals are discussed below:
 - The effluent guidelines at 40 CFR Part 419 include limitations for chromium. The concentrations of chromium in any refinery wastewater evaluated are well below the concentration upon which current limitations were based. In addition, chromium was detected in only one data source at a concentration slightly above the baseline value.
 - Local limits are currently used to regulate selenium discharges from refineries.
 - EPA has not historically regulated selenium and vanadium discharges in existing ELGs due to difficulties in obtaining optimal removals using traditional wastewater treatment technologies.
 - In evaluated data, the zinc concentrations in U.S. refinery effluents are below previously promulgated limitations (Metal Finishing, 40 CFR Part 433 and Centralized Waste Treatment, 40 CFR Part 437) and BAT basis concentrations (Metal Molding and Casting, 40 CFR Part 464).

Based on data as reported to PCS and TRI, metals contribute 17 to 22 percent of the TWPE reported released by petroleum refineries in 2000. Based on the information for the detailed review, EPA concludes that the concentration of metal pollutants in refinery wastewaters is at or near treatable levels, leaving little to no opportunity to reduce metals discharges through conventional end-of-pipe treatment. Further, EPA did not identify an in-

process waste stream with high concentrations of metals and, similarly, could not identify an appropriate in-process treatment technology.

7.9 Conventional and Nonconventional Pollutants

Conventional pollutants found in petroleum refinery wastewater include BOD₅, total suspended solids (TSS), oil and grease, and pH. Nonconventional pollutants found in petroleum refining wastewater include ammonia as nitrogen (N), chemical oxygen demand (COD), cyanide, phenols, and sulfide. The current petroleum refining regulations (40 CFR Part 419) include limitations for all the conventional pollutants listed above, as well as ammonia as N, COD, phenols, and sulfide. 40 CFR Part 419 does not limit cyanide discharges from petroleum refineries.

7.9.1 Reported Conventional and Nonconventional Pollutant Discharges

The estimated conventional and nonconventional pollutant loadings for the petroleum refining industry are based on PCS data. In 2000, 104 refineries reported wastewater releases of conventional pollutants to PCS, and 102 refineries reported wastewater releases of nonconventional pollutants to PCS. In addition, EPA has discharge data for conventional and nonconventional pollutants for 138 refineries from the *1996 Preliminary Data Summary*.

7.9.1.1 Mass Discharges: PCS

Table 7-31 presents the pollutant loadings for conventional and nonconventional pollutants (excluding metals), and, for comparison, the metal loadings, estimated using discharges reported to PCS in 2000. Nonconventional pollutants (excluding metals) account for 83 percent of the total TWPE discharged by the industry using PCS data.

Table 7-31. Conventional and Nonconventional Pollutant Discharges in PCS

Pollutant	Total Pounds Discharged (millions)	Total TWPE Discharged	Percentage of Total TWPE Discharged
PCS Loads			
Conventional pollutants	45	¹	¹
Nonconventional pollutants (excluding metals)	287	159,315	83%
Metals	0.202	33,547	17%
Total	332	192,862	

Source: *PCSLoads2000*.

¹EPA does not have TWPEs for conventional pollutants, therefore, it cannot calculate TWPEs for these pollutants.

Tables 7-32 and 7-33 present the pollutant loadings for certain conventional and nonconventional pollutants estimated using discharges reported in 2000. EPA does not assign TWF to conventional pollutants. The nonconventional pollutant, sulfide, accounts for 63 percent of the total TWPE using PCS data; 70 refineries reported discharging more than 100,000 TWPE of sulfide.

Table 7-32. Conventional Pollutants with Highest Estimated Pounds Discharged (PCS)

Pollutant	PCS Top 5 Conventional Pollutants		
	Number of Refineries	Total Million Pounds Discharged	Total TWPE Discharged
Total suspended solids	97	27	-
Oil and grease, freon extr-grav method	69	7.5	-
BOD, 5-day	93	6.7	-
BOD, carbonaceous 5-day	6	0.76	-
Oil and grease	21	0.63	-

Source: PCSLoads2000.

Table 7-33. Nonconventional Pollutants with Highest Estimated TWPE (PCS)

Pollutant	PCS Top 5 Nonconventional Pollutants (except metals)		
	Number of Refineries	Total Million Pounds Discharged	Total TWPE Discharged
Sulfide, total ¹	70	0.036	100,734
Chlorine, total residual	13	0.052	25,357
Fluoride, total (as F)	11	0.46	16,198
Phenolics, total recoverable	68	0.26	7,336
Nitrogen, ammonia, total ²	87	2.0	3,581

Source: PCSLoads2000.

¹Sulfide, Total includes Sulfide, Total (as S).

²Nitrogen, Ammonia Total includes "Nitrogen Ammonia Total (AS N)" and "Nitrogen Ammonia Total (AS NH₄)."

7.9.1.2 Conventional and Nonconventional Pollutant Concentrations

EPA reviewed concentration data for petroleum refinery conventional and nonconventional pollutants and compared these concentrations to baseline values and promulgated effluent guidelines. The data sources for this data are discussed in the following section and Table 7-34 presents these data.

Table 7-34. Pollutant Discharge Concentrations for Conventional and Nonconventional Pollutants at Petroleum Refineries

Pollutant	Preliminary Data Summary Site Visit Data (6 refineries) Range, mg/L	Canada Study Data (7 refineries) Average, mg/L	1993/1994 Wastewater Treatment Effluent Data (10 refineries) Median, mg/L	2000 PCS Concentration Median, mg/L	EPA Method Number	Baseline Values, mg/L	Comparison to Concentration Basis of Existing Regulation or Other Recently Promulgated Regulations, mg/L
<i>Source</i>	<i>1</i>	<i>2</i>	<i>3</i>	<i>4</i>	<i>5</i>	<i>6</i>	
TSS	8.75-12	22	10	12.71	160.2	4.0	10 ¹
Oil and grease	2.7-4.2	2.17	NA	3.54	1664	5.0	5 ¹
Ammonia (as N)	0.94-1.43	1.7	NA	1.28	350.2	0.05	4 ²
COD	51-59.5	49.2	55.2	71.50	410.1	5.0	86 - 856 ³
Phenols, total	0.005-0.012	0.0110	NA	0.018	420.2	0.05	0.1 ¹
Sulfide, total	0.018-0.14	0.08	0.08	0.026	D4658	1.0	0.1 ¹
<i>Pollutants without Limitations at 40 CFR Part 419</i>							
Cyanide, total	NA	0.007	0.01	0.014	335.2	0.02	NR
Fluoride, total	NA	NA	NA	3.8	340.1	0.1	NR
Chlorine, total residual	NA	NA	NA	0.082	4500	0.1	NR

NA - Not available.

NR - Not regulated.

Sources:

1. U.S. EPA, *1996 Preliminary Data Summary*, Table 4-4.2. U.S. EPA, *1996 Preliminary Data Summary*, Table 4-5, taken from *BAT for Ontario Petroleum Refining Sector*, August 1991.

3. API Comment, Table 4, 1993-94 data collected in conjunction with EPA/OSW.

4. Calculated using BOD₅-associated flow, and *PCSLoads2000* estimated annual mass discharge.5 & 6. U.S. EPA, Development Document for Centralized Waste Treaters (CWT) Point Source Category, Table 15-1. And for Total Residual Chlorine: U.S. EPA, *Alternative Disinfectants and Oxidants Guidance Manual* (EPA 815-R-99-014). Office of Water. April 1999.¹BPT/BAT-equivalent concentration for existing regulation (40 CFR Part 419) as listed in U.S. EPA, *Development Document for Effluent Limitations Guidelines and New Source Performance Standards for the Petroleum Refining Point Source Category*, April 1974.²Monthly average ammonia limitation recently promulgated in Meats Subcategory (40 CFR Part 432).³Monthly average COD limitation promulgated in 1998 for the Pharmaceutical Manufacturing Category (40 CFR Part 439).

Preliminary Data Summary

As part of the study described in EPA's 1996 *Preliminary Data Summary* (24), EPA visited and collected effluent data from six refineries. Table 7-34 presents the range of effluent concentrations collected from these refineries for selected conventional and nonconventional pollutants. The data did not include cyanide concentrations.

EPA also obtained one-year average concentration data collected during Ontario's *Seven Refineries Study*, conducted in 1989. Table 7-34 presents these average concentrations (24).

API Comments

EPA received comments from API on the December 31, 2003 Notice of the Preliminary Effluent Guidelines Program Plan for 2004/2005. API provided a set of petroleum refining effluent data that were previously collected by its members in conjunction with EPA's Office of Solid Waste (1). Data were collected from refineries that use activated sludge treatment. Table 7-34 presents the median of the analytical results. The data did not include concentrations for oil and grease, ammonia, or phenol.

Calculated PCS Concentrations

As described in Section 7.2.2, EPA used data reported to PCS to estimate annual pollutant mass discharges. As further described in Section 7.5.2, EPA used PCS data to estimate annual process wastewater flow rates. EPA assumed that flows from effluent outfalls with limitations for BOD₅ and/or ammonia (as nitrogen) were process-related. For each refinery discharging conventional and nonconventional pollutants as reported to PCS (in pounds), EPA estimated the pollutant concentration by dividing the mass discharged by the flow rate (and correcting the units). Table 7-34 presents the range of estimated pollutant concentrations.

Baseline Values

Table 7-34 also presents baseline values for the conventional and nonconventional pollutants to compare to the pollutant concentrations measured at petroleum refineries. Section 7.8.3.2 describes baseline values in further detail.

Comparison of Concentrations

As shown in Table 7-34, with the exception of total suspended solids (TSS), the median concentrations of conventional and nonconventional pollutants are below the concentrations used as the basis for the limitations in 40 CFR Part 419. Median concentrations of four pollutants (TSS, ammonia (as N), COD, and total fluoride) were above the baseline values. The existing petroleum BPT/BAT limitations are based on wastewater equalization and stormwater diversion, multistage oil and solids removal, biological treatment, and effluent

polishing. EPA did not identify any additional treatment technologies to further reduce concentrations conventional and nonconventional pollutants in refinery wastewater.

Total Suspended Solids. Two of the six refineries visited as part of the *1996 Preliminary Data Summary* had TSS concentrations in the final effluent above BPT/BAT levels. Ninety-one petroleum refineries reported TSS to the 2000 PCS and 54 (59 percent) had TSS concentrations in the final effluent above BPT/BAT levels.

Ammonia (as N). This pollutant contributes 3,581 TWPE to surface water discharges from petroleum refineries. The current concentrations of ammonia (as N) are below the monthly average ammonia limitation (4 mg/L) recently promulgated for the Meats and Poultry Products Category (40 CFR Part 432).

Total Phenols. This pollutant contributes 7,336 TWPE to surface water discharges from petroleum refineries. Petroleum refineries are currently achieving final effluent concentrations less than baseline values and less than existing limits at 40 CFR Part 419.

Total Sulfides. This pollutant contributes 100,734 TWPE to surface water discharges from petroleum refineries. Petroleum refineries are currently achieving final effluent concentrations less than baseline values and less than existing limits at 40 CFR Part 419. Only one of the six refineries visited for the *1996 Preliminary Data Summary* exceeded the BPT/BAT basis concentration for total sulfide.

Total Fluoride. This pollutant contributes 16,198 TWPE to surface water discharges from petroleum refineries. Petroleum refineries are currently discharging concentrations of total fluoride above the baseline value. EPA currently does not regulate this pollutant for the petroleum refining industry.

Total Residual Chlorine. This pollutant contributes 25,357 TWPE to surface water discharges from petroleum refineries. Petroleum refineries are currently achieving final effluent concentrations less than the baseline value. EPA currently does not regulate this pollutant for the petroleum refining industry.

7.9.2 Detailed Study Findings for Conventional and Other Nonconventional Pollutants

Below is a summary of the findings of EPA's detailed study of refinery conventional and nonconventional pollutants.

- Regulations at 40 CFR Part 419 establish limitations for all conventional pollutants, except fecal coliform. EPA also established limitations for the nonconventional pollutants ammonia as nitrogen, COD, total phenols, and total sulfide.

- Using PCS data, EPA estimated that refineries discharged 45 million pounds of conventional pollutants and 287 million pounds (159,315 TWPE) of nonconventional pollutants in 2000. Sulfide discharges from 70 refineries compose 63 percent of the TWPE (> 100,000 TWPE).
- EPA identified concentration data for TSS, oil and grease, ammonia as N, COD, total cyanide, total phenols, and total sulfide from the *1996 Preliminary Data Summary* (from EPA site visits and from the Canadian study *BAT for Ontario Petroleum Refining Sector* (13)) and from data supplied in API comments. In addition, EPA calculated concentrations using PCS mass discharges and flow rates. With the exception of total suspended solids, the median pollutant concentrations were below 40 CFR Part 419 limitations or pollutant baseline values. Although certain pollutants (e.g., sulfide) contribute the large majority of TWPE discharged by petroleum refineries, the data demonstrate that refineries are currently discharging nonconventional pollutants at concentrations at (or near) treatable levels.

Therefore, based on the information for the detailed review, EPA concludes that refineries are treating nonconventional pollutants to concentrations at or near treatable levels.

7.10 Pollution Control

Additional pollution reduction may include both pollution prevention and end-of-pipe treatment, although as highlighted in the EPA Office of Compliance sector notebook, *Profile of the Petroleum Refining Industry*: “Pollution prevention techniques are often more cost-effective than pollution reduction through end-of-pipe treatment” (32). Wastewater pollution prevention strategies are presented below. Additional opportunities in the area of general operating and maintenance practices and procedures, and design revisions and modifications to various refining processes are described in EPA’s *Profile of the Petroleum Refining Industry* (32), Washington State Department of Ecology’s *Water Pollution Prevention Opportunities in Petroleum Refineries* (37), and DOE Office of Energy Efficiency and Renewable Energy’s *Water Use in Industries of the Future: Petroleum Industry* (22).

- Process or equipment modifications:
 - Reduce cooling tower blowdown by minimizing TDS in the cooling water. This can be achieved by removing calcium carbonate in the makeup water (or on a side stream of the cooling tower recycle system) by cold lime softening, reverse osmosis, or electrodialysis treatment. (32)
 - Increase sensible heat transfer and therefore minimize evaporative losses using improved cooling tower designs (22).

- Use high-pressure water to remove entrained solids from heat exchanger bundles. Separate the solids at the source or use antifoulants on the bundles to reduce scaling. (32)
- Limit surfactant use in cleaning operations; surfactants can increase the generation of emulsions and sludges (32).
- Destroy dioxins in flue gases in a furnace firebox, or capturing in a filter, rather than transferring them to scrubber water (37).
- Waste segregation:
 - Segregate relatively clean runoff from process sewers, which results in more efficient process wastewater treatment (32).
 - Control solids entering sewers to reduce generation of oily sludges (32).
- Material substitution:
 - Use mercury-free caustic in FCC air emission scrubbers (32).
 - Replace chromate-based anticorrosives with less toxic alternatives, such as phosphates, in cooling towers and heat exchangers (32).
- Re-use:
 - Reuse steam-stripped sour water or other treated wastewater as desalter make-up (32). The steam-stripped sour water contains a high concentration of phenolic compounds that are returned to the crude when used as desalter water makeup (22).
 - Blowdown from the steam systems including oily condensate may be used as desalter water makeup (22).
 - Reuse boiler blowdown, treated wastewater or stormwater runoff as makeup water to the cooling tower (22).
 - Use treated wastewater from off-site locations as makeup water.

7.11 Petroleum Refining References

1. American Petroleum Institute. *Comments Re. Notice of Preliminary Effluent Guidelines Program Plan*. March 18, 2004.

2. BP Oil Company. Water Samples for PCDD/PDCF for the BP Oil Company Toledo Refinery, Performed by Batelle. November 9, 2000.
3. The County Sanitation Districts of Los Angeles County. *Comments for the Preliminary Effluent Guidelines Program Plan for 2004/2005*. James F. Stahl. Whittier, CA. March 5, 2004.
4. Eastern Research Group, Inc. *Memorandum: Estimated PAC Concentrations for the Petroleum Refining Industry*. July 12, 2004.
5. Eastern Research Group, Inc. *Memorandum: Meeting Between EPA and Representatives of American Petroleum Institute and National Petrochemical & Refiners Association*. DCN: 00809. February 16, 2004.
6. Eastern Research Group, Inc. *Memorandum: Meeting Between EPA and Representatives of Lyondell-Citgo Refining, LP*. March 12, 2004.
7. Eastern Research Group, Inc. *Toxic Equivalents for Dioxins Reported in 2000 to TRI (Calculation Sheet)*. April 13, 2004.
8. Eckenfelder, W. Wesley, Jr. *Principles of Water Quality Management*. CBI Publishing Company, 1980. Page 491.
9. Gulf Coast Waste Disposal Authority (GCA). *2003 Peak Performance Award Application*.
10. GCA. *Comments on the Notice of the Preliminary Effluent Guidelines Program Plan for 2004/2005 (68 Fed. Reg. 75515, December 31, 2003), Docket Number OW-2003-0074*.
11. National Petrochemical & Refiners Association. *Comments by the National Petrochemical & Refiners Association (NPRO) on "Notice of Preliminary Effluent Guidelines Plan," Published on December 31, 2003 (68 FR 75515)*. Norbert Dee. Washington, D.C. March 15, 2004.
12. *Oil & Gas Journal*. "2001 Worldwide Refining Survey." Volume 99.52. December 24, 2001.
13. Ontario Ministry of the Environment. *Best Available Technology Options for the Ontario Petroleum Refining Sector*. Municipal/Industrial Strategy for Abatement (MISA) Program, ISBN 0-7729-9778-0. DCN 00398. August 1991.

14. Personal Communication, Chris Matthews, Lyondell-Citgo Refining, Houston, Texas. February 26, 2004.
15. Personal Communication, Christopher Abshire, Lyondell-Citgo Refining, Houston, Texas. March 2004.
16. Personal Communication, Gail Froiman, EPA Office of Environmental Information. November 13, 2003.
17. Personal Communication, Nancy Kmet, Washington (State) Department of Ecology. June 30, 2004.
18. Shell Oil Products U.S. Puget Sound Refinery. *Dioxin Study Report (NPDES Permit WA-000294-1)*. June 2004.
19. Tosco Refining Company Avon Refinery. *Dioxin Source Investigation Pursuant to Cease and Desist Order No. 95-151, Final Report*. April 1, 1997.
20. U.S. Department of Energy (DOE). *Petroleum Supply Annual 2000, Volume 1*. Energy Information Administration.
21. U.S. DOE. *Refinery Capacity Data as of January 1, 2001*. Data compiled from EIA-820, "Annual Refinery Report," Energy Information Administration. http://www.eia.doe.gov/oil_gas/petroleum/data_publications/refinery_capacity_data/refcapacity.html
22. U.S. DOE. *Water Use in Industries of the Future: Petroleum Industry*. Office of Energy Efficiency and Renewable Energy. Washington, D.C. July 2003.
23. U.S. Department of Health and Human Services. *Report on Carcinogens, Tenth Edition*. Public Health Service, National Toxicology Program. December 2002.
24. U.S. EPA. *1996 Preliminary Data Summary for the Petroleum Refining Category*. DCN 00402. Washington, D.C. April 1996.
25. U.S. EPA. *Alternative Disinfectants and Oxidants Guidance Manual*. EPA-815-R-99-014. Washington, D.C. April 1999.
26. U.S. EPA. *Development Document for Centralized Waste Treaters (CWT) Point Source Category*. EPA-821-00-020. Washington, D.C. August 2000.
27. U.S. EPA. *Development Document for Effluent Limitations Guidelines and New Source Performance Standards for the Petroleum Refining Point Source Category*. October 1982.

28. U.S. EPA. *Development Document for Final Effluent Limitations Guidelines and Standards for the Metal Molding and Casting (Foundry) Point Source Category*. EPA-440-1-85-070. October 1985.
29. U.S. EPA. *Emergency Planning and Community Right-to-Know Act Section 313 Guidance for Reporting Toxic Chemicals within the Dioxin and Dioxin-Like Compound Category*. EPA-745-B-00-021. December 2000.
30. U.S. EPA. *Emergency Planning and Community Right-to-Know Act - Section 313: Guidance for Reporting Toxic Chemicals: Polycyclic Aromatic Compounds Category*. EPA-260-B-01-03. August 2001.
31. U.S. EPA. *Exposure and Human Health Reassessment of 2,3,7,8-TCDD and Related Compounds. Draft Final Report*. EPA-600-P-00-001Bb. September 2000.
32. U.S. EPA. *Industry Sector Notebook: Profile of the Petroleum Refining Industry*. EPA-310-R-95-013. September 1995.
33. U.S. EPA. *Memorandum: Toxic Weighting Factor for Petroleum Refining Polycyclic Aromatic Compounds*. DCN 00646. December 11, 2003.
34. U.S. EPA. *PCSLoads2000*. Engineering and Analysis Division, 2004.
35. U.S. EPA. *TRIReleases2000*. Engineering and Analysis Division, 2004.
36. Washington State Department of Ecology (WA DOE), Letter of Transmittal. December 11, 2003 (DCN 00711): Tesoro Northwest study, May 2001; Cherry Point Refinery study, July 2001; and U.S. Oil & Refining study, August 15, 2003.
37. WA DOE. *Water Pollution Prevention Opportunities in Petroleum Refineries*. DCN 00405. November 2002.
38. Palmer, Breton, Nunno, Sullivan, and Surprenant. *Metal/Cyanide Containing Wastes: Treatment Technologies*. Noyes Data Corporation, page 390. 1988.

7.12 Petroleum Bulk Stations and Terminals

7.12.1 Introduction

In conjunction with the detailed review of the Petroleum Refining category, EPA also analyzed data associated with the Petroleum Bulk Stations and Terminals (PBST) Industry, SIC code 5171. Because of similarity of operations and wastewater characteristics, EPA studied PBSTs as a potential new subcategory of the Petroleum Refining category (40 CFR Part 419). This Section builds upon EPA's earlier study of the industry titled *Draft Profile of the Petroleum*

Bulk Stations and Terminals (PBST) Industry, March 3, 2003, which can be found at the EPA E-Docket. The earlier study is divided into several Adobe Acrobat files with Document ID numbers OW-2003-0074-0494, OW-2003-0074-0495, OW-2003-0074-0496, and OW-2003-0074-0497.

For this review, EPA verified TRI and PCS data from the year 2000, examined comments to the Preliminary 2004/2005 Effluent Guidelines Plan, contacted state and regional permitting and compliance authorities, conducted site visits, and met with industry groups in order to consider possible pollution prevention and wastewater treatment methods for PBSTs.

7.12.2 Data Sources

This section describes the data sources EPA used for the PBST study. This section also describes data quality limitations and verification activities. Section 4.2 of this document provides a general description of TRI, PCS, and U.S. Economic Census data sources. Section 4.2.4 discusses the calculation of toxic-weighted pound equivalents (TWPE) for certain data sources. This section discusses data sources specifically as they pertain to the PBST industry review.

7.12.2.1 Toxic Release Inventory

All PBST facilities with more than 10 employees that meet certain chemical threshold criteria must report to EPA's TRI program. Of the 9,104 PBSTs operating in the United States (1997 U.S. Census and other sources), 502 (5.5 percent) reported to TRI in 2000, with only 167 (1.8 percent) reporting discharges to POTWs and surface waters of the United States. As reported to TRI, the total estimated TWPE discharge in 2000 by PBSTs was 8,010 TWPE. Of the 167 PBST facilities reporting pollutant discharges to water, 125 discharged wastewaters directly and 27 discharged indirectly through POTWs, with the remaining 15 being both direct and indirect dischargers. The 125 solely direct dischargers accounted for 5,325 TWPE discharged, while the solely indirect discharging facilities discharged 8 TWPE. The 15 facilities that were both direct and indirect dischargers accounted for 2,677 TWPE discharged. As with other industries studied, EPA used TRI information to estimate pollutant loadings and to identify treatment technologies used within the industry. (1)

EPA reviewed TRI data, particularly for those facilities and pollutants which contributed significantly to the total TWPE estimate. For example, facilities may estimate releases in a number of ways, when reporting to TRI. If a chemical is not detected in the effluent, facilities may estimate the discharge by using one-half of the detection limit. This may overestimate the amount of chemical discharged.

Facilities report some chemical groups, including the 21 chemicals included in the PAC category to TRI. Facilities are required to report the combined mass of PACs released. They do not report releases of individual PAC compounds to TRI. For PBSTs, to calculate the TWPE of PACs reported in TRI, EPA used the toxicity weighting factor (TWF) for benzo(a)pyrene. See Section 4.4.4.3 for a more detailed discussion on PACs.

To verify the data reported to TRI, EPA performed the following activities:

- Confirmed that facilities reporting in SIC code 5171 were, in fact, PBSTs, through, for example, contacts with the relevant permit writers; and
- Reviewed comments submitted in response to the December 31, 2003 Preliminary Effluent Guidelines Program Plan.

Facility Specific Verification of TRI Data

The PBST reporting the largest TWPE discharges in the 2000 TRI database is the Coastal Oil of New England facility in South Boston, MA (NPDES ID MA0004405). The facility's discharges totaled 3,290 TWPE, driven by PACs and other petroleum hydrocarbons. These discharges total approximately 40 percent of the total TRI reported TWPE discharges for 2000. Through contact with Region 1, EPA learned that Coastal Oil ceased operations in 2000 (2). Since EPA's baseline for the industry's review was 2000, Coastal Oil's data are still in EPA's description of the industry. Nevertheless, the facility's current status significantly influenced EPA's final decision regarding effluent guidelines development for the industry.

Comment Received on the 2004/2005 Preliminary Effluent Guidelines Program Plan Pertaining to TRI

EPA received one facility-specific TRI-related comment from ConocoPhillips relevant to PBSTs. ConocoPhillips noted that its Kansas City Terminal, which reported discharges of more than 2,600 TWPE and ranked second in TWPE discharged in 2000, is co-located with the Kansas City Refinery, and shut down in 1983. Site remediation of the old refinery site includes groundwater remediation and discharge under an NPDES permit held by the Kansas City Terminal. ConocoPhillips asserted that the discharge of the treated groundwater accounts for the toxic discharges reported by the facility, as no process wastewater is discharged by the terminal and the only discharge associated with the terminal was stormwater. ConocoPhillips concluded by stating that the Kansas City Terminal's discharge of wastewater associated with site remediation should be eliminated from EPA's consideration of effluent guidelines for PBSTs.

After excluding the Kansas City Terminal's discharges from the PBST TWPE, ConocoPhillips explained that 61 percent of the TWPE discharge came from one facility and 94 percent from three facilities. Therefore, EPA should develop individual permits rather than national categorical ELGs.

Commenters also provided general comments on the TRI data itself. The Independent Liquid Terminals Association stated that TRI data show toxic discharges from PBSTs are minuscule, and five facilities accounted for 97 percent of the TWPE discharges. The American Petroleum Institute (API) noted that only six facilities in TRI reported the discharge of PACs, accounting for 99 percent of the industry's estimated TWPE discharges. In addition, API noted that 85 percent of the TRI TWPE discharges were due to two facilities in Massachusetts.

7.12.2.2 Permit Compliance System

States may submit data from PBSTs' discharge monitoring reports (DMRs) to PCS. The data from each DMR will vary depending on the PBST's NPDES permit requirements. Refineries that discharge to a POTW, or that transfer their wastewater to a private waste treater, do not submit DMRs; therefore, their data are not in PCS. In addition, PCS typically does not include data for refineries that states classify as "minor sources." Of the 9,104 PBSTs operating in the U.S. in 2000, data from eight (0.1 percent) PBSTs were included in the 2000 PCS. These eight facilities discharged 5,389 TWPE in 2000, with two reporters, Exxon Mobil's terminals in East Provide, RI (NPDES ID RI0001333) and Everett, MA (NPDES ID MA0000833) accounting for more than 99 percent of the reported TWPE discharges. (1)

To verify the data reported to PCS, EPA performed the following activities:

- Confirmed that facilities reporting in SIC code 5171 were, in fact, PBSTs, through, for example, contacts with the relevant permit writers and cross-checks with other databases; and
- Reviewed comments submitted in response to the December 31, 2003 Preliminary Effluent Guidelines Program Plan.

Facility Specific Validation of PCS Data

One of the eight PCS major facilities identified early in the screening process was Lyondell Chemical Company in Texas (NPDES ID TX0069493). EPA's contacts with the Texas Commission on Environmental Quality's (TCEQ) water permits office suggested that the facility was not, in fact, a PBST. EPA examined the Enforcement and Compliance History Online (ECHO) database, which reported that the facility was a PBST. EPA then reviewed the facility's TRI reports from 1997 to 2001 and the only reported SIC codes were 2865 and 2869. Given what EPA learned from TCEQ and older TRI reports, EPA concluded that the facility was not a PBST. As a result, EPA removed the PCS loads for Lyondell Chemical Company from the PBST industry's total loadings.

A similar discovery was made regarding the Texaco Guayanilla Terminal (NPDES ID PR0021024). As with the Lyondell Chemical facility, EPA concluded after cross-checking ECHO and the TRI reports from 1997 to 2001 that the facility was not a PBST. EPA, thereafter, removed its contribution to the 2000 PCS loadings for the PBST industry.

Comment Review

EPA received no PCS-related data from commenters and no comments from facilities requesting corrections to 2000 PCS data.

As with respect to the 2000 TRI data, however, commenters did address the PCS data itself. ILTA stated that, of the PCS majors, only two PBSTs discharge large amounts of

toxic organics and that both facilities are listed among the TRI reporting facilities. In addition, they asserted that these two facilities represent only 0.00187 percent and 0.0005 percent, respectively, of the total TRI loadings of 8,010 TWPE. As a result, they concluded that the toxic releases from those facilities are trivial.

API also addressed the PCS data by noting that, since only eight facilities are major dischargers, the majority of the industry is made up of minor dischargers. Moreover, they noted that the PCS data for major facilities show average discharge concentration of 16.9 mg/L of total conventional pollutants, 48 mg/L for total nonconventional pollutants, and 0.068 mg/L for total priority pollutants. API asserted that these concentrations are very low and reflect very effective wastewater treatment and low pollutant discharges. Finally, API concluded by stating that these effluent concentrations indicated that individual effluent discharges do not present a potential risk to human health and the environment.

7.12.2.3 Other Data Sources

EPA also collected data from several other sources, listed below:

- *Contacts with regional and state permitting and compliance authorities* - EPA contacted control authorities in the regions and states that contained the largest dischargers reporting to the 2000 TRI and PCS databases. EPA inquired about permitting issues for the industry, wastewater characteristics, how the industry handles its wastewater, and industry trends (3);
- *Contacts with treatment technology vendors* - EPA contacted treatment technology vendors to gather information on new options to reduce pollutant concentrations in PBST wastewater;
- *Industry-provided information/comments* - In response to the December 31, 2003 notice of the Preliminary Effluent Guidelines Program Plan, EPA received comments from ILTA, API, the Regional Citizens' Advisory Council for Prince William Sound (RCAC), Alyeska Pipeline, the Petroleum Marketers Association of America (PMAA), the New England Fuel Institute, the Independent Fuel Terminal Operators Association (IFTOA), the Department of the Navy, Amerada Hess Corporation, and ConocoPhillips.
- *Site visits* - EPA conducted site visits at two PBSTs, one at ConocoPhillips's Manassas, VA facility and one at Petroleum Fuel & Terminal Company's facility in Baltimore, MD.
- *Industry/trade association meetings* - EPA met with API and the Department of the Navy and several trade groups, including ILTA and PMAA (4).

7.12.3 Industry Description

The PBST industry is one part of the petroleum production, refining, and distribution system. These facilities are categorized by SIC code 5171 Wholesale Trade - Nondurable Goods, Petroleum Products, Petroleum Bulk Stations and Terminals. The PBST industry comprises establishments primarily engaged in the wholesale distribution of crude petroleum and petroleum products from bulk liquid storage facilities. Petroleum products handled by PBSTs include crude oil, gasoline, aviation gasoline, jet fuel (JP-4), diesel fuel, fuel oil, kerosene, naphtha, and lubricating oils. Specific types of PBSTs include:

- Bulk gasoline stations;
- Bulk petroleum stations;
- Crude oil terminals;
- Fuel oil bulk stations and terminals;
- Gasoline bulk stations and terminals;
- Heating oil dealers;
- Liquefied petroleum gas (LPG) bulk stations and terminals;
- Lubricating oils and greases bulk stations and terminals; and
- Oil, petroleum, and petroleum products bulk stations and terminals.

Bulk stations and terminals are part of the wholesale trade industry sector. Wholesale is an intermediate step in the distribution of the crude petroleum and petroleum products. The wholesale industry sells or arranges the sale of crude petroleum and petroleum products for resale by other wholesalers or retailers or for further production (intermediate materials). Establishments that sell crude petroleum and petroleum products directly include wholesale merchants, distributors, jobbers, drop shippers, import/export merchants, and sales branches. Establishments that arrange for the sale of crude petroleum and petroleum products (on a commission basis) include agents and brokers, commission merchants, import/export agents, and representatives of brokers, auction companies, and manufacturers. One commenter to the Preliminary Plan, ILTA, also noted that some PBSTs lease the use of their tanks to customers who own the stored product.

7.12.3.1 Industry Groups

Several groups represent facilities in SIC code 5171, many of whom commented on the Preliminary Plan. API represents the major oil companies and wholesale terminals, with about 400 members. PMAA is an umbrella organization representing small, independent bulk station owners and has 44 state and regional trade associations as members, representing about 8,000 marketers nationwide. PBSTs represented by PMAA typically have capacities ranging from 30,000 to 150,000 gallons. ILTA, another trade association, represents approximately 75 companies of all sizes, with about 500 facilities.

7.12.3.2 Industry Statistics

According to the 1997 Economic Census (Census), there are 7,690 PBSTs (defined under North American Industrial Classification System (NAICS) code 422710), 813 heating oil dealers (NAICS code 454311), and 601 LPG dealers (NAICS code 454312). SIC code 5171 includes all three NAICS codes, for a total of 9,104 facilities. In order to eliminate confusion, from this point onward, all 9,104 facilities will be referred to as ‘PBSTs’ in this report, unless otherwise noted. The Census data include statistics for three types of facilities:

- Merchant wholesalers - manufacturing sites that sell their own products;
- Manufacturers’ sales branches and sales offices - offices that sell products manufactured in the United States by their parent company; and
- Agents, brokers, and commission merchants - agents and brokers sell products from offices but do not handle or own the products; commission merchants sell and handle products on a consignment basis but do not own the products.

A majority (60 percent) of PBSTs have less than 10 employees and 99 percent have less than 100 employees. Over 90 percent of the facilities are corporations, with the remaining consisting of proprietorships and other entities.

The following table presents the geographical distribution of PBSTs (NAICS code 422710) reporting to the Census. Table 7-35 shows the petroleum storage capacity for the top 10 U.S. states, which account for over 50 percent of the total US. storage capacity. Similar data are unavailable for the 1,414 heating oil and LPG dealers.

Table 7-35. Geographic Distribution of PBSTs, per 1997 Economic Census

State	EPA Region	Bulk Stations (except LPG)	Bulk Terminals (except LPG)	LPG Bulk Stations and Terminals	Total
Texas	6	598	120	44	762
California	9	359	103	24	486
Louisiana	6	230	42	11	283
Missouri	7	262	15	4	281
North Carolina	4	233	31	10	274
Florida	4	194	52	26	272
Georgia	4	215	45	12	272
Illinois	5	217	33	14	264
Ohio	5	168	47	9	224
Indiana	5	169	33	16	218
Total for Top 10 States		2,645	521	170	3,336
Total for All States		6,045	1,225	420	7,690

PBSTs range in size from about 10,000 gallons to in excess of one million gallons, with the New England Fuel Institute noting in its comments to the Preliminary Plan that PBSTs typically handle on the order of 50,000 gallons of refined petroleum products. PBSTs may be co-located with refineries and may be located along coastlines to accept and treat large volumes of ballast water. Independent facilities are also reported to be widespread, with ILTA reporting that it represents approximately 500 facilities in the United States and 39 other countries (their American membership was not specified). PMAA, in its comments to the Preliminary Plan, reported that its membership of 44 state and regional trade associations represented nearly 8,000 independent petroleum marketers. The New England Fuel Institute asserted that it represented more than 1,000 stand-alone facilities not associated with any refinery. Along with privately operated PBSTs, the Federal Government operates bulk terminals as well. The Department of the Navy reported in an information submission to EPA that it operates 18 PBSTs across the United States (no facility, tank, or wastewater volumes were provided). In addition, in its comments to the Preliminary Plan, the Department of the Navy suggested that a more appropriate volume threshold for PBSTs would be between 50,000 or 100,000 gallons, noting that the definition for SIC code 5171 often encompasses the size of individual tanks at many Department of Defense facilities that serve as mobile fueling stations.

7.12.3.3 Discharge Status

EPA determined the discharge status of the PBST industry using TRI and PCS data. Table 7-36 lists the discharge status for PBSTs operating in the United States during 2000 and reporting to TRI or PCS.

Table 7-36. Facilities Reporting to TRI and PCS in 2000 and Their Discharge Status

Database	Facilities Reporting	Facilities Discharging to Water	Direct Dischargers	Indirect Dischargers	Direct and Indirect Dischargers
TRI	502	167	125	27	15
PCS	8	8	8	-	-

In the PCS data system, facilities may be classified as major or minor dischargers. States are not required to provide discharge data for minor facilities to PCS, so reports for minor facilities are incomplete. For this reason, EPA did not use data from minor facilities in this review and did not include them in the pollutant loadings estimates.

This table indicates that the vast majority of PBSTs do not discharge wastewater to waters of the United States.

7.12.3.4 Overview of Operations and Potential Wastewater Sources

The main function of PBSTs is to collect, store, and/or distribute product within the petroleum industry. As part of these operations, PBSTs may also perform tank cleaning, vehicle and equipment washing and maintenance, hydrostatic testing, product heating, and blending operations (i.e., adding additives to petroleum products). The product is collected from refineries or preliminary gathering stations and terminals using three means: pipelines, water transport, and rail transport. Pipeline systems are believed to be the most common, transporting the greatest volume of product nationwide through pipes of various sizes and capacities. Barges with divided sealed compartments transport product on rivers, canals, lakes, and oceans. Although not as common, rail transport is also a means of product delivery. Rail tank cars are often used for low-volume products (e.g., chemicals and lubricants) and typically have capacity for 20,000 to 40,000 gallons. PBSTs off-load materials and store the product in above ground storage tanks⁷ (ASTs) until distribution by tank trucks to service stations or other industrial and commercial operations.

Product Transfer Operations

The two main processes occurring at PBSTs are product collection and product distribution. Because product transfer areas and loading/unloading racks are areas susceptible to product leaks and spills, which could lead to violations of EPA's Spill Prevention, Control, and Countermeasures (SPCC) rules, they are specifically designed to minimize environmental release. They have sloped concrete floors that drain into a spill containment system and canopies that minimize rainfall entry into the transfer area. These precautions prevent accidental

⁷Underground storage tanks (USTs) may be used for loading rack spill containment and drainage systems. An UST system is a tank (or combination of tanks) and connected piping having at least 10 percent of their combined volume underground. UST regulations apply only to underground tanks and piping storing either petroleum or certain hazardous substances. EPA's Office of Underground Storage Tanks (OUST) web site provides further regulatory information. These regulations do not apply to ASTs.

spills from spreading beyond the transfer areas and minimize stormwater contact with product residues on the loading/unloading racks, thereby minimizing the volume of contaminated water in the spill containment system. Even with these precautions in place, most facilities also incorporate stormwater tank basins (i.e., stormwater collection tanks) with the capacity to contain any contaminated stormwater resulting from an accidental overflow or equipment failure.

Loading equipment such as piping, valves, and fittings are designed to be compatible with the type of product being handled and durable enough to withstand the stress of pressure and exposure to the elements. The pumps and loading devices are designed to allow appropriate flow of the type of product being transferred. Trained personnel or an automatic control system (or both) minimizes the spills and overflows that occur during product transfer.

Product Collection

PBSTs that receive product by pipeline use a network of pipes equipped with valves and pumps to transfer the product into storage tanks. Although the overall percentage of PBSTs receiving their products by pipeline was not known at the time of this report, a survey of 57 PBSTs conducted by API in 1988, showed that 63 percent received product by pipeline.

Barges and tankers delivering product are usually equipped with high-volume pumps and hoses for transferring product into the storage tanks via fill nozzles. Safe pressure is maintained during product transfer using bypasses or relief valves. The results of the 1988 API survey show that approximately 30 percent of facilities receive product from barges or tankers .

Rail tank car transfers take place in loading/unloading racks equipped with filling hoses or pipes that can be connected directly from the rail car to the storage tanks. Pressure relief systems are provided for the pumping system and the rail car itself. Rail tank cars are typically used to deliver more viscous products, such as lube oil; therefore, only a small portion of PBSTs typically receive product this way.

Product Distribution

Product is distributed from the storage tanks to service stations or other end-use facilities using tank trucks. Tank trucks typically have capacity for 5,000 to 12,000 gallons. Tank truck transfers occur in loading/unloading racks equipped with filling hoses or pipes and pump islands between the truck bays. Product can be transferred from the storage tank to the tank trucks using either top loading or bottom loading methods. There are two types of top loading methods: splash loading and submerged fill pipe loading. Significant turbulence and vapor/liquid contact occur during the splash loading method because the fill pipe dispensing the cargo is lowered only part way into the cargo tank. Liquid turbulence is relatively controlled during submerged loading because the fill pipe extends almost to the bottom of the cargo tank. The level of vapor generation and loss during submerged fill pipe loading is therefore much less than during splash loading. Top loading is most applicable for distillate products and asphalt

(more viscous products), and is discouraged for flammable liquids due to the potential to generate more vapors.

PBSTs most commonly use the bottom loading method because of reduced air emissions and improved safety. When product enters from the bottom of the tank, liquid turbulence, and therefore air emissions, are minimized. Furthermore, most bottom loading systems have vapor recovery systems in place to capture vapors and pipe recovered product back to the storage tank or to a thermal oxidation unit where the vapor is combusted. Approximately 10 to 30 percent of the displaced vapors never reach the recovery system due to collection system leaks; however, 90 to 99 percent of the product in the vapors that reach the vapor recovery system is recovered.

Product Storage

Between the product collection and distribution processes, the product is stored. PBSTs typically store product in vertical ASTs. Vertical tank storage capacities range from 500 to 300,000 barrels (bbls), or 21,000 to 12.6 million gallons. PBSTs also use horizontal tanks, or drums, for low-volume storage. For example, horizontal tanks are often used to store gasoline additives.

Depending on the volume and type of product stored, facilities use vertical tanks with a variety of roof designs and bottom constructions. Tank roofs can be fixed or floating, and tank bottoms can be cone-shaped, crown-shaped, or flat.

To control air emissions and to prevent product losses, product contamination, and fires, vertical tanks are equipped with one of the following roof types:

- Fixed roof - cover attached to the top of the tank, usually cone- or dome-shaped; includes a breather valve that allows the tank to operate at a slight internal pressure or vacuum;
- Fixed roof with internal floating roof - attached cover and internal roof that floats on the surface of the petroleum, rising and falling with the liquid level;
- Fixed roof with vapor recovery system - attached cover where volatile emissions (vapors) are captured and recovered;
- External floating roof - roof floats on the surface of the petroleum, rising and falling with the liquid level; and
- External floating roof with weather covers (aluminum domes) - cover is not attached to the tank, but provides additional protection.

Tanks with fixed roofs are closed vessels, and stormwater cannot typically enter these tanks. However, when product is placed in a fixed-roof tank, air must be released and treated to allow room for the product and prevent the tank from building too much internal pressure. Conversely when product is removed from a fixed-roof tank, air must be pumped in to fill its place and prevent the tank from collapsing. Fixed roof tanks are therefore a potential source of air emissions, but not water emissions.

Although floating roof tanks do not require removing and adding air during product transfer, they are more likely to allow stormwater to enter. Most of the stormwater collecting on the tank roof is drained through a tank drain; however, during heavy precipitation, or if a drain clogs, water may penetrate the roof seal and enter the tank. Floating roof tanks are therefore a contributor to the generation of tank bottom water, a source of contaminated wastewater.

Tank bottom water is not typically present at PBSTs in large volumes, but it is believed to be the major source of dissolved contaminants. Because there is much more product than water in a storage tank, the water can become highly concentrated with water-soluble materials in the product. The most common pollutants and bulk parameters/indicators in tank bottom water are as follows:

- Oil and grease;
- Total petroleum hydrocarbons (TPH);
- Biochemical oxygen demand (BOD);
- Chemical oxygen demand (COD);
- Total organic carbon (TOC);
- Ammonia;
- Total suspended solids (TSS);
- Phenols;
- Total dissolved solids (TDS);
- Naphthenic acids;
- Aromatics: benzene, toluene, ethyl benzene, and xylene (BTEX); and
- Surfactants.

The volume of tank bottom water generated is facility specific and depends on several factors such as number of tanks, tank volumes, the amount of precipitation, the products handled, and the temperature. Commenters and the industry noted that, since no general canvassing of the industry has ever been performed, estimating tank bottoms water volume is very difficult. In its 1988 study, API estimated that a moderate-size PBST has seven large storage tanks (100 foot diameter), and that one inch of water will accumulate in the bottom of the tank during a typical year. This converts to approximately 655 cubic feet of water (roughly 5,000 gallons) per year. If the concentration of a particular pollutant is 10,000 mg/L (0.084 pounds of pollutant per gallon of tank bottom water), almost 3,000 pounds of the pollutant needs treatment at the facility annually (approximately 420 pounds per tank). Most PBSTs will not attempt to handle this load all at once, and, in some cases, control authorities report that PBSTs

will, instead, draw the tank bottom water into an equalization tank and then gradually feed the water through a wastewater treatment system.

Many commenters to the Preliminary Plan noted that PBSTs often ship their tank bottoms water off site for treatment. Amerada Hess, PMAA, and the New England Fuel Institute stated that facilities will often send their wastes to others for treatment. In addition, ILTA and the County Sanitation Districts of Los Angeles County also noted that some PBSTs send their tank bottoms to refineries for reclamation of their petroleum fractions.

Tank Cleaning

Although not a frequent process at PBSTs, tanks are occasionally cleaned to remove accumulated sludge and residual product. While not usually emptied specifically for cleaning purposes, a storage tank may be cleaned if it is emptied for maintenance or if it is needed to store a different product. Tank cleaning requires removing and disposing of accumulated sludge, recovery and/or treatment of any tank bottom water, and treating of any detergents used for cleaning.

Vehicle and Equipment Washing and Maintenance

Vehicles and other product transferring equipment are sometimes washed on site at a designated area, resulting in wastewater contaminated with detergents and a small amount of product. Facilities handle this wastewater separately from other process wastes because of the potential to form emulsions when detergents and oil are mixed. Vehicle and equipment maintenance is also occasionally done on site, resulting in wastewater containing oil, antifreeze, brake fluid, or other vehicle fluids. This wastewater is also handled separately from other process wastes.

The percentage of PBSTs expected to use detergents to wash vehicles or equipment or to use brake fluid, antifreeze, lubricants, and other oils onsite for vehicle and equipment maintenance could not be estimated, given the data collected from industry and control authorities. As a result, an estimate of contributions toward total wastewater generation is not possible to make. However, of interest is Amerada Hess's comment to the Preliminary Plan stating that, of the nonstormwater component of PBST wastewaters, equipment and vehicle washing and maintenance waters are a primary fraction.

Hydrostatic Testing

Equipment at PBSTs is periodically checked for leaks by hydrostatic testing. This process involves filling the pipes or tanks with water, applying pressure, and searching for leaks. A high volume of water is discharged at the completion of the testing. Clean hydrostatic test water is discharged directly to a storm drain, but if hydrostatic test water is contaminated with product from the storage equipment, it typically undergoes treatment before it is discharged.

Neither control authorities nor commenters were able to provide any data to establish the volume of this type of flow. Amerada Hess and the County Sanitation Districts of Los Angeles County identified this as a possible contributor to PBSTs waste streams, but did not provide numerical data.

Product Heating

A PBST that stores heavy products (e.g. asphalt) needs to keep the product hot to maintain its fluidity. Steam coils placed in the product tank can heat the product with steam generated by a boiler. Most boiler feed water contains bicarbonate ions, resulting in the formation of acidic steam (carbon dioxide dissolves in condensed steam to make carbonic acid). The steam condensate is therefore corrosive and necessitates the use of chemicals, typically amines, to control the corrosion. As a result, amines may be present in the boiler wastewater stream. If the amines are not used and the steam coils corrode, steam may leak into the tank, come into contact with product, and become a source of tank bottom water.

Ballast Water Handling

PBSTs located along coastlines often also off-load ballast water from tankers transporting petroleum products, resulting in wastewater that is often contaminated with product. These wastewaters are normally rather dilute and very large in volume and usually undergo treatment before discharge. EPA is aware of one PBST that handles large volumes of ballast water as a result of comments submitted to the Preliminary Plan by Alyeska Pipeline and RCAC. Alyeska's facility treats and discharges approximately 10 million gallons per day of oily (0.5 to 1.0 percent oil) ballast water. The facility treats the wastewater with oil/water separation, dissolved air flotation, biological treatment, and, as needed, polishes with air stripping. The effluent concentration of oil and grease is typically 3-5 mg/L.

Wastewater Remediation Activities

Soil and/or groundwater under a PBST may be contaminated as a result of past terminal operations, current operations, or off-site contamination that has migrated on site. Groundwater is typically contaminated with dissolved hydrocarbons and is pumped to the surface, treated, and discharged. Soil may have total petroleum hydrocarbon contamination, requiring air sparging or soil washing. Control authorities in New England pointed to this as a widespread problem at PBSTs in their part of the U.S., though were unable to estimate wastewater flows as a result. In the case of New England PBSTs, many are very old and may have inadequate and compromised tanks. As a result, in many areas, mobile petroleum hydrocarbons like MTBE may find their way into the groundwater, rendering a need for remediation (5). As a consequence of these remediation activities, many PBSTs in the Northeast are moving to include granular activated carbon as a polishing step in their treatment systems.

Stormwater

Stormwater is defined as the portion of precipitation that becomes surface runoff (precipitation minus percolation and evaporation). The amount of stormwater generated at a PBST is dependent on several variables, including the size of the site (and more specifically the size of the process area), climatic conditions (taking into account spatial and temporal considerations), and the extent of pollution prevention practices in place to minimize the contamination of stormwater. Although most facilities use covered loading/unloading racks and geographical barriers (e.g., berms) to avoid contact between stormwater and contaminants in the process area, stormwater remains an issue for PBSTs because it represents the greatest volume of wastewater generated at most facilities. According to API's 1988 study, the average amount of stormwater generated annually per site (where more than 75 percent were less than 20 acres, and the remaining 25 percent were larger, typically covering 60 to 80 acres) was 20 million gallons.

API also attempted to quantify the average amount of stormwater at PBSTs of varying size and location, using the following assumptions: precipitation ranges from 10 to 50 inches per year, 100 percent of precipitation is runoff (no percolation or evaporation), and PBSTs occupy between 2 and 20 acres. Using these assumptions, API calculated that the smallest PBSTs (2 acres) in the driest regions (10 inches net precipitation annually) incur approximately 0.54 million gallons of stormwater per year, and the largest PBSTs (20 acres) in regions with the most precipitation (50 inches of net precipitation annually) experience approximately 27 million gallons of stormwater per year. Accordingly, the volume of stormwater is very site specific and year specific.

Although stormwater discharge volumes are site-specific, many commenters on the Preliminary Plan noted the overwhelming contribution of stormwater to PBST wastewater flows. Amerada Hess noted that stormwater runoff is the primary wastewater source at PBSTs, at nearly 95 percent of total wastewater discharge. The New England Fuel Institute stated that the only discharge from its member facilities to surface water is stormwater. IFTA, in its comments, asserted that PBSTs only discharge rainwater containing no more than trace amounts of oil, grease, and other pollutants.

Contaminated Stormwater

Stormwater that has come into direct contact with product (e.g., runoff from contaminated surfaces or loading/unloading racks) is contaminated, and therefore collected and treated before being discharged. API estimated that 0.6 percent of all stormwater (3,200 to 162,000 gallons per site annually, using the estimated volumes of 0.54 million gallons and 27 million gallons of stormwater per year) is contaminated.

Not all facilities have sufficient wastewater treatment facilities on site, and must send this contaminated stormwater off site to adjoining refineries, to waste disposal companies, or to regional treatment centers for treatment. Even if the stormwater is clean as it enters a tank basin, it may become contaminated in the event of an accidental product leak or spill into the basin. Facilities may treat this contaminated water by removing the floating oil alone, or may

need to remove dissolved contaminants, depending on the extent of contamination and the permit and/or POTW requirements. Floating oil is removed with floating skimmers or rope skimmers before any water is drained. Basin water containing dissolved contaminants is removed from the basin and treated as soon as possible to prevent migration of the contaminants to soil or groundwater (especially if the basin is comprised of permeable soil). Some PBSTs pump the contaminated basin water to a storage tank reserved for such situations. Other PBSTs may not have a spare storage tank onsite and instead pump the contaminated basin water into the bottom of a product tank for temporary storage.

Uncontaminated Stormwater

Stormwater that has not come into contact with product is said to be uncontaminated. If a facility determines that stormwater from a particular area onsite (i.e., the facility yard) has relatively no chance of contamination, it typically discharges the stormwater without collection and treatment, unless required by an NPDES or other discharge permit. API estimated that 98.3 percent of all stormwater (0.53 to 26.5 million gallons per site annually, using the best case and worst case volumes calculated above) is classified as having little chance of contamination because it runs over uncontaminated areas such as lawns, driveways, building roofs, parking lots, or undeveloped land.

If a facility determines that stormwater (or any other wastewater) collected in a tank basin is “clean” (i.e., has not come into contact with product or other contaminants), it can be discharged separately to a POTW or surface waters without treatment, or it can be combined with other treated wastewaters prior to discharge. Direct discharge to surface waters tends to be the easier and cheaper option if the water can be gravity drained to the final outfall. However, if the water must be pumped out of the facility, it is typically more cost effective to combine it with other treated waste streams for discharge to a POTW.

7.12.4 Regulatory Background

At this point in time, no national effluent guidelines regulate the discharge of pollutants from PBSTs. There are, however, several other EPA regulations that PBSTs have to comply with, and they are as follows:

- Clean Water Act Requirements;
- Clean Air Act Requirements;
- Resource Conservation and Recovery Act Requirements;
- Emergency Planning and Community Right-to-Know Act Requirements;
- Safe Drinking Water Act Requirements; and
- Regional and State Programs.

The following sections summarize these regulations.

7.12.4.1 Clean Water Act

PBSTs that discharge or have the potential to discharge wastewater containing regulated pollutants or other wastes (e.g., process wastewater, secondary containment water, and stormwater) must operate under the terms of federal, state, and/or local permits which include NPDES permits or POTW pretreatment agreements. These permits typically require wastewater monitoring, including amount of water volume discharged and generalized wastewater parameters (e.g., pH or specific pollutant concentrations).

In response to the 1987 CWA amendments, EPA established a program to address stormwater discharges. EPA developed NPDES stormwater permit application regulations to control the discharge of stormwater associated with an industrial activity (i.e., stormwater discharge directly related to manufacturing, processing, or raw material storage areas) (40 CFR Part 122.26(b)(14)). These regulations apply to stormwater from one of the 11 industrial activity categories defined at 40 CFR Part 122.26. 40 CFR Part 122.26(b)(14)(viii), listing transportation facilities of various types specifically lists facilities classified as SIC code 5171.

NPDES stormwater regulations require regulated facilities to obtain coverage under a NPDES stormwater permit and implement stormwater pollution prevention plans (SWPPPs) or stormwater management programs to effectively reduce or prevent the discharge of pollutants into receiving waters. Both the SWPPPs and stormwater management programs use best management practices (BMPs).

According to the U.S. EPA Integrated Compliance Information System (ICIS) retrieval component, the Online Tracking Information System (OTIS), over 700 facilities classified as SIC code 5171 have NPDES permits. NPDES permits for PBSTs usually regulate the discharge of oil and grease, naphthalene, toxicity, benzene, toluene, ethylbenzene, and xylene.

SPCC Plan

The SPCC rule (40 CFR Part 112) requires certain facilities to develop and implement oil spill prevention, control, and countermeasure plans. As part of the SPCC plan, facilities must install containment systems and other countermeasures to prevent oil spills from reaching navigable waters. If a facility is unable to provide secondary containment (e.g., berms around storage tanks), facilities must develop a spill contingency plan as part of the SPCC plan.

On July 17, 2002, EPA issued a final rule to amend the Oil Pollution Prevention regulation, specifically addressing requirements for SPCC plans. Changes to the SPCC rule include eliminating duplicate regulation, exempting certain small facilities and most wastewater treatment facilities, and requiring consideration of industry standards in prevention plans. Industry standards represent good engineering practice and generally are environmentally protective. Under the SPCC rule, EPA allows permit writers to apply industry standards where the standards are both specific and objective and their application may reduce the risk of discharges to and impacts to the environment. EPA allows the application of industry standards

due to technology advances and resulting specific standard changes. However, if industry standards change in a way that would increase the risk of discharge, EPA will apply and enforce standards and practices that protect the environment, rather than the less protective industry standard. Industry standards that may be used for the SPCC rule have been developed by organizations listed in the July 17, 2002 *Federal Register*, 67 FR 47058 (40 CFR Part 112). The changes to the SPCC rule are expected to reduce regulatory burden by approximately 55,000 facilities (40 percent).

The revised SPCC rule applies to PBST owners and operators with the following exemptions:

- Completely buried storage tanks subject to all of the technical requirements of the Underground Storage Tank (UST) regulations (40 CFR Part 280, 281);
- Portions of facilities used exclusively for wastewater treatment;
- Storage containers of less than 55 gallons (de minimis container size); and
- Aboveground storage tanks (ASTs) with capacity of 1,320 gallons or less (replacing the 660-gallon threshold).

On July 17, 2002, EPA issued a final rule addressing some requirements of SPCC plans and issued a schedule for facilities to come into compliance. As a consequence of litigation, on June 17, 2004, EPA proposed an extension to several of the compliance dates. A link to the Federal Register notice may be found at the following address:

<http://www.epa.gov/oilspill/pdfs/fr061704.pdf>

7.12.4.2 Clean Air Act

Facilities storing crude petroleum and petroleum products generate air emissions during loading and unloading operations and from normal tank breathing losses (collectively known as “working losses”).

The Clean Air Act (CAA) and the Clean Air Act Amendments (CAAA) of 1990 direct EPA to establish national standards for ambient air quality and enforce the standards through a variety of mechanisms. Regulations under the CAA and CAAA that may apply to storage terminals include the following:

- Title V permitting;
- New Source Performance Standards (NSPS); and
- National Emission Standards for Hazardous Air Pollutants (NESHAP).

According to EPA's OTIS database, the following number of facilities classified as SIC code 5171 have CAA permits:

- 546 major sources;
- 395 synthetic minor sources; and
- 191 federally reportable minor sources.

Major sources are defined by the CAA as stationary facilities that emit or have the potential to emit ≥ 10 tons of any one toxic air pollutant or ≥ 25 tons of more than one toxic air pollutant per year.

NESHAP

Facilities are subject to NESHAP if they are a major source of hazardous air pollutants (HAP) and emit 10 tons per year of a single HAP or 25 tons per year of a combination of HAPs. NESHAPs that apply to PBSTs include the following:

- 40 CFR Part 63 Subpart R: Standards for Gasoline Distribution Facilities (Bulk Gasoline Terminals and Pipeline Breakout Stations), promulgated December 1994; and
- 40 CFR Part 63 Subpart Y: Standards for Marine Tank Vessel Loading Operations, promulgated September 1995.

7.12.4.3 Resource Conservation and Recovery Act

The Resource Conservation and Recovery Act (RCRA) of 1976 addresses solid (Subtitle D) and hazardous (Subtitle C) waste management activities. Items to note regarding RCRA and PBSTs include the following:

- According to the Toxics Release Inventory (TRI) database, PBST releases include the RCRA hazardous wastes that are commercial chemical products designated with the code "P" and "U". 40 CFR Part 261.33 defines these wastes as acute hazardous wastes (code P) or toxic wastes (code U).
- EPA's OTIS database includes 2,301 facilities classified as SIC code 5171; these facilities have obtained RCRA permits.
- RCRA enforcement authority (Part 7003) is usually used to clean up petroleum plumes beneath storage terminals.

Subtitle C (40 CFR Parts 260-299) governs the handling of hazardous waste from the point of generation to disposal. Regulations for hazardous waste include waste

accumulation, manifesting, and recordkeeping standards. Permits under Subtitle C include general facility standards including the following:

- Contingency plans;
- Emergency procedures;
- Recordkeeping and reporting requirements;
- Financial assurance mechanisms; and
- Unit-specific standards.

RCRA requirements generally do not apply to specific industries, but rather apply to any facility that transports, treats, stores, or disposes hazardous wastes. In addition, RCRA also provides for the cleanup of hazardous waste releases or solid waste management unit releases (40 CFR Part 264, Subpart S and Part 264.10).

Possible RCRA wastes at PBSTs include tank bottoms water, oil/water separator sludge, and other wastewater treatment sludges. Under the Comprehensive Environmental Response, Compensation, and Liability Act (CERCLA), PBSTs must report any hazardous waste release exceeding the reportable quantity and becomes liable for the release cleanup. Note the definition of a hazardous waste under the RCRA statute does not include pollutants that are oil (of any kind, or in any form) or synthetic gases used for fuel. However, oil mixed with a hazardous substance is classified as a hazardous waste under RCRA.

At PBSTs, water may be found in contact and transported along with petroleum products. The fact that the water accompanies the petroleum product does not make the mixture of the two a waste, even though the water will ultimately be separated from the product and disposed of as a waste. The RCRA regulations define the point of waste generation as being “the point just beyond the step in which product is separated. Therefore, mixtures of petroleum products and water, “even if mostly water, can be classified as product, so long as there is legitimate recycling of product from the mixture”.

Most wastewater from PBSTs are not classified as hazardous wastes under RCRA. However, in 1990, EPA issued regulations (40 CFR Part 261.24) which classified any solid waste containing more than 0.5 mg/L of extractable benzene under conditions of the Toxicity Characteristics Leaching Procedure (TCLP) as a hazardous waste. In addition, water which contains more than 0.5 mg/L dissolved benzene is potentially classified as a hazardous waste. Typically, tank bottoms water from gasoline tanks and other sources at PBSTs contain more than 0.5 mg/L benzene, a component of gasoline. Exceeding the 0.5 mg/L limit for benzene requires PBSTs to handle and dispose of the waste in accordance with RCRA requirements. Note that RCRA regulations apply only to hazardous *wastes*, not to *products*.

In addition to benzene, there are also other contaminants that could be present in tank bottoms water, causing the water to potentially be classified as a RCRA hazardous waste at the concentrations listed in Table 7-37.

Table 7-37. Concentrations That Would Render Tank Bottoms Water a RCRA Hazardous Waste

Tank Bottoms Water Contaminant	RCRA Limit (mg/L)	PBST Contaminant Sources
Arsenic	5.0	Found in crude oils, water-soluble
o-Cresol	200	Made in refining, water-soluble
m-Cresol	200	Made in refining, water-soluble
p-Cresol	200	Made in refining, water-soluble
Cresols	200	Made in refining, water soluble
Lead	5.0	Used as a gasoline additive
Selenium	1.0	Found in crude oils, water-soluble

Wastewater that contains any of these contaminants above the RCRA limit concentration requires handling and disposal in accordance with RCRA requirements.

In addition to wastewater, there are also solid hazardous wastes that might be generated at PBSTs. These wastes will have the following characteristics as described in API's *Minimization, Handling, Treatment, and Disposal of Petroleum Products Terminal Wastewaters*:

- **Ignitability.** If the waste is ignitable (flash point less than 140°F) under the RCRA test conditions, then it will be hazardous. Some product-contaminated sludges may fall in this category.
- **Reactivity.** If the waste contains sufficient cyanide or sulfide to release more than the regulated amount of hydrogen cyanide or hydrogen sulfide when acidified, it will be hazardous. It is unlikely that PBSTs will generate reactive wastes from normal operations. However, since anaerobic biological activity converts sulfate to sulfide (by sulfate-reducing bacteria), it is possible that alkaline tank bottoms water stored for long periods of time might accumulate enough sulfide to fail the reactivity standard.
- **Corrosivity.** If the pH of the waste is less than 2.0, or more than 12.5, it will be classified as corrosive. Such wastes should be rare at PBSTs.
- **Leachability.** If more than regulated amounts of any chemical constituents are leached from the waste when it is subjected to specified leaching tests, it is hazardous. The regulated materials include toxic heavy metals and selected organic constituents. Possible materials that would fail this test are tank bottom sludge and wastewater treatment sludge. However, since heavy metals are not common at PBSTs and most of the regulated organic compounds are not expected to be in any petroleum products or wastes, PBST sludges will most likely pass this test. If wastes are derived from

leaded product storage tanks, or from removal of lead-based paint (e.g., spent blasting sand), then the waste could fail the lead leachability test. Also, benzene may appear in solid wastes at excessive levels as well as in wastewater (the wastewater disposal exclusions do not apply to nonaqueous wastes).

7.12.4.4 Emergency Planning and Community Right-to-Know Act

The Emergency Planning and Community Right-To-Know Act (EPCRA) provides community access to information about chemical hazards and facilitates the development of chemical emergency response plans by state and local governments. EPCRA regulations include the following types of reporting requirements for facilities that store or manage specified chemicals:

- Section 302 - facilities must notify the state emergency response commission (SERC) and local emergency planning committee (LEPC) of the presence of any extremely hazardous substances (listed at 40 CFR Part 355) above the substance's threshold planning quantity.
- Section 304 - facilities must notify the SERC and LEPC in the event of a nonexempt release exceeding the reportable quantity of a CERCLA hazardous substance or an EPCRA extremely hazardous waste.
- Sections 311 and 312 - facilities must submit material safety data sheets (MSDSs) and hazardous chemical inventory forms (Tier I and II forms) to the SERC, LEPC, and local fire department for hazardous chemicals in amounts exceeding a chemical use threshold. The list of hazardous chemicals is defined by the Occupational Safety and Health Agency (OSHA).
- Section 313 - facilities must submit an annual toxic chemical release form to EPA's Toxic Release Inventory (TRI) for a specified list of chemicals and chemical categories if the amount of chemical manufactured, processed, or otherwise used exceeds reporting thresholds. Only facilities in certain SIC codes (including SIC code 5171) and that employ 10 or more employees are required to report.

TRI requires facilities in SIC code 5171 to report the releases, transfers, and treatment of listed chemicals. This industry was added to TRI reporting beginning in 1998. Additional information on the types of pollutants and reporting criteria are available in the guidance document *EPCRA Section 313 Industry Guidance: Petroleum Terminals and Bulk Storage Facilities*, available on EPA's TRI web site: <http://www.epa.gov/tri/industry.htm>.

Based on number of employees, a majority of the PBSTs would not meet the first reporting criteria; therefore, the TRI database contains only a subset of the PBST industry. Recall that, in the TRI database for reporting year 2000, 502 PBSTs reported chemical releases.

7.12.4.5 Safe Drinking Water Act

The Safe Drinking Water Act (SDWA) authorizes EPA to establish health-based, national standards for drinking water. Part of the SDWA includes regulation of underground injection of waste fluids (liquids, gases, or slurries). Underground injection technology includes placing water, wastewater, or water mixed with chemicals into porous rock formations, injection wells, or other similar conveyance systems.

The SDWA classifies drywells or septic systems where PBSTs inject nonsanitary (i.e. nonsewage type) waste into the ground as Class V wells. To operate Class V wells normally does not require individual permits; however, users must submit inventory information to regulators (see 40 CFR Parts 144.24, 144.25, and 144.26). In addition, the water disposed of must not have the potential to cause contamination of the groundwater beneath the well where it becomes unfit for drinking, if used as or may be used as drinking water.

7.12.4.6 Regional and State Programs

As part of this study, EPA searched state web sites to evaluate current state NPDES permit regulations and to establish the availability of data on current PBST industry practices. The technology for treating PBST discharges typically includes oil/water separators to treat stormwater from secondary containment areas. Based on permits and regulations obtained for this analysis, states and regions apply a wide range of limitations and pollutant monitoring requirements to the PBST industrial category.

The following summaries describe the relevant NPDES general and individual permits that have been issued by EPA Regions and delegated states for PBSTs. Data are publicly available through state and EPA web sites.

Region 1

Connecticut:

Connecticut Department of Environmental Protection - Marine Terminals Program

The Department of Environmental Protection (DEP) Bureau of Waste Management licenses petroleum bulk storage facilities that receive product from, or dispense to, ships or barges. The application for this license requires detailed site information.

New Hampshire:

New Hampshire Department of Environmental Services - Application for the Construction of New and Substantially Modified Petroleum Aboveground Storage Tank Facility

The New Hampshire Department of Environmental Services requires a spill prevention plan for new and substantially modified petroleum stations and terminals. In addition to a spill prevention plan (SPP), the applicant must specify the manufacturer of the containment sump for aboveground piping over surface waters (marinas) and describe all secondary containment, including how stormwater will be handled.

Region 4

North Carolina:

North Carolina Department of Environment General Permit No. NCG080000 to Discharge Stormwater under NPDES

The North Carolina Department of Environment issues general stormwater permits through its Health and Natural Resources, Division of Water Quality. These permits cover stormwater point source discharges associated with activities that have vehicle maintenance areas (including vehicle rehabilitation, mechanical repairs, painting, fueling, lubrication, and equipment cleaning operation areas) associated with activities classified by specific SIC codes, including SIC 5171, with total petroleum storage capacity of less than one million gallons.

Table 7-38 presents limitations for oil/water separators and PBSTs:

Table 7-38. Sample Limits in North Carolina’s Stormwater General Permit

Parameter	Limitation and Units	Monitoring Frequency
pH	6.0 to 9.0 s.u.	Annually
Oil and grease	30 mg/l	Annually
Total suspended solids	100 mg/l	Annually
Total rainfall	Inches (report)	Annually
Storm event duration	Minutes (report)	Annually
Total flow	Million gallons (report)	Annually

South Carolina:

South Carolina Department of Health and Environmental Control NPDES
General Permit for Discharges From Bulk Petroleum Storage Activities
(SCG340000)

General permits issued by the South Carolina Department of Health and Environmental Control for discharges from bulk petroleum storage activities cover stormwater runoff from secondary containment structures (e.g., dikes and berms), stormwater and pad wash-down water from loading racks, and vehicle wash-down water. The only numerical permit limitation is for oil and grease. However, the permittee must monitor once per quarter for the following parameters:

- Flow;
- Ethylbenzene;
- Naphthalene;
- Copper;
- TOC;
- Toluene;
- Methyl Tertiary Butyl Ether (MTBE);
- pH;
- Benzene;
- Total xylenes; and
- Surfactants (only for vehicle washing).

Toxicity testing also must be conducted once per year using a 48-hour static acute toxicity test performed using a control and 100-percent effluent. The test is conducted on Ceriodaphnia according to South Carolina procedures for pass/fail modifications to EPA's standard methods.

Region 5

Ohio:

Environmental Protection Agency - Effluent Limitations and Monitoring
Requirements for Petroleum Bulk Storage Facilities

Ohio EPA established a monitoring program to characterize discharges from petroleum bulk storage terminals or similar facilities (i.e., large industrial facilities, airports, etc.). Petroleum bulk storage facilities are subcategorized as follows:

- Type A - Terminals with product loading/unloading racks.
- Type B - Terminals without loading racks (usually referred to as tank farms). Product transport is via pipelines only. Discharge of tank bottoms water is a potential.

- Type C - Terminals that are bulk crude oil storage and pipeline facilities. Crude oil arrives and leaves via pipeline; there is no loading or unloading of product or tank bottoms water.

Table 7-39 presents the parameters considered by Ohio EPA for developing permit requirements for each type of facility. Monitoring frequency is recommended to be once per month for all parameters, except phenol and naphthalene, which are recommended once per quarter.

Table 7-39. Parameters Considered by Ohio While Developing Permits

Parameter	Facility Type		
	A	B	C
Benzene	X	X	
Toluene	X	X	
Ethylbenzene	X	X	
Xylene	X	X	
BOD	X	X	X
COD	X		X
O&G	X	X	X
TSS	X	X	X
TOC	X	X	X
Phenol	X	X	X
Naphthalene	X	X	
Weather (report)	X	X	X
Precipitation (report)	X	X	X
Annual organic pollutant scan	X		

The only numeric limitations recommended are for oil and grease: 15 mg/l monthly average, 20 mg/l daily maximum.

Wisconsin:

Wisconsin Department of Natural Resources Petroleum Contaminated Water - WPDES General Permit No. WI-0046531-3

These WPDES general permits apply to point source discharges of wastewater that have been contaminated with petroleum, including, but not limited to: gasoline, diesel fuel, aircraft fuel, jet fuel, heating oils, and lubrication oils. Discharges are categorized into the following three types:

- *Petroleum contact water* (excluding tank bottom water) - technology-based limits assume use of adequately sized, designed, and functioning oil/water separator;
- *Tank bottoms water* - technology-based limits assume removal of dissolved or emulsified petroleum products from water including stripping, chemical addition, dissolved air floatation, activated carbon, activated clays, thermal treatment, and distillation; and
- *Scrap and waste storage area oily water* - technology-based limits assume the same treatment as for tank bottom water.

Discharges to groundwater and surface water have separate limitations for each of the three types of discharges, as shown in Table 7-40.

Table 7-40. Limitations by Discharge Type

Parameter	Petroleum Contact Water		Tank Bottoms Water		Scrap and Waste Storage Area Oily Water	
	Ground-water	Surface Water	Ground-water	Surface Water	Ground-water	Surface Water
Flow	Estimate	–	–	–	–	–
O&G	15 mg/l	–	–	–	–	–
Total BTEX	Monitor	–	750 ug/l	–	–	–
PAH	Monitor	–	0.1 ug/l	–	–	–
Naphthalene	–	–	8 ug/l	–	8 ug/l	70 ug/l
Benzo(a)pyrene	–	–	0.02 ug/l	0.1 ug/l	0.02 ug/l	0.1 ug/l
Benzene	–	–	0.5 ug/l	50 ug/l	0.5 ug/l	50 ug/l
Ethylbenzene	–	–	140 ug/l	–	140 ug/l	–
Toluene	–	–	200 ug/l	–	200 ug/l	–
TSS	–	–	–	–	40 mg/l	–
BOD	–	Monitor	–	Monitor	–	Monitor

Region 6

Arkansas:

Arkansas Department of Environmental Quality Authorization to Discharge
Under the NPDES and the Arkansas Water and Air Pollution Control Act
(ARG340000)

This authorization by the Arkansas Department of Environmental Quality applies to any facility that stores, in one or more stationary bulk storage tanks, petroleum and petroleum products; and subsequently transfers, distributes, or sells the petroleum and petroleum products

in large quantities, via pipeline, marine transportation, tank car, or tank truck, to the wholesale or commercial market. Six outfall types in the general permit with limitations as specified below:

- 101 Secondary containment areas (dikes) surrounding petroleum storage tanks;
- 201A Petroleum loading and transfer areas;
- 201B Petroleum loading and transfer areas and tank bottom water; nondischarge of tank bottom water directly to the diked area;
- 301 Petroleum tank truck wash water;
- 401 Petroleum tank truck garages located adjacent to petroleum storage and transfer areas; and
- 601 Containment stormwater runoff covered by or commingled with the above discharges.

Table 7-41 lists the above outfalls and applicable limitations.

Table 7-41. Arkansas Limits by Outfall Type

Parameter	Outfall					
	101	201A	201B	301	401	601
O&G	No free oil		10 mg/l (daily avg) 15 mg/l (daily max)			No free oil
Flow	Report					
pH	6.0 - 9.0 s.u					
Total BTEX	–	–	0.1 mg/l	–	–	–
TDS	–	–	500 mg/l	–	–	–
Ammonia (as Nitrogen)	–	–	1 mg/l (daily average) 2 mg/l (daily max)	–	–	–
Benzene	–	–	0.05 mg/l	–	–	–
Cyanide	–	–	0.005 mg/l (daily average) 0.009 mg/l (daily max)	–	–	–
Lead	–	–	0.0006 mg/l (daily average) 0.0012 mg/l (daily max)	–	–	–
Naphthalene	–	–	Report	–	–	–

Table 7-41 (Continued)

Parameter	Outfall					
	101	201A	201B	301	401	601
Acute Toxicity	–	–	>50% survival for 24-hr test on 100% effluent (1/month)	–	–	–
COD	–	–	–	50 mg/l (daily average) 75 mg/l (daily max)	–	–
TSS	–	–	–	35mg/l (daily average) 53 mg/l (daily max)	–	–

Texas/EPA Region 6:

Final NPDES General Permit for Discharges from Petroleum Bulk Stations and Terminals (TXG340000)

NPDES general permits issued by EPA Region 6 for the state of Texas apply to discharges of facility wastewater and contact stormwater from petroleum bulk stations and terminals and establishments primarily engaged in the cooperative or wholesale distribution of refined petroleum products or petroleum fuels from bulk liquid storage facilities. Table 7-42 lists the permit limitations.

Table 7-42. Texas General Permit Limits

Parameter	Daily Limit
Flow	Estimate (report)
Total petroleum hydrocarbons	15 mg/l
Benzene	0.05 mg/l
BTEX	0.5 mg/l
Lead	0.25 mg/l
pH	6.0 - 9.0 s.u.

In addition, discharges are analyzed once per year for the following parameters that have monthly average and daily maximum limitations:

- Arsenic;
- Barium;
- Cadmium (inland and tidal limits);

- Chromium;
- Copper;
- Manganese;
- Mercury;
- Nickel;
- Selenium (inland and tidal limits);
- Silver; and
- Zinc.

An acute toxicity test also must be conducted once per year using a 24-hour standard test on both *Daphnia pulex* and fathead minnows. Greater than 50-percent survival is required using 100-percent effluent.

Region 10

Oregon:

Oregon Department of Environmental Quality General Permit 1300-J

The Oregon Department of Environmental Quality general permits cover facilities storing, transferring, formulating, and/or packaging bulk petroleum products or vegetable oils, and other facilities with oily stormwater runoff and/or tank bottoms water. There are approximately 22 active facilities covered by these permits.

Stormwater discharges from bulk petroleum storage sites do not require permits if the total storage capacity at the site does not exceed 150,000 gallons and if the discharge from the containment area is treated by an oil/water separator. The discharge may not exceed water quality standards for oil and grease of 10 mg/l (monthly average) and 15 mg/l (daily maximum).

Facilities that are required to obtain an NPDES permit must meet the same oil and grease limitations. In addition, Oregon uses benchmark concentrations, shown in Table 7-43, to assess the site's Stormwater Pollution Control Plan.

Table 7-43. Oregon Stormwater Pollution Control Plan benchmarks

Parameter	Benchmark
Total Copper	0.1 mg/l
Total Lead	0.4 mg/l
Total Zinc	0.6 mg/l
TSS	130 mg/l
Floating Solids	No visible discharge
O&G	No visible sheen
pH	6.0 - 9.0 s.u.

7.12.5 Wastewater Characterization

This section presents wastewater characterization data based on TRI and PCS submissions for 2000. Using these data, EPA estimated total discharges from PBSTs and compared them to discharges from other industries.

7.12.5.1 TRI Data

Facilities report both direct discharges (i.e., mass of pollutant released directly to receiving streams) and indirect discharges before treatment (i.e., mass of pollutant transferred to POTWs) to TRI. For direct discharges, EPA used the reported mass to calculate TWPEs. For indirect discharges, EPA first estimated the reduction in pollutant mass accomplished by the POTW (i.e., pollutant percent removal) and then used the resulting mass of pollutant after treatment to calculate TWPEs discharged to the POTW's receiving stream. EPA calculated the reduction in pollutant mass for indirect discharges by using average POTW removal efficiencies (see DCN 00618, *Evaluation of RSEI Model Runs*).

The reported releases of PACs, n-hexane, and benzene comprise nearly 99 percent of the PBST industry's total toxic releases of 8,010 TWPE. Table 7-44 presents the pounds (and TWPE) discharged by direct and indirect dischargers as reported to TRI for the PACs, n-hexane, and benzene.

Table 7-44. TWPE Discharges of Individual Pollutants Based on 2000 TRI Data

Parameter	Facilities Reporting	Total Pounds Discharged	TWPE Discharged	Cumulative Percentage of Total TWPE Discharged (8,010)
PACs	5	35,293	7,741.21	96.6
n-Hexane	74	4,949	117.71	98.1
Benzene	109	4,033	63.53	98.9

7.12.5.2 PCS Data

Facilities report direct discharges (i.e., mass of pollutant released directly to receiving streams) to PCS. For direct discharges, EPA used the reported mass to calculate TWPEs. As discussed in Section 7.12.2.2, PCS includes only results of permit-required monitoring for direct discharging facilities. Even though toxic pollutants may be present in a refinery's discharge, they will not be reported unless required by permit.

The reported release of benzo(a)pyrene, benzo(b)fluoranthene, dibenzo(a,h)anthracene, and benzo(a)anthracene comprise more than 98 percent of the industry toxic releases of 5,389 TWPE, as reported to PCS. Table 7-45 presents the pounds (and TWPE) discharged by PCS major reporters for the four pollutants listed earlier.

Table 7-45. TWPE Discharges of Individual Pollutants Based on 2000 PCS Data

Parameter	Facilities Reporting	Total Pounds Discharged	TWPE Discharged	Cumulative Percentage of Total TWPE Discharged (5,389)
Benzo(a)pyrene	3	0.58	2,467.78	45.8
Benzo(b)fluoranthene	3	2.39	1,007.76	64.5
Dibenzo(a,h)anthracene	3	0.58	975.35	82.6
Benzo(a)anthracene	3	4.64	839.2	98.2

7.12.5.3 Stormwater Contributions to TRI and PCS Data

When reporting to the TRI, sites complete a Form R for each chemical exceeding the reporting threshold. Each chemical's Form R includes the pounds per year discharged in wastewater to receiving streams and water bodies for direct discharges (Section 5.3 of Form R). Sites also report discharges to POTWs and other off-site locations for wastewater treatment; however, only discharges to receiving streams or water bodies include reporting of the "% From Stormwater." Therefore, this analysis only applies to direct discharges. Moreover, this assessment will focus on those facilities whose TRI TWPE discharges ranked highest. The following four facilities discharged 96 percent of the 8,010 TWPE calculated from the 2000 TRI data:

- Coastal Oil of New England, South Boston, MA;
- Phillips Pipeline Co. Kansas City Terminal, Kansas City, KS;
- Irving Oil Terminals, Inc., Searsport, ME; and
- Noco Energy Corp., Tonawanda, NY.

Coastal Oil of New England did not provide any data linking toxic discharges to storm events. The other three facilities did, with Table 7-46 listing stormwater contributions to the discharge of various pollutants.

Table 7-46. Percent Discharges to Surface Waters Due to Stormwater for 2000 TRI Reporters

Parameter	Percent Discharged to Surface Waters Due to Stormwater		
	Phillips Pipeline, Kansas City, KS	Irving Oil Terminals, Inc., Searsport, ME	Noco Energy Corp., Tonawanda, NY
1,2,4-trimethylbenzene	22	100	100
Benzene	22	100	100
Ethylbenzene	22	100	100
n-Hexane	22	100	100
Methyl tert-butyl ether	22	100	100

Table 7-46 (Continued)

Parameter	Percent Discharged to Surface Waters Due to Stormwater		
	Phillips Pipeline, Kansas City, KS	Irving Oil Terminals, Inc., Searsport, ME	Noco Energy Corp., Tonawanda, NY
PACs	22	100	100
Toluene	22	100	100
Xylene (mixed isomers)	22	100	100

Of the eight PCS majors, four also reported to TRI in 2000. They are as follows:

- Exxon Mobil, East Providence, RI;
- ConocoPhillips, East Boston, MA;
- Shell Co., San Juan, PR; and
- Exxon Mobil, Everett, MA.

Exxon Mobil's East Providence, RI facility and Shell Co. reported no stormwater contributions to toxic discharges to surface waters. ConocoPhillips's East Boston, MA facility and Exxon Mobil's Everett, MA facility reported that stormwater was responsible for 100 percent of toxic discharges to surface waters for the following pollutants: benzene, ethylbenzene, methyl tert-butyl ether, toluene, and xylene (mixed isomers). In addition, Exxon Mobil's Everett, MA terminal also reported that 100 percent of n-hexane discharges to surface waters took place due to stormwater.

7.12.5.4 Wastewater Handling

The various types of wastewater are often handled differently. Any wastewater that has come into contact with product, particularly oil and grease and total petroleum hydrocarbons, is collected and treated in some fashion, sometimes on-site (oil/water separation, some form of primary and/or secondary treatment, e.g., biological treatment followed by granular activated carbon treatment), and disposal to a publicly owned treatment works (POTW), a lined lagoon, or direct discharge to surface waters. Several commenters to the Preliminary Plan stated that oil/water separation is widely used at those facilities that treat their wastewaters. ILTA went so far as to say that virtually all PBSTs that treat wastewater on site have oil/water separators. According to several control authorities, facilities that perform on-site treatment are generally larger. Their size and attendant economics make it easier for them to install and operate a treatment system. Many smaller facilities, on the other hand, have their wastes collected and shipped for off-site treatment at adjoining refineries or treatment facilities (3). The use of this practice was also widely reported by commenters.

Wastewater requiring primary and/or secondary treatment (because it is contaminated with oil and grease and total petroleum hydrocarbons) is typically tank bottom water, loading/unloading rack water, a portion of the tank basin water, wastewater generated during remediation, and water used for hydrostatic testing, if it is contaminated (if hydrostatic

test water is not contaminated, it is normally released to a storm drain). In the case of tank bottoms water, commenters report that it is normally sent off site for treatment. For example, Amerada Hess reported that all of its terminals ship tank bottoms water off site for treatment. Wastewater that contains surfactants or other types of cleaning agents is not commingled with other oily wastewaters to prevent the formation of emulsions; therefore, wastewater from vehicle and equipment washing and maintenance, as well as wastewater from lavatories, is typically discharged separately to the POTW. Stormwater runoff from the facility yard, roofs, and drives, as well as some of the tank basin water, is either collected and examined (visual inspection and/or chemical testing), or released to the environment without collection if the facility ensures that the water has had no contact with product or other pollutants. If collected stormwater is clean, it is sent to a storm drain; otherwise, it is sent through oil/water separation and other necessary treatment measures before being discharged to a POTW, a lined lagoon, or to surface waters.

7.12.6 Pollution Prevention Practices

Pollution prevention practices reduce pollution at the source. This includes any practice that reduces the amount of pollutants entering any waste stream or otherwise released into the environment prior to recycling, treatment, or disposal and reduce the hazards to public health and the environment. Pollution prevention practices include equipment or technology modifications, process or procedure modifications, reformulation or redesign of products, substitution of raw materials, and improvements in housekeeping, maintenance, training, or inventory control. As discussed in Section 7.12.3, there are several sources of wastewater at PBST facilities; however, there are also many pollution prevention practices that can be implemented to reduce or eliminate these sources of wastewater. In addition to the environmental benefits of pollution prevention, PBST facilities can benefit from implementing pollution prevention practices by doing the following:

- Reducing the size of downstream wastewater treatment equipment;
- Providing a permanent solution for eliminating pollutants;
- Eliminating costs associated with managing wastewater; and
- Providing more reliable methods for eliminating pollutants.

This section describes the following pollution prevention practices that can be implemented to reduce or eliminate wastewater generation at PBSTs:

- Section 7.12.6.1 discusses the pollution prevention practices that minimize stormwater contamination;
- Section 7.12.6.2 discusses pollution prevention practices that minimize generation of wastewater; and
- Section 7.12.6.3 discusses pollution prevention practices for reducing other wastewater sources.

7.12.6.1 Stormwater Pollution Prevention Practices

Stormwater is the major source of wastewater volume at most PBST facilities. Stormwater can be divided into three categories – uncontaminated, potentially contaminated, and contaminated – based on the type of area from which the stormwater is generated. To minimize the amount of wastewater that requires treatment, PBSTs should segregate stormwater from sources of contamination and take preventive measures to minimize potential stormwater contamination.

Stormwater Segregation

To minimize the amount of wastewater generated, PBSTs should segregate stormwater from sources of contamination so that it can be discharged with minimal or no treatment. Two methods to segregate stormwater from potential sources of contamination are geographical segregation and roof design. Both of these methods help prevent contamination of stormwater by pollutants from PBST facilities and dilution of contaminated water.

Geographical Segregation

Geographical segregation prevents mixing of different categories of stormwater (i.e., uncontaminated, potentially contaminated, and contaminated), using a combination of the following methods:

- Grading: moving dirt to form land slopes such that water flows in the desired direction;
- Berms: elevated barriers used to contain and control surface water movement;
- Interceptor drains: collection channels (e.g., ditches or sewers) that capture a type of runoff before it can mix with another type; and
- Curbs: elevated barriers to contain and control surface water movement that are low enough to allow for personnel and equipment to move over them.

To implement geographical segregation, the facility must identify which plant areas generate each of the three types of stormwater. If a facility determines that different types of stormwater are commingling, it can use the geographical segregation methods listed above to segregate the stormwater, enabling the facility to reduce the amount of stormwater that requires treatment.

Roof Design

Facilities can provide roofs over potential sources of contamination, with the runoff from the roofs sent to a less-contaminated area. The primary use of roofs is on storage tanks because tank bottoms water is highly contaminated, but has very low flow if stormwater is segregated. For tanks that contain water-soluble materials (e.g., gasoline oxygenates and fuel and lubricant additives), fixed roofs are recommended because water mixing with such materials can significantly contaminate and degrade product quality.

Roofs (or canopies) can also be used over transfer racks to segregate stormwater from small product spills that result when making and breaking hose connections to transport vehicles. These canopies also protect personnel from the elements and keep stormwater out of the transport vehicle. To prevent stormwater runoff from flowing over the facility slab, roof drains should be routed away from the slab and the slab should be surrounded by rollover curbs. In addition, this area should have a drainage and containment system which drains to a sump and is routed to the proper treatment system. This system should also be designed to hold the maximum capacity of the largest compartment of a tank car or truck used at the facility in the event of tank rupture or accidental overflow.

Pump stations are considered contaminated areas because of pump seal leaks and pump maintenance discharges. PBSTs can place a roof or canopy over the pump station to eliminate stormwater collection and treatment from the pump station slab. These roofs are similar to the roofs placed over transfer racks.

A novel possibility of this type is the use of green roofs. Green roofs, sometimes called roof gardens, are a surface treatment for rooftops involving the addition of several layers of growth media and plants to create a contained green space. Current green roof design is generally comprised of four components: a waterproof membrane, a drainage layer, a growth medium, and vegetation. Variations in these components, including the addition of a vegetation support layer above the growth medium can greatly affect the water flow and thermal characteristics of the green roof. Proponents of green roofs have claimed numerous benefits including improved air quality, stormwater attenuation, reduction of the “heat island effect,” and aesthetic value (6). While EPA is unaware of any PBSTs that use this technology, EPA is aware of other industrial structures in the United States that use green roofs. The most prominent of these is the Ford Automobile Company’s Rouge Center in Michigan, which installed a green roof approximately two years ago. While Ford is, as yet, unable to provide performance data, the possibility remains intriguing. In the case of PBSTs, the technology is probably not appropriate for direct usage on tank roofs, but might be used on canopy roofs. A potential hurdle, from the standpoint of design, is adequate load-bearing capacity.

Minimizing Stormwater Contamination

Potentially contaminated stormwater is collected and subjected to minimal treatment before discharge; if it becomes contaminated, it must be treated more extensively. To

reduce the amount of contaminated stormwater, steps can be taken to reduce the probability of contamination.

Stormwater at PBSTs may be contaminated by accidental release of materials to the ground, including leaks in piping or tanks, overfilling the tanks, accidentally opening tank nozzles, or tank cleanout activities. See Section 7.12.6.2 for descriptions of methods to minimize these releases. When such releases do occur, there are preventative measures that can minimize the likelihood of stormwater contamination.

Petroleum tanks are surrounded by a containment area, bounded by dikes or walls. It is a general rule that the containment area is able to hold the volume of the largest tank in the area without spillover. Rainwater is removed from the contained area via drainage pipes with shutoff valves that are placed through the dikes or walls. The shutoff valves should be closed at all times except during attended rainwater drainage. If a product spill occurs at the same time that rainwater accumulates in the tank basin, then the clean water can be drained using “turndown ells” on the basin end of the pipe. These devices allow water to drain while minimizing entrainment of floating product.

7.12.6.2 Minimizing Generation of Wastewater

There are several ways that product can become mixed with wastewater at a PBST, including petroleum product discharges into wastewater, product/water emulsion, and tank bottoms water accumulation. Pollution prevention practices are available to reduce or eliminate product contamination in wastewater streams.

Petroleum Product Discharges

Product discharges can enter wastewater through petroleum product tank bottoms draws, waste product discharge, equipment drainage, sampling episodes, leaks, tank deterioration, and product transfer mishaps. Using appropriate pollution prevention practices can reduce or eliminate all of these sources of product discharge.

Removal of Tank Bottoms Water

Water from various sources collects in the bottoms of petroleum product tanks (see Section 7.12.5.2). This wastewater must be removed to ensure that water is not being mixed with product as it is pumped from the tank; this method is termed product tank bottoms draw. Once it is removed, this wastewater is sent to a collection tank for oil separation and treatment. Facilities should use methods such as water volume determination, water/product interface detection, and product entrainment prevention that maximize the withdrawal of water while minimizing the withdrawal of product.

The facility should first determine the amount of water in the tank to ensure that the minimum amount of water is drawn. One way is by gauging the tank with a tape or stick coated on its lower end with water-indicating paste, which changes color when it comes in

contact with water. Another way is to position closely spaced trycock valves on the side of the tank. These valves should be situated where the water accumulation is expected. Facility personnel can determine the water level by opening the trycock valves (starting with the lowest one) to assess the highest one that delivers water.

A third method for detecting the water/product interface is using sight glasses mounted on the side of the tank. The upper end nozzle of the sight glass should be placed lower than the level of the product; otherwise, there will be no correlation between the interface level in the sight glass and the interface level in the tank. Calibration curves (or tank strappings) show the relationship between tank water level and tank water volume and can be used to determine the volume of water to remove once the level is known. Manual control is another method of interface detection, where the water draw valve is manually opened, the drawn substance is sampled, and once product is detected, the valve is manually closed.

There are more reliable methods of detection that rely on the properties that distinguish water from product, such as detectors based on electrical conductivity or capacitance and devices using a float of exact specific gravity to control a shutoff valve. If the volume of the water in the tank is known, facilities can use a device that meters the draw volume and operates a shutoff valve when the determined wastewater volume is reached. Unfortunately, fouling could be a concern for these three methods. Another technique is to draw water through a canister of material that swells when contacted by hydrocarbon, and consequently blocks the flow once product is drawn.

Product entrainment is defined by API to be the carryover of droplets of product in a water draw flow. Facilities can minimize product entrainment using proper design guidelines and operating procedures. For example, a water sump can be situated in the tank bottom next to the water drain nozzle and the nozzle to the tank interior can be connected with a turndown ell. This method ensures that the water is taken from the lowest possible elevation (i.e., farthest away from the water/product interface). Facilities can also use vortex eliminators or vortex barriers to keep the product from being pulled down in a swirling vortex. Another method is to place the product draw nozzle at the highest possible elevation because if there is a large separation between the product and water draws, then some water can remain in the tank to avoid drawing in some product. In addition, facilities can control product entrainment by the water draw rate. Product entrainment and overshooting the water/product interface is more probable at high water flow rates. Facilities should also reduce the water draw frequency.

Discharge of Waste Product

Slop oil (or waste product) is any petroleum product that does not meet product specifications and cannot be used or distributed as is. Slop oil systems can eliminate waste product discharge into wastewater sewers. PBST facilities can use these systems to collect waste product and reuse it. Slop oil systems are comprised of collection points that are situated at all sources where waste product is generated. If small volumes of waste product are generated, the slop oil system may be a collection drum. If facilities generate large volumes of waste product, then they should use a direct pipe connection from the system. For intermediate volumes, an oil

sump can be placed at a lower elevation than where product is released to enable gravity drainage. Water should not enter the slop oil system. The waste product can be transported for further processing using piping, vacuum truck, or truck transport of filled slop oil drums, where it can be converted into a useful product by separating and removing the water.

Equipment Drainage

When equipment is taken out of service for maintenance, it is typically drained. Equipment usually contains large amounts of product, so draining this product into sewers can cause wastewater contamination. The most common pollution prevention practices for minimizing product drainage into sewers are design factors, including avoiding pocketing, using drain nozzles, and providing a collection point.

To avoid pocketing (i.e., product trapped in low points in the piping that is not able to drain in either direction), when a process is stopped, the product in the equipment should flow out of the system through existing equipment. For example, vessels should have drain lines at their low points with connections that enable the contents to be pumped or gravity drained to other parts of the system. In addition, piping should not have pockets that cannot be drained by gravity in either direction. If there are pockets in the system, then drain nozzles should be used with a shutoff valve at the pocket. The drained product can be used, rather than washed into a sewer. One way to recover the drained product is to run hoses from the drain nozzles to a below-grade product collection sump. The product can be transferred from the sump to the slop oil system by vacuum truck or with a sump pump and piping system. An alternative method is to connect the drain nozzle directly to a vacuum truck suction hose.

Product Sampling

PBSTs typically use sampling nozzles and stations to collect samples at different points. Because the sample nozzle piping normally has no flow (i.e., dead volume), it is general sampling protocol to open the sample valve and allow the substance to flow long enough to purge the piping of dead volume to obtain a representative sample. This dead volume is sometimes discharged into the oily wastewater sewer, which contaminates the wastewater with product. Installing a sampling loop or a sample trough can eliminate this discharge.

A sampling loop is a loop of piping where the pipe's upstream end is connected to the normal sample collection point and its downstream end to a lower pressure region of the same process. When a sample is taken, the sample loop is purged by opening the sample loop line valves, and then the sample nozzle is opened to collect the sample. Another pollution prevention practice is using a sample trough, which is a collection sink or trough at the sample nozzle, connected to the slop oil system.

Leaks

Leaks can be a major source of product in wastewater and stormwater. There are various types of leaks, such as pump seal leaks, valve seal leaks, and piping leaks, for which pollution prevention practices can be implemented.

Pump seals are found on the rotating shaft in rotating pumps and on the piston in piston pumps. A certain amount of leakage is required to lubricate the seal for many rotating seals. Pollution prevention practices to minimize leakage include considering product leaks as a factor in pump selection, selecting mechanical seals instead of packing seals, and selecting seal-less pumps over ones that use seals. In addition, pump seals should be maintained in good condition; therefore, when product leakage from seals becomes excessive, they should be tightened, repaired, or replaced.

Valve seals are used to minimize process fluid leakage along the stem that connects the internal parts with the external actuator. These seals can leak, so to minimize product release, PBSTs should choose valve designs that minimize leakage and maintain valve seals in good condition.

Unlike pumps and valves, piping leaks are not inherent to the equipment design and typically result from improper assembly or corrosion. To prevent piping leakage, PBSTs should hydrotest equipment that is taken down for maintenance before returning it to service. In addition, if buried piping is metal, it should have a protective wrapping and coating. Cathodic protection may also be necessary. For aboveground pipes, facilities should post signs and inform drivers at the facility about the presence of these pipes to avoid accidental spills from collisions .

Tank Deterioration

Tanks can deteriorate over time causing leaks and rupture, so they should be designed correctly and inspected periodically. As described in the SPCC requirements, tanks should be selected based on their suitability for the material being stored and the storage conditions. Industry standards should be followed for the construction, material, installation, and use of the tank. Fiberglass tanks should be used underground because they do not corrode. If metal underground storage tanks (USTs) are used, then they should have corrosion resistant coating, cathodic protection, or another effective method of protection from corrosion. Trained personnel should inspect aboveground storage tanks (ASTs) to detect leaks or other deterioration. Inspectors may use X-ray or radiographic analysis to determine the wall thickness and detect cracks and crevices in metal; ultrasonic analysis to measure the shell metal thickness; hydrostatic testing to identify leaks caused by pressure; visual inspection to detect cracks, leaks, or holes; and magnetic flux eddy current test and ultrasonic analysis to detect pitting. Corrosion can be prevented in metal ASTs by using dielectric coatings, cathodic protection, and double-bottom tanks.

Product Transfer Mishaps

Wastewater and stormwater can become contaminated by-product transfer mishaps, such as tank overfilling and accidental opening of nozzles. Gauging the tank before it is filled and monitoring the tank while it is being filled can prevent tank overfilling. High-level alarms and automatic shutoffs can also prevent tank overfilling. Establishing a policy to keep blind flanges or caps over all pipe openings and unconnected valve ends can minimize accidental releases caused by accidentally opening tank nozzles.

Controlling Emulsions

An emulsion is the dispersion of product in water or vice versa. The phase in which the droplets are dispersed is the continuous phase and the droplets comprise the dispersed phase. Since petroleum product is separated from wastewater by gravity separation, there are serious adverse effects on wastewater quality when product cannot be gravity separated from wastewater. Emulsions typically accumulate at the product/water interface because their density is in between the densities of the product and water. The PBST industry typically refers to these emulsions as rag or cuff. Pollution prevention practices that minimize product/water emulsions involve product droplet control, surfactant control, and fine solids control.

Product Droplet Control

Emulsions are stabilized by small oil droplets because they are inherently slower to separate from the continuous phase. Small oil droplets are formed by agitation of oil and water, which is caused by pumping product/water mixtures or turbulent flow of product/water mixtures. Centrifugal pumps are frequently used by PBST facilities and generate emulsions because the material pumped is subject to high agitation in the pump. To minimize emulsions, facilities should use positive displacement pumps (e.g., gear pumps, piston pumps, diaphragm pumps, and Archimedes screw pumps) because they produce less agitation and therefore less emulsions. Emulsions are also formed by turbulent flow of product/water mixtures, which can be caused by high velocities of fluid flow in pipes or ditches. Pollution prevention practices such as increasing pipe diameter, restricting the gravity gradient, and avoiding sudden changes in elevation avoid turbulence in oily wastewater streams by maintaining low velocities.

Surfactant Control

Emulsions are also stabilized by surfactants (e.g., detergent and soaps) collecting at the product/water interface, which reduce the surface tension and inhibit phase separation. Natural surfactants are present in crude oil; however, manufactured detergents used for cleanup or as gasoline or lube oil additives are of most concern at PBST facilities.

PBSTs use detergents to clean oily equipment. To minimize the formation of emulsions, facilities should use the minimum amount of detergent necessary. Another method is to use nondetergent alternatives, such as dry cleaning methods (e.g., solvents or absorbent materials for spilled product) or steam cleaning.

Gasoline additives can contain detergents that keep vehicle fuel systems free from deposits. To prevent emulsions from forming, gasoline additives or gasoline containing additives should not come into contact with water; therefore, PBSTs should keep these substances in waterproof tanks.

Some PBSTs accept water-containing, off-specification products with additives (which aid in the formation of emulsions) from service stations. For this source, pollution prevention practices include keeping these products separate from other products until all water is separated; using a low-flow tank if the recovered product is sent to a product tank; and not mixing the water separated from haulback material with oily wastewater.

Fire foam systems are tested occasionally at PBSTs. Releasing foaming agent surfactants dissolved in water can cause product/water emulsions to form. Physically cleaning up the foam (instead of washing it down), selecting a foaming agent that is compatible with the treatment system (e.g., it is biodegradable if biotreatment is used), and segregating the foam wastewater from oily wastewater can minimize the release of these surfactants and thereby reduce the possibility of forming emulsions.

Fine Solids Control

Fine solids can generate product/water emulsions by contacting and being saturated with product and water simultaneously. Fine solid sources include soil, powdered materials, and corrosion products.

Soil erosion is a common source of fine solids at PBSTs, and clay soils produce very fine particles. To prevent emulsions from forming from this source, facilities should minimize the erosion of soil into wastewater collection systems by segregating runoff areas, planting groundcover plants, paving the drainage area, and using geofabrics.

PBSTs occasionally use powdered materials, such as spent blasting sand. To prevent emulsions from forming from this source, facilities should properly store these materials to prevent them from entering stormwater and wastewater sewers. If these materials are deposited on paved areas, they should be removed by dry methods, such as sweeping instead of washing it down.

Fine solids can also be generated from sulfide corrosion of steel, which creates very fine iron sulfide. Facilities should remove these fines from process equipment without mixing product, water, and solids.

In general, to keep solids from entering oily wastewater streams, facilities should use closed sewer or pipes instead of open ditches to convey wastewater. Also, facilities should segregate sanitary wastes from oily wastewater because these wastes contain biosolids and detergents that stabilize emulsions. To do this, facilities can send sanitary waste to a municipal sanitary sewer, a septic tank, or other dedicated sanitary treatment system, or mix the sanitary waste with oily wastewater only after oil/water separation.

Tank Bottoms Water Accumulation

According to API, product tank bottoms water is the most expensive wastewater to treat because it is by far the most contaminated wastewater generated at PBST facilities. Therefore, it is important to minimize this source of wastewater by reducing the tank bottoms flow, the amount of entrained product water, tank breathing and condensation, rainwater, and other sources.

Reduction of Tank Bottoms Flow

A pollution prevention practice that can be implemented at PBST facilities is reducing the flow of tank bottoms water to minimize the amount of contaminant transfer from petroleum products. This method affects wastewater contaminants in different ways depending on the solubility of the contaminant. Entrained contaminants are drained along with the water; therefore, reducing the amount of wastewater will proportionately reduce the discharge of entrained product. Saturated contaminants are present at high concentration in products and are not readily soluble in water. Because these contaminants will have the same concentration regardless of the amount of water and product, the mass flow of these contaminants is directly proportional to the water flow. Extractable contaminants are somewhat soluble in both water and product. These contaminants are able to partition in both the product and water phases; therefore, reducing the wastewater flow, can reduce the discharge of these contaminants. Water-borne (or water-soluble) contaminants are not expected to be soluble in products; therefore, these contaminants are not affected by reducing tank bottoms flow rates. To reduce this type of contaminant, facilities should reduce the source of water-soluble contaminants into the tank.

Reduction of Water Entrained in Product

A significant source of tank bottoms water is water entrained in the products. This water is highly contaminated with water-soluble contaminants. Some procedures that can minimize entrained water at PBSTs include reducing water in products delivered from tankage, establishing distribution chain procedures, setting product specifications, and requiring take-back of delivered water. In addition, there are some techniques that can be used to reduce or eliminate entrainment of water.

PBSTs can reduce or eliminate entrainment of water in products delivered from tankage using the same methods for reducing the amount of water drawn from a tank. These methods include installing nozzles that draw the product as high as possible above the maximum water level expected, keeping the tank water level as low as possible, removing tank water before removing product, and using turned-up water nozzles that minimize entrainment of water.

Establishing distribution chain procedures from the refinery through the product distribution chain can also minimize water content in product. In addition, PBSTs can set product specifications for water or contaminants in product received at the terminal. PBSTs can also return water delivered with the product to the originator, which gives originators incentive to reduce the amount of water entrained in the products.

Reduction of Tank Breathing and Condensation

According to API, tank breathing air and condensation are minor sources of water in tanks, and it is difficult to minimize or remove these water sources.

Reduction of Rainwater

Rainwater is a major source of tank bottoms water. It can be reduced or eliminated by installing fixed roofs on the tanks. If floating roofs are used, then the roof seals should be replaced or repaired periodically and floating roof drains should be cleared of blockage.

7.12.6.3 Pollution Prevention Practices for Reducing Other Sources of Wastewater

Rack cleanup water is generated when product spills, product drips, and accumulated dirt are rinsed from the equipment and/or slab. Facilities can reduce this source of wastewater by using dry cleaning methods, such as absorbent granules or fabrics and wiping or sweeping equipment. If washing is the only feasible option, then the minimal amount of water should be used. Additionally, PBSTs should minimize the use of detergents by tracking the amount of detergent used by each operator to avoid forming emulsions. Selected detergents should have minimal impact.

To minimize vehicle wash water, vehicles can be taken offsite and washed at a commercial vehicle washing facility. This will prevent the detergents from mixing with oily wastewaters and forming emulsions. PBSTs can also discharge wash water into municipal sewers to avoid mixing with other oily wastewaters. If vehicles are washed onsite, the amount of detergent used should be minimized and vehicle wash water should be segregated from other oily wastewaters.

Most vehicle maintenance wastes are comprised of vehicle fluids (e.g., brake fluid and antifreeze), which contain additives that stabilize emulsions. Facilities should haul these wastes offsite for recovery or disposal and not discharge them to the wastewater treatment system. Collection drums should be located in vehicle maintenance areas for each type of fluid.

Cryogenic vapor recovery systems chill the air that is displaced when filling tanks to remove hydrocarbon vapors. This method also condenses the humidity in the air, which becomes saturated with hydrocarbons. Because this wastewater contains high concentrations of hydrocarbons, the condensates are discharged to product tanks or slop oil tanks to recover product; therefore, this source is not typically managed as a wastewater stream. If there is a large amount of vapor recovery water, then there likely is an air leak into the aspiration system, which must be fixed to prevent explosions.

Haulback material water bottoms are generated by water entering service station tanks through leaks. To encourage service stations to fix such leaks and minimize the amount of haulback material water bottoms, PBSTs can charge service stations for the cost of hauling and

treating haulback materials. If the water originates from the product delivered from the PBST, then the PBST should minimize the entrainment of water as discussed previously.

The purpose of hydrostatic testing is to detect leaks in vessels and pipelines. This process requires large amount of water at high flow rates. To minimize the contamination of this water, PBSTs should clean the vessel or pipeline being tested thoroughly before the hydrotest.

Steam systems (or boilers) are used to heat heavy products to keep them fluid. The steam generated for heating becomes contaminated by corrosion inhibitors that are added to the boiler. To minimize wastewater generation, PBSTs should collect condensate from steam traps, return it to the boiler, and fix any leaks. In addition, internal steam-heating coils used in heavy products tanks may corrode, which can lead to leaks. To minimize this corrosion, PBSTs can use external heating coils on insulated tanks.

Implementing the following methods can minimize laboratory wastewater flow and contamination: using a vacuum pump or recycle water aspirator; disposing separately or reprocessing spent solvents and test samples; not using regulated solvents; placing solids and wastewater contaminated with regulated pollutants into collection drums for disposal; and washing laboratory glassware in a water-saving dishwasher, minimizing the use of detergents in cleaning.

Tanks accumulate sludge, which needs to be periodically removed by cleaning. During cleaning, none of the oily sludge should come in contact with the ground around the tank. In addition, having a contractor clean the tank and dispose the wastes generated off site can minimize tank cleaning wastewaters. Dry-cleaning methods can also be used to minimize the use of detergents. This wastewater should not come in contact with rainwater or oily wastewater.

7.12.6.4 Conclusions

EPA's primary source of wastewater discharge information for PBSTs is TRI and PCS. These sources contain discharge information for only a small portion of this industry, however. Less than 1 percent of the number of PBSTs (as determined from the 1997 Census) are in the PCS system, while only 5.5 percent reported to TRI in 2000.

Based on the information in TRI and PCS, pollutant discharges from PBSTs are small in comparison to those of other industrial categories, including refineries. Using information reported to TRI, EPA estimates that PBSTs discharge 8,010 TWPE to waters of the U.S. A few facilities contribute the overwhelming majority of this total TWPE. TRI information also indicates that the vast majority of these TWPEs are associated with stormwater discharges. Of the few facilities contributing to the overall TWPE, one (contributing 3,290 TWPEs) ceased operations in 2000. Discharges from a second facility (contributing more than 2,600 TWPE), are from a now-closed refinery that also performed PBST operations and are attributed to groundwater remediation activities only. Similarly, two facilities contribute the large majority of the 5,389 TWPE reported to PCS. Information from the PCS reporting

facilities that also report to TRI indicates that stormwater discharges are a significant source of the toxic pollutants discharged.

Information collected from permit and control authorities, site visits, and comment responses supports the conclusions reached from the TRI and PCS data. With few exceptions, discharges from PBSTs appear to be primarily stormwater with low concentrations of toxic pollutants. In addition, these stormwater discharges are subject to general or individual stormwater permits. Moreover, commenters and control authorities widely reported that tank bottoms water, the source of the most toxic waters produced at PBSTs are, by and large, transferred off site for treatment.

Therefore, based on this review, EPA has concluded that most PBSTs do not discharge toxic pollutants to waters of the United States. Of those that discharge, most discharge only stormwater which is subject to general or individual stormwater permitting requirements. For the few PBSTs that EPA identified as discharging toxic pollutants, EPA concludes it is reasonable to provide individual facility permit support, rather than an effluent guidelines rulemaking.

While EPA is deferring the development of effluent guidelines for PBSTs as a new subcategory under 40 CFR Part 419, it will continue to examine this industrial activity in future review cycles.

7.12.7 PBST References

1. Siddiqui, M.A., U.S. EPA. Memorandum to the Effluent Guidelines Planning Docket. *Discharge Status of PBST Facilities, as Enumerated by TRI and PCS Databases*. March 10, 2004.
2. Siddiqui, M.A., U.S. EPA. Telephone conversation regarding PBSTs with George Papadopoulos, U.S. EPA Region 1. April 29, 2004.
3. Siddiqui, M.A., U.S. EPA. Memorandum to the Effluent Guidelines Planning Docket. *Summary of Discussions with Permit Writers About PBST Facilities*. April 29, 2004.
4. Siddiqui, M.A., U.S. EPA. Memorandum to the Effluent Guidelines Planning Docket. *Meeting with PBST Stakeholders*. August 8, 2004.
5. Siddiqui, M.A., U.S. EPA. Telephone discussion regarding PBSTs with Jim Ball and Eric Beck, Rhode Island Department of the Environment, Providence, Rhode Island. April 29, 2004.
6. Pennsylvania State University. Thesis submitted in partial completion of Master of Science degree requirements by Julia DeNardo.

SECTION 8 NUTRIENT ANALYSIS

8.1 Introduction

Nutrients entering surface waters can cause many problems for aquatic ecosystem conditions. Excess nutrients can lead to eutrophication resulting in algal blooms, depleted oxygen levels, fish kills, and reduced biodiversity. In its annual review of effluent guidelines under Section 304(b) of the Clean Water Act, EPA examined the potential water quality impacts of nutrient discharges from facilities in the two industries for which EPA performed detailed studies (petroleum refining and OCPSF) to surface waters (4). This analysis is described in the following sections.

8.2 Reference Conditions

EPA's recommended Section 304(a) ecoregional water quality criteria for nutrients were developed with the aim of reducing and preventing cultural eutrophication (i.e., over enrichment of surface waters associated with human activities) on a national scale. The criteria were empirically derived to represent conditions of surface waters that are minimally impacted by human activities and protective of aquatic life and recreational uses. The nutrient criteria are numerical values for both causative (phosphorus and nitrogen) and response (chlorophyll a and turbidity) variables associated with the prevention and assessment of eutrophic conditions. They are not laws or regulations, but they represent EPA's recommendations as a starting point for states and tribes to use in establishing (with assistance from EPA) more refined nutrient criteria. While cultural eutrophication occurs in all parts of the country, specific levels of overenrichment leading to these problems vary from one region of the country to another due to geographical variations in watershed characteristics such as geographical variations in geology, vegetation, climate, and soil types. EPA has, therefore, developed its recommended nutrient criteria on an ecoregional basis.

Ecoregions are geographical areas based on similarities of natural geomorphological and biological characteristics and land use patterns. Ecoregions can be defined at multiple scales. For example, EPA has defined 14 nutrient ecoregions and 84 Level III subcoregions in the United States. Nutrient ecoregions are aggregations of Level III subcoregions where the landscape characteristics affecting nutrient levels are expected to be similar.

For this analysis, EPA determined reference conditions for total nitrogen and total phosphorous in rivers and streams for the 14 aggregate nutrient ecoregions. The reference conditions represent the least impacted conditions for a given ecoregion. The reference conditions were statistically determined by EPA following analyses of EPA's STORage and RETrieval (STORET) legacy data, USGS National Stream Quality Accounting Network (NASQAN) data, USGS National Water-Quality Assessment (NAWQA) data, and other relevant nutrient data from EPA regions, states, and universities. EPA used readily available data collected between January 1990 and December 1999. For each stream for which data existed within an ecoregion, EPA calculated the median nutrient concentrations in that stream for each

season of the year. Then, EPA took those median concentrations for each stream and calculated the 25th and 50th percentiles for the entire ecoregion during each of the four seasons. More information on the calculation of the reference conditions can be found in EPA's published 14 ecoregional documents for rivers and streams available at <http://www.epa.gov/waterscience/criteria/nutrient/ecoregions/rivers/index.html> (3). The aggregate reference conditions for each ecoregion were then calculated as the median value of the 25th percentiles and the 50th percentiles of the four seasons. The reference conditions representing the 25th and 50th percentiles were used in the stream dilution modeling as described in Section 8.4.

8.3 Decay Coefficients

Several processes, such as denitrification, uptake by aquatic biota, and sedimentation, occur naturally in streams and rivers to reduce the available levels of nitrogen and phosphorus. Research indicates that the total effect of these processes can be modeled using a first-order decay reaction. As discussed in an analysis of the effects of nutrient export between subwatersheds that accounts for nutrient decay by Wickham, et al (8), the amount of nitrogen and phosphorus delivered to a point downstream is an exponential function of travel time and a decay coefficient. Smith et al (2) developed decay coefficient values for nitrogen and phosphorus to be used in the Spatially Referenced Regressions on Watershed Attributes (SPARROW) model. The values were developed using data from over 380 USGS NASQAN stations. The decay coefficients were developed for use with three stream flowrate categories: <1,000 ft³/s, 1,000 - 10,000 ft³/s, and >10,000 ft³/s and are shown in Table 8-1. These values were also used in the development of the environmental assessment for Concentrated Animal Feeding Operations (see *Estimation of National Economic Benefits Using the National Water Pollution Control Assessment Model to Evaluate Regulatory Options for Concentrated Animal Feeding Operations (CAFOs, EPA-821-R-03-009)* December, 2002). For this analysis, 21 of the 68 modeled petroleum refining facilities and 70 of the 190 modeled OPCSF facilities were located on streams with a mean flow rate of greater than 10,000 ft³/s.

These decay coefficients (Table 8-1) were used in the stream dilution modeling.

Table 8-1. Decay Coefficients for Nitrogen and Phosphorus, Segregated by Stream Flowrate

Flowrate (ft ³ /s)	Decay Coefficients (d ⁻¹)*	
	Nitrogen	Phosphorus
< 1,000	0.3842	0.2680
1,000 - 10,000	0.1227	0.0956
>10,000	0.0408	0.0156

* Values were taken from the Final Model Bootstrap Coefficient column reported in Tables 1 and 2 from Smith et al (1997). The report did not develop a phosphorus decay coefficient for flowrates >10,000 ft³/s, so the Final Model Lower 90 percent Confidence Interval for flowrates between 1,000 and 10,000 ft³/s is being applied. This application is reasonable as the faster the flow rate, the longer it would take for the decay process to occur. Therefore, it is assumed that the lower 90 percent confidence is representative of the higher flow rates (i.e., those close to 10,000 ft³/s).

8.4 Methodology for Developing Total Nitrogen and Total Phosphorous Loads

This section describes the methodology that was applied to calculate total nitrogen and phosphorus loads for OCPSF facilities and petroleum refineries.

8.4.1 Total Nitrogen Load

The PCS database contains approximately 50 different parameters that may be reported for nitrogen compounds, and the TRI database includes discharge data for three nitrogen compounds. Table 8-2 presents the nitrogen compounds that are reported to TRI and PCS by OCPSF and petroleum refining facilities. The following assumptions were made regarding the parameters in Table 8-2:

- Total Nitrogen is the sum of organic nitrogen, ammonia, nitrite, and nitrate;
- Total Inorganic Nitrogen is the sum of ammonia, nitrite, and nitrate;
- Total Kjeldahl Nitrogen (TKN) is the sum of organic nitrogen and ammonia; and
- Unionized ammonia is a subset of total ammonia.

Table 8-2. Nitrogen Compounds Reported to TRI and PCS by OCPSF and Petroleum Refining Facilities

PRAM Code or CAS Number	Compound
<i>In PCS Database:</i>	
00600	Nitrogen, Total (As N)
00605	Nitrogen, Organic Total (As N)
00610	Nitrogen, Ammonia Total (As N)
00615	Nitrogen, Nitrite Total (As N)
00619	Ammonia, Unionized
00620	Nitrogen, Nitrate Total (As N)
00625	Nitrogen, Kjeldahl Total (As N)
00630	Nitrite plus Nitrate Total 1 DET (As N)
00640	Nitrogen, Inorganic Total
34726	Nitrogen, Ammonia, Total (As NH ₃)
61574	Ammonia (As N) + Unionized Ammonia
<i>In TRI Database:</i>	
7632000	Sodium Nitrite
7664417	Ammonia
N511	Nitrate Compounds

Loads of compounds that are not reported as nitrogen, such as sodium nitrite, nitrate compounds, or ammonia, were converted to pounds of nitrogen using the following equation:

$$\text{Lbs Nitrogen} = \text{Lbs Compound} * (\text{Molecular Weight (MW) Nitrogen} / \text{MW Compound})$$

The data obtained from the PCS and TRI databases required manual modification to avoid overestimating the nitrogen loads. For some facilities, a single NPDES number matched multiple TRI Ids, and vice versa. In the case where a single NPDES number matched multiple TRI Ids, the PCS loads were divided among the TRI Ids. In the case where a single TRI Id matched multiple NPDES numbers, the TRI releases were divided among the NPDES numbers.

The following hierarchy was applied for calculating the total nitrogen load:

1. Use PCS PRAM 00600, if reported, to represent total Nitrogen.

2. If PCS PRAM 00600 is not reported, use the sum of TKN, Nitrite, and Nitrate.
3. If neither of the first two rules apply, use the sum of Organic Nitrogen, Ammonia, Nitrite, and Nitrate.
4. Where applicable, use TRI data to fill in for missing PCS parameters in the total nitrogen calculation.
5. If no nitrogen compounds are reported to PCS, use the sum of Ammonia, Sodium nitrite, and Nitrate compounds reported to TRI.

The final loads table presents the TRI ID, NPDES number, total nitrogen load, REACH number, and the latitude/longitude coordinates for each facility.

8.4.2 Total Phosphorus Load

The total phosphorus load was calculated using PCS data. The TRI database only includes discharge data for elemental phosphorus, which is not reported by any of the facilities in OCSPF or Petroleum Refining. Table 8-3 presents the phosphorous parameters that are reported to PCS by OCPSF and petroleum refining facilities.

Table 8-3. Phosphorus Parameters Reported to PCS by OCPSF and Petroleum Refining Facilities

PRAM Code	Phosphorus Parameter
00665	Phosphorus, Total (As P)
00662	Phosphorus, Total Recoverable
00650	Phosphate, Total (As PO4)
70507	Phosphorus, in Total Orthophosphate
71888	Phosphorus, Total Soluble (As PO4)

All discharges that were reported as phosphate were converted to pounds of phosphorus using the following equation:

$$\text{Lbs Phosphorus} = \text{Lbs Phosphate} * (\text{MW Phosphorus} / \text{MW Phosphate}).$$

The data obtained from the PCS database required manual modification to avoid overestimating the phosphorus loads. For some facilities, a single NPDES number matched multiple TRI Ids. For these facilities, the PCS loads were divided among the TRI Ids.

The following hierarchy was applied for selecting PCS parameters to represent the total phosphorus load:

1. Use PCS PRAM 00665, if reported, to represent total Phosphorus.
2. If PCS PRAM 00665 is not reported, use the Total Recoverable Phosphorus load.
3. If neither of the first two rules apply, use the Phosphate load.
4. If no other Phosphorus parameters are reported, use the Soluble Phosphate load.

The final loads table presents the TRI ID, NPDES number, total phosphorus load, REACH number, and the latitude/longitude coordinates for each facility.

8.5 Stream Dilution Modeling

EPA incorporated exponential decay loss for total nitrogen and total phosphorus into a simplified stream dilution model by projecting the concentration, under 7Q10 low flow (lowest consecutive seven-day average flow during any 10-year period) and mean receiving stream flow conditions, at a distance (1,000 m) downstream from 68 petroleum refining facilities discharging to 57 receiving streams and 190 OCPSF facilities discharging to 153 receiving streams (Equations 1 and 2). Facilities discharging to estuaries/bays were not evaluated.

$$C_{is} = \frac{L/OD}{FF+SF} \times CF \quad \text{Eq. 1}$$

$$C_{ds} = C_{is} e^{-kt} \quad \text{Eq. 2}$$

where

C_{is}	=	instream pollutant concentration (milligrams per liter [mg/L])
L	=	facility pollutant loading (pounds per year [lbs/yr])
OD	=	facility operating days (days per year [days/yr])
FF	=	facility effluent flow (million gallons per day [MGD])
SF	=	receiving stream flow (million gallons per day [MGD])
CF	=	conversion factors for units
C_{ds}	=	in-stream pollutant concentration 1,000 meters downstream (milligrams per liter [mg/L])
k	=	decay coefficient (days ⁻¹)
t	=	time to travel 1,000 meters (days)

Receiving stream flow data were obtained from the W.E. Gates study data which is contained in EPA's GAGE File (5). Facility effluent flow data were obtained from EPA's Permit Compliance System (PCS) (1) or Industrial Facilities Discharge (IFD) File (6). All facilities were assumed to be in operation 365 days per year. The 1,000 m distance represents the maximum distance that the stream flow rates and velocities for a particular reach were considered applicable. EPA then estimated the travel time required in the exponential decay equation by dividing the travel

distance (1,000 m) by the reach velocity (available from EPA's GAGE File). The estimated instream concentrations were then compared to the appropriate total nitrogen and total phosphorous aggregate reference condition values to estimate the effects on the environment at current discharge levels. Each of the modeled facilities was assigned to one of the 14 nutrient ecoregions based on locational information and the use of ArcView GIS software. EPA identified the locations of facilities on receiving streams using the U.S. Geological Survey (USGS) cataloging and stream segment (reach) numbers contained in EPA's REACH File (RF1) (7). Estimated instream concentrations were compared directly to the 25th and 50th percentile aggregate reference condition values to determine impacts. To determine a water quality excursion, EPA divided the projected instream concentration by the reference condition value. A number greater than 1.0 indicated an excursion.

8.6 Results

The results of this analysis indicate the potential water quality impacts of nutrient discharges from petroleum refining and OCPSF facilities. Tables 8-4 and 8-5 present a summary of the results. This analysis is not designed to predict actual instream concentrations, but instead evaluate, at a screening level, the relative impacts of facilities under current conditions.

8.6.1 Petroleum Refining

Under current discharge levels, in the absence of all other sources of nitrogen and phosphorus, and assuming 7Q10 low flow stream conditions, nitrogen concentrations in 12 receiving streams (out of 57 modeled) would exceed the upper 25th percentile reference condition of 'least impacted' streams due to petroleum refining discharges. (Table 8-4. As noted above, EPA's recommends that states and tribes use the upper 25th percentile reference condition of 'least impacted' streams as a starting point for establishing more refined nutrient criteria.) Petroleum refining discharges would result in 11 receiving streams having estimated instream nitrogen concentrations higher than the 50th (i.e., median) percentile reference conditions. Under mean flow conditions, one receiving stream is projected to exceed both the 25th percentile reference condition of 'least impacted' streams and 50th (i.e., median) percentile reference conditions (Table 8- 4). When modeled similarly, phosphorus discharges from petroleum refining plants do not result in any streams having concentrations higher than the upper 25th percentile reference condition of 'least impacted' streams. (Table 8-4). EPA notes that, by definition, many receiving streams exceed the 25th and 50th percentile reference conditions, even in the absence of petroleum refining facility discharges, but this screening-level analysis demonstrates the potential for petroleum refining nutrient discharges to affect water quality.

Table 8-4. Summary of Screening-level Nutrient Analysis for Petroleum Refining Direct Discharge Facilities

	Total Nitrogen		Total Phosphorus	
	7Q10 Flow	Mean Flow	7Q10 Flow	Mean Flow
25th Percentile				
Current				
Stream (No.)	12	1	0	0
Magnitude	1.3 - 9.4	7.0	NA	NA
50th Percentile				
Current				
Stream (No.)	11	1	0	0
Magnitude	1.2 - 5.4	4.8	NA	NA

Note: Magnitude represents the range in the extent of the excursions (i.e., ratio of instream concentrations to criteria >1.0)
 25th and 50th percentiles aggregate seasons and nutrient ecoregion reference conditions
 Number of streams evaluated = 57 and number of facilities = 68
 Assumes operating days = 365
 May 2004, Loadings File

8.6.2 OCPSF

Under current discharge levels, in the absence of all other sources of nitrogen and phosphorus, and assuming 7Q10 low flow stream conditions, nitrogen concentrations in 19 receiving streams (out of 153 modeled) would exceed the upper 25th percentile reference condition of ‘least impacted’ streams due to OCPSF discharges. (Table 8-5. As noted above, EPA’s recommends that states and tribes use the upper 25th percentile reference condition of ‘least impacted’ streams as a starting point for establishing more refined nutrient criteria.) OCPSF discharges would result in 14 receiving streams having estimated instream nitrogen concentrations higher than the 50th (i.e., median) percentile reference conditions. Under mean flow conditions, four receiving streams are projected to exceed both the 25th and 50th percentile reference conditions (Table 8-5). When modeled similarly, phosphorus discharges from OCPSF plants do not result in any streams having concentrations higher than the upper 25th percentile reference condition of ‘least impacted’ streams. (Table 8-5). EPA notes that, by definition, many streams exceed the 25th and 50th percentile reference conditions, even in the absence of OCPSF facility discharges, but this screening-level analysis demonstrates the potential for OCPSF nutrient discharges to affect water quality.

Table 8-5. Summary of Screening-level Nutrient Analysis for OCPSF Direct Discharge Facilities

	Total Nitrogen		Total Phosphorus	
	7Q10 Flow	Mean Flow	7Q10 Flow	Mean Flow
25th Percentile				
Current				
Stream (No.)	19	4	0	0
Magnitude	1.0 - 355	1.9 - 75	NA	NA
50th Percentile				
Current				
Stream (No.)	14	4	0	0
Magnitude	1.0 - 252	1.2 - 53	NA	NA

Note: Magnitude represents the range in the extent of the excursions (i.e., ratio of instream concentrations to criteria >1.0)

25th and 50th percentiles aggregate seasons and nutrient ecoregion reference conditions

Number of streams evaluated = 153 and number of facilities = 190

Assumes operating days = 365

May 2004, Loadings File

8.7 **References**

1. Permit Compliance System (PCS). Estimated Using the Effluent Data Statistics System (EDSS). Washington, D.C. April 1996.
2. Smith R.A., G.E. Schwartz, and R.B. Alexander. "Regional Interpretation of Water-Quality Monitoring Data." *Water Resources Research* 33:2781-2798. 1997.
3. U.S. EPA. *Ecoregional Nutrient Criteria Documents for Rivers and Streams*. Available online at: <http://www.epa.gov/waterscience/criteria/nutrient/ecoregions/rivers/index.html>. Washington, D.C. Accessed October 2003.
4. U.S. EPA, Office of Water, Engineering and Analysis Division. *Petroleum Refining and OCPSF Loadings File*. Washington, D.C. 2004.
5. U.S. EPA, Office of Wetlands, Oceans, and Watersheds. *GAGE File*. Washington, D.C. Downloaded February 2000.
6. U.S. EPA, Office of Wetlands, Oceans and Watersheds. *Industrial Facilities Discharge (IFD) File*. Washington, D.C. Downloaded November 1998.

7. U.S. EPA, Office of Wetlands, Oceans, and Watersheds. *REACH File* (RF1). Washington, D.C. Downloaded February 2000.
8. Wickham J.D., T.G. Wade, K.H. Riitters, R.V. O'Neill, J.H. Smith, E.R. Smith, K.B. Jones, and A.C. Neale. "Upstream-to-Downstream Changes in Nutrient Export Risk." *Landscape Ecology*, 18:195-208. 2003.

SECTION 9 INDUSTRIES IDENTIFIED AS NEW BY COMMENTERS

This section discusses EPA's identification of new industrial categories for effluent guidelines rulemaking. Section 304(m)(1)(B) of the Clean Water Act requires EPA to identify categories of sources discharging toxic and nonconventional pollutants in nontrivial amounts, for which effluent guidelines under Section 304(b)(2) and new source performance standards under Section 306 have not yet been published. EPA identified two industrial activities that meet the criteria specified in Section 304(m)(1)(B): airport deicing operations and drinking water supply and treatment facilities. EPA is identifying both of these activities in the 2004 Final Effluent Guidelines Program Plan. This section provides information on the basis for EPA's identification of these two new categories.

9.1 Airport Deicing Operations

EPA did not identify the airport deicing discharges (SIC code 4581) as a potential candidate for effluent guidelines development in the Preliminary Plan. At that time, EPA noted that it had inadequate data to determine if airport deicing discharges were nontrivial. Public comments on the Preliminary Plan suggested that EPA consider developing effluent guidelines for this industrial sector due to the potential for facilities in this industrial sector to discharge nontrivial amounts of nonconventional and toxic pollutants. In particular, commenters stated that airport deicing fluid (ADF) is not properly recaptured and re-used or properly treated before discharge. Commenters noted that these discharges can cause significant harm to natural resources such as fish kills, algae blooms, and contamination of surface or ground waters.

Following the Preliminary Plan, EPA collected additional information and revisited the information in its docket. EPA's primary source of wastewater discharge information for this industry is its *Preliminary Data Summary: Airport Deicing Operations*, which was published in August 2000 (EPA-821-R-00-016). This study focused on approximately 200 U.S. airports with potentially significant deicing/anti-icing operations. The major source of pollutant discharges from deicing operations is deicing agent contaminated stormwater which typically contains water, glycols, and additives. However, the study showed that there was great disparity among airports in terms of permit requirements. Some airports, generally those with stringent stormwater discharge permits, had made great strides in terms of wastewater collection, containment, pollution prevention and/or recycling/treatment programs. Other airports, however, did much less to manage their stormwater.

At the time of the study, annual discharge estimates to surface waters were 21 million gallons of ADF. EPA also estimated that full implementation of stormwater permits would reduce these discharges to 17 million gallons annually. Finally, the study also estimated possible reductions in ADF discharges if effluent limitations guidelines and standards were implemented for discharges resulting from airport deicing operations. Using results from technologies and pollution prevention practices employed at some of the better performing airports, EPA estimated annual surface water discharges could be reduced to 4 million gallons.

A review of current and proposed discharge permits for over 20 airports indicates that while some airports have more stringent permits and have reduced their ADF discharges since EPA's earlier study was conducted, there is still significant disparity among discharge requirements. For example, some are only required to implement BMPs and sample on a limited basis for a few conventional pollutants while others have instituted significant BMPs, collection, and/or treatment to comply with a 2 mg/L ADF discharge limitation. Based on the information in its study and a review of this permit information, EPA concludes that it is appropriate to identify discharges from airport deicing operations in this Final Plan, and to take final action on effluent guidelines within three years.

For information about EPA's economic analysis and small business considerations of this sector, see the August 16, 2004 Memorandum entitled *Airport Industrial Discharges—Industry Profile* and the August 6, 2004 memorandum entitled *Airport Industrial Discharges: Number of Small Entities* (located in the docket).

9.2 Drinking Water Supply & Treatment

EPA did not identify the drinking water supply and treatment industrial sector (SIC code 4941) as a potential candidate for effluent guidelines development in the Preliminary Plan. At that time, EPA concluded that almost all of the hazard posed by this industrial sector was due to a few facilities. In particular, EPA's analysis showed that a single facility was contributing over 97% of the TWPE discharges for the entire industrial sector. Public comments on the Preliminary Plan suggested that EPA consider developing effluent guidelines for this industrial sector due to the potential of facilities in this industrial sector to discharge nontrivial amounts of nonconventional and toxic pollutants (e.g., metals and salts). In particular, commenters stated that many drinking water facilities have the potential to discharge significant quantities of conventional and toxic pollutants. These commenters noted that the source of these pollutants can include drinking water treatment sludges and reverse osmosis reject wastewaters. Consequently, EPA attempted to collect additional information and re-evaluated the information in the docket supporting the 2004 Final Plan.

Based on information in the 1997 Economic Census, EPA estimates there are 3,700 drinking water treatment and supply facilities in the United States. For information about EPA's economic analysis and small business considerations of this sector, see the August 11, 2004 Memorandum entitled *Drinking Water Facilities Profile* and the August 4, 2004 memorandum entitled *Estimated Number of Small Entities Owning Drinking Water Facilities* (located in the docket).

EPA's primary source of wastewater data for this industry is EPA's Permit Compliance System (PCS). This database contains information required by the NPDES Permit Program for major dischargers across the country, including discharge flows and pollutant

concentrations¹. EPA was therefore able to analyze this information for the 16 drinking water supply and treatment facilities with major permits for the year 2000. However, EPA does not require states to include such data for other dischargers (e.g., minor and indirect dischargers) in PCS, so little information is available about industries dominated by minor and indirect dischargers. PCS lists approximately 900 drinking water supply and treatment facilities as having minor permits for the year 2000, but does not include data on discharge flows or pollutant concentrations. Consequently, EPA was unable to quantify discharges from these minor and indirect discharging facilities.

The TWPE for the sixteen facilities ranged from significant to very low. Total residual chlorine and metals (e.g., manganese and aluminum) represent most of the TWPE discharges from these sixteen facilities. The TWPE estimate for these sixteen facilities is largely related to the wastewater discharges from three facilities. For the remaining 13 facilities, PCS data indicate that pollutants are being discharged at or near the detection levels raising concerns about further treatability of these pollutants using end-of-pipe treatment. More recent PCS information suggests the TWPE discharges at some of these sixteen facilities have decreased. In particular, the top two hazard discharging facilities for the year 2000 have added technology to properly de-water their wastewater treatment sludges and are likely to reduce their wastewater discharges by 85 percent or more. Further, one of the two facilities no longer discharges any wastewater associated with drinking water operations. Analysis of PCS data from 2003 indicates that the sixteen facilities with quantitative data are currently discharging approximately 20,500 TWPEs.

While this PCS data suggests that some drinking water supply and treatment facilities with direct discharging permits are not discharging pollutants in significant concentrations, it also supports commenters' statements that other drinking water treatment and supply facilities may discharge nontrivial amounts of toxic and nonconventional pollutants, which EPA considers in deciding whether EPA should develop effluent guidelines for an industry that is not yet regulated by effluent guidelines. Therefore, EPA has identified the drinking water supply and treatment industry as a possible new category in the 2004 Final Plan and will take final action on potential effluent guidelines for this category within three years. See CWA Section 304(m)(1)(C).

¹A major discharger is any NPDES facility or activity classified as such by the Regional Administrator, or, in the case of approved State Programs, the Regional Administrator in conjunction with the State Director. Major industrial facilities are determined based on specific ratings criteria developed by EPA and approved State Programs.